



Speroff's  
**Clinical  
Gynecologic  
Endocrinology  
and Infertility**

---

Ninth Edition

---

**HUGH S. TAYLOR  
LUBNA PAL  
EMRE SELI**

Speroff's  
CLINICAL GYNECOLOGIC  
ENDOCRINOLOGY AND INFERTILITY

---

# Speroff's CLINICAL GYNECOLOGIC ENDOCRINOLOGY AND INFERTILITY

---

Ninth Edition

**Hugh S. Taylor, MD**

**Lubna Pal, MBBS, MS**

**Emre Seli, MD**

Department of Obstetrics, Gynecology and  
Reproductive Sciences  
Yale School of Medicine  
New Haven, Connecticut



Wolters Kluwer

Philadelphia • Baltimore • New York • London  
Buenos Aires • Hong Kong • Sydney • Tokyo

Acquisitions Editor: Chris Teja  
Development Editor: Ashley Fischer  
Editorial Coordinator: John Larkin  
Production Project Manager: Kim Cox  
Design Coordinator: Holly McLaughlin  
Manufacturing Coordinator: Beth Welsh  
Prepress Vendor: SPi Global

Ninth edition

**Copyright © 2020 Wolters Kluwer**

©2011 by LIPPINCOTT WILLIAMS & WILKINS, a WOLTERS KLUWER business, © 2005 by Lippincott Williams & Wilkins All rights reserved. This book is protected by copyright. No part of this book may be reproduced or transmitted in any form or by any means, including as photocopies or scanned-in or other electronic copies, or utilized by any information storage and retrieval system without written permission from the copyright owner, except for brief quotations embodied in critical articles and reviews. Materials appearing in this book prepared by individuals as part of their official duties as U.S. government employees are not covered by the above-mentioned copyright. To request permission, please contact Wolters Kluwer at Two Commerce Square, 2001 Market Street, Philadelphia, PA 19103, via email at [permissions@lww.com](mailto:permissions@lww.com), or via our website at [shop.lww.com](http://shop.lww.com) (products and services).

Printed in China

---

**Cataloging-in-Publication Data available on request from the Publisher**

**ISBN: 978-1-4511-8976-6**

---

This work is provided “as is,” and the publisher disclaims any and all warranties, express or implied, including any warranties as to accuracy, comprehensiveness, or currency of the content of this work.

This work is no substitute for individual patient assessment based upon healthcare professionals’ examination of each patient and consideration of, among other things, age, weight, gender, current or prior medical conditions, medication history, laboratory data and other factors unique to the patient. The publisher does not provide medical advice or guidance and this work is merely a reference tool. Healthcare professionals, and not the publisher, are solely responsible for the use of this work including all medical judgments and for any resulting diagnosis and treatments.

Given continuous, rapid advances in medical science and health information, independent professional verification of medical diagnoses, indications, appropriate pharmaceutical selections and dosages, and treatment options should be made and healthcare professionals should consult a variety of sources. When prescribing medication, healthcare professionals are advised to consult the product information sheet (the manufacturer’s package insert) accompanying each drug to verify, among other things, conditions of use, warnings and side effects and identify any changes in dosage schedule or contraindications, particularly if the medication to be administered is new, infrequently used or has a narrow therapeutic range. To the maximum extent permitted under applicable law, no responsibility is assumed by the publisher for any injury and/or damage to persons or property, as a matter of products liability, negligence law or otherwise, or from any reference to or use by any person of this work.

[shop.lww.com](http://shop.lww.com)

---

# Associate Contributors

## **Baris Ata, MD, MSc**

Visiting Professor

Department of Obstetrics, Gynecology and Reproductive Sciences

Yale School of Medicine

New Haven, Connecticut

## **Stephen Collins, MD, PhD**

Assistant Professor

Department of Obstetrics, Gynecology and Reproductive Sciences

Yale School of Medicine

New Haven, Connecticut

## **Valerie Flores, MD**

Assistant Professor

Department of Obstetrics, Gynecology and Reproductive Sciences

Yale School of Medicine

New Haven, Connecticut

## **Olga Grechukhina, MD**

Clinical Instructor

Department of Obstetrics, Gynecology and Reproductive Sciences

Yale School of Medicine

New Haven, Connecticut

## **Pinar Kodaman, MD, PhD**

Assistant Professor

Department of Obstetrics, Gynecology and Reproductive Sciences

Yale School of Medicine

New Haven, Connecticut

## **Alexander M. Kotlyar, MD**

Clinical Instructor

Department of Reproductive Endocrinology and Infertility  
Yale School of Medicine  
New Haven, Connecticut

**Amir Mor, MD, PhD**

Clinical Instructor  
Department of Reproductive Endocrinology and Infertility  
Yale School of Medicine  
New Haven, Connecticut

**Samantha Simpson, MD**

Clinical Instructor  
Department of Obstetrics, Gynecology and Reproductive Sciences  
Yale School of Medicine  
New Haven, Connecticut

**Reshef Tal, MD, PhD**

Assistant Professor  
Department of Obstetrics, Gynecology and Reproductive Sciences  
Yale School of Medicine  
New Haven, Connecticut

**Saioa Torrealday, MD**

Assistant Professor  
Uniformed Services University of the Health Sciences  
Walter Reed National Military Medical Center  
Bethesda, Maryland

---

# Foreword

I was extremely pleased when I learned that the ninth edition of this textbook would once again be coming from Yale. And I reacted with a strong sense of honor and gratitude when I saw my name on the cover. It was 47 years ago at Yale when Bob Glass and Nathan Kase invited me to join them in writing a textbook on infertility and reproductive endocrinology. That manuscript, typed on a Royal portable typewriter, appeared a year later, 273 pages long for a price of \$17. Each edition grew in weight, size, and price, and so did the challenge and amount of work required.

Being associated with this book has been one of the best and most rewarding experiences in my career. It opened doors for me, not only in our own country but all over the world. Because of this book, I and my family made many new friends and visited places that otherwise would have existed only in my dreams.

It is good to see Yale Blue once again on the cover. It is also with great emotional warmth that I view the Macedonian Star on the cover, a feature that was introduced with the sixth edition of the book. The Macedonian Star is a symbol that dates from the days of Philip of Macedon and Alexander the Great. How I wish that my grandparents and father, who came from Macedonia to America in 1921, could see the cover of the ninth edition.

In the Preface to the last edition, I told a story that bears repeating. In 1999, I was standing on a street corner in New York City waiting for the change in the light. For unknown reasons, I was struck in that moment with a thought that was so strong, I was frozen in my tracks. I stood there thinking, while everyone else crossed the street, that what was written in this book could have an impact on individual patients. The force behind this thought was a sudden appreciation for the enormity of the responsibility that comes with writing a clinical book to transmit accurately the knowledge that is based on all available evidence. This important task has grown progressively larger in its scope with the explosion of scientific and medical reports in each passing decade. And yet, as always, there are physiologic events and pathologic disturbances that are not currently understood. For this reason, authors writing a clinical book must still draw upon their own experiences and offer judgments regarding the understanding and care of patients.

I hope this book, dedicated to the care of patients, continues to be used by students, residents, and clinicians. If anyone appreciates how much work goes into clinical writing, I certainly do. And so, a heart-felt thank you to my Yale colleagues for their commitment and effort in bringing the ninth edition to publication.

**Leon Speroff, MD**  
Professor Emeritus of Obstetrics and Gynecology  
Oregon Health & Science University  
Portland, Oregon



---

# Preface

It is a tremendous honor for us to author Speroff's Gynecologic Endocrinology and Infertility. This text has been considered the classic in the field. It is the resource that most of us initially used to learn reproductive physiology and endocrinology. How does one rewrite a text that is the classic in the field? Rather than be so presumptuous as to try and improve on Dr. Speroff's writing, we took the approach of updating a classic text by adding new information; we focused on changes and advances that have occurred in the field since prior editions. These include new chapters on transgender medicine and fertility preservation. We left as much as Dr. Speroff's original prose as possible. We are indebted to Dr. Speroff for entrusting us with his treatise.

This text originated in the Department of Obstetrics and Gynecology at the Yale School of Medicine. Drs. Speroff, Glass, and Kase were all faculty in the department at the time and all contributed. However, Dr. Speroff's passion for writing and education allowed him to persist through the multiple editions of the book, continually improving and expanding on the text. The book travelled with him to numerous academic institutions. Speroff's Gynecologic Endocrinology and Infertility now triumphantly returns to Yale, its place of birth, with a new set of authors on the Yale faculty. Discussion surrounding the transition occurred originally at a meeting of the Yale Obstetrics and Gynecologic Society in New Haven. At that meeting, we honored Dr. Speroff with our distinguished alumni award. When he suggested returning the book to its rightful home, we were eager to take on the challenge.

The book is indeed a group effort of all the authors and many other contributors. In addition to Dr. Speroff, the authors would like to thank Dr. Marc Fritz who led this text through several prior editions. His contributions clearly helped to keep the book current over the past several years. We also want to thank our publisher, Wolters Kluwer, for their persistence, dedication, and encouragement along the way. In particular, we thank Chris Teja and Ashley Fischer for their leadership and organizational skills without which this book would not be in print until well after its current publication date.

We hope that the readers of this book will gain as much from it as each of us previously has during our careers. Nothing will bring us more satisfaction than to inspire the next generation of women's health professionals.

**Hugh S. Taylor, MD**  
**Lubna Pal, MBBS, MS**  
**Emre Seli, MD**

Yale School of Medicine  
New Haven, Connecticut

---

# Contents

Associate Contributors

Foreword

Preface

## Section I: REPRODUCTIVE PHYSIOLOGY

- 1. Hormone Biosynthesis, Metabolism, and Mechanism of Action**  
How hormones are formed and metabolized, and how hormones work.
- 2. The Ovary—Embryology and Development**  
The ovary from conception to adult function; correlation of morphology with reproductive and steroidogenic function.
- 3. The Uterus, Endometrial Physiology, and Menstruation**  
Embryology, histology, and endocrinology of the uterus and menstruation. Anatomical abnormalities and leiomyomas.
- 4. Neuroendocrinology**  
How reproductive events are perceived, integrated, and acted upon by the central nervous system.
- 5. Regulation of the Menstrual Cycle**  
The cyclic changes of ovarian and pituitary hormones and growth factors, and what governs those changes.
- 6. Conception - Sperm and Egg Transport, Fertilization, Implantation and Early Embryogenesis**  
Physiologic events occurring on the days just before and after conception.

## **7. The Endocrinology of Pregnancy**

The steroid and protein hormones of pregnancy.

## **Section II: CLINICAL ENDOCRINOLOGY**

### **8. Normal and Abnormal Sexual Development**

Normal and abnormal sexual differentiation and the differential diagnosis of ambiguous genitalia.

### **9. Normal and Abnormal Growth and Pubertal Development**

The physiology of puberty and abnormalities that produce accelerated or retarded sexual maturation and growth problems in adolescents.

### **10. Amenorrhea**

Differential diagnosis of amenorrhea of all types utilizing procedures available to all clinicians. The problems of galactorrhea and pituitary adenomas, exercise and amenorrhea.

### **11. Chronic Anovulation and the Polycystic Ovary Syndrome**

How loss of ovulation can occur and the clinical expressions of anovulation. The polycystic ovary and hyperinsulinemia.

### **12. Hirsutism**

The biology of hair growth; the evaluation and management of hirsutism.

### **13. Reproduction and the Adrenal**

Relevance of normal adrenal function to reproductive physiology and endocrinology, and clinical and endocrine features of adrenal disorders

### **14. Menstruation-Related Disorders**

Medical problems linked to menstruation: the premenstrual syndrome, dysmenorrhea, menstrual headache, catamenial seizures,

premenstrual asthma, and catamenial pneumothorax.

**15. Abnormal Uterine Bleeding**

A physiologic basis for medical management with or without primary surgical intervention.

**16. The Breast**

The factors involved in physiologic lactation, and the differential diagnosis of galactorrhea. The endocrinology of breast cancer.

**17. Menopause Transition and Menopause Hormone Therapy**

Physiology of the menopause; long-term effects of estrogen on cognition, the cardiovascular system, and bone. A clinical guide for menopausal hormone therapy and patient management.

**18. Transgender Endocrinology**

Terminology, and overview of management considerations, options and approaches.

**19. Obesity**

The physiology of adipose tissue, and the problem of obesity.

**20. Reproduction and the Thyroid**

Normal and abnormal thyroid function, including a consideration of the thyroid gland in pregnancy.

**Section III: CONTRACEPTION**

**21. Family Planning, Sterilization, and Abortion**

The modern efficacy and use of contraception; the clinical methods and problems with sterilization and induced abortion.

**22. Hormonal Contraception**

A survey of the risks and benefits of hormonal (oral and nonoral) contraceptive options. Methods for patient management, including

the progestin-only minipill, options with improved compliance and emergency contraception.

**23. Long-Acting Methods of Contraception**

The advantages and disadvantages of specific long-acting contraceptive methods.

**24. Barrier Methods of Contraception and Withdrawal**

Important information for the use of the diaphragm, the cervical cap, the sponge, spermicides, and condoms. The underrated withdrawal method of contraception.

**Section IV: INFERTILITY**

**25. Female Infertility**

An approach to the problem of infertility. The proper diagnostic tests and their correct interpretation.

**26. Male Infertility**

Principles of male infertility, including analysis of semen, treatment, and therapeutic insemination.

**27. Induction of Ovulation**

Indications, strategies and options, risks, benefits, success rates, and complications for clomiphene, aromatase inhibitors, gonadotropins, dopamine agonists, GnRH.

**28. Assisted Reproductive Technologies**

An overview of the assisted reproduction technologies.

**29. Fertility Preservation**

Indications, strategies and options for fertility preservation.

**30. Recurrent Early Pregnancy Loss**

The evaluation and management of recurring spontaneous losses in

early pregnancy.

**31. Genetics**

Basic concepts of molecular biology and genetics, laboratory technologies, and clinical applications.

**32. Endometriosis**

Diagnosis and suitable treatment for the individual patient.

**33. Ectopic Pregnancy**

The diagnosis and treatment, both medical and surgical, of ectopic pregnancy.

Appendix

Selected laboratory values expressed in conventional units and the International System of Units (SI Units)

Index

# REPRODUCTIVE PHYSIOLOGY

---



**Chapter 1:** Hormone Biosynthesis, Metabolism, and Mechanism of Action



**Chapter 2:** The Ovary–Embryology and Development



**Chapter 3:** The Uterus, Endometrial Physiology, and Menstruation



**Chapter 4:** Neuroendocrinology



**Chapter 5:** Regulation of the Menstrual Cycle



**Chapter 6:** Conception - Sperm and Egg Transport, Fertilization, Implantation and Early Embryogenesis



**Chapter 7:** The Endocrinology of Pregnancy





---

# Hormone Biosynthesis, Metabolism, and Mechanism of Action

The classical definition of a hormone is a substance that is produced in a special tissue, from which it is released into the bloodstream and travels to distant responsive cells in which the hormone exerts its characteristic effects. What was once thought of as a simple voyage is now appreciated as an odyssey that becomes more complex as new facets of the journey are unraveled in research laboratories throughout the world. Indeed, even the notion that hormones are products only of special tissues has been challenged.

Complex hormones and hormone receptors have been discovered in primitive, unicellular organisms, suggesting that endocrine glands are a late development of evolution. Hormones must have appeared even before plants and animals diverged because there are many plant substances similar to hormones and hormone receptors. The widespread capability of cells to make hormones explains the puzzling discoveries of hormones in strange places, such as gastrointestinal hormones in the brain and reproductive hormones in intestinal secretions. Furthermore, because every cell contains the genes necessary for hormonal expression, it is not surprising that dedifferentiated cancer cells can uncover gene expression and, in inappropriate locations and at inappropriate times, make hormones.

Hormones, therefore, are substances that provide a means of communication and should now be viewed broadly as chemical regulatory and signaling agents. The classic endocrine hormones travel through the bloodstream to distant sites, but cellular communication is also necessary at local sites. Paracrine, autocrine, and intracrine depict a more immediate form of communication. As compared to the distant sites of action of endocrine signals, paracrine refers to intercellular communication involving the local diffusion of regulating substances from a cell to nearby (contiguous) cells. In further contrast, autocrine and intracrine refer to forms of intracellular communication; the former involves secreted substances that act on receptors on the surface of the same cell, while the latter utilizes unsecreted substances to communicate via receptors within the same cell.

Let us follow an estradiol molecule throughout its career and in so doing gain an overview of how hormones are formed, how hormones work, and how hormones are metabolized. Estradiol begins its life span with its synthesis in a cell specially suited

for this task. For this biosynthesis to take place, the proper enzyme capability must be present along with the proper precursors. In the adult human female, the principal sources of estradiol are the granulosa cells of the developing follicle and the corpus luteum. These cells possess the ability to turn on steroidogenesis in response to specific stimuli. The stimulating agents are the gonadotropins, follicle-stimulating hormone (FSH), and luteinizing hormone (LH). The initial step in the process that will give rise to estradiol is the transmission of the message from the stimulating agents to the steroid-producing mechanisms within the cells.

Messages that stimulate steroidogenesis must be transmitted through the cell membrane. This is necessary because gonadotropins, being large glycopeptides, do not ordinarily enter cells but must communicate with the cell by joining with specific receptors on the cell membrane. In so doing, they activate a sequence of communication. A considerable amount of investigation has been devoted to determining the methods by which this communication takes place. E. W. Sutherland, Jr., received the Nobel Prize in 1971 for proposing the concept of a second messenger.

Gonadotropin, the first messenger, activates an enzyme in the cell membrane called adenylate cyclase. This enzyme transmits the message by catalyzing the production of a second messenger within the cell, cyclic adenosine 3',5'-monophosphate (cyclic AMP). The message passes from gonadotropin to cyclic AMP, much like a baton in a relay race.

Cyclic AMP, the second messenger, initiates the process of steroidogenesis, leading to the synthesis and secretion of the hormone estradiol. This notion of message transmission has grown more and more complex with the appreciation of physiologic concepts, such as the heterogeneity of peptide hormones, the up- and down-regulation of cell membrane receptors, the regulation of adenylate cyclase activity, and the important roles for autocrine and paracrine regulating factors.

Secretion of estradiol into the bloodstream directly follows its synthesis. Once in the bloodstream, estradiol exists in two forms, bound and free. A majority of the hormone is bound to protein carriers, albumin, and sex steroid hormone-binding globulin. The biologic activity of a hormone is limited by binding in the blood, thereby avoiding extreme or sudden reactions. In addition, binding prevents unduly rapid metabolism, allowing the hormone to exist for the length of time necessary to ensure a biologic effect. This reservoir-like mechanism avoids peaks and valleys in hormone levels and allows a more steady state of hormone action.

The biologic and metabolic effects of a hormone are determined by a cell's ability to receive and retain the hormone. The estradiol that is not bound to a protein, but floats freely in the bloodstream, readily enters cells by rapid diffusion. For estradiol to produce its effect, however, it must be grasped by a receptor within the cell. The job of

the receptor is to aid in the transmission of the hormone's message to nuclear gene transcription. The result is production of messenger RNA leading to protein synthesis and a cellular response characteristic of the hormone.

Once estradiol has accomplished its mission, it is eventually released back into the bloodstream. It is possible that estradiol can perform its duty several times before being cleared from the circulation by metabolism. On the other hand, many molecules are metabolized without ever having the chance to produce an effect. Unlike estradiol, other hormones, such as testosterone, can either work directly or are metabolized and altered within the cell in which an effect is produced. In the latter case, a metabolite is released into the bloodstream as an inactive compound. Clearance of steroids from the blood varies according to the structure of the molecules.

Cells that are capable of clearing estradiol from the circulation accomplish this by biochemical means (conversion to estrone and estriol, moderately effective and very weak estrogens, respectively) and conjugation to products that are water soluble and excreted in the urine and bile (sulfo- and glucuroconjugates).

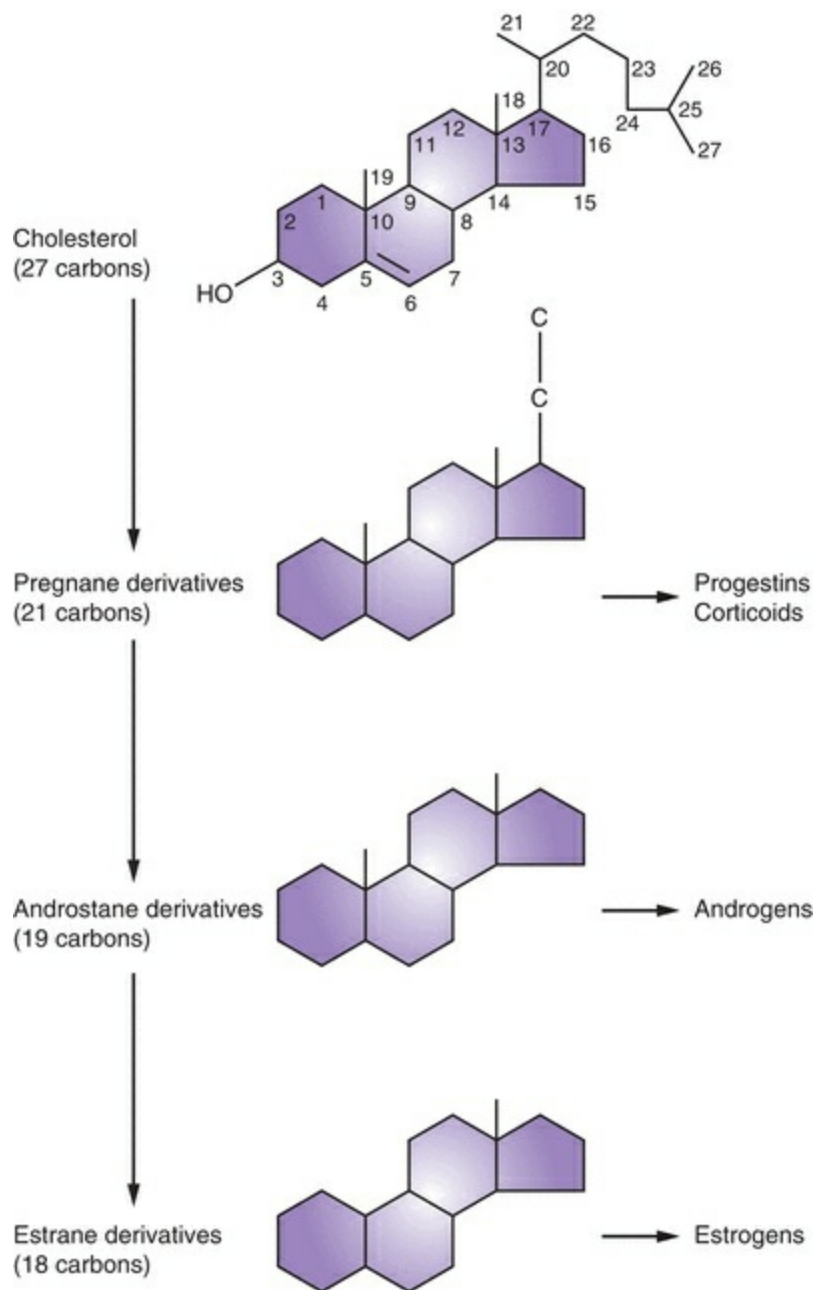
Thus, a steroid hormone has a varied career packed into a short lifetime. In this chapter, we will review the important segments of this life span in greater detail, as well as explore the mechanisms by which tropic hormones regulate steroid hormones.

# STEROID HORMONE NOMENCLATURE

---

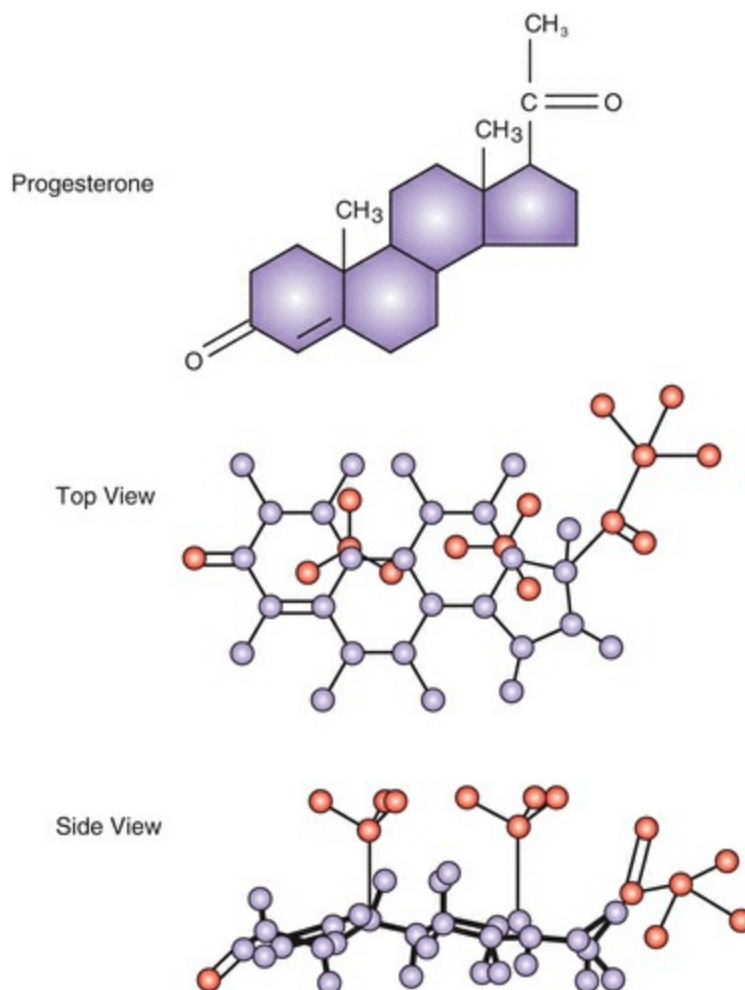
All steroid hormones are of basically similar structure with relatively minor chemical differences leading to striking alterations in biochemical activity. The basic structure is the perhydrocyclopentanophenanthrene molecule. It is composed of three 6-carbon rings and one 5-carbon ring. One 6-carbon ring is benzene, two of the 6-carbon rings are naphthalene, and three 6-carbon rings are phenanthrene; add a cyclopentane (5-carbon ring), and you have the perhydrocyclopentanophenanthrene structure of the steroid nucleus.

The sex steroids are divided into three main groups according to the number of carbon atoms they possess. The 21-carbon series includes the corticoids as well as the progestins, and the basic structure is the **pregnane** nucleus. The 19-carbon series includes all the androgens and is based on the **androstane** nucleus, whereas the estrogens are 18-carbon steroids based on the **estrane** nucleus (**Figure 1.1**).



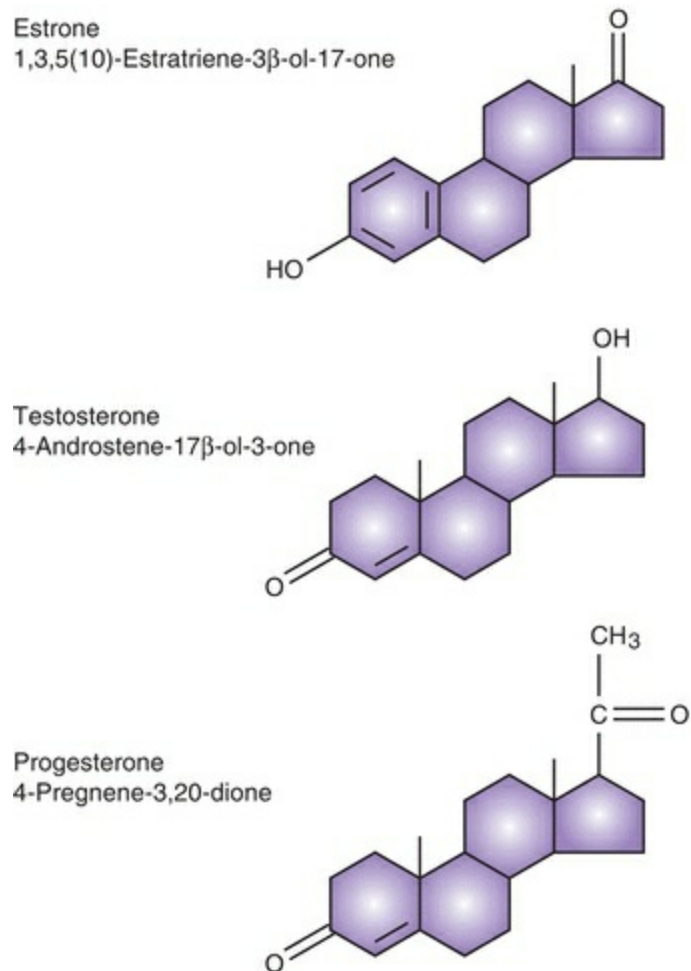
**FIGURE 1.1**

There are six centers of asymmetry on the basic ring structure, and there are 64 possible isomers. Almost all naturally occurring and active steroids are nearly flat, and substituents below and above the plane of the ring are designated alpha ( $\alpha$ ) (dotted line) and beta ( $\beta$ ) (solid line), respectively. Changes in the position of only one substituent can lead to inactive isomers. For example, 17-epitestosterone is considerably weaker than testosterone; the only difference being a hydroxyl group in the  $\alpha$ -position at C-17 rather than in the  $\beta$ -position ([Figure 1.2](#)).



**FIGURE 1.2**

The convention of naming steroids uses the number of carbon atoms to designate the basic name (e.g., pregnane, androstane, or estrane). The basic name is preceded by numbers that indicate the position of double bonds, and the name is altered as follows to indicate one, two, or three double bonds: -ene, -diene, and -triene. Following the basic name, hydroxyl groups are indicated by the number of the carbon attachment, and one, two, or (Figure 1.3) three hydroxyl groups are designated -ol, -diol, or -triol. Ketone groups are listed last with numbers of carbon attachments, and one, two, or three groups designated -one, -dione, or -trione. Special designations include deoxy- (elimination of oxygen), nor- (elimination of carbon), and  $\Delta$ - (location of double bond).



**FIGURE 1.3**



# STEROIDOGENESIS

---

The production of all three major groups of sex steroids is achieved through a common pathway, which begins with the cholesterol molecule. In this section, we will discuss this biosynthesis from the production and uptake of cholesterol through the synthesis of each of the sex steroids.

# LIPOPROTEINS AND CHOLESTEROL

---

Cholesterol is the basic building block in steroidogenesis. All steroid-producing organs except the placenta can synthesize cholesterol from acetate. Progestins, androgens, and estrogens, therefore, can be synthesized in situ in the various ovarian tissue compartments from the 2-carbon acetate molecule via cholesterol as the common steroid precursor. However, in situ synthesis cannot meet the demand, and, therefore, the major resource is blood cholesterol that enters the ovarian cells and can be inserted into the biosynthetic pathway or stored in esterified form for later use. The cellular entry of cholesterol is mediated via a cell membrane receptor for low-density lipoprotein (LDL), the bloodstream carrier for cholesterol.

Lipoproteins are large molecules that facilitate the transport of nonpolar fats in a polar solvent, the blood plasma. There are five major categories of lipoproteins according to their charge and density (flotation during ultracentrifugation). They are derived from each other in the following cascade of decreasing size and increasing density.

# Chylomicrons

Large, cholesterol (10%)- and triglyceride (90%)-carrying particles formed in the intestine after a fatty meal.

# **Very-Low-Density Lipoproteins**

Also carry cholesterol, but mostly triglyceride; more dense than chylomicrons.

# **Intermediate-Density Lipoproteins (IDLs)**

Formed (for a transient existence) with the removal of some of the triglyceride from the interior of very-low-density lipoprotein (VLDL) particles.

# **Low-Density Lipoproteins**

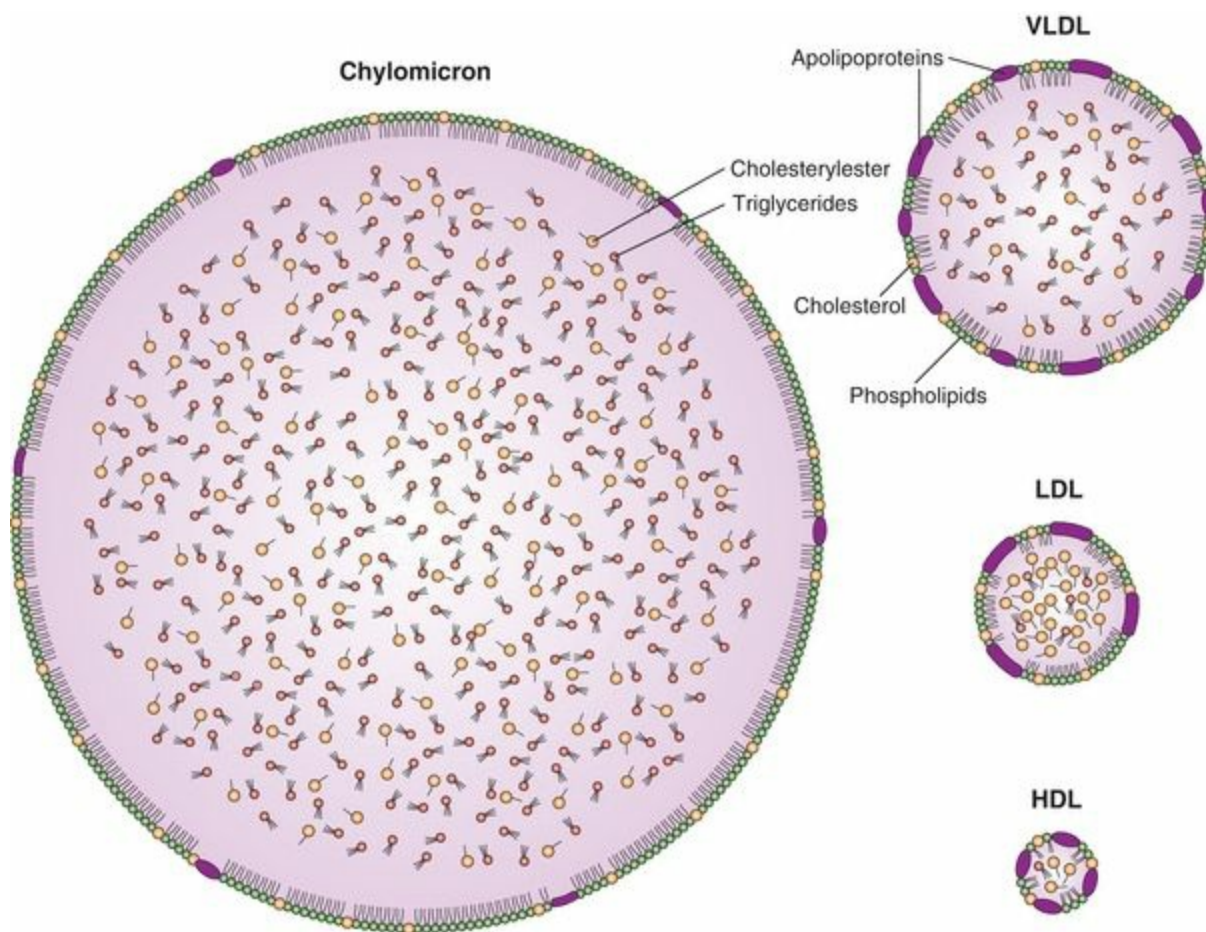
The end products of VLDL catabolism, formed after further removal of triglyceride leaving approximately 50% cholesterol; the major carriers (two-thirds) of cholesterol in the plasma (and thus a strong relationship exists between elevated LDL levels and cardiovascular disease).

# High-Density Lipoproteins

The smallest and most dense of the lipoproteins with the highest protein and phospholipid content; high-density lipoprotein (HDL) levels are inversely associated with atherosclerosis (high levels are protective). HDL can be further separated into a lighter fraction (HDL<sub>2</sub>) and a denser fraction (HDL<sub>3</sub>).

The lipoproteins contain four ingredients: (1) cholesterol in two forms, free cholesterol on the surface of the spherical lipoprotein molecule and esterified cholesterol in the molecule's interior; (2) triglycerides in the interior of the sphere; (3) phospholipid; and (4) protein in electrically charged substances on the surface of the sphere and responsible for miscibility with plasma and water. The surface proteins, called **apoproteins**, constitute the sites that bind to the lipoprotein receptor molecules on the cell surfaces. The principal surface protein of LDL is apoprotein B, and apoprotein A-1 is the principal apoprotein of HDL.

Lipids for peripheral tissues are provided by the secretion of VLDL by the liver. Triglycerides are liberated from VLDL by lipoprotein lipase located in the capillary endothelial cells as well as a lipase enzyme located on the endothelial cells in liver sinusoids. In this process, the surface components (free cholesterol, phospholipids, and apoproteins) are transferred to HDL. Finally, the VLDL is converted to LDL, which plays an important role of transporting cholesterol to cells throughout the body. The hepatic lipase enzyme is sensitive to sex steroid changes; it is suppressed by estrogen and stimulated by androgens (**Figure 1.4**).



**FIGURE 1.4**

LDL is removed from the blood by cellular receptors that recognize one of the surface apoproteins. The lipoprotein bound to the cell membrane receptor is internalized and degraded. Intracellular levels of cholesterol are partly regulated by the up- and down-regulation of cell membrane LDL receptors. When these LDL receptors are saturated or deficient, LDL is taken up by “scavenger” cells (most likely derived from macrophages) in other tissues, notably the arterial intima. Thus, these cells can become the nidus for atherosclerotic plaques.

HDL is secreted by the liver and intestine or is a product of the degradation of VLDL. Cholesteryl ester molecules move to form a core in a small spherical particle, the HDL<sub>3</sub> particle. These particles accept additional free cholesterol, perhaps mediated by receptors that recognize apoprotein A-1. With uptake of cholesterol, the particle size increases to form HDL<sub>2</sub>, the fraction that reflects changes in diet and hormones. HDL<sub>3</sub> levels remain relatively stable.

The protein moieties of the lipoprotein particles are strongly related to the risk of cardiovascular disease, and genetic abnormalities in their synthesis or structure can



result in atherogenic conditions. The lipoproteins are a major reason for the disparity in atherosclerosis risk between men and women. Throughout adulthood, the blood HDL cholesterol level is about 10 mg/dL higher in women, and this difference continues through the postmenopausal years. Total and LDL cholesterol levels are lower in premenopausal women than in men, but after menopause, they rise rapidly.

The protective nature of HDL is due to its ability to pick up free cholesterol from cells or other circulating lipoproteins. This lipid-rich HDL is known as HDL<sub>3</sub>, which is then converted to the larger, less dense particle, HDL<sub>2</sub>. Thus, HDL converts lipid-rich scavenger cells (macrophages residing in arterial walls) back to their low-lipid state and carries the excess cholesterol to sites (mainly liver) where it can be metabolized. Another method by which HDL removes cholesterol from the body focuses on the uptake of free cholesterol from cell membranes. The free cholesterol is esterified and moves to the core of the HDL particle. Thus, HDL can remove cholesterol by delivering cholesterol to sites for utilization (steroid-producing cells) or metabolism and excretion (liver).

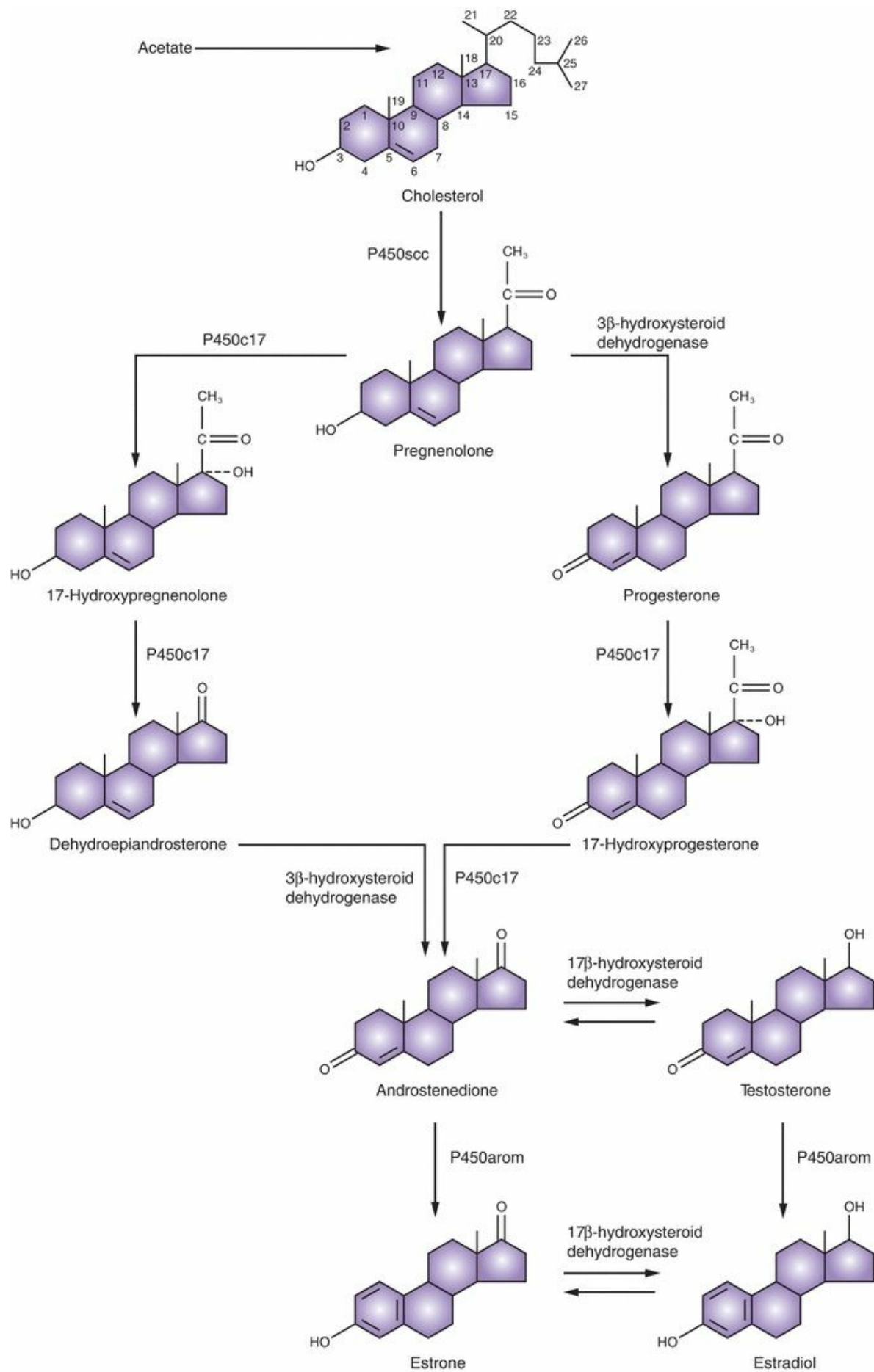
For good cardiovascular health, the blood concentration of cholesterol must be kept low, and its escape from the bloodstream must be prevented. The problem of cholesterol transport is solved by esterifying the cholesterol and packaging the ester within the cores of plasma lipoproteins. The delivery of cholesterol to cells is in turn solved by lipoprotein receptors. After binding the lipoprotein with its package of esterified cholesterol, the complex is delivered into the cell by receptor-mediated endocytosis (discussed later in this chapter), in which the lysosomes liberate cholesterol for use by the cell.

Major protection against atherosclerosis depends on the high affinity of the receptor for LDL and the ability of the receptor to recycle multiple times, thus allowing large amounts of cholesterol to be delivered while maintaining a healthy low blood level of LDL. Cells can control their uptake of cholesterol by increasing or decreasing the number of LDL receptors according to the intracellular cholesterol levels. Thus, a high-cholesterol diet influences the liver to reduce the number of LDL receptors on its cells, causing an elevated blood level of LDL. Statins protect against atherosclerosis by reducing cholesterol biosynthesis, increasing LDL receptors in the liver, and lowering circulating levels of LDL cholesterol.

# STEROID BIOSYNTHETIC PATHWAY

---

The overall steroid biosynthesis pathway shown in [Figure 1.5](#) is based primarily on the pioneering work of Kenneth J. Ryan and his coworkers.<sup>1,2</sup> These pathways follow a fundamental pattern displayed by all steroid-producing endocrine organs. As a result, it should be no surprise that the normal human ovary produces all three classes of sex steroids: estrogens, progestins, and androgens. The importance of ovarian androgens is appreciated, not only as obligate precursors to estrogens but also as clinically important secretory products. The ovary differs from the testis in its fundamental complement of critical enzymes and, hence, its distribution of secretory products. The ovary is distinguished from the adrenal gland in that it is deficient in 21-hydroxylase and 11 $\beta$ -hydroxylase reactions. Glucocorticoids and mineralocorticoids, therefore, are not produced in normal ovarian tissue.



## FIGURE 1.5

During steroidogenesis, the number of carbon atoms in cholesterol or any other steroid molecule can be reduced but never increased. The following reactions can take place:

- 1. Cleavage of a side chain (desmolase reaction)**
- 2. Conversion of hydroxy groups into ketones or ketones into hydroxy groups (dehydrogenase reactions)**
- 3. Addition of hydroxy group (hydroxylation reaction)**
- 4. Creation of double bonds (removal of hydrogen)**
- 5. Addition of hydrogen to reduce double bonds (saturation)**

The traditional view of steroidogenesis was that each step was mediated by many enzymes, with differences from tissue to tissue. A fundamental simplicity to the system emerged when the responsible complementary DNAs and genes were cloned.<sup>3,4,5</sup>

Steroidogenic enzymes are either dehydrogenases or members of the cytochrome P450 group of oxidases. Cytochrome P450 is a generic term for a family of oxidative enzymes, termed 450 because of a pigment (450) absorbance shift when reduced. P450 enzymes can metabolize many substrates; for example, in the liver, P450 enzymes metabolize toxins and environmental pollutants. The human genome contains genes for 57 cytochrome P450 enzymes; 7 of these enzymes localize to the mitochondria and 50 to the endoplasmic reticulum (the major site for metabolic clearance). The following distinct P450 enzymes are involved in steroidogenesis: P450scc is the cholesterol side-chain cleavage enzyme; P450c11 mediates 11-hydroxylase, 18-hydroxylase, and 19-methyloxidase; P450c17 mediates 17-hydroxylase and 17,20-lyase; P450c21 mediates 21-hydroxylase; and P450arom mediates aromatization of androgens to estrogens ([Table 1.1](#)). Marked differences in the exon-intron organization of the P450 genes are compatible with an ancient origin; thus, the superfamily of P450 genes diverged more than 1.5 billion years ago.

### TABLE 1.1 Cytochrome P450 Enzymes

<b>Enzyme</b>	<b>Cellular Location</b>	<b>Reactions</b>
P450scc	Mitochondria	Cholesterol side-chain cleavage
P450c11	Mitochondria	11-Hydroxylase 18-Hydroxylase 19-Methyloxidase
P450c17	Endoplasmic reticulum	17-Hydroxylase, 17,20-lyase
P450c21	Endoplasmic reticulum	21-Hydroxylase
P450arom	Endoplasmic reticulum	Aromatase

The structural knowledge of the P450 enzymes that has been derived from amino acid and nucleotide sequencing studies demonstrated that all the steps between cholesterol and pregnenolone were mediated by a single protein, P450scc, bound to the inner mitochondrial membrane. Cloning data revealed that this protein is encoded by the CYP11A1 gene on chromosome 15. These experiments indicated that multiple steps did not require multiple enzymes. Differing activity in different tissues may reflect posttranslational modifications. In addition, P450-encoding genes contain tissue-specific promoter sequences, which is another reason that regulatory mechanisms can differ in different tissues (e.g., placenta and ovary). CYP11A1 mutations are very rare, producing impaired steroidogenesis in both the adrenal glands and the gonads and causing abnormal sexual development and adrenal failure.<sup>6</sup>

Conversion of cholesterol to pregnenolone involves hydroxylation at the carbon 20 and 22 positions, with subsequent cleavage of the side chain. Conversion of cholesterol to pregnenolone by P450scc takes place within the mitochondria. It is one of the principal effects of tropic hormone stimulation, which also causes the uptake of the cholesterol substrate for this step in the ovary. The tropic hormones from the anterior

pituitary bind to the cell surface receptor of the G protein system, activate adenylate cyclase, and increase intracellular cyclic AMP. Cyclic AMP activity leads to gene transcription that encodes the steroidogenic enzymes and accessory proteins. In a process that is faster than gene transcription, cyclic AMP stimulates the hydrolysis of cholesteryl esters and the transport of free cholesterol to the mitochondria.

The cholesterol used for steroid synthesis is derived from circulating LDLs, followed by the mobilization and transport of intracellular stores.<sup>5,7,8</sup> LDL cholesterol esters are incorporated into the cell by tropic hormone stimulation of endocytosis via clathrin-coated pits (a mechanism discussed later in this chapter). Cholesterol is stored in the cell in the ester form or as free cholesterol. Indeed, the rate-limiting step in steroidogenesis is the transfer of cholesterol from the outer mitochondrial membrane to the inner mitochondrial membrane where fully active P450<sub>scc</sub> waits for substrate. The rate-limiting transfer of hydrophobic cholesterol through the aqueous space between the outer and inner mitochondrial membranes is mediated by protein activation stimulated by the tropic hormone. Long-term, chronic steroidogenesis requires gene transcription and protein synthesis, but short-term, acute responses occur independently of new RNA synthesis (although protein synthesis is still necessary—specifically the proteins that regulate cholesterol transfer across the mitochondrial membrane).

Several proteins have been characterized and proposed as regulators of acute intracellular cholesterol transfer. Sterol carrier protein 2 (SCP2) is able to bind and transfer cholesterol between compartments within a cell. Another candidate is a small molecule, steroidogenesis activator polypeptide (SAP), and still another is peripheral benzodiazepine receptor (PBR), which affects cholesterol flux through a pore structure. But the most studied and favored protein as a regulator of acute cholesterol transfer is **steroidogenic acute regulatory (StAR) protein**.<sup>9,10,11,12,13</sup> StAR messenger RNA and proteins are induced concomitantly with acute steroidogenesis in response to cyclic AMP stimulation. StAR protein increases steroid production and is imported and localized in the mitochondria. Congenital lipoid adrenal hyperplasia (an autosomal recessive disorder) is a failure in adrenal and gonadal steroidogenesis due to a variety of mutations in the StAR gene.<sup>14,15</sup> With several of these mutations, a low level of steroidogenesis is possible, even permitting feminization at puberty, but continuing tropic hormonal stimulation results in an accumulation of intracellular lipid deposits that destroy steroidogenic capability.<sup>16</sup> Mutations of the StAR gene are the only inherited disorder of steroidogenesis not caused by a defect in one of the steroidogenic enzymes.

StAR is required for adrenal and gonadal steroidogenesis (for which it mediates the transport of cholesterol into mitochondria) and, therefore, is necessary for normal male sexual differentiation. StAR moves cholesterol from the outer mitochondrial membrane

to the inner mitochondrial membrane where it can enter the steroidogenic pathway by being converted to pregnenolone. A group of proteins structurally related to StAR have been identified, designated StARD4, StARD5, and StARD6. StARD4 is responsible for binding free cholesterol as it is produced in the cytoplasm and transporting it to the outer mitochondrial membrane.<sup>12</sup> Because steroid-producing cells do not store large amounts of hormones, acute increases in secretion depend on this system to produce rapid synthesis.

Once pregnenolone is formed, further steroid synthesis in the ovary can proceed by one of two pathways, either via  $\Delta^5$ -3 $\beta$ -hydroxysteroids or via the  $\Delta^4$ -3-ketone pathway. The first (the  $\Delta^5$  pathway) proceeds by way of pregnenolone and dehydroepiandrosterone (DHEA) and the second (the  $\Delta^4$  pathway) via progesterone and 17 $\alpha$ -hydroxyprogesterone.

The conversion of pregnenolone to progesterone involves two steps: the 3 $\beta$ -hydroxysteroid dehydrogenase and  $\Delta^{4-5}$  isomerase reactions that convert the 3-hydroxyl group to a ketone and transfer the double bond from the 5–6 position to the 4–5 position. The 3 $\beta$ -hydroxysteroid dehydrogenase enzyme catalyzes both the dehydrogenation and isomerization reactions and exists in two forms (type I and type II), encoded by two separate genes on chromosome 1 (the type I gene is expressed in the placenta, breast, and other nonglandular tissues, while the type II gene is expressed in the gonads and the adrenal glands). Once the  $\Delta^{4-5}$  ketone is formed, progesterone is hydroxylated at the 17 position to form 17 $\alpha$ -hydroxyprogesterone. 17 $\alpha$ -Hydroxyprogesterone is the immediate precursor of the C-19 (19 carbons) series of androgens in this pathway. By peroxide formation at C-20, followed by epoxidation of the C-17, C-20 carbons, the side chain is split off, forming androstenedione. The 17-ketone may be reduced to a 17 $\beta$ -hydroxy to form testosterone by the 17 $\beta$ -hydroxysteroid dehydrogenase reaction. Both C-19 steroids (androstenedione and testosterone) can be converted to corresponding C-18 phenolic steroid estrogens (estrone and estradiol) by microsomal reactions in a process referred to as aromatization. This process includes hydroxylation of the angular 19-methyl group, followed by oxidation, loss of the 19-carbon as formaldehyde, and ring A aromatization (dehydrogenation). As an alternative, pregnenolone can be directly converted to the  $\Delta^5$ -3 $\beta$ -hydroxy C-19 steroid, DHEA, by 17 $\alpha$ -hydroxylation followed by cleavage of the side chain. With formation of the  $\Delta^4$ -3-ketone, DHEA is converted into androstenedione.

The four reactions involved in converting pregnenolone and progesterone to their 17-hydroxylated products are mediated by a single enzyme, P450c17, bound to smooth endoplasmic reticulum and encoded by the CYP17A1 gene on chromosome 10q24.32. 17-Hydroxylase and 17,20-lyase were historically thought to be separate enzymes; however, these two different functions of the single P450c17 enzyme are not genetic or

structural but represent the effect of posttranslational influencing factors.<sup>17</sup> In the adrenal gland pathway to cortisol, very little 17,20-lyase activity is expressed. In the ovarian theca cells, the testicular Leydig cells, and the adrenal reticularis, both 17-hydroxylase and 17,20-lyase activities are expressed, directing the steroidogenic pathway via DHEA. In the corpus luteum, the principal pathway is via progesterone.

Hydroxylation of progesterone and 17 $\alpha$ -hydroxyprogesterone is mediated by the P450c21 protein, also known as 21-hydroxylase. Characterization of this protein and gene cloning indicate that its encoding gene, CYP21, is located on chromosome 6p21.3. An inactive pseudogene, CYP21P, is nearby. Many of the mutations that affect CYP21 and cause congenital adrenal hyperplasia are gene conversions involving recombinations between CYP21 and inactivating mutations in CYP21P.

Aromatization is mediated by P450arom found in the endoplasmic reticulum.<sup>18,19</sup> Aromatase cytochrome P450 is encoded by the CYP19A1 (cytochrome P450; family 19—denoting oxidation of the C-19 methyl group; subfamily A; polypeptide 1) gene on chromosome 15q21.1. Aromatization in different tissues with different substrates is the result of the single P450arom enzyme encoded by this single gene. Aromatase deficiency because of an inactivating mutation of CYP19A1 is very rare; only a handful of cases have been reported.<sup>20</sup> Affected females present at birth with virilization because the placenta cannot convert fetal adrenal androgens to estrogens; thus, maternal virilization during the pregnancy is usually also present.

Aromatase transcription is regulated by several promoter sites that respond to cytokines, cyclic nucleotides, gonadotropins, glucocorticoids, and growth factors.<sup>21</sup> Tissue-specific expression is regulated by tissue-specific promoters that allow the extremes of highly regulated expression in the ovary in response to cyclic AMP and gonadotropins, expression in adipose tissue stimulated by prostaglandin E<sub>2</sub>, and nonregulated expression in the placenta and adipose. Very specific inhibitors of P450arom have been developed, called “aromatase inhibitors,” that allow intense blockage of estrogen production, with clinical applications that include the treatment of breast cancer (e.g., anastrozole and letrozole) and ovulation induction. The aromatase complex also includes NADPH-cytochrome P450 reductase, a ubiquitous flavoprotein involved in reduction reactions.

The 17 $\beta$ -hydroxysteroid dehydrogenase and 5 $\alpha$ -reductase reactions are mediated by non-P450 enzymes. The 17 $\beta$ -hydroxysteroid dehydrogenase is bound to the endoplasmic reticulum and the 5 $\alpha$ -reductase to the nuclear membrane. The 17 $\beta$ -hydroxysteroid dehydrogenase enzymes convert estrone to estradiol, androstenedione to testosterone, and DHEA to androstenediol, and vice versa. Eight different isozymes have been cloned and characterized.<sup>22</sup> The type 1 enzyme is active in the placenta and granulosa cells, converting estrone to estradiol. The type 2 and 4 enzymes, found in many tissues, form

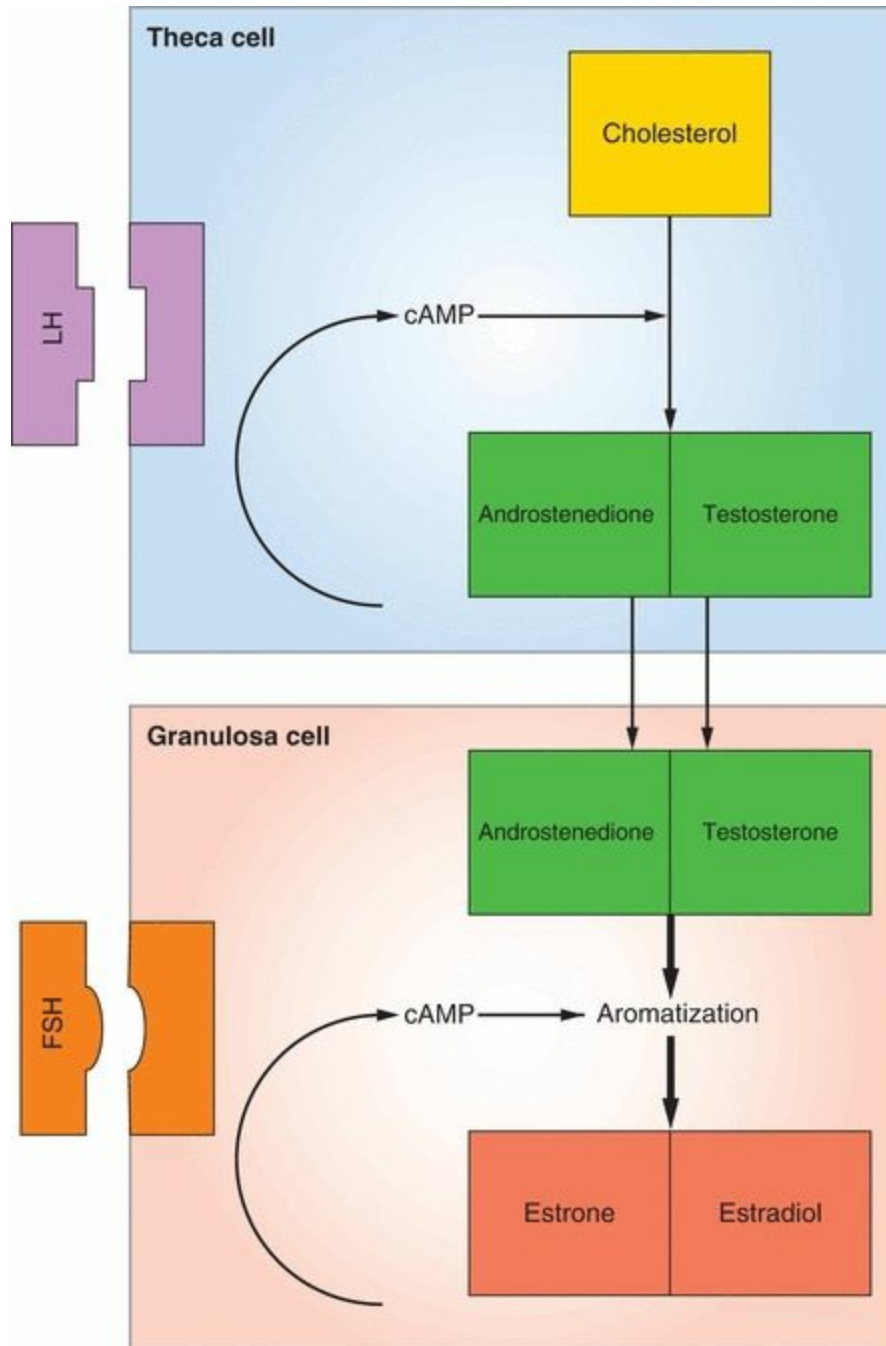


androstenedione and estrone from testosterone and estradiol, respectively. The type 3 and 5 enzymes in the testis reduce androstenedione to testosterone. The type 6 enzyme may be found only in rodents, and the type 7 and 8 enzymes are widespread, but have limited activity. Thus, types 1, 3, and 5 form active estrogens and androgens, whereas types 2 and 4 produce weaker products, a form of inactivation. This is important, for example, in protecting the fetus against testosterone and estradiol in the maternal circulation. The cell-specific production of each of these isoforms is a method for regulating the local concentration of estrogens and androgens.

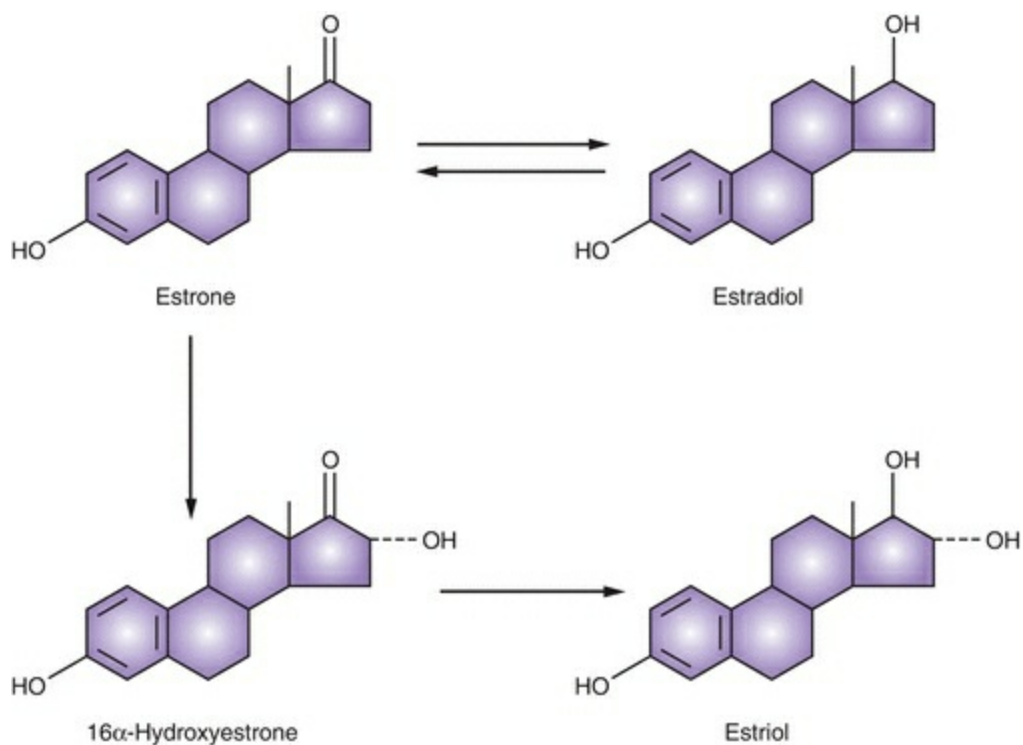
# ESTROGENS

---

Androgens are the precursors of estrogens.  $17\beta$ -Hydroxysteroid dehydrogenase activity converts androstenedione to testosterone, which is not a major secretory product of the normal ovary. It is rapidly demethylated at the C-19 position and aromatized to estradiol, the major estrogen secreted by the human ovary. This process involves the well-characterized “two-cell system” described at length in [Chapter 5](#), ([Figure 1.6](#)). Estradiol also arises to a major degree from androstenedione via estrone, and estrone itself is secreted in significant daily amounts. Estriol is the peripheral metabolite of estrone and estradiol and not a secretory product of the ovary. The formation of estriol is typical of general metabolic “detoxification” (i.e., the conversion of biologically active material to less active forms) ([Figure 1.7](#)).

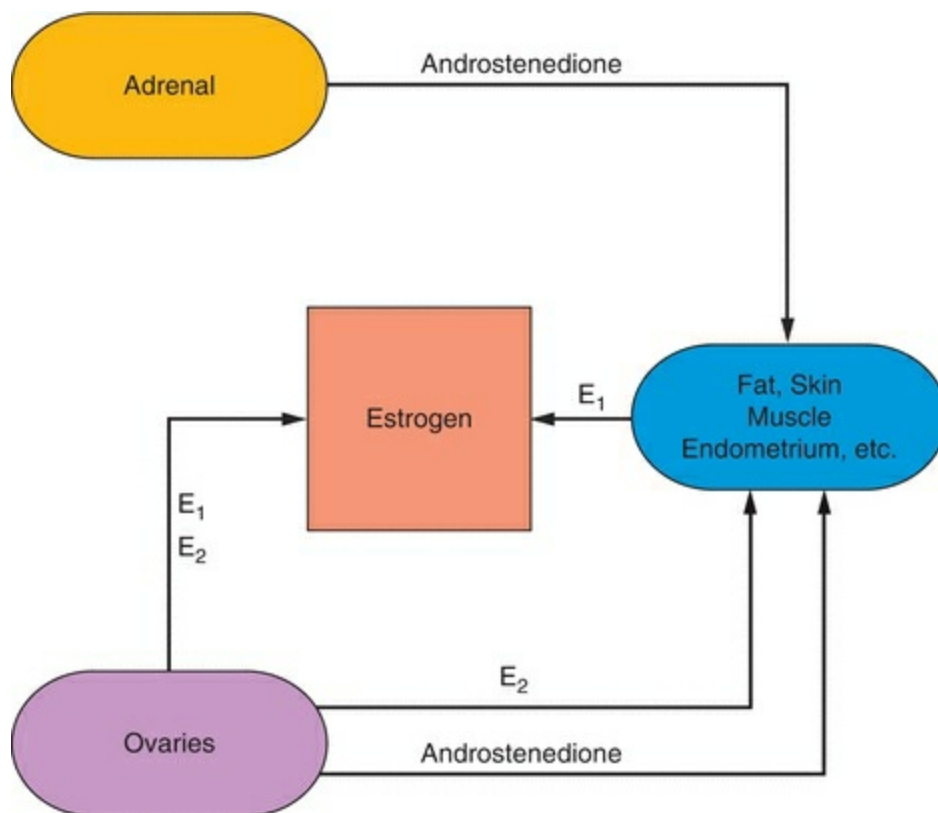


**FIGURE 1.6**



**FIGURE 1.7**

The conversion of steroids in peripheral tissues is not always a form of inactivation. Free androgens are peripherally converted to free estrogens, for example, in the skin and adipose cells. The location of the adipose cells influences their activity. Women with central obesity produce more androgens.<sup>23</sup> The work of Siiteri and MacDonald<sup>24</sup> demonstrated that enough estrogen can be derived from circulating androgens to produce bleeding in the postmenopausal woman. In the female, the adrenal gland remains the major source of circulating androgens, particularly androstenedione (**Figure 1.8**). In the male, almost all of the circulating estrogens are derived from peripheral conversion of androgens. The precursor androgens consist principally of androstenedione, DHEA, and dehydroepiandrosterone sulfate.



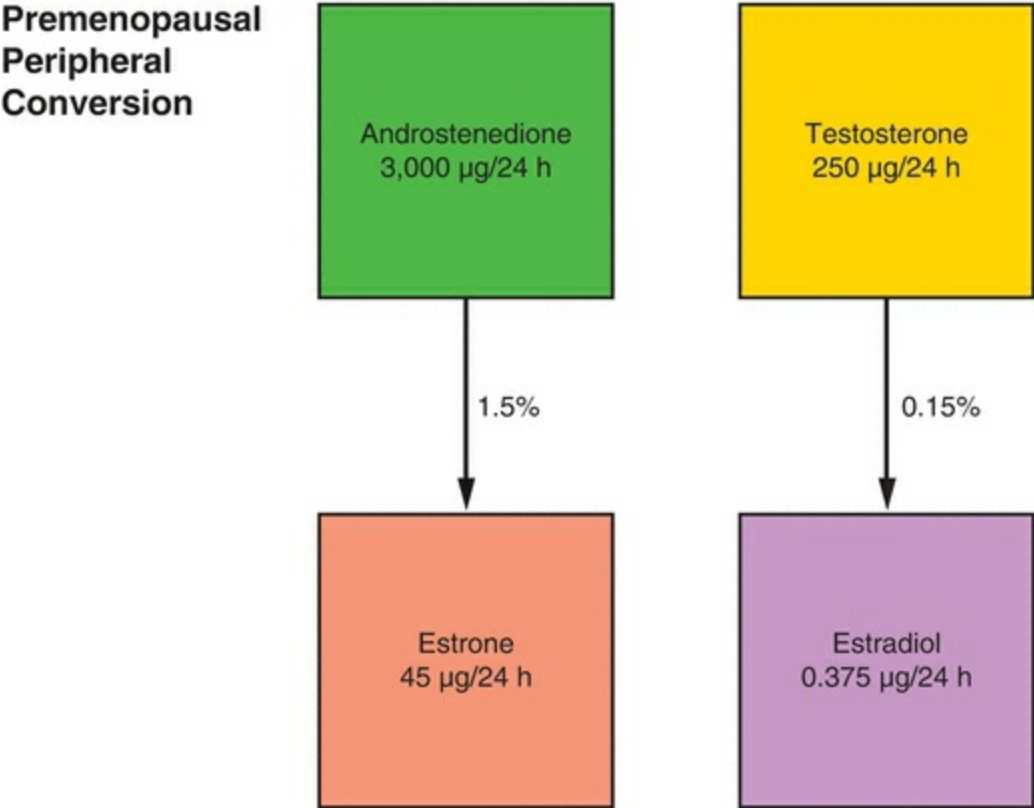
**FIGURE 1.8**

It can be seen, therefore, that the pattern of circulating steroids in the female is influenced by the activity of various processes outside the ovary. Because of the peripheral contribution to steroid levels, the term secretion rate is reserved for direct organ secretion, whereas production rate includes organ secretion plus peripheral contribution via conversion of precursors. The metabolic clearance rate (MCR) equals the volume of blood that is cleared of the hormone per unit of time. The blood production rate (PR) then equals the MCR multiplied by the concentration of the hormone in the blood.

$$\begin{aligned} \text{MCR} &= \text{Liters/Day} \\ \text{PR} &= \text{MCR} \times \text{Concentration (Liters/Day} \times \text{Amount/Liter} \\ &= \text{Amount/Day)} \end{aligned}$$

In the normal nonpregnant female, estradiol is produced at the rate of 100–300  $\mu\text{g/day}$ , but it circulates and functions within cells in concentrations of  $\text{pg/mL}$ . The production of androstenedione is about 3  $\text{mg/day}$ , and the peripheral conversion (about 1%) of androstenedione to estrone accounts for about 20–30% of the estrone produced per day. Because androstenedione is secreted in milligram amounts, even a small percent conversion to estrogen results in a significant contribution to estrogens, which exist and function in the circulation in picogram amounts. Thus, the circulating estrogens in the

female are the sum of direct ovarian secretion of estradiol and estrone, plus peripheral conversion of C-19 precursors (**Figure 1.9**).

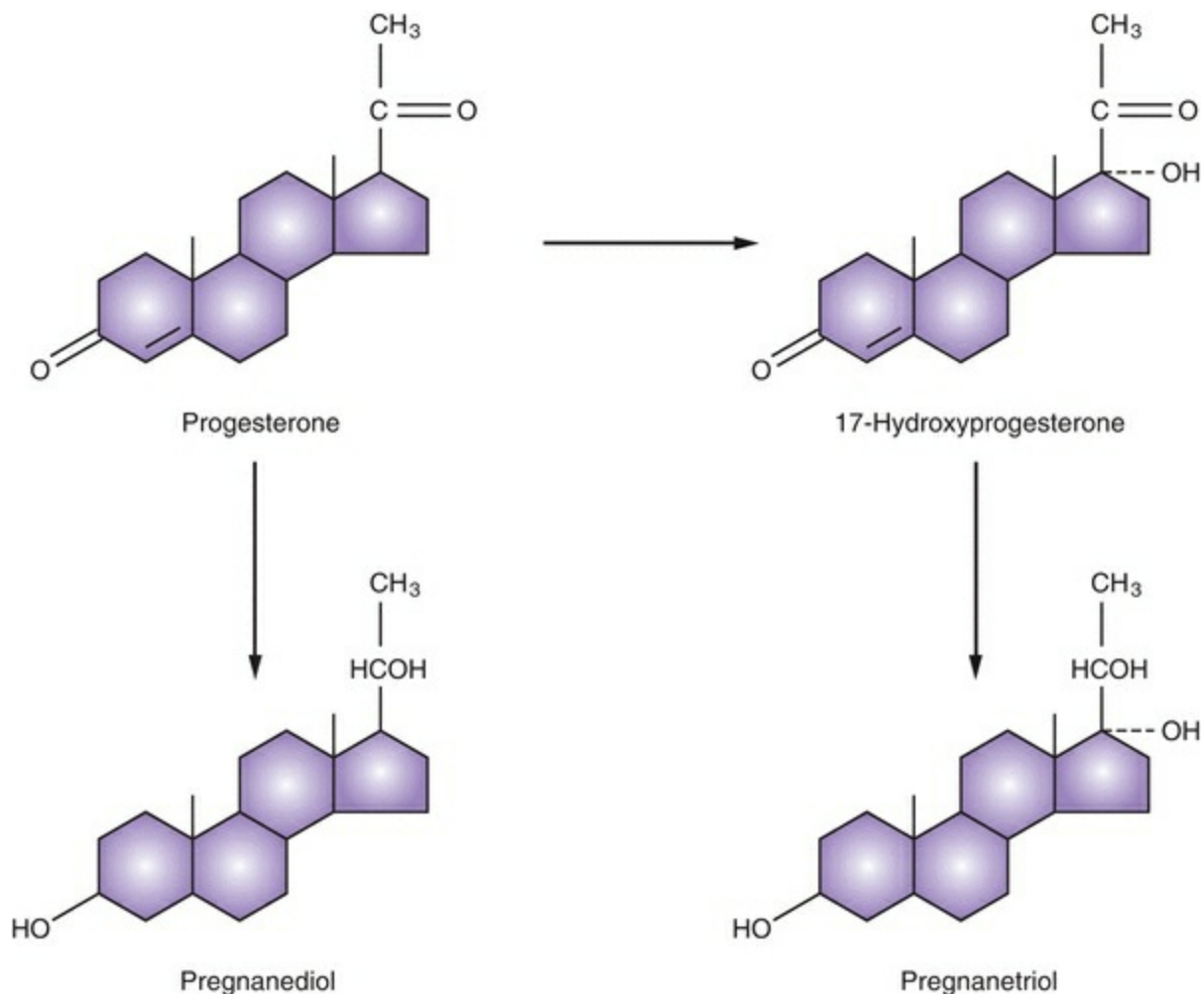


**FIGURE 1.9**

# PROGESTERONE

Peripheral conversion of steroids to progesterone is not seen in the nonpregnant female; rather, the progesterone production rate is a combination of secretion from the adrenal and the ovaries. Including the small contribution from the adrenal, the blood production rate of progesterone in the preovulatory phase is less than 1 mg/day. During the luteal phase, production increases to 20–30 mg/day.

In the preovulatory phase in adult females, in all prepubertal females, and in the normal male, the blood levels of progesterone are at the lower limits of immunoassay sensitivity: less than 1 ng/mL. After ovulation, that is, during the luteal phase, progesterone ranges from 3 to 15 ng/mL. In congenital adrenal hyperplasia, progesterone blood levels can be as high as 50 times above normal. Pregnanediol and Pregnanetriol are metabolites of progesterone that are excreted in the urine ([Figure 1.10](#)).



**FIGURE 1.10**

# ANDROGENS

---

The major androgen products of the ovary are DHEA and androstenedione (and only a little testosterone), which are secreted mainly by stromal tissue derived from theca cells. With excessive accumulation of stromal tissue or in the presence of an androgen-producing tumor, testosterone becomes a significant secretory product. Occasionally, a nonfunctioning tumor can induce stromal proliferation and increased androgen production. The normal accumulation of stromal tissue at midcycle results in a rise in circulating levels of androstenedione and testosterone at the time of ovulation.

The adrenal cortex produces three groups of steroid hormones: the glucocorticoids, the mineralocorticoids, and the sex steroids. The adrenal sex steroids represent intermediate by-products in the synthesis of glucocorticoids and mineralocorticoids, and excessive secretion of the sex steroids occurs only with neoplastic cells or in association with enzyme deficiencies. Under normal circumstances, adrenal gland production of the sex steroids is less significant than gonadal production of androgens and estrogens. About one-half of the daily production of DHEA and androstenedione comes from the adrenal gland. The other half of androstenedione is secreted by the ovary, while the other half of DHEA is secreted almost equally from the ovary and peripheral tissues. The production rate of testosterone in the normal female is 0.2–0.3 mg/day, and approximately 50% arises from peripheral conversion of androstenedione (and a small amount from DHEA) to testosterone, whereas 25% is secreted by the ovary and 25% by the adrenal.

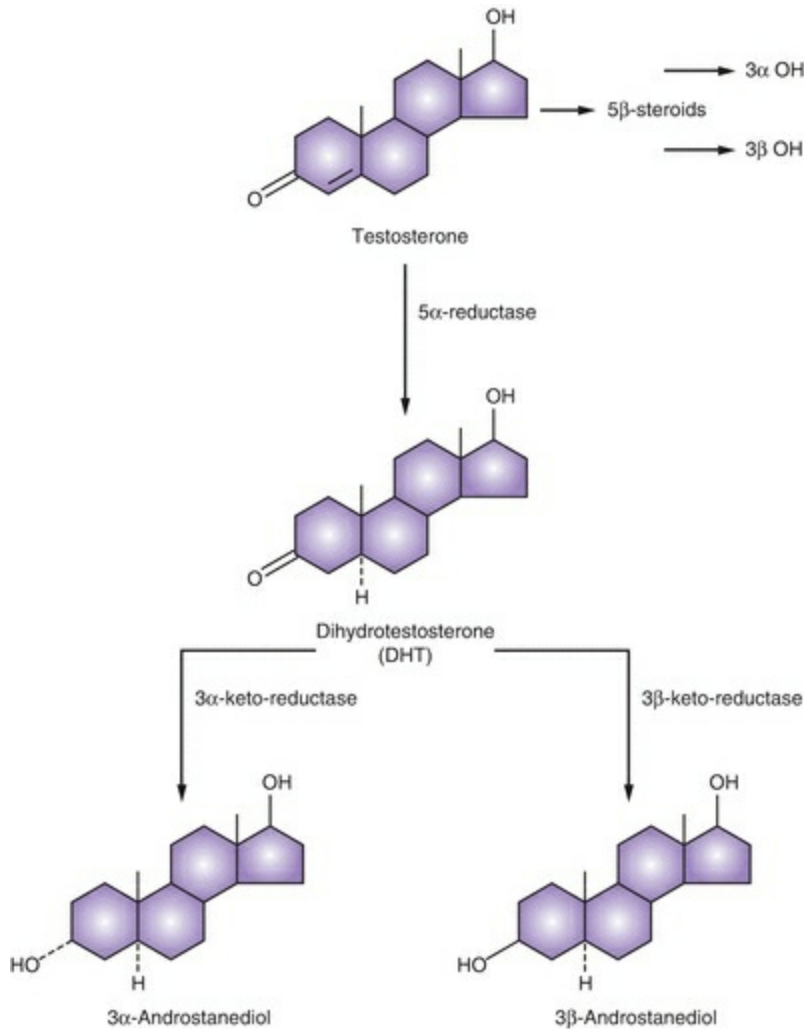
Reduction of the  $\Delta^4$  unsaturation (an irreversible pathway) in testosterone is very significant, producing derivatives very different in their spatial configuration and activity. The  $5\beta$ -derivatives are not androgenic, and this is not a clinically important pathway; however, the  $5\alpha$ -derivative (a very active pathway) is extremely potent. Indeed, dihydrotestosterone (DHT), the  $5\alpha$ -derivative, is the principal androgenic hormone in a variety of target tissues and is formed within the target tissue itself.

In men, the majority of DHT is derived from testosterone that enters a target cell and is converted by means of  $5\alpha$ -reductase. In women, because the production rate of androstenedione is greater than testosterone, DHT is primarily derived from androstenedione and partly from DHEA.<sup>25</sup> Thus, in women, the skin production of DHT is predominantly influenced by androstenedione. DHT is by definition an intracrine hormone, formed and acting within target tissues.<sup>26</sup> The  $5\alpha$ -reductase enzyme exists in two forms, type I and II, each encoded by a separate gene, with the type I enzyme found in the skin and the type II reductase predominantly expressed in reproductive tissues<sup>27</sup>.

DHT is largely metabolized intracellularly; hence, the blood DHT is only about one-tenth the level of circulating testosterone. In tissues sensitive to DHT (which



includes hair follicles), only DHT enters the nucleus to provide the androgen message. DHT also can perform androgenic actions within cells that do not possess the ability to convert testosterone to DHT. DHT is further reduced by a 3 $\alpha$ -keto-reductase to androstenediol, which is relatively inactive. The metabolite of androstenediol, 3 $\alpha$ -androstenediol glucuronide, is the major metabolite of DHT and can be measured in the plasma, indicating the amount of target tissue conversion of testosterone to DHT (Figure 1.11).



**FIGURE 1.11**

Not all androgen-sensitive tissues require the prior conversion of testosterone to DHT. In the process of masculine differentiation, the development of the Wolffian duct structures (epididymis, the vas deferens, and the seminal vesicle) is dependent on testosterone as the intracellular mediator, whereas development of the urogenital sinus and urogenital tubercle into the male external genitalia, urethra, and prostate requires

the conversion of testosterone to DHT.<sup>28</sup> Muscle development is under the direct control of testosterone. Testosterone is also aromatized to a significant extent in the brain, liver, and breast, and in some circumstances (e.g., in the brain), androgenic messages can be transmitted via estrogen.

# BLOOD TRANSPORT OF STEROIDS

---

While circulating in the blood, a majority of the principal sex steroids (i.e., estradiol and testosterone) is bound to a protein carrier known as sex hormone-binding globulin (SHBG), which is produced mainly in the liver. Additionally, 30% is loosely bound to albumin, and a very small percentage binds to corticosteroid-binding globulin, leaving only about 1% unbound and free. Hyperthyroidism, pregnancy, and estrogen administration all increase SHBG levels, whereas corticoids, androgens, progestins, growth hormone, insulin, and insulin-like growth factor I (IGF-I) decrease SHBG.

The circulating level of SHBG is inversely related to body weight, and, thus, significant weight gain can decrease SHBG and produce important changes in the unbound levels of the sex steroids. Additionally, circulating SHBG levels are reduced in the setting of insulin resistance and hyperinsulinemia<sup>29,30</sup>; this, in fact, may be the major mechanism that mediates the impact of increased body weight on SHBG. The relationship between levels of insulin and SHBG is so strong that SHBG concentrations are a marker for hyperinsulinemic insulin resistance, and a low level of SHBG is a predictor for the development of type 2 diabetes mellitus.<sup>31</sup>

The distribution of body fat also has a strong influence on SHBG levels. Android or central fat is located in the abdominal wall and visceral-mesenteric locations. This fat distribution is associated with hyperinsulinemia, hyperandrogenism, and decreased levels of SHBG.<sup>32</sup> The common mechanism for these changes is probably the hyperinsulinemia.

While SHBG is a homodimeric glycoprotein composed of two monomers, it contains a single binding site for androgens and estrogens. Its encoding gene has been localized to the short arm of chromosome 17.<sup>33</sup> Genetic studies have revealed that the SHBG gene also encodes the androgen-binding protein present in the seminiferous tubules, synthesized by the Sertoli cells.<sup>34,35</sup> Dimerization is believed to be necessary to form the single steroid-binding site. Specific genetic abnormalities with decreased or abnormal SHBG have not been reported. SHBG gene expression has now been identified in other tissues (brain, placenta, and endometrium), although a biologic significance has not been determined.

As previously mentioned, SHBG is decreased by androgens; hence, the binding capacity in men is lower than that in normal women. The binding globulin level in women with increased androgen production is also depressed. Androgenic effects are dependent on the unbound fraction that can move freely from the vascular compartment into the target cells. Routine assays determine the total hormone concentration, bound plus free. Thus, a total testosterone concentration can be in the normal range in a woman who is hirsute, but because the binding globulin level is depressed by the androgen

effects, the percent-free and active testosterone is elevated.

Transcortin, also called corticosteroid-binding globulin, is a plasma glycoprotein that binds cortisol, progesterone, deoxycorticosterone, corticosterone, and some of the other minor corticoid compounds. Normally, about 75% of circulating cortisol is bound to transcortin, 15% is loosely bound to albumin, and 10% is unbound or free. Progesterone circulates in the following percentages: less than 2% unbound, 80% bound to albumin, 18% bound to transcortin, and less than 1% bound to SHBG. Binding in the circulation follows the law of mass action: the amount of the free, unbound hormone is in equilibrium with the bound hormone. Thus, the total binding capacity of a binding globulin will influence the amount that is free and unbound.

The biologic effects of the major sex steroids are largely determined by the unbound portion, known as the free hormone. In other words, the active hormone is unbound and free, whereas the bound hormone is relatively inactive. This concept is not without controversy. The hormone-protein complex may be involved in an active uptake process at the target cell plasma membrane.<sup>36,37,38</sup> The albumin-bound fraction of steroids may also be available for cellular action because this binding has low affinity. Because the concentration of albumin in plasma is much greater than that of SHBG, the contribution of the albumin-bound fraction can be significant. Routine assays determine the total hormone concentration, bound plus free, and special steps are required to measure the active free level of testosterone, estradiol, and cortisol.

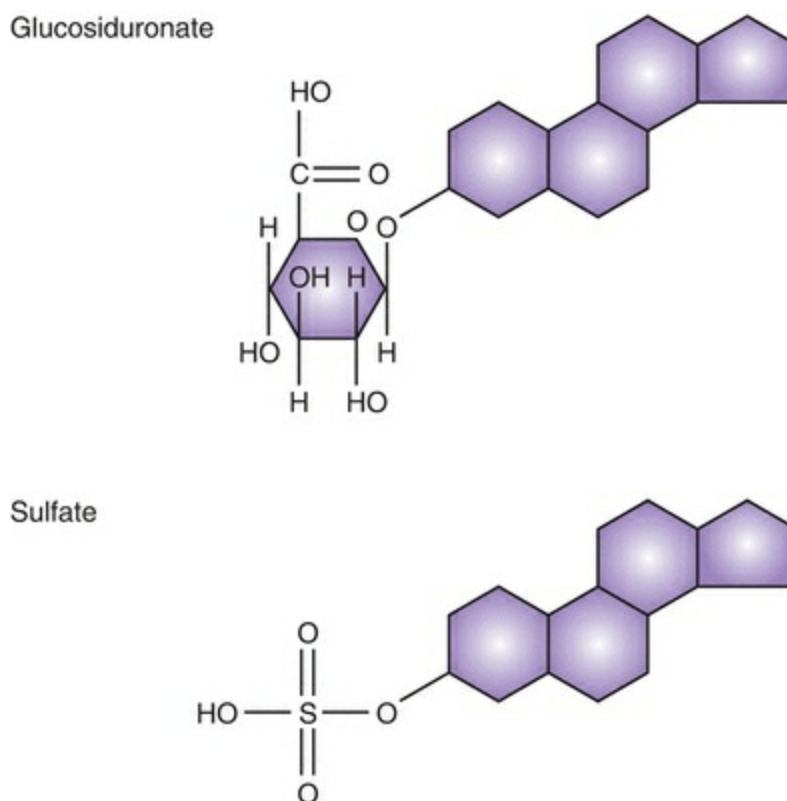
# THE IMPORTANCE OF LOCAL SEX HORMONE PRODUCTION

---

While blood transport of the sex steroids is a key mediator of their biologic effects, it is important to note that the circulating levels of sex hormones do not always reflect concentrations in target cells. In premenopausal women, target tissues synthesize and metabolize most of the testosterone produced. Thus, in women, testosterone functions as a paracrine and intracrine hormone. In men, abundant secretion of testosterone creates circulating levels that are sufficient to allow testosterone to function as a classic hormone. In women, the same description applies to estradiol. Estradiol functions as a classical circulating hormone until menopause, after which both estradiol and testosterone activities are due to local target tissue synthesis, using precursors derived from the circulation. Clinical interventions after menopause, therefore, are directed to local hormone production, for example, the use of aromatase inhibitors to treat breast cancer.

# EXCRETION OF STEROIDS

Active steroids and metabolites are excreted as sulfo- and glucuroconjugates. Conjugation of a steroid converts a hydrophobic compound into a hydrophilic one and generally reduces or eliminates the activity of a steroid. This is not completely true, however, because hydrolysis of the ester linkage can occur in target tissues and restore the active form. Furthermore, estrogen conjugates can have biologic activity, and it is known that sulfated conjugates are actively secreted and may serve as precursors, present in the circulation in relatively high concentrations because of binding to serum proteins. Ordinarily, however, conjugation by the liver and intestinal mucosa is a step in deactivation preliminary to, and essential for, excretion into urine and bile ([Figure 1.12](#)).



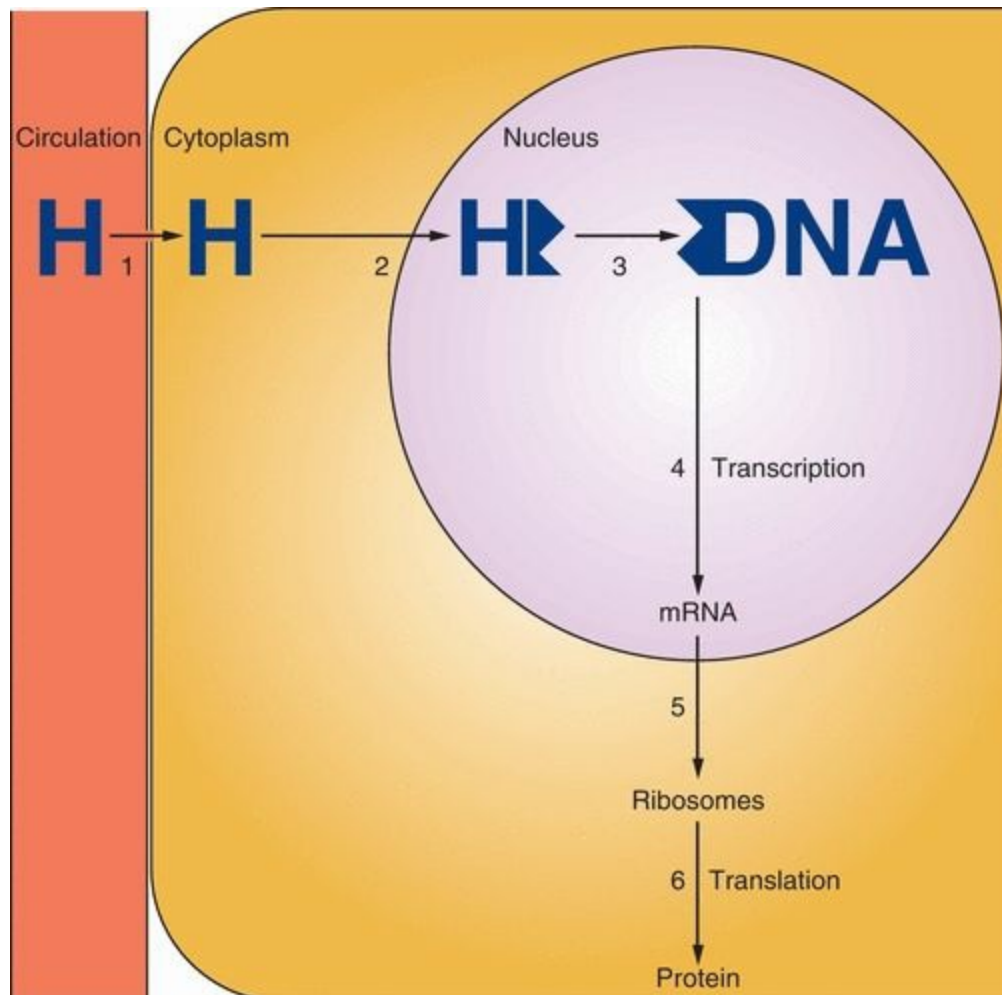
**FIGURE 1.12**

For example, the metabolic fate of progesterone, as expressed by its many excretion products, is relatively complex. About 10–20% of progesterone is excreted as pregnanediol. Pregnanediol glucuronide is present in the urine in concentrations less than 1 mg/day until ovulation. Postovulation pregnanediol excretion reaches a peak of 3–6 mg/day, which is maintained until 2 days prior to menses. The assay of

pregnanediol in the urine now has little clinical use. Pregnanetriol is the chief urinary metabolite of  $17\alpha$ -hydroxyprogesterone and has clinical significance in congenital adrenal hyperplasia, in which an enzymatic defect (most frequently 21-hydroxylase) results in accumulation of  $17\alpha$ -hydroxyprogesterone and increased excretion of pregnanetriol (**Figure 1.10**). However, the plasma or serum assay of  $17\alpha$ -hydroxyprogesterone is a more sensitive and accurate index of this enzyme deficiency than measurement of pregnanetriol.

# MECHANISM OF ACTION FOR STEROID HORMONES

The specificity of the reaction of tissues to sex steroid hormones is due to the presence of intracellular receptor proteins. Different types of tissues, such as liver, kidney, and uterus, respond in a similar manner. The mechanism includes (1) steroid hormone diffusion across the cell membrane, (2) steroid hormone binding to a receptor protein, (3) interaction of a hormone-receptor complex with nuclear DNA, (4) synthesis of messenger RNA (mRNA), (5) transport of the mRNA to the ribosomes, and, finally, (6) protein synthesis in the cytoplasm that results in specific cellular activity (**Figure 1.13**). The steroid hormone receptors primarily affect gene transcription, but also regulate posttranscriptional events and nongenomic events. Steroid receptors regulate gene transcription through multiple mechanisms, not all of which require direct interactions with DNA.



**FIGURE 1.13**



Each of the major classes of the sex steroid hormones, including estrogens, progestins, and androgens, acts according to this general mechanism. Glucocorticoid and mineralocorticoid receptors, when in the unbound state, reside in the cytoplasm and move into the nucleus after hormone-receptor binding. Estrogens, progestins, and androgens are transferred across the nuclear membrane and bind to their receptors within the nucleus.

Steroid hormones are rapidly transported across the cell membrane by simple diffusion. The factors responsible for this transfer are unknown, but the concentration of free (unbound) hormone in the bloodstream seems to be an important and influential determinant of cellular function. Once in the cell, the sex steroid hormones bind to their individual receptors. During this process, **transformation or activation** of the receptor occurs. Transformation refers to a conformational change of the hormone-receptor complex revealing or producing a binding site that is necessary in order for the complex to bind to the chromatin. In the unbound state, the receptor is associated with heat shock proteins that stabilize and protect the receptor and maintain a conformational shape that keeps the DNA-binding region in an inactive state. Activation of the receptor is driven by hormone binding that causes a dissociation of the receptor-heat shock protein complex.

The hormone-receptor complex binds to specific DNA sites (**hormone-responsive elements**) that are located upstream of the gene. The specific binding of the hormone-receptor complex with DNA results in RNA polymerase initiation of transcription. Transcription is followed by translation and mRNA-mediated protein synthesis on the ribosomes. The principal action of steroid hormones is the regulation of intracellular protein synthesis by means of the receptor mechanism.

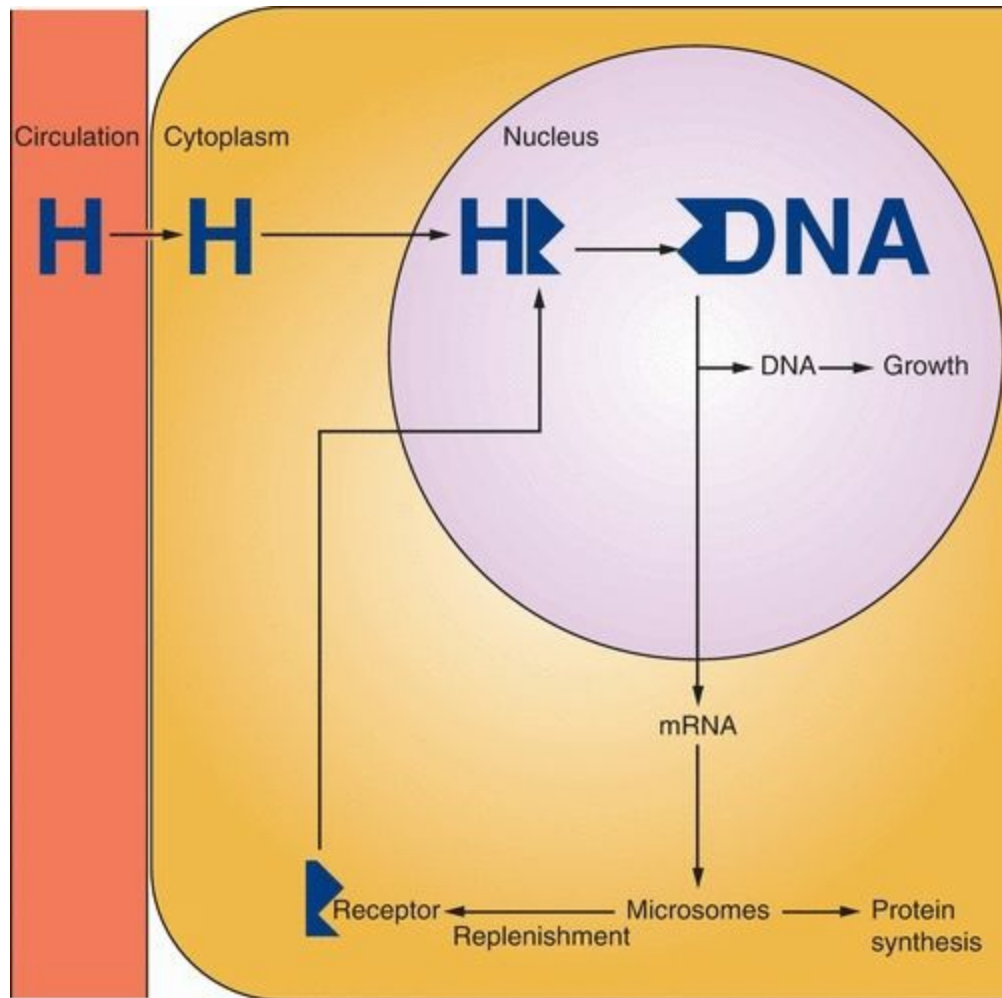
Biologic activity is maintained only while the nuclear site is occupied with the hormone-receptor complex. The dissociation rate of the hormone and its receptor and the half-life of the nuclear chromatin-bound complex are factors in the biologic response because the hormone response elements are abundant and, under normal conditions, are occupied only to a small extent.<sup>39</sup> Thus, an important clinical principle is the following: **duration of exposure to a hormone is as important as dose**. One reason only small amounts of estrogen need be present in the circulation is the long half-life of the estrogen hormone-receptor complex. Indeed, a major factor in the potency differences among the various estrogens (estradiol, estrone, estriol) is the length of time the estrogen-receptor complex occupies the nucleus. The higher rate of dissociation with the weak estrogen (estriol) can be compensated for by continuous application to allow prolonged nuclear binding and activity. Cortisol and progesterone must circulate in large concentrations because their receptor complexes have short half-lives in the nucleus.

An important action of estrogen is the modification of its own and other steroid hormones' activities by affecting receptor concentrations. Estrogen increases target tissue responsiveness to itself and to progestins and androgens by increasing the concentration of its own receptor and that of the intracellular progestin and androgen receptors. Progesterone and clomiphene, on the other hand, limit tissue response to estrogen by blocking this mechanism, thus decreasing over time the concentration of estrogen receptors. Small amounts of receptor depletion and small amounts of steroid in the blood activate the mechanism.

The synthesis of the sex steroid receptors obviously takes place in the cytoplasm, but for estrogen and progestin receptors, synthesis must be quickly followed by transportation into the nucleus. There is an amazingly extensive nuclear traffic.<sup>40</sup> The nuclear membrane contains 3,000–4,000 pores. A cell synthesizing DNA imports about one million histone molecules from the cytoplasm every 3 minutes. If the cell is growing rapidly, about three newly assembled ribosomes will be transported every minute in the other direction. The typical cell can synthesize 10,000–20,000 different proteins. How do they know where to go? The answer is that these proteins have localization signals. In the case of steroid hormone receptor proteins, the signal sequences are in the hinge region.

Estrogen and progestin receptors exit continuously from the nucleus to the cytoplasm and are actively transported back to the nucleus. This is a constant shuttle; diffusion into the cytoplasm is balanced by the active transport into the nucleus. This raises the possibility that some diseases are due to poor traffic control. This can be true of some acquired diseases as well (e.g., Reye syndrome, an acquired disorder of mitochondrial enzyme function).

The fate of the hormone-receptor complex after gene activation is referred to as hormone-receptor **processing** (**Figure 1.14**). In the case of estrogen receptors, processing involves the rapid degradation of receptors unbound with estrogen and a much slower degradation of bound receptors after gene transcription. The rapid turnover of estrogen receptors has clinical significance. The continuous presence of estrogen is an important factor for continuing response.



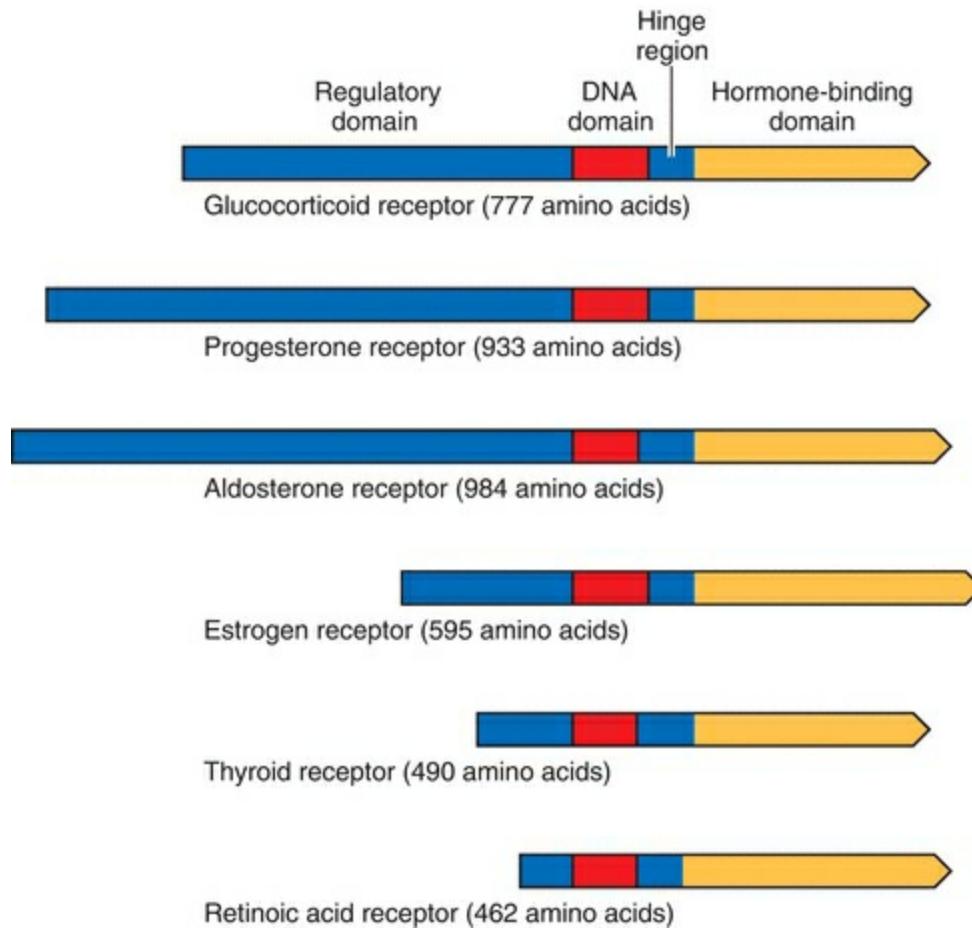
**FIGURE 1.14**

The best example of the importance of these factors is the difference between estradiol and estriol. Estriol has only 20–30% affinity for the estrogen receptor compared with estradiol; therefore, it is rapidly cleared from a cell. But if the effective concentration is kept equivalent to that of estradiol, it can produce a similar biologic response.<sup>41</sup> In pregnancy, where the concentration of estriol is very high, it can be an important hormone, not just a metabolite.

The depletion of estrogen receptors in the endometrium by progestational agents is the fundamental reason for adding progestins to estrogen treatment programs. The progestins accelerate the turnover of preexisting receptors, and this is followed by inhibition of estrogen-induced receptor synthesis. Using monoclonal antibody immunocytochemistry, this action has been pinpointed to the interruption of transcription in estrogen-regulated genes. The mechanism is different for androgen antiestrogen effects. Androgens also decrease estrogen receptors within target tissues, especially in the uterus.<sup>42,43</sup>

# The Nuclear Receptor Superfamily

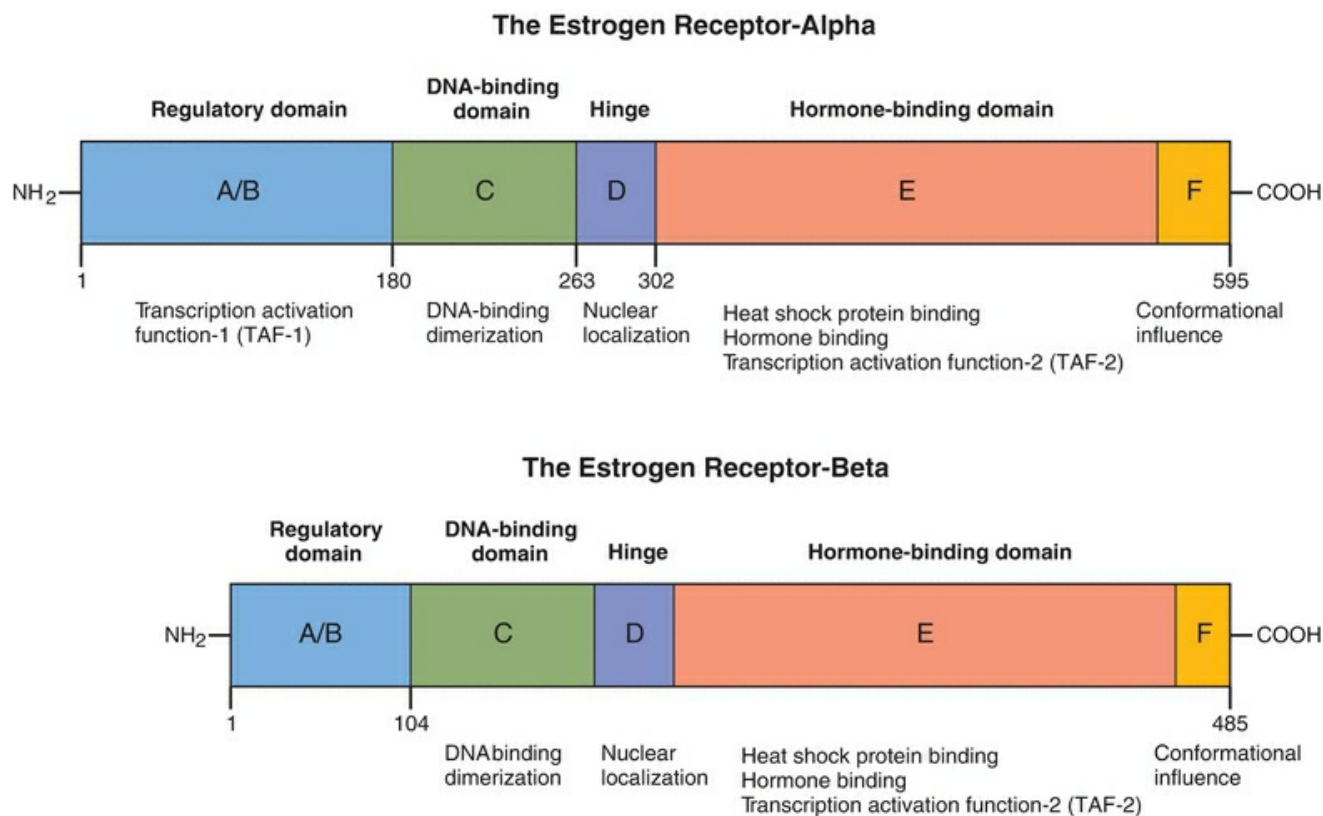
Recombinant DNA techniques have permitted the study of the gene sequences that code for the synthesis of nuclear receptors. Steroid hormone receptors share a common structure with the receptors for thyroid hormone, 1,25-dihydroxyvitamin D<sub>3</sub>, and retinoic acid; thus, these receptors are called a superfamily (**Figure 1.15**).<sup>44,45</sup> Each receptor contains characteristic domains that are similar and interchangeable. Therefore, it is not surprising that the specific hormones can interact with more than one receptor in this family. Analysis of these receptors suggests a complex evolutionary history during which gene duplication and swapping between domains of different origins occurred. This family now includes hundreds of proteins, present in practically all species, from worms to insects to humans. Some are called **orphan receptors** because specific ligands for these proteins have not been identified, but the number of orphan receptors is gradually diminishing (“deorphanization”). It has been convincingly argued that the six steroid receptors originated in a common ancestral receptor gene.<sup>46</sup> The identification of steroid receptors in the sea lamprey dates the origin to over 450 million years ago, and the characterization of a receptor that functions like an estrogen receptor in the mollusk suggests that the ancient and initial sex steroid receptor was an estrogen receptor.<sup>47</sup> Knowledge of the complete human genome has confirmed that there are 48 nuclear receptors in this superfamily.<sup>45</sup>



**FIGURE 1.15**

# The Estrogen Receptors

Two estrogen receptors have been identified, designated as estrogen receptor-alpha (ER- $\alpha$ ) and estrogen receptor-beta (ER- $\beta$ ) (Figure 1.16).<sup>48,49</sup> The estrogen receptor- $\alpha$  was discovered about 1960, and the amino acid sequence was reported in 1986.<sup>50,51,52</sup> The estrogen receptor- $\alpha$  is translated from a 6.8-kilobase mRNA derived from a gene that contains eight exons on the long arm of chromosome 6.<sup>53</sup> It has a molecular weight of approximately 66 kDa with 595 amino acids. The receptor- $\alpha$  half-life is approximately 4–7 hours; thus the estrogen receptor- $\alpha$  is a protein with a rapid turnover. The more recently discovered estrogen receptor- $\beta$ , a protein with 530 amino acids, is encoded by a gene localized to chromosome 14q23.2, in close proximity to genes related to Alzheimer disease.<sup>54,55</sup> Multiple isoforms exist of ER- $\beta$ , including five full-length forms.



**FIGURE 1.16**

Orphan receptors have been identified that are related to the estrogen receptors. They have been designated as estrogen-related receptor (ERR $\alpha$ , ERR $\beta$ , and ERR $\gamma$ ). ERR $\alpha$  may be regulated by coactivator proteins and interacts with typical steroid signaling pathways.<sup>56,57</sup> These orphan receptors are expressed in most tissues and may be

involved in typical estrogen activities, such as the proliferation and differentiation of target cells in the bone and in the breast. Nevertheless, they do not bind estrogens, and no endogenous ligand has been yet identified.

The story is further complicated with the recognition that members of the nuclear receptor superfamily are each associated with multiple isoforms.<sup>58</sup> This increases the number of possible signaling pathways in physiology and disease. In this discussion, we will mention only the most biologically important isoforms.

The estrogen receptors are divided into six regions in five domains, labeled A to F. The ER- $\beta$  is 96% homologous in amino acid sequence with the alpha estrogen receptor in the DNA-binding domain and 60% homologous in the hormone-binding domain. The full comparison is shown in [Table 1.2](#).<sup>54,59,60</sup>

## **TABLE 1.2 Hormone-Binding Domain**

## ER- $\alpha$ and ER- $\beta$ Homology (%)

The regulatory domain	18
The DNA-binding domain	96
The hinge	30
The hormone-binding domain	55
The F region	18

The hormone-binding characteristics of the ER- $\alpha$  and the ER- $\beta$  are similar, indicating that they respond in a comparable manner to the same hormones.<sup>61</sup> Thus, both receptors bind to the estrogen response element with a similar affinity, and the affinity of estradiol for each receptor is similar. There are differences, however; for example, phytoestrogens have a greater affinity for ER- $\beta$  than for ER- $\alpha$ . In other words, estrogenic agents demonstrate preferential binding for one or the other receptor. Different genetic messages can result not only because of differences in binding affinity but also through variations in the mechanisms to be discussed, notably differences in conformational shape and cellular contexts. In addition, because the regulatory domains differ in the two receptors, the ability of ER- $\beta$  to activate gene transcription by means of AF-1 is impaired (discussed below).

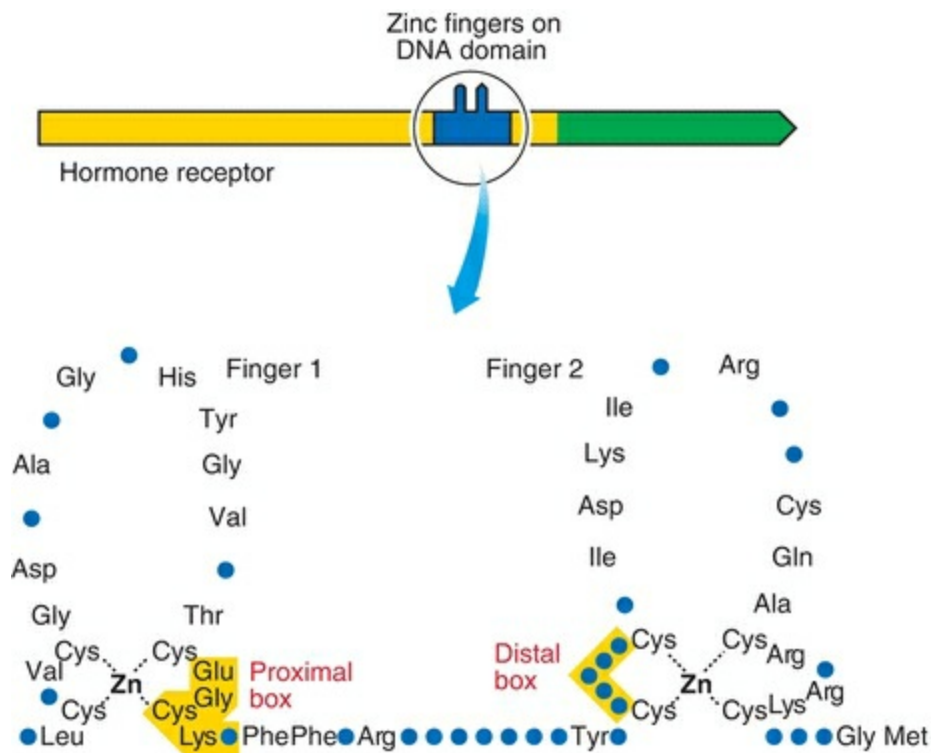
### A/B Region, the Regulatory Domain

The amino acid terminal is the most variable in the superfamily of nuclear receptors, ranging in size from 20 amino acids (in the vitamin D receptor) to 600 amino acids (in the mineralocorticoid receptor). In the ER- $\alpha$ , it contains several phosphorylation sites and the **transcription activation function called AF-1**. AF-1 can stimulate transcription in the absence of hormone binding. The regulatory domain is considerably different in the two estrogen receptors; in ER- $\beta$ , AF-1 is either significantly modified or absent.

### C Region, the DNA-Binding Domain



The middle domain binds to DNA and consists of 100 amino acids with nine cysteines in fixed positions, the two **zinc fingers** (Figure 1.17). This domain is essential for activation of transcription. Hormone binding induces a conformational change in the three helices that allows binding to the hormone-responsive elements in the target gene. This domain is very similar for each member of the steroid and thyroid receptor superfamily; however, the genetic message is specific for the hormone that binds to the hormone-binding domain. The DNA-binding domain controls which gene will be regulated by the receptor and is responsible for target gene specificity and high-affinity DNA binding. The specificity of receptor binding to its hormone-responsive element is determined by the zinc finger region, especially the first finger. The specific message can be changed by changing the amino acids in the base of the fingers. Substitutions of amino acids in the fingertips lead to loss of function. Functional specificity is localized to the second zinc finger in an area designated the d (distal) box. Different responses are due to the different genetic expression of each target cell (i.e., the unique activity of each cell's genetic constitution allows individual behavior).



**FIGURE 1.17**

## D Region, the Hinge

The region between the DNA-binding domain and the hormone-binding domain contains a signal area that is important for the movement of the receptor to the nucleus following

synthesis in the cytoplasm. This nuclear localization signal must be present for the estrogen receptor to remain within the nucleus in the absence of hormone. This region is also a site of rotation (hence the hinge designation) in achieving conformational change.

## **E Region, the Hormone-Binding Domain**

The carboxyl end of the estrogen receptor- $\alpha$  is the hormone-binding domain (for both estrogens and antiestrogens), consisting of 251 amino acids (residues 302–553). It contains 12 helices with a folding pattern that forms a pocket where the hormones bind. The pocket is about 20% smaller in ER- $\beta$ . In addition to hormone binding, this region contains the sites for cofactor binding, is responsible for **dimerization**, and harbors the **transcription activation function called AF-2**. This is also the site for binding by heat shock proteins (specifically hsp 90); when bound, the heat shock proteins prevent dimerization and DNA binding. In contrast to AF-1 activity, AF-2 depends on hormone binding for full activity.

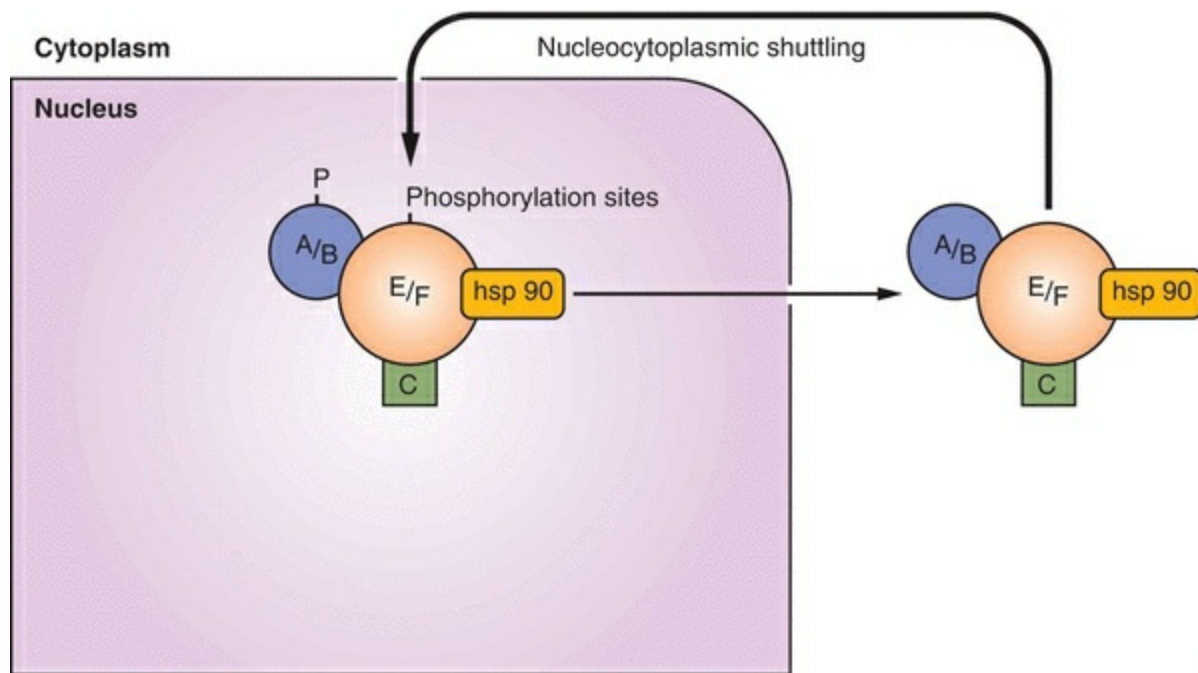
## **F Region**

The F region of ER- $\alpha$  is a 42-amino acid C-terminal segment. This region modulates gene transcription by estrogen and antiestrogens, having a role that influences antiestrogen efficacy in suppressing estrogen-stimulated transcription.<sup>62</sup> The conformation of the receptor-ligand complex is different with estrogen and antiestrogens, and this conformation is different with and without the F region. The F region is not required for transcriptional response to estrogen; however, it affects the magnitude of ligand-bound receptor activity. It is speculated that this region affects conformation in such a way that protein interactions are influenced. Thus, it is appropriate that the effects of the F domain vary according to cell type and protein context. The F region affects the activities of both AF-1 and AF-2, which is what one would expect if the effect is on conformation.<sup>63</sup>

# Estrogen Receptor Mechanism of Action

## Ligand-Dependent Nuclear Activity

The steroid family receptors are predominantly in the nucleus even when not bound to a ligand, except for mineralocorticoid and glucocorticoid receptors (for which nuclear uptake depends on hormone binding). However, the estrogen receptor does undergo what is called **nucleocytoplasmic shuttling** (Figure 1.18). The estrogen receptor can diffuse out of the nucleus and be rapidly transported back in or undergo metabolism. When this shuttling is impaired, receptors are more rapidly degraded. Agents that inhibit dimerization (e.g., the pure estrogen antagonists) prevent nuclear translocation and thus increase cytoplasmic degradation.

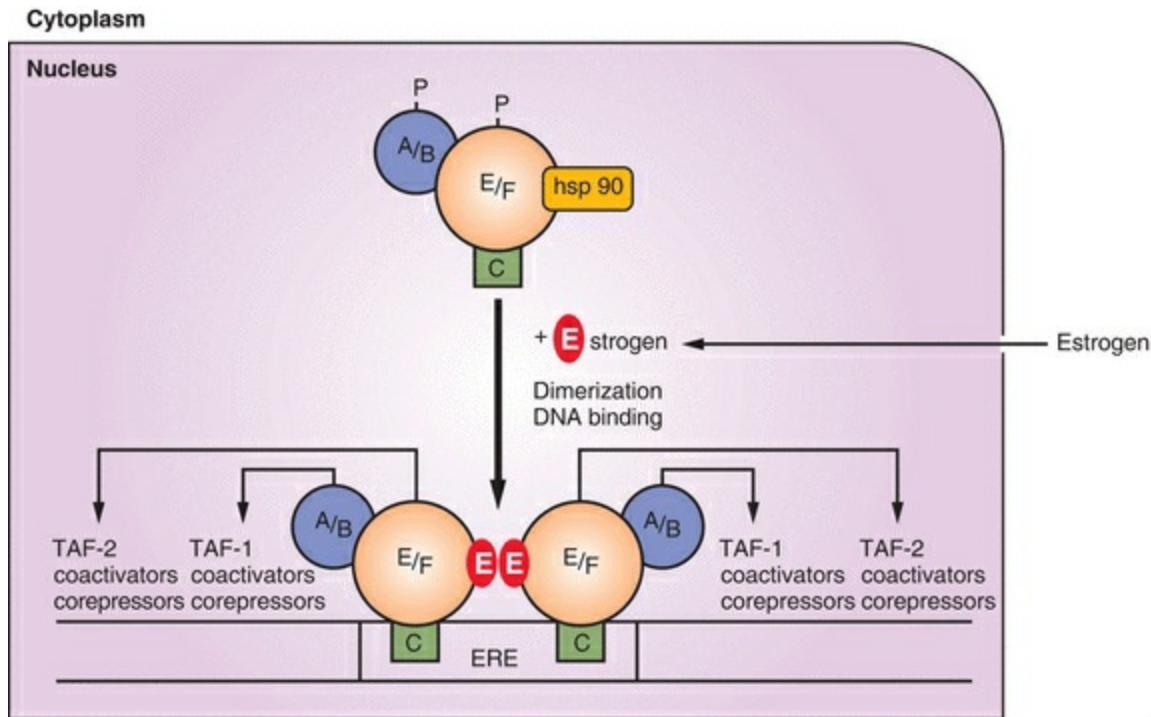


**FIGURE 1.18**

In the absence of estrogen (the ligand), the receptor can become associated with the estrogen response element on a gene, a signal for a process that leads to its proteasome degradation via the ubiquitin pathway.<sup>64</sup> The receptor bound to its ligand, estrogen, undergoes the same process, but at a pace much slower than unliganded receptor, allowing time for gene transcription. This cyclic turnover allows the target cell to be very sensitive to the concentration of the ligand (estrogen) within the cell.

Prior to binding, the estrogen receptor is an inactive complex that includes a variety of chaperone proteins, including the heat shock proteins. Heat shock protein 90 appears

to be a critical protein, and many of the others are associated with it. This heat shock protein is important not only for maintaining an inactive state but also for causing proper folding for transport across membranes. “Activation” or “transformation” occurs with the dissociation of heat shock protein 90<sup>65</sup> (Figure 1.19).



**FIGURE 1.19**

One can imagine the unoccupied steroid receptor as a loosely packed, mobile protein complexed with heat shock proteins. The steroid family of receptors exists in this complex and cannot bind to DNA until union with a steroid hormone liberates the heat shock proteins and allows dimerization. The conformational change induced by hormone binding involves a dissociating process to form a tighter packing of the receptor. The hormone-binding domain contains helices that form a pocket.<sup>66</sup> After binding with a hormone (or with drugs engineered for this purpose), this pocket undergoes a conformational change that creates new surfaces with the potential to interact with coactivator and corepressor proteins. **Conformational shape is an important factor in determining the exact message transmitted to the gene.** Conformational shape is slightly but significantly different with each ligand; estradiol, tamoxifen, and raloxifene each induce a distinct conformation that contributes to the ultimate message of agonism or antagonism.<sup>67,68</sup> Tamoxifen and raloxifene, both AF-2 antagonists, cause a steric repositioning, about a 90-degree rotation, of a helix (the AF-2 helix) that then occupies the binding site of a coactivator in those tissues where such a

coactivator is a requisite for AF-2 activity. The weak estrogen activity of estriol is because of its altered conformational shape when combined with the estrogen receptor in comparison with estradiol.<sup>69</sup>

The hormone-binding domain of the estrogen receptors contains a cavity (the pocket) surrounded by a wedge-shaped structure, and it is the fit into this cavity that is so influential in the final genetic message. The size of this cavity on the estrogen receptor is relatively large, larger than the volume of an estradiol molecule, explaining the acceptance of a large variety of ligands. Thus, estradiol, tamoxifen, and raloxifene each bind in the same cavity within the hormone-binding domain, but the conformational shape with each is not identical.

Conformational shape is a major factor in determining the ability of a ligand and its receptor to interact with coactivators and corepressors. Conformational shapes are not simply either “on” or “off,” but intermediate conformations are possible providing a spectrum of agonist/antagonistic activity. The specific conformational shape of a receptor allows or prevents the recruitment of coactivators and corepressors that ultimately yield various biologic responses.

Members of the thyroid and retinoic acid receptor subfamily do not exist in inactive complexes with heat shock proteins. They can form dimers and bind to response elements in DNA without ligand; in this context, they act as repressors of transcription.

Estrogen receptor mutants can be created that are unable to bind estradiol. These mutants can form dimers with natural estrogen receptor (wild type) and then bind to the estrogen response element, but they cannot activate transcription.<sup>70</sup> This indicates that transcription is dependent on the result after estradiol binding to the estrogen receptor, an estrogen-dependent structural change. Dimerization by itself is not sufficient to lead to transcription; neither is binding of the dimer to DNA sufficient.

Molecular modeling and physical energy calculations indicate that binding of estrogen with its receptor is not a simple key and lock mechanism. It involves conversion of the estrogen-receptor complex to a preferred geometry dictated to a major degree by the specific binding site of the receptor. The estrogenic response depends on the final bound conformation and the electronic properties of functional groups that contribute energy. The final transactivation function is dependent on these variables.

**Estrogen, progesterone, androgen, and glucocorticoid receptors bind to their response elements as dimers, one molecule of hormone to each of the two units in the dimer.** The estrogen receptor- $\alpha$  can form dimers with other  $\alpha$ -receptors (homodimers) or with an estrogen receptor- $\beta$  (heterodimer). Similarly, the estrogen receptor- $\beta$  can form homodimers or heterodimers with the  $\alpha$ -receptor. This creates the potential for many pathways for estrogen signaling, alternatives that are further

increased by the possibility of utilizing various response elements in target genes. Cells that express only one of the estrogen receptors would respond to the homodimers; cells that express both could respond to a homodimer and a heterodimer.

The similar amino acid sequence of the DNA-binding domains in this family of receptors indicates evolutionary conservation of homologous segments. An important part of the conformational pattern consists of multiple cysteine-repeating units found in two structures, each held in a finger-like shape by a zinc ion, the so-called zinc fingers.<sup>71</sup> The zinc fingers on the various hormone receptors are not identical. These fingers of amino acids interact with similar complementary patterns in the DNA. Directed changes (experimental mutations) indicate that conservation of the cysteine residues is necessary for binding activity, as is the utilization of zinc.

The DNA-binding domain is specific for an enhancer site (the hormone-responsive element) in the gene promoter, located in the 5'-flanking region. The activity of the hormone-responsive element requires the presence of the hormone-receptor complex. Thus, this region is the part of the gene to which the DNA-binding domain of the receptor binds. There are at least four different hormone-responsive elements, one for glucocorticoids/progesterone/androgen, one for estrogen, one for vitamin D<sub>3</sub>, and one for thyroid/retinoic acid.<sup>72</sup> These sites significantly differ only in the number of intervening nucleotides.

Binding of the hormone-receptor complex to its hormone-responsive element leads to many changes, only one of which is a conformational alteration in the DNA. Although the hormone-responsive elements for glucocorticoids, progesterone, and androgens mediate all of these hormonal responses, there are subtle differences in the binding sites, and there are additional sequences outside of the DNA-binding sites that influence activation by the three different hormones. The cloning of complementary DNAs for steroid receptors has revealed a large number of similar structures of unknown function. It is believed that the protein products of these sequences are involved in the regulation of transcription initiation that occurs at the TATA box.

There are three different RNA polymerases (designated I, II, and III), each dedicated to the transcription of a different set of genes with specific promoters (the site of polymerase initiation of transcription). **Transcription factors are polypeptides, complexed with the polymerase enzyme, that modulate transcription either at the promoter site or at a sequence further upstream on the DNA.**<sup>73</sup> The steroid hormone receptors, therefore, are transcription factors. The polymerase transcription factor complex can be developed in sequential fashion with recruitment of individual polypeptides, or transcription can result from interaction with a preformed complete complex. The effect can be either positive or negative, activation or repression.

In most cases, therefore, the steroid hormone receptor activates transcription in

partnership with several groups of polypeptides<sup>73</sup>:

1. **Other transcription factors—peptides that interact with the polymerase enzyme and DNA.**
2. **Coactivators and corepressors—peptides that interact with the AF areas of the receptor, also called adaptor proteins or coregulators. Previously considered nuclear proteins, these regulators may also have functions within the cytoplasm.**
3. **Chromatin factors—structural organizational changes that allow an architecture appropriate for transcription response.**

The steroid-receptor complex regulates the amount of mRNA transcripts emanating from target genes. The estrogen-occupied receptor binds to estrogen response elements in the 5'-flanking regions of estrogen-regulated genes, allowing efficient induction of RNA transcription. This can occur by direct binding to DNA and interaction with the estrogen response element or by protein interactions with **coactivators** between the estrogen receptor and DNA sites. **Coactivators and corepressors are intracellular proteins, recruited by hormone receptors, that activate or suppress the AF areas by acting enzymatically either on the receptors or on DNA.**<sup>74,75,76,77,78,79</sup> Most of the genes regulated by estrogens respond within 1–2 hours after estrogen administration. Only a few respond within minutes. This time requirement may reflect the necessity to synthesize regulating proteins.<sup>80</sup> A large number (over 300—a current list is available at [www.nursa.org](http://www.nursa.org)) of coactivator and corepressor proteins have been identified, suggesting that there is a process involved with these proteins, causing selection, activation, queuing, and coordination.<sup>81</sup> In general, corepressor proteins bind to hormone receptors in the absence of a ligand and suppress any basal transcription activity. Active investigation of this step will undoubtedly yield understanding of pathologic responses and new pharmacologic developments because it is already recognized that these proteins influence the phenotypes of human diseases.<sup>82</sup>

Just as coregulators can lead to different responses to the same hormones in different tissues, there is evidence that posttranslational modifications of the coregulators can diversify the regulatory effects.<sup>79,81</sup> The activity of a coregulator protein can be altered by modifications such as phosphorylation or methylation. The response to a specific hormone, therefore, can be complex, differing in various tissues as directed by the coregulators present in that tissue and how the coregulators are modified. The diversity from tissue to tissue is thus very complex, but even within a single cell, impressive diversity is the norm. Because genomic differences among various species are amazingly small (1% or less), evolutionary differences in the way in which genes act, including the complex coregulatory story, make a major contribution

to the phenotypic and behavioral differences in life forms, especially humans. In addition, coregulators provide another evolutionary reservoir that can yield adaptation to new environmental challenges and stresses.

The concentration of coactivators/corepressors can affect the cellular response, and this is another explanation for strong responses from small amounts of hormone. With a small amount of receptor but a large amount of coactivator/corepressor, the cell can be very responsive to a weak signal.

One of the aspects of activation of the estrogen receptor, for example, is an increase in affinity for estrogen. This is an action of estrogen, and it is greatest with estradiol and least with estriol. This action of estradiol, the ability of binding at one site to affect another site, is called **cooperativity**. An increase in affinity is called positive cooperativity. The biologic advantage of positive cooperativity is that this increases the receptor's ability to respond to small changes in the concentration of the hormone. One of the antiestrogen actions of clomiphene is its property of negative cooperativity, the inhibition of the transition from a low-affinity to a high-affinity state. The relatively long duration of action exhibited by estradiol is due to the high-affinity state achieved by the receptor.

AF (activation function) is the part of the receptor that activates gene transcription after binding to DNA. Ligand binding produces a conformational change that allows AFs to accomplish their tasks. AF-1 can stimulate transcription in the absence of hormone when it is fused to DNA; however, it also promotes DNA binding in the intact receptor. AF-2 is affected by the bound ligand, and the estrogen receptor depends on estrogen binding for full activity. AF-2 consists of a number of dispersed elements that are brought together after estrogen binding. The activities of AF-1 and AF-2 vary according to the promoters in target cells. These areas can act independently or with one another. Indeed, the classic estrogen compounds (e.g., estradiol) produce a conformational shape that allows AF-1 and AF-2 to react in a synergistic fashion.

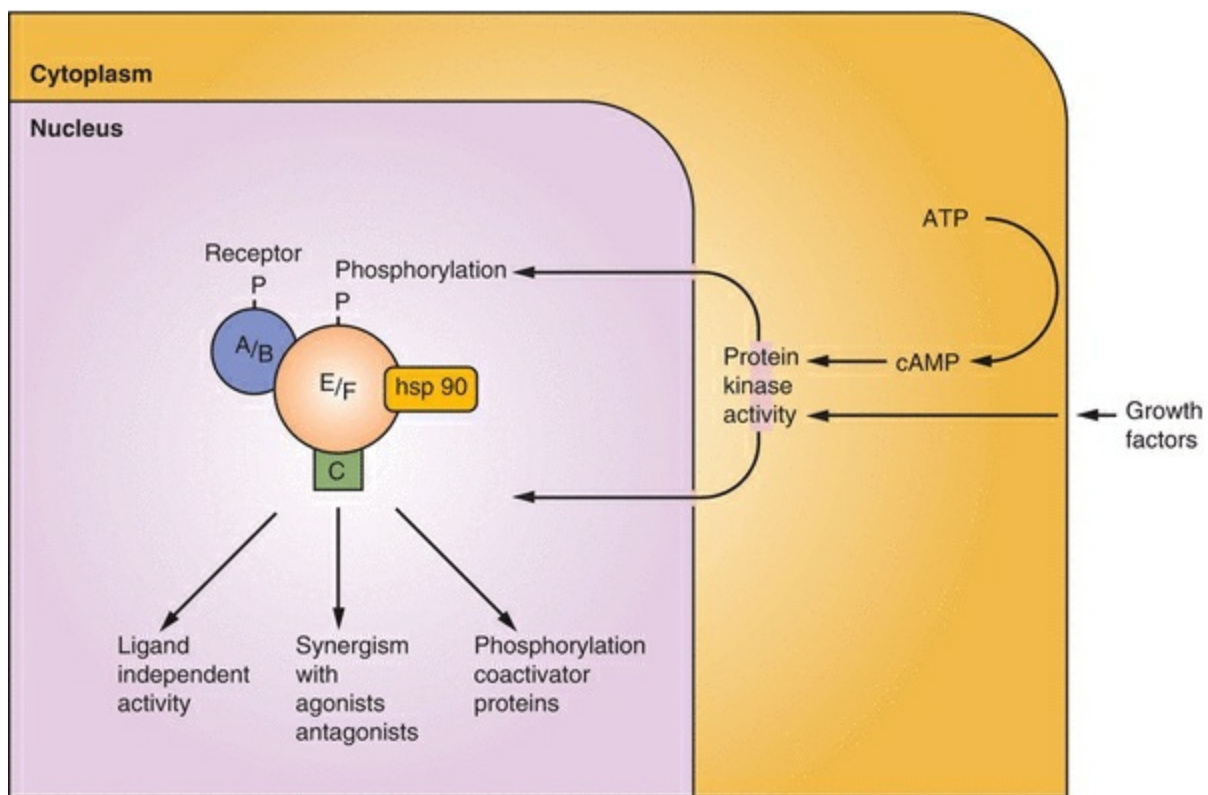
**Thus, the differential activities of the AFs account for different activities in different cells. In addition to the binding of the dimerized steroid receptor to the DNA response element, steroid hormone activity is modulated by other pathways (other protein transcription factors and coactivators/corepressors) that influence transcription activation.<sup>83,84</sup> This concept of cellular context is an important one. The same hormone can produce different responses in different cells according to the cellular context of protein regulators, and responses can be altered by posttranslational modifications of the coregulator proteins.**

## **Ligand-Independent Nuclear Activity**



Phosphorylation of specific receptor sites is an important method of regulation, as well as phosphorylation of other peptides that influence gene transcription. Phosphorylation can be regulated by cell membrane receptors and ligand binding, thus establishing a method for cell membrane-bound ligands to communicate with steroid receptor genes.

Cyclic AMP and protein kinase A pathways increase transcriptional activity of the estrogen receptor by phosphorylation. In some cases, phosphorylation modulates the activity of the receptor; in other cases, the phosphorylation regulates the activity of a specific peptide or coactivator/corepressor that, in turn, modulates the receptor. Phosphorylation follows steroid binding and occurs in both the cytoplasm and nucleus. Thus, phosphorylation enhances activity of the steroid receptor complex (**Figure 1.20**).



**FIGURE 1.20**

Phosphorylation of the receptor increases the potency of the molecule to regulate transcription. Growth factors can stimulate protein kinase phosphorylation that can produce synergistic activation of genes or even ligand-independent activity. Epidermal growth factor (EGF), IGF-I, and transforming growth factor-alpha (TGF- $\alpha$ ) can activate the estrogen receptor in the absence of estrogen, through the AF-1 domain. This response to growth factors can be blocked by pure antiestrogens (suggesting that a strong antagonist locks the receptor in a conformation that resists ligand-independent

pathways). The exact mechanism of growth factor activation is not known, but it is known that a steroid receptor can be activated by means of a chemical signal (a phosphorylation cascade) originating at the plasma membrane. **The recruitment of kinase activity is specific for specific ligands; thus, not all ligands stimulate phosphorylation.**

Another explanation for strong responses from small amounts of steroids is a positive feedback relationship. Estrogen activates its receptor, gene expression stimulates growth factors (EFG, IGF-I, TGF- $\alpha$ , fibroblast growth factor [FGF]), and the growth factors in an autocrine fashion further activate the estrogen receptor.<sup>85</sup> Ligand-independent activation of the estrogen receptor may be an important mechanism where estrogen levels are low, such as in the male.<sup>86</sup>

## Key Points: Steps in the Steroid Hormone Receptor Signaling Mechanism

- Binding of the hormone to the hormone-binding domain that has been kept in an inactive state by various heat shock proteins
- Activation of the hormone-receptor complex, by conformational change, follows the dissociation of the heat shock proteins
- Dimerization of the complex
- Binding of the dimer to the hormone-responsive element on DNA at the zinc finger area of the DNA-binding domain.
- Stimulation of transcription, mediated by activation functions (AFs) and influenced by the protein (other transcription factors and coactivators/corepressors) context of the cell and by phosphorylation

## Key Points: Factors That Determine Biologic Activity

- Affinity of the hormone for the hormone-binding domain of the receptor
- Target tissue differential expression of the receptor subtypes (e.g., ER- $\alpha$  and ER- $\beta$ )
- The concept of conformational shape: the structure of the ligand-receptor complex, with effects on two important activities: dimerization and the recruitment of regulating proteins

- The concept of cellular context: the differential expression of target tissue regulating proteins, coactivators and corepressors and phosphorylation, yielding various biologic responses

## Different Roles for ER- $\alpha$ and ER- $\beta$

Male and female mice have been developed that are homozygous for disruption of the estrogen receptor genes, “estrogen receptor knockout mice.”<sup>59,87,88</sup> Estrogen receptor- $\alpha$ -deficient mice are known as  $\alpha$ ERKO or ERKO mice and ER- $\beta$ -deficient mice as  $\beta$ ERKO or BERKO mice (Table 1.3).<sup>89</sup>

### TABLE 1.3 Characteristics of ERKO and BERKO Mice

**ERKO Mice****BERKO Mice**

Normal life span

Normal life span

Anovulatory

Oligovulatory

Absent breast response at  
pubertyNormal breast glands and  
functionNormal G-U development  
but no adult responseNormal G-U development and  
normal adult responseIncrease in visceral adiposity  
and insulin resistanceNormal body fat distribution and  
insulin secretion

Infertile males and females

Fertile males, subfertile females  
with reduced follicular growth

Spermatogenesis in the  $\alpha$ ERKO male is reduced and the testes undergo progressive atrophy, a result of a testicular role for estrogen, because gonadotropin levels and testicular steroidogenesis remain normal. Sexual mounting behavior is not altered, but intromission, ejaculation, and aggressive behaviors are reduced. Female mice with the alpha estrogen receptor gene disrupted do not ovulate, and the ovaries do not respond to gonadotropin stimulation. These female animals have high levels of estradiol, testosterone, and LH. FSH  $\beta$ -subunit synthesis is increased, but FSH secretion is at normal levels, indicating different sites of action for estrogen and inhibin. Uterine development is normal (due to a lack of testosterone in early life), but growth is impaired. Mammary gland ductal and alveolar development is absent. Female mice with absent alpha estrogen receptor activity do not display sexual receptive behaviors. This genetically engineered line of mice demonstrates essential activities for the alpha estrogen receptor. Relatively normal fetal and early development suggests that the beta estrogen receptor plays a primary role in these functions. For example, the fetal adrenal gland expresses high levels of ER- $\beta$  and low levels of ER- $\alpha$ .<sup>90</sup> However, nongenomic

actions of estrogen are also possible and can explain some of the estrogenic responses in a knockout model. The results from estrogen receptor knockout mice as well as mice with disruption of the aromatase enzyme indicate that estrogen is essential for fertility, but not for the development of the reproductive tract or for survival.<sup>91</sup>

These genetic mice experiments also highlight the importance of estrogen in preventing the development of the metabolic syndrome. Knockout models for the estrogen receptors as well as the knockout model for the aromatase enzyme yield mice with hyperinsulinemia and increased visceral adiposity, with a reversal achieved by estrogen treatment.<sup>19</sup>

Differential expression of the  $\alpha$ - and  $\beta$ -receptors is present in various tissues (e.g., ER- $\beta$  is the prevalent estrogen receptor in certain areas of the brain and the cardiovascular system) resulting in different and selective responses to specific estrogens.<sup>88,92,93</sup> Human granulosa cells from the ovarian follicle contain only ER- $\beta$  mRNA; the human breast expresses both ER- $\alpha$  and ER- $\beta$ , but ER- $\alpha$  is primarily involved in mammary development and function. Some parts of the rat brain contain only ER- $\beta$ , others only ER- $\alpha$ , and some areas contain both receptors.<sup>94</sup> Target tissues that have been classically regarded as estrogen-sensitive (such as the uterus and the breast) express mainly ER- $\alpha$ . But, the knockout models have oversimplified the roles of ER- $\alpha$  and ER- $\beta$ , at least in breast tissue; their roles are dynamic and changing, not a simple expression of always one or the other.

Two commonly used estrogens, 17 $\beta$ -estradiol and ethinyl estradiol (the estrogen component of steroid contraceptives), bind equally well to the alpha and beta estrogen receptors. However, ER- $\beta$  plays a lesser role in those target tissues affected by these two estrogens, specifically the uterus, breast, bone, hypothalamus, and pituitary.

ER- $\beta$  may have a regulatory role. In some tissues, ER- $\beta$  reduces ER- $\alpha$ -regulated gene transcription, even though in the absence of ER- $\alpha$ , ER- $\beta$  can function as an estrogen receptor.<sup>95</sup> ER- $\beta$  acts as a natural suppressor of estrogen (ER- $\alpha$ ) activity in breast tissue, and decreased concentrations of ER- $\beta$  are associated with more aggressive tumors and reduced sensitivity to tamoxifen.<sup>96,97</sup> The colon contains only ER- $\beta$ , and the reduction in the risk of colonic cancer associated with postmenopausal estrogen therapy may reflect an antiproliferative activity of the  $\beta$ -receptor. Decreases in ER- $\beta$  expression have been observed in cancers occurring in the endometrium, ovary, colon, and prostate.<sup>98</sup>

The estrogen story is further complicated by the fact that the same estrogen binding to the  $\alpha$ - and  $\beta$ -receptors can produce opposite effects. For example, estradiol can stimulate gene transcription with ER- $\alpha$  at a given site of the estrogen response element, whereas estradiol inhibits gene transcription with ER- $\beta$  in this same system.<sup>99</sup> In other

tissues, the opposite scenario can occur with estradiol increasing ER- $\beta$  expression. Different and unique messages, therefore, can be determined by the specific combination of (1) a particular estrogen, (2) the  $\alpha$ - or  $\beta$ -receptor, and (3) the targeted response element. **To some degree, differences with ER- $\alpha$  and ER- $\beta$  are influenced by activation of AF-1 and AF-2; agents that are capable of mixed estrogen agonism and antagonism produce agonistic messages via AF-1 with ER- $\alpha$ , but because ER- $\beta$  lacks a similar AF-1, such agents can be pure antagonists in cells that respond only to ER- $\beta$ .**<sup>97</sup> ER- $\alpha$  and ER- $\beta$  affect the peptide context of a cell, especially coactivators and corepressors, differently. At least one component of this differing behavior is the fact that the two receptors do not bind to DNA in the same exact site, and the locations have different properties that could account for some of the differences in effects produced by each receptor; specifically, the two receptors can each activate regions of a gene, but some regions selectively respond to one or the other.<sup>100</sup>

# Ligand-Cell Membrane Extranuclear Receptor Activity

Not all actions of estrogen, and presumably all steroid hormones, are genomic, requiring gene transcription. Rapid cellular responses after estrogen stimulation are initiated by estrogen binding at the level of the cell membrane. These responses are traditionally associated with growth factors and G-protein-coupled receptors. However, it is not appropriate to designate this activity as “nongenomic” because the cell membrane estrogen-induced signaling leads to both gene transcription and to events independent of transcription. This extranuclear pathway activates various protein kinases that can cause ion fluxes of calcium and potassium, modification of second messenger systems, and indirect effects on growth factors, transcription factors, and genetic promoters.<sup>101</sup> A good example of membrane-associated estrogen activity is the stimulation of endothelial nitric oxide synthase.<sup>102</sup> Putative membrane receptors have been reported to be both related to ER- $\alpha$  and different from the estrogen receptor. The expression of a truncated isoform of ER- $\alpha$  involved in acute activation of nitric oxide has been described in the caveoli of human vascular endothelial cells.<sup>103</sup> A G-protein-coupled receptor localized to the endoplasmic reticulum has been identified that binds estrogen and affects intracellular functions.<sup>104</sup>



# Ligand-Dependent, ERE-Independent Activity

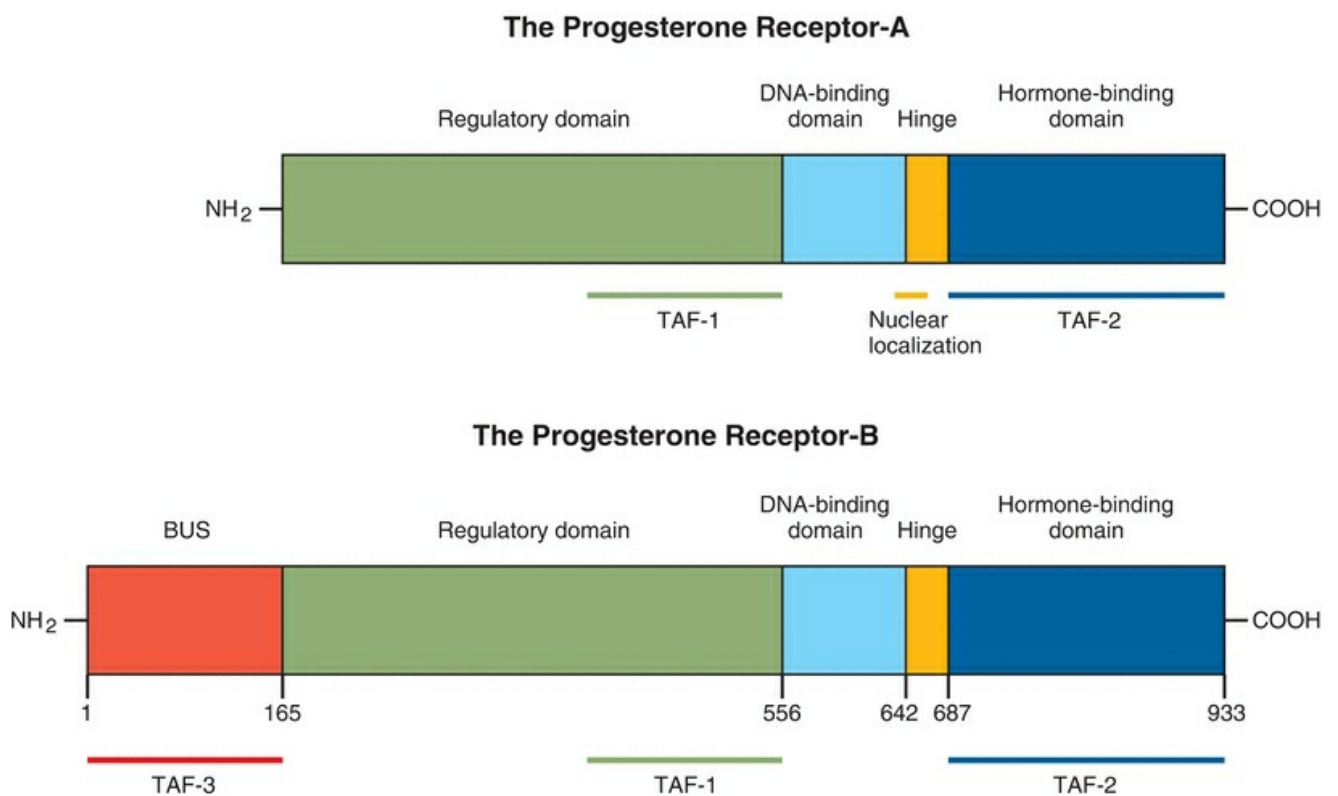
We have described three pathways that mediate estrogen activity:

- 1. Ligand-dependent nuclear activity: the classical mechanism involving the estrogen receptors with binding to DNA estrogen response elements**
- 2. Ligand-independent nuclear activity: activation of the estrogen receptor pathway through second messengers, involving phosphorylation of estrogen receptors and coregulator proteins**
- 3. Ligand-cell membrane extranuclear receptor activity: rapid responses mediated by estrogen receptors in cell membranes**

There is at least one more pathway, evident from studies with mutant mice: the ligand-dependent, ERE-independent nuclear pathway.<sup>105</sup> In these animals, mutant forms of the estrogen receptor cannot bind to ERE, the estrogen response element in DNA, and yet some physiologic actions of estrogen can be demonstrated, such as negative feedback inhibition of LH secretion, indicating hormonal mediation of a cellular response, but not through the classical pathway.

# The Progesterone Receptor

The progesterone receptor is induced by estrogens at the transcriptional level and decreased by progestins at both the transcriptional and translational levels (probably through receptor phosphorylation).<sup>106,107</sup> The progesterone receptor (in a fashion similar to the estrogen receptor) has three major forms, designated the A, B, and C receptors, of which A and B are most relevant to progesterone signaling. The C receptor is the smallest and lacks the ability to initiate transcription, and may even function in some tissues as an inhibitor of the B receptor (**Figure 1.21**).<sup>108</sup> The three isoforms are expressed by a single gene on chromosome 11 at q22–23; the three forms are a consequence of transcription from distinctly different promoters, in a complex system of transcription regulation.<sup>109</sup> Each form is associated with additional proteins, which are important for folding of the polypeptide into a structure that allows hormone binding and receptor activity.<sup>110</sup> The molecular weight of PR-A is 94 kDa, while PR-B's molecular weight is 114 kDa, containing 933 amino acids (164 more than PR-A). The B receptor has a unique upstream segment (128–165 amino acids, depending on the species) referred to as the B-upstream segment (BUS).



**FIGURE 1.21**

On the progesterone receptor, AF-1 is located in a 91-amino acid segment just upstream of the DNA-binding domain. AF-2 is located in the hormone-binding domain. A fragment missing the hormone-binding domain activates transcription to levels comparable to full-length hormone-activated B receptors, and higher than that with the A receptor, thus beyond that of AF-1 alone. In appropriate cells, therefore, BUS contains a third activation domain, AF-3, and can autonomously activate transcription, or it can synergize with the other AFs.<sup>111</sup> In the absence of hormone binding, the C-terminal region of the progesterone receptor exerts an inhibitory effect on transcription.<sup>112</sup> Progesterone agonists induce a conformational change that overcomes the inherent inhibitory function within the carboxy tail of the receptor. Binding with a progesterone antagonist produces a structural change that allows the inhibitory actions to be maintained.

Progestational agents can elicit a variety of responses determined by target tissue production and activity of the two receptor forms with dimerization as AA and BB (homodimers) or AB (heterodimer). The progesterone receptors function in the mechanism shared by this superfamily of receptors: an unbound complex with heat shock proteins, hormone binding, dimerization, DNA binding to a progesterone response element, and modulation of transcription by phosphorylation and various proteins.<sup>68,113</sup>

PR-A and PR-B are expressed in varying amounts in breast cancer and endometrial cancer cell lines. Studies indicate that the two receptors can be regulated independently; for example, the relative levels differ in the endometrium during the menstrual cycle.<sup>114</sup> Tissue specificity with the progesterone receptor is influenced by which receptor and which dimer is active; in addition, the transcriptional activities of PR-A and PR-B depend on target cell differences, especially in promoter context. **However, in most cells, PR-B is the positive regulator of progesterone-responsive genes, and PR-A inhibits PR-B activity.** Mutations within the carboxy terminus of PR-B affect its transcriptional activity. But mutations in PR-A have no effect on its transcriptional inhibitory activity. This indicates two separate pathways for transcription activation and repression by the progesterone receptor. Thus, repression of human estrogen receptor transcriptional activity (as well as glucocorticoid, mineralocorticoid, and androgen transcription) is dependent on the expression of PR-A.<sup>115,116</sup> The A and B progesterone receptors have different molecular functions, affecting different genes, and, therefore, target tissue response to progesterone will be influenced by the differential expression of each receptor and the ratio of their concentrations, as well as the target tissue context of adaptor proteins.<sup>117,118</sup>

The broad activity of PR-A in regard to all steroids suggests that it regulates inhibition of steroid hormone action wherever it is expressed. PR-A does not form a heterodimer with the estrogen receptor, nor does it prevent the estrogen receptor from

binding with DNA. PR-A does not change the structure of the estrogen receptor. Therefore, either PR-A competes with the estrogen receptor for a critical protein (in this case, PR-A would inhibit the estrogen receptor only in cells that contain the critical factor), or the target is a critical protein, again an essential transcription activator.<sup>110,114</sup>

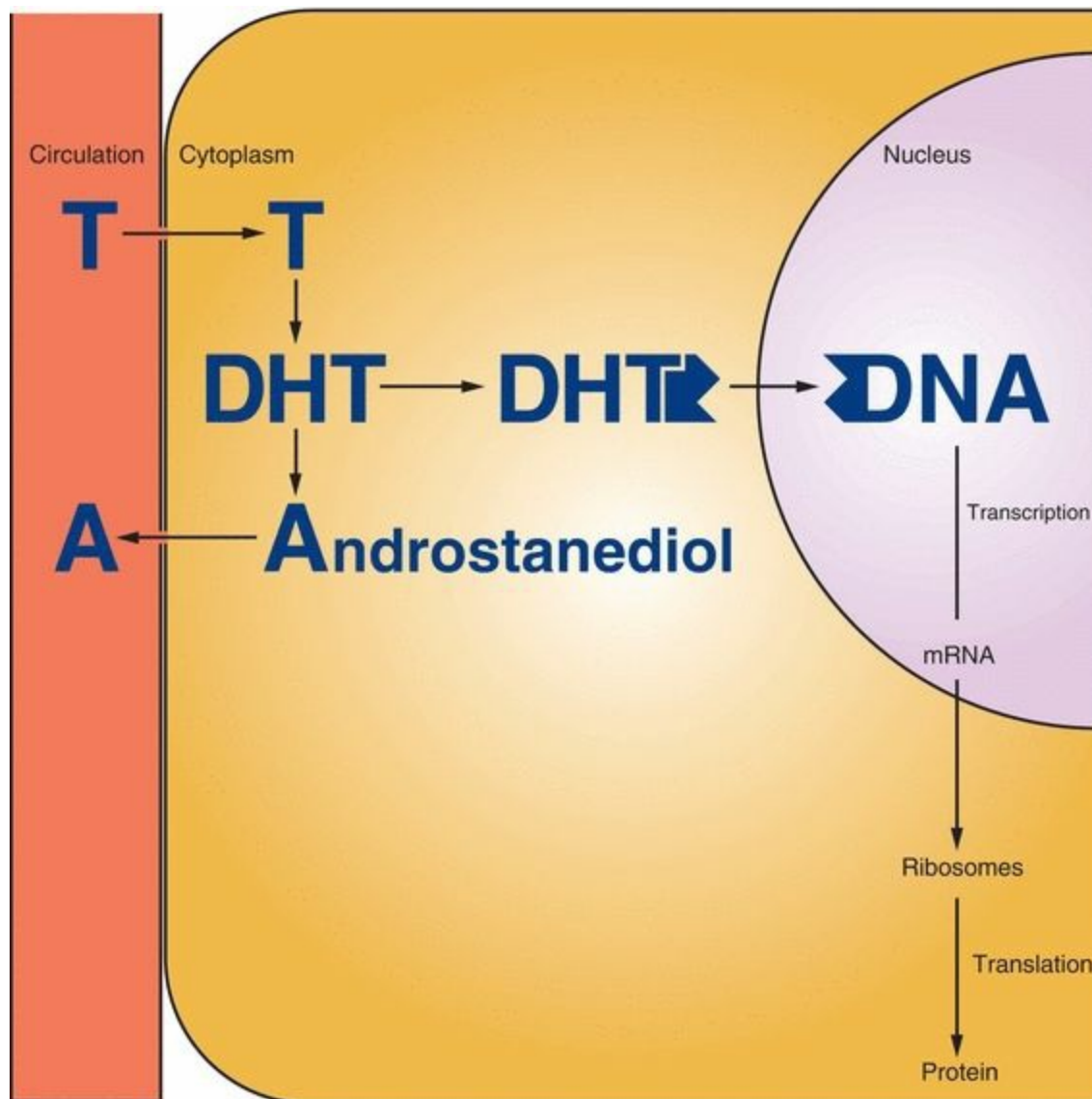
Progesterone shares with estrogen (and probably all steroid hormones) the ability to exert activity at the cell membrane, independently of the progesterone receptor.<sup>119</sup> For example, progesterone or a progesterone metabolite can prevent uterine contractions by binding to the oxytocin G protein receptor in the cell membrane and inhibiting its function.<sup>120</sup>

PRKO mice (lacking both progesterone receptors A and B) are unable to ovulate due to a failure to expel a mature oocyte in a fully developed follicle, specifically a failure in the LH-induced rupture of a follicle.<sup>121</sup> When only PR-A is deficient, ovulation is severely impaired, but not totally reduced, indicating that both receptors contribute to ovulation, but PR-A is essential for normal function.

Like estrogen, G-protein-coupled receptors for progesterone have been identified, providing a pathway for progesterone activation of various signaling cascades involved in cellular functions, including gene expression.<sup>122</sup> A role for a membrane receptor has been proposed for progesterone's antiapoptotic actions in ovarian granulosa cells.<sup>123</sup>

# The Androgen Receptor

The cellular mechanism is more complex for androgens (**Figure 1.22**). Androgens can work in any one of three ways:



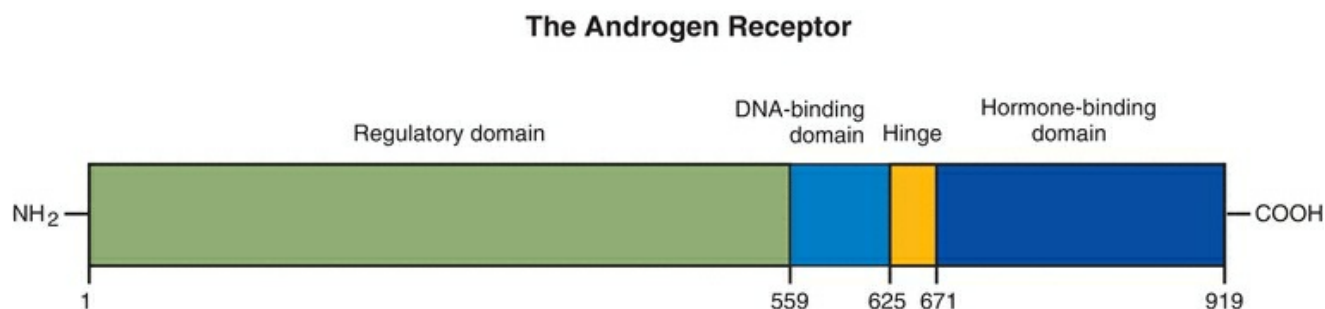
**FIGURE 1.22**

1. By intracellular conversion of testosterone to dihydrotestosterone (DHT), intracrine activity
2. By testosterone itself, endocrine activity
3. By intracellular conversion of testosterone to estradiol (aromatization), intracrine activity

Tissues that exclusively operate via the testosterone pathway are the derivatives of the Wolffian duct, whereas hair follicles and derivatives of the urogenital sinus and urogenital tubercle require the conversion of testosterone to DHT. The hypothalamus actively converts androgens to estrogens; hence, aromatization may be necessary for certain androgen feedback messages in the brain.

In those cells that respond only to DHT, only DHT will be found within the nucleus activating messenger RNA production. Because testosterone and DHT bind to the same high-affinity androgen receptor, why is it necessary to have the DHT mechanism? One explanation is that this is a mechanism for amplifying androgen action, because the androgen receptor preferentially will bind DHT (greater affinity). The antiandrogens, including cyproterone acetate and spironolactone, bind to the androgen receptor with about 20% of the affinity of testosterone.<sup>124</sup> This weak affinity is characteristic of binding without activation of the biologic response.

The androgen receptor, like the progesterone receptor, exists as the full-length B form and a shorter A form (**Figure 1.23**).<sup>125</sup> It is likely that the A and B forms of the androgen receptor have functional differences. The amino acid sequence of the androgen receptor in the DNA-binding domain resembles that of the receptors for progesterone, mineralocorticoids, and glucocorticoids but most closely that of the progesterone receptor.<sup>126</sup> Androgens and progestins can cross-react for their receptors but do so only when present in pharmacologic concentrations. Progestins compete not only for androgen receptors but also for the metabolic utilization of the 5 $\alpha$ -reductase enzyme. The dihydroprogesterone that is produced, in turn, also competes with testosterone and DHT for the androgen receptor. A progestin, therefore, can act both as an antiandrogen and as an antiestrogen. Androgen-responsive gene expression can also be modified by estrogen; it has been known for years that androgens and estrogens can counteract each other's biologic responses. These responses of target tissues are determined by gene interactions with the hormone-receptor complexes, androgen with its receptor, and estrogen with its receptor. The ultimate biologic response reflects the balance of actions of the different hormones with their respective receptors, modified by various transcription regulators.



## FIGURE 1.23

The syndrome of androgen insensitivity represents a congenital abnormality in the androgen intracellular receptor (with several hundred identified unique mutations)<sup>127,128</sup> The androgen receptor gene is localized on the human X chromosome at Xq12, the only steroid hormone receptor to be located on the X chromosome.<sup>129</sup> Thus, androgen insensitivity is an X-linked disorder. The genotype-phenotype correlation can be conceptualized as a progressive increase in androgen receptor action. At one end, there is a complete absence of androgen binding—complete androgen insensitivity. In the middle is a spectrum of clinical presentations representing varying degrees of abnormal receptors and binding. At the other end, about 25% of infertile men with normal genitalia and normal family histories have azoospermia due to an androgen receptor disorder.<sup>130,131</sup> The androgen receptor also plays a role in motor neuron physiology, because a specific mutation in the androgen receptor is responsible for Kennedy disease (X-linked spinobulbar muscular atrophy), a condition associated with motor neuron degeneration.<sup>132</sup>

# STEROID HORMONE RECEPTOR ANTAGONISTS

---

While agonists are substances that stimulate a response when bound to a receptor, antagonists inhibit the actions of an agonist. Antagonistic activity is characterized by blockage of the receptor message or nontransmission of the message. Most compounds used in this fashion that bind to hormone nuclear receptors have a mix of agonist and antagonist responses, depending on the tissue and hormonal milieu. Examples of antagonists include tamoxifen, mifepristone (RU-486), and androgen receptor antagonists.



## **Short-Acting Antagonists**

Short-acting antagonists, such as estriol, are actually a mixed combination of agonism and antagonism depending on time. Short-term estrogen responses can be elicited because estriol binds to the nuclear receptor, but long-term responses do not occur because this binding is short-lived. Antagonism results when estriol competes with estradiol for receptors. However, if a constant presence of the weak hormone, estriol, can be maintained, then long-term occupation is possible, and a potent estrogen response can be produced.

# **Long-Acting Antagonists**

Clomiphene and tamoxifen are mixed estrogen agonists and antagonists. The endometrium is very sensitive to the agonistic response, whereas the breast is more sensitive to the antagonistic behavior. The antagonistic action is the result of nuclear receptor binding with an alteration in normal receptor-DNA processing and eventual depletion of hormone receptors.

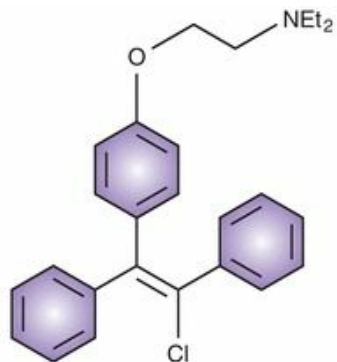
# Physiologic Antagonists

Strictly speaking, a progestin is not an estrogen antagonist. It modifies estrogen action by causing a depletion of estrogen receptors. There is also evidence that a progestin can inhibit transcription activation by the estrogen receptor.<sup>133</sup> In addition, progestins induce enzyme activity that converts the potent estradiol to the impotent estrone sulfate, which is then secreted from the cell.<sup>134</sup> Androgens block the actions of estrogen, also by depleting target tissues of estrogen receptors.

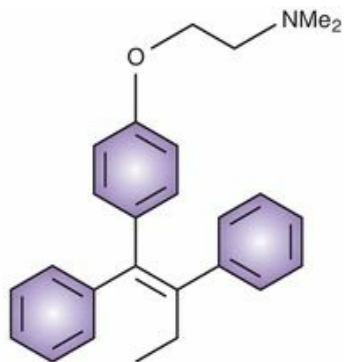
# Antiestrogens

Currently, there are two groups of antiestrogens: pure antiestrogens and compounds with both agonistic and antagonistic activities ([Figure 1.24](#)). The mixed agonist-antagonist compounds include both the triphenylethylene derivatives (the nonsteroidal estrogen relatives such as clomiphene and tamoxifen) and the nonsteroidal sulfur-containing agents (the benzothiophenes, such as raloxifene). The pure antiestrogens have a bulky side chain that, with only a little imagination, can be pictured as an obstruction to appropriate conformational changes. **An ideal antiestrogen would have the following properties:**

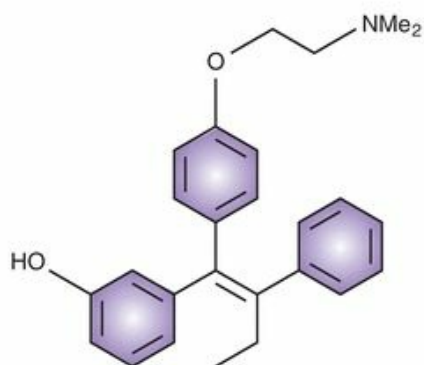
Triphenylethylene derivatives



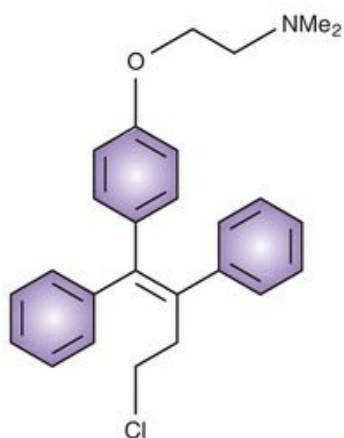
Clomiphene



Tamoxifen

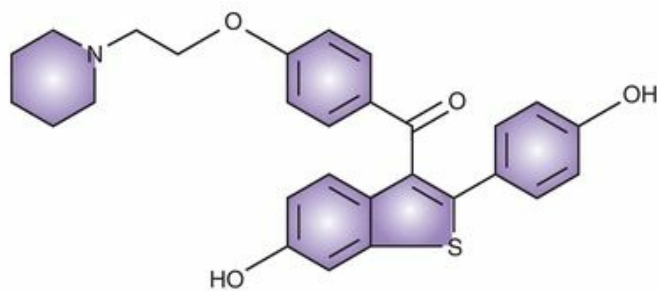


Droloxifene



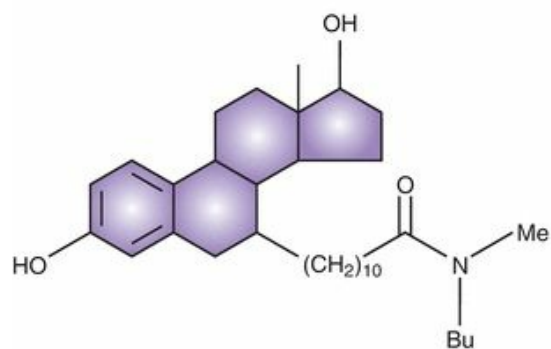
Toremifene

Benzothiphene derivative

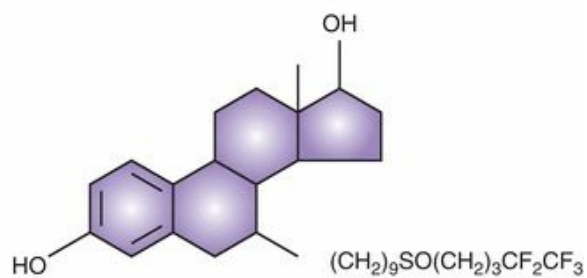


Raloxifene

Pure antiestrogens



ICI 164,384



Fulvestrant  
(ICI 182,780)

## FIGURE 1.24

1. A compound that would be a pure antagonist on proliferating breast carcinoma cells.
2. Development of resistance would be rare or require long exposure.
3. High affinity for the estrogen receptor so that therapeutic doses could be easily achieved.
4. No interference with the beneficial actions of estrogens.
5. No toxic or carcinogenic effects.

### The Antiestrogen Tamoxifen

Tamoxifen is very similar to clomiphene (in structure and actions), both being nonsteroidal compounds structurally related to diethylstilbestrol. Tamoxifen, in binding to the estrogen receptor, competitively inhibits estrogen binding. In vitro, the estrogen-binding affinity for its receptor is 100–1,000 times greater than that of tamoxifen. Thus, tamoxifen must be present in a concentration 100–1,000 times greater than estrogen to maintain inhibition of breast cancer cells. In vitro studies demonstrated that this action was not cytotoxic, but, rather, cytostatic (and thus, its use must be long term). The tamoxifen-estrogen receptor complex binds to DNA, but whether an agonistic, estrogenic message or an antagonistic, antiestrogenic message predominates is determined by what promoter elements (coactivators) are present in specific cell types. If the mechanism is cytostatic, why does a treatment period of 5 years provide protection against recurrent disease for at least 10 years? It has been suggested that exposure to tamoxifen sensitizes cells to the apoptotic effects of a woman's own estrogen levels.<sup>135,136</sup>

There have been many clinical trials with adjuvant treatment of breast cancer with tamoxifen, and many are still ongoing.<sup>137,138,139</sup> Overall, the impact of tamoxifen treatment on breast cancer can be summarized as follows: disease-free survival is prolonged. There is an increased survival after 5 years of treatment and 10 years of follow-up of approximately 26%, most evident in women over age 50. Response rates in advanced breast cancer are 30–35%, most marked in patients with tumors that are positive for estrogen receptors, reaching 75% in tumors highly positive for estrogen receptors.

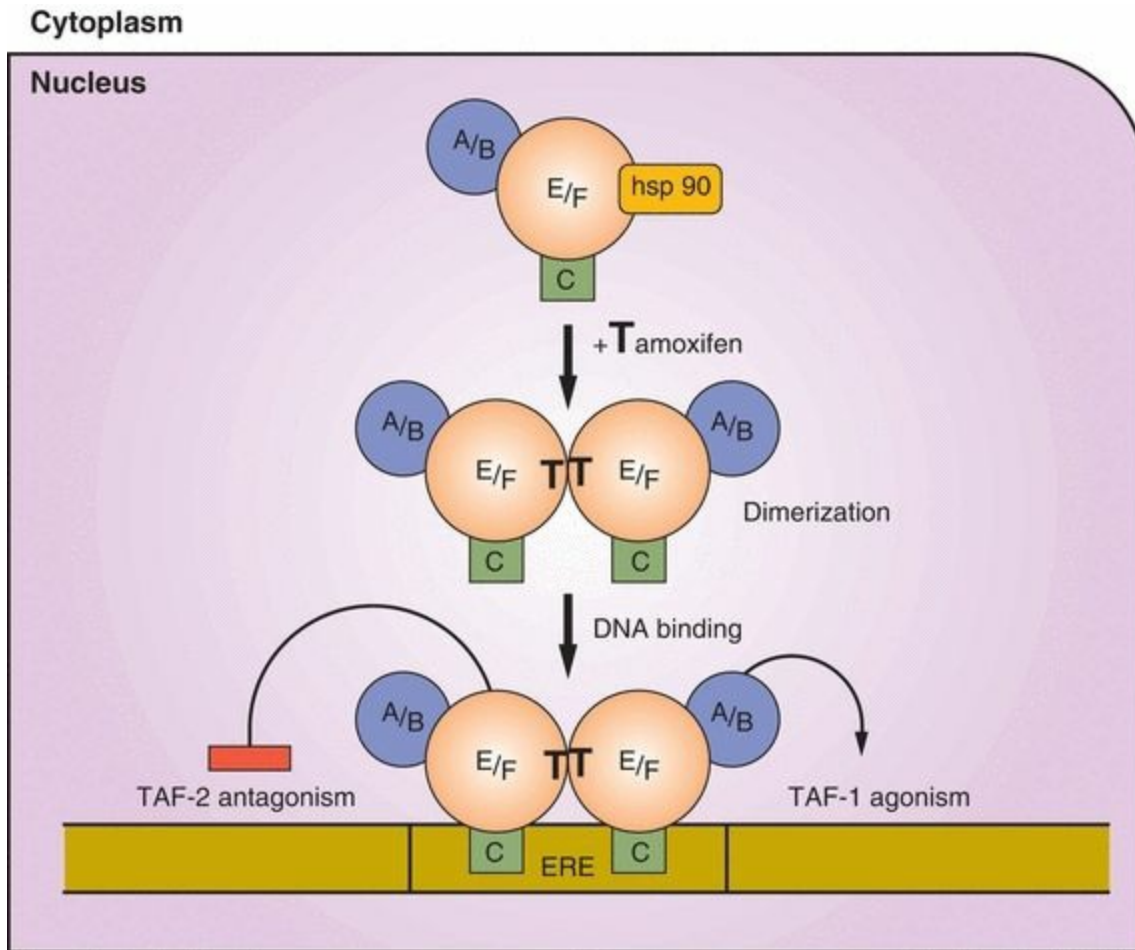
Serum protein changes reflect the estrogenic (agonistic) action of tamoxifen. This includes decreases in antithrombin III, cholesterol, and LDL cholesterol, while SHBG levels increase (as do other binding globulins). The estrogenic activity of tamoxifen (when taken as 20 mg daily) is nearly as potent as 2 mg estradiol in lowering FSH

levels in postmenopausal women, 26% versus 34% with estradiol.<sup>140</sup> The estrogenic actions of tamoxifen include the stimulation of progesterone receptor synthesis, an estrogen-like maintenance of bone, and estrogenic effects on the vaginal mucosa and the endometrium. Tamoxifen causes a decrease in antithrombin III, and there has been a small increase in the incidence of venous thromboembolism observed in tamoxifen-treated patients compared with controls.<sup>141,142,143</sup>

All too often, the antagonistic, antiestrogenic action of tamoxifen is featured, and the estrogenic, agonistic action is ignored. There is about a fourfold increase in endometrial cancer occurring in women receiving tamoxifen treatment.<sup>143,144,145</sup> In addition, tamoxifen has been associated with major flare-ups in endometriosis. Tamoxifen, therefore, has a variety of side effects that indicate both estrogenic activity and antiestrogenic activity. How can tamoxifen be both an estrogen agonist and an estrogen antagonist?

## **Tamoxifen Mechanism of Action**

AF-1 and AF-2 areas can both activate transcription, but AF-2 activates transcription only when it is bound by estrogen. The individual transactivating abilities of AF-1 and AF-2 depend on the promoter and cell context. Tamoxifen's agonistic ability is due to activation of AF-1; its antagonistic activity is due to competitive inhibition of the estrogen-dependent activation of AF-2 (**Figure 1.25**).



**FIGURE 1.25**

An estrogen-associated protein, a coactivator, binds to the right-hand side of AF-2. Estrogen binding induces binding of this protein, which then activates transcription. This protein recognizes only an activated conformation of the estrogen receptor, the result of estrogen binding. Tamoxifen binding to the AF-2 area does not activate this domain because, in at least one explanation, the conformational change does not allow binding of the estrogen-associated protein, the activating factor.<sup>74,146</sup> Antagonism of AF-2 activity is further enhanced by the recruitment of corepressors after tamoxifen binds to the hormone-binding domain.<sup>84</sup>

The activity of AF-2 is negligible in the presence of tamoxifen. In cells where AF-1 and AF-2 function independently of each other, tamoxifen would be chiefly an antagonist in cells where AF-2 predominates and an agonist where AF-1 predominates, and in some cells, a mixed activity is possible.<sup>147</sup>

The contact sites of estrogens and antiestrogens with the estrogen receptor are not identical.<sup>148</sup> When an antiestrogen binds to the estrogen receptor, the conformational changes that are induced alter the ability of the estrogen receptor-antiestrogen complex



to modulate transcriptional activity. The relative agonist-antagonist activity is determined by the specific conformation achieved by the specific antiestrogen.

Even though tamoxifen can block estrogen-stimulated transcription of many genes, its degree of antagonistic activity varies among different animals, different cell types, and different promoters within single cells. These differences are due to differences in the relative activities of the AFs. Thus, the extent to which an antiestrogen inhibits an estrogen-mediated response depends on the degree to which that response is mediated by AF-2 activity as opposed to AF-1 activity, or mixed activity.<sup>149</sup> In some cell lines, AF-1 is dominant; in others, both are necessary. No cells have yet been identified where AF-2 is dominant.

In most cell types, AF-1 is too weak to activate transcription by itself, but, of course, there are well-known exceptions: endometrium, bone, and liver. In these tissues, the promoter context is right. Tamoxifen is a significant activator of estrogen receptor-mediated induction of promoters that are regulated by the AF-1 site.

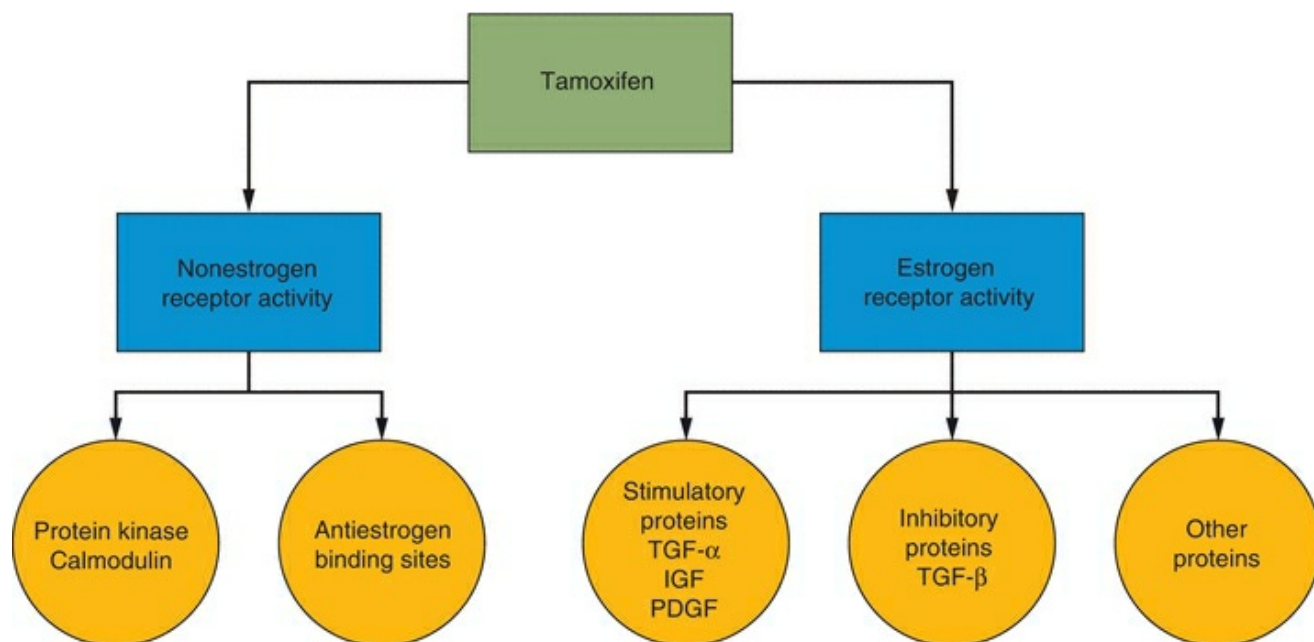
## Key Points

The response of cells to estrogens and antiestrogens depends on:

- **The nature of the estrogen receptor**
- **The estrogen response elements and nearby promoters**
- **The cell context of protein coactivators and corepressors**
- **The properties of the ligand**
- **Modulation by growth factors and agents that affect protein kinases and phosphorylation**

## Tamoxifen Treatment of Breast Cancer

Tamoxifen treatment achieves its greatest effect (50% reduction in recurrent disease) in estrogen receptor-positive tumors, but it is also effective in estrogen receptor-negative tumors. Most importantly, it is now recognized that acquired resistance eventually develops. Therefore, there are two important questions. Why is tamoxifen treatment effective with estrogen receptor-negative tumors? How does tamoxifen resistance develop (**Figure 1.26**)?



**FIGURE 1.26**

## Efficacy of Tamoxifen with Estrogen Receptor–Negative Tumors

Besides binding to the estrogen receptor and providing competitive inhibition, tamoxifen has the following actions:

1. Tamoxifen and clomiphene inhibit protein kinase C activity (phosphorylation).
2. Tamoxifen inhibits calmodulin-dependent cyclic AMP phosphodiesterase, by binding to calmodulin.
3. Tamoxifen and estrogen have opposing effects on growth factors.<sup>150,151</sup> Tamoxifen stimulates secretion of transforming growth factor- $\beta$  (TGF- $\beta$ ) in breast cancer cells as well as in fibroblasts and stromal cells, and TGF- $\beta$  inhibits growth of breast cancer cells, whereas estrogen and insulin decrease the secretion of TGF- $\beta$  in cancer cells. Tamoxifen decreases and estrogen increases IGF-I and insulin-like growth factor II (IGF-II) production in stromal fibroblasts.

Some of these actions (especially inhibition of protein kinase activity and stimulation of TGF- $\beta$  production) occur independently of tamoxifen binding to the estrogen receptor, and, thus, estrogen receptor–negative tumors can be affected by these actions; however, the overall impact of tamoxifen on recurrence or death in women with estrogen receptor–poor tumors is negligible.<sup>138</sup>

## Mechanisms for Tamoxifen Resistance

The results of randomized clinical trials have indicated that there is little reason to

extend tamoxifen treatment of breast cancer patients beyond 5 years.<sup>142,152,153</sup> Indeed, the data suggested that survival and recurrence rates worsened with longer therapy, probably due to the emergence of tamoxifen-resistant tumors. There are several possible explanations for resistance, and whichever of these are operative, it is believed that a subpopulation resistant to tamoxifen is present from the beginning and over time grows to be clinically apparent.<sup>154</sup>

## Loss of Estrogen Receptors

Generally, it is believed that estrogen receptor expression is not a permanent phenotype of breast cancer cells; thus, tumors can change from receptor-positive to receptor-negative. But more than 50% of resistant tumors retain estrogen receptors.<sup>155</sup> The conventional wisdom has been that progression is associated with loss of cellular control and loss of estrogen receptor expression. However, the correlation between metastatic disease and estrogen receptor-negative state is not strong. Indeed, metastatic disease with estrogen receptor-positive cells despite an estrogen receptor-negative primary lesion has been reported. In addition, the rate of estrogen receptor expression is about the same in in situ disease and invasive disease. Most normal breast cells are estrogen receptor negative, and in vitro cell lines maintain their receptor status. Thus, there is little reason to believe that tamoxifen-resistant tumors lose receptor expression. The importance of this is that resistance is not a wild, potentially uncontrollable dedifferentiation.<sup>156</sup>

## Variant and Mutant Estrogen Receptors

Mutations in resistant breast tumors are uncommon and are not a frequent cause of resistance.<sup>157</sup> Studies of breast tumors from tamoxifen-resistant patients indicate that most express wild-type normal estrogen receptor. However, approximately 20% of metastatic ER+ breast tumors may harbor mutations in the estrogen-binding domain of the estrogen receptor; these mutations have been shown to confer partial resistance to tamoxifen.<sup>158</sup>

## Changes in Coactivators

If a breast cancer cell were to begin expressing these factors in a fashion similar to the endometrium or bone, then agonistic actions would occur.

## Cross Talk Between Signaling Pathways

Because of the synergism between the estrogen receptor and protein kinase pathways, stimulation of protein kinase pathways can change an antagonist message to agonism.<sup>159</sup>

This mechanism operates through the phosphorylation of the estrogen receptor or proteins involved in estrogen receptor-mediated transcription. Stimulation of this protein kinase phosphorylation activates the agonist activity of tamoxifen-like antiestrogens. Furthermore, the lack of response of pure antiestrogens to this phosphorylation may be part of the reason for the response of resistant tumors to pure antiestrogens.

## Binding to Other Proteins

A remote possibility is the prevention of action by binding to other proteins, such as anti-estrogen-binding sites, microsomal proteins that bind to tamoxifen with high affinity but do not bind estrogen.<sup>160</sup>

## Differential Cellular Transport

Overexpression of the transmembrane efflux pump that excretes compounds from cells could diminish the intracellular amount of tamoxifen present.

## Differential Metabolism

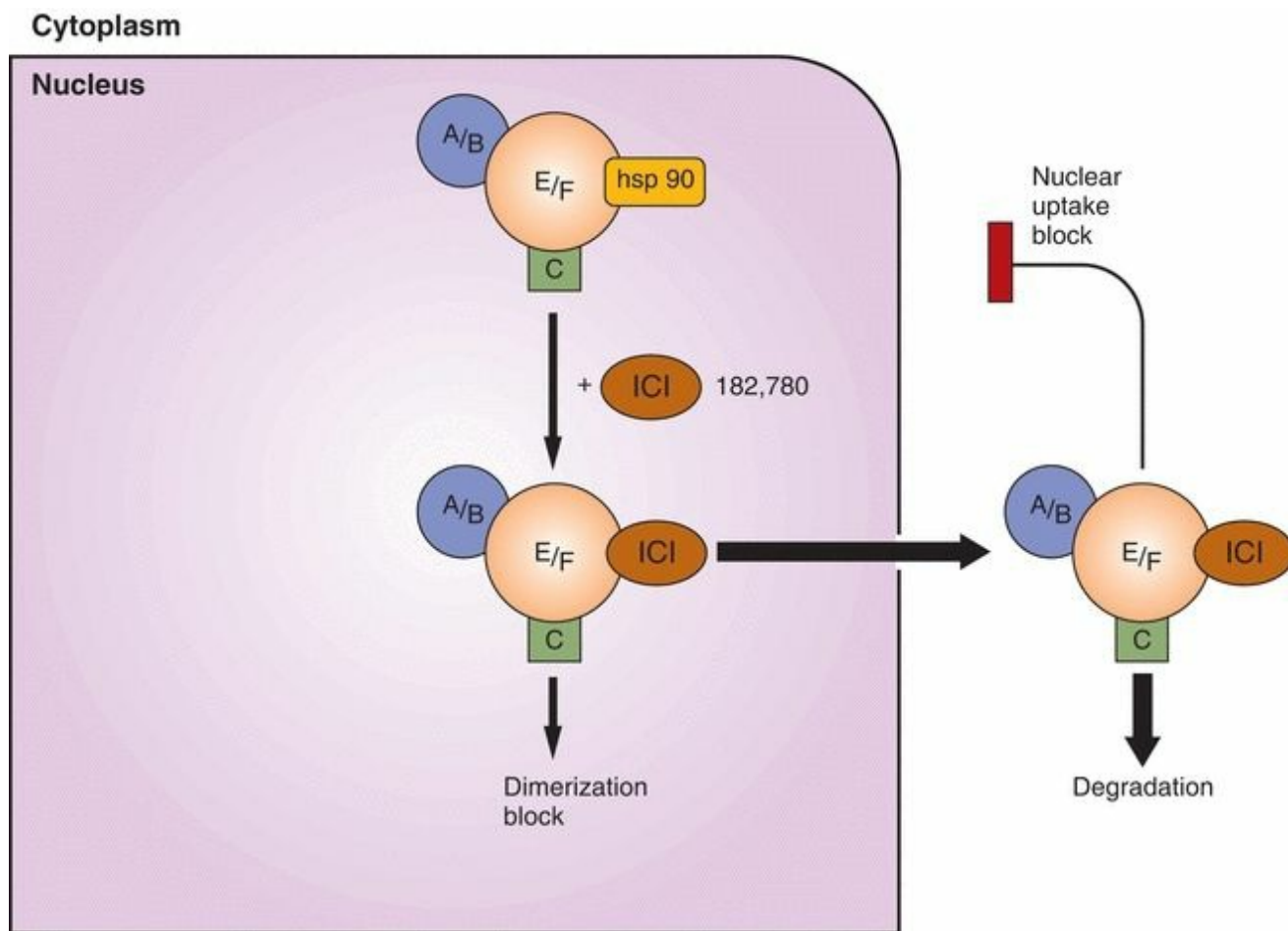
Changes in pharmacology and metabolism of tamoxifen might occur so that cells acquire the ability to metabolize the antagonist to greater agonist activity. Some breast cancer patients develop tumors that regress when tamoxifen is withdrawn. However, estrogenic metabolites of tamoxifen have not been identified.

Tamoxifen resistance occurs because essentially, the estrogen receptor is not the dominant mechanism involved in the growth of these cells. Evidence supports growth factor stimulation and kinase phosphorylation as the predominant systems in tamoxifen-resistant cells. These cells are hypersensitive to estrogen and respond to tamoxifen as an agonist.<sup>161</sup>

Randomized trials have demonstrated the superiority of aromatase inhibitors compared with tamoxifen for the treatment of hormone-sensitive early breast cancer. This includes better disease-free survival, a reduction in new contralateral primary tumors, and an increased time to recurrence. Because of this superiority, the standard has shifted from tamoxifen to aromatase inhibitors for postmenopausal women with ER+ breast cancer (as discussed in [Chapter 16](#)). Nevertheless, tamoxifen made a major contribution to the molecular understanding of hormonal action.

# The Pure Antiestrogens

The pure antiestrogens are derivatives of estradiol with long hydrophobic side chains at the 7 position (Figure 1.24). Binding with the pure antiestrogens prevents DNA binding. Because the site responsible for dimerization overlaps with the hormone-binding site, it is believed that pure antiestrogens sterically interfere with dimerization and thus inhibit DNA binding. In addition, these compounds increase the cellular turnover of estrogen receptor, and this action contributes to its antiestrogen effectiveness. One such antiestrogen, fulvestrant (ICI 182, 780), is used to treat metastatic breast cancer that has failed to respond to the usual endocrine therapy.<sup>162</sup> The estrogen receptor combined with fulvestrant is immobilized in the cell and rapidly undergoes degradation.<sup>163,164</sup> The half-life of the estrogen receptor when occupied with estradiol is about 5 hours; when occupied with a pure antiestrogen, it is less than 1 hour (Figure 1.27).



**FIGURE 1.27**

# **Estrogen Agonists/Antagonists (Also Known as Selective Estrogen Receptor Modulators, SERMs)**

This class of synthetic compounds is characterized by a fundamental principle: the conformational shape produced after binding to the receptor results in modified action, influenced by the cellular context of adapter (regulating) proteins and which of these proteins are selected. Tamoxifen rightfully belongs to this family, and its use stimulated the pursuit of a related drug that would not stimulate the endometrium. Agents such as raloxifene and lasofoxifene have antiestrogenic activity in the uterus as well as in the breast and at the same time exert agonistic effects in certain target tissues.<sup>136</sup> Raloxifene inhibits bone resorption and improves lipids (although there is no effect on HDL cholesterol). By virtue of variations in conformational changes in the drug-receptor complex and the cellular context of specific tissues, drugs such as these can be developed to produce beneficial effects in certain target systems (such as bone) and to avoid unwanted actions (such as endometrial stimulation). The unique conformational shape raloxifene produces when it binds to the estrogen receptor prevents the involvement of a required coactivator protein at the AF-2 site. In target tissues that respond principally to AF-2 gene transcription, these agents will lack estrogenic activity; however, in tissues with the appropriate cellular context of proteins, estrogenic gene transcription can occur through the AF-1 mechanism. In tissues that respond principally to the estrogen receptor- $\beta$  that lacks AF-1 activity or when target tissues lack coactivating proteins that interact with AF-1, these agents will be pure estrogen antagonists.

# Antiprogestins

Both progesterone and the antiprogestins, such as mifepristone (RU-486) and onapristone, form hormone-responsive element-receptor complexes that are similar, but the antiprogestin complex has a slightly different conformational change (in the hormone-binding domain) that prevents full gene activation.<sup>165</sup> RU-486 has some agonistic activity due to its ability to activate certain, but not all, of the transcription activation functions on the progesterone receptor; the final biologic response is modulated by the target tissue context of coactivators and corepressors.<sup>166</sup> While mifepristone is best known for its abortifacient activity, the combination of its agonistic and antagonistic actions can be exploited for many uses, including contraception, medical treatment of endometriosis, induction of labor, treatment of Cushing syndrome, and, potentially, treatment of various cancers.

The search for inhibitors of progesterone binding began many years ago, in the late 1960s, but it wasn't until the early 1980s that mifepristone, the first successful antiprogestin, was produced by scientists at Roussel Uclaf, a pharmaceutical company in Paris. Mifepristone is a 19-nortestosterone derivative. The dimethyl (dimethylaminophenyl) side chain at carbon 11 is the principal factor in its antiprogestone action. Three major characteristics of its action are important: a long half-life, high affinity for the progesterone receptor, and active metabolites.

The affinity of mifepristone for the progesterone receptor is five times greater than that of the natural hormone. In the absence of progesterone, it can produce an agonistic (progesterone) effect. It does not bind to the estrogen receptor, but it can act as a weak antiandrogen because of its low-affinity binding to the androgen receptor. Mifepristone also binds to the glucocorticoid receptor, but higher doses are required to produce effects. The binding affinity of mifepristone and its metabolites for the glucocorticoid receptor is very, very high. The reason why it takes such a high dose to produce an effect via this receptor is because the circulating level of cortisol is so high, 1,000-fold higher than progesterone. These receptor-binding properties allow titration of clinical effects by adjustments of dose.

Both progesterone and mifepristone induce conformational changes with the progesterone receptor, especially in the hormone-binding domain.<sup>167,168</sup> Thus, the antiprogestin not only competes with progesterone for the progesterone receptor, but after binding to the hormone-binding domain, the receptor structure is altered in such a way that the transcription activity of the B progesterone receptor is inhibited. In cells where the A progesterone receptor is expressed, antiprogestin binding stimulates A receptor-induced inhibition of transcription activity for all steroid hormone receptors (this would explain the antiestrogen activity of mifepristone).

Another clinically useful progesterone receptor modulator is ulipristal acetate. Through its primarily antiprogestogenic action, it is useful as an emergency contraceptive agent (by delaying ovulation and, likely, by altering endometrial receptivity) and for the management of symptomatic leiomyomata. Like mifepristone, ulipristal acetate binds to glucocorticoid and androgen receptors at high dose concentrations.



# Androgen Antagonists

The two most commonly used androgen antagonists are cyproterone acetate and spironolactone. Cyproterone and spironolactone bind to the androgen receptor and exert mixed agonism-antagonism. In the presence of significant levels of androgens, the antagonism predominates, and these agents are effective for the treatment of hirsutism. Flutamide is a nonsteroidal pure antiandrogen, effectively blocking androgenic action at target sites by competitive inhibition.

# OTHER MECHANISMS OF HORMONE ACTION

---

Central to the regulation of steroid hormone synthesis and release are the actions of the tropic hormones. Tropic hormones include the releasing hormones originating in the hypothalamus and a variety of peptides and glycoproteins secreted by the anterior pituitary gland and placenta. To understand their mechanisms of action, it is important to first consider the general ways in which nonsteroid hormones can activate receptors.

The many different types of receptors can be organized into the following basic categories.

# **G Protein Receptors**

These receptors are composed of a single polypeptide chain that spans the cell membrane. Binding to a specific hormone leads to interaction with G proteins that, in turn, activate second messengers. Examples include receptors for tropic hormones, prostaglandins, light, and odors. The second messengers include the adenylate cyclase enzyme and the phospholipase system.

# **Ion Gate Channels**

These cell surface receptors are composed of multiple units that, after binding, open ion channels. The influx of ions changes the electrical activity of the cells. One example of this type is the nicotinic acetylcholine receptor.

# **Receptors with Intrinsic Enzyme Activity**

These transmembrane receptors have an intracellular component with tyrosine or serine kinase activity. Binding leads to receptor autophosphorylation and activity. Examples include the receptors for insulin and growth factors (tyrosine kinase) and the receptors for activin and inhibin (serine kinase).

# **The System of Internalization**

Receptors that do not fit the above categories include the receptors for LDL, prolactin, growth hormone, and some of the growth factors. These receptors allow entry of their ligands into cells by the process of endocytosis (discussed later in this chapter).

# MECHANISM OF ACTION FOR TROPIC HORMONES

---

The specificity of tropic hormones depends on the presence of a receptor in the cell membrane of the target tissue. Tropic hormones do not enter the cell to stimulate physiologic events but unite with a receptor on the surface of the cell.

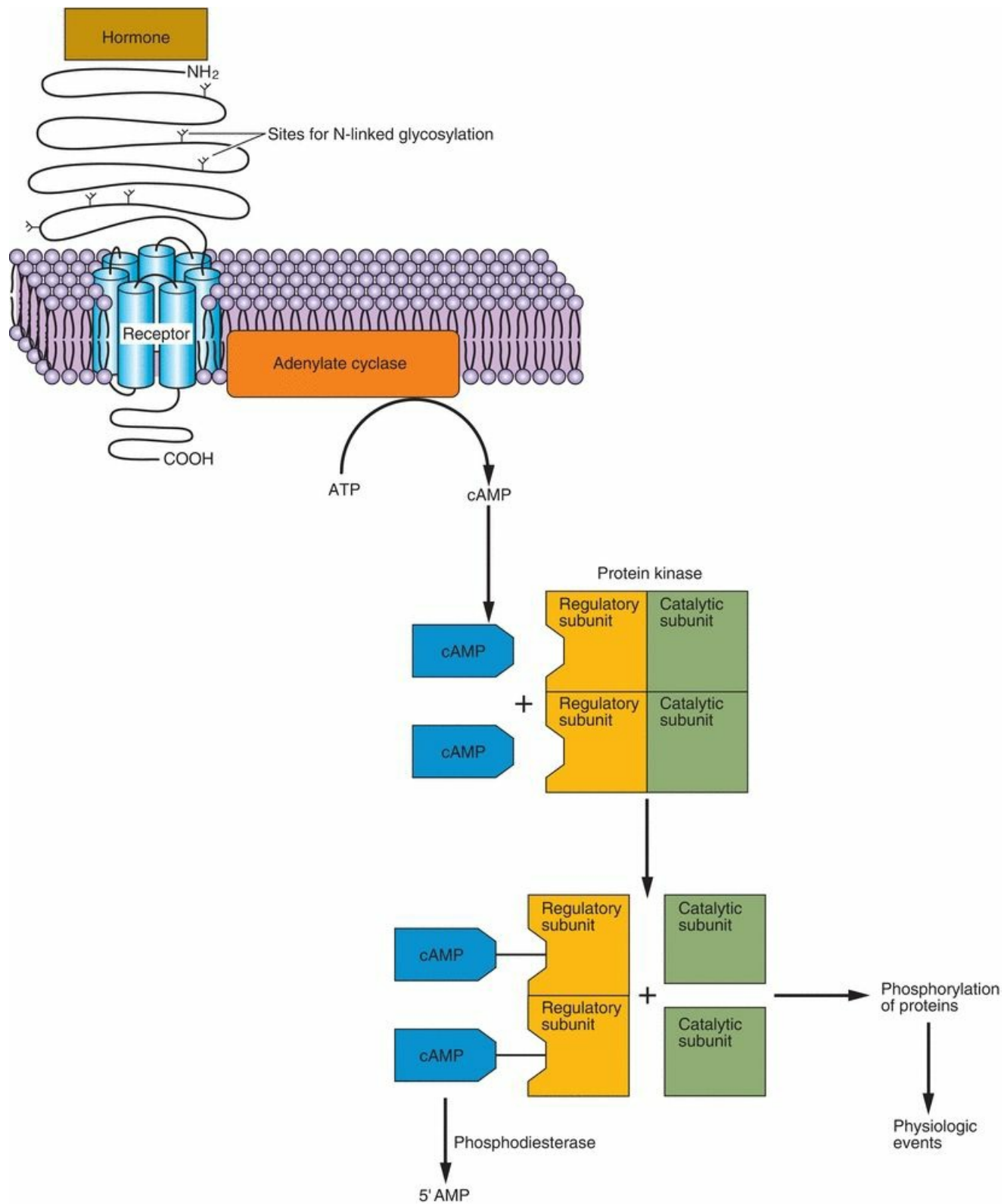
The receptor protein in the cell membrane can act as the active agent and, after binding, operate as an ion channel or function as an enzyme, as described in the general mechanisms above. Alternatively, the receptor protein is coupled to an active agent, an intracellular messenger. The major intracellular messenger molecules are cyclic AMP, inositol 1,4,5-triphosphate (IP<sub>3</sub>), 1,2-diacylglycerol (1,2-DG), calcium ion, and cyclic guanosine 3',5'-monophosphate (cyclic GMP). Because G protein receptors play a large role, it is worth taking a closer look at their general structure and function.

# The G Protein System

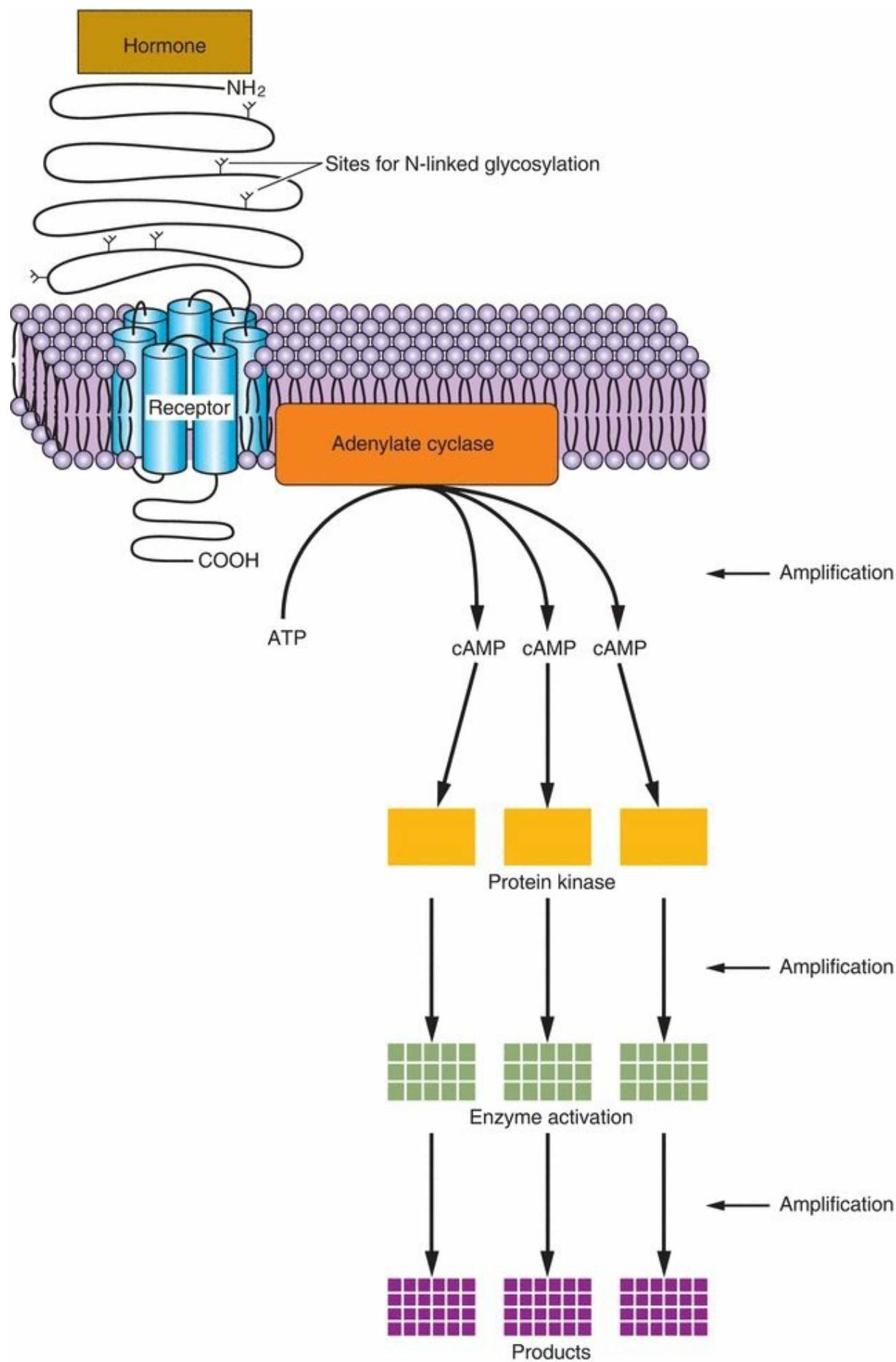
The 1994 Nobel Prize in Medicine and Physiology was awarded to Alfred G. Gilman and Martin Rodbell for the discovery and description of G proteins. Adenylate cyclase is composed of three protein units: the receptor, a guanyl nucleotide regulatory unit, and a catalytic unit.<sup>169</sup> The regulatory unit is a coupling protein, regulated by guanine nucleotides (specifically guanosine 5'-triphosphate, GTP), and therefore it is called GTP-binding protein or G protein for short.<sup>170,171</sup> The catalytic unit is the enzyme itself that converts ATP to cyclic AMP. The receptor and the nucleotide regulatory unit are structurally linked, but inactive until the hormone binds to the receptor. Upon binding, the complex of hormone, receptor, and nucleotide regulatory unit is activated leading to an uptake of GTP by the regulatory unit. The activation and uptake of GTP result in an active enzyme that can convert ATP to cyclic AMP. This result can be viewed as the outcome of the regulatory unit **coupling** with the catalytic unit, forming an intact complete enzyme. Enzyme activity is then terminated by hydrolysis of the GTP to guanosine 5'-diphosphate (GDP) returning the enzyme to its inactive state. Quick action and acute control of adenylate cyclase are assured because the G protein is a GTPase that self-activates upon binding of GTP.

The G protein has been purified. From the amino acid sequence, complementary DNA clones have been produced. These studies have indicated that a family of G proteins exists that couples receptors to active ligands, playing roles in signal transduction, intracellular transport, and exocytosis. The ability of the hormone-receptor complex to work through a common messenger (cyclic AMP) and produce contrasting actions (stimulation and inhibition) is thought to be due to the presence of both stimulatory nucleotide regulatory G proteins and inhibitory nucleotide regulatory G proteins (**Figures 1.28** and **1.29**).<sup>172,173</sup> However, the G protein system is not limited to the cyclic AMP signal, but can activate other messenger-generating enzymes, as well as ion channels.





**FIGURE 1.28**



## FIGURE 1.29

The G proteins are composed of  $\alpha$ -,  $\beta$ -, and  $\gamma$ -subunits, each the product of many distinct genes.<sup>174</sup> The  $\beta$ - and  $\gamma$ -subunits are not all alike, and they exhibit selectivity for specific ligands. Indeed, there are several hundred G protein receptors, with a common structure but sufficiently dissimilar to be activated by different ligands. Each G protein has a unique  $\alpha$ -subunit, and there are 16 mammalian  $\alpha$ -subunit genes. Based on amino acid similarities, they are grouped into four subfamilies:  $G_s\alpha$ ,  $G_q\alpha$ ,  $G_i\alpha$ , and  $G_{12}$ .  $G_s$  and  $G_q$  proteins mediate stimulatory events such as hormone secretion, whereas  $G_i$  proteins exert inhibition. The role of the  $G_{12}$  group is not yet certain. These multiple subunits allow great variability in function to be expressed by many different combinations that produce conformational changes linked to message transmission.

In the inactive state, GDP is bound to the  $\alpha$ -subunit. Hormone-receptor interaction and binding change the  $\alpha$ -subunit conformation. GTP replaces GDP on the  $\alpha$ -subunit, freeing the  $\beta$ - and  $\gamma$ -subunits, which allows the GTP  $\alpha$ -subunit to bind to the catalytic unit of adenylate cyclase, forming the active enzyme. The GTP  $\alpha$ -subunit can also activate other messengers, such as ion channels. Intrinsic GTPase activity quickly hydrolyzes the GTP- $\alpha$  to GDP- $\alpha$ , which leads to reassociation with the  $\beta$ - and  $\gamma$ -subunits, reforming the G protein complex for further activation. The functional specificity is due to the  $\alpha$ -subunit, which differs for each G protein, and therefore there are many different  $\alpha$ -subunits encoded by different genes.

# The G Protein Receptors

The more than 200 receptors linked to G proteins are derived from a supergene family; the 800 genes presumably originated from a common ancestral gene.<sup>175</sup> The gonadotropin receptor contains a transmembrane region that has the structural features of a receptor that couples with G protein and a large extracellular domain.<sup>176</sup> Receptors that utilize the G proteins are inserted in membranes and consist of a long polypeptide chain that folds into seven helices; the amino acid loops that connect the helices extend either into the cytoplasm or into the extracellular space. The amino end extends outside the cell, and the carboxyl end extends into the cell. The large extracellular segment is the site for specific gonadotropin recognition and binding. Binding changes the conformation (which is associated with phosphorylation), leading to interaction with the G proteins, which in turn activate second messengers, either enzymes or ion channels. These are ancient proteins; for example, they are used by yeast to detect mating pheromones (perhaps, this is why this protein is the basic structure for sight and smell in higher organisms; rhodopsin is a G protein located in the light-sensitive rod of the retina). Thus, the G receptors can be activated by hormones, neurotransmitters, growth factors, odorants, and photons of light.

LH and hCG bind to a common receptor, encoded by genes on chromosome 2p21. The LH/hCG receptor is highly conserved in mammals; the human receptor is very similar to that of rat and bovine receptors.<sup>177</sup> It is likely that expression of the LH/hCG receptor is regulated by many factors, including endocrine, paracrine, and autocrine mechanisms, but the primary requirement is FSH. In addition to the G protein pathway, activation of the LH/hCG receptor stimulates the calcium messenger system.

The receptor for FSH is very similar to the LH/hCG receptor, but it is structurally distinct.<sup>178,179</sup> Appropriately (for specificity), the extracellular segment contains the major sequence divergence. The FSH receptor gene is located on chromosome 2p21–16, near the LH/hCG receptor gene. The FSH receptor is also regulated by its hormone environment, especially by FSH and estradiol. Other members of this family include receptors for thyroid-stimulating hormone (TSH), catecholamines, vasopressin, angiotensin II, and dopamine.

# Mutations in the G Protein System

Rare mutations that alter the structure and activity of G proteins can result in disease.<sup>171,174,180,181,182,183</sup> Loss of function mutations of a G protein or a given receptor will result in hormone deficiency syndromes, for example, the TSH receptor and hypothyroidism, the LH receptor and male pseudohermaphroditism, and pseudohypoparathyroidism due to a  $G_s\alpha$  mutation. Activation of gonadotropin-releasing hormone (GnRH) at puberty is mediated by kisspeptin 1, a ligand that binds to its G protein receptor on GnRH neurons; an inactivating mutation in this receptor causes hypogonadism and delayed or absent puberty. Mutations in the G protein receptor for GnRH have been identified that are responsible for familial hypogonadism. The McCune-Albright syndrome (sexual precocity, polyostotic fibrous dysplasia, café au lait skin pigmentation, and autonomous functioning of various endocrine glands) is due to unregulated activity (gain in function) of the adenylate cyclase system because of a mutation in the  $G_s\alpha$  gene.  $G_s\alpha$  protein mutations have also been found in adrenal and ovarian tumors, growth hormone–secreting pituitary adenomas, and thyroid adenomas. It is possible that alterations in the G protein system may ultimately explain abnormalities in endocrine-metabolic functions, as well as oncogenic mutations.<sup>172,173,184</sup>

Besides mutations, altered G protein receptor function can be due to polymorphisms, slight genetic changes that can be associated with altered physiology or disease. Single nucleotide polymorphisms (SNPs) associated with these receptors are being identified, and correlations are being made with risks and outcomes for diseases.<sup>185</sup> This is an avenue of genetic research that is bound to reveal explanations for some instances of infertility or problems of sexual differentiation (Table 1.4).

## TABLE 1.4 Some Genetic Diseases Due to Specific G-Protein System Mutations

<b>Mutation</b>	<b>Disorder</b>
Activating LH receptor	Precocious puberty in boys
Inactivating LH receptor	Male pseudohermaphroditism
Activating FSH receptor	Ovarian hyperstimulation
Inactivating FSH receptor	Premature ovarian failure
Inactivating TRH receptor	Hypothyroidism
G <sub>s</sub> a (stimulatory)	McCune-Albright syndrome
G <sub>i</sub> a (inhibitory)	Hypothyroidism
Rhodopsin	Retinitis pigmentosa
Activating vasopressin receptor	Diabetes insipidus

# The Cyclic AMP Mechanism

Cyclic AMP is the intracellular messenger for FSH, LH, human chorionic gonadotropin (hCG), TSH, and ACTH. Union of a tropic hormone with its cell membrane G protein receptor activates the adenylate cyclase enzyme within the cell membrane leading to the conversion of adenosine 5'-triphosphate (ATP) within the cell to cyclic AMP. Specificity of action and/or intensity of stimulation can be altered by changes in the structure or concentration of the receptor at the cell membrane-binding site. In addition to changes in biologic activity due to target cell alterations, changes in the molecular structure of the tropic hormone can interfere with cellular binding and physiologic activity.

The cell's mechanism for sensing the low concentrations of circulating tropic hormone is to have an extremely large number of receptors but to require only a very small percentage (as little as 1%) to be occupied by the tropic hormone. The cyclic AMP released is specifically bound to a cytoplasm receptor protein, and this cyclic AMP-receptor protein complex activates a protein kinase. The protein kinase is present in an inactive form as a tetramer containing two regulatory subunits and two catalytic subunits. Binding of cyclic AMP to the regulatory subunits releases the catalytic subunits, with the regulatory subunits remaining as a dimer. The catalytic subunits catalyze the phosphorylation of serine and threonine residues of cellular proteins such as enzymes and mitochondrial, microsomal, and chromatin proteins. The physiologic event follows this cyclic AMP-mediated energy-producing event. Cyclic AMP is then degraded by the enzyme phosphodiesterase into the inactive compound, 5'-AMP.

Most noteworthy, the genome contains responsive elements that bind proteins phosphorylated by the catalytic units, thus leading to activation of gene transcription. The **cyclic AMP-responsive element (CRE)** functions as an enhancer element upstream from a gene's transcription start site.<sup>186</sup> A large family of transcription factors interact with the CRE, creating an important regulatory unit for gene transcription. Cyclic AMP activates a specific transcription factor, cyclic AMP regulatory element-binding protein (CREB); the binding of CREB to CRE activates many genes. This system can also involve DNA sequences upstream from the CRE site.

The cyclic AMP system can be regarded as an example of evolutionary conservation. Rather than developing new regulatory systems, certain critical regulators have been preserved from bacteria to mammals. How is it that a single intracellular mediator can regulate different events? This is accomplished by turning on different biochemical processes governed by the different gene expression in individual cells. In addition, the adenylate cyclase enzyme exists in several isoforms, which respond either with stimulation or inhibition to various systems and agents.<sup>187</sup>

The cyclic AMP system provides a method for amplification of the faint hormonal signal swimming in the sea of the bloodstream. Each cyclase molecule produces a lot of cyclic AMP; the protein kinases activate a large number of molecules that in turn lead to an even greater number of products. This is an important part of the sensitivity of the endocrine system, a major reason why only a small percentage of the cell membrane receptors need be occupied in order to generate a response.

Prostaglandins stimulate adenylate cyclase activity and cyclic AMP accumulation. Despite the effect on adenylate cyclase, prostaglandins appear to be synthesized after the action of cyclic AMP. This implies that tropic hormone stimulation of cyclic AMP occurs first; cyclic AMP then activates prostaglandin synthesis, and, finally, intracellular prostaglandin moves to the cell membrane to facilitate the response to the tropic hormone. In addition to actions mediated by cyclic AMP, prostaglandins can also operate through changes in intracellular concentrations of calcium.

Prostaglandins and cyclic GMP can participate in an intracellular negative feedback mechanism governing the degree of, or direction of, cellular activity (e.g., the extent of steroidogenesis or shutting off of steroidogenesis after a peak of activity is reached). In other words, the level of cellular function can be determined by the interaction among prostaglandins, cyclic AMP, and cyclic GMP.

There are differences among the tropic hormones. Oxytocin, insulin, growth hormone, prolactin, and human placental lactogen (hPL) do not utilize the adenylate cyclase mechanism. Receptors for prolactin, growth hormone, and a number of cytokines (including erythropoietin and interleukins) belong to a single transmembrane domain receptor family.<sup>188</sup> Studies of this receptor family indicate that prolactin operates through various signal transduction mechanisms, including ion channels and nuclear kinase activation.

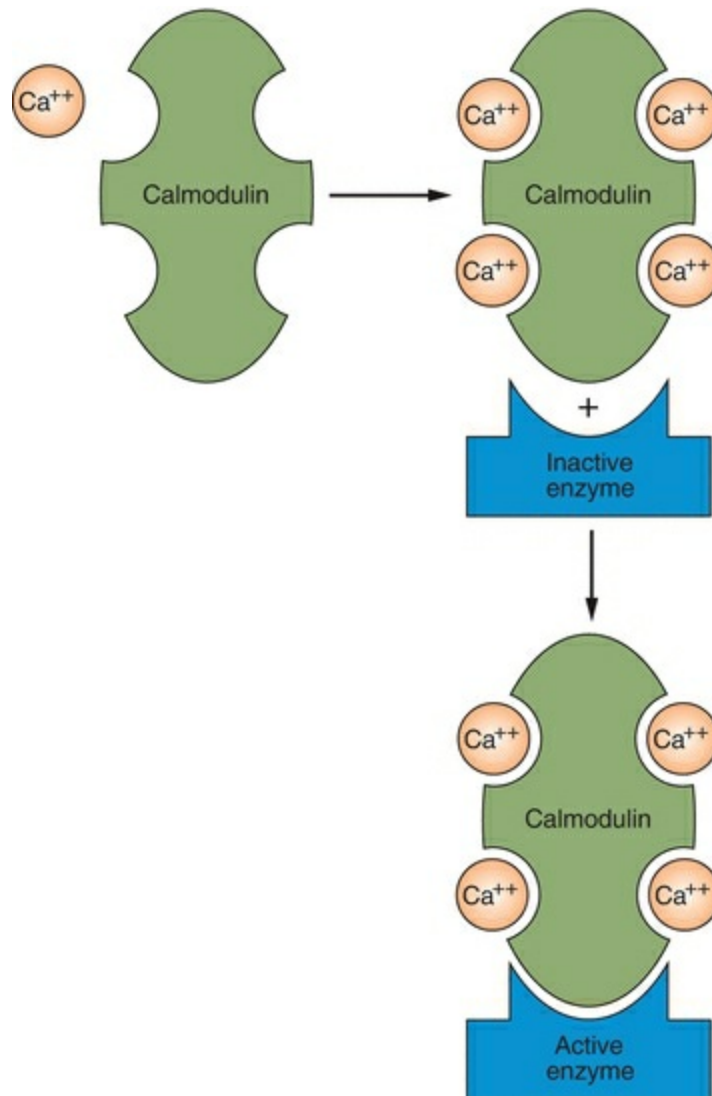


# The Calcium Messenger System

The intracellular calcium concentration is a regulator of both cyclic AMP and cyclic GMP levels.<sup>189</sup> Activation of the surface receptor either opens a channel in the cell membrane that lets calcium ions into the cell, or calcium is released from internal stores (the latter is especially the case in muscle). This calcium flux is an important intracellular mediator of response to hormones, functioning itself as a second messenger in the nervous system and in muscle.

The calcium messenger system is linked to hormone-receptor function by means of a specific enzyme, phospholipase C, which catalyzes the hydrolysis of polyphosphatidylinositols, specific phospholipids in the cell membrane. Activation of this enzyme by hormone binding to its receptor leads to the generation of two intracellular messengers, inositol triphosphate ( $IP_3$ ) and diacylglycerol (DAG), which initiate the function of the two parts of the calcium system. The first part is a calcium-activated protein kinase, responsible for sustained cellular responses, and the second part involves a regulator called calmodulin, responsible for acute responses. These responses are secondary to alterations in enzyme activity, especially protein kinases and transcription factors.

Calmodulin has been identified in all animal and plant cells that have been examined. Therefore, it is a very ancient protein. It is a single polypeptide chain of 148 amino acid residues whose sequence and structural and functional properties are similar to those of troponin C, the substance that binds calcium during muscle contractions, facilitating the interaction between actin and myosin. The calmodulin molecule has four calcium-binding sites, and binding with calcium gives a helical conformation, which is necessary for biologic activity (**Figure 1.30**). A typical animal cell contains more than 10 million molecules of calmodulin, constituting about 1% of the total cell protein. As a calcium regulatory protein, it serves as an intracellular calcium receptor and modifies calcium transport, enzyme activity, the calcium regulation of cyclic nucleotide and glycogen metabolism, and such processes as secretion and cell motility. Thus, calmodulin serves a role analogous to that of troponin C while mediating calcium's actions in noncontractile tissues, and cyclic AMP works together with calcium and calmodulin in the regulation of intracellular metabolic activity.



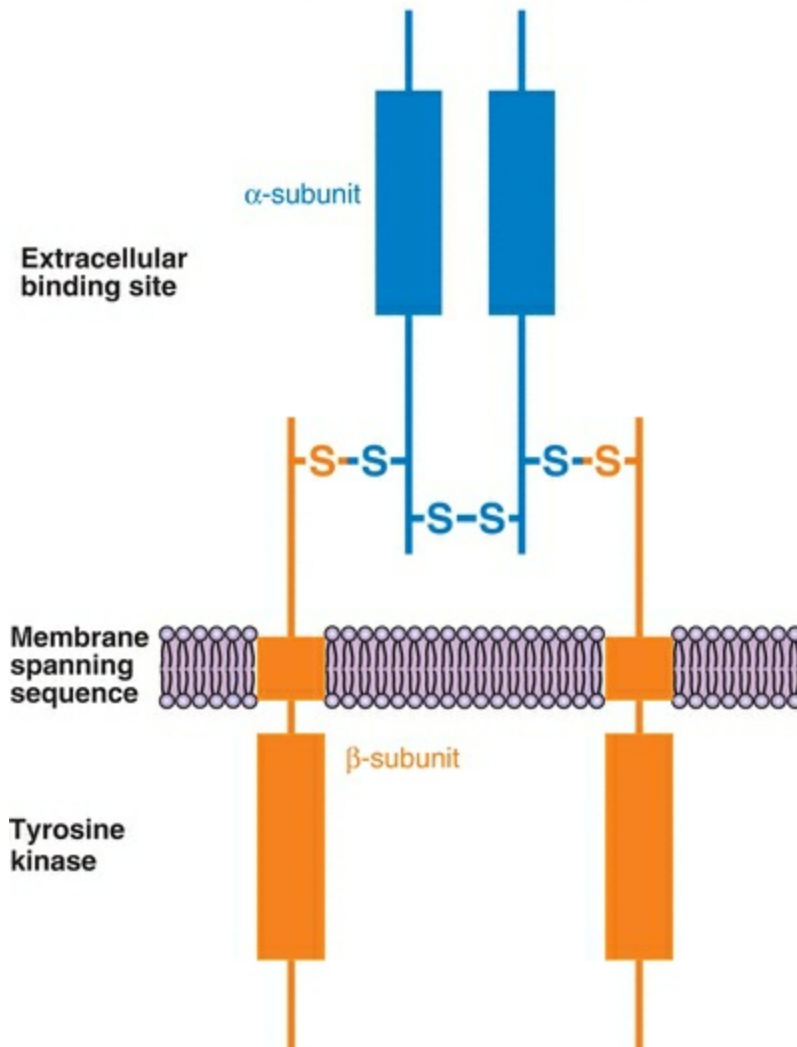
**FIGURE 1.30**

GnRH is one example of a receptor that is calcium dependent in its mechanism of action, utilizing IP<sub>3</sub> and 1,2-DG as second messengers to stimulate protein kinase activity.<sup>190</sup> These responses require a G protein and are associated with cyclical release of calcium ions from intracellular stores and the opening of cell membrane channels to allow entry of extracellular calcium.

# Kinase Receptors

The cell membrane receptors of insulin, insulin-like growth factor, EGF, platelet-derived growth factor, and FGF are tyrosine kinases. All tyrosine kinase receptors have a similar structure: an extracellular domain for ligand binding, a single transmembrane domain, and a cytoplasmic domain (**Figure 1.31**). The unique amino acid sequences determine a three-dimensional conformation that provides ligand specificity. The transmembrane domains are not highly conserved (thus differing in makeup). The cytoplasmic domains respond to ligand binding by undergoing conformational changes and autophosphorylation. The structure of the receptors for insulin and insulin-like growth factor is more complicated, with two  $\alpha$ - and two  $\beta$ -subunits, forming two transmembrane domains connected extracellularly by disulfide bridges. The receptors for the important autocrine and paracrine factors, activin and inhibin, function as serine-specific protein kinases.

### Insulin and Type I IGF Receptors Have a Similar Structure



**FIGURE 1.31**

Kinase activation requires distinctive sequences; thus, there is considerable homology among the kinase receptors in the cytoplasmic domain. Many of the substrates for these kinases are the enzymes and proteins in other messenger systems, for example, the calcium messenger system. Thus, the kinase receptors can cross-talk with other receptor-regulated systems that involve the G proteins.

# **REGULATION OF TROPIC HORMONE ACTION**

---

Modulation of the peptide hormone mechanism is an important biologic system for enhancing or reducing target tissue response. **The regulation of tropic hormone action can be divided into four major components:**

- 1. Autocrine and paracrine regulation factors**
- 2. Heterogeneity of tropic hormones**
- 3. Up- and down-regulation of receptors**
- 4. Regulation of adenylate cyclase**

# Autocrine and Paracrine Regulation Factors

Growth factors are polypeptides that modulate activity either in the cells in which they are produced or in nearby cells; hence, they are autocrine and paracrine regulators. Regulation factors of this type (yet another biologic family) are produced by local gene expression and protein translation, and they operate by binding to cell membrane receptors. The receptors usually contain an intracellular component with tyrosine kinase activity that is energized by a binding-induced conformational change that induces autophosphorylation. However, some factors work through other second messenger systems, such as cyclic AMP or IP<sub>3</sub>. Growth factors are involved in a variety of tissue functions, including mitogenesis, tissue and cellular differentiation, chemotactic actions, and angiogenesis. The growth factors involved in reproductive physiology include activin, inhibin, antimüllerian hormone (AMH), IGF-I, IGF-II, TGF- $\beta$ , FGF, and EGF.

In addition to the growth factors, various immune factors, especially cytokines, modulate ovarian steroidogenesis. These factors, including interleukin-1, tumor necrosis factor, and interferon, are found in human follicular fluid and, in general, inhibit gonadotropin stimulation of steroidogenesis.

For mitogenesis to occur, cells may require exposure to a sequence of growth factors, with important limitations in duration and concentrations. Growth factors are important for the direction of embryonic and fetal growth and development. In cellular differentiation, growth factors can operate in a cooperative, competitive, or synergistic fashion with other hormones. For example, IGF-I plus FSH, but not IGF-I alone, increases the number of LH receptors, progesterone synthesis, and aromatase activity in granulosa cells.<sup>191</sup>

Activin and inhibin are disulfide-linked dimers composed of peptide subunits (one  $\alpha$ -subunit and two  $\beta$ -subunits) as shown in [Table 1.5](#).<sup>192</sup>

## TABLE 1.5 Peptide Subunits

---

**Major forms of activin**

Activin-A

Beta<sub>A</sub>-Beta<sub>A</sub>

Activin-AB

Beta<sub>A</sub>-Beta<sub>B</sub>

Activin-B

Beta<sub>B</sub>-Beta<sub>B</sub>

---

**Major forms of inhibin**

Inhibin-A

Alpha-Beta<sub>A</sub>

Inhibin-B

alpha-Beta<sub>B</sub>

---

Each of the subunits is encoded by separate genes that produce precursor proteins that are cleaved to form the subunits. In addition, the free subunits and related monomeric products can be secreted. Despite the structural similarity between activin and inhibin, they function as antagonists in some systems (e.g., activin stimulates and inhibin inhibits FSH secretion). Activins, inhibins, and TGF- $\beta$  come from the same gene family, which also includes AMH. The activity of activin is regulated by protein binding, specifically to follistatin. Follistatin is a single-chain glycosylated peptide, structurally unrelated to inhibin and activin, that regulates the activin-inhibin system. Signaling by this family of peptides is accomplished by several receptor isoforms that are transmembrane serine kinases.

TGF- $\beta$  can either stimulate or inhibit growth and differentiation, depending on the target cell and the presence or absence of other growth factors. In the ovary, TGF- $\beta$  promotes granulosa cell differentiation by enhancing the actions of FSH (especially in expression of FSH and LH receptors) and antagonizing the down-regulation of FSH receptors. TGF- $\beta$  and the insulin-like growth factors are required for the maintenance of normal bone mass. EGF is a structural analog of TGF- $\alpha$  and is involved in mitogenesis. In the ovary, EGF, secreted by theca cells, is important for granulosa cell proliferation, an action opposed by TGF- $\beta$  (which is also secreted by the theca cells). The most potent mitogens are the two forms of FGF. Additional roles for FGF, secreted by the granulosa, include modulation of enzyme activity involved in the physical act of ovulation and angiogenic function during the development of the corpus luteum.

## The Insulin-Like Growth Factors

The insulin-like growth factors (called somatomedins in the past) are single-chain polypeptides that resemble insulin in structure and function.<sup>191</sup> These factors are widespread and are involved in growth and differentiation in response to growth

hormone and as local regulators of cell metabolism. IGF-II is more prominent during embryogenesis, whereas IGF-I is more active postnatally. Only the liver produces more IGF-I than the ovary. According to animal studies, both IGF-I and IGF-II are secreted by granulosa cells. IGF-I amplifies the action of gonadotropins and coordinates the functions of theca and granulosa cells. IGF-I receptors on the granulosa are increased by FSH and LH and augmented by estrogen. In the theca, IGF-I increases steroidogenesis. In the granulosa, IGF-I is important for the formation and increase in numbers of FSH and LH receptors, steroidogenesis, the secretion of inhibin, and oocyte maturation. It should be noted that the endogenous insulin-like growth factor in the human ovarian follicle is IGF-II in both the granulosa and the theca cells.<sup>193</sup> Studies indicating activity of IGF-I with human ovarian tissue can be explained by the fact that both IGF-I and IGF-II activities can be mediated by the type I IGF receptor that is structurally similar to the insulin receptor.

Granulosa cells also contain receptors for insulin, and insulin can bind to the IGF-I receptor. The IGF-I receptor is a heterotetramer with two  $\alpha$ - and two  $\beta$ -subunits in a structure similar to that of the insulin receptor. Insulin can bind to the  $\alpha$ -subunit ligand-binding domain and activate the  $\beta$ -subunit, which is a protein kinase. Thus, insulin can modulate ovarian cellular functions either through its own receptor or through the IGF-I receptor.

The biologic potency and availability of the insulin-like growth factors are further modulated by a collection of IGF-binding proteins that bind circulating insulin-like growth factors and also alter cellular responsiveness. Six insulin-like growth factor-binding proteins (IGFBP-1 through IGFBP-6) have been detected in serum and various tissues.<sup>194</sup> IGF-I and IGF-II circulate in the blood in a concentration 1,000 times greater than insulin; however, largely all of the circulating IGFs are bound to IGFBPs. The multiple IGFBPs and their proteases provide a mechanism for tissue-specific activities of IGFs. The various IGFBPs differ in their actions and individual expression, depending on the specific cell type and tissue. The principal IGFBP that regulates IGF biologic availability can vary according to metabolic changes. There are many possible permutations because the IGFBPs are not simply transport proteins; there are inhibitory and stimulatory IGFBPs that inhibit or potentiate IGF actions. Tissue-specific regulation of IGFBP protease activity can change the bioavailability of IGFs at specific sites. In addition, the IGFBPs have been demonstrated to have direct effects of their own, independent of IGF. Therefore, this is a complex regulatory system that provides both endocrine signals and autocrine and paracrine functions.



# Receptors Involved in Steroidogenesis

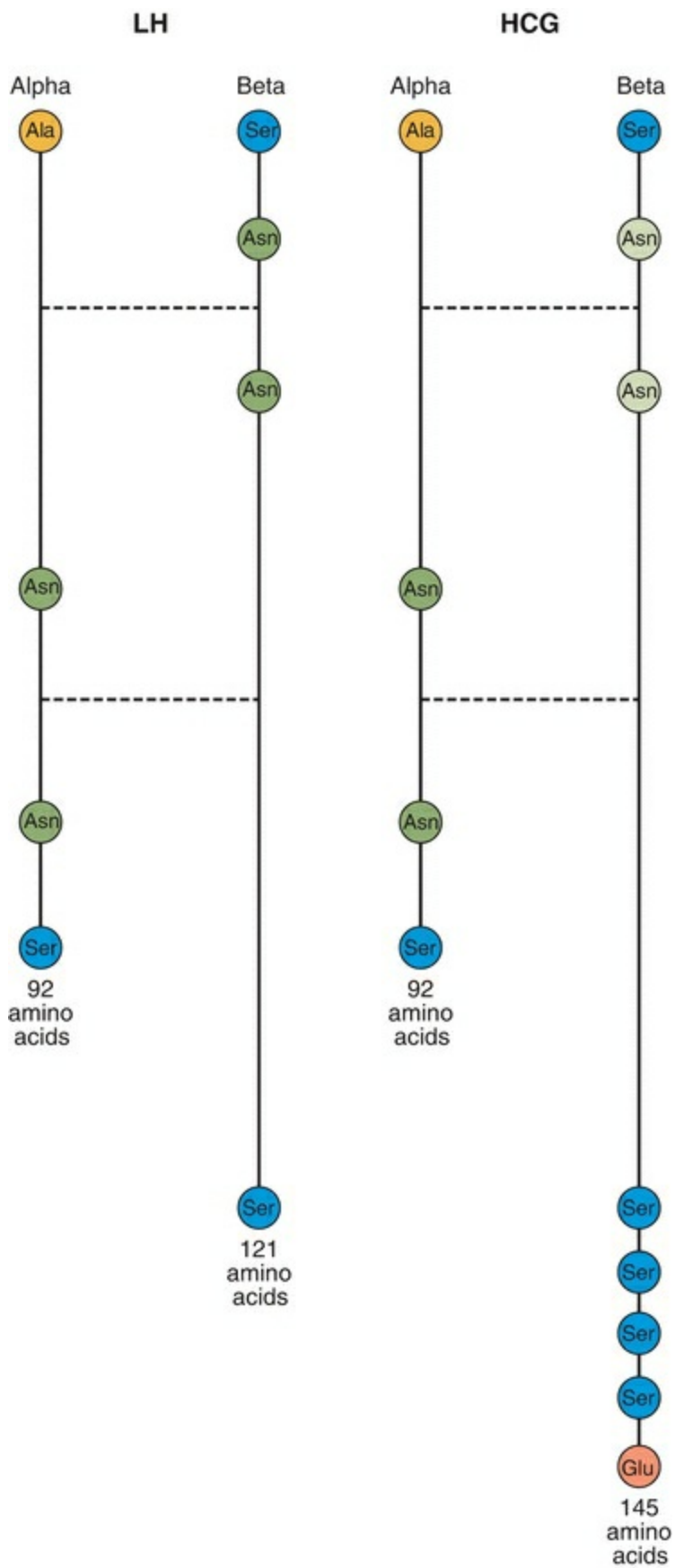
Steroidogenic factor-1 (SF-1) and DAX-1 (a name that represents Dosage-sensitive sex reversal-Adrenal hypoplasia congenita critical region on the X chromosome) are nuclear receptors for which specific ligands have not been identified (“orphan receptors”). SF-1 influences the expression of genes that encode steroidogenic enzymes, and when genetic expression of SF-1 is disrupted in mice, gonads and adrenal glands fail to develop.<sup>195,196</sup> In addition, SF-1 regulates transcription of the StAR gene.<sup>197</sup> Partial loss of SF-1 causes reduced ovarian activity and infertility.<sup>198</sup> Inactivating mutations in the DAX1 gene result in X-linked adrenal hypoplasia, which is also associated with hypogonadotropic hypogonadism.<sup>199</sup> DAX-1 is believed to work with SF-1 in regulating development and function of steroid-producing tissues as well as the regulation of gonadotropins.<sup>200</sup> SF-1 regulates genes that encode the gonadotropin subunits, as well as the GnRH receptor.<sup>196</sup> Thus, SF-1 and DAX-1 are involved at all levels: the hypothalamus, the pituitary, and the steroid-producing organs. These proteins function as transcription factors (as are the traditional nuclear hormone receptors such as the estrogen receptor) in the complex mechanisms being unraveled by molecular biologists.

# Heterogeneity of Tropic Hormones

The glycoproteins, such as FSH and LH, are not single proteins but should be viewed as a family of heterogeneous forms of varying immunologic and biologic activity.<sup>201</sup> The various forms (isoforms) arise in various ways, including different DNA promoter actions, alterations in RNA splicing, point mutations, and posttranslational carbohydrate changes.<sup>202</sup> The impact of the variations is to alter structure and metabolic clearance, thus affecting binding and activity. The isoforms have different molecular weights, circulating half-lives, and biologic activities. Throughout the menstrual cycle, the amazing number of at least 20–30 isoforms of both FSH and LH are present in the bloodstream.<sup>203</sup> **The overall activity of a glycoprotein, therefore, is due to the effects of the mixture of forms that reach and bind to the target tissue.**

The nonglycosylated subunit precursors of glycoprotein hormones are synthesized in the endoplasmic reticulum, followed by glycosylation. The glycosylated subunits combine and then are transported to the Golgi apparatus for further processing of the carbohydrate component. The units combine to form a compact heterodimer. The protein moiety binds to specific target tissue receptors, whereas the carbohydrate moiety plays a critical role in coupling the hormone-receptor complex to adenylate cyclase (perhaps by determining the necessary conformational structure).

The preciseness of the chemical makeup of the tropic hormones is an essential element in determining the ability of the hormone to mate with its receptor. The glycopeptides (FSH, LH, TSH, and hCG) are dimers composed of two glycosylated polypeptide subunits, the  $\alpha$ - and  $\beta$ -subunits. The  $\alpha$ - and  $\beta$ -subunits are tightly bound in a noncovalent association. The three-dimensional structure and the active conformation of the subunits are maintained by internal disulfide bonds.<sup>204</sup> All of the glycopeptides of the human species (FSH, LH, TSH, and hCG) share a common  $\alpha$ -chain, an identical structure containing 92 amino acids. The  $\beta$ -chains (or the  $\beta$ -subunits) differ in both amino acid and carbohydrate content, conferring the specificity inherent in the relationship between hormones and their receptors (**Figure 1.32**). Therefore, the specific biologic activity of a glycopeptide hormone is determined by the  $\beta$ -subunit; hypogonadism has been reported due to single amino acid substitution in the LH  $\beta$ -subunit.<sup>205</sup>



**FIGURE 1.32**

$\beta$ -hCG is the largest  $\beta$ -subunit, containing a larger carbohydrate moiety and 145 amino acid residues, including a unique carboxyl-terminal tail piece of 29 amino acid groups. It is this unique part of the hCG structure that allows the production of highly specific antibodies and the utilization of very specific immunologic assays. The extended sequence in the carboxyl-terminal region of  $\beta$ -hCG contains four sites for glycosylation (**Figure 1.32**); thus, hCG is glycosylated to a greater extent than LH, a difference that is responsible for the longer circulating half-life for hCG.

These differences in structure are associated with a different promoter and transcriptional site that is located upstream in the hCG  $\beta$ -subunit gene compared with the site in the LH  $\beta$ -subunit gene. The hCG  $\beta$ -subunit gene transcription site does not contain a hormone response element, allowing hCG secretion to escape feedback regulation by the sex steroids, in contrast to FSH and LH.

The rate-limiting step in the synthesis of gonadotropins and TSH is the availability of  $\beta$ -subunits, because excess  $\alpha$ -subunits can be found in blood and in tissue. Furthermore, the three-dimensional structure of the  $\beta$ -subunit, accomplished by folding the subunit by the formation of the disulfide bonds, is an important conformational step that is essential for assembly with the  $\alpha$ -subunit.<sup>206</sup> This conformational change is not completed until the subunits are fully united to produce the final whole hormone.

The half-life of  $\alpha$ -hCG is 6–8 minutes and that of whole hCG from the placenta about 24 hours. All human tissues appear to make hCG as a whole molecule, but the placenta is different in having the ability to glycosylate the protein, thus reducing its rate of metabolism and giving its biologic activity through a long half-life. The carbohydrate components of the glycoproteins are composed of fructose, galactose, mannose, galactosamine, glucosamine, and sialic acid. Although the other sugars are necessary for hormonal function, sialic acid is the critical determinant of biologic half-life. Removal of sialic acid residues in hCG, FSH, and LH leads to very rapid elimination from the circulation.

FSH consists of the  $\alpha$ -subunit of 92 amino acids and a  $\beta$ -subunit of 118 amino acids. It has four carbohydrate side chains, two on each subunit. The  $\beta$ -subunit of LH consists of 121 amino acids. LH has three carbohydrate side chains with a single glycosylation site (with less than half of the sialic acid in FSH). The initial half-life of LH is approximately 20 minutes, compared with the initial half-life of FSH of 3–4 hours.

Genes for tropic hormones contain promoter and enhancer or inhibitor regions located in the 5'-flanking regions upstream from the transcription site. These sites respond to second messengers (cyclic AMP) as well as steroids and other yet unknown regulators. The protein cores of the two glycoprotein subunits are the products of distinct genes.<sup>207</sup> Using recombinant DNA technology, it has been demonstrated that there is a single human gene for the expression of the  $\alpha$ -subunit. The gene for the  $\alpha$ -

subunit shared by FSH, LH, hCG, and TSH is located on chromosome 6q12.21. A single promoter site subject to multiple signals and hormones regulates transcription of the  $\alpha$  gene in both the placenta and pituitary. The  $\alpha$ -subunit gene is expressed in several different cell types, but the  $\beta$ -subunit genes are restricted in cell type. The TSH  $\beta$ -gene is expressed only in thyrotropes regulated by thyroid hormone; the FSH  $\beta$ -gene is expressed in gonadotropes regulated by GnRH, activin, inhibin, and gonadal steroids; the LH  $\beta$ -gene, also expressed in gonadotropes, is regulated by GnRH and unaffected by activin and inhibin<sup>208</sup>.

The  $\alpha$ -subunit gene requires the activation of distinct regulatory elements in thyrotrope and gonadotrope cells, as well as in the placenta. It is the activation of these cell-specific elements that produces tissue specificity for a gene expression. In gonadotropes, the GnRH signaling pathway for a gene transcription utilizes phosphorylase stimulation of diacylglycerol (DAG) and inositol triphosphate (IP<sub>3</sub>) that leads to a release of intracellular calcium stores. GnRH also stimulates the influx of calcium at the cell membrane. DAG, IP<sub>3</sub>, and calcium work together to stimulate protein kinase C activity. Protein kinase regulation of the  $\alpha$ -promoter is a principal part of the overall mechanism. This pituitary process is influenced by multiple factors, including growth factors and gonadal steroids. In the placenta, the mechanism also utilizes specific regulatory elements, but the primary signal is mediated by the cyclic AMP-protein kinase A pathway.

The gene for the FSH  $\beta$ -subunit is on chromosome 11p13. In the pituitary, its expression is markedly influenced by activin.<sup>209,210</sup> Although FSH and LH both require GnRH stimulation, the FSH  $\beta$ -gene is unique in that response to GnRH is dependent on activin.<sup>211</sup> With increasing GnRH stimulation, the role of activin is increasingly repressed by its binding protein, follistatin, the secretion of which is also stimulated by GnRH and activin. Activin is further antagonized by inhibin, the first of these factors recognized to suppress FSH secretion.<sup>212</sup>

The genes that encode for the  $\beta$ -subunits of LH, hCG, and TSH are located in a cluster on chromosome 19q13.32. There are six genes for the  $\beta$ -subunit of hCG, and only one for  $\beta$ -LH.<sup>213</sup> Transcription for the six hCG genes, each with different promoter activity, varies, and it is not certain why hCG requires multigenic expression (perhaps, this is necessary to reach the extremely high level of production in early pregnancy). It is thought that  $\beta$ -hCG evolved relatively recently from  $\beta$ -LH, and the unique amino acid terminal extension of  $\beta$ -hCG arose by a read-through mutation of the translation stop codon in the  $\beta$ -LH gene; the DNA sequences of the  $\beta$ -hCG genes and the  $\beta$ -LH gene are 96% identical.<sup>213</sup> Only primates and the equine species (horse, donkey, and zebra) have been demonstrated to have genes for the  $\beta$ -subunit of chorionic gonadotropin. In contrast to human chorionic gonadotropin, equine chorionic gonadotropin exerts both LH and

FSH activities in many mammalian species because it contains peptide sequences in its  $\beta$ -subunit that are homologous to those in the pituitary gonadotropins of other species. The equine  $\beta$ -chorionic gonadotropin gene is identical to the equine  $\beta$ -LH gene, and although the primate  $\beta$ -hCG gene evolved from the same ancestral  $\beta$ -LH gene, the horse chorionic gonadotropin gene evolved in a different way about 50 million years ago.<sup>214</sup> The  $\beta$ -LH gene is not expressed in the placenta.

A specific immunologic LH variant is relatively common. This variant is due to two point mutations in the LH  $\beta$ -subunit gene and is more common in people of northern European descent, reaching a carrier frequency of 41.9% in Lapps of northern Finland.<sup>215</sup> The clinical significance of this mutation is not known; however, routine immunoassays can provide falsely low readings because this variant is not detected. Inherited disorders because of disruptions in the coding sequences of both LH and FSH are in fact quite rare.<sup>216</sup>

The placenta-specific expression of  $\beta$ -hCG is due to several differences in DNA sequences between the  $\beta$ -hCG and  $\beta$ -LH genes.<sup>208</sup> The cyclic AMP-mediated enhancement of the  $\beta$ -hCG promoter is influenced by several regulatory proteins. The study of the  $\beta$ -subunit genes has been hampered by difficulties in maintaining glycoprotein-producing cell lines. The availability of choriocarcinoma cell lines, however, has allowed greater investigation of the  $\beta$ -hCG genes.

Although the  $\beta$ -subunit specifies the biologic activity of an individual glycoprotein, the combination of the  $\alpha$ - and  $\beta$ -subunits is necessary for full hormonal expression. Furthermore, the  $\alpha$ -subunit also plays an important role in accomplishing normal receptor binding and activation.<sup>217,218</sup> Neither subunit alone can effectively bind to the receptor with high affinity or exert biologic effect. In other words, binding and activation occur only when the hormone is in the combined  $\alpha$ - $\beta$  form. In addition, the  $\alpha$ -subunit influences the overall bioactivity of the glycoprotein hormones.<sup>219</sup> Thus, structural alterations in either the  $\alpha$ -subunit or the  $\beta$ -subunit could alter target tissue responses.

## Variations in Carbohydrate

The glycopeptide hormones can be found in the pituitary existing in a variety of forms, differing in their carbohydrate (oligosaccharides) makeup. The isoform mixture of gonadotropins is influenced both quantitatively and qualitatively by GnRH and the feedback of the steroid hormones, producing posttranslational carbohydrate modifications.<sup>220,221</sup> This heterogeneity in structure (which is also associated with heterogeneity in charge) represents a mechanism under endocrine control that modulates half-lives and bioactivity.

Certain clinical conditions can be associated with alterations in the usual chemical structure of the glycopeptides, resulting in interference with the ability to bind to receptors and stimulate biologic activity. In addition to deglycosylation and the formation of antihormones, gonadotropins can be produced with an increased carbohydrate content. A low-estrogen environment in the pituitary gland, for example, favors the production of the so-called big gonadotropins, gonadotropins with an increased carbohydrate component and, as a result, decreased biologic activity.<sup>222</sup> Immunoassay in these situations may not reveal the biologic situation; an immunoassay sees only a certain set of molecules but not all.

Bioactive levels of FSH and LH are very low in women receiving oral contraceptives and during the luteal and late follicular phases. The highest values are during the midcycle surge and in postmenopausal women (including women with premature ovarian failure).<sup>223</sup> The levels of bioactive FSH parallel those of immunoactive FSH with a constant ratio throughout the cycle. The greater bioactivity of FSH at midcycle is associated with less sialylated, shorter-lived isoforms. These changes are effects of both GnRH and estrogen.

The carbohydrate component, therefore, affects target tissue response in two ways: (1) metabolic clearance and half-life and (2) biologic activity. The circulating half-life of a gonadotropin is mainly proportional to the amount of sialic acid present.<sup>224</sup> The higher content of sialic acid in FSH compared with LH accounts for the more rapid clearance of LH from the circulation (the FSH half-life is several hours; the LH half-life is about 50 minutes). hCG is highly sialylated and, accordingly, has a half-life of 5–6 hours. However, clearance of gonadotropins as measured by half-lives is not explained totally by carbohydrate differences. Differences in amino acid sequences also contribute, and most importantly, the stability of the complete hormone (resisting dissociation into the rapidly cleared subunits) is a major factor.

Biologic activity is determined by both the binding and the activation of the hormone-receptor complex. Experimental data indicate that the carbohydrate chains have no role in the binding of gonadotropins to their receptors.<sup>225</sup> Nevertheless, removal of the carbohydrate moiety of either subunit diminishes gonadotropic activity. Therefore, the carbohydrate component affects the biologic activity of the hormone-receptor complex after binding. Specific studies indicate that the carbohydrate component plays a critical role in activation (coupling) of the adenylate cyclase system.<sup>226</sup>

## **Heterogeneity of Prolactin**

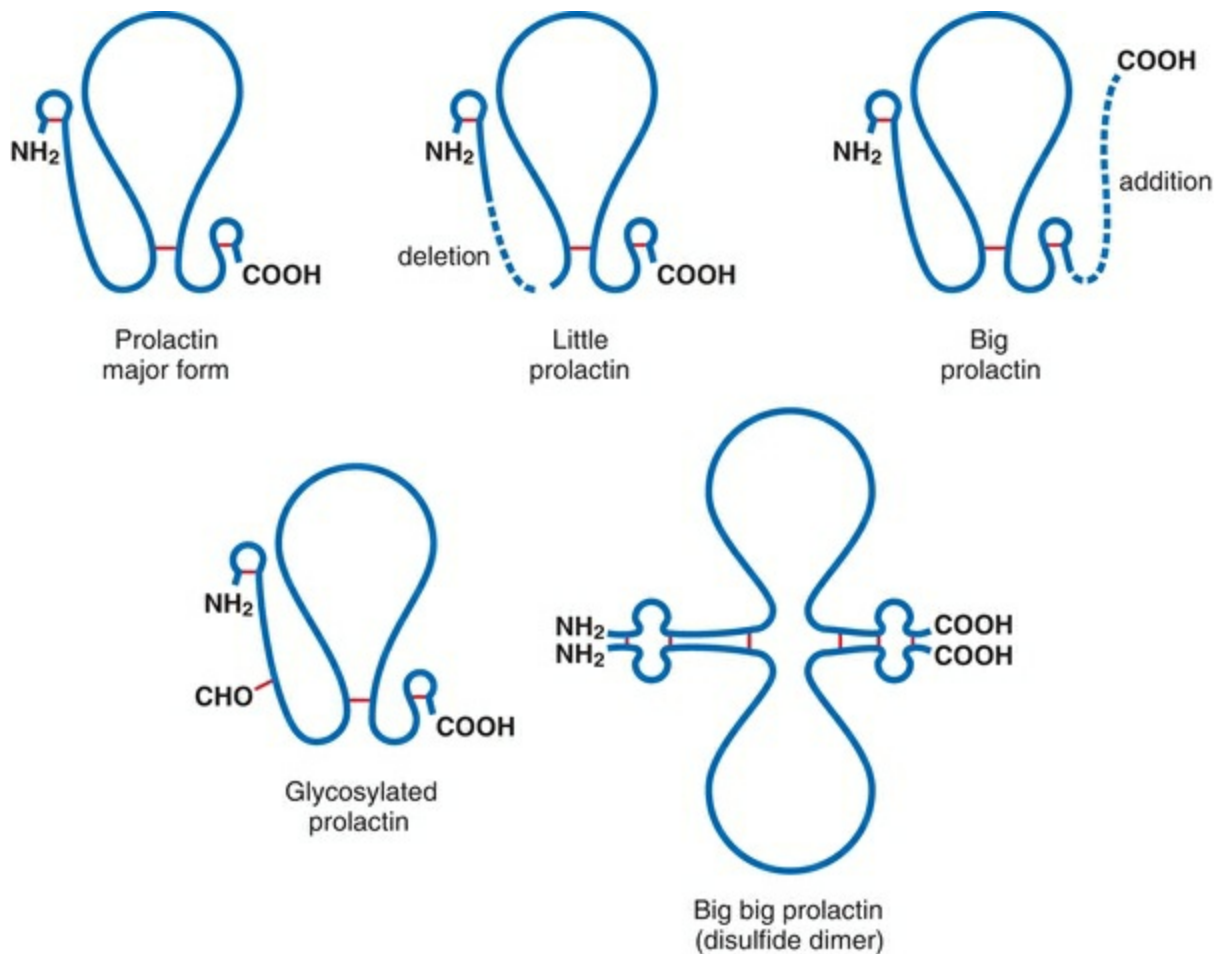
In most mammalian species, prolactin is a single-chain polypeptide of 199 amino acids,

40% similar in structure to growth hormone and placental lactogen.<sup>227</sup> All three hormones are believed to have originated in a common ancestral protein about 400 million years ago. Many hormones, growth factors, and neurotransmitters affect the prolactin gene.

Simultaneous measurements of prolactin by both bioassay and immunoassay reveal discrepancies. At first, differences in prolactin were observed based on size, leading to the use of terms such as little, big, and, the wonderfully sophisticated term, big big prolactin. Further chemical studies have revealed structural modifications that include glycosylation, phosphorylation, and variations in binding and charge. This heterogeneity is the result of many influences at many levels: transcription, translation, and peripheral metabolism.<sup>228,229</sup>

Prolactin is encoded by a single gene on chromosome 6, producing a molecule that in its major form is maintained in three loops by disulfide bonds.<sup>227</sup> Most, if not all, variants of prolactin are the result of posttranslational modifications (**Figure 1.33**). The predominant form, little prolactin, results from the proteolytic deletion of amino acids. Big prolactin has little biologic activity and does not cross-react with antibodies to the predominant form of prolactin. The so-called big big variants of prolactin are due to separate molecules of prolactin binding to each other, either noncovalently or by interchain disulfide bonding. Some of the apparently larger forms of prolactin are prolactin molecules complexed to binding proteins. High levels of relatively inactive prolactin in the absence of a tumor can be due to the creation of macromolecules of prolactin by antiprolactin autoantibodies.<sup>230,231</sup> Overall, the presence of big prolactins accounts for somewhere between 10% and 25% of the hyperprolactinemia reported by commercial assays<sup>232</sup>.





**FIGURE 1.33**

Other variations of prolactin exist. Enzymatic cleavage of the prolactin molecule yields fragments that may be capable of biologic activity. Prolactin that has been glycosylated continues to exert activity; differences in the carbohydrate moieties can produce differences in biologic activity and immunoreactivity. However, the nonglycosylated form of prolactin is the predominant form of prolactin secreted into the circulation.<sup>233</sup> Modification of prolactin also includes phosphorylation, deamidation, and sulfation.

The prolactin receptor is encoded by a gene on chromosome 5 that is near the gene for the growth hormone receptor. However, there is evidence for more than one receptor, depending on the site of action (e.g., decidua and placenta).<sup>234</sup> The prolactin receptor belongs to the receptor family that includes many cytokines and some growth factors, supporting a dual role for prolactin as a classic hormone and as a cytokine. The prolactin signal is mediated through a cytoplasmic tyrosine kinase pathway.

**At any one point of time, the bioactivity (e.g., galactorrhea) and the immunoreactivity (circulating level by immunoassay) of prolactin represent the cumulative effect of the family of structural variants. Remember, immunoassays do**

**not always reflect the biologic situation (e.g., a normal prolactin level in a woman with galactorrhea).**

# Up- and Down-Regulation of Receptors

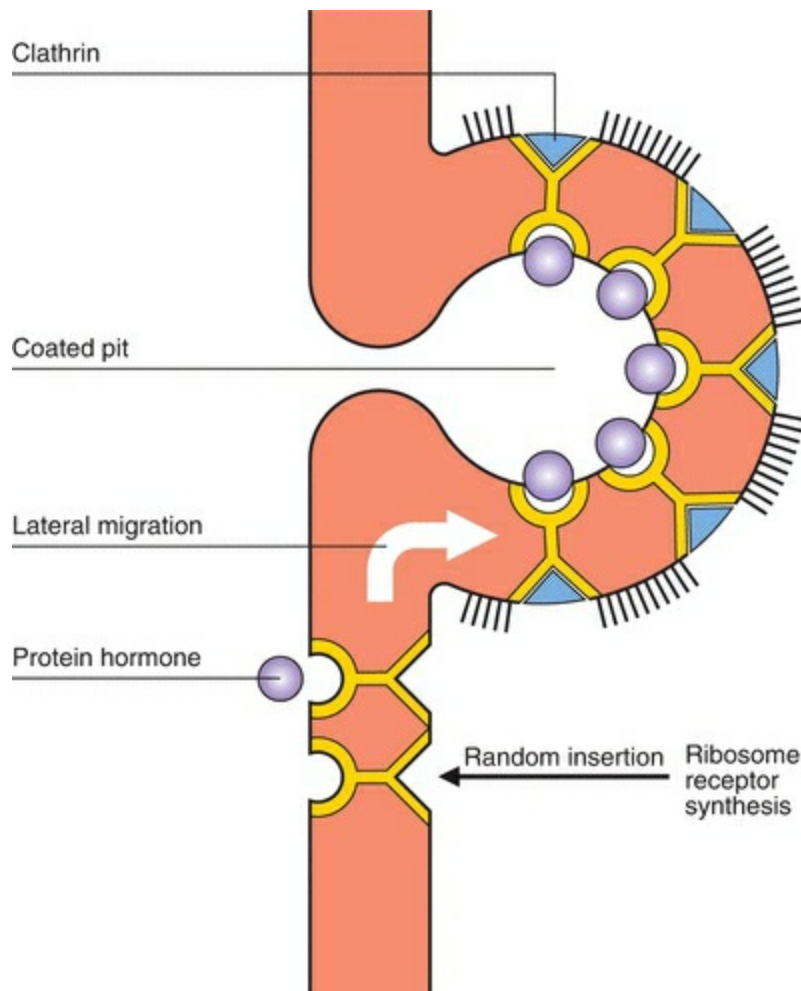
Positive or negative modulation of receptors by homologous hormones is known as up- and down-regulation. Little is known regarding the mechanism of up-regulation; however, hormones such as prolactin and GnRH can increase the cell membrane concentrations of their own receptors.

Theoretically, deactivation of the hormone-receptor complex could be accomplished by dissociation of the complex or loss of receptors from the cell, either by shedding (externally) or by internalization of the receptors into the cell. It is the process of **internalization** that is the major biologic mechanism by which polypeptide hormones down-regulate their own receptors and thus limit hormonal activity. As a general rule, an excess concentration of a tropic hormone, such as LH or GnRH, will stimulate the process of internalization, leading to a loss of receptors in the cell membrane and a decrease in biologic response. We now understand that the principal reason for the episodic (pulsatile) secretion of hormones is to avoid down-regulation and to maintain, if not up-regulate, its receptors. The pulse frequency is a key factor, therefore, in regulating receptor number. This concept underlies the pharmacology of GnRH agonist action. Chemical alteration of the GnRH molecule has produced both pharmacologic agonists and antagonists. GnRH is a decapeptide; antagonists have substitutions at multiple positions, while agonists have substitutions at the 6 or 10 positions. The GnRH agonist molecules first stimulate the pituitary gland to secrete gonadotropins; then, because of the constant stimulation, down-regulation and desensitization of the cell membrane receptors occur, and gonadotropin secretion is literally turned off. The GnRH antagonist molecules bind to the cell membrane receptor and fail to transmit a message and thus are competitive inhibitors. Various GnRH agonists and antagonists are used to treat endometriosis, uterine leiomyomas, and precocious puberty and also are key components of most controlled ovarian hyperstimulation protocols used for in vitro fertilization (see [Chapter 28](#) for more details).

It is believed that receptors are randomly inserted into the cell membrane after intracellular synthesis. The receptor may be viewed as having three important segments: an external binding site that is specific for a polypeptide hormone, the transmembrane region, and an internal site that plays a role in the process of internalization. When the receptor is bound to a polypeptide hormone and when high concentrations of the hormone are present in the circulation, the hormone-receptor complex moves through the cell membrane in a process called lateral migration. Lateral migration carries the complex to a specialized region of the cell membrane, **the coated pit**. Each cell in target tissues contains from 500 to 1,500 coated pits. Lateral migration, thus, concentrates hormone-receptor complexes in the coated pit (**clustering**), allowing

increased internalization of the complex via the special mechanism of **receptor-mediated endocytosis**.<sup>235</sup> The time course for this process (minutes rather than seconds) is too slow to explain the immediate hormone-induced responses, but other cellular events may be mediated by this mechanism that circumvents the intracellular messenger, cyclic AMP.

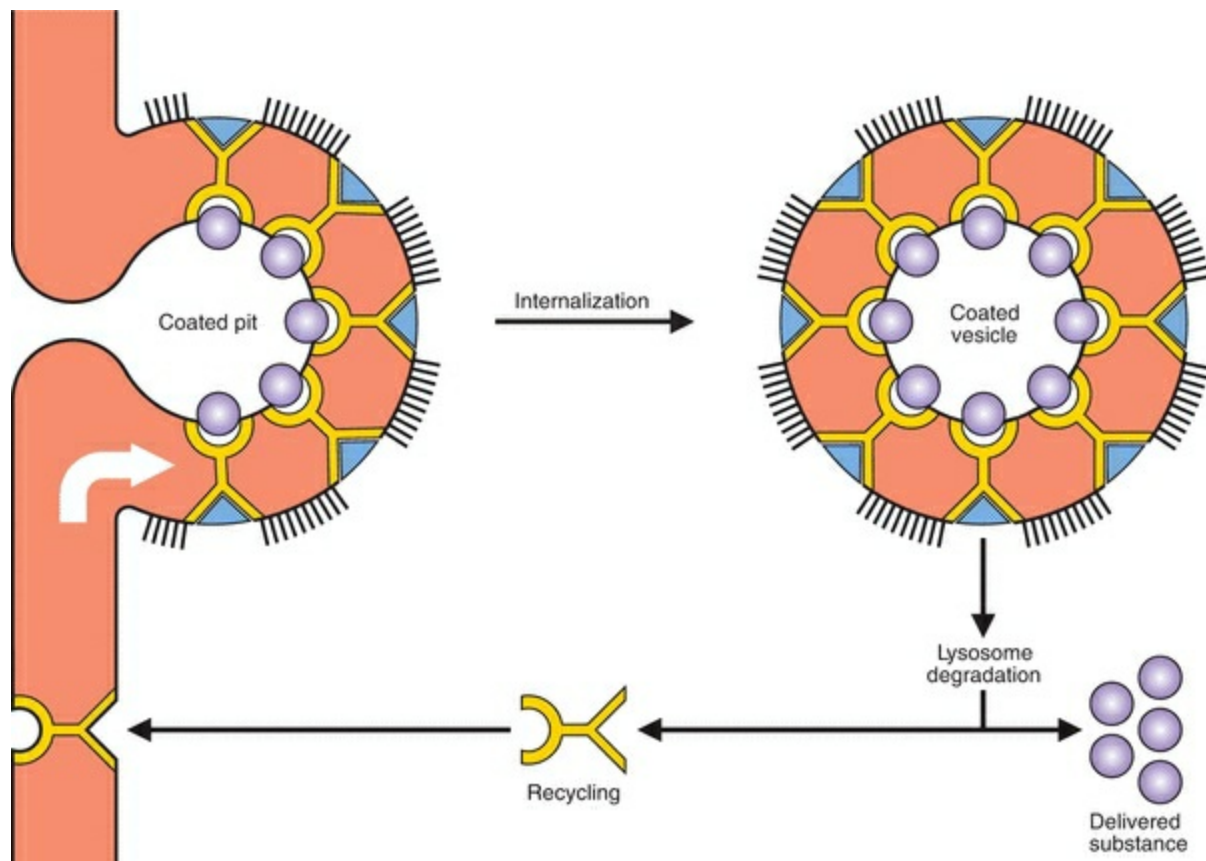
The coated pit is a lipid vesicle hanging on a basket of specific proteins, called **clathrins** (from the Latin “clathra” meaning “lattice”). The unit is a network of hexagons and pentagons, thus looking like a soccer ball (**Figure 1.34**). The internal margin of the pit has a brush border, hence the name coated pit. The clathrin protein network serves to localize the hormone-receptor complexes by binding to the internal binding site on the receptor.



**FIGURE 1.34**

When fully occupied, the coated pit invaginates, pinches off, and enters the cell as a coated vesicle also called a **receptosome** (**Figure 1.35**). The coated vesicle is

delivered to the lysosomes in which the structure then undergoes degradation, releasing the substance (e.g., a polypeptide hormone) and the receptor. The receptor may be recycled; that is, it may be reinserted into the cell membrane and used again. On the other hand, the receptor and the hormone may be metabolized, thus decreasing that hormone's biologic activity. The internalized hormones may also mediate biologic response by influencing cellular organelles such as the Golgi apparatus, the endoplasmic reticulum, and even the nucleus. For example, nuclear membranes from human ovaries bind hCG and LH, and there follows an enzyme response that is involved in the transfer of mRNA from nucleus to the cytoplasm.<sup>236</sup>



**FIGURE 1.35**

A similar process, called **potocytosis**, utilizes cholesterol-rich membrane invaginations called **caveolae** (far fewer in number and smaller in structure than the clathrin-coated pits) for the internalization of small molecules and ions.<sup>237</sup> This is another method of intracellular signaling in response to hormones, and many proteins involved in cell signaling have been detected in caveolae, for example, G proteins, kinases, and growth factor receptors. Caveolin is the major protein structural component of caveolae. Nitric oxide, the important mediator of vascular events, resides in caveolae and is regulated

by tyrosine phosphorylation and interaction with caveolin.<sup>238,239</sup> Caveolae also facilitate endocytosis and exocytosis of substances, by the recycling of caveolin between the cell surface and the Golgi network.<sup>240</sup>

Besides down-regulation of polypeptide hormone receptors, the process of internalization can be utilized for other cellular metabolic events, including the transfer into the cell of vital substances such as iron or vitamins. Indeed, this is the basic mechanism for transporting large molecules across the cell membrane into the interior.

Cell membrane receptors can be randomly distributed in the cell membrane and transmit information to modify cell behavior.<sup>241</sup> For these receptors, internalization is a method for down-regulation by degradation in lysosomes. Because of this degradation, recycling is usually not a feature of this class of receptors. Hormones that utilize this category of receptors include FSH, LH, hCG, GnRH, TSH, TRH, and insulin. For these hormones, the coated pit can be viewed as a trap to immobilize hormone-receptor complexes. The fate of the hormone, however, can vary from tissue to tissue. In some target tissues, hCG is internalized and the hCG-receptor complex is transferred intact from the coated vesicle into the lysosomes for dissociation and degradation. In other tissues, especially the placenta, it is thought that the hCG-receptor complex is recycled back to the cell surface as a means of transporting hCG across the placenta into both maternal and fetal circulations.<sup>242</sup>

Cell membrane receptors, located in the coated pits, when bound to ligands lead to internalization, thus providing the cell with required factors, the removal of noxious agents from the biologic fluid bathing the cell, or the transfer of substances through the cell (transendocytosis). These receptors are spared from degradation and can be recycled. Examples of this category include LDLs, which supply cholesterol to steroid-producing cells; cobalamin and transferrin, which supply vitamin B12 and iron, respectively; and the transfer of immunoglobulins across the placenta to provide fetal immunity.

A closer look at LDL and its receptor is informative because it is the prototype for this system. The LDL particle is a sphere. It contains in its center about 1,500 molecules of cholesterol that are attached as esters to fatty acids. This core is contained by a bilayer lipid membrane. Protein-binding proteins (the apoproteins) project on the surface of this membrane, and it is these proteins that the receptor must recognize.

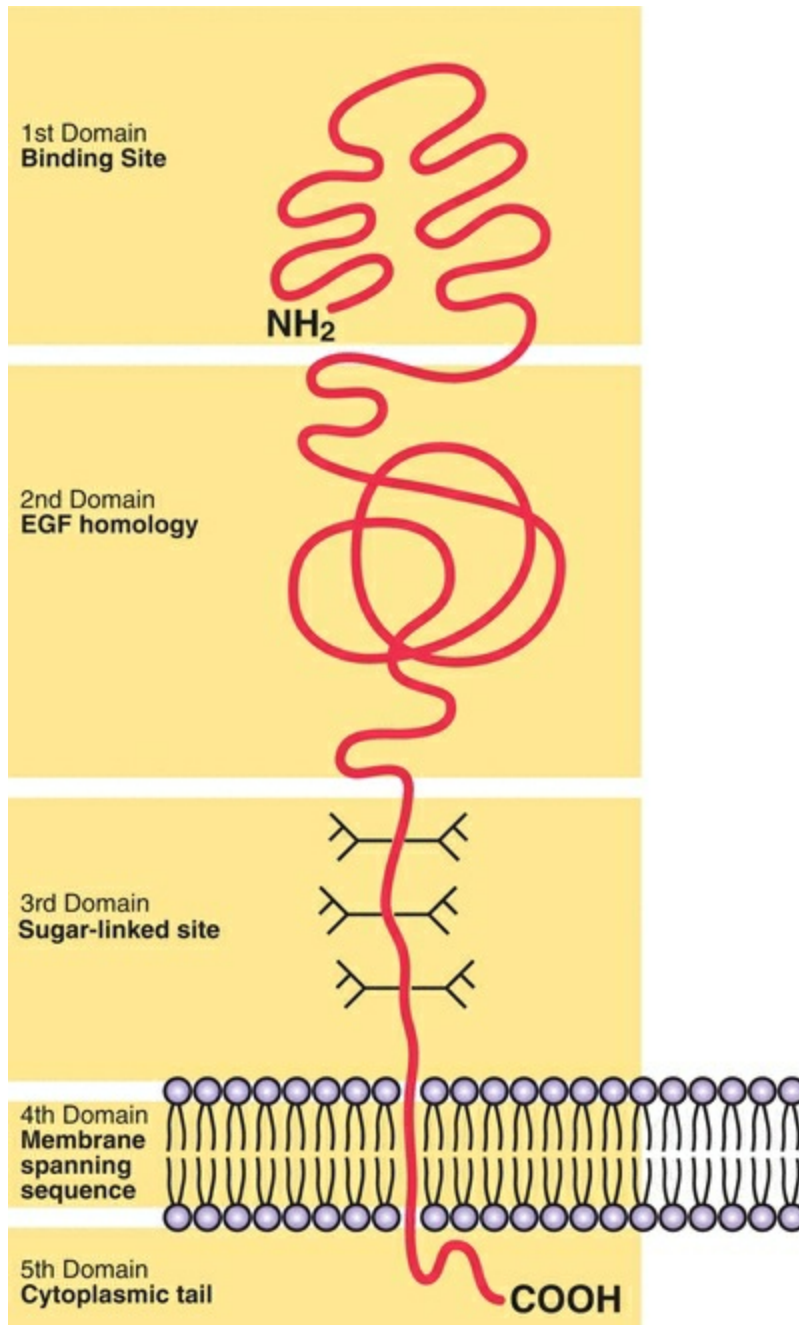
Remember, this is an important story, because all cells that produce steroids must use cholesterol as the basic building block. Such cells cannot synthesize enough cholesterol and therefore must bring cholesterol into the cell from the bloodstream. LDL is the principal messenger delivering the cholesterol. Experimental evidence, however, indicates that HDL cholesterol as well as LDL can provide cholesterol to steroid-producing cells.<sup>243</sup> Indeed, human ovarian granulosa cells use HDL cholesterol in a

system that differs from the LDL cholesterol pathway: the lipoproteins are not internalized, but, rather, the cholesteryl esters are extracted from the lipoproteins at the cell surface and then transferred into the cell.<sup>244</sup>

Different cell surface receptors and proteins contain similar structural parts.<sup>245</sup> For example, the receptor for LDL contains a region that is homologous to the precursor of EGF and another region that is homologous to a component of complement. The LDL receptor is a “mosaic protein.” There are regions of proteins derived from the exons of different gene families. This is an example of a protein that evolved as a new combination of preexisting functional units of other proteins.

The LDL receptor is synthesized as a precursor of 860 amino acids. The precursor includes 21 amino acids that constitute a hydrophobic signal sequence that is cleaved prior to its insertion into the cell surface. This signal sequence presumably directs the protein where to go in the cell. **This leaves an 839-amino acid protein that has five recognizable domains:**

- 1. NH<sub>2</sub> terminal of 292 amino acids, composed of a sequence of 40 amino acids repeated with some variation seven times. This domain is the binding site for LDL and is located on the external surface of the cell membrane.**
- 2. Approximately 400 amino acids 35% homologous to EGF precursor.**
- 3. The sugar-linked site.**
- 4. 22 hydrophobic amino acids that cross the cell membrane. Deletion of the transmembrane signal sequence (found in a naturally occurring mutation) results in an LDL receptor that is secreted from the cell instead of being inserted into the membrane.**
- 5. Cytoplasmic tail of 50 amino acids that is located internally and serves to cluster LDL receptors in coated pits (Figure 1.36).**



**FIGURE 1.36**

When the coated pit is fully occupied with LDL, a coated vesicle is delivered into the cell in the process called endocytosis. The vesicle moves to the Golgi system and then is routed by an unknown mechanism (although a similar coated pit system in the Golgi appears to be involved) to the lysosomes in which the structure undergoes degradation, releasing cholesterol esters and the receptor. The receptor can be recycled or degraded. The intracellular level of free cholesterol influences the following important activities: the rate-limiting enzyme for cholesterol synthesis, the reesterification of excess cholesterol for storage as lipid droplets, and the synthesis of LDL receptors. The



cholesterol derived from the LDL transport process can have any one of the following fates: utilization in the mitochondria for steroidogenesis, reesterification for storage, use in membrane structures, or excretion.<sup>246</sup> Excretion (release of free cholesterol into the circulation by means of the HDL mechanism) involves the cell surface caveolae.<sup>237,240</sup> Thus, entry is via coated pits (endocytosis) and efflux from endoplasmic reticulum to the cell membrane is via caveolae (exocytosis).

Synthesis and insertion of new LDL receptors are a function of LH in the gonads and ACTH in the adrenal. This process is relatively fast. It has been calculated that the coated pit system turns over an amount of cell surface equivalent to the total amount of plasma membrane every 30–90 minutes.<sup>246</sup> The LDL receptor makes one round trip every 10 minutes during its 20-hour life span for a total of several hundred trips.<sup>247</sup> Genetic defects in receptors for LDL lead to a failure in internalization and hyperlipidemia

## Key Points: Down-Regulation

Down-regulation is a decrease in response in the presence of continuous stimulation. It can involve any of the following mechanisms:

- Desensitization by autophosphorylation of the cytoplasmic segment of the receptor
- Loss of receptors by internalization, a relatively slow mechanism
- Uncoupling of the regulatory and catalytic subunits of the adenylate cyclase enzyme
- Alterations in key intracellular regulatory proteins

# Regulation of Tropic Hormone Action

One way in which tropic hormone action is regulated is via stimulating and inhibiting actions at the adenylate cyclase level through coupling. LH stimulates steroidogenesis in the corpus luteum and works through the coupling of stimulatory regulatory units to the catalytic units of adenylate cyclase. Prostaglandin  $F_{2a}$  is directly luteolytic, inhibiting luteal steroidogenesis through a mechanism that follows binding to specific receptors. This luteolytic action may be exerted via an inhibitory regulatory unit that leads to uncoupling with the catalytic unit, thus interfering with gonadotropin action.

Increasing concentrations of tropic hormones, such as gonadotropins, are directly associated with desensitization of adenylate cyclase independent of the internalization of receptors. Desensitization is a rapid, acute change without loss of receptors in contrast to the slower process of internalization and true receptor loss. The desensitization process after prolonged agonist exposure involves receptor phosphorylation (which uncouples the receptor from the G protein). The LH/hCG receptor, a member of the G protein family, undergoes desensitization/uncoupling in response to LH or hCG in a process that involves phosphorylation of the C-terminal cytoplasmic tail of the receptor.<sup>248,249</sup> Decreased gonadotropin secretion in the presence of prolonged continuous GnRH stimulation is a desensitization response that can occur followed by recovery within the time frame of a normal endogenous GnRH secretory pulse.<sup>250</sup>

Desensitization can also follow enzymatic alterations that affect the key intracellular proteins that regulate steroidogenesis. Activation of the mitogen-activated protein kinase (MAPK) system increases levels of SF-1, which in turn attenuates StAR expression, which is essential for the transport of cholesterol in gonadal cells producing steroids.<sup>251</sup>

# REFERENCES

1. **Ryan KJ**, Biological aromatization of steroids, *J Biol Chem* 234:268, 1959.
2. **Ryan KJ, Smith OW**, Biogenesis of steroid hormones in the human ovary, *Recent Prog Horm Res* 21:367, 1965.
3. **Miller WL**, Mitochondrial specificity of the early steps in steroidogenesis, *J Steroid Biochem Mol Biol* 55:607, 1995.
4. **Stocco DM, Clark BJ**, Regulation of the acute production of steroids in steroidogenic cells, *Endocr Rev* 17:221, 1996.
5. **Miller WL**, Steroidogenic enzymes, In: **Flück CE, Miller WL**, eds. *Disorders of the Human Adrenal Cortex*, Vol. 13, Karger, Basel, 2008, p. 1.
6. **Kim CJ, Lin L, Huang N, Quigley CA, AvRuskin TW, Achermann JC, Miller WL**, Severe combined adrenal and gonadal deficiency caused by novel mutations in the cholesterol side chain cleavage enzyme, P450<sub>scc</sub>, *J Clin Endocrinol Metab* 93:696, 2008.
7. **Liscum L, Dahl NK**, Intracellular cholesterol transport, *J Lipid Res* 33:1239, 1992.
8. **Reaven E, Tsai L, Azhar S**, Cholesterol uptake by the “selective” pathway of ovarian granulosa cells: early intracellular events, *J Lipid Res* 36:1602, 1995.
9. **Clark BJ, Wells J, King SR, Stocco DM**, The purification, cloning, and expression of a novel LH-induced mitochondrial protein in MA-10 mouse Leydig tumor cells: characterization of the steroidogenic acute regulatory protein (StAR), *J Biol Chem* 269:28314, 1994.
10. **Clark BJ, Soo SC, Caron KM, Ikeda Y, Parker KL, Stocco DM**, Hormonal and developmental regulation of the steroidogenic acute regulatory (StAR) protein, *Mol Endocrinol* 9:1346, 1995.
11. **Manna PR, Wang XJ, Stocco DM**, Involvement of multiple transcription factors in the regulation of steroidogenic acute regulatory protein gene expression, *Steroids* 68:1125, 2003.
12. **Miller WL**, StAR search—what we know about how the steroidogenic acute regulatory protein mediates mitochondrial cholesterol import, *Mol Endocrinol* 21:589, 2007.
13. **Bose M, Whittal RM, Miller WL, Bose HS**, Steroidogenic activity of StAR requires contact with mitochondrial VDAC1 and phosphate carrier protein, *J Biol Chem* 283:8837, 2008.
14. **Lin D, Sugawara T, Strauss JF III, Clark BJ, Stocco DM, Saenger P, Rogol A, Miller WL**, Role of steroidogenic acute regulatory protein in adrenal and gonadal steroidogenesis, *Science* 267:1828, 1995.
15. **Tee M, Lin D, Sugawara T, Holt JA, Guiguen Y, Buckingham B, Strauss JF III, Miller WL**, T-A transversion 11 bp from a splice acceptor site in the human gene for steroidogenic acute regulatory protein causes congenital lipid adrenal hyperplasia, *Hum Mol Genet* 4:2299, 1995.
16. **Bose H, Pescovitz OH, Miller WL**, Spontaneous feminization in a 46,XX female patient with congenital lipid adrenal hyperplasia due to a homozygous frameshift mutation in the steroidogenic acute regulatory protein, *J Clin Endocrinol Metab* 82:1511, 1997.
17. **Tee MK, Dong Q, Miller WL**, Pathways leading to phosphorylation of P450<sub>c17</sub> and to the posttranslational regulation of androgen biosynthesis, *Endocrinology* 149:2667, 2008.
18. **Simpson ER, Mahendroo MS, Means GD, Kilgore MW, Hinshelwood MM, Graham-Lorence S, Amarneh B, Ito Y, Fisher CR, Michael MD, Mendelson CR, Bulun SE**, Aromatase cytochrome P450, the enzyme responsible for estrogen biosynthesis, *Endocr Rev* 15:342, 1994.
19. **Simpson ER, Misso M, Hewitt KN, Hill RA, Boon WC, Jones ME, Kovacic A, Zhou J, Clyne CD**, Estrogen—the good, the bad, and the unexpected, *Endocr Rev* 26:322, 2005.
20. **Jones MEE, Boon WC, McInnes K, Maffei L, Carani C, Simpson ER**, Recognizing rare disorders: aromatase deficiency, *Nat Clin Pract Endocrinol Metab* 3:414, 2007.
21. **Sebastian S, Bulun SE**, A highly complex organization of the regulatory region of the human CYP19 (aromatase) gene revealed by the human genome project, *J Clin Endocrinol Metab* 86:4600, 2001.
22. **Labrie F, Luu-The V, Lin S-X, Simard J, Labrie C**, Role of 17 $\beta$ -hydroxysteroid dehydrogenases in sex steroid formation in peripheral intracrine tissues, *Trends Endocrinol Metab* 11:421, 2000.

23. **Kirschner MA, Samojlik E, Drejda M, Szmal E, Schneider G, Ertel N**, Androgen-estrogen metabolism in women with upper body versus lower body obesity, *J Clin Endocrinol Metab* 70:473, 1990.
24. **Siitari PK, MacDonald PC**, Role of extraglandular estrogen in human endocrinology, In: Geyer SR, Astwood EB, Greep RO, eds. *Handbook of Physiology, Section 7, Endocrinology*, American Physiology Society, Washington, DC, 1973, p. 615.
25. **Silva PD, Gentzschin EEK, Lobo RA**, Androstenedione may be a more important precursor of tissue dihydrotestosterone than testosterone in women, *Fertil Steril* 48:419, 1987.
26. **Horton R**, Dihydrotestosterone is a peripheral paracrine hormone, *J Androl* 13:23, 1992.
27. **Russell DW, Wilson JD**, Steroid 5 alpha-reductase: two genes/two enzymes, *Annu Rev Biochem* 63:25, 1994.
28. **Mooradian AD, Morley JE, Korenman SG**, Biological actions of androgens, *Endocr Rev* 8:1, 1987.
29. **Preziosi P, Barrett-Connor E, Papoz L, Roger M, Saint-Paul M, Nahoul K, Simon D**, Interrelation between plasma sex hormone-binding globulin and plasma insulin in healthy adult women: the Telecom study, *J Clin Endocrinol Metab* 76:283, 1993.
30. **Tsai EC, Matsumoto AM, Fujimoto WY, Boyko EJ**, Association of bioavailable, free, and total testosterone with insulin resistance: influence of sex hormone-binding globulin and body fat, *Diabetes Care* 27:861, 2004.
31. **Hajamor S, Despres JP, Couillard C, Lemieux S, Tremblay A, Prud'homme D, Tchernof A**, Relationship between sex hormone-binding globulin levels and features of the metabolic syndrome, *Metabolism* 52:724, 2003.
32. **Peiris AN, Sothmann MS, Aiman EJ, Kissebah AH**, The relationship of insulin to sex hormone binding globulin: role of adiposity, *Fertil Steril* 52:69, 1989.
33. **Bérubé D, Séralini GE, Gagné R, Hammond GL**, Localization of the human sex hormone-binding globulin gene (SHBG) to the short arm of chromosome 17 (17p12-13), *Cytogenet Cell Genet* 54:65, 1990.
34. **Hammond GL, Underhill DA, Rykse HM, Smith CL**, The human sex hormone-binding globulin gene contains exons for androgen-binding protein and two other testicular messenger RNAs, *Mol Endocrinol* 3:1869, 1989.
35. **Hammond GL, Bocchinfuso WP**, Sex hormone-binding globulin: gene organization and structure/function analyses, *Horm Res* 45:197, 1996.
36. **Rosner W**, The functions of corticosteroid-binding globulin and sex hormone-binding globulin: recent advances, *Endocr Rev* 11:80, 1990.
37. **Rosner W, Hryb DJ, Khan MS, Nakhia AM, Romas NA**, Sex hormone-binding globulin mediates steroid hormone signal transduction at the plasma membrane, *J Steroid Biochem Mol Biol* 69:481, 1999.
38. **Hammes A, Andreassen TK, Spoelgen R, Raila J, Hubner N, Schulz H, Metzger J, Schweigert FJ, Lupp PB, Nykjaer A, Willnow TE**, Role of endocytosis in cellular uptake of sex steroids, *Cell* 122:751, 2005.
39. **Webb P, Lopez GN, Greene GL, Baxter JD, Kushner PJ**, The limits of the cellular capacity to mediate an estrogen response, *Mol Endocrinol* 6:157, 1992.
40. **Gerace L**, Molecular trafficking across the nuclear pore complex, *Curr Opin Cell Biol* 4:637, 1992.
41. **Katzenellenbogen BS**, Biology and receptor interactions of estriol and estriol derivatives in vitro and in vivo, *J Steroid Biochem* 20:1033, 1984.
42. **Brown TJ, Scherz B, Hochberg RB, MacLusky NJ**, Regulation of estrogen receptor concentrations in the rat brain: effects of sustained androgen and estrogen exposure, *Neuroendocrinology* 63:53, 1996.
43. **Cárdenas H, Pope WF**, Attenuation of estrogenic effects by dihydrotestosterone in the pig uterus is associated with downregulation of the estrogen receptors, *Biol Reprod* 70:297, 2004.
44. **Evans RM**, The steroid and thyroid hormone receptor family, *Science* 240:889, 1988.
45. **Moore JT, Collins JL, Pearce KH**, The nuclear receptor superfamily and drug discovery, *ChemMedChem* 1:504, 2006.
46. **Thornton JW**, Evolution of vertebrate steroid receptors from an ancestral estrogen receptor by ligand exploitation and serial genome expansions, *Proc Natl Acad Sci U S A* 98:5671, 2001.

47. **Thornton JW, Need E, Crews D**, Resurrecting the ancestral steroid receptor: ancient origin of estrogen signaling, *Science* 301:1714, 2003.
48. **Kuiper G, Enmark E, Pelto-Huikko M, Nilsson S, Gustafsson J**, Cloning of a novel estrogen receptor expressed in rat prostate and ovary, *Proc Natl Acad Sci U S A* 93:5925, 1996.
49. **Mosselman S, Polman J, Dijkema R**, ER- $\beta$ : identification and characterization of a novel human estrogen receptor, *FEBS Lett* 392:49, 1996.
50. **Jensen EV, Jacobson HI**, Basic guides to the mechanism of estrogen action, *Recent Prog Horm Res* 18:387, 1962.
51. **Green S, Walter P, Greene G, Krust A, Goffin C, Jensen E, Scrace G, Walterfield M, Chambon P**, Cloning of the human oestrogen receptor cDNA, *J Steroid Biochem* 24:77, 1986.
52. **Greene GL, Gilna P, Walterfield M, Baker A, Hort Y, Shine J**, Sequence and expression of human estrogen receptor cDNA, *Science* 231:1150, 1986.
53. **Parker MG**, Structure and function of the oestrogen receptor, *J Neuroendocrinol* 5:223, 1993.
54. **Enmark E, Pelto-Huikko M, Grandien K, Lagercrantz S, Lagercrantz J, Fried G, Nordenskjöld M, Gustafsson J-Å**, Human estrogen receptor beta-gene structure, chromosomal localization, and expression pattern, *J Clin Endocrinol Metab* 82:4258, 1997.
55. **Zhao C, Dahlman-Wright K, Gustafsson J-A**, Estrogen receptor beta: an overview and update, *Nucl Recept Signal* 6:e003, 2008.
56. **Teyssier C, Bianco S, Lanvin O, Vanacker JM**, The orphan receptor ERR $\alpha$  interferes with steroid signaling, *Nucleic Acids Res* 36:5350, 2008.
57. **Jin KS, Park JK, Yoon J, Rho Y, Kim J-K, Kim EE, Ree M**, Small-angle X-ray scattering studies on structures of an estrogen-related receptor a ligand binding domain and its complexes with ligands and coactivators, *J Phys Chem* 112:9603, 2008.
58. **Lu NZ, Wardell SE, Burnstein KL, Defranco D, Fuller PJ, Giguere V, Hochberg RB, McKay L, Renoir JM, Weigel NL, Wilson EM, McDonnell DP, Cidlowski JA**, International Union of Pharmacology. LXV. The pharmacology and classification of the nuclear receptor superfamily: glucocorticoid, mineralocorticoid, progesterone, and androgen receptors, *Pharmacol Rev* 58:782, 2006.
59. **Weihua Z, Andersson S, Cheng G, Simpson ER, Warner M, Gustafsson J-Å**, Update on estrogen signaling, *FEBS Lett* 546:17, 2003.
60. **Morani A, Warner M, Gustafsson J-A**, Biological functions and clinical implications of oestrogen receptors alfa and beta in epithelial tissues, *J Intern Med* 264:128, 2008.
61. **Kuiper GG, Carlsson B, Grandien K, Enmark E, Häggblad J, Nilsson S, Gustafsson J**, Comparison of the ligand binding specificity and transcript tissue distribution of estrogen receptors alpha and beta, *Endocrinology* 138:863, 1997.
62. **Teutsch G, Nique F, Lemoine G, Fouchoux F, Cérède E, Gofflo D, Philibert D**, General structure-activity correlations of antihormones, *Ann N Y Acad Sci* 761:5, 1995.
63. **Montano MM, Müller V, Trobaugh A, Katzenellenbogen BS**, The carboxy-terminal F domain of the human estrogen receptor: role in the transcriptional activity of the receptor and the effectiveness of antiestrogens as estrogen antagonists, *Mol Endocrinol* 9:814, 1995.
64. **Reid G, Hübner MR, Métivier R, Brand H, Denger S, Manu D, Beaudouin J, Ellenberg J, Gannon F**, Cyclic, proteasome-mediated turnover of unliganded and liganded ER $\alpha$  on responsive promoters is an integral feature of estrogen signaling, *Mol Cell* 11:695, 2003.
65. **Parker MG**, Structure and function of estrogen receptors, *Vitam Horm* 51:267, 1995.
66. **Wurtz JM, Bourguet W, Renaud JP, Vivat V, Chambon P, Moras D, Gronemeyer H**, A canonical structure for the ligand-binding domain of nuclear receptors, *Nat Struct Biol* 3:87, 1996.
67. **Brzozowski AM, Pike ACW, Dauter Z, Hubbard RE, Bonn T, Engström O, Öhman L, Greene GL, Gustafsson JÅ, Carlquist M**, Molecular basis of agonism and antagonism in the oestrogen receptor, *Nature* 389:753, 1997.
68. **Tanenbaum DM, Wang Y, Williams SP, Sigler PB**, Crystallographic comparison of the estrogen and progesterone receptors ligand binding domains, *Proc Natl Acad Sci U S A* 95:5998, 1998.

69. **Melamed M, Castroño E, Notides AC, Sasson S**, Molecular and kinetic basis for the mixed agonist/antagonist activity of estriol, *Mol Endocrinol* 11:1868, 1997.
70. **Zhuang Y, Katzenellenbogen BS, Shapiro DJ**, Estrogen receptor mutants which do not bind 17 $\beta$ -estradiol dimerize and bind to the estrogen response element in vivo, *Mol Endocrinol* 9:457, 1995.
71. **Freedman LP**, Anatomy of the steroid receptor zinc finger region, *Endocr Rev* 13:129, 1992.
72. **O'Malley BW, Tsai M-J**, Molecular pathways of steroid receptor action, *Biol Reprod* 46:163, 1992.
73. **Beato M, Sánchez-Pacheco A**, Interaction of steroid hormone receptors with the transcription initiation complex, *Endocr Rev* 17:587, 1996.
74. **Halachmi S, Marden E, Martin G, MacKay H, Abbondanza C, Brown M**, Estrogen receptor-associated proteins: possible mediators of hormone-induced transcription, *Science* 264:1455, 1994.
75. **Cavaillès V, Dauvois S, L'Horset F, Lopez G, Hoare S, Kushner PJ, Parker MG**, Nuclear factor RIP140 modulates transcriptional activation by the estrogen receptor, *EMBO J* 14:3741, 1995.
76. **Horwitz KB, Jackson TA, Bain DL, Richer JK, Takimoto GS, Tung L**, Nuclear receptor coactivators and corepressors, *Mol Endocrinol* 10:1167, 1996.
77. **Shibata H, Spencer TE, Onate SA, Jenster G, Tsai SY, Tsai MJ, O'Malley BW**, Role of co-activators and co-repressors in the mechanism of steroid/thyroid receptor action, *Recent Prog Horm Res* 52:141, 1997.
78. **McKenna NJ, O'Malley BW**, Combinational control of gene expression by nuclear receptors and coregulators, *Cell* 108:465, 2002.
79. **Lonard DM, O'Malley BW**, Nuclear receptor coregulators: judges, juries, and executioners of cellular regulation, *Mol Cell* 7:691, 2007.
80. **Ciocca DR, Vargas Roid LM**, Estrogen receptors in human nontarget tissues: biological and clinical implications, *Endocr Rev* 16:35, 1995.
81. **O'Malley BW, Qin J, Lanz RB**, Cracking the coregulator codes, *Curr Opin Cell Biol* 20:310, 2008.
82. **Lonard DM, Lanz RB, O'Malley BW**, Nuclear receptor coregulators and human disease, *Endocr Rev* 28:575, 2007.
83. **Hyder SM, Shipley GL, Stancel GM**, Estrogen action in target cells: selective requirements for activation of different hormone response elements, *Mol Cell Endocrinol* 112:35, 1995.
84. **Shang Y, Hu X, DiRenzo J, Lazar MA, Brown M**, Cofactor dynamics and sufficiency in estrogen receptor-regulated transcription, *Cell* 103:843, 2000.
85. **O'Malley BW, Schrader WT, Mani S, Smith C, Weigel NL, Conneely OM, Clark JH**, An alternative ligand-independent pathway for activation of steroid receptors, *Recent Prog Horm Res* 50:333, 1995.
86. **Sinkevicius KW, Burdette JE, Woloszyn K, Hewitt SC, Hamilton K, Sugg SL, Temple KA, Wondisford FE, Korach KS, Woodruff TK, Greene GL**, An estrogen receptor-a knock-in mutation provides evidence of ligand-independent signaling and allows modulation of ligand-induced pathways in vivo, *Endocrinology* 149:2970, 2008.
87. **Lindzey J, Korach KS**, Developmental and physiological effects of estrogen receptor gene disruption in mice, *Trends Endocrinol Metab* 8:137, 1997.
88. **Harris HA**, Estrogen receptor-beta: recent lessons from in vivo studies, *Mol Endocrinol* 21:1, 2007.
89. **Hewitt SC, Korach KS**, Oestrogen receptor knockout mice: roles for oestrogen receptors alpha and beta in reproductive tissues, *Reproduction* 125:143, 2003.
90. **Brandenberger AW, Tee MK, Lee JY, Chao V, Jaffe RB**, Tissue distribution of estrogen receptors alpha (ER-alpha) and beta (ER-beta) mRNA in the midgestational human fetus, *J Clin Endocrinol Metab* 82:3509, 1997.
91. **Britt KL, Findlay JK**, Estrogen actions in the ovary revisited, *J Endocrinol* 175:269, 2002.
92. **Österlund MK, Gustafsson J-Å, Keller E, Hurd YL**, Estrogen receptor beta (ER $\beta$ ) messenger ribonucleic acid (mRNA) expression within the human forebrain: distinct distribution pattern to ER $\alpha$  mRNA, *J Clin Endocrinol Metab* 85:3840, 2000.
93. **Zhu Y, Bian Z, Karas RH, Bao L, Cox D, Hodgins J, Shaul PW, Thorén P, Smithies O, Gustafsson J-Å, Mendelsohn ME**, Abnormal vascular function and hypertension in mice deficient in estrogen receptor beta, *Science* 295:505, 2002.

94. **Shughrue PJ, Lane MV, Merchenthaler I**, Comparative distribution of estrogen receptor-alpha and -beta mRNA in the rat central nervous system, *J Comp Neurol* 388:507, 1997.
95. **Lindberg MK, Movérare S, Skrtic S, Gao H, Dahlman-Wright K, Gustafsson J-Å, Ohlsson C**, Estrogen receptor (ER)- $\beta$  reduces ER $\alpha$ -regulated gene transcription, supporting a “Ying Yang” relationship between ER $\alpha$  and ER $\beta$  in mice, *Mol Endocrinol* 17:203, 2003.
96. **Speirs V, Carder PJ, Lane S, Dodwell D, Lansdown MR, Hanby AM**, Oestrogen receptor  $\beta$ : what it means for patients with breast cancer, *Lancet Oncol* 5:174, 2004.
97. **Gougelet A, Mueller SO, Korach KS, Renoir J-M**, Oestrogen receptors pathways to oestrogen responsive elements: the transactivation function-1 acts as the keystone of oestrogen receptor (ER) $\beta$ -mediated transcriptional repression of ER $\alpha$ , *J Steroid Biochem Mol Biol* 104:110, 2007.
98. **Bardin A, Boule N, Lazennec G, Vignon F, Pujol P**, Loss of ER  $\beta$  expression as a common step in estrogen-dependent tumor progression, *Endocr Relat Cancer* 11:537, 2004.
99. **Paech K, Webb P, Kuiper GG, Nilsson S, Gustafsson J, Kushner PJ, Scanlan TS**, Differential ligand activation of estrogen receptors ER $\alpha$  and ER $\beta$  at AP1 sites, *Science* 277:1508, 1997.
100. **Liu Y, Gao H, Marstrand TT, Ström A, Valen E, Sandelin A, Gustafsson J-A, Dahlman-Wright K**, The genome landscape of ER $\alpha$ - and ER $\beta$ -binding DNA regions, *Proc Natl Acad Sci U S A* 105:2604, 2008.
101. **Madak-Erdogan Z, Kieser KJ, Kim SH, Komm B, Katzenellenbogen JA, Katzenellenbogen BS**, Nuclear and extranuclear pathway inputs in the regulation of global gene expression by estrogen receptors, *Mol Endocrinol* 22:2116, 2008.
102. **Russell KS, Haynes MP, Sinha D, Clerisma E, Bender JR**, Human vascular endothelial cells contain membrane binding sites for estradiol, which mediate intracellular signaling, *Proc Natl Acad Sci U S A* 97:5930, 2000.
103. **Kim KH, Moriarty K, Bender JR**, Vascular cell signaling by membrane estrogen receptors, *Steroids* 73:864, 2008.
104. **Prossnitz ER, Arterburn JB, Smith HO, Oprea TI, Sklar LA, Hathaway HJ**, Estrogen signaling through the transmembrane G protein-coupled receptor GPR30, *Annu Rev Physiol* 70:165, 2008.
105. **McDevitt MA, Glidewell-Kenney C, Jimenez MA, Ahearn PC, Weiss JE, Jameson JL, Levine JE**, New insights into the classical and non-classical actions of estrogen: evidence from estrogen receptor knock-out and knock-in mice, *Mol Cell Endocrinol* 290:24, 2008.
106. **Horwitz KB, Tung L, Takimoto GS**, Novel mechanisms of antiprogestin action, *J Steroid Biochem Mol Biol* 53:9, 1995.
107. **Lange CA, Sartorius CA, Abdel-Hafiz H, Spillman MA, Horwitz KB, Jacobsen BM**, Progesterone receptor action: translating studies in breast cancer models to clinical insights, *Adv Exp Med Biol* 630:94, 2008.
108. **Read LD, Katzenellenbogen BS**, Characterization and regulation of estrogen and progesterone receptors in breast cancer, *Cancer Treat Res* 61:277, 1992.
109. **Kastner P, Krust A, Turcotte B, Stropp U, Tora L, Gronemeyer H, Chambon P**, Two distinct estrogen-regulated promoters generate transcripts encoding the two functionally different human progesterone receptor forms A and B, *EMBO J* 9:1603, 1990.
110. **Wen DXL, Xu Y-F, Mais DE, Goldman ME, McDonnell DP**, The A and B isoforms of the human progesterone receptor operate through distinct signaling pathways within target cells, *Mol Cell Biol* 14:8356, 1994.
111. **Sartorius CA, Melville MY, Hovland AR, Tung L, Takimoto GS, Horwitz KB**, A third transactivation function (AF-3) of human progesterone receptors located in the unique N-terminal segment of the B-isoform, *Mol Endocrinol* 8:1347, 1994.
112. **Vegeto E, Allan GF, Schrader WT, Tsai MJ, McDonnell DP, O'Malley BW**, Mechanism of RU486 antagonism is dependent on the conformation of the carboxyl-terminal tail of the human progesterone receptor, *Cell* 69:703, 1992.
113. **Williams SP, Sigler PB**, Atomic structure of progesterone complexed with its receptor, *Nature* 393:392, 1998.
114. **Feil PD, Clarke CL, Satyaswaroop PG**, Progesterin-mediated changes in progesterone receptor forms in the normal human endometrium, *Endocrinology* 123:2506, 1988.

115. **McDonnell DP, Goldman ME**, RU486 exerts antiestrogenic activities through a novel progesterone receptor A form-mediated mechanism, *J Biol Chem* 269:11945, 1994.
116. **McDonnell DP, Shahbaz MM, Vegeto E, O'Malley BW**, The human progesterone receptor A-form functions as a transcriptional modulator of mineralocorticoid receptor transcriptional activity, *J Steroid Biochem Mol Biol* 48: 425, 1994.
117. **Richer JK, Jacobsen BM, Manning NG, Abel MG, Wolf DM, Horwitz KB**, Differential gene regulation by the two progesterone receptor isoforms in human breast cancer cells, *J Biol Chem* 277:5209, 2002.
118. **Giangrande PH, Kimbrel EA, Edwards DP, McDonnell DP**, The opposing transcriptional activities of the two isoforms of the human progesterone receptor are due to differential cofactor binding, *Mol Cell Biol* 20:3102, 2000.
119. **Gellersen B, Fernandes MS, Brosens JJ**, Non-genomic progesterone actions in female reproduction, *Hum Reprod Update* 19:119, 2009.
120. **Grazzini E, Guillon G, Mouillac B, Zingg HH**, Inhibition of oxytocin receptor function by direct binding of progesterone, *Nature* 392:509, 1998.
121. **Conneely OM, Mulac-Jericevic B, Lydon JP, De Mayo FG**, Reproductive functions of the progesterone receptor isoforms: lessons from knock-out mice, *Mol Cell Endocrinol* 179:97, 2001.
122. **Brinton RD, Thompson RF, Foy MR, Baudry M, Wang J, Finch CE, Morgan TE, Pike CJ, Mack WJ, Stanczyk FZ, Nilsen J**, Progesterone receptors: form and function in brain, *Front Neuroendocrinol* 29:313, 2008.
123. **Peluso JJ, Romak J, Liu X**, Progesterone receptor membrane component-1 (PGRMC1) is the mediator of progesterone's antiapoptotic action in spontaneously immortalized granulosa cells as revealed by PGRMC1 small interfering ribonucleic acid treatment and functional analysis of PGRMC1 mutations, *Endocrinology* 149:534, 2008.
124. **Tindall DJ, Chang CH, Lobl TJ, Cunningham GR**, Androgen antagonists in androgen target tissues, *Pharmacol Ther* 24:367, 1984.
125. **Wilson CM, McPhaul MJ**, A and B forms of the androgen receptor are present in human genital skin fibroblasts, *Proc Natl Acad Sci U S A* 91:1234, 1994.
126. **Jenster G, van der Korput JA, Trapman J, Brinkmann AO**, Functional domains of the human androgen receptor, *Mol Cell Endocrinol* 86:187, 1992.
127. **Gottlieb B, Trifiro M, Lumbroso R, Pinsky L**, The androgen receptor gene mutations database, *Nucleic Acids Res* 25:158, 1997.
128. **Vilchis F, Ramos L, Kofman-Alfaro S, Zenteno JC, Mendez JP, Chavez B**, Extreme androgen resistance in a kindred with a novel insertion/deletion mutation in exon 5 of the androgen receptor gene, *J Hum Genet* 48:346, 2003.
129. **Lubahn DB, Joseph DR, Sullivan PM, Willard HF, French FS, Wilson EM**, Cloning of human androgen receptor complementary DNA and localization to the X chromosome, *Science* 240:327, 1988.
130. **Griffin JE, Wilson JD**, Disorders of androgen receptor function, *Ann N Y Acad Sci* 438:61, 1984.
131. **Zuccarello D, Ferlin A, Vinanzi C, Prana E, Garolla A, Callewaert L, Claessens F, Brinkmann AO, Foresta C**, Detailed functional studies on androgen receptor mild mutations demonstrate their association with male infertility, *Clin Endocrinol (Oxf)* 68:580, 2008.
132. **MacLean HE, Warne GL, Zajac JD**, Spinal and bulbar muscular atrophy: androgen receptor dysfunction caused by a trinucleotide repeat expansion, *J Neurol Sci* 135:149, 1996.
133. **Kirkland JL, Murthy L, Stancel GM**, Progesterone inhibits the estrogen-induced expression of c-fos messenger ribonucleic acid in the uterus, *Endocrinology* 130:3223, 1992.
134. **Tseng L, Lui HC**, Stimulation of arylsulfotransferase activity by progestins in human endometrium in vitro, *J Clin Endocrinol Metab* 53:418, 1981.
135. **Soto A, Sonnenschein C**, The two faces of Janus: sex steroids as mediators of both cell proliferation and cell death, *J Natl Cancer Inst* 93:1673, 2001.
136. **Jordan VC**, Antiestrogens and selective estrogen receptor modulators as multifunctional medicines. 2. Clinical considerations and new agents, *J Med Chem* 46:1081, 2003.



137. **Early Breast Cancer Trialists' Collaborative Group**, Effects of chemotherapy and hormonal therapy for early breast cancer on recurrence and 15-year survival: an overview of randomised trials, *Lancet* 365:1687, 2005.
138. **Early Breast Cancer Trialists' Collaborative Group**, Adjuvant chemotherapy in oestrogen-receptor-poor breast cancer: patient-level meta analysis of randomised trials, *Lancet* 371:29, 2008.
139. **Clarke MJ**, Tamoxifen for early breast cancer, *Cochrane Database Syst Rev* (8):CD000486, 2008.
140. **Helgason S, Wilking N, Carlstrom K, Damber MG, von Schoultz B**, A comparative study of the estrogenic effects of tamoxifen and 17 $\beta$ -estradiol in postmenopausal women, *J Clin Endocrinol Metab* 54:404, 1982.
141. **Saphner T, Tormey DC, Gray R**, Venous and arterial thrombosis in patients who received adjuvant therapy for breast cancer, *J Clin Oncol* 9:286, 1991.
142. **Fisher B, Dignam J, Bryant J, DeCillis A, Wickerham DL, Wolmark N, Costantino J, Redmond C, Fisher ER, Bowman DM, Deschênes L, Dimitrov NV, Margolese RG, Robidoux A, Shibata H, Terz J, Paterson AHG, Feldman MI, Farrar W, Evans J, Lickley HL**, Five versus more than five years of tamoxifen therapy for breast cancer patients with negative lymph nodes and estrogen receptor-positive tumors, *J Natl Cancer Inst* 88:1529, 1996.
143. **Fisher B, Costantino JP, Wickerham DL, Redmond CK, Kavanah M, Cronin WM, Vogel V, Robidoux A, Dimitrov N, Atkins J, Daly M, Wieand S, Tan-Chiu E, Ford L, Wolmark N; National Surgical Adjuvant Breast and Bowel Project investigators**, Tamoxifen for prevention of breast cancer: report of the National Surgical Adjuvant Breast and Bowel Project P-1 Study, *J Natl Cancer Inst* 90:1371, 1998.
144. **Kedar RP, Bourne TH, Powles TJ, Collins WP, Ashley SE, Cosgrove DO, Campbell S**, Effects of tamoxifen on uterus and ovaries of postmenopausal women in a randomized breast cancer prevention trial, *Lancet* 343:1318, 1994.
145. **Fisher B, Costantino JP, Redmond CK, Fisher ER, Wickerham DL, Cronin WM; NSABP contributors**, Endometrial cancer in tamoxifen-treated breast cancer patients: findings from the National Surgical Adjuvant Breast and Bowel Project (NSABP) B-14, *J Natl Cancer Inst* 86:527, 1994.
146. **Landel CC, Kushner PJ, Greene GL**, The interaction of human estrogen receptor with DNA is modulated by receptor-associated proteins, *Mol Endocrinol* 8:1407, 1994.
147. **Berry M, Metzger D, Chambon P**, Role of the two activating domains of the oestrogen receptor in the cell type and promoter context dependent agonistic activity of the antioestrogen 4-hydroxytamoxifen, *EMBO J* 9:2811, 1990.
148. **Katzenellenbogen BS, Montano MM, Le Goff P, Schodin DJ, Kraus WL, Bhardwaj B, Fujimoto N**, Antiestrogens: mechanisms and actions in target cells, *J Steroid Biochem Mol Biol* 53:387, 1995.
149. **Tzukerman MT, Esty A, Santisomere D, Danielian P, Parker MG, Stein RB, Pike JW, McDonnell DP**, Human estrogen receptor transactivational capacity is determined by both cellular and promoter context and mediated by two functionally distinct intramolecular regions, *Mol Endocrinol* 8:21, 1994.
150. **Murphy LC**, Antiestrogen action and growth factor regulation, *Breast Cancer Res Treat* 31:61, 1994.
151. **Colletta AA, Benson JR, Baum M**, Alternative mechanisms of action of anti-oestrogens, *Breast Cancer Res Treat* 31:5, 1994.
152. **Stewart HJ, Forrest AP, Everington D, McDonald CC, Dewar JA, Hawkins RA, Prescott RJ, George WD; Behalf of the Scottish Cancer Trials Breast Group**, Randomized comparison of 5 years of adjuvant tamoxifen with continuous therapy for operable breast cancer, *Br J Cancer* 74:297, 1996.
153. **Fisher B, Dignam J, Bryant J, Wolmark N**, Five versus more than five years of tamoxifen for lymph node-negative breast cancer: updated findings from the National Surgical Adjuvant Breast and Bowel Project B-14 randomized trial, *J Natl Cancer Inst* 93:684, 2001.
154. **Horwitz KB**, Hormone-resistant breast cancer or "feeding the hand that bites you", *Prog Clin Biol Res* 387:29, 1994.
155. **Encarnación CA, Ciocca DR, McGuire WL, Clark GM, Fuqua SAW, Osborne CK**, Measurement of steroid hormone receptors in breast cancer patients on tamoxifen, *Breast Cancer Res Treat* 26:237, 1993.

156. **Robertson JFR**, Oestrogen receptor: a stable phenotype in breast cancer, *Br J Cancer* 73:5, 1996.
157. **Mahfoudi A, Roulet E, Dauvois S, Parker MG, Wahli W**, Specific mutations in the estrogen receptor change the properties of antiestrogens to full agonists, *Proc Natl Acad Sci U S A* 92:4206, 1995.
158. **Jeselson R, Buchwalter G, De Angelis C, Brown M, Schiff R**, ESR1 mutations—a mechanism for acquired endocrine resistance in breast cancer, *Nat Rev Clin Oncol* 12:573, 2015.
159. **Fujimoto N, Katzenellenbogen BS**, Alteration in the agonist/antagonist balance of antiestrogens by activation of protein kinase A signaling pathways in breast cancer cells: antiestrogen selectivity and promoter dependence, *Mol Endocrinol* 8:296, 1994.
160. **Pavlik EJ, Nelson K, Srinivasan S, Powell DE, Kenady DE, DePriest PD, Gallion HH, van Nagell JRJ**, Resistance to tamoxifen with persisting sensitivity to estrogen: possible mediation by excessive antiestrogen binding site activity, *Cancer* 52:4106, 1992.
161. **Berstein LM, Zheng H, Yue W, Wang J-P, Lykkesfeldt AE, Naftolin F, Harada N, Shanabrough M, Santen RJ**, New approaches to the understanding of tamoxifen action and resistance, *Endocr Relat Cancer* 10:267, 2003.
162. **Howell A**, The future of fulvestrant (“Faslodex”), *Cancer Treat Rev* 31:S260S33, 2005.
163. **Long X, Nephew KP**, Fulvestrant (ICI 182,780)-dependent interacting proteins mediate immobilization and degradation of estrogen receptor- $\alpha$ , *J Biol Chem* 281:9607, 2006.
164. **Wittmann BM, Sherk A, McDonnell DP**, Definition of functionally important mechanistic differences among selective estrogen receptor down-regulators, *Cancer Res* 67:9549, 2007.
165. **Gass EK, Leonhardt SA, Nordeen SK, Edwards DP**, The antagonists RU486 and ZK98299 stimulate progesterone receptor binding to deoxyribonucleic acid in vitro and in vivo, but have distinct effects on receptor conformation, *Endocrinology* 139:1905, 1998.
166. **Liu Z, Auboeuf D, Wong J, Chen JD, Tsai SY, Tsai MJ, O’Malley BW**, Coactivator/corepressor ratios modulate PR-mediated transcription by the selective receptor modulator RU486, *Proc Natl Acad Sci U S A* 99:7940, 2002.
167. **Allan GF, Leng X, Tsai S-T, Weigel NL, Edwards DP, Tsai MJ, O’Malley BW**, Hormone and antihormone induce distinct conformational changes which are central to steroid receptor activation, *J Biol Chem* 267:19513, 1992.
168. **Vegeto E, Shahbaz MM, Wen DX, Goldman ME, McDonnell DP, O’Malley BW**, Human progesterone receptor A form is a cell- and promoter-specific repressor of human progesterone B function, *Mol Endocrinol* 7:1244, 1993.
169. **Gilman AG**, Guanine nucleotide-binding regulatory proteins and dual control of adenylate cyclase, *J Clin Invest* 73:1, 1984.
170. **Neer EJ**, Heterotrimeric G proteins: organizers of transmembrane signals, *Cell* 80:249, 1995.
171. **Spiegel AM**, Genetic basis of endocrine disease. Mutations in G proteins and G protein-coupled receptors in endocrine disease, *J Clin Endocrinol Metab* 81:2434, 1996.
172. **Rodbell M**, The role of GTP-binding proteins in signal transduction: from the sublimely simple to the conceptually complex, *Curr Top Cell Regul* 32:1, 1992.
173. **Neubig RR**, Membrane organization in G-protein mechanisms, *FASEB J* 8:939, 1994.
174. **Cabrera-Vera TM, Vanhauwe J, Thomas TO, Medkova M, Preininger A, Mazzoni MR, Hamm HE**, Insights into G protein structure, function, and regulation, *Endocr Rev* 24:765, 2003.
175. **Fredriksson R, Schioth HB**, The repertoire of G-protein-coupled receptors in fully sequenced genomes, *Mol Pharmacol* 67:1414, 2005.
176. **Segaloff DL, Ascoli M**, The lutropin/choriogonadotropin receptor—4 years later, *Endocr Rev* 14:324, 1993.
177. **Alpaugh K, Indrapichate K, Abel JA, Rimerman R, Wimalasena J**, Purification and characterization of the human ovarian LH/hCG receptor and comparison of the properties of mammalian LH/hCG receptors, *Biochem Pharmacol* 40:2093, 1990.
178. **Minegishi T, Nakamura K, Takakura Y, Ibuki Y, Igarashi M**, Cloning and sequencing of human FSH receptor cDNA, *Biochem Biophys Res Commun* 175:1125, 1991.
179. **Simoni M, Gromoll J, Nieschlag E**, The follicle-stimulating hormone receptor: biochemistry, molecular

- biology, physiology, and pathophysiology, *Endocr Rev* 18:739, 1997.
180. **van Biesen T, Luttrell LM, Hawes BE, Lefkowitz RJ**, Mitogenic signaling via G protein-coupled receptors, *Endocr Rev* 17:698, 1996.
  181. **Weinstein LS, Yu S, Warner DR, Liu J**, Endocrine manifestations of stimulatory G protein  $\alpha$ -subunit mutations and the role of genomic imprinting, *Endocr Rev* 22:675, 2001.
  182. **Themmen APN**, An update of the pathophysiology of human gonadotropin subunit and receptor gene mutations and polymorphisms, *Reproduction* 130:263, 2005.
  183. **Lania AG, Mantovani G, Spada A**, Mechanisms of disease: mutations of G proteins and G-protein-coupled receptors in endocrine diseases, *Nat Clin Pract Endocrinol Metab* 2:681, 2006.
  184. **Loganzo F Jr, Fletcher PW**, Follicle-stimulating hormone increases guanine nucleotide-binding regulatory protein subunit  $\alpha$ -3 mRNA but decreases  $\alpha$ -1 and  $\alpha$ -2 mRNA in Sertoli cells, *Mol Endocrinol* 6:1259, 1992.
  185. **Piersma D, Verhoef-Post M, Berns EM, Themmen AP**, LH receptor gene mutations and polymorphisms: an overview, *Mol Cell Endocrinol* 260–262:282, 2007.
  186. **Roesler WJ, Vandenbark GR, Hanson RW**, Cyclic AMP and the induction of eukaryotic gene transcription, *J Biol Chem* 263:9063, 1988.
  187. **Sunahara RK, Dessauer CW, Gilman AG**, Complexity and diversity of mammalian adenylyl cyclases, *Annu Rev Pharmacol Toxicol* 36:461, 1996.
  188. **Kelly PA, Djiane J, Edery M**, Different forms of the prolactin receptor: insights into the mechanism of prolactin action, *Trends Endocrinol Metab* 3:54, 1992.
  189. **Rasmussen H**, The calcium messenger system, *N Engl J Med* 314:1164, 1986.
  190. **Tse A, Hille B**, GnRH-induced  $\text{Ca}^{2+}$  oscillations and rhythmic hyperpolarizations of pituitary gonadotropes, *Science* 255:462, 1992.
  191. **Giudice L**, The insulin-like growth factor system in normal and abnormal human ovarian follicle development, *Am J Med* 16:48S, 1995.
  192. **Matthews LS**, Activin receptors and cellular signaling by the receptor serine kinase family, *Endocr Rev* 15:310, 1994.
  193. **Voutilainen R, Franks S, Mason HD, Martikainen H**, Expression of insulin-like growth factor (IGF), IGF-binding protein, and IGF receptor messenger ribonucleic acids in normal and polycystic ovaries, *J Clin Endocrinol Metab* 81:1003, 1996.
  194. **Mohan S, Baylink DJ**, Editorial: insulin-like growth factor (IGF)-binding proteins in serum—do they have additional roles besides modulating the endocrine IGF actions? *J Clin Endocrinol Metab* 81:3817, 1996.
  195. **Luo X, Ikeda Y, Parker KL**, A cell-specific nuclear receptor is essential for adrenal and gonadal development and sexual differentiation, *Cell* 77:481, 1994.
  196. **Parker KL, Schimmer BP**, Steroidogenic factor 1: a key determinant of endocrine development and function, *Endocr Rev* 18:361, 1997.
  197. **Sugawara T, Holt JA, Kiriakidou M, Strauss JF III**, Steroidogenic factor 1-dependent promoter activity of the human steroidogenic acute regulatory protein (StAR) gene, *Biochemistry* 35:9052, 1996.
  198. **Pelusi C, Ikeda Y, Zubair M, Parker KL**, Impaired follicle development and infertility in female mice lacking Steroidogenic factor 1 in ovarian granulosa cells, *Biol Reprod* 79:1074, 2008.
  199. **Salvi R, Gomez F, Fiaux M, Schorderet T, Jameson JL, Achermann JC, Gaillard RC, Pralong FP**, Progressive onset of adrenal insufficiency and hypogonadism of pituitary origin caused by a complex genetic rearrangement within DAX-1, *J Clin Endocrinol Metab* 87:4094, 2002.
  200. **Burris TP, Guo W, McCabe ER**, The gene responsible for adrenal hypoplasia congenita, DAX-1, encodes a nuclear hormone receptor that defines a new class within the superfamily, *Recent Prog Horm Res* 51:241, 1996.
  201. **Lambert A, Talbot JA, Anobile CJ, Robertson WR**, Gonadotrophin heterogeneity and biopotency: implications for assisted reproduction, *Mol Hum Reprod* 4:619, 1998.
  202. **Beitins IZ, Padmanabhan V**, Bioactive follicle-stimulating hormone, *Trends Endocrinol Metab* 2:145, 1991.
  203. **Wide L, Bakos O**, More basic forms of both follicle-stimulating hormone and luteinizing hormone in serum at midcycle compared with the follicular or luteal phase, *J Clin Endocrinol Metab* 76:885, 1993.

204. **Lapthorn AJ, Harris DC, Littlejohn A, Lustbader JW, Canfield RE, Machin KJ, Mogan FJ, Isaacs NW**, Crystal structure of human chorionic gonadotropin, *Nature* 369:455, 1994.
205. **Weiss J, Axelrod L, Whitcomb RW, Harris PE, Crowley WF, Jameson JL**, Hypogonadism caused by a single amino acid substitution in the b-subunit of luteinizing hormone, *N Engl J Med* 326:179, 1992.
206. **Huth JR, Mountjoy K, Peini F, Ruddon RW**, Intracellular folding pathway of human chorionic gonadotropin beta subunit, *J Biol Chem* 267:8870, 1992.
207. **Gharib SD, Wierman ME, Shupnik MA, Chin WW**, Molecular biology of the pituitary gonadotropins, *Endocr Rev* 11:177, 1990.
208. **Albanese C, Colin IM, Crowley WF, Ito M, Pestell RG, Weiss J, Jameson JL**, The gonadotropin genes: evolution of distinct mechanisms for hormonal control, *Recent Prog Horm Res* 51:23, 1996.
209. **Weiss J, Guendner MJ, Halvorson LM, Jameson JL**, Transcriptional activation of the follicle-stimulating hormone beta-subunit gene by activin, *Endocrinology* 136:1885, 1995.
210. **Su P, Shafiee-Kermani F, Gore J, Jia J, Wu JC, Miller WL**, Expression and regulation of the beta-subunit of ovine follicle-stimulating hormone relies heavily on a promoter sequence likely to bind Smad-associated proteins, *Endocrinology* 148:4500, 2007.
211. **Besecke LM, Guendner MJ, Schneyer AL, Bauer-Dantoin AC, Jameson JL, Weiss J**, Gonadotropin-releasing hormone regulates follicle-stimulating hormone- $\beta$  gene expression through an activin/follistatin autocrine or paracrine loop, *Endocrinology* 137:3667, 1996.
212. **Bilezikjian LM, Corrigan AZ, Blount AL, Vale WW**, Pituitary follistatin and inhibin subunit messenger ribonucleic acid levels are differentially regulated by local and hormonal factors, *Endocrinology* 137:4277, 1996.
213. **Jameson JL, Hollenberg AN**, Regulation of chorionic gonadotropin gene expression, *Endocr Rev* 14:203, 1993.
214. **Henke A, Gromoll J**, New insights into the evolution of chorionic gonadotrophin, *Mol Cell Endocrinol* 291:11, 2008.
215. **Nilsson C, Pettersson K, Millar RP, Coerver KA, Matzuk MM, Huhtaniemi IT; International Collaborative Research Group**, Worldwide frequency of a common genetic variant of luteinizing hormone: an international collaborative research, *Fertil Steril* 67:998, 1997.
216. **Huhtaniemi I, Jiang M, Nilsson C, Pettersson K**, Mutations and polymorphisms in gonadotrophin genes, *Mol Cell Endocrinol* 151:89, 1999.
217. **Hwang J, Menon KMJ**, Spatial relationships of the human chorionic gonadotropin (hCG) subunits in the assembly of the hCG-receptor complex in the luteinized rat ovary, *Proc Natl Acad Sci U S A* 81:4667, 1984.
218. **Merz WE, Dorner M**, Studies on structure-function relationships of human choriogonadotropins with C-terminally shortened alpha subunits. I. Receptor binding and immunologic properties, *Biochem Biophys Acta* 844:62, 1985.
219. **Grinberg M, Nakav S, Pen S, Dantes A, Braw-Tal R, Amsterdam A, Ben-Menaheem D**, The configuration of the alpha and beta subunit domains in single-chain bovine LH analogs influences the secretion and steroidogenic response, *Mol Cell Endocrinol* 283:83, 2008.
220. **Wide L, Naessen T**,  $17\beta$ -oestradiol counteracts the formation of the more acidic isoforms of follicle-stimulating hormone and luteinizing hormone after menopause, *Clin Endocrinol (Oxf)* 40:783, 1994.
221. **Wide L, Albertsson-Wikland K, Phillips DJ**, More basic isoforms of serum gonadotropins during gonadotropin-releasing hormone agonist therapy in pubertal children, *J Clin Endocrinol Metab* 81:216, 1996.
222. **Mason M, Fonseca E, Ruiz JE, Moran C, Zarate A**, Distribution of follicle-stimulating-hormone and luteinizing-hormone isoforms in sera from women with primary ovarian failure compared with that of normal reproductive and postmenopausal women, *Fertil Steril* 58:60, 1992.
223. **Anobile CJ, Talbot JA, McCann SJ, Padmanabhan V, Robertson WR**, Glycoform composition of serum gonadotrophins through the normal menstrual cycle and in the post-menopausal state, *Mol Hum Reprod* 4:631, 1998.
224. **De Leeuw R, Mulders J, Voortman G, Rombout F, Damm J, Kloosterboer L**, Structure-function relationship of recombinant follicle stimulating hormone (Puregon), *Mol Hum Reprod* 2:361, 1996.
225. **Combarnous Y**, Molecular basis of the specificity of binding of glycoprotein hormones to their receptors,

Endocr Rev 13:670, 1992.

226. **Galway AB, Hsueh AJ, Keene JL, Yamoto M, Fauser BC, Boime I**, In vitro and in vivo bioactivity of recombinant human follicle-stimulating hormone and partially deglycosylated variants secreted by transfected eukaryotic cell lines, *Endocrinology* 127:93, 1990.
227. **Bole-Feysot C, Goffin V, Edery M, Binart N, Kelly PA**, Prolactin (PRL) and its receptor: actions, signal transduction pathways and phenotypes observed in PRL receptor knockout mice, *Endocr Rev* 19:225, 1998.
228. **Sinha YN**, Structural variants of prolactin: occurrence and physiological significance, *Endocr Rev* 16:354, 1995.
229. **Ben-Jonathan N, Mershon JL, Allen DL, Steinmetz RW**, Extrapituitary prolactin: distribution, regulation, functions, and clinical aspects, *Endocr Rev* 17:639, 1996.
230. **Hattori N, Ishihara T, Ikekubo K, Moridera K, Hino M, Kurahachi H**, Autoantibody to human prolactin in patients with idiopathic hyperprolactinemia, *J Clin Endocrinol Metab* 75:1226, 1992.
231. **Hattori N, Inagaki C**, Anti-prolactin (PRL) autoantibodies cause asymptomatic hyperprolactinemia: bioassay and clearance studies of PRL-immunoglobulin G complex, *J Clin Endocrinol Metab* 82:3107, 1997.
232. **Smith TP, Suliman AM, Fahie-Wilson MN, McKenna TJ**, Gross variability in the detection of prolactin in sera containing big big prolactin (macroprolactin) by commercial immunoassays, *J Clin Endocrinol Metab* 87:5410, 2002.
233. **Brue T, Caruso E, Morange I, Hoffmann T, Evrin M, Gunz G, Benkirane M, Jaquet P**, Immunoradiometric analysis of circulating human glycosylated and nonglycosylated prolactin forms: spontaneous and stimulated secretions, *J Clin Endocrinol Metab* 75:1338, 1992.
234. **Maaskant RA, Bogic LV, Gilger S, Kelly PA, Bryant-Greenwood GD**, The human prolactin receptor in the fetal membranes, decidua, and placenta, *J Clin Endocrinol Metab* 81:396, 1996.
235. **Goldstein JL, Anderson RGW, Brown MS**, Coated pits, coated vesicles, and receptor-mediated endocytosis, *Nature* 279:679, 1979.
236. **Toledo A, Ramani N, Rao CV**, Direct stimulation of nucleoside triphosphatase activity in human ovarian nuclear membranes by human chorionic gonadotropin, *J Clin Endocrinol Metab* 65:305, 1987.
237. **Smart EJ, Ying Y, Donzell WC, Anderson RGW**, A role for caveolin in transport of cholesterol from endoplasmic reticulum to plasma membrane, *J Biol Chem* 271:29427, 1996.
238. **García-Cardeña G, Fan R, Stern DF, Liu J, Sessa WC**, Endothelial nitric oxide synthase is regulated by tyrosine phosphorylation and interacts with caveolin-1, *J Biol Chem* 271:27237, 1996.
239. **Liu J, García-Cardeña G, Sessa WC**, Palmitoylation of endothelial nitric oxide synthase is necessary for optimal stimulated release of nitric oxide: implications for caveolae localization, *Biochemistry* 35:13277, 1996.
240. **Fielding PE, Giendling CJ**, Intracellular transport of low density lipoprotein derived free cholesterol begins at clathrin-coated pits and terminates at cell surface caveolae, *Biochem* 35:14932, 1996.
241. **Kaplan J**, Polypeptide-binding membrane receptors: analysis and classification, *Science* 212:14, 1981.
242. **Ascoli M**, Lysosomal accumulation of the hormone-receptor complex during receptor-mediated endocytosis of human chorionic gonadotropin, *J Cell Biol* 99:1242, 1984.
243. **Parinaud J, Perret B, Ribbes H, Chap H, Pontonnier G, Douste-Blazy L**, High density lipoprotein and low density lipoprotein utilization by human granulosa cells for progesterone synthesis in serum-free culture: respective contributions of free and esterified cholesterol, *J Clin Endocrinol Metab* 64:409, 1987.
244. **Azhar S, Tsai L, Medicherla S, Chandrasekher Y, Giudice L, Reaven E**, Human granulosa cells use high density lipoprotein cholesterol for steroidogenesis, *J Clin Endocrinol Metab* 83:983, 1998.
245. **Sudhof TC, Goldstein JL, Brown MS, Russell DW**, The LDL receptor gene: a mosaic of exons shared with different proteins, *Science* 228:815, 1985.
246. **Reinhart MP**, Intracellular sterol trafficking, *Experientia* 46:599, 1990.
247. **Brown MS, Goldstein JL**, A receptor-mediated pathway for cholesterol homeostasis, *Science* 232:34, 1986.
248. **Hipkin RW, Wang Z, Ascoli M**, Human chorionic gonadotropin (CG) — and phorbol ester-stimulated phosphorylation of the luteinizing hormone/CG receptor maps to serines 635, 639, 649, and 652 in the C-terminal cytoplasmic tail, *Mol Endocrinol* 9:151, 1995.
249. **Ferguson SS**, Evolving concepts in G protein-coupled receptor endocytosis: the role in receptor desensitization and signaling, *Pharmacol Rev* 53:1, 2001.

250. **Weiss J, Cote C, Jameson JL, Crowley WF Jr**, Homologous desensitization of gonadotropin-releasing hormone (GnRH)-stimulated luteinizing hormone secretion in vitro occurs within the duration of an endogenous GnRH pulse, *Endocrinology* 136:138, 1995.
251. **Dantes TK, Yao Z, Sorokina K, Kotsuji F, Seger R, Amsterdam A**, Down-regulation of steroidogenic response to gonadotropins in human and rat preovulatory granulosa cells involves mitogen-activated protein kinase activation and modulation of DAX-1 and steroidogenic factor-1, *J Clin Endocrinol Metab* 88:2288, 2003.

## The Ovary—Embryology and Development

The great names of early Western medicine were Hippocrates, Soranus, and Galen. Although Aristotle (384–322 B.C.) referred to castration as a common agricultural practice, it was Soranus who provided the first anatomic description of the ovaries. Soranus of Ephesus (a city founded by Greeks on the coast of what is now Turkey) lived from 98 to 138 A.D. and has often been referred to as the greatest gynecologist of antiquity.<sup>1</sup> He studied in Alexandria and practiced in Rome. His great text was lost for centuries and was not published until 1838.

Galen was born in 130 A.D. in Pergamum, a Greek city in eastern Turkey; studied in Alexandria; and became a famous practitioner and teacher of medicine also in Rome. He lived 70 years and wrote about 400 treatises, 83 of which are still in existence. Galen preserved in his own writings (in Greek) Aristotle's descriptions of reproduction. He was a true scholar and was regarded as the ultimate authority on anatomy and physiology until the 16th century.<sup>2</sup> It was Galen who established bleeding as the appropriate treatment for almost every disorder. Although in retrospect Galen's conclusions and teachings contained many errors, how many other individuals have been able to satisfy the needs of scholars and physicians for hundreds of years?

After Galen, no further thoughts or advances were recorded for well over 1,000 years as the dark weight of the medieval ages descended on Western civilization. During the medieval years, it was safe to copy Galen's works but literally dangerous to contribute anything original. Medieval scholars believed it was impossible to progress in knowledge beyond Galen. The doctrine according to Galen was not challenged until the introduction of printing made Galen's works available to scholars.

Although Leonardo da Vinci (1452–1519) drew accurately the anatomy of the uterus and the ovaries, the major advances in anatomic knowledge can be traced to the University of Padua, the famed Italian university where a succession of anatomists made important contributions.<sup>3</sup> It was Andreas Vesalius (1514–1564), who while still in his 20s, because of his own human dissections, realized that Galen described only animals. Appointed Professor of Surgery and Anatomy at the University of Padua at the age of 23, he published *De Humani Corporis Fabrica*, his authoritative, illustrated book on human anatomy, in 1543, at the age of 29. Vesalius was harshly attacked by the medical establishment, and 1 year after the publication of his book, he left Padua to become the court physician in Spain.

Vesalius was the first to describe ovarian follicles and probably the corpus luteum. Fallopius (1523–1562), remembered for his description of the fallopian tubes, was a pupil of Vesalius and then a successful and popular teacher of anatomy at Padua. Fabricius (Girolamo Fabrici d'Acquapendente, 1533–1619), a pupil of Fallopius, succeeded Fallopius as chair of anatomy at Padua and made major contributions to embryology. Studying an organ in birds and observing that it contained eggs, Fabricius called it the “ovary.” During this period of time, the ovaries came to be recognized as structures, but their function remained a mystery.

William Harvey published the first original English book on reproductive anatomy and physiology in 1651, at the age of 69, 35 years after his discovery of the circulation of blood. He obtained his medical education at the University of Padua, where he learned to describe accurately his own observations, a practice he was to continue and that culminated in his writings. Credited with the well-known “ex ovo omnia” (everything comes from the egg) statement, Harvey actually promoted and maintained the Aristotelian belief that the egg was a product of conception, a result of an interaction between semen and menstrual blood. This view was corrected by Bishop Niels Stensen of Denmark in 1667, and in 1672, at the age of 31, the Dutch physician Regnier de Graaf published his great work on the female reproductive organs, *De Mulierum Organis Generationi Inservientibus Tractatus Novus* (A New Treatise on the Female Reproductive Organs), that established the ovary as the source of the ovum.

Ovarian follicles had been described by Vesalius and Fallopius, but the impact of his publication earned de Graaf eternal recognition as the mature ovarian follicle became known as the graafian follicle, even though de Graaf believed that the whole follicle was the egg. de Graaf was the first to accurately describe the corpus luteum, although Marcello Malpighi, whose works were published posthumously in 1697, invented the name “corpus luteum.”

With the discovery of mammalian spermatozoa by van Leeuwenhoek in 1677, it became possible to speculate that fertilization resulted from the combination of a spermatozoon and the graafian follicle. It would be another 150 years before it was appreciated that the oocyte resides within the follicle (described in 1827 by Carl Ernst von Baer) and that there is a relationship between the ovaries and menstruation. The process of fertilization was described by Newport in 1853–1854, and Oscar Hertwig, studying sea urchins, reported in 1876 the penetration of a spermatozoon into an egg and chromosome reduction during meiosis, bringing to a close the era of descriptive anatomy of the ovary and marking the beginning of scientific explorations into physiology and endocrinology.



# THE HUMAN OVARY

---

The physiologic responsibilities of the ovary are the periodic release of gametes (eggs, oocytes) and the production of the steroid hormones estradiol and progesterone. Both activities are integrated in the continuous repetitive process of follicle maturation, ovulation, and corpus luteum formation and regression. The ovary, therefore, cannot be viewed as a relatively static endocrine organ whose size and function expand and contract, depending on the vigor of stimulating tropic hormones. Rather, the female gonad is a heterogeneous ever-changing tissue whose cyclicity is measured in weeks, rather than hours.

The ovary consists of three major portions: the outer cortex, the central medulla, and the rete ovarii (the hilum). The hilum is the point of attachment of the ovary to the mesovarium. It contains nerves, blood vessels, and hilus cells, which have the potential to become active in steroidogenesis or to form tumors. These cells are very similar to the testosterone-producing Leydig cells of the testes. The outermost portion of the cortex is called the tunica albuginea, topped on its surface by a single layer of cuboidal epithelium, referred to as the ovarian surface epithelium or the ovarian mesothelium (epithelial ovarian carcinomas account for 90% of human ovarian cancers). The oocytes, enclosed in complexes called follicles, are in the inner part of the cortex, embedded in stromal tissue. The stromal tissue is composed of connective tissue and interstitial cells, which are derived from mesenchymal cells, and have the ability to respond to luteinizing hormone (LH) or human chorionic gonadotropin (hCG) with androgen production. The central medullary area of the ovary is derived largely from mesonephric cells.

# THE FETAL OVARY

---

During fetal life, the development of the human ovary can be traced through four stages<sup>4,5</sup>: (1) the indifferent gonad stage, (2) the stage of differentiation, (3) the period of oogonial multiplication and oocyte formation, and finally, (4) the stage of follicle formation.

# The Indifferent Gonad Stage

At approximately 5 weeks of gestation, the paired gonads are structurally consolidated coelomic prominences overlying the mesonephros, forming the gonadal ridges. At this point, the gonad is morphologically indistinguishable as a primordial testis or ovary. The gonad is composed of primitive germ cells intermingled with coelomic surface epithelial cells and an inner core of medullary mesenchymal tissue. Just below this ridge lies the mesonephric duct. This indifferent stage lasts about 7–10 days. Together, the mesonephros and the genital ridge are called the urogenital ridge, indicating the close association of the urinary and reproductive systems.

The origin of the gonadal somatic cells is still not certain. The earliest recognizable gonad contains, besides the germ cells, somatic cells derived from at least three different tissues: coelomic epithelium, mesenchyme, and mesonephric tissue. In one early model, the gonad was believed to be formed by the invasion of the “germinal epithelium” into the underlying mesenchyme. The germinal epithelium is simply that part of the coelomic epithelium that gives rise to gonadal tissue. The invading cells were thought to form the primary sex cords that contain the germ cells surrounded by somatic cells (the cells destined to form the tissue that holds the germ cells). In a newer model, well-supported by experimental data, the somatic cells of the gonad are believed to arise from the mesonephros and not the coelomic epithelium.<sup>6,7,8</sup> Ultrastructural studies have even suggested that both coelomic epithelial and underlying mesonephric cells provide the somatic cells that are destined to become follicular cells.<sup>9</sup>

The contribution of mesonephric cells requires migration into the gonad. This movement is regulated by fibroblast growth factor 9 in the male, and it may be repressed by a gene encoding a protein known as SPRY2.<sup>10</sup> Thus, the Y chromosome directs sexual development by influencing gene expression via specific regulating and signaling proteins.

The primordial germ cells originate within the primitive ectoderm, but the specific cells of origin cannot be distinguished.<sup>11</sup> The germ cells are first identified at the end of the 3rd week after fertilization in the primitive endoderm at the caudal end in the dorsal wall of the adjacent yolk sac, and, soon, they also appear in the splanchnic mesoderm of the hindgut.<sup>12,13</sup> The gonadal ridge is the one and only site where the germ cells can survive. By displacement because of growth of the embryo and also by active amoeboid movement along the dorsal mesentery of the hindgut toward the genital ridges, the germ cells “migrate” from the yolk sac around the hindgut to their gonadal sites between weeks 4 and 6 of gestation.<sup>11,14</sup>

The factors that initiate and guide the migration of the germ cells are not known, although chemotactic and adhesive peptides, such as fibronectin and laminin, are

involved. In rodents, germ cell proliferation and migration involve stem cell factor (kit ligand) and the expression of its receptor (c-KIT), a transmembrane tyrosine kinase receptor encoded by the C-KIT oncogene.<sup>15</sup> In gonads obtained from individuals with intersex disorders that have a high risk of testicular tumors, the expression of KIT protein was detected at a later gestational age than in normal controls, consistent with both later germ cell migration and a change in the oncogene expression.<sup>16</sup> The KIT gene is located on chromosome 4, and mutations in this gene have not been discovered in women with premature ovarian failure.<sup>17</sup>

The germ cells begin their proliferation during their migration.<sup>9</sup> The germ cells are the direct precursors of sperm and ova, and by the 6th gestational week, on completion of the indifferent state, these primordial germ cells have multiplied by mitosis to a total of 10,000. By the 6th week of gestation, the indifferent gonads contain the germ cells and supporting cells derived from the coelomic epithelium and the mesenchyme of the gonadal ridge.

Male or female differentiation of the gonad is directed by the sex chromosomes. But the decision to be male or female must be communicated to the cells of the indifferent gonad.<sup>18</sup> This communication, too, is genetic in origin, involving signaling proteins and their receptors, programmed by the fundamental impact that depends on whether a Y chromosome is present. A genetic program involving hundreds of genes is initiated in the indifferent gonad at the urogenital ridge that leads to differentiation into a testis or an ovary.<sup>19</sup>

# The Stage of Differentiation

If the indifferent gonad is destined to become a testis, differentiation along this line will take place at 6–9 gestational weeks. The absence of testicular evolution (formation of medullary primary sex cords, primitive tubules, and incorporation of germ cells) gives implicit evidence of the existence of a primitive, albeit momentarily quiescent, ovary. In contrast to the male, female internal and external genitalia differentiation precedes gonadal maturation. These events are related to the genetic constitution and the territorial receptivity of the mesenchyme. If either factor is deficient or defective, improper development occurs. As has been noted, primitive germ cells are unable to survive in locations other than the gonadal ridge. If partial or imperfect gonadal tissue is formed, the resulting abnormal nonsteroidal and steroidal events have wide ranging morphologic, reproductive, and behavioral effects.

## The Testes

The factor that determines whether the indifferent gonad will become a testis is called, appropriately, the testes-determining factor (TDF), a product of a single gene located on the Y chromosome.<sup>20,21</sup> The testicular-determining factor gene is located within a region named SRY, the sex-determining region on the Y chromosome.<sup>22</sup> The protein product of the SRY gene contains a DNA-binding domain to activate gene transcription that diverts the development of gonadal somatic cells from the pathway of follicle cells to Sertoli cells.<sup>23</sup> Rare cases have been reported of phenotypic, infertile males with a 46, XX karyotype, where the male differentiation is due to a translocation of a Y chromosome fragment containing SRY to an autosome or an X chromosome.

Normal testis development requires not only the presence of the SRY gene but its interaction with autosomal genes.<sup>24,25</sup> Genes similar to SRY have been named SOX genes (the similarity is with the SRY box region that contains the DNA-binding sequence).<sup>23</sup> SRY expression precedes SOX expression; indeed, SRY, acting cooperatively with steroidogenic factor 1, SF1, and FGF9, a member of the fibroblast growth factor family, up-regulates SOX9 gene expression.<sup>21</sup> Thus, SRY along with partner proteins targets male-specific genes that are essential for testicular development. This process is discussed in detail in [Chapter 8](#). In mice, the developmental consequences of activating and inactivating mutations in Sox9 resemble those of similar mutations in SRY, implying not only that Sox9 is required for testis differentiation but also that SRY activation of Sox9 may be all that is necessary to activate other genes important to testis development, such as Fgf9 (fibroblast growth factor 9), and to repress genes that induce ovary development, such as Wnt4 (a member of the wingless family of genes), Rspo1 (R-spondin 1), Dax1 (dosage-sensitive sex

reversal, adrenal hypoplasia critical region, on chromosome X, gene 1), and Foxl2 (forkhead box L2).<sup>26</sup>

Both testis and ovary differentiation require dominantly acting genes, with SRY inducing testis development via up-regulation of SOX9, and with other genes, primarily WNT4 and RSPO1, teaming to promote ovary development via repression of SOX9. This concept views the fate of the bipotential gonad as balanced between opposing forces and SRY as the key factor. In XY gonads, SRY induces SOX9 and tips differentiation toward testis development, and in XX gonads lacking SRY, other genes combine to repress SOX9 and promote ovary development.<sup>27</sup>

The expression of the SRY gene is confined to the genital ridge during fetal life, but the gene is also active in the germ cells of the adult, perhaps playing a role in spermatogenesis.<sup>20</sup> The traditional view assigns **active** gene control and expression for testicular differentiation and a **passive**, “default” mode of development for the ovary. However, recent evidence has challenged that concept, revealing that ovarian development requires the actions of genes such as WNT4, RSPO1, and DAX1, which team to repress the expression of genes in the testis pathway (e.g., SOX9), and other genes that promote ovarian development.<sup>26,28</sup> “Passive” is not an accurate description because even before the gonad differentiates into an ovary, robust gene activity associated with the female genotype occurs in the urogenital ridge.<sup>19</sup>

When the Y chromosome containing SRY is present, the gonads develop into testes. The male phenotype is dependent on the products (antimüllerian hormone and testosterone) of the fetal testes, whereas the female phenotype is the result of an absence of these fetal gonadal products.<sup>29</sup> Anti-müllerian hormone (AMH), which inhibits the formation of the müllerian ducts, is secreted at the time of Sertoli cell differentiation, beginning at 7 weeks. AMH expression is altered only by mutations in the AMH gene, located on chromosome 19p13.3.<sup>30</sup> Regression of the müllerian ducts is dependent on the presence of an adequate number of Sertoli cells, and the regulation of AMH receptor.<sup>31</sup> Mutations in the AMH receptor gene result in the presence of the uterus, fallopian tubes, and the upper vagina in 46,XY men with normal external virilization.

After involution of the müllerian system, AMH continues to be secreted, but there is no known function. However, evidence in the mouse suggests a role in early germ cell transformation during spermatogenesis.<sup>32</sup> In the ovary, very small amounts of AMH mRNA are present early in life, and although there may be no role in female development, its production later in life by the granulosa cells leads to autocrine and paracrine actions in oocyte maturation and follicular development.<sup>33</sup> Serum AMH levels in adult women correlate with the number of ovarian follicles present and predict the response to stimulation with ovulation-inducing therapy.<sup>34</sup>

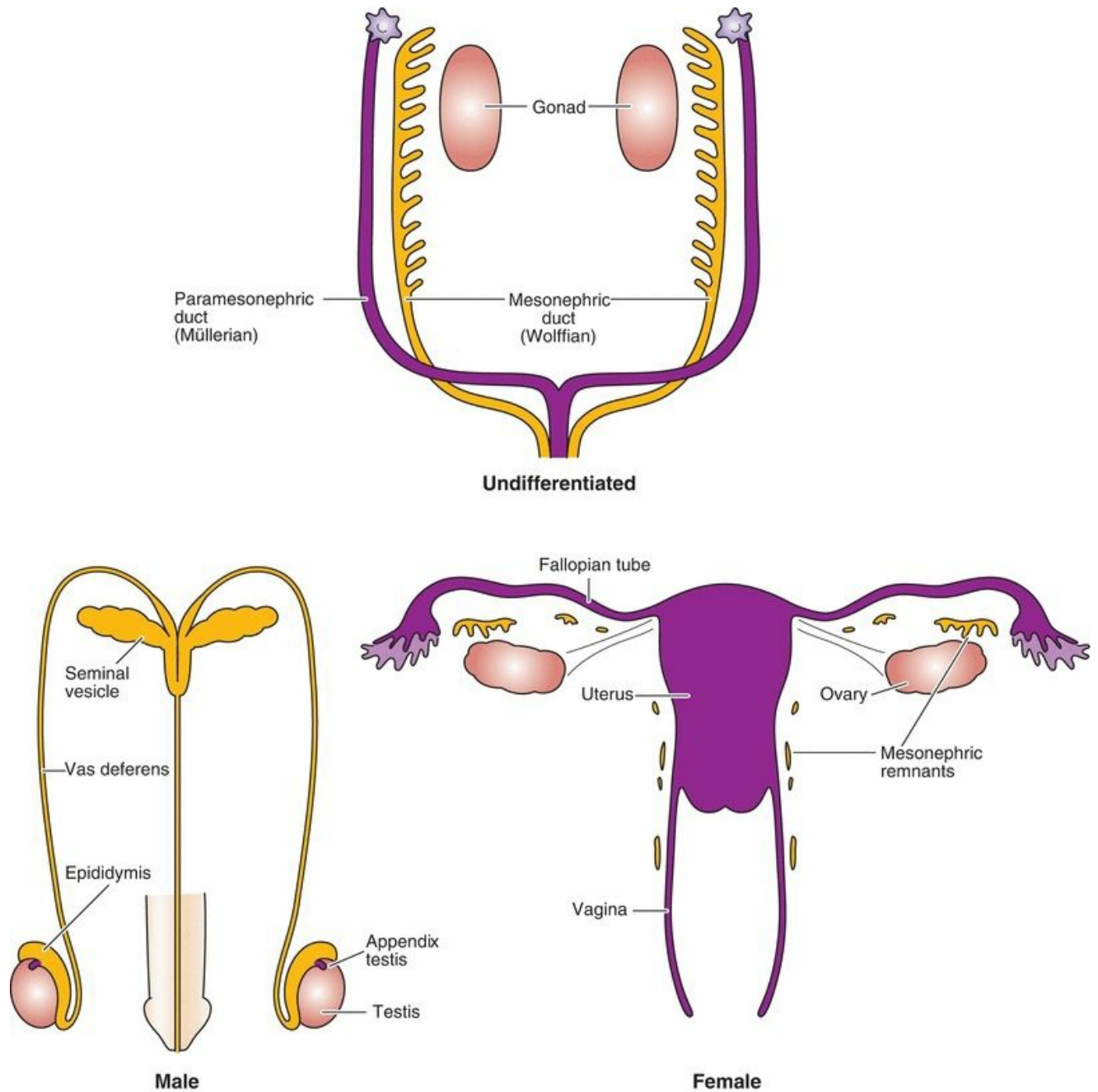
The testis begins its differentiation in week 6–7 of gestation by the appearance of Sertoli cells that aggregate to form the testicular cords. The primordial germ cells are embedded in the testicular cords that will form the Sertoli cells and spermatogonia. The mature Sertoli cells are the site of production of ABP (androgen-binding protein, important in maintaining the high local androgen environment necessary for spermatogenesis) and inhibin.

The Leydig cells differentiate (beginning week 8) from mesenchymal cells of the interstitial component surrounding the testicular cords. Thus, secretion of AMH precedes steroidogenesis in Leydig cells. Shortly after the appearance of the Leydig cells, secretion of testosterone begins. Androgen secretion increases in conjunction with increasing Leydig cell numbers until a peak is reached at 15–18 weeks. At this time, Leydig cell regression begins, and at birth, only a few Leydig cells are present.

The cycle of fetal Leydig cells follows the rise and decline of fetal hCG levels during pregnancy. This relationship and the presence of hCG receptors in the fetal testes indicate a regulatory role for hCG.<sup>4</sup> The pattern of hCG in the fetus parallels that of the mother, peaking at about 10 weeks and declining to a nadir at 20 weeks of gestation, but the concentrations are only 5% of maternal concentrations. hCG stimulation produces Leydig cell hypertrophy, and peak fetal testosterone levels are seen at 15–18 weeks.<sup>35</sup> However, normal masculine differentiation occurs in mouse models lacking LH receptors, and molecular evidence indicates that fetal Leydig cells (but not adult cells) respond to adrenocorticotrophic hormone (ACTH) as well as hCG.<sup>36,37</sup>

Testosterone synthesis in human fetal testes begins at the 8th week of gestation, reaches a peak between 15 and 18 weeks, and then declines. Testicular function in the fetus can be correlated with the fetal hormonal patterns. Although the initial testosterone production and sexual differentiation are in response to the fetal levels of ACTH and hCG, further testosterone production and masculine differentiation are maintained by the fetal pituitary gonadotropins. Decreased testosterone levels in late gestation probably reflect the decrease in gonadotropin levels. The fetal Leydig cells, by an unknown mechanism, avoid down-regulation and respond to high levels of hCG and LH by increased steroidogenesis and cell multiplication. This generation of cells is replaced by the adult generation of Leydig cells that becomes functional at puberty and responds to high levels of hCG and LH with down-regulation and decreased steroidogenesis. Leydig cells, therefore, are composed of two distinct populations, one active during fetal life and one active during adult life.

The fetal spermatogonia, derived from the primordial germ cells, are in the testicular cords, surrounded by the Sertoli cells. In contrast to the female, male germ cells do not start meiotic division before puberty (**Figure 2.1**).



**FIGURE 2.1**

The differentiation of the wolffian system begins with the increase in testicular testosterone production. The classic experiments by Jost indicate that this effect of testosterone is due to local action, explaining why male internal genitalia in true hermaphrodites are only on the side of the testis.<sup>29</sup> Not all androgen-sensitive tissues require the prior conversion of testosterone to dihydrotestosterone (DHT). In the process of masculine differentiation, the development of the wolffian duct structures (epididymis, the vas deferens, and the seminal vesicle) is dependent on testosterone as the intracellular mediator, whereas development of the urogenital sinus and urogenital



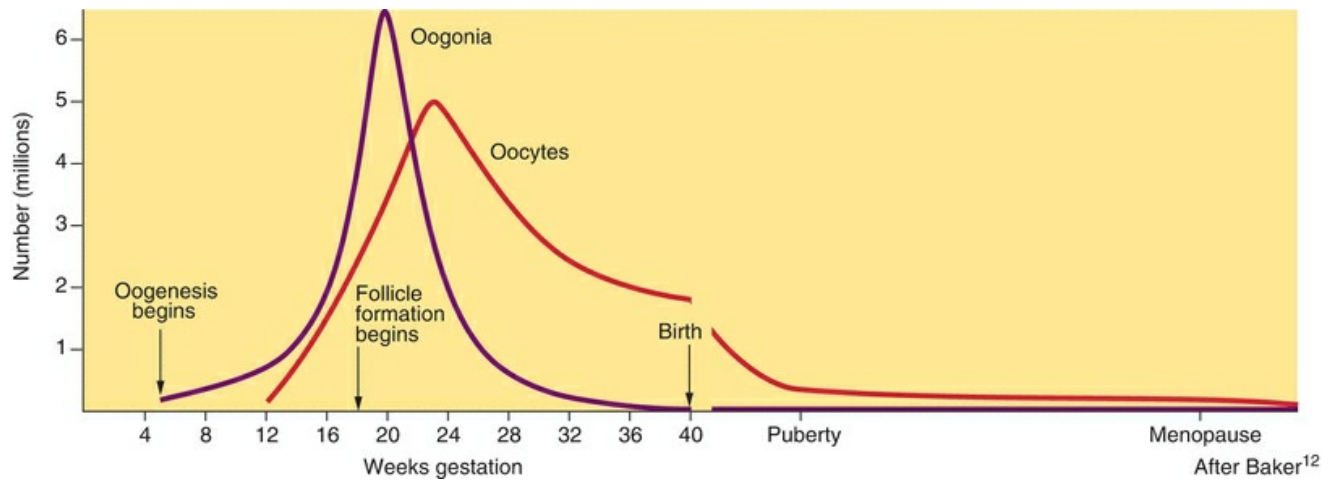
tubercle into the male external genitalia, urethra, and prostate requires the conversion of testosterone to DHT.<sup>38</sup> In the female, the loss of the wolffian system is due to the lack of locally produced testosterone.

# The Stage of Oogonial Multiplication and Oocyte Formation in the Ovary

Just as testicular development requires SRY and SOX9 expression, specific molecular signaling pathways are necessary for ovarian differentiation and oocyte survival. In the developing ovary, the most important genes are WNT4 and RSPO1. Both activate the beta-catenin signaling pathway in somatic cells, which results in the loss of cell-cell adhesion between female germ cells that is required for their entry into meiosis.<sup>39</sup> WNT4 and RSPO1 also cooperate to suppress somatic cell SOX9 expression. Thus, ovarian differentiation is dependent on essential genetic molecular signaling that is active in the absence of SRY. Evidence suggests that RSPO1 also may act directly to suppress male differentiation, even in the absence of SRY.<sup>40</sup> The ultimate fate of the gonad depends on which molecular signaling pathway dominates.<sup>41</sup>

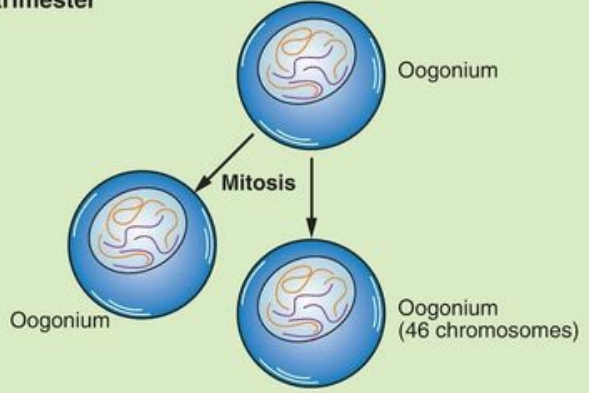
At 6–8 weeks, the first signs of ovarian differentiation are reflected in the rapid mitotic multiplication of germ cells, reaching 6–7 million oogonia by 16–20 weeks.<sup>12,42</sup> This represents the maximal oogonial content of the gonad. From this point in time, germ cell content will irretrievably decrease until, some 50 years later, the store of oocytes will be finally exhausted.

By mitosis, primordial germ cells give rise during week 9 to the oogonia. The oogonia are transformed to oocytes as they enter the first meiotic division and arrest in prophase. This process begins at 11–12 weeks, perhaps in response to a factor or factors produced by the rete ovarii,<sup>43</sup> that may act directly on the germ cells or indirectly via actions on the somatic cells. Studies in mice suggest that retinoic acid derived from the mesonephros may act as a functional meiosis-inducing factor in the female germ cells.<sup>44</sup> Progression of meiosis to the diplotene stage is accomplished throughout the rest of pregnancy and completed by birth. Arrest of meiosis at the diplotene stage of the first meiotic prophase is probably maintained by inhibiting substances produced by granulosa cells. A single ovum is formed from the two meiotic divisions of the oocyte, one just before ovulation and the second (forming the haploid ovum) at the time of sperm penetration. The excess genetic material is extruded as one polar body at each meiotic division. Gonadotropins and various growth factors (but not sex steroids) can induce resumption of meiosis *in vitro*, but only in oocytes enclosed by cumulus-granulosa cells. Follicle-stimulating hormone (FSH) prepares the oocyte for the resumption of meiosis, a process that requires the presence of the gap junction network that allows communication between the cumulus cells and the oocyte. A family of sterols is present in follicular fluid, presumably secreted by the granulosa and cumulus cells in response to gonadotropins, that activates oocyte meiotic resumption and maturation<sup>45,46</sup> (**Figures 2.2 and 2.3**).

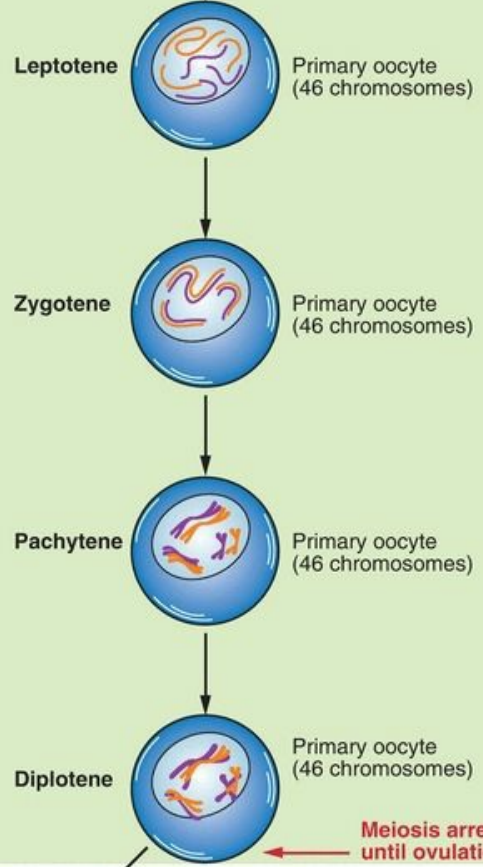


**FIGURE 2.2**

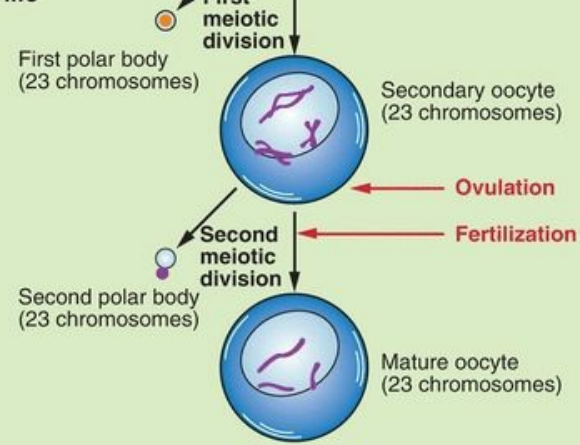
**1st trimester**



**2nd trimester**



**Adult life**



Meiosis I

Meiosis II

## FIGURE 2.3

The massive loss of oocytes during the second half of pregnancy is the consequence of several mechanisms. Besides follicular growth and atresia, substantial numbers of oocytes regress during meiosis, and those oogonia that fail to be enveloped by granulosa cells undergo degeneration. This process is influenced by genes that actively repress germ cell death.<sup>47</sup> In addition, germ cells (in the cortical area) migrate to the surface of the gonad and become incorporated into the surface epithelium or are eliminated into the peritoneal cavity.<sup>48,49</sup> In contrast, once all oocytes are encased in follicles (shortly after birth), the loss of oocytes will be only through the process of follicular growth and atresia.

Chromosomal anomalies can accelerate germ cell loss. Individuals with Turner syndrome (45,X) experience normal migration and mitosis of germ cells, but the oogonia do not undergo meiosis, and rapid loss of oocytes leaves the gonad without follicles early in life, and it appears as a fibrous streak. The rate of loss varies, and 10–20% experience spontaneous menstruation; rare pregnancies have been reported in those who have had spontaneous menstruation.<sup>50,51</sup> However, the presence of menstrual function and reproduction in a patient with Turner phenotype may be due to an undetected mosaic complement, such as a 46,XX line in addition to 45,X.

# The Stage of Follicle Formation

At 18–20 weeks, the highly cellular cortex is gradually perforated by vascular channels originating in the deeper medullary areas, and this marks the beginning of follicle formation.<sup>52</sup> As the finger-like vascular projections enter the cortex, it takes on the appearance of secondary sex cords. As blood vessels invade and penetrate, they divide the previously solid cortical cell mass into smaller and smaller segments. Drawn in with the blood vessels are perivascular cells that originate in the mesonephros or in the coelomic epithelium. Some believe that the coelomic epithelium is the origin of all ovarian somatic cells; others favor a mesenchymal or dual origin.<sup>5,11</sup> These cells give rise to the pregranulosa cells that surround the oocytes, which have completed the first stage of meiosis. The resulting unit is the **primordial follicle—an oocyte arrested in prophase of meiosis, enveloped by a single layer of spindle-shaped pregranulosa cells, surrounded by a basement membrane.** Eventually, all oocytes are covered in this fashion. Residual mesenchyme not utilized in primordial follicle formation is noted in the interstices between follicles, forming the primitive ovarian stroma. This process of primordial follicular development continues until all oocytes in the diplotene stage can be found in follicles, some time shortly after birth.

As soon as the oocyte is surrounded by the rosette of pregranulosa cells, the entire follicle can undergo variable degrees of maturation before arresting and becoming atretic. The formation of a **primary follicle** is marked by a change of the pregranulosa layer to a cuboidal layer of granulosa cells. This change is associated with proliferation. In the human, it is estimated that about 13 pregranulosa cells surround the oocyte, and with the change to a primary follicle, the number increases to about 76 granulosa cells.<sup>53</sup> A later and perhaps more accurate study concluded that the primary follicle contains about 105 granulosa cells, associated with an increase in average diameter from 40 to 54  $\mu\text{m}$ .<sup>54</sup>

Further differentiation into a **preantral follicle** is marked by more complete granulosa proliferation. Call-Exner body formation (which will later coalesce to form an antrum) and occasionally a minor theca layer system that differentiates from surrounding mesenchymal cells can be seen. Preantral follicles can be found in the 6th month of gestation, and **antral follicles** (the graafian follicle, characterized by a fluid-filled space) are present by the end of pregnancy but not in large numbers. It is only during the last 3rd of gestation that theca cells can be found surrounding follicles.<sup>42</sup>

Even in fetal life, the cycle of follicle formation, variable ripening, and atresia occurs. Although these steps are precisely those typical of adult reproductive life, full maturity, as expressed in ovulation, does not occur. Estrogen production does not occur until late in pregnancy when follicular development takes place, and even then,

steroidogenesis is not significant. Unlike the male, gonadal steroid production is not required for development of a normal female phenotype. The development of the müllerian duct into the fallopian tubes, the uterus, and the upper third of the vagina is completely independent of the ovary.

The ovary at birth and in the first year of life can contain cystic follicles of varying size, undoubtedly stimulated by the reactive gonadotropin surge accompanying the withdrawal of the neonatal hypothalamus and pituitary from the negative feedback of fetoplacental steroids.<sup>55</sup> Ovarian cysts can also be occasionally detected in fetuses by ultrasonography.

The anterior pituitary begins development between 4 and 5 weeks of fetal life. The median eminence is apparent by week 9 of gestation, and the hypothalamic-pituitary portal circulation is functional by the 12th week. Pituitary levels of FSH peak at 20–23 weeks and circulating levels peak at 28 weeks.<sup>56</sup> Levels are higher in female fetuses than in males until the last 6 weeks of gestation. Ovaries in anencephalic fetuses, which lack gonadotropin-releasing hormone (GnRH) and gonadotropin secretion, lack antral follicles and existing follicles are smaller at term, but progression through meiosis and development of primordial follicles occurs, obviously not dependent on gonadotropins.<sup>4</sup> The ovary develops receptors for gonadotropins only in the second half of pregnancy. Thus, the loss of oocytes during fetal life cannot be solely explained by the decline in gonadotropins. The follicular growth and development observed in the second half of pregnancy, however, is gonadotropin dependent, and hypophysectomy of a fetal monkey is followed by an increase in oocyte loss by atresia.<sup>57,58</sup>

# THE NEONATAL OVARY

---

The total cortical content of germ cells falls to 500,000–2 million by birth as a result of prenatal oocyte depletion.<sup>59,60,61</sup> This huge depletion of germ cell mass (close to 4–5 million) has occurred over as short a time as 20 weeks. No similar rate of depletion will be seen again. Because of the fixed initial endowment of germ cells, the newborn female enters life, still far from reproductive potential, having lost 80% of her oocytes.

The ovary is approximately 1 cm in diameter and weighs about 250–350 mg at birth, although sizable cystic follicles can enlarge the total dimensions. Intriguingly, the gonad on the right side of the body in both males and females is larger, heavier, and greater in protein and DNA content than the gonad on the left side.<sup>62</sup> Compartmentalization of the gonad into cortex and a small residual medulla has been achieved. In the cortex, almost all the oocytes are enclosed in primordial follicle units. Each ovary contains a similar total number of follicles.<sup>63</sup> Varying degrees of maturation in some units can be seen as in the fetal state.

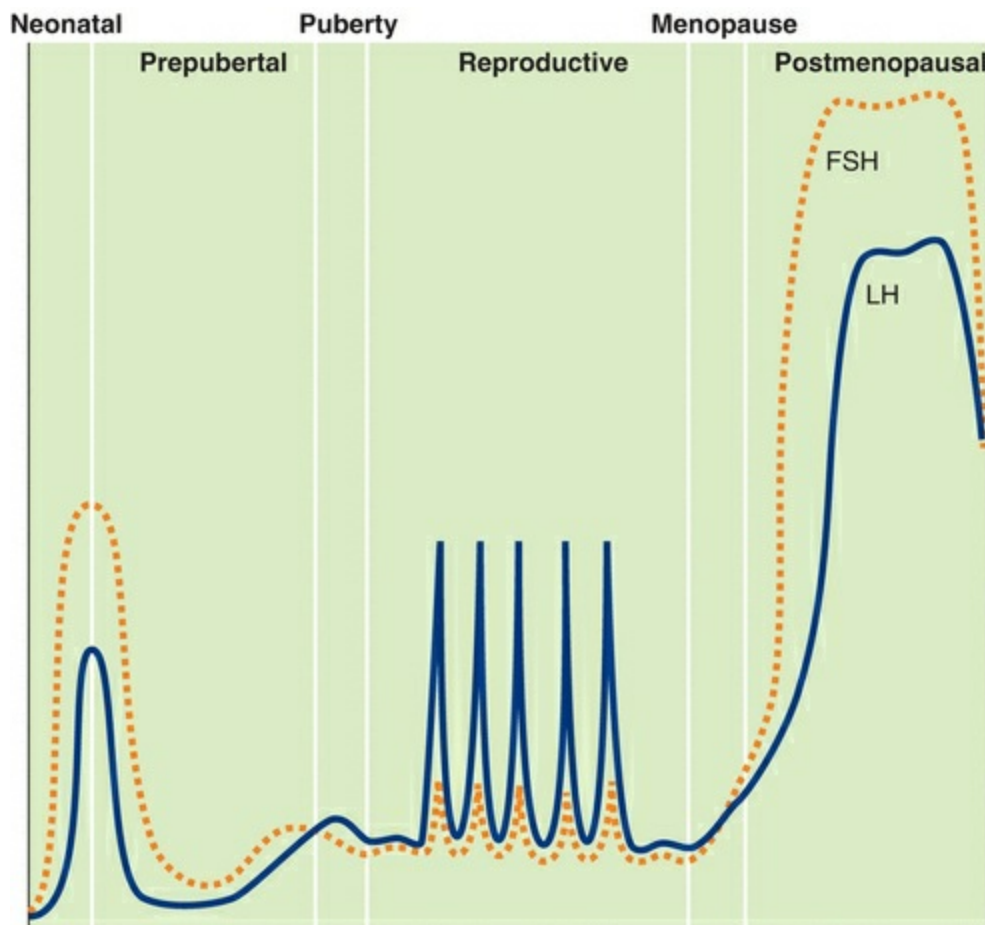
There is a sex difference in fetal gonadotropin levels. There are higher pituitary and circulating FSH and pituitary LH levels in female fetuses. The lower male levels are undoubtedly due to testicular testosterone and inhibin production. In infancy, the postnatal FSH rise is more marked and more sustained in females, whereas LH values are not as high. The FSH levels are greater than the levels reached during a normal adult menstrual cycle, decreasing to low levels usually by 1 year of age but sometimes later.<sup>64</sup> LH levels are in the range of lower adult levels. This early activity is accompanied by inhibin levels comparable to the low range observed during the follicular phase of the menstrual cycle. Follicular growth to the antral stage is relatively common in the first 6 months of life in response to these elevated gonadotropin levels. The most common cause of abdominal masses in fetuses and newborns is ovarian cysts, a consequence of gonadotropin stimulation.<sup>65</sup>

Interference with the postnatal rise in gonadotropins in monkeys is associated with disturbances in normal hypothalamic-pituitary function at puberty.<sup>66</sup> Indeed, in male monkeys, the administration of a GnRH analogue in the neonatal period has an adverse impact on subsequent immunologic and behavioral functions as well as normal reproduction.<sup>66</sup> After the postnatal rise, gonadotropin levels reach a nadir during early childhood (by about 6 months of age in males and 1–2 years in females) and then rise slightly between ages 4 and 10 years.



# THE OVARY IN CHILDHOOD

The childhood period is characterized by low levels of gonadotropins in the pituitary and in the blood, little response of the pituitary to GnRH, and maximal hypothalamic suppression. The ovary, however, is not quiescent during childhood. Follicles begin to grow at all times and frequently reach the antral stage. Ultrasonography can commonly demonstrate ovarian follicular cysts during childhood, ranging in size from 2 to 15 mm.<sup>67</sup> These small unilocular ovarian cysts are not clinically significant.<sup>68</sup> The process of atresia with an increasing contribution of follicular remnants to the stromal compartment yields progressive ovarian enlargement during childhood, about a 10-fold increase in weight.<sup>69</sup> Of course, the lack of gonadotropin support prevents full follicular development and function. There is no evidence that ovarian function is necessary until puberty. However, the oocytes during this time period are active, synthesizing messenger RNAs and protein. Furthermore, ovariectomy in prepubertal monkeys indicates that the prepubertal suppression of GnRH and gonadotropins is partially dependent on the presence of ovaries, suggesting some functional activity of the ovary in childhood<sup>70</sup> (Figure 2.4).



## FIGURE 2.4

# THE ADULT OVARY

---

At the onset of puberty, the germ cell mass has been reduced to 300,000 to 500,000 units.<sup>12,71</sup> During the next 35–40 years of reproductive life, 400–500 will be selected to ovulate, and the primary follicles will eventually be depleted to a point at menopause when only a few hundred to a thousand remain.<sup>72,73,74</sup> A gradually increasing rate of follicular depletion occurs throughout life accounting for a progressively declining number of follicles. In the last 10–15 years before menopause, follicular depletion correlates with a subtle but real increase in FSH and decrease in inhibin-B as well as insulin-like growth factor-1 (IGF-1), and AMH.<sup>34,75,76,77,78,79</sup> Fewer follicles grow per cycle as a woman ages, and cycles are at first shorter because follicular growth begins sooner during the late luteal phase, a consequence of a greater rise in FSH between cycles, and then longer as anovulation becomes more common.<sup>80,81,82,83,84</sup> These changes, including the increase in FSH (which is probably due to the decrease in inhibin-B), may partly reflect the reduced quality and capability of aging follicles. Beginning in their late 30s, women have smaller oocytes and smaller follicles, perhaps of lesser quality.<sup>54</sup> However, the rise in FSH due to a decrease in inhibin-B is also believed to be the consequence of a decreasing number of follicles in each cohort of active follicles.<sup>85</sup>

The acceleration of follicular loss in the later reproductive years has been questioned by a mathematical analysis of normal human ovaries.<sup>86</sup> This model indicates a constantly accelerating loss of follicles from birth to menopause. The rise in FSH and decrease in inhibin-B in the late 30s could still reflect both lesser quality in the remaining follicles and fewer follicles participating in each menstrual cycle.

The classic concept that the mammalian ovary cannot produce new oocytes (and follicles) after fetal life has been challenged. Experimental work that is not without controversy identified stem cells in blood and bone marrow, which after transplantation to a chemically or genetically sterile recipient could generate oocytes within follicles,<sup>87</sup> raising the intriguing possibility of a new approach to treatment for men and women with infertility or reproductive diseases.<sup>88</sup> In addition, putative stem cells have even been isolated from the ovarian surface endothelium, obtained from postmenopausal women and women with premature ovarian failure.<sup>89</sup> This work suggesting neo-oogenesis in adult life is an area of intense debate, including a number of well-designed studies that support the conventional wisdom that each female mammal is born with a finite number of oocytes that were formed in fetal life.<sup>90,91,92</sup>

The loss of oocytes (and follicles) through atresia is a response to changes in many factors. Certainly, gonadotropin stimulation and withdrawal are important, but ovarian

steroids and autocrine and paracrine factors are also involved. The consequence of these unfavorable changes, atresia, is a process called **apoptosis**, programmed cell death. This process is heralded by alterations in mRNAs required for cell proteins that maintain follicle integrity.<sup>93</sup> Indeed, the process is a consequence of an orderly expression of key gene products that either promote or repress the apoptotic events.

Human ovaries and nonhuman primate ovaries are innervated by sympathetic and sensory neurons.<sup>94</sup> This neuronal network innervates the ovarian vasculature, interstitial tissue, and developing follicles. The neurons are connected synaptically to the paraventricular nucleus of the hypothalamus.<sup>95</sup> These neuronal cells produce catecholamines and nerve growth factor. The precise function of this unique ovarian nervous system is not known. Vasoactive intestinal peptide derived from these nerve fibers suppresses follicular atresia (apoptosis) in a mechanism that also involves IGF-1.<sup>96</sup> It has been suggested that sympathetic innervation of the ovary continues to develop at puberty and that neurotransmitters are involved in the process in which follicles acquire FSH receptors and respond to FSH.<sup>97,98</sup>

During the reproductive years, the typical cycle of follicle maturation, including ovulation and corpus luteum formation, is realized. This results from the complex but well-defined sequence of hypothalamic-pituitary-gonadal interactions in which follicle and corpus luteum steroid hormones, pituitary gonadotropins, and autocrine and paracrine factors are integrated to yield ovulation. These important events are described in detail in [Chapters 4](#) and [5](#). For the moment, our attention is exclusively directed to a description of the events as the gonad is driven inexorably to final and complete exhaustion of its germ cell supply. The major feature of this reproductive period in the ovary's existence is the full maturational expression of some follicle units in ovulation and corpus luteum formation and the accompaniment of varying steroid output of estradiol and progesterone. For every follicle that ovulates, close to 1,000 will pursue abortive growth periods of variable length.

# Follicular Growth

In the adult ovary, the stages of follicle development observed in the prenatal period are repeated but to a more complete degree. Progression from primordial to primary follicle occurs, and the zona pellucida begins to form, followed by further enlargement of the oocyte enlarges and marked proliferation of the granulosa cells. A solid sphere of cells encasing the oocyte is formed. At this point, the theca interna is noted in initial stages of formation.

The time that elapses in progressing from a primary follicle to ovulation is approximately 85 days.<sup>99,100</sup> The majority of this time passes in development that is independent of gonadotropins, achieving a state of readiness that will yield further growth in response to FSH stimulation. If gonadotropin increments are available, as can be seen early in a menstrual cycle, a further FSH-dependent stage of follicle maturation is seen. The number of follicles that mature is dependent on the amount of FSH available to the gonad and the sensitivity of the follicles to the gonadotropins. FSH receptor expression is greatest in granulosa cells, but significant expression can be detected in ovarian surface epithelium and fallopian tube epithelium, where the function is uncertain, but a role in epithelium-derived tumors is possible.<sup>101</sup>

The antrum first appears as a coalescence of numerous cavities between granulosa cells called Call-Exner bodies, which were described by Emma Call and Siegmund Exner in Vienna, in 1875. Emma Call was one of the first woman physicians in the United States.<sup>102</sup> After receiving her medical degree from the University of Michigan in 1873, she went to Vienna as Exner's postgraduate student. She returned to Boston and practiced as an obstetrician for more than 40 years. Emma Call was the first woman elected to the Massachusetts Medical Society (in 1884). Her description of the Call-Exner bodies was her only publication.

Whether Call-Exner bodies represent liquefaction or granulosa cell secretion is uncertain. At first, the cavity is filled with a coagulum of cellular debris. Soon a liquor accumulates, which is essentially a transudation of blood filtered through the avascular granulosa from the theca vessels. With antral formation, the theca interna develops more fully, expressed by increased cell mass, increased vascularity, and the formation of lipid-rich cytoplasmic vacuoles within the theca cells. As the follicle expands, the surrounding stroma is compressed and is called the theca externa.

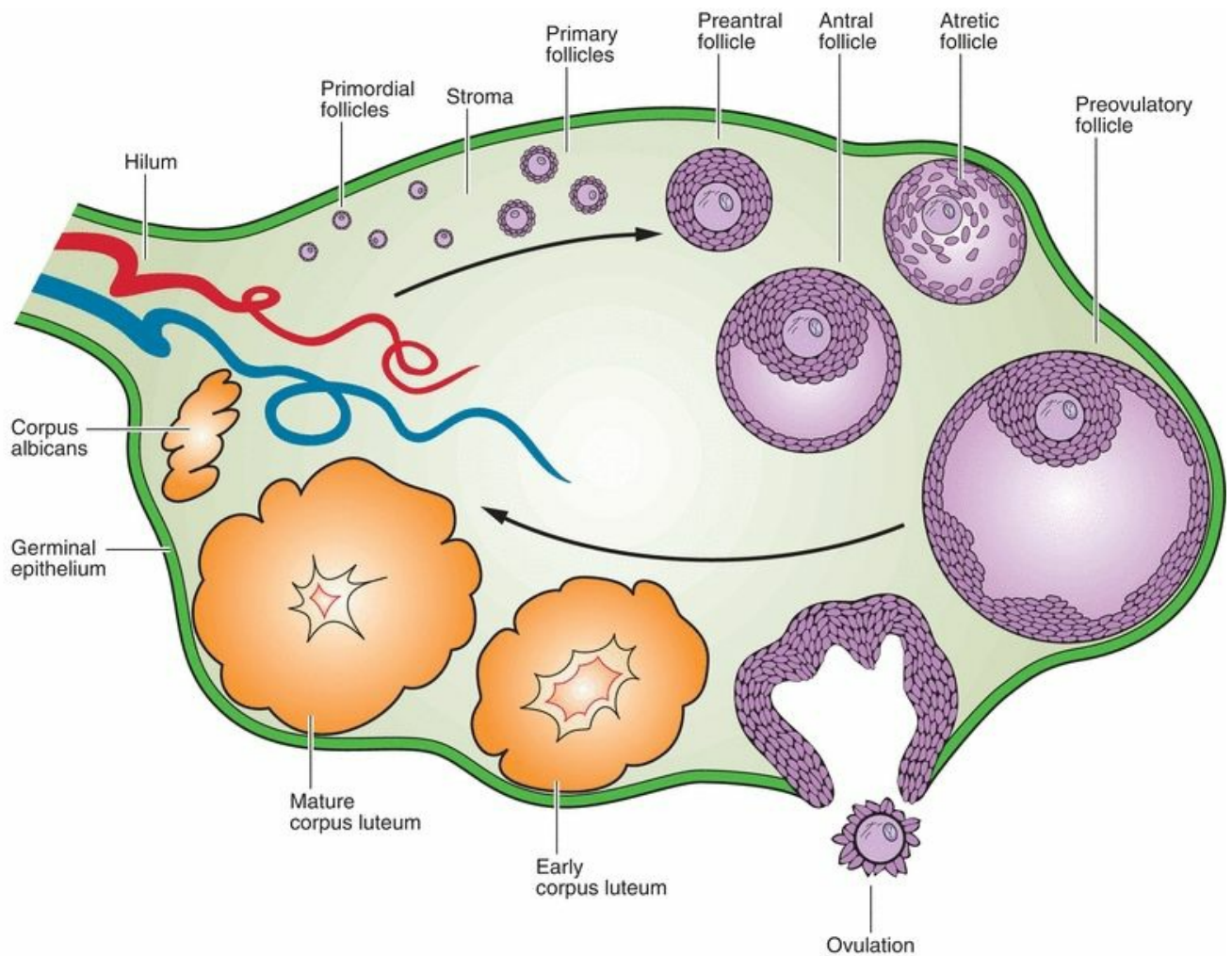
The granulosa cells that surround the oocyte are avascular and separated from the surrounding stroma by a basement membrane. Deprived of a vascular supply until after ovulation, the granulosa cells depend on specialized gap junctions that connect cells and communicate with the oocyte for the purpose of metabolic exchange and the transport of signaling molecules. It is this structure that allows repression and stimulation for the

correct timing of meiosis. The granulosa cells differ in function and activity; for example, LH receptor concentrations are highest in those cells closest to the basement membrane and lowest in those that surround the oocyte.<sup>103</sup>

At any point during follicle development, individual follicles may become arrested and eventually regress through an apoptotic process known as atresia. At first, the granulosa component begins to disrupt. The antral cavity constituents are resorbed, and the cavity collapses and obliterates. The oocyte degenerates in situ. Finally, a ribbon-like scarred streak surrounded by theca is seen. Eventually, this theca mass loses its lipid and becomes indistinguishable from the growing mass of stroma. Thus, the process of apoptosis is extensive in the granulosa, and the theca layer is largely spared to be incorporated into the interstitial tissue. Prior to regression, cystic follicles can be retained in the cortex for variable periods of time.

# Ovulation

If gonadotropin stimulation is adequate, one of the several follicle units propelled to varying degrees of maturity will advance to ovulation. Morphologically, these events include distention of the antrum by increments of antral fluid and compression of the granulosa against the limiting membrane separating the avascular granulosa and the luteinized, vascularized theca interna. In addition, the antral fluid increment gradually pinches off the cumulus oophorus, the mound of granulosa enveloping the oocyte. The mechanisms of the thinning of the theca over the surface of the now protruding, distended follicle, the creation of an avascular area weakening the ovarian capsule, and the final acute distention of the antrum with rupture and extrusion of the oocyte in its cumulus are multiple and complex (discussed in [Chapter 6](#)). Repeated evaluation of intrafollicular pressures has failed to indict an explosive factor in this crucial event ([Figure 2.5](#)).



**FIGURE 2.5**

As demonstrated in a variety of animal experiments, the physical expulsion of the oocyte is dependent on a preovulatory surge in prostaglandin synthesis within the follicle. Inhibition of this prostaglandin synthesis produces a corpus luteum with an entrapped oocyte. Both prostaglandins and the midcycle surge of gonadotropins are thought to increase the concentration and activity of local proteases, such as plasminogen conversion to plasmin. As a result of generalized tissue weakening (loss of intercellular gap junction integrity and disruption of elastic fibers), there is swift accumulation of antral fluid followed by rupture of the weakened tissue envelope surrounding the follicle.



# Corpus Luteum

Shortly after ovulation, profound alterations in cellular organization occur in the ruptured follicle that go well beyond simple repair. After tissue integrity and continuity are retrieved, the granulosa cells hypertrophy markedly, gradually filling in the cystic, sometimes hemorrhagic, cavity of the early corpus luteum. In addition, for the first time, the granulosa becomes markedly luteinized by incorporation of lipid-rich vacuoles within its cytoplasm. Both these properties had been the exclusive features of the theca prior to ovulation. For its part, the theca of the corpus luteum becomes less prominent, vestiges being noted eventually only in the interstices of the typical scalloping of the mature corpus luteum. As a result, a new yellow body is formed, now dominated by the enlarged, lipid-rich, fully vascularized granulosa. In the 14 days of its life, dependent on the low but important quantities of LH available in the luteal phase, this unit produces estradiol and progesterone. Unless rescued by rising levels of hCG from a successful implantation, the corpus luteum rapidly ages. Its vascularity and lipid content wane, and the sequence of scarification (albicantia) ensues.

# Modulators of Function

The complex events that yield an ovum for fertilization and ovarian structures that provide hormonal secretion are the products of essentially every regulating mechanism in human biology. This includes classic endocrine signals, autocrine and paracrine/intracrine regulation, neuronal input, and immune system contributions. Representatives of the white blood cell series constitute a major component of the ovarian stromal (interstitial) compartment. Macrophages present in permanent, noncyclic numbers may influence ovarian function through the secretion of regulatory cytokines.<sup>104</sup> During the adult ovarian cycle, there is an infiltration of white blood cells in a pattern characterized by increasing numbers of mast cells culminating in degranulation and release of histamine that is associated with hyperemia at ovulation.<sup>105</sup> The corpus luteum attracts eosinophils and T lymphocytes, which signal and activate monocytes and macrophages involved in luteolysis. However, this immune mechanism should be viewed not just as a healing and resolving response but also as an important regulatory system (involving the secretion of cytokines and growth factors) for ovarian function.<sup>104</sup>

# REFERENCES

1. **Graham H**, *Eternal Eve, The History of Gynaecology & Obstetrics*, Doubleday & Company, Inc., Garden City, 1951.
2. **Magner LN**, *A History of Medicine*, Marcel Dekker, Inc., New York, 1992.
3. **Short RV**, The discovery of the ovaries, In: Zuckerman S, Weir BJ, eds. *The Ovary*, 2nd ed, Vol. 1, Academic Press, New York, 1977, p. 1.
4. **Rabinovici J, Jaffe RB**, Development and regulation of growth and differentiated function of human and subhuman primate fetal gonads, *Endocr Rev* 11:532, 1990.
5. **Motta PM, Nottola SA, Familiari G, Makabe S, Stallone T, Macchiarelli G**, Morphodynamics of the follicular-luteal complex during early ovarian development and reproductive life, *Int Rev Cytol* 223:177, 2003.
6. **Yoshinaga K, Hess DL, Hendrickx AG, Zamboni L**, The development of the sexually indifferent gonad in the prosimian, *Galago crassicaudatus crassicaudatus*, *Am J Anat* 181:89, 1988.
7. **Nishino K, Yamanouchi K, Naito K, Tojo H**, Characterization of mesonephric cells that migrate into the XY gonad during testis differentiation, *Exp Cell Res* 267:225, 2001.
8. **Wrobel KH, Hees I, Schimmel M, Stauber E**, The genus *Acipenser* as a model system for vertebrate urogenital development: nephrostomial tubules and their significance for the origin of the gonad, *Anat Embryol* 205:67, 2002.
9. **Motta PM, Makabe S, Nottola SA**, The ultrastructure of human reproduction. I. The natural history of the female germ cell: origin, migration and differentiation inside the developing ovary, *Hum Reprod Update* 3:281, 1997.
10. **Chi L, Itäranta P, Zhang S, Vainio S**, Sprouty2 is involved in male sex organogenesis by controlling fibroblast growth factor-induced mesonephric cell migration to the developing testis, *Endocrinology* 147:3777, 2006.
11. **Pereda M, Zorn T, Soto-Suazo M**, Migration of human and mouse primordial germ cells and colonization of the developing ovary: an ultrastructural and cytochemical study, *Microsc Res Tech* 69:386, 2006.
12. **Baker TG**, A quantitative and cytological study of germ cells in human ovaries, *Proc R Soc Lond B Biol Sci* 158:417, 1963.
13. **Wylie C**, Germ cells, *Cell* 96:165, 1999.
14. **Motta PM, Nottola SA, Makabe S**, Natural history of the female germ cell from its origin to full maturation through prenatal ovarian development, *Eur J Obstet Gynecol Reprod Biol* 75:5, 1997.
15. **Runyan C, Schaible K, Molyneaux K, Wang Z, Levin L, Wylie C**, Steel factor controls midline cell death of primordial germ cells and is essential for their normal proliferation and migration, *Development* 133:4861, 2006.
16. **Meyts ER, Jorgensen N, Muller J, Skakkebaek NE**, Prolonged expression of the c-kit receptor in germ cells of intersex fetal testes, *J Pathol* 178:166, 1996.
17. **Shibanuma K, Tong Z-B, Vanderhoof VH, Vanevski K, Nelson LM**, Investigation of KIT gene mutations in women with 46,XX spontaneous premature ovarian failure, *BMC Womens Health* 2:8, 2002.
18. **Best D, Sahlender DA, Walther N, Peden AA, Adams IR**, Sdmgl is a conserved transmembrane protein associated with germ cell sex determination and germline-soma interactions in mice, *Development* 135:1415, 2008.
19. **Nef S, Schaad O, Stallings NR, Cederroth CR, Pitetti JL, Schaer G, Malki S, Dubois-Dauphin M, Boizet-Bonhoure B, Descombes P, Parker KL, Vassalli JD**, Gene expression during sex determination reveals a robust female genetic program at the onset of ovarian development, *Dev Biol* 287:361, 2005.
20. **Sinclair AH, Berta P, Palmer MS, Hawkins JR, Griffiths BL, Smith JJ, Foster JW, Frischauf A-M, Lovell-Badge R, Goodfellow PN**, A gene from the human sex-determining region encodes a protein with homology to a conserved DNA-binding motif, *Nature* 346:240, 1990.
21. **Sekido R, Lovell-Badge R**, Sex determination involves synergistic action of SRY and SF1 on a specific Sox9 enhancer, *Nature* 453:930, 2008.
22. **Tho SPT, Layman LC, Lanclos DK, Plouffe L Jr, Byrd JR, McDonough PG**, Absence of the testicular

- determining factor gene SRY in XX true hermaphrodites and presence of this locus in most subjects with gonadal dysgenesis caused by Y aneuploidy, *Am J Obstet Gynecol* 167:1794, 1992.
23. **Whitfield LS, Lovell-Badge R, Goodfellow PN**, Rapid sequence evolution of the mammalian sex-determining gene SRY, *Nature* 364:713, 1993.
  24. **Foster JW, Dominguez-Steglich MA, Guioli S, Kowk G, Weller PA, Stevanovic M, Weissenbach J, Mansour S, Young ID, Goodfellow PN, Brook JD, Schafer AJ**, Campomelic dysplasia and autosomal sex reversal caused by mutations in an SRY-related gene, *Nature* 372:525, 1994.
  25. **Chaboissier MC, Kobayashi A, Vidal VI, Lützkendorf S, van de Kant JH, Wegner M, de Rooij DG, Behringer RR, Schedl A**, Functional analysis of Sox8 and Sox9 during sex determination in the mouse, *Development* 131:1891, 2004.
  26. **Sekido R, Lovell-Badge R**, Sex determination and SRY: down to a wink and a nudge? *Trends Genet* 25:19, 2009.
  27. **Cool J, Capel B**, Mixed signals: development of the testis, *Semin Reprod Med* 27:5, 2009.
  28. **Smith M**, The year in human and medical genetics. Highlights of 2007–2008, *Ann N Y Acad Sci* 1151:1, 2009.
  29. **Jost A, Vigier B, Prepin J, Perchellet JP**, Studies on sex differentiation in mammals, *Recent Prog Horm Res* 29:1, 1973.
  30. **Rey R, Al-Attar L, Louis F, Jaubert F, Barbet P, Nihoul-Fekete C, Chaussain JL, Josso N**, Testicular dysgenesis does not affect expression of anti-müllerian hormone by Sertoli cells in premeiotic seminiferous tubules, *Am J Pathol* 148:1689, 1996.
  31. **Teixeira J, He WW, Shah PC, Morikawa N, Lee MM, Catlin EA, Hudson PL, Wing J, Maclaughlin DT, Donahoe PK**, Developmental expression of a candidate müllerian inhibiting substance type II receptor, *Endocrinology* 137:160, 1996.
  32. **Zhou B, Hutson JM**, Human chorionic gonadotropin (hCG) fails to stimulate gonocyte differentiation in newborn mouse testes in organ culture, *J Urol* 153:501, 1995.
  33. **Kim JH, Seibel MM, MacLaughlin DT, Donahoe PK, Ransil BJ, Hametz PA, Richards CJ**, The inhibitory effects of müllerian-inhibiting substance on epidermal growth factor induced proliferation and progesterone production of human granulosa-luteal cells, *J Clin Endocrinol Metab* 75:911, 1992.
  34. **Lie Fong S, Baart EB, Martini E, Schipper I, Visser JA, Themmen APN, de Jong FH, Fauser BJCM, Laven JSE**, Anti-müllerian hormone: a marker for oocyte quantity, oocyte quality and embryo quality? *Reprod Biomed Online* 16:664, 2008.
  35. **Wilson JD, Griffin JE, George FW, Leshin M**, The role of gonadal steroids in sexual differentiation, *Recent Prog Horm Res* 37:1, 1981.
  36. **O'Shaughnessy PJ, Fleming LM, Jackson G, Hochgeschwender U, Reed P, Baker PJ**, Adrenocorticotrophic hormone directly stimulates testosterone production by the fetal and neonatal mouse testis, *Endocrinology* 144:3279, 2003.
  37. **Kremer H, Kraaij R, Toledo SPA, Post M, Fridman JB, Hayashida CY, van Reen M, Milgrom E, Ropers H, Mariman E, Themmen APN, Brunner HG**, Male pseudohermaphroditism due to a homozygous missense mutation of the luteinizing hormone receptor gene, *Nat Genet* 9:160, 1995.
  38. **Mooradian AD, Morley JE, Korenman SG**, Biological actions of androgens, *Endocr Rev* 8:1, 1987.
  39. **Chassot AA, Ranc F, Gregoire EP, Roepers-Gajadien HL, Takeito MM, Camerino G, De Rooij DG, Schedl A, Chaboissier MC**, Activation of beta-catenin signaling by Rspo1 controls differentiation of the mammalian ovary, *Hum Mol Genet* 17:1264, 2008.
  40. **Tomizuka K, Horikoshi K, Kitada R, Sugawara Y, Iba Y, Kojima A, Yoshitome A, Yamawaki K, Amagai M, Inoue A, Oshima T, Kakitani M**, R-spondin1 plays an essential role in ovarian development through positively regulating Wnt-4 signaling, *Hum Mol Genet* 17:1278, 2008.
  41. **Kim Y, Kobayashi A, Sekido R, DiNapoli L, Brennan J, Chaboissier MC, Poulat F, Behringer RR, Lovell-Badge R, Capel B**, Fgf9 and Wnt4 act as antagonistic signals to regulate mammalian sex determination, *PLoS Biol* 4: e187, 2006.
  42. **Gondos B, Bhiraleus P, Hobel C**, Ultrastructural observations on germ cells in human fetal ovaries, *Am J Obstet Gynecol* 110:644, 1971.

43. **Gondos B, Westergaard L, Byskov A**, Initiation of oogenesis in the human fetal ovary: ultrastructural and squash preparation study, *Am J Obstet Gynecol* 155:189, 1986.
44. **Wilhelm D, Palmer S, Koopman P**, Sex determination and gonadal development in mammals, *Physiol Rev* 87:1, 2007.
45. **Byskov AG, Andersen CY, Nordholm L, Thogersen H, Xia G, Wassmann O, Andersen JV, Guddal E, Roed T**, Chemical structure of sterols that activate oocyte meiosis, *Nature* 374:559, 1995.
46. **Byskov AG, Andersen CY, Leonardsen L**, Role of meiosis activating sterols, MAS, in induced oocyte maturation, *Mol Cell Endocrinol* 187:189, 2002.
47. **Ratts VS, Flaws JA, Kolp R, Sorenson CM, Tilly JL**, Ablation of bcl-2 gene expression decreases the numbers of oocytes and primordial follicles established in the post-natal female mouse gonad, *Endocrinology* 136:3665, 1995.
48. **Motta PM, Makabe S**, Germ cells in the ovarian surface during fetal development in humans. A three-dimensional microanatomical study by scanning and transmission electron microscopy, *J Submicrosc Cytol* 18:271, 1986.
49. **Speed RM**, The possible role of meiotic pairing anomalies in the atresia of human fetal oocytes, *Hum Genet* 78:260, 1988.
50. **Pasquino AM, Passeri F, Pucarelli I, Segni M, Municchi G**, Spontaneous pubertal development in Turner's syndrome. Italian Study Group for Turner's Syndrome, *J Clin Endocrinol Metab* 82:1810, 1997.
51. **Kaneko N, Kawagoe S, Hiroi M**, Turner's syndrome—Review of the literature with reference to a successful pregnancy outcome, *Gynecol Obstet Invest* 29:81, 1990.
52. **Ammini AC, Pandey J, Vijayaraghavan M, Sabherwal U**, Human female phenotypic development: role of fetal ovaries, *J Clin Endocrinol Metab* 79:604, 1994.
53. **Gougeon A, Chainy GBN**, Morphometric studies of small follicles in ovaries of women at different ages, *J Reprod Fertil* 81:433, 1987.
54. **Westergaard CG, Byskov AG, Andersen CY**, Morphometric characteristics of the primordial to primary follicle transition in the human ovary in relation to age, *Hum Reprod* 22:2225, 2007.
55. **Cohen HL, Shapiro MA, Mandel FS, Shapiro ML**, Normal ovaries in neonates and infants: a sonographic study of 77 patients 1 day to 24 months old, *Am J Roentgenol* 160:583, 1993.
56. **DiVall SA, Radovick S**, Pubertal development and menarche, *Ann N Y Acad Sci* 1135:19, 2008.
57. **Thomas GB, McNeilly AS, Gibson F, Brooks AN**, Effects of pituitary-gonadal suppression with a gonadotrophin-releasing hormone agonist on fetal gonadotrophin secretion, fetal gonadal development and maternal steroid secretion in the sheep, *J Endocrinol* 141:317, 1994.
58. **Gulyas BJ, Hodgen GD, Tullner WW, Ross GT**, Effects of fetal or maternal hypophysectomy on endocrine organs and body weight in infant rhesus monkeys (*Macaca mulatta*) with particular emphasis on oogenesis, *Biol Reprod* 16:216, 1977.
59. **Himmelstein-Braw R, Byskov AG, Peters H, Faber M**, Follicular atresia in the infant human ovary, *J Reprod Fertil* 46:55, 1976.
60. **Forabosco A, Sforza C, De Pol A, Vizzotto L, Marzona L, Ferrario VG**, Morphometric study of the human neonatal ovary, *Anat Rec* 231:201, 1991.
61. **Forabosco A, Sforza C**, Establishment of ovarian reserve: a quantitative morphometric study of the developing human ovary, *Fertil Steril* 88:675, 2007.
62. **Mittwoch U, Mahadevaiah S**, Comparison of development of human fetal gonads and kidneys, *J Reprod Fertil* 58:463, 1980.
63. **Charleston JS, Hansen KR, Thyer AC, Charleston LB, Gougeon A, Siebert JR, Soules MR, Klein NA**, Estimating human ovarian non-growing follicle number: the application of modern sterology techniques to an old problem, *Hum Reprod* 22:2103, 2007.
64. **Burger HG, Famada Y, Bangah ML, McCloud PI, Warne GL**, Serum gonadotropin, sex steroid, and immunoreactive inhibin levels in the first two years of life, *J Clin Endocrinol Metab* 72:682, 1991.
65. **Hengster P, Menardi G**, Ovarian cysts in the newborn, *Pediatr Surg Int* 7:372, 1992.
66. **Mann DR, Akinbami MA, Gould KG, Tanner JM, Wallen K**, Neonatal treatment of male monkeys with a

gonadotropin-releasing hormone agonist alters differentiation of central nervous system centers that regulate sexual and skeletal development, *J Clin Endocrinol Metab* 76:1319, 1993.

67. **Cohen HL, Eisenberg P, Mandel F, Haller JO**, Ovarian cysts are common in premenarchal girls: a sonographic study of 101 children 2–12 years old, *AJR Am J Roentgenol* 159:89, 1992.
68. **Millar DM, Blake JM, Stringer DA, Hara H, Babiak C**, Prepubertal ovarian cyst formation: 5 years' experience, *Obstet Gynecol* 81:434, 1993.
69. **Bridges NA, Cooke A, Healy MJ, Hindmarsh PC, Brook CG**, Standards for ovarian volume in childhood and puberty, *Fertil Steril* 60:456, 1993.
70. **Pohl CR, de Ridder CM, Plant TM**, Gonadal and nongonadal mechanisms contribute to the prepubertal hiatus in gonadotropin secretion in the female rhesus monkey (*Macaca mulatta*), *J Clin Endocrinol Metab* 80:2094, 1995.
71. **Block E**, Quantitative morphological investigations of the follicular system in women, *Acta Anat* 14:108, 1952.
72. **Richardson SJ, Senikas V, Nelson JF**, Follicular depletion during the menopausal transition—evidence for accelerated loss and ultimate exhaustion, *J Clin Endocrinol Metab* 65:1231, 1987.
73. **Faddy MJ, Gosden RG, Gougeon A, Richardson SJ, Nelson JF**, Accelerated disappearance of ovarian follicles in mid-life: implications for forecasting menopause, *Hum Reprod* 7:1342, 1992.
74. **Gougeon A, Echiohard R, Thalabard JC**, Age-related changes of the population of human ovarian follicles: increase in the disappearance rate of non-growing and early-growing follicles in aging women, *Biol Reprod* 50:653, 1994.
75. **Metcalf MG, Livesay JH**, Gonadotropin excretion in fertile women: effect of age and the onset of the menopausal transition, *J Endocrinol* 105:357, 1985.
76. **Lee SJ, Lenton EA, Sexton L, Cooke ID**, The effect of age on the cyclical patterns of plasma LH, FSH, oestradiol and progesterone in women with regular menstrual cycles, *Hum Reprod* 3:851, 1988.
77. **Hughes EG, Robertson DM, Handelsman DJ, Hayward S, Healy DL, de Kretser DM**, Inhibin and estradiol responses to ovarian hyperstimulation: effects of age and predictive value for in vitro fertilization outcome, *J Clin Endocrinol Metab* 70:358, 1990.
78. **Klein NA, Battaglia DE, Fujimoto VY, Davis GS, Bremmer WJ, Soules MR**, Reproductive aging: accelerated ovarian follicular development associated with a monotropic follicle-stimulating hormone rise in normal older women, *J Clin Endocrinol Metab* 81:1038, 1996.
79. **Klein NA, Illingworth PJ, Groome NP, McNeilly AS, Battaglia DE, Soules MR**, Decreased inhibin B secretion is associated with the monotropic FSH rise in older, ovulatory women: a study of serum and follicular fluid levels of dimeric inhibin A and B in spontaneous menstrual cycles, *J Clin Endocrinol Metab* 81:2742, 1996.
80. **Treloar AE, Boynton RE, Borghild GB, Brown BW**, Variation of the human menstrual cycle through reproductive life, *Int J Fertil* 12:77, 1967.
81. **Lenton EA, Landgren B, Sexton L, Harper R**, Normal variation in the length of the follicular phase of the menstrual cycle: effect of chronological age, *Br J Obstet Gynaecol* 91:681, 1984.
82. **Cha KY, Koo JJ, Ko JJ, Choi DH, Han SY, Yoon TK**, Pregnancy after IVF of human follicular oocytes collected from nonstimulated cycles, their culture in vitro and their transfer in a donor oocyte program, *Fertil Steril* 55:109, 1991.
83. **Klein NA, Harper AJ, Houmard BS, Sluss PM, Soules MR**, Is the short follicular phase in older women secondary to advanced or accelerated dominant follicle development? *J Clin Endocrinol Metab* 87:5746, 2002.
84. **van Zonneveld P, Scheffer GJ, Broekmans FJ, Blankenstein MA, de Jong FH, Looman CW, Habbema JD, te Velde ER**, Do cycle disturbances explain the age-related decline of female fertility? Cycle characteristics of women aged over 40 years compared with a reference population of young women, *Hum Reprod* 18:495, 2003.
85. **Klein NA, Battaglia DE, Miller PB, Branigan EF, Giudice LC, Soules MR**, Ovarian follicular development and the follicular fluid hormones and growth factors in normal women of advanced reproductive age, *J Clin Endocrinol Metab* 81:1946, 1996.
86. **Hansen KR, Knowlton NS, Thyer AC, Charleston JS, Soules MR, Klein NA**, A new model of reproductive aging: the decline in ovarian non-growing follicle number from birth to menopause, *Hum Reprod*

23:699, 2008.

87. **Tilly JL, Johnson J**, Recent arguments against germ cell renewal in the adult human ovary, *Cell Cycle* 6:879, 2007.
88. **Tilly JL, Rueda BR**, Minireview: stem cell contribution to ovarian development, function, and disease, *Endocrinology* 149:4307, 2008.
89. **Virant-Klun I, Zech N, Rozman P, Vogler A, Cvjeticanin B, Klemenc P, Malicev E, Meden-Vrtovec H**, Putative stem cells with an embryonic character isolated from the ovarian surface epithelium of women with no naturally present follicles and oocytes, *Differentiation* 76:843, 2008.
90. **Begum S, Papaioannou VE, Gosden RG**, The oocyte population is not renewed in transplanted or irradiated adult ovaries, *Hum Reprod* 23:2326, 2008.
91. **Zhang H, Zheng W, Shen Y, Adhikari D, Ueno H, Liu K**, Experimental evidence showing that no mitotically active female germline progenitors exist in postnatal mouse ovaries. *Proc Natl Acad Sci U S A* 109:12580, 2012.
92. **Lei L, Spradling AC**, Female mice lack adult germ-line stem cells but sustain oogenesis using stable primordial follicles. *Proc Natl Acad Sci U S A* 110:8585, 2013.
93. **Tilly JL, Kowalski KI, Schomberg DW, Hsueh AJ**, Apoptosis in atretic ovarian follicles is associated with selected decreases in messenger ribonucleic acid transcripts for gonadotropin receptors and cytochrome P450 aromatase, *Endocrinology* 131:1670, 1992.
94. **Dees WL, Hiney JK, Schulte TD, Mayerhofer A, Danilchik M, Dissen GA, Ojeda SR**, The primate ovary contains a population of catecholaminergic neuron-like cells expressing nerve growth factor receptors, *Endocrinology* 136:5760, 1995.
95. **Luza SM, Arancibia S, Venegas M, Lara HE**, Thyrotropin-releasing hormone as a mediator of the central autonomic pathway controlling ovarian function, *Neuroendocrinology* 77:273, 2003.
96. **Flaws JA, De Santi A, Tilly KI, Javid RO, Kugu K, Johnson AL, Hirshfield AN, Tilly JL**, Vasoactive intestinal peptide-mediated suppression of apoptosis in the ovary: potential mechanisms of action and evidence of a conserved antiapoptotic role through evolution, *Endocrinology* 136:4351, 1995.
97. **Mayerhofer A, Dissen GA, Costa ME, Ojeda S**, A role for neurotransmitters in early follicular development: induction of functional follicle-stimulating hormone receptors in newly formed follicles of the rat ovary, *Endocrinology* 138:3320, 1997.
98. **Ricu M, Paredes A, Greiner M, Ojeda SR, Lara HE**, Functional development of the ovarian noradrenergic innervation, *Endocrinology* 149:50, 2008.
99. **Gougeon A**, Dynamics of follicular growth in the human: a model from preliminary results, *Hum Reprod* 1:81, 1986.
100. **Gougeon A**, Regulation of ovarian follicular development in primates: facts and hypotheses, *Endocr Rev* 17:121, 1996.
101. **Zheng W, Magid MS, Kramer EE, Chen YT**, Follicle-stimulating hormone receptor is expressed in human ovarian surface epithelium and fallopian tube, *Am J Pathol* 148:47, 1996.
102. **Speert H**, *Obstetric & Gynecologic Milestones Illustrated*, The Parthenon Publishing Group, New York, 1996.
103. **Lawrence TS, Dekel M, Beers WH**, Binding of human chorionic gonadotropin by rat cumuli, oophori and granulosa cells: a comparative study, *Endocrinology* 106:1114, 1980.
104. **Adashi EY**, Cytokine-mediated regulation of ovarian function: encounters of a third kind, *Endocrinology* 124:2043, 1989.
105. **Krishna A, Beesley K, Terranova PF**, Histamine, mast cells and ovarian function, *J Endocrinol* 120:363, 1989.

# The Uterus, Endometrial Physiology, and Menstruation

Anatomic knowledge of the uterus was slow to accumulate.<sup>1,2</sup> Papyrus writings from 2500 B.C. indicate that the ancient Egyptians made a distinction between the vagina and uterus. Because the dead had to be embalmed, dissection was precluded, but prolapse was recognized because it was important to return the uterus into its proper place prior to mummification. Next to the Egyptian papyri in antiquity were Hindu writings in which descriptions of the uterus, tubes, and vagina indicate knowledge gained from dissections. This was probably the earliest description of the fallopian tubes.

There is little information in Greek writings about female anatomy; however, Herophilus (fourth century B.C.), the great anatomist in Alexandria and the originator of scholarly dissection, recorded the different positions of the uterus. Soranus of Ephesus (98–138 A.D.) accurately described the uterus (probably the first to do so), obviously from multiple dissections of cadavers. He recognized that the uterus is not essential for life, acknowledged the presence of leiomyomas, and treated prolapse with pessaries.

Herophilus and Soranus were uncertain about the function of the fallopian tubes, but Galen, Rufus, and Aetisu correctly guessed their function. Galen promoted the practice of bleeding for the treatment of almost every disorder. In his argument that nature prevented disease by discharging excess blood, Galen maintained that women were healthier because their superfluous blood was eliminated by menstruation.<sup>3</sup> The writings of Galen (130–200 A.D.) represented the knowledge of medicine for over 1,000 years until the end of the medieval Dark Ages. Galen's description of the uterus and tubes indicates that he had only seen the horned uteri of animals.

In the 16th century, Berengarius, Vesalius, Eustachius, and Fallopius made significant contributions to the anatomic study of the female genitalia. Berengarius (Giacomo Berengario da Carpi) was the first anatomist to work with an artist. His anatomic text, published in 1514, depicted dissected subjects as if they were still alive.

Gabriele Fallopio (or Fallopius) published his work, *Observationes Anatomicae*, in Venice in 1561, 1 year before his death from pleurisy at age 40. He provided the first descriptions of the clitoris and the hymen and the first exact descriptions of the ovaries and the tubes. He named the vagina and the placenta and called the tubes the uteri tuba (the trumpet of the uterus), but soon they were known universally as the fallopian tubes.



It was his professor and mentor at the University of Padua, however, Andreas Vesalius, who was the first to accurately reveal the presence of the endometrial cavity.

# DEVELOPMENT OF THE MÜLLERIAN SYSTEM

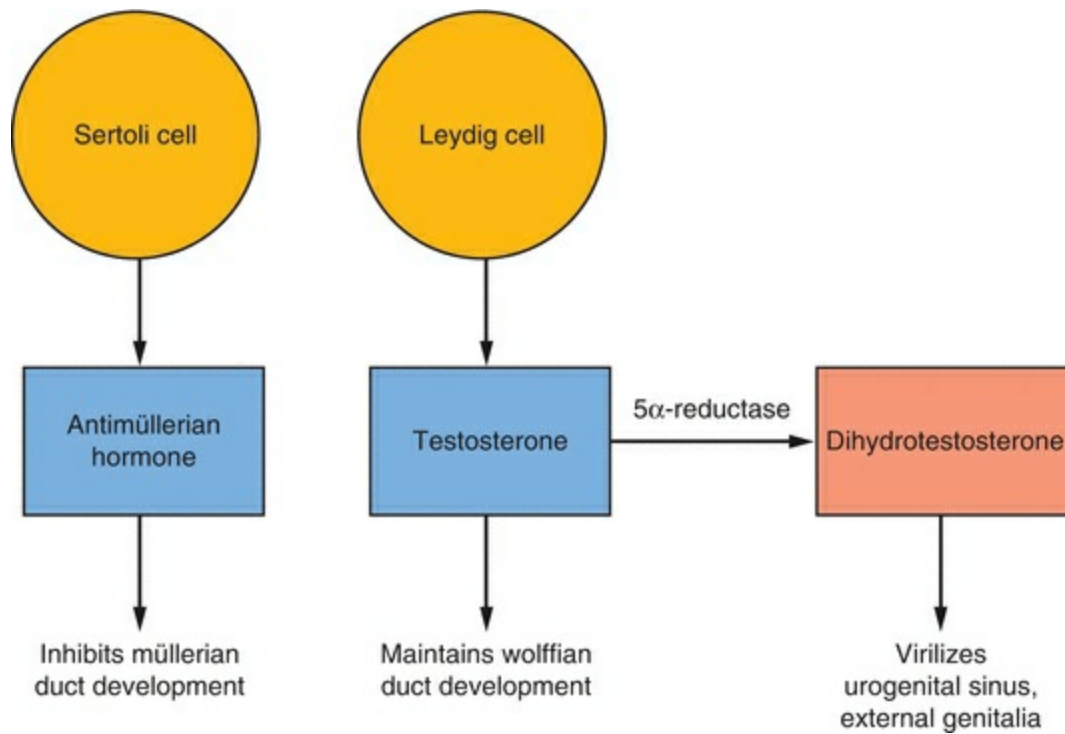
---

The Wolffian (mesonephric) and müllerian (paramesonephric) ducts are discrete primordia that temporarily coexist in all embryos during the ambisexual period of development (up to 8 weeks). Thereafter, one type of duct system persists normally and gives rise to special ducts and glands, whereas the other disappears during the 3rd fetal month, except for nonfunctional vestiges.

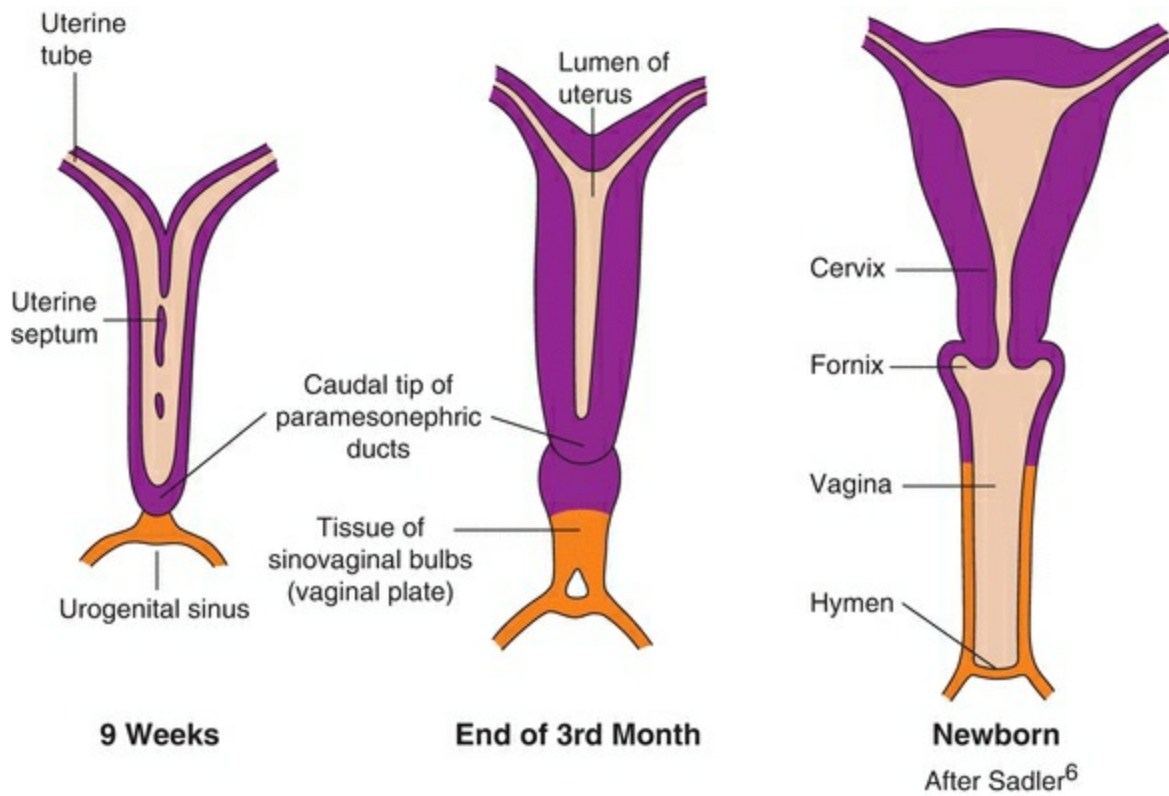
Hormonal control of mammalian somatic sex differentiation was established by the classic experiments of Alfred Jost.<sup>4</sup> In Jost's landmark studies, the active role of male-determining factors, as opposed to the constitutive nature of female differentiation, was defined as the directing feature of sex differentiation. This principle applies not only to the internal ducts but to the gonad, the external genitalia, and even the brain. The critical factors in determining which of the duct structures stabilize or regress are the secretions from the testes: AMH (antimüllerian hormone, also known as müllerian-inhibiting substance or müllerian-inhibiting factor) and testosterone.

The internal genitalia possess the intrinsic tendency to feminize. In the absence of a Y chromosome and a functional testis, the lack of AMH allows retention of the müllerian system and development of fallopian tubes, uterus, and upper vagina. In the absence of testosterone, the Wolffian system regresses. In the presence of a normal ovary or the absence of any gonad, müllerian duct development takes place. This process is discussed in greater detail in [Chapter 8](#).

AMH is a member of the transforming growth factor- $\beta$  (TGF- $\beta$ ) family of glycoprotein differentiation factors that include inhibin and activin. During fetal development, AMH shows a sex-dimorphic expression pattern as it is only expressed by the fetal testis but not ovary. AMH is synthesized by Sertoli cells soon after testicular differentiation and acts upon their respective type II receptors located on the surface of the müllerian ducts resulting in their ipsilateral regression by 8 weeks. Mutations in the AMH gene, located on chromosome 19p13.3, cause persistent müllerian duct syndrome (PMDS), characterized by the presence of a uterus, fallopian tubes, and the upper part of the vagina in otherwise phenotypically normal males.<sup>5</sup> In the absence of AMH, the fetus will develop fallopian tubes, uterus, and upper vagina from the paramesonephric ducts (the müllerian ducts). This development requires the prior appearance of the mesonephric ducts, and for this reason, abnormalities in the development of the tubes, uterus, and upper vagina are associated with abnormalities in the renal system ([Figures 3.1 and 3.2](#)).<sup>6</sup>



**FIGURE 3.1**



**FIGURE 3.2**

In the late fetal life of human, the sex-dimorphic AMH expression pattern is lost as AMH begins to be produced by the granulosa cells within the ovary, the timing of which is well-coordinated since müllerian duct differentiation is complete by this point. For many years, the function of AMH was thought to be restricted to in utero fetal sexual differentiation until the late 20th century, when other discoveries revealed that AMH plays an important role in postnatal ovarian biology, transforming the field of clinical reproductive medicine.<sup>7</sup> The role of AMH in female ovarian biology is discussed in [Chapter 5](#) in greater detail.

The paramesonephric ducts come into contact in the midline to form a Y-shaped structure, the primordium for the uterus, tubes, and the upper approximately one-third of the vagina.<sup>8</sup> The fallopian tubes, the uterus, and the upper portion of the vagina are created by the fusion of the müllerian ducts by the 10th week of gestation. Canalization to create the uterine cavity, the cervical canal, and the vagina is complete by the 22nd week of gestation. Under the epithelium lies mesenchymal tissue that will be the origin of the uterine stroma and smooth muscle cells. By the 20th week of pregnancy, the uterine mucosa is fully differentiated into the endometrium.

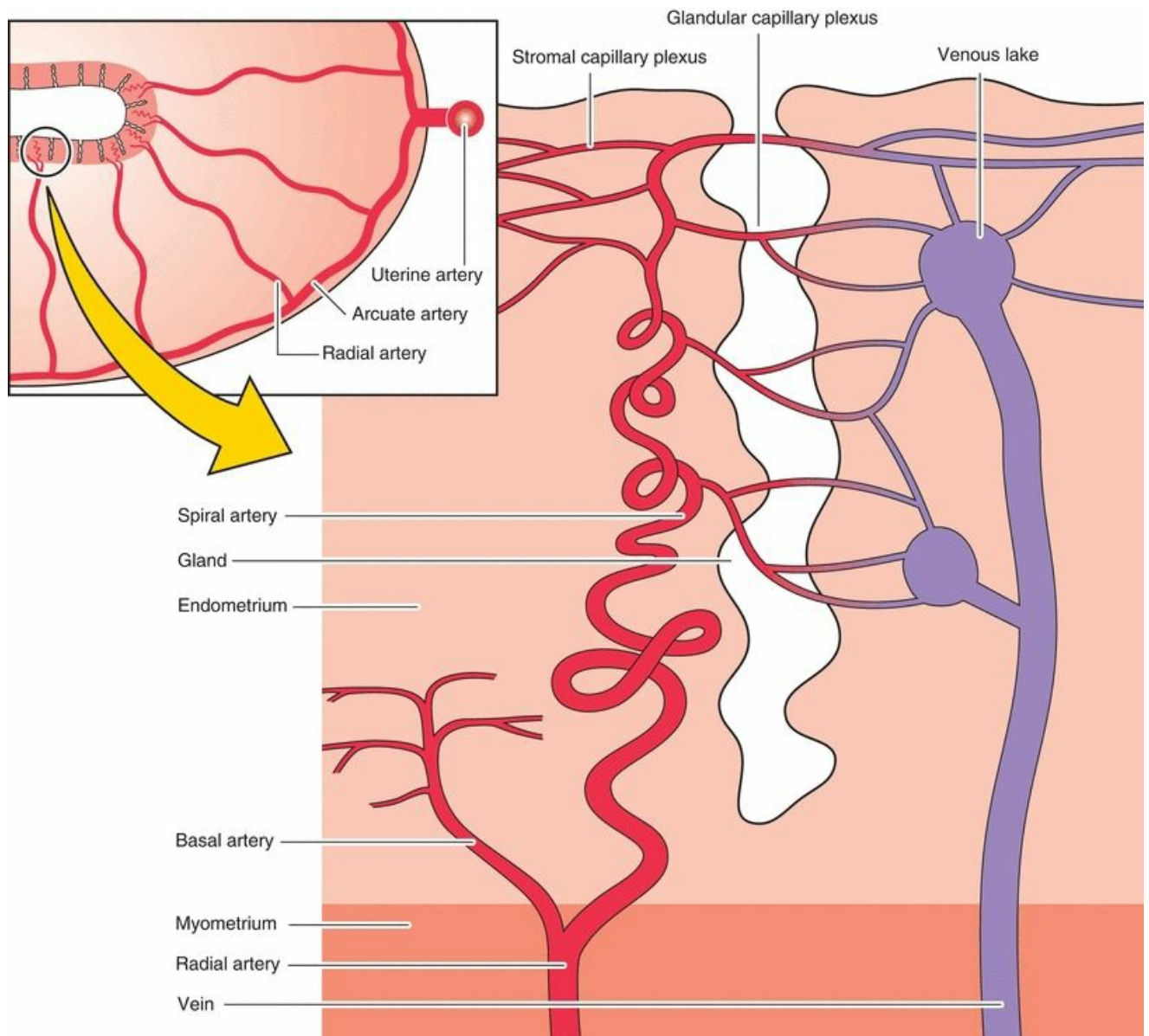
The endometrium, derived from the mucosal lining of the fused müllerian ducts, is essential for reproduction and may be one of the most complex tissues in the human body. It is always changing, responding to the cyclic patterns of estrogen and progesterone of the ovarian menstrual cycle and to a complex interplay among its own autocrine and paracrine factors.

# THE HISTOLOGIC CHANGES IN THE ENDOMETRIUM DURING AN OVULATORY CYCLE

---

The sequence of endometrial changes associated with an ovulatory cycle has been carefully studied by Noyes in the human and Bartlemez and Markee in the subhuman primate.<sup>9,10,11,12,13</sup> From these data, a description of menstrual physiology has been developed based on specific anatomic and functional changes within glandular, vascular, and stromal components of the endometrium.<sup>14,15,16</sup> These changes will be discussed in five phases: (1) the menstrual endometrium, (2) the proliferative phase, (3) the secretory phase, (4) the preparation for implantation, and (5) finally, the phase of endometrial breakdown. Although these distinctions are not entirely arbitrary, it must be recalled that the entire process is an integrated evolutionary cycle of endometrial growth and regression, which is repeated some 400 times during the adult life of the human female.

The endometrium can be divided morphologically into an upper two-thirds “functionalis” layer and a lower one-third “basalis” layer. The purpose of the functionalis layer is to prepare for the implantation of the blastocyst; therefore, it is the site of proliferation, secretion, and degeneration. The purpose of the basalis layer is to provide the regenerative endometrium following menstrual loss of the functionalis<sup>17</sup> (**Figure 3.3**).



**FIGURE 3.3**

# The Uterine Vasculature

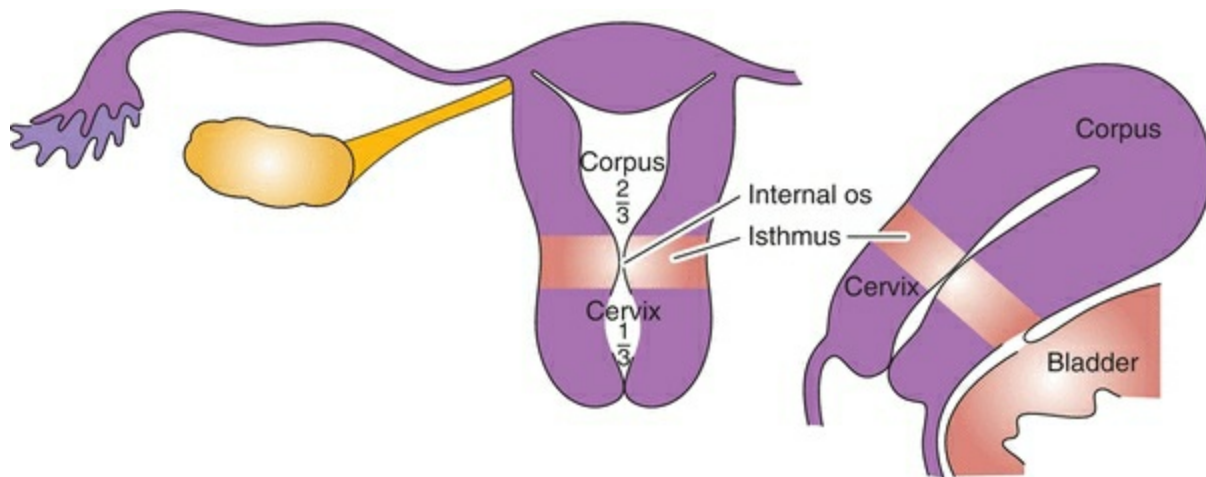
The two uterine arteries that supply the uterus are branches of the internal iliac arteries. At the lower part of the uterus, the uterine artery separates into the vaginal artery and an ascending branch that divides into the arcuate arteries. The arcuate arteries run parallel to the uterine cavity and anastomose with each other, forming a vascular ring around the cavity. Small centrifugal branches (the radial arteries) leave the arcuate vessels, perpendicular to the endometrial cavity, to supply the myometrium. When these arteries enter the endometrium, small branches (the basal arteries) extend laterally to supply the basalis layer. These basal arteries do not demonstrate a response to hormonal changes. The radial arteries continue in the direction of the endometrial surface, now assuming a corkscrew appearance (and now called the spiral arteries), to supply the functionalis layer of the endometrium. It is the spiral artery (an end artery) segment that is very sensitive to hormonal changes. One reason that the functionalis layer is more vulnerable to vascular ischemia is that there are no anastomoses among the spiral arteries. The endometrial glands and the stromal tissue are supplied by capillaries that emerge from the spiral arteries at all levels of the endometrium. The capillaries drain into a venous plexus and eventually into the myometrial arcuate veins and into the uterine veins. This unique vascular architecture is important in allowing a repeated sequence of endometrial growth and desquamation.

# The Menstrual Endometrium

The menstrual endometrium is a relatively thin but dense tissue. It is composed of the stable, basalis component and a variable, but small, amount of residual stratum spongiosum. At menstruation, this latter tissue displays a variety of functional states including disarray and breakage of glands, fragmentation of vessels and stroma with persisting evidence of necrosis, white cell infiltration, and red cell interstitial diapedesis. Even as the remnants of menstrual shedding dominate the overall appearance of this tissue, evidence of repair in all tissue components can be detected. Endometrial regeneration originates in epithelial and stromal stem cells. The first evidence for the existence of adult stem cells in the endometrium was provided in 2004. It was reported by the group of Taylor at Yale that some epithelial cells and stromal cells of human endometrium in HLA-antigen-mismatched bone marrow transplant recipients were of donor origin.<sup>7</sup> Concurrently, the group of Caroline Gargett showed rare clonogenic cell populations in purified populations of human endometrial epithelial and stromal cells isolated from hysterectomy tissues.<sup>8</sup> Since then, adult endometrial stem cells have been further characterized in humans and animal models. Endometrial epithelial stem cells have been found in glands within the basalis layer and are thought to be responsible for the reepithelialization of the exposed surface of the endometrium and subsequent glandular proliferation to regenerate the functionalis layer under the influence of increasing estrogen levels following menses.<sup>19</sup> Endometrial mesenchymal stem/progenitor cells are found around blood vessels in the basalis layer. These progenitor cells are thought to contribute to regeneration and growth of the endometrial functionalis stroma.<sup>19</sup>

The menstrual endometrium is a transitional state bridging the more dramatic proliferative and exfoliative phases of the cycle. Its density implies that the shortness of height is not entirely due to desquamation. Collapse of the supporting matrix also contributes significantly to the shallowness. Reticular stains in rhesus endometrium confirm this “deflated” state (**Figure 3.4**). Nevertheless, as much as two-thirds of the functioning endometrium is lost during menstruation. The more rapid the tissue loss, the shorter the duration of flow. Delayed or incomplete shedding is associated with heavier flow and greater blood loss.





**FIGURE 3.4**

DNA synthesis is occurring in those areas of the basalis that have been completely denuded by days 2–3 of the menstrual cycle (the endometrium in the isthmic area, the narrow area between the cervix and the corpus, and the endometrium in the cornual recesses at the ostia of the tubes remain intact). The new surface epithelium emanates from the flanks of stumps of glands in the basalis layer left standing after menstrual desquamation.<sup>20</sup> Rapid re-epithelialization follows the proliferation of the cells in the basalis layer and the surface epithelium in the isthmic and tubal ostial endometrium. This epithelial repair is supported by underlying fibroblasts and stem cells. The stromal fibroblast layer forms a compact mass over which the resurfacing epithelium can “migrate.” In addition, it is likely that the stromal layer contributes important autocrine and paracrine factors for growth and migration. Because hormone levels are at their nadir during this repair phase, the response may be due to injury rather than hormone mediated. However, the basalis layer is rich in its content of estrogen receptors. This “repair” is fast; by day 4 of the cycle, more than two-thirds of the cavity is covered with new epithelium.<sup>20</sup> By days 5–6, the entire cavity is re-epithelialized, and stromal growth begins.

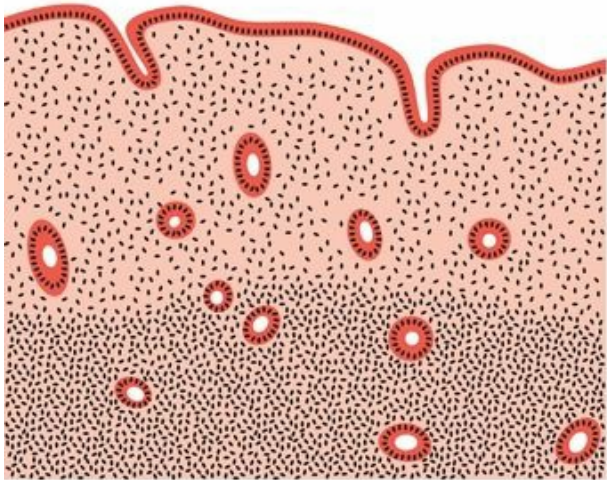
## The Proliferative Phase

The proliferative phase is associated with ovarian follicle growth and increased estrogen secretion. Undoubtedly as a result of this steroidal action, reconstruction and growth of the endometrium are achieved. The glands are most notable in this response. At first, they are narrow and tubular, lined by low columnar epithelium cells. Mitoses become prominent, and pseudostratification is observed. As a result, the glandular epithelium extends peripherally and links one gland segment with its immediate neighbor. A continuous epithelial lining facing the endometrial cavity is formed. The stromal component evolves from its dense cellular menstrual condition through a brief period of edema to a final loose syncytial-like status. Coursing through the stroma, spiral vessels extend (unbranched and uncoiled in the early proliferative phase) to a point immediately below the epithelial binding membrane. Here, they form a loose capillary network. All of the tissue components (glands, stromal cells, and endothelial cells) demonstrate proliferation, which peaks on days 8–10 of the cycle, reflecting rising estradiol levels in the circulation and maximal estrogen receptor concentration in the endometrium.<sup>21</sup> This proliferation is marked by increased mitotic activity and increased nuclear DNA and cytoplasmic RNA synthesis, which is most intense in the functionalis layer in the upper two-thirds of the uterus, the usual site of blastocyst implantation.

During proliferation, the endometrium grows from approximately 0.5 mm to 3.5–6.0 mm in height of each singular apposed layer, corresponding to the trilaminar endometrium seen on ultrasound imaging; this image includes endometrium originating from both sides of the uterus and the junction of the two. Restoration of tissue constituents has been achieved by estrogen-induced new growth as well as incorporation of ions, water, and amino acids. The stromal ground substance has reexpanded from its menstrual collapse. Although true tissue growth has occurred, a major element in the achievement of endometrial height is “re-inflation” of the stroma. Factors that regulate the limits of endometrial growth are not well defined. While estrogen exposure is necessary, normal endometrial growth reaches its peak by cycle days 9–10, a time when estradiol levels have not yet reached its peak.<sup>22</sup> The factors that limit endometrial growth remain to be characterized.

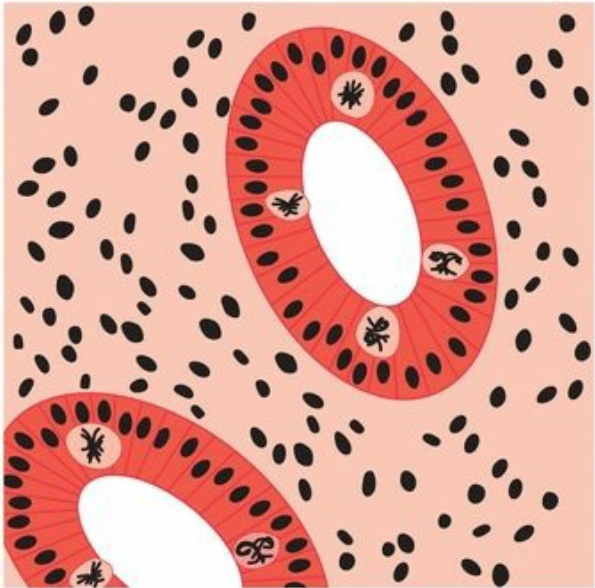
An important feature of this estrogen-dominant phase of endometrial growth is the increase in ciliated and microvillous cells. Ciliogenesis begins on days 7–8 of the cycle.<sup>20</sup> This response to estrogen is exaggerated in hyperplastic endometrium that is the result of hyperestrogenism. The concentration of these ciliated cells around gland openings and the ciliary beat pattern influence the mobilization and distribution of endometrial secretions during the secretory phase (**Figure 3.5**). Cell surface microvilli, also a response to estradiol, are cytoplasmic extensions and serve to increase the active

surface of cells.

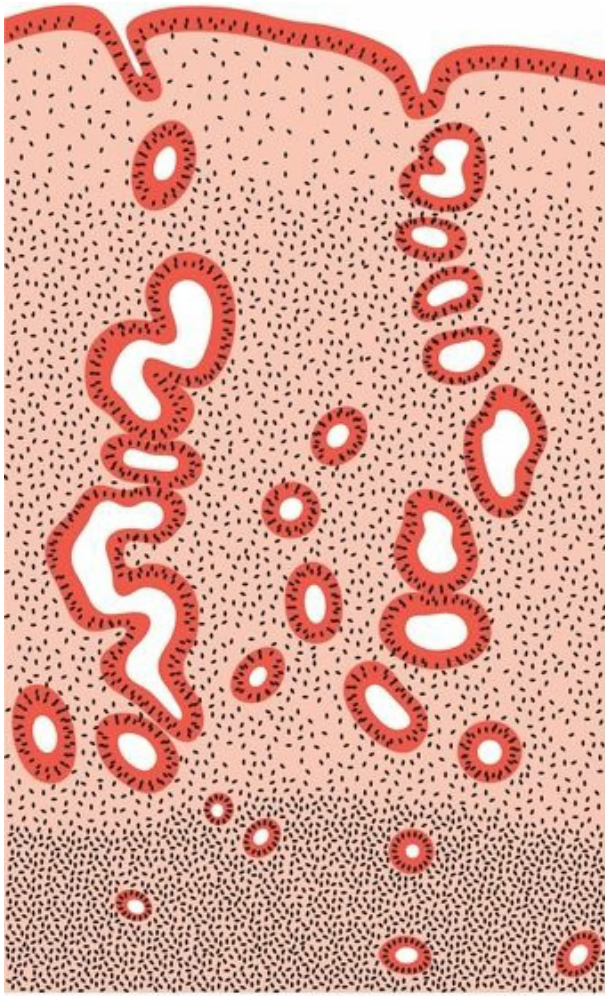


Early Proliferative

**FIGURE 3.5**



At all times, a large number of hematopoietic cells derived from the bone marrow are present in the endometrium. These include lymphocytes and macrophages, diffusely distributed in the stroma (**Figure 3.6**).

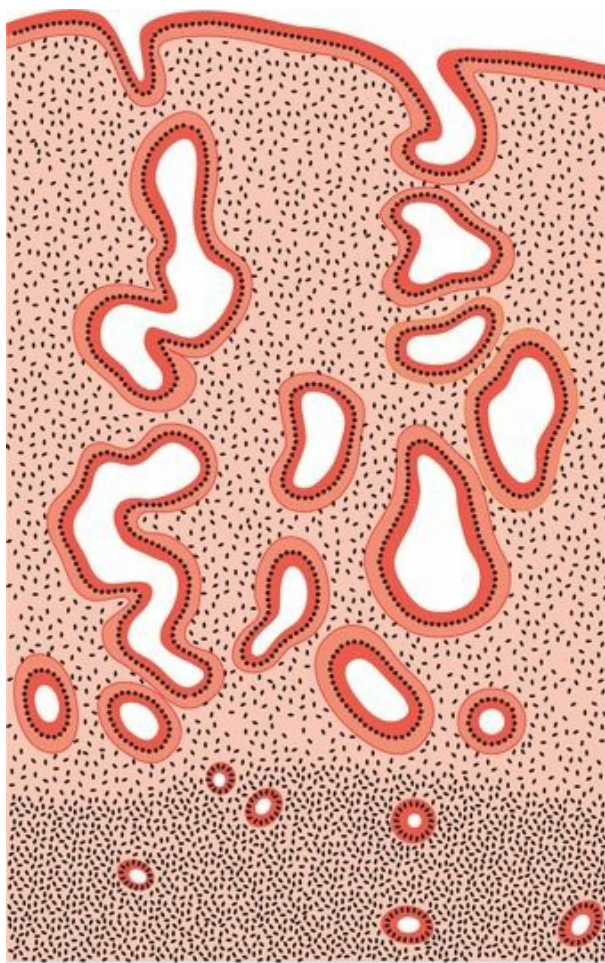


Late Proliferative

**FIGURE 3.6**

# The Secretory Phase

After ovulation, the endometrium now demonstrates a combined reaction to estrogen and progesterone activity (**Figure 3.7**). Most impressive is that total endometrial height is fixed at roughly its preovulatory extent (5–6 mm) despite continued availability of estrogen. Epithelial proliferation ceases 3 days after ovulation.<sup>23</sup> Progesterone receptor expression in endometrial cells is stimulated by rising estrogens in the follicular phase via estrogen receptor- $\alpha$  (ER- $\alpha$ ), leading to augmented progesterone responsiveness during the luteal phase.<sup>24</sup> Conversely, ER- $\alpha$  expression in endometrial cells is inhibited by progesterone via progesterone receptors.<sup>25</sup>



Early Secretory



**FIGURE 3.7**

Progesterone action is central to the changes that the endometrium undergoes in the secretory phase, which are geared toward preparing it for embryo implantation. Differential effects of progesterone on endometrial epithelial and stromal cells are

thought to be due to cell type-specific differences in PR-A and PR-B expression and function. PR-A and PR-B are present in endometrial epithelium during the proliferative phase and increase with rising estrogen levels, consistent with the known induction of PR expression by estrogen. In the endometrial epithelial compartment, PR-A levels decline toward the end of the secretory phase, whereas PR-B levels remain constant, suggesting that PR-B plays a role in the control of glandular secretion. In the stromal cell compartment, in contrast, PR-A is the predominant isoform throughout the menstrual cycle, which likely reflects the requirement for prolonged progesterone-PR-A signaling in this compartment to support decidualization and the establishment of pregnancy.<sup>26,27</sup>

The action of progesterone in the uterus has been revealed through studies utilizing PR antagonists such as mifepristone (RU486) for emergency contraception as well as knockout mice. Administration of RU486 at low doses in the mid or late follicular phase causes infertility by delaying endometrial maturation, while it delays the LH surge and inhibits ovulation at higher doses.<sup>28,29</sup> If administered during pregnancy, it induces abortion, fetal loss, or parturition depending on the gestational age.<sup>30,31</sup>

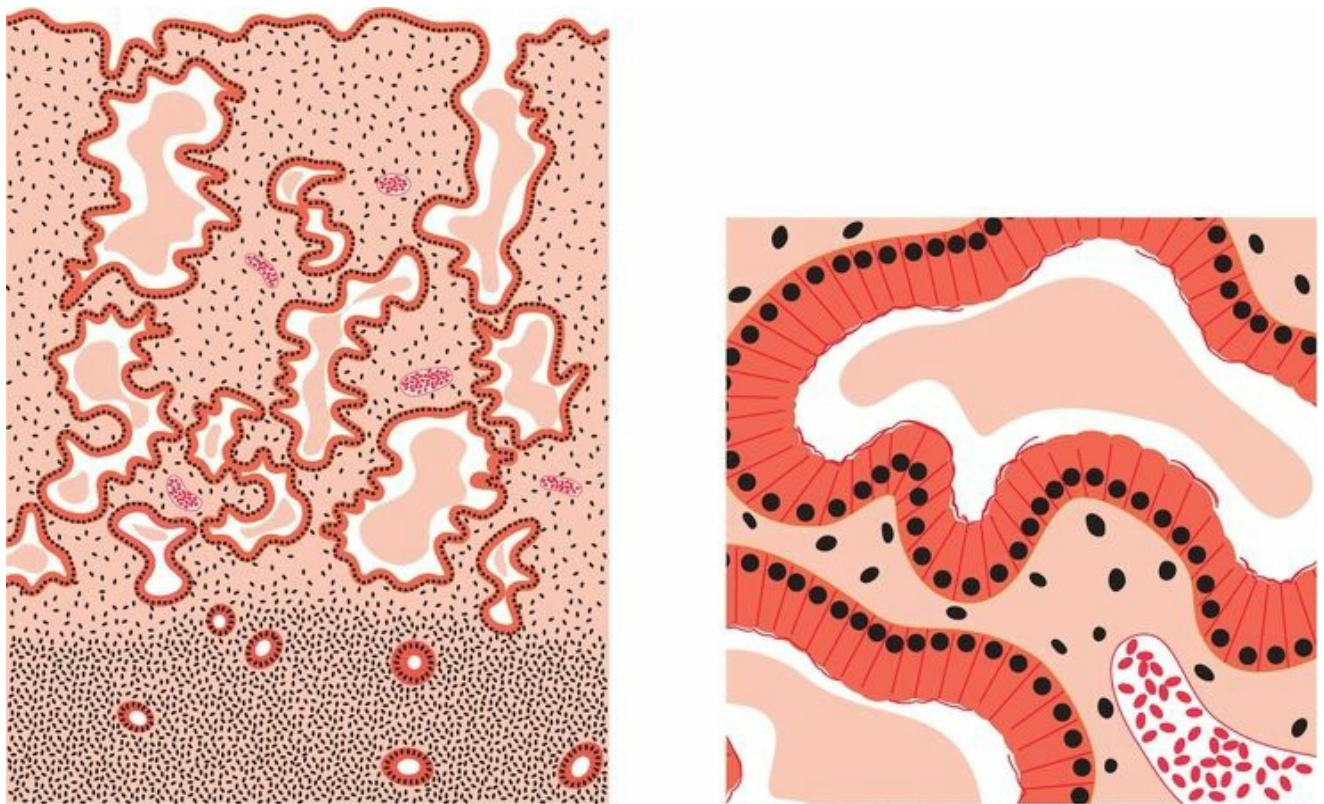
Genetic mouse models harboring defects in PR expression have been instrumental in dissecting the crucial roles of PRs in mediating progesterone actions on the uterus. Mice with global PR knockout are infertile due to defects in ovulation and implantation. Their endometrium is characterized by hypertrophy and inflammation of the glandular epithelium and failure to undergo decidualization.<sup>32</sup> Mice with PR-B-specific knockout, however, have normal ovarian function, implantation, pregnancy, and parturition, suggesting that PR-A is sufficient for normal uterine function.<sup>33</sup> PR-A-null mice exhibit endometrial epithelial hyperplasia and inflammation, and no decidualization in the endometrial stroma,<sup>34</sup> suggesting that PR-A is critical for normal function of the endometrial epithelium and stroma and that PR-B functions to promote hyperplasia of the epithelium, an effect which is repressed by PR-A.

The progesterone-induced limitation of growth is associated with a decline in mitosis and DNA synthesis, significantly due to progesterone interference with estrogen receptor expression and progesterone stimulation of 17 $\beta$ -hydroxysteroid dehydrogenase and sulfotransferase, which convert estradiol to estrone sulfate (which is rapidly excreted from the cell).<sup>35,36</sup> In addition, estrogen stimulates many oncogenes that probably mediate estrogen-induced growth. Progesterone antagonizes this action by suppressing the estrogen-mediated transcription of oncogene mRNA.<sup>37</sup>

Individual components of the tissue continue to display growth, but confinement in a fixed structure leads to progressive tortuosity of glands and intensified coiling of the spiral vessels. The secretory events within the glandular cells, with progression of vacuoles from intracellular to intraluminal appearance, are well known and take place over a 7-day postovulatory interval. At the conclusion of these events, the glands appear

exhausted, the tortuous lumina variably distended, and individual cell surfaces fragmented in a sawtooth appearance. Stroma is increasingly edematous, and spiral vessels are prominent and densely coiled.

The first histologic sign that ovulation has occurred is the appearance of subnuclear intracytoplasmic glycogen vacuoles in the glandular epithelium on cycle days 17–18 (**Figure 3.8**). Giant mitochondria and the “nucleolar channel system” appear in the gland cells. The nucleolar channel system has a unique appearance due to progesterone, an infolding of the nuclear membranes. These structural alterations are soon followed by active secretion of glycoproteins and peptides into the endometrial cavity. Transudation of plasma also contributes to the endometrial secretions. Important immunoglobulins are obtained from the circulation and delivered to the endometrial cavity by binding proteins produced by the epithelial cells. The peak secretory level is reached 7 days after the midcycle gonadotropin surge, coinciding with the time of blastocyst implantation.



Late Secretory

**FIGURE 3.8**

# The Implantation Phase

Significant changes occur within the endometrium from the 7th to the 13th day of postovulation (days 21–27 of the cycle). At the onset of this period, the distended tortuous secretory glands have been most prominent with little intervening stroma. By 13 days of postovulation, the endometrium has differentiated into three distinct zones. Something less than one-fourth of the tissue is the unchanged basalis fed by its straight vessels and surrounded by indifferent spindle-shaped stroma. The midportion of the endometrium (approximately 50% of the total) is the lace-like **stratum spongiosum**, composed of loose edematous stroma with tightly coiled but ubiquitous spiral vessels and exhausted dilated glandular ribbons. Overlying the spongiosum is the superficial layer of the endometrium (about 25% of the height) called the **stratum compactum**. Here, the prominent histologic feature is the stromal cell, which has become large and polyhedral. In its cytoplasmic expansion, one cell abuts the other, forming a compact, structurally sturdy layer. The necks of the glands traversing this segment are compressed and less prominent. The subepithelial capillaries and spiral vessels are engorged.

At the time of implantation, on days 21–22 of the cycle, the predominant morphologic feature is edema of the endometrial stroma. This change may be secondary to the estrogen- and progesterone-mediated increase in prostaglandin and vascular endothelial growth factor (VEGF) production by the endometrium that cause an increase in capillary permeability. Receptors for the sex steroids are present in the muscular walls of the endometrial blood vessels, and the enzyme system for prostaglandin synthesis is present in both the muscular walls and the endothelium of the endometrial arterioles. Mitoses are first seen in endothelial cells on cycle day 22. Vascular proliferation leads to the coiling of the spiral vessels, a response to the sex steroids, the prostaglandins, and the autocrine and paracrine factors produced in response to estrogen and progesterone.

During the secretory phase, ovulation and rising ovarian P4 production promote a marked increase in leukocyte numbers, reaching up to 40% of all endometrial cells in the mid-late secretory phase of the menstrual cycle. This gain in leukocyte numbers is primarily due to the accumulation of uterine natural killer (uNK) cells, reaching a peak concentration in the first trimester of pregnancy. These are specialized granulocytes that have an immunoprotective role in implantation and placentation. Their role in promoting decidual spiral artery vascular remodeling has been recently recognized, which may have important implications for pregnancy pathologies.<sup>38</sup> They are located perivascularly and are believed to be derived from the blood. By days 26–27, the endometrial stroma is infiltrated by many leukocytes, the majority of which are natural killer cells and macrophages, believed to be involved in the process of endometrial breakdown and menstruation. The appearance and function of these cells are regulated



by the complex array of peptides and cytokines in the endometrium in response to hormonal signaling. In addition to uNK cells and macrophages, the endometrium contains scattered T cells with no apparent cycle-dependent changes and uterine dendritic cells (uDCs), which are rare in the luteal endometrium but more abundant in the decidua of pregnancy.<sup>39</sup>

The gene expression pattern in the endometrium throughout the menstrual cycle is being established, with a focus on the implantation window.<sup>40,41,42,43,44</sup> As expected, microarray analyses reveal a changing pattern of gene expression that correlates with each hormonal and morphologic stage in the endometrial menstrual cycle.<sup>45</sup> Ultimately, this will yield a comprehensive picture, with the gene signature of each event in the estrogen and progesterone regulation of the endometrium. The regulating growth factors, cytokines, and peptide hormones that are essential for implantation as well as the aberration in their expression, which may underlie endometrial pathologies such as recurrent implantation failure, will be identified.

The stromal cells of the endometrium respond to hormonal signals, synthesize prostaglandins, and, when transformed into decidual cells, produce an impressive array of substances, some of which are prolactin, relaxin, renin, insulin-like growth factors (IGFs), and insulin-like growth factor-binding proteins (IGFBPs). The endometrial stromal cells, the progenitors of decidual cells, were originally suggested to be derived from the bone marrow (from cells invading the endometrium during fetal life), but they were later considered to originate from the primitive uterine mesenchymal stem cells.<sup>46</sup> More recent evidence from humans and animal models supports the notion that at least some of these endometrial stromal cells are derived from adult bone marrow progenitors.<sup>18,47,48,49</sup> Interestingly, recent evidence in mice suggests that a substantial population of decidual cells is derived from adult bone marrow progenitors and that this nonhematopoietic contribution of bone marrow may be important to implantation and pregnancy.<sup>50</sup>

The decidualization process begins in the luteal phase under the influence of progesterone and mediated by autocrine and paracrine factors. On cycle days 22–23, predecidual cells can be identified, initially surrounding blood vessels, characterized by cytonuclear enlargement, increased mitotic activity, and the formation of a basement membrane. The decidua, derived from stromal cells, becomes an important structural and biochemical tissue of pregnancy. Decidual cells control the invasive nature of the trophoblast, and the products of the decidua play important autocrine and paracrine roles in fetal and maternal tissues. This is discussed in greater detail in [Chapter 7](#).

Decidual cells play a key role in both the process of endometrial bleeding (menstruation) and the process of endometrial hemostasis (implantation and placentation).<sup>51,52,53</sup> Implantation requires endometrial hemostasis and the maternal

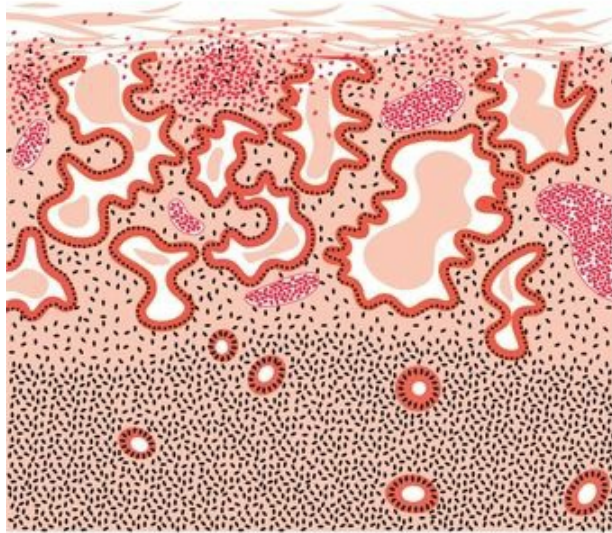
uterus requires resistance to invasion. Inhibition of endometrial hemorrhage can be attributed, to a significant degree, to appropriate changes in critical factors as a consequence of decidualization, for example, lower plasminogen activator levels, reduced expression of the enzymes that degrade the stromal extracellular matrix (such as the metalloproteinases), and increased levels of plasminogen activator inhibitor-1 (PAI-1). Withdrawal of estrogen and progesterone support, however, leads to changes in the opposite directions, consistent with endometrial breakdown.

# The Phase of Endometrial Breakdown

Predecidual transformation has formed the “compacta” layer in the upper part of the functionalis layer by day 25 (3 days before menstruation). In the absence of fertilization and implantation and the consequent lack of sustaining quantities of human chorionic gonadotropin from the trophoblast, the otherwise fixed life span of the corpus luteum is completed, and estrogen and progesterone levels wane.

The withdrawal of estrogen and progesterone initiates important endometrial events: vasomotor reactions, the process of apoptosis, tissue loss, and, finally, menstruation. The most prominent immediate effect of this hormone withdrawal is a modest shrinking of the tissue height and remarkable spiral arteriole vasomotor responses. The classic concept of the vascular sequence was constructed from direct observations of rhesus endometrium transplanted to the anterior chamber of the eye.<sup>9,10</sup> With shrinkage of height, blood flow within the spiral vessels diminished, venous drainage was decreased, and vasodilation ensued. Thereafter, the spiral arterioles underwent rhythmic vasoconstriction and relaxation. Each successive spasm was more prolonged and profound, leading eventually to endometrial blanching. Thus, these reactions were proposed to lead to menstruation because of endometrial ischemia and stasis caused by vasoconstriction of the spiral arterioles. A new model of menstruation, as discussed in [Chapter 15](#), emphasizes enzymatic autodigestion of the functional layer of the endometrium and its capillary plexus.

In the first half of the secretory phase, acid phosphatase and potent lytic enzymes are confined to lysosomes. Their release is inhibited by progesterone stabilization of the lysosomal membranes. With the waning of estrogen and progesterone levels, the lysosomal membranes are not maintained, and the enzymes are released into the cytoplasm of epithelial, stromal, and endothelial cells and eventually into the intercellular space. These active enzymes will digest their cellular constraints, leading to the release of prostaglandins, extravasation of red blood cells, tissue necrosis, and vascular thrombosis. This process is one of **apoptosis** (programmed cell death, characterized by a specific morphologic pattern that involves cell shrinkage and chromatin condensation culminating in cell fragmentation) mediated by cytokines.<sup>54</sup> An important step in this breakdown is the dissolution of cell-to-cell adhesion by key proteins. Binding of endometrial epithelial cells utilizes transmembrane proteins, **cadherins** that link intercellularly with each other and intracellularly with catenins that are bound to actin filaments<sup>55</sup> ([Figure 3.9](#)).



Menstruation



**FIGURE 3.9**

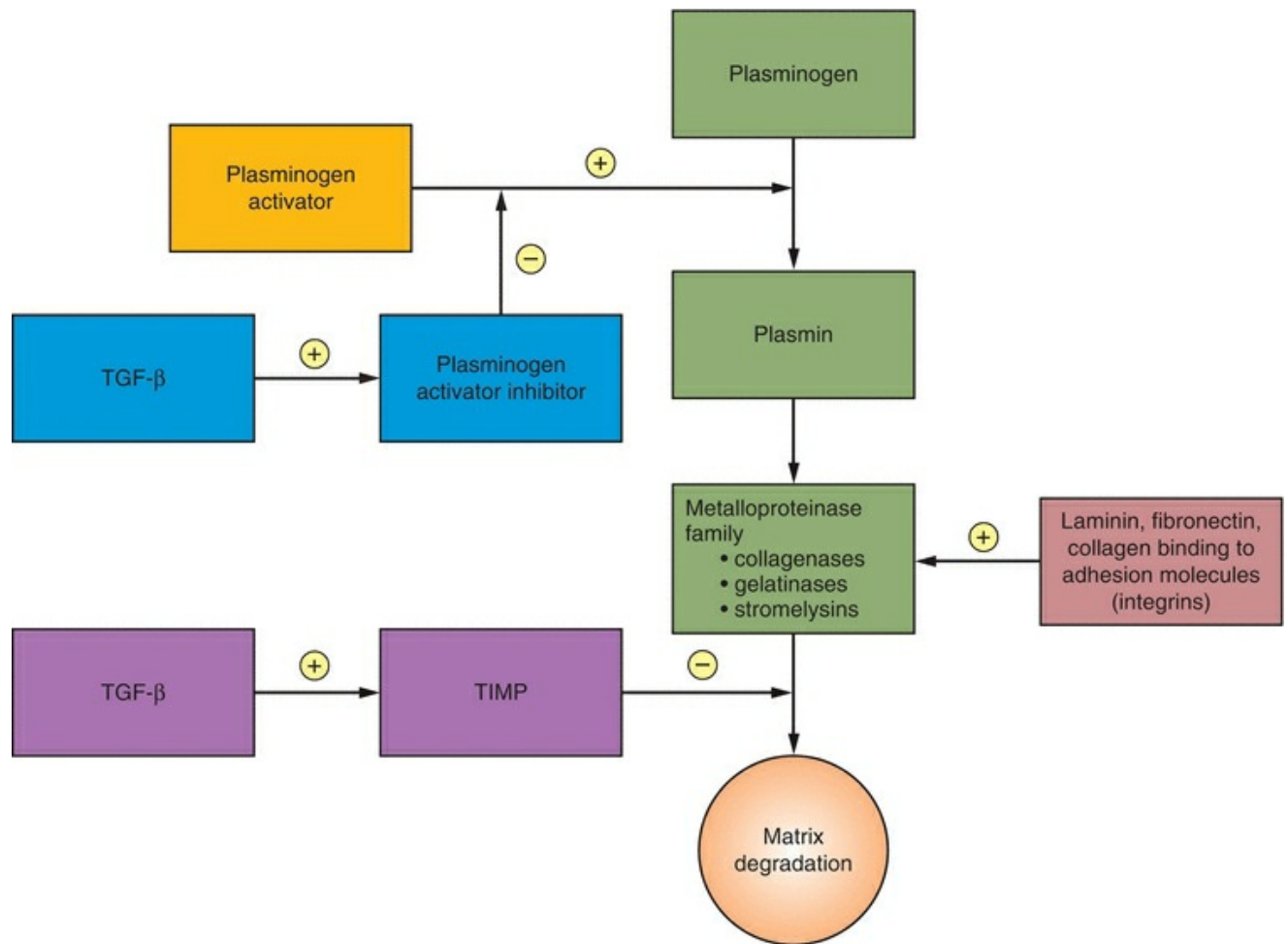
Endometrial tissue breakdown also involves a family of enzymes, matrix metalloproteinases (MMPs), that degrade components (including collagens, gelatins, fibronectin, and laminin) of the extracellular matrix and basement membrane.<sup>56,57</sup> The metalloproteinases include collagenases that degrade interstitial and basement membrane collagens, gelatinases that further degrade collagens, and stromelysins that degrade fibronectin, laminin, and glycoproteins. The expression of metalloproteinases in human endometrial stromal cells follows a pattern correlated with the menstrual cycle, indicating a sex steroid response as part of the growth and remodeling of the endometrium with a marked increase in late secretory and early menstrual endometrium.<sup>58</sup> Progesterone withdrawal from endometrial cells increases VEGF production and induces MMP secretion, probably from both endometrial stromal cells and leukocytes, which is followed by the irreversible breakdown of cellular membranes and the dissolution of extracellular matrix.<sup>59,60,61</sup> Appropriately, this enzyme expression increases in the decidualized endometrium of the late secretory phase, during the time of declining progesterone levels. With the continuing progesterone secretion of early pregnancy, the decidua is maintained, and metalloproteinase expression is suppressed, in a mechanism mediated by TGF- $\beta$ .<sup>62</sup> In a nonpregnant cycle, metalloproteinase expression is suppressed after menses, presumably by increasing estrogen levels.

Metalloproteinase activity is restrained by specific tissue inhibitors designated as tissue inhibitor of metalloprotein (TIMP).<sup>63</sup> The balance of metalloproteinase and TIMP activity is an important event in successful implantation. Thus, progesterone withdrawal

can lead to endometrial breakdown through a mechanism that is independent of vascular events (specifically ischemia), a mechanism that involves cytokines.<sup>54</sup> During bleeding, both normal and abnormal, there is evidence indicating that specific genes are activated in the endometrium; one such gene has the structural features of the TGF- $\beta$  family.<sup>64</sup>

There is considerable evidence to support a major role for a cytokine, tumor necrosis factor- $\alpha$  (TNF- $\alpha$ ), in menstruation.<sup>54</sup> TNF- $\alpha$  is a transmembrane protein whose receptor belongs to the nerve growth factor/TNF family for inducing apoptotic signals. The key change is an increase in secretion because TNF- $\alpha$  secretion by endometrial cells reaches a peak at menstruation, but there is no cycle change in receptor content. TNF- $\alpha$  inhibits endometrial proliferation and induces apoptosis; this cytokine causes a loss of adhesion proteins (the cadherin-catenin-actin complex) and induces cell-to-cell dissolution. In addition to endometrial cells, TNF- $\alpha$  also causes damage to vascular endothelium.

Progesterone withdrawal is also associated with an increase in VEGF receptor concentrations in the stromal cells of the layers of endometrium destined to be sloughed.<sup>65</sup> Although the VEGF system is usually involved with angiogenesis, in this case, these factors are involved in the preparation for menstrual bleeding, perhaps influencing the expression of MMPs. Endometrial genes without classic steroid response elements can respond to the sex steroids either indirectly or by tethering to a family of proteins that mediate transcriptional activity. These proteins, induced by progesterone in stromal (decidual) and epithelial cells, can activate tissue factor (TF), PAI-1, IGF-binding protein-1, uteroglobin, and uteroferrin. TF is involved in the clotting mechanism to sustain hemostasis. Uteroglobin is a small protein expressed in endometrial epithelial cells.<sup>66</sup> The physiologic function of uteroglobin is uncertain. Uteroglobin, with high affinity, binds progestins and may play a role in immunosuppression. Uteroglobin gene expression is stimulated by estrogen, and this response is enhanced by progesterone. Human endometrium can secrete  $\beta$ -endorphin, yet another candidate for involvement in endometrial immunologic events, and its release is inhibited by both estrogens and glucocorticoids<sup>67</sup> (**Figure 3.10**).

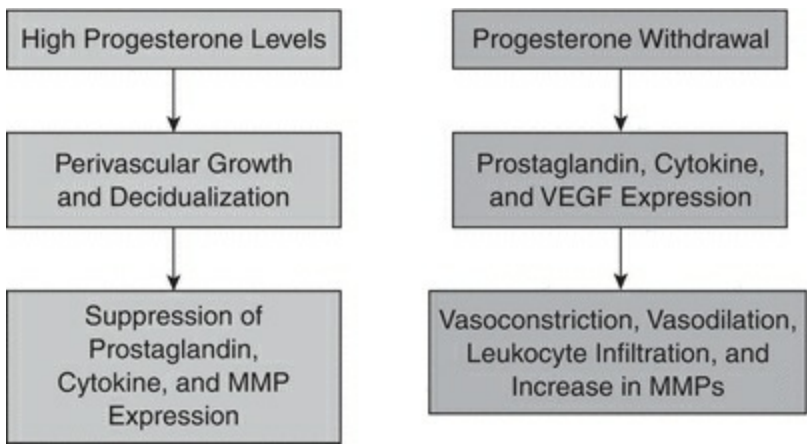


**FIGURE 3.10**

Eventually, considerable leakage occurs as a result of diapedesis, and finally, interstitial hemorrhage occurs due to breaks in superficial arterioles and capillaries. White cells migrate through capillary walls, at first remaining adjacent to vessels but then extending throughout the stroma. The leukocytes add important regulatory cytokines, chemokines, and enzymes that are involved in the degradation of the extracellular matrix. During arteriolar vasomotor changes, red blood cells escape into the interstitial space. Thrombin-platelet plugs also appear in superficial vessels. The prostaglandin content ( $\text{PGF}_2\text{-}\alpha$  and  $\text{PGE}_2$ ) in the secretory endometrium reaches its highest levels at the time of menstruation. The vasoconstriction and myometrial contractions associated with the menstrual events are believed to be significantly mediated by prostaglandins from perivascular cells and the potent vasoconstrictor endothelin-1, derived from stromal decidual cells.

As ischemia and weakening progress, the continuous binding membrane is fragmented, and intercellular blood is extruded into the endometrial cavity. New thrombin-platelet plugs form intravascularly upstream at the shedding surface, limiting

blood loss. Increased blood loss is a consequence of reduced platelet numbers and inadequate hemostatic plug formation. Menstrual bleeding is influenced by activation of clotting and fibrinolysis. Fibrinolysis is principally the consequence of the potent enzyme plasmin, formed from its inactive precursor plasminogen. Endometrial stromal cell TF and plasminogen activators and inhibitors are involved in achieving a balance in this process. TF stimulates coagulation, initially binding to factor VII. TF and PAI-1 expression accompany decidualization, and the levels of these factors may govern the amount of bleeding.<sup>53,68</sup> PAI-1, in particular, exerts an important restraining action on fibrinolysis and proteolytic activity.<sup>69</sup> Blood loss is also controlled by constriction of the spiral arteries, mediated by the perivascular cells, myofibroblasts that surround the spiral arteries.<sup>70</sup> These cells respond to progesterone withdrawal by expressing prostaglandins, cytokines, and MMPs, not only causing cycling vasoconstriction and vasodilation but also modulating leukocyte entry (an important additional source of metalloproteinases) into the endometrium. Disordered growth and function of the perivascular cells are likely contributing factors in menstrual bleeding problems (Figure 3.11).



**FIGURE 3.11**

With progressive enzymatic degradation of the endometrium, the subsurface capillary and venous vascular system is disrupted, causing hemorrhage and escape of blood into the endometrial cavity. Additional ischemic breakdown ensues with necrosis of cells and defects in vessels adding to the menstrual effluvium. Degeneration extends to the deepest extent of the functional layer where rupture of the basal arterioles contributes to bleeding. A natural cleavage point exists between basalis and spongiosum, and, once breached, the loose, vascular, edematous stroma of the spongiosum desquamates and collapses. The process is initiated in the fundus and inexorably extends throughout the uterus. In the end, the typical deflated, shallow, dense, menstrual endometrium results.

Within 13 hours, the endometrial height shrinks from 4 to 1.25 mm.<sup>15</sup> Menstrual flow stops as a result of the combined effects of prolonged vasoconstriction of the radial arteries and the spiral arteries in the basalis, tissue collapse, vascular stasis, and estrogen-induced “healing.” In contrast to postpartum bleeding, myometrial contractions are not important for control of menstrual bleeding. Thrombin generation in the basal endometrium in response to extravasation of blood is essential for hemostasis. Thrombin promotes the generation of fibrin, the activation of platelets and clotting cofactors, and angiogenesis.

The basalis endometrium remains during menses, and repair takes place from this layer. This endometrium is protected from the lytic enzymes in the menstrual fluid by a mucinous layer of carbohydrate products that are discharged from the glandular and stromal cells.<sup>71</sup>



# Normal Menses

Approximately 50% of the menstrual detritus is expelled in the first 24 hours of menstrual flow. The menstrual fluid is composed of the autolyzed functionalis, inflammatory exudate, red blood cells, and proteolytic enzymes (at least one of which, plasmin, lyses fibrin clots as they form). The high fibrinolytic activity advances emptying of the uterus by liquefaction of tissue and fibrin. If the rate of flow is great, clotting can and does occur.

Most women (90%) have menstrual cycles with an interval of 24–35 days ([Chapter 5](#)).<sup>72,73</sup> Menarche is followed by approximately 5–7 years of increasing regularity as cycles shorten to reach the usual reproductive-age pattern. In the 40s, cycles begin to lengthen again. The usual duration of flow is 4–6 days, but many women have flow for as little as 2 days and as much as 8 days. The normal volume of menstrual blood loss is 30 mL; greater than 80 mL is abnormal. Normal and abnormal characteristics and definitions of menstrual flow are discussed in detail in [Chapter 15](#).

# A TELEOLOGIC THEORY OF ENDOMETRIAL-MENSTRUAL EVENTS

---

Menstruation is a very recent phenomenon in the evolutionary time line. It occurs in very few species, even among viviparous animals. An unabashedly teleologic view of menstrual events was offered many years ago by Rock et al.<sup>74</sup> The basic premise of this thesis is that every endometrial cycle has, as its only goal, nourishing support of an early embryo. Failure to accomplish this objective is followed by orderly elimination of unutilized tissue and prompt renewal to achieve a more successful cycle.

The ovum must be fertilized within 12–24 hours of ovulation. Over the next 4 days, it remains unattached within the tubal lumen, utilizing tubal fluids and residual cumulus cells to sustain nutrition and energy for early cellular cleavage. After this stay, the solid ball of cells (morula), which is the embryo, leaves the tube and enters the uterine cavity. Here, the embryo undergoes another 2–3 days of unattached but active existence. Fortunately, by this time, endometrial gland secretions have filled the cavity and they bathe the embryo in nutrients. This is the first of many neatly synchronized events that mark the conceptus-endometrial relationship. By 6 days after ovulation, the embryo (now a blastocyst) is ready to attach and implant. At this time, it finds an endometrial lining of sufficient depth, vascularity, and nutritional richness to sustain the important events of early placentation to follow. Just below the epithelial lining, a rich capillary plexus has been formed and is available for creation of the trophoblast-maternal blood interface. Later, the surrounding zona compactum, occupying more and more of the endometrium, will retain endometrial architecture despite the invasive inroads of the burgeoning trophoblast.

Failure of the appearance of human chorionic gonadotropin, despite otherwise appropriate tissue reactions, leads to the vasomotor changes associated with estrogen-progesterone withdrawal and menstrual desquamation. However, not all the tissue is lost, and, in any event, a residual stem cell containing basalis is always available, making resumption of growth with estrogen a relatively rapid process. Indeed, even as menses persists, early regeneration can be seen. As soon as follicle maturation occurs (in as short a time as 10 days), the endometrium is ready once again to perform its reproductive function.

# **THE UTERUS IS AN ENDOCRINE ORGAN**

---

The uterus is dynamic. It not only responds and changes in a sensitive fashion to classic hormonal signals (the endocrine events of the menstrual cycle), but it is also composed of complex tissues, with important autocrine and paracrine functions that serve not only the uterus but also the contiguous tissues of the fetoplacental unit during pregnancy. The most dynamic component of the uterus is the endometrium.

# Endometrial Products

The endometrium secretes many substances, the functions of which (and their interrelationships) represent a major investigative challenge.<sup>75</sup> In addition to producing a nourishing, supportive environment for the early embryo, the endometrium plays an important role in suppressing the immune response within the pregnant uterus. The mechanisms controlling the immune response and induction of fetal tolerance within the decidua are not well understood, but hormonal influence, decidual cells, NK cells, and regulatory T (Treg) cells along with their downstream array of secretory products are undoubtedly important.

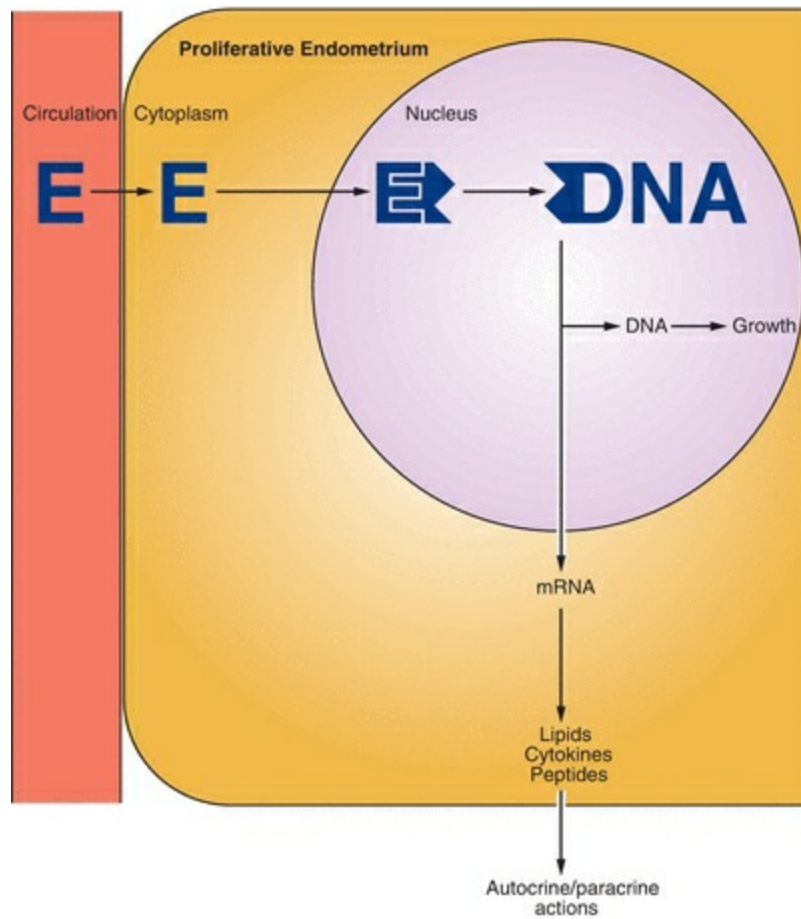
The presence of the cytokine family, involved in inflammation and immune responses, is not surprising in a tissue that undergoes cyclic degeneration. The interleukins stimulate the production of prostaglandins as well as other cytokines.<sup>76</sup> Colony-stimulating factor-1 is a cytokine that influences cellular proliferation and the presence of macrophages. Interferon- $\gamma$  is produced by activated T lymphocytes and inhibits endometrial epithelial proliferation. Leukemia-inhibiting factor (LIF) is expressed in response to a variety of other cytokines and growth factors. Like the interleukins, LIF is most abundant during the progesterone-dominated secretory phase and early decidua and likely plays an important role in embryo implantation.<sup>77,78</sup> TNF- $\alpha$  gene expression is present in the endometrium, and its activity is increased during the proliferative phase, decreased early in the secretory phase, and increased again in the midsecretory phase.<sup>79</sup> TNF- $\alpha$  exerts multiple influences on cellular growth (Table 3.1).

## TABLE 3.1 A Partial List of Endometrial Regulating Molecules

Lipids	Cytokines	Peptides
Prostaglandins	Interleukin-1 $\alpha$	Prolactin
Thromboxanes	Interleukin-1 $\beta$	Relaxin
Leukotrienes	Interleukin-6	Prorenin and renin
	Interferon- $\gamma$	Endorphin
	Colony-stimulating factor-1	Endothelin-1
	Tumor necrosis factor- $\alpha$	Corticotropin-releasing hormone
	Leukemia-inhibiting factor	Fibronectin
		Uteroglobin
		Lipocortin-1
		Parathyroid hormone-like protein
		Integrins
		Epidermal growth factor family
		EGF
		Heparin-binding EGF
		TGF- $\alpha$
		Insulin-like growth factor family
		IGF-1
		IGF-2
		IGFBPs 1–6
		Transforming growth factor- $\beta$ family
		Activins
		Inhibins
		Follistatin
		Platelet-derived growth factor
		Fibroblast growth factor
		Vascular endothelial growth factor
		Gonadotropin-releasing hormone (GnRH)

Growth factors are peptides that bind to specific cell membrane receptors and initiate intracellular signaling pathways. Because the growth factors are potent mitogens, it is also not surprising that the follicular phase of the cycle, associated with proliferative activity of the endometrium, is marked by dramatic alterations in growth factors. Estrogen stimulates gene expression for epidermal growth factor (EGF) (and its receptor) and IGF production. In turn, EGF elicits estrogen-like actions by interacting with the estrogen receptor mechanism.<sup>80</sup> EGF, a potent mitogen, is present in

endometrial stromal and epithelial cells during the follicular phase of the cycle and in the stromal cells during the luteal phase.<sup>81</sup> TGF- $\alpha$  and EGF work through the same receptor and are important mediators of estrogen-induced growth of the endometrium. TGF- $\alpha$  levels peak at midcycle, in contrast to EGF levels, which are relatively stable and noncyclic.<sup>82,83,84</sup> Platelet-derived growth factor is a potent mitogen localized to stromal cells (**Figure 3.12**).



**FIGURE 3.12**

The IGFs promote cellular mitosis and differentiation. They are expressed in a pattern controlled by estrogen and progesterone. IGF-1 is predominant in the proliferative and early secretory endometrium, and IGF-2 appears in the mid to late secretory phase and persists in early pregnancy decidua.<sup>85</sup> Endometrial IGF-1 expression is correlated with the circulating estrogen levels during the menstrual cycle.<sup>86</sup> This suggests that IGF-1 synthesis is regulated by estrogen and mediates estrogen-induced growth of the endometrium and IGF-2 is involved in differentiation in response to progesterone. Evidence in the monkey indicates that IGF-1 is the primary regulator of myometrial

growth in response to estrogen as well as to estrogen plus progesterone.<sup>87</sup>

As elsewhere in the body, the myometrial IGF activity is modulated by the IGF-binding proteins, which respond to the sex steroids in a differential manner; IGFBP-2 parallels IGF-1 response, whereas IGFBP-3 is decreased in the muscle but increased in vascular endothelium by estrogen.<sup>88</sup> IGFBP-4 and IGFBP-5 respond to estrogen but are unaffected by the addition of progesterone. IGFBP-1, as discussed later, is a major product of decidualized endometrium.

Gonadotropin-releasing hormone (GnRH) is present in the endometrium and in increased amounts in secretory endometrium and decidua.<sup>89</sup> In human decidual cells, GnRH increases the expression of MMPs, suggesting a role for GnRH in the regulation of the enzymes involved in implantation.<sup>90</sup> Like all of these molecules, GnRH is involved in signaling pathways associated with cell proliferation and breakdown, interacting with adhesion factors such as integrins, enzymes, and angiogenic substances.<sup>91</sup>

Human myometrial smooth muscle and endometrial stromal cells express mRNA for parathyroid hormone-like protein, the function of which is unknown.<sup>92</sup> TGF- $\beta$  stimulates the production of the parathyroid hormone-like protein. TGF- $\beta$  production is greatest in the secretory phase and may inhibit cellular proliferation by increasing IGFBP-3 synthesis.

Prostaglandins are produced by both epithelial and stromal cells, and the prostaglandin content in the endometrium reaches a peak level in the late secretory endometrium. The predominant prostaglandin produced by the endometrium is prostaglandin F<sub>2 $\alpha$</sub> , a potent stimulus for myometrial contractions.<sup>93</sup> Endometrial prostaglandin production decreases dramatically after implantation, suggesting the presence of an active mechanism for suppression.<sup>94</sup> The production of prostaglandins requires estrogen support, but the increased production by secretory endometrium indicates progesterone enhancement, and acute withdrawal of progesterone promotes a further increase.<sup>93</sup> Endometrial stromal cells produce prostacyclin and thromboxane in response to estrogen, a response that can be blocked by progestins.<sup>95</sup> The myometrium principally produces prostacyclin, utilizing precursors derived from the endometrium. However, receptors for all members of the prostaglandin family are present on human myometrial cells, and contraction of the myometrium is a major consequence of prostaglandin F<sub>2 $\alpha$</sub> .<sup>96</sup>

Thromboxane is synthesized by uterine tissues. Gene expression for the thromboxane synthase and for the thromboxane receptor can be identified in endometrial glands, stromal cells, myometrial smooth muscle, and uterine blood vessels.<sup>97</sup>

Thromboxane A<sub>2</sub> is a potent vasoconstrictor and stimulator of smooth muscle cells. Because of its rapid metabolism, it is limited to autocrine and paracrine activity.

Women with excessive menstrual bleeding have alterations in the normal rates of prostaglandin production. For this reason, effective reductions in menstrual blood loss can be achieved with treatment utilizing one of the nonsteroidal anti-inflammatory agents that inhibit prostaglandin synthesis. These agents are also effective treatment for prostaglandin-mediated dysmenorrhea.

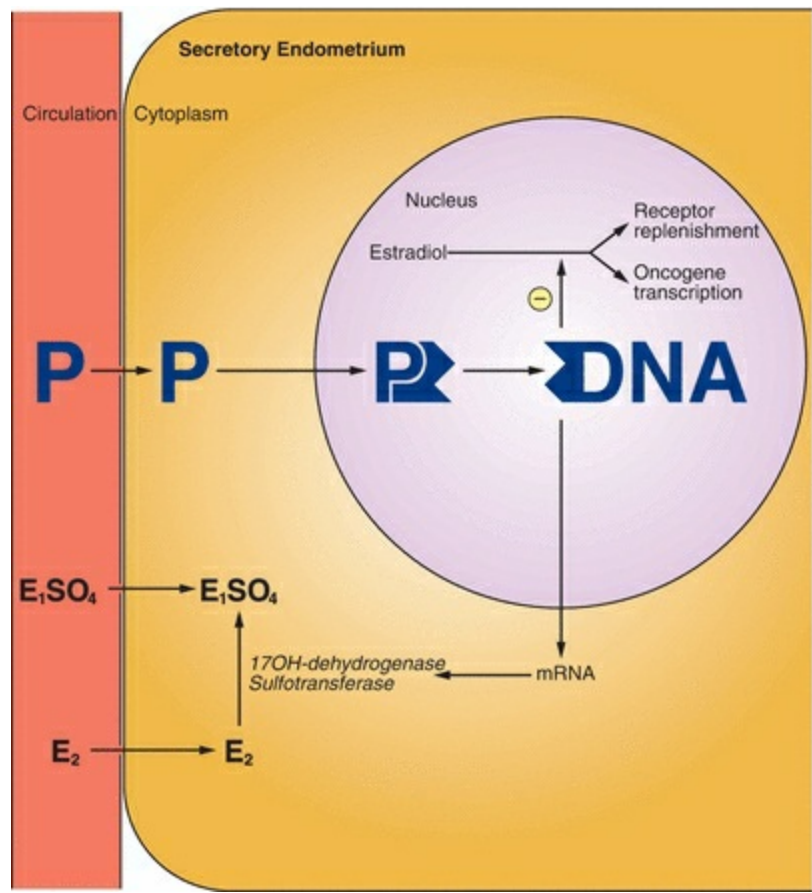
Fibronectin and laminin are extracellular matrix substances that are secreted by stromal cells of the endometrium in response to progesterone.<sup>98</sup> These proteins are important adhesion molecules during implantation. Integrins are a family of glycoproteins that function as receptors for proteins such as collagen, fibronectin, and laminin. The integrins are highly expressed in the endometrium and are important for cell-to-cell and cell-to-matrix interactions.<sup>99</sup> The expression of integrins is regulated by cytokines and growth factors, not estrogen and progesterone.<sup>100</sup>

Endothelins are potent vasoconstrictors produced in the vascular endothelial cells. The vasoconstrictor activity of endothelin-1, present in the endometrium, is balanced by the fact that it promotes the synthesis of the vasodilators nitric oxide and prostacyclin. Endothelin-1 is synthesized in endometrial stromal cells and the glandular epithelium, stimulated by both TGF- $\beta$  and interleukin-1 $\beta$ .<sup>101</sup> Endothelin-1 is at least one agent responsible for the vasoconstriction that shuts off menstrual bleeding. It is also a potent stimulator of myometrial contractions and can contribute to dysmenorrhea. Finally, endothelin-1 is a mitogen and can promote the healing and re-epithelialization of the endometrium. Human decidual cells also synthesize and secrete endothelin-1, from where it may be transported into the amniotic fluid.<sup>102</sup>

Angiogenesis, the formation of new blood vessels, is an essential process in tissue growth and development. Angiogenesis is necessary for tumor growth, and, in normal tissues, it is usually kept in check by regulating factors. The female reproductive tissues (specifically ovarian follicles, the trophoblast, and the endometrium), however, must experience periodic and rapid growth and regression (**Figure 3.13**). In these tissues, angiogenesis is part of normal events. The endometrium is a major source for angiogenic factors during the menstrual cycle and during pregnancy.<sup>103</sup> The sex steroids estrogen and progesterone are the primary regulators of uterine angiogenesis in all mammalian species.<sup>104,105</sup> VEGFs, a collection of specific mitogens for endothelial cells, are abundantly expressed in human endometrium, reaching a peak that correlates with the maximal angiogenesis reached during the secretory phase.<sup>106,107</sup> The VEGF family contains six growth factors and utilizes three different receptors. During the proliferative phase, estrogen stimulates VEGF synthesis. VEGF expression is also



stimulated by hypoxia, specifically the hypoxia associated with endometrial breakdown, and the new blood vessel growth and the re-epithelialization of the endometrium in the new proliferative phase are dependent on these growth factors in response to estrogen.<sup>108,109</sup>



**FIGURE 3.13**

Angiogenesis is also influenced by many other growth factors and other substances such as fibronectin and prostaglandins. The fibroblast growth factor family, in particular, is highly mitogenic for endothelial cells and endometrial stromal cells. Angiopoietins sustain the endometrium by preventing apoptosis and stabilizing blood vessels. The endometrium also produces inhibitory proteins, and the final growth of blood vessels reflects the balance between the inhibitory and stimulatory factors.

In all types of endometrial and myometrial cells, estrogen receptor expression reaches a maximum in the late proliferative phase.<sup>110,111</sup> The concentration is greatest in the glandular epithelium. During the early secretory phase, estrogen receptor expression declines, followed by an increase in the mid and late secretory phases. These changes reflect the cyclic changes in estradiol (which increases estrogen receptor expression)

and progesterone (which decreases estrogen receptor expression). Although estrogen receptor-beta is present in human endometrium, it is less prominent than estrogen receptor-alpha and exhibits less change during the cycle, except when it becomes the predominant estrogen receptor in the endometrial vasculature in the late secretory period.<sup>112</sup> Estrogen stimulation of proliferation is largely, if not totally, mediated by estrogen receptor-alpha.

Progesterone receptor expression in endometrial glandular epithelium reaches a maximum in the late proliferative and early secretory phases (reflecting induction of progesterone receptor by estrogen) and then declines to nearly undetectable levels by the midpoint of the secretory phase. Stromal cells in the endometrium show only minor fluctuations in progesterone receptors during the menstrual cycle. Decidualizing stromal cells exhibit strong progesterone receptor expression, although progesterone receptors are absent from decidual epithelial cells. Smooth muscle cells of the uterus demonstrate strong progesterone receptor expression throughout the menstrual cycle. Many of the events in uterine growth and function are regulated by the interplay between estrogen and progesterone. In general, progesterone antagonizes estrogen stimulation of proliferation and metabolism. This antagonism can be explained by the effects of progestins on the estrogen receptor (a decrease in levels), on the enzymes that lead to excretion of estrogen from cells, and by progesterone suppression of estrogen-mediated transcription of oncogenes.

Androgen receptor is present in the endometrium at all stages of the menstrual cycle, in postmenopausal endometrium, and in the decidua of pregnancy.<sup>113</sup> Surprisingly, the androgen receptor concentration is constant throughout the cycle. Androgens suppress the proliferative effects of estrogen on the endometrium, and experimental evidence suggests that the suppressive effects on the endometrium induced by antiprogestational agents are mediated by the androgen receptor.<sup>114</sup>

The complexity of the endometrium can be appreciated by viewing the results of complementary DNA microarray studies. In one effort directed just to the endometrial breakdown associated with menstruation, 571 transcripts were identified that were involved in 131 biochemical pathways, including thyroid hormone synthesis and metabolism!<sup>115</sup> Gene expression studies are just beginning to profile the patterns associated with specific hormones and pharmacologic agents.<sup>116</sup>

# The Decidua

The decidua is the specialized endometrium of pregnancy. The term decidua is derived from the Latin verb *dêciduus*, meaning shedding or falling off, reflecting the periodic sloughing of the endometrium—just like a tree shedding its leaves only to grow new leaves in the next season, which are essential to maintain its life. Decidualization is the process of transformation of endometrial stromal cells into decidual cells, which is essential for supporting the implanting embryo and pregnancy. The biochemical dialogue between the fetoplacental unit and the mother must pass back and forth through the decidua. The classic view of the decidua conformed to its designation as a thin line in anatomic diagrams, a minor, inactive structural component. We now know that the decidua is a vigorous, active tissue.

Decidual cells are derived from the stromal cells of the endometrium, under the stimulation of progesterone. Increasing evidence from human and mouse studies supports a crucial role for transcriptional coregulators (coactivators and corepressors) such as repressor of estrogen receptor activity (REA) and steroid receptor coactivator-2 (Src-2) in this cellular transformation process.<sup>117,118</sup> Once the decidual process is initiated, differentiating stromal cells secrete a number of cytokines, growth factors, and morphogens involved in propagating this process. This transformation is regulated by members of the TGF- $\beta$  family, including activin A.<sup>119,120</sup> In addition, ghrelin acting via the growth hormone receptor is involved in this process.<sup>121</sup> Moreover, interleukins such as IL-1 $\beta$ <sup>122</sup> and leukemia inhibitory factor (LIF),<sup>123</sup> HOX genes, as well as members of the Notch signaling pathway play crucial roles in the transformation of stromal cells to decidualized cells.<sup>124,125,126,127,128</sup>

In the proliferative phase, endometrial stromal cells have a fibroblast-like appearance with little cytoplasm with elongated indented nuclei. Decidual cells appear during the secretory phase and continue to proliferate during early pregnancy, eventually lining the entire uterus including the implantation site. Decidual transformation is associated with rounding of the nucleus, increased number of nucleoli, and accumulation of glycogen and lipid droplets in the expanding cytoplasm. The decidual cell is characterized by the new expression of a host of substances, including prolactin, relaxin, renin, IGFs, and IGFbps. There is no evidence that these proteins are secreted into the circulation; therefore, they serve as autocrine and paracrine agents.<sup>129,130</sup>

Riddick was the first to detect prolactin in the decidualizing endometrium of the late luteal phase.<sup>131</sup> The amino acid sequence and the chemical and biologic properties of decidual prolactin are identical to those of pituitary prolactin. Decidual prolactin synthesis and release are controlled by the placenta, fetal membranes, and decidual factors. Dopamine, bromocriptine, and thyrotropin-releasing hormone (TRH), in

contrast to their action in the pituitary, have no effect on decidual synthesis and release of prolactin. A protein named decidual prolactin-releasing factor has been purified from the placenta, and an inhibiting protein, which blocks the stimulatory activity of the releasing factor, has been purified from decidua.<sup>130</sup> IGF-1, relaxin, and insulin all stimulate decidual prolactin synthesis and release, each through its own receptor. The same decidual cells produce both prolactin and relaxin. Prolactin exerts an overall inhibitory effect on the process of decidualization, perhaps an autocrine mechanism to limit the extent of decidualization.<sup>132</sup>

Lipocortin-1 is a calcium- and phospholipid-binding protein, present in the placenta and decidua, that inhibits phospholipase A<sub>2</sub> and responds to glucocorticoids. Lipocortin-1 inhibits decidual prolactin release but in a mechanism independent of phospholipase action and independent of glucocorticoids. The prostaglandin system is not involved in decidual prolactin production, and corticosteroids do not affect decidual prolactin release.<sup>133</sup>

In 1978, it was discovered that the source of amniotic fluid prolactin is not the pituitary but the decidua,<sup>134</sup> for which there is very strong supporting evidence. In vitro experiments indicate that the passage of prolactin across the fetal membranes is in the direction of the amniotic cavity. The amniotic fluid concentration correlates with the decidual content, not with maternal circulating levels. The proportion of prolactin-expressing cells in the decidua increases throughout pregnancy, and the level of expression correlates positively with decidual cell size.<sup>135,136</sup> Amniotic fluid prolactin reaches peak levels in the first half of gestation (about 4,000 ng/mL) when maternal plasma levels are approximately 50 ng/mL and fetal levels about 10 ng/mL. Maternal circulating prolactin reaches maximal levels near term. Finally, amniotic fluid prolactin is unaffected by bromocriptine treatment (which reduces both fetal and maternal circulating levels to baseline levels).

It is believed that decidual prolactin regulates amniotic fluid volume and electrolyte concentrations. Prolactin regulates water and ion transport in lower animals, and prolactin binds to amniotic membranes. Disorders in human pregnancy associated with abnormal amniotic fluid volumes may be explained by this mechanism, especially idiopathic polyhydramnios, which is associated with a decrease in the number of prolactin receptors in the membranes. Prolactin may be involved in the regulation of surfactant synthesis in the fetus, and prolactin may inhibit uterine muscle contractility. Prolactin suppresses the immune response and helps to prevent immunologic rejection of the conceptus. Prolactin in the uteroplacental unit has also been suggested to stimulate trophoblast growth and invasion, to promote angiogenesis, and to modulate uNK cell survival.<sup>137,138</sup>

Fibroblast growth factor, derived from decidua, stimulates blood vessel growth in

early pregnancy. Another factor, endothelial cell-stimulating angiogenesis factor (a nonprotein mitogen), is also derived from decidua and contributes to the vascularization of the decidua during the first trimester of pregnancy.<sup>139</sup> The expression of corticotropin-releasing hormone (CRH) has been demonstrated in human decidua, and many actions for decidual CRH are possible: activation of prostaglandins, stimulation of myometrial contractions, and a contribution to both maternal and fetal stress responses during pregnancy and labor.<sup>140</sup>

Prorenin (the inactive precursor of renin) is produced in decidua in response to IGF-1, insulin, endothelin, and relaxin.<sup>141,142,143</sup> A uterine role for renin has not been determined.

The IGFbps, IGFBP-1, IGFBP-2, IGFBP-3, and IGFBP-4, are produced by endometrial stromal cells.<sup>144</sup> Large amounts of IGFBP-1 are present in amniotic fluid. The IGFbps appear to be regulated by insulin, the IGFs, and relaxin.<sup>145</sup> Relaxin is related structurally to insulin and the IGFs, and it stimulates IGFBP-1 production in endometrial stromal cells.<sup>146</sup> IGFBP-1 is considered to be a marker for decidualization. Because it binds growth-promoting IGFs, the appearance of IGFBP-1 contributes to differentiation rather than proliferation of the endometrial stromal cells.

IGFBP-1 begins to appear in the midsecretory phase endometrium and reaches a level of major production in decidua late in the first trimester of pregnancy. IGFBP-1 levels peak around 16 weeks of gestation, preceding those of PRL. IGFBP-1, when first identified, was known as placental protein 12 and then as pregnancy-associated  $\alpha$ -globulin. By the second trimester of pregnancy, high levels of IGFBP-1 are present in the amniotic fluid and the circulation and then fall significantly during the third trimester. The decidual production of IGFBP-1 is correlated with the morphologic and histologic changes induced by progesterone and regulated by progesterone, relaxin, insulin, IGF-1, and IGF-2. In fact, IGFBP-1 is a mediator of progesterone-induced decidualization of endometrial stromal cells.<sup>147</sup> Binding of the IGFs to the IGFbps would limit further mitogenic activity in the endometrium in the secretory phase and during pregnancy. In addition, decidual IGFBP-1 may contribute to the limitation of trophoblast invasion.

The continuous stimulation of IGFBP-1 production by human endometrium can be maintained in women as long as they retain an intrauterine device that releases a progestin into the endometrial cavity.<sup>148</sup> In endometrial samples from these women, areas of endometrial atrophy correlate with intense staining for IGFBP-1. This makes a strong argument for the importance of IGFs for endometrial growth and the potential for prevention of endometrial growth by providing IGFBP-1.

The glycoprotein  $\alpha$ -subunit, common to follicle-stimulating hormone (FSH),

luteinizing hormone (LH), thyroid-stimulating hormone (TSH), and hCG, is secreted into the circulation by the pituitary and placenta. A specific role for the  $\alpha$ -subunit has not been apparent; however, gonadotropin receptors are present in the endometrium, and  $\alpha$ -subunit acts synergistically with progesterone to induce decidualization of endometrial cells in vitro.<sup>149</sup> In addition, the  $\alpha$ -subunit stimulates decidual prolactin secretion.<sup>150</sup>

The chorion laeve, villous trophoblast, and decidua are all sites of TGF- $\beta$  production.<sup>151</sup> TGF- $\beta$  can signal its own production; thus, TGF- $\beta$  can be a messenger from fetal tissues to decidua. TGF- $\beta$  is also believed to play a role in limiting trophoblastic invasion.<sup>152</sup> This may be accomplished by stimulating the production of PAI and the factor that causes tissue inhibition of metalloproteinases.<sup>153</sup>

# **SUMMARY: THE UTERINE ENDOMETRIUM**

---

**It is helpful to keep in mind a fundamental and relatively simple description: the endometrium is necessary for reproduction, and the synchronous, complex cycle of events is dependent on the endocrine guidance of estradiol and progesterone, modulated and mediated by the plethora of locally produced biochemical agents. Each and every signaling substance utilizes one of the pathways discussed in [Chapter 1](#) and makes a contribution to the dynamic sequence of morphologic and molecular events repeatedly dedicated to nourishing and supporting an early embryo.**

# ANATOMICAL ABNORMALITIES OF THE UTERUS

---

Congenital abnormalities of the müllerian ducts are relatively common, occurring in 7–10% of all women, and contributing to the problems of infertility, recurrent pregnancy loss, and poor pregnancy outcomes that occur in approximately 25% of women with uterine anomalies.<sup>154,155,156,157,158,159</sup> Major anomalies are about 3 times more common in women with recurrent miscarriages.<sup>160</sup> The problems encountered in pregnancy include preterm labor, breech presentations, intrauterine growth restriction, abnormal placentation, and other complications that lead to interventions and greater perinatal mortality. Cervical cerclage is often indicated for prevention of preterm labor due to these anomalies. In addition, these abnormalities can produce the symptoms of dysmenorrhea and dyspareunia and even amenorrhea. Endometriosis in young women, especially adolescents, should raise clinical suspicion of genital tract malformations. Because the embryologic origin of the ovaries is separate and distinct from that of the müllerian structures, patients with müllerian anomalies have normal ovaries and ovarian function. Conception and implantation are not prevented. Surgical correction is recommended for pain, endometriosis due to obstruction, and poor obstetrical outcomes (Table 3.2).

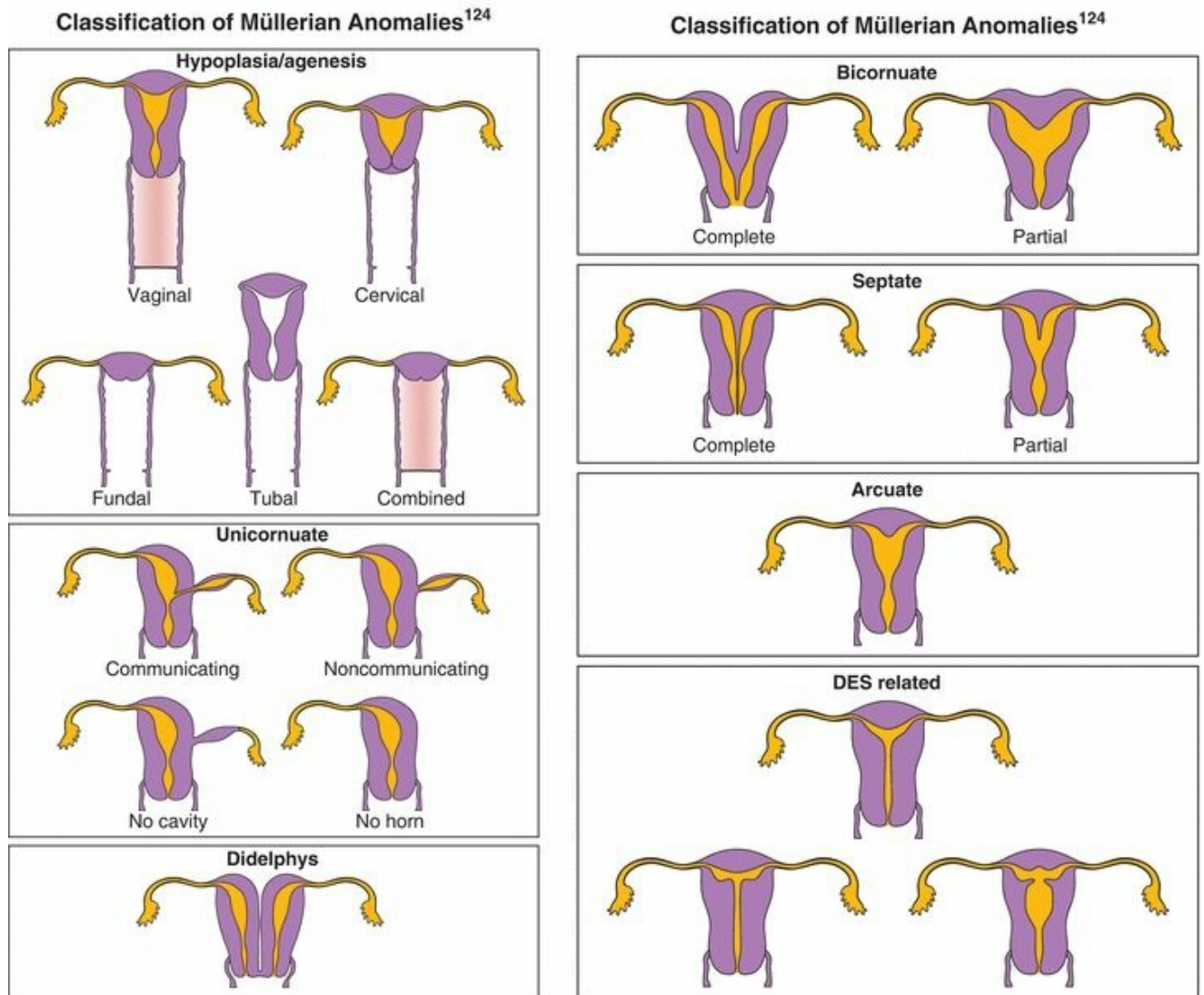
## TABLE 3.2 Incidence of Müllerian Defects



Fertile and infertile women	3–4% <sup>161</sup>
Women with recurrent miscarriages	5–10% <sup>158</sup>
Women with late miscarriages and preterm deliveries	>25% <sup>158</sup>

Anomalies can result from the failure of the müllerian ducts to fuse in the midline, to connect with the urogenital sinus, or to create the appropriate lumen in the upper vagina and uterus by resorption of the central vaginal cells and the septum between the fused müllerian ducts. Because fusion begins in the midline and extends cephalad, abnormal results are more common at the fundal portion of the uterus (bicornuate uterus). Formation of the uterine cavity begins at the lower pole and extends cephalad with dissolution of midline tissue; hence, incomplete resorption of tissue commonly yields persistence of the midline uterine wall (septum) intruding into the cavity. The molecular pathophysiology of these abnormalities has been insufficiently studied; however, the association with other somatic anomalies and occasional reports of familial transmission suggest genetic linkages.

Vaginal outflow tract obstruction can be minimal with a transverse septum or complete due to agenesis. A septum is the result of a defect in the connection of the fused müllerian ducts to the urogenital sinus or a failure of canalization of the vagina (**Figure 3.14**). The location of the septum varies, although it is usually in the upper or middle third of the vagina. Vaginal agenesis is the result of a complete failure in canalization; these patients present with amenorrhea or pain due to accumulated menstrual effluvium. Surgical correction is frequently necessary to relieve the relative constriction (and obstruction) of the vaginal canal. An absent vagina is usually accompanied by an absent uterus and tubes, the classic müllerian agenesis of the Mayer-Rokitansky-Kuster-Hauser syndrome (discussed in **Chapter 11**) (**Table 3.3**).



**FIGURE 3.14**

**TABLE 3.3 Distribution of Specific Anomalies**



Septate uterus	35%
----------------	-----

---

Bicornuate uterus	26%
-------------------	-----

---

Arcuate uterus	18%
----------------	-----

---

Unicornuate uterus	10%
--------------------	-----

---

Uterus didelphys	8%
------------------	----

---

Adapted from **Grimbizi GF, Camus M, Tarlatzis BC, Bontis JN, Devroey P**, Clinical implications of uterine malformations and hysteroscopic treatment results, Hum Reprod Update 7:161, 2001.

Uterine anomalies can be organized into the following categories.<sup>162</sup> Each of these can be associated with obstructions that present during adolescence with amenorrhea and cyclic pain.<sup>163</sup>

## Uterus Didelphys (Double Uterus)

Complete lack of fusion of the two müllerian ducts results in duplication of the corpus, cervix, and upper vagina. These patients usually have no difficulties with menstruation and coitus, except when there are problems with the two hemivaginas. Fifteen to twenty percent of women with didelphic uterus also have unilateral anomalies, such as an obstructed hemivagina (often with ipsilateral renal agenesis); the anomalies are on the right in 65% of cases.<sup>164</sup> Early diagnosis and excision of the obstructing vaginal septum will preserve fertility. Pregnancy is associated with an increased risk of miscarriage, malpresentations, and preterm labor, although many patients will have no reproductive difficulties.<sup>161,165,166</sup> Unification of the two endometrial cavities by metroplasty is generally not indicated and should only be considered in patients with repeated poor obstetrical outcomes. Unification of the two hemivaginas should be considered only in symptomatic cases and only when there is considerable fusion with no intervening bowel or bladder between the two.

# Unicornuate Uterus

An abnormality that is unilateral obviously is due to a failure of development in one müllerian duct (probably a failure of one duct to migrate to the proper location). The altered uterine configuration is associated with an increase in endometriosis and in obstetrical complications (early spontaneous miscarriage, ectopic pregnancy, abnormal presentations, intrauterine growth retardation, and preterm labor).<sup>165,167,168,169,170</sup> There may be a rudimentary horn present, and implantation in this horn is followed by a very high rate of pregnancy wastage or tubal pregnancies. A rudimentary horn can also be a cause of chronic pain, and surgical excision is worthwhile. However, most rudimentary horns are asymptomatic because they are noncommunicating, and the endometrium is not functional. Because of the potential for problems, prophylactic removal of the rudimentary horn is recommended when it is encountered during a surgical procedure. Patients with a unicornuate uterus have a particularly high incidence (40%) of urinary tract anomaly (usually of the kidney).<sup>171</sup> Surgical reconstructive procedures do not improve obstetrical outcomes; however, cervical cerclage may be beneficial when indicated.

# The Bicornuate Uterus

This anomaly results from partial rather than complete lack of fusion of the two müllerian ducts, producing a single cervix with a varying degree of separation in the two uterine horns. A bicornuate uterus has a fundal indentation that is  $\geq 1$  cm. This anomaly is relatively common, and pregnancy outcome has usually been reported to be near normal. Some, however, find a high rate of early miscarriage, preterm labor, and breech presentations.<sup>157,165</sup> Even with a history of repeated poor pregnancy outcomes that are thought to be related to the anomaly, surgical metroplasty is rarely considered. The cervical length should be assessed during pregnancy due to an association between bicornuate uterus and cervical insufficiency.

# The Septate Uterus

The septate uterus is the most common uterine anomaly, accounting for 35–90% of uterine malformations. Partial lack of resorption of the midline septum between the two müllerian ducts results in fibromuscular defects that range from a slight midline septum (the arcuate, heart-shaped cavity) to a significant midline division of the endometrial cavity. There is variation in the composition of the septum in terms of thickness, the relative amounts of fibrous and muscular tissue, and the degree of vascularization. A total failure in resorption can leave a longitudinal vaginal septum. This defect is not a cause of infertility, but once pregnant, the greater the septum, the greater the risk of recurrent spontaneous miscarriage, especially in the second trimester. The complete septate uterus is associated with a high risk of spontaneous miscarriage, preterm labor, intrauterine growth retardation, and breech presentation.<sup>157,172,173</sup> Even a small septum is associated with these poor obstetrical outcomes.<sup>174</sup> Outcomes are excellent with treatment by hysteroscopy.<sup>161,173,175,176,177,178,179</sup> Posttreatment miscarriage rates are approximately 10% in contrast to the 21–44% pretreatment rates with a septum. Longer septa appear to be associated with a higher risk of recurrent miscarriage, but this is controversial and many women with septa are asymptomatic and have good pregnancy outcomes. When the septum includes the cervix, it may appear as two cervixes. A cervical septum should be left in place so as not to promote cervical incompetence; the septum will dissipate in labor or can be lysed at that time. A longitudinal vaginal septum usually does not have to be excised (unless dyspareunia is a problem). Prophylactic surgery is considered appropriate for a septate uterus in older women when adverse pregnancy outcomes may lead to delays until the age of diminishing fertility or in women being treated with in vitro fertilization.

# Arcuate Uterus

**An arcuate uterus has a slight midline indentation with minimal, and often broad, fundal cavity indentation. Although it was previously believed to have clinical consequence, an arcuate uterus is now classified as a normal variant and is not associated with adverse impact on reproductive outcome.<sup>180</sup> A surgical procedure is not indicated for the arcuate uterus.**



## Very Rare Anomalies

Isolated agenesis of the cervix or the endometrium is incredibly rare. The absence of the cervix can lead to so much pain and obstruction that hysterectomy is the best solution. Attempts to preserve fertility by creating a fistulous communication between the uterus and vagina have achieved some success, but repeat surgery due to reappearance of obstruction is common.<sup>181,182</sup> In asymptomatic patients or those with a strong desire for pregnancy, consideration should be given to the preservation of structures for the possibility of pregnancy that can be achieved by means of one of the techniques of assisted reproduction ([Chapter 28](#)). With no normal outflow tract, retrograde menstruation is inevitable leading to endometriosis. In these women, complete endometrial suppression with an oral contraceptive or GnRH agonist/antagonist is appropriate until the time of conception.

# The Diethylstilbestrol-Associated Anomaly

Diethylstilbestrol (DES) is a nonsteroidal estrogen first synthesized in 1938. It was initially used for postpartum lactation suppression and treatment of postmenopausal symptoms, but its use later expanded to prevention of miscarriage, preterm birth, and other pregnancy problems. It is estimated that a total of 5 million women worldwide received DES to improve pregnancy outcome.

Abnormalities related to DES are becoming increasingly more rare since the U.S. Food and Drug Administration (FDA) advised against its use in pregnancy in 1971, following reports of vaginal clear cell adenocarcinoma in offspring of patients who used this drug. DES crosses the placenta, and exposure to DES during a critical period of organogenesis causes multiple uterine malformations, maldevelopment of the uterine muscle layers, lack of stratification of the vaginal epithelium, and resorption of vaginal glands leading to vaginal adenosis. Mothers who were treated in 1938–1971 with high doses of DES early in their pregnancies had children who developed a variety of anomalies, ranging from the hypoplastic T-shaped uterus to irregular cavities with adhesions.<sup>183</sup> Women with uterine abnormalities usually also have cervical defects. In these individuals, the chance of term pregnancy is decreased because of higher risks of ectopic pregnancy, spontaneous miscarriage, and premature labor.<sup>184</sup> An incompetent cervix is common. Poor outcome is correlated with an abnormal uterus on hysterosalpingography. No treatment is available beyond cervical cerclage.

# Accurate Diagnosis of Anomalies

In the past, full diagnosis required surgical intervention, first laparotomy and then, more recently, laparoscopy. Today, vaginal ultrasonography, especially three-dimensional ultrasound, sonohysterography, and magnetic resonance imaging are highly accurate, and surgical intervention is usually not necessary.<sup>185,186,187</sup> Hysterosalpingography alone can yield inaccurate results due to a failure to perfuse both uterine horns on either side of a midline division and due to the inability to clearly visualize the outer portion of the fundus. One cannot reliably distinguish bicornuate and septate uteri; both appear as two separate patent endometrial compartments. Decisions should not be based on hysterosalpingography alone. Congenital anomalies of the müllerian ducts are frequently accompanied by abnormalities in the urinary tract, such as a horseshoe or pelvic kidney. Renal agenesis can be present on the same side as a müllerian defect.

# LEIOMYOMAS (UTERINE FIBROIDS)

---

Uterine leiomyomas are benign neoplasms that arise from uterine smooth muscle and cause abnormal uterine bleeding and symptoms secondary to a large pelvic mass. It is hypothesized that leiomyomas originate from somatic mutations in myometrial cells, resulting in progressive loss of growth regulation.<sup>188,189</sup> The tumor grows as genetically abnormal clones of cells derived from a single progenitor cell (in which the original mutation took place). Studies indicate that leiomyomas are monoclonal.<sup>190</sup> Different rates of growth can reflect the different chromosomal abnormalities present in individual tumors. Multiple myomas within the same uterus are not clonally related; each myoma arises independently.

The presence of multiple myomas (which have a higher recurrence rate than single myomas) argues in favor of a genetic predisposition for myoma formation. There is about a 2.5-fold increased risk of developing myomas in the first-degree relatives of women with these tumors,<sup>191</sup> and monozygotic twins' concordance for uterine leiomyoma diagnosis is almost twice that of dizygotic twins.<sup>192</sup> Hereditary leiomyomatosis and renal cell carcinoma are autosomal dominant syndromes with both cutaneous and uterine leiomyomas. The risk of renal cell carcinoma and that of leiomyosarcoma is increased in this syndrome.<sup>193,194</sup> The gene involved is **fumarate hydratase**, coding for an enzyme involved in the Krebs cycle. A family history of cutaneous leiomyomas should trigger screening for this gene mutation. Renal cell cancer occurs in 10–16% of women with this syndrome. Moreover, two recent genome-wide association studies identified several single nucleotide polymorphisms that are significantly associated with uterine leiomyoma diagnosis.<sup>195,196</sup> Such studies will likely yield patterns identifying women at high risk for uterine leiomyomas and perhaps risk for recurrence following ablation treatments and for malignant progression to leiomyosarcoma. Thus far, chromosomal abnormalities have been described in about 40% of myomas.<sup>197</sup> Mutations in the Med12 gene have been described as a key driver of but do not explain all fibroids.<sup>198</sup>

It is not certain whether leiomyosarcomas arise independently or from leiomyomas. However, the incidence of leiomyosarcomas in patients with leiomyomas is very low (<1%).<sup>199</sup> Gene profiling has not discovered shared abnormalities or a common molecular pathway comparing myomas with leiomyosarcomas.<sup>200</sup>

If surgical specimens are serially sectioned, about 77% of women who come to hysterectomy will have myomas, many of which are occult.<sup>201</sup> By the age of menopause, ultrasound can identify myomas in about 80% of black American women and 70% of white American women.<sup>202</sup> Approximately 25% of women will have symptomatic

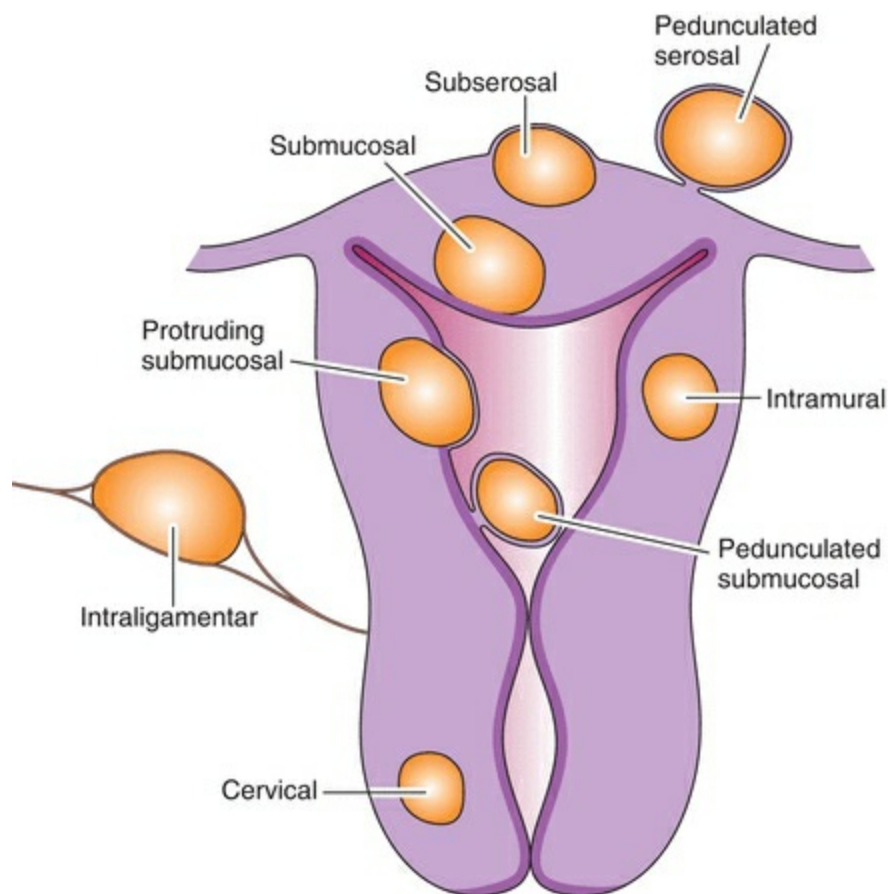
fibroids during their reproductive years. In the United States, about 40% of abdominal hysterectomies and 17% of vaginal hysterectomies are performed for leiomyomas.<sup>203</sup> The peak incidence for myomas requiring surgery occurs around age 45, approximately 8 cases per 1,000 women each year.<sup>204</sup> In the United States, approximately 10–15% of women require hysterectomy for myomas. For unknown reasons, uterine leiomyomas are 2–3 times more prevalent in black women compared with white, Hispanic, and Asian women and account for 75% of hysterectomies among black women.<sup>202,205,206</sup>

Myomas are present (diagnosed by ultrasonography) in about 30% of women and in about 1–2% of pregnancies.<sup>207,208</sup> The risk of myoma is decreased with increasing parity and with increasing age at last term birth.<sup>208,209</sup> Women with at least two full-term pregnancies have half the risk for myomas. Smoking decreases the risk (presumably by decreasing estrogen levels), and obesity increases the risk (presumably by increasing estrogen levels). Although a lower risk for myomas is associated with factors that decrease estrogen levels, including leanness, smoking, and exercise, the use of oral contraceptives is not associated with an increased risk of uterine myomas, although the Nurses' Health Study reported a slightly increased risk when oral contraceptives were first used in early teenage years.<sup>209,210,211</sup>

The hormone sensitivity of leiomyomas is further indicated by the following clinical observations. Leiomyomas develop during the reproductive (hormonally active) years and regress after menopause. Occasionally, leiomyomas grow during pregnancy, and the hypogonadal state induced by treatment with GnRH agonists often causes shrinkage of myomas.

The environment within the leiomyoma is hyperestrogenic. The estradiol concentration is increased, and leiomyomas contain more estrogen and progesterone receptors.<sup>212,213,214,215</sup> Aromatase gene and enzyme expression are present in significant levels in leiomyomas.<sup>216</sup> Indeed, leiomyoma tissue is hypersensitive to estrogen and appears to have lost a regulatory influence that limits estrogen response.<sup>217</sup> Endometrial hyperplasia can be observed at the margins of submucosal myomas.<sup>218</sup> In the myometrium and in leiomyomas, peak mitotic activity occurs during the luteal phase, and mitotic activity is increased by the administration of high doses of progestational agents.<sup>219,220</sup> These facts indicate that progesterone stimulates mitotic activity in leiomyomas. Similarly, clinicians have reported both regression and growth with progestational treatment (**Figure 3.15**). Nevertheless, clear evidence supports a growth-promoting role for progestins. The association with estrogen can be explained by the estrogen enhancement of progesterone receptor expression.<sup>221,222</sup> Treatment with mifepristone, the progesterone antagonist, or with asoprisnil or ulipristal, selective progesterone receptor agonist/antagonists, is associated with a reduction in leiomyoma

size.<sup>223,224</sup>



**FIGURE 3.15**

At least one pathway for the growth-promoting effect of progestins is the induction of BCL2 gene expression increasing the production of the Bcl-2 protein that inhibits apoptosis and promotes cell replication.<sup>225</sup> Bcl-2 protein expression is increased in leiomyoma cells and markedly increases in response to progesterone.<sup>226</sup> In contrast, normal myometrial cells do not respond to estradiol or progesterone with Bcl-2 protein expression, and there is no cyclic change throughout the menstrual cycle.

As in the normal uterus, the effects of estrogen and progestins on leiomyomas are mediated by growth factors.<sup>227</sup> EGF is overexpressed in myomas, EGF receptors are present in leiomyomas, and GnRH agonist treatment (and hypogonadism) decreases EGF concentration in myomas (but not in normal myometrium).<sup>228,229</sup> IGF-1 and IGF-2 and their receptors are abundant in myometrium and actively overexpressed in leiomyomas.<sup>230,231</sup> Leiomyomas express more IGF-2 and less IGFBP-3 than myometrium, a situation that would enhance growth factor availability and activity in the

tumor.<sup>232</sup> Leiomyoma cells express more parathyroid hormone–related protein (another growth factor) than normal myometrium.<sup>233</sup> Like the endometrium and myometrium, leiomyomas secrete prolactin, and prolactin functions in the uterus as a growth factor.<sup>234</sup> Even hematopoiesis is possible in a leiomyoma.<sup>235</sup>

Multiple angiogenic growth factors such as VEGF, basic FGF, and PDGF display altered expression in leiomyomas and are likely responsible for the vascular abnormalities seen in this disease.<sup>236,237</sup> These vascular abnormalities have been described by classical studies showing that fibroids have an abnormal vasculature and are generally much less vascular than the surrounding myometrium.<sup>238,239,240</sup> This decreased vasculature likely accounts for the severe hypoxia noted in fibroid tissue.<sup>241</sup> These vascular changes probably contribute to the heavy menstrual bleeding associated with submucosal myomas. Understanding this vascular dysregulation may help to delineate the pathophysiology of this important disorder and may lead to innovative targeted treatments.

Uterine growth and signaling molecules are highly expressed in leiomyomas.<sup>242</sup> As with all tumors, these pathways in leiomyomas may one day be targeted by gene therapy. For example, specific adenoviruses can deliver altered genes to myoma cells that can interfere with the gene expression required for tumor growth and cellular functions.

# Reproductive Function and Leiomyomas

Leiomyomas are an infrequent cause of infertility, either by mechanical obstruction or distortion (and interference with implantation).<sup>243,244</sup> When a mechanical obstruction of fallopian tubes, cervical canal, or endometrial cavity is present and no other cause of infertility or recurrent miscarriage can be identified, myomectomy is usually followed by a prompt achievement of pregnancy in a high percentage of patients (usually within the 1st year).<sup>244,245</sup> Small submucosal myomas are best treated by hysteroscopic resection. Preoperative visualization is important, and mapping of myomas by sonohysterography or magnetic resonance imaging (MRI) is superior to standard ultrasonography (which is relatively inaccurate).<sup>246</sup> It is difficult to distinguish between submucosal myomas and endometrial polyps with ultrasonography.<sup>247</sup> Very large myomas (>4–5 cm) and myomas that do not have greater than 50% protrusion into the cavity are not good candidates for hysteroscopic removal.

The 5-year recurrence rate after abdominal myomectomy for a single myoma is about 10%, and 25% with multiple myomas, with subsequent hysterectomy necessary in one-third of patients with recurrence.<sup>248</sup> In a series with long-term follow-up, the recurrence rate over 10 years after single myomectomy reached 27%.<sup>249</sup> Women who gave birth after myomectomy had a recurrence rate (over 10 years) of 16%, compared to a rate of 28% in those who did not give birth. In an Italian study of recurrence, the rate at 5 years reached 55% in those who did give birth after surgery and 42% in those with no childbirth.<sup>250</sup> These differences may reflect the diligence and sensitivity of the ultrasonographic assessments.

Myomectomy for infertility or recurrent miscarriage requires a deliberate and careful decision after all factors have been considered. Intracavitary myomas, however, usually require surgery. Submucosal myomas are associated with general cavity alterations in the expression of proteins involved with implantation, not just an effect confined to the endometrium over the myoma.<sup>251,252,253</sup> Subserous myomas do not typically affect fertility unless there is compression of the fallopian tubes. Intramural myomas that do not distort the endometrial cavity probably have less effect on implantation and the risk of miscarriage<sup>254</sup> than those that distort the cavity; however, they may still have an effect if the myoma is large or in close proximity to the endometrium.<sup>255,256</sup> Because of the rapid regrowth of myomas following cessation of GnRH agonist therapy, medical therapy for infertility is not recommended.

Most myomas do not grow during pregnancy.<sup>257</sup> When they do, most of the growth is in the first trimester, and most myomas regress in size after the pregnancy. The size of a myoma will not predict its course; large myomas will not necessarily grow more than



small ones. Most pregnancies, in the presence of myomas, will, therefore, be uncomplicated (although a higher incidence of cesarean section has been observed).<sup>207,258</sup> Nevertheless, the risks of malpresentations, preterm delivery, and spontaneous miscarriage are increased.<sup>259</sup> The so-called red degeneration of myomas is occasionally observed during late pregnancy, a condition that is due to central hemorrhagic infarction of the myoma. Pain is the hallmark of this condition, occasionally associated with rebound tenderness, mild fever, leukocytosis, nausea, and vomiting. Usually, pain is the only symptom and resolution follows rest and analgesic treatment.<sup>260</sup> Surgery should be a last resort. The larger the myoma, the greater the risk of premature labor.<sup>261</sup>

# Medical Therapy of Leiomyomas

The goals of medical therapy for leiomyomas are to **temporarily** reduce symptoms and to reduce myoma size, and the therapy of choice is treatment with a GnRH agonist.<sup>262</sup> Any treatment that lowers endogenous estrogen levels should be effective, and therefore, the use of aromatase inhibitors is another option.<sup>263</sup> Medical therapy is provided preoperatively to improve anemia and reduce surgical complexity and recovery times.<sup>264</sup> Prolonged medical regimens have traditionally been expensive and complicated; however, the introduction of oral GnRH antagonists opens the potential for long-term use in fibroids. Similarly, medical therapy from fibroids using selective progesterone receptor modulators (SPRMs) has become popular in Europe and Canada where they are available; currently, no SPRM is available for this indication in the United States. Currently, with few exceptions, surgical treatment is preferred for symptomatic uterine leiomyomas until these new medical therapies are available.

The short half-life of GnRH is due to rapid cleavage of the bonds between amino acids 5–6, 6–7, and 9–10. By altering amino acids at these positions, analogues of GnRH can be synthesized with different properties. Substitution of amino acids at the 6 position or replacement of the C-terminal glycine amide (inhibiting degradation) produces agonists. An initial agonistic action (the so-called flare effect) is associated with an increase in the circulating levels of FSH and LH. This response is greatest in the early follicular phase when GnRH and estradiol have combined to create a large reserve pool of gonadotropins. After 1–3 weeks, desensitization and down-regulation of the pituitary produce a hypogonadotropic, hypogonadal state. The initial response is due to desensitization, the uncoupling of the receptor from its effector system, whereas the sustained response is due to a loss of receptors by down-regulation and internalization. Furthermore, postreceptor mechanisms lead to secretion of biologically inactive gonadotropins, which, however, can still be detected by immunoassay.

The GnRH analogues cannot escape destruction if administered orally. Higher doses administered subcutaneously can achieve nearly equal effects as those observed with intravenous treatment; however, the smaller blood peaks are slower to develop and take longer to return to baseline. Other forms of administration include nasal spray, sustained-release implants, and intramuscular injections of biodegradable microspheres.

## Treatment with GnRH Agonists

Summarizing the experience with GnRH agonist treatment of leiomyomas, the mean uterine size decreases 30–64% after 3–6 months of treatment.<sup>262</sup> Maximal response is usually achieved by 3 months. Menorrhagia, anemia, pelvic pressure, and urinary

frequency all respond favorably to GnRH agonist treatment.<sup>265,266</sup> GnRHa treatment results in a reduction in uterine and fibroid blood supply as measured by Doppler ultrasound and microvascular density.<sup>267,268</sup> A decrease in operative blood loss can be achieved when the pretreatment uterus is as large as a 16-week pregnancy or larger. However, some studies find no benefit in terms of surgical blood loss or length of hospital stay, and surgical dissection may be more difficult because of softening of the myoma.

Why is there a variation in response? When one considers the many factors involved in myoma growth (progesterone, estrogen, growth factors, and receptors), it makes sense that not every myoma is the same. After cessation of GnRH agonist therapy, menses return in 4–10 weeks, and myoma and uterine size return to pretreatment levels in 3–4 months. The rapid regrowth is consistent with the fact that reduction in size is not due to a cytotoxic effect. The shrinkage is due to loss of water and extracellular matrix.

Preoperative GnRH agonist therapy offers several advantages for hysteroscopic removal of submucosal tumors. In addition to a decrease in myoma size, endometrial atrophy will improve visualization, and decreased vascularity will reduce blood loss.

**Leiomyomatosis peritonealis disseminata** is a condition in which multiple small nodules of benign smooth muscle are found throughout the abdominal cavity and occasionally in the pulmonary cavity. This condition appears to be sensitive to estrogen and progestins because it has been aggravated by postmenopausal estrogen treatment and regression has been achieved with GnRH agonist treatment.<sup>269</sup>

**Adenomyosis** is the ectopic presence of endometrial glands within the myometrium. This diagnosis can be made by magnetic resonance imaging, and successful treatment with a GnRH agonist has been reported.<sup>270,271</sup>

## Side Effects of GnRH Agonists

Hot flushes are experienced by more than 75% of patients, usually in 3–4 weeks after beginning treatment. Approximately 5–15% of patients will complain of headache, mood changes, vaginal dryness, joint and muscle stiffness, and depression. About 30% of patients will continue to have irregular (although light) vaginal bleeding. It is useful to measure the circulating estradiol level. If the level is greater than 30 pg/mL, suppression is inadequate. A small number (10%) of patients will experience a localized allergic reaction at the site of injection of depot forms of GnRH analogues. More serious reaction is rare, but immediate and delayed anaphylaxis can occur, requiring intense support and management.<sup>272</sup>

Bone loss occurs with GnRH therapy if used without add-back hormone therapy, but not in everyone, and it is reversible if the course does not exceed 1 year. A significant

vaginal hemorrhage 5–10 weeks after beginning treatment is encountered in about 2% of treated women, due to degeneration and necrosis of submucosal myomas.<sup>273</sup> A disadvantage of agonist treatment is a delay in diagnosis of a leiomyosarcoma. Keep in mind that almost all leiomyosarcomas present as the largest or only uterine mass. Close monitoring is necessary, and surgery has been the usual recommendation when either enlargement or no shrinkage of myomas occurs during GnRH agonist treatment.<sup>274</sup> The use of Doppler ultrasonography or magnetic resonance imaging offers greater accuracy of evaluation. However, the incidence of leiomyosarcoma, even in patients with “rapidly growing leiomyomas,” is very low (<0.5%) and almost unheard of in premenopausal women.<sup>199</sup> In premenopausal women, a conservative approach is warranted.

Escape of suppression can result in an unexpected pregnancy. No adverse effects of fetal exposure to GnRH agonists have been reported, even when exposure has persisted throughout the early weeks of pregnancy.<sup>275</sup>

## **GnRH Agonists and Steroid Add-Back**

Treatment with a GnRH agonist with steroid add-back has been deployed to permit long-term therapy without bone loss.<sup>262</sup> Two strategies have been employed: simultaneous agonist and steroid add-back treatment or a sequential regimen in which the agonist is used alone for 3 months, followed by the combination of the agonist and steroid add-back. This long-term treatment is attractive for women who are perimenopausal, perhaps avoiding surgery. In addition, long-term treatment would be useful for women with coagulopathies and in women with medical problems who need to postpone surgery.

Simultaneous treatment with agonist and medroxyprogesterone acetate (20 mg daily) or norethindrone (10 mg daily) effectively reduced hot flushing but was less effective (consistent with the major growth-promoting role of progestins in myomas) in reducing uterine volume.<sup>262,276</sup> A sequential program, adding a traditional postmenopausal hormone regimen (conjugated estrogens/medroxyprogesterone acetate or estradiol/norethindrone), effectively reduced uterine volume and maintained the reduced volume for 2 years (and avoided any loss in bone density).<sup>262</sup> A daily 2.5-mg dose of tibolone also prevents bone loss and inhibits vasomotor symptoms without reducing the therapeutic efficacy of GnRH agonist treatment.<sup>277</sup> The addition of raloxifene to GnRH agonist treatment appeared to produce a greater reduction in leiomyoma size,<sup>278</sup> but the effect was not sufficiently different to be of clinical significance. Raloxifene treatment by itself, even in a large dose, failed to reduce leiomyoma size in premenopausal women, although in postmenopausal women, raloxifene produced a 30–40% reduction

in size after 1 year.<sup>279,280</sup> Treatment with raloxifene, alendronate, or tibolone prevents the bone loss associated with agonist therapy, but only tibolone also prevents hot flushing.<sup>277,281,282,283</sup>

We recommend 1 month of GnRH agonist treatment followed by agonist treatment combined with a daily, continuous add-back of estrogen and progestin using one of the available postmenopausal daily regimens. In view of the sensitivity of leiomyoma tissue to progestational agents, it makes sense to keep the dose of progestin relatively low. Preoperative GnRH agonist treatment is not indicated in every patient with uterine leiomyomas. The best candidates for treatment are women with bleeding and anemia to allow time for a response to iron supplementation and when the surgeon's clinical judgment suggests that a reduction in size may influence the choice of technique (e.g., laparoscopic or vaginal hysterectomy instead of laparotomy).

## **Treatment with a GnRH Antagonist**

GnRH antagonist treatment can suppress pituitary-gonadal function without the initial stimulatory (flare) response observed with GnRH agonists. Initial results with depot cetrorelix preoperative treatment of uterine fibroids were similar to those with GnRH agonist treatment; however, the response was faster (a maximal reduction in size within 14 days), probably because there is no initial flare response.<sup>284,285</sup>

More recently, a placebo-controlled trial showed that treatment with the GnRH antagonist elagolix alone or in combination with add-back therapy results in significant reduction of heavy menstrual bleeding in premenopausal women with fibroids. Hot flushes were the most common side effect, but this was much lower when add-back therapy was given in combination with elagolix.<sup>286</sup> This regiment avoids the initial flare effect seen with the GnRH agonists, is administered orally, and may be potentially used for long-term therapy. GnRH antagonist's approval of this indication is anticipated; however, the dose will be a higher one than that currently approved for use in the treatment of endometriosis.

## **Treatment with Mifepristone**

Mifepristone, the progestin antagonist, effectively reduces the size of uterine leiomyomas and produces amenorrhea in most patients. The initial study was relatively short term (12 weeks), and fibroid shrinkage was observed with doses of 25 and 50 mg daily.<sup>223</sup> A lower dosage is effective without the high rate of hot flushing observed at higher doses. In a 6-month study, a dose of 5-mg mifepristone daily was associated with a 48% reduction in uterine volume, a decrease in pressure and pain, an increase in hemoglobin levels, and a nonsignificant increase in hot flushing.<sup>287</sup> A similar reduction

in uterine volume was observed in a 3-month study with the 5-mg dose, also with improvements in pain and bleeding.<sup>288</sup> However, long-term mifepristone treatment can result in endometrial hyperplasia, a consequence of the antiprogestin action of the drug. This endometrial effect makes mifepristone an unacceptable choice for ongoing treatment of leiomyomas until large clinical trials are performed to establish its safety. Short-term treatment prior to surgery is appropriate. Asoprisnil, a SPRM, has also successfully reduced uterine volume and bleeding.<sup>224</sup> Ulipristal acetate, another SPRM, has been increasingly used to treat women with fibroids associated with heavy menstrual bleeding or with other moderate or severe symptoms. Data from available trials showed that endometrial changes were present in almost 70% of patients during treatment, appeared to be benign and reversible.<sup>289</sup> However, SPRMs have not been approved yet in the United States for this indication due to concerns over liver toxicity in Europe and Canada where these drugs have been widely used in the treatment of fibroids.

## **Treatment with the Levonorgestrel-Releasing Intrauterine System**

When uterine enlargement because of leiomyomas is no greater than the size of a 12-week pregnancy, the insertion of a levonorgestrel-releasing intrauterine system is followed by a decrease in uterine size in many but not all patients and a dramatic reduction in menstrual blood loss, with 40% of patients achieving amenorrhea.<sup>290,291,292</sup> The contraceptive efficacy is not diminished, but expulsion rates are higher. This method of treatment is not recommended when distortion of the uterine cavity is evident on examination with ultrasonography. The beneficial effect of locally applied levonorgestrel is unexplained, contrasting with the studies that indicate growth promotion of myomas by progestins; it likely functions by endometrial suppression rather than a direct effect on the fibroids.

## **Treatment with Uterine Artery Embolization**

Uterine artery embolization effectively reduces bleeding, pain, and fibroid size.<sup>293,294,295,296</sup> In a procedure under local anesthesia that takes about 1 hour, a catheter is advanced from the femoral artery to the uterine arteries to allow direct injection of polyvinyl particles or gelatin microspheres that occlude the blood flow. Myomas undergo necrosis in response to the transient ischemia, but normal tissue generates fibrinolysis and survives. The procedure is not recommended for large fibroids. After 5 years, recurrence of symptoms is about 10–25%. Most patients experience pain, nausea, and low-grade fever with a very high white blood count for 1–2 days following the procedure. In addition, serious complications occur, including complication-related

hysterectomy, amenorrhea, premature menopause, septicemia from uterine infection, bowel obstruction, and pulmonary embolus. Several deaths have been reported, giving a rate comparable to that with hysterectomy. A significant number of patients with larger myomas acquire intra-abdominal adhesions after the procedure.<sup>297</sup> The general recommendation is that embolization should not be performed in women who desire to retain their fertility. However, a substantial number of completed pregnancies have been reported after the procedure<sup>298,299</sup>; nevertheless, the fertility rates and the complication rates after pregnancy is achieved are not known with certainty. A randomized comparison with myomectomy indicated a higher rate of infertility and miscarriages after embolization.<sup>300</sup>

## Treatment with Ultrasound

A magnetic resonance mapping system for heat can be used to visualize myomas and direct high-energy ultrasound to destroy myomas.<sup>301,302</sup> The temperature achieved produces instant necrosis within a limited volume of tissue, and, therefore, the method requires multiple treatments over several hours. Thermal injuries to skin and normal tissues are potential side effects. MR-guided focused ultrasound (MRg-FUS) is FDA approved to treat patients who desire fertility, given that it is not associated with increased risks of spontaneous abortion and placental disorders. Data on successful term pregnancies after MRg-FUS are limited but appear comparable to surgical options.<sup>303,304</sup>

Transient uterine ischemia can be produced by placing vaginal clamps in the vaginal fornices, guided by ultrasonography, to compress the uterine arteries against the cervix for about 6 hours.<sup>305</sup> Short-term studies have demonstrated efficacy comparable to embolization, and long-term follow-up data have been reassuring.<sup>304</sup>

# REFERENCES

1. **Graham H**, *Eternal Eve, The History of Gynaecology & Obstetrics*, Doubleday & Company, Inc., Garden City, 1951.
2. **Medvei VC**, *The History of Clinical Endocrinology*, The Parthenon Publishing Group, New York, 1993.
3. **Magner LN**, *A History of Medicine*, Marcel Dekker, Inc., New York, 1992.
4. **Jost A, Vigier B, Prepin J, Perchellet JP**, Studies on sex differentiation in mammals, *Recent Prog Horm Res* 29:1, 1973.
5. **Josso N, Belville C, di Clemente N, Picard JY**, AMH and AMH receptor defects in persistent Mullerian duct syndrome, *Hum Reprod Update* 11(4): 351, 2005.
6. **Sadler TW**, *Langman's Medical Embryology*, 7th ed., Williams & Wilkins, Baltimore, 1995, p. 296.
7. Seifer DB, Tal R, eds. *Anti-Mullerian Hormone: Biology, Role in Ovarian Function and Clinical Significance*, Nova Biomedical, Hauppauge, New York, 2016.
8. **Acién P**, Embryological observations on the female genital tract, *Hum Reprod* 7:437, 1992.
9. **Markee JE**, Menstruation in intraocular endometrial transplants in the rhesus monkey, *JAMA* 250:2167, 1946.
10. **Markee JE**, Morphological basis for menstrual bleeding: relation of regression to the initiation of bleeding, *Bull N Y Acad Med* 24:253, 1948.
11. **Noyes RW, Hertig AW, Rock J**, Dating the endometrial biopsy, *Fertil Steril* 1:3, 1950.
12. **Bartelmez GW**, The form and the function of the uterine blood vessels in the Rhesus monkey, *Carnegie Inst Contrib Embryol* 36:153, 1957.
13. **Bartelmez GW**, The phases of the menstrual cycle and their interpretation in terms of the pregnancy cycle, *Am J Obstet Gynecol* 74:931, 1957.
14. **Murray MJ, Meyer WR, Zaino RJ, Lessey BA, Novotny DB, Ireland I, Fritz MA**, A critical reanalysis of the accuracy, reproducibility, and clinical utility of histologic endometrial dating: a systematic study of the secretory phase in normally cycling, fertile women, *Fertil Steril* 81:1333, 2004.
15. **Christiaens GCML, Sixma JJ, Haspels AA**, Hemostasis in menstrual endometrium: a review, *Obstet Gynecol Surv* 37:281, 1982.
16. **Jabbour HN, Kelly RW, Fraser HM, Critchley HOD**, Endocrine regulation of menstruation, *Endocr Rev* 27:17, 2006.
17. **Taylor HS**, Endometrial cells derived from donor stem cells in bone marrow transplant recipients, *JAMA* 292:81, 2004.
18. **Chan RW, Schwab KE, Gargett CE**, Clonogenicity of human endometrial epithelial and stromal cells, *Biol Reprod* 70:1738, 2004.
19. **Gargett CE, Schwab KE, Deane JA**, Endometrial stem/progenitor cells: the first ten years, *Hum Reprod Update* 22(2):137, 2016.
20. **Ludwig H, Spornitz UM**, Microarchitecture of the human endometrium by scanning electron microscopy: menstrual desquamation and remodeling, In: Bulletti C, Gurpide E, eds. *The Primate Endometrium*, The New York Academy of Sciences, New York, 1991, p. 28.
21. **Bergeron C, Ferenczy A, Shyamala G**, Distribution of estrogen receptors in various cell types of normal, hyperplastic, and neoplastic human endometrial tissues, *Lab Invest* 58:338, 1988.
22. **Bromer JG, Aldad TS, Taylor HS**, Defining the proliferative phase endometrial defect, *Fertil Steril* 91(3):698, 2009.
23. **Tabibzadeh SS**, Proliferative activity of lymphoid cells in human endometrium throughout the menstrual cycle, *J Clin Endocrinol Metab* 70:437, 1990.
24. **Tsai M-J, Clark JH, Schrader WT, O'Malley BW**, Mechanisms of action of hormones that act as transcription-regulatory factors, In: Wilson J, Foster D, Kronenberg H, Larsen P, eds. *Williams Textbook of Endocrinology*, W.B. Saunders Company, Philadelphia, 1998, pp. 55–94
25. **Haluska GJ, West NB, Novy MJ, Brenner RM**, Uterine estrogen receptors are increased by RU486 in late pregnant rhesus macaques but not after spontaneous labor, *J Clin Endocrinol Metab* 70(1):181, 1990.



26. **Mote PA, Balleine RL, McGowan EM, Clarke CL**, Colocalization of progesterone receptors A and B by dual immunofluorescent histochemistry in human endometrium during the menstrual cycle, *J Clin Endocrinol Metab* 84(8):2963, 1999.
27. **Mote PA, Balleine RL, McGowan EM, Clarke CL**, Heterogeneity of progesterone receptors A and B expression in human endometrial glands and stroma, *Hum Reprod* 15(Suppl 3):48, 2000.
28. **Spitz IM, Croxatto HB, Lähteenmäki P, Heikinheimo O, Bardin CW**, Effect of mifepristone on inhibition of ovulation and induction of luteolysis, *Hum Reprod* 9(Suppl 1):69, 1994.
29. **Lakha F, Ho PC, Van der Spuy ZM, Dada K, Elton R, Glasier AF, Critchley HO, Williams AR, Baird DT**, A novel estrogen-free oral contraceptive pill for women: multicentre, double-blind, randomized controlled trial of mifepristone and progestogen-only pill (levonorgestrel), *Hum Reprod* 22(9):2428, 2007.
30. **Chwalisz K**, The use of progesterone antagonists for cervical ripening and as an adjunct to labour and delivery, *Hum Reprod* 9(Suppl 1):131, 1994.
31. **Shaw KA, Topp NJ, Shaw JG, Blumenthal PD**, Mifepristone-misoprostol dosing interval and effect on induction abortion times: a systematic review, *Obstet Gynecol* 121(6):1335, 2013.
32. **Lydon JP, DeMayo FJ, Funk CR, Mani SK, Hughes AR, Montgomery CA Jr, Shyamala G, Conneely OM, O'Malley BW**, Mice lacking progesterone receptor exhibit pleiotropic reproductive abnormalities, *Genes Dev* 9(18):2266, 1995.
33. **Mulac-Jericevic B, Lydon JP, DeMayo FJ, Conneely OM**, Defective mammary gland morphogenesis in mice lacking the progesterone receptor B isoform, *Proc Natl Acad Sci U S A* 100(17):9744, 2003.
34. **Mulac-Jericevic B, Mullinax RA, DeMayo FJ, Lydon JP, Conneely OM**, Subgroup of reproductive functions of progesterone mediated by progesterone receptor-B isoform, *Science* 289(5485):1751, 2000.
35. **Gurpide E, Gusberg S, Tseng L**, Estradiol binding and metabolism in human endometrial hyperplasia and adenocarcinoma, *J Steroid Biochem* 7:891, 1976.
36. **Falany JL, Falany CN**, Regulation of estrogen sulfotransferase in human endometrial adenocarcinoma cells by progesterone, *Endocrinology* 137:1395, 1996.
37. **Kirkland JL, Murthy L, Stancel GM**, Progesterone inhibits the estrogen-induced expression of c-fos messenger ribonucleic acid in the uterus, *Endocrinology* 130:3223, 1992.
38. **Lima DA, Zhang J, Dunk C, Lye SJ, Croy BA**, Leukocyte driven-decidual angiogenesis in early pregnancy, *Cell Mol Immunol* 11:522, 2014.
39. **King A**, Uterine leukocytes and decidualization, *Hum Reprod Update* 6:28, 2000.
40. **Carson DD, Lagow E, Thathiah A, Al-Shami R, Farach-Carson MC, Vernon M, Yuan L, Fritz MA, Lessey B**, Changes in gene expression during the early to mid-luteal (receptive phase) transition in human endometrium detected by high-density microarray screening, *Mol Hum Reprod* 8:871, 2002.
41. **Dey SK, Lim H, Das SK, Reese J, Paria BC, Daikoku T, Wang H**, Molecular cues to implantation, *Endocr Rev* 25:341, 2004.
42. **Talbi S, Hamilton AE, Vo KC, Tulac S, Overgaard MT, Dosiou C, Le Shay N, Nezhat CN, Kempson R, Lessey BA, Nayak NR, Giudice LC**, Molecular phenotyping of human endometrium distinguishes menstrual cycle phases and underlying biological processes in normo-ovulatory women, *Endocrinology* 147:1097, 2006.
43. **Garrido-Gómez T, Ruiz-Alonso M, Blesa D, Diaz-Gimeno P, Vilella F, Simón C**, Profiling the gene signature of endometrial receptivity: clinical results, *Fertil Steril* 99(4):1078, 2013.
44. **Koot YE, van Hooff SR, Boomsma CM, van Leenen D, Groot Koerkamp MJ, Goddijn M, Eijkemans MJ, Fauser BC, Holstege FC, Macklon NS**, An endometrial gene expression signature accurately predicts recurrent implantation failure after IVF, *Sci Rep* 6:19411, 2016. doi:10.1038/srep19411.
45. **Giudice LC**, Application of functional genomics to primate endometrium: insights into biological processes, *Reprod Biol Endocrinol* 4(Suppl 1):S4, 2006.
46. **Ferenczy A, Bergeron C**, Histology of the human endometrium: from birth to senescence, In: Bulletti C, Gurpide E, eds. *The Primate Endometrium*, The New York Academy of Sciences, New York, 1991, p. 6.
47. **Du H, Taylor HS**, Contribution of bone marrow-derived stem cells to endometrium and endometriosis, *Stem Cells* 25:2082, 2007.

48. **Morelli SS, Rameshwar P, Goldsmith LT**, Experimental evidence for bone marrow as a source of nonhematopoietic endometrial stromal and epithelial compartment cells in a murine model, *Biol Reprod* 89:7, 2013.
49. **Tal R, Liu Y, Pluchino N, Shaikh S, Mamillapalli R, Taylor HS**, A murine 5-fluorouracil-based submyeloablation model for the study of bone marrow-derived cell trafficking in reproduction, *Endocrinology* 157(10):3749, 2016.
50. **Tal R, Shaikh S, Liu Y, Pluchino N, Alderman M III, Mamillapalli R, Taylor HS**, Bone marrow-derived progenitors become decidual cells and are essential for implantation and pregnancy maintenance. Society for Reproductive Investigation (SRI) 65th Annual Scientific Meeting, San Diego, CA, 2018.
51. **Lockwood CJ, Schatz F**, A biological model for the regulation of peri-implantational hemostasis and menstruation, *J Soc Gynecol Investig* 3:159, 1996.
52. **Krikun G, Lockwood GJ**, Steroid hormones, endometrial gene regulation and the Sp1 family of proteins, *J Soc Gynecol Investig* 9:329, 2002.
53. **Lockwood CJ, Krikun G, Rahman M, Caze R, Buchwalder L, Schatz F**, The role of decidualization in regulating endometrial hemostasis during the menstrual cycle, gestation, and in pathological states, *Semin Thromb Hemost* 33:111, 2007.
54. **Tabibzadeh S**, The signals and molecular pathways involved in human menstruation, a unique process of tissue destruction and remodelling, *Mol Hum Reprod* 2:77, 1996.
55. **Tabibzadeh S, Babaknia A, Kong QF, Zupi E, Marconi D, Romanini C, Satyaswaroop PG**, Menstruation is associated with disordered expression of Desmoplakin I/II, cadherin/catenins and conversion of F to G actin in endometrial epithelium, *Hum Reprod* 10:776, 1995.
56. **Fata J, Ho ATV, Leco KJ, Moorehead RA, Khoka R**, Cellular turnover and extracellular matrix remodelling in female reproductive tissues: functions of metalloproteinases and their inhibitors, *Cell Mol Life Sci* 57:77, 2000.
57. **Zhang J, Salamonsen LA**, In vivo evidence for active matrix metalloproteinases in human endometrium supports their role in tissue breakdown at menstruation, *J Clin Endocrinol Metab* 87:2346, 2002.
58. **Rodgers WH, Matrisian LM, Giudice LC, Dsupin B, Cannon P, Svitek C, Gorstein F, Osteen KG**, Patterns of matrix metalloproteinase expression in cycling endometrium imply differential functions and regulation by steroid hormones, *J Clin Invest* 94:946, 1994.
59. **Irwin JC, Kirk D, Gwatkin RBL, Navre M, Cannon P, Giudice LC**, Human endometrial matrix metalloproteinase-2, a putative menstrual proteinase. Hormonal regulation in cultured stromal cells and messenger RNA expression during the menstrual cycle, *J Clin Invest* 97:438, 1996.
60. **Schatz F, Krikun G, Runic R, Wang EY, Hauskenecht V, Lockwood CJ**, Implications of decidualization-associated protease expression in implantation and menstruation, *Semin Reprod Endocrinol* 17:3, 1999.
61. **Critchley HOD, Kelly RW, Baird DT, Brenner RM**, Regulation of human endometrial function: mechanisms relevant to uterine bleeding, *Reprod Biol Endocrinol* 4(Suppl 1):S5, 2006.
62. **Bruner KL, Rodgers WH, Gold LI, Korc M, Hargrove JT, Matrisian LM, Osteen KG**, Transforming growth factor beta mediates the progesterone suppression of an epithelial metalloproteinase by adjacent stroma in the human endometrium, *Proc Natl Acad Sci U S A* 92:7362, 1995.
63. **Zhang J, Salamonsen LA**, Tissue inhibitor of metalloproteinases (TIMP)-1, -2, and -3 in human endometrium during the menstrual cycle, *Mol Hum Reprod* 3:735, 1999.
64. **Kothapalli R, Buyuksal I, Wu S-Q, Chegini N, Tabibzadeh S**, Detection of eba1, a novel human gene of the transforming growth factor  $\beta$  superfamily, *J Clin Invest* 99:2342, 1997.
65. **Nayak NR, Critchley HOD, Slayden OD, Menrad A, Chwalisz K, Baird DT, Brenner RM**, Progesterone withdrawal up-regulates vascular endothelial growth factor receptor type 2 in the superficial zone of the human and macaque endometrium: potential relevance to menstruation, *J Clin Endocrinol Metab* 85:3442, 2000.
66. **Helftenbein G, Misseyanni A, Hagen G, Peter W, Slater EP, Wiehle RD, Suske G, Beato M**, Expression of the uteroglobin promoter in epithelial cell lines from endometrium, In: Bulletti C, Gurrpide E, eds. *The Primate Endometrium*, The New York Academy of Sciences, New York, 1991, p. 69.

67. **Makrigiannakis A, Margioris A, Markogiannakis E, Stournaras C, Gravanis A**, Steroid hormones regulate the release of immunoreactive  $\beta$ -endorphin from the Ishikawa human endometrial cell line, *J Clin Endocrinol Metab* 75:584, 1992.
68. **Lockwood C, Krikun G, Papp C, Toth-Pal E, Markiewicz L, Wang EY, Kerenyi T, Zhou X, Hausknecht V, Papp Z**, The role of progesteronally regulated stromal cell tissue factor and type-1 plasminogen activator inhibitor (PAI-1) in endometrial hemostasis and menstruation, *Ann N Y Acad Sci* 734:57, 1994.
69. **Schatz F, Aigner S, Papp C, Toth-Pal E, Hausknecht V, Lockwood CJ**, Plasminogen activator activity during decidualization of human endometrial stromal cells is regulated by plasminogen activator inhibitor 1, *J Clin Endocrinol Metab* 80:1504, 1995.
70. **Kelly RW, King AE, Critchley HOD**, Inflammatory mediators and endometrial function—focus on the perivascular cell, *J Reprod Immunol* 57:81, 2002.
71. **Wilborn WH, Flowers CE Jr**, Cellular mechanisms for endometrial conservation during menstrual bleeding, *Semin Reprod Endocrinol* 2:307, 1984.
72. **Treloar AE, Boynton RE, Borghild GB, Brown BW**, Variation of the human menstrual cycle through reproductive life, *Int J Fertil* 12:77, 1967.
73. **Belsey EM, Pinol APY; Task Force on Long-Acting Systemic Agents for Fertility Regulation**, Menstrual bleeding patterns in untreated women, *Contraception* 55:57, 1997.
74. **Rock J, Garcia CR, Menkin M**, A theory of menstruation, *Ann N Y Acad Sci* 75:830, 1959.
75. **Tazuke SI, Giudice LC**, Growth factors and cytokines in endometrium, embryonic development, and maternal:embryonic interactions, *Semin Reprod Endocrinol* 14:231, 1996.
76. **Tabibzadeh SS, Kaffka KL, Satyaswarop PG, Kilian PL**, IL-1 regulation of human endometrial function: presence of IL-1 receptor correlates with IL-1 stimulated PGE<sub>2</sub> production, *J Clin Endocrinol Metab* 70:1000, 1990.
77. **Arici A, Engin O, Attar E, Olive DL**, Modulation of leukemia inhibitory factor gene expression and protein biosynthesis in human endometrium, *J Clin Endocrinol Metab* 80:1908, 1995.
78. **Cullinan EB, Abbondanzo SJ, Anderson PS, Pollard JW, Lessey BA, Stewart CL**, Leukemia inhibitory factor (LIF) and LIF receptor expression in human endometrium suggests a potential autocrine/paracrine function in regulating embryo implantation, *Proc Natl Acad Sci U S A* 93:3115, 1996.
79. **Hunt JS, Chen H-L, Hu X-L, Tabibzadeh S**, Tumor necrosis factor- $\alpha$  messenger ribonucleic acid and protein in human endometrium, *Biol Reprod* 47:141, 1992.
80. **Ignar-Trowbridge DM, Nelson KG, Bidwell MC, Curtis SW, Washburn TF, McLachlan JA, Korach KS**, Coupling of dual signaling pathways: epidermal growth factor action involves the estrogen receptor, *Proc Natl Acad Sci U S A* 89:4658, 1992.
81. **Hofmann GE, Scott RT Jr, Bergh PA, Deligdisch L**, Immunohistochemical localization of epidermal growth factor in human endometrium, decidua, and placenta, *J Clin Endocrinol Metab* 73:882, 1991.
82. **Troche V, O'Connor DM, Schaudies RP**, Measurement of human epidermal growth factor receptor in the endometrium during the menstrual cycle, *Am J Obstet Gynecol* 165:1499, 1991.
83. **Prentice A, Thomas EJ, Weddell A, McGill A, Randall BJ, Horne CH**, Epidermal growth factor receptor expression in normal endometrium and endometriosis: an immunohistochemical study, *Br J Obstet Gynaecol* 99:395, 1992.
84. **Horowitz GM, Scott RT Jr, Drews MR, Navot D, Hoffman G**, Immunohistochemical localization of transforming growth factor- $\alpha$  in human endometrium, decidua, and trophoblast, *J Clin Endocrinol Metab* 76:786, 1993.
85. **Giudice LC, Dsupin BA, Jin IH, Vu TH, Hoffman AR**, Differential expression of messenger ribonucleic acids encoding insulin-like growth factors and their receptors in human uterine endometrium and decidua, *J Clin Endocrinol Metab* 76:1115, 1993.
86. **Zhou J, Dsupin BA, Giudice LC, Bondy CA**, Insulin-like growth factor system gene expression in human endometrium during the menstrual cycle, *J Clin Endocrinol Metab* 79:1723, 1994.
87. **Adesanya OO, Zhou J, Bondy CA**, Sex steroid regulation of IGF system gene expression and proliferation in

- primate myometrium, *J Clin Endocrinol Metab* 81:1967, 1996.
88. **Adesanya OO, Zhou J, Bondy CA**, Cellular localization and sex steroid regulation of insulin-like growth factor binding protein messenger ribonucleic acids in the primate myometrium, *J Clin Endocrinol Metab* 81:2495, 1996.
  89. **Raga F, Casan EM, Druessel JS, Wen Y, Huang HY, Nezhat C, Polan ML**, Quantitative gonadotropin-releasing hormone gene expression and immunohistochemical localization in human endometrium throughout the menstrual cycle, *Biol Reprod* 59:661, 1998.
  90. **Chou C-S, Tai C-J, MacCalman CD, Leung PCK**, Dose-dependent effects of gonadotropin releasing hormone on matrix metalloproteinase (MMP)-2, and MMP-9 and tissue specific inhibitor of metalloproteinases-1 messenger ribonucleic acid levels in human decidual stromal cells in vitro, *J Clin Endocrinol Metab* 88:680, 2003.
  91. **Cheung LW, Wong AS**, Gonadotropin-releasing hormone: GnRH receptor signaling in extrapituitary tissues, *FEBS J* 275:5479, 2008.
  92. **Casey ML, Mibe M, Erk A, MacDonald PC**, Transforming growth factor- $\beta$  stimulation of parathyroid hormone-related protein expression in human uterine cells in culture: mRNA levels and protein secretion, *J Clin Endocrinol Metab* 74:950, 1992.
  93. **Eldering JA, Nay MG, Hoberg LM, Longcope C, McCracken JA**, Hormonal regulation of prostaglandin production by Rhesus monkey endometrium, *J Clin Endocrinol Metab* 71:596, 1990.
  94. **Maathuis JB, Kelly RW**, Concentrations of prostaglandin F $2\alpha$  and E $2$  in the endometrium throughout the human menstrual cycle after the administration of clomiphene or an oestrogen-progesterone pill and in early pregnancy, *J Endocrinol* 77:361, 1978.
  95. **Levin JH, Stanczyk FZ, Lobo RA**, Estradiol stimulates the secretion of prostacyclin and thromboxane from endometrial stromal cells in culture, *Fertil Steril* 58:530, 1992.
  96. **Senior J, Sangha R, Baxter GS, Marshall K, Clayton JK**, In vitro characterization of prostanoid FP-, DP-, IP-, and TP-receptors on the non-pregnant human myometrium, *Br J Pharmacol* 107:215, 1992.
  97. **Swanson ML, Lei ZM, Swanson PH, Rao CV, Narumiya S, Hirata M**, The expression of thromboxane A $2$  synthase and thromboxane A $2$  receptor gene in human uterus, *Biol Reprod* 47:105, 1992.
  98. **Zhu HH, Huang JR, Mazella J, Elias J, Tseng L**, Progesterin stimulates the biosynthesis of fibronectin and accumulation of fibronectin mRNA in human endometrial cells, *Hum Reprod* 7:141, 1992.
  99. **Lessey BA, Damjanovich L, Coutifaris C, Castelbaum A, Albedla SM, Buck CA**, Integrin adhesion molecules in the human endometrium. Correlation with the normal and abnormal menstrual cycles, *J Clin Invest* 90:188, 1992.
  100. **Grosskinsky CM, Yowell CW, Sun J, Parise LV, Lessey BA**, Modulation of integrin expression in endometrial stromal cells in vitro, *J Clin Endocrinol Metab* 81:2047, 1996.
  101. **Economos K, MacDonald PC, Casey ML**, Endothelin-1 gene expression and protein biosynthesis in human endometrium: potential modulator of endometrial blood flow, *J Clin Endocrinol Metab* 74:14, 1992.
  102. **Kubota T, Kamada S, Hirata Y, Eguchi S, Imai T, Marumo F, Aso T**, Synthesis and release of endothelin-1 by human decidual cells, *J Clin Endocrinol Metab* 75:1230, 1992.
  103. **Reynolds LP, Killilea SD, Redmer DA**, Angiogenesis in the female reproductive system, *FASEB J* 6:886, 1992.
  104. **Reynolds LP, Redmer DA**, Angiogenesis in the placenta, *Biol Reprod* 64:1033, 2001.
  105. **Fraser HM, Duncan WC**, SRB reproduction, fertility and development award lecture 2008. Regulation and manipulation of angiogenesis in the ovary and endometrium, *Reprod Fertil Dev* 21:377, 2009.
  106. **Shifren JL, Tseng JF, Zaloudek CJ, Ryan IP, Meng YG, Ferrara N, Jaffe RB, Taylor RN**, Ovarian steroid regulation of vascular endothelial growth factor in the human endometrium: implications for angiogenesis during the menstrual cycle and in the pathogenesis of endometriosis, *J Clin Endocrinol Metab* 81:3112, 1996.
  107. **Punyadeera C, Thijssen VL, Tchaikovski S, Kamps R, Delvoux B, Dunselman GA, de Goeij AF, Groothuis PG**, Expression and regulation of vascular endothelial growth factor ligands and receptors during menstruation and post-menstrual repair of human endometrium, *Mol Hum Reprod* 12:367, 2006.

108. **Fan X, Krieg S, Kuo CJ, Wiegand SJ, Rabinovitch M, Druzin ML, Brenner RM, Giudice LC, Nayak NR**, VEGF blockade inhibits angiogenesis and reepithelialization of endometrium, *FASEB J* 22:3571, 2008.
109. **Fraser HM, Wilson H, Silvestri A, Morris KD, Wiegand SJ**, The role of vascular endothelial growth factor and estradiol in the regulation of endometrial angiogenesis and cell proliferation in the Marmoset, *Endocrinology* 149:4413, 2008.
110. **Lessey BA, Killiam AP, Metzger DA, Haney AF, Greene GL, McCarty KS**, Immunohistochemical analysis of uterine estrogen and progesterone receptors throughout the menstrual cycle, *J Clin Endocrinol Metab* 67:334, 1988.
111. **Snijders MPML, de Goeij AFPM, Debets-Te Baerts MJC, Rousch MJM, Koudstaal J, Bosman FT**, Immunocytochemical analysis of oestrogen receptors and progesterone receptors in the human uterus throughout the menstrual cycle and after the menopause, *J Reprod Fertil* 94:363, 1992.
112. **Lecce G, Meduri G, Ancelin M, Bergeron C, Perrot-Appianat M**, Presence of estrogen receptor  $\beta$  in the human endometrium through the cycle: expression in glandular, stromal, and vascular cells, *J Clin Endocrinol Metab* 86:1379, 2001.
113. **Horie K, Takakura K, Imai K, Liao S, Mori T**, Immunohistochemical localization of androgen receptor in the human endometrium, decidua, placenta and pathological conditions of the endometrium, *Hum Reprod* 7:1461, 1992.
114. **Brenner R, Slayden O, Nayak N, Baird D, Critchley H**, A role for the androgen receptor in the endometrial antiproliferative effects of progesterone antagonists, *Steroids* 68:1033, 2003.
115. **Catalano RD, Critchley HO, Heikinheimo O, Baird DT, Hapangama D, Sherwin JR, Charnock-Jones DS, Smith SK, Sharkey AM**, Mifepristone induced progesterone withdrawal reveals novel regulatory pathways in human endometrium, *Mol Hum Reprod* 13:641, 2007.
116. **Groothuis PG, Dassen HHNM, Romano A, Punyadeera C**, Estrogen and the endometrium: lessons learned from gene expression profiling in rodents and human, *Hum Reprod Update* 13:405, 2007.
117. **Park S, Yoon S, Zhao Y, Park SE, Liao L, Xu J, Lydon JP, DeMayo FJ, O'Malley BW, Bagchi MK, Katzenellenbogen BS**, Uterine development and fertility are dependent on gene dosage of the nuclear receptor coregulator REA. *Endocrinology* 153:3982, 2012.
118. **Mukherjee A, Amato P, Allred DC, Fernandez-Valdivia R, Nguyen J, O'Malley BW, DeMayo FJ, Lydon JP**, Steroid receptor coactivator 2 is essential for progesterone-dependent uterine function and mammary morphogenesis: insights from the mouse—implications for the human, *J Steroid Biochem Mol Biol* 102:22, 2006.
119. **Jones RL, Findlay JK, Salamonsen LA**, The role of activins during decidualisation of human endometrium, *Aust N Z J Obstet Gynaecol* 46:245, 2006.
120. **Stoikos CJ, Harrison CA, Salamonsen LA, Dimitriadis E**, A distinct cohort of the TGFbeta superfamily members expressed in human endometrium regulate decidualization, *Hum Reprod* 23:1447, 2008.
121. **Tawadros N, Salamonsen LA, Dimitriadis E, Chen C**, Facilitation of decidualization by locally produced ghrelin in the human endometrium, *Mol Hum Reprod* 13:483, 2007.
122. **Geisert R, Fazleabas A, Lucy M, Mathew D**, Interaction of the conceptus and endometrium to establish pregnancy in mammals: role of interleukin 1 $\beta$ , *Cell Tissue Res* 349:825, 2012.
123. **Shuya LL, Menkhorst EM, Yap J, Li P, Lane N, Dimitriadis E**, Leukemia inhibitory factor enhances endometrial stromal cell decidualization in humans and mice, *PLoS One* 6:e25288, 2001.
124. **Afshar Y, Jeong JW, Roqueiro D, DeMayo F, Lydon J, Radtke F, Radnor R, Miele L, Fazleabas A**, Notch1 mediates uterine stromal differentiation and is critical for complete decidualization in the mouse, *FASEB J* 26:282, 2012.
125. **Eun Kwon H, Taylor HS**, The role of HOX genes in human implantation, *Ann N Y Acad Sci* 1034:1, 2004.
126. **Taylor HS**, The role of HOX genes in human implantation, *Hum Reprod Update* 6(1):75, 2000.
127. **Taylor HS, Igarashi P, Olive DL, Arici A**, Sex steroids mediate HOXA11 expression in the human peri-implantation endometrium, *J Clin Endocrinol Metab* 84(3):1129, 1999.
128. **Taylor HS, Arici A, Olive D, Igarashi P**, HOXA10 is expressed in response to sex steroids at the time of implantation in the human endometrium, *J Clin Invest* 101(7):1379, 1998.

129. **Handwerger S, Richards RG, Markoff E**, The physiology of decidual prolactin and other decidual protein hormones, *Trends Endocrinol Metab* 3:91, 1992.
130. **Handwerger S, Harman I, Golander A, Handwerger DA**, Prolactin release from perfused human decidual explants: effects of decidual prolactin-releasing factor (PRL-RF) and prolactin release-inhibitory factor (PRL-IF), *Placenta* 13:55, 1992.
131. **Riddick DH, Kusmik WF**, Decidua: a possible source of amniotic fluid prolactin, *Am J Obstet Gynecol* 127:187, 1977.
132. **Eyal O, Jomain JB, Kessler C, Goffin V, Handwerger S**, Autocrine prolactin inhibits human uterine decidualization: a novel role for prolactin, *Biol Reprod* 76:777, 2007.
133. **Pihoker C, Pheeny R, Handwerger S**, Lipocortin 1 inhibits the synthesis and release of prolactin from human decidual cells, *Endocrinology* 128:1123, 1991.
134. **Riddick DH, Luciano AA, Kusmik WF, Maslar IA**, De novo synthesis of prolactin by human decidua, *Life Sci* 23:1913, 1978.
135. **Braverman MB, Bagni A, de Ziegler D, Den T, Gurpide E**, Isolation of prolactin-producing cells from first and second trimester decidua, *J Clin Endocrinol Metab* 58:521, 1984.
136. **Wu WX, Brooks J, Glasier AF, McNeilly AS**, The relationship between decidualization and prolactin mRNA and production at different stages of human pregnancy, *J Mol Endocrinol* 14:255, 1995.
137. **Stefanoska I, Jovanović Krivokuća M, Vasilijić S, Čujić D, Vićovac L**, Prolactin stimulates cell migration and invasion by human trophoblast in vitro, *Placenta* 34:775, 2013.
138. **Corbacho AM, Martínez De La Escalera GM, Clapp C**, Roles of prolactin and related members of the prolactin/growth hormone/placental lactogen family in angiogenesis, *J Endocrinol* 173:219, 2002.
139. **Taylor CM, McLaughlin B, Weiss JB, Maroudas NG**, Concentrations of endothelial-cell-stimulating angiogenesis factor, a major component of human uterine angiogenesis factor, in human and bovine embryonic tissues and decidua, *J Reprod Fertil* 94:445, 1992.
140. **Petraglia F, Tabanelli S, Galassi MC, Garuti GC, Mancini AC, Genazzani AR, Gurpide E**, Human decidua and in vitro decidualized endometrial stromal cells at term contain immunoreactive corticotropin-releasing factor (CRF) and CRF messenger ribonucleic acid, *J Clin Endocrinol Metab* 74:1427, 1992.
141. **Poisner AM, Thrailkill K, Poisner R, Handwerger S**, Cyclic AMP and protein kinase C as second messengers for prorenin release from human decidual cells, *Placenta* 12:263, 1991.
142. **Chao H-S, Poisner A, Poisner R, Handwerger S**, Endothelins stimulate the synthesis and release of prorenin from human decidual cells, *J Clin Endocrinol Metab* 76:615, 1993.
143. **Li CI, Ansari R, Yu Z, Shah D**, Definitive molecular evidence of renin-angiotensin system in human uterine decidual cells, *Hypertension* 36:159, 2000.
144. **Giudice LC, Dsupin BA, Irwin JC**, Steroid and peptide regulation of insulin-like growth factor-binding proteins secreted by human endometrial cells is dependent on stromal differentiation, *J Clin Endocrinol Metab* 75: 1235, 1992.
145. **Tseng L, Gao J-G, Chen R, Zhu HH, Mazella J, Powell DR**, Effect of progestin, antiprogestin, and relaxin on the accumulation of prolactin and insulin-like growth factor-binding protein-1 messenger ribonucleic acid in human endometrial cells, *Biol Reprod* 47:441, 1992.
146. **Thrailkill KM, Clemmons DR, Busby WH Jr, Handwerger S**, Differential regulation of insulin-like growth factor binding protein secretion from human decidual cells by IGF-I, insulin, and relaxin, *J Clin Invest* 86:878, 1990.
147. **Matsumoto H, Sakai K, Iwashita M**, Insulin-like growth factor binding protein-1 induces decidualization of human endometrial stromal cells via alpha5beta1 integrin, *Mol Hum Reprod* 14:485, 2008.
148. **Pekonen F, Nyman T, Lahteenmaki P, Haukkamaa M, Rutanen E-M**, Intrauterine progestin induces continuous insulin-like growth factor-binding protein-1 production in the human endometrium, *J Clin Endocrinol Metab* 75:660, 1992.
149. **Moy E, Kimzey LM, Nelson LM, Blithe DL**, Glycoprotein hormone alpha-subunit functions synergistically with progesterone to stimulate differentiation of cultured human endometrial stromal cells to decidualized cells: a novel role for free alpha-subunit in reproduction, *Endocrinology* 137:1332, 1996.

150. **Blithe DL, Richards RG, Sklarulis MC**, Free alpha molecules from pregnancy stimulate secretion of prolactin from human decidual cells: a novel function for free alpha in pregnancy, *Endocrinology* 129:2257, 1992.
151. **Kauma S, Matt D, Strom S, Eirman D, Turner T**, Interleukin-1 $\beta$ , human leukocyte antigen HLA-DR alpha, and transforming growth factor- $\beta$  expression in endometrium, placenta, and placental membranes, *Am J Obstet Gynecol* 163:1430, 1990.
152. **Graham CH, Lysiak JJ, McCrae KR, Lal PK**, Localization of transforming growth factor-beta at the human fetal-maternal interface: role in trophoblast growth and differentiation, *Biol Reprod* 46:561, 1992.
153. **Graham CH, McCrae KR, Lala PK**, Molecular mechanisms of controlling trophoblast invasion of the uterus, *Placenta* 14:237, 1993.
154. **Heinonen PK, Saarikoski S, Pystynen P**, Reproductive performance of women with uterine anomalies. An evaluation of 182 cases, *Acta Obstet Gynecol Scand* 61:157, 1982.
155. **Rock JA, Schlaff WD**, The obstetrical consequences of utero-vaginal anomalies, *Fertil Steril* 43:681, 1985.
156. **Golan A, Langer R, Bukovsky I, Caspi E**, Congenital anomalies of the müllerian system, *Fertil Steril* 51:747, 1989.
157. **Acién P**, Reproductive performance of women with uterine malformations, *Hum Reprod* 8:122, 1993.
158. **Acién P**, Incidence of Müllerian defects in fertile and infertile women, *Hum Reprod* 12:1372, 1997.
159. **Rackow BW, Arici A**, Reproductive performance of women with müllerian anomalies, *Curr Opin Obstet Gynecol* 19:229, 2007.
160. **Salim R, Regan L, Woelfer B, Backos M, Jurkovic D**, A comparative study of the morphology of congenital uterine anomalies in women with and without a history of recurrent first trimester miscarriage, *Hum Reprod* 18:162, 2003.
161. **Grimbizis GF, Camus M, Tarlatzis BC, Bontis JN, Devroey P**, Clinical implications of uterine malformations and hysteroscopic treatment results, *Hum Reprod Update* 7:161, 2001.
162. **The American Society for Reproductive Medicine**, Classifications of adnexal adhesions, distal tubal occlusion, tubal occlusion secondary to tubal ligation, tubal pregnancies, müllerian anomalies and intrauterine adhesions, *Fertil Steril* 49:944, 1988.
163. **Creatas G, Cardamakis E, Hassan E, Deligeoroglou E, Salakos N, Aravantinos D**, Congenital uterine anomalies with obstructed cervix, hemivagina, or both during adolescence: report of 22 cases, *J Gynecol Surg* 10:159, 1994.
164. **Vercellini P, Daguati R, Somigliana E, Viganò P, Lanzani A, Fedele L**, Asymmetric lateral distribution of obstructed hemivagina and renal agenesis in women with uterus didelphys: institutional case series and a systematic literature review, *Fertil Steril* 87(4):719, 2007.
165. **Raga F, Bauset C, Remohi J, Bonilla-Musoles F, Simón C, Pellicer A**, Reproductive impact of congenital Müllerian anomalies, *Hum Reprod* 12:2277, 1997.
166. **Heinonen P**, Clinical implications of the didelphic uterus: long-term follow-up of 49 cases, *Eur J Obstet Gynecol Reprod Biol* 91:183, 2000.
167. **Andrews MC, Jones HW Jr**, Impaired reproductive performance of the unicornuate uterus: intrauterine growth retardation, infertility, and recurrent abortion in five cases, *Am J Obstet Gynecol* 144:173, 1982.
168. **Heinonen PK**, Unicornuate uterus and rudimentary horn, *Fertil Steril* 68:224, 1997.
169. **Akar ME, Bayar D, Yildiz S, Ozel M, Yilmaz Z**, Reproductive outcome of women with unicornuate uterus, *Aust N Z J Obstet Gynaecol* 45:148, 2005.
170. **Jayasinghe Y, Rane A, Stalewski H, Grover S**, The presentation and early diagnosis of the rudimentary uterine horn, *Obstet Gynecol* 105:1456, 2005.
171. **Fedele L, Bianchi S, Agnoli B, Tozzi L, Vignali M**, Urinary tract anomalies associated with unicornuate uterus, *J Urol* 155:847, 1996.
172. **Woelfer B, Salim R, Banerjee S, Elson J, Regan L, Jurkovic D**, Reproductive outcomes in women with congenital uterine anomalies detected by three-dimensional ultrasound screening, *Obstet Gynecol* 98:1099, 2001.
173. **Heinonen PK**, Complete septate uterus with longitudinal vaginal septum, *Fertil Steril* 85:700, 2006.

174. **Tomazevic T, Ban-Frangez H, Ribic-Puceij M, Premru-Srsen T, Verdenik I**, Small uterine septum is an important risk variable for preterm birth, *Eur J Obstet Gynecol Reprod Biol* 135:154, 2007.
175. **Daly DC, Maier D, Soto-Albors C**, Hysteroscopic metroplasty: six years experience, *Obstet Gynecol* 73:201, 1989.
176. **Fedele L, Bianchi S**, Hysteroscopic metroplasty for septate uterus, *Obstet Gynecol Clin North Am* 22:473, 1995.
177. **Patton PE, Novy MJ, Lee DM, Hickok LR**, The diagnosis and reproductive outcome after surgical treatment of the complete septate uterus, duplicated cervix and vaginal septum, *Am J Obstet Gynecol* 190:1669, 2004.
178. **Pace S, Cipriano L, Pace G, Catania R, Montanino G**, Septate uterus: reproductive outcome after hysteroscopic metroplasty, *Clin Exp Obstet Gynecol* 33:110, 2006.
179. **Mollo A, De Franciscis P, Colacurci N, Cobellis L, Perino A, Venezia R, Alviggi C, De Placido G**, Hysteroscopic resection of the septum improves the pregnancy rate of women with unexplained infertility: a prospective controlled trial, *Fertil Steril* 91(6):2628, 2009.
180. **Prior M, Richardson A, Asif S, Polanski L, Parris-Larkin M, Chandler J, Fogg L, Jassal P, Thornton JG, Raine-Fenning NJ**, Outcome of assisted reproduction in women with congenital uterine anomalies: a prospective observational study, *Ultrasound Obstet Gynecol* 51(1):110, 2018.
181. **Rock JA, Schlaff WD, Zacur HA, Jones HW Jr**, The clinical management of congenital absence of the uterine cervix, *Int J Gynaecol Obstet* 22:231, 1984.
182. **Deffarges JV, Haddad B, Musset R, Paniel BJ**, Utero-vaginal anastomosis in women with uterine cervix atresia: long-term follow-up and reproductive performance: a study of 18 cases, *Hum Reprod* 16:1722, 2001.
183. **Kaufman RH, Adan E, Binder GL, Gerthoffer E**, Upper genital tract changes and pregnancy outcome in offspring exposed in utero to diethylstilbestrol, *Am J Obstet Gynecol* 137:299, 1980.
184. **Goldberg JM, Falcone T**, Effect of diethylstilbestrol on reproductive function, *Fertil Steril* 72:1, 1999.
185. **Pellerito JS, McCarthy SM, Doyle MB, Glickman MG, DeCherney AH**, Diagnosis of uterine anomalies: relative accuracy of MR imaging, endovaginal sonography, and hysterosalpingography, *Radiology* 183:795, 1992.
186. **Troiano RN, McCarthy SM**, Müllerian duct anomalies: imaging and clinical issues, *Radiology* 233:19, 2004.
187. **Ghi T, Casadio P, Kuleva M, Perrone AM, Savelli L, Giunchi S, Meriggiola MC, Gubbini G, Pilu G, Pelusi C, Pelusi G**, Accuracy of three-dimensional ultrasound in diagnosis and classification of congenital uterine anomalies, *Fertil Steril* 92(2):808, 2009.
188. **Barbieri RL, Andersen J**, Uterine leiomyomas: the somatic mutation theory, *Semin Reprod Endocrinol* 10:301, 1992.
189. **Andersen J, Barbieri RL**, Abnormal gene expression in uterine leiomyomas, *J Soc Gynecol Investig* 2:663, 1995.
190. **Hashimoto K, Azuma C, Kamiura S, Kimura T, Nobunaga T, Kanai T, Sawada M, Noguchi S, Saji F**, Clonal determination of uterine leiomyomas by analyzing differential inactivation of the X-chromosome-linked phosphoglycerokinase gene, *Gynecol Obstet Invest* 40:204, 1995.
191. **Vikhlyeva EM, Khodzhaeva ZS, Fantschenko ND**, Familial predisposition to uterine leiomyomas, *Int J Gynaecol Obstet* 51:127, 1995.
192. **Treloar SA, Do KA, Martin NG**, Genetic influences on the age at menopause, *Lancet* 352:1084, 1998.
193. **Toro JR, Nickerson ML, Wei MH, Warren MB, Glenn GM, Turner ML, Stewart L, Duray P, Tourre O, Sharma N, Choyke P, Stratton P, Merino M, Walther MM, Linehan WM, Schmidt LS, Zbar B**, Mutations in the fumarate hydratase gene cause hereditary leiomyomatosis and renal cell cancer in families in North America, *Am J Hum Genet* 73:95, 2003.
194. **Stewart L, Glenn GM, Stratton P, Goldstein AM, Merino MJ, Tucker MA, Linehan WM, Toro JR**, Association of germline mutations in the fumarate hydratase gene and uterine fibroids in women with hereditary leiomyomatosis and renal cell cancer, *Arch Dermatol* 144:1584, 2008.
195. **Cha PC, Takahashi A, Hosono N, Low SK, Kamatani N, Kubo M, Nakamura Y**, A genome-wide association study identifies three loci associated with susceptibility to uterine fibroids, *Nat Genet* 2011;43:447.



196. **Eggert SL, Huyck KL, Somasundaram P, Kavalla R, Stewart EA, Lu AT, Painter JN, Montgomery GW, Medland SE, Nyholt DR, Treloar SA, Zondervan KT, Heath AC, Madden PA, Rose L, Buring JE, Ridker PM, Chasman DI, Martin NG, Cantor RM, Morton CC**, Genome-wide linkage and association analyses implicate FASN in predisposition to Uterine Leiomyomata, *Am J Hum Genet* 91:621, 2012.
197. **Hodge JC, Morton CC**, Genetic heterogeneity among uterine leiomyomata: insights into malignant progression, *Hum Mol Genet* 16(Rev Issue 1):R7, 2007.
198. **Mäkinen N, Mehine M, Tolvanen J, Kaasinen E, Li Y, Lehtonen HJ, Gentile M, Yan J, Enge M, Taipale M, Aavikko M, Katainen R, Virolainen E, Böhling T, Koski TA, Launonen V, Sjöberg J, Taipale J, Vahteristo P, Aaltonen LA**, MED12, the mediator complex subunit 12 gene, is mutated at high frequency in uterine leiomyomas, *Science* 334(6053):252, 2011.
199. **Parker WH, Fu YS, Berek JS**, Uterine sarcoma in patients operated on for presumed leiomyoma and rapidly growing leiomyoma, *Obstet Gynecol* 83:414, 1994.
200. **Quade BJ, Wang TY, Sornberger K, Dal Cin P, Mutter GL, Morton CC**, Molecular pathogenesis of uterine smooth muscle tumors from transcriptional profiling, *Genes Chromosomes Cancer* 40:97, 2004.
201. **Cramer SF, Patel D**, The frequency of uterine leiomyomas, *Am J Clin Pathol* 94:435, 1990.
202. **Day Baird D, Dunson DB, Hill MC, Cousins D, Schectman JM**, High cumulative incidence of uterine leiomyoma in black and white women: ultrasound evidence, *Am J Obstet Gynecol* 188:100, 2003.
203. **Farquhar CM, Steiner CA**, Hysterectomy rates in the United States 1990–1997, *Obstet Gynecol* 99:229, 2002.
204. **Cramer DW**, Epidemiology of myomas, *Semin Reprod Endocrinol* 10:320, 1992.
205. **Marshall LM, Spiegelman D, Barbieri RL, Goldman MB, Manson JE, Colditz GA, Willett WC, Hunter DJ**, Variation in the incidence of uterine leiomyoma among premenopausal women by age and race, *Obstet Gynecol* 90:967, 1997.
206. **Palmer JR, Rao RS, Adams-Campbell LL, Rosenberg L**, Correlates of hysterectomy among African-American women, *Am J Epidemiol* 150:1309, 1999.
207. **Vergani P, Ghidini A, Strobelt N, Roneaglia N, Locatelli A, Lapinski R, Mangioni C**, Do uterine leiomyomas influence pregnancy outcome?, *Am J Perinatol* 11:356, 1994.
208. **Selo-Ojeme DO, Lawal O, Shah J, Mandal R, Pathak S, Selo-Ojeme U, Samuel D**, The incidence of uterine leiomyoma and other pelvic ultrasonographic findings in 2,034 consecutive women in a north London hospital, *J Obstet Gynaecol* 28:421, 2008.
209. **Marshall LM, Spiegelman D, Goldman MB, Manson JE, Colditz GA, Barbieri RL, Stampfer MJ, Hunter DJ**, A prospective study of reproductive factors and oral contraceptive use in relation to the risk of uterine leiomyomata, *Fertil Steril* 70:432, 1998.
210. **Parazzini F, Negri E, La Vecchia C, Fedele L, Rabaiotti M, Luchini L**, Oral contraceptive use and risk of uterine fibroids, *Obstet Gynecol* 79:430, 1992.
211. **Samadi AR, Lee NC, Flanders D, Boring JR III, Parris EB**, Risk factors for self-reported uterine fibroids: a case-control study, *Am J Public Health* 86:858, 1996.
212. **Otubu JA, Buttram VC, Besch NF, Besch PK**, Unconjugated steroids in leiomyomas and tumor-bearing myometrium, *Am J Obstet Gynecol* 143:130, 1982.
213. **Rein MS, Friedman AJ, Stuart JM, MacLaughlin DT**, Fibroid and myometrial steroid receptors in women treated with the gonadotropin-releasing hormone agonist leuprolide acetate, *Fertil Steril* 53:1018, 1990.
214. **Brandon DD, Erickson TE, Keenan EJ, Strawn EY, Novy MJ, Burry KA, Warner C, Clinton CM**, Estrogen receptor gene expression in human uterine leiomyomata, *J Clin Endocrinol Metab* 80:1876, 1995.
215. **Bakas P, Liapis A, Vlahopoulos S, Giner M, Logotheti S, Creatsas G, Meligova AK, Alexis MN, Zoumpourlis V**, Estrogen receptor  $\alpha$  and  $\beta$  in uterine fibroids: a basis for altered estrogen responsiveness, *Fertil Steril* 90:1878, 2008.
216. **Bulun SE, Simpson ER, Word RA**, Expression of the CYP 19 gene and its product aromatase cytochrome P450 in human uterine leiomyoma tissues and cells in culture, *J Clin Endocrinol Metab* 78:736, 1994.
217. **Andersen J, DyReyes VM, Barbieri RL, Coachman DM, Miksicek RJ**, Leiomyoma primary cultures have elevated transcriptional response to estrogen compared with autologous myometrial cultures, *J Soc*

Gynecol Investig 2: 542, 1995.

218. **Deligdish L, Loewenthal M**, Endometrial changes associated with myomata of the uterus, *J Clin Pathol* 23:676, 1970.
219. **Kawaguchi K, Fujii S, Konishi I, Nanbu Y, Nonogaki H, Mori T**, Mitotic activity in uterine leiomyomas during the menstrual cycle, *Am J Obstet Gynecol* 160:637, 1989.
220. **Tiltman AJ**, The effect of progestins on the mitotic activity of uterine fibromyomas, *Int J Gynecol Pathol* 4:89, 1985.
221. **Brandon DD, Bethea CL, Strawn EY, Novy MJ, Burry KA, Harrington MS, Erickson TE, Warner C, Keenan EJ, Clinton GM**, Progesterone receptor messenger ribonucleic acid and protein are overexpressed in human uterine leiomyomas, *Am J Obstet Gynecol* 169:78, 1993.
222. **Viville B, Charnock-Jones DS, Sharkey AM, Wetzka B, Smith SK**, Distribution of the A and B forms of the progesterone receptor messenger ribonucleic acid and protein in uterine leiomyomata and adjacent myometrium, *Hum Reprod* 12:815, 1997.
223. **Murphy AA, Morales AJ, Kettel LM, Yen SS**, Regression of uterine leiomyomata to the antiprogestosterone RU486: dose-response effect, *Fertil Steril* 64:187, 1995.
224. **Chwalisz K, Larsen L, Mattia-Goldberg C, Edmonds A, Elger W, Winkel CA**, A randomized, controlled trial of asoprisnil, a novel selective progesterone receptor modulator, in women with uterine leiomyomata, *Fertil Steril* 87:1399, 2007.
225. **Yin P, Lin Z, Cheng YH, Marsh EE, Utsunomiya H, Ishikawa H, Xue Q, Reierstad S, Innes J, Thung S, Kim JJ, Xu E, Bulun SE**, Progesterone receptor regulates Bcl-2 gene expression through direct binding to its promoter region in uterine leiomyoma cells, *J Clin Endocrinol Metab* 92:4459, 2007.
226. **Matsuo H, Maruo T, Samoto T**, Increased expression of Bcl-2 protein in human uterine leiomyoma and its up-regulation by progesterone, *J Clin Endocrinol Metab* 82:193, 1997.
227. **Andersen J**, Growth factors and cytokines in uterine leiomyomas, *Semin Reprod Endocrinol* 14:269, 1996.
228. **Lumsden MA, West CP, Bramley T, Rungay L, Baird DT**, The binding of epidermal growth factor to the human uterus and leiomyomata in women rendered hypoestrogenic by continuous administration of an LHRH agonist, *Br J Obstet Gynaecol* 95:1299, 1988.
229. **Harrison-Woolrych ML, Charnock-Jones DS, Smith SK**, Quantification of messenger ribonucleic acid for epidermal growth factor in human myometrium and leiomyomata using reverse transcriptase polymerase chain reaction, *J Clin Endocrinol Metab* 78:1179, 1994.
230. **Gludemans T, Prinsen I, Van Unmik JAM, Lips CJ, Den Otter W, Sussenbach JS**, Insulin-like growth factor gene expression in human smooth muscle tumors, *Cancer Res* 50:6689, 1990.
231. **Giudice LC, Irwin JC, Dsupin BA, Pannier EM, Jin IH, Vu TH, Hoffman AR**, Insulin-like growth factor (IGF), IGF binding protein (IGFBP), and IGF receptor gene expression and IGFBP synthesis in human uterine leiomyomata, *Hum Reprod* 8:1796, 1993.
232. **Vollenhoven BJ, Herington AC, Healy DL**, Messenger ribonucleic acid expression of the insulin-like growth factors and their binding proteins in uterine fibroids and myometrium, *J Clin Endocrinol Metab* 76:1106, 1993.
233. **Weir EC, Goad DL, Daifotis AG, Burtis WJ, Dreyer BE, Nowak RA**, Relative overexpression of the parathyroid hormone-related protein gene in human leiomyomas, *J Clin Endocrinol Metab* 78:784, 1994.
234. **Tal R, Segars JH**, The role of angiogenic factors in fibroid pathogenesis: potential implications for future therapy, *Hum Reprod Update* 20(2):194, 2014. doi: 10.1093/humupd/dmt042c.
235. **Jabbour HN, Critchley HO**, Potential roles of decidual prolactin in early pregnancy, *Reproduction* 121:197, 2001.
236. **Schmid CH, Beham A, Kratochvil P**, Haematopoiesis in a degenerating uterine leiomyomata, *Arch Gynecol Obstet* 248:81, 1990.
237. **Stewart EA, Nowak RA**, Leiomyoma-related bleeding: a classic hypothesis updated for the molecular era, *Hum Reprod Update* 2:296, 1996.
238. **Sampson JA**, The blood supply of uterine myomata, *Surg Gynecol Obstet* XIV:15, 1912.
239. **Faulkner RL**, The blood vessels of the myomatous uterus, *Am J Obstet Gynecol* 47:185, 1944.

240. **Farrer-Brown G, Beilby JO, Tarbit MH**, The vascular patterns in myomatous uteri, *J Obstet Gynaecol Br Commonw* 77:967, 1970.
241. **Mayer A, Hoeckel M, vonWallbrunn A, Horn LC, Wree A, Vaupel P**, HIF-mediated hypoxic response is missing in severely hypoxic uterine leiomyomas, *Adv Exp Med Biol* 662:399, 2010.
242. **Chen HW, Liu JC, Chen JJ, Lee Y, Hwang JL, Tzeng CR**, Combined differential gene expression profile and pathway enrichment analyses to elucidate the molecular mechanisms of uterine leiomyoma after gonadotropin-releasing hormone treatment, *Fertil Steril* 90:1219, 2008.
243. **Buttram VC, Reiter RC**, Uterine leiomyomata: etiology, symptomatology and management, *Fertil Steril* 36:433, 1981.
244. **Pritts EA**, Fibroids and infertility: a systematic review of the evidence, *Obstet Gynecol Surv* 56:483, 2001.
245. **Verkauf BS**, Myomectomy for fertility enhancement and preservation, *Fertil Steril* 58:1, 1992.
246. **Zawin M, McCarthy S, Scoutt LM, Comite F**, High-field MRI and US evaluation of the pelvis in women with leiomyomas, *Magn Reson Imaging* 8:371, 1990.
247. **Fedele L, Bianchi S, Dorta M, Brioschi D, Zanottie F, Vercellini P**, Transvaginal ultrasonography versus hysteroscopy in the diagnosis of uterine submucous myomas, *Obstet Gynecol* 77:745, 1991.
248. **Fauconnier A, Chapron C, Babaki-Fard K, Dubuisson J-B**, Recurrence of leiomyomata after myomectomy, *Hum Reprod Update* 6:595, 2000.
249. **Candiani GB, Fedele L, Parazzini F, Villa L**, Risk of recurrence after myomectomy, *Br J Obstet Gynaecol* 98:385, 1991.
250. **Fedele L, Parazzini F, Luchini L, Mezzopane R, Tozzi L, Villa L**, Recurrence of fibroids after myomectomy: a transvaginal ultrasonographic study, *Hum Reprod* 10:1795, 1995.
251. **Rackow BW, Taylor HS**, Submucosal uterine leiomyomas have a global effect on molecular determinants of endometrial receptivity, *Fertil Steril* 93(6):2027, 2010.
252. **Doherty LF, Taylor HS**, Leiomyoma-derived transforming growth factor- $\beta$  impairs bone morphogenetic protein-2-mediated endometrial receptivity, *Fertil Steril* 103(3):845, 2015.
253. **Sinclair DC, Mastroyannis A, Taylor HS**, Leiomyoma simultaneously impair endometrial BMP-2-mediated decidualization and anticoagulant expression through secretion of TGF- $\beta$ 3, *J Clin Endocrinol Metab* 96(2):412, 2011.
254. **Taylor HS**, Fibroids: when should they be removed to improve in vitro fertilization success? *Fertil Steril* 109(5):784, 2018.
255. **Klatsky PC, Lane DE, Ryan IP, Fujimoto VY**, The effect of fibroids without cavity involvement on ART outcomes independent of ovarian age, *Hum Reprod* 22:521, 2007.
256. **Horcajadas JA, Goyri E, Higón MA, Martinez-Conejero JA, Gambadauro P, Garcia G, Meseguer M, Simón C, Pellicer A**, Endometrial receptivity and implantation are not affected by the presence of uterine intramural leiomyomas: a clinical and functional genomics analysis, *J Clin Endocrinol Metab* 93:3490, 2008.
257. **Rossi G, Diamond MP**, Myomas, reproductive function, and pregnancy, *Semin Reprod Endocrinol* 10:332, 1992.
258. **Qidwai GI, Caughey AB, Jacoby AF**, Obstetric outcomes in women with sonographically identified uterine leiomyomata, *Obstet Gynecol* 107:376, 2006.
259. **Klatsky PC, Tran ND, Caughey AB, Fujimoto VY**, Fibroids and reproductive outcomes: a systematic literature review from conception to delivery, *Am J Obstet Gynecol* 198:357, 2008.
260. **Katz VL, Dotters DJ, Droegemueller W**, Complications of uterine leiomyomas in pregnancy, *Obstet Gynecol* 73:593, 1989.
261. **Rice JP, Kay HH, Mahony BS**, The clinical significance of uterine leiomyomas in pregnancy, *Am J Obstet Gynecol* 160:1212, 1989.
262. **Stewart EA, Friedman AJ**, Steroidal treatment of myomas: preoperative and long-term medical therapy, *Semin Reprod Endocrinol* 10:344, 1992.
263. **Gurates B, Parmaksiz C, Kilic G, Celik H, Kumru S, Simsek M**, Treatment of symptomatic uterine leiomyoma with letrozole, *Reprod Biomed Online* 17: 569, 2008.
264. **Lethaby A, Vollenhoven B, Sowter M**, Efficacy of pre-operative gonadotropin hormone releasing analogues

for women with uterine fibroids undergoing hysterectomy or myomectomy: a systematic review, *Br J Obstet Gynaecol* 109: 1097, 2002.

265. **Ylikorkala O, Tiitinen A, Hulko S, Kivinen S, Nummi S**, Decrease in symptoms, blood loss and uterine size with nafarelin acetate before abdominal hysterectomy: a placebo-controlled, double-blind study, *Hum Reprod* 10 1470, 1995.
266. **Benagiano G, Kivinen ST, Fadini R, Cronje H, Klintorp S, van der Spuy ZM**, Zoladex (goserelin acetate) and the anemic patient: results of a multicenter fibroid study, *Fertil Steril* 66:223, 1996.
267. **Matta WH, Stabile I, Shaw RW, Campbell S**, Doppler assessment of uterine blood flow changes in patients with fibroids receiving the gonadotropin-releasing hormone agonist Buserelin, *Fertil Steril* 49:1083, 1988.
268. **Khan KN, Kitajima M, Hiraki K, Fujishita A, Sekine I, Ishimaru T, Masuzaki H**, Changes in tissue inflammation, angiogenesis and apoptosis in endometriosis, adenomyosis and uterine myoma after GnRH agonist therapy, *Hum Reprod* 25:642, 2010.
269. **Hales HA, Peterson CM, Jones KP, Quinn JD**, Leiomyomatosis peritonealis disseminata treated with a gonadotropin-releasing hormone agonist, *Am J Obstet Gynecol* 167:515, 1992.
270. **Hirata JD, Moghissi KS, Ginsburg KA**, Pregnancy after medical therapy of adenomyosis with a gonadotropin-releasing hormone agonist, *Fertil Steril* 59:444, 1993.
271. **Nelson JR, Corson SL**, Long-term management of adenomyosis with a gonadotropin-releasing hormone agonist: a case report, *Fertil Steril* 59:441, 1993.
272. **Letterie GS, Stevenson D, Shah A**, Recurrent anaphylaxis to a depot form of GnRH analogue, *Obstet Gynecol* 78:943, 1991.
273. **Friedman AJ**, Vaginal hemorrhage associated with degenerating submucous leiomyomata during leuprolide acetate treatment, *Fertil Steril* 52:152, 1989.
274. **Schwartz LB, Diamond MP, Schwartz PE**, Leiomyosarcomas: clinical presentation, *Am J Obstet Gynecol* 168:180, 1993.
275. **Har-Toov J, Brenner SH, Jaffa A, Yavetz H, Peyser MR, Lessing JB**, Pregnancy during long-term gonadotropin-releasing hormone agonist therapy associated with clinical pseudomenopause, *Fertil Steril* 59:446, 1993.
276. **Friedman AJ, Daly M, Juneau-Norcross M, Gleason R, Rein MS, LeBoff M**, Long-term medical therapy for leiomyomata uteri: a prospective, randomized study of leuprolide acetate depot plus either oestrogen-progestin or progestin 'add-back' for 2 years, *Hum Reprod* 9:1618, 1994.
277. **Palomba S, Affinito P, Tommaselli GA, Nappi C**, A clinical trial of the effects of tibolone administered with gonadotropin-releasing hormone analogues for the treatment of uterine leiomyomata, *Fertil Steril* 70:111, 1998.
278. **Palomba S, Russo T, Orio F Jr, Tauchmanova L, Zupi E, Panici PLB, Nappi C, Colao A, Lombardi G, Zullo F**, Effectiveness of combined GnRH analogue plus raloxifene administration in the treatment of uterine leiomyomas: a prospective, randomized, single-blind, placebo-controlled clinical trial, *Hum Reprod* 17:3213, 2002.
279. **Palomba S, Orio F Jr, Morelli M, Russo T, Pellicano M, Zupi E, Lombardi G, Nappi C, Panici PL, Zullo F**, Raloxifene administration in premenopausal women with uterine leiomyomas: a pilot study, *J Clin Endocrinol Metab* 87:3603, 2002.
280. **Palomba S, Sammartino A, Di Carlo C, Affinito P, Zullo F, Nappi C**, Effects of raloxifene treatment on uterine leiomyomas in postmenopausal women, *Fertil Steril* 76:38, 2001.
281. **Palomba S, Morelli M, Di Carlo C, Noia R, Pellicano M, Zullo F**, Bone metabolism in postmenopausal women who were treated with a gonadotropin-releasing hormone agonist and tibolone, *Fertil Steril* 78:63, 2002.
282. **Palomba S, Orio F Jr, Morelli M, Russo T, Pellicano M, Nappi C, Mastrantonio P, Lombardi G, Colao A, Zullo F**, Raloxifene administration in women treated with gonadotropin-releasing hormone agonist for uterine leiomyomas: effects on bone metabolism, *J Clin Endocrinol Metab* 87:4476, 2002.
283. **Ripps BA, VanGilder K, Minhas B, Welford M, Mamish Z**, Alendronate for the prevention of bone mineral loss during gonadotropin-releasing hormone agonist therapy, *J Reprod Med* 48:761, 2003.
284. **Felberbaum RE, Germer U, Ludwig M, Riethmüller-Winzen H, Heise S, Buttge I, Bauer O, Reissmann T, Engel J, Diedrich K**, Treatment of uterine fibroids with a slow-release formulation of the

- gonadotropin releasing hormone antagonist Cetrorelix, *Hum Reprod* 13:1660, 1998.
285. **Flierman PA, Oberye JJ, van der Hulst VP, de Blok S**, Rapid reduction of leiomyoma volume during treatment with the GnRH antagonist ganirelix, *Br J Obstet Gynaecol* 112:638, 2005.
  286. **Archer DF, Stewart EA, Jain RI, Feldman RA, Lukes AS, North JD, Soliman AM, Gao J, Ng JW, Chwalisz K**, Elagolix for the management of heavy menstrual bleeding associated with uterine fibroids: results from a phase 2a proof-of-concept study, *Fertil Steril* 108(1):152, 2017. doi:10.1016/j.fertnstert.2017.05.006.
  287. **Eisinger SH, Meldrum S, Fiscella K, le Roux HD, Guzick DS**, Low-dose mifepristone for uterine leiomyomata, *Obstet Gynecol* 101:243, 2003.
  288. **Esteve JLC, Acosta R, Heredia B, Perez Y, Yero Castañeda MC, Hernandez AV**, Mifepristone for the treatment of uterine leiomyomas. A randomized controlled trial, *Obstet Gynecol* 112:1029, 2008.
  289. **Donnez J, Courtoy GE, Donnez O, Dolmans M-M**, Ulipristal acetate for the management of large uterine fibroids associated with heavy bleeding: a review, *Reprod Biomed Online* 37(2):216, 2018.
  290. **Grigorieva V, Chen-Mok M, Tarasova M, Mikhailov A**, Use of a levonorgestrel-releasing intrauterine system to treat bleeding related to uterine leiomyomas, *Fertil Steril* 79:1194, 2003.
  291. **Hurskainen R, Teperi J, Rissanen P, Aalto A-M, Grenman S, Kivelä A, Kujansuu E, Vuorma S, Yliskoski M, Paavonen J**, Clinical outcomes and costs with the levonorgestrel-releasing intrauterine system or hysterectomy for treatment of menorrhagia. Randomized trial 5-year follow-up, *JAMA* 291: 1456, 2004.
  292. **Soysal S, Soysal M**, The efficacy of levonorgestrel-releasing intrauterine device in selected cases of myoma-related menorrhagia: a prospective controlled trial, *Gynecol Obstet Invest* 59:29, 2005.
  293. **Pron G, Bennett J, Common A, Wall J, Asch M, Sniderman K**; for the **Ontario Uterine Fibroid Embolization Collaborative Group**, The Ontario Uterine Fibroid Embolization Trial. Part 2. Uterine fibroid reduction and symptom relief after uterine artery embolization for fibroids, *Fertil Steril* 79:120, 2003.
  294. **Hehenkamp WJ, Volkers NA, Birnie E, Reekers JA, Ankum WM**, Symptomatic uterine fibroids: treatment with uterine artery embolization or hysterectomy—results from the randomized clinical Embolisation versus Hysterectomy (EMMY) Trial, *Radiology* 246:823, 2008.
  295. **Tropeano G, Amoroso S, Scambia G**, Non-surgical management of uterine fibroids, *Hum Reprod Update* 14:259, 2008.
  296. **Goodwin SC, Spies JB, Worthington-Kirsch R, Peterson E, Pron G, Li S, Myers ER**; for the **Fibroid Registry of Outcomes Data (FIBROID) Registry Steering Committee and Core Site Investigators**, Uterine artery embolization for treatment of leiomyomata. Long-term outcomes from the FIBROID registry, *Obstet Gynecol* 111:22, 2008.
  297. **Agdi M, Valenti D, Tulandi T**, Intraabdominal adhesions after uterine artery embolization, *Am J Obstet Gynecol* 199:482, 2008.
  298. **Pron G, Mocarski E, Bennett J, Vilos G, Common A, Vanderburgh L**; the **Ontario Multicenter Trial**, Pregnancy after uterine artery embolization for leiomyomata: the Ontario multicenter trial, *Obstet Gynecol* 105:67, 2005.
  299. **Pabón IP, Magret JP, Unzurrunzaga EA, García IM, Catalán IB, Vieco MLC**, Pregnancy after uterine fibroid embolization: follow-up of 100 patients embolized using tris-acryl gelatin microspheres, *Fertil Steril* 90:2356, 2008.
  300. **Mara M, Maskova J, Fucikova Z, Kuzel D, Belsan T, Sosna O**, Midterm clinical and first reproductive results of a randomized controlled trial comparing uterine fibroid embolization and myomectomy, *Cardiovasc Intervent Radiol* 31:73, 2008.
  301. **Stewart EA, Rabinovici J, Tempany CM, Inbar Y, Regan L, Gostout B, Hesley G, Kim HS, Hengst S, Gedroyc WM**, Clinical outcomes of focused ultrasound surgery for the treatment of uterine fibroids, *Fertil Steril* 85:22, 2006.
  302. **Hesley GK, Gorny KR, Henrichsen TL, Woodrum DA, Brown DL**, A clinical review of focused ultrasound ablation with magnetic resonance guidance: an option for treating uterine fibroids, *Ultrasound Q* 24:131, 2008.
  303. **MRgFUS Study Group; Rabinovici J, David M, Fukunishi H, Morita Y, Gostout BS, Stewart EA**, Pregnancy outcome after magnetic resonance-guided focused ultrasound surgery (MRgFUS) for conservative

treatment of uterine fibroids, *Fertil Steril* 93:199, 2010.

304. **Froeling V, Meckelburg K, Schreiter NF, Scheurig-Muenkler C, Kamp J, Maurer MH, Beck A, Hamm B, Kroencke TJ**, Outcome of uterine artery embolization versus MR-guided high-intensity focused ultrasound treatment for uterine fibroids: long-term results, *Eur J Radiol* 82(12):2265, 2013.
305. **Lichtinger M, Herbert S, Memmolo A**, Temporary, transvaginal occlusion of the uterine arteries: a feasibility and safety study, *J Minim Invasive Gynecol* 12: 40, 2005.

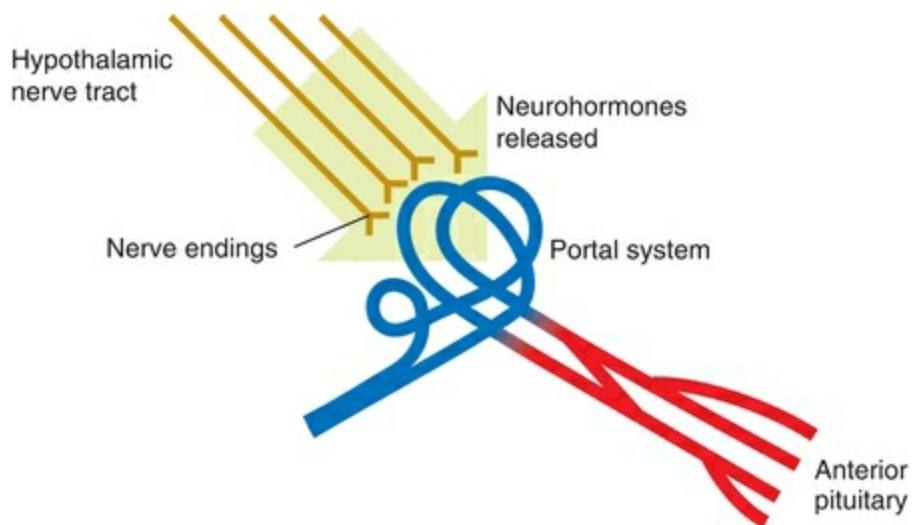
# Neuroendocrinology

There are two major sites of action within the brain that are important in the regulation of reproductive function—the hypothalamus and the pituitary gland. In the past, the anterior pituitary was viewed as the master controller of reproductive biology. Then a new concept emerged in which the pituitary was relegated to a subordinate role as part of an orchestra, with the hypothalamus serving as the conductor, responding on one hand to messages from the peripheral nervous system and central nervous system (CNS), and on the other, exerting its influence on the anterior pituitary by means of neurotransmitters transported directly to the pituitary by a portal vessel network. Regardless of which site was dominant, the conventional view was that the central nervous system-pituitary complex determined and directed the chronology of folliculogenesis and accompanying steroidogenic events within a responsive ovary. It is currently understood that the hypothalamus (acting as a conductor), and under its direction the pituitary and the ovary/ies (each serving as a member of an orchestra), are essential for the complex cascade of events that constitute the menstrual cycle. As is true for successful performance by any orchestra, synchrony between and responsiveness of each member of the reproductive orchestra are critical to normal reproductive function. The complex sequence of events of the menstrual cycle is further controlled by the sex steroids and peptides produced within the very follicle destined to ovulate, and smooth functioning of this machinery is ensured by endocrine feedback exerted by the ovarian hormones on the anterior pituitary.

A full understanding of the mechanisms of reproductive biology will benefit the clinician in understanding and managing common gynecologic disorders that can result from functional abnormalities of the hypothalamo-pituitary-ovarian (HPO) axis. Understanding of the HPO function will allow clinician to better comprehend the hitherto mysterious but significant effects of stress (psychological as well as physical), diet (restriction as well as surplus), and exercise (mostly excess) on regularity of menstrual cycles. To these ends, this chapter offers a clinically oriented review of the current status of reproductive neuroendocrinology.

# HYPOTHALAMIC-HYPOPHYSEAL PORTAL CIRCULATION

The hypothalamus is a precise region at the base of the brain that lies just above the junction of the optic nerves. In order to influence the anterior pituitary gland, the brain requires a means of signal transmission or connection. A direct nervous connection does not exist. The blood supply of the anterior pituitary, however, originates in the capillaries that richly lace the median eminence area of the hypothalamus. The superior hypophyseal arteries form a dense network of capillaries within the median eminence, which then drains into the portal vessels that descend along the pituitary or neural stalk to the anterior pituitary. The direction of the blood flow in this hypophyseal portal circulation is from the hypothalamus to the pituitary. Disruption of the neural stalk, which interrupts this portal circulation and thereby disrupts signals from the brain to the anterior pituitary, therefore leads to a disruption in the normal function of a number of endocrine targets downstream to the hypothalamus, including the gonads, the adrenal, and the thyroid glands. Inactivity and atrophy of the gonads, along with a decrease in adrenal and thyroid activity to basal levels, ensues after section of the neural stalk. Thus, the anterior pituitary gland is under direct influence of the hypothalamus by means of neurohormones which get released into this portal circulation, and after being carried via portal blood to the anterior pituitary, then mediate control of the anterior pituitary hormones. There also exists some retrograde direction to this signaling, so that the anterior pituitary hormones can also be delivered directly to the hypothalamus, creating an opportunity for pituitary hormones to provide feedback on the hypothalamus ([Figure 4.1](#)). An additional blood supply is provided by short vessels that originate in the posterior pituitary that in turn receives its arterial supply from the inferior hypophyseal arteries.





## **FIGURE 4.1**

# THE NEUROHORMONE CONCEPT

---

The hypothalamus exerts a differential control on the functioning of each of the two endocrine compartments of the pituitary gland (i.e., the anterior and the posterior pituitary). The hypothalamus maintains influence on the pituitary through materials that get secreted by the cells of the hypothalamus into the blood stream of the portal circulation; these agents are then transported to their target cells in the anterior pituitary by the portal vessel system. Indeed, pituitary cell proliferation and gene expression are controlled by hypothalamic peptides and their receptors. In addition to the neural stalk section experiments cited previously, transplantation of the anterior pituitary to an ectopic site (e.g., under the kidney capsule) that does not allow the transplanted tissue access to hypothalamic signals results in failure of gonadal function. With retransplantation of the same pituitary tissue to an anatomic site under the median eminence, followed by regeneration of the portal system, normal pituitary function is regained, underscoring a near absolute dependence of the anterior pituitary on hypothalamic signals. Hence, there is something very special about the blood draining the basal hypothalamus. An exception to this overall pattern of positive influence of hypothalamic signals on anterior pituitary function is the control of prolactin secretion by the anterior pituitary cells (lactotropes). Activity of these cells is normally kept under tonic check by hypothalamic inhibitory signals, as an increase in prolactin levels follows experimental disruption of the pituitary stalk. Furthermore, cultures of the anterior pituitary tissue release prolactin in the absence of coculture with hypothalamic tissue or extracts.

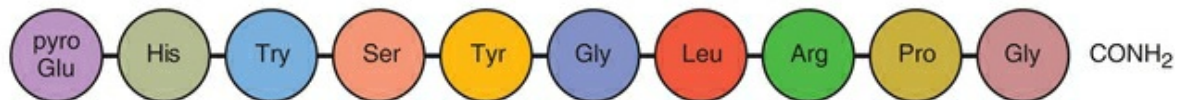
Neuroendocrine factors originating in the hypothalamus are considered as hypothalamic neurohormones and have positive stimulatory effects on a number of anterior pituitary hormones in addition to the gonadotropins (follicle-stimulating hormone [FSH] and luteinizing hormone [LH]), including growth hormone (GH), thyroid-stimulating hormone (TSH), and adrenocorticotrophic hormone (ACTH). The hypothalamic neurohormones are named according to their respective target cell population in the anterior pituitary; for example, hypothalamic signal that controls the function of the anterior pituitary gonadotropic cells (FSH- and LH-producing cells) is called the gonadotropin-releasing hormone (GnRH), whereas the neurohormones that control function of the pituitary adrenocorticotrophic (also called adrenocorticotroph's, cells producing ACTH) and thyrotropic cells (or thyrotrophs cells producing TSH) are, respectively, called CRH (corticotropin-releasing hormone) and TRH (thyrotropin-releasing hormone). The hypothalamic neurohormone that controls prolactin secretion by the pituitary lactotropes is called prolactin-inhibiting hormone but is more commonly recognized as dopamine. Of interest is that the hypothalamic neurohormones may influence function of cells other than their specific target cell. For example, while CRH

is the principal regulator of ACTH secretion, it can also activate the sympathetic nervous system, and as we shall see, hypothalamic CRH can suppress gonadotropin secretion, an action partly mediated by endorphin inhibition of GnRH.

In addition to their effects on the pituitary, behavioral effects within the brain have been demonstrated for several of the releasing hormones. TRH antagonizes the sedative action of a number of drugs and also has a direct antidepressant effect in humans. GnRH evokes mating behavior in male and female animals.<sup>1</sup>

Initially, it was believed that there were two separate gonadotropic-releasing hormones, one for FSH and another for LH. It is now accepted that there is a single neurohormone (GnRH) driver for both gonadotropins. GnRH is a small peptide comprised of 10 amino acids, with some variation in the amino acid sequence among various mammals (**Figure 4.2**). Purified or synthesized GnRH stimulates both FSH and LH secretion. Modulating influences of the endocrine environment, specifically the feedback effects of steroids on the anterior pituitary gland, as well as frequency and amplitude of GnRH release, are recognized to explain the divergent patterns of FSH and LH release from the anterior pituitary in response to a single GnRH neurohormone.

Gonadotropin releasing hormone—  
a decapeptide



**FIGURE 4.2**

The classic neurotransmitters are secreted at the nerve terminal. Brain peptides require gene transcription, translation, and posttranslational processing, all within the neuronal cell body. The final product is transported down the axon to the nerve terminal for secretion. Small neuroendocrine peptides share common large precursor polypeptides, called polyproteins or polyfunctional peptides. These proteins can serve as precursors for more than one biologically active peptide.

The gene that encodes for the 92 amino acid precursor protein for GnRH, pro-GnRH, is located on the short arm of chromosome 8.<sup>2</sup> The precursor protein for GnRH contains (in the following order) a 23 amino acid signal sequence, the GnRH decapeptide, a 3 amino acid proteolytic processing site, and a 56 amino acid sequence called GAP (GnRH-associated peptide).<sup>3</sup> GAP is a potent inhibitor of prolactin secretion as well as a stimulator of gonadotropins; however, a physiologic role for GAP has not been established.<sup>4</sup> Its primary role may be to provide appropriate

conformational support for GnRH.

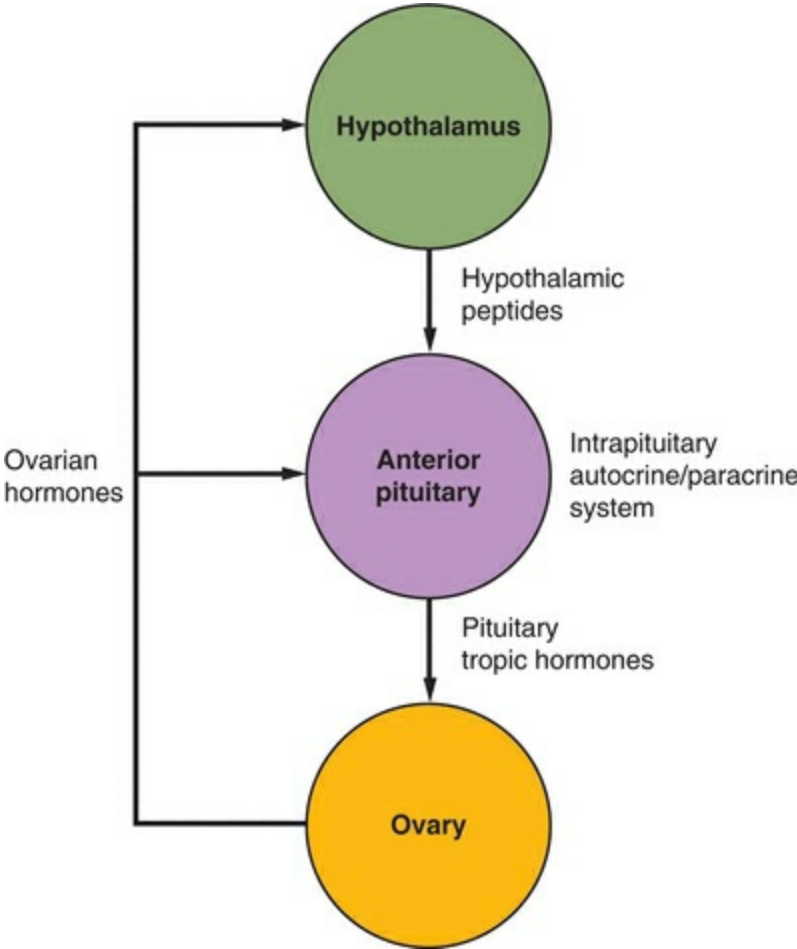
It is now apparent that GnRH has autocrine-paracrine functions throughout the body. It is present in both neural and nonneural tissues, and GnRH receptors are present in many extrapituitary sites (e.g., the ovarian follicle and the placenta). Although the GnRH peptide is identical in all mammals, other nonmammalian forms also exist, indicating that the GnRH molecule has existed for at least 500 million years.<sup>5,6</sup> The central sequence, Tyr-Gly-Leu-Arg, is the nonconserved segment of GnRH, the segment with the most variability across species. Accordingly, substitutions in this fragment of the GnRH neurohormone are well tolerated.

A second form of GnRH, known as GnRH-II, has been known to exist in many other species. GnRH-II consists of the following sequence: pGln-His-Trp-Ser-His-Gly-Trp-Tyr-Pro-Gly. Prompted by its existence in other species, a search for its presence in humans was ultimately successful. A gene encoding GnRH-II is located on the human chromosome 20p13, obviously distinct from the GnRH-I gene on 8p11.2-p21.<sup>7</sup> Similar to GnRH-I, the GnRH-II gene also produces a peptide with a signal sequence, a GnRH decapeptide, a proteolytic site, and a GAP. An analysis of the evolution of GnRH indicates three major forms: GnRH localized to the hypothalamus (GnRH-I), a form in midbrain nuclei and outside the brain (GnRH-II), and yet another variant form that is described in several fish species (GnRH-III), thus indicating appearance of the various forms before the emergence of the vertebrates.<sup>7</sup> In fact, a total of 24 forms of GnRH have been identified in multiple species, but GnRH-I and GnRH-II are the primary GnRH's in mammals.<sup>8</sup> GnRH-I is the main form found in the brain, whereas GnRH-II is widely distributed in other organs with human GnRH-II expression being highest outside the brain.

A hypothalamic 12-amino acid peptide that inhibits pituitary secretion of gonadotropins was isolated from the brain of the Japanese quail.<sup>9</sup> This peptide was identified in mammals as well and labeled as gonadotropin-inhibitory hormone (GnIH), but its presence and possible role/s in primate reproduction remain to be determined.<sup>10</sup>

Despite the aforementioned focus on the hypothalamic signals as drivers of pituitary function, perhaps the notion that the pituitary is a master gland should not be discarded. Although it is highly regulated by input from other sites, its function is essential for sustaining life. The hormones from the pituitary gland regulate puberty, growth, reproduction, metabolism, osmotic balance, and responses to stress. Pituitary development and activity are under the control of the hypothalamus (with input from other CNS sites), and pituitary responses are finely tuned by hormonal messages from tissues that are the targets of the pituitary trophic hormones. In addition, the pituitary has its own autocrine-paracrine system for enhancement and suppression of growth and function. But the pituitary gland is the focus for all of this activity, and this central,

coordinating role executed by the pituitary gland is critical for normal life (Figure 4.3).



**FIGURE 4.3**

# PROLACTIN SECRETION

---

Prolactin gene expression occurs in specialized cells (the lactotrophs) of the anterior pituitary gland, as well as in the decidualized uterine endometrium, and the myometrium. The prolactin hormone secreted in these various anatomical sites is identical, but there are differences in the mRNA indicating differences in prolactin gene regulation.

Transcription of the prolactin gene is regulated by a transcription factor (a protein named Pit-1) that binds to the 5' promoter region and that is also necessary for GH and TSH secretion.<sup>11,12</sup> The expression of Pit-1 is in turn regulated by a transcription factor, Prop1 (Prophet of Pit-1); mutations in the Prop1 binding site in the Pit-1 gene result in deficiencies in multiple pituitary hormones.<sup>12,13</sup> These mutations account for the majority of inherited cases of combined pituitary hormone deficiency. The remainder arise from mutations involving other transcription factors, specifically HESX1, LHX3, LHX4, TBX19, SOX2, and SOX3.<sup>14</sup>

Prolactin gene transcription is regulated by the interaction of estrogen and glucocorticoid receptors with 5' flanking sequences. Mutations in the sequences of these flanking regions or in the gene for the Pit-1 protein can result in a failure to secrete prolactin. The Pit-1 gene is also involved in differentiation and growth of anterior pituitary cells; therefore, mutations in this gene can lead not only to absent secretion of prolactin but also of GH, and TSH, resulting from an absence of their respective tropic cells in the pituitary—the result is significant hypopituitarism.<sup>15</sup> Molecular studies indicate that Pit-1 participates in mediating both stimulatory and inhibitory hormone signals for prolactin gene transcription. However, alterations in Pit-1 gene expression are not involved in pituitary tumor formation.<sup>16</sup>

The main function of the hormone prolactin in mammals is lactogenesis, whereas, in the fish, prolactin is important for osmoregulation. The prolactin gene from the Chinook salmon contains coding sequences that are similar to those in mammals, and it is regulated similarly in the pituitary.<sup>17</sup> Pit-1, the pituitary-specific transcription factor, therefore, appears to be highly conserved among species. Sexual arousal and orgasm in men and women produce marked elevations of circulating levels of prolactin that persist for at least 1 hour, perhaps contributing to the suppression of sexuality immediately after arousal and orgasm.<sup>18,19</sup>

Prolactin gene expression is further regulated by other species-specific factors. Prolactin gene transcription is stimulated by estrogen and mediated by estrogen receptor binding to estrogen-responsive elements. This activation by estrogen requires interaction with Pit-1, in a manner not yet determined. Proximal promoter sequences are

also activated by peptide hormones binding to cell surface receptors, for example, TRH and growth factors. In addition, various agents that control cyclic AMP and calcium channels can stimulate or inhibit prolactin promoter activity.

Pituitary secretion of prolactin is chiefly, if not totally, under the inhibitory control of hypothalamic dopamine released into the portal circulation, a tonic inhibition that requires a high output of dopamine.<sup>20</sup> The action of dopamine in the pituitary is mediated by receptors that are coupled to the inhibition of adenylate cyclase activity. There are five forms of the dopamine receptors, divided into two functional groups. Two of the dopamine receptors, D<sub>1</sub> and D<sub>2</sub>, are encoded by a single gene on chromosome 5, located near the GH receptor gene.<sup>21,22</sup> The D<sub>2</sub> type is the predominant dopamine receptor in the anterior pituitary gland. The structure and function of the dopamine receptors are of the G protein system described in [Chapter 1](#). Binding of dopamine to its receptor leads to suppression of adenylate cyclase and cyclic AMP maintenance of prolactin gene transcription and prolactin secretion. Other mechanisms are also activated, including suppression of intracellular calcium levels. Pit-1-binding sites are involved in this dopamine response. In addition to direct inhibition of prolactin gene expression, dopamine binding to the D<sub>2</sub> receptor also inhibits lactotrope development and growth. These multiple effects of dopamine explain the ability of dopamine agonists to suppress prolactin secretion and the growth of prolactin-secreting pituitary adenomas. No activating or inactivating mutations of the dopamine receptors have been reported.

Several factors exert a stimulatory effect on prolactin secretion (prolactin-releasing factors), especially TRH, vasoactive intestinal peptide (VIP), epidermal growth factor, and perhaps GnRH. These factors also interact with each other, affecting the overall lactotroph responsiveness; however, the only important clinical manifestation is the association of hyperprolactinemia with the elevation in TRH secretion that occurs with primary hypothyroidism. **Prolactin homeostasis is regulated mainly by prolactin itself, feeding back on the dopamine-releasing neurons.**

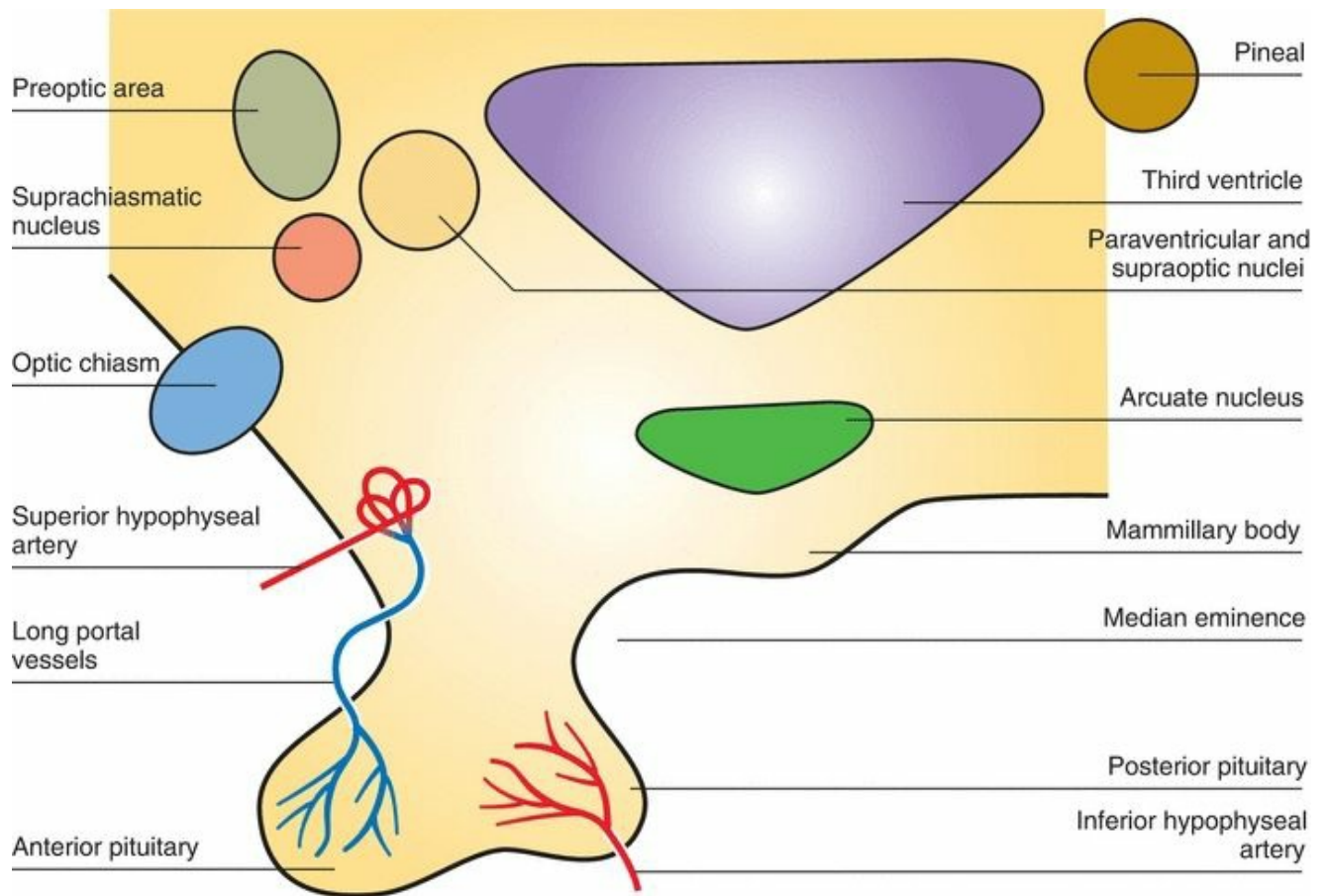
This dopaminergic mechanism is highly influenced by estrogen, either directly or through other neurotransmitters. Prolactin secretion can be understood by viewing dopamine received through the hypothalamo-pituitary portal system as responsible for its tonic inhibition. The dopaminergic system is itself stimulated by prolactin (prolactin thus decreasing its own secretion) and inhibited by estrogen (with estrogen increasing secretion of prolactin). Modulating influences on the dopaminergic axis include inhibitory influences of endogenous opioids on dopamine release (thereby resulting in an increase in prolactin secretion) and stimulation by other substances, including serotonin and neuropeptide Y (with resulting decrease in prolactin). Prolactin levels are highest during sleep.

Drugs used to treat psychological disorders are dopamine receptor antagonists. The inhibitory activity of dopamine on pituitary secretion of prolactin is blocked by these drugs, and prolactin levels increase in the circulation. Some of the newer drugs in this class do not affect prolactin secretion; these include clozapine, olanzapine, quetiapine, aripiprazole, and ziprasidone. Risperidone and amisulpride, however, act like the older drugs and increase prolactin secretion. The differences reflect the ability of each drug to cross the blood-brain barrier and the variations in affinity for the dopamine receptor.



# THE HYPOTHALAMUS AND GNRH SECRETION

The hypothalamus is the part of the diencephalon at the base of the brain that forms the floor of the third ventricle and part of its lateral walls (**Figure 4.4**). Within the hypothalamus are peptidergic neurohormone secreting neural cells that secrete the earlier described releasing and inhibiting hormones. These cells share the characteristics of both neurons and endocrine gland cells, and hence the name neuroendocrine. They respond to signals in the bloodstream, as well as to neurotransmitters within the brain, by a process known as neurosecretion. In response to appropriate signals, a neurohormone or neurotransmitter gets synthesized by the ribosomes in the cytoplasm of the neuroendocrine cell, is then packaged into a granule in the cellular Golgi apparatus, and then transported by active axonal flow to the neuronal cell terminal for secretion into a blood vessel or across a synapse.



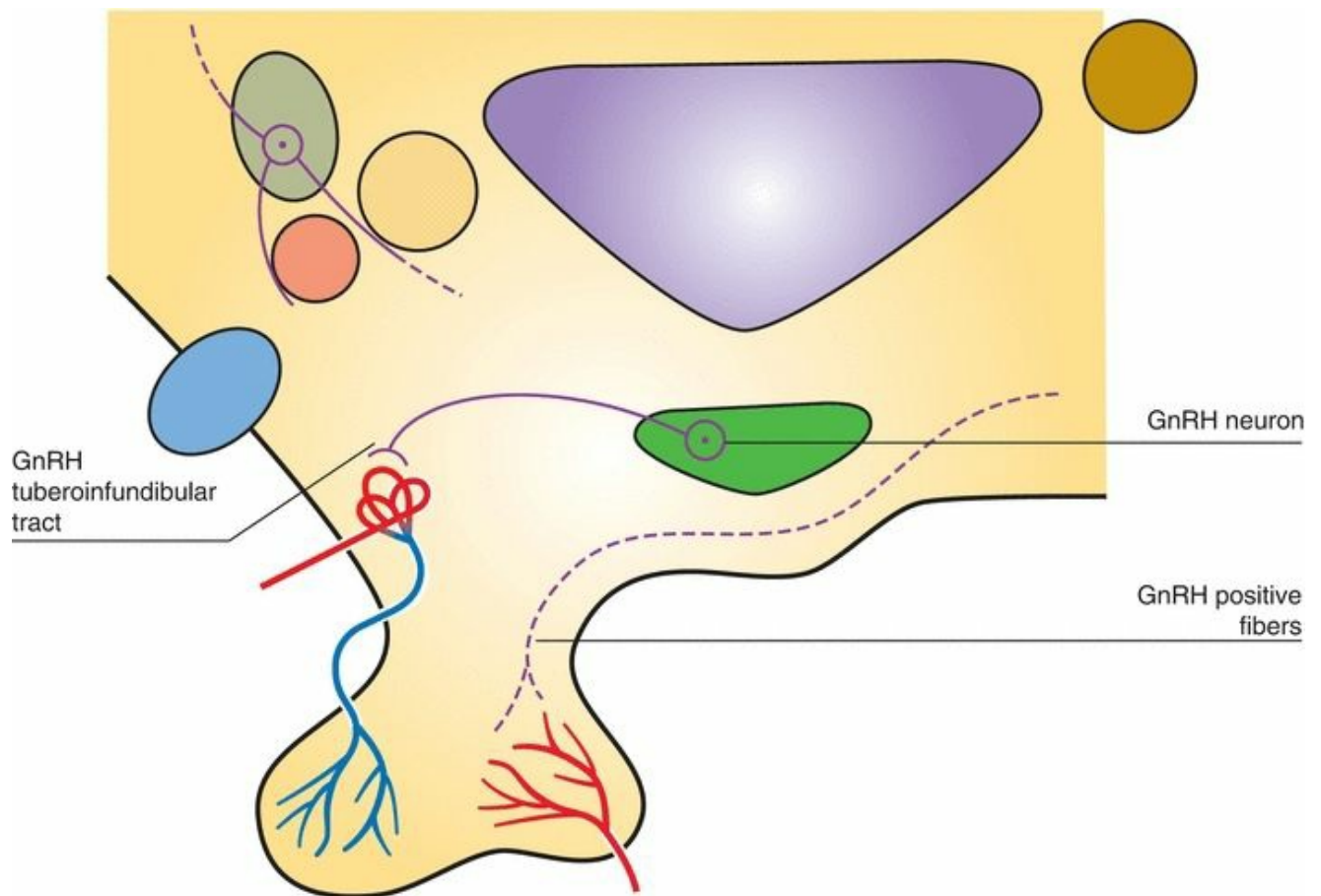
**FIGURE 4.4**

The neuroendocrine cells that produce GnRH originate from the olfactory area or the developing brain. By migration during embryogenesis, these cells move along cranial nerves connecting the nose and the forebrain to their final location, where eventually 1,000–3,000 GnRH-producing cells can be found in the arcuate nucleus of the hypothalamus extending their axons to the median eminence.<sup>23</sup> The GnRH neurons appear in the medial olfactory placode (a thickened plate of ectoderm from which a sense organ develops) and enter the brain with the nervus terminalis, a cranial nerve that projects from the nose to the septal-preoptic nuclei in the brain.<sup>24</sup> Disturbances in this amazing journey characterize the clinical entity Kallmann syndrome; a failure of both olfactory axonal and GnRH neuronal migration from the olfactory placode results in the absence of GnRH as well as defects in the sense of smell that are characteristic of Kallmann syndrome. Three modes of transmission have been documented for Kallmann syndrome: X-linked, autosomal-dominant, and autosomal-recessive.<sup>25</sup> The 5–7-fold increased frequency in the males indicates that X-linked transmission is the most common genetic variant of this disorder. The mutations responsible for this syndrome result in a failure to produce proteins with functions that are necessary for neuronal migration, such as anosmin-1, a protein that is homologous to members of the fibronectin family and responsible for cell adhesion and protease inhibition (in X-linked variants of the syndrome), and receptors for fibroblast growth factor and prokineticin (in autosomal forms of the syndrome).<sup>26,27,28</sup> Normal GnRH neuron development and migration also depend on receptors that are tyrosine kinases, and abnormalities in these receptors might explain some clinical cases of GnRH deficiency.<sup>29</sup>

Like olfactory epithelial cells in the nasal cavity, GnRH neurons have cilia.<sup>30</sup> The olfactory origin and the structural similarity of GnRH neurons and nasal epithelial cells suggest an evolution from reproduction controlled by pheromones. Pheromones are airborne chemicals released by one individual that can affect other members of the same species. Odorless compounds obtained from the axillae of women in the late follicular phase of menstrual cycles accelerated the LH surge and shortened the cycles of recipient women, and compounds from the luteal phase had the opposite effects.<sup>31</sup> This may be one mechanism by which women who are together much of the time have been reported to exhibit a synchrony in menstrual cycle timing.<sup>32,33,34,35,36</sup> However, the work on menstrual synchrony has been criticized, emphasizing that methodologic problems have led to incorrect conclusions.<sup>37</sup>

In primates, GnRH cell bodies are primarily located within the medial basal hypothalamus.<sup>38,39,40</sup> Most of these cell bodies can be seen within the arcuate nucleus where GnRH is synthesized in GnRH neurons. The GnRH neurons exist in a complex network and are connected to each other and to many other neurons. This physical

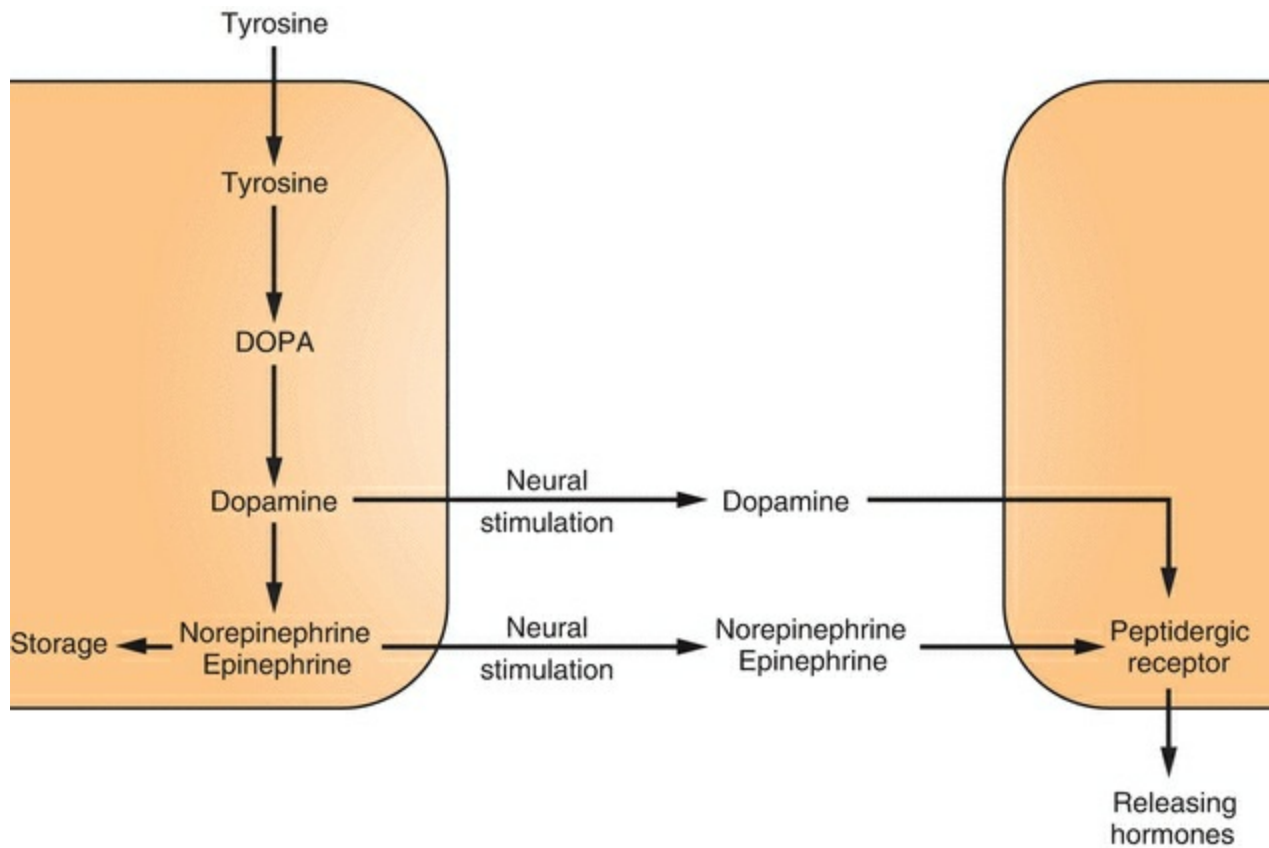
arrangement allows multiple interactions with neurotransmitters, hormones, and growth factors to modulate GnRH release. The delivery of the neural secreted GnRH to the portal circulation is via an axonal pathway, the GnRH tuberoinfundibular tract. Nerve fibers, identified with immunocytochemical techniques using antibodies to GnRH, can also be visualized in the posterior hypothalamus, descending into the posterior pituitary, and in the anterior hypothalamic area projecting to sites within the limbic system (Figure 4.5).<sup>38</sup> Using hybridization techniques, messenger RNA for GnRH has been localized to the same sites previously identified by immunoreactivity. However, lesions that interrupt GnRH neurons projecting to regions other than the median eminence do not affect pituitary gonadotropin release. Only lesions of the arcuate nucleus in the monkey lead to gonadal atrophy and amenorrhea consequent to loss of gonadotropin signal.<sup>41</sup> **Therefore, the arcuate nucleus can be viewed with the median eminence as a unit, the key locus within the hypothalamus for GnRH secretion into the portal circulation.** GnRH neurons in other locations may be important for a variety of behavioral responses.



**FIGURE 4.5**

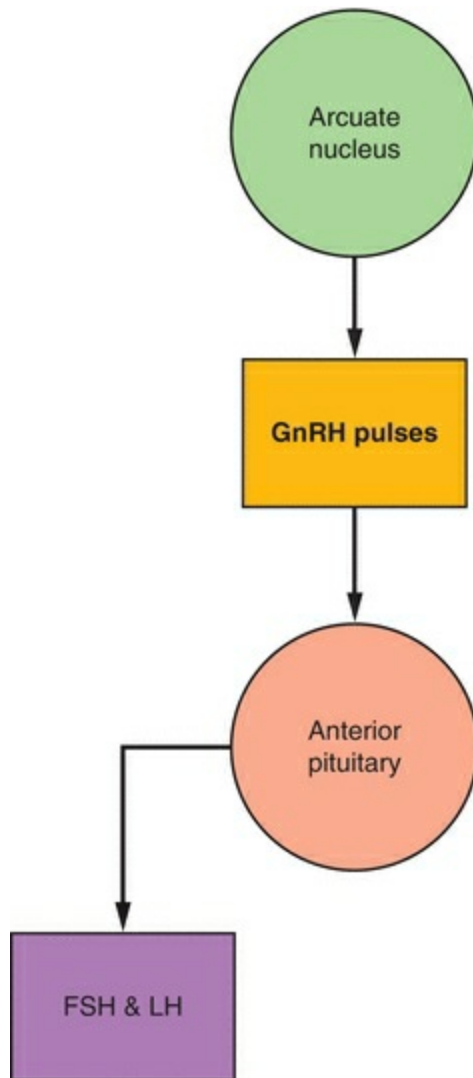
# GnRH Secretion

The half-life of GnRH is only 2–4 minutes. Because of this rapid degradation, combined with the enormous dilution on entry into the peripheral circulation, biologically effective amounts of GnRH do not escape the hypophyseal portal system. Therefore, control of the reproductive cycle depends on constant release of GnRH, which in turn results from complex and coordinated interrelationships among this releasing hormone, other neurohormones, the pituitary gonadotropins, and the gonadal steroids. The interplay among these substances is governed by feedback effects, both positive stimulatory and negative inhibitory. **The long feedback loop** refers to the feedback effects of circulating levels of target gland hormones, and this occurs both in the hypothalamus and the pituitary. **The short feedback loop** indicates a negative feedback of pituitary hormones on their own secretion, presumably via inhibitory effects on releasing hormones in the hypothalamus. **Ultrashort feedback** refers to inhibition by the releasing hormone on its own synthesis. These signals as well as signals from higher centers in the CNS may modify GnRH secretion through an array of neurotransmitters, primarily dopamine, norepinephrine, and endorphin but also serotonin and melatonin. Dopamine and norepinephrine are synthesized in the nerve terminals by decarboxylation of dihydroxyphenylalanine (DOPA), which in turn is synthesized by hydroxylation of tyrosine. Dopamine is the immediate precursor of norepinephrine and epinephrine, but dopamine itself functions as a key neurotransmitter in the hypothalamus and the pituitary (**Figure 4.6**).<sup>20</sup>



**FIGURE 4.6**

**A most useful concept is to view the arcuate nucleus as the central site of action, releasing GnRH into the portal circulation in pulsatile fashion.** In a classic series of experiments, it was demonstrated that normal gonadotropin secretion by the pituitary gonadotrophs requires pulsatile GnRH discharge within a critical range in both frequency and amplitude (Figure 4.7).<sup>42,43</sup>



**FIGURE 4.7**

Experimental manipulations have indicated that the critical range of GnRH pulsatile secretion is rather narrow. The administration (to monkeys) of 1  $\mu\text{g}$  GnRH per minute for 6 minutes every hour (one pulse per hour) produces a portal blood concentration about equal to the peak concentration of GnRH in human portal blood, about 2 ng/mL. Increasing the frequency to two and five pulses per hour extinguishes gonadotropin secretion. A similar decline in gonadotropin secretion is obtained by increasing the dose of GnRH. Decreasing the pulse frequency decreases LH secretion but increases FSH secretion.

Like GnRH, gonadotropins are also secreted in pulsatile fashion, and, indeed, the pulsatile pattern of gonadotropin release reflects the pulsatile GnRH pattern.<sup>44,45</sup> GnRH and gonadotropin secretion are always pulsatile in nature, but an augmentation of the pulsatile pattern of gonadotropin secretion occurs just before puberty with nighttime increases in LH. In puberty, arcuate activity begins with a low frequency of GnRH

release and proceeds through a cycle of acceleration of frequency, characterized by passage from relative inactivity, to nocturnal activation, to the full adult pattern. The progressive changes in FSH and LH reflect this activation of GnRH pulsatile secretion. After puberty, enhanced pulsatile secretion is maintained throughout the 24-hour period, but it varies in both amplitude and frequency. Ovarian steroid release is also pulsatile, coordinated with LH pulses, the major stimulator of ovarian steroidogenesis.<sup>46</sup> In the absence of ovarian regulation, the GnRH pulse frequency is approximately one pulse per hour.<sup>47</sup>

# Timing of GnRH Pulses

The measurement of LH pulses is used as an indication of GnRH pulsatile secretion (the long half-life of FSH precludes its use for this purpose).<sup>48</sup> The characteristics of LH pulses (and presumably of GnRH pulses) during the menstrual cycle are as follows<sup>46,49,50</sup>:

- **LH pulse mean amplitude:**
  - Early follicular phase 6.5 IU/L
  - Midfollicular phase 5.0 IU/L
  - Late follicular phase 7.2 IU/L
  - Early luteal phase 15.0 IU/L
  - Midluteal phase 12.2 IU/L
  - Late luteal phase 8.0 IU/L
- **LH pulse mean frequency:**
  - Early follicular phase 90 minutes
  - Late follicular phase 60–70 minutes
  - Early luteal phase 100 minutes
  - Late luteal phase 200 minutes

The follicular phase of the menstrual cycle is characterized by a higher frequency and lower amplitude of GnRH pulses compared to the luteal phase. The slowing of GnRH pulse frequencies in the late luteal phase is an important change, favoring FSH synthesis and secretion over that of LH; this transition in GnRH pulse characteristics allows the rise in FSH that is essential for the next cycle.<sup>51</sup> An increase in frequency and amplitude in mid-cycle GnRH pulsatile secretion favors the surge of LH that is necessary for ovulation and the beginning of the luteal phase.

It should be emphasized that these numbers are not inviolate. There is considerable variability between and within individuals, and a wide normal range exists.<sup>52</sup> Despite the handicap of the long half-life, it has been ascertained that FSH secretion is correlated with LH secretion. The changes in amplitude are relatively small; therefore, increasing and decreasing circulating levels of the gonadotropins are affected mostly by changes in GnRH pulse frequency. During the luteal-follicular transition, pulse frequency increases approximately 4.5-fold.<sup>50</sup> In rodents, the frequency of GnRH pulses determines which gonadotropin subunit gene will be preferentially expressed.<sup>53</sup>

The anterior pituitary gland and GnRH neurons have an intrinsic pulsatile pattern. Although gonadotropin pulses of significant amplitude are linked to released GnRH, small-amplitude pulses of high frequency represent spontaneous secretion from the



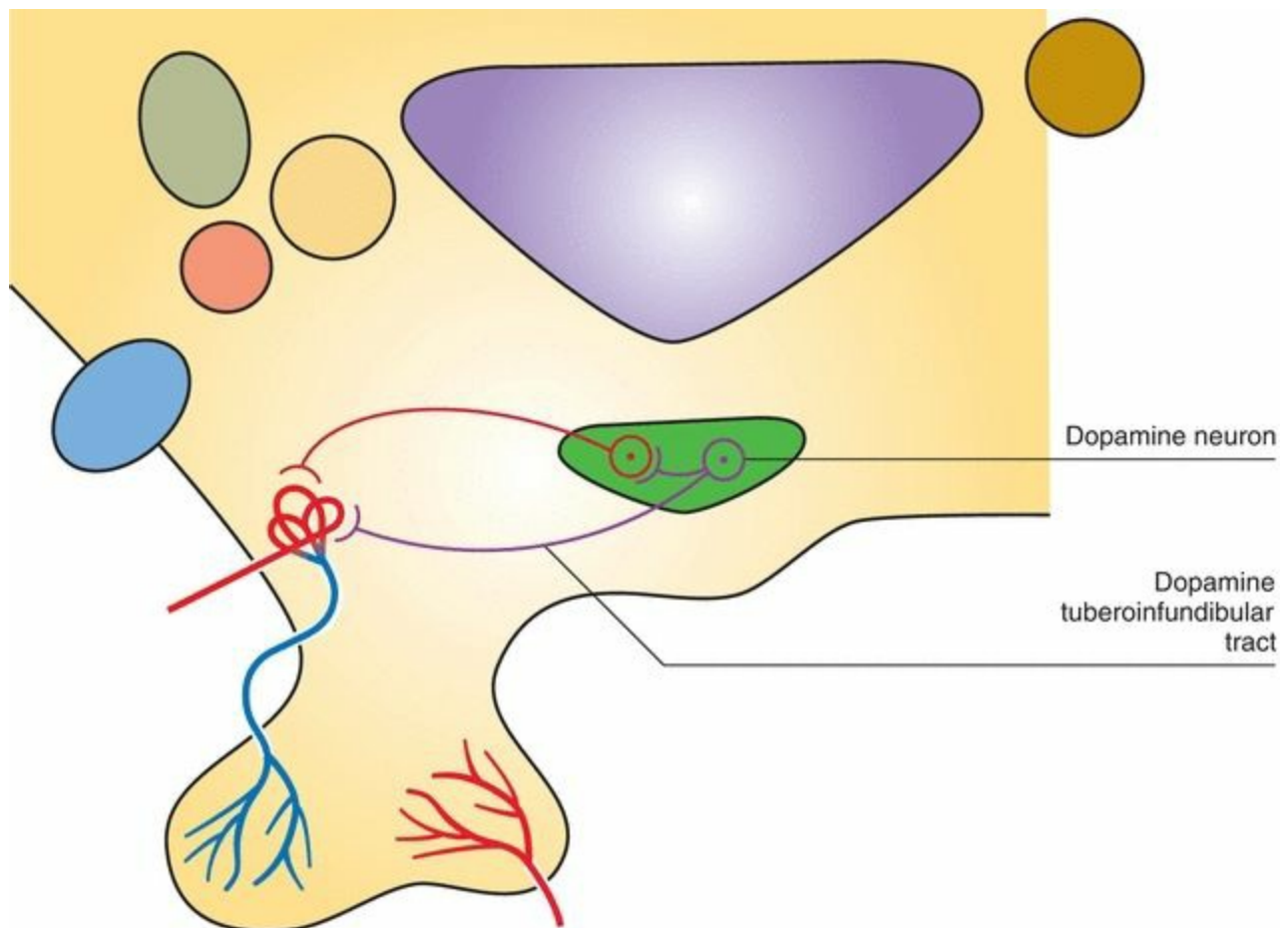
anterior pituitary (at least as demonstrated in isolated pituitary glands in vitro).<sup>54</sup> It is not known whether this has any importance physiologically, and, at the present time, the pituitary secretory pattern is thought to reflect GnRH. The pulsatile secretion of GnRH correlates with episodic GnRH-I gene expression in the hypothalamus.<sup>8</sup> A promoter site in the GnRH-I gene is responsible for the pulsatile nature of the secretions, regulated by the usual array of transcription factors.<sup>55</sup>

# Control of GnRH Pulses

Normal menstrual cycles require the maintenance of the pulsatile release of GnRH within a critical range of frequency and amplitude. Pulsatile, rhythmic activity is an intrinsic property of GnRH neurons, and the effect of various hormones and neurotransmitters must be viewed as modulating actions.<sup>56</sup>

## The Dopamine Tract

Cell bodies for dopamine-producing neurons can be found in the arcuate and periventricular nuclei (Figure 4.8). The dopamine tuberoinfundibular tract arises within the medial basal hypothalamus and its short axons terminate in the median eminence; it provides the major dopaminergic effect on the pituitary.



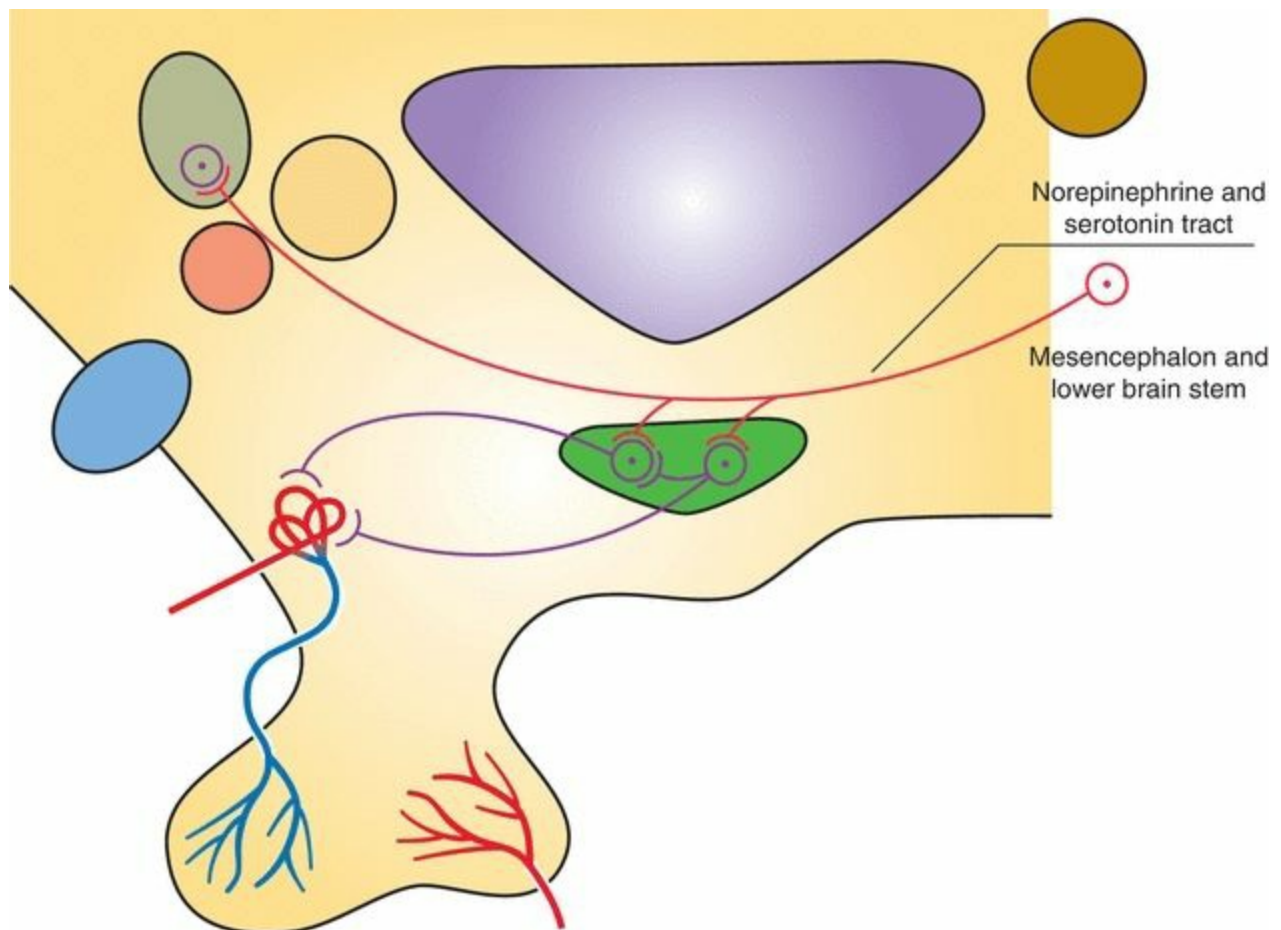
**FIGURE 4.8**

Administration of dopamine by intravenous infusion to men and women is associated with a suppression of circulating prolactin and gonadotropin levels.<sup>57</sup> Dopamine,

however, does not exert a direct effect on gonadotropin secretion by the anterior pituitary, but this effect is mediated through alteration in GnRH release in the hypothalamus. Dopamine is directly secreted into the portal blood, thus behaving like a neurohormone. Therefore, dopamine may directly suppress arcuate GnRH activity and also be transported via the portal system to directly and specifically suppress pituitary prolactin secretion. The hypothalamic tuberoinfundibular dopamine pathway is only one of two major dopamine pathways in the hypothalamus. But it is this pathway that directly participates in the regulation of prolactin secretion. In addition, prolactin delivered to the intermediate lobe of the pituitary suppresses melanocyte-stimulating hormone (MSH) release.

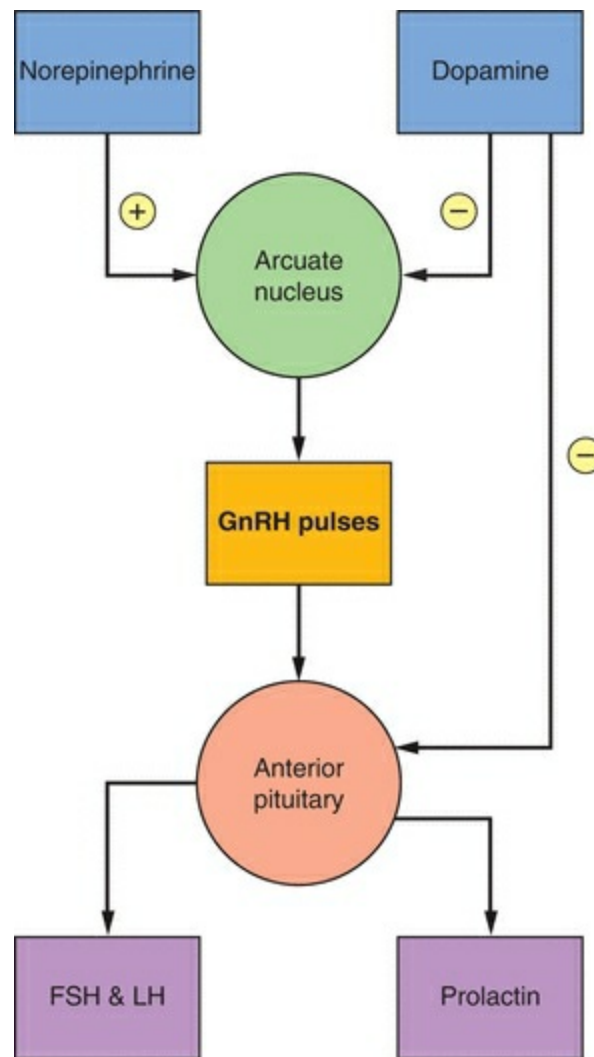
## The Norepinephrine Tract

Most of the cell bodies that synthesize norepinephrine are located in the mesencephalon and lower brainstem (**Figure 4.9**). These cells also synthesize serotonin. Axons for amine transport ascend into the medial forebrain bundle to terminate in various brain structures including the hypothalamus.



**FIGURE 4.9**

The biogenic catecholamines modulate GnRH pulsatile release (Figure 4.10).<sup>58</sup> Norepinephrine is thought to exert stimulatory effects on GnRH, whereas dopamine and serotonin exert inhibitory effects. For an understanding of clinical problems, it is best to view dopamine as an inhibitor of both GnRH and prolactin. Little is known, however, about the role of serotonin. The probable mode of action of catecholamines is to influence the frequency (and perhaps the amplitude) of GnRH discharge. Thus, pharmacologic or psychologic factors that affect pituitary function probably do so by altering catecholamine synthesis or metabolism and, thus, the pulsatile release of GnRH.



**FIGURE 4.10**

## Neuropeptide Y

Neuropeptide Y is an important peptide in the mechanism by which leptin and insulin inform the hypothalamus about the nutritional state of an individual. The secretion and

gene expression of neuropeptide Y in hypothalamic neurons are regulated by gonadal steroids.<sup>59</sup> Neuropeptide Y stimulates appetite and the pulsatile release of GnRH; in the pituitary, it potentiates gonadotropin response to GnRH.<sup>60</sup> It, thus, may facilitate pulsatile secretion of GnRH and gonadotropins. In the absence of estrogen, neuropeptide Y inhibits gonadotropin secretion. Because undernutrition is associated with an increase in neuropeptide Y (see [Chapter 19](#)) and increased amounts have been measured in cerebrospinal fluid (CSF) of women with anorexia and bulimia nervosa, neuropeptide Y is viewed as at least one link between nutrition and reproductive function.<sup>61,62</sup> The level of the neuroendocrine activity involved in reproduction is sensitive to an individual's energy state, or more simply, to the availability of sufficient body fuel to support reproduction.

## **Kisspeptins**

Kisspeptins are peptides encoded by the gene *Kiss1* that is expressed in the hypothalamus. Kisspeptin and its G-protein receptor, GPR54, are essential for the normal pubertal development.<sup>63</sup> This signaling pathway is involved in the activation of GnRH neurons and GnRH secretion.<sup>64,65</sup> The kisspeptin neurons contain estrogen and progesterone receptors and are involved not only in puberty but in the changes associated with ovulatory cycles, in at least one pathway by which the sex steroids affect GnRH secretion.

# PITUITARY GONADOTROPIN SECRETION

---

The gene for the alpha ( $\alpha$ ) subunit of the gonadotropins is expressed in both the pituitary and placenta. The  $\beta$  subunit for human chorionic gonadotropin (hCG) is expressed in the placenta but only minimally (and with alterations in structure) in the pituitary, whereas the LH  $\beta$  subunit, as expected, is expressed in the pituitary but not significantly in the placenta.<sup>66,67</sup> Studies of gonadotropin gene expression confirm the relationships established by earlier studies. The sex steroids decrease and castration increases the rate of gonadotropin gene transcription as reflected by the levels of specific messenger RNAs. In addition, the sex steroids can act at the membrane level, affecting the interaction of GnRH with its receptor.<sup>68</sup>

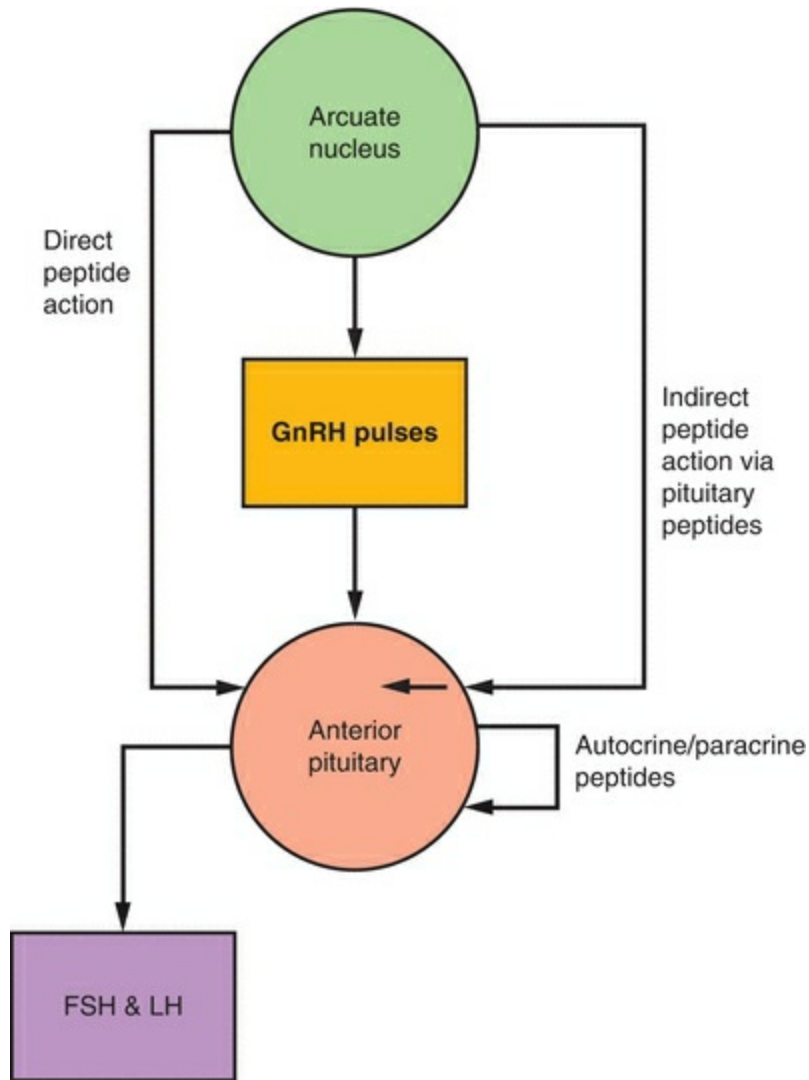
Both LH and FSH are secreted by the same cell, the gonadotrope, localized primarily in the lateral portions of the pituitary gland, and responsive to the pulsatile stimulation by GnRH. GnRH is calcium dependent in its mechanism of action and utilizes inositol 1,4,5-triphosphate ( $IP_3$ ) and 1,2-diacylglycerol (1,2-DG) as second messengers to stimulate protein kinase and cyclic AMP activity (Chapter 2).<sup>69</sup> These responses require a G protein receptor and are associated with cyclical release of calcium ions from intracellular stores and the opening of cell membrane channels to allow entry of extracellular calcium. Thus, calmodulin (a calcium-binding protein), protein kinase, and cyclic AMP are all downstream mediators of GnRH action. Within the gonadotropin secreting cells, gene transcription is mediated by several transcription factors, providing a mechanism by which the various subunits of FSH and LH can be synthesized and secreted by the same cell.<sup>70</sup> The rate-limiting step for the secretion of FSH and LH is the synthesis of the  $\beta$ -subunits of each gonadotropin.

The GnRH type I receptor, a member of the G protein family, is encoded by a gene on chromosome 14q13.1-q21.1.<sup>71,72</sup> The location of the type II receptor is uncertain; in the marmoset, it is on chromosome 1q.<sup>73</sup> The exact roles of the two GnRHs and GnRH receptors in the human are yet to be determined. GnRH receptors are regulated by many agents, including GnRH itself, peptides inhibin and activin, and the sex steroids.<sup>74</sup> The number of GnRH receptors available is significantly regulated by the frequency of GnRH pulses. The signaling pathways include the induction and modification of stimulatory and inhibitory transcription factor proteins. No mutations in the GnRH gene have been described in patients with hypogonadotropic hypogonadism; however, multiple mutations in the GnRH receptor gene have been reported.

Synthesis of gonadotropins takes place on the rough endoplasmic reticulum. The hormones are packaged into secretory granules by the Golgi cisternae of the Golgi apparatus and then stored as secretory granules. Secretion requires migration (activation) of the mature secretory granules to the cell membrane where an alteration in

membrane permeability results in extrusion of the secretory granules in response to GnRH. The rate-limiting step in gonadotropin synthesis is the GnRH-dependent availability of the  $\beta$  subunits.

Binding of GnRH to its receptor in the pituitary activates multiple messengers and responses. The immediate event is a secretory release of gonadotropins, whereas delayed responses prepare for the next secretory release. One of these delayed responses is the self-priming action of GnRH that leads to even greater responses to subsequent GnRH pulses due to a complex series of biochemical and biophysical intracellular events. This self-priming action is important to achieve the large surge in gonadotropin secretion at midcycle; it requires estrogen exposure, and it can be augmented by progesterone. This important action of progesterone depends on estrogen exposure (that results in an increase in the expression of progesterone receptors) and activation of the progesterone receptor by GnRH-stimulated phosphorylation. This latter action is an example of cross-talk between peptide and steroid hormone receptors (**Figure 4.11**).



**FIGURE 4.11**

Five different types of secretory cells coexist within the anterior pituitary gland: gonadotropes (secrete gonadotropins FSH and LH), lactotropes (secrete prolactin), thyrotropes (secrete TSH), somatotropes (GH secreting cells), and corticotropes (ACTH secreting cells). Autocrine and paracrine interactions combine to make anterior pituitary secretion subject to more complicated control than simply reaction to hypothalamic-releasing factors and modulation by feedback signals. Substantial experimental evidence exists to indicate stimulatory and inhibitory influences of various substances on the pituitary secretory cells. Although the GnRH system is a primary mechanism, other hypothalamic peptides can influence gonadotropin secretion by the pituitary gonadotropes. Peptides can interact with GnRH at the pituitary; peptides can be transported to the pituitary gland where they can directly affect the gonadotropes (e.g., oxytocin, CRH, and neuropeptide Y) or indirectly have an effect on FSH and LH secretion by stimulating release of active substances within the pituitary (e.g., galanin,



interleukins).

# THE INTRAPITUITARY AUTOCRINE-PARACRINE SYSTEM

---

Intrapituitary cytokines and growth factors provide an autocrine-paracrine system for regulating pituitary cell development and replication, as well as influence pituitary hormone synthesis and secretion. The pituitary contains the familiar cast of substances encountered in organs throughout the body, including the interleukins, epidermal growth factor, fibroblast growth factors, insulin-like growth factors, nerve growth factor, activin, inhibin, endothelin, and many others.<sup>75,76,77</sup> As in most tissues, the interaction among these substances is a complex story, but the activin-inhibin mechanism deserves emphasis.

# Activin, Inhibin, and Follistatin

Activin and inhibin are peptide members of the transforming growth factor-beta ( $\beta$ ) family.<sup>78</sup> Inhibin consists of two dissimilar peptides ( $\alpha$  and  $\beta$  subunits) linked by disulfide bonds. Two forms of inhibin (inhibin-A and inhibin-B) have been purified, each containing an identical  $\alpha$  subunit and distinct but related  $\beta$  subunits. Thus, there are three subunits for inhibins: alpha, beta-A, and beta-B. Each subunit is a product of different messenger RNA; therefore, each is derived from its own large precursor molecule.

Inhibin is secreted by the ovarian granulosa cells, but messenger RNA for the  $\alpha$  and  $\beta$  chains has also been found in pituitary gonadotropes.<sup>79</sup> Inhibin selectively inhibits FSH but not LH secretion. Indeed, while suppressing FSH synthesis, inhibin may enhance LH activity.<sup>80,81</sup> Cells actively synthesizing LH respond to inhibin by increasing GnRH receptor number; FSH dominant cells are suppressed by inhibin.<sup>80</sup> Inhibin has little or no effect on GH, ACTH, or prolactin production. The mechanism of FSH inhibition may be secondary to inhibin competing with activin for the activin receptor.

Activin, also derived from ovarian granulosa cells, but present as well in the pituitary gonadotropes, contains two subunits that are identical to the  $\beta$  subunits of inhibins A and B. In addition, activins have been identified with variants of the  $\beta$  subunits, designated as beta-C, beta-D, and beta-E.<sup>82</sup> The activin beta-C and beta-E genes have been demonstrated to be nonessential in mouse knockout models.<sup>83</sup> Activin augments the secretion of FSH and inhibits prolactin, ACTH, and GH responses.<sup>81,84,85,86</sup> Activin increases pituitary response to GnRH by enhancing GnRH receptor formation.<sup>74,87</sup> The effects of activin are blocked by inhibin and follistatin.<sup>88</sup> The roles for inhibin and activin in regulating the events of the menstrual cycle are discussed in [Chapter 5](#). In contrast to inhibin's major role in suppressing FSH secretion, activin has a broad range of activities, involving bone, neurons, wound healing, and autocrine-paracrine functions in many organs ([Table 4.1](#)).

## TABLE 4.1 Forms of Inhibin and Activin

**Forms of Inhibin****Inhibin**

Inhibin-A

Alpha-BetaA

Inhibin-B

Alpha-BetaB

**Forms of Activin****Activin**

Activin-A

BetaA-BetaA

Activin-AB

BetaA-BetaB

Activin-B

BetaB-BetaB

Activin-C

BetaC-BetaC

Activin-AC

BetaA-BetaC

Activin-E

BetaE-BetaE

Follistatin is a peptide secreted by a variety of pituitary cells, including the gonadotropes.<sup>89</sup> This peptide has also been called FSH-suppressing protein because of its main action: inhibition of FSH synthesis and secretion and the FSH response to GnRH, by binding to activin and in that fashion decreasing the activity of activin.<sup>90,91</sup> Activin in turn stimulates follistatin production, and inhibin prevents this response.

# **SUMMARY: CONTROL OF GONADOTROPIN SECRETION**

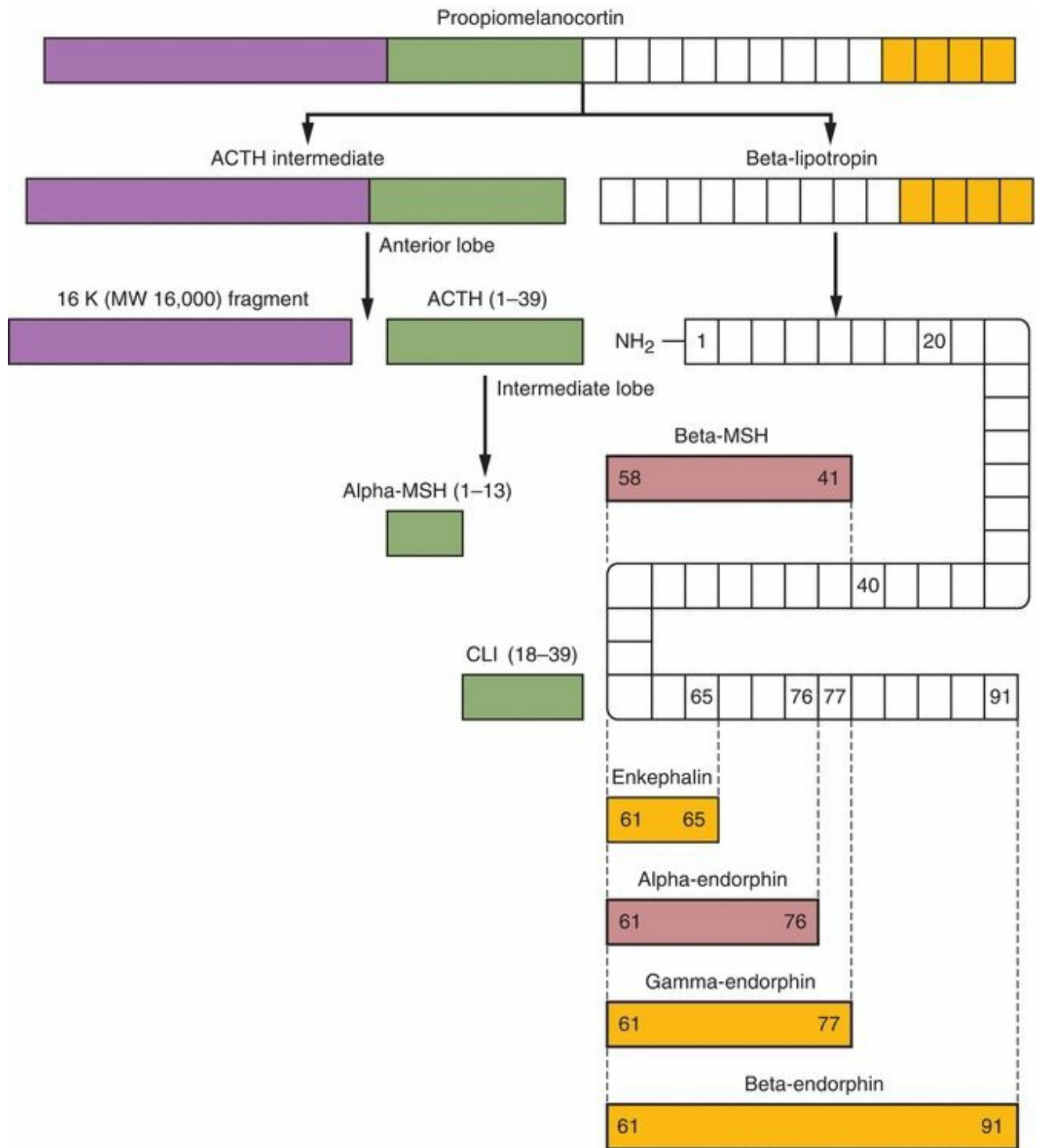
---

**In summary, synthesis and secretion of pituitary gonadotropins are under control of hypothalamic GnRH, as well as influenced to varying degree, by activin, inhibin, and follistatin. Activin enhances and follistatin suppresses GnRH activity. Evidence in vivo and in vitro indicates that gonadotropin response to GnRH requires activin activity, and gonadotropin response can be blocked by follistatin.<sup>92,93,94</sup> This relationship contributes to the down-regulation of pituitary gonadotropin secretion by prolonged GnRH stimulation. Increasing GnRH pulse frequency first increases FSH production, and, then with sustained high frequency or continuous GnRH stimulation, follistatin production is increased.<sup>92</sup> Selective synthesis and secretion of FSH can be explained by the decrease in the inhibiting factors, inhibin and follistatin, allowing activin to enhance the actions of GnRH, involving the transcription factors that promote FSH  $\beta$ -subunit expression.<sup>95</sup> LH secretion is primarily regulated by GnRH, without involvement of the inhibin-activin-follistatin system.**

# THE ENDOGENOUS OPIATES

---

The most fascinating peptide group is the endogenous opioid peptide family (**Figure 4.12**).<sup>96</sup>  $\beta$ -Lipotropin is a 91 amino acid molecule that was first isolated from the pituitary in 1964. Its function remained a mystery for more than 10 years until receptors for opioid compounds were identified, and, by virtue of their existence, it was postulated that endogenous opioid compounds must exist and serve important physiologic roles. Endorphin was a word coined to denote morphine-like action and endogenous origin in the brain.



**FIGURE 4.12**

Opiate production is regulated by gene transcription and the synthesis of precursor peptides and at a posttranslational level where the precursors are processed into the various bioactive smaller peptides.<sup>97</sup> All opiates derive from one of three precursor peptides.

- **Proopiomelanocortin (POMC)**—the source of endorphins
- **Proenkephalin A and B**—yields several enkephalins
- **Prodynorphin**—yields dynorphins

POMC was the first precursor peptide to be identified. It is made in the anterior and intermediate lobes of the pituitary, in the hypothalamus and other areas of the brain, in the sympathetic nervous system and in many other tissues including the gonads, the placenta, the gastrointestinal tract, and lungs; the highest concentrations are found in the pituitary gland.

POMC is split into two fragments, an ACTH intermediate fragment and the  $\beta$ -lipotropin. The  $\beta$ -lipotropin has no opioid activity but is broken down in a series of steps to  $\beta$ -melanocyte-stimulating hormone ( $\beta$ -MSH), enkephalin, and  $\alpha$ -,  $\gamma$ -, and  $\beta$ -endorphins. In lower animals,  $\beta$ -MSH acts to stimulate melanin granules within cells, causing darkening of the skin. In humans, however, there is no known function of  $\beta$ -MSH.

Enkephalin and the  $\alpha$ - and  $\gamma$ -endorphins are active opioids, almost as active as morphine on a molar basis, whereas  $\beta$ -endorphin is 5–10 times more potent. In the adult pituitary gland, the major products are ACTH and  $\beta$ -lipotropin, with only small amounts of endorphin. Thus, ACTH and  $\beta$ -lipotropin blood levels show similar courses, and they are major secretion products of the anterior pituitary in response to stress. In the intermediate lobe of the pituitary (which is prominent only during fetal life), ACTH is cleaved to CLIP (corticotropin-like intermediate lobe peptide) and  $\beta$ -MSH. In the placenta and the adrenal medulla, POMC processing yields  $\alpha$ -MSH-like and  $\beta$ -endorphin peptides.  $\beta$ -Endorphin has also been detected in the ovaries and in the testes.

In the brain, the major products are the opiates, with little ACTH. In the hypothalamus, the major products are  $\beta$ -endorphin and  $\alpha$ -MSH in the region of the arcuate nucleus and the ventromedial nucleus. **The pituitary opiate system is a system for secretion into the circulation, whereas the hypothalamic opiate system allows for distribution via axons to regulate other brain regions and the pituitary gland.**

$\beta$ -Endorphin is appropriately considered a neurotransmitter, a neurohormone, and a neuromodulator and is recognized to influence a variety of hypothalamic functions, including regulation of reproduction, temperature, and cardiovascular and respiratory function; it additionally influences extra-hypothalamic functions such as pain perception and mood. POMC gene expression in the anterior pituitary is controlled mainly by the CRH and influenced by the feedback effects of glucocorticoids. In the hypothalamus, regulation of POMC gene expression is via the sex steroids.<sup>98</sup> In the absence of sex steroids, little, if any, secretion occurs.

Proenkephalin A is produced in the adrenal medulla, the brain, the posterior



pituitary, the spinal cord, and the gastrointestinal tract. It yields several enkephalins: methionine-enkephalin, leucine-enkephalin, and other variants. The enkephalins are the most widely distributed endogenous opioid peptides in the brain and are probably mainly involved as inhibitory neurotransmitters in the modulation of the autonomic nervous system. Prodynorphin, found in the brain (concentrated in the hypothalamus) and the gastrointestinal tract, yields dynorphin, an opioid peptide with high analgesic potency and behavioral effects, as well as  $\alpha$ -neoendorphin,  $\beta$ -neoendorphin, and leumorphin. The last 13 amino acids of leumorphin constitute another opioid peptide, rimorphin. The prodynorphin products probably function in a fashion similar to endorphin.

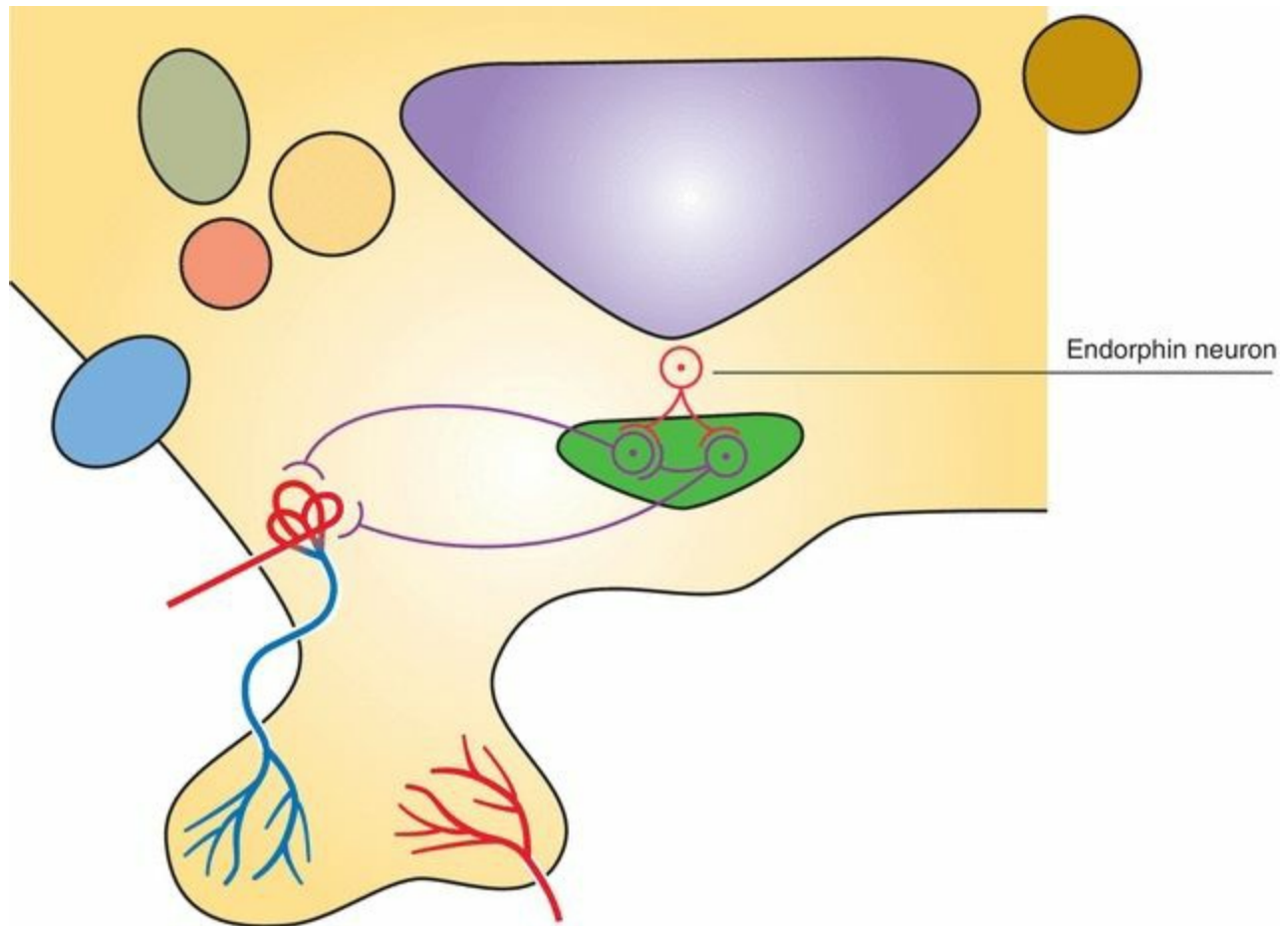
**It is simpler to say that there are three classes of opiates: enkephalin, endorphin, and dynorphin.**

Opioid peptides are able to act through different receptors, although specific opiates bind predominantly to one of the various receptor types. Naloxone, used in most human studies, does not bind exclusively to any one receptor type, and, thus, results with this opioid antagonist are not totally specific. Localization of opioid receptors explains many of the pharmacologic actions of the opiates. Opioid receptors are found in the nerve endings of sensory neurons, in the limbic system (site of euphoric emotions), in brainstem centers for reflexes such as respiration, and widely distributed in the brain and the spinal cord.

# Opioid Peptides and the Menstrual Cycle

The opioid tone is an important regulator of the menstrual function and menstrual cyclicity.<sup>99</sup> Although estradiol alone increases endorphin secretion, the highest levels of endorphin occur with sequential therapy of both estradiol and progesterone (in ovariectomized monkeys). Endogenous endorphin levels, therefore, increase throughout the cycle from nadir levels during menses (when estradiol levels are at the low) to the highest levels during the luteal phase (when both progesterone and estradiol levels are increased). Normal menstrual cyclicity, thus, requires sequential periods of high (luteal phase) and low (during menses) hypothalamic opioid activity.

A reduction in LH pulse frequency is linked to increased endorphin release.<sup>100</sup> Naloxone increases both the frequency and the amplitude of LH pulses. **Thus, the endogenous opiates inhibit gonadotropin secretion by suppressing the hypothalamic release of GnRH (Figure 4.13).** Opiates have no effect on the pituitary response to GnRH. The gonadal steroids modify endogenous opioid activity, and the negative feedback of steroids on gonadotropins appears to be mediated by endogenous opiates. Because the fluctuating levels of endogenous opiates in the menstrual cycle are related to the changing levels of estradiol and progesterone, it is attractive to speculate that the sex steroids directly stimulate endogenous opioid receptor activity. There is an absence of opioid effect on postmenopausal and oophorectomized levels of gonadotropins, and the response to opiates is restored with the administration of estrogen, progesterone, or both.<sup>101</sup> Both estrogen and progesterone alone increase endogenous opiates, but estrogen enhances the action of progesterone, which could explain the maximal suppression of GnRH and gonadotropin pulse frequency during the luteal phase.<sup>102,103</sup> In pubertal boys and girls, however, naloxone could not prevent the suppression of LH by estradiol administration, indicating that in this circumstance, estradiol may directly inhibit GnRH secretion.<sup>104,105</sup> Nevertheless, the evidence overall indicates that endogenous opiates exert an inhibiting influence over GnRH secretion.<sup>106</sup> The negative feedback of progesterone on GnRH secretion (the major mechanism for the inhibition of ovulation associated with progestin contraception) is definitely partly mediated by endogenous opiates but also by other neural mechanisms not yet determined.<sup>107</sup>



**FIGURE 4.13**

The inhibiting tone of endogenous opiates on GnRH secretion is reduced at the time of the ovulatory surge, allowing a release from suppression.<sup>108</sup> This is probably a response to estrogen, specifically an estrogen-induced decrease in opioid receptor binding and opioid release.<sup>109,110</sup>

Experiments with naloxone administration suggest that the suppression of gonadotropins during pregnancy and the recovery during the postpartum period reflect steroid-induced opioid inhibition, followed by a release from central opioid suppression.

The principal endogenous opiates affecting GnRH release are  $\beta$ -endorphin and dynorphin, and it is probable that the major effect is modulation of the catecholamine pathway, principally norepinephrine. The action does not involve dopamine receptors, acetylcholine receptors, or  $\alpha$ -adrenergic receptors. On the other hand, endorphin may affect GnRH release directly, without the involvement of any intermediary neuroamine.

Because  $\alpha$ -MSH counteracts the effects of  $\beta$ -endorphin, posttranslational processing of POMC can affect hypothalamic-pituitary function by altering the amounts of  $\alpha$ -MSH

and  $\beta$ -endorphin.<sup>111</sup> This introduces another potential site for neuroendocrine regulation of reproductive function. Gonadal hormones likely have multiple sites for feedback signals.

# Clinical Implications

A change in the opioid inhibitory tone is not important in the neuroendocrine events of puberty because the responsiveness to naloxone does not develop until after puberty. Alteration in the opioid tone does seem to mediate the hypogonadotropic state seen with elevated prolactin levels, excessive exercise, and other conditions of hypothalamic amenorrhea, whereas endogenous opioid inhibition does not seem to play a causal role in cases of delayed puberty or hereditary problems such as Kallmann syndrome.<sup>112,113</sup> Treatment of patients with hypothalamic amenorrhea (characterized by suppressed GnRH pulsatile secretion) with a drug (naltrexone) that blocks opioid receptors restores normal function (ovulation, menstrual cycles, and pregnancy).<sup>114</sup> These data suggest that the reduced GnRH secretion associated with hypothalamic amenorrhea is mediated by an increase in endogenous opioid inhibitory tone.

Experimental evidence indicates that hypothalamic CRH inhibits hypothalamic GnRH secretion, both directly and by augmenting endogenous opioid secretion. Women with hypothalamic amenorrhea demonstrate hypercortisolism, suggesting that this is the pathway by which stress interrupts reproductive function.<sup>115</sup> Mathematical analysis of the associations among FSH, LH,  $\beta$ -endorphin, and cortisol pulses support the existence of significant functional coupling between the neuroregulatory systems that control the gonadal and adrenal axes.<sup>116</sup> The CRH gene contains two segments that are similar to estrogen response elements, allowing estrogen enhancement of CRH activity, perhaps explaining the greater vulnerability of the reproductive axis to stress in females.<sup>117</sup> Besides the CRH-induced inhibition of GnRH release, the increase in cortisol generated by CRH stimulation of pituitary ACTH secretion also contributes to the suppression of reproduction; cortisol directly inhibits pituitary responsiveness to GnRH.<sup>118</sup>

Cumming concluded that most studies indicate an exercise-induced increase in endogenous opiates, but a significant impact on mood remains to be substantiated.<sup>119</sup> He noted that runners' high is more common in California than in Canada (euphoria is hard to come by when running in below freezing temperatures!).

Administration of morphine, enkephalin analogs, and  $\beta$ -endorphin causes release of prolactin. The effect is mediated by inhibition of dopamine secretion in the tuberoinfundibular neurons in the median eminence. Most studies have reported no effect of naloxone on basal, stress-induced, or pregnant levels of prolactin nor on prolactin secretion by prolactinomas. Thus, a physiologic role for endogenous opioid regulation of prolactin does not appear to exist in men and women. However, suppression of GnRH secretion associated with hyperprolactinemia does appear to be mediated by endogenous opiates.<sup>120</sup>

Every pituitary hormone appears to be modulated by endogenous opiates. Physiologic effects are important with ACTH, gonadotropins, and possibly vasopressin (posterior pituitary hormone). Opioid compounds, however, have no direct action on the pituitary nor do they alter the action of releasing hormones on the pituitary.

POMC-like mRNA is present in the ovary and the placenta,<sup>121</sup> although reasons for endorphin presence in these tissues are not yet apparent. Expression is regulated by gonadotropins in the ovary but not in the placenta. High concentrations of all of the members of the POMC family are found in human ovarian follicular fluid, but only  $\beta$ -endorphin shows significant changes during the menstrual cycle, reaching highest levels just before ovulation.<sup>122</sup>

# CATECHOL ESTROGENS

The enzyme that converts estrogens to catechol estrogens (2-hydroxylase) is richly concentrated in the hypothalamus; hence, there are higher concentrations of catechol estrogens than of estrone and estradiol in the hypothalamus and the pituitary gland. Because catechol estrogens have two faces (a catechol side and an estrogen side), they have the potential for interacting with both catecholamine and estrogen-mediated systems.<sup>123</sup> To be specific, catechol estrogens can inhibit tyrosine hydroxylase (which would decrease catecholamines) and compete for catechol-O-methyltransferase (which would increase catecholamines). Because GnRH, estrogens, and catechol estrogens are located in similar sites, it is possible that catechol estrogens may serve to interact between catecholamines and GnRH secretion. However, these functions remain speculative because a definite role for catechol steroids has not been established (Figure 4.14).

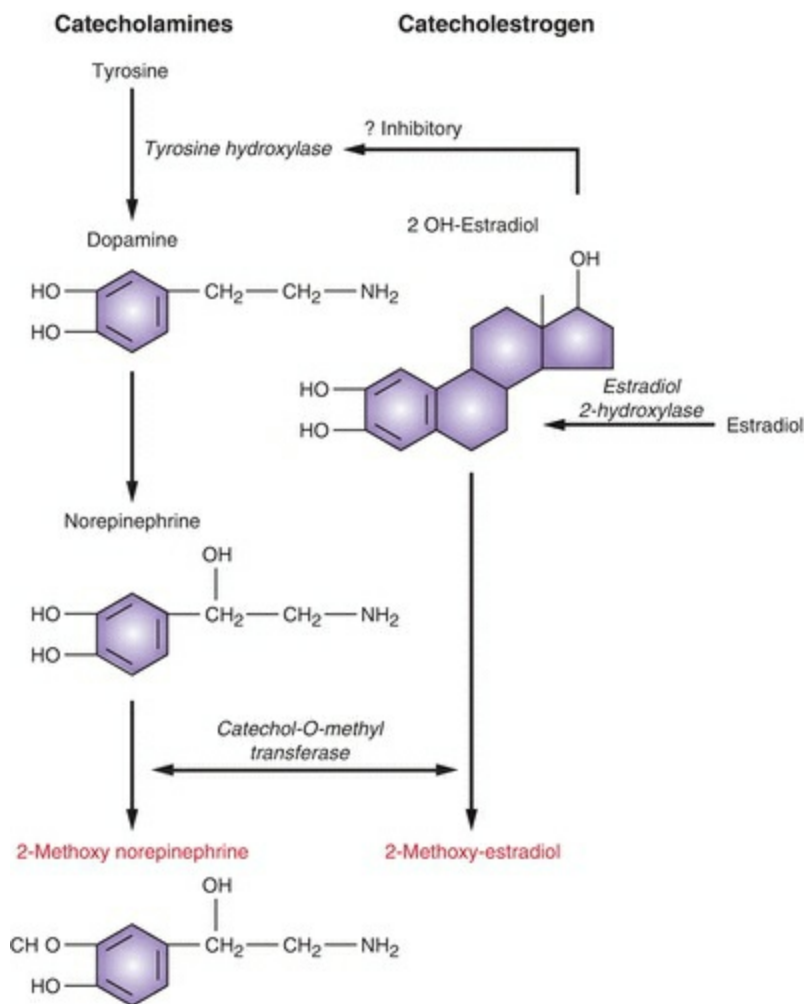


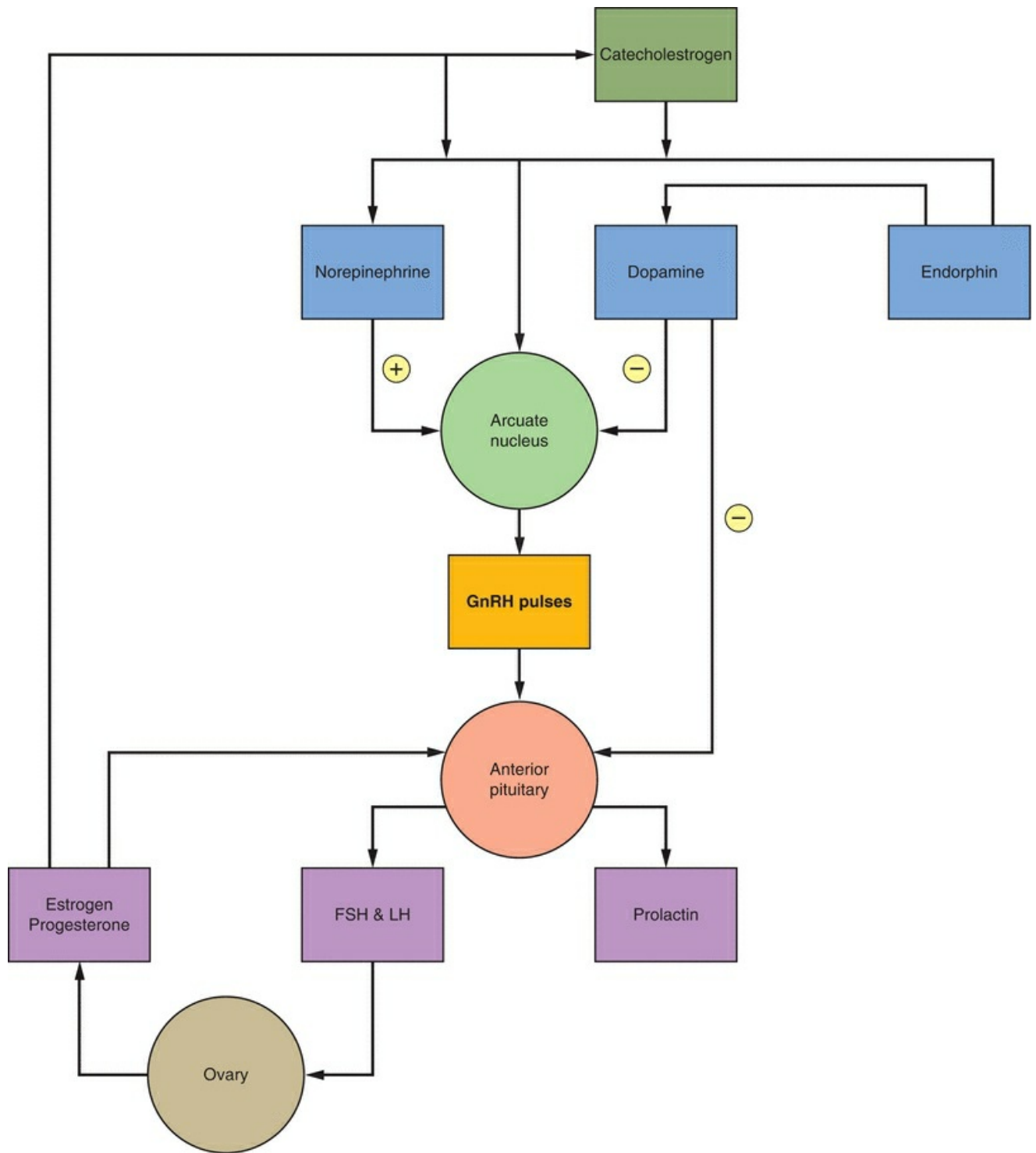
FIGURE 4.14

# **SUMMARY: CONTROL OF GNRH PULSES**

---

The key concept is that normal menstrual function requires GnRH pulsatile secretion in critical ranges of both pulse frequency and amplitude.<sup>45,48,124</sup> The normal physiology and pathophysiology of the menstrual cycle, at least in terms of central control, can be explained by mechanisms that affect the pulsatile secretion of GnRH. The pulses of GnRH are directly under the influence of a dual catecholaminergic system: norepinephrine (facilitatory) and dopamine (inhibitory). In turn, the catecholamine system can be influenced by endogenous opioid activity. The feedback effects of steroids can be mediated through this system via catechol steroid messengers or directly by influencing the various neurotransmitters (**Figure 4.15**).





**FIGURE 4.15**

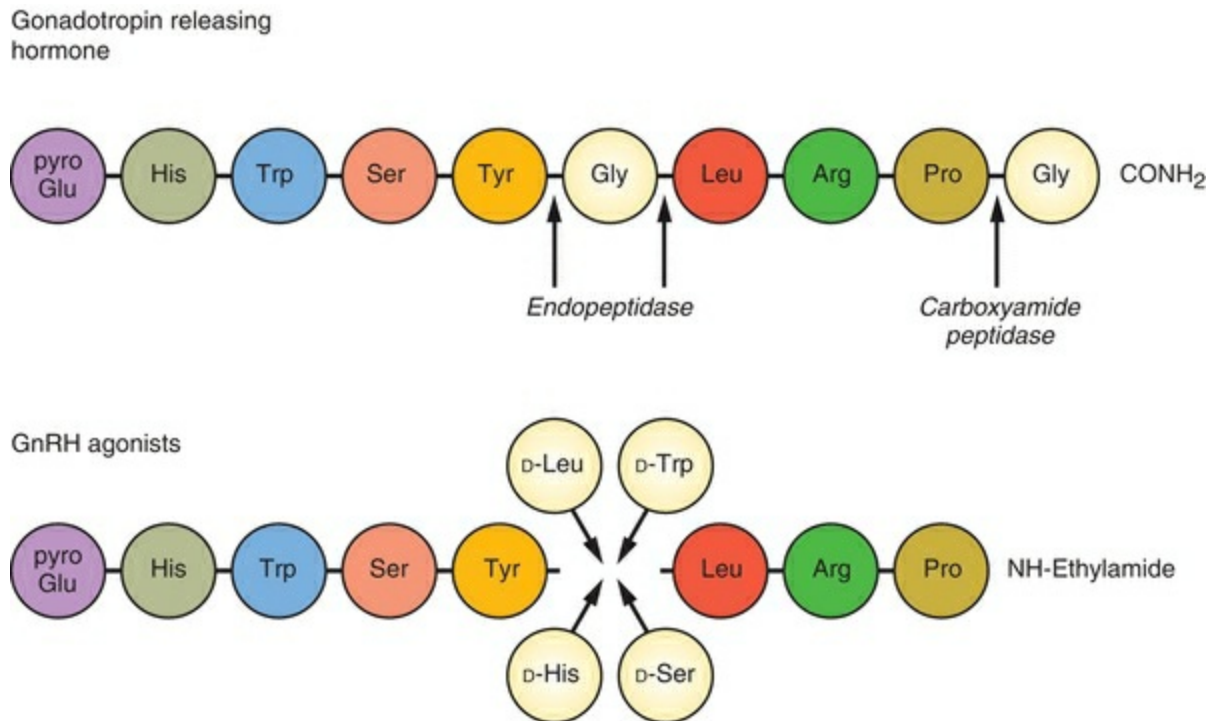
# GNRH AGONISTS AND ANTAGONISTS

---

The short half-life of GnRH is due to rapid cleavage of the bonds between amino acids 5–6, 6–7, and 9–10. By altering amino acids at these positions, analogues of GnRH can be synthesized with different properties. Substitution of amino acids at the 6 position or replacement of the C-terminal glycineamide (inhibiting degradation) produces analogues that act as GnRH agonists. In clinical practice, the GnRH agonists can be administered either intramuscularly or subcutaneously or by intranasal absorption. An initial agonistic action (the so-called flare effect) is associated with an increase in the circulating levels of FSH and LH. This response is greatest when the agonist is administered in the early follicular phase of menstrual cycle when GnRH and estradiol have combined to create a large reserve pool of gonadotropins ready for secretion. After 1–3 weeks of continuous presence of a GnRH agonist, desensitization and down-regulation of the pituitary occurs, resulting in a hypogonadotropic (low circulating FSH and LH levels), hypogonadal (low estradiol levels) state. The initial suppressive response is due to desensitization, whereas the sustained response is due to loss of receptors and the uncoupling of the receptor from its effector system. Furthermore, postreceptor mechanisms lead to secretion of biologically inactive gonadotropins, which, however, can still be detected by immunoassay.

Suppression of pituitary secretion of gonadotropins and resulting state of hypoestrogenism with the use of a GnRH agonist can be used for the treatment of estrogen dependent disorders such as endometriosis, uterine leiomyomas, precocious puberty, for the prevention of menstrual bleeding in special clinical situations (e.g., in thrombocytopenic patients), as well as for management of states of hormonal dysfunction such as premenstrual dysphoric disorder (PMDD).

GnRH antagonists are synthesized with multiple amino acid substitutions (positions 2, 3); by binding to the GnRH receptor, GnRH antagonists provide competitive inhibition of the naturally occurring GnRH. Thus, GnRH antagonists produce an immediate decline in gonadotropin levels with an immediate therapeutic effect within 24–72 hours. The early products either lacked potency or were associated with undesirable side effects due to histamine release. Products are now available for use in the treatment of endometriosis, prostate cancer, precocious puberty, and female infertility ([Figure 4.16](#)).



**FIGURE 4.16**

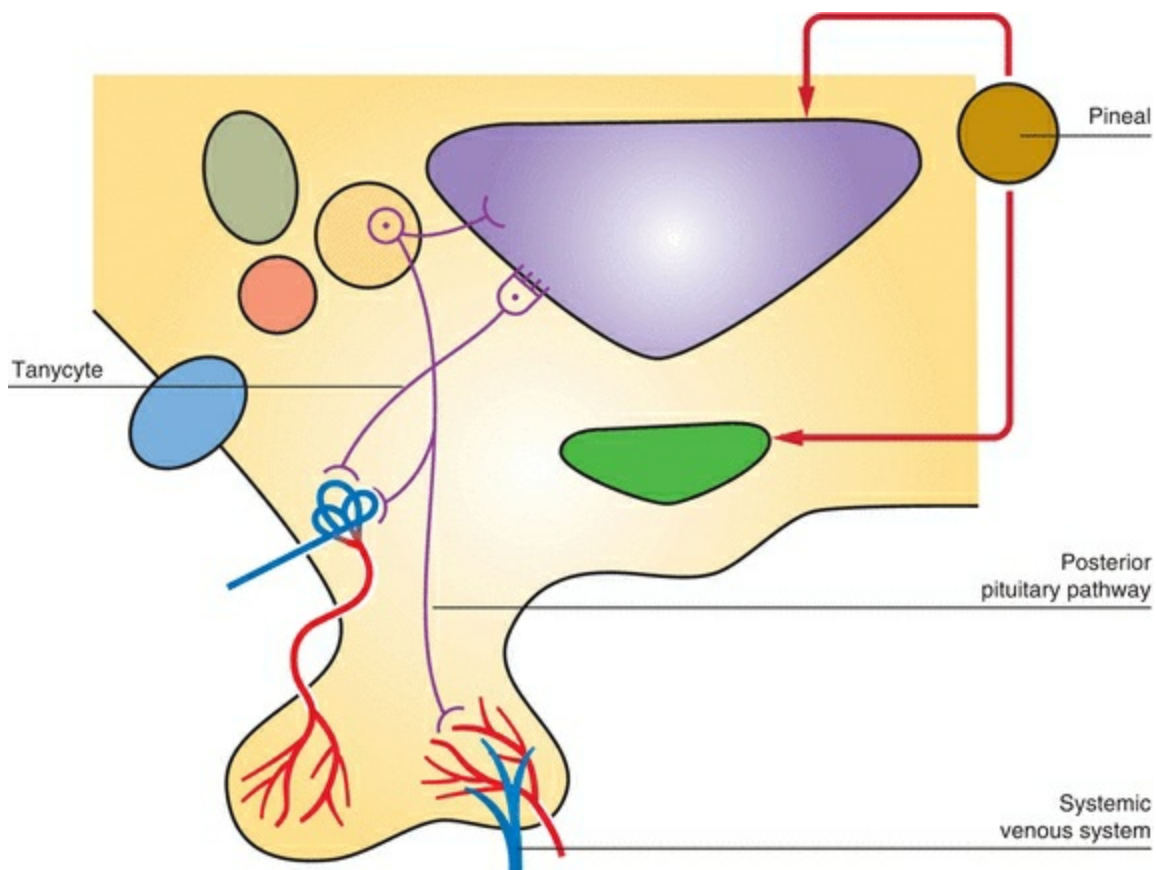
GnRH analogues (agonists and antagonists) have long been only available in non-oral forms due to susceptibility to destruction if administered orally. However, an oral GnRH antagonist formulation has recently been approved. Higher doses of GnRH analogues administered subcutaneously can achieve nearly equal effects as observed with intravenous and intramuscular treatment; however, the smaller blood peaks are slower to develop and take longer to return to baseline. Other forms of administration include nasal spray, sustained-release implants, and injections of biodegradable microspheres. With the nasal route, absorption enhancers have to be added to increase bioavailability; these agents produce considerable nasal irritation. The depot formulations of GnRH agonists are administered intramuscularly and are available as monthly and 3-monthly regimens. ([Table 4.2](#)).

## **TABLE 4.2 GnRH Agonists and Antagonists in Clinical Use**

Position	1	2	3	4	5	6	7	8	9	10	
Native GnRH-I	pGlu	His	Trp	Ser	Tyr	Gly		Leu	Arg	Pro	Gly-NH <sub>2</sub>
Native GnRH-II	pGlu	His	Trp	Ser	His	Gly		Trp	Tyr	Pro	Gly-NH <sub>2</sub>
Leuprolide						D-Leu					NH-ethylamide
Buserelin						D-Ser (tertiary butanol)					NH-ethylamide
Nafarelin						D-Naphthylalanine (2)					
Histrelin						D-His (tertiary benzyl)					NH-ethylamide
Goserelin						D-Ser (tertiary butanol)					Aza-Gly
Deslorelin						D-Trp					NH-ethylamide
Triptorelin						D-Trp					
Abarelix	D-Ala	D-Phe	D-Ala			D-Asp		Lys-(iPr)			D-Ala
Cetrorelix	D-Nal	D-Phe	D-Pal			D-Cit					D-Ala
Ganirelix	D-Nal	D-Phe	D-Pal			D-hArg		hArg			D-Ala

# TANYCYTES

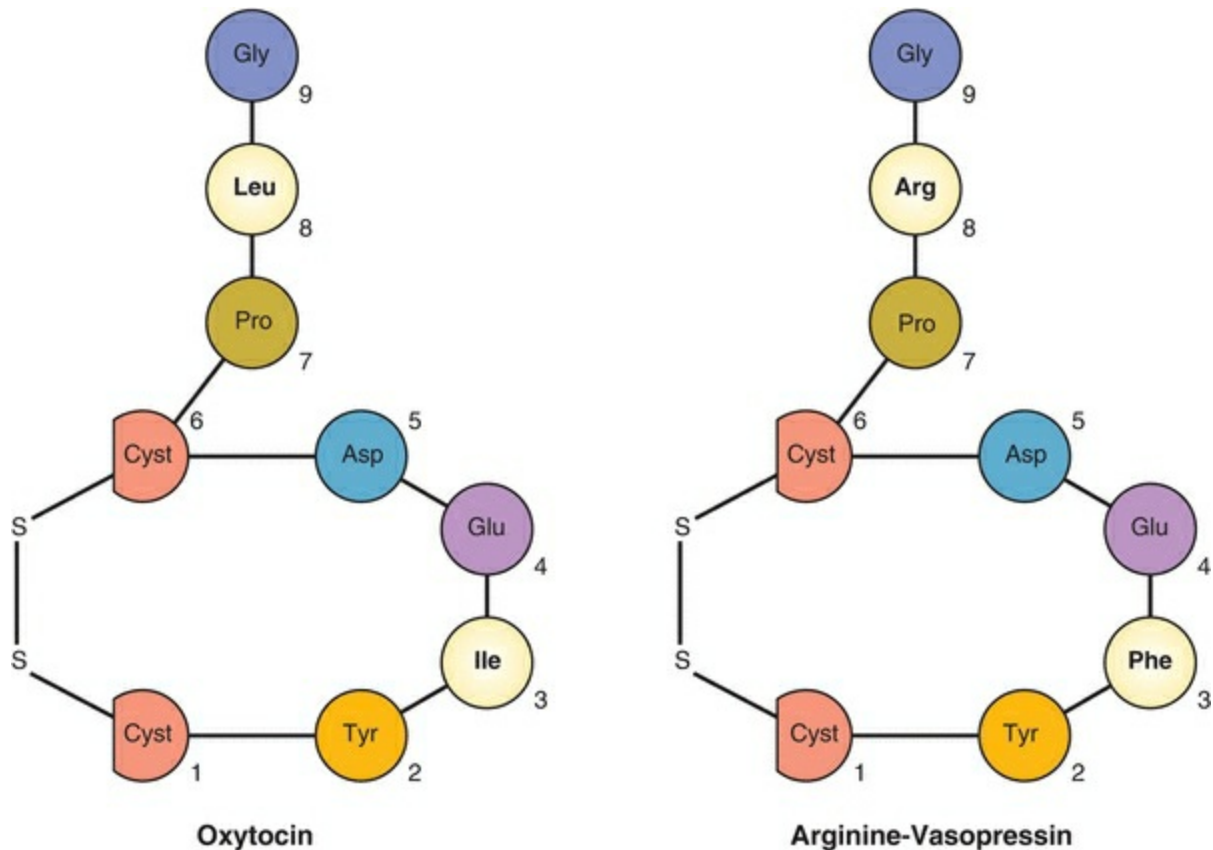
A significant pathway for hypothalamic influence may be via the cerebrospinal fluid (CSF). Tanycytes are specialized ependymal cells whose ciliated cell bodies line the third ventricle over the median eminence. The cells terminate on portal vessels, and they can transport materials from ventricular CSF to the portal system, for example, substances from the pineal gland, or vasopressin, or oxytocin. Tanycytes change morphologically in response to steroids and exhibit morphologic changes during the ovarian cycle (Figure 4.17).



**FIGURE 4.17**

# THE POSTERIOR PITUITARY PATHWAY

The posterior pituitary is a direct prolongation of the hypothalamus via the pituitary stalk, whereas the anterior pituitary arises from pharyngeal epithelium that migrates into position with the posterior pituitary. Separate neurosecretory cells in both the supraoptic and paraventricular nuclei make vasopressin and oxytocin as parts of large precursor molecules that also contain the transport peptide, neurophysin.<sup>125</sup> Both oxytocin and vasopressin consist of nine amino acid residues, two of which are half cystines forming a bridge between positions 1 and 6 (Figure 4.18). In the human, vasopressin contains arginine, unlike animals that have lysine vasopressin. The neurophysins are polypeptides with a molecular weight of about 10,000. There are two distinct neurophysins, the estrogen-stimulated neurophysin known as neurophysin I and the nicotine-stimulated neurophysin known as neurophysin II.



**FIGURE 4.18**

The genes for oxytocin and vasopressin are closely linked on chromosome 20, derived from a common ancestor about 400 million years ago.<sup>126</sup> The transcriptional activity of these genes is regulated by endocrine factors, such as the sex steroids and thyroid

hormone, through hormone response elements located upstream. The neurons secrete two large protein molecules, a precursor called propressophysin, which contains vasopressin and its neurophysin, and a precursor called prooxyphysin, which contains oxytocin and its neurophysin.<sup>125</sup> Neurophysin I is specifically related to oxytocin, and neurophysin II accompanies vasopressin. Because of this unique packaging, the hormones and their neurophysins are stored together and released at the same time into the circulation. The neurophysins are cleaved from their associated neurohormones during axonal transport from the neuronal cell bodies in the supraoptic and paraventricular nuclei to the posterior pituitary. The only known function for the neurophysins is axonal transport of oxytocin and vasopressin. Mutations in the gene encoding the precursor prohormone protein produce an alteration in the neurophysin, preventing the conformational shape necessary for transport of vasopressin to the pituitary gland, resulting in diabetes insipidus.<sup>127,128</sup>

The posterior pathway is complex and not limited to the transmission of vasopressin and oxytocin to the posterior pituitary. The transportation of vasopressin and oxytocin to the posterior pituitary occurs via nerve tracts that emanate from the supraoptic and paraventricular nuclei and descend through the median eminence to terminate in the posterior pituitary. However, these hormones are also secreted into the CSF and directly into the portal system. Therefore, vasopressin and oxytocin can reach the anterior pituitary and influence ACTH secretion (in the case of vasopressin) and gonadotropin secretion (in the case of oxytocin). Vasopressin cooperates with CRH to cause an increased yield of ACTH. Vasopressin and oxytocin-like materials are also found in the ovary, the oviduct, the testis, and the adrenal gland, suggesting that these neurohypophyseal peptides have roles as paracrine or autocrine hormones.<sup>129</sup> The concentrations of these substances in the CSF exhibit a circadian rhythm (with peak levels occurring during the day), suggesting a different mechanism for CSF secretion compared with posterior pituitary release.<sup>130</sup>

Neurophysin II is called nicotine neurophysin because the administration of nicotine or hemorrhage increases the circulating levels. Neurophysin I is called estrogen neurophysin because estrogen administration increases the levels in the peripheral blood, and peak levels of both neurophysin I and oxytocin are found at the time of the LH surge.<sup>131</sup> Oxytocin neurons and vasopressin neurons have been demonstrated in the rat to contain the estrogen receptor- $\beta$ .<sup>132</sup> The rise in estrogen neurophysin begins 10 hours after the rise in estrogen and precedes that of the LH surge, and the elevation of neurophysin lasts longer than the LH surge. Because GnRH and oxytocin are competing substrates for hypothalamic degradation enzymes, it has been hypothesized that oxytocin in the portal blood at the midcycle can inhibit the metabolism of GnRH, thus increasing the amount of GnRH available. Furthermore, oxytocin may have direct actions on the

pituitary, ovary, uterus, and fallopian tube during ovulation.

Neurophysin-containing pathways have been traced from the hypothalamic nuclei to various centers in the brainstem and the spinal cord. In addition, behavioral studies suggest a role for vasopressin in learning and memory. Administration of vasopressin has been associated with improvement in memory in brain-damaged human subjects and enhanced cognitive responses (learning and memory) in both young, normal individuals and depressed patients.

Both oxytocin and vasopressin circulate as the free peptides with a rapid half-life (initial component less than 1 minute, second component of 2–3 minutes). Three major stimuli for vasopressin secretion are changes in osmolality of the blood, alterations in blood volume, and psychogenic stimuli such as pain and fear. The osmoreceptors are located in the hypothalamus; the volume receptors are in the left atrium, aortic arch, and carotid sinus. Angiotensin II also produces a release of vasopressin, suggesting another mechanism for the link between fluid balance and vasopressin. Cortisol may modify the osmotic threshold for the release of vasopressin.

The major functions of vasopressin mainly involve the regulation of osmolality and blood volume, but also the release of insulin and ACTH, and influences on behavioral responses such as memory.<sup>133</sup> Vasopressin is a powerful vasoconstrictor and antidiuretic hormone (ADH). Vasopressin release increases when plasma osmolality rises and is inhibited by water loading (resulting in diuresis). Diabetes insipidus is a condition marked by loss of water because of a lack of vasopressin action in the tubules of the kidney, secondary to a defect in synthesis or secretion of vasopressin. The opposite condition is the continuous and autonomous secretion of vasopressin, the syndrome of inappropriate ADH secretion. This syndrome, with its resultant retention of water, is associated with a variety of brain disorders and with the production of vasopressin and its precursor by malignant tumors.

Oxytocin stimulates muscular contractions in the uterus and myoepithelial contractions in the breast. Thus, it is involved in parturition and the reflex letdown of milk. The release of oxytocin is so episodic that it is described as spurts. Ordinarily, there are about three spurts every 10 minutes. Oxytocin is released during coitus, probably by the Ferguson reflex (vaginal and cervical stimulation) but also by olfactory, visual, and auditory pathways. Perhaps oxytocin has some role in muscle contractions during orgasm.<sup>134</sup> In the male, release of oxytocin during coitus may contribute to sperm transport during ejaculation. Oxytocin is also released in specific areas of the brain, especially the ventromedial hypothalamus where it can act to inhibit appetite and stimulate sexual behavior.<sup>135</sup>

Using sensitive assays, an increase in maternal levels of oxytocin can be detected prior to parturition, occurring at first only at night.<sup>136,137</sup> Once labor has begun, oxytocin



levels rise significantly, especially during the second stage. Thus, oxytocin may be important for developing the more intense uterine contractions. Extremely high concentrations of oxytocin can be measured in the cord blood at delivery, and release of oxytocin from the fetal pituitary may also be involved in the onset and/or establishment of labor. However, this is controversial, and studies in monkeys fail to indicate a role for fetal oxytocin in parturition.<sup>137</sup> Part of the contribution of oxytocin to parturition is the stimulation of prostaglandin synthesis in decidua and myometrium.<sup>138</sup> Cervical dilation appears to be dependent on oxytocin stimulation of prostaglandin production, probably in the decidua. The greater frequency of labor and delivery at night may be due to greater nocturnal oxytocin secretion.<sup>136</sup> In addition, oxytocin is synthesized in the amnion, in the chorion, and, significantly, in the decidua.<sup>136</sup> This locally produced oxytocin may be a significant stimulus for myometrial and membrane production of prostaglandins.

It is likely that oxytocin action during the initial stages of labor depends on myometrial sensitivity to oxytocin in addition to the circulating levels of oxytocin. The concentration of oxytocin receptors in the myometrium is low in the nonpregnant state; myometrial expression of oxytocin receptors increases steadily throughout gestation (an 80-fold increase), and during labor, the myometrial concentration of oxytocin receptors doubles. The mechanism/s for this increase in myometrial expression of oxytocin receptors is unknown but is likely due to a change in the prostaglandin and hormonal milieu of the uterus. This receptor concentration correlates with the uterine sensitivity to oxytocin.<sup>139</sup> The local production and effects of oxytocin, estrogen, and progesterone combine in a complicated process of autocrine, paracrine, and endocrine actions to result in parturition.

Oxytocin is released in response to suckling, mediated through impulses generated at the nipple and transmitted via the third, fourth, and fifth thoracic nerves to the spinal cord and to the hypothalamus. In addition to causing milk ejection, the reflex is responsible for the uterine contractions associated with breastfeeding. Opioid peptides inhibit oxytocin release, and this may be how stress, fear, and anger inhibit milk output in lactating women. Oxytocin is also expressed in many tissues where it exerts autocrine-paracrine actions.

# THE BRAIN AND OVULATION

---

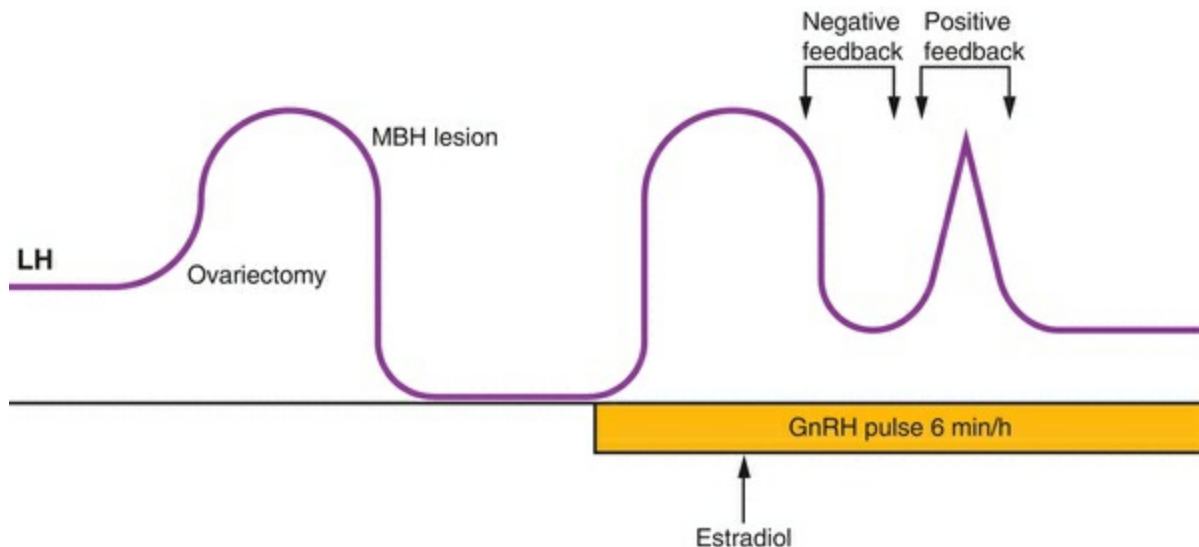
Classic studies in a variety of rodents indicated the presence of feedback centers in the hypothalamus that responded to steroids with the release of GnRH. The release of GnRH was the result of the complex, but coordinated, relationships among the neurohormones, the pituitary gonadotropins, and the gonadal steroids designated by the time-honored terms positive and negative feedback.

FSH levels were thought to be largely regulated by a negative inhibitory feedback relationship with estradiol. For LH, both a negative inhibitory feedback relationship with estradiol and a positive stimulatory feedback with high levels of estradiol were demonstrated. The feedback centers were in the hypothalamus and were called the tonic and cyclic centers. The tonic center controlled the day-to-day basal level of gonadotropins and was responsive to the negative feedback effects of sex steroids. The cyclic center in the female brain was responsible for the midcycle surge of gonadotropins, a response mediated by the positive feedback of estrogen. Specifically, the midcycle surge of gonadotropins was thought to be due to an outpouring of GnRH in response to the positive feedback action of estradiol on the cyclic center of the hypothalamus.

**This classic concept was not inaccurate. The problem was that the concept accurately described events in the rodent, but the mechanism is different in the primate.** Neuroendocrine genetic expression studies based on rodents duplicate the earlier studies, and once again support a hypothalamic “center” as the primary locus for sex steroid actions, but the primate operates differently.

In the primate, the “center” for the midcycle surge of gonadotropins moved from the hypothalamus to the pituitary. Experiments in the monkey demonstrated that GnRH, originating in the hypothalamus, plays a permissive and supportive role. Its pulsatile secretion is an important prerequisite for normal pituitary function,<sup>124</sup> but the feedback responses regulating gonadotropin levels are controlled by ovarian steroid feedback on the anterior pituitary cells.

The present concept is derived from experiments in which the medial basal hypothalamus was either destroyed<sup>42</sup> or the hypothalamus was surgically separated from the pituitary.<sup>140</sup> In a typical (and now classic) experiment, lesion of the medial basal hypothalamus by radiofrequency waves was followed by loss of LH levels as the source of GnRH was eliminated.<sup>41</sup> Administration of GnRH in a pulsatile fashion by an intravenous pump restored LH secretion. The administration of estradiol was then able to produce both negative and positive feedback responses, actions that certainly must be directly on the anterior pituitary because the hypothalamus was absent and GnRH was being administered in a steady and unchanging frequency and dose (**Figure 4.19**).



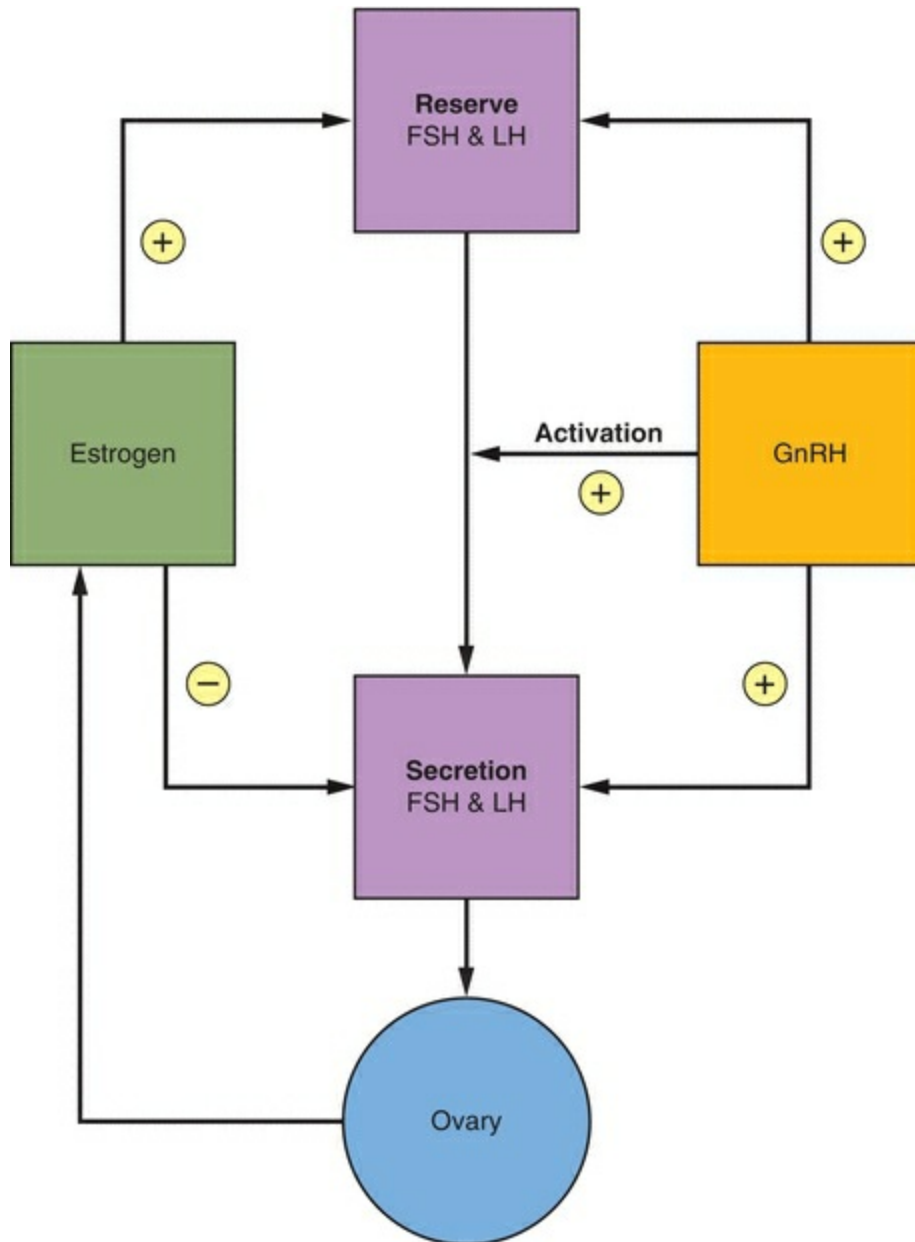
**FIGURE 4.19**

Administration of GnRH intravenously as a bolus produces an increase in blood levels of LH and FSH within 5 minutes, reaching a peak in about 20–25 minutes for LH and 45 minutes for FSH. Levels return to pretreatment values after several hours. When administered by constant infusion at submaximal doses, there is first a rapid rise with a peak at 30 minutes, followed by a plateau or fall between 45 and 90 minutes, and then a second and sustained increase at 225–240 minutes. This biphasic response suggests the presence of two functional pools of pituitary gonadotropins.<sup>141</sup> The readily releasable pool (secretion) produces the initial response, and the later response is dependent on a second, reserve pool of stored gonadotropins.

There are three principal positive actions of GnRH on gonadotropin elaboration:

1. **Synthesis and storage** (the reserve pool) of gonadotropins
2. **Activation**—movement of gonadotropins from the reserve pool to the releasable pool that is ready for direct secretion, a self-priming action
3. **Immediate release** (direct secretion) of gonadotropins

Gonadotropin secretion, synthesis, and storage change during the course of the menstrual cycle (**Figure 4.20**). At the beginning of the cycle, when estrogen levels are low, both secretion and storage levels are low. With increasing levels of estradiol, a greater increase occurs in storage, with little change in secretion. Thus, in the early follicular phase, estrogen has a positive effect on the synthesis and storage response, building up a supply of gonadotropins to meet the requirements of the impending midcycle surge. Premature release of gonadotropins is prevented by a negative (inhibitory) action of estradiol on the pituitary secretory response to GnRH.



**FIGURE 4.20**

As the midcycle approaches, subsequent responses to GnRH are greater than initial responses, indicating that each response not only induces release of gonadotropins but also activates the storage pool for the next response. This sensitizing or priming action of GnRH also involves an increase in the number of its own receptors and requires the presence of estrogen.<sup>142,143</sup> Estrogen itself is capable of increasing the number of GnRH receptors.<sup>80,144</sup> The rise in estrogen at midcycle prepares the gonadotropes to further respond to GnRH.

Because the midcycle surge of LH can be produced in the experimental monkey in the absence of a hypothalamus and in the face of unchanging GnRH, the ovulatory surge

of LH is believed to be a response to positive feedback action of estradiol on the anterior pituitary. When the estradiol level in the circulation reaches a critical concentration and this concentration is maintained for a critical time period, the inhibitory action on LH secretion changes to a stimulatory action. The exact mechanism of this steroid action is not known with certainty, but experimental evidence suggests that the positive feedback action of estradiol involves many mechanisms, including an increase in GnRH receptor concentration and an increase in pituitary sensitivity to GnRH. This action of estrogen is classically referred to as positive feedback, but it can also be viewed as an acute decrease in inhibitory influences.

The negative feedback of estrogen operates through different systems; at the pituitary level, estrogen inhibition of FSH secretion is associated with decreasing pituitary expression of activin.<sup>145,146,147,148</sup> In addition, estradiol directly inhibits the FSH  $\beta$  subunit gene by influencing corepressor proteins (adapter proteins) to bind to the gene and suppress transcription.<sup>149</sup>

**What a logical mechanism!** The midcycle surge must occur at the right time of the cycle to ovulate a ready and waiting mature follicle. What better way to achieve this extreme degree of coordination and timing than by the preovulatory follicle itself, through feedback effects of the sex steroids originating in the follicle that is destined to ovulate.

The presence of GnRH is certainly essential; the administration of a GnRH antagonist to women at midcycle prevents the LH surge.<sup>150</sup> GnRH is increased in the peripheral blood of women and the portal blood of monkeys at midcycle.<sup>151</sup> Although this increase may not be absolutely necessary (as demonstrated in the monkey experiments), studies do indicate that increased activity is occurring in both the hypothalamus and the pituitary.<sup>146,152,153,154</sup> Therefore, although the system can operate with only an unwavering, permissive action of GnRH, fine-tuning probably takes place by means of simultaneous effects on GnRH pulsatile secretion and pituitary response to GnRH. This is supported by gonadotropin gene expression studies, indicating steroid effects at both the hypothalamus and the pituitary.<sup>155</sup> The upstream region of the LH  $\beta$ -subunit gene binds the estrogen receptor, providing a means for direct steroid hormone modulation in the pituitary.<sup>156</sup>

The effect of estrogen on the hypothalamic release of GnRH was confusing at first because initial studies failed to detect the presence of estrogen receptors in GnRH neurons.<sup>157,158,159</sup> Later studies identified the more recently discovered estrogen receptor- $\beta$ , and experiments in knockout mice indicated that estrogen receptor- $\beta$  mediates estrogen effects on GnRH neurons.<sup>160,161,162</sup> Finally, more sophisticated methods and the knockout model demonstrated that both  $\alpha$  and  $\beta$  estrogen receptors are

present in GnRH neurons and are involved in cyclic changes in GnRH release.<sup>163,164,165</sup> The human GnRH gene contains a hormone-responsive element that binds estrogen and its receptor.<sup>166</sup> In molecular studies, estrogen decreased messenger RNA for GnRH-II but increased messenger RNA for GnRH-I.<sup>167</sup> In vivo studies in the sheep have demonstrated that estradiol has both negative and positive feedback effects on hypothalamic GnRH secretion and that a GnRH surge is involved in the preovulatory LH surge.<sup>168,169,170</sup> In monkeys, estrogen treatment decreases GnRH gene expression.<sup>171</sup> There no longer is any question that estrogen can regulate the activity of the hypothalamic GnRH neurons.<sup>172</sup>

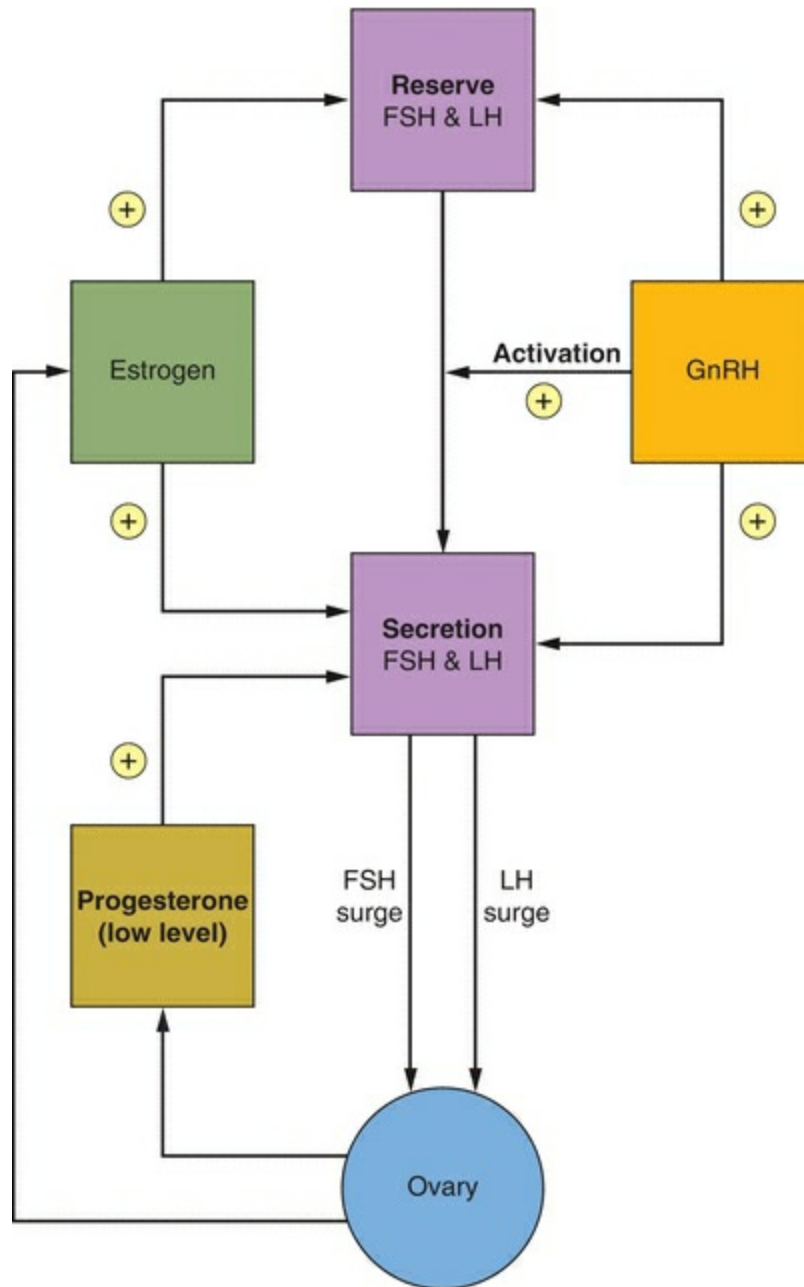
Influencing the hypothalamic frequency of GnRH secretion can in turn influence pituitary response to GnRH. Faster or slower frequencies of GnRH pulses result in lower GnRH receptor numbers in the pituitary.<sup>173</sup> Thus, a critical peak frequency is necessary for peak numbers of GnRH receptors and the peak midcycle response. Here is a method for the fine-tuning at both the hypothalamus (pulse frequency) and the pituitary (receptor number). Indeed, turning off the surge may involve down-regulation because of excessive GnRH. Studies in sheep indicate that a surge of GnRH at the time of the LH surge is associated with a switch from episodic secretion to continuous secretion into the portal circulation, producing the high exposure known to result in down-regulation.<sup>174</sup>

The differential response of FSH and LH, arising from the same pituitary cell, to the frequency of GnRH pulses is a consequence of the interplay among the regulating factors: the classic endocrine effects of estrogen, progesterone, and inhibin and the autocrine/paracrine actions of activin and follistatin.<sup>175</sup> The biphasic response of FSH, in particular, is modulated by the balance of activin and follistatin, created by the effects of estrogen and inhibin.

Another aspect of gonadotropin secretion is clinically important. A disparity exists between the quantity of gonadotropins measured during the midcycle surge as determined by immunoassay and bioassay. More FSH and LH are secreted at midcycle in a molecular form with greater biologic activity.<sup>176,177</sup> There is a well-established relationship between the activity and half-life of glycoprotein hormones and molecular composition (see [Chapter 2](#), under “Heterogeneity” of tropic hormones). The estrogen influence on gonadotropin synthesis is an additional method for maximizing the biologic effects of the midcycle surge. The bioactivity is also very dependent on pulsatile stimulation by GnRH. In addition to the change at midcycle that favors gonadotropin activity at the ovarian follicle, FSH isoforms with greater biologic activity also increase during the late luteal phase, a change that is appropriately geared toward propelling new ovarian follicle growth for the next cycle.<sup>178</sup>

The midcycle surge of FSH has an important clinical purpose. A normal corpus luteum requires the induction of an adequate number of LH receptors on granulosa cells, a specific action of FSH. In addition, FSH accomplishes important intrafollicular changes necessary for the physical expulsion of the ovum. The midcycle surge of FSH, therefore, plays a critical role in ensuring ovulation and a normal corpus luteum. Emerging progesterone secretion, just prior to ovulation, is the key.

Progesterone, at low levels and in the presence of estrogen, augments the pituitary secretion of LH and is responsible for the FSH surge in response to GnRH (**Figure 4.21**).<sup>179,180,181,182</sup> As the rising levels of LH produce the morphologic change of luteinization in the ovulating follicle, the granulosa layer begins to secrete progesterone directly into the bloodstream. The process of luteinization is inhibited by the presence of the oocyte; therefore, progesterone secretion is relatively suppressed, ensuring that only low levels of progesterone reach the brain.

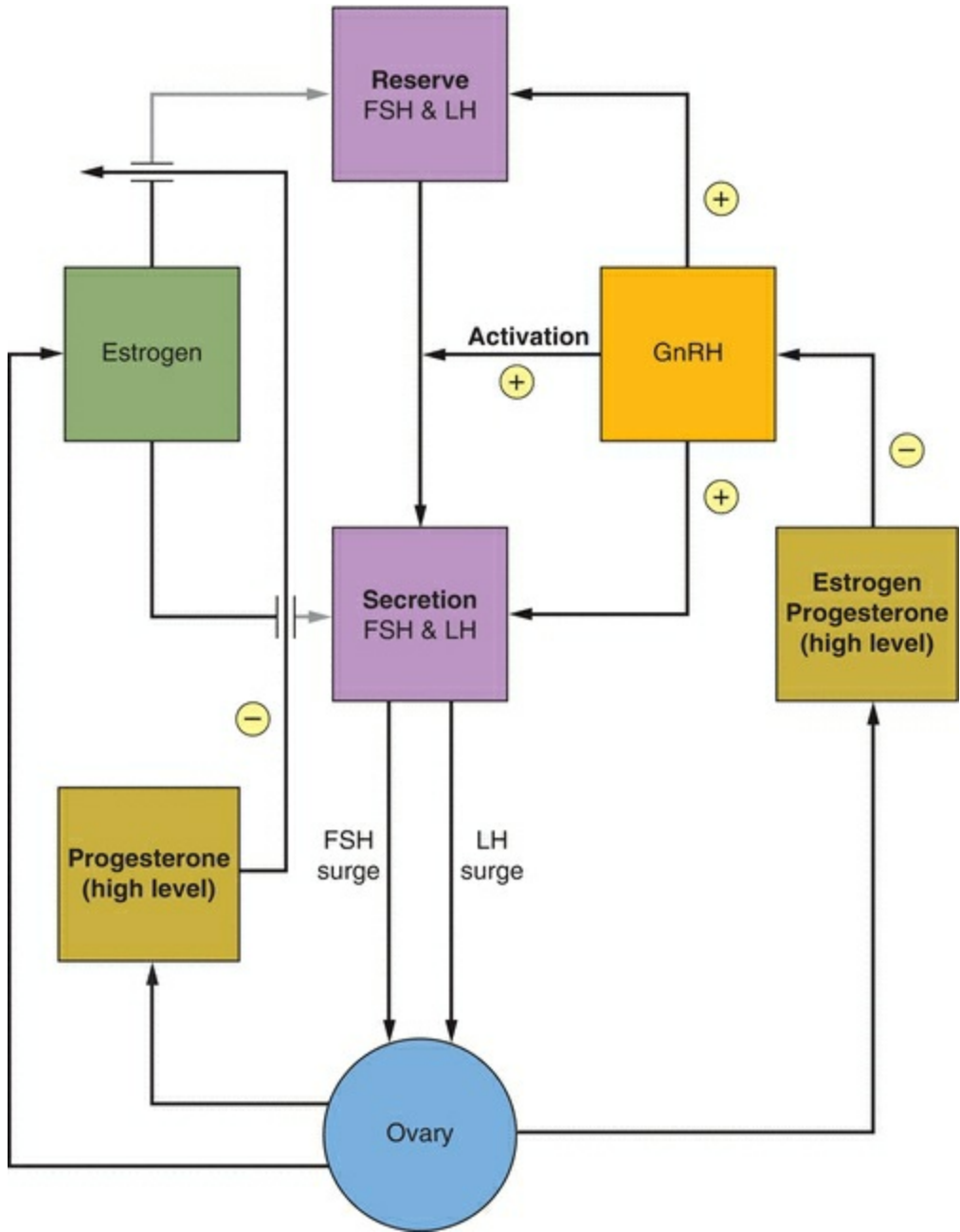


**FIGURE 4.21**

After ovulation, rapid and full luteinization is accompanied by a marked increase in progesterone levels, which, in the presence of estrogen, exercise a profound negative feedback action to suppress gonadotropin secretion (Figure 4.22). This action of progesterone takes place in two locations, the hypothalamus and the pituitary.<sup>183,184,185</sup> There definitely is a central action to decrease GnRH.<sup>186</sup> An important role for progesterone is to mediate the slowing of GnRH pulses in the late luteal phase, favoring the rise in FSH necessary to initiate the next cycle.<sup>51</sup> Progesterone fails to block estradiol-induced gonadotropin discharges in monkeys with hypothalamic lesions if



pulsatile GnRH replacement is provided. Therefore, high levels of progesterone inhibit ovulation at the hypothalamic level (Figure 4.21). In contrast, the facilitatory action of low levels of progesterone is exerted only at the pituitary on the response to GnRH (Figure 4.22).



**FIGURE 4.22**

## Key Points

- Pulsatile GnRH secretion must be within a critical range for both frequency and concentration (amplitude). This is absolutely necessary for normal reproductive function.
- GnRH has only positive actions on the anterior pituitary: synthesis and storage, activation, and secretion of gonadotropins. The gonadotropins are secreted in a pulsatile fashion in response to the similar pulsatile release of GnRH.
- Lower GnRH pulse frequencies, such as in the late luteal phase, favor FSH secretion, and higher GnRH pulse frequencies, as occur in the late follicular phase, favor LH secretion.
- Low levels of estrogen enhance FSH and LH synthesis and storage, have little effect on LH secretion, and inhibit FSH secretion.
- High levels of estrogen induce the LH surge at midcycle, and high steady levels of estrogen lead to sustained elevated LH secretion.
- Low levels of progesterone acting at the level of the pituitary gland enhance the LH response to GnRH and are responsible for the FSH surge at midcycle.
- High levels of progesterone inhibit pituitary secretion of gonadotropins by inhibiting GnRH pulses at the level of the hypothalamus. In addition, high levels of progesterone can antagonize pituitary response to GnRH by interfering with estrogen action.

# THE PINEAL GLAND

---

Although no physiologic role has been firmly established in the human, the reproductive functions of the hypothalamus may also be under inhibitory control of the brain via the pineal gland. The pineal arises as an outgrowth of the roof of the third ventricle, but soon after birth it loses all afferent and efferent neural connections with the brain. Instead, the parenchymal cells receive a new and unusual sympathetic innervation that allows the pineal gland to be an active neuroendocrine organ that responds to photic and hormonal stimuli and exhibits circadian rhythms.<sup>187,188,189</sup>

The neural pathway begins in the retina and passes through the suprachiasmatic and paraventricular nuclei in the hypothalamus to the inferior accessory optic tracts and the medial forebrain bundle to the upper spinal cord. Preganglionic fibers terminate at the superior cervical ganglion, and postganglionic sympathetic nerves terminate directly on pineal cells. Interruption of this pathway gives the same effect as darkness, which is an increase in pineal biosynthetic activity.

Hydroxyindole-O-methyltransferase (HIOMT), an enzyme essential for melatonin synthesis, is found mainly in pineal parenchymal cells, and its products are essentially unique to the pineal. Norepinephrine stimulates tryptophan entry into the pineal cell and also adenylate cyclase activity in the membrane. The resulting increase in cyclic AMP leads to N-acetyltransferase activity, the rate-limiting step in melatonin synthesis. Tryptophan is converted by the combined action of N-acetyltransferase and HIOMT into melatonin (N-acetyl-5-methoxytryptamine). Thus, melatonin synthesis is controlled by norepinephrine stimulation of adenylate cyclase, and the norepinephrine is liberated by sympathetic stimulation due to the absence of light. HIOMT is also found in the retina where melatonin may serve to regulate the pigment in retinal cells and in the intestine. However, pinealectomy completely eliminates detectable levels of melatonin in the circulation. Calcification of the pineal gland is common. It is frequently present in young children, and almost all elderly people have pineal calcification.

The association of hyperplastic pineal tumors with decreased gonadal function and of destructive tumors with precocious puberty suggested that the pineal is the source of gonadal inhibiting substances. However, pineal mechanisms cannot be essential for gonadal function. Normal reproductive function returns to the pinealectomized rat several weeks after pinealectomy; blind women have normal fertility, and pinealectomy in a primate did not affect pubertal development.<sup>190</sup>

## **DARKNESS → INCREASED MELATONIN → DECREASED GnRH**

A rat in constant light develops a small pineal gland with decreased HIOMT and melatonin, while the ovarian weight increases. A rat in constant dark has the opposite result, with increased pineal size, HIOMT, and melatonin, but with decreased ovarian

weight and pituitary function. A rhythm is established in pineal HIOMT activity by the presence or absence of light. Short days and long nights with increased melatonin secretion result in gonadal atrophy, and this is the major mechanism governing seasonal breeding.<sup>191,192</sup> In humans, melatonin secretion increases after darkness, peaks in the middle of the night, and then decreases. This rhythm is endogenous, originating in the suprachiasmatic nucleus. Light does not cause the rhythm, but influences its timing.

Possible roles of the pineal gland in humans may be to give circadian rhythmicity to other functions such as temperature and sleep. In all vertebrates tested so far, there is a daily and seasonal rhythm in melatonin secretion: high values during the dark and low during light, greater secretion in the winter compared with the summer. Desynchronization with travel across time zones may contribute to the symptom complex known as jet lag. Melatonin ingestion improves both the duration and quality of sleep, but the optimal timing of administration is unknown.<sup>189,193</sup>

The pineal, therefore, serves as an interface between the environment and hypothalamic-pituitary function. In order to correctly interpret day length, animals require a daily rhythm in melatonin secretion. This coordination of temporal, environmental information is especially important in seasonal breeders. This pineal rhythm appears to require the suprachiasmatic nucleus, perhaps the site at which pineal function and light changes are coordinated.

Melatonin is synthesized and secreted by the pineal gland and circulates in the blood like a classical hormone. It affects distant target organs, especially the neuroendocrine centers of the CNS. Whether melatonin is secreted primarily into the CSF or blood is still debated, but most evidence favors blood. Melatonin may reach the hypothalamus from the CSF by way of tanycyte transport.

The gonadal changes associated with melatonin are mediated via the hypothalamus and suggest a general suppressive effect on GnRH pulsatile secretion and reproductive function.<sup>194</sup> In humans, melatonin blood levels are highest in the first year of life (with highest levels at night), and then decrease with age, eventually releasing, some claim, the suppression of GnRH prior to puberty.<sup>191</sup> This hypothesis is challenged by the association of blindness in human females with an age of menarche that is earlier than normal.<sup>195</sup> Furthermore, pinealectomy in monkeys does not affect puberty.<sup>190</sup> Others have failed to find a decrease in melatonin levels with aging.<sup>196</sup>

Pineal activity can be viewed as the net balance between hormone- and neuron-mediated influences. The pineal contains receptors for the active sex hormones, estradiol, testosterone, dihydrotestosterone, progesterone, and prolactin. Furthermore, the pineal converts testosterone and progesterone to the active  $5\alpha$ -reduced metabolites, and androgens are aromatized to estrogens. The pineal also appears to be unique in that

a catechol amine neurotransmitter (norepinephrine), interacting with cell membrane receptors, stimulates cellular synthesis of estrogen and androgen receptors. In general, however, the sympathetic activity producing the circadian rhythm takes precedence over hormonal effects.

Despite a variety of suggestive leads, there is no definitive evidence for a role of the pineal in humans. Nevertheless, the important relationship between light exposure and circadian rhythms continues to focus attention on the pineal gland as a coordinator.<sup>197</sup> There is a seasonal distribution in human conception in northern countries with a decrease in ovarian activity and conception rates during the dark winter months.<sup>198,199</sup> In addition, the pineal can disrupt normal gonadal function. A male with delayed puberty due to hypogonadotropism has been described, who had an enlarged, hyperfunctional pineal gland.<sup>200</sup> Over time, his melatonin levels spontaneously decreased, and normal pituitary-gonadal function developed. Elevated nocturnal levels of melatonin have been reported in patients with hypothalamic amenorrhea and in women with anorexia nervosa, but this increase is probably a consequence of low estrogen levels, and not etiologic.<sup>194,201</sup>

A possible influence of the pineal gland may be the synchronization of menstrual cycles noted among women who spend time together. A significant increase in synchronization of cycles was first reported in 1971 among roommates and among closest friends in the first 4 months of residency in a dormitory of a women's college.<sup>32</sup> A similar increase in synchrony has been observed in women coworkers in occupations characterized by levels of interdependency that were equal to or greater than the levels of encountered job stress and in Bedouin families in which women live together for many years.<sup>33,35</sup> However, efforts to replicate these results have not always been successful.<sup>34,202</sup> There is also some evidence that the timing of ovulation can be affected by axillary human pheromones.<sup>31,203</sup>

Melatonin is available in 1- and 5-mg doses that produce blood levels that are 10–100 times higher than normal nighttime peaks.<sup>189,193</sup> The effects include increased sleepiness and decreased alertness. No data are available regarding long-term consequences on reproductive function.

A number of other indoles (also derivatives of tryptophan) have been identified in the pineal gland. Biologic roles for these indoles remain elusive, but one in particular has been extensively investigated. Arginine vasotocin differs from oxytocin by a single amino acid in position 8 and from vasopressin by a single amino acid in position 3. In general, arginine vasotocin has an inhibitory action on the gonads and pituitary secretion of prolactin and LH. Nevertheless a precise role continues to be evasive.

# GONADOTROPIN SECRETION THROUGH FETAL LIFE, CHILDHOOD, AND PUBERTY

---

We have often considered the endocrine events during puberty as an awakening, a beginning. However, endocrinologically, puberty is not a beginning but just another stage in a development that began at conception. The development of the anterior pituitary in the human starts between the 4th and 5th weeks of fetal life, and by the 12th week of gestation, the vascular connection between the hypothalamus and the pituitary is functional. Gonadotropin production has been documented throughout fetal life, during childhood, and into adult life.<sup>204</sup> Remarkable levels of FSH and LH, similar to postmenopausal levels, can be measured in the fetus. GnRH is detectable in the hypothalamus by 10 weeks of gestation, and by 10–13 weeks when the vascular connection is complete, FSH and LH are produced in the pituitary. The peak pituitary concentrations of FSH and LH occur at about 20–23 weeks, and peak circulating levels occur at 28 weeks of intrauterine life.

The increasing production rate of gonadotropins until midgestation reflects the growing ability of the hypothalamic-pituitary axis to perform at full capacity. Beginning at midgestation, there is an increasing sensitivity to inhibition by steroids and a resultant decrease in gonadotropin secretion. Full sensitivity to steroids is not reached until late in infancy. The rise in gonadotropins after birth reflects the loss of negative feedback that was exerted by the high in utero levels of placental steroids; this postnatal rise in gonadotropins is even greater in infants born prematurely. Thus, in the first year of life, there is considerable follicular activity in the ovaries in contrast to later in childhood when gonadotropin secretion is suppressed.

Testicular function in the fetus can be correlated with the fetal hormone patterns. Initial testosterone production and sexual differentiation are in response to the fetal levels of placental hCG, whereas further testosterone production and masculine differentiation are maintained by the fetal pituitary gonadotropins. Decreased testosterone levels in late gestation reflect the decrease in gonadotropin levels. The fetal generation of Leydig cells somehow avoids down-regulation and responds to high levels of hCG and LH by increased steroidogenesis and cell multiplication. This generation of cells is replaced by the adult generation that becomes functional at puberty and responds to high levels of hCG and LH with down-regulation and decreased steroidogenesis.

There is a sex difference in fetal gonadotropin levels. There are higher pituitary and circulating FSH and LH levels in female fetuses. The lower male levels are due to testicular testosterone and inhibin production. In infancy, the postnatal FSH rise is more marked and more sustained in females, whereas LH values are not as high. This early

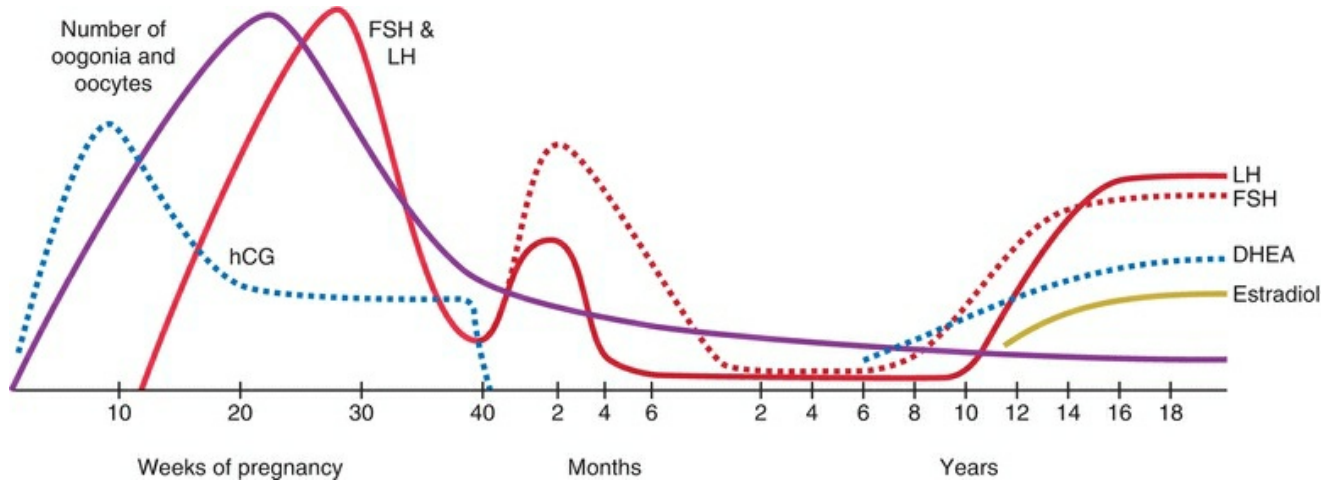
activity is accompanied by inhibin levels comparable to the low range observed during the follicular phase of the menstrual cycle.<sup>205</sup> After the postnatal rise, gonadotropin levels reach a nadir during early childhood (by about 6 months of age in males and 1–2 years in females) and then rise slightly between 4 and 10 years. The difference between males and females is notable; in the female, the suppression of gonadotropins begins later in childhood, is less intense than in the male, and the duration of suppression is shorter in females. The difference is believed to reflect the presence of testosterone in males.

This childhood period is characterized by low levels of gonadotropins in the pituitary and in the blood, little response of the pituitary to GnRH, and maximal hypothalamic suppression. This low level of activity is not maintained by the ovaries or testes because gonadal removal results in little change. Children without gonads experience this same low level of activity.<sup>206</sup> A central inhibitory force must be operating within the brain, awaiting a signal to initiate puberty.

The central inhibitory force restrains GnRH pulsatile secretion. The mechanism involves several neurotransmitters: GABA ( $\gamma$ -amino butyric acid), neuropeptide Y, and kisspeptin. GABA release in the hypothalamus declines as GnRH secretion increases at the onset of puberty, and blockade of GABA synthesis or activity can initiate puberty in monkeys.<sup>207,208</sup> Neuropeptide Y is recognized as an inhibitory neurotransmitter on GnRH pulsatility.<sup>209</sup> Kisspeptin is a newly appreciated neuroendocrine regulator of reproduction.<sup>210</sup> Kisspeptin expression is found in the arcuate nucleus of the hypothalamus and increases just prior to the resurgence of GnRH pulsatile secretion at puberty.<sup>211</sup> Mutations of the G-protein receptor for kisspeptin results in hypogonadotropic hypogonadism and a failure to enter puberty; these patients respond to either exogenous gonadotropins or GnRH. These are some of the signals involved, but the precise trigger that senses maturation and initiates the events of puberty remains elusive.

In girls, the first steroids to rise in the blood are dehydroepiandrosterone (DHEA) and its sulfate (DHEAS) beginning at 6–8 years of age, shortly before FSH begins to increase. Estrogen levels, as well as LH, do not begin to rise until 9–12 years of age (**Figure 4.23**). If the onset of puberty is triggered by the first hormone to increase in the circulation, then a role for adrenal steroids must be considered. However, there is no evidence to suggest that the adrenal steroids are necessary for the proper timing of puberty, and adrenarche is independent; it is not controlled by the same mechanism that turns on the gonads.<sup>212</sup> Indeed, a longitudinal study concluded that increasing adrenal steroid activity reflects gradually increasing maturation with aging, without a sudden change associated with puberty.<sup>213</sup> Neither is there a definite relationship demonstrated between melatonin secretion and puberty. Because the studies have focused on the

amount of melatonin secreted rather than the rhythm of secretion, this question remains open. Nutritional status influences reproductive function, and the leptin system of communication probably contributes to the onset of puberty, but it is unlikely that it is the primary signal (discussed in [Chapter 19](#)). Leptin circulating levels can indicate readiness for puberty, in this case, an indication of an adequate amount of fat tissue in the body to support the metabolic requirements of reproduction.<sup>214</sup> Indeed, a more logical concept is to view puberty as the coming together of multiple systems and influences, including genetic, metabolic, and hormonal factors.



**FIGURE 4.23**

Prior to puberty, gonadotropin levels are low but still associated with pulses (although quite irregular).<sup>215</sup> This prepubertal restraint involves brain peptides, especially GABA and neuropeptide Y.<sup>208,209</sup> The clinical onset of puberty is preceded by an increase in pulse frequency, amplitude, and regularity, especially during the night.<sup>215,216,217,218,219</sup> At the time of appearance of secondary sex characteristics, the mean LH levels are 2–4 times higher during sleep than during wakefulness. This pattern is not present before or after puberty and is an early sign of changes taking place in the hypothalamus, where there is increasing coordination of GnRH neurons with increasing GnRH pulsatile secretion. This pattern can be detected in individuals who develop increasing and decreasing degrees of hypothalamic suppression (e.g., in individuals with worsening and improving anorexia nervosa). FSH levels plateau by mid-puberty, whereas LH and estradiol levels continue to rise until late puberty. Biologically active LH has been found to rise proportionately more than immunoreactive LH with the onset of puberty.

The rise of gonadotropins at puberty must be independent of the gonads because the same response can be observed in patients with gonadal dysgenesis (who lack functional steroid-producing gonadal tissue). Adolescent girls with Turner syndrome



(45,X) also demonstrate augmented gonadotropin secretion during sleep.<sup>220</sup> Thus, maturation at puberty must involve changes in the hypothalamus that are independent of ovarian steroids.

The maturational change in the hypothalamus is followed by an orderly and predictable sequence of events. Increased GnRH secretion leads to increased pituitary responsiveness to GnRH (a combination of steroid influence on the pituitary and a frequency effect of GnRH pulses on GnRH receptor numbers), leading to increasing production and secretion of gonadotropins. Increased gonadotropins are responsible for follicular growth and development in the ovary and increased sex steroid levels. The rising estrogen contributes to achieving an adult pattern of pulsatile GnRH secretion, finally leading to cyclic menstrual patterns.

The age of onset of puberty is variable and influenced by genetic factors, socioeconomic conditions, and general health. A trend toward lowering of the menarcheal age and the period of acceleration of growth is recognized. In a 10-year prospective study of middle class American girls in the 1970s, the mean age of menarche was 12.83.<sup>221</sup> Studies analyzing data from the National Health and Nutrition Examination Survey (NHANES) have observed a 2.3 month decrease in the average age of menarche between surveys for the years 1988–1994 (12.53 years) and 1999–2002 (12.34 years), and an overall 4.9 months decrease since 1960.<sup>222</sup> This lowering in age of menarche has been observed in all ethnic groups, declining from 12.57 to 12.52 years in non-Hispanic white girls, from 12.09 to 12.06 years for non-Hispanic black girls, and from 12.24 to 12.09 for Hispanic American girls (Table 4.3).

## **TABLE 4.3 Racial and Ethnic Differences in Age of Menarche**

<b>Ethnic Group</b>	<b>Mean Age of Menarche</b>
Black girls	12.06 y
Mexican-American girls	12.09 y
White girls	12.52 y

The earlier menarche today compared with the past is undoubtedly due to improved nutrition and better health. It has been suggested that initiation of growth and menarche occur at a particular body weight (48 kg) and percent of body fat (17%).<sup>223</sup> It is thought that this relationship reflects a required stage of metabolism. Although this hypothesis relating a critical weight threshold for timing of menarche is a helpful concept, the extreme variability in onset of menarche indicates that there is no particular age or size at which an individual girl should be expected to experience menarche.

In the female, the typical sequence of events is growth initiation, thelarche, pubarche, and finally menarche. This generally begins sometime between 8 and 14 years of age. The length of time involved in this evolution is usually 2–4 years. During this time span, puberty is said to occur. Individual variation in the order of appearance of this sequence is great. For example, growth of pubic hair and breast development are not always correlated.

Puberty is due to the reactivation of the hypothalamic-pituitary axis once fully active during the fetal life but suppressed during childhood. If the systems are potentially responsive, what holds function in check until puberty? The hypothalamic-pituitary-gonadal system is operative prior to puberty but is extremely sensitive to sex steroids and, therefore, suppressed. However, the typical “diphasic” pattern of gonadotropin secretion from infancy to puberty results primarily from changing levels of central inhibition of pulsatile GnRH secretion, and to a lesser extent, from a high sensitivity to low levels of gonadal steroid feedback. Negative feedback of steroids cannot be the sole explanation for the low gonadotropin levels in children because agonal children show the same decline in gonadotropins from age 2 to 6 as do normal children.<sup>224</sup> This indicates an intrinsic CNS inhibitory mechanism independent of gonadal steroids. Therefore, the restraint of puberty can be viewed as the result of two forces:

1. A CNS inhibitory force, a mechanism suppressing GnRH pulsatile secretion.
2. A very sensitive negative feedback of gonadal steroids (6–15 times more sensitive before puberty).

Because gonadal children show a rise in gonadotropins at pubertal age following suppression to a nadir during childhood, the dominant mechanism must be a CNS inhibitory force. The initial maturational change in the hypothalamus would then be a decrease in this inhibitory influence. A search for this inhibitory mechanism continues. Some have argued that, rather than a chronic state of inhibition prior to puberty, the GnRH neurons exist in an unrestrained but uncoordinated pattern of activity that prevents adequate secretion.

The pubertal changes result in increasing GnRH pulsatile secretion, leading to increasing gonadotropin production and ovarian stimulation, and finally to increasing estrogen levels. The reason that FSH is the first gonadotropin to rise at puberty is that arcuate activity begins with a low frequency of GnRH pulses. This is associated with a rise in FSH and little change in LH. With acceleration of frequency, FSH and LH reach adult levels. In addition, there is a qualitative change as a greater increase occurs in the bioactive forms of the gonadotropins.

The development of the positive feedback response to estrogen occurs later. This explains the well-known finding of anovulation in the first month (could be as long as 18 months) of menstruation following menarche. There are frequent exceptions, however, and ovulation can occur even at the time of menarche.

Don't think of puberty as being turned on by a controlling center in the brain but rather as a functional confluence of all factors. This is more a concept than an actual locus of action. The overall result of this change in the hypothalamus is the development of secondary sex characteristics, attainment of adult set-point levels, and the ability to reproduce. Neoplastic and vascular disorders that alter hypothalamic sensitivity can reverse the prepubertal threshold restraint and lead to precocious puberty.

# REFERENCES

1. **Dixson A**, The evolution of neuroendocrine mechanisms regulating sexual behaviour in female primates, *Reprod Fertil Dev* 13:599, 2001.
2. **Hayflick JS, Adelman JP, Seeburg PH**, The complete nucleotide sequence of the human gonadotropin-releasing hormone gene, *Nucleic Acids Res* 17:6403, 1989.
3. **Nikolics K, Mason AJ, Szonyi E, Ramachandran J, Seeburg PH**, A prolactin-inhibiting factor within the precursor for human gonadotropin-releasing hormone, *Nature* 316:511, 1985.
4. **Wetsel WC, Srinivasan S**, Psro-GnRH processing, *Prog Brain Res* 141:221, 2002.
5. **Sherwood NM, Lovejoy DA, Coe IR**, Origin of mammalian gonadotropin-releasing hormones, *Endocr Rev* 14:241, 1993.
6. **King JA, Millar RP**, Evolutionary aspects of gonadotropin-releasing-hormone and its receptor, *Cell Mol Neurobiol* 15:5, 1995.
7. **White RB, Eisen JA, Kasten TL, Fernald RD**, Second gene for gonadotropin-releasing hormone in humans, *Proc Natl Acad Sci U S A* 95:305, 1998.
8. **Lee VHY, Lee LTO, Chow BKC**, Gonadotropin-releasing hormone: regulation of the GnRH gene, *FEBS J* 275:5458, 2008.
9. **Tsutsui K, Bentley GE, Ubuka T, Saigoh E, Yin H, Osugi T, Inoue K, Chowdhury VS, Ukena K, Ciccone N, Sharp PJ, Wingfield JC**, The general and comparative biology of gonadotropin-inhibitory hormone (GnIH), *Gen Comp Endocrinol* 153:365, 2007.
10. **Kriegsfeld LJ, Mei DF, Bentley GE, Ubuka T, Mason AO, Inoue K, Ukena K, Tsutsui K, Silver R**, Identification and characterization of a gonadotropin-inhibitory system in the brains of mammals, *Proc Natl Acad Sci* 103:2410, 2006.
11. **Elsholtz HP**, Molecular biology of prolactin: cell-specific and endocrine regulators of the prolactin gene, *Semin Reprod Endocrinol* 10:183, 1992.
12. **Kerr J, Wood W, Ridgway EC**, Basic science and clinical research advances in the pituitary transcription factors: Pit-1 and Prop-1, *Curr Opin Endocrinol Diabetes Obes* 15:359, 2008.
13. **Ikeshita N, Kawagishi M, Shibahara H, Toda K, Yamashita T, Yamamoto D, Sugiyama Y, Iguchi G, Iida K, Takahashi Y, Kaji H, Chihara K, Okimura Y**, Identification and analysis of Prophet of Pit-1-binding sites in human Pit-1 gene, *Endocrinology* 149:5491, 2008.
14. **Kelberman D, Dattani MT**, Hypothalamic and pituitary development: novel insights into the aetiology, *Eur J Endocrinol* 157:S3, 2007.
15. **Radovick S, Nations M, Du Y, Berg LA, Weintraub BD, Wondisford FE**, A mutation in the POU-homeodomain of Pit-1 responsible for combined pituitary hormone deficiency, *Science* 257:1115, 1992.
16. **Pellegrini I, Barlier A, Gunz G, Figarella-Branger D, Enjalbert A, Grisoli F, Jaquet P**, Pit-1 gene expression in the human pituitary and pituitary adenomas, *J Clin Endocrinol Metab* 79:189, 1994.
17. **Xiong F, Chin RA, Hew CL**, A gene encoding chinook salmon (*Oncorhynchus tshawytscha*) prolactin: gene structure and potential cis-acting regulatory elements, *Mol Mar Biol Biotechnol* 1:155, 1992.
18. **Exton MS, Bindert A, Kruger TF, Scheller F, Hartmann U, Schedlowski M**, Cardiovascular and endocrine alterations after masturbation-induced orgasm in women, *Psychosom Med* 61:280, 1999.
19. **Exton MS, Kruger TH, Koch M, Paulson E, Knapp W, Hartmann U, Schedlowski M**, Coitus-induced orgasm stimulates prolactin secretion in healthy subjects, *Psychoneuroendocrinology* 26:287, 2001.
20. **Ben-Jonathan N, Hnasko R**, Dopamine as a prolactin (PRL) inhibitor, *Endocr Rev* 22:724, 2001.
21. **Arden KC, Boutin JM, Djiane J, Kelly PA, Cavenee WK**, The receptors for prolactin and growth hormone are localized in the same region of human chromosome 5, *Cytogenet Cell Genet* 53:161, 1990.
22. **Melmed S**, The structure and function of pituitary dopamine receptors, *Endocrinologist* 7:385, 1997.
23. **Schwanzel-Fukuda M, Pfaff DW**, Origin of luteinizing hormone-releasing hormone neurons, *Nature* 338:161, 1989.
24. **Ronnekleiv OK, Resko JA**, Ontogeny of gonadotropin-releasing hormone-containing neurons in early fetal

- development of rhesus macaques, *Endocrinology* 126:498, 1990.
25. **Waldstreicher J, Seminara SB, Jameson JL, Geyer A, Nachtigall LB, Boepple PA, Holmes LB, Crowley WF Jr**, The genetic and clinical heterogeneity of gonadotropin-releasing hormone deficiency in the human, *J Clin Endocrinol Metab* 81:4388, 1996.
  26. **Bick D, Franco B, Sherin RJ, Heye B, Pike L, Crawford J, Maddalena A, Incerti B, Pragliola A, Meitinger T, Ballabio A**, Brief report: intragenic deletion of the KALIG-1 gene in Kallmann's syndrome, *N Engl J Med* 326:1752, 1992.
  27. **Hardelin J-P, Levilliers J, Young J, Pholsena M, Legouis R, Kirk J, Boulooux P, Petit C, Schaison G**, Xp22.3 deletions in isolated familial Kallmann's syndrome, *J Clin Endocrinol Metab* 76:827, 1993.
  28. **Trarbach EB, Silveira LG, Latronico AC**, Genetic insights into human isolated gonadotropin deficiency, *Pituitary* 10:381, 2007.
  29. **Pierce A, Bliesner B, Xu M, Nielsen-Preiss S, Lemke G, Tobet S, Wierman ME**, Axl and Tyro3 modulate female reproduction by influencing gonadotropin-releasing hormone neuron survival and migration, *Mol Endocrinol* 22:2481, 2008.
  30. **Jennes L, Stumpf WE, Sheedy ME**, Ultrastructural characterization of gonadotropin-releasing hormone (GnRH)-producing neurons, *J Comp Neurol* 232:543, 1985.
  31. **Stern K, McClintock MK**, Regulation of ovulation by human pheromones, *Nature* 392:177, 1998.
  32. **McClintock MK**, Menstrual synchrony and suppression, *Nature* 229:244, 1971.
  33. **Matteo S**, The effect of job stress and job interdependency on menstrual cycle length, regularity and synchrony, *Psychoneuroendocrinology* 12:467, 1987.
  34. **Weller A, Weller L**, The impact of social interaction factors on menstrual synchrony in the workplace, *Psychoneuroendocrinology* 20:21, 1995.
  35. **Weller A, Weller L**, Menstrual synchrony under optimal conditions: Bedouin families, *J Comp Psychol* 111:143, 1997.
  36. **Weller L, Weller A, Roizman S**, Human menstrual synchrony in families and among close friends: examining the importance of mutual exposure, *J Comp Psychol* 113:261, 1999.
  37. **Schank JC**, A multitude of errors in menstrual-synchrony research: replies to Weller and Weller (2002) and Graham (2002), *J Comp Psychol* 116:319, 2002.
  38. **Silverman AJ, Antunes JL, Abrams G, Nilaver G, Thau R, Robinson JA, Ferin M, Krey LC**, The luteinizing hormone-releasing pathways in the rhesus (macaca mulatta) and pigtailed (*Macaca nemestrina*) monkeys: new observations using thick unembedded sections, *J Comp Neurol* 211:309, 1982.
  39. **Silverman AJ, Jhamandas J, Renaud LP**, Localization of luteinizing hormone-releasing hormone (LHRH) neurons that project to the median eminence, *J Neurosci* 7:2312, 1987.
  40. **Goldsmith PC, Thind KK, Song T, Kim EJ, Boggan JE**, Location of the neuroendocrine gonadotropin-releasing hormone neurons in the monkey hypothalamus by retrograde tracing and immunostaining, *J Neuroendocrinol* 2:157, 1990.
  41. **Nakai Y, Plant TM, Hess DL, Keogh EJ, Knobil E**, On the sites of the negative and positive feedback actions of estradiol in the control of gonadotropin secretion in the rhesus monkey, *Endocrinology* 102:1008, 1978.
  42. **Knobil E**, The neuroendocrine control of the menstrual cycle, *Recent Prog Horm Res* 36:53, 1980.
  43. **Haisenleder DJ, Dalkin AC, Ortolano GA, Marshall JC, Shupnik MA**, A pulsatile gonadotropin-releasing hormone stimulus is required to increase transcription of the gonadotropin subunit genes: evidence for differential regulation of transcription by pulse frequency in vivo, *Endocrinology* 128:509, 1991.
  44. **Van Vugt DA, Diefenbach WP, Ferin M**, Gonadotropin-releasing hormone pulses in third ventricular cerebrospinal fluid of ovariectomized rhesus monkeys: correlation with luteinizing hormone pulses, *Endocrinology* 117:1550, 1985.
  45. **Gross KM, Matsumoto AM, Southworth MB, Bremner WJ**, Evidence for decreased luteinizing hormone-releasing hormone frequency in men with selective elevations of follicle-stimulating hormone, *J Clin Endocrinol Metab* 60:197, 1985.
  46. **Backstrom CT, McNeilly AL, Leask RM, Baird DT**, Pulsatile secretion of LH, FSH, prolactin, oestradiol

and progesterone during the human menstrual cycle, *Clin Endocrinol (Oxf)* 16:29, 1982.

47. **Marshall JC, Dalkin AC, Haisenleder DJ, Paul SJ, Ortolano GA, Kelsch RP**, Gonadotropin-releasing hormone pulses: regulators of gonadotropin synthesis and ovulatory cycles, *Recent Prog Horm Res* 47:155, 1991.
48. **Reame N, Sauder SE, Kelch RP, Marshall JC**, Pulsatile gonadotropin secretion during the human menstrual cycle: evidence for altered frequency of gonadotropin-releasing hormone secretion, *J Clin Endocrinol Metab* 59:328, 1984.
49. **Filicori M, Santoro N, Merriam GR, Crowley WF Jr**, Characterization of the physiological pattern of episodic gonadotropin secretion throughout the human menstrual cycle, *J Clin Endocrinol Metab* 62:1136, 1986.
50. **Hall JE, Schoenfeld DA, Martin KA, Crowley WF Jr**, Hypothalamic gonadotropin-releasing hormone secretion and follicle-stimulating hormone dynamics during the luteal-follicular transition, *J Clin Endocrinol Metab* 74:600, 1992.
51. **McCartney CR, Gingrich MB, Hu Y, Evans WS, Marshall JC**, Hypothalamic regulation of cyclic ovulation: evidence that the increase in gonadotropin-releasing hormone pulse frequency during the follicular phase reflects the gradual loss of the restraining effects of progesterone, *J Clin Endocrinol Metab* 87:2194, 2002.
52. **Veldhuis JD, Evans WS, Johnson ML, Wills MR, Rogol AD**, Physiological properties of the luteinizing hormone pulse signal: impact of intensive and extended venous sampling paradigms on its characterization in healthy men and women, *J Clin Endocrinol Metab* 62:881, 1986.
53. **Ferris HA, Shupnik MA**, Mechanisms for pulsatile regulation of the gonadotropin subunit genes by GnRH1, *Biol Reprod* 74:993, 2006.
54. **Rossmannith WG, Gambacciani M**, Autonomous gonadotropin release from the human pituitary in vitro and factors influencing this secretion, *Gynecol Endocrinol* 8:265, 1994.
55. **Leclerc GM, Boockfor FR**, Identification of a novel OCT1 binding site that is necessary for the elaboration of pulses of rat GnRH promoter activity, *Mol Cell Endocrinol* 245:86, 2005.
56. **Stojilkovic SS, Krsmanovic LZ, Spergel DJ, Catt KJ**, GnRH neurons: intrinsic pulsatility and receptor-mediated regulation, *Trends Endocrinol Metab* 5:201, 1994.
57. **Andersen AN, Hagen C, Lange P, Boesgaard S, Djursing H, Eldrup E, Micic S**, Dopaminergic regulation of gonadotropin levels and pulsatility in normal women, *Fertil Steril* 47:391, 1987.
58. **Herbison AE**, Noradrenergic regulation of cyclic GnRH secretion, *Rev Reprod* 2:1, 1997.
59. **Sahu A, Phelps CP, White JD, Crowley WR, Kalra SP, Kalra PS**, Steroidal regulation of hypothalamic neuropeptide Y release and gene expression, *Endocrinology* 130:3331, 1992.
60. **Pau KF, Berria M, Hess DL, Spies HG**, Hypothalamic site-dependent effects of neuropeptide Y on gonadotropin-releasing hormone secretion in rhesus macaques, *J Neuroendocrinol* 7:63, 1995.
61. **Kaye WH, Berrettini W, Gwirtsman H, George DT**, Altered cerebrospinal fluid neuropeptide Y and peptide YY immunoreactivity in anorexia and bulimia nervosa, *Arch Gen Psychiatry* 47:548, 1990.
62. **McShane TM, May T, Miner JL, Keisler DH**, Central actions of neuropeptide-Y may provide a neuromodulatory link between nutrition and reproduction, *Biol Reprod* 46:1151, 1992.
63. **Seminara SB, Messenger S, Chatzidaki EE, Thresher RR, Acierno JS Jr, Shagoury JK, Bo-Abbas Y, Kuohung W, Schwino KM, Hendrick AG, Zahn D, Dixon J, Kaiser UB, Slaughaupt SA, Gusella JF, O'Rahilly S, Carlton MB, Crowley WF Jr, Aparicio SA, Colledge WH**, The GPR54 gene as a regulator of puberty, *N Engl J Med* 349:1614, 2003.
64. **Quaynor S, Hu L, Feng H, Mores N, Krsmanovic LZ, Catt KJ**, Expression of a functional G protein-coupled receptor 54-kisspeptin autoregulatory system in hypothalamic gonadotropin-releasing hormone neurons, *Mol Endocrinol* 21:3062, 2007.
65. **Clarkson J, d'Anglemont de Tassigny X, Moreno AS, Colledge WH, Herbison AE**, Kisspeptin-GPR54 signaling is essential for preovulatory gonadotropin-releasing hormone neuron activation and the luteinizing hormone surge, *J Neurosci* 28:8691, 2008.
66. **Birken S, Maydelman Y, Gawinowicz MA, Pound A, Liu Y, Hartree AS**, Isolation and characterization of human pituitary chorionic gonadotropin, *Endocrinology* 137:1402, 1996.

67. **Patton PE, Hess DL, Cook DM, Loriaux DL, Braunstein GD**, Human chorionic gonadotropin production by the pituitary gland in a premenopausal women, *Am J Obstet Gynecol* 178:1138, 1998.
68. **Ravindra R, Aronstam RS**, Progesterone, testosterone, and estradiol-17 $\beta$  inhibit gonadotropin-releasing hormone stimulation of G protein GTPase activity in plasma membranes from rat anterior pituitary lobe, *Acta Endocrinol* 126:345, 1992.
69. **Tse A, Hille B**, GnRH-induced Ca<sup>2+</sup> oscillations and rhythmic hyperpolarizations of pituitary gonadotropes, *Science* 255:462, 1992.
70. **Haisenleder DJ, Burger LL, Walsh HE, Stevens J, Aylor KW, Shupnik MA, Marshall JC**, Pulsatile gonadotropin-releasing hormone stimulation of gonadotropin subunit transcription in rat pituitaries: evidence for the involvement of Jun N-terminal kinase but not p38, *Endocrinology* 149:139, 2008.
71. **Kaiser UB, Dushkin H, Altherr MR, Beier DR, Chion WW**, Chromosomal localization of the gonadotropin-releasing hormone receptor gene to human chromosome 4q13.1-q21.1 and mouse chromosome 5, *Genomics* 20:506, 1994.
72. **Sealfon SC, Weinstein H, Millar RP**, Molecular mechanisms of ligand interaction with the gonadotropin-releasing hormone receptor, *Endocr Rev* 18:180, 1997.
73. **Millar R, Lowe S, Conklin D, Pawson A, Maudsley S, Troskie B, Ott T, Millar M, Lincoln G, Sellar R, Faurholm B, Scobie G, Kuestner R, Terasawa E, Katz A**, A novel mammalian receptor for the evolutionarily conserved type II GnRH, *Proc Natl Acad Sci U S A* 98:9636, 2001.
74. **Kaiser UB, Conn PM, Chin WW**, Studies of gonadotropin-releasing hormone (GnRH) action using GnRH receptor-expressing pituitary cell lines, *Endocr Rev* 18:46, 1997.
75. **Ray D, Melmed S**, Pituitary cytokine and growth factor expression and action, *Endocr Rev* 18:206, 1997.
76. **Evans JJ**, Modulation of gonadotropin levels by peptides acting at the anterior pituitary gland, *Endocr Rev* 20:46, 1999.
77. **Winters SJ, Moore JP**, Paracrine control of gonadotrophs, *Semin Reprod Med* 25:379, 2007.
78. **Risbridger GP, Schmitt JF, Robertson DM**, Activins and inhibins in endocrine and other tumors, *Endocr Rev* 22:836, 2001.
79. **Roberts V, Meunier H, Vaughan J, Rivier J, Rivier C, Vale W, Sawchenko P**, Production and regulation of inhibin subunits in pituitary gonadotropes, *Endocrinology* 124:552, 1989.
80. **Bauer-Dantoin AC, Wess J, Jameson JL**, Roles of estrogen, progesterone, and gonadotropin-releasing hormone (GnRH) in the control of pituitary GnRH receptor gene expression at the time of the preovulatory gonadotropin surges, *Endocrinology* 136:1014, 1995.
81. **Blumenfeld Z**, Response of human fetal pituitary cells to activin, inhibin, hypophysiotropic and neuroregulatory factors in vitro, *Early Pregnancy* 5:41, 2001.
82. **Fang J, Yin W, Smiley E, Wang SQ, Bonadio J**, Genes coding for mouse activin bC and bE are closely linked and exhibit a liver-specific expression pattern in adult tissues, *Biochem Biophys Res Commun* 231:655, 1997.
83. **Lau AL, Kumar TR, Nishimori K, Bonadio J, Matzuk MM**, Activin bC and bE genes are not essential for mouse liver growth, differentiation, and regeneration, *Mol Cell Biol* 20:6127, 2000.
84. **Kitaoka M, Kojima I, Ogata E**, Activin-A: a modulator of multiple types of anterior pituitary cells, *Biochem Biophys Res Commun* 157:48, 1988.
85. **Billestrup N, Gonzalez-Manchon C, Potter E, Vale W**, Inhibition of somatotroph growth and growth hormone biosynthesis by activin in vitro, *Mol Endocrinol* 4:356, 1990.
86. **Corrigan AZ, Bilezikjian LM, Carroll RS, Bald LN, Schmelzer CH, Fendly BM, Mason AJ, Chin WW, Schwall RH, Vale W**, Evidence for an autocrine role of activin B within rat anterior pituitary cultures, *Endocrinology* 128:1682, 1991.
87. **Norwitz ER, Xu S, Jeong KH, Bedecarrats GY, Winebrenner LD, Chin WW, Kaiser UB**, Activin A augments GnRH-mediated transcriptional activation of the mouse GnRH receptor gene, *Endocrinology* 143:985, 2002.
88. **Bilezikjian LM, Corrigan AZ, Blount AL, Vale WW**, Pituitary follistatin and inhibin subunit messenger ribonucleic acid levels are differentially regulated by local and hormonal factors, *Endocrinology* 137:4277, 1996.

89. **Kaiser UB, Lee BL, Carroll RS, Unabia G, Chin WW, Childs GV**, Follistatin gene expression in the pituitary: localization in gonadotrophs and folliculostellate cells in diestrous rats, *Endocrinology* 130:3048, 1992.
90. **Kogawa K, Nakamura T, Sugiono K, Takio K, Titani K, Sugino H**, Activin-binding protein is present in pituitary, *Endocrinology* 128:1434, 1991.
91. **Besecke LM, Guendner MJ, Sluss PA, Polak AG, Woodruff TK, Jameson JL, Bauer-Dantoin AC, Weiss J**, Pituitary follistatin regulates activin-mediated production of follicle-stimulating hormone during the rat estrous cycle, *Endocrinology* 138:2841, 1997.
92. **Besecke LM, Guendner MJ, Schneyer AL, Bauer-Dantoin AC, Jameson JL, Weiss J**, Gonadotropin-releasing hormone regulates follicle-stimulating hormone- $\beta$  gene expression through an activin/follistatin autocrine or paracrine loop, *Endocrinology* 137:3667, 1996.
93. **Pernasetti F, Vasilyev VV, Rosenberg SB, Bailey JS, Huang HJ, Miller WL, Mellon PL**, Cell-specific transcriptional regulation of follicle-stimulating hormone- $\beta$  by activin and gonadotropin-releasing hormone in the L $\beta$ T2 pituitary gonadotrope cell model, *Endocrinology* 142:2284, 2001.
94. **Burger LL, Dalkin AC, Aylor KW, Haisenleder DJ, Marshall JC**, GnRH pulse frequency modulation of gonadotropin subunit gene transcription in normal gonadotropes—assessment by primary transcript assay provides evidence for roles of GnRH and follistatin, *Endocrinology* 143:3243, 2002.
95. **Wang Y, Fortin J, Lamba P, Bonomi M, Persani L, Roberson MS, Bernard DJ**, Activator protein-1 and Smad proteins synergistically regulate human follicle-stimulating hormone  $\beta$ -promoter activity, *Endocrinology* 149:5577, 2008.
96. **Howlett TA, Rees LH**, Endogenous opioid peptides and hypothalamo-pituitary function, *Annu Rev Physiol* 48:527, 1986.
97. **Bacchinetti F, Petraglia F, Genazzani AR**, Localization and expression of the three opioid systems, *Semin Reprod Endocrinol* 5:103, 1987.
98. **Micevych PE, Eckersell CB, Brecha N, Holland KL**, Estrogen modulation of opioid and cholecystokinin systems in the limbic-hypothalamic circuit, *Brain Res Bull* 44:335, 1997.
99. **Gindoff PR, Ferin M**, Brain opioid peptides and menstrual cyclicality, *Semin Reprod Endocrinol* 5:125, 1987.
100. **Rabinovici J, Rothman P, Monroe SE, Nerenberg C, Jaffe RB**, Endocrine effects and pharmacokinetic characteristics of a potent new gonadotropin-releasing hormone antagonist (Ganirelix) with minimal histamine-releasing properties: studies in postmenopausal women, *J Clin Endocrinol Metab* 75:1220, 1992.
101. **Shoupe D, Montz FJ, Lobo RA**, The effects of estrogen and progestin on endogenous opioid activity in oophorectomized women, *J Clin Endocrinol Metab* 60:178, 1985.
102. **Casper RF, Alapin-Rubilovitz S**, Progestins increase endogenous opioid peptide activity in postmenopausal women, *J Clin Endocrinol Metab* 60:34, 1985.
103. **Marunicic M, Casper RF**, The effect of luteal phase estrogen antagonism on luteinizing hormone pulsatility and luteal function in women, *J Clin Endocrinol Metab* 64:148, 1987.
104. **Kletter GB, Padmanaghan V, Beitins IZ, Marshall JC, Kelch RP, Foster CM**, Acute effects of estradiol infusion and naloxone on luteinizing hormone secretion in pubertal boys, *J Clin Endocrinol Metab* 82:4010, 1997.
105. **Cemeroglu AP, Kletter GB, Guo W, Brown MB, Kelch RP, Marshall JC, Padmanabhan V, Foster CM**, In pubertal girls, naloxone fails to reverse the suppression of luteinizing hormone secretion by estradiol, *J Clin Endocrinol Metab* 83:3501, 1998.
106. **Goodman RL, Parfitt DB, Evans NP, Dahl GE, Karsch FJ**, Endogenous opioid peptides control the amplitude and shape of gonadotropin-releasing hormone pulses in the ewe, *Endocrinology* 136:2412, 1995.
107. **Goodman RL, Gibson M, Skinner DC, Lehman MN**, Neuroendocrine control of pulsatile GnRH secretion during the ovarian cycle: evidence from the ewe, *Reprod Suppl* 59:41, 2002.
108. **Mateo AR, Hammer RP**, Dynamic pattern of medial preoptic  $\mu$ -opiate receptor regulation by gonadal steroid hormones, *Neuroendocrinology* 55:51, 1992.
109. **Weiland NG, Wise PM**, Estrogen and progesterone regulate opiate receptor densities in multiple brain regions, *Endocrinology* 126:804, 1990.
110. **Petersen SL, Keller ML, Carder SA, McCrone S**, Differential effects of estrogen and progesterone on



- levels of POMC mRNA levels in the arcuate nucleus: relationship to the timing of LH surge release, *J Neuroendocrinol* 5: 643, 1993.
111. **Shalts E, Feng Y-J, Ferin M, Wardlaw SL**, Alpha-Melanocyte-stimulating hormone antagonizes the neuroendocrine effects of corticotropin-releasing factor and interleukin-1 in the primate, *Endocrinology* 131:132, 1992.
  112. **Petraglia F, D'Ambrogio G, Comitini G, Facchinetti F, Volpe A, Genazzani AR**, Impairment of opioid control of luteinizing hormone secretion in menstrual disorders, *Fertil Steril* 43:534, 1985.
  113. **Khoury SA, Reame NE, Kelch RP, Marshall JC**, Diurnal patterns of pulsatile luteinizing hormone secretion in hypothalamic amenorrhea: reproducibility and responses to opiate blockade and  $\alpha_2$ -adrenergic agonist, *J Clin Endocrinol Metab* 64:755, 1987.
  114. **Wildt L, Leyendecker G, Sir-Petermann T, Waibel-Treber S**, Treatment with naltrexone in hypothalamic ovarian failure: induction of ovulation and pregnancy, *Hum Reprod* 8:350, 1993.
  115. **Suh BY, Liu JH, Berga SL, Quigley ME, Laughlin GA, Yen SSC**, Hypercortisolism in patients with functional hypothalamic amenorrhea, *J Clin Endocrinol Metab* 66:733, 1988.
  116. **Veldhuis JD, Johnson ML, Seneta E, Iranmanesh A**, Temporal coupling among luteinizing hormone, follicle stimulating hormone,  $\beta$ -endorphin and cortisol pulse episodes in vivo, *Acta Endocrinol* 126:193, 1992.
  117. **Vamvakopoulos NC, Chrousos GP**, Evidence of direct estrogenic regulation of human corticotropin-releasing hormone gene expression. Potential implications for the sexual dimorphism of the stress response and immune/inflammatory reaction. *J Clin Invest* 92:1896, 1993.
  118. **Breen KM, Davis TL, Doro LC, Nett TM, Oakley AE, Padmanabhan V, Rispoli LA, Wagenmaker ER, Karsch FJ**, Insight into the neuroendocrine site and cellular mechanism by which cortisol suppresses pituitary responsiveness to gonadotropin-releasing hormone, *Endocrinology* 149:767, 2008.
  119. **Cumming DC, Wheeler GD**, Opioids in exercise physiology, *Semin Reprod Endocrinol* 5:171, 1987.
  120. **Sarkar DK, Yen SSC**, Hyperprolactinemia decreases the luteinizing hormone-releasing hormone concentration in pituitary portal plasma: a possible role for  $\beta$ -endorphin as a mediator, *Endocrinology* 116:2080, 1985.
  121. **Chen CC, Chang C, Krieger DT, Bardin CW**, Expression and regulation of proopiomelanocortin-like gene in the ovary and placenta: comparison with the testis, *Endocrinology* 118:2382, 1986.
  122. **Petraglia F, Di Meo G, Storchi R, Segre A, Facchinetti F, Szalay S, Volpe A, Genazzani AR**, Proopiomelanocortin-related peptides and methionine enkephalin in human follicular fluid: changes during the menstrual cycle, *Am J Obstet Gynecol* 157:142, 1987.
  123. **Fishman J, Norton B**, Brain catecholestrogens: formation and possible functions, *Adv Biosci* 15:123, 1975.
  124. **Mais V, Kazer RR, Cetel NS, Rivier J, Vale W, Yen SSC**, The dependency of folliculogenesis and corpus luteum function on pulsatile gonadotropin secretion in cycling women using a gonadotropin-releasing hormone antagonist as a probe, *J Clin Endocrinol Metab* 62:1250, 1986.
  125. **Brownstein MJ, Russel JT, Gainer H**, Synthesis, transport, and release of posterior pituitary hormones, *Science* 207:373, 1980.
  126. **Mohr E, Meyerhof W, Richter D**, The hypothalamic hormone oxytocin: from gene expression to signal transduction, *Rev Physiol Biochem Pharmacol* 121:31, 1992.
  127. **Acher R, Chauvet J, Rouille Y**, Dynamic processing of neuropeptides: sequential conformation shaping of neurohypophysial preprohormones during intraneuronal secretory transport, *J Mol Neurosci* 18:223, 2002.
  128. **Christensen JH, Siggaard C, Corydon TJ, deSanctis L, Kovacs L, Robertson GL, Gregersen N, Rittig S**, Six novel mutations in the arginine vasopressin gene in 15 kindreds with autosomal dominant familial neurohypophysial diabetes insipidus give further insight into the pathogenesis, *Eur J Hum Genet* 12:44, 2004.
  129. **Kasson BG, Adashi EY, Hsueh AJW**, Arginine vasopressin in the testis: an intragonadal peptide control system, *Endocr Rev* 7:156, 1986.
  130. **Perlow MJ, Reppert SM, Artman HA, Fisher DA, Seif SM, Robinson AG**, Oxytocin, vasopressin and estrogen-stimulated neurophysin: daily patterns of concentration in cerebrospinal fluid, *Science* 216:1416, 1983.
  131. **Amico JA, Seif SM, Robinson AG**, Elevation of oxytocin and the oxytocin-associated neurophysin in the plasma of normal women during midcycle, *J Clin Endocrinol Metab* 53:1229, 1981.
  132. **Hrabovszky E, Kallo I, Hajszan T, Shughrue PJ, Merchenthaler I, Liposits Z**, Expression of estrogen

receptor-beta messenger ribonucleic acid in oxytocin and vasopressin neurons of the rat supraoptic and paraventricular nuclei, *Endocrinology* 139:2600, 1998.

133. **Vincent J-L**, Physiology and pathophysiology of the vasopressinergic system, *Best Pract Res Clin Anaesthesiol* 22:243, 2009.
134. **Carmichael MS, Warburton VL, Dixen J, Davidson JM**, Relationships among cardiovascular, muscular, and oxytocin responses during human sexual activity, *Arch Sex Behav* 23:59, 1994.
135. **Sabatier N, Rowe I, Leng G**, Central release of oxytocin and the ventromedial hypothalamus, *Biochem Soc Trans* 35:1247, 2007.
136. **Hirst JJ, Chibbart R, Mitchell BF**, Role of oxytocin in the regulation of uterine activity during pregnancy and in the initiation of labor, *Semin Reprod Endocrinol* 11:219, 1993.
137. **Hirst JJ, Haluska GJ, Cook MJ, Novy MJ**, Plasma oxytocin and nocturnal uterine activity: maternal but not fetal concentrations increase progressively during late pregnancy and delivery in Rhesus monkeys, *Am J Obstet Gynecol* 169: 415, 1993.
138. **Wilson T, Liggins GC, Whittaker DJ**, Oxytocin stimulates the release of arachidonic acid and prostaglandin F<sub>2a</sub> from human decidual cells, *Prostaglandins* 35:771, 1988.
139. **Zeeman GG, Khan-Dawood FS, Dawood MY**, Oxytocin and its receptor in pregnancy and parturition: current concepts and clinical implications, *Obstet Gynecol* 89:873, 1997.
140. **Ferin M, Rosenblatt H, Carmel PW, Antunes JL, Vande Wiele RL**, Estrogen-induced gonadotropin surges in female rhesus monkeys after pituitary stalk section, *Endocrinology* 104:50, 1979.
141. **Yen SSC, Lein A**, The apparent paradox of the negative and positive feedback control system on gonadotropin secretion, *Am J Obstet Gynecol* 126:942, 1976.
142. **Hoff JD, Lasley BL, Yen SSC**, The functional relationship between priming and releasing actions of luteinizing hormone-releasing hormone, *J Clin Endocrinol Metab* 49:8, 1979.
143. **Urban RJ, Veldhuis JD, Dufau ML**, Estrogen regulates the gonadotropin-releasing hormone-stimulated secretion of biologically active luteinizing hormone, *J Clin Endocrinol Metab* 72:660, 1991.
144. **Gregg DW, Nett TM**, Direct effects of estradiol-17 $\beta$  on the number of gonadotropin-releasing hormone receptors in ovine pituitary, *Biol Reprod* 40:288, 1989.
145. **Adams TE, Norman RL, Spies HG**, Gonadotropin-releasing hormone receptor binding and pituitary responsiveness in estradiol-primed monkeys, *Science* 213:1388, 1981.
146. **Menon M, Peegel H, Katta V**, Estradiol potentiation of gonadotropin-releasing hormone responsiveness in the anterior pituitary is mediated by an increase in gonadotropin-releasing hormone receptors, *Am J Obstet Gynecol* 151:534, 1985.
147. **Herbison AE**, Multimodal influence of estrogen upon gonadotropin-releasing hormone neurons, *Endocr Rev* 19:302, 1998.
148. **Baratta M, West LA, Turzillo AM, Nett TM**, Activin modulates differential effects of estradiol on synthesis and secretion of follicle-stimulating hormone in ovine pituitary cells, *Biol Reprod* 64:714, 2001.
149. **Miller CD, Miller WL**, Transcriptional repression of the ovine follicle-stimulating hormone-beta gene by 17 beta-estradiol, *Endocrinology* 137:3437, 1996.
150. **Leroy I, d'Acremont MF, Brailly-Tabard S, Frydman R, de Mouzon J, Bouchard P**, A single injection of a gonadotropin-releasing hormone (GnRH) antagonist (Cetrorelix) postpones the luteinizing hormone (LH) surge: further evidence for the role of GnRH during the LH surge, *Fertil Steril* 62: 461, 1994.
151. **Pau KF, Berria M, Hess DL, Spies HG**, Preovulatory gonadotropin-releasing hormone surge in ovarian-intact rhesus macaques, *Endocrinology* 133:1650, 1993.
152. **Xia L, Van Vugt D, Alston EJ, Luckhaus J, Ferin M**, A surge of gonadotropin-releasing hormone accompanies the estradiol-induced gonadotropin surge in the Rhesus monkey, *Endocrinology* 131:2812, 1992.
153. **Woller MJ, Terasawa E**, Changes in pulsatile release of neuropeptide-Y and luteinizing hormone (LH)-releasing hormone during the progesterone-induced LH surge in rhesus monkeys, *Endocrinology* 135:1679, 1994.
154. **Welt CK, Pagan YL, Smith PC, Rado KB, Hall JE**, Control of follicle-stimulating hormone by estradiol and the inhibins: critical role of estradiol at the hypothalamus during the luteal-follicular transition, *J Clin Endocrinol*

Metab 88:1766, 2003.

155. **El Majdoubi M, Sahu A, Plant TM**, Effect of estrogen on hypothalamic transforming growth factor alpha and gonadotropin-releasing hormone gene expression in the female rhesus monkey, *Neuroendocrinology* 67:228, 1998.
156. **Shupnik MA, Weinmann CM, Notides AC, Chin WW**, An upstream region of the rat luteinizing hormone b gene binds estrogen receptor and confers estrogen responsiveness, *J Biol Chem* 264:80, 1989.
157. **Shivers BD, Harlan RE, Morrell JI, Pfaff DW**, Absence of estradiol concentration in cell nuclei of LHRH-immunoreactive neurons, *Nature* 304:345, 1983.
158. **Herbison AE, Horvath TL, Naftolin F, Leranath C**, Distribution of estrogen receptor-immunoreactive cells in monkey hypothalamus: relationship to neurons containing luteinizing hormone-releasing hormone and tyrosine hydroxylase, *Neuroendocrinology* 61:1, 1995.
159. **Sullivan K, Witkin JW, Ferin M, Silverman AJ**, GnRH neurons in the rhesus macaque are not immunoreactive for the estrogen receptor, *Brain Res* 685:198, 1995.
160. **Hrabovszky E, Shughrue PJ, Merchenthaler I, Hajszán T, Carpenter CD, Liposits Z, Petersen SL**, Detection of estrogen receptor-b messenger ribonucleic acid and 125I-estrogen binding sites in luteinizing hormone-releasing hormone neurons of the rat brain, *Endocrinology* 141:3506, 2000.
161. **Kalló I, Butler JA, Barkovics-Kalló M, Goubillon M-L, Coen CW**, Oestrogen receptor b-immunoreactivity in gonadotropin releasing hormone-expressing neurons: regulation by oestrogen, *J Neuroendocrinol* 13:741, 2001.
162. **Abraham IM, Han SK, Todman MG, Korach KS, Herbison AE**, Estrogen receptor beta mediates rapid estrogen actions on gonadotropin-releasing hormone neurons in vivo, *J Neurosci* 23:5771, 2003.
163. **Skynner MJ, Sim JA, Herbison AE**, Detection of estrogen receptor alpha and beta messenger ribonucleic acids in adult gonadotropin-releasing hormone neurons, *Endocrinology* 140:5195, 1999.
164. **Dorling AA, Todman MG, Korach KS, Herbison AE**, Critical role for estrogen receptor alpha in negative feedback regulation of gonadotropin-releasing hormone mRNA expression in the female mouse, *Neuroendocrinology* 78:204, 2003.
165. **Hu L, Gustofson RL, Feng H, Leung PK, Mores N, Krsmanovic LZ, Catt KJ**, Converse regulatory functions of estrogen receptor-a and -b subtypes expressed in hypothalamic gonadotropin-releasing hormone neurons, *Mol Endocrinol* 22:2250, 2008.
166. **Radovick S, Ticknor CM, Nakayama Y, Notides AC, Rahman A, Weintraub BD, Cutler GB Jr, Wondisford FE**, Evidence for direct estrogen regulation of the human gonadotropin-releasing hormone gene, *J Clin Invest* 88:1649, 1991.
167. **Chen A, Zi K, Laskar-Levy O, Koch Y**, The transcription of the hGnRH-I and hGnRH-II genes in human neuronal cells is differentially regulated by estrogen, *J Mol Neurosci* 18:67, 2002.
168. **Evans NP, Dahl GE, Mauger D, Karsch FJ**, Estradiol induces qualitative and quantitative changes in the pattern of gonadotropin-releasing hormone secretion during the pre-surge period in the ewe, *Endocrinology* 136:1603, 1995.
169. **Evans NP, Dahl GE, Mauger DT, Padmanabhan V, Thrun LA, Karsch FJ**, Does estradiol induce the preovulatory gonadotropin-releasing hormone (GnRH) surge in the ewe by inducing a progressive change in the mode of operation of the GnRH neurosecretory system?, *Endocrinology* 136:5511, 1995.
170. **Bowen JM, Dahl GE, Evans NP, Thrun LA, Wang Y, Brown MB, Karsch FJ**, Importance of the gonadotropin-releasing hormone (GnRH) surge for induction of the preovulatory luteinizing hormone surge of the ewe: dose-response relationship and excess of GnRH, *Endocrinology* 139:588, 1998.
171. **Krajewski SJ, Abel TW, Voytko ML, Rance NE**, Ovarian steroids differentially modulate the gene expression of gonadotropin-releasing hormone neuronal subtypes in the ovariectomized cynomolgus monkey, *J Clin Endocrinol Metab* 88:655, 2003.
172. **Naftolin F, Garcia-Segura LM, Horvath TL, Axarnovszky A, Demir N, Fadiel A, Leranath C, Vondracek-Klepper S, Lewis C, Chang A, Parducz A**, Estrogen-induced hypothalamic synaptic plasticity and pituitary sensitization in the control of the estrogen-induced gonadotrophin surge, *Reprod Sci* 14:101, 2007.
173. **Katt JA, Duncan JA, Herbon L, Barkan A, Marshall JC**, The frequency of gonadotropin-releasing

- hormone stimulation determines the number of pituitary gonadotropin-releasing hormone receptors, *Endocrinology* 116:2113, 1985.
174. **Moenter SM, Brand RC, Karsch FJ**, Dynamics of gonadotropin-releasing hormone (GnRH) secretion during the GnRH surge: insights into the mechanism of GnRH surge induction, *Endocrinology* 130:2978, 1992.
  175. **Bertram R, Li Y-X**, A mathematical model for the actions of activin, inhibin, and follistatin on pituitary gonadotrophs, *Bull Math Biol* 70:2211, 2008.
  176. **Marut EL, Williams RF, Cowan BD, Lynch A, Lerner SP, Hodgen GD**, Pulsatile pituitary gonadotropin secretion during maturation of the dominant follicle in monkeys: estrogen positive feedback enhances the biological activity of LH, *Endocrinology* 109:2270, 1981.
  177. **Anobile CJ, Talbot JA, McCann SJ, Padmanabhan V, Robertson WR**, Glycoform composition of serum gonadotrophins through the normal menstrual cycle and in the post-menopausal state, *Mol Hum Reprod* 4:631, 1998.
  178. **Zariñán T, Olivares A, Söderlund D, Méndez JP, Ulloa-Aguirre A**, Changes in the biological: immunological ratio of basal and GnRH-releasable FSH during the follicular, pre-ovulatory and luteal phases of the human menstrual cycle, *Hum Reprod* 16:1611, 2001.
  179. **Liu JH, Yen SSC**, Induction of midcycle gonadotropin surge by ovarian steroids in women: a critical evaluation, *J Clin Endocrinol Metab* 57:797, 1983.
  180. **Collins RL, Hodgen GD**, Blockade of the spontaneous midcycle gonadotropin surge in monkeys by RU 486: a progesterone antagonist or agonist?, *J Clin Endocrinol Metab* 63:1270, 1986.
  181. **Turgeon JL, Waring DW**, The timing of progesterone-induced ribonucleic acid and protein synthesis for augmentation of luteinizing hormone secretion, *Endocrinology* 129:3234, 1991.
  182. **Waring DW, Turgeon JL**, A pathway for luteinizing hormone releasing-hormone self-potential: cross-talk with the progesterone receptor, *Endocrinology* 130:3275, 1992.
  183. **Wildt L, Hutchison JS, Marshall G, Pohl CR, Knobil E**, On the site of action of progesterone in the blockade of the estradiol-induced gonadotropin discharge in the rhesus monkey, *Endocrinology* 109:1293, 1981.
  184. **Batra SK, Miller WL**, Progesterone decreases the responsiveness of ovine pituitary cultures to luteinizing hormone-releasing hormone, *Endocrinology* 117:1436, 1985.
  185. **Araki S, Chikazawa K, Motoyama M, Ljima K, Abe N, Tamada T**, Reduction in pituitary desensitization and prolongation of gonadotropin release by estrogen during continuous administration of gonadotropin-releasing hormone in women: its antagonism by progesterone, *J Clin Endocrinol Metab* 60:590, 1985.
  186. **Kasa-Vuvu JZ, Dahl GE, Evans NP, Thrun LA, Moenter SM, Padmanaghan V, Karsch FJ**, Progesterone blocks the estradiol-induced gonadotropin discharge in the ewe by inhibiting the surge of gonadotropin-releasing hormone, *Endocrinology* 131:208, 1992.
  187. **Tamarkin L, Baird CJ, Almeida OFX**, Melatonin: a coordinating signal for mammalian reproduction?, *Science* 227:714, 1985.
  188. **Reiter RJ**, Pineal melatonin: cell biology of its synthesis and of its physiological interactions, *Endocr Rev* 12:151, 1991.
  189. **Brzezinski A**, Melatonin in humans, *N Engl J Med* 336:186, 1997.
  190. **Plant TM, Zorub DS**, Pinealectomy in gonadal infantile male rhesus monkeys (*Macaca mulatta*) does not interrupt initiation of the prepubertal hiatus in gonadotropin secretion, *Endocrinology* 118:227, 1986.
  191. **Silman R**, Melatonin and the human gonadotrophin-releasing hormone pulse generator, *J Endocrinol* 128:7, 1991.
  192. **Goldman BD**, Mammalian photoperiodic system: formal properties and neuroendocrine mechanisms of photoperiodic time measurements, *J Biol Rhythms* 16:283, 2001.
  193. **Cajochen C, Krauchi K, Wirz-Justice A**, Role of melatonin in the regulation of human circadian rhythms and sleep, *J Neuroendocrinol* 15:432, 2003.
  194. **Berga S, Mortola J, Yen SSC**, Amplification of nocturnal melatonin secretion in women with functional hypothalamic amenorrhea, *J Clin Endocrinol Metab* 66:242, 1988.
  195. **Zacharias L, Wurtman RJ**, Blindness: its relation to age of menarche, *Science* 144:1154, 1964.
  196. **Zeitler JM, Daniels JE, Duffy JF, Klerman EB, Shanahan TL, Dijk DJ, Czeisler CA**, Do plasma

- melatonin concentrations decline with age?, *Am J Med* 107:432, 1999.
197. **Sack RL, Lewy AJ, Blood ML, Keith LD, Nakagawa H**, Circadian rhythm abnormalities in totally blind people: incidence and clinical significance, *J Clin Endocrinol Metab* 75:127, 1992.
  198. **Kaupilla A, Kivela A, Pakarinen A, Vakkuri O**, Inverse seasonal relationship between melatonin and ovarian activity in humans in a region with a strong seasonal contrast in luminosity, *J Clin Endocrinol Metab* 65:823, 1987.
  199. **Rojansky N, Brzezinski A, Schenker JG**, Seasonality in human reproduction: an update, *Hum Reprod* 7:735, 1992.
  200. **Puig-Domingo M, Webb SM, Serrano J, Peinado M-A, Corcoy R, Ruscalleda J, Reiter RJ, de Leiva A**, Brief report: melatonin-related hypogonadotropic hypogonadism, *N Engl J Med* 327:1356, 1992.
  201. **Okatani Y, Morioka N, Wakatsuki A**, Changes in nocturnal melatonin secretion in perimenopausal women: correlation with endogenous estrogen concentrations, *J Pineal Res* 28:111, 2000.
  202. **Wilson HC, Kiefhaber SH, Gravel V**, Two studies of menstrual synchrony: negative results, *Psychoneuroendocrinology* 16:353, 1991.
  203. **Shinohara K, Morofushi M, Funabashi T, Kimura F**, Axillary pheromones modulate pulsatile LH secretion in humans, *Neuroreport* 12:893, 2001.
  204. **Huhtaniemi IT, Warren DW**, Ontogeny of pituitary-gonadal interactions: current advances and controversies, *Trends Endocrinol Metab* 1:356, 1990.
  205. **Burger HG, Famada Y, Bangah ML, McCloud PI, Warne GL**, Serum gonadotropin, sex steroid, and immunoreactive inhibin levels in the first two years of life, *J Clin Endocrinol Metab* 72:682, 1991.
  206. **Winter JSD, Faiman C**, Serum gonadotropin concentrations in gonadal children and adults, *J Clin Endocrinol Metab* 35:561, 1972.
  207. **Mitushima D, Hei DL, Terasawa E**, gamma-Aminobutyric acid is an inhibitory neurotransmitter restricting the release of luteinizing hormone-releasing hormone before the onset of puberty, *Proc Natl Acad Sci* 91:395, 1994.
  208. **Keen KL, Burich AJ, Mitushima D, Kasuya E, Terasawa E**, Effects of pulsatile infusion of the GABA(A) receptor blocker bicuculine on the onset of puberty in female rhesus monkeys, *Endocrinology* 140:5257, 1999.
  209. **El Majdoubi M, Sahu A, Ramaswamy S, Plant TM**, Neuropeptide Y: a hypothalamic brake restraining the onset of puberty in primates, *Proc Natl Acad Sci U S A* 97:6179, 2000.
  210. **Popa SM, Clifton DK, Steiner RA**, The role of kisspeptins and GPR54 in the neuroendocrine regulation of reproduction, *Annu Rev Physiol* 70:213, 2008.
  211. **Shahab M, Mastronardi C, Siminara SB, Crowley WF, Ojeda SR, Plant TM**, Increased hypothalamic GPR54 signaling: a potential mechanism for initiation of puberty in primates, *Proc Natl Acad Sci* 102:2129, 2005.
  212. **Sklar CA, Kaplan SL, Grumbach MM**, Evidence for dissociation between adrenarche and gonadarche: studies in patients with idiopathic precocious puberty, gonadal dysgenesis, isolated gonadotropin deficiency, and constitutionally delayed growth and adolescence, *J Clin Endocrinol Metab* 51:548, 1980.
  213. **Palmert MR, Hayden DL, Mansfield MJ, Crigler JF Jr, Crowley WF Jr, Chandler DW, Boepple PA**, The longitudinal study of adrenal maturation during gonadal suppression: evidence that adrenarche is a gradual process, *J Clin Endocrinol Metab* 86:4536, 2001.
  214. **Plant TM, Durrant AR**, Circulating leptin does not appear to provide a signal for triggering the initiation of puberty in the male rhesus monkey (*Macaca mulatta*), *Endocrinology* 138:4505, 1997.
  215. **Dunkel L, Alftan H, Stenman U-H, Selstam G, Rosberg S, Albertsson-Wikland K**, Developmental changes in 24-hour profiles of luteinizing hormone and follicle-stimulating hormone from prepuberty to midstages of puberty in boys, *J Clin Endocrinol Metab* 74:890, 1992.
  216. **Oerter KE, Urarte MM, Rose SR, Barnes KM, Cutler GB**, Gonadotropin secretory dynamics during puberty in normal girls and boys, *J Clin Endocrinol Metab* 71:1251, 1990.
  217. **Apter D, Butzow TL, Laughlin GA, Yen SSC**, Gonadotropin-releasing hormone pulse generator activity during pubertal transition in girls: pulsatile and diurnal patterns of circulating gonadotropins, *J Clin Endocrinol Metab* 76:940, 1993.

218. **Cemeroglu AP, Foster CM, Warner R, Kletter GB, Marshall JC, Kelch RP**, Comparison of the neuroendocrine control of pubertal maturation in girls and boys with spontaneous puberty and in hypogonadal girls, *J Clin Endocrinol Metab* 81:4352, 1996.
219. **Clark PA, Iranmanesh A, Veldhuis JD, Rogol AD**, Comparison of pulsatile luteinizing hormone secretion between prepubertal children and young adults: evidence for a mass/amplitude-dependent difference without gender or day/night contrasts, *J Clin Endocrinol Metab* 82:2950, 1997.
220. **Boyar RM, Ramsey J, Chapman J, Fevere M, Madden J, Marks JF**, Luteinizing hormone and follicle-stimulating hormone secretory dynamics in Turner's syndrome, *J Clin Endocrinol Metab* 47:1078, 1978.
221. **Zacharias L, Rand WM, Wurtman RJ**, A prospective study of sexual development and growth in American girls: the statistics of menarche, *Obstet Gynecol Surv* 31:325, 1976.
222. **Anderson SE, Must A**, Interpreting the continued decline in the average age at menarche: results from two nationally representative surveys of U.S. girls studied 10 years apart, *J Pediatr* 147:753, 2005.
223. **Frisch RE**, Body fat, menarche, and reproductive ability, *Semin Reprod Endocrinol* 3:45, 1985.
224. **Ross JL, Loriaux DL, Cutler GB**, Developmental changes in neuroendocrine regulation of gonadotropin secretion in gonadal dysgenesis, *J Clin Endocrinol Metab* 57:288, 1983.

---

# Regulation of the Menstrual Cycle

Many superstitious beliefs have surrounded menstruation throughout recorded history. Indeed, attitudes and ideas about this aspect of female physiology have changed slowly. Hopefully, the scientific progress of the last few decades, which has revealed the dynamic relationships between the hypothalamic, pituitary, and gonadal hormones and the cyclic nature of the normal reproductive process, will yield a better understanding. The hormone changes, correlated with the morphologic and autocrine-paracrine events in the ovary, make the coordination of this system one of the most remarkable events in biology.

The diagnosis and management of abnormal menstrual function must be based on an understanding of the physiologic mechanisms involved in the regulation of the normal cycle. To understand the normal menstrual cycle, it is helpful to divide the cycle into three distinct phases: the follicular phase, ovulation, and the luteal phase. We will examine each of these segments of the menstrual cycle, concentrating on the changes in ovarian and pituitary hormones, processes that govern the pattern of hormone changes, and the effects of these hormones on the ovary, pituitary, and hypothalamus in regulating the menstrual cycle.

# THE FOLLICULAR PHASE

---

In the human ovary, an orderly sequence of events in the follicular phase of the menstrual cycle results in the selection of a single follicle (dominant follicle) from within a group of immature follicles, and which is eventually ready for ovulation. This process, which occurs over the space of 10–14 days, features a series of sequential actions of hormones and autocrine-paracrine peptides on the follicle, leading the follicle destined to ovulate through a period of initial growth from a primordial follicle through the stages of the preantral, antral, and preovulatory follicle.



# The Primordial Follicle

The primordial germ cells originate in the endoderm of the yolk sac, allantois, and hindgut of the embryo, and by 5–6 weeks of gestation, they have migrated to the genital ridge. A rapid mitotic multiplication of germ cells begins at 6–8 weeks of pregnancy, and by 16–20 weeks, the maximum number of oocytes is reached: a total of 6–7 million in both ovaries.<sup>1</sup> The primordial follicle consists of an oocyte that is arrested in the diplotene stage of meiotic prophase, surrounded by a single layer of spindle-shaped granulosa cells.

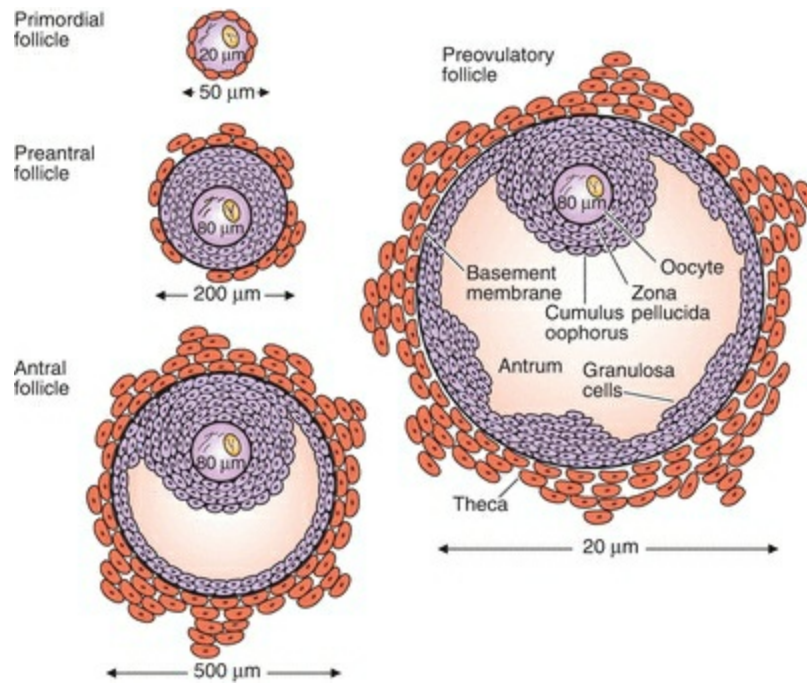
Until their numbers are exhausted, follicles begin to grow and undergo atresia under all physiologic circumstances. Follicular growth and atresia are not interrupted by pregnancy, ovulation, or periods of anovulation. This dynamic process continues at all ages, including infancy and around the menopause. From the maximum number at 16–20 weeks of pregnancy, the number of oocytes will irretrievably decrease. The rate of decrease is proportional to the total number present; thus, the most rapid decrease occurs before birth, resulting in a decline from 6–7 to 2 million at birth and to 300,000 at puberty. From this large reservoir, about 400 follicles will ovulate during a woman's reproductive years.

The mechanism for determining which follicles and how many will start growing during any one cycle is unknown. The number of follicles that starts growing each cycle appears to be dependent upon the size of the residual pool of inactive primordial follicles.<sup>2,3</sup> Reducing the size of the pool (e.g., unilateral oophorectomy) causes the remaining follicles to redistribute their availability over time. It is possible that the follicle that is singled out to play the leading role in a particular cycle is the beneficiary of a timely match of follicle “readiness” (perhaps prepared by autocrine-paracrine actions in its microenvironment), and appropriate tropic hormone stimulation. The first follicle able to respond to stimulation may achieve an early lead that it never relinquishes. Nevertheless, each cohort of follicles that begins growth is engaged in a serious competition that ends, in humans, with only one of the cohort eventually succeeding to attain dominance.

## Rescue from Atresia (Apoptosis)

The early growth of follicles occurs over the time span of several menstrual cycles. The ovulatory follicle is one of a cohort that gets recruited at the time of the luteal-follicular transition in the preceding cycle.<sup>4,5,6</sup> The total duration of time to achieve preovulatory status is approximately 85 days. The majority of this time (until a late stage) involves responses that are independent of hormonal regulation.<sup>7</sup> Eventually, this cohort of follicles reaches a stage where, unless recruited (rescued) by follicle-stimulating

hormone (FSH), the next step is atresia. Thus, follicles are continuously available (2–5 mm in size) for a response to FSH. An increase in FSH is the critical feature in rescuing a cohort of follicles from atresia, the usual fate of most follicles, eventually allowing a dominant follicle to emerge and pursue a path to ovulation. In addition, maintenance of this increase in FSH for a critical duration of time is essential.<sup>8</sup> Without the appearance and persistence of an increase in the circulating FSH level, the cohort is doomed to the process of apoptosis, programmed physiologic cell death to eliminate superfluous cells.<sup>9</sup> “Apoptosis” is derived from Greek and means falling off, like leaves from a tree (Figure 5.1).



**FIGURE 5.1**

“Recruitment” has been traditionally used to describe the continuing growth of antral follicles in response to FSH. A more useful concept is that the cohort of follicles responding to FSH at the beginning of a cycle is rescued from apoptosis. Remember that the very early development of follicles begins continuously and independently from gonadotropin influence. The fate of almost all of these follicles is apoptosis; only those exposed to an increase in FSH stimulation, because of the juxtaposition of their readiness to respond and the increase in FSH during the luteal-follicular transition, have the good fortune to compete for selection as a dominant follicle.

The first visible signs of follicular development are an increase in the size of the oocyte and the granulosa cells becoming cuboidal rather than squamous in shape. These changes are better viewed as a process of maturation rather than growth. At this same

time, small gap junctions develop between the granulosa cells and the oocyte. Gap junctions are channels that when open permit the exchange of nutrients, ions, and regulatory molecules. Thus, the gap junctions serve as the pathway for nutritional, metabolite, and signal interchange between the granulosa cells and the oocyte, setting the stage for a bidirectional communication between the two cell types. In one direction, inhibition of the final maturation of the oocyte (until the luteinizing hormone [LH] surge) is maintained by factors derived from the granulosa cells. In the other direction, the process of follicular growth is influenced by regulatory factors that originate in the oocyte.

The molecular events that regulate primordial follicle formation involve a variety of factors, all locally produced and regulated, including members of the transforming growth factor beta (TGF- $\beta$ ) superfamily of proteins and another family of trophic factors called neurotrophins. Activins, inhibins, antimüllerian hormone (AMH), and bone morphogenetic proteins (BMPs) are members of the TGF- $\beta$  family of proteins. Activins promote and inhibins retard primordial follicle development, and their relative local concentrations in the fetal ovary during the time of follicle assembly may determine the size of the ovarian follicular pool.<sup>10</sup> AMH is an important inhibitor of primordial follicle growth, and BMPs exert the opposite effect.<sup>10</sup> Neurotrophins and their receptors are essential for the differentiation and survival of various neuronal populations in the central and peripheral nervous systems, but their presence in the developing ovary suggests that they also play a role in ovarian development. Four mammalian neurotrophins have been identified, including nerve growth factor (NGF), brain-derived neurotrophic factor (BDNF), neurotrophin-3 (NT-3), and neurotrophin 4/5 (NT-4/5), all of which exert their actions via binding to high-affinity transmembrane tyrosine kinase receptors encoded by members of the *trk* proto-oncogene family (NGF to TrkA, BDNF and NT-4/5 to TrkB, and NT-3 to TrkC).<sup>11</sup> Observations in NGF- and TrkA-null mice indicate that NGF stimulates the proliferation of ovarian mesenchymal cells during the early stages of follicular assembly and promotes differentiation and synthesis of FSH receptors in granulosa cells. Similar experiments with TrkB-null mice suggest that TrkB signaling is required for oocyte survival after follicular assembly and for preantral follicular development.<sup>11</sup> The specific signaling mechanisms that mediate the effects of activins, inhibins, BMPs, and neurotrophins remain to be established.

Other paracrine factors mediate a bidirectional communication between oocytes and their surrounding granulosa cells. Oocytes are linked to their investment of granulosa cells via gap junctions, which allow passage of small molecules such as ions (e.g., calcium), metabolites (e.g., pyruvate, nucleic acids, inositol), amino acids (e.g., L-alanine), cholesterol, and intracellular signaling molecules (e.g., cyclic adenosine monophosphate [cAMP]) between granulosa cells and oocytes. In mice, targeted deletions of gap junction proteins (known as connexins) disrupt follicular and oocyte

development.<sup>12</sup> Oocytes are unable to use glucose as an energy source to support meiotic maturation, cannot transport certain amino acids, and lack both the enzymes necessary for cholesterol synthesis and the receptors for its uptake from carrier-borne sources. Consequently, oocytes are dependent on adjacent granulosa cells to metabolize glucose into a usable energy substrate, such as pyruvate, for transport of essential amino acids, such as L-alanine, and for synthesis and transfer of cholesterol.<sup>13</sup> **To meet their energy needs, oocytes stimulate glycolysis, amino acid transport, and cholesterol synthesis in granulosa cells via paracrine and juxtacrine signals that promote expression of transcripts involved in these metabolic processes, at least in some species.**<sup>13</sup> Candidate signaling molecules include closely related members of the TGF- $\beta$  family, growth differentiation factor 9 (GDF9) and BMP15; both are expressed robustly in oocytes and appear crucial for normal ovarian follicle development in mammalian species.<sup>14</sup>

Mice that are genetically deficient in GDF-9, a peptide synthesized only in the oocyte after the primordial follicle becomes a preantral follicle, are infertile because follicular development cannot proceed beyond the primordial follicle stage.<sup>15,16</sup> Mutations in GDF-9 are rare causes of ovarian failure, but confirmed BMP-15 mutations have not been reported.<sup>17,18</sup>

Mutations in FOXL2, a gene encoding a transcription factor, cause blepharophimosis/ptosis/epicanthus inversus syndrome, a disorder affecting the eyelid and producing premature ovarian failure.<sup>19,20</sup> This transcription factor has been demonstrated to be essential for granulosa cell differentiation; indeed, mutations are associated with an absence of the very first sign of follicular development, the change in shape of granulosa cells from spindle to a cuboidal.<sup>21</sup>

The gap junction is composed of channels formed by an arrangement of proteins known as connexins, and more recently as GJAs. The connexin gap junctions are essential for growth and multiplication of the granulosa cells, and for the nutrition and regulation of oocyte development.<sup>22</sup> Connexin expression in ovarian follicles is up-regulated by FSH and down-regulated by LH.<sup>23</sup> In addition, FSH maintains an open channel in the gap junctions, a pathway that is closed by LH.<sup>24</sup> After ovulation, the gap junctions are important again in the corpus luteum, when their function is regulated by locally produced oxytocin.<sup>25</sup>

With multiplication of the cuboidal granulosa cells, the primordial follicle becomes a primary follicle. In early stages of primary follicle development, the granulosa cell arrangement around the oocyte appears pseudostratified. The granulosa layer is separated from the stromal cells by a basement membrane called the basal lamina. The surrounding stromal cells differentiate into concentric layers designated the theca

interna (closest to the basal lamina) and the theca externa (the outer portion). The theca layers appear when granulosa proliferation produces 3–6 layers of granulosa cells.<sup>6</sup>

The belief that the initiation of follicular growth from primordial stage is independent of gonadotropin stimulation is supported by the persistence of this initial growth in gonadotropin-deficient mutant mice and in anencephalic fetuses.<sup>26,27</sup> In the vast majority of instances, this growth is limited and rapidly followed by atresia. In studies of human ovarian follicles, expression of the gene for the FSH receptor could not be detected until after primordial follicles began to grow.<sup>28</sup> Furthermore, in a woman with an inactivating mutation in the  $\beta$  (beta) subunit FSH gene, antral follicular activity was present, although successful growth and ovulation were impossible.<sup>29</sup> Treatment of FSH-deficient women with exogenous FSH results in follicular growth, ovulation, and pregnancy, demonstrating that oocytes and growth of follicles until the appearance of FSH are normal.<sup>29,30</sup>

The general pattern of limited growth and quick atresia is interrupted at the beginning of the menstrual cycle when a group of follicles (after approximately 70 days of development) responds to hormonal changes and is propelled to grow. In young women, this cohort numbers 3–11 follicles per ovary.<sup>31</sup> The decline in luteal phase steroidogenesis and inhibin-A secretion in the preceding cycle allows for a progressive late luteal rise in FSH, beginning a few days before menses.<sup>32,33</sup> The timing of this important event was based on data derived from the immunoassay of FSH. Using a sensitive measurement of FSH bioactivity, it has been suggested that increasing bioactivity of FSH begins in the mid- to late luteal phase.<sup>34</sup>

## The Preantral Follicle

Once growth is accelerated, the follicle progresses to the preantral stage as the oocyte enlarges and is surrounded by a membrane, the zona pellucida. The granulosa cells undergo a multilayer proliferation as the theca layer continues to organize from the surrounding stroma. This growth is dependent upon gonadotropins and is correlated with increasing ovarian production of estrogen. Molecular studies indicate that the granulosa cells in mature follicles are all derived from as few as three precursor cells.<sup>35</sup>

The granulosa cells of the preantral follicle have the ability to synthesize all three classes of steroids; however, significantly more estrogens than either androgens or progestins are produced. An aromatase enzyme system acts to convert androgens to estrogens and is a factor limiting ovarian estrogen production. Aromatization is induced or activated through the action of FSH. The binding of FSH to its receptor and activation of the adenylate cyclase-mediated signal is followed by expression of

multiple mRNAs, which encode proteins responsible for cell proliferation, differentiation, and function. Thus, FSH both initiates steroidogenesis (estrogen production) in granulosa cells and stimulates granulosa cell growth.<sup>36</sup>

Specific receptors for FSH are not detected on granulosa cells until the preantral stage,<sup>28</sup> and the preantral follicle requires the presence of FSH in order to aromatize androgens and generate its own estrogenic microenvironment.<sup>37</sup> Cellular estrogen production is, therefore, limited by its FSH receptor content. Administration of FSH will alter the concentration of its own receptor on granulosa cells (both up- and down-regulation), in vivo and in vitro.<sup>38</sup> This action of FSH is modulated by growth factors.<sup>39</sup> FSH receptors quickly reach a concentration of approximately 1,500 receptors per granulosa cell.<sup>40</sup>

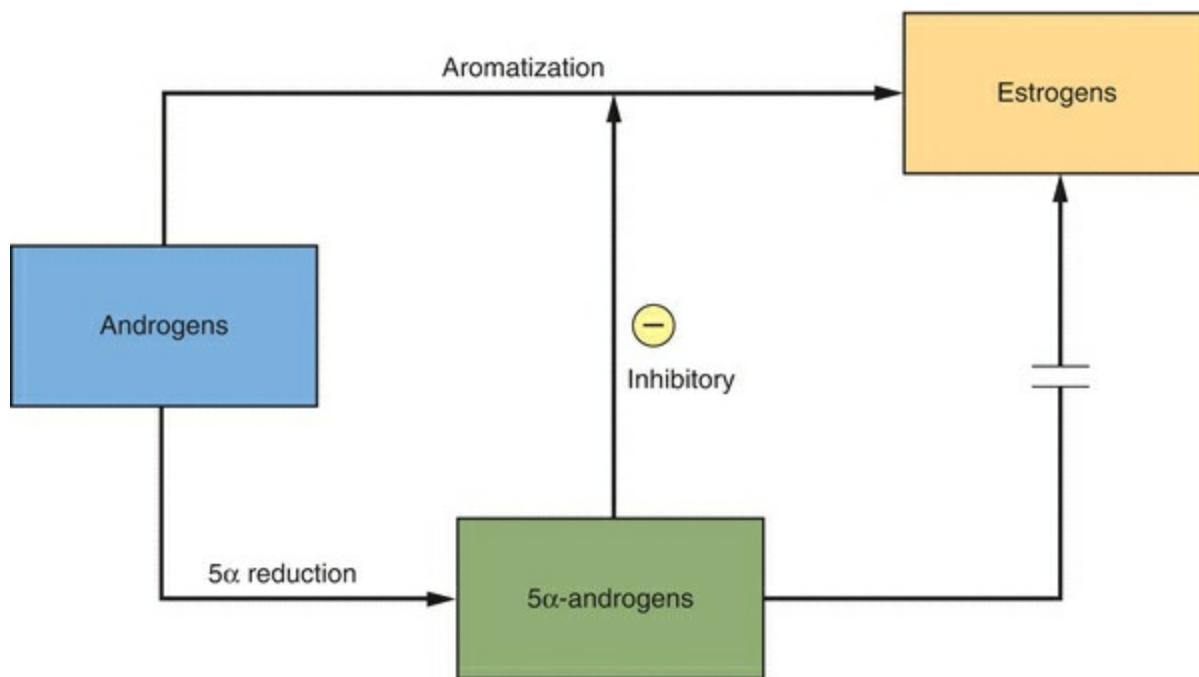
FSH operates through the G protein, adenylate cyclase system (described in [Chapter 1](#)), which is subject to down-regulation and modulation by many factors, including a calcium-calmodulin intermediary. Although steroidogenesis in the ovarian follicle is mainly regulated by the gonadotropins, multiple signaling pathways are involved that respond to many factors besides the gonadotropins. Besides the adenylate cyclase enzyme system, these pathways include ion gate channels, tyrosine kinase receptors, and the phospholipase system of second messengers. These pathways are regulated by a multitude of factors, including growth factors, nitric oxide, prostaglandins, and peptides such as gonadotropin-releasing hormone (GnRH), angiotensin II, tissue necrosis factor- $\alpha$  (alpha), and vasoactive intestinal peptide (VIP). The binding of LH to its receptor in the ovary is also followed by activation of the adenylate cyclase–cyclic AMP pathway via the G protein mechanism.

FSH combines synergistically with estrogen to exert (at least in the nonprimate) a mitogenic action on granulosa cells to stimulate their proliferation. Together, FSH and estrogen promote a rapid accumulation of FSH receptors, reflecting in part the increase in the number of granulosa cells in the dominant follicle. The early appearance of estrogen within the selected follicle allows the follicle to respond to relatively low concentrations of FSH, an autocrine function for estrogen within the follicle. As growth proceeds, the granulosa cells differentiate into several subgroups of different cell populations. This appears to be determined by the position of the cells relative to the oocyte.

There is a system of communication that exists within follicles. Not every cell has to contain receptors for the gonadotropins. Cells with receptors can transfer a signal (by gap junctions), which causes protein kinase activation in cells that lack the receptors.<sup>41</sup> Thus, hormone-initiated action can be transmitted throughout the follicle even though only a subpopulation of cells binds the hormone. This system of communication promotes a coordinated and synchronous performance throughout the follicle, a system

that continues to operate in the corpus luteum.

The role of androgens in early follicular development is complex. Specific androgen receptors are present in the granulosa cells.<sup>42</sup> The androgens serve not only as a substrate for FSH-induced aromatization but, in low concentrations, can further enhance aromatase activity. When exposed to an androgen-rich environment, preantral granulosa cells favor the conversion of androgens to more potent  $5\alpha$ -reduced androgens rather than to estrogens (Figure 5.2).<sup>43</sup> These androgens cannot be converted to estrogen and, in fact, inhibit aromatase activity.<sup>44</sup> They also inhibit FSH induction of LH receptor formation, another essential step in follicular development.<sup>45</sup>



**FIGURE 5.2**

**The fate of the preantral follicle is in delicate balance.** At low concentrations, androgens enhance their own aromatization and contribute to estrogen production. At higher levels, the limited capacity of aromatization is overwhelmed, and the follicle becomes androgenic and ultimately atretic.<sup>46</sup> The FSH to LH ratio is important for follicular recruitment and development. Follicles will progress in development only if emerging when FSH is elevated and LH is low. Those follicles arising at the end of the luteal phase or early in the subsequent cycle would be favored by an environment in which aromatization in the granulosa cell can prevail. **The success of a follicle depends upon its ability to convert an androgen-dominated microenvironment to an estrogen-dominated microenvironment.**<sup>47,48</sup>

## Key Points: Preantral Follicle

- Initial follicular development occurs independently of hormone influence.
- FSH stimulation propels follicles to the preantral stage.
- FSH-induced aromatization of androgen in the granulosa results in the production of estrogen.
- Together, FSH and estrogen increase the FSH receptor content of the follicle.



# The Antral Follicle

Under the synergistic influence of estrogen and FSH, there is an increase in the production of follicular fluid that accumulates in the intercellular spaces of the granulosa, eventually coalescing to form a cavity, as the follicle makes its gradual transition to the antral stage. The accumulation of follicular fluid provides a means whereby the oocyte and surrounding granulosa cells can be nurtured in a specific endocrine environment. The granulosa cells surrounding the oocyte are now designated the **cumulus oophorus**. The differentiation of the cumulus cells is believed to be a response to signals originating in the oocyte.<sup>49</sup> The follicular fluid, rich in hormones, growth factors, and cytokines, provides the milieu that is required for the orderly maturation and development of the oocyte and its surrounding cells.

In the presence of FSH, estrogen becomes the dominant substance in the follicular fluid. Conversely, in the absence of FSH, androgens predominate.<sup>50,51</sup> LH is not normally present in follicular fluid until the midcycle. If LH is prematurely elevated in the plasma and antral fluid, mitotic activity in the granulosa decreases, degenerative changes ensue, and intrafollicular androgen levels rise. Therefore, the dominance of estrogen and FSH is essential for sustained accumulation of granulosa cells and continued follicular growth. Antral follicles with the greatest rates of granulosa proliferation contain the highest estrogen concentrations and the lowest androgen/estrogen ratios, and are the most likely to house a healthy oocyte.<sup>52</sup> An androgenic milieu antagonizes estrogen-induced granulosa proliferation and, if sustained, promotes degenerative changes in the oocyte.

The steroids present in follicular fluid can be found in concentrations several orders of magnitude higher than those in plasma and reflect the functional capacity of the surrounding granulosa and theca cells. The synthesis of steroid hormones is functionally compartmentalized within the follicle: the two-cell system.<sup>40,46,51,53,54</sup>

## The Two-Cell, Two-Gonadotropin System

The aromatase activity of the granulosa far exceeds that observed in the theca. In human preantral and antral follicles, LH receptors are present only on the theca cells and FSH receptors only on the granulosa cells.<sup>55,56</sup> Theca interstitial cells, located in the theca interna, have approximately 20,000 LH receptors in their cell membranes. In response to LH, theca tissue is stimulated to produce androgens that can then be converted, through FSH-induced aromatization, to estrogens in the granulosa cells.

The interaction between the granulosa and theca compartments, with resulting accelerated estrogen production, is not fully functional until later in antral development. Like preantral granulosa cells, the granulosa of small antral follicles exhibits an in vitro

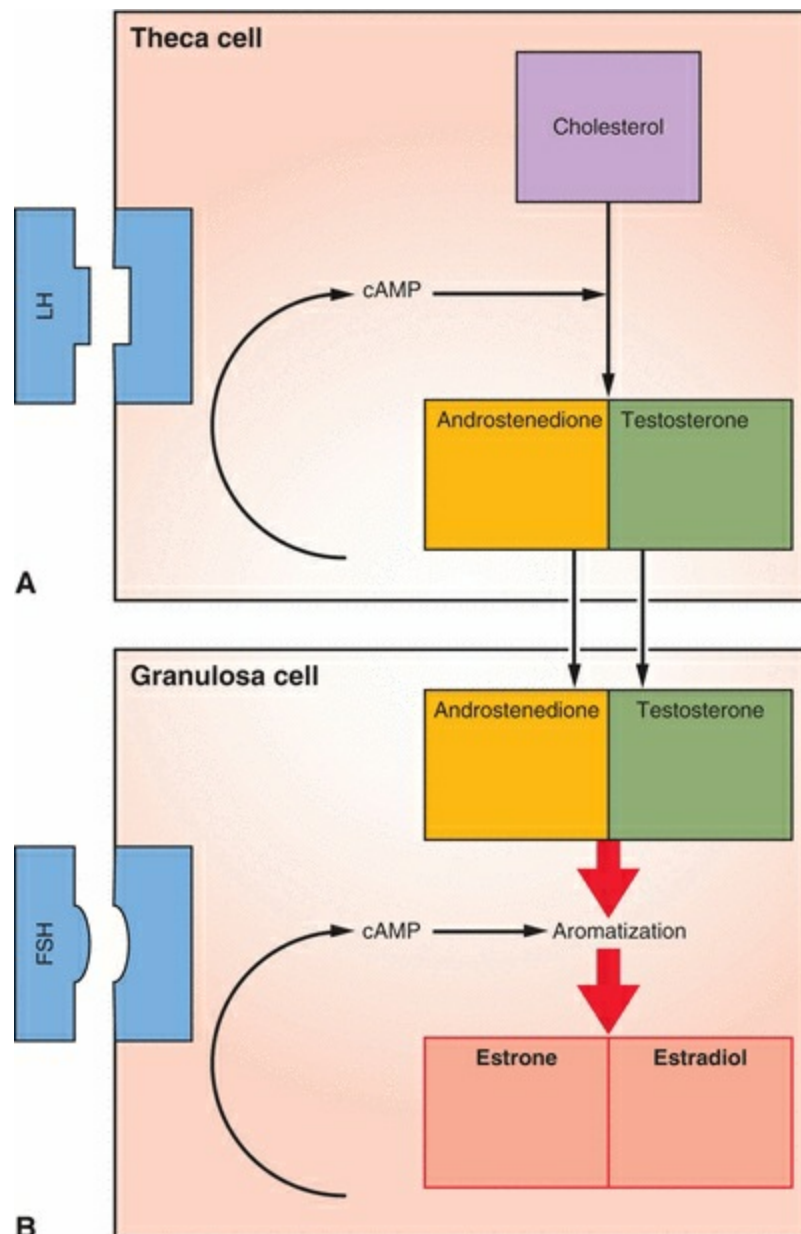
tendency to convert significant amounts of androgen to the more potent  $5\alpha$ -reduced form. In contrast, granulosa cells isolated from large antral follicles readily and preferentially metabolize androgens to estrogens. The conversion from an androgen microenvironment to an estrogen microenvironment (a change that is essential for further growth and development) is dependent upon a growing sensitivity to FSH brought about by the action of FSH and the enhancing influence of estrogen.

As the follicle develops, theca cells begin to express the genes for LH receptors, P450<sub>scc</sub>, and  $3\beta$ -hydroxysteroid dehydrogenase.<sup>57</sup> The separately regulated (by LH) entry of cholesterol into the mitochondria, utilizing internalization of low-density lipoprotein (LDL) cholesterol, is essential for steroidogenesis. **Therefore, ovarian steroidogenesis is LH dependent to a significant degree.** Human ovarian granulosa cells, after luteinization and vascularization that occur following ovulation, can use high-density lipoprotein (HDL) cholesterol in a system that differs from the LDL-cholesterol pathway. The HDL lipoproteins are not internalized, but rather, the cholesteryl esters are extracted from the lipoproteins at the cell surface and then transferred into the cell.<sup>58</sup>

As the follicle matures, the theca cells are characterized by their expression of P450<sub>c17</sub>, the enzyme step, which is rate limiting for the conversion of 21-carbon substrate to androgens.<sup>59</sup> Granulosa cells do not express P450<sub>c17</sub> and thus are dependent upon androgens from the theca in order to make estrogen. Increasing expression of the aromatization system (P450<sub>arom</sub>) is a marker of increasing maturity of granulosa cells. The presence of P450<sub>c17</sub> only in theca cells and P450<sub>arom</sub> only in granulosa cells is impressive evidence confirming the two-cell, two-gonadotropin explanation for estrogen production.<sup>60</sup>

The importance of the two-cell, two-gonadotropin system in the primate (**Figure 5.3**) is supported by the response of women with a deficiency in gonadotropins to treatment with recombinant (pure) FSH.<sup>61,62,63</sup> Follicles developed in these women (confirming the essential role of FSH, and the lesser role for LH, in recruitment and initial growth), but estradiol production was limited. Some aromatization occurred, perhaps using androgens originating in the adrenal glands, producing early follicular phase estradiol levels, but the usual robust steroidogenesis was impossible without the presence of LH to provide theca production of androgen substrate. This same response has been observed in experiments that use a GnRH antagonist to produce LH-deficient monkeys, followed by the administration of recombinant, pure human FSH.<sup>64,65</sup> **These results indicate that only FSH is required for folliculogenesis, and that in the primate, autocrine-paracrine peptides have assumed the important intraovarian role of modulating gonadotropin response. However, the final stages of maturation are optimized by LH, increasing the amount of androgen substrate for estrogen**

production and promoting the growth of the dominant follicle while simultaneously hastening the regression of smaller follicles.<sup>66</sup>



**FIGURE 5.3**

## Selection of the Dominant Follicle

The successful conversion to an estrogen-dominant follicle marks the “selection” of a follicle destined to ovulate, the process whereby, with rare exception in humans, only a single follicle succeeds in each cycle.<sup>67</sup> This selection process is to a significant degree the result of two estrogen actions: (1) a local interaction between estrogen and FSH

within the follicle and (2) the effect of estrogen on pituitary secretion of FSH. While estrogen exerts a positive influence on FSH action within the maturing follicle, its negative feedback relationship with FSH at the hypothalamic-pituitary level serves to withdraw gonadotropin support from the other less-developed follicles. The fall in FSH leads to a decline in FSH-dependent aromatase activity, limiting estrogen production in the less mature follicles. Even if a lesser follicle succeeds in achieving an estrogen microenvironment, decreasing FSH support would interrupt granulosa proliferation and function, promote a conversion to an androgenic microenvironment, and thereby induce irreversible atretic change. Indeed, the first event in the process of atresia is a reduction in FSH receptors in the granulosa layer.

The loss of oocytes (and follicles) through atresia is a response to changes in many factors. Certainly gonadotropin stimulation and withdrawal are important, but ovarian steroids and autocrine-paracrine factors are also involved. The consequence of these unfavorable changes, atresia, in the process called **apoptosis**, programmed cell death, is heralded by alterations in mRNAs required for cell proteins that maintain follicle integrity.<sup>68</sup> This type of “natural death” is a physiologic process, in contrast to the pathologic cell death of necrosis.

Once cells have entered the process of apoptosis, their response to FSH is modulated by local growth factors. Tumor necrosis factor (TNF), produced in the granulosa cells, inhibits FSH stimulation of estradiol secretion, except in the dominant follicle.<sup>69</sup> An inverse relationship exists between TNF expression and gonadotropin stimulation of granulosa cells. Thus, as the successful follicle increases its response to gonadotropins, its TNF production decreases. Those follicles with a failing response to gonadotropins increase their TNF production, hastening their own demise.

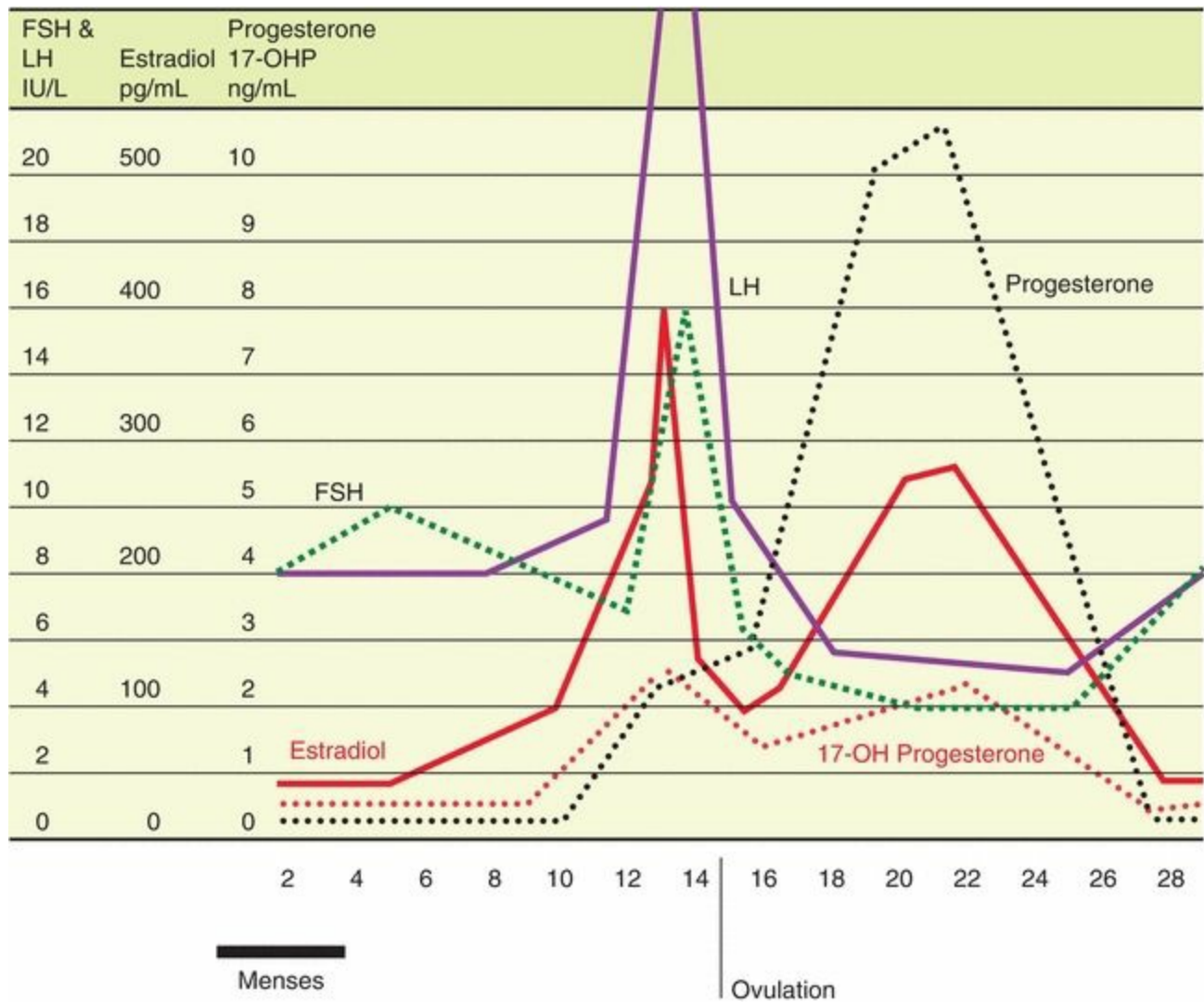
Although the principal function of AMH is to cause müllerian duct regression during male embryonic sexual differentiation, AMH is detected in the granulosa cells of early primordial follicles and reaches peak concentrations in the small antral follicles.<sup>70</sup> Its secretion appears to be regulated by the mature oocyte, and AMH decreases when FSH-stimulated follicular growth and estrogen production occur.<sup>71,72</sup> Studies with knockout model mice have indicated that AMH inhibits the recruitment of primordial follicles.<sup>73</sup> The paracrine activity of AMH inhibits FSH-stimulated follicle growth, thus suppressing the growth of lesser follicles and allowing the dominant follicle to emerge. Because of these activities, the circulating level of AMH reflects the number of growing follicles, and the blood concentration of AMH is a recognized measure of ovarian aging and as a prognostic marker for ovarian response during fertility treatment.<sup>74</sup> AMH levels are relatively unaffected by gonadotropins or the sex steroids. Measurement of AMH is reliable on any day in an individual’s menstrual cycle,<sup>75</sup> although prolonged periods of ovarian suppression, such as with use of hormonal contraceptives, can result

in spuriously lower circulating AMH levels.<sup>76</sup>

An asymmetry in ovarian estrogen production, an expression of the emerging dominant follicle, can be detected in ovarian venous effluent as early as 5th day of the cycle, corresponding with the gradual fall of FSH levels observed at the mid-follicular phase and preceding the increase in diameter that marks the physical emergence of the dominant follicle.<sup>77</sup> This is a crucial time in the cycle. Exogenous estrogen, administered even after selection of the dominant follicle, disrupts preovulatory development and induces atresia by reducing FSH levels below the sustaining level. Because the lesser follicles have entered the process of atresia, loss of the dominant follicle during this period requires beginning over, with recruitment of another set of preantral follicles.<sup>78</sup>

The negative feedback of estrogen on FSH serves to inhibit the development of all but the dominant follicle. The selected follicle remains dependent upon FSH and must complete its preovulatory development in the face of declining plasma levels of FSH. The dominant follicle, therefore, must escape the consequences of declining FSH induced by its own accelerating estrogen production. **The dominant follicle has two significant advantages, a greater content of FSH receptors acquired because of a rate of granulosa proliferation that surpasses that of its cohorts and enhancement of FSH action because of its high intrafollicular estrogen concentration, a consequence of local autocrine-paracrine molecules.** Thus, the dominant follicle is more sensitive to FSH, and as long as a critical duration of FSH exposure was initially present, the dominant follicle continues to develop.<sup>8</sup> As a result, the stimulus for aromatization, FSH, can be maintained, while at the same time, it is being withdrawn from among the less-developed follicles. A wave of atresia among the lesser follicles, therefore, is seen to parallel the rise in estrogen.

The accumulation of a greater mass of granulosa cells is accompanied by advanced development of the theca vasculature. By day 9, theca vascularity in the dominant follicle is twice that of other antral follicles.<sup>79</sup> This allows a preferential delivery of gonadotropins to the follicle, permitting the dominant follicle to retain FSH responsiveness and sustain continued development and function despite waning gonadotropin levels. The monkey ovary expresses a potent growth factor (vascular endothelial growth factor [VEGF]) that induces angiogenesis, and this expression is observed at the two development points when proliferation of capillaries is important: the emerging dominant follicle and the early corpus luteum (**Figure 5.4**).<sup>80,81</sup>



**FIGURE 5.4**

In order to respond to the ovulatory LH surge and to become a successful corpus luteum, the granulosa cells must acquire LH receptors. FSH induces LH receptor development on the granulosa cells of the large antral follicles. Here again estrogen and local autocrine-paracrine peptides (primate), serve as the chief coordinators. With increasing concentrations of estrogen within the follicle, FSH changes its focus of action, from up-regulating its own receptor to the generation of LH receptors.<sup>82</sup> The combination of a capacity for continued response despite declining levels of FSH and a high local estrogen environment in the dominant follicle provides optimal conditions for LH receptor development. LH can induce the formation of its own receptor in FSH-primed granulosa cells, but the primary mechanism utilizes FSH stimulation and estrogen enhancement.<sup>83,84</sup> The role for estrogen goes beyond synergism and enhancement; it is obligatory.

Evidence from ovarian stimulation for in vitro fertilization indicates that LH plays a

critical role in the late stages of follicle development, providing support for the final maturation and function of the dominant follicle.<sup>66,85</sup> At least one LH contribution in the late follicular phase is the LH-mediated stimulation of androgen production in the theca to provide for the large amounts of estrogen required at this point in the cycle. In addition, the theca androgens may have a direct beneficial effect on essential growth factors within the follicle. LH presence in the follicle prior to ovulation, therefore, is an important contributor to optimal follicular development that ultimately provides a healthy oocyte.<sup>86,87</sup>

The local action of estrogen within the ovarian follicle was questioned when initial studies failed to detect estrogen receptors in any of the significant ovarian compartments.<sup>88</sup> Subsequently, it was discovered that human granulosa cells and primate oocytes contain only mRNA for estrogen receptor- $\beta$ .<sup>89,90,91,92</sup> The dynamic expression of estrogen receptor- $\beta$  is consistent with an important local role for estrogen in ovarian follicle and corpus luteum growth and function.

Although prolactin is always present in follicular fluid, there is no evidence to suggest that prolactin is important during normal ovulatory cycles in the primate.

## The Feedback System

Through its own estrogen and peptide production, the dominant follicle assumes control of its own destiny. By altering gonadotropin secretion through feedback mechanisms, it optimizes its own environment to the detriment of the lesser follicles.

As reviewed in [Chapter 4](#), GnRH plays an obligatory role in the control of gonadotropin secretion, but the pattern of gonadotropin secretion observed in the menstrual cycle is the result of feedback modulation of steroids and peptides originating in the dominant follicle, acting directly on the hypothalamus and anterior pituitary.<sup>4</sup> An increase in GnRH accompanying the LH surge, indicating that positive feedback of estrogen operates at both pituitary and hypothalamic sites, has been reported in monkeys, but not in women.<sup>93,94</sup> Interestingly, positron emission tomography (PET) studies in women have indicated that the positive feedback effects of estrogen on LH occur at the level of the pituitary.<sup>95</sup>

Estrogen exerts its inhibitory effects in both the hypothalamus and the anterior pituitary, decreasing both GnRH pulsatile secretion and the pituitary gonadotropin response to GnRH.<sup>96</sup> Progesterone also operates at these two sites. Its inhibitory action is at the hypothalamic level, and its positive action is directly on the pituitary.<sup>97</sup> As determined by PET studies, the primary site of estrogen-negative feedback on LH is the hypothalamus.<sup>95</sup>

The secretion of FSH is very sensitive to the negative inhibitory effects of estrogen even at low levels. At higher levels, estrogen combines with inhibin for a suppression of FSH that is profound and sustained. In contrast, the influence of estrogen on LH release varies with concentration and duration of exposure. At low levels, estrogen imposes a negative feedback relationship with LH. At higher levels, however, estrogen is capable of exerting a positive stimulatory feedback effect on LH release.

The transition from estrogen-mediated suppression to stimulation of LH release occurs as estradiol levels rise during the midfollicular phase. There are two critical features in this mechanism: (1) the concentration of estradiol and (2) the length of time during which the estradiol elevation is sustained. In women, the estradiol concentration necessary to achieve a positive feedback effect on LH release is more than 200 pg/mL, and this concentration must be sustained for approximately 50 hours.<sup>98</sup> In spontaneous cycles, this level of circulating estrogen is achieved approximately when the dominant follicle has reached a diameter of 15 mm.<sup>99</sup> The estrogen stimulus must be sustained beyond the initiation of the LH surge until after the surge actually begins. Otherwise, the LH surge is abbreviated or fails to occur at all.

Within the well-established monthly pattern, the gonadotropins are secreted in a pulsatile fashion with a frequency and magnitude that vary with the phase of the cycle. While the pulsatile pattern of gonadotropins is directly due to a similar pulsatile secretion of GnRH, the amplitude and frequency modulations are the consequence of steroid feedback on both the hypothalamus and the anterior pituitary.<sup>100,101,102</sup> **Pulsatile secretion is more frequent but smaller in amplitude during the follicular phase compared to the luteal phase, with a slight increase in frequency observed as the follicular phase progresses to ovulation.**

The pulsatile pattern of FSH is not easily discerned because of its relatively longer half-life compared to LH, but the experimental data indicate that FSH and LH are secreted simultaneously and that GnRH stimulates the secretion of both gonadotropins. Even as late as only 36–48 hours before menses, gonadotropin secretion is still characterized by infrequent LH pulses and low FSH levels typical of the late luteal phase.<sup>100</sup> During the transition from the previous luteal phase to the next follicular phase, GnRH and the gonadotropins are released from the inhibitory effects of estradiol, progesterone, and inhibin. A progressive and fairly rapid increase in GnRH pulse secretion is associated with a preferential secretion of FSH compared to LH. The frequency of GnRH and LH pulses increases 4.5-fold during this period and is accompanied by a 3.5-fold increase in the circulating levels of FSH and a lesser 2-fold increase in LH levels.<sup>103</sup>

The GnRH pulse frequency changes in the luteal phase correlate with duration of exposure to progesterone, while pulse amplitude changes appear to be influenced by



changes in progesterone levels.<sup>100</sup> Both estradiol and progesterone are required to achieve the low, suppressed secretory pattern of GnRH during the luteal phase.<sup>104</sup> Evidence supports that the circulating steroids influence changes in both frequency and amplitude of gonadotropin pulses in the different phases of the cycle; the frequency of gonadotropin pulses is modulated through effects on frequency of GnRH release at the level of the hypothalamus, whereas the amplitude of gonadotropin pulses is mediated by actions of steroids at the level of the pituitary. The inhibitory action of luteal phase steroids on gonadotropin release appears to be mediated by an increase in hypothalamic endogenous opioid peptides. Both estrogen and progesterone can increase endogenous opiates. Estrogen appears to enhance the stimulatory action of progesterone in the luteal phase on endogenous opioid peptides, creating relatively high levels of endogenous opiates during the luteal phase. Administration of clomiphene (an estrogen receptor antagonist) during the luteal phase increases the LH pulse frequency with no effect on amplitude.<sup>105</sup>

Plasma endorphin begins to rise in the 2 days before the LH peak, coinciding with the midcycle gonadotropin surge.<sup>106</sup> The maximal level is reached just after the LH peak, coinciding with ovulation. Levels then gradually decline until the nadir is reached during menses and the early follicular phase. Monkeys have their highest beta-endorphin levels in the hypophyseal portal blood at midcycle.<sup>106,107</sup> **Normal cyclicality requires sequential periods of high (midcycle and luteal phase) and low (during menses) hypothalamic opioid activity.**

There is another important action of estrogen. A disparity exists between the patterns of FSH and LH secretion as determined by immunoassay and bioassay, indicating that more biologically active gonadotropins are secreted at midcycle than at other times in the cycle.<sup>108</sup> This quality, bioactivity versus immunoreactivity, is determined by the molecular structure of the gonadotropin molecule, a concept referred to in [Chapter 1](#) as heterogeneity of the tropic hormones. There is a well-established relationship between the activity and half-life of glycoprotein hormones and their sialic acid content. The feedback effects of estrogen include modulation of sialylation and the size and activity of the gonadotropins subsequently released, as well as an augmentation of GnRH-stimulated secretory release of biologically active gonadotropin. It certainly makes sense to intensify the gonadotropin effect at midcycle. The positive feedback actions of estrogen, therefore, increase both the quantity and the quality (the bioactivity) of FSH and LH. In addition to the change at midcycle that favors gonadotropin activity at the ovarian follicle, FSH isoforms with greater biologic activity also increase during the late luteal phase, a change that is appropriately geared toward propelling new ovarian follicle growth for the next cycle.<sup>109,110</sup>

There is a diurnal rhythm in FSH and LH secretion.<sup>111</sup> In contrast to the nocturnal

rise seen with other anterior pituitary hormones such as ACTH, thyroid-stimulating hormone (TSH), growth hormone, and prolactin, FSH and LH exhibit nocturnal decline, probably mediated by the endogenous opiates. This diurnal rhythm for LH is present only in the early follicular phase, while FSH maintains a circadian rhythm throughout the menstrual cycle (and thus it is not influenced by steroid hormone feedback) and even in the postmenopausal period of life.

## **Inhibin, Activin, Follistatin**

This family of peptides is synthesized by the granulosa cells in response to FSH and secreted into the follicular fluid and ovarian venous effluent.<sup>112,113,114,115</sup> Expression of these peptides is not limited to the ovary; they are present in many tissues throughout the body, serving as autocrine-paracrine regulators. Inhibin is an important inhibitor of FSH secretion. Activin stimulates FSH release in the pituitary and augments FSH action in the ovary. Follistatin suppresses FSH activity, by binding activin.

Inhibin consists of two dissimilar peptides (known as alpha- and beta-subunits) linked by disulfide bonds. Two forms of inhibin (inhibin A and inhibin B) have been purified, each containing an identical alpha-subunit and distinct but related beta-subunits. Thus, there are three subunits for inhibins: alpha, beta-A, and alpha, beta-B. Each subunit is a product of a different messenger RNA, each derived from its own precursor molecule.

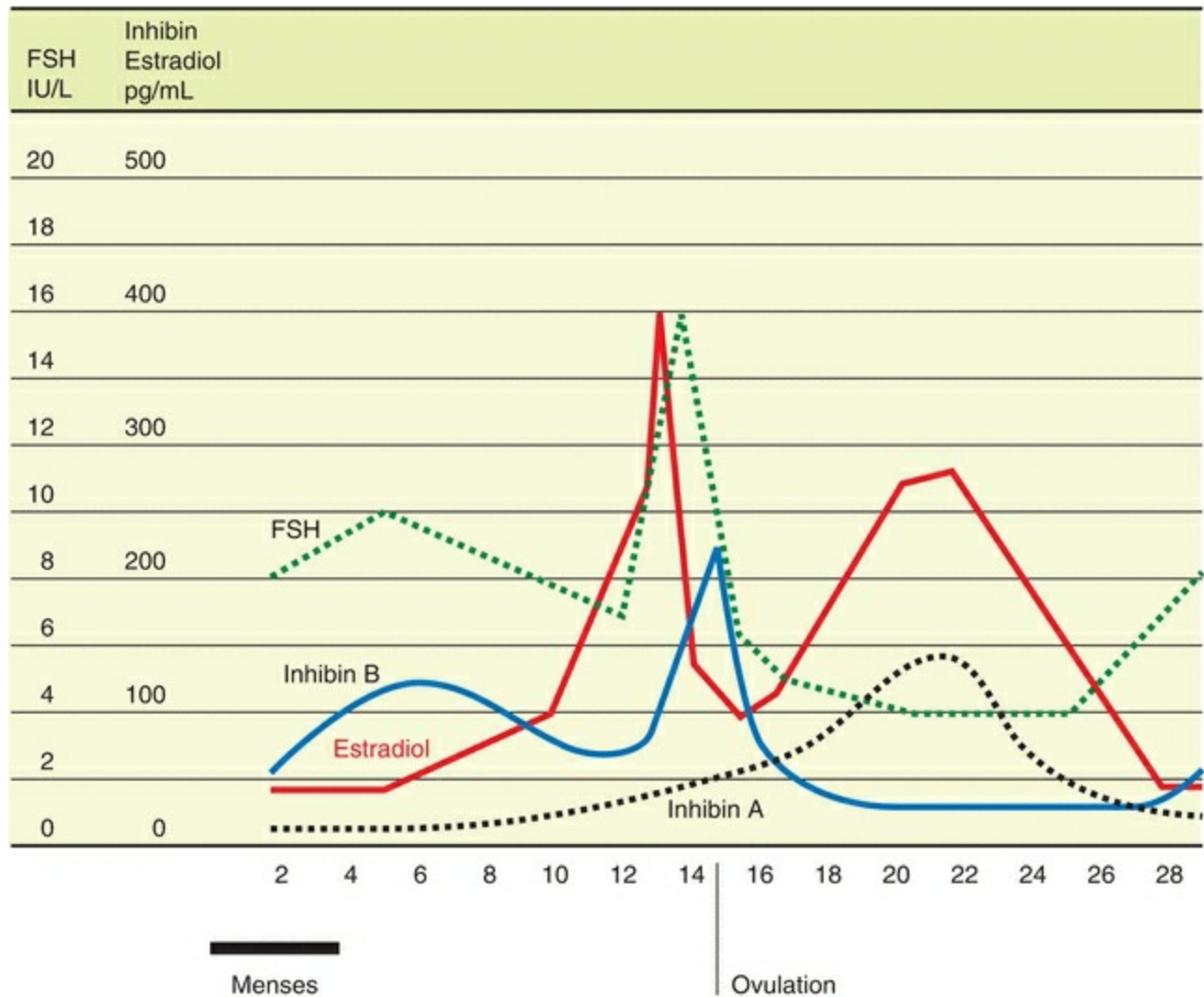
### **The Two Forms of Inhibin:**

- 1. Inhibin A: Alpha-BetaA**
- 2. Inhibin B: Alpha-BetaB**

FSH stimulates the secretion of inhibin from granulosa cells and, in turn, is suppressed by inhibin—a reciprocal relationship.<sup>116,117</sup> Refinements in assay techniques have revealed that inhibin B is the form of inhibin predominantly secreted by granulosa cells in the follicular phase of the cycle.<sup>118,119</sup> The secretion of inhibin is further regulated by local autocrine-paracrine control. GnRH and the epidermal growth factor (EGF) diminish FSH stimulation of inhibin secretion, whereas insulin-like growth factor-I (IGF-I) enhances inhibin production. The inhibitory effects of GnRH and EGF are consistent with their known ability to decrease FSH-stimulated estrogen production and LH receptor formation. The two forms of GnRH (GnRH-I and GnRH-II) along with their receptor are expressed in granulosa cells.<sup>120,121</sup>

**The secretion of inhibin B into the circulation further amplifies the withdrawal of FSH from other follicles, another mechanism by which an emerging follicle secures dominance.** Inhibin B rises slowly but steadily, in a pulsatile fashion (60–70

minute periodicity) reaching peak levels in the early and midfollicular phases, and then decreasing in the late follicular phase before ovulation to reach a nadir in the midluteal phase (**Figure 5.5**).<sup>33,118,122,123</sup> An inhibin-B peak the day after ovulation is probably the result of release from the ruptured follicle. This relationship of inhibin B and FSH is supported by the demonstration that inhibin-B levels are lower and FSH levels are higher in the follicular phase in women 45–49 years old compared to younger women.<sup>122,124</sup> An ovarian fibrothecoma secreting inhibin B predictably was associated with secondary amenorrhea and infertility due to suppression of FSH secretion.<sup>125</sup>



**FIGURE 5.5**

With the appearance of LH receptors on the granulosa cells of the dominant follicle and the subsequent development of the follicle into a corpus luteum, inhibin expression comes under the control of LH, and expression changes from inhibin B to inhibin A.<sup>126</sup>

The circulating levels of inhibin A rise in the late follicular phase to reach a peak level at the midluteal phase.<sup>33,127</sup> Inhibin A, therefore, contributes to the suppression of FSH to nadir levels during the luteal phase and to the changes at the luteal-follicular transition.

Inhibin has multiple, diverse inhibitory effects on gonadotropin secretion. Inhibin can block the synthesis and secretion of FSH, prevent the up-regulation of GnRH receptors by GnRH, reduce the number of GnRH receptors present, and, at high concentrations, promote the intracellular degradation of gonadotropins.

Activin, derived from granulosa cells but also present in the pituitary gonadotropes, contains two subunits that are identical to the beta subunits of inhibin A and B. In addition, activins have been identified with variants of the beta subunits, designated as beta-C, beta-D, and beta-E.<sup>128</sup> The activin beta-C and beta-E genes have been demonstrated to be nonessential in mouse knockout models.<sup>129</sup> Activin augments the secretion of FSH and inhibits prolactin, ACTH, and growth hormone responses.<sup>130,131,132,133</sup> Activin increases pituitary response to GnRH by enhancing GnRH receptor formation.<sup>134,135</sup> The effects of activin are blocked by inhibin and follistatin.<sup>136</sup> The structure of the activin genes is homologous to that of TGF- $\beta$ , indicating that these products all come from the same gene family.<sup>137</sup> Another important member of the TGF- $\beta$  family is the AMH, as well as a protein active during insect embryogenesis and a protein active in frog embryos.

### **The Three Forms of Activin:**

- 1. Activin A: BetaA-BetaA**
- 2. Activin AB: BetaA-BetaB**
- 3. Activin B: BetaB-BetaB**

Activin is present in many cell types, regulating growth and differentiation. In the ovarian follicle, activin increases FSH binding in granulosa cells (by regulating receptor numbers) and augments FSH stimulation of aromatization and inhibin production.<sup>114</sup> Considerable evidence derived from human cells exists to indicate that inhibin and activin act directly on theca cells to regulate androgen synthesis.<sup>138,139,140</sup> Inhibin enhances the stimulatory action of LH and/or IGF-I, while activin suppresses this action. Inhibin in increasing doses can overcome the inhibitory action of activin. Prior to ovulation, activin suppresses progesterone production by granulosa cells, perhaps preventing premature luteinization. There is a repertoire of cell transmembrane kinase receptors for activin, with differing binding affinities and domain structures.<sup>141</sup> This receptor heterogeneity allows the many different responses elicited by a single peptide. Both activin A and inhibin A have been demonstrated to be very potent in

stimulating in vitro maturation of oocytes that subsequently yield a high rate of fertilization.<sup>142</sup>

In the male, activin inhibits and inhibin facilitates LH stimulation of androgen biosynthesis in the testicular Leydig cells. In addition, activin stimulates and inhibin decreases spermatogonial proliferation; inhibin is produced in the Sertoli cell, the locus that has the principal role in modulating spermatogenesis. Thus, activin and inhibin play similar autocrine-paracrine roles in both the male and female gonads.

The anterior pituitary expresses the inhibin-activin subunits, and locally produced activin B augments FSH secretion. Activin A has been demonstrated to directly stimulate the synthesis of GnRH receptors in pituitary cells.<sup>143</sup> Follistatin is a glycopeptide secreted by a variety of pituitary cells, including the gonadotropes.<sup>144</sup> This peptide has also been called FSH-suppressing protein because of its main action: inhibition of FSH synthesis and secretion and the FSH response to GnRH by binding to activin and in that fashion decreasing the activity of activin.<sup>145,146</sup> Activin stimulates follistatin production, and inhibin prevents this response. Follistatin is also expressed by granulosa cells in response to FSH, and, therefore, follistatin, like inhibin and activin, functions locally in the follicle and in the pituitary.<sup>147</sup> Circulating levels of activin increase in the late luteal phase to peak at menses; however, activin A is highly bound in the circulation, and it is not certain it has an endocrine role.<sup>148</sup> Nevertheless, the timing is right for activin to contribute to the rise in FSH during the luteal-follicular transition.

**In summary, the pituitary secretion of FSH can be significantly regulated by the balance of activin and inhibin, with follistatin playing a role by inhibiting activin and enhancing inhibin activity. Within the ovarian follicle, activin and inhibin influence growth and development by modulating theca and granulosa responses to the gonadotropins.**

The inhibin-activin family of peptides (which also includes AMH and TGF- $\beta$ ) inhibits cell growth and can be considered as a class of tumor-suppressor proteins. Mice have been generated that are deficient in the inhibin-alpha-subunit gene.<sup>115</sup> The mice that are homozygous and lack inhibin are susceptible to the development of gonadal stromal tumors that appear after normal sexual differentiation and development. Thus, the alpha-inhibin gene is a specific tumor-suppressor gene for the gonads. A contributing factor to this tumor development could be the high FSH levels associated with the deficiency in inhibin.

## Growth Factors

Growth factors are polypeptides that modulate cell proliferation and differentiation,

operating through binding to specific cell membrane receptors. They are not classic endocrine substances; they act locally and function in paracrine and autocrine modes. There are multiple growth factors, and most cells contain multiple receptors for the various growth factors.

## **Insulin-Like Growth Factors**

The insulin-like growth factors (IGFs) (also called somatomedins) are peptides that have structural and functional similarity to insulin and mediate growth hormone action.<sup>149</sup> IGF-I and IGF-II are single chain polypeptides containing three disulfide bonds. IGF-I is encoded on the long arm of chromosome 12 and IGF-II on the short arm of chromosome 11 (which also contains the insulin gene). The genes are subject to a variety of promoters, and thus differential regulation can govern ultimate actions.

IGF-I mediates the growth-promoting actions of growth hormone. The majority of circulating IGF-I is derived from growth hormone-dependent synthesis in the liver. However, IGF-I is also synthesized in many tissues where production can be regulated in conjunction with growth hormone or **independently** by other factors.

IGF-II has little growth hormone dependence. It is believed to be important in fetal growth and development. Both IGFs induce the expression of cellular genes responsible for cellular proliferation and differentiation.

## **Insulin-like Growth Factor–Binding Proteins**

There are six known nonglycosylated peptides that function as IGF-binding proteins (IGFBPs), IGFBP-1 to IGFBP-6.<sup>150</sup> These binding proteins serve to carry the IGFs in serum, prolong half-lives and regulate tissue effects of the IGFs. The regulating action appears to be due to binding and sequestering of the IGFs, preventing their access to the cell membrane surface receptors, and, thus, not permitting the synergistic actions that result when gonadotropins and growth factors are combined. The IGFBPs may also exert direct actions on cellular functions, independently of growth factor functions. IGFBP-1 is the principal binding protein in the amniotic fluid, whereas IGFBP-3 is the main binding protein in serum, and its synthesis, which occurs primarily in the liver, is dependent on growth hormone. Circulating levels of IGFBP-3 reflect the total IGF concentration (IGF-I plus IGF-II) and carry at least 90% of the circulating IGFs. The IGFBPs change with age (decreasing levels of IGFBP-3) and during pregnancy (decreasing IGFBP-3 due to a circulating protease unique to pregnancy). IGFBPs do not bind insulin.

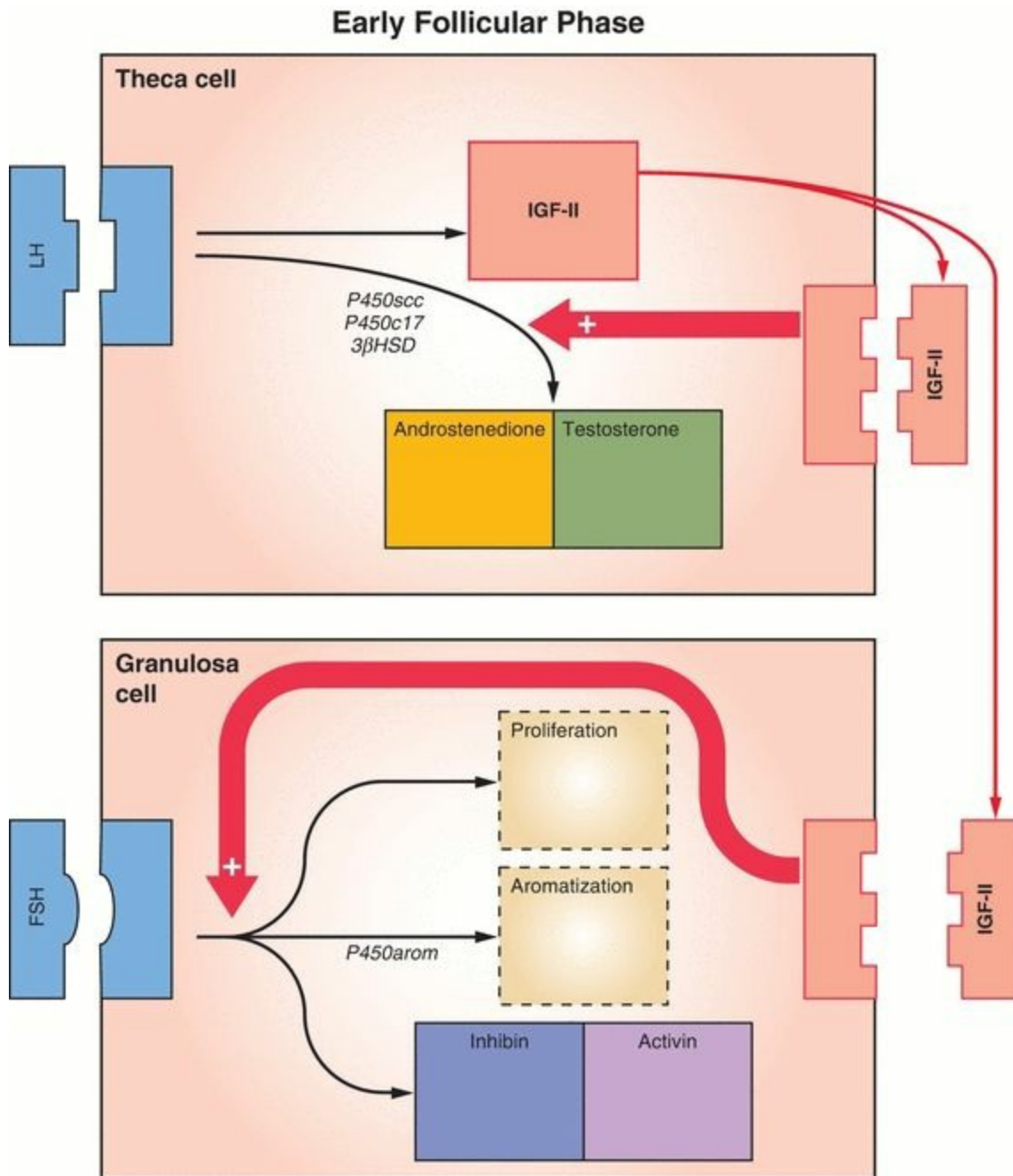
## **Insulin-like Growth Factor Receptors**

The Type I receptor preferentially binds IGF-I and can be called the IGF-I receptor. The

Type II receptor in a similar fashion can be called the IGF-II receptor. IGF-I also binds to the insulin receptor but with low affinity. Insulin binds to the IGF-I receptor with moderate affinity. The IGF-I receptor and the insulin receptor are similar in structure: tetramers composed of two alpha-subunits and two beta-subunits linked by disulfide bonds. The intracellular component of the beta-subunit is a tyrosine kinase that is activated by autophosphorylation. The IGF-II receptor does not bind insulin. It is a single chain glycoprotein, with 90% of its structure extending extracellularly. This receptor functions as a receptor coupled to a G protein. The physiologic effects of IGF-I are mediated by its own receptor, but IGF-II can exert its actions via both receptors. Indeed, the IGF-I receptor binds IGF-I and IGF-II with equal affinity. In human cells, the IGF-I receptor and IGF-II receptor are present in theca and granulosa cells and in luteinized granulosa cells. Ovarian stromal tissue contains IGF-I receptors.

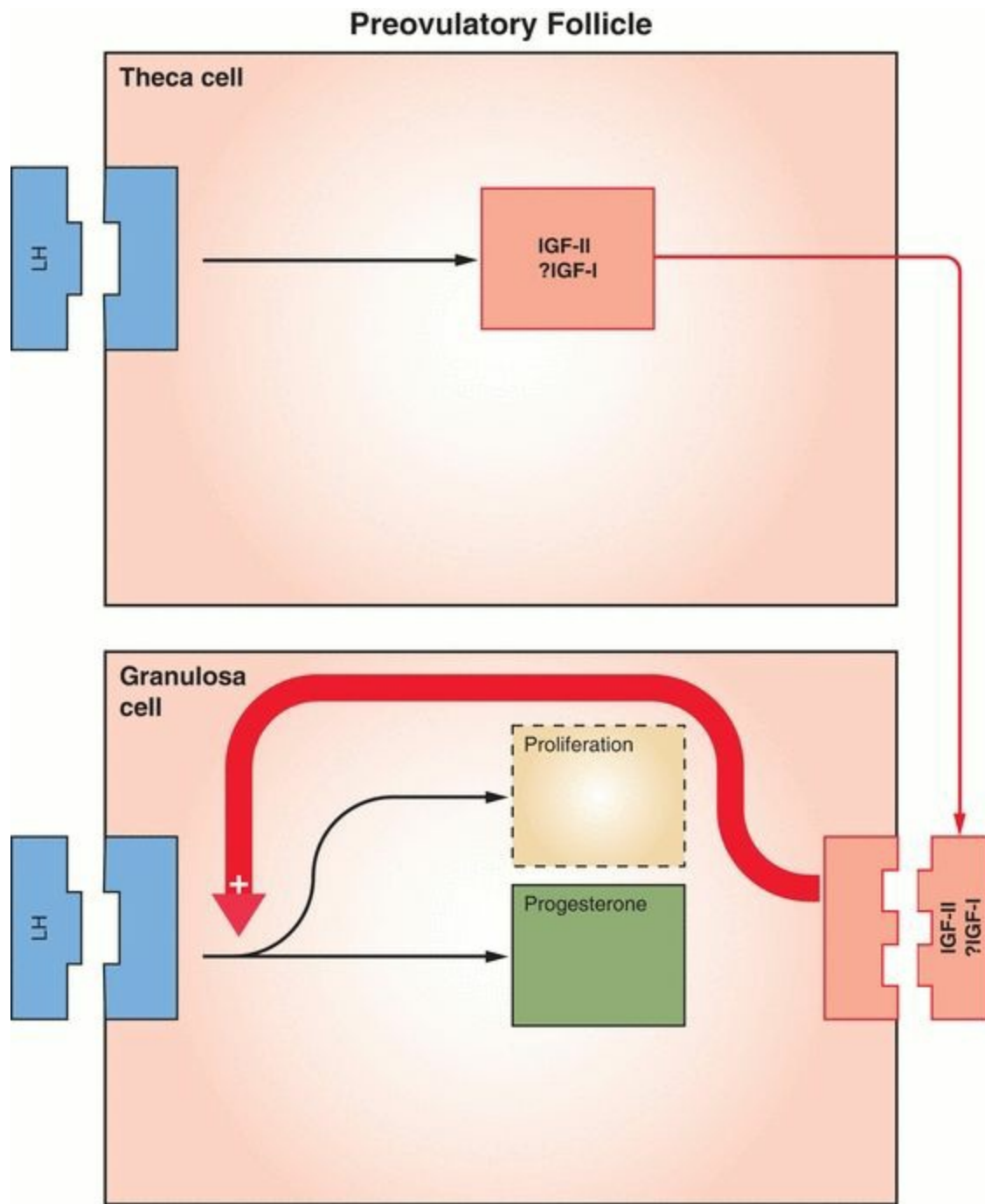
### The Ovarian Actions of IGFs

IGF signaling is recognized to play critical roles in processes of follicular development, growth and for steroidogenesis (**Figures 5.6, 5.7, 5.8**). IGF-I has been demonstrated to stimulate the following events in ovarian theca and granulosa cells: DNA synthesis, steroidogenesis, aromatase activity, LH receptor synthesis, and inhibin secretion. IGF-II stimulates granulosa mitosis. In human ovarian cells, IGF-I, in synergy with FSH, stimulates protein synthesis and steroidogenesis. After LH receptors appear, IGF-I enhances LH-induced progesterone synthesis and stimulates proliferation of granulosa-luteal cells. IGF-I, in synergy with FSH, is very active in stimulating aromatase activity in the preovulatory follicles. Thus, IGF-I can be involved in both estradiol and progesterone synthesis.

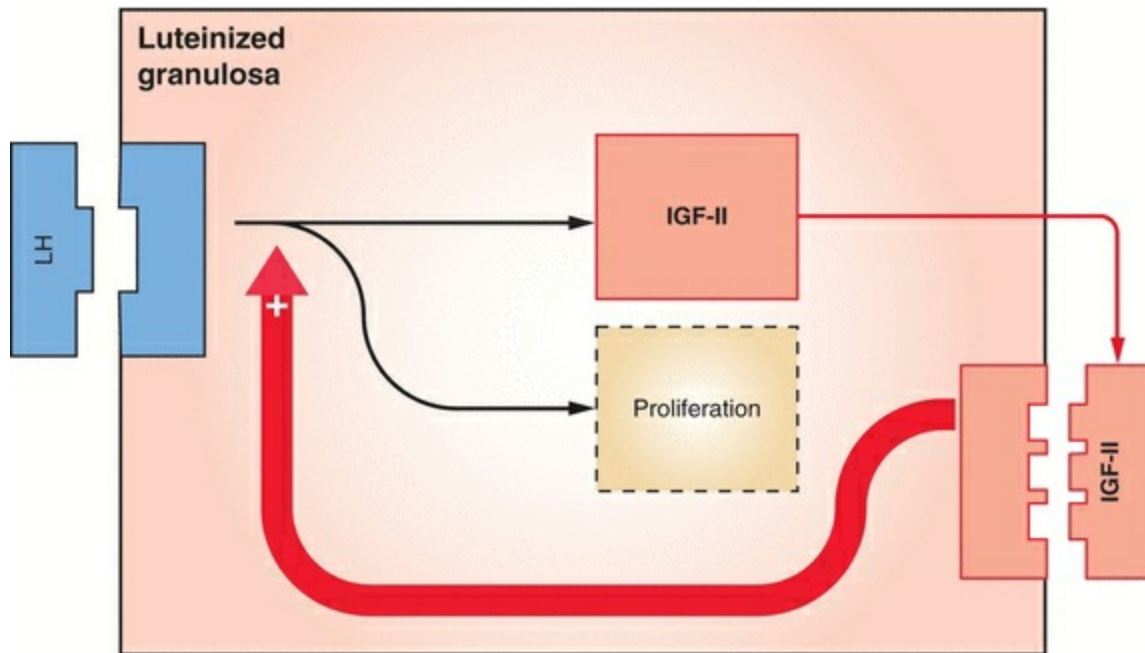


**FIGURE 5.6**





**FIGURE 5.7**



**FIGURE 5.8**

In animal experiments, synthesis of IGF-I by the granulosa cells is dependent upon FSH but enhanced by estradiol. Growth hormone also acts synergistically with FSH and estradiol to increase IGF synthesis. The story becomes confused when the many growth factors and regulators are studied, because of their various stimulating and inhibiting effects. In the rat, the granulosa cell is the major site for IGF-I gene expression, which is active only prior to ovulation. It is not detected in atretic follicles or in corpora lutea. IGF-II gene expression appears to be limited to the theca and interstitial cells in the rat. However, the site of IGF expression is different in primates.

In studies with human ovarian tissue, IGF-II is highly expressed in both theca cells and granulosa cells; however, the level is highest in the granulosa and increases with growth of the follicle.<sup>151,152</sup> IGF-II is also synthesized by luteinized granulosa and appears to function locally in an autocrine fashion.<sup>153</sup> These findings indicate that IGF-II is the primary IGF in the human ovary. Nevertheless, IGF-I is still a significant product of human theca cells.<sup>154</sup>

Human theca cells express mRNA transcripts that encode receptors for both IGF-I and insulin.<sup>155</sup> Because insulin and IGF-II can both activate the receptor for IGF-I, this pathway provides a method for exertion of paracrine influences on granulosa cells and autocrine activity in the theca (augmenting LH stimulation of androgen production). In vitro studies confirm that IGF-II is capable of stimulating steroidogenesis and proliferation in human theca and granulosa cells.<sup>156,157,158</sup> These actions are augmented by growth hormone, which increases IGF production and, thus, indirectly enhances

gonadotropin stimulation of ovarian follicles.<sup>159</sup>

This primate scenario is supported by finding higher levels of IGF-II, but not IGF-I, in the follicular fluid of developing follicles, with the highest levels present in dominant follicles.<sup>160</sup> The IGF levels in follicular fluid correlate with estradiol levels and undergo a further transient increase after the LH surge. There are no menstrual cycle changes in the circulating levels of IGF-I, IGF-II, IGFBP-1, or IGFBP-3; high levels in the dominant follicle are not associated with an increase in circulating levels.<sup>161</sup>

In studies with human tissue, IGFBP-1 inhibits IGF-I-mediated steroidogenesis and proliferation of the luteinized granulosa cells. Synthesis of IGFBPs by human granulosa is inhibited by FSH, IGF-I, and IGF-II.<sup>162,163</sup> These findings fit with the overall idea that the binding proteins counteract the synergism between gonadotropins and growth factors. In general, IGFBP-1 expression is found in granulosa cells of the growing follicles, IGFBP-3 in theca cells and the granulosa of the dominant follicle, and IGFBP-2, -4, and -5 in theca and granulosa of antral and atretic follicles; however, IGFBP-6 has not been found in the ovary.<sup>151</sup> The predominant binding protein in the preovulatory follicles is IGFBP-2 in the granulosa and IGFBP-3 in the theca; these increase progressively in the follicle that gains dominance and then decrease in the late follicular phase.<sup>152,164,165</sup> These patterns suggest that IGFBPs -1, -2, and -3 play a role in the growing follicles, whereas IGFBPs -2, -4, and -5 are relevant in the atretic and failing follicles. IGFBP expression in polycystic ovaries is like that seen in atretic follicles. The decrease in IGFBP-3 that occurs in dominant follicles should allow an increase in IGF levels and activity. The increase in IGFBP-2 in the failing follicles probably correlates with sequestering of IGF, depriving the follicle of an important force in gonadotropin augmentation.

Circulating levels of IGFBP-1 decrease in response to insulin, and thus circulating levels are decreased in women with anovulation and polycystic ovary syndrome who have elevated levels of insulin.<sup>166</sup> These patients also have increased circulating levels of IGF-I, probably a consequence of LH-stimulated synthesis and secretion in the theca cells. The level of IGFBP-1 in the follicular fluid from polycystic ovaries is decreased; thus, this binding protein is not playing a role inhibiting the action of IGF-I in the polycystic ovaries. The levels of IGFBPs -2 and -4 in the follicular fluid from follicles in anovulatory patients are increased (as in atretic follicles).<sup>151,167</sup> Even though these changes may play a role in anovulatory pathophysiology, they are consistent with failure in development and thus may not be etiologic factors.

IGF activity may also be modulated by the proteases that regulate the activity of the IGF-binding proteins.<sup>168</sup> Estrogen-dominant follicular fluid contains very low levels of IGFBP-4, in contrast to the high levels present in androgen-dominant follicular fluid.

The low level of IGFBP-4 in estrogen-dominant follicular fluid is associated with the presence of an IGFBP-4 specific protease. This protease would decrease IGFBP activity and enhance IGF activity, another mechanism for ensuring the success of the dominant follicle.

The IGF story is at once complex, fascinating, and compelling. However, its contribution may be facilitatory, but not essential. Laron-type dwarfism is characterized by a deficiency in IGF-I due to an abnormality in the growth hormone receptor. Despite low levels of IGF-I and high levels of IGFBP, a woman with Laron-type dwarfism responded to exogenous gonadotropin stimulation with the production of multiple, mature follicles with good estrogen production and fertilizable oocytes.<sup>169</sup> Another explanation for this observation is that IGF-II, rather than IGF-I, is the important factor in the human-dominant follicle. This possibility is supported by evidence indicating that IGF-II is the most abundant IGF in human ovarian follicles.<sup>151,152</sup> Another possibility is that the Laron-type dwarf is deficient only in growth hormone–dependent IGF-I and that ovarian IGFs are not totally dependent on growth hormone.

## Key Points: Insulin-Like Growth Factor Action in the Ovary

- IGF-II stimulates granulosa cell proliferation, aromatase activity, and progesterone synthesis.
- IGF-II is produced in theca cells, granulosa cells, and luteinized granulosa cells.
- Gonadotropins stimulate IGF production, and in animal experiments, this stimulation is enhanced by estradiol and growth hormone.
- IGF-I receptors are present in theca and granulosa cells, and only IGF-II receptors are present in luteinized granulosa.
- IGF-II activates both IGF-I and IGF-II receptors.
- The most abundant IGF in human follicles is IGF-II. In the pig and rat, the primary IGF is IGF-I.
- FSH inhibits binding protein synthesis and thus maximizes growth factor availability.

## Epidermal Growth Factor

EGF is a mitogen for a variety of cells, and its action is potentiated by other growth factors. Granulosa cells in particular respond to this growth factor in a variety of ways related to gonadotropin stimulation, including proliferation. EGF suppresses the up-

regulatory effects of FSH on its own receptor.<sup>39</sup> Amphiregulin and epiregulin, ligands that are similar to EGF, are produced in luteinized granulosa cells in response to LH and induce progesterone synthesis in the corpus luteum.<sup>170</sup>

## **Transforming Growth Factor**

TGF-alpha ( $\alpha$ ) is a structural analog of EGF and can bind to the EGF receptor. TGF-beta ( $\beta$ ) utilizes a receptor that is distinct from the EGF receptor. These factors are thought to be autocrine growth regulators. Inhibin and activin are derived from the same gene family. TGF- $\beta$ , secreted by theca cells, enhances FSH induction of LH receptors on granulosa cells, an action that is opposite that of EGF.<sup>171</sup> While this action can be viewed as a positive impact on granulosa cells, in the theca, TGF- $\beta$  has a negative action, inhibiting androgen production.<sup>172</sup> GDF-9 is a member of the TGF- $\beta$  family that originates in the oocyte and is essential for normal growth and development of the ovarian follicle.<sup>16</sup>

## **Fibroblast Growth Factor (FGF)**

This factor is a mitogen for a variety of cells and is present in all steroid-producing tissues. Important roles in the ovarian follicle include stimulation of mitosis in granulosa cells, stimulation of angiogenesis, stimulation of plasminogen activator, inhibition of FSH up-regulation of its own receptor, and inhibition of FSH-induced LH receptor expression and estrogen production.<sup>39,173</sup> These actions are opposite to those of TGF- $\beta$ .

## **Platelet-Derived Growth Factor**

This growth factor modifies cyclic AMP pathways responding to FSH, especially those involved in granulosa cell differentiation. Both platelet-derived growth factor (PDGF) and EGF may also modify prostaglandin production within the follicle.

## **Angiogenic Growth Factors**

Vascularization of the follicle is influenced by peptides in the follicular fluid, especially VEGF, a cytokine produced in granulosa cells in response to LH.<sup>174,175</sup> Luteal cells respond to human chorionic gonadotropin (hCG) with greater VEGF output, a probable mechanism contributing to the increased vascular permeability associated with ovarian hyperstimulation syndrome that can occur with exogenous gonadotropin administration (Chapter 28).<sup>176</sup> Angiopoietins bind to an endothelial receptor (Tie-2) and provide an inhibitory influence on angiogenesis. Angiopoietin-1 is the active agent, opposed by angiopoietin-2, which competes for the Tie-2 receptor on endothelial cells. Differential

expression of these angiogenic factors is involved in the coordinated growth and regression of follicles and the corpus luteum.<sup>177,178,179</sup> Injection of VEGF and angiopoietin antagonists directly into dominant follicles in the monkey interferes with both the physical process of ovulation and the subsequent function of the corpus luteum.<sup>180</sup>

## The Interleukin-1 (IL-1) System

Leukocytes are a prominent component of the ovarian follicle and a major source of interleukins. IL-1 is a member of the cytokine family of immunomediators. The human ovary contains the complete IL-1 system (ligand and receptor). In the rat, IL-1 stimulates ovarian prostaglandin synthesis and perhaps plays a role in ovulation.<sup>181</sup>

## Tumor Necrosis Factor-alpha

Tumor necrosis factor-alpha (TNF- $\alpha$ ) is also a product of leukocytes (macrophages). It very likely is a key player in the process of apoptosis, a feature of follicular atresia as well as luteolysis of the corpus luteum.

## Other Peptides

The follicular fluid is a veritable protein soup! It is composed of exudates from plasma and secretions from follicular granulosa cells. A variety of hormones can be found in the follicular fluid, as well as enzymes and peptides, which play important roles in follicular growth and development, ovulation, and modulation of hormonal responses.

Follicular fluid contains **prorenin**, the inactive precursor of renin, in a concentration that is about 12 times higher than in the plasma.<sup>182</sup> LH stimulates its synthesis in the follicle, and there is a midcycle peak in prorenin plasma levels. The circulating levels of prorenin also increase (10-fold) during the early stages of pregnancy—the result of ovarian stimulation by the rise in hCG. These increases in prorenin from the ovary are not responsible for any significant changes in the plasma levels of the active form, renin. Possible roles for this ovarian prorenin-renin-angiotensin system include stimulation of steroidogenesis to provide androgen substrate for estrogen production, regulation of calcium and prostaglandin metabolism, and stimulation of angiogenesis. This system may affect vascular and tissue functions both within and outside the ovary.

Members of the proopiomelanocortin family are found in human follicular fluid.<sup>183</sup> Follicular levels of **ACTH** and  **$\beta$ -lipotropin** remain constant throughout the cycle, but  **$\beta$ -endorphin** levels peak just before ovulation. In addition, enkephalin is present in relatively unchanging concentrations. The complete **corticotropin-releasing hormone**

(**CRH**) system, including CRH, the CRH receptor, and CRH-binding protein, is present in the theca but not in granulosa cells.<sup>184</sup> CRH inhibits LH-stimulated androgen production in theca cells, apparently by suppressing P450c17 gene expression.<sup>185</sup>

## Antimüllerian hormone

A member of the TGF- $\beta$  family, like inhibin and activin, AMH is produced by granulosa cells and may play a role in oocyte maturation (it inhibits oocyte meiosis) and follicular development.<sup>186,187</sup> AMH directly inhibits proliferation of granulosa and luteal cells, as well as EGF-stimulated proliferation. Its paracrine function may be to suppress growth of all but the dominant follicle in each cycle.<sup>70</sup> Circulating level of AMH is highest in the late follicular phase, peaking simultaneously with inhibin A just before ovulation.<sup>188</sup> Experimental evidence suggests that the source of the AMH is the entire cohort of growing follicles except for the dominant follicle, and thus, the circulating level correlates with follicle number and potential for fertility.<sup>189,190</sup> With aging and a decrease in the number of follicles, AMH levels decline. AMH can be measured on any day in an individual's menstrual cycle, as there is minimal variability across the different phases of the menstrual cycle. While previously believed that AMH levels remain unaffected by use of steroid contraception, recent evidence demonstrates that circulating AMH levels may be falsely suppressed in long-term users of hormonal contraceptives.<sup>75,76</sup>

Follicular fluid prevents resumption of meiosis until the preovulatory LH surge either overcomes or removes this inhibition. This action is attributed to **oocyte maturation inhibitor (OMI)**. **Pregnancy-associated plasma protein A**, found in the placenta, is also present in follicular fluid. It may inhibit proteolytic activity within the follicle before ovulation. **Endothelin-1** is a peptide, produced in vascular endothelial cells, which may be the substance previously known as luteinization inhibitor; endothelin gene expression is induced by the hypoxia associated with the avascular granulosa, and it inhibits LH-induced progesterone production.<sup>191</sup> It is uncertain whether **GnRH-like peptides** have a follicular role or represent sequestered GnRH. **Oxytocin** is found in preovulatory follicles and the corpus luteum. Growth hormone-binding protein is present in follicular fluid and is similar in characteristics to the same binding protein in serum.

## Key Points: Antral Follicle

- Follicular phase estrogen production is explained by the two-cell, two-gonadotropin mechanism.

- Selection of the dominant follicle is established during cycle days 5–7, and consequently, peripheral levels of estradiol begin to rise significantly by cycle day 7.
- Estradiol levels, derived from the dominant follicle, increase steadily and, through negative feedback effects, exert a progressively greater suppressive influence on FSH release.
- While directing a decline in FSH levels, the midfollicular rise in estradiol exerts a positive feedback influence on LH secretion.
- The positive action of estrogen also includes modification of the gonadotropin molecule, increasing the quality (the bioactivity) as well as the quantity of FSH and LH at midcycle.
- LH levels rise steadily during the late follicular phase, stimulating androgen production in the theca.
- A unique responsiveness to FSH allows the dominant follicle to utilize the androgen as substrate and further accelerate estrogen production through aromatization.
- FSH induces the appearance of LH receptors on granulosa cells.
- Follicular response to the gonadotropins is modulated by a variety of growth factors and autocrine-paracrine peptides.
- Inhibin B, secreted by the granulosa cells in response to FSH, directly suppresses pituitary FSH secretion.
- Activin, originating in both pituitary and granulosa, augments FSH secretion and action.



# Follicular Growth and Development in the Primate Ovary

Evidence strongly indicates that autocrine-paracrine peptides, and not estrogen, play the major role in regulating ovarian follicle growth and development in the primate. In monkey experiments, no reduction in total number or size of follicles resulted when estradiol production was effectively suppressed by treatment with an inhibitor of the aromatase enzyme system or with an inhibitor of the  $3\beta$ -hydroxysteroid dehydrogenase enzyme.<sup>192,193,194</sup> Oocyte development was not altered, although the subsequent fertilization rate was reduced by this treatment. Another argument against a major role for estrogen in follicular growth and development is the successful stimulation with gonadotropins of normal follicular growth and development in women with  $17\alpha$ -hydroxylase deficiency (an inherited disorder that prevents the production of androgens and estrogens).<sup>195,196</sup>

A nonessential role for estrogen in follicular growth and development is further supported by the response of women with a deficiency in gonadotropins to treatment with recombinant (pure) FSH.<sup>61,62,63</sup> Some aromatization occurred, perhaps using androgens originating in the adrenal glands, producing early follicular phase estradiol levels, but the usual robust steroidogenesis was impossible without the presence of LH to provide theca production of androgen substrate. Nevertheless, oocytes were retrieved, and with in vitro fertilization, pregnancy was achieved. This same response was observed in experiments that used a GnRH antagonist to produce LH-deficient monkeys and then the administration of recombinant, pure human FSH.<sup>64,65</sup>

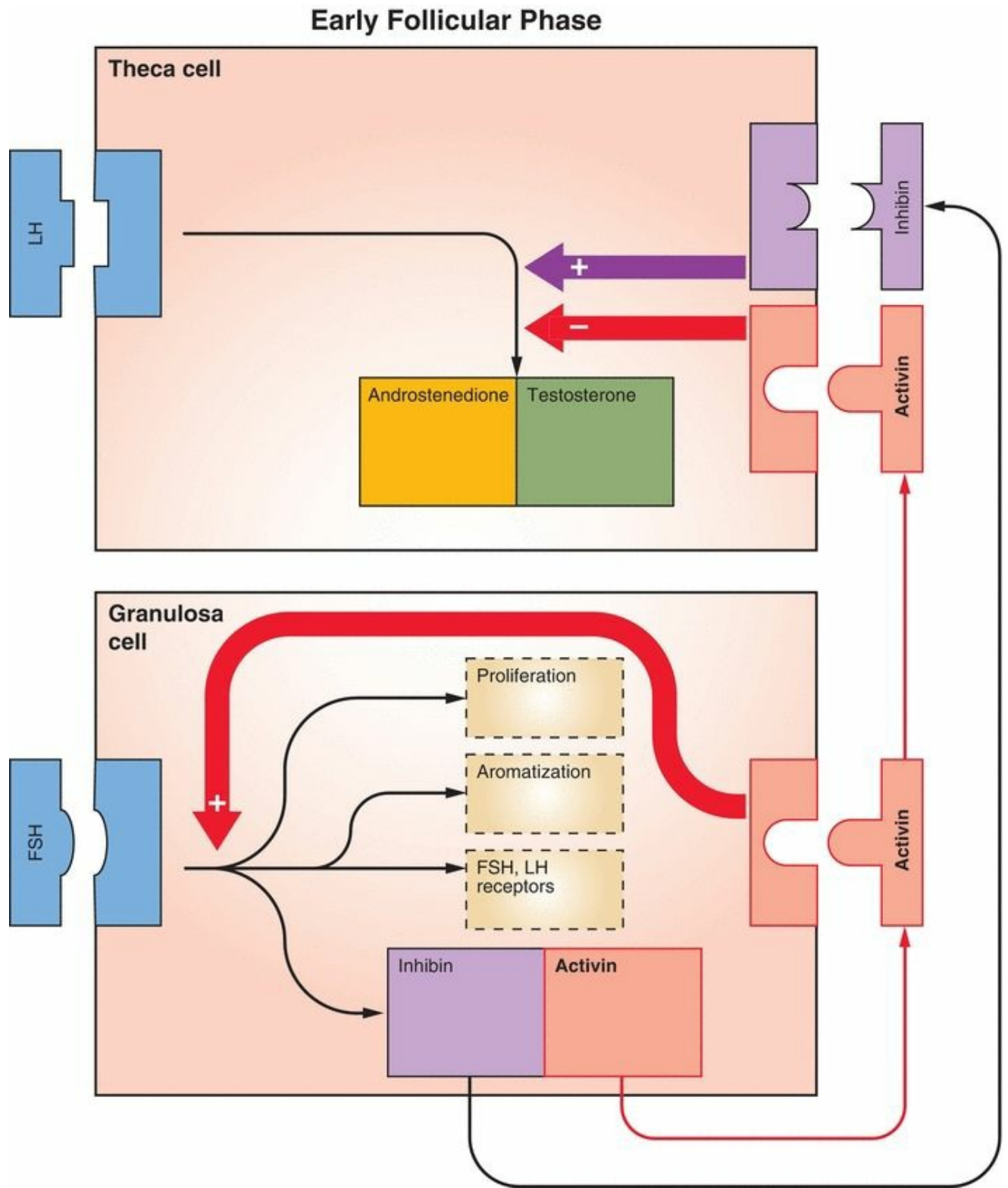
These results indicate that only FSH is required for early folliculogenesis and that in the primate, autocrine-paracrine peptides have replaced estrogen in the important role of modulating gonadotropin response. Consider the following actions that have been documented in primate ovaries:

1. Inhibin and activin regulate androgen synthesis in human theca cells. Inhibin enhances and activin suppresses the stimulatory action of LH and/or IGF-I, and inhibin can overcome the inhibitory action of activin on theca cells.<sup>138,139,140</sup>
2. In immature granulosa cells, activin augments all FSH activities, especially aromatase activity (estrogen production).<sup>114,197</sup>
3. In luteinizing granulosa cells, activin has direct mitogenic activity and suppresses steroidogenesis in response to LH, while inhibin has no effect on LH-dependent aromatase in mature granulosa cells.<sup>197,198</sup>
4. In the follicular phase, granulosa production of inhibin is under the control of FSH, but during the late follicular phase a change occurs, culminating in LH control of

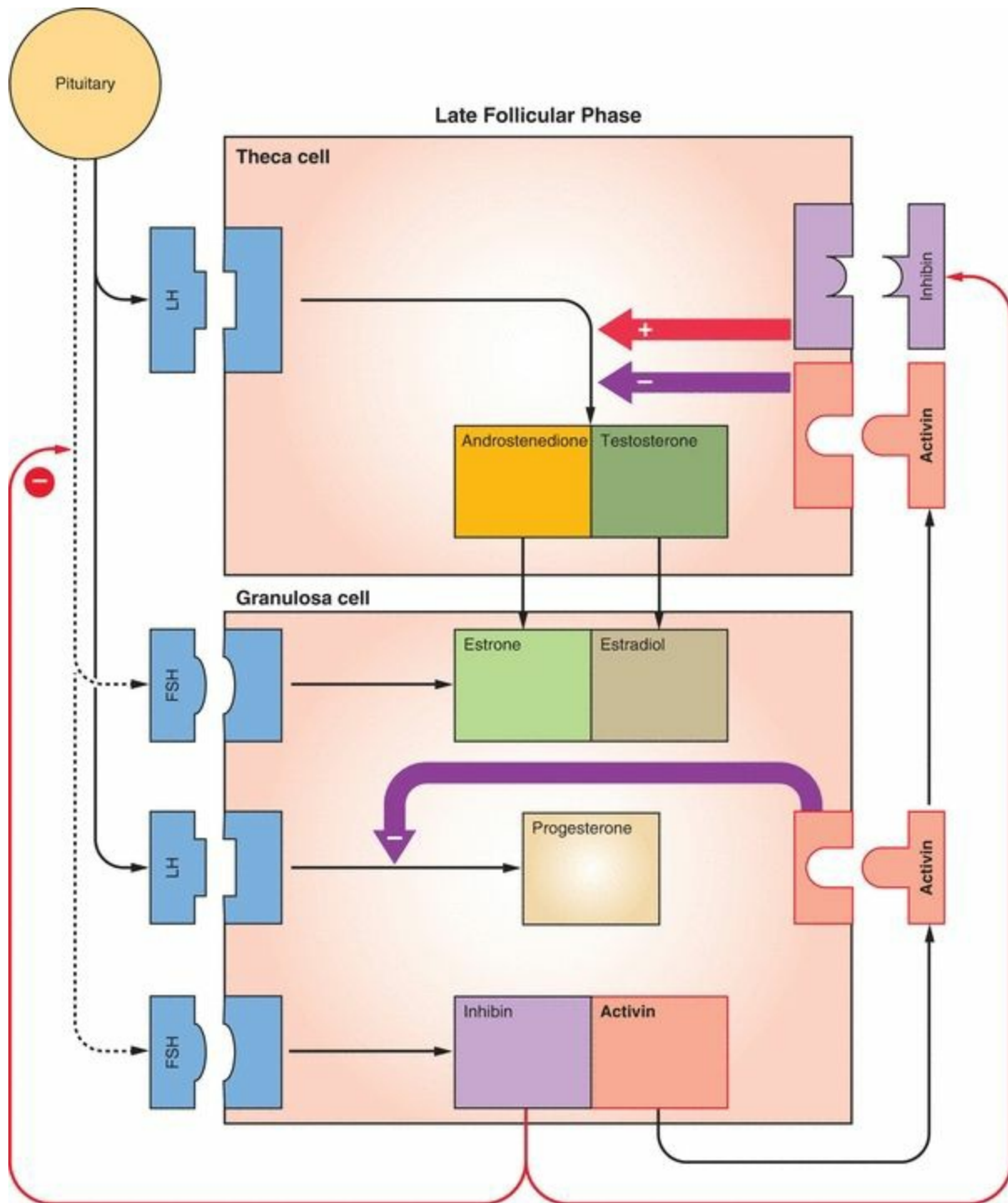
luteal synthesis of inhibin.<sup>199,200</sup>

5. As the follicle grows, activin production decreases, and inhibin production increases.<sup>201,202</sup> In addition, follistatin levels increase in the follicular fluid with increasing growth of the follicle, a mechanism for decreasing activin activity.<sup>203</sup> In the early follicular phase, FSH and estradiol enhance inhibin-B secretion, probably indirectly by increasing granulosa cell numbers, whereas late in the follicular phase, when LH levels increase, inhibin-A secretion is favored.<sup>204</sup>

These actions come together as follows. In the early follicular phase, activin produced by granulosa in immature follicles enhances the action of FSH on aromatase activity and FSH and LH receptor formation, while simultaneously suppressing theca androgen synthesis (**Figure 5.9**). In the late follicular phase, increased production of inhibin (specifically inhibin B) by the granulosa (and decreased activin) promotes androgen synthesis in the theca in response to LH and IGF-II to provide substrate for even greater estrogen production in the granulosa (**Figure 5.10**). In the mature granulosa of the dominant preovulatory follicle, activin serves to prevent premature luteinization and progesterone production.



**FIGURE 5.9**

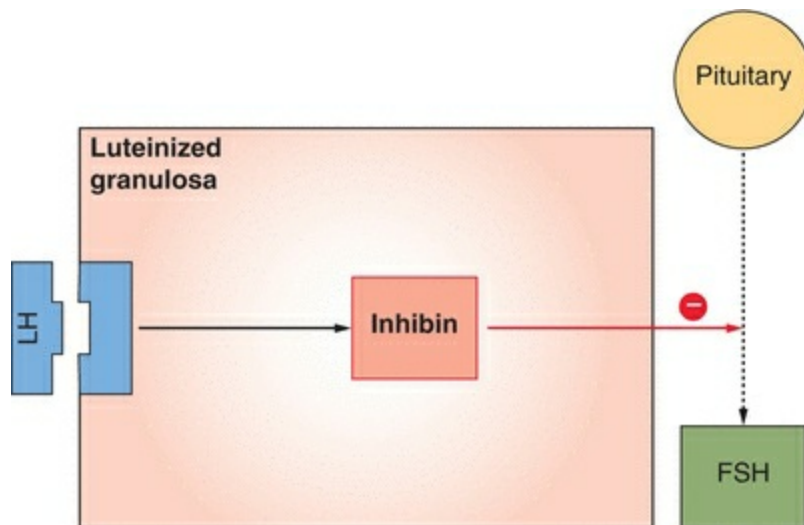


**FIGURE 5.10**

The successful follicle is the one that acquires the highest level of aromatase activity and LH receptors in response to FSH and is characterized by the highest estrogen (for central feedback action) and the greatest inhibin production (for both local and central actions). This accomplishment occurs in synchrony with the appropriate activin expression. The highest level of gene activity encoding activin is found in immature

antral follicles and the lowest level in the preovulatory follicles. Thus, activin proteins (which enhance FSH activity) are produced in greatest amounts early in follicular development to enhance follicle receptivity to FSH. As with circulating levels of inhibin, inhibin B is the predominant inhibin in the follicular fluid of preantral follicles, and inhibin A increases when follicles become large and mature.<sup>205,206,207</sup> Inhibin synthesis and secretion during the follicular phase are regulated by FSH and growth factors.<sup>208</sup>

The right concentration of androgens in granulosa cells promotes aromatase activity and inhibin production and, in turn, inhibin promotes LH stimulation of theca androgen synthesis. With development of the follicle, inhibin expression (specifically inhibin A) comes under the control of LH. A key to successful ovulation and luteal function is the conversion of inhibin production to LH responsiveness to maintain FSH suppression centrally (**Figure 5.11**) and enhancement of LH action locally.



**FIGURE 5.11**

Responses of ovarian follicles to exogenous FSH and LH stimulation for in vitro fertilization indicate that the final maturation and function of the dominant follicle prior to ovulation are significantly influenced by LH.<sup>84</sup> Final maturation of the dominant follicle and the health of the oocyte are optimized by the required presence of a threshold level of LH.<sup>66,86,87,209</sup>

A lesser role is assigned to the insulin-like growth factors in view of the successful production of multiple, estrogen-producing follicles, which yielded fertilizable oocytes in a woman with IGF-I deficiency treated with gonadotropins.<sup>169</sup> The growth factors assume an important, but perhaps not essential, role as facilitating agents. However,

successful pregnancy in a woman with IGF-I deficiency may indicate the greater importance of IGF-II.

## Key Points: Primate Ovarian Follicle

- FSH has multiple activities in the granulosa cell: stimulating aromatization of androgens to estrogens, increasing granulosa cell content of FSH and LH receptors, stimulating proliferation of granulosa cells, and producing autocrine-paracrine factors, especially activin and inhibin.
- In the granulosa of the early follicular phase, activin augments FSH activities: FSH receptor expression, aromatization, inhibin/activin production, and LH receptor expression. In the theca, activin suppresses androgen production, allowing the emergence of an estrogen-dominant microenvironment.
- Later in the follicular phase, inhibin enhances LH stimulation of androgen synthesis in the theca to provide substrate for aromatization to estrogen in the granulosa, making available the large amount of estrogen necessary for local follicular actions and to trigger the LH surge.
- Inhibin B is secreted by the granulosa cells into the circulation, where it acts in a classic endocrine fashion to suppress FSH secretion by the pituitary gland, an important method to ensure the dominance of a single follicle.
- With the appearance of LH receptors, inhibin production by the granulosa is maintained as it comes under the control of LH.
- Late in the follicular phase, final follicular maturation to yield the most favorable level of steroidogenesis and an oocyte with the best viability requires the presence of a threshold level of LH.
- All functions are modulated by an army of growth factors, and IGF-II may be especially important.

# The Preovulatory Follicle

Granulosa cells in the preovulatory follicle enlarge and acquire lipid inclusions while the theca becomes vacuolated and richly vascular, giving the preovulatory follicle a hyperemic appearance. The oocyte proceeds in meiosis, approaching completion of its reduction division.

Approaching maturity, the preovulatory follicle produces increasing amounts of estrogen. During the late follicular phase, estrogens rise slowly at first, then rapidly, reaching a peak approximately 24–36 hours prior to ovulation.<sup>210</sup> The onset of the LH surge occurs when the peak levels of estradiol are achieved.<sup>211</sup> In providing the ovulatory stimulus to the selected follicle, the LH surge seals the fate of the remaining follicles, with their lower estrogen and FSH content, by further increasing androgen superiority.

Acting through its own receptors, LH promotes luteinization of the granulosa in the dominant follicle, resulting in the production of progesterone. The LH receptor, once expressed, inhibits further cell growth and focuses the cell's energy on steroidogenesis (these actions are enhanced by IGF).<sup>212</sup> An increase in progesterone can be detected in the venous effluent of the ovary bearing the preovulatory follicle as early as day 10 of the cycle.<sup>77</sup> This small but significant increase in the production of progesterone in the preovulatory period has immense physiologic importance. Prior to the emergence of this follicular progesterone, the circulating levels of progesterone are of adrenal origin.<sup>213</sup>

Progesterone receptors begin to appear in the granulosa cells of the dominant follicle in the periovulatory period.<sup>88</sup> The traditional view has been that progesterone receptors are expressed in response to estrogen through an estrogen-receptor-mediated mechanism; however, this is not the case. Experimental data in the monkey provide excellent evidence that LH stimulates progesterone receptor expression in the granulosa cells.<sup>214</sup> In vitro data with human cells suggest that the preovulatory progesterone and progesterone receptor expression directly inhibit granulosa cell mitosis, probably explaining the limitation of granulosa cell proliferation as these cells gain LH receptors.<sup>215</sup>

Progesterone affects the positive feedback response to estrogen in both a time- and dose-dependent manner. When introduced after adequate estrogen priming, progesterone facilitates the positive feedback response of estrogen by direct action at the level of the pituitary, and in the presence of subthreshold levels of estradiol, it can induce a characteristic LH surge.<sup>216,217</sup> This ability of progesterone to induce an LH surge can explain the surprising onset of ovulation occasionally observed in an anovulatory, amenorrheic woman following administration of a progestin challenge. However, when

administered before the estrogen stimulus, or in high doses (achieving a blood level >2 ng/mL), progesterone blocks the midcycle LH surge.

Thus, appropriately low levels of progesterone derived from the maturing follicle contribute to the precise synchronization of the midcycle surge. In addition to its facilitator action on LH, progesterone at midcycle is also responsible for the FSH surge.<sup>217</sup> This action of progesterone can be viewed as a further step in ensuring completion of FSH action on the preovulatory follicle, especially making sure that a full complement of LH receptors is in place in the granulosa layer. In certain experimental situations, incremental estradiol alone can elicit simultaneous surges of LH and FSH, suggesting that progesterone certainly enhances the effect of estradiol but may not be obligatory for the occurrence of the midcycle gonadotropin surge.<sup>218</sup> Nevertheless, blockade of midcycle progesterone synthesis or activity in the monkey impaired the processes of ovulation and luteinization.<sup>219</sup> These actions of estrogen and progesterone in modulating gonadotropin release require the presence and action of GnRH.

The preovulatory period is associated with a rise in plasma levels of 17-hydroxyprogesterone (17-OHP). This steroid precursor does not appear to have a role in cycle regulation, and its appearance in the blood simply represents the secretion of an intermediate product. The preovulatory rise in 17-OHP reflects LH stimulation of the P450<sub>scc</sub> and P450<sub>c17</sub> enzymes that are critical for the production of androgens by the theca, which then get aromatized to estrogen by the granulosa. After ovulation, some of the theca cells become luteinized as part of the corpus luteum and lose the ability to express P450<sub>c17</sub>. Other luteinized theca cells retain P450<sub>c17</sub> activity and are believed to continue to produce androgens for aromatization to estrogens.

For the lesser follicles that fail to achieve full maturity and undergo atresia, the adjoining theca returns to its original role as a component of the ovarian stromal tissue, retaining, however, an ability to respond to LH with P450 activity and steroid production. Because the hormonal products of theca tissue are androgens, the increase in stromal tissue in the late follicular phase is associated with a rise in circulating androgen levels at midcycle, when a 15% increase in androstenedione and a 20% increase in testosterone levels can occur.<sup>220</sup> This response is enhanced by the late follicular phase rise in inhibin, known to augment LH stimulation of androgen production in theca cells.

Increasing androgen production in the preovulatory stage in the cycle may serve two purposes: (1) a local role within the ovary to enhance the process of atresia of the lesser follicles and (2) a systemic effect to stimulate libido nearing the time of ovulation.

Intraovarian androgens accelerate granulosa cell death and follicular atresia. The specific mechanism for this action is unclear, although it is attractive to suspect an



interference with estrogen and the autocrine-paracrine factors in enhancing FSH activity. Therefore, androgens may play a regulatory role in ensuring that only a dominant follicle reaches the point of ovulation.

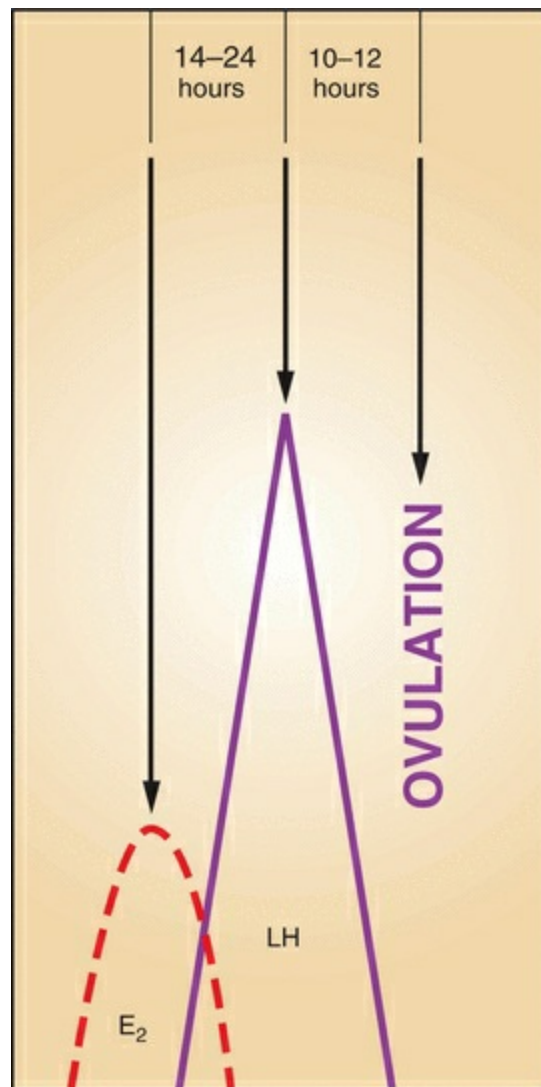
It is well known that libido can be stimulated by androgens. If the midcycle rise in androgens affects libido, then an increase in sexual activity should coincide with this rise. Early studies failed to demonstrate a consistent pattern in coital frequency in women because of the effect of male partner initiation. If only sexual behavior initiated by women is studied, a peak in female-initiated sexual activity is seen during the ovulatory phase of the cycle.<sup>221</sup> The coital frequency of married couples has also been noted to increase at the time of ovulation.<sup>222</sup> Therefore, the midcycle rise in androgens may serve to increase sexual activity at the time most likely to achieve pregnancy.

## Key Points: Preovulatory Follicle

- Estrogen production becomes sufficient to achieve and maintain peripheral threshold concentrations of estradiol that are required to induce the LH surge.
- Acting through its receptors, LH initiates luteinization and progesterone production in the granulosa layer.
- The preovulatory rise in progesterone facilitates the positive feedback action of estrogen at the level of pituitary, which results in the LH surge. Preovulatory rise in progesterone may also be required to induce the midcycle FSH peak.
- A midcycle increase in local and peripheral androgens occurs, derived from the theca tissue of the lesser, unsuccessful follicles.

# OVULATION

The preovulatory follicle, through the elaboration of estradiol, provides its own ovulatory stimulus. Considerable variation in timing exists from cycle to cycle, even in the same woman. A reasonable and accurate estimate places ovulation approximately 10–12 hours after the LH peak and 24–36 hours after peak estradiol levels are attained (**Figure 5.12**).<sup>210,223</sup> The onset of the LH surge appears to be the most reliable indicator of impending ovulation, occurring 34–36 hours prior to follicle rupture.<sup>224</sup> A threshold of LH concentration must be maintained for 14–27 hours in order for full maturation of the oocyte to occur.<sup>225</sup> Usually, the LH surge lasts 48–50 hours.<sup>224</sup>



**FIGURE 5.12**

Over recent decades, increasing utilization of in vitro fertilization in infertility

management has allowed clarity in our understanding of the timeline of ovarian events following an induced LH surge. Spontaneous LH surge tends to occur at approximately 3 A.M., beginning between midnight and 8:00 A.M. in over two-thirds of women.<sup>98</sup> Seasonal variation in timing of LH surge is recognized.<sup>226</sup> Ovulation occurs primarily in the morning during spring, and primarily in the evening during autumn and winter. From July to February in the Northern Hemisphere, about 90% of women ovulate between 4 and 7 P.M.; during Spring, 50% of women ovulate between midnight and 11 A.M.

Most of the studies have concluded that ovulation occurs more frequently (about 55% of the time) from the right ovary compared to the left. Furthermore, oocytes from the right ovary are suggested to have a higher potential for pregnancy compared to those from the left side.<sup>227</sup> The side of ovulation does not affect cycle characteristics, but cycles with short follicular phases tend to be followed by contralateral ovulation, and ovulation occurs randomly following cycles with a long follicular phase.<sup>228,229</sup> Ovulation alternating between the two ovaries predominates in younger women, but after 30 years of age, ovulations occur more frequently from the same ovary; however, throughout the reproductive years, more ovulations occur from the right ovary.<sup>229</sup> Contralateral ovulation favors pregnancy more than ipsilateral ovulation, and ipsilateral ovulation increases with increasing age and decreasing fertility.<sup>230</sup>

The gonadotropin surge initiates a cascade of events that ultimately lead to ovulation, the physical release of the oocyte, and its cumulus mass of granulosa cells.<sup>231</sup> Ovulation is not an explosive event; therefore, a complex series of changes must occur, which cause the final maturation of the oocyte and the decomposition of the collagenous layer of the follicular wall with its subsequent breakdown followed by release of the follicular contents.<sup>232</sup>

The LH surge initiates the resumption of meiosis in the oocyte (meiosis is not completed until after the sperm has entered and the second polar body is released), luteinization of granulosa cells and progesterone production, expansion of the cumulus, and the synthesis of prostaglandins and other eicosanoids essential for follicle rupture. Premature oocyte maturation and luteinization are prevented by local factors.

An LH-induced increase in cyclic AMP occurs within the follicle just prior to ovulation. Cyclic AMP is transferred from the granulosa cells to the oocyte via the gap junction network, and thus a reduction in cyclic AMP occurs when LH causes a breakdown of the gap junctions. This results in a decrease in the local inhibitory action of OMI and luteinization inhibitor (LI). The OMI originates from granulosa cells, and its activity depends upon an intact cumulus oophorus. LI may be endothelin-1, a product of vascular endothelial cells.<sup>190</sup> Locally produced activin suppresses progesterone production by the luteal cells, providing yet another means of preventing premature

luteinization.<sup>233,234</sup> The propagation of LH-induced changes throughout the follicle depends on growth factors and their receptors, especially members of the EGF-like family, specifically LH-induced factors named amphiregulin, epiregulin, and betacellulin.<sup>235</sup> Disruption of this pathway interferes with oocyte resumption of meiosis and ovulation.

There is abundant evidence that the oocyte exerts control over granulosa functions, affecting both metabolism and proliferation through the secretion of proteins in the TGF- $\beta$  family.<sup>49,236,237,238,239</sup> These proteins include inhibin, activin, AMH, BMPs, and GDF9, which must be secreted in their active forms after processing of precursor proteins by proteases. The production of the active proteins is regulated by an interaction of the signaling proteins from the oocyte and the granulosa cells, determined by changing responsiveness to FSH as the components of the ovarian follicle develop and differentiate.<sup>240</sup> The differentiation and maintenance of the cumulus cells from the preantral granulosa cells are under the direction of the oocyte.<sup>241,242</sup>

The cumulus oophorus differs from other granulosa cells, lacking in LH receptors and progesterone production; FSH-induced LH receptor expression is suppressed in the contiguous granulosa cells by the oocyte. The oocyte enables cumulus cells to respond to the gonadotropin-induced physical and biochemical changes just before ovulation. The local factors that prevent premature oocyte maturation and luteinization are probably under control of the oocyte. One mediator of this control system is nitric oxide, which maintains the gap junction system of communication.<sup>243</sup> Nitric oxide resists LH-induced resumption of oocyte meiosis and breakdown of the gap junction network until the massive LH surge overcomes this resistance and communication between the oocyte and the follicular cells is interrupted.

With the LH surge, levels of progesterone in the follicle continue to rise, up until the time of ovulation. The progressive rise in progesterone may act to terminate the LH surge as a negative feedback effect is exerted at higher concentrations. In addition to its central effects, progesterone increases the distensibility of the follicle wall. A change in the elastic properties of the follicular wall is necessary to accommodate the rapid increase in follicular fluid volume, which occurs just prior to ovulation, unaccompanied by any significant change in intrafollicular pressure. FSH, LH, and progesterone stimulate the activity of proteolytic enzymes, resulting in digestion of collagen in the follicular wall and increasing its distensibility. The escape of the ovum is associated with degenerative changes of the collagen in the follicular wall so that just prior to ovulation the follicular wall becomes thin and stretched. The gonadotropin surge also releases histamine, and histamine alone can induce ovulation in some experimental models.

The proteolytic enzymes are activated in an orderly sequence.<sup>244</sup> The granulosa and

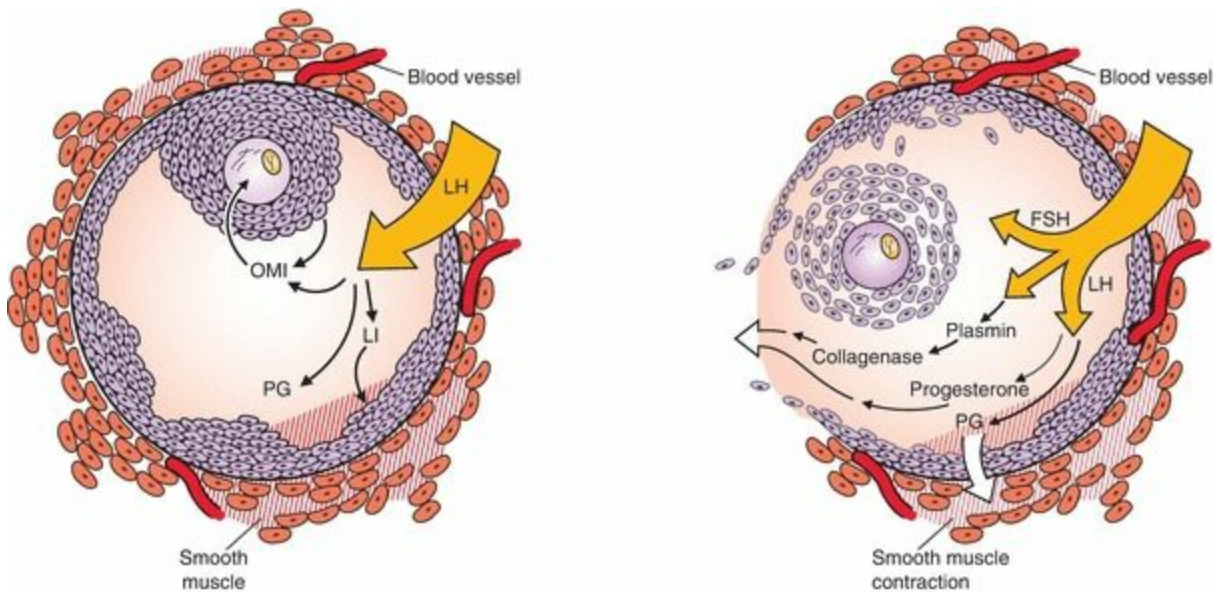
theca cells produce plasminogen activator in response to the gonadotropin surge. Plasminogen is activated by either of two plasminogen activators: tissue-type plasminogen activator and urokinase-type plasminogen activator. These activators are encoded by separate genes and are also regulated by inhibitors.

Plasminogen activators produced by granulosa cells activate plasminogen in the follicular fluid to produce plasmin. Plasmin, in turn, generates active collagenase to disrupt the follicular wall. In rat models, plasminogen activator synthesis is triggered by LH stimulation (as well as growth factors and FSH), while plasminogen inhibitor synthesis is decreased.<sup>245</sup> Thus, before and after ovulation, the inhibitor activity is high, while just at ovulation, activator activity dominates and the inhibitors are at a nadir. A coordinated molecular regulation of these factors is necessary for the complex sequence of events result in ovulation. Plasminogen activator synthesis in granulosa cells is expressed only at a precise preovulatory stage in response to LH. The inhibitor system, which is very active in the theca and interstitial cells, prevents inappropriate activation of plasminogen and disruption of growing follicles. The inhibitor system has been demonstrated to be present in human granulosa cells and preovulatory follicular fluid and to be responsive to paracrine substances, EGF and interleukin-1 $\beta$ .<sup>246,247,248</sup> Physical migration of the preovulatory follicle to the surface of the ovary is an important step in that the exposed surface of the follicle is now prone to rupture because it is now separated from cells rich in the plasminogen inhibitor system. Ovulation is the result of proteolytic digestion of the follicular apex, a site called the stigma. The matrix metalloproteinase (MMP) enzymes and their endogenous inhibitors, tissue inhibitors of metalloproteinases (TIMPs), are increased in response to LH and progesterone and are also involved in this event.<sup>249</sup>

In the rat, the gene that encodes for plasminogen activator contains a promoter region, which has several sequences for known transcription factors, such as the cyclic AMP-responsive element (CRE). The activation of this CRE (which involves a CRE-binding protein) requires FSH stimulation. Thus, both gonadotropins appear to be involved in this process. Studies in the monkey indicate that the activation of plasminogen activator is mediated by prostaglandin E<sub>2</sub>.<sup>250</sup>

Prostaglandins E<sub>2</sub> and F<sub>2 $\alpha$</sub> , but mainly prostaglandin E<sub>2</sub>, and other eicosanoids (especially HETEs, hydroxyeicosatetraenoic acids) increase markedly in the preovulatory follicular fluid in response to the LH surge, reaching a peak concentration at ovulation.<sup>251,252,253</sup> Prostaglandin synthesis is stimulated by interleukin-1 $\beta$ , implicating this cytokine in ovulation.<sup>254</sup> Inhibition of cyclooxygenase-2 (COX-2)-mediated synthesis of these products from arachidonic acid blocks follicle rupture without affecting the other LH-induced processes of luteinization and oocyte maturation.<sup>255,256,257</sup>

Prostaglandins act to free proteolytic enzymes within the follicular wall; HETEs may promote angiogenesis and hyperemia (an inflammatory-like response).<sup>250,252,258</sup> LH and PGE<sub>2</sub> both activate the EGF-like signaling pathway that leads to cumulus expansion and resumption of oocyte meiosis.<sup>259</sup> Prostaglandins may also contract smooth muscle cells that have been identified in the ovary, thereby aiding the extrusion of the oocyte-cumulus cell mass from the ruptured follicle (**Figure 5.13**). **This ovulatory role of prostaglandins is so well demonstrated that infertility patients should be advised to avoid the use of drugs that inhibit prostaglandin synthesis.**<sup>257,260,261</sup>



**FIGURE 5.13**

A large number of leukocytes enter the follicle prior to ovulation. Neutrophils are a prominent feature in the theca compartment of both healthy and atretic antral follicles.<sup>262</sup> The accumulation of leukocytes is mediated by chemotactic mechanisms of the interleukin system.<sup>263</sup> However, ovulation does not depend on these invading immune cells for the expression of the inflammatory-like response associated with ovulation. Ovarian follicular cells themselves in response to LH express the genes involved with immune responses, resulting in the release of the host of products that affect the cellular reactions associated with ovulation and the remodeling process that leads to the corpus luteum.<sup>264</sup>

Estradiol levels plunge as LH reaches its peak. This may be a consequence of LH-mediated down-regulation of its own receptors on the periovulatory follicle. Theca tissue derived from healthy antral follicles exhibits marked suppression of steroidogenesis when exposed to high levels of LH, whereas exposure over a low range

stimulates steroid production. The low midcycle levels of progesterone exert an inhibitory action on further granulosa cell multiplication, and the drop in estrogen may also reflect this local follicular role for progesterone. Finally, estrogen can exert an inhibitory effect on P450c17, a direct action on the gene that is not receptor mediated.

The granulosa cells that are attached to the basement membrane and enclose the follicle become luteal cells. The cumulus granulosa cells are in immediate proximity and are attached to the oocyte. In the mouse, the cumulus cells are metabolically linked to the oocyte and respond to the FSH surge by secreting hyaluronic acid that disperses the cumulus cells prior to ovulation. This hyaluronic acid response depends upon maintenance of the link with the oocyte, indicating the secretion of a supporting factor. The oocyte further secretes factors that promote granulosa cell proliferation and maintain the structural organization of the follicle.<sup>265</sup> While FSH stimulates mural granulosa cell proliferation, its effect on the cumulus cells is the opposite; proliferation of the cumulus cells is suppressed by FSH.

The FSH peak, partially and perhaps totally dependent on the preovulatory rise of progesterone, has several functions. Plasminogen activator production is sensitive to FSH as well as LH. Expansion and dispersion of the cumulus cells allows the oocyte-cumulus cell mass to become free-floating in the antral fluid just before follicle rupture. The process involves the deposition of a hyaluronic acid matrix, the synthesis of which is stimulated by FSH. Finally, an adequate FSH peak ensures an adequate complement of LH receptors on the granulosa layer. It should be noted that a shortened or inadequate luteal phase is observed in cycles when FSH levels are low or selectively suppressed at any point during the follicular phase.

The mechanism that shuts off the LH surge is unknown. Within hours after the rise in LH, there is a precipitous drop in the plasma estrogens. The decrease in LH may be due to a loss of the positive stimulating action of estradiol or to an increasing negative feedback of progesterone. The abrupt fall in LH levels may also reflect a depletion in pituitary LH content due to down-regulation of GnRH receptors, either by alterations in GnRH pulse frequency or by changes in steroid levels.<sup>266,267</sup> LH may further be controlled by “short” negative feedback of LH upon the hypothalamus. Direct LH suppression of hypothalamic-releasing hormone production has been demonstrated. However, in the sheep, the LH surge ends before the GnRH signal begins to decline.<sup>268</sup> Another possibility has been suggested: a so-called gonadotropin surge-inhibiting factor (GnSIF) originating in the ovary.<sup>269,270</sup> GnSIF is produced in granulosa cells under the control of FSH and reaches a peak level in the circulation in the midfollicular phase. Its major role is believed to be prevention of premature luteinization. It is likely that a combination of all these influences causes the rapid decline in gonadotropin secretion.

The many contributions of progesterone to ovulation are highlighted by the results of

experiments in the monkey. Suppression of steroidogenesis at midcycle prevented ovulation, but not the resumption of oocyte meiosis.<sup>219</sup> Administration of a progestin agonist to this experimental model restored ovulation. In experimental models of mice, knockout of progesterone receptor gene results in failure to ovulate, although oocyte maturation and luteinization are not impeded.<sup>271,272</sup> These experiments indicate that progesterone receptor-A is the critical isoform necessary for normal ovulation.

An adequate gonadotropin surge does not ensure ovulation. The follicle must be at the appropriate stage of maturity for it to respond to the ovulating stimulus. In the normal cycle, gonadotropin release and final maturation of the follicle coincide because the timing of the gonadotropin surge is controlled by the level of estradiol, which in turn is a function of follicular growth and maturation. Therefore, gonadotropin release and morphologic maturity of the follicle are usually coordinated and coupled in time. In the majority of spontaneous cycles in humans, the requisite feedback relationships in this system allow only a single follicle to reach the point of ovulation. Nonidentical multiple births may, in part, reflect the random statistical chance of more than one follicle fulfilling all the requirements for simultaneous ovulation.

## Key Points: Ovulatory Events

- The LH surge initiates the continuation of meiosis in the oocyte, luteinization of the granulosa, and synthesis of progesterone and prostaglandins within the follicle.
- Progesterone enhances the activity of proteolytic enzymes responsible, together with prostaglandins, for digestion and rupture of the follicular wall.
- The progesterone-influenced midcycle rise in FSH serves to free the oocyte from follicular attachments, to convert plasminogen to the proteolytic enzyme, plasmin, and to ensure that sufficient LH receptors are present to allow an adequate normal luteal phase.



# THE LUTEAL PHASE

---

Before rupture of the follicle and release of the ovum, the granulosa cells begin to increase in size and assume a characteristic vacuolated appearance associated with the accumulation of a yellow pigment, lutein, which lends its name to the process of luteinization and the anatomical subunit, the corpus luteum. During the first 3 days after ovulation, the granulosa cells continue to enlarge. In addition, theca lutein cells may differentiate from the surrounding theca and stroma to become part of the corpus luteum. Dissolution of the basal lamina and rapid vascularization and luteinization make it difficult to distinguish the origin of specific cells.

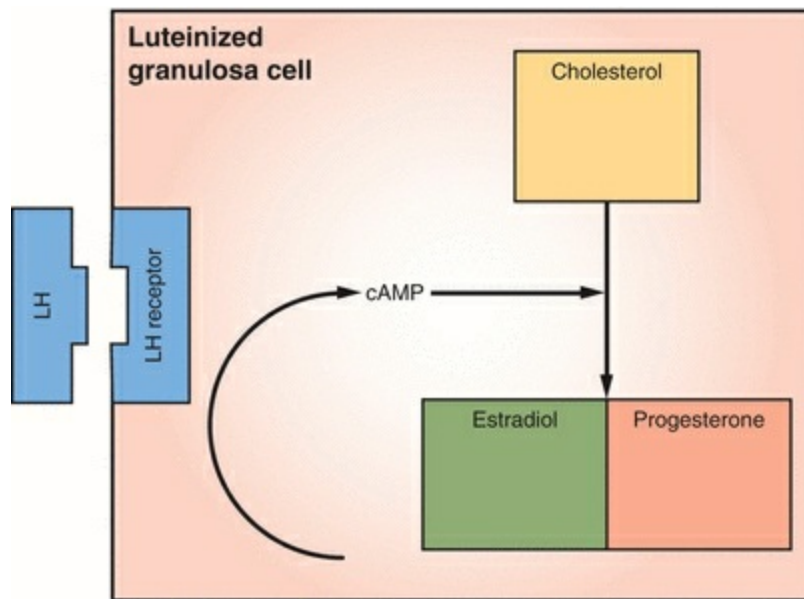
Capillaries begin to penetrate into the granulosa layer after the cessation of the LH surge, reach the central cavity, and often fill it with blood; the corpus luteum at this stage has also been referred to as corpus hemorrhagicum.<sup>273</sup> Angiogenesis is an important feature of the luteinization process, a response to LH that is mediated by factors such as VEGF and angiopoietins produced in luteinized granulosa cells.<sup>174,175,274</sup> In the early luteal phase, angiogenesis accompanies an increased expression of VEGF, with stabilization of vessel growth maintained by angiopoietin-1 binding to the endothelial Tie-2 receptor.<sup>178,275</sup> With regression of the corpus luteum, VEGF and angiopoietin-1 expressions decrease allowing greater occupancy of the Tie-2 receptor by angiopoietin-2, leading to the vascular breakdown that accompanies luteolysis.

By day 8 or 9 after ovulation, a peak of vascularization of the corpus luteum is reached, associated with peak circulating levels of progesterone and estradiol. The corpus luteum has one of the highest blood flows per unit mass in the body. On occasion, this ingrowth of vessels and bleeding will result in unchecked hemorrhage and an acute surgical emergency that can present at any time during the luteal phase. Indeed, excessive bleeding following ovulation can be a real risk for women who are anticoagulated; medical suppression of ovulation, such as through use of a hormonal contraceptive (pill or patch or injection or vaginal ring) should be considered for premenopausal women who are prescribed blood thinners in an effort to minimize the risk of uncontrolled hemorrhage consequent to an otherwise innocuous event of ovulation.

Normal luteal function requires optimal preovulatory follicular development. Suppression of FSH during the follicular phase is associated with lower preovulatory estradiol levels, depressed midluteal progesterone production, and a decrease in luteal cell mass.<sup>276</sup>

Experimental evidence supports the contention that the accumulation of LH receptors during the follicular phase predetermines the extent of luteinization and the subsequent functional capacity of the corpus luteum. Successful conversion of the

avasascular granulosa of follicular phase to the vascularized luteal tissue is also of importance. Because steroid production is dependent upon LDL transport of cholesterol, vascularization of the granulosa layer is essential to allow circulating LDL cholesterol to reach the luteal cells to provide sufficient substrate for progesterone production. One of the important jobs for LH is to regulate LDL receptor binding, internalization, and postreceptor processing; the induction of LDL receptor expression occurs in granulosa cells during the early stages of luteinization in response to the midcycle LH surge.<sup>277,278</sup> This mechanism supplies cholesterol to the mitochondria for utilization as the basic building block in steroidogenesis (**Figure 5.14**).



**FIGURE 5.14**

The life span and steroidogenic capacity of the corpus luteum are dependent on continued tonic LH secretion. Studies in hypophysectomized women have demonstrated that normal corpus luteum function requires the continuous presence of small amounts of LH.<sup>279</sup> This dependence of the corpus luteum on LH is further supported by the prompt luteolysis that follows the administration of GnRH agonists or antagonists or withdrawal of GnRH when ovulation has been induced by the administration of pulsatile GnRH.<sup>280,281</sup> There is no evidence that other luteotropic hormones, such as prolactin, play a role in primates during the menstrual cycle.<sup>282</sup>

The corpus luteum is a complex and heterogeneous structure. Besides the luteal cells, also present are endothelial cells, leukocytes, and fibroblasts. These nonsteroidogenic cells form the bulk, about 70%, of the total cell population of the corpus luteum. The leukocyte population of the corpus luteum contributes several

cytokines, including IL1- $\beta$  and TNF- $\alpha$ .<sup>283</sup> The many different leukocytes in the corpus luteum are also a rich resource for cytolytic enzymes, prostaglandins, and growth factors involved in processes of angiogenesis, steroidogenesis, and luteolysis.

The corpus luteum is one of the best examples of communication and cross talk in biology. For example, endothelial cells contribute vasoactive compounds, and, in turn, steroidogenic cells contribute factors that influence angiogenesis. The harmonious function of this system is in inverse proportion to its complexity.

Endothelial cells constitute about 35% of the cells in a mature corpus luteum.<sup>284</sup> As elsewhere in the body, endothelial cells participate in immune reactions and endocrine functions. The endothelial cells are a source of endothelin-1, expressed in response to changes in blood flow, blood pressure, and oxygen tension. Studies have indicated that endothelin-1 may be a mediator of luteolysis.<sup>285,286</sup> Inhibition of VEGF prevents luteal angiogenesis.<sup>287</sup>

Even the luteal cell population is not homogeneous, being composed of at least two morphologically and functionally distinct cell types, large and small cells.<sup>288</sup> Some believe that the large cells are derived from granulosa cells and the small cells from theca cells. The small cells are the most abundant. Despite the fact that greater steroidogenesis takes place in the large cells, it is the small cells that contain LH and hCG receptors.<sup>289,290</sup> The absence of LH/hCG receptors on the large cells, presumably derived from granulosa cells that acquire LH receptors in the late follicular phase, requires explanation. Perhaps large cells are functioning at a maximal level with receptors totally occupied and functional, or because of intercellular communication through gap junctions, the large cells do not require direct gonadotropin support. Thus, the large cells can be functioning at a high level, under the control of regulating factors that originate in the small cells in response to gonadotropins. In addition, the overall function is influenced by autocrine-paracrine signals from the endothelial and immune cells.

Large luteal cells produce peptides (oxytocin, relaxin, inhibin, GnRH, growth factors, and prostaglandins) and are more active in steroidogenesis, with greater aromatase activity and more progesterone synthesis than the small cells.<sup>291,292</sup> Human granulosa cells (already luteinizing, when recovered from patients undergoing in vitro fertilization) contain minimal amounts of P450c17 mRNA. This is consistent with the two-cell explanation, which assigns androgen production (and P450c17) to the cells derived from theca. With luteinization, expression of StAR, P450scc, and 3- $\beta$  hydroxysteroid dehydrogenase markedly increases to account for the increasing production of progesterone; continued expression of these essential factors requires LH.<sup>293,294,295</sup> The aromatase system (P450arom), of course, continues to be active in the luteinized granulosa cells.

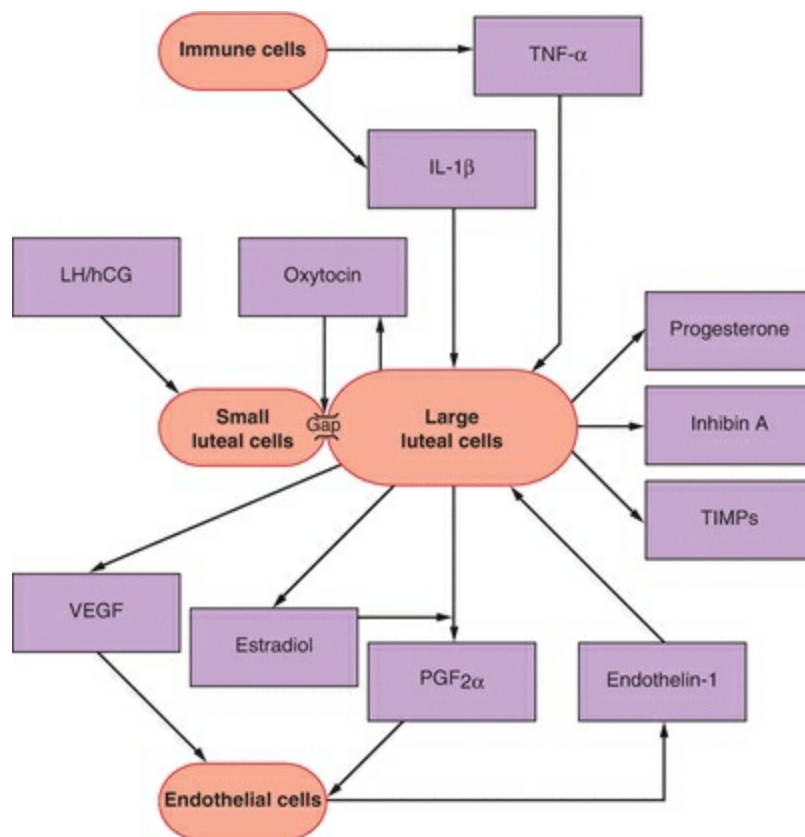
Progesterone levels normally rise sharply after ovulation, reaching a peak approximately 8 days after the LH surge. Initiation of new follicular growth during the luteal phase is further inhibited by the low levels of gonadotropins due to the negative feedback actions of estrogen, progesterone, and inhibin A. With the appearance of LH receptors on the granulosa cells of the dominant follicle and the subsequent transformation of the ovulatory follicle into a corpus luteum, inhibin expression comes under the control of LH, and expression changes from inhibin B to inhibin A.<sup>126,289,296</sup> The circulating levels of inhibin A rise in the late follicular phase to reach a peak level at the midluteal phase.<sup>33,127,188</sup> Inhibin A, therefore, contributes to the suppression of FSH to nadir levels during the luteal phase, and to the changes at the luteal-follicular transition. There is a wave of small follicle growth during the luteal phase, probably in response to the FSH surge at midcycle; however, the luteal phase FSH suppression ensures that a mature, large follicle will not emerge.<sup>297,298</sup>

The secretion of progesterone and estradiol during the luteal phase is episodic, and the changes correlate closely with LH pulses.<sup>100,299</sup> Because of this episodic secretion, relatively low midluteal progesterone levels, which some inappropriately believe are indicative of an inadequate luteal phase, can be found in the course of totally normal luteal phases. The corpus luteum of the primate is unique in its production of estrogen; however, unlike the follicular phase, luteal estrogen synthesis is dependent on LH. Within the corpus luteum, progesterone acts locally to enhance the LH-induced luteinization of granulosa cells, to support its own LH-stimulated synthesis, and to inhibit apoptosis.<sup>300,301,302</sup>

In the normal cycle, the time period from the LH midcycle surge to menses is consistently close to 14 days. For practical purposes, luteal phases lasting between 11 and 17 days can be considered normal.<sup>303</sup> The incidence of short luteal phases is about 5–6%. It is well known that significant variability in cycle length among women is due to the varying number of days required for follicular growth and maturation in the follicular phase. The luteal phase cannot be extended indefinitely even with progressively increasing LH exposure, indicating that the demise of the corpus luteum is due to an active luteolytic mechanism.

The corpus luteum rapidly declines 9–11 days after ovulation, and the mechanism of the degeneration remains unknown. In certain nonprimate mammalian species, a luteolytic factor originating in the uterus and stimulated by estrogen (prostaglandin  $F_{2\alpha}$ ) regulates the life span of the corpus luteum. No definite luteolytic factor has been identified in the primate menstrual cycle, and removal of the uterus in the primate does not affect the ovarian cycle. The morphologic regression of luteal cells may be induced by the estradiol produced by the corpus luteum.<sup>304</sup> A premature elevation of circulating

estradiol levels in the early luteal phase results in a prompt fall in progesterone concentrations, and direct injections of estradiol into the ovary bearing the corpus luteum induce luteolysis, while similar treatment of the contralateral ovary produces no effect.<sup>305</sup> This action of estrogen may be mediated by nitric oxide. Nitric oxide stimulates luteal prostaglandin synthesis and decreases progesterone production.<sup>306</sup> Nitric oxide and hCG have opposing actions in the human corpus luteum; nitric oxide is associated with apoptosis of luteal cells.<sup>307</sup> The final signal for luteolysis, however, is prostaglandin  $F_{2\alpha}$  that is produced within the ovary in response to the locally synthesized luteal estrogen (**Figure 5.15**).<sup>305,308</sup> These relationships are supported by genome studies delineating prostaglandin  $F_{2\alpha}$  and hCG effects on gene expression.<sup>309</sup> The early luteal phase in primates is dominated by intraluteal synthesis of the luteotropic prostaglandin,  $PGE_2$ ; late in the luteal phase, intraluteal prostaglandin synthesis shifts to  $PGF_{2\alpha}$ .<sup>292</sup>



**FIGURE 5.15**

There is another possible role for the estrogen produced by the corpus luteum. In view of the known estrogen requirement for the synthesis of progesterone receptors in the

endometrium, luteal phase estrogen may be necessary to allow the progesterone-induced changes in the endometrium after ovulation. Inadequate progesterone receptor content due to inadequate estrogen priming of the endometrium is an additional possible mechanism for subfertility; similarly, some early miscarriages (biochemical losses) may represent a form of luteal phase deficiency.

Experimental evidence indicates that the luteolytic effect of prostaglandin  $F_{2\alpha}$  is partially mediated by endothelin-1.<sup>285,286</sup> Prostaglandin  $F_{2\alpha}$  stimulates the synthesis of endothelin-1; endothelin-1 inhibits luteal steroidogenesis, and in turn, endothelin-1 stimulates prostaglandin production in luteal cells.<sup>310</sup> In addition, endothelin-1 stimulates the release of TNF- $\alpha$ , a growth factor known to induce apoptosis; members of the TNF family, including their receptors, are expressed in the corpus luteum and their expression peaks at the time of luteolysis.<sup>311,312</sup>

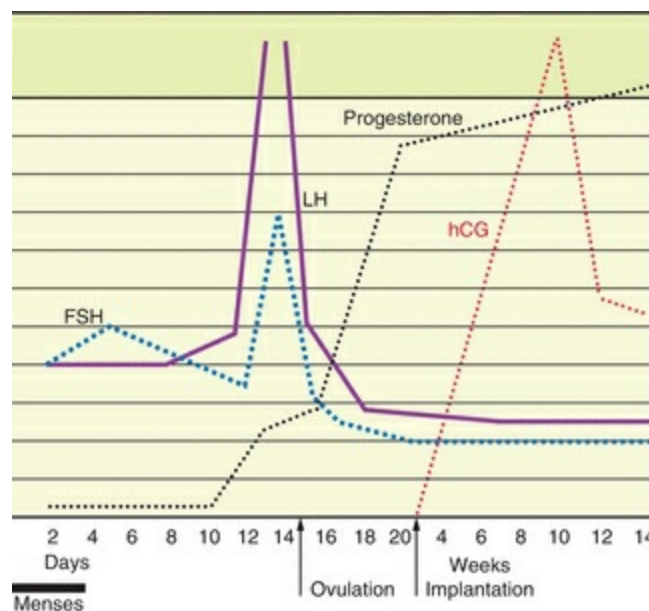
The corpus luteum involves cellular interactions that require cell-to-cell contact. Gap junctions are a prominent feature of luteal cells, just as they are in the follicle before ovulation. When the various cell types of the corpus luteum are studied together, the performance is different compared with studies of single-cell types, greater steroidogenesis more closely approximating the total function of the corpus luteum.<sup>313</sup> It is believed that communication and exchange of signals takes place through the gap junction structures, explaining how the small cells respond to LH and hCG, but the large cells are the main site of steroidogenesis. Regulation of the gap junction system is influenced by oxytocin, a paracrine role for oxytocin in the corpus luteum.<sup>25</sup>

When ovulation is induced by the administration of GnRH, normal luteal phase demise occurs despite no change in treatment, arguing against a change in LH as the dominant luteolytic mechanism. In addition, LH receptor-binding affinity does not change throughout the luteal phase. Thus, the decline in steroidogenesis must reflect deactivation of the system (producing a refractoriness of the corpus luteum to LH), perhaps through the uncoupling of the G protein adenylate cyclase system. This is supported by studies in the monkey in which alteration in LH pulse frequency or amplitude did not provoke luteolysis.<sup>314</sup>

The process of luteolysis involves proteolytic enzymes, especially the MMPs. These enzymes are held under inhibitory control by TIMPs secreted by the steroidogenic luteal cells, and because TIMP levels do not change in luteal tissue, luteolysis is believed to involve a direct increase in MMP expression. An important part of the rescue mission for hCG is to prevent this increase in MMP expression.<sup>315</sup> hCG can increase TIMP production, and this, too, would inhibit MMP activity and luteolysis.<sup>316</sup> The source of MMPs is the fibroblast cell, and because luteal fibroblasts do not contain LH/hCG receptors, the release of MMPs in the regressing corpus luteum

must depend on another signal. One such signal can be locally produced activin-A that acts upon the fibroblasts to synthesize and release MMPs.<sup>317</sup> Emerging hCG from a pregnancy can inhibit this activin-A system by increasing follistatin, the glycopeptide that binds the activin. In addition, human ovary contains the complete IL-1 system, providing another source of cytolytic enzymes.

The survival of the corpus luteum is prolonged by the emergence of a new stimulus of rapidly increasing intensity, the hCG. Blastocysts grown in culture produce and secrete hCG, beginning days 7–8 after fertilization.<sup>318</sup> Messenger RNA for hCG can be found in 6- to 8-cell human embryos.<sup>319</sup> Because the 8- to 12-cell stage is achieved about 3 days after fertilization, it is believed that the human embryo begins to produce hCG before implantation when it can be detected in the mother as early as 6–7 days after ovulation. The embryo is capable, therefore, of preimplantation signaling, and higher levels of estradiol and progesterone can be measured in the maternal circulation even before maternal hCG is detectable, presumably because of stimulation of the corpus luteum by hCG delivered directly from the uterine cavity to the ovary (**Figure 5.16**).<sup>320</sup> Function of the corpus luteum is crucial during the first 7–9 weeks of pregnancy, and luteectomy early in pregnancy can precipitate miscarriage.<sup>321</sup> Similarly, early pregnancy loss in primates can be induced by injections of anti-hCG serum.<sup>322</sup> Rescue of the corpus luteum by rising hCG levels from an early pregnancy is associated with maintenance of the corpus luteal vascular system (not new vessel growth), a process that is dependent on the angiogenic factors VEGF and angiopoietin-2.<sup>177,178,275,323</sup>



**FIGURE 5.16**

Unlike the biphasic luteal pattern of circulating progesterone levels (a decrease after ovulation and then a new higher peak at the midluteal phase), mRNA levels for the two major enzymes involved in progesterone synthesis (cholesterol side-chain cleavage and 3 $\beta$ -hydroxysteroid dehydrogenase) are maximal at ovulation and decline throughout the luteal phase.<sup>323</sup> This suggests that the life span of the corpus luteum is established at the time of ovulation, and luteal regression is inevitable unless the corpus luteum is rescued by the hCG of pregnancy. **Therefore, primates have developed a system that requires rescue of the corpus luteum in contrast to lower animals that use a mechanism that actively causes the demise of the corpus luteum (luteolysis).**

## Key Points: Luteal Phase

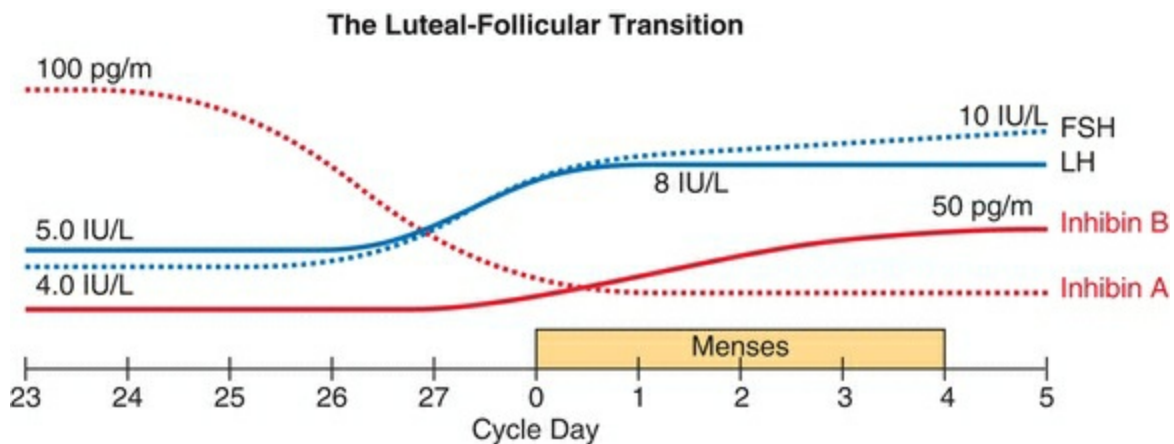
- Normal luteal function requires optimal preovulatory follicular development (especially adequate FSH stimulation) and continued tonic LH support.
- The early luteal phase is marked by active angiogenesis mediated by VEGF. New vessel growth is held in check by angiopoietin-1 working through its receptor Tie-2 on endothelial cells.
- Progesterone, estradiol, and inhibin A act centrally to suppress gonadotropins and new follicular growth during the luteal phase.
- Regression of the corpus luteum is associated with a decrease in VEGF and angiopoietin-1 expression and an increase in angiopoietin-2 activity and may involve the luteolytic action of its own estrogen production, mediated by an alteration in local prostaglandin and involving nitric oxide, endothelin, and other factors.
- In early pregnancy, hCG rescues the corpus luteum, maintaining luteal function until placental steroidogenesis is well established.



# THE LUTEAL-FOLLICULAR TRANSITION

The interval extending from the late luteal decline of estradiol and progesterone production to the selection of the dominant follicle for the ensuing cycle is a critical and decisive time, marked by the appearance of menses; equally important but less apparent are the hormone changes that initiate the next cycle. The critical factors include GnRH, FSH, LH, estradiol, progesterone, and inhibin.

Given the important role for FSH-mediated actions on the granulosa cells, it is appropriate that the recruitment of a new ovulating follicle is directed by a selective increase in FSH that begins approximately 2 days before the onset of menses (**Figure 5.17**).<sup>324,325,326,327</sup> Using a sensitive FSH bioassay, an increase in FSH bioactivity can be measured beginning as early as the midluteal phase.<sup>34</sup> There are at least two influential changes that result in this important increase in FSH: a decrease in the luteal steroids and inhibin and a change in GnRH pulsatile secretion.



**FIGURE 5.17**

Inhibin B, originating in the granulosa cells of the corpus luteum and now under the regulation of LH, reaches a nadir in the circulation at the midluteal period.<sup>188</sup> Inhibin A reaches a peak in the luteal phase, and, thus, may help to suppress FSH secretion by the pituitary to the lowest levels reached during a menstrual cycle.<sup>33,188</sup> The process of luteolysis, whatever the mechanism/s, with resulting demise of the corpus luteum, affects inhibin-A secretion as well as steroidogenesis. Administration of inhibin A to monkeys effectively suppresses circulating FSH.<sup>328</sup> Thus, an important suppressing influence on FSH secretion is removed from the anterior pituitary during the last days of the luteal phase. This selective action of inhibin on FSH (and not LH) is partly responsible for the greater rise in FSH seen during the luteal-follicular transition,

compared to the change in LH. Administration of recombinant (pure) FSH to gonadotropin-deficient women has demonstrated that the early growth of follicles requires FSH, and that LH is not essential during this period of the cycle.<sup>61,62</sup>

Inhibin-B levels begin to rise shortly after the increase in FSH (a consequence of FSH stimulation of granulosa cell secretion of inhibin) and reach peak levels about 4 days after the maximal increase in FSH.<sup>33,118,188</sup> Thus, suppression of FSH secretion during the follicular phase is an action exerted by inhibin B, whereas escape of FSH inhibition during the luteal-follicular transition is partly a response to decreasing inhibin A secretion by the regressing corpus luteum.

Circulating levels of activin increase before ovulation to a peak in the luteal phase; however, activin A is highly bound in the circulation, and it is not certain if it has an endocrine role.<sup>148,188</sup> Nevertheless, the timing is right for activin to contribute to the rise in FSH during the luteal-follicular transition. Activin enhances and follistatin suppresses GnRH activity. Evidence in vivo and in vitro indicates that gonadotropin response to GnRH requires activin activity.<sup>329</sup> Activin specifically acts synergistically with GnRH to stimulate gene expression in the pituitary for the FSH beta-subunit.<sup>330</sup>

The selective rise in FSH is also significantly influenced by a change in GnRH pulsatile secretion, previously strongly suppressed by the high estradiol and progesterone levels of the luteal phase exerting a negative feedback effect at the hypothalamus.<sup>104,331</sup> A progressive and rapid increase in GnRH pulses (as assessed by the measurement of LH pulses) occurs during the luteal-follicular transition.<sup>103</sup> From the midluteal peak to menses, there is a 4.5-fold increase in LH pulse frequency (and presumably GnRH) from approximately 3 pulses/24 hours to 14 pulses/24 hours.<sup>103</sup> During this time period, the mean level of LH increases approximately 2-fold, from approximately a mean of 4.8–8 IU/L. The increase in FSH is, as noted, greater than that of LH. FSH pulse frequency increases 3.5-fold from the midluteal period to the time of menses, and FSH levels increase from a mean of approximately 4 IU/L to as much as 15 IU/L.

An increase in GnRH pulse frequency has been associated with an initial selective increase in FSH in several experimental models, including the ovariectomized monkey with destruction of the hypothalamus. Treatment of hypogonadal women with pulsatile GnRH results first in predominance of FSH secretion (over LH). This experimental response and the changes during the luteal-follicular transition are similar to changes observed during puberty with a predominance of FSH as GnRH pulsatile secretion begins to increase.

The pituitary response to GnRH is also relevant in the luteal follicular transition period. Estradiol suppresses FSH secretion by its classic negative feedback

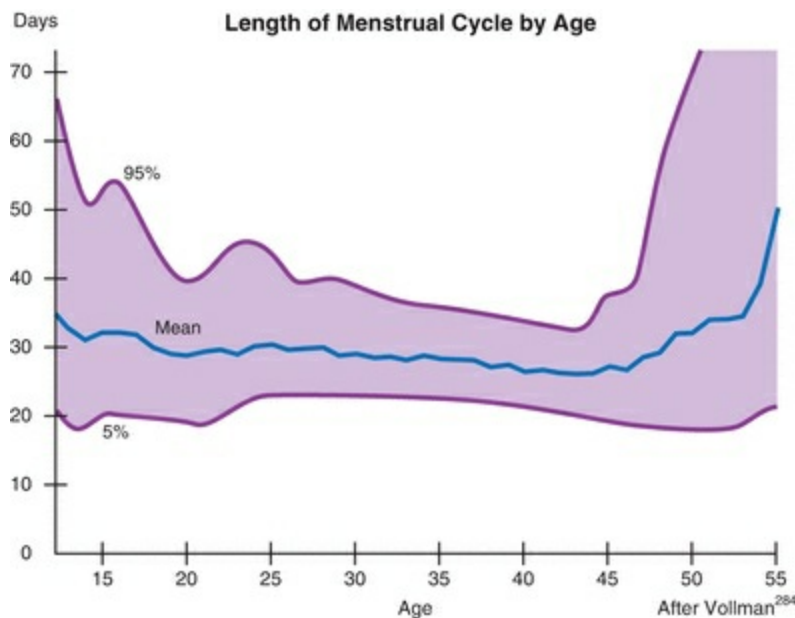
relationship at the pituitary level. The decrease in estradiol in the late luteal phase restores the capability of the pituitary to respond with an increase in FSH secretion.<sup>332</sup>

## Key Points: Luteal-Follicular Transition

- The demise of the corpus luteum results in a nadir in the circulating levels of estradiol, progesterone, and inhibin.
- The decrease in inhibin A removes a suppressing influence on FSH secretion in the pituitary.
- The decrease in estradiol and progesterone allows a progressive and rapid increase in the frequency of GnRH pulsatile secretion and removal of the pituitary from negative feedback suppression.
- The removal of inhibin A and estradiol and increasing GnRH pulses combine to allow greater secretion of FSH compared with LH, with an increase in the frequency of the episodic secretion.
- The rising FSH is instrumental in rescuing approximately a 70-day-old group of ready follicles from atresia, initiating a new wave of follicular recruitment, growth that is destined for attainment of dominance of a single follicle in the ensuing cycle.

# THE NORMAL MENSTRUAL CYCLE

Menstrual cycle length (duration between day 1 of menses to the 1st day of subsequent menses) is determined by the rate and the quality of follicular growth and development, and it is normal for the cycle length to vary in individual women.<sup>333,334</sup> Subtle alterations in cycle length are appreciated with advancing age, and cycle lengths are the shortest (with the least variability) in the late 30s, a time when subtle but real increases in FSH and decreases in inhibin are occurring (**Figure 5.18**).<sup>124,303,335,336,337,338</sup> This can be pictured as accelerated follicular growth (because of the changes in FSH and inhibin B). At the same time, fewer follicles grow per cycle as a woman ages.<sup>339</sup> Approximately 2–4 years prior to the final menstrual period (marking the end of reproductive phase and the onset of menopause), the cycles lengthen again. In the last 10–15 years before menopause, there is an acceleration of follicular loss.<sup>3</sup> This accelerated loss begins when the total number of follicles reaches approximately 25,000, a number reached in normal women at age 37–38. Eventually menopause occurs because the supply of follicles is near depleted.<sup>340</sup>



**FIGURE 5.18**

The changes in the later reproductive years reflect either lesser follicular competence as the better primordial follicles respond early in life, leaving the lesser follicles for later, or the fact that the total follicular pool is reduced in number (or both factors).<sup>341</sup> Arguing in favor of a role for a reduced follicular pool is the observation that follicular fluid obtained from preovulatory follicles of older women contains amounts of inhibins

A and B that are similar to that measured in follicular fluid from young women.<sup>342</sup>

Variations in menstrual flow and cycle length are common at the extremes of reproductive age, during the early teenage years and in the years preceding the menopause. The prevalence of anovulatory cycles is highest in women under age 20 and over age 40.<sup>343,344</sup> Menarche is typically followed by approximately 5–7 years of relatively long cycles that gradually decrease in length and become more regular. Although menstrual cycle characteristics generally do not change appreciably during the reproductive years,<sup>344</sup> overall cycle length and variability slowly decrease. On average, mean cycle length and variability reach their lows at about age 40–42.<sup>334,345</sup> Over the subsequent 8–10 years before the menopause, the trend is reversed; both average cycle length and variability steadily increase as ovulations become less regular and more infrequent.<sup>333,334,346,347</sup> Mean cycle length is greater in women at the extremes of body mass and composition; both high and low body mass index are associated with an increased mean cycle length.<sup>348,349</sup>

In general, variations in cycle length reflect differences in the length of the follicular phase of the ovarian cycle. Women who have a 25-day cycle ovulate on or about cycle day 10–12, and those with a 35-day cycle ovulate approximately 10 days later. Within a few years after menarche, the luteal phase becomes extremely consistent (13–15 days) and remains so until the perimenopause.<sup>332,333</sup> At age 25, over 40% of cycles are between 25 and 28 days in length; from age 25 to 35, over 60% are. Although it is the most often reported intermenstrual interval, only approximately 15% of cycles in reproductive-aged women are actually 28 days in length. Less than 1% of women have a regular cycle lasting less than 21 days or more than 35 days.<sup>350</sup> Most women have cycles that last from 24 to 35 days, but at least 20% of women experience irregular cycles.<sup>345</sup>

# REFERENCES

1. **Baker TG**, A quantitative and cytological study of germ cells in human ovaries, *Proc R Soc Lond B Biol Sci* 158:417, 1963.
2. **Peters H, Byskov AG, Himmelstein-Graw R, Faber M**, Follicular growth: the basic event in the mouse and human ovary, *J Reprod Fertil* 45:559, 1975.
3. **Gougeon A, Echiohard R, Thalabard JC**, Age-related changes of the population of human ovarian follicles: increase in the disappearance rate of non-growing and early-growing follicles in aging women, *Biol Reprod* 50:653, 1994.
4. **Mais V, Kazer RR, Cetel NS, Rivier J, Vale W, Yen SS**, The dependency of folliculogenesis and corpus luteum function on pulsatile gonadotropin secretion in cycling women using a gonadotropin-releasing hormone antagonist as a probe, *J Clin Endocrinol Metab* 62:1250, 1986.
5. **Gougeon A**, Dynamics of follicular growth in the human: a model from preliminary results, *Hum Reprod* 1:81, 1986.
6. **Gougeon A**, Regulation of ovarian follicular development in primates: facts and hypotheses, *Endocr Rev* 17:121, 1996.
7. **Oktay K, Newton H, Mullan J, Gosden RG**, Development of human primordial follicles to antral stages in SCID/hpg mice stimulated with follicle stimulating hormone, *Hum Reprod* 13:1133, 1998.
8. **Schipper I, Hop WC, Fauser BC**, The follicle-stimulating hormone (FSH) threshold/window concept examined by different interventions with exogenous FSH during the follicular phase of the normal menstrual cycle: duration, rather than magnitude, of FSH increase affects follicle development, *J Clin Endocrinol Metab* 83:1292, 1998.
9. **Hsueh AJ, Eisenhauer K, Chun SY, Hsu SY, Billig H**, Gonadal cell apoptosis, *Recent Prog Horm Res* 51:433, 1996.
10. **Trombly DJ, Woodruff TK, Mayo KE**, Roles for transforming growth factor beta superfamily proteins in early folliculogenesis, *Semin Reprod Med* 27:14, 2009.
11. **Dissen GA, Garcia-Rudaz C, Ojeda SR**, Role of neurotrophic factors in early ovarian development, *Semin Reprod Med* 27:24, 2009.
12. **Gittens JE, Kidder GM**, Differential contributions of connexin37 and connexin43 to oogenesis revealed in chimeric reaggregated mouse ovaries, *J Cell Sci* 118:5071, 2005.
13. **Su YQ, Sugiura K, Eppig JJ**, Mouse oocyte control of granulosa cell development and function: paracrine regulation of cumulus cell metabolism, *Semin Reprod Med* 27:32, 2009.
14. **Juengel JL, McNatty KP**, The role of proteins of the transforming growth factor-beta superfamily in the intraovarian regulation of follicular development, *Hum Reprod Update* 11:143, 2005.
15. **Dong J, Albertini DF, Nishimori K, Kumar TR, Lu N, Matzuk MM**, Growth differentiation factor-9 is required during early ovarian folliculogenesis, *Nature* 383:531, 1996.
16. **Erickson GF, Shimasaki S**, The role of the oocyte in folliculogenesis, *Trends Endocrinol Metab* 11:193, 2000.
17. **Kovanci E, Rohozinski J, Simpson JL, Heard MJ, Bishop CE, Carson SA**, Growth differentiating factor-9 mutations may be associated with premature ovarian failure, *Fertil Steril* 87:143, 2007.
18. **Zhang P, Shi YH, Wang LC, Chen ZJ**, Sequence variants in exons of the BMP-15 gene in Chinese patients with premature ovarian failure, *Acta Obstet Gynecol Scand* 86:585, 2007.
19. **Uhlenhaut NH, Treier M**, Fox12 function in ovarian development, *Mol Genet Metab* 88:225, 2006.
20. **Moumné L, Baatista F, Benayoun BA, Nallathambi J, Fellous M, Sundaresan P, Veitia RA**, The mutations and potential targets of the fork head transcription factor FOXL2, *Mol Cell Endocrinol* 282:2, 2008.
21. **Schmidt D, Ovitt CE, Anlag K, Fehsenfeld S, Gredsted L, Treier AC, Treier M**, The murine winged-helix transcription factor Foxl2 is required for granulosa cell differentiation and ovary maintenance, *Development* 131:933, 2004.
22. **Ackert CL, Gittens JE, O'Brien MJ, Eppig JJ, Kidder GM**, Intercellular communication via connexin43 gap junctions is required for ovarian folliculogenesis in the mouse, *Dev Biol* 233:258, 2001.

23. **Granot I, Dekel N**, Developmental expression and regulation of the gap junction protein and transcription in rat ovaries, *Mol Reprod Dev* 47:231, 1997.
24. **Granot I, Dekel N**, The ovarian gap junction protein connexin43: regulation by gonadotropins, *Trends Endocrinol Metab* 13:310, 2002.
25. **Khan-Dawood FS**, Oxytocin in intercellular communication in the corpus luteum, *Semin Reprod Endocrinol* 15:395, 1998.
26. **Halpin DMG, Jones A, Fink G, Charlton HM**, Postnatal ovarian follicle development in hypogonadal (hpg) and normal mice and associated changes in the hypothalamic-pituitary axis, *J Reprod Fertil* 77:287, 1986.
27. **Baker TC, Scrimgeour JB**, Development of the gonad in normal and anencephalic human fetuses, *J Reprod Fertil* 60:193, 1980.
28. **Oktay K, Briggs DA, Gosden RG**, Ontogeny of follicle-stimulating hormone receptor gene expression in isolated human ovarian follicles, *J Clin Endocrinol Metab* 82:3748, 1997.
29. **Barnes RB, Namnoum AB, Rosenfield RL, Layman LC**, The role of LH and FSH in ovarian androgen secretion and ovarian follicular development: clinical studies in a patient with isolated FSH deficiency and multicystic ovaries, *Hum Reprod* 17:88, 2002.
30. **Matthews CH, Borgato S, Beck-Peccoz P, Adams M, Tone Y, Gambino G, Casagrande S, Tedeschini G, Benedetti A, Chatterjee VK**, Primary amenorrhoea and infertility due to a mutation in the b-subunit of follicle-stimulating hormone, *Nat Genet* 5:83, 1993.
31. **Pache TD, Wladimiroff JW, de Jong FH, Hop WC, Fauser BC**, Growth patterns of non dominant ovarian follicles during the normal menstrual cycle, *Fertil Steril* 54:638, 1990.
32. **Vermesh M, Kletzky OA**, Longitudinal evaluation of the luteal phase and its transition into the follicular phase, *J Clin Endocrinol Metab* 65:653, 1987.
33. **Welt CK, Martin KM, Taylor AE, Lambert-Messerlian GM, Crowley WF Jr, Smith JA, Schoenfeld DA, Hall JE**, Frequency modulation of follicle-stimulating hormone (FSH) during the luteal-follicular transition: evidence for FSH control of inhibin B in normal women, *J Clin Endocrinol Metab* 82:2645, 1997.
34. **Christin-Maitre S, Taylor AE, Houry RH, Hall JE, Martin KA, Smith PC, Albanese C, Jameson JL, Crowley WF Jr, Sluss PM**, Homologous in vitro bioassay for follicle-stimulating hormone (FSH) reveals increased FSH biological signal during the mid- to late luteal phase of the human menstrual cycle, *J Clin Endocrinol Metab* 81:2080, 1996.
35. **Van Deerlin PG, Cekleniak N, Coutifaris C, Boyd J, Strauss JF III**, Evidence for the oligoclonal origin of the granulosa cell population of the mature human follicle, *J Clin Endocrinol Metab* 82:3019, 1997.
36. **Yong EL, Baird DT, Hillier SG**, Mediation of gonadotropin-stimulated growth and differentiation of human granulosa cells by adenosine-3', 5'-monophosphate: one molecule, two messages, *Clin Endocrinol* 37:51, 1992.
37. **McNatty KP, Makris A, DeGrazia C, Osathanondh R, Ryan KJ**, The production of progesterone, androgens, and estrogens by granulosa cells, thecal tissue, and stromal tissue from human ovaries in vitro, *J Clin Endocrinol Metab* 49:687, 1979.
38. **LaPolt PS, Tilly JL, Aihara T, Nishimori K, Hsueh AJ**, Gonadotropin-induced up- and down-regulation of ovarian follicle-stimulating hormone (FSH) receptor gene expression in immature rats: effects of pregnant mare's serum gonadotropin, human chorionic gonadotropin, and recombinant FSH, *Endocrinology* 130:1289, 1992.
39. **Tilly JL, LaPolt PS, Hsueh AJ**, Hormonal regulation of follicle-stimulating hormone receptor messenger ribonucleic acid levels in cultured rat granulosa cells, *Endocrinology* 130:1296, 1992.
40. **Erickson GF**, An analysis of follicle development and ovum maturation, *Semin Reprod Endocrinol* 4:233, 1986.
41. **Fletcher WH, Greenan JRT**, Receptor mediated action without receptor occupancy, *Endocrinology* 116:1660, 1985.
42. **Hild-Petito S, West NB, Brenner RM, Stouffer RL**, Localization of androgen receptor in the follicle and corpus luteum of the primate ovary during the menstrual cycle, *Biol Reprod* 44:561, 1991.
43. **McNatty KP, Makris A, Reinhold VN, DeGrazia C, Osathanondh R, Ryan KJ**, Metabolism of androstenedione by human ovarian tissues in vitro with particular reference to reductase and aromatase activity, *Steroids* 34:429, 1979.

44. **Hillier SG, Van Den Boogard AMJ, Reichert LE, Van Hall EV**, Intraovarian sex steroid hormone interactions and the regulation of follicular maturation: aromatization of androgens by human granulosa cells in vitro, *J Clin Endocrinol Metab* 50:640, 1980.
45. **Jia X-C, Kessel B, Welsh TH Jr, Hsueh AJW**, Androgen inhibition of follicle-stimulating hormone-stimulated luteinizing hormone receptor formation in cultured rat granulosa cells, *Endocrinology* 117:13, 1985.
46. **Erickson GF, Magoffin DA, Dyer CA, Hofeditz C**, The ovarian androgen producing cells: a review of structure/function relationships, *Endocr Rev* 6:371, 1985.
47. **Chabab A, Hedon B, Arnal F, Diafouka F, Bressot N, Flandre O, Cristol P**, Follicular steroids in relation to oocyte development and human ovarian stimulation protocols, *Hum Reprod* 1:449, 1986.
48. **Greisen S, Ledet T, Ovesen P**, Effects of androstenedione, insulin and luteinizing hormone on steroidogenesis in human granulosa luteal cells, *Hum Reprod* 16:2061, 2001.
49. **Eppig JJ, Chesnel F, Hirao Y, O'Brien MJ, Pendola FL, Watanabe S, Wigglesworth K**, Oocyte control of granulosa cell development: how and why, *Hum Reprod* 12(Suppl):127, 1997.
50. **McNatty KP, Smith DM, Makris A, Osathanondh R, Ryan KJ**, The microenvironment of the human antral follicle; inter-relationships among the steroid levels in antral fluid, the population of granulosa cells, and the status of the oocyte in vivo and in vitro, *J Clin Endocrinol Metab* 49:851, 1979.
51. **McNatty KP, Markris A, DeGrazia C, Osathanondh R, Ryan KJ**, Steroidogenesis by recombined follicular cells from the human ovary in vitro, *J Clin Endocrinol Metab* 51:1286, 1980.
52. **Andersen CY**, Characteristics of human follicular fluid associated with successful conception after in vitro fertilization, *J Clin Endocrinol Metab* 77:1227, 1993.
53. **McNatty KP, Smith DM, Makris A, DeGrazia C, Tulchinsky D, Osathanondh R, Schiff I, Ryan KJ**, The intraovarian sites of androgen and estrogen formation in women with normal and hyperandrogenic ovaries as judged by in vitro experiments, *J Clin Endocrinol Metab* 50:755, 1980.
54. **Hillier SG**, Paracrine control of follicular estrogen synthesis, *Semin Reprod Endocrinol* 9:332, 1991.
55. **Kobayashi M, Nakano R, Ooshima A**, Immunohistochemical localization of pituitary gonadotropins and gonadal steroids confirms the two cells two gonadotropins hypothesis of steroidogenesis in the human ovary, *J Endocrinol* 126:483, 1990.
56. **Yamoto M, Shima K, Nakano R**, Gonadotropin receptors in human ovarian follicles and corpora lutea throughout the menstrual cycle, *Horm Res* 37(Suppl 1): 5, 1992.
57. **Magoffin DA**, Regulation of differentiated functions in ovarian theca cells, *Semin Reprod Endocrinol* 9:321, 1991.
58. **Azhar S, Tsai L, Medicherla S, Chandrasekher Y, Giudice L, Reaven E**, Human granulosa cells use high density lipoprotein cholesterol for steroidogenesis, *J Clin Endocrinol Metab* 83:983, 1998.
59. **Sasano H, Okamoto M, Mason JI, Simpson ER, Mendelson CR, Sasano N, Silverberg SG**, Immunolocalization of aromatase, 17 $\alpha$ -hydroxylase and side-chain-cleavage cytochromes P-450 in the human ovary, *J Reprod Fertil* 85:163, 1989.
60. **Sasano H**, Functional pathology of human ovarian steroidogenesis: normal cycling ovary and steroid-producing neoplasms, *Endocr Pathol* 5:81, 1994.
61. **Schoot DC, Coelingh-Bennink HJT, Mannaerts BMJL, Lamberts SW, Bouchard P, Fauser BC**, Human recombinant follicle-stimulating hormone induces growth of preovulatory follicles without concomitant increase in androgen and estrogen biosynthesis in a woman with isolated gonadotropin deficiency, *J Clin Endocrinol Metab* 74:1471, 1992.
62. **Shoham Z, Mannaerts B, Insler V, Coelingh-Bennink H**, Induction of follicular growth using recombinant human follicle-stimulating hormone in two volunteer women with hypogonadotropic hypogonadism, *Fertil Steril* 59:738, 1993.
63. **Ben-Chetrit A, Gotlieb L, Wong PY, Casper RF**, Ovarian response to recombinant human follicle-stimulating hormone in luteinizing hormone-depleted women: examination of the two cell, two gonadotropin theory, *Fertil Steril* 65:711, 1996.
64. **Karnitis VJ, Townson DH, Friedman CI, Danforth DR**, Recombinant human follicle-stimulating hormone stimulates multiple follicular growth, but minimal estrogen production in gonadotropin-releasing hormone



- antagonist-treated monkeys: examining the role of luteinizing hormone in follicular development and steroidogenesis, *J Clin Endocrinol Metab* 79:91, 1994.
65. **Zelinski-Wooten MB, Hutchison JS, Hess DL, Wolf DP, Stouffer RL**, Follicle stimulating hormone alone supports follicle growth and oocyte development in gonadotropin-releasing hormone antagonist-treated monkeys, *Hum Reprod* 10:1658, 1995.
  66. **The European Recombinant Human LH Study Group**, Recombinant human luteinizing hormone (LH) to support recombinant human follicle-stimulating hormone (FSH)-induced follicular development in LH- and FSH-deficient anovulatory women: a dose-finding study, *J Clin Endocrinol Metab* 83:1507, 1998.
  67. **Goodman AL, Hodgen GD**, The ovarian triad of the primate menstrual cycle, *Recent Prog Horm Res* 39:1, 1983.
  68. **Tilly JL, Kowalski KI, Schomberg DW, Hsueh AJ**, Apoptosis in atretic ovarian follicles is associated with selected decreases in messenger ribonucleic acid transcripts for gonadotropin receptors and cytochrome P450 aromatase, *Endocrinology* 131:1670, 1992.
  69. **Montgomery Rice V, Limback SD, Roby KF, Terranova PF**, Differential responses of granulosa cells from small and large follicles to follicle stimulating hormone (FSH) during the menstrual cycle and acyclicity: effects of tumour necrosis factor- $\alpha$ , *Hum Reprod* 13:1285, 1998.
  70. **Durlinger AL, Grujters MJ, Kramer P, Karels B, Ingraham HA, Nachtigal MW, Uilenbroek JT, Grootegoed JA, Themmen AP**, Anti-Müllerian hormone inhibits initiation of primordial follicle growth in the mouse ovary, *Endocrinology* 143:1076, 2002.
  71. **Salmon NA, Handyside AH, Joyce IM**, Oocyte regulation of anti-Müllerian hormone expression in granulosa cells during ovarian follicle development in mice, *Dev Biol* 266:201, 2004.
  72. **Andersen CY, Byskov AG**, Estradiol and regulation of anti-Müllerian hormone, inhibin-A, and inhibin-B secretion: analysis of small antral and preovulatory human follicles' fluid, *J Clin Endocrinol Metab* 91:4064, 2006.
  73. **Durlinger AL, Visser JA, Themmen AP**, Regulation of ovarian function: the role of anti-Müllerian hormone, *Reproduction* 124:601, 2002.
  74. **van Rooij IA, Baroekmans FJ, Scheffer GJ, Looman CW, Habbema JD, De Jong FH, Fauser BJ, Themmen AP, te Velde ER**, Serum antimüllerian hormone levels best reflect the reproductive decline with age in normal women with proven fertility: a longitudinal study, *Fertil Steril* 83:979, 2005.
  75. **Streuli I, Fraisse T, Pillet C, Ibecheole V, Bischof P, de Ziegler D**, Serum antimüllerian hormone levels remain stable throughout the menstrual cycle and after oral or vaginal administration of synthetic sex steroids, *Fertil Steril* 90:395, 2008.
  76. **Bentzen JG, Forman JL, Pinborg A, Lidegaard Ø, Larsen EC, Friis-Hansen L, Johannsen TH, Nyboe Andersen A**, Ovarian reserve parameters: a comparison between users and non-users of hormonal contraception, *Reprod Biomed Online* 25(6):612, 2012.
  77. **Chikasawa K, Araki S, Tameda T**, Morphological and endocrinological studies on follicular development during the human menstrual cycle, *J Clin Endocrinol Metab* 62:305, 1986.
  78. **Clark JR, Dierschke DJ, Wolf RC**, Hormonal regulation of ovarian folliculogenesis in rhesus monkeys. III. Atresia of the preovulatory follicle induced by exogenous steroids and subsequent follicular development, *Biol Reprod* 25:3320, 1981.
  79. **Zeleznik AJ, Schuler HM, Reichert LE**, Gonadotropin-binding sites in the rhesus monkey ovary: role of the vasculature in the selective distribution of human chorionic gonadotropin to the preovulatory follicle, *Endocrinology* 109:356, 1981.
  80. **Ravindranath N, Little-Ihrig L, Phillips HS, Ferrara N, Zeleznik AJ**, Vascular endothelial growth factor messenger ribonucleic acid expression in the primate ovary, *Endocrinology* 131:254, 1992.
  81. **Suzuki T, Sasano H, Takaya R, Fukaya T, Yajima A, Nagura H**, Cyclic changes of vasculature and vascular phenotypes in normal human ovaries, *Hum Reprod* 13:953, 1998.
  82. **Richards JS, Jahnsen T, Hedin L, Lifka J, Ratoosh SL, Durica JM, Goldring NB**, Ovarian follicular development: from physiology to molecular biology, *Recent Prog Horm Res* 43:231, 1987.
  83. **Jia X-C, Hsueh AJW**, Homologous regulation of hormone receptors: luteinizing hormone increases its own

- receptors in cultured rat granulosa cells, *Endocrinology* 115:2433, 1984.
84. **Kessel B, Liu YX, Jia X-C, Hsueh AJ**, Autocrine role of estrogens in the augmentation of luteinizing hormone receptor formation in cultured rat granulosa cells, *Biol Reprod* 32:1038, 1985.
  85. **Filicori M, Cognigni GE, Tabarelli C, Pocognoli P, Taraborrelli S, Spettoli D, Ciampaglia W**, Stimulation and growth of antral ovarian follicles by selective LH activity administration in women, *J Clin Endocrinol Metab* 87:1156, 2002.
  86. **Filicori M, Cognigni GE, Ciampaglia W**, Effects of LH on oocyte yield and developmental competence, *Hum Reprod* 18:1357, 2003.
  87. **Young KA, Chaffin CL, Molskness TA, Stouffer RL**, Controlled ovulation of the dominant follicle: a critical role for LH in the late follicular phase of the menstrual cycle, *Hum Reprod* 18:2257, 2003.
  88. **Hild-Petito S, Stouffer RL, Brenner RM**, Immunocytochemical localization of estradiol and progesterone receptors in the monkey ovary throughout the menstrual cycle, *Endocrinology* 123:2896, 1988.
  89. **Enmark E, Peltö-Huikko M, Grandien K, Lagercrantz S, Lagercrantz J, Fried G, Nordenskjöld M, Gustafsson J-Å**, Human estrogen receptor  $\beta$ -gene structure, chromosomal localization, and expression pattern, *J Clin Endocrinol Metab* 82:4258, 1997.
  90. **Duffy DM, Chaffin CL, Stouffer RL**, Expression of estrogen receptor alpha and beta in the rhesus monkey corpus luteum during the menstrual cycle: regulation by luteinizing hormone and progesterone, *Endocrinology* 141:1711, 2000.
  91. **Hosokawa K, Ottander U, Wahlberg P, Ny T, Cajander S, Olofsson IJ**, Dominant expression and distribution of oestrogen receptor beta over oestrogen receptor alpha in the human corpus luteum, *Mol Hum Reprod* 7:137, 2001.
  92. **Bocca SM, Billiar RB, Albrecht ED, Pepe GJ**, Oocytes of baboon fetal primordial ovarian follicles express estrogen receptor  $\beta$  mRNA, *Endocrine* 33:254, 2008.
  93. **Xia L, Van Vugt D, Alston EJ, Luckhaus J, Ferin M**, A surge of gonadotropin-releasing hormone accompanies the estradiol-induced gonadotropin surge in the Rhesus monkey, *Endocrinology* 131:2812, 1992.
  94. **Hall JE, Taylor AE, Martin KA, Rivier J, Schoenfeld DA, Crowley WF Jr**, Decreased release of gonadotropin-releasing hormone during the preovulatory midcycle luteinizing hormone surge in normal women, *Proc Natl Acad Sci* 91:6894, 1994.
  95. **Ottowitz WE, Dougherty DD, Fischman AJ, Hall JE**, (18F)2-fluoro-2-deoxy-D-glucose positron emission tomography demonstration of estrogen negative and positive feedback on luteinizing hormone secretion in women, *J Clin Endocrinol Metab* 93:3208, 2008.
  96. **Chappel SC, Resko JA, Norman RL, Spies HG**, Studies on rhesus monkeys on the site where estrogen inhibits gonadotropins: delivery of  $17\beta$ -estradiol to the hypothalamus and pituitary gland, *J Clin Endocrinol Metab* 52:1, 1981.
  97. **Wildt L, Hutchison JS, Marshall G, Pohl CR, Knobil E**, On the site of action of progesterone in the blockade of the estradiol-induced gonadotropin discharge in the rhesus monkey, *Endocrinology* 109:1293, 1981.
  98. **Young JR, Jaffe RB**, Strength-duration characteristics of estrogen effects on gonadotropin response to gonadotropin-releasing hormone in women. II. Effects of varying concentrations of estradiol, *J Clin Endocrinol Metab* 42:432, 1976.
  99. **Cahill DJ, Wardle PG, Harlow CR, Hull MG**, Onset of the preovulatory luteinizing hormone surge: diurnal timing and critical follicular prerequisites, *Fertil Steril* 70:56, 1998.
  100. **Filicori M, Santoro N, Merriam GR, Crowley WF Jr**, Characterization of the physiological pattern of episodic gonadotropin secretion throughout the human menstrual cycle, *J Clin Endocrinol Metab* 62:1136, 1986.
  101. **Rossmannith WG, Laughlin GA, Mortola JF, Johnson ML, Veldhuis JD, Yen SS**, Pulsatile cosecretion of estradiol and progesterone by the midluteal phase corpus luteum: temporal link to luteinizing hormone pulses, *J Clin Endocrinol Metab* 70:990, 1990.
  102. **Evans WS, Sollenberger MJ, Booth RA Jr, Rogol AD, Urban RJ, Carlsen EC, Johnson ML, Veldhuis JD**, Contemporary aspects of discrete peak-detection algorithms. II. The paradigm of the luteinizing hormone pulse signal in women, *Endocr Rev* 13:81, 1992.
  103. **Hall JE, Schoenfeld DA, Martin KA, Crowley WF Jr**, Hypothalamic gonadotropin-releasing hormone

- secretion and follicle-stimulating hormone dynamics during the luteal-follicular transition, *J Clin Endocrinol Metab* 74:600, 1992.
104. **Nippold TB, Reame NE, Kelch RP, Marshall JC**, The roles of estradiol and progesterone in decreasing luteinizing hormone pulse frequency in the luteal phase of the menstrual cycle, *J Clin Endocrinol Metab* 69:67, 1989.
  105. **Marunic M, Casper RF**, The effect of luteal phase estrogen antagonism on luteinizing hormone pulsatility and luteal function in women, *J Clin Endocrinol Metab* 64:148, 1987.
  106. **Laatikainen T, Raisanen I, Tulenheimo A, Salminen K**, Plasma  $\beta$ -endorphin and the menstrual cycle, *Fertil Steril* 44:206, 1985.
  107. **Wehrenberg WB, Wardlaw SL, Frantz AG, Ferin M**,  $\beta$ -Endorphin in hypophyseal portal blood: variations throughout the menstrual cycle, *Endocrinology* 111:879, 1982.
  108. **Urban RJ, Veldhuis JD, Dufau ML**, Estrogen regulates the gonadotropin-releasing hormone-stimulated secretion of biologically active luteinizing hormone, *J Clin Endocrinol Metab* 72:660, 1991.
  109. **Zambrano E, Olivares A, Mendez JP, Guerrero L, Díaz-Cueto L, Veldhuis JD, Ulloa-Aguirre A**, Dynamics of basal and gonadotropin-releasing hormone-releasable serum follicle-stimulating hormone charge isoform distribution throughout the human menstrual cycle, *J Clin Endocrinol Metab* 80: 1647, 1995.
  110. **Zariñán T, Olivares A, Söderlund D, Méndez JP, Ulloa-Aguirre A**, Changes in the biological:immunological ratio of basal and GnRH-releasable FSH during the follicular, pre-ovulatory and luteal phases of the human menstrual cycle, *Hum Reprod* 16:1611, 2001.
  111. **Mortola JF, Laughlin GA, Yen SSC**, A circadian rhythm of serum follicle-stimulating hormone in women, *J Clin Endocrinol Metab* 75:861, 1992.
  112. **Rivier C, Rivier J, Vale W**, Inhibin-mediated feedback control of follicle-stimulating hormone secretion in the female rat, *Science* 234:205, 1986.
  113. **Bicsak TA, Tucker EM, Cappel S, Vaughan J, Rivier J, Vale W, Hsueh AJ**, Hormonal regulation of granulosa cell inhibin biosynthesis, *Endocrinology* 119:2711, 1986.
  114. **Xiao S, Robertson DM, Findlay JK**, Effects of activin and follicle-stimulating hormone (FSH)-suppressing protein/follistatin on FSH receptors and differentiation of cultured rat granulosa cells, *Endocrinology* 131:1009, 1992.
  115. **Matzuk MM, Finegold MJ, Su J-GJ, Hsueh AJ, Bradley A**, Alpha-inhibin is a tumour-suppressor gene with gonadal specificity in mice, *Nature* 360:313, 1992.
  116. **McLachlan RI, Robertson DM, Healy DL, Burger HG, De Kretser DM**, Circulating immunoreactive inhibin levels during the normal human menstrual cycle, *J Clin Endocrinol Metab* 65:954, 1987.
  117. **Buckler HM, Healy DL, Burger HG**, Purified FSH stimulates inhibin production from the human ovary, *J Endocrinol* 122:279, 1989.
  118. **Groome NP, Illingworth PG, O'Brien M, Pai R, Rodger FE, Mather JP, McNeilly AS**, Measurement of dimeric inhibin B throughout the human menstrual cycle, *J Clin Endocrinol Metab* 81:1401, 1996.
  119. **Lockwood GM, Muttukrishna S, Ledger WL**, Inhibins and activins in human ovulation, conception and pregnancy, *Hum Reprod Update* 4:284, 1998.
  120. **Kang SK, Tai CJ, Nathwani PS, Leung PCK**, Differential hormonal regulation of two forms of GnRH mRNA in cultured human granulosa luteal cells, *Endocrinology* 142:182, 2001.
  121. **Khosravi S, Leung PC**, Differential regulation of gonadotropin-releasing hormone (GnRH)I and GnRHII messenger ribonucleic acid by gonadal steroids in human granulosa luteal cells, *J Clin Endocrinol Metab* 88:663, 2003.
  122. **Klein NA, Illingworth PJ, Groome NP, McNeilly AS, Battaglia DE, Soules MR**, Decreased inhibin B secretion is associated with the monotropic FSH rise in older, ovulatory women: a study of serum and follicular fluid levels of dimeric inhibin A and B in spontaneous menstrual cycles, *J Clin Endocrinol Metab* 81:2742, 1996.
  123. **Lockwood GM, Muttukrishna S, Groome NP, Matthews DR, Ledger WL**, Mid-follicular phase pulses of inhibin B are absent in polycystic ovarian syndrome and are initiated by successful laparoscopic ovarian diathermy: a possible mechanism regulating emergence of the dominant follicle, *J Clin Endocrinol Metab* 83:1730, 1998.

124. **Hofmann GE, Danforth DR, Seifer DB**, Inhibin-B: the physiologic basis of the clomiphene citrate challenge test for ovarian reserve screening, *Fertil Steril* 69:474, 1998.
125. **Meyer AC, Papadimitriou JC, Silverberg SG, Sharara FI**, Secondary amenorrhea and infertility caused by an inhibin-B-producing ovarian fibrothecoma, *Fertil Steril* 73:258, 2000.
126. **McLachlin RI, Cohen NL, Vale WE, Rivier JE, Burger HG, Bremmer WJ, Soules MR**, The importance of luteinizing hormone in the control of inhibin and progesterone secretion by the human corpus luteum, *J Clin Endocrinol Metab* 68:1078, 1989.
127. **Schipper I, de Jong FH, Fauser BCJM**, Lack of correlation between maximum early follicular phase serum follicle stimulating hormone concentrations and menstrual cycle characteristics in women under the age of 35 years, *Hum Reprod* 13:1442, 1998.
128. **Fang J, Yin W, Smiley E, Wang SQ, Bonadio J**, Genes coding for mouse activin  $\beta$ C and  $\beta$ E are closely linked and exhibit a liver-specific expression pattern in adult tissues, *Biochem Biophys Res Commun* 231:655, 1997.
129. **Lau AL, Kumar TR, Nishimori K, Bonadio J, Matzuk MM**, Activin  $\beta$ C and  $\beta$ E genes are not essential for mouse liver growth, differentiation, and regeneration, *Mol Cell Biol* 20:6127, 2000.
130. **Kitaoka M, Kojima I, Ogata E**, Activin-A: a modulator of multiple types of anterior pituitary cells, *Biochem Biophys Res Commun* 157:48, 1988.
131. **Billestrup N, Gonzalez-Manchon C, Potter E, Vale W**, Inhibition of somatotroph growth and growth hormone biosynthesis by activin in vitro, *Mol Endocrinol* 4:356, 1990.
132. **Corrigan AZ, Bilezikjian LM, Carroll RS, Bald LN, Schmelzer CH, Fendly BM, Mason AJ, Chin WW, Schwall RH, Vale W**, Evidence for an autocrine role of activin B within rat anterior pituitary cultures, *Endocrinology* 128:1682, 1991.
133. **Blumenfeld Z**, Response of human fetal pituitary cells to activin, inhibin, hypophysiotropic and neuroregulatory factors in vitro, *Early Pregnancy* 5:41, 2001.
134. **Kaiser UB, Conn PM, Chin WW**, Studies of gonadotropin-releasing hormone (GnRH) action using GnRH receptor-expressing pituitary cell lines, *Endocr Rev* 18:46, 1997.
135. **Norwitz ER, Xu S, Jeong KH, Bedecarrats GY, Winebrenner LD, Chin WW, Kaiser UB**, Activin A augments GnRH-mediated transcriptional activation of the mouse GnRH receptor gene, *Endocrinology* 143:985, 2002.
136. **Bilezikjian LM, Corrigan AZ, Blount AL, Vale WW**, Pituitary follistatin and inhibin subunit messenger ribonucleic acid levels are differentially regulated by local and hormonal factors, *Endocrinology* 137:4277, 1996.
137. **Mason AJ, Hayflick JS, Ling N, Esch F, Ueno N, Ying SY, Guillemin R, Niall H, Seeburg PH**, Complementary DNA sequences of ovarian follicular fluid inhibin show precursor structure and homology with transforming growth factor- $\beta$ , *Nature* 318:659, 1985.
138. **Hillier SG, Yong EL, Illingworth PJ, Baird DT, Schwall RH, Mason AJ**, Effect of recombinant inhibin on androgen synthesis in cultured human thecal cells, *Mol Cell Endocrinol* 75:R1, 1991.
139. **Hillier SG, Yong EL, Illingworth PJ, Baird DT, Schwall RH, Mason AJ**, Effect of recombinant activin on androgen synthesis in cultured human thecal cells, *J Clin Endocrinol Metab* 72:1206, 1991.
140. **Sawetawan C, Carr BR, McGee E, Bird IM, Hong TL, Rainey WE**, Inhibin and activin differentially regulate androgen production and  $17\alpha$ -hydroxylase expression in human ovarian thecal-like cells, *J Endocrinol* 148:213, 1996.
141. **Attisano L, Wrana JL, Cheifetz S, Massague J**, Novel activin receptors: distinct genes and alternative mRNA splicing generate a repertoire of serine/threonine kinase receptors, *Cell* 68:97, 1992.
142. **Alak BM, Smith GD, Woodruff TK, Stouffer RL, Wolf DP**, Enhancement of primate oocyte maturation and fertilization in vitro by inhibin A and activin A, *Fertil Steril* 66:646, 1996.
143. **Braden TD, Conn PM**, Activin-A stimulates the synthesis of gonadotropin-releasing hormone receptors, *Endocrinology* 130:2101, 1992.
144. **Kaiser UB, Lee BL, Carroll RS, Unabia G, Chin WW, Childs GV**, Follistatin gene expression in the pituitary: localization in gonadotrophs and folliculostellate cells in diestrous rats, *Endocrinology* 130:3048, 1992.
145. **Kogawa K, Nakamura T, Sugiono K, Takio K, Titani K, Sugino H**, Activin-binding protein is present in

pituitary, *Endocrinology* 128:1434, 1991.

146. **Besecke LM, Guendner MJ, Sluss PA, Polak AG, Woodruff TK, Jameson JL, Bauer-Dantoin AC, Weiss J**, Pituitary follistatin regulates activin-mediated production of follicle-stimulating hormone during the rat estrous cycle, *Endocrinology* 138:2841, 1997.
147. **Robertson DM**, Follistatin/activin-binding protein, *Trends Endocrinol Metab* 3:65, 1992.
148. **Muttukrishna S, Fowler PA, George L, Groome NP, Knight PG**, Changes in peripheral serum levels of total activin A during the human menstrual cycle and pregnancy, *J Clin Endocrinol Metab* 81:3328, 1996.
149. **Giudice LC**, Insulin-like growth factors and ovarian follicular development, *Endocr Rev* 13:641, 1992.
150. **Shimasaki S, Ling N**, Identification and molecular characterization of insulin-like growth factor binding proteins (IGFBP-1, -2, -3, -4, -5, and -6), *Prog Growth Factor Res* 3:243, 1992.
151. **El-Roeiy A, Chen X, Roberts VJ, LeRoith D, Roberts CT Jr, Yen SSC**, Expression of insulin-like growth factor-I (IGF-I) and IGF-II and the IGF-I, IGF-II, and insulin receptor genes and localization of the gene products in the human ovary, *J Clin Endocrinol Metab* 77:1411, 1993.
152. **Voutilainen R, Franks S, Mason HD, Martikainen H**, Expression of insulin-like growth factor (IGF), IGF-binding protein, and IGF receptor messenger ribonucleic acids in normal and polycystic ovaries, *J Clin Endocrinol Metab* 81:1003, 1996.
153. **Hernandez ER, Hurwitz A, Vera A, Pellicer A, Adashi EY, LeRoith D, Roberts CT Jr**, Expression of the genes encoding the insulin-like growth factors and their receptors in the human ovary, *J Clin Endocrinol Metab* 74:419, 1992.
154. **Mason HD, Cwyfan-Hughes SC, Heinrich G, Franks S, Holly JMP**, Insulin-like growth factor (IGF) I and II, IGF-binding proteins, and IGF-binding protein proteases are produced by theca and stroma of normal and polycystic human ovaries, *J Clin Endocrinol Metab* 81:276, 1996.
155. **Bergh C, Carlsson B, Olsson J-H, Selleskog U, Hillensjo T**, Regulation of androgen production in cultured human thecal cells by insulin-like growth factor I and insulin, *Fertil Steril* 59:323, 1993.
156. **Nahum R, Thong KJ, Hillier SG**, Metabolic regulation of androgen production by human thecal cells in vitro, *Hum Reprod* 10:75, 1995.
157. **Mason HD, Willis DS, Holly JMP, Franks S**, Insulin preincubation enhances insulin-like growth factor-II (IGF-II) action on steroidogenesis in human granulosa cells, *J Clin Endocrinol Metab* 78:1265, 1994.
158. **DiBlasio AM, Viganó P, Ferrari A**, Insulin-like growth factor-II stimulates human granulosa-luteal cell proliferation in vitro, *Fertil Steril* 61:483, 1994.
159. **Barreca A, Artini PG, Del Monte P, Ponzani P, Pasquini P, Cariola G, Volpe A, Genazzani AR, Giordano G, Minuto F**, In vivo and in vitro effect of growth hormone on estradiol secretion by human granulosa cells, *J Clin Endocrinol Metab* 77:61, 1993.
160. **Thierry van Dessel HJ, Chandrasekher YA, Yap OW, Lee PD, Hintz RL, Faessen GH, Braat DD, Fauser BC, Giudice LC**, Serum and follicular fluid levels of insulin-like growth factor (IGF)-I, IGF-II, and IGF binding proteins-1 and -3 during the normal menstrual cycle, *J Clin Endocrinol Metab* 81: 1224, 1995.
161. **Thierry van Dessel HJ, Chandrasekher Y, Yap OW, Lee PD, Hintz RL, Faessen GH, Braat DD, Fauser BC, Giudice LC**, Serum and follicular fluid levels of insulin-like growth factor I (IGF-I), IGF-II, and IGF-binding protein-1 and -3 during the normal menstrual cycle, *J Clin Endocrinol Metab* 81:1224, 1996.
162. **Grimes RW, Samaras SE, Barber JA, Shimasaki S, Ling N, Hammond JM**, Gonadotropin and cyclic-AMP modulation of insulin-like growth factor-binding protein production in ovarian granulosa cells, *Am J Physiol* 262: E497, 1992.
163. **Dor J, Costritsci N, Pariente C, Rabinovici J, Mashiach S, Lunenfeld B, Kaneti H, Seppala M, Roistinen R, Karasik A**, Insulin-like growth factor-I and follicle-stimulating hormone suppress insulin-like growth factor binding protein-1 secretion by human granulosa-luteal cells, *J Clin Endocrinol Metab* 75:969, 1992.
164. **San Roman GA, Magoffin DA**, Insulin-like growth factor-binding proteins in healthy and atretic follicles during natural menstrual cycles, *J Clin Endocrinol Metab* 76:625, 1992.
165. **Amato G, Izzo A, Tucker A, Bellastella A**, Insulin-like growth factor binding protein-3 reduction in follicular fluid in spontaneous and stimulated cycles, *Fertil Steril* 70:141, 1998.

166. **Cataldo NA, Giudice LC**, Follicular fluid insulin-like growth factor binding protein profiles in polycystic ovary syndrome, *J Clin Endocrinol Metab* 74: 695, 1992.
167. **Cataldo NA, Giudice LC**, Insulin-like growth factor binding protein profiles in human ovarian follicular fluid correlate with follicular functional status, *J Clin Endocrinol Metab* 74:821, 1992.
168. **Chandrasekher YA, van Dessel HJ, Fauser BCJM, Giudice LC**, Estrogen- but not androgen-dominant human ovarian follicular fluid contains an insulin-like growth factor binding protein-4 protease, *J Clin Endocrinol Metab* 80:2734, 1995.
169. **Dor J, Ben-Shlomo I, Lunenfeld B, Pariente C, Levran D, Karasik A, Seppala M, Mashiach S**, Insulin-like growth factor-I (IGF-I) may not be essential for ovarian follicular development: evidence from IGF-I deficiency, *J Clin Endocrinol Metab* 74:539, 1992.
170. **Ben-Ami I, Armon L, Freimann S, Strassburger D, Ron-El R, Amsterdam A**, EGF-like growth factors as LH mediators in the human corpus luteum, *Hum Reprod* 24:176, 2009.
171. **Dodson WC, Schomberg DW**, The effect of transforming growth factor- on follicle-stimulating hormone-induced differentiation of cultured rat granulosa cells, *Endocrinology* 120:512, 1987.
172. **Hernandez ER, Hurwitz A, Payne DW, Dharmarajan AM, Purchio AF, Adashi EY**, Transforming growth factor-beta 1 inhibits ovarian androgen production: gene expression, cellular localization, mechanisms(s), and site(s) of action, *Endocrinology* 127:2804, 1990.
173. **Oury F, Faucher C, Rives I, Bensaid M, Bouche G, Darbon J-M**, Regulation of cyclic adenosine 3',5'-monophosphate-dependent protein kinase activity and regulatory subunit RIIB content by basic fibroblast growth factor (bFGF) during granulosa cell differentiation: possible implication of protein kinase C in bFGF action, *Biol Reprod* 47:202, 1992.
174. **Christenson LK, Stouffer RL**, Follicle-stimulating hormone and luteinizing hormone/chorionic gonadotropin stimulation of vascular endothelial factor production by macaque granulosa cells from pre- and periovulatory follicles, *J Clin Endocrinol Metab* 82:2135, 1997.
175. **Anasti JN, Kalantaridou SN, Kimzey LM, George M, Nelson LM**, Human follicle fluid vascular endothelial growth factor concentrations are correlated with luteinization in spontaneously developing follicles, *Hum Reprod* 13:1144, 1998.
176. **Lee A, Christenson LK, Patton PE, Burry KA, Stouffer RL**, Vascular endothelial growth factor production by human luteinized granulosa cells in vitro, *Hum Reprod* 12:2756, 1997.
177. **Wulff C, Dickson SE, Duncan WC, Fraser HM**, Angiogenesis in the human corpus luteum: simulated early pregnancy by HCG treatment is associated with both angiogenesis and vessel stabilization, *Hum Reprod* 16:2515, 2001.
178. **Fraser HM, Wilson H, Wulff C, Rudge JS, Wiegand SJ**, Administration of vascular endothelial growth factor trap in the 'post angiogenic' period of the luteal phase causes rapid functional luteolysis and endothelial death in the marmoset, *Reproduction* 132:589, 2006.
179. **Taylor PD, Wilson H, Hillier SG, Wiegand SJ, Fraser HM**, Effects of inhibition of vascular endothelial growth factor at time of selection on follicular angiogenesis, expansion, development and atresia in the marmoset, *Mol Hum Reprod* 13:729, 2007.
180. **Xu F, Hazzard TM, Evans A, Charnock-Jones S, Smith S, Stouffer RL**, Intraovarian actions of anti-angiogenic agents disrupt periovulatory events during the menstrual cycle in monkeys, *Contraception* 71:239, 2005.
181. **Kokia E, Hurwitz A, Ricciarelli E, Tedeschi C, Resnick CE, Mitchell MD, Adashi EY**, Interleukin-1 stimulates ovarian prostaglandin biosynthesis: evidence for heterologous contact-independent cell-cell interaction, *Endocrinology* 130:3095, 1992.
182. **Itskovitz J, Sealey JE**, Ovarian prorenin-renin-angiotensin system, *Obstet Gynecol Surv* 42:545, 1987.
183. **Petraglia F, Di Meo G, Storchi R, Segre A, Facchinetti F, Szalay S, Volpe A, Genazzani AR**, Proopiomelanocortin-related peptides and methionine enkephalin in human follicular fluid: changes during the menstrual cycle, *Am J Obstet Gynecol* 157:142, 1987.
184. **Asakura H, Zwain IH, Yen SS**, Expression of genes encoding corticotropin-releasing factor (CRF), type 1 CRF receptor, and CRF-binding protein and localization of the gene products in the human ovary, *J Clin*

Endocrinol Metab 82:2720, 1997.

185. **Erden HF, Zwain IH, Asakura H, Yen SS**, Corticotropin-releasing factor inhibits luteinizing hormone-stimulated P450c17 gene expression and androgen production by isolated thecal cells of human ovarian follicles, *J Clin Endocrinol Metab* 83:448, 1998.
186. **Kim JH, Seibel MM, MacLaughlin DT, Donahoe PK, Ransil BJ, Hametz PA, Richards CJ**, The inhibitory effects of müllerian-inhibiting substance on epidermal growth factor induced proliferation and progesterone production of human granulosa-luteal cells, *J Clin Endocrinol Metab* 75:911, 1992.
187. **Seifer DB, MacLaughlin DT, Penzias AS, Behrman HR, Asmundson L, Donahoe PK, Haning RV Jr, Flynn SD**, Gonadotropin-releasing hormone agonist-induced differences in granulosa cell cycle kinetics are associated with alterations in follicular fluid Müllerian-inhibiting substance and androgen content, *J Clin Endocrinol Metab* 76:711, 1993.
188. **Wunder DM, Bersinger NA, Yared M, Kretschmer R, Birkhäuser MH**, Statistically significant changes of antimüllerian hormone and inhibin levels during the physiologic menstrual cycle in reproductive age women, *Fertil Steril* 89:927, 2008.
189. **Weenen C, Laven JSE, Von Bergh AR, Cranfield M, Groome NP, Visser JA, Kramer P, Fauser BC, Themmen AP**, Anti-Müllerian hormone expression pattern in the human ovary: potential implications for initial and cyclic follicle recruitment, *Mol Hum Reprod* 10:77, 2004.
190. **Fanchin R, Louafi N, Méndez Lozano DH, Frydman N, Frydman R, Taieb J**, Per-follicle measurements indicate that anti-müllerian hormone secretion is modulated by the extent of follicular development and luteinization and may reflect qualitatively the ovarian follicular status, *Fertil Steril* 84:167, 2005.
191. **Tedeschi C, Hazum E, Kokia E, Ricciarelli E, Adashi EY, Payne DW**, Endothelin-1 as a luteinization inhibitor: inhibition of rat granulosa cell progesterone accumulation via selective modulation of key steroidogenic steps affecting both progesterone formation and degradation, *Endocrinology* 131:2476, 1992.
192. **Zelinski-Wooten MB, Hess DL, Baughman WL, Molskness TA, Wolf DP, Stouffer RL**, Administration of an aromatase inhibitor during the late follicular phase of gonadotropin-treated cycles in Rhesus monkeys: effects on follicle development, oocyte maturational, and subsequent luteal function, *J Clin Endocrinol Metab* 76:988, 1993.
193. **Zelinski-Wooten MB, Hess DL, Wolf DP, Stouffer RL**, Steroid reduction during ovarian stimulation impairs oocyte fertilization, but not folliculogenesis, in rhesus monkeys, *Fertil Steril* 61:1147, 1994.
194. **Shetty G, Krishnamurthy H, Krishnamurthy HN, Bhatnagar AS, Moudgal NR**, Effect of estrogen deprivation on the reproductive physiology of male and female primates, *J Steroid Biochem Mol Biol* 61:157, 1997.
195. **Rabinovici J, Blankstein J, Goldman B, Rudak E, Dor Y, Pariente C, Geier A, Lunenfeld B, Mashiach S**, In vitro fertilization and primary embryonic cleavage are possible in 17-hydroxylase deficiency despite extremely low intrafollicular 17 $\beta$ -estradiol, *J Clin Endocrinol Metab* 68:693, 1989.
196. **Pellicer A, Miro F, Sampaio M, Gomez E, Bonilla-Maroles FM**, In vitro fertilization as a diagnostic and therapeutic tool in a patient with partial 17,20-desmolase deficiency, *Fertil Steril* 55:970, 1991.
197. **Miro F, Hillier SG**, Relative effects of activin and inhibin on steroid hormone synthesis in primate granulosa cells, *J Clin Endocrinol Metab* 75:1556, 1992.
198. **Rabinovici J, Spencer SJ, Doldi N, Goldsmith PC, Schwall R, Jaffe RB**, Activin-A as an intraovarian modulator: actions, localization and regulation of the intact dimer in human ovarian cells, *J Clin Invest* 89:1528, 1992.
199. **Hillier SG, Wickings EJ, Illingworth PI, Yong EL, Reichert LE Jr, Baird DT, McNeilly AS**, Control of immunoactive inhibin production by human granulosa cells, *Clin Endocrinol* 35:71, 1991.
200. **Brannian JD, Stouffer RL, Molskness TA, Chandrasekher YA, Sarkissian A, Dahl KD**, Inhibin production by Macaque granulosa cells from pre- and periovulatory follicles: regulation by gonadotropins and prostaglandin E2, *Biol Reprod* 46:451, 1992.
201. **Marrs RP, Lobo R, Campeau JD, Nakamura RM, Brown J, Ujita EL, diZerega GS**, Correlation of human follicular fluid inhibin activity with spontaneous and induced follicle maturation, *J Clin Endocrinol Metab* 58:704, 1984.

202. **Schwall RH, Mason AJ, Wilcox JN, Bassett SG, Zeleznik AJ**, Localization of inhibin/activin subunit mRNAs within the primate ovary, *Mol Endocrinol* 4:75, 1990.
203. **Sugawara M, DePaolo L, Nakatani A, DiMarzo S, Ling N**, Radioimmunoassay of follistatin: application for in vitro fertilization procedures, *J Clin Endocrinol Metab* 71:1672, 1990.
204. **Welt CK, Smith ZA, Pauler DK, Hall JE**, Differential regulation of inhibin A and inhibin B by luteinizing hormone, follicle-stimulating hormone, and stage of follicle development, *J Clin Endocrinol Metab* 86:2531, 2001.
205. **Magoffin DA, Jakimiuk AJ**, Inhibin A, inhibin B and activin A in the follicular fluid of regularly cycling women, *Hum Reprod* 12:1714, 1997.
206. **Schneyer AL, Fujiwara T, Fox J, Welt CK, Adams J, Messerlian GM, Taylor AE**, Dynamic changes in the intrafollicular inhibin/activin/follistatin axis during human follicular development: relationship to circulating hormone concentrations, *J Clin Endocrinol Metab* 85:3319, 2000.
207. **Fujiwara T, Sidis Y, Welt C, Lambert-Messerlian G, Fox J, Taylor A, Schneyer A**, Dynamics of inhibin subunit and follistatin mRNA during development of normal and polycystic ovary syndrome follicles, *J Clin Endocrinol Metab* 86:4206, 2001.
208. **Welt CK, Schneyer AL**, Differential regulation of inhibin B and inhibin A by follicle-stimulating hormone and local growth factors in human granulosa cells from small antral follicles, *J Clin Endocrinol Metab* 86:330, 2001.
209. **O'Dea L, O'Brien F, Currie K, Hemsey G**, Follicular development induced by recombinant luteinizing hormone (LH) and follicle-stimulating hormone (FSH) in anovulatory women with LH and FSH deficiency: evidence of a threshold effect, *Curr Med Res Opin* 24:2785, 2008.
210. **Pauerstein CJ, Eddy CA, Croxatto HD, Hess R, Siler-Khodr TM, Croxatto HB**, Temporal relationships of estrogen, progesterone, and luteinizing hormone levels to ovulation in women and infrahuman primates, *Am J Obstet Gynecol* 130:876, 1978.
211. **Fritz MA, McLachlan RI, Cohen NL, Dahl KD, Bremner WJ, Soules MR**, Onset and characteristics of the midcycle surge in bioactive and immunoactive luteinizing hormone secretion in normal women: influence of physiological variations in periovulatory ovarian steroid hormone secretion, *J Clin Endocrinol Metab* 75:489, 1992.
212. **Yong EL, Baird DT, Yates R, Reicert LE Jr, Hillier SG**, Hormonal regulation of the growth and steroidogenic function of human granulosa cells, *J Clin Endocrinol Metab* 74:842, 1992.
213. **Judd S, Terry A, Petrucco M, White G**, The source of pulsatile secretion of progesterone during the human follicular phase, *J Clin Endocrinol Metab* 74:299, 1992.
214. **Chandrasekher AY, Brenner RM, Molskness TA, Yu Q, Stouffer RL**, Titrating luteinizing hormone surge requirements for ovulatory changes in primate follicles. II. Progesterone receptor expression in luteinizing granulosa cells, *J Clin Endocrinol Metab* 73:584, 1991.
215. **Chaffkin LM, Luciano AA, Peluso JJ**, Progesterone as an autocrine/paracrine regulator of human granulosa cell proliferation, *J Clin Endocrinol Metab* 75:1404, 1992.
216. **Collins RL, Hodgen GD**, Blockade of the spontaneous midcycle gonadotropin surge in monkeys by RU 486: a progesterone antagonist or agonist? *J Clin Endocrinol Metab* 63:1270, 1986.
217. **Couzinet B, Brailly S, Bouchard P, Schaison G**, Progesterone stimulates luteinizing hormone secretion by acting directly on the pituitary, *J Clin Endocrinol Metab* 74:374, 1992.
218. **Liu JH, Yen SSC**, Induction of midcycle gonadotropin surge by ovarian steroids in women: a critical evaluation, *J Clin Endocrinol Metab* 57:797, 1983.
219. **Hibbert ML, Hess DL, Stouffer RL, Wolf DP, Zelinski-Wooten MB**, Midcycle administration of a progesterone synthesis inhibitor prevents ovulation in primates, *Proc Natl Acad Sci U S A* 93:1897, 1996.
220. **Judd LH, Yen SSC**, Serum androstenedione and testosterone levels during the menstrual cycle, *J Clin Endocrinol Metab* 38:475, 1973.
221. **Adams DB, Gold AR**, Rise in female-initiated sexual activity at ovulation and its suppression by oral contraceptives, *N Engl J Med* 229:1145, 1978.
222. **Hedricks C, Piccinino LJ, Udry JR, Chimbira THK**, Peak coital rate coincides with onset of luteinizing hormone surge, *Fertil Steril* 48:234, 1987.



223. **World Health Organization Task Force Investigators**, Temporal relationships between ovulation and defined changes in the concentration of plasma estradiol-17 $\beta$ , luteinizing hormone, follicle stimulating hormone, and progesterone, *Am J Obstet Gynecol* 138:383, 1980.
224. **Hoff JD, Quigley ME, Yen SS**, Hormonal dynamics at midcycle: a reevaluation, *J Clin Endocrinol Metab* 57:792, 1983.
225. **Zelinski-Wooten MB, Hutchison JS, Chandrasekher YA, Wolf DP, Stouffer RL**, Administration of human luteinizing hormone (hLH) to Macaques after follicular development: further titration of LH surge requirements for ovulatory changes in primate follicles, *J Clin Endocrinol Metab* 75:502, 1992.
226. **Testart J, Frydman R, Roger M**, Seasonal influence of diurnal rhythms in the onset of the plasma luteinizing hormone surge in women, *J Clin Endocrinol Metab* 55:374, 1982.
227. **Fukuda M, Fukuda K, Yding Andersen C, Byskov AG**, Right-sided ovulation favours pregnancy than left-sided ovulation, *Hum Reprod* 15:1921, 2000.
228. **Fukuda M, Fukuda K, Yding Andersen C, Byskov AG**, Contralateral selection of dominant follicle favours pre-embryo development, *Hum Reprod* 11:1958, 1996.
229. **Ecochard R, Gougeon A**, Side of ovulation and cycle characteristics in normally fertile women, *Hum Reprod* 15:752, 2000.
230. **Fukuda M, Fukuda K, Yding Andersen C, Byskov AG**, Characteristics of human ovulation in natural cycles correlated with age and achievement of pregnancy, *Hum Reprod* 16:2501, 2001.
231. **Yoshimura Y, Wallach EE**, Studies on the mechanism(s) of mammalian ovulation, *Fertil Steril* 47:22, 1987.
232. **Gordts S, Campo R, Rombauts L, Brosens I**, Endoscopic visualization of the process of fimbrial ovum retrieval in the human, *Hum Reprod* 13:1425, 1998.
233. **Brannian JD, Woodruff TK, Mather JP, Stouffer RL**, Activin-A inhibits progesterone production by Macaque luteal cells in culture, *J Clin Endocrinol Metab* 75:756, 1992.
234. **Li W, Ho Yeun B, Leung PCK**, Inhibition of progestin accumulation by activin-A in human granulosa cells, *J Clin Endocrinol Metab* 75:285, 1992.
235. **Panigone S, Hsieh M, Fu M, Persani L, Conti M**, Luteinizing hormone signaling in preovulatory follicles involves early activation of the epidermal growth factor receptor pathway, *Mol Endocrinol* 22:924, 2008.
236. **Eppig JJ, Pendola FL, Wigglesworth K, Pendola JK**, Mouse oocytes regulate metabolic cooperativity between granulosa cells and oocytes: amino acid transport, *Biol Reprod* 73:351, 2005.
237. **Gilchrist RB, Ritter LJ, Myllymaa S, Kaivo-Oja N, Dragovic RA, Hickey TE, Ritvos O, Mottershead DG**, Molecular basis of oocyte-paracrine signaling that promotes granulosa cell proliferation, *J Cell Sci* 119:3811, 2006.
238. **Knight PG, Glistler C**, TGF- $\beta$  superfamily members and ovarian follicle development, *Reproduction* 132:191, 2006.
239. **Su Y-Q, Sugiura K, Wigglesworth K, O'Brien MJ, Affourtit JP, Pangas SA, Matzuk MM, Eppig JJ**, Oocyte regulation of metabolic cooperativity between mouse cumulus cells and oocytes: BMP15 and GDF9 control cholesterol biosynthesis in cumulus cells, *Development* 135:111, 2008.
240. **Diaz FJ, Sugiura K, Eppig JJ**, Regulation of Pcsk6 expression during the preantral to antral follicle transition in mice: opposing roles of FSH and oocytes, *Biol Reprod* 78:176, 2008.
241. **Diaz FJ, Wigglesworth K, Eppig JJ**, Oocytes are required for the preantral granulosa cell to cumulus cell transition in mice, *Dev Biol* 305:300, 2007.
242. **Diaz FJ, Wigglesworth K, Eppig JJ**, Oocytes determine cumulus cell lineage in mouse ovarian follicles, *J Cell Sci* 120:1330, 2007.
243. **Sela-Abramovich S, Galiani D, Nevo N, Dekel N**, Inhibition of rat oocyte maturation and ovulation by nitric oxide: mechanism of action, *Biol Reprod* 78:1111, 2008.
244. **Yoshimura Y, Santulli R, Atlas SJ, Fujii S, Wallach EE**, The effects of proteolytic enzymes on in vitro ovulation in the rabbit, *Am J Obstet Gynecol* 157:468, 1987.
245. **Peng X-R, Leonardsson G, Ohlsson M, Hsueh AJW, Ny T**, Gonadotropin induced transient and cell-specific expression of tissue-type plasminogen activator and plasminogen activator inhibitor type 1 leads to a controlled and directed proteolysis during ovulation, *Fibrinolysis* 6(Suppl 14):151, 1992.

246. **Jones PBC, Vernon MW, Muse KN, Curry TE**, Plasminogen activator inhibitor in human preovulatory follicular fluid, *J Clin Endocrinol Metab* 68: 1039, 1989.
247. **Piquette GN, Crabtree ME, El-Danasouri I, Milki A, Polan ML**, Regulation of plasminogen activator inhibitor-1 and -2 messenger ribonucleic acid levels in human cumulus and granulosa-luteal cells, *J Clin Endocrinol Metab* 76:518, 1993.
248. **Piquette GN, Simon C, El Danasouri I, Frances A, Polan ML**, Gene regulation on interleukin-1 beta, interleukin-1 receptor type I, and plasminogen activator inhibitor-1 and -2 in human granulosa-luteal cells, *Fertil Steril* 62:760, 1994.
249. **Chaffin CL, Stouffer RL**, Expression of matrix metalloproteinases and their tissue inhibitor messenger ribonucleic acids in macaque periovulatory granulosa cells: time course and steroid regulation, *Biol Reprod* 61:14, 1999.
250. **Markosyan N, Duffy DM**, Prostaglandin E2 acts via multiple receptors to regulate plasminogen-dependent proteolysis in the primate periovulatory follicle, *Endocrinology* 150:435, 2009.
251. **Lumsden MA, Kelly RW, Templeton AA, Van Look PFA, Swanston IA, Baird DT**, Changes in the concentrations of prostaglandins in preovulatory human follicles after administration of hCG, *J Reprod Fertil* 77:119, 1986.
252. **Espey LL, Tanaka N, Adams RF, Okamura H**, Ovarian hydroxyeicosatetraenoic acids compared with prostanoids and steroids during ovulation in rats, *Am J Physiol* 260:E163, 1991.
253. **Duffy DM, Dozier BL, Seachord CL**, Prostaglandin dehydrogenase and prostaglandin levels in periovulatory follicles: implications for control of primate ovulation by prostaglandin E2, *J Clin Endocrinol Metab* 90:1021, 2005.
254. **Watanabe H, Nagai K, Yamaguchi M, Ikenoue T, Mori N**, Interleukin-1 beta stimulates prostaglandin E2 and F2 alpha synthesis in human ovarian granulosa cells in culture, *Prostaglandins Leukot Essent Fatty Acids* 49:963, 1993.
255. **O'Grady JP, Caldwell BV, Auletta FJ, Speroff L**, The effects of an inhibitor of prostaglandin synthesis (indomethacin) on ovulation, pregnancy, and pseudopregnancy in the rabbit, *Prostaglandins* 1:97, 1972.
256. **Killick S, Elstein M**, Pharmacologic production of luteinized unruptured follicles by prostaglandin synthetase inhibitors, *Fertil Steril* 47:773, 1987.
257. **Pall M, Fridén BE, Brännström M**, Induction of delayed follicular rupture in the human by the selective COX-2 inhibitor rofecoxib: a randomized double-blind study, *Hum Reprod* 16:1323, 2001.
258. **Miyazaki T, Katz E, Dharmarajan AM, Wallach EE, Atlas SJ**, Do prostaglandins lead to ovulation in the rabbit by stimulating proteolytic enzyme activity? *Fertil Steril* 55:1182, 1991.
259. **Ben-Ami I, Freimann S, Armon L, Dantes A, Strassburger D, Friedler S, Raziel A, Seger R, Ron-El R, Amsterdam A**, PGE2 up-regulated EGF-like growth factor biosynthesis in human granulosa cells: new insights into the coordination between PGE2 and LH in ovulation, *Mol Hum Reprod* 12:593, 2006.
260. **Priddy AR, Killick SR, Elstein M, Morris J, Sullivan M, Patel L, Elder M**, The effect of prostaglandin synthetase inhibitors on human preovulatory follicular fluid prostaglandin, thromboxane, and leukotriene concentrations, *J Clin Endocrinol Metab* 71:235, 1990.
261. **Smith G, Roberts R, Hall C, Nuki G**, Reversible ovulatory failure associated with the development of luteinized unruptured follicles in women with inflammatory arthritis taking non-steroidal anti-inflammatory drugs, *Br J Rheumatol* 35:458, 1996.
262. **Chang RJ, Gougeon A, Erickson GF**, Evidence for a neutrophil-interleukin-8 system in human folliculogenesis, *Am J Obstet Gynecol* 178:650, 1998.
263. **Brännström M, Mikuni M, Hedin L**, Intra-ovarian events during follicular development and ovulation, *Hum Reprod* 12(Suppl):51, 1997.
264. **Richards JS, Liu Z, Shimada M**, Immune-like mechanisms in ovulation, *Trends Endocrinol Metab* 19:191, 2008.
265. **Vanderhyden BC, Telfer EE, Eppig JJ**, Mouse oocytes promote proliferation of granulosa cells from preantral and antral follicles in vitro, *Biol Reprod* 46:1196, 1992.
266. **Katt JA, Duncan JA, Herbon L, Barkan A, Marshall JC**, The frequency of gonadotropin-releasing

- hormone stimulation determines the number of pituitary gonadotropin-releasing hormone receptors, *Endocrinology* 116:2113, 1985.
267. **Adams JM, Taylor AE, Schoenfeld DA, Crowley WF Jr, Hall JE**, The midcycle gonadotropin surge in normal women occurs in the face of an unchanging gonadotropin-releasing hormone pulse frequency, *J Clin Endocrinol Metab* 79:858, 1994.
  268. **Caraty A, Antoine C, Delaleu B, Locatelli A, Bouchard P, Gautron JP, Evans NP, Karsch FJ, Padmanabhan V**, Nature and bioactivity of gonadotropin-releasing hormone (GnRH) secreted during the GnRH surge, *Endocrinology* 136:3452, 1995.
  269. **de Koning J**, Gonadotrophin surge-inhibiting/attenuating factor governs luteinizing hormone secretion during the ovarian cycle: physiology and pathology, *Hum Reprod* 10:2854, 1995.
  270. **Fowler PA, Templeton A**, The nature and function of putative gonadotropin surge-attenuating/inhibiting factor (GnSAF/IF), *Endocr Rev* 17:103, 1996.
  271. **Conneely OM, Mulac-Jericevic B, Lydon JP, De Mayo FG**, Reproductive functions of the progesterone receptor isoforms: lessons from knock-out mice, *Mol Cell Endocrinol* 179:97, 2001.
  272. **Conneely OM, Mulac-Jericevic B, Lydon JP**, Progesterone-dependent regulation of female reproductive activity by two distinct progesterone receptor isoforms, *Steroids* 68:771, 2003.
  273. **McClure N, Macpherson AM, Healy DL, Wreford N, Rogers PAW**, An immunohistochemical study of the vascularization of the human Graafian follicle, *Hum Reprod* 9:1401, 1994.
  274. **Dickson SE, Fraser HM**, Inhibition of early luteal angiogenesis by gonadotropin-releasing hormone antagonist treatment in the primate, *J Clin Endocrinol Metab* 85:2339, 2000.
  275. **Wulff C, Wilson H, Largue P, Duncan WC, Armstrong DG, Fraser HM**, Angiogenesis in the human corpus luteum: localization and changes in angiopoietins, tie-2, and vascular endothelial growth factor messenger ribonucleic acid, *J Clin Endocrinol Metab* 85:4302, 2000.
  276. **Smith SK, Lenton EA, Cooke ID**, Plasma gonadotrophin and ovarian steroid concentrations in women with menstrual cycles with short luteal phase, *J Reprod Fertil* 75:363, 1985.
  277. **Golos TG, Soto EA, Tureck RW, Strauss JF III**, Human chorionic gonadotropin and 8-bromo-adenosine 3',5'-monophosphate stimulate [<sup>125</sup>I]low density lipoprotein uptake and metabolism by luteinized human granulosa cells in culture, *J Clin Endocrinol Metab* 61:633, 1985.
  278. **Brannian JD, Shiigi SM, Stouffer RL**, Gonadotropin surge increases fluorescent-tagged low-density lipoprotein uptake by Macaque granulosa cells from preovulatory follicles, *Biol Reprod* 47:355, 1992.
  279. **Vande Wiele RL, Bogumil J, Dyrenfurth I, Ferin M, Jewelewicz R, Warren M, Rizkallah T, Mikhail G**, Mechanisms regulating the menstrual cycle in women, *Recent Prog Horm Res* 26:63, 1970.
  280. **Hutchison JS, Zeleznik AJ**, The rhesus monkey corpus luteum is dependent on pituitary gonadotropin secretion throughout the luteal phase of the menstrual cycle, *Endocrinology* 115:1780, 1984.
  281. **Fraser HM, Lunn SF, Morris KD, Deghenghi R**, Initiation of high dose gonadotrophin-releasing hormone antagonist treatment during the late follicular phase in the macaque abolishes luteal function irrespective of effects upon the luteinizing hormone surge, *Hum Reprod* 12:430, 1997.
  282. **Richardson DW, Goldsmith LT, Pohl CR, Schallenberger E, Knobil E**, The role of prolactin in the regulation of the primate corpus luteum, *J Clin Endocrinol Metab* 60:501, 1985.
  283. **Castro A, Castro O, Troncoso JL, Kohen P, Simón C, Vega M, Devoto L**, Luteal leukocytes are modulators of the steroidogenic process of human mid-luteal cells, *Hum Reprod* 13:1584, 1998.
  284. **Lei ZM, Chegini N, Rao CV**, Quantitative cell composition of human bovine corpora lutea from various reproductive states, *Biol Reprod* 44:1148, 1991.
  285. **Girsh E, Milvae RA, Wang W, Meidan R**, Effect of endothelin-1 on bovine luteal cell function: role in prostaglandin F<sub>2α</sub>-induced antisteroidogenic action, *Endocrinology* 137:1306, 1996.
  286. **Girsh E, Wang W, Mamluk R, Arditi F, Friedman A, Milvae RA, Meidan R**, Regulation of endothelin-1 expression in the bovine corpus luteum: elevation by prostaglandin F<sub>2α</sub>, *Endocrinology* 137:5191, 1996.
  287. **Fraser HM, Dickson SE, Lunn SF, Wulff C, Morris KD, Carroll VA, Bicknell R**, Suppression of luteal angiogenesis in the primate after neutralization of vascular endothelial growth factor, *Endocrinology* 141:95, 2000.

288. **Retamales I, Carrasco I, Troncoso JL, Las Heras J, Devoto L, Vega M**, Morpho-functional study of human luteal cell subpopulations, *Hum Reprod* 9:591, 1994.
289. **Brannian JD, Stouffer RL**, Progesterone production by monkey luteal cell subpopulations at different stages of the menstrual cycle: changes in agonist responsiveness, *Biol Reprod* 44:141, 1991.
290. **Sanders SL, Stouffer RL, Brannian JD**, Androgen production by monkey luteal cell subpopulations at different stages of the menstrual cycle, *J Clin Endocrinol Metab* 81:591, 1996.
291. **Maas S, Jarry H, Teichmann A, Rath W, Kuhn W, Wuttke W**, Paracrine actions of oxytocin, prostaglandin F2 $\alpha$ , and estradiol within the human corpus luteum, *J Clin Endocrinol Metab* 74:306, 1992.
292. **Bogan RL, Murphy MJ, Stouffer RL, Hennebold JD**, Prostaglandin synthesis, metabolism, and signaling potential in the Rhesus Macaque corpus luteum throughout the luteal phase of the menstrual cycle, *Endocrinology* 149:5861, 2008.
293. **Ravindranath N, Little-Ihrig L, Benyo DF, Zeleznik AJ**, Role of luteinizing hormone in the expression of cholesterol side-chain cleavage cytochrome P450 and 3-hydroxysteroid dehydrogenase 5-4 isomerase messenger ribonucleic acids in the primate corpus luteum, *Endocrinology* 131:2065, 1992.
294. **Chaffin CL, Dissen GA, Stouffer RL**, Hormonal regulation of steroidogenic enzyme expression in granulosa cells during the peri-ovulatory interval in monkeys, *Mol Hum Reprod* 6:11, 2000.
295. **Devoto L, Kohen P, Gonzalez R, Castro, O, Retamales I, Vega M, Carvallo P, Christensen LK, Strauss JF III**, Expression of steroidogenic acute regulatory protein in the human corpus luteum throughout the luteal phase, *J Clin Endocrinol Metab* 86:5633, 2001.
296. **Brannian JD, Stouffer RL**, Cellular approaches to understanding the function and regulation of the primate corpus luteum, *Semin Reprod Endocrinol* 9:341, 1991.
297. **Baerwald AR, Adams G, Pierson R**, Characteristics of ovarian follicular wave dynamics in women, *Biol Reprod* 69:1023, 2003.
298. **Ginther OJ, Beg MA, Gastal EL, Gastal MO, Baerwald AR, Pierson RA**, Systemic concentration of hormones during the development of follicular waves in mares and women: a comparative study, *Reproduction* 130:379, 2005.
299. **Filicori M, Butler JP, Crowley WF**, Neuroendocrine regulation of the corpus luteum in the human: evidence for pulsatile progesterone secretion, *J Clin Invest* 73:1638, 1984.
300. **Rothchild I**, The corpus luteum revisited: are the paradoxical effects of RU486 a clue to how progesterone stimulates its own secretion? *Biol Reprod* 55:1, 1996.
301. **Stouffer RL**, Progesterone as a mediator of gonadotrophin action in the corpus luteum: beyond steroidogenesis, *Hum Reprod Update* 9:99, 2003.
302. **Peluso JJ, Romak J, Liu X**, Progesterone receptor membrane component-1 (PGRMC1) is the mediator of progesterone's antiapoptotic action in spontaneously immortalized granulosa cells as revealed by PGRMC1 small interfering ribonucleic acid treatment and functional analysis of PGRMC1 mutations, *Endocrinology* 149:534, 2008.
303. **Lenton EA, Landgren B, Sexton L, Harper R**, Normal variation in the length of the follicular phase of the menstrual cycle: effect of chronological age, *Br J Obstet Gynaecol* 91:681, 1984.
304. **Gore BZ, Caldwell B, Speroff L**, Estrogen-induced human luteolysis, *J Clin Endocrinol Metab* 36:615, 1973.
305. **Auletta FJ, Flint APF**, Mechanisms controlling corpus luteum function in sheep, cows, nonhuman primates, and women especially in relation to the time of luteolysis, *Endocr Rev* 9:88, 1988.
306. **Friden BE, Runesson E, Hahlin M, Brannstrom M**, Evidence for nitric oxide acting as a luteolytic factor in the human corpus luteum, *Mol Hum Reprod* 6:397, 2000.
307. **Vega M, Urrutia L, Iniguez G, Gabler F, Devoto L, Johnson MC**, Nitric oxide induces apoptosis in the human corpus luteum in vitro, *Mol Hum Reprod* 6: 681, 2000.
308. **McCracken JA, Custer EE, Lamsa JC**, Luteolysis: a neuroendocrine-mediated event, *Physiol Rev* 79:263, 1999.
309. **Priyanka S, Jayaram P, Sridaran R, Medhamurthy R**, Genome-wide gene expression analysis reveals a dynamic interplay between luteotropic and luteolytic factors in the regulation of corpus luteum function in the Bonnet monkey (*Macaca radiata*), *Endocrinology* 150:1473, 2009.

310. **Miceli F, Minici F, Garcia Pardo M, Navarra P, Proto C, Mancuso S, Lanzone A, Apa R**, Endothelins enhance prostaglandin (PGE<sub>2</sub>) and PGF(2 $\alpha$ ) biosynthesis and release by human luteal cells: evidence for a new paracrine/autocrine regulation of luteal function, *J Clin Endocrinol Metab* 86:811, 2001.
311. **Shikone T, Yamoto M, Kokawa K, Yamashita K, Nishimori K, Nakano R**, Apoptosis of human corpora lutea during cyclic luteal regression and early pregnancy, *J Clin Endocrinol Metab* 81:2376, 1996.
312. **Peluffo MC, Young KA, Hennebold JD, Stouffer RL**, Expression and regulation of tumor necrosis factor (TNF) and TNF-receptor family members in the Macaque corpus luteum during the menstrual cycle, *Mol Reprod Dev* 76:367, 2009.
313. **Grazul-Bilska AT, Redmer DA, Reynolds LP**, Effects of luteinizing hormone and prostaglandin F<sub>2</sub> $\alpha$  on gap junctional intercellular communication of ovine luteal cells throughout the estrous cycle, *Endocrine* 5:225, 1996.
314. **Zeleznik AJ, Little-Ihrig LL**, Effect of reduced luteinizing hormone concentrations on corpus luteum function during the menstrual cycle of rhesus monkeys, *Endocrinology* 125:2237, 1990.
315. **Duncan WC, McNeilly AS, Illingworth PJ**, The effect of luteal "rescue" on the expression and localization of matrix metalloproteinases and their tissue inhibitors in the human corpus luteum, *J Clin Endocrinol Metab* 83:2470, 1998.
316. **O'Sullivan MJ, Stamouli A, Thomas EJ, Richardson MC**, Gonadotrophin regulation of production of tissue inhibitor of metalloproteinases-1 by luteinized human granulosa cells: a potential mechanism for luteal rescue, *Mol Hum Reprod* 3:405, 1997.
317. **Myers M, Gay E, McNeilly AS, Fraser HM, Duncan WC**, In vitro evidence suggests activin-A may promote tissue remodeling associated with human luteolysis, *Endocrinology* 148:3730, 2007.
318. **Lopata A, Hay D**, The surplus human embryo: its potential for growth, blastulation, hatching, and human chorionic gonadotropin production in culture, *Fertil Steril* 51:984, 1989.
319. **Bonduelle M, Dodd R, Liebaers I, Steirteghem A, Williamson R, Akhurst R**, Chorionic gonadotropin-b mRNA, a trophoblast marker, is expressed in human 8-cell embryos derived from tripronucleate zygotes, *Hum Reprod* 3:909, 1988.
320. **Stewart DR, Overstreet JW, Nakajima ST, Lasley BL**, Enhanced ovarian steroid secretion before implantation in early human pregnancy, *J Clin Endocrinol Metab* 76:1470, 1993.
321. **Csapo AL, Pulkkinen MO, Wiest WG**, Effects of luteectomy and progesterone replacement in early pregnant patients, *Am J Obstet Gynecol* 115:759, 1973.
322. **Stevens VC**, Potential control of fertility in women by immunization with HCG, *Res Reprod* 7:1, 1975.
323. **Christenson LK, Stouffer RL**, Proliferation of microvascular endothelial cells in the primate corpus luteum during the menstrual cycle and simulated early pregnancy, *Endocrinology* 137:367, 1996.
324. **Bassett SG, Little-Ihrig LL, Mason JI, Zeleznik AJ**, Expression of messenger ribonucleic acids that encode for 3-hydroxysteroid dehydrogenase and cholesterol side-chain cleavage enzyme throughout the luteal phase of the Macaque menstrual cycle, *J Clin Endocrinol Metab* 72:362, 1991.
325. **Roseff SJ, Bangah ML, Kettel LM, Vale W, Rivier J, Burger HG, Yen SS**, Dynamic changes in circulating inhibin levels during the luteal-follicular transition of the human menstrual cycle, *J Clin Endocrinol Metab* 69:1033, 1989.
326. **Jia X-C, Kessel B, Yen SSC, Tucker EM, Hsueh AJW**, Serum bioactive follicle-stimulating hormone during the human menstrual cycle and in hyper- and hypogonadotropic states: application of a sensitive granulosa cell aromatase bioassay, *J Clin Endocrinol Metab* 62:1243, 1986.
327. **Schneyer AL, Sluss PM, Whitcomb RW, Hall JE, Crowley WF Jr, Freeman RG**, Development of a radioligand receptor assay for measuring follitropin in serum: application to premature ovarian failure, *Clin Chem* 37:508, 1991.
328. **Molskness TA, Woodruff TK, Hess DL, Dahl KD, Stouffer RL**, Recombinant human inhibin-A administered early in the menstrual cycle alters concurrent pituitary and follicular, plus subsequent luteal, function in Rhesus monkeys, *J Clin Endocrinol Metab* 81:4002, 1996.
329. **Besecke LM, Guendner MJ, Schneyer AL, Bauer-Dantoin AC, Jameson JL, Weiss J**, Gonadotropin-releasing hormone regulates follicle-stimulating hormone-b gene expression through an activin/follistatin autocrine or paracrine loop, *Endocrinology* 137:3667, 1996.

330. **Wang Y, Fortin J, Lamba P, Bonomi M, Persani L, Roberson MS, Bernard DJ**, Activator protein-1 and Smad proteins synergistically regulate human follicle-stimulating hormone  $\beta$ -promoter activity, *Endocrinology* 149:5577, 2008.
331. **Welt CK, Pagan YL, Smith PC, Rado KB, Hall JE**, Control of follicle-stimulating hormone by estradiol and the inhibins: critical role of estradiol at the hypothalamus during the luteal-follicular transition, *J Clin Endocrinol Metab* 88:1766, 2003.
332. **Le Nestour E, Marraoui J, Lahlou N, Roger M, de Ziegler D, Bouchard PH**, Role of estradiol in the rise in follicle-stimulating hormone levels during the luteal-follicular transition, *J Clin Endocrinol Metab* 77:439, 1993.
333. **Treloar AE, Boynton RE, Borghild GB, Brown BW**, Variation of the human menstrual cycle through reproductive life, *Int J Fertil* 12:77, 1967.
334. **Vollman RF**, The menstrual cycle, In: Friedman E, ed. *Major Problems in Obstetrics and Gynecology*, W.B. Saunders Co., Philadelphia, 1977.
335. **Lee SJ, Lenton EA, Sexton L, Cooke ID**, The effect of age on the cyclical patterns of plasma LH, FSH, oestradiol and progesterone in women with regular menstrual cycles, *Hum Reprod* 3:851, 1988.
336. **Hughes EG, Robertson DM, Handelsman DJ, Hayward S, Healy DL, de Kretser DM**, Inhibin and estradiol responses to ovarian hyperstimulation: effects of age and predictive value for in vitro fertilization outcome, *J Clin Endocrinol Metab* 70:358, 1990.
337. **Metcalf MG, Livesay JH**, Gonadotropin excretion in fertile women: effect of age and the onset of the menopausal transition, *J Endocrinol* 105:357, 1985.
338. **Klein NA, Battaglia DE, Fujimoto VY, Davis GS, Bremmer WJ, Soules MR**, Reproductive aging: accelerated ovarian follicular development associated with a monotropic follicle-stimulating hormone rise in normal older women, *J Clin Endocrinol Metab* 81:1038, 1996.
339. **Cha KY, Koo JJ, Ko JJ, Choi DH, Han SY, Yoon TK**, Pregnancy after IVF of human follicular oocytes collected from nonstimulated cycles, their culture in vitro and their transfer in a donor oocyte program, *Fertil Steril* 55:109, 1991.
340. **Richardson SJ, Senikas V, Nelson JF**, Follicular depletion during the menopausal transition—evidence for accelerated loss and ultimate exhaustion, *J Clin Endocrinol Metab* 65:1231, 1987.
341. **Westergaard CG, Byskov AG, Andersen CY**, Morphometric characteristics of the primordial to primary follicle transition in the human ovary in relation to age, *Hum Reprod* 22:2225, 2007.
342. **Klein NA, Battaglia DE, Miller PB, Branigan EF, Giudice LC, Soules MR**, Ovarian follicular development and the follicular fluid hormones and growth factors in normal women of advanced reproductive age, *J Clin Endocrinol Metab* 81:1946, 1996.
343. **Collett ME, Wertenberger GE, Fiske VM**, The effect of age upon the pattern of the menstrual cycle, *Fertil Steril* 5:437, 1954.
344. **Chiazze L Jr, Brayer FT, Macisco JJ Jr, Parker MP, Duffy BJ**, The length and variability of the human menstrual cycle, *JAMA* 203:377, 1968.
345. **Belsey EM, Pinol APY**, Menstrual bleeding patterns in untreated women. Task force on long-acting systemic agents for fertility regulation, *Contraception* 55:57, 1997.
346. **Taffe JR, Dennerstein L**, Menstrual patterns leading to the final menstrual period, *Menopause* 9:32, 2002.
347. **O'Connor KA, Holman DJ, Wood JW**, Menstrual cycle variability and the perimenopause, *Am J Hum Biol* 13:465, 2001.
348. **Symons JP, Sowers MF, Harlow SD**, Relationship of body composition measures and menstrual cycle length, *Ann Hum Biol* 24:107, 1997.
349. **Rowland AS, Baird DD, Long S, Wegienka G, Harlow SD, Alavanja M, Sandler DP**, Influence of medical conditions and lifestyle factors on the menstrual cycle, *Epidemiology* 13:668, 2002.
350. **Munster K, Schmidt L, Helm P**, Length and variation in the menstrual cycle—a cross-sectional study from a Danish county, *Br J Obstet Gynaecol* 99:422, 1992.

---

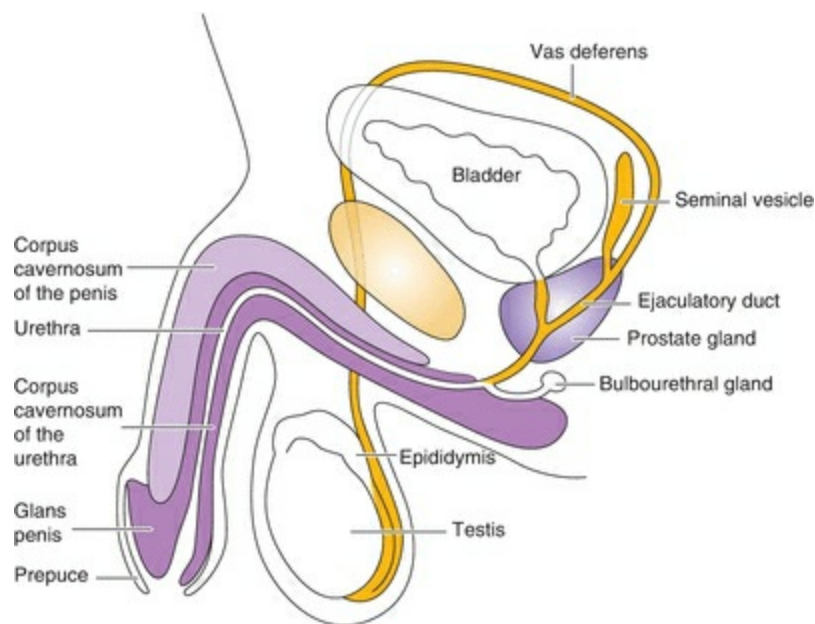
# Conception - Sperm and Egg Transport, Fertilization, Implantation and Early Embryogenesis

Among his many accomplishments, Galileo Galilei gave to science, in 1609, two important instruments, the telescope and the microscope.<sup>1</sup> Anton van Leeuwenhoek of Delft, Holland, was fascinated by Galileo's microscope. Leeuwenhoek was a draper and had no medical or scientific training, yet he became a fellow of the Royal Society of London to which he submitted 375 scientific papers. In 1677, Leeuwenhoek described (fairly accurately) the "little animals of the sperm." It was another 198 years before Wilhelm August Oscar Hertwig, in Germany, demonstrated the union of sperm and egg, fertilization, in the sea urchin.

The coming together of sperm and egg is one of the essentials of reproduction; however, the remote site of this event and the enclosed origins of the participants made fertilization a difficult subject for study. This changed with the advent of in vitro fertilization. Greater understanding of sperm and egg development and union is one of the major benefits of the clinical application of the assisted reproductive technologies. This chapter examines the mechanisms involved in sperm and egg transport, fertilization, and implantation.

# SPERM TRANSPORT

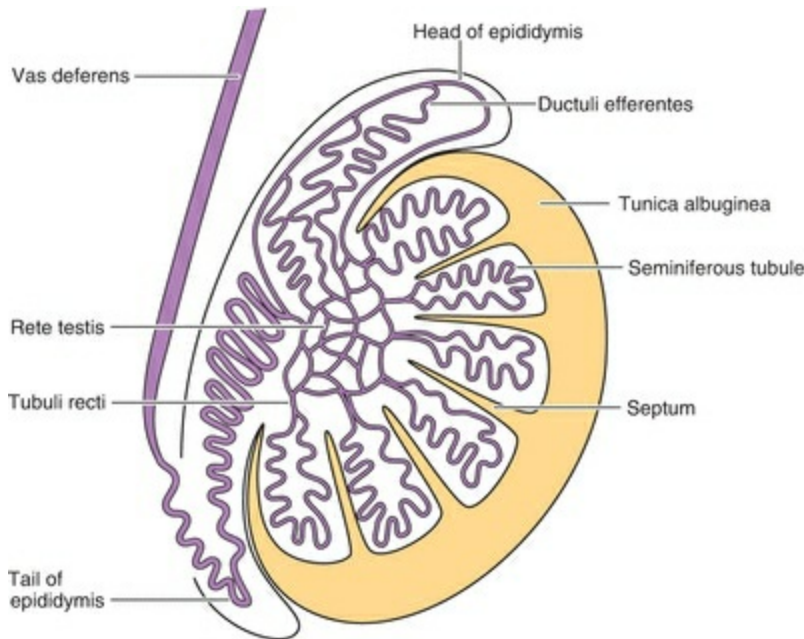
The evolution of scrotal mammals and the adoption of internal fertilization are associated with sperm maturation that occurs outside of the testes. This includes epididymal maturation in the male and capacitation in the female before fertilization. The need for capacitation (the final step required to acquire the ability to fertilize) may be an evolutionary consequence of the development of a storage system for inactive sperm in the caudal epididymis<sup>2</sup> (Figure 6.1).



**FIGURE 6.1**

The epididymis is over 6 m long in men, approximately 80 m in stallions, and over one hundred times the body length in a mouse; however, there are few functions known aside from sperm storage and nutrition. The epididymis is divided into three segments, the caput (head) where the sperm begin their process of maturation, the corpus (body) where maturation continues, and the cauda (tail), the site of final maturation and storage.<sup>3</sup> The sperm reach the caudal epididymis approximately 72 days after the initiation of spermatogenesis. At this time, the head of the sperm contains a membrane-bound nucleus capped by the acrosome, a large vesicle of proteolytic enzymes. The inner acrosomal membrane is closely apposed to the nuclear membrane, and the outer acrosomal membrane is next to the surface plasma membrane. The flagellum is a complex structure of microtubules and fibers, surrounded at the proximal end by mitochondria. Motility and the ability to fertilize are acquired gradually as the sperm pass into the epididymis (Figure 6.2).





**FIGURE 6.2**

The caudal epididymis stores sperm available for ejaculation. The ability to store functional sperm provides a capacity for repetitive fertile ejaculations. Preservation of optimal sperm function during this period of storage requires adequate testosterone levels in the circulation and maintenance of the normal scrotal temperature.<sup>4</sup> The importance of temperature is emphasized by the correlation of reduced numbers of sperm associated with episodes of body fever. The evolution of the scrotum served the purpose of achieving the cooler temperatures required for effective sperm storage.

In all mammalian species that have been studied except humans, it is necessary for spermatozoa to pass through the epididymis in order to develop two characteristics, which are essential to achieve fertilization: the capacity for motility and the ability to bind to the zona pellucida and penetrate the oocyte. There is evidence that the maturation process occurring in the epididymis involves modification of the sperm surface by epididymal proteins that are synthesized and secreted under the control of androgens.<sup>5</sup> Most of the maturational changes occur in the proximal epididymis, where surface proteins that must be removed in the process of capacitation, discussed later, are acquired by the sperm. It can be argued that in humans, the epididymis is not necessary for posttesticular sperm maturation and that its role is limited to storage because sperm that have never passed through the epididymis and that have been obtained from the vasa efferentia in men with a congenital absence of the vas deferens can fertilize the human oocyte in vitro and result in pregnancy with live birth.<sup>6</sup> Moreover, patients have achieved conception after anastomosis of the vas deferens to a seminiferous tubule<sup>7</sup> or the rete testis.<sup>8</sup> In a similar context, the injection of sperm obtained by testicular biopsy

directly into an oocyte (intracytoplasmic sperm injection [ICSI]) is very successful in achieving fertilization and pregnancy;<sup>9</sup> this observation, however, should be interpreted with caution, because with direct injection into the oocyte, surface protein action at the oocyte membrane is bypassed.

The use of sperm from men with sperm abnormalities should be pursued with some caution. Men with severe oligospermia or azoospermia should receive appropriate genetic counseling and should be offered testing for Y chromosome microdeletions before their sperm are used for ICSI. Sperm obtained from men with Y chromosome microdeletions involving the AZFc region of Yq11 can transmit the deletion to male children, who then will also likely be infertile. In addition, men with certain Y microdeletions, including a portion of AZFc, may have an increased susceptibility for developing testicular germ cell tumors. The outcome in subsequent generations must be assessed and appropriate genetic screening must be developed to avoid the transmission of subtle but important genetic alterations.

Semen forms a gel almost immediately following ejaculation but then is liquefied in 20–30 minutes by enzymes derived from the prostate gland. The alkaline pH of semen provides protection for the sperm from the acid environment of the vagina. This protection is transient, and most sperm left in the vagina are immobilized within 2 hours. The more fortunate sperm, by their own motility, gain entrance into the tongues of cervical mucus that layer over the ectocervix. These are the sperm that enter the uterus; the seminal plasma is left behind in the vagina. This entry is rapid, and sperm have been found in mucus within 90 seconds of ejaculation.<sup>10</sup> The destruction of all sperm in the vagina 5 minutes after ejaculation does not interfere with fertilization in the rabbit, further attesting to the rapidity of transport.<sup>11</sup>

Contractions of the female reproductive tract occur during coitus, and these contractions may be important for entry of sperm into the cervical mucus and further transport.

Presumably successful entry is the result of combined female and male forces (the flagellar activity of the sperm). The success of therapeutic insemination, however, indicates that coitus and female orgasm are not essential for sperm transport.

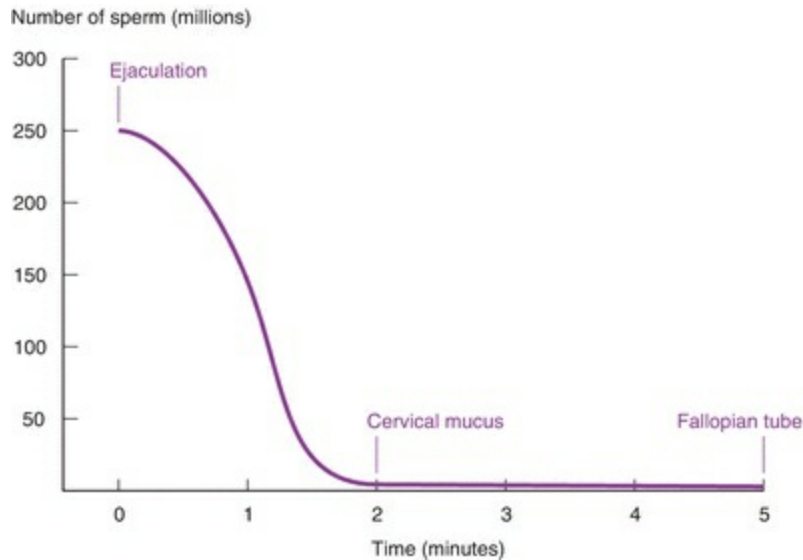
The sperm swim and migrate through pores in the cervical mucus that are smaller than the sperm head; therefore, the sperm must actively push their way through the mucus.<sup>12</sup> One cause of infertility, presumably, is impaired sperm movement that prevents this transport through the mucus. This movement is probably also influenced by the interaction between the mucus and the surface properties of the sperm head.<sup>13</sup> Abnormal morphology of the sperm head is often associated with impaired flagellar function; however, abnormal head morphology alone can be a cause of poor mucus

penetration.<sup>14,15</sup> A sperm coating protein (beta-defensin 126), acquired in the caudal epididymis, carries a high negative charge and is critical for movement through the cervical mucus.<sup>16</sup> It is generally believed that the cervical mucus has a filtering action; abnormal and less “capable” sperm have difficulty getting through.<sup>17</sup>

Uterine contractions and sperm motility propel the sperm upward, and in the human, sperm can be found in the tube 5 minutes after insemination.<sup>18</sup> Labeled albumin is present in the tubes within 30 seconds after intrauterine instillation.<sup>19</sup> It is possible that the first sperm to enter the tube are at a disadvantage. In the rabbit, these early sperm have only poor motility, and there is frequent disruption of the head membranes.<sup>20</sup> The sperm in this vanguard are unlikely to achieve fertilization. Other sperm that have colonized the cervical mucus and the cervical crypts then make their way more slowly to the ampulla of the tube in order to meet the egg. The number of sperm in the cervical mucus is relatively constant for 24 hours after coitus, and after 48 hours, there are relatively few remaining in the mucus.<sup>21</sup> Although the isthmus region of the fallopian tube functions as a sperm reservoir in many species, this does not appear to be the case in human,<sup>22</sup> where the cervix serves as a reservoir, providing a supply of sperm for up to 72 hours.

Human sperm have been found in the fallopian tube as long as 80 hours after intercourse, and these sperm can still perform fertilization normally with zona-free hamster oocytes.<sup>23</sup> In animals, the fertilizable lifespan is usually one-half the motile lifespan.

The **attrition in sperm** numbers from vagina to tube is substantial.<sup>24</sup> Of an average of 200–300 million sperm deposited in the vagina, at most only a few hundred (rarely reaching 1,000), and often less, achieve proximity to the egg (**Figure 6.3**).<sup>22</sup> Greater numbers are observed in the tubal ampulla at the time of ovulation. The major loss occurs in the vagina, with expulsion of semen from the introitus playing an important role. Other causes for loss are digestion of sperm by vaginal enzymes and phagocytosis of sperm along the reproductive tract. There are also reports of sperm burrowing into or being engulfed by endometrial cells. Many sperm continue past the oocyte to be lost into the peritoneal cavity.



**FIGURE 6.3**

Within the fallopian tube, sperm that are not yet capacitated are bound to the epithelial cells. When these sperm release and undergo capacitation, they display a new pattern of movement that has been called **hyperactivated motility**.<sup>25,26</sup> This motility may be influenced by an interaction with the tubal epithelium that results in greater speed and better direction as well as prevention of attachment and entrapment.

# Structure of the Cervical Mucus

The cervical mucus is a complex structure that is not homogeneous.<sup>27</sup> The mucus is secreted in granular form, and a networked structure of the mucus is formed in the cervical canal. Thus, not all areas of the cervical mucus are equally penetrable by the sperm. It is proposed, based on animal studies, that the outward flow of the cervical mucus establishes a linear alignment of parallel strands that direct the sperm upward. Pressurization of the mucus by contractions of the uterus further aids this alignment and may contribute to the speed of sperm transport. Responding to the midcycle estrogen peak, cervical mucus production, water content, and space between its large glycoproteins reach a maximum in the immediate preovulatory period. The process of capacitation is initiated but not completed during the sperm's passage through the cervix.

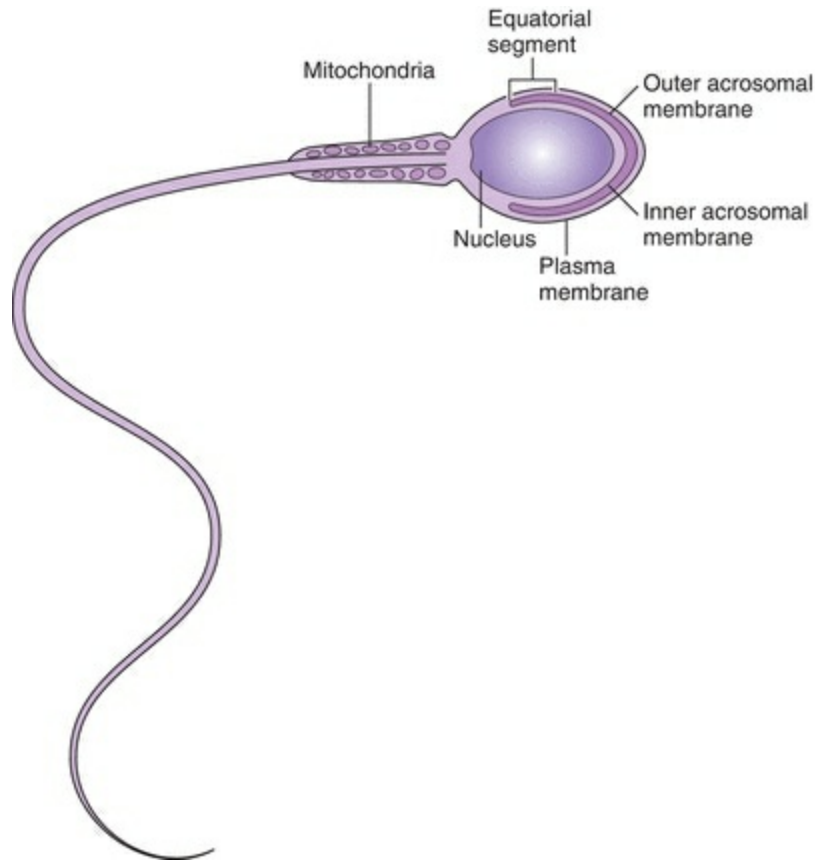
# Capacitation

The discovery, in 1951, that rabbit and rat spermatozoa must spend some hours in the female reproductive tract before acquiring the capacity to penetrate ova stimulated intensive research efforts to delineate the environmental conditions required for this change in the sperm to occur.<sup>28,29</sup> The process by which the sperm were transformed was called **capacitation, the cellular and molecular changes that ejaculated spermatozoa must undergo in order to fertilize.**<sup>30</sup> Attention was focused on the hormonal and time requirements and the potential for in vitro capacitation. Successful experiments to capacitate sperm outside of the female body were subsequently conducted in hamsters<sup>31</sup> and in mice,<sup>32</sup> pioneering the field of in vitro fertilization.

Capacitation occurs while the sperm are in the fallopian tube and is characterized by three accomplishments:

- 1. The ability to bind to the zona pellucida.**
- 2. The ability to undergo the acrosome reaction.**
- 3. The acquisition of hypermotility.**

Capacitation changes the surface characteristics of sperm, as exemplified by removal of seminal plasma factors that coat the surface of the sperm, modification of the surface charge, and restriction of receptor mobility. The protein beta-defensin 126 (DEFB126), derived from the epididymis, is the major coating protein of sperm that facilitates movement through the cervical mucus; its release from the sperm head is essential in order for the sperm to bind to the zona pellucida of the ovum.<sup>16,33</sup> Sperm proteomics have demonstrated a huge collection of receptors coated on the surface of sperm.<sup>34,35</sup> The purpose of the coating proteins may be to produce a reservoir of sperm in the fallopian tubes by promoting the binding of sperm to tubal epithelial cells (**Figure 6.4**).<sup>36</sup>



**FIGURE 6.4**

The surface changes are associated with modifications of sperm cell membrane sterols, lipids, and glycoproteins that cause decreased stability of the plasma membrane and the membrane lying immediately under it, the outer acrosomal membrane. The membranes undergo further, more striking modifications when capacitated sperm reach the vicinity of an oocyte or when they are incubated in follicular fluid. There is a breakdown and merging of the plasma membrane and the outer acrosomal membrane, the **acrosome reaction**.<sup>37</sup> This allows egress of the enzyme contents of the acrosome, the cap-like structure that covers the sperm nucleus. These enzymes, which include hyaluronidase, a neuraminidase-like factor, cumulus-dispersing enzyme, and a protease called acrosin, are all thought to play roles in sperm penetration of the egg investments. The changes in the sperm head membranes also prepare the sperm for fusion with the egg membrane. It is the inner acrosomal membrane that fuses with the oocyte plasma membrane. The acrosome reaction can be induced by zona pellucida proteins of the oocyte and by human follicular fluid in vitro.<sup>38,39</sup> In addition, capacitation endows the sperm with hypermotility, and the increased velocity of the sperm is a very critical factor in achieving zona penetration.<sup>25</sup>

During capacitation, removal of cholesterol from sperm plasma membrane by

albumin occurs first. This increases membrane permeability, which is followed by a critical increase in intracellular calcium concentration due to an influx of extracellular calcium, believed to be induced by progesterone. The events that constitute the process of capacitation are regulated by the redox status of the sperm cell.<sup>40,41</sup> The calcium influx activates secondary messenger systems, activating cAMP and redox reactions. Such activities lead to the phosphorylation of proteins, especially tyrosine residues, an absolute requirement for capacitation.<sup>42</sup> Sperm are stimulated to undergo capacitation when they encounter the alkaline change in pH at the time of ovulation, a response of the fallopian tubes to the midcycle hormonal changes.

Although capacitation classically has been defined as a change sperm undergo in the female reproductive tract, specifically in the fallopian tubes, it is apparent that sperm of some species, including the human, can acquire the ability to fertilize after a short incubation in defined media and without residence in the female reproductive tract. Therefore, success with assisted reproductive technologies is possible. In vitro capacitation requires a culture medium that is a balanced salt solution containing energy substrates such as lactate, pyruvate, and glucose and a protein such as albumin, or a biologic fluid such as serum or follicular fluid. Sperm-washing procedures probably remove factors that coat the surface of the sperm, one of the initial steps in capacitation. The removal of cholesterol from the sperm membrane is believed to prepare the sperm membrane for the acrosome reaction.<sup>43</sup> The loss of cholesterol regulates the expression of sperm cell membrane surface lectins that are involved in sperm surface receptors for the zona pellucida.<sup>44</sup> The time required for in vitro capacitation is approximately 2 hours.<sup>45</sup>

The final dash to the oocyte is aided by the increased motility due to the state of hyperactivity. This change in motility can be measured by an increase in velocity and flagellar beat amplitude. Perhaps the increase in thrust gained by this hyperactivity is necessary for avoiding attachment to tubal epithelium and achieving penetration of the cumulus and zona pellucida.

## Key Points: Steps in Sperm Transport

- Approximately 72 days are required to produce spermatozoa, a time period followed by storage in the epididymis prior to ejaculation.
- Sperm enter the cervical mucus and then the fallopian tubes within minutes, but only a few hundred sperm or less reach the oocyte. The cervix serves as a reservoir of sperm for up to 72 hours.
- Capacitation, a process initiated during the sperm's passage through the cervix and completed in the fallopian tube or during in vitro incubation in an appropriate



medium, is characterized by the acquired ability of sperm to undergo the acrosome reaction, to bind to the zona pellucida, and to acquire hyperactivated motility.

- The acrosome reaction is due to the modification and breakdown, followed by a merger, of the sperm cell membrane and the outer acrosomal membrane, allowing the release of enzymes and changes in the inner acrosomal membrane, necessary for fusion with the oocyte cell membrane.

# EGG TRANSPORT

---

The oocyte, at the time of ovulation, is surrounded by cumulus cells (the **cumulus oophorus**) that attach the oocyte to the granulosa cells that line the wall of the follicle. The **zona pellucida**, a noncellular porous layer of glycoproteins secreted by the oocyte, separates the oocyte from the cumulus cells. The cumulus cells communicate metabolically with the oocyte by means of **gap junctions**. In response to the midcycle surge in luteinizing hormone (LH), maturation of the oocyte proceeds with the resumption of meiosis as the oocyte completes the first meiotic division, enters into the second meiotic division, and arrests in the second metaphase. Just before ovulation, the cumulus cells retract their cellular contacts from the oocyte. The disruption of the gap junctions induces maturation and migration of the cortical granules to the outer cortex of the oocyte.<sup>46</sup> Prior to ovulation, the oocyte and its cumulus mass of cells prepare to leave their long residence in the ovary by becoming detached from the follicular wall.

Egg transport encompasses the period of time from ovulation to the entry of the morula into the uterus. The egg can be fertilized only during the early stages of its sojourn in the fallopian tube. Within 2–3 minutes of ovulation in some animals, the cumulus and oocyte are in the ampulla of the fallopian tube. It takes longer in humans.

In rats and mice, the ovary and distal portion of the tube are covered by a common fluid-filled sac. Ovulated eggs are carried by fluid currents to the fimbriated end of the tube. In contrast, in primates, including humans, the ovulated eggs adhere with their cumulus mass of follicular cells to the surface of the ovary. The fimbriated end of the tube sweeps over the ovary in order to pick up the egg. Entry into the tube is facilitated by muscular movements that bring the fimbriae into contact with the surface of the ovary. Variations in this pattern surely exist, as evidenced by women who achieve pregnancy despite having only one ovary and a single tube located on the contralateral side. Furthermore, eggs deposited in the cul-de-sac by transvaginal injection are picked up by the tubes.<sup>47</sup>

Although there can be a small negative pressure in the tube in association with muscle contractions, oocyte pickup is not dependent on a suction effect secondary to this negative pressure. Ligation of the tube just proximal to the fimbriae does not interfere with pickup.<sup>48</sup>

In order to successfully achieve a pregnancy, not only anatomically patent tubes but also a complex system of tubal transport must be operational to allow a timely favorable interaction between gametes and subsequently provide a supporting conduit for the developing conceptus to reach the uterus. Three different components, (1) ciliary motion, (2) muscular contractility, and (3) tubal fluid, all contribute to varying degrees to effective tubal transport.

The fallopian tube is composed of three layers: an inner mucosal surface, a wall of smooth muscle, and an outer serosal layer. It is lined by a single layer of simple columnar epithelium, composed of nonciliated cells and ciliated cells, that undergoes cyclic changes comparable to the endometrium, in response to the ovarian steroids during the menstrual cycle.<sup>49</sup> These changes can be evident as a higher percentage of ciliated cells in the follicular phase, with gradual transition into a secretory cell–dominant pattern in the luteal phase of the cycle. The nonciliated cells are characterized by major secretory activity during the follicular phase of the cycle, culminating in the release of cytoplasmic components during the passage of the egg, perhaps providing important metabolic factors for transport and implantation. The cilia on the surface of the fimbriae (where they are present in greater concentrations) display adhesive sites, and these seem to have prime responsibility for the initial movement of the egg into the tube. This movement is dependent on the presence of follicular cumulus cells surrounding the egg, because removal of these cells prior to egg pickup prevents effective egg transport.

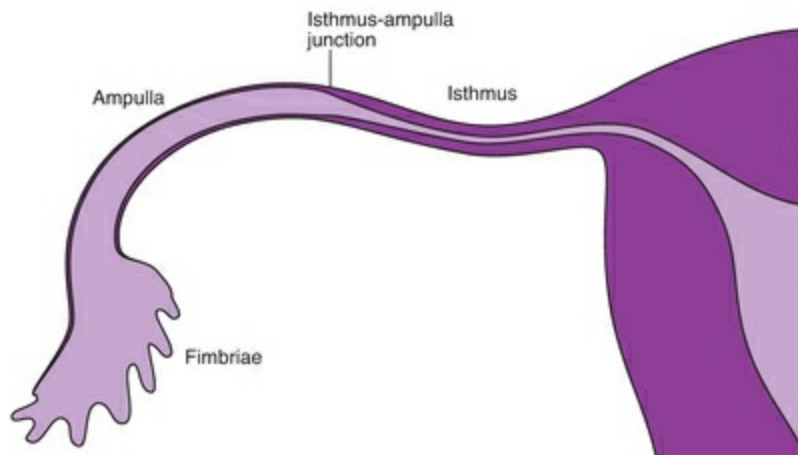
In the ampulla of the tube, the many cilia beat synchronously in the direction of the uterus, and in the fimbria, the ciliary beat is faster in the secretory phase of the menstrual cycle.<sup>50</sup> In women and monkeys, this unidirectional beat is also found in the isthmus of the tube. Various hormonal and neuronal factors have been shown to modulate the ciliary activity as shown by changes in ciliary beat frequency in the fallopian tube. These include adrenergic and cholinergic stimulation, ovarian steroids, prostaglandins, angiotensin II, and adrenomedullin. The specific contribution of the cilia to egg transport in the ampulla and isthmus is an unresolved question. Most investigators have credited muscular contractions of the tubes as the primary force for moving the egg.<sup>51</sup> However, interference with muscle contractility in the rabbit did not block egg transport, implying that the cilia alone are adequate for transporting the ovum.<sup>52</sup> Reversing a segment of the ampulla of the tube so that the cilia in this segment beat toward the ovary interferes with pregnancy in the rabbit without blocking fertilization. The fertilized ova are arrested when they come in contact with the transposed area.<sup>53</sup> This suggests that ciliary beating is crucial for egg transport. Spontaneous pregnancies have been reported in women who suffer from Kartagener syndrome (primary ciliary dyskinesia) in which there is a congenital absence of dynein arms (a protein structure associated with motility) in all bodily cilia, and thus the cilia do not beat.<sup>54</sup> However, motility of cilia in the tube may be disordered and not totally absent. Nevertheless, the pregnancies in women with Kartagener syndrome indicate the importance of uterine and fallopian tube muscular peristalsis.<sup>55</sup> Human fallopian tube muscular contractions are stimulated by prostaglandins  $E_2$  and  $F_{2\alpha}$  and decreased by progestins, human chorionic gonadotropin (hCG), and oxytocin.<sup>56</sup>

Transvaginal endoscopic observation of actual ovum and cumulus oophorus pickup in women revealed that the process is relatively slow (more than 15 minutes), the fimbriae on the ovulating side are distinguished by being erect (probably due to engorged blood vessels and suggesting a local ovarian influence), and the only observable active mechanism involved ciliary movement.<sup>57,58</sup> It is probable, therefore, that in normal circumstances, smooth muscle contractions and the flow of secretory fluid in response to ciliary activity work together to accomplish egg transport.

Secretory epithelium of the tube is actively involved in secretion of a variety of bioactive compounds. Maximal production of tubal fluid is seen in midcycle, and it is believed that its constituents, primarily prostaglandins, play a major role in modulating tubal contractile activity in order to facilitate the ovum pick up and embryo transfer.<sup>59,60</sup> At midcycle, following follicular rupture and ovulation, follicular fluid becomes the major component of the tubal fluid. In addition to the modulatory effects that follicular fluid exerts on ciliary beat frequency and tubal muscular contractility, the simple stream of follicular fluid into the tubal lumen may assist the ovum pick up and transport process.<sup>61</sup>

In most species, transport of the ovum (the fertilized oocyte) through the tube requires approximately 3 days.<sup>62</sup> The time spent within the various parts of the tube varies from one species to another. Transport through the ampulla is rapid in the rabbit, whereas in women, the egg spends about 80 hours in the tube, 90% of which is in the ampulla at the junction of the ampulla with the isthmus. It is in this location that fertilization and dispersion of the cumulus cells are completed.

Attempts to modify tubal function as a method for understanding its physiology have involved three major pharmacologic approaches: **(1)** altering levels of steroid hormones, **(2)** interference with or supplementation of adrenergic stimuli, and **(3)** treatment with prostaglandins. Although there is abundant literature on the effects of estrogen and progesterone on tubal function, it is clouded by the use of different hormones, different doses, and different timing of injections. Because of these variations, it is difficult to obtain a coherent picture and to relate the experimental results to the in vivo situation. In general, pharmacologic doses of estrogen favor retention of eggs in the tube. This “tube-locking” effect of estrogen can be partially reversed by treatment with progesterone (**Figure 6.5**).



**FIGURE 6.5**

The isthmus of the tube has an extensive adrenergic innervation. Surgical denervation of the tube, however, does not disrupt ovum transport. Prostaglandins (PG) of the F series stimulate muscle activity of the tube. Although  $\text{PGF}_{2a}$  stimulates human oviductal motility *in vivo*, it does not cause acceleration of ovum transport.

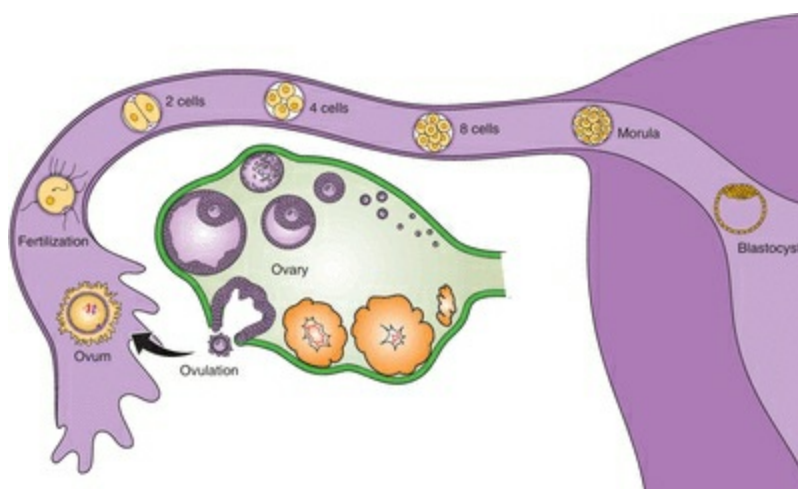
Is there an essential anatomic segment of the tube? Excision of the ampullary-isthmus junction in rabbits does not prevent fertility.<sup>63</sup> This is equally true if small segments of the ampulla are removed, and pregnancy can occur even if the entire isthmus and uterotubal junction are excised. Although the fimbriae are thought to play a crucial role in fertility, spontaneous pregnancies have been reported following sterilization by fimbriectomy or following surgical repair of tubes whose fimbriated ends had been excised.<sup>64,65</sup> The fallopian tube appears to readily adapt to anatomic changes and restrictions.

In most species, a period of residence in the tube appears to be a prerequisite for full development. Rabbit eggs can be fertilized in the uterus, but they do not develop unless transferred to the tubes within 3 hours of fertilization.<sup>66</sup> This implies that there may be a component in uterine fluid during the first 48 hours following ovulation that is toxic to the egg.<sup>66</sup> Indirect evidence of an inhospitable environment is also provided by studies indicating that there must be synchrony between development of the endometrium and the egg for successful pregnancy to occur.<sup>67,68</sup> If the endometrium is in a reduced or advanced stage of development compared with the egg, fertility is compromised. In addition, the blastocyst must undergo cleavage and development in order to gain the capability to implant in the uterus. **Thus, it is conceptually useful to view the fallopian tube not as an active transport mechanism but as a structure that provides an important holding action. This functional behavior is coordinated by the increasing estrogen and progesterone levels after ovulation, although local**

## embryonic signals may also be involved.

Successful pregnancies have occurred in the human following the Estes procedure, in which the ovary is transposed to the uterine cornua.<sup>69</sup> Eggs are ovulated directly into the uterus, completely bypassing the tube. Moreover, when fertilized donor eggs are transferred to women who are receiving hormone supplementation, there are several days during the treatment cycle when the blastocysts will implant. This crucial difference between animal and human physiology is of more than academic importance. There has been speculation about the use of drugs that could accelerate tubal transport as a means of providing contraception by ensuring that the egg would reach the uterus when it was in an unreceptive state. Although this may work in animals, it is of doubtful value in the human because perfect synchrony is not required.

Animal and human reproduction also differ in the occurrence of ectopic pregnancy. Ectopic pregnancies are rare in animals, and in rodents, they are not induced even if the uterotubal junction is occluded immediately following fertilization. The embryos reach the blastocyst stage and then degenerate (**Figure 6.6**).



**FIGURE 6.6**

## Key Points: Egg Transport

- After ovulation, the oocyte and its surrounding cumulus are in the ampulla of the fallopian tube within 15–20 minutes.
- Tubal transport depends on smooth muscle contractions and ciliary-induced flow of secretory fluid.
- The fallopian tube provides an important holding action to allow time for the endometrium to become receptive and the blastocyst to become capable of

implantation, a time period of approximately 80 hours, 90% of which is in the ampulla.

# OOCYTE MATURATION

---

Oocyte maturation, as reviewed in [Chapter 5](#), is regulated by the gonadotropins, the sex hormones, and the complex interaction among an array of growth factors and cytokines in the follicular fluid. In nonmammalian species, a nongenomic action of progesterone causes an increase in intracellular calcium concentrations. In human oocytes, an influx of extracellular calcium occurs in response to estradiol, followed by secondary rises in calcium ions from intracellular stores, characterized by wave-like oscillations.<sup>70</sup> This is a nongenomic response to estradiol at the cell surface, and the transient increases in intracellular calcium improve the quality of the oocyte and contribute to the capability for fertilization.

Calcium oscillations are a property common to mammalian oocytes and are also an early reaction to the fertilizing spermatozoan.<sup>71</sup> Neither the presence of estradiol nor the calcium oscillations are required for oocytes to resume meiosis. However, improved fertilization following estradiol-induced calcium increases indicates an important role for intrafollicular estradiol in overall oocyte maturation.



# FERTILIZATION

---

The fertilizable life of the human oocyte is unknown, but estimates range between 12 and 24 hours. However, immature human eggs recovered for in vitro fertilization can be fertilized even after 36 hours of incubation. Equally uncertain is knowledge of the fertilizable lifespan of human sperm. The most common estimate is 48–72 hours, although motility can be maintained after the sperm have lost the ability to fertilize. The extreme intervals that have achieved pregnancy documented after a single act of coitus are 6 days prior to and 3 days after ovulation.<sup>72</sup> The great majority of pregnancies occur when coitus takes place within the 3-day interval just prior to ovulation.<sup>73</sup>

Contact of sperm with the egg, which occurs in the ampulla of the tube, may not be random; there is some evidence for sperm-egg communication that attracts sperm to the oocyte.<sup>74,75,76</sup> This chemotactic responsiveness of sperm requires the changes that take place in the capacitation process.<sup>77</sup> Thus, this may be a system to select a sperm that is fully capable of fertilization.

The cumulus oophorus undergoes a preovulatory expansion that has at least two important roles. The ampullary space of the human fallopian tube is relatively large (compared with the oocyte), and the expanded cumulus may serve to increase the chances of an encounter with one of the few spermatozoa that have reached the far section of the tube. In addition, this change may facilitate sperm passage through the cumulus. Sperm pass through the cumulus without the release of acrosomal enzymes.<sup>78</sup> It has been suggested, based on in vitro experiments, that the cumulus is essential for full development of the fertilizing ability of sperm; however, removal of the cumulus does not prevent sperm penetration and fertilization.

Despite the evolution from external to internal fertilization over a period of about 100 million years, many of the mechanisms have remained the same.<sup>79,80,81</sup> The acellular zona pellucida that surrounds the egg at ovulation and remains in place until implantation has two major functions in the fertilization process:

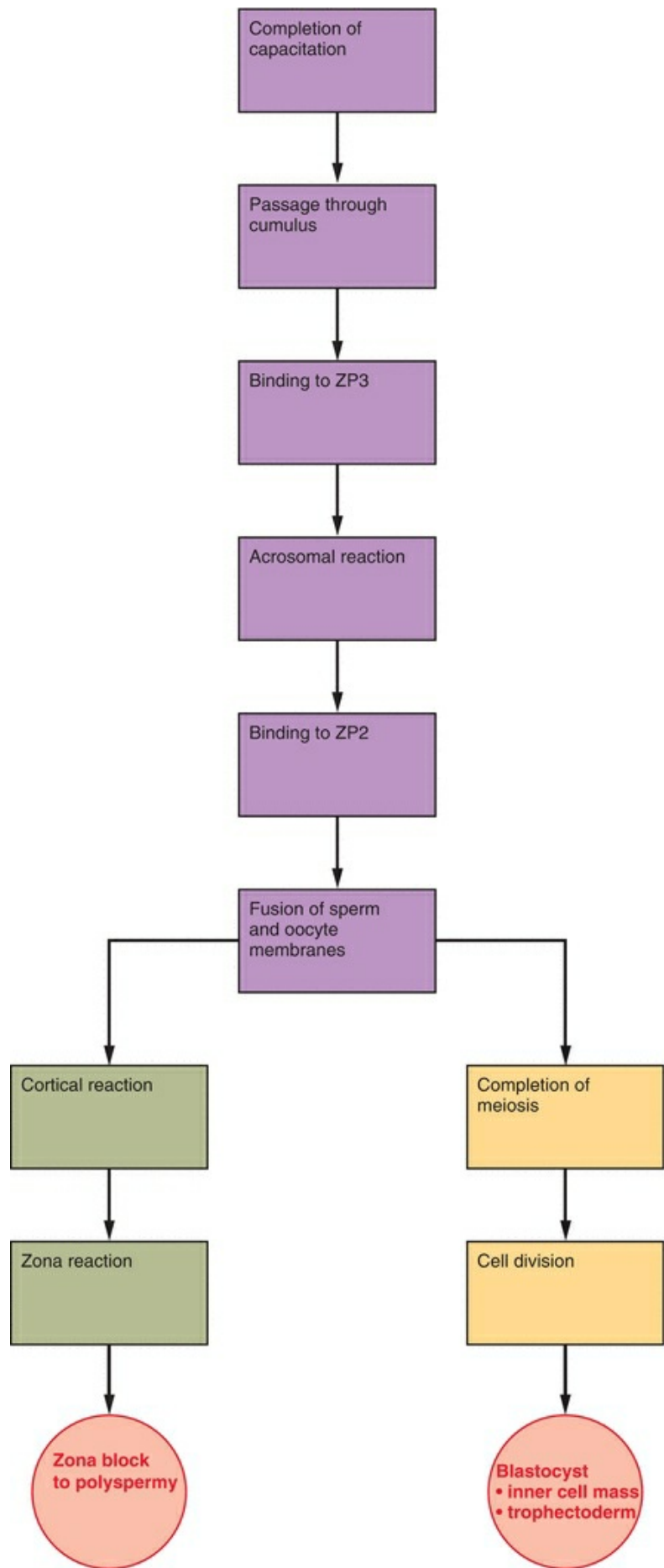
1. The zona pellucida contains ligands for sperm, which are, with some exceptions, relatively species specific.
2. The zona pellucida undergoes the **zona reaction** in which the zona becomes impervious to other sperm once the fertilizing sperm penetrates, and thus, it provides a bar to polyploidy.<sup>82</sup>

Sperm bind to the zona pellucida for about a minute and then penetrate it rapidly, mediated by acrosin, a trypsin-like proteinase that is bound to the inner acrosomal membrane of the sperm.<sup>81,83,84</sup> The pivotal role assigned to acrosin has been disputed.

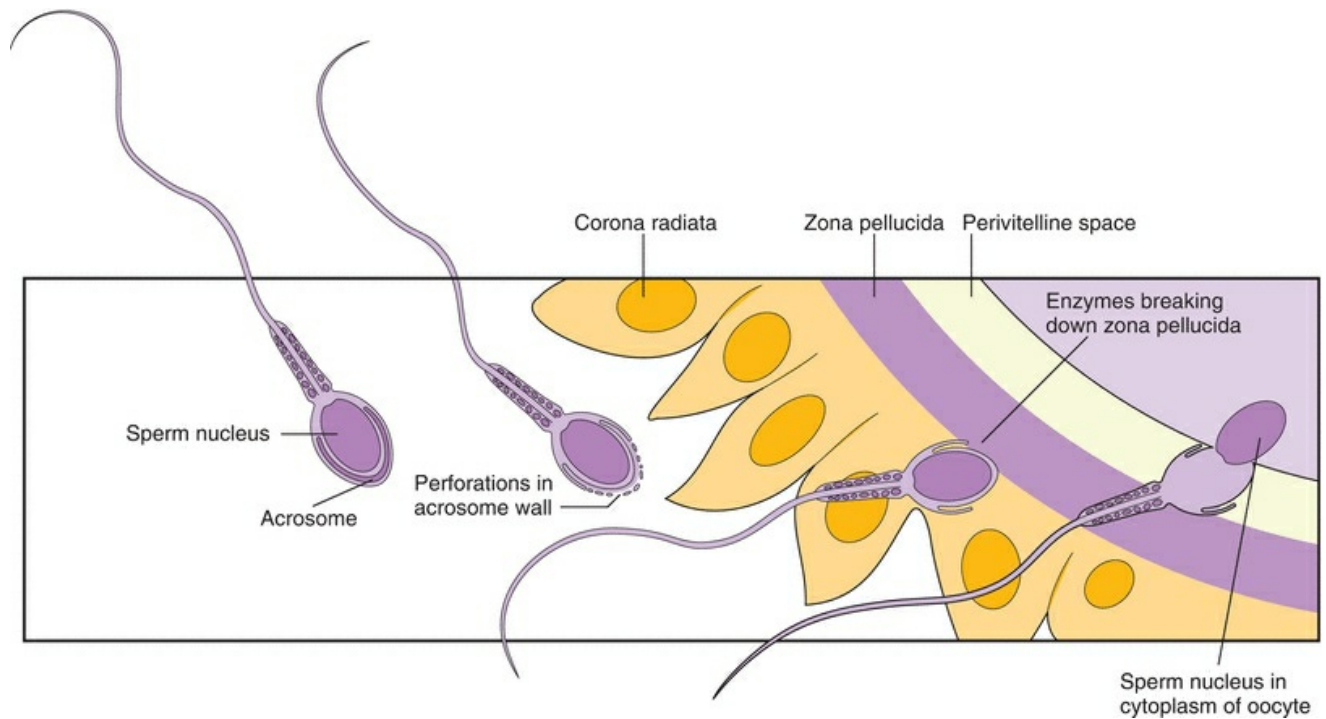
For example, manipulations that increase the resistance of the zona to acrosin do not interfere with sperm penetration, and thus, sperm motility may be the critical factor. The zona pellucida is a porous structure due to the many glycoproteins assembled into long, interconnecting filaments. Nevertheless, a preponderance of evidence favors tenacious binding of capacitated spermatozoa to the zona pellucida as a requirement for penetration, although it is clear that penetration requires physical thrust with active motility not only of the tail but of the head as well. Indeed, sperm undergo rapid lateral oscillations of the head about a fulcrum at the head-tail junction, suggesting a scythe-like action on the zona.<sup>2,81</sup>

The acrosome is a lysosome-like organelle in the anterior region of the sperm head, lying just beneath the plasma membrane like a cap over the nucleus. The lower part of the two arms is called the equatorial segment. The acrosome contains many enzymes that are exposed by the **acrosome reaction, immediately before fertilization. This reaction is one of exocytosis, the fusion of an intracellular storage vesicle with the inner surface of the cell membrane, followed by release of the vesicle contents.** The acrosome reaction requires an influx of calcium ions, the efflux of hydrogen ions, an increase in pH, and fusion of the plasma membrane with the outer acrosomal membrane, leading to the exposure and escape of the enzymes contained on the inner acrosomal membrane. Binding to the zona pellucida is required to permit a component of the zona to induce the acrosomal reaction. This component is believed to be a glycoprotein sperm receptor, which thus serves dual functions: binding of sperm and induction of the acrosomal reaction.

The initial contact between the sperm and the oocyte is a receptor-mediated process. The zona pellucida is composed of glycoproteins secreted by the oocyte, known as ZP1, ZP2, ZP3, and ZP4, with ZP3 being the most abundant.<sup>85,86,87,88</sup> In humans, ZP3 and ZP4 are the primary ligands for sperm and ZP2 binding occurs after the acrosome reaction, participating in the zona reaction to prevent polyspermy.<sup>89</sup> Structural alteration of these glycoproteins leads to a loss of activity; inactivation of these ligands after fertilization is probably accomplished by one or more cortical granule enzymes. The ZP gene is expressed only in growing oocytes. DNA sequence similarities of the ZP3 gene in various mammals indicate that this gene has been evolutionarily conserved and that the sperm-ligand interaction is a common mechanism among mammals (**Figures 6.7 and 6.8**).<sup>90</sup> Mice with a disrupted ZP3 gene produce oocytes lacking a zona pellucida and are unable to become pregnant.<sup>91,92</sup> A vaccine against zona pellucida glycoproteins from pigs is used to control reproduction in a variety of female animals, including female elephants and deer.<sup>93</sup> Human use of such a vaccine has been hampered by the difficulty in preparing pure glycoproteins, but this is now possible using recombinant techniques.<sup>94</sup>



**FIGURE 6.7**



**FIGURE 6.8**

The initial binding of the sperm to the zona requires recognition on the part of the sperm of the carbohydrate component of the species-specific glycoprotein ligand molecule.<sup>88,95</sup> Once binding is accomplished, the acrosome reaction is triggered by the peptide chain component of the receptor glycoprotein. At least one receptor on the sperm head is a tyrosine kinase that is activated by binding to the ZP3 glycoprotein and is an initiator of the acrosome reaction.<sup>96,97</sup> This interaction is analogous to the general principle of behavior for hormone-receptor binding and activity. In the case of sperm and oocyte, recognition of the oocyte zona ligand involves an enzyme on the surface of the sperm that becomes exposed during capacitation. Formation of the ZP3-enzyme complex, therefore, not only produces binding but also induces the acrosome reaction. The G-protein signaling system is present on sperm heads, and activation at this point in time by progesterone, in an extragenomic mechanism, opens calcium channels to increase intracellular levels of calcium ions, a requirement for the acrosome reaction.<sup>98,99,100</sup> Thus, the initial sperm-zona interaction depends on binding of acrosome-intact spermatozoa, followed by a process mediated by the enzymes released by the zona-induced acrosome reaction. Protein kinase C activation is an important step in the acrosomal reaction, leading to phosphorylation of sperm proteins involved in the

process.<sup>101,102</sup>

Glycodelin is a glycoprotein with many isoforms found in endometrium, the fallopian tubes, follicular fluid, and in seminal fluid. The various forms of glycodelin modulate sperm function and fertilization by maintaining sperm in the uncapacitated state and inhibiting binding of sperm to the zona pellucida by competing for zona receptors. A specific receptor for glycodelin is present on sperm, and thus, it makes sense that down-regulation of glycodelin expression would be associated with the hormonal changes at ovulation coinciding with the opening of the fertilization window.<sup>103</sup>

Spermatozoa enter the perivitelline space at an angle. The oocyte is a spherical cell covered with microvilli. The sperm head is like a flat dish, and the thickness of the head is a little less than the distance between the oocyte microvilli.<sup>104</sup> The region of the equatorial segment of the sperm head, the distal portion of the acrosome, makes initial contact with the vitelline membrane (the egg plasma membrane or oolemma). At first, the egg membrane engulfs the sperm head, and, subsequently, there is fusion of egg and sperm membranes. Bedford has opined that the tangential trajectory of this process allows closure with expansion of the blastocyst, preventing the persistence of a hole that would allow herniation or interfere with the normal hatching that occurs later within the uterus.<sup>105</sup>

Sperm-egg fusion is mediated by specific proteins. Two membrane proteins from the sperm head have been sequenced; one (PH-20, also called SPAM1) is involved in binding to the zona pellucida, and the other (PH-30, also called fertilin) is involved in fusion with the oocyte.<sup>106,107</sup> PH-20, with hyaluronidase activity, is also active in dispelling the cumulus.<sup>108</sup> The cell membrane of the unfertilized oocyte contains integrin adhesion/fusion molecules that recognize peptides such as fibronectin, laminin, and collagen.<sup>109</sup> Fibronectin appears on the spermatozoa, but it is disputed whether it appears with caudal maturation or after capacitation. Vitronectin is a sperm protein that is activated after capacitation and the acrosome reaction and may be the key peptide interacting with oocyte cell membrane integrins.<sup>110</sup> These steps in the fusion process will occur only with sperm that have undergone the acrosome reaction. Multiple sperm-associated surface proteins are involved in binding to the oocyte membrane, but no single peptide has been identified as absolutely essential for fertilization, implying redundancy.<sup>111,112</sup>

Fusion of the sperm and oocyte membrane to form a zygote is followed by the cortical reaction and metabolic activation of the oocyte. An increase in intracellular-free calcium in a periodic, oscillatory pattern always precedes the cortical reaction and oocyte activation at fertilization, and this is believed to be the mechanism by which the

spermatozoon triggers these developmental events.<sup>71,113,114</sup> It is believed that calcium signaling in fertilization is initiated by the introduction of a sperm factor into the egg, a phospholipase protein that activates inositol 1,4,5-trisphosphate leading to calcium release.<sup>114</sup> An analysis of failed fertilizations in one couple after ICSIs indicated a high prevalence of failed oocyte activation; repeated ICSI after initiating oocyte activation with a calcium ionophore resulted in a successful pregnancy.<sup>115</sup>

The initiation of the block to penetration of the zona by other sperm is mediated by the **cortical reaction**, another example of exocytosis with the release of materials from the **cortical granules**, lysosome-like organelles that are found just below the egg surface.<sup>116</sup> As with other lysosome-like organelles, these materials include various hydrolytic enzymes. Changes brought about by these enzymes lead to the **zona reaction, the hardening of the extracellular layer by cross-linking of structural proteins, and inactivation of ligands for sperm receptors.**<sup>117</sup> Thus, the zona block to polyspermy is accomplished. The initial change in this zona block is a rapid depolarization of the oocyte membrane associated with a release of calcium ions from calmodulin.<sup>118,119</sup> The increase in intracellular calcium acts as a signal or trigger to activate protein synthesis in the oocyte. The depolarization of the membrane initiates only a transient block to sperm entry. The permanent block is a consequence of the cortical reaction and the release of enzymes, also apparently triggered by the increase in calcium.

Approximately 3 hours after fertilization, meiosis is completed.<sup>120</sup> The second polar body is released, leaving the egg with a haploid complement of chromosomes. The addition of chromosomes from the sperm restores the diploid number to the now fertilized egg. The chromatin material of the sperm head decondenses, and the male pronucleus is formed. The male and the female pronuclei migrate toward each other, and as they move into close proximity, the limiting membranes break down, and a spindle is formed on which the chromosomes become arranged. Thus, the stage is set for the first cell division.

Embryonic genome activity in the human begins early; DNA synthesis activity can be detected 9–10 hours after insemination.<sup>121</sup> Human gene expression (transcription) begins between the 4- and 8-cell stages of preimplantation cleavage, 2–3 days after fertilization.<sup>122</sup> Earlier embryonic signals may be derived from a store of maternal messenger RNAs, termed the “maternal legacy.”<sup>123,124</sup> In addition, proteomics have identified RNAs and transcription factors within sperm that suggest a mechanism for a paternal contribution to the early development of the embryo.<sup>35,125</sup>

Clinicians are interested not only in how normal fertilization takes place but also in the occurrence of abnormal events that can interfere with pregnancy. It is worthwhile, therefore, to consider the failures that occur in association with in vivo fertilization.

Studies in the nonhuman primate have involved monkeys and baboons. A surgical method was used to flush the uterus of regularly cycling rhesus monkeys, and 9 preimplantation embryos and 2 unfertilized eggs were recovered from 22 flushes. Two of the nine embryos were morphologically abnormal and probably would not have implanted.<sup>126</sup> Hendrickx and Kraemer used a similar technique in the baboon and recovered 23 embryos, of which 10 were morphologically abnormal.<sup>127</sup> This suggests that, in nonhuman primates, some ovulated eggs are not fertilized and that many early embryos are abnormal and, in all likelihood, will be aborted. Similar findings have been reported in the human in the classic study of Hertig et al.<sup>128</sup> They examined 34 early embryos recovered by flushing, and examination of reproductive organs removed at surgery. Ten of these embryos were morphologically abnormal, including 4 of the 8 preimplantation embryos. Because the 4 preimplantation losses would not have been recognized clinically, there would have been 6 losses recorded in the remaining 30 pregnancies.

In each ovulatory cycle, only 20–30% of normally fertile couples can achieve a pregnancy.<sup>129</sup> By using sensitive pregnancy tests, it has been suggested that 20% of pregnancies are lost after implantation and before the pregnancy is clinically perceived.<sup>130,131</sup> In the postimplantation period, if only clinically diagnosed pregnancies are considered, the generally accepted figure for spontaneous miscarriage in the first trimester in young women is 15%. Approximately 50–60% of these abortuses have chromosome abnormalities.<sup>132</sup> This suggests that a minimum of 7.5% of all human conceptions are chromosomally abnormal. The fact that only 1 in 200 newborns has a chromosome abnormality attests to the powerful selection mechanisms operating in early human gestation.

## Key Points: Fertilization

- Sperm penetration of the zona pellucida depends on a combination of sperm motility, an acrosomal proteinase, and binding of sperm head receptors to zona ligands.
- Binding of sperm head receptors and zona ligands produces an enzyme complex that induces the acrosome reaction, releasing enzymes essential for the fusion of the sperm and oocyte membranes.
- Fusion of the sperm and oocyte membranes triggers the cortical reaction, the release of substances from the cortical granules, organelles just below the egg cell membrane.
- The cortical reaction leads to the enzyme-induced zona reaction, the hardening of the zona, and the inactivation of ligands for sperm receptors, producing an

obstacle to polyspermy.

- Cell division begins promptly after fertilization; human embryonic gene expression begins between the 4- and 8-cell stages.



# IMPLANTATION AND PLACENTATION

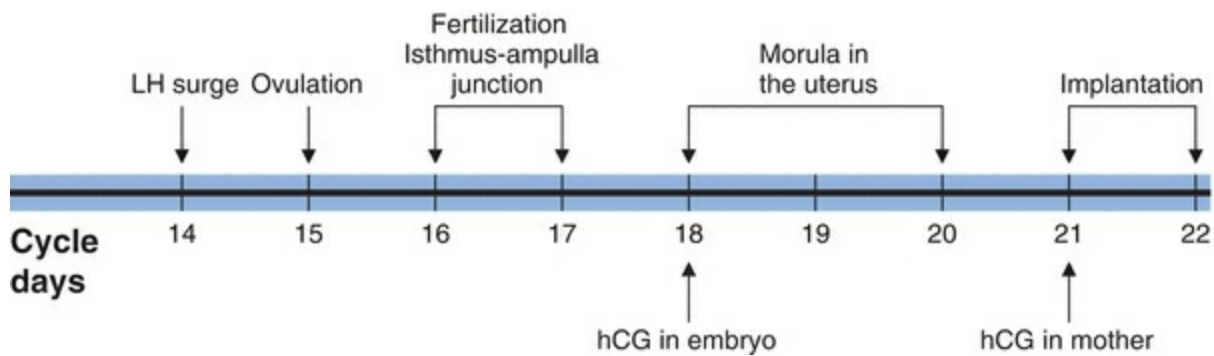
---

A normal pregnancy is, of course, impossible without successful implantation and placentation. Because there are differences among the various species, we will focus on the physical and biochemical events that are relevant in human reproduction.<sup>133,134</sup> Shortly after the 8-cell morula enters the uterine cavity about 4 days after the gonadotropin surge and 3 days after ovulation, a blastocyst (a preimplantation embryo of varying cell number, from 32 to 256) is formed. Implantation (the embedding of the blastocyst in the endometrial stroma) begins with the loss of the zona pellucida (hatching) about 1–3 days after the morula enters the uterine cavity.

# Preparation for Implantation

The change from proliferative to secretory endometrium, described in detail in [Chapter 3](#), is an essential part of achieving the receptive conditions required for implantation. The primary endocrine requirement is the presence of progesterone; in the monkey, implantation and pregnancy can be achieved in the absence of luteal phase estrogen.<sup>135</sup> **This crucial histologic change is termed decidualization, the process of endometrial fibroblasts transforming into specialized secretory decidual cells, and is caused by many underlying biochemical and molecular events orchestrated by progesterone.** In most species, the implanting embryo triggers the decidualization process. In human beings, however, decidualization is under maternal control and initiated during the mid-secretory phase of each cycle in response to elevated progesterone and rising cellular cAMP levels. The human endometrium is 10–14 mm thick at the time of implantation in the midluteal phase. By this time, secretory activity has reached a peak, and the endometrial cells are rich in glycogen and lipids. Decidualization is indispensable for pregnancy as it confers immune tolerance to the developing fetal semi-allograft, regulates trophoblast invasion, and both nourishes and protects the peri-implantation conceptus against a variety of physiologic stressors associated with pregnancy.<sup>136</sup> Indeed, nourishment of the human fetus is dependent on contributions from the endometrial glands until the end of the first trimester of pregnancy, when a high level of maternal blood flow is reached within the placenta.<sup>137</sup>

Understanding the dynamic endocrine behavior of the endometrium ([Chapter 3](#)) increases the appreciation for its active participation in the implantation process. The window of endometrial receptivity is restricted to days 16–22 of a 28-day normal cycle (5–10 days after the LH surge) and days 16–19 of cycles stimulated by exogenous gonadotropins.<sup>68,138,139,140</sup> The harmonious synchronization of a large cast of biochemical and molecular players is a complex achievement required for normal implantation. It is not surprising that gene expression studies have begun to identify the presence of dysregulated endometrial genes in women with repeated implantation failures.<sup>141</sup> The maximal chance of a normal implantation is only about 40% per cycle under optimal conditions<sup>142</sup> ([Figure 6.9](#)).



**FIGURE 6.9**

Endometrial receptivity is heralded by the progesterone-induced formation of **pinopodes (also called uterodomes)**, surface epithelial cells that lose their microvilli and develop smooth protrusions, appearing and regressing during the window of receptivity.<sup>143</sup> The pinopodes may serve to absorb fluid from the uterine cavity forcing the blastocyst to be in contact with the endometrial epithelium. Blastocysts adhere at sites with pinopodes where the cell surface loses its nonadhesive character.<sup>144</sup> The most critical feature of the pinopode is the removal of adhesion-inhibiting mucin during the window of implantation.<sup>145</sup> Pinopodes appear around day 21 and are present only for a few days during implantation, following the peak in progesterone levels and marked by a decrease in progesterone receptor B in the endometrium.<sup>146</sup> However, this limited appearance of pinopodes is controversial as others have described their appearance throughout the luteal phase and into pregnancy.<sup>147</sup>

While it has been known for long time that progesterone exerts a profound influence on uterine function during early gestation and is crucial for implantation, our understanding of the underlying molecular mechanisms mediated by progesterone action have grown substantially over the past decade by detailed molecular studies in genetically engineered mouse models. These studies have revealed that several progesterone-regulated pathways involved in endometrial function during implantation are conserved in mice and humans. Several progesterone receptor-regulated genes such as *Ihh*, *Bmp2*, *Wnt4*, *Hoxa10*, and *Hand2* are essential for implantation and decidualization.<sup>148,149</sup>

Even before the blastocyst adheres to the surface epithelium, but after hatching from the zona pellucida, a dialogue between the mother and the early embryo has begun. Early pregnancy factor (EPF) can be detected in the maternal circulation within 1–2 days after fertilization.<sup>150</sup> Prior to implantation, EPF is apparently produced by the ovary in response to a signal from the embryo. After implantation, EPF is no longer secreted by the ovary but is derived from the embryo. EPF has immunosuppressive

properties and is associated with cell proliferation and growth. Indeed, there is reason to believe that endometrial receptivity for implantation requires appropriate signals from the embryo. One such signal is hCG.

Blastocysts grown in culture produce and secrete hCG, beginning days 7–8 after fertilization.<sup>151</sup> Messenger RNA for hCG can be found in 6- to 8-cell human embryos.<sup>152</sup> Because the 8- to 16-cell stage is achieved about 3 days after fertilization, it is believed that the human embryo begins to produce hCG before implantation when it can be detected in the mother (about 6–7 days after ovulation). The embryo is capable, therefore, of preimplantation signaling, and higher levels of estradiol and progesterone can be measured in the maternal circulation even before maternal hCG is detectable, presumably because of stimulation of the corpus luteum by hCG delivered directly from the uterine cavity to the ovary.<sup>153</sup> Function of the corpus luteum is crucial during the first 7–9 weeks of pregnancy, and luteectomy early in pregnancy can precipitate abortion.<sup>154</sup> Similarly, early pregnancy loss in primates can be induced by injections of anti-hCG serum.<sup>155</sup> Another substance secreted very early by the preimplantation embryo is platelet-activating factor, perhaps part of the immunosuppressive activity required to induce maternal tolerance of the embryo. In the rabbit, platelet-activating factor also induces the production of EPF.<sup>156</sup> Indeed, many growth factors are produced by the early embryo.<sup>157</sup>

In rodents and rabbits, implantation can be interrupted by injection of prostaglandin inhibitors.<sup>158,159</sup> Indomethacin prevents the increase in endometrial vascular permeability normally seen just prior to implantation. Additional evidence for a role by prostaglandins in the earliest stages of implantation is the finding of increased concentrations of prostaglandins at implantation sites, similar to any inflammatory response.<sup>160</sup> The blastocysts of mice, rabbits, sheep, and cows produce prostaglandins, and prostaglandin E<sub>2</sub> release from human blastocysts and embryos has been demonstrated.<sup>161</sup>

The secretory endometrial epithelial cells are also a source of prostaglandin E<sub>2</sub> (but not prostaglandin F<sub>2α</sub>), and its synthesis may be stimulated by the tissue response that accompanies implantation. However, decidual synthesis of prostaglandins is significantly reduced compared with proliferative and secretory endometrium, apparently a direct effect of progesterone activity and perhaps a requirement in order to maintain the pregnancy.<sup>160</sup> Nevertheless, prostaglandin E<sub>2</sub> synthesis is increased at the implantation site, perhaps in response to blastocyst factors, for example, platelet-activating factor, and correlates with an increase in vascular permeability.<sup>160,162</sup> It is now well accepted that decidua-derived prostaglandin E<sub>2</sub> is one of the major regulators

of trophoblastic invasion, activating other signaling proteins.<sup>163</sup>

As discussed in [Chapter 3](#), the many cytokines, peptides, and lipids secreted by the endometrium are interrelated through the stimulating and inhibiting actions of estrogen and progesterone, as well as the autocrine/paracrine activities of these substances on each other. The response to implantation certainly involves the many members of the growth factor and cytokine families.

Angiogenesis, the growth of blood vessels from preexisting vessels, is a key feature of the endometrial cycle and implantation. This process is regulated indirectly by the sex steroids and directly by growth factors, especially members of the fibroblast growth factor family, the angiopoietins, and the vascular endothelial cell growth factor (VEGF) family. There are at least five VEGF isoforms and four receptors. Two angiopoietins, Ang-1 and Ang-2, share a common tyrosine kinase receptor, Tie2. VEGF-A seems critical for vascular growth and is up-regulated in the presence of reduced oxygen. The angiopoietins also promote the growth of blood vessels and act synergistically with VEGF. Controlled growth as well as appropriate regression reflect the balance between an ever-increasing number of stimulatory and inhibitory factors discovered by scientists in this field ([Table 6.1](#)).<sup>164,165</sup>

## **TABLE 6.1 Growth Factors**

<b>Lipids</b>	<b>Cytokines</b>	<b>Growth Factors</b>
Prostaglandins	Interleukin-1 $\alpha$	Epidermal growth factor family
Thromboxanes	Interleukin-1 $\beta$	EGF
	Interleukin-6	Heparin-binding EGF
	Interleukin-11	TGF- $\alpha$
	Colony-stimulating factor-1	Insulin-like growth factor family
	Tumor necrosis factor- $\alpha$	IGF-I
	Leukemia-inhibiting factor	IGF-II
	Interferon- $\gamma$	IGFBPs 1–6
		Platelet-derived growth factor
		Transforming growth factor- $\beta$
		Fibroblast growth factors
		Vascular endothelial growth factors
		Angiopoietins



# Implantation

**Implantation is defined as the process by which an embryo attaches to the uterine wall and penetrates first the epithelium and then the circulatory system of the mother to form the placenta.** The embryo completely invades the endometrium only in great apes and humans. Implantation is a process that is limited in both time and space, beginning 2–3 days after the fertilized egg enters the uterus usually on day 18 or 19 of the cycle (3 or 4 days after ovulation).<sup>140</sup> Thus, implantation occurs 5–7 days after fertilization. A careful study of women attempting to conceive documented that the first hormonal evidence of implantation (the appearance of hCG) occurred on 8, 9, or 10 days after ovulation; the earliest was 6 days and the latest 12 days.<sup>166</sup> The risk of spontaneous early miscarriage markedly increases with late implantations (later than 9 days after ovulation). Implantation consists of three stages: apposition, adhesion, and invasion (also called migration to denote its benign nature).

## Apposition and Adhesion

The human blastocyst remains in the uterine secretions for approximately 1–3 days and then hatches from its zona pellucida in preparation for attachment. The implantation site in the human uterus is usually in the upper, posterior wall in the midsagittal plane. Implantation is marked initially by apposition of the blastocyst to the uterine epithelium, usually about 2–4 days after the morula enters the uterine cavity. A prerequisite for this contact is a loss of the zona pellucida, which, *in vitro*, can be ruptured by contractions and expansions of the blastocyst. *In vivo*, this activity is less critical, because the zona can be lysed by components of the uterine fluid. Nevertheless, blastocyst movement and escape from the zona pellucida appear to involve cytoplasmic projections (this leads to penetrations of the zona by the trophoctoderm prior to zona hatching).<sup>167</sup> By this time, the blastocyst has differentiated into an inner cell mass (embryo) and trophoctoderm (placenta), both essential for implantation.

The endometrium produces at least three cytokines involved in implantation.<sup>168</sup> These are colony-stimulating factor-1 (CSF-1), leukemia-inhibitory factor (LIF), and interleukin-1 (IL-1). CSF-1 expression and receptors for CSF-1 are found in both the human endometrium (peaking in decidua) and the preimplantation embryo. Mice with an inactivating mutation in the CSF-1 gene are infertile because of low rates of implantation and fetal viability.<sup>169</sup> LIF displays the same pattern of expression as CSF-1, and mice with an LIF gene mutation have a failure of blastocyst implantation.<sup>170,171</sup> Blocking the interleukin-1 receptor in mice also prevents implantation.<sup>168</sup> Interleukin-1 stimulates hCG release from human trophoblast cells, and the endometrium increases VEGF expression and regulates the tissue inhibitors of metalloproteinases (TIMPs);



GnRH is produced in the human blastocyst and stimulates endometrial expression of interleukin-1.<sup>172</sup> Perhaps the first maternal change in the implantation process, increased permeability of the capillaries near the adherent blastocyst, is due to a blastocyst-directed change in heparin-binding epidermal growth factor (HB-EGF) expression in the surface epithelium.<sup>173</sup> In addition, the blastocyst contains receptors for epidermal growth factor that respond to HB-EGF and promote growth and zona hatching.

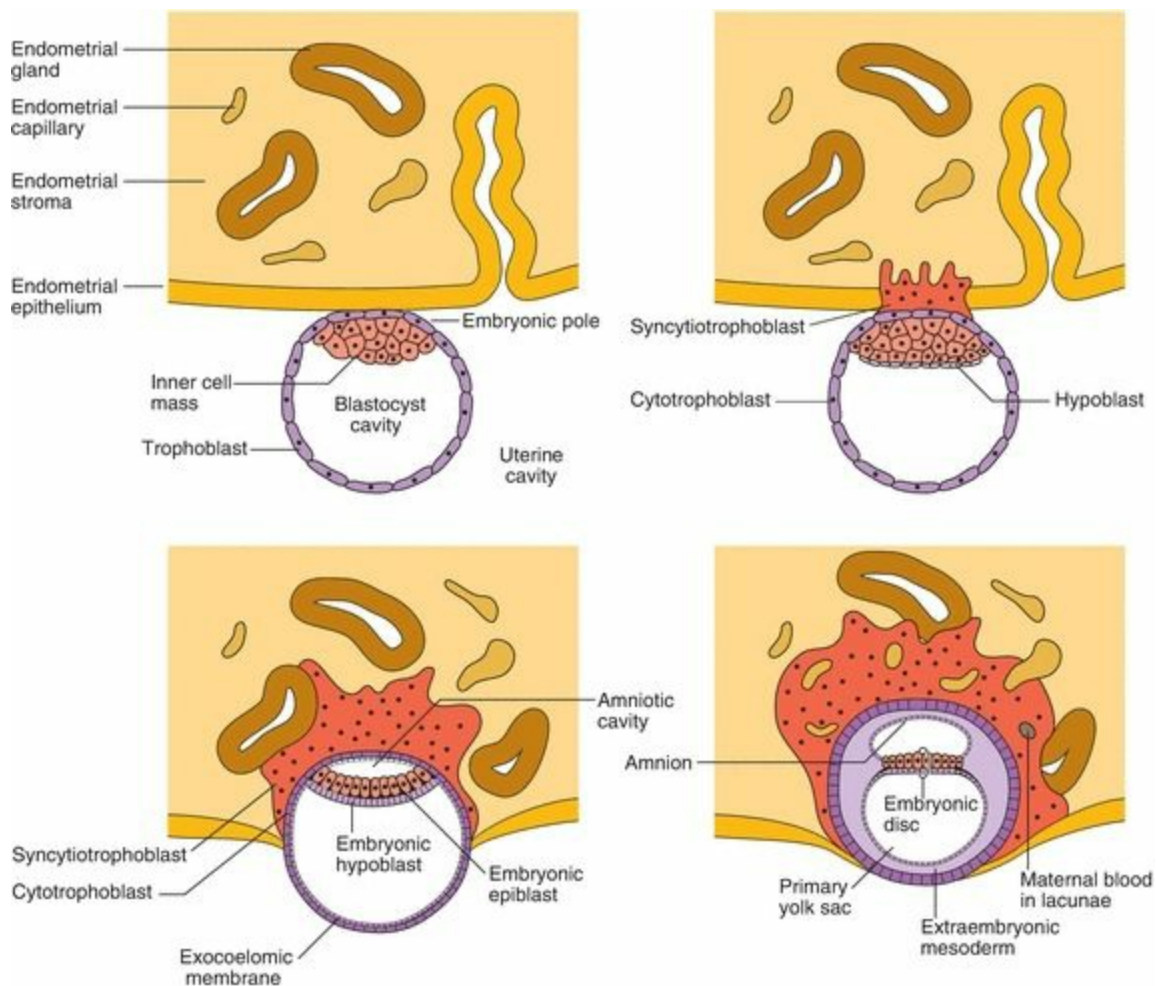
The adhesion process further involves a collection of adhesion molecules, including integrins, selectins, and trophinin.<sup>174</sup> The decidualized endometrium and the early embryo express extracellular matrix components, especially laminin and fibronectin, which mediate cell adhesion by binding to the adhesion molecules.<sup>175</sup> Cells are fixed and supported by the extracellular matrix components such as laminin and fibronectin through attachments to these components via cell surface receptors, especially the integrins. An increase in specific isoforms of laminin in decidua at the time of implantation suggests an important interaction with the invading trophoblast.<sup>176</sup> Thus, implantation starts with adhesion due to binding with endometrial proteins, followed by invasion (migration) of the trophoblast by proteinase degradation of the extracellular matrix.

Integrins are members of a family of transmembrane cell surface receptors for collagen, fibronectin, and laminin. Integrins are utilized in cell-cell and cell-matrix interactions, contributing to cell migration, cell differentiation, and tissue structure. A cyclic change in integrin expression in the endometrial epithelial cells indicates peak expression at the time of implantation.<sup>177</sup> It has been suggested that a lack of integrin expression during the implantation window can be a cause of infertility.<sup>178</sup> The blastocyst also expresses integrins in a time sequence and at a site (outgrowing trophoblast cells) that are appropriate for key activity during implantation.<sup>179</sup> The integrins are a diverse collection of receptors, reflecting various combinations of the  $\alpha$  and  $\beta$  subunits in the structure of the receptor, as well as variations in the cytoplasmic domain in the subunits. Stimulation and inhibition of cellular proliferation in the endometrium and decidua are influenced by specific expression of the appropriate subunits.<sup>180</sup> Mechanisms that control variation in the structure through splicing would account for the expression of an integrin variant appropriate for proliferation early in the endometrial cycle and prevention of proliferation in the decidua, and perhaps prevention of trophoblastic invasion.

Ephrins are peptides that bind to tyrosine kinase cell membrane receptors. Ephrin expression can be detected in both endometrial epithelial cells and in blastocysts.<sup>181</sup> This is another system for the cell-to-cell communication involved in trophoblastic migration.

The process of tissue disruption is accompanied by an increase in lymphocytes, another source for cytokines and growth factors in addition to trophoblast and endometrial cells. The distinction between cytokines and growth factors is not always clear, but T lymphocytes and macrophages are significant secretors of cytokines.

**In general, cytokines, growth factors, and their receptors have been identified in virtually all tissues associated with implantation. The cataloging is lengthy and often confusing.<sup>168,182</sup> It is helpful to simply view these various substances as the biochemical tools by which the physical process of trophoblast adhesion and invasion is accomplished (Figure 6.10).**



**FIGURE 6.10**

Even if the hormonal milieu and protein composition of the uterine fluid are hospitable, implantation may not occur if the embryo is not at the proper stage of development. It has been inferred from this information that there must be developmental maturation of the surface of the embryo before it is capable of attachment and implantation.

Reports of changes in the surface charge of preimplantation embryos differ in their findings, and it is unlikely that changes in surface charge are solely responsible for adherence of the blastocyst to the surface of epithelial cells. Binding of the lectin concanavalin A to the blastocyst changes during the preimplantation period, an indication that the surface glycoproteins of the blastocyst are in transition.<sup>183</sup> It is reasonable to assume that these changes in configuration on the surface occur in order to enhance the ability of the early embryo to adhere to the maternal surface.

As the blastocyst comes into close contact with the endometrium, the microvilli on the surface flatten and interdigitate with those on the luminal surface of the epithelial cells. A stage is reached where the cell membranes are in very close contact and junctional complexes are formed. The early embryo can no longer be dislodged from the surface of the epithelial cells by flushing the uterus with physiologic solutions.

Intense research efforts are undergoing to define the transcriptional profile of the endometrium throughout the menstrual cycle and window of implantation.<sup>184,185</sup> Eventually, the characterization of an endometrium that is normally receptive to implantation will allow medical interventions. It is not far-fetched to consider therapeutic manipulations that will either improve implantation rates or provide contraception.

## **Invasion and Placentation**

In the 2nd week after ovulation, the placenta is formed.<sup>175</sup> By this time, the trophoblasts at the implantation site have formed masses of cytotrophoblasts and syncytiotrophoblasts, and invasion of maternal blood vessels has begun. The walls of the spiral arteries are destroyed, as sinusoidal sacs are formed lined with endovascular trophoblast. The fundamental change is a replacement of maternal vascular cells with cytotrophoblast cells. The purpose of placental invasion is to remodel the uterine vasculature, establishing a structure that will allow and maintain a high blood flow interchange between mother and fetus, replacing small, high-resistance vessels with large, low-resistance vessels. **The invading placental cells are special trophoblast cells, known as the extravillous trophoblast, that arise by proliferation and differentiation of cytotrophoblast stem cells within the chorionic villi.**

Three types of interactions between the implanting trophoblast and the uterine epithelium have been described.<sup>186</sup> First, trophoblast cells intrude between uterine epithelial cells on their path to the basement membrane. In the second type of interaction, the epithelial cells lift off the basement membrane, an action that allows the trophoblast to insinuate itself underneath the epithelium. Last, fusion of the trophoblast with individual uterine epithelial cells has been identified by electron microscopy in the

rabbit.<sup>187</sup> This latter method of gaining entry into the epithelial layer raises interesting questions about the immunologic consequences of mixing embryonic and maternal cytoplasm.

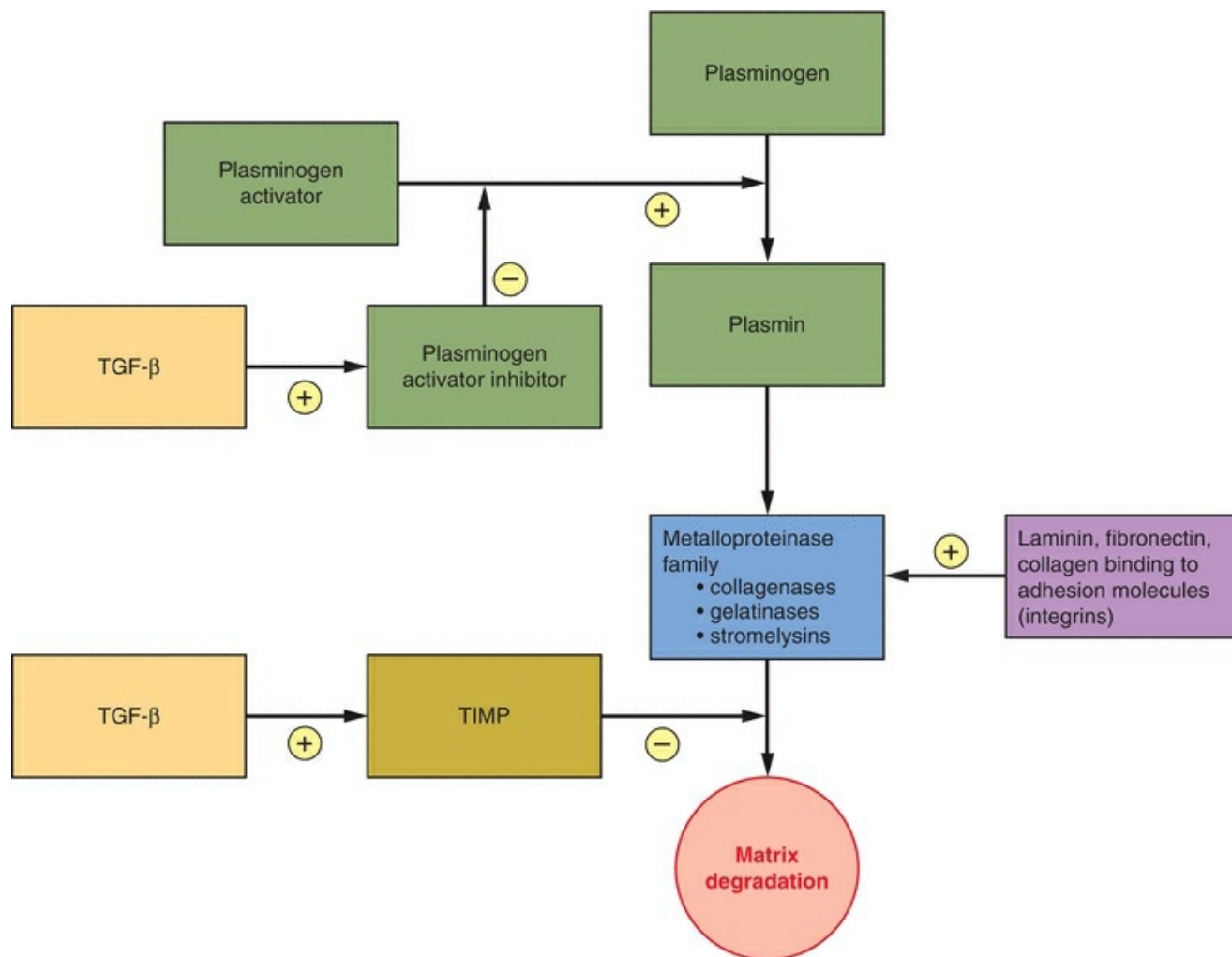
Trophoblast has the ability to phagocytose a variety of cells, but, in vivo, this activity seems largely confined to removal of dead endometrial cells, or cells that have been sloughed from the uterine wall. Similarly, despite the invasive nature of the trophoblast, destruction of maternal cells by enzymes secreted by the embryo does not play a major role in implantation; there is virtually no necrosis. The early embryo does secrete a variety of enzymes (e.g., collagenase and plasminogen activators), and these are important for digesting the intercellular matrix that holds the epithelial cells together. Studies in vitro have demonstrated the presence of plasminogen activator in mouse embryos and in human trophoblast, and its activity is important in the attachment and early outgrowth stages of implantation.<sup>188,189</sup> Urokinase and proteases, trophoblastic enzymes that convert plasminogen to plasmin, are inhibited by hCG, indicating regulation of this process by the embryo.<sup>190</sup>

The trophoblast at a somewhat later stage of implantation can digest, in vitro, a complex matrix composed of glycoproteins, elastin, and collagen, all of which are components of the normal intercellular matrix.<sup>191,192</sup> Studies in vitro indicate that cells move away from trophoblast in a process called “contact inhibition.”<sup>193</sup> Trophoblast then spreads to fill the spaces vacated by the cocultured cells. Once the extracellular matrix has been lysed, this movement of epithelial cells away from trophoblast would allow space for the implanting embryo to move through the epithelial layer. Trophoblast movement is aided by the fact that only parts of its surface are adhesive, and the major portion of the surface is nonadhesive to other cells.

The highly proliferative phase and migration of trophoblastic tissue during early embryogenesis are regulated by the many growth factors and cytokines produced in both fetal and maternal tissues.<sup>194</sup> VEGF is important for the growth of new blood vessels, and the angiopoietins recruit perivascular cells to provide vascular stability. The interaction of VEGF and angiopoietins is important in the remodeling of maternal vessels necessary to develop the uteroplacental circulation. Another signal from the fetus to induce maternal blood vessels to grow is hCG, which of course is available even before implantation to bind to its receptor in the endometrium and stimulate vessels directly as well as the expression of angiogenic factors, such as VEGF.<sup>195,196</sup> Preeclampsia is characterized by insufficient spiral artery remodeling, and it has been suggested that alterations in circulating angiogenic factors play a pathogenic role in preeclampsia. Women with preeclampsia have been shown to have increased levels of the antiangiogenic factors, soluble fms-like tyrosine kinase 1 (sFlt-1), and soluble endoglin (sEng), which are thought to trap circulating VEGF, placental growth factor

(PGF), and transforming growth factor  $\beta$  (TGF $\beta$ ), respectively, decreasing their free levels, leading to endothelial dysfunction and the clinical manifestations of the disease.<sup>197,198</sup>

Invasion of the early trophoblast requires the expression of integrins, stimulated by trophoblast-derived insulin-like growth factor-II and decidua-derived IGF-binding protein-1, and inhibited by decidua-derived TGF $\beta$  (**Figure 6.11**).<sup>199,200</sup> Actively migrating trophoblast cells have a different integrin profile than nonmigrating cells, specifically cell surface receptors that preferentially bind laminin.<sup>175,201</sup> The controlling mechanism (not yet known) for this change in integrin expression must be a key regulator of trophoblast invasion. The specific nature of integrin expression can determine binding to matrix components, a requirement for migration.



**FIGURE 6.11**

Integrin cell surface binding for the matrix components can be also regulated by

activating and inactivating the integrins. This would allow trophoblast cells to alternate between adhesive and nonadhesive states, thus achieving directional cell migration.<sup>202</sup> The role of integrin cell surface receptors is not simply to bind to a structural component in extracellular matrix but also to activate intracellular signaling pathways (similar to the classic endocrine tropic hormone-cell membrane receptor pathway) that result in activation of enzymes that ultimately promote adhesion and to regulate cellular gene transcription.<sup>175</sup> IGF-binding protein-1 can stimulate trophoblastic cell migration independently of the IGF system by binding to an integrin receptor and activating kinase pathways.<sup>203</sup>

The uterine spiral arterioles are invaded by cytotrophoblasts, and the maternal endothelium is replaced by cytotrophoblast tissue as far as the first third of the myometrium. The maternal vascular invasion by trophoblast cells and replacement of vascular endothelium with endovascular trophoblast may utilize a different class of surface molecules, the selectin family.<sup>175</sup> The selectins have been demonstrated to be present in decidual vascular endothelial cells, but only at the site of implantation. The selectins are responsive to inflammatory mediators, including cytokines. As the trophoblast cells replace maternal endothelium, the receptor profile for adhesion peptides of the trophoblast changes to resemble endothelial cells.<sup>204</sup> **It has been long recognized that this invasion process is limited in pregnancies with preeclampsia, and this is the fundamental cause of the poor placental perfusion associated with preeclampsia and intrauterine growth retardation.** The relative failure in this process in preeclampsia is characterized by insufficient conversion to endothelial adhesion receptors as well as low levels of IGF-binding protein-1 and matrix metalloproteinases.<sup>205,206,207</sup>

The matrix metalloproteinases, significantly involved in the process of menstruation (Chapter 3), are also key players in matrix degradation during trophoblast invasion. The metalloproteinases include collagenases, gelatinases, and the stromelysins. Integrin-mediated adhesion can activate this family of proteolytic enzymes, which then accomplish the degradation of matrix proteins that is necessary in order for trophoblast migration to take place. Production of the metalloproteinases is regulated by the combined actions of plasminogen activators, cytokines, and tissue inhibitors (TIMPs). Early trophoblastic invasion is enhanced by trophoblast-derived GnRH that suppresses the expression of TIMPs, the inhibitors of matrix metalloproteinases.<sup>208</sup>

Further penetration and survival depend on factors that are capable of suppressing the maternal immune response to fetal antigens. The endometrial tissue makes a significant contribution to growth factor activity and immune suppression by synthesizing proteins in response to the blastocyst even before implantation.<sup>209,210</sup> One of the great mysteries associated with implantation is the mechanism by which the

mother rejects a genetically abnormal embryo or fetus. Evidence from several mammalian species indicates that the endometrium is capable of “sensing” the quality of the attaching embryo, mounting a decidualization response that is tailored to individual embryos. Microarray analysis of bovine endometrium has revealed differential gene expression depending on the origin (somatic cell nuclear transfer, IVF, or artificial insemination) and developmental potential of the implanting embryo.<sup>211</sup> In humans, endometrial stromal cells have been shown in vitro in a coculture model to respond selectively to low-quality embryos by inhibiting the secretion of key implantation factors, including IL1-beta, HB-EGF, and LIF.<sup>212</sup> In addition, low-quality embryos elicit an endoplasmic stress response in human endometrial stromal cells in vitro, as well as in mouse uterus in vivo.<sup>213</sup>

The embryonic signals will be effective only in a proper hormone milieu. Much of the knowledge concerning the hormone requirements for implantation in animals has been gained from studies of animals with delayed implantation. In a number of species, preimplantation embryos normally lie dormant in the uterus for periods of time, which may extend for as long as 15 months before implantation is initiated. In other species, delayed implantation can be imposed by postpartum suckling or by performing ovariectomy on day 3 of pregnancy. This produces a marked decrease in synthesis of DNA and protein by the blastocyst. The embryo can be maintained at the blastocyst stage by injecting the mother with progesterone. Using this model, hormonal requirements for implantation have been determined. In mice, there is a requirement for estrogen and progesterone. In other species, including the primate, the nidatory stimulus of estrogen is not required, and progesterone alone is sufficient.<sup>135</sup> However, genomic profiling indicates that the presence of some estrogen facilitates the progesterone-induced gene expression associated with implantation.<sup>214</sup>

Although it is known that the hormone milieu of delayed implantation renders the embryo quiescent, it is not known whether this represents a direct effect on the embryo or whether there is a metabolic inhibitor present in uterine secretions that acts on the embryo. Removal of the embryo from the uterus to culture dishes allows rapid resumption of normal metabolism, suggesting that in fact, there has been a release from the inhibitory effects of a uterine product.

## **Limitation of Invasion**

Unlike the tissue invasion associated with cancer, trophoblast invasion must be limited, confining the placenta to its intrauterine location and within the time constraint of a pregnancy.

Invasion of the endometrial stromal compartment, breaching of the basement membrane, and penetration of maternal blood vessels are mediated by serine proteases

and metalloproteinases. The serine proteases are plasminogen activators that provide plasmin for proteolytic degradation of the extracellular matrix and activation of the metalloproteinase family. Trophoblast cells contain plasminogen activator receptors. Binding of plasminogen activator to this receptor is believed to be a method by which plasmin proteolysis is exerted in a controlled and limited site.<sup>215</sup>

Many components of the inflammatory response play roles in the process of implantation. Cytokine secretion from the lymphocyte infiltrate in the endometrium activates cellular lysis of trophoblast, perhaps an important process in limiting invasion.<sup>216</sup> The decidua at the time of implantation contains a large number of natural killer cells (large granular lymphocytes). It has been proposed that an interaction between these cells and a human leukocyte antigen uniquely present in invading trophoblast limits invasion by producing appropriate cytokines.<sup>217</sup>

Invasion by the trophoblast is limited by the formation of the decidual cell layer in the uterus. Fibroblast-like cells in the stroma are transformed into glycogen and lipid-rich cells. In the human, decidual cells surround blood vessels late in the nonpregnant cycle, but extensive decidualization does not occur until pregnancy is established. Ovarian steroids govern decidualization, and in the human, a combination of estrogen and progesterone is critical. Tissue factor (TF), expressed in decidualized endometrium, is a receptor for factor VII and its active form, VIIa. Concentrated in perivascular sites, TF forms what Lockwood calls a “hemostatic envelope” to promote hemostasis by providing fibrin.<sup>218,219</sup> TF is appropriately positioned to counteract the threat of hemorrhage associated with trophoblastic invasion.

Limitation of trophoblastic invasion is attributed to the balance of promoting and restraining growth factors, cytokines, and enzymes. Plasminogen activator inhibitor-1 (PAI-1) is a major product of decidual cells, inhibiting excessive bleeding during menses and restraining trophoblast invasion in early pregnancy.<sup>218,220</sup> PAI-1 binds plasminogen activator with a high affinity and is regulated by cytokines and growth factors. The metalloproteinases that degrade the extracellular matrix components, such as collagens, gelatins, fibronectin, and laminin, are restrained by TIMPs. In addition, metalloproteinase degradation can be suppressed by inhibiting trophoblast production of these enzymes and by preventing conversion from an inactive to an active form.<sup>221</sup> Decidual TGF- $\beta$  is a key growth factor involved in limitation of trophoblast invasion by inducing the expression of both TIMP and PAI-1. In addition, TGF- $\beta$  can inhibit integrin expression and influence cytotrophoblasts to differentiate into noninvasive syncytiotrophoblasts.<sup>199,222</sup> Decorin is a decidua-derived binding proteoglycan that can bind TGF- $\beta$ , storing it for when it is needed to limit invasion when it is freed and activated by plasmin. In addition, decorin exerts antiproliferative, antimigratory, and anti-invasive effects on trophoblast independently of TGF- $\beta$ .<sup>223</sup> Even hCG may exert a



governing force by inhibiting protease activity.<sup>190,224</sup>

In the baboon, the lower estrogen levels in early pregnancy permit trophoblast invasion, but the increasing estrogen levels later in pregnancy suppress maternal spiral artery invasion, an effect mediated by estrogen-induced decreases in cytotrophoblast VEGF expression.<sup>225,226</sup>

## Key Points: Implantation

- The early embryo enters the uterine cavity as an 8-cell morula and becomes a 32 to 256-cell blastocyst before implantation.
- Implantation begins with hatching from the zona pellucida about 1–3 days after the morula enters the uterine cavity.
- The endometrium is prepared for implantation by the complex activity of cytokines, growth factors, and lipids modulated by the sex hormones, especially progesterone. The endometrium is receptive for implantation for only a few days.
- The process of implantation begins with apposition and adhesion of the blastocyst to the uterine epithelium, about 2–4 days after the morula enters the uterine cavity. This process is mediated by cytokines and involves adhesion molecules (integrins) that interact with extracellular components, especially laminin and fibronectin.
- Trophoblastic invasion rapidly follows adhesion of the blastocyst, mediated by proteinase degradation of the extracellular matrix. The placenta is formed in the 2nd week after ovulation. Limitation of trophoblastic invasion is due to a restraint imposed by proteinase inhibitors, especially plasminogen activator inhibitor and tissue inhibitors of metalloproteinases.

# REFERENCES

1. **Medvei VC**, The History of Clinical Endocrinology, The Parthenon Publishing Group, New York, 1993.
2. **Bedford JM**, The contraceptive potential of fertilization: a physiological perspective, *Hum Reprod* 9:842, 1994.
3. **Marengo SR**, Maturing the sperm: unique mechanisms for modifying integral proteins in the sperm plasma membrane, *Anim Reprod Sci* 105:52, 2008.
4. **Foldesy RG, Bedford JM**, Biology of the scrotum. I. Temperature and androgens as determinants of the sperm storage capacity of the rat cauda epididymis, *Biol Reprod* 26:673, 1982.
5. **Orgebin-Crist M-C, Jahad N**, Maturation of rabbit epididymal sperm in organ culture: stimulation by epididymal cytoplasmic factors, *Biol Reprod* 21:511–515, 1979.
6. **Silber SJ, Ord T, Balmaceda J, Patrizio P, Asch RH**, Congenital absence of the vas deferens. The fertilizing capacity of human epididymal sperm, *N Engl J Med* 323:1788, 1990.
7. **Schoysman R**, Clinical situations challenging the established concept of epididymal physiology in the human, *Acta Eur Fertil* 24:55–60, 1993.
8. **Silber SJ**, Pregnancy caused by sperm from vasa efferentia, *Fertil Steril* 49:373–375, 1988.
9. **Devroey P, Liu J, Nagy Z, Tournaye H, Silber S, Van Steirteghem AC**, Normal fertilization of human oocytes after testicular sperm extraction and intracytoplasmic sperm injection, *Fertil Steril* 62:639, 1994.
10. **Sobrero AJ, MacLeod J**, The immediate postcoital test, *Fertil Steril* 13:184, 1962.
11. **Bedford JM**, The rate of sperm passage into the cervix after coitus in the rabbit, *J Reprod Fertil* 25:211, 1971.
12. **Yudin AI, Hanson FW, Katz DF**, Human cervical mucus and its interaction with sperm: a fine-structural view, *Biol Reprod* 40:661, 1989.
13. **Wang C, Baker HWG, Jennings MG, Burger HG, Lutjen P**, Interaction between human cervical mucus and sperm surface antibodies, *Fertil Steril* 44:484, 1985.
14. **Morales P, Katz DF, Overstreet JW, Samuels SJ, Chang RJ**, The relationship between the motility and morphology of spermatozoa in human semen, *J Androl* 9:241, 1988.
15. **Katz D, Morales P, Samuels SJ, Overstreet JW**, Mechanisms of filtration of morphologically abnormal human sperm by cervical mucus, *Fertil Steril* 54:513, 1990.
16. **Tollner TL, Yudin AL, Treece CA, Overstreet JW, Cherr GN**, Macaque sperm coating protein DEFB126 facilitates sperm penetration of cervical mucus, *Hum Reprod* 23:2523, 2008.
17. **Krzanowska H**, The passage of abnormal spermatozoa through the uterotubal junction of the mouse, *J Reprod Fertil* 38:81, 1974.
18. **Settlage DSF, Motoshima M, Tredway DR**, Sperm transport from the external cervical os to the fallopian tubes in women: a time and quantitation study, *Fertil Steril* 24:655, 1973.
19. **Schmiedehausen K, Kat S, Albert N, Platsch G, Wildt L, Kuwert T**, Determination of velocity of tubar transport with dynamic hysterosalpingoscintigraphy, *Nucl Med Commun* 24:865, 2003.
20. **Overstreet JW, Cooper GW**, Sperm transport in the reproductive tract of the female rabbit. I. Rapid transit phase and transport, *Biol Reprod* 19:101, 1978.
21. **Perloff WH, Steinberger E**, In vivo survival of spermatozoa in cervical mucus, *Am J Obstet Gynecol* 88:439, 1964.
22. **Williams M, Hill CJ, Scudamore I, Dunphy B, Cooke ID, Barratt CLR**, Sperm numbers and distribution within the human fallopian tube around ovulation, *Hum Reprod* 8:2019, 1993.
23. **Gould JE, Overstreet JW, Hanson FW**, Assessment of human sperm function after recovery from the female reproductive tract, *Biol Reprod* 31:888, 1984.
24. **Barratt CLR, Cooke ID**, Sperm transport in the human female reproductive tract—a dynamic interaction, *Int J Androl* 14:394, 1991.
25. **Katz DF, Drobnis EZ, Overstreet JW**, Factors regulating mammalian sperm migration through the female reproductive tract and oocyte vestments, *Gamete Res* 22:443, 1989.
26. **Murray SC, Smith TT**, Sperm interaction with Fallopian tube apical membrane enhances sperm motility and delays capacitation, *Fertil Steril* 68:351, 1997.

27. **Overstreet JW, Katz DF, Yudin AI**, Cervical mucus and sperm transport in reproduction, *Semin Perinatol* 15:149, 1991.
28. **Chang MC**, Fertilizing capacity of spermatozoa deposited into the fallopian tubes, *Nature* 168:697, 1951.
29. **Austin CR**, Observations on the penetration of the sperm into the mammalian egg, *Aust J Sci Res B* 4:581, 1951.
30. **Zaneveld LJD, De Jonge CJ, Anderson RA, Mack SR**, Human sperm capacitation and the acrosome reaction, *Hum Reprod* 6:1265, 1991.
31. **Yanagimachi R, Chang MC**, Fertilization of hamster eggs in vitro, *Nature* 200:281–282, 1963.
32. **Toyoda Y, Yokoyama M, Hosi T**, Studies on the fertilization of mouse eggs in vitro, *J Anim Reprod* 16:145–157, 1971.
33. **Tollner TL, Vandevoort CA, Yudin AI, Treece CA, Overstreet JW, Cherr GN**, Release of DEFB126 from macaque sperm and completion of capacitation are triggered by conditions that simulate periovulatory oviductal fluid, *Mol Reprod Dev* 76:431, 2009.
34. **Aitken RJ, Baker MA**, The role of proteomics in understanding sperm cell biology, *Int J Androl* 31:295, 2007.
35. **Oliva R, Martinez-Heredia J, Estanyol JM**, Proteomics in the study of the sperm cell composition, differentiation and function, *Syst Biol Reprod Med* 54:23, 2008.
36. **Tollner TL, Yudin AI, Tarantal AF, Treece CA, Overstreet JW, Cherr GN**, Beta-defensin 126 on the surface of macaque sperm mediates attachment of sperm to oviductal epithelia, *Biol Reprod* 78:400, 2008.
37. **Yanagimachi R**, Capacitation and the acrosome reaction, In: *Asch R, Balmaceda JP, Johnston I, eds. Gamete Physiology, Serono Symposia*, Norewell, 1990, p. 31.
38. **Cross NL, Morales P, Overstreet JW, Hanson FW**, Induction of acrosome reactions by the human zona pellucida, *Biol Reprod* 38:235, 1988.
39. **Suarez SS, Wolf DP, Meizel S**, Induction of the acrosome reaction in human spermatozoa by a fraction of human follicular fluid, *Gamete Res* 14:107, 1986.
40. **Aitken RJ**, Molecular mechanisms regulating human sperm function, *Mol Hum Reprod* 3:169, 1997.
41. **de Lamirande E, Leclerc P, Gagnon C**, Capacitation as a regulatory event that primes spermatozoa for the acrosome reaction and fertilization, *Mol Hum Reprod* 3:175, 1997.
42. **Jin SK, Yang WX**, Factors and pathways involved in capacitation: how are they regulated? *Oncotarget* 8(2):3600–3627, 2017. doi:10.18632/oncotarget.12274.
43. **Ravnik SE, Zarutskie PW, Muller CH**, Purification and characterization of a human follicular fluid lipid transfer protein that stimulates human sperm capacitation, *Biol Reprod* 47:1126, 1992.
44. **Benoff S, Hurley I, Cooper GW, Mandel FS, Rosenfeld DL, Hershag A**, Head-specific mannose-ligand receptor expression in human spermatozoa is dependent on capacitation-associated membrane cholesterol loss, *Hum Reprod* 8:2141, 1993.
45. **Overstreet JW, Gould JE, Katz DF**, In vitro capacitation of human spermatozoa after passage through a column of cervical mucus, *Fertil Steril* 34:604, 1980.
46. **Ducibella T**, Mammalian egg cortical granules and the cortical reaction, In: *Wassarman PM, ed. Elements of Mammalian Fertilization*, CRC Press, Boca Raton, 1991, p. 206.
47. **Sharma V, Pampiglione JS, Mason BA, Campbell S, Riddle A**, Experience with peritoneal oocyte and sperm transfer as an outpatient-based treatment for infertility, *Fertil Steril* 55:579, 1991.
48. **Clewe TH, Mastroianni L**, Mechanisms of ovum pickup: I. Functional capacity of rabbit oviducts ligated near the fimbriae, *Fertil Steril* 9:13, 1958.
49. **Crow J, Amso NN, Lewin J, Shaw RW**, Morphology and ultrastructure of Fallopian tube epithelium at different stages of the menstrual cycle and menopause, *Hum Reprod* 9:2224, 1994.
50. **Lyons RA, Djahanbakhch O, Mahmood T, Saridogan E, Sattar S, Sheaff MT, Naftalin AA, Chenoy R**, Fallopian tube ciliary beat frequency in relation to the stage of menstrual cycle and anatomical site, *Hum Reprod* 17:584, 2002.
51. **Tao A**, How the myosalpinx works in gamete and embryo transfer, *Arch Biol Med Exp* 24:361, 1991.
52. **Halbert SA, Tam PY, Blandau RJ**, Egg transport in the rabbit oviduct: the roles of cilia and muscle, *Science*

191:1052, 1976.

53. **Eddy CA, Flores JJ, Archer DR, Pauerstein CJ**, The role of cilia in infertility: an evaluation by selective microsurgical modification of the rabbit oviduct, *Am J Obstet Gynecol* 132:814, 1978.
54. **Halbert SA, Patton DL, Zarutskie PW, Soules MR**, Function and structure of cilia in the Fallopian tube of an infertile woman with Kartagener's syndrome, *Hum Reprod* 12:55, 1997.
55. **Ott HW, Schmiedehausen K, Kat S, Binder H, Gall C, Kuwert T, Heute D, Virgolini I, Wildt L**, Tubal transport of spermatozoa does not appear to be dependent on normal cilia function, *Fertil Steril* 88:1437, 2007.
56. **Wånggren K, Stavreus-Evers A, Olsson C, Andersson E, Gemzell-Danielsson K**, Regulation of muscular contractions in the human Fallopian tube through prostaglandins and progestagens, *Hum Reprod* 23:2359, 2008.
57. **Gordts S, Campo R, Rombauts L, Brosens I**, Endoscopic visualization of the process of fimbrial ovum retrieval in the human, *Hum Reprod* 13:1425, 1998.
58. **Gordts S, Campo R, Brosens I**, Endoscopic visualization of oocyte release and oocyte retrieval in humans, *Reprod Biomed Online* 4(Suppl 3):10, 2001.
59. **Gardner DK, Lane M, Calderon I, Leeton J**, Environment of the preimplantation human embryo in vivo: metabolite analysis of oviduct and uterine fluids and metabolism of cumulus cells, *Fertil Steril* 65(2):349–353, 1996.
60. **Sterin-Speziale N, Gimeno MF, Zapata C, Bagnati PE, Gimeno AL**, The effect of neurotransmitters, bradykinin, prostaglandins, and follicular fluid on spontaneous contractile characteristics of human fimbriae and tubo-ovarian ligaments isolated during different stages of the sexual cycle, *Int J Fertil* 23(1):1–11, 1978.
61. **Djahanbakhch O, Ezzati M, Saridogan E**, Physiology and pathophysiology of tubal transport: ciliary beat and muscular contractility, relevance to tubal infertility, recent research, and future directions. In: Ledger WL, Tan SL, Bahathiq A, eds. *The Fallopian Tube in Infertility and IVF Practice*, Cambridge University Press, Cambridge, 2010, pp. 18–29.
62. **Croxatto HB, Ortiz MS**, Egg transport in the fallopian tube, *Gynecol Invest* 6:215, 1975.
63. **Pauerstein CJ, Eddy CA**, The role of the oviduct in reproduction; our knowledge and our ignorance, *J Reprod Fertil* 55:223, 1979.
64. **Tompkins P**, Letter to the editor, *Fertil Steril* 31:696, 1979.
65. **Novy MJ**, Reversal of Kroener fimbriectomy sterilization, *Am J Obstet Gynecol* 137:198, 1980.
66. **Glass RH**, Fate of rabbit eggs fertilized in the uterus, *J Reprod Fertil* 31:139, 1972.
67. **Adams CE**, Consequences of accelerated ovum transport, including a re-evaluation of Estes' operation, *J Reprod Fertil* 55:239, 1979.
68. **Rosenwaks Z**, Donor eggs: their application in modern reproductive technologies, *Fertil Steril* 47:895, 1987.
69. **Ikle FA**, Pregnancy after implantation of the ovary into the uterus, *Gynaecologia* 151:95, 1961.
70. **Tesarik J, Mendoza C**, Nongenomic effects of 17 $\beta$ -estradiol on maturing human oocytes: relationship to oocyte developmental potential, *J Clin Endocrinol Metab* 80:1438, 1995.
71. **Taylor CT, Lawrence YM, Kingand CR, Biljan MM, Cuthbertson KSR**, Oscillations in intracellular free calcium induced by spermatozoa in human oocytes at fertilization, *Hum Reprod* 8:2174, 1993.
72. **France JT, Graham FM, Gosling L, Hair P, Knox BS**, Characteristics of natural conception cycles occurring in a prospective study of sex preselection: fertility awareness symptoms, hormone levels, sperm survival, and pregnancy outcome, *Int J Fertil* 37:244, 1992.
73. **Wilcox AJ, Weinberg CR, Baird DD**, Timing of sexual intercourse in relation to ovulation. Effects on the probability of conception, survival of the pregnancy, and sex of the baby, *N Engl J Med* 333:1517, 1995.
74. **Ralt D, Goldenberg M, Fetterolf P, Thompson D, Dor J, Mashiach S, Garbers DL, Eisenbach M**, Sperm attraction to a follicular factor(s) correlates with human egg fertilizability, *Proc Natl Acad Sci U S A* 88:2840, 1991.
75. **Eisenbach M, Ralt D**, Precontact mammalian sperm-egg communication and role in fertilization, *Am J Physiol* 262:1095, 1992.
76. **Eisenbach M, Giojalas LC**, Sperm guidance in mammals—an unpaved road to the egg, *Nat Rev Mol Cell Biol* 7:276, 2006.

77. **Cohen-Dayag A, Tur-Kaspa I, Dor J, Mashiach S, Eisenbach M**, Sperm capacitation in humans is transient and correlates with chemotactic responsiveness to follicular factors, *Proc Natl Acad Sci U S A* 92:11039, 1995.
78. **Talbot P**, Sperm penetration through oocyte investments in mammals, *Am J Anat* 174:331, 1985.
79. **Dietl JA, Rauth G**, Molecular aspects of mammalian fertilization, *Hum Reprod* 4:869, 1989.
80. **Wassarman PM**, Gamete interactions during mammalian fertilization, *Theriogenology* 41:31, 1994.
81. **Bedford JM**, Puzzles of mammalian fertilization—and beyond, *Int J Dev Biol* 52:415, 2008.
82. **Hartmann JF, Gwatkin RBL**, Alteration of sites on the mammalian sperm surface following capacitation, *Nature* 234:479, 1971.
83. **Zaneveld LJD, Polakoski KL, Williams WL**, Properties of a proteolytic enzyme from rabbit sperm acrosomes, *Biol Reprod* 6:30, 1972.
84. **Jones R**, Identification and functions of mammalian sperm-egg recognition molecules during fertilization, *J Reprod Fertil* 42(Suppl):89, 1990.
85. **Shabanowitz RB, O’Rand MG**, Characterization of the human zona pellucida from fertilized and unfertilized eggs, *J Reprod Fertil* 82:151, 1988.
86. **Lefièvre L, Conner SJ, Salpekar A, Olufowobi O, Ashton P, Pavlovic B, Lenton W, Afnan M, Brewis IA, Monk M, Hughes DC, Barratt CL**, Four zona pellucida glycoproteins are expressed in the human, *Hum Reprod* 19:1580, 2004.
87. **Jovine L, Qi H, Williams Z, Litscher ES, Wassarman PM**, Features that affect secretion and assembly of zona pellucida glycoproteins during mammalian oogenesis, *Soc Reprod Fertil Suppl* 63:187, 2007.
88. **Wassarman PM**, Zona pellucida glycoproteins, *J Biol Chem* 283:2485, 2008.
89. **Chakravarty S, Kadunganattil S, Bansal P, Sharma RK, Gupta SK**, Relevance of glycosylation of human zona pellucida glycoproteins for their binding to capacitated human spermatozoa and subsequent induction of acrosomal exocytosis, *Mol Reprod Dev* 75:75, 2008.
90. **Dean J**, Biology of mammalian fertilization: role of the zona pellucida, *J Clin Invest* 89:1055, 1992.
91. **Rankin T, Dean J**, The molecular genetics of the zona pellucida: mouse mutations and infertility, *Mol Hum Reprod* 2:889, 1996.
92. **Liu C, Litscher ES, Mortillo S, Sakai Y, Kinloch RA, Stewart CL, Wassarman PM**, Targeted disruption of the ZP3 gene results in production of eggs lacking a zona pellucida and infertility in female mice, *Proc Natl Acad Sci U S A* 93:5431, 1996.
93. **Fayrer-Hosken R**, Controlling animal populations using anti-fertility vaccines, *Reprod Domest Anim* 43(Suppl 2):179, 2008.
94. **Choudhury S, Srivastava N, Narwal PS, Rath A, Jaiswal S, Gupta SK**, Feasibility and challenges in the development of immunocontraceptive vaccine based on zona pellucida glycoproteins, *Soc Reprod Fertil Suppl* 63:479, 2007.
95. **Wassarman PM**, Mouse gamete adhesion molecules, *Biol Reprod* 46:86, 1992.
96. **Leyton L, LeGuen P, Bunch D, Saling PM**, Regulation of mouse gamete interaction by a sperm tyrosine kinase, *Proc Natl Acad Sci U S A* 89:11692, 1992.
97. **Burks DJ, Carballada R, Moore HD, Saling PM**, Interaction of a tyrosine kinase from human sperm with the zona pellucida at fertilization, *Science* 269:83, 1995.
98. **Florman HM, Tombes RM, First NL, Babcock DF**, An adhesion-associated agonist from the zona pellucida activates G protein-promoted elevations of internal Ca<sup>2+</sup> and pH that mediate mammalian sperm acrosomal exocytosis, *Dev Biol* 135:133, 1989.
99. **Ward CR, Storey BT, Kopf GS**, Selective activation of Gi1 and Gi2 in mouse sperm by the zona pellucida, the egg’s extracellular matrix, *J Biol Chem* 269:13254, 1994.
100. **Aitken RJ, McLaughlin EA**, Molecular mechanisms of sperm capacitation: progesterone-induced secondary calcium oscillations reflect the attainment of a capacitated state, *Soc Reprod Fertil Suppl* 63:273, 2007.
101. **O’Toole CMB, Roldan ERS, Fraser LR**, Protein kinase C activation during progesterone-stimulated acrosomal exocytosis in human spermatozoa, *Mol Hum Reprod* 2:921, 1996.
102. **Walsh A, Whelan D, Bielanowicz A, Skinner B, Aitken RJ, O’Bryan MK, Nixon B**, Identification of the

molecular chaperone, heat shock protein 1 (Chaperonin 10), in the reproductive tract and in capacitating spermatozoa in the male mouse, *Biol Reprod* 78:983, 2008.

103. **Chiu PCN, Chung M-K, Koistinen R, Koistinen H, Seppala M, Ho P-C, Ng EHY, Lee K-F, Yeung WSB**, Gycodelin-A interacts with fucosyltransferase on human sperm plasma membrane to inhibit spermatozoa-zona pellucida binding, *J Cell Sci* 120:33, 2007.
104. **Green DPL**, Mammalian fertilization as a biological machine: a working model for adhesion and fusion of sperm and oocyte, *Hum Reprod* 8:91, 1993.
105. **Bedford JM**, Why do penetrating sperm create an oblique path in the zona pellucida?, *Reproduction* 131:23, 2006.
106. **Lathrop WF, Carmichael EP, Myles DG, Primakoff P**, cDNA cloning reveals the molecular structure of a sperm surface protein, PH-20, involved in sperm-egg adhesion and the wide distribution of its gene among mammals, *J Cell Biol* 111:1939, 1990.
107. **Blobel CP, Wolfsberg TG, Turck CW, Myles DG, Primakoff P, White J**, A potential fusion peptide and an integrin ligand domain in a protein active in sperm-egg fusion, *Nature* 356:248, 1992.
108. **Lin Y, Mahan K, Lathrop WF, Myles DG, Primakoff P**, A hyaluronidase activity of the sperm plasma membrane protein PH-20 enables sperm to penetrate the cumulus cell layer surrounding the egg, *J Cell Biol* 125:1157, 1994.
109. **Fusi FM, Vignali M, Gailit J, Bronson RA**, Mammalian oocytes exhibit specific recognition of the RGD (Arg-Gly-Asp) tripeptide and express oolemmal integrins, *Mol Reprod Dev* 36:212, 1993.
110. **Fusi FM, Bernocchi N, Ferrari A, Bronson RA**, Is vitronectin the velcro that binds the gametes together?, *Mol Hum Reprod* 2:859, 1996.
111. **McLaughlin EA, Frayne J, Bloomberg G, Hall L**, Do fertilin b and cyritestin play a major role in mammalian sperm-oolemma interactions? A critical re-evaluation of the use of peptide mimics in identifying specific oocyte recognition proteins, *Mol Hum Reprod* 7:313, 2001.
112. **Tamphaichitr N, Carmona E, Khalil MB, Xu H, Berger T, Gerton GL**, New insights into sperm-zona pellucida interaction: involvement of sperm lipid rafts, *Front Biosci* 12:1748, 2007.
113. **Swann K**, Soluble sperm factors and Ca<sup>2+</sup> release in eggs at fertilization, *Rev Reprod* 1:33, 1996.
114. **Swann K, Yu Y**, The dynamics of calcium oscillations that activate mammalian eggs, *Int J Dev Biol* 52:585, 2008.
115. **Terada Y, Hasegawa H, Takahashi A, Ugajin T, Yaegashi N, Okamura K**, Successful pregnancy after oocyte activation by a calcium ionophore for a patient with recurrent intracytoplasmic sperm injection failure, with an assessment of oocyte activation and sperm centrosomal function using bovine eggs, *Fertil Steril* 91:935, 2009.
116. **Barros C, Yanagimachi R**, Induction of zona reaction in golden hamster eggs by cortical granule material, *Nature* 233:2368, 1971.
117. **Sathananthan AH, Trounson AO**, Ultrastructure of cortical granule release and zona interaction in monospermic and polyspermic human ova fertilized in vitro, *Gamete Res* 6:225, 1982.
118. **Ducibella T, Matson S**, Secretory mechanisms and Ca<sup>2+</sup> signaling in gametes: similarities to regulated neuroendocrine secretion in somatic cells and involvement in emerging pathologies, *Endocr Pathol* 18:191, 2007.
119. **Ducibella T, Fissore R**, The roles of Ca<sup>2+</sup>, downstream protein kinases, and oscillatory signaling in regulating fertilization and the activation of development, *Dev Biol* 315:257, 2008.
120. **Lopata A, Sathananthan AH, McBain JC, Johnston WIH, Speirs AL**, The ultrastructure of preovulatory human eggs fertilized in vitro, *Fertil Steril* 33:12, 1980.
121. **Balakier H, MacLusky NJ, Casper RF**, Characterization of the first cell cycle in human zygotes: implications for cryopreservation, *Fertil Steril* 59:359, 1993.
122. **Braude P, Bolton V, Moore S**, Human gene expression first occurs between the four and eight cell stages of preimplantation development, *Nature* 332:459, 1988.
123. **Artley JK, Braude PR**, Biochemistry of the preimplantation embryo, *Assist Reprod Rev* 3:13, 1993.
124. **Stitzel ML, Seydoux G**, Regulation of the oocyte-to-zygote transition, *Science* 316:407, 2007.
125. **LaLancette C, Miller D, Li Y, Krawetz SA**, Paternal contributions: new functional insights for spermatozoal

RNA, *J Cell Biochem* 104:1570, 2008.

126. **Hurst PR, Jefferies K, Eckstein P, Wheeler AG**, Recovery of uterine embryos in rhesus monkeys, *Biol Reprod* 15:429, 1976.
127. **Hendrickx AG, Kraemer DC**, Preimplantation stages of baboon embryos, *Anat Rec* 162:111, 1968.
128. **Hertig AT, Rock J, Adams EC, Menkin MC**, Thirty-four fertilized ova, good, bad and indifferent from 210 women of known fertility, *Pediatrics* 23:202, 1959.
129. **Zinaman MJ, Clegg ED, Brown CC, O'Connor J, Selevan SG**, Estimates of human fertility and pregnancy loss, *Fertil Steril* 65:503, 1996.
130. **Wilcox AJ, Weiberg CR, O'Connor JF, Baird DD, Schlatterer JP, Canfield RE, Armstrong EG, Nisula BC**, Incidence of early loss of pregnancy, *N Engl J Med* 319:189, 1988.
131. **Little AB**, There's many a slip 'twixt' implantation and the crib (editorial), *N Engl J Med* 319:241, 1988.
132. **Ohno M, Maeda T, Matsunobu A**, A cytogenetic study of spontaneous abortions with direct analysis of chorionic villi, *Obstet Gynecol* 77:394, 1991.
133. **Tabibzadeh S, Babaknia A**, The signals and molecular pathways involved in implantation, a symbiotic interaction between blastocyst and endometrium involving adhesion and tissue invasion, *Mol Hum Reprod* 1:1579, 1995.
134. **Sharkey AM, Smith SK**, The endometrium as a cause of implantation failure, *Best Practice & Research, Clin Obstet Gynecol* 17:289, 2003.
135. **Ghosh D, De P, Sengupta J**, Luteal phase ovarian oestrogen is not essential for implantation and maintenance of pregnancy from surrogate embryo transfer in the rhesus monkey, *Hum Reprod* 9:629, 1994.
136. **Leitao B, Jones MC, Fusi L, Higham J, Lee Y, Takano M, Goto T, Christian M, Lam EW, Brosens JJ**, Silencing of the JNK pathway maintains progesterone receptor activity in decidualizing human endometrial stromal cells exposed to oxidative stress signals, *FASEB J* 24:1541–1551, 2010.
137. **Burton GJ, Watson AL, Hempstock J, Skepper JN, Jauniaux E**, Uterine glands provide histiotrophic nutrition for the human fetus during the first trimester of pregnancy, *J Clin Endocrinol Metab* 87:2954, 2002.
138. **Psychoyos A**, Uterine receptivity for nidation, *Ann N Y Acad Sci* 476:36, 1986.
139. **Formigli L, Formigli G, Roccio C**, Donation of fertilized uterine ova to infertile women, *Fertil Steril* 47:162, 1987.
140. **Navot D, Scott RT, Droesch K, Veeck LL, Liu HC, Rosenwaks Z**, The window of embryo transfer and the efficiency of human conception in vitro, *Fertil Steril* 55:114, 1991.
141. **Tapia A, Gangi LM, Zegers-Hochschild F, Balmaceda J, Pommer R, Trejo L, Pacheco IM, Salvatierra AM, Henríquez S, Quezada M, Vargas M, Ríos M, Munroe DJ, Croxatto HB, Velasquez L**, Differences in the endometrial transcript profile during the receptive period between women who were refractory to implantation and those who achieved pregnancy, *Hum Reprod* 23:340, 2008.
142. **Diedrich K, Fauser BCJM, Devroey P, Griesinger G**, on behalf of the **Evian Annual Reproduction (EVAR) Workshop Group**, The role of the endometrium and embryo in human implantation, *Hum Reprod Update* 13:365, 2007.
143. **Martel D, Frydman R, Glissant M, Maggioni C, Roche D, Psychoyos A**, Scanning electron microscopy of postovulatory human endometrium in spontaneous cycles and cycles stimulated by hormone treatment, *J Endocrinol* 114:319, 1987.
144. **Bentin-Ley U**, Relevance of endometrial pinopodes for human blastocyst implantation, *Hum Reprod* 15(Suppl 6):67, 2000.
145. **Gipson IK, Blalock T, Tisdale A, Spurr-Michaud S, Allcorn S, Stavreus-Evers A, Gemzell K**, MUC16 is lost from the uterodome (pinopode) surface of the receptive human endometrium: in vitro evidence that MUC16 is a barrier to trophoblast adherence, *Biol Reprod* 78:132, 2008.
146. **Stavreus-Evers A, Nikas G, Sahlin L, Eriksson H, Landgren B-M**, Formation of pinopodes in human endometrium is associated with the concentrations of progesterone and progesterone receptors, *Fertil Steril* 76:782, 2001.
147. **Quinn C, Ryan E, Claessens EA, Greenblatt E, Hawrylyshyn P, Cruickshank B, Hannam T, Dunk C, Casper RF**, The presence of pinopodes in the human endometrium does not delineate the implantation

window, *Fertil Steril* 87:1015, 2007.

148. **Bhurke AS, Bagchi IC, Bagchi MK**, Progesterone-regulated endometrial factors controlling implantation, *Am J Reprod Immunol* 75(3):237–245, 2016. doi:10.1111/aji.12473.
149. **Vasquez YM, DeMayo FJ**, Role of nuclear receptors in blastocyst implantation, *Semin Cell Dev Biol* 24(0), 2013. doi:10.1016/j.semcdb.2013.08.004.
150. **Morton H, Rolfe BE, Cavanagh AC**, Early pregnancy factor, *Semin Reprod Endocrinol* 10:72, 1992.
151. **Lopata A, Hay D**, The surplus human embryo: its potential for growth, blastulation, hatching, and human chorionic gonadotropin production in culture, *Fertil Steril* 51:984, 1989.
152. **Bonduelle M, Dodd R, Liebaers I, Steirteghem A, Williamson R, Akhurst R**, Chorionic gonadotropin-b mRNA, a trophoblast marker, is expressed in human 8-cell embryos derived from trippronucleate zygotes, *Hum Reprod* 3:909, 1988.
153. **Stewart DR, Overstreet JW, Nakajima ST, Lasley BL**, Enhanced ovarian steroid secretion before implantation in early human pregnancy, *J Clin Endocrinol Metab* 76:1470, 1993.
154. **Csapo AL, Pulkkinen MO, Wiest WG**, Effects of luteectomy and progesterone replacement in early pregnant patients, *Am J Obstet Gynecol* 115:759, 1973.
155. **Stevens VC**, Potential control of fertility in women by immunization with HCG, *Res Reprod* 7:1, 1975.
156. **Sueoka K, Dharmarajan AM, Miyazaki T, Atlas SJ, Wallach E**, Platelet activating factor-induced early pregnancy factor activity from the perfused rabbit ovary and oviduct, *Am J Obstet Gynecol* 159:1580, 1988.
157. **Hemmings R, Langlais J, Falcone T, Granger L, Miron P, Guyda H**, Human embryos produce transforming growth factor  $\alpha$  activity and insulin-like growth factor II, *Fertil Steril* 58:101, 1992.
158. **Hoffman LH, Davenport GR, Brash AR**, Endometrial prostaglandins and phospholipase activity related to implantation in rabbits: effects of dexamethasone, *Biol Reprod* 38:544, 1984.
159. **Kennedy TG**, Interactions of eicosanoids and other factors in blastocyst implantation, In: Hiller K, ed. *Eicosanoids and Reproduction*, MTP Press, Lancaster, 1987, p. 73.
160. **van der Weiden RMF, Helmerhorst FM, Keirse MJNC**, Influence of prostaglandins and platelet activating factor on implantation, *Hum Reprod* 6:436, 1991.
161. **Holmes PV, Sjogren A, Hamberger L**, Prostaglandin-E<sub>2</sub> released by pre-implantation human conceptuses, *J Reprod Immunol* 17:79, 1989.
162. **Harper MJK**, Platelet-activating factor: a paracrine factor in preimplantation stages of reproduction?, *Biol Reprod* 40:907, 1989.
163. **Nicola C, Chirpac A, Lala PK, Chakraborty C**, Roles of Rho guanosine 5'-triphosphatase A, Rho kinases, and extracellular signal regulated kinase (1/2) in prostaglandin E<sub>2</sub>-mediated migration of first-trimester human extravillous trophoblast, *Endocrinology* 149:1243, 2008.
164. **Smith SK**, Angiogenesis and implantation, *Hum Reprod* 15(Suppl 6):59, 2000.
165. **Sharkey AM, Catalano R, Evans A, Charnock-Jones DS, Smith SK**, Novel antiangiogenic agents for use in contraception, *Contraception* 71:263, 2005.
166. **Wilcox AJ, Baird DD, Weinberg CR**, Time of implantation of the conceptus and loss of pregnancy, *N Engl J Med* 340:1796, 1999.
167. **Gonzales DS, Jones JM, Pinyopummintr T, Carnevale EM, Ginther OJ, Shapiro SS, Bavister BD**, Trophoblast projections: a potential means for locomotion, attachment and implantation of bovine, equine and human blastocysts, *Hum Reprod* 11:2739, 1996.
168. **Simón C, Gimeno MJ, Mercader A, Francés A, Velasco JG, Remohi J, Polan ML, Pellicer A**, Cytokines–adhesion molecules–invasive proteinases. The missing paracrine/autocrine link in embryonic implantation?, *Mol Hum Reprod* 2:405, 1996.
169. **Pollard JW, Hunt JS, Wiktor-Jedrzejczak W, Stanley ER**, A pregnancy defect in the osteopetrotic (op/op) mouse demonstrates the requirement for CSF-1 in female fertility, *Dev Biol* 148:273, 1991.
170. **Stewart CL, Kaspar P, Brunet LJ, Bhatt H, Gadi I, Kontgen F, Abbondanzo SJ**, Blastocyst implantation depends on maternal expression of leukemia inhibitory factor, *Nature* 359:76, 1992.
171. **Cullinan EB, Abbondanzo SJ, Anderson PS, Pollard JW, Lessey BA, Stewart CL**, Leukemia inhibitory factor (LIF) and LIF receptor expression in human endometrium suggests a potential autocrine/paracrine



- function in regulating embryo implantation, *Proc Natl Acad Sci U S A* 93:3115, 1996.
172. **Raga F, Casañ EM, Bonilla-Musoles F**, Gonadotropin-releasing hormone (GnRH)-I regulation of interleukin (IL)-1b and IL-1 receptor antagonist expression in cultured human endometrial stromal cells, *J Obstet Gynaecol Res* 34:464, 2008.
  173. **Das SK, Wang X-N, Paria BC, Damm D, Abraham JA, Klagsbrun M, Andrews GK, Dey SK**, Heparin-binding EGF-like growth factor gene is induced in the mouse uterus temporarily by the blastocyst solely at the site of its apposition: a possible ligand for interaction with blastocyst EGF-receptor in implantation, *Development* 120:1071, 1994.
  174. **Fukuda MN, Sugihara K**, Signal transduction in human embryo implantation, *Cell Cycle* 6:1153, 2007.
  175. **Burrows TD, King A, Loke YW**, Trophoblast migration during human placental implantation, *Hum Reprod Update* 2:307, 1996.
  176. **Church HJ, Vicovac LM, Williams DL, Hey NA, Aplin JD**, Laminins 2 and 4 expressed by human decidual cells, *Lab Invest* 74:21, 1996.
  177. **Lessey BA, Castelbaum AJ, Buck CA, Lei Y, Yowell CW, Sun J**, Further characterization of endometrial integrins during the menstrual cycle and in pregnancy, *Fertil Steril* 62:497, 1994.
  178. **Klentzeris LD, Bulmer JN, Trejdosiewicz LK, Morrison L, Cooke ID**, Beta-1 integrin cell adhesion molecules in the endometrium of fertile and infertile women, *Hum Reprod* 8:1223, 1994.
  179. **Sutherland AE, Calarco PG, Damsky CH**, Developmental regulation of integrin expression at the time of implantation in the mouse embryo, *Development* 119:1175, 1993.
  180. **Vacca RA, Marra E, Loverro G, Maiorano E, Napoli A, Lovecchio M, Selvaggi L, Perlino E**, Differential expression of b1c integrin messenger ribonucleic acid and protein levels in human endometrium and decidua during the menstrual cycle and pregnancy, *J Clin Endocrinol Metab* 88:720, 2003.
  181. **Fujiwara H, Yoshioka S, Tatsumi K, Kosaka K, Satho Y, Nishioka Y, Egawa M, Higuchi T, Fujii S**, Human endometrial epithelial cells express ephrin A1: possible interaction between human blastocysts and endometrium via Eph-Ephrin system, *J Clin Endocrinol Metab* 87:5801, 2002.
  182. **Chard T**, Cytokines in implantation, *Hum Reprod Update* 1:385, 1995.
  183. **Sobel JS, Nebel L**, Changes in concanavalin A agglutinability during development of the inner cell mass and trophoblast of mouse blastocyst in vitro, *J Reprod Fertil* 52:239, 1978.
  184. **Ponnampalam AP, Weston GC, Trajstman AC, Susil B, Rogers PA**, Molecular classification of human endometrial cycle stages by transcriptional profiling, *Mol Hum Reprod* 10:879–893, 2004.
  185. **Riesewijk A, Martín J, van Os R, Horcajadas JA, Polman J, Pellicer A**, et al, Gene expression profiling of human endometrial receptivity on days LH+ 2 versus LH+ 7 by microarray technology, *Mol Hum Reprod* 9:253, 2003.
  186. **Schlafke S, Enders AC**, Cellular basis of interaction between trophoblast and uterus at implantation, *Biol Reprod* 12:41, 1975.
  187. **Larsen JF**, Electron microscopy of the implantation site in the rabbit, *Am J Anat* 109:319, 1961.
  188. **Strickland S, Reich E, Sherman MI**, Plasminogen activator in early embryogenesis: enzyme production by trophoblast and parietal endoderm, *Cell* 9:231, 1976.
  189. **Queenan JT, Kao LC, Arboleda CE, Ulloa-Aguirre A, Golos TG, Cines DB, Strauss JF**, Regulation of urokinase-type plasminogen activator production by cultured human cytotrophoblasts, *J Biol Chem* 262:10903, 1987.
  190. **Milwidsky A, Finci-Yeheskel Z, Yagel S, Mayer M**, Gonadotropin-mediated inhibition of proteolytic enzymes produced by human trophoblast in culture, *J Clin Endocrinol Metab* 76:1101, 1993.
  191. **Glass RH, Aggeler J, Spindle A, Pedersen RA, Werb Z**, Degradation of extracellular matrix by mouse trophoblast outgrowths: a model for implantation, *J Cell Biol* 96:1108, 1983.
  192. **Moll UM, Lane BL**, Proteolytic activity of first trimester human placenta: localization of interstitial collagenase in villous and extravillous trophoblast, *Histochemistry* 94:555, 1990.
  193. **Glass RH, Spindle AI, Pedersen RA**, Mouse embryo attachment to substratum and the interaction of trophoblast with cultured cells, *J Exp Zool* 203:327, 1979.
  194. **Hess AP, Hamilton AE, Talbi S, Dosiou C, Nyegaard M, Nayak N, Genbecev-Krtolica O**,

- Mavrogianis P, Ferrer K, Kruessel J, Fazleabas AT, Fisher SJ, Giudice LC**, Decidual stromal cell response to paracrine signals from the trophoblast: amplification of immune and angiogenic modulators, *Biol Reprod* 76:102, 2007.
195. **Herr F, Baal N, Reisinger K, Lorenz A, McKinnon T, Preissner KT, Zygmunt M**, HCG in the regulation of placental angiogenesis. Results of an in vitro study, *Placenta* 28(Suppl A):S85, 2007.
  196. **Licht P, Fluhr H, Neuwinger J, Wallwiener D, Wildt L**, Is human chorionic gonadotropin directly involved in the regulation of human implantation?, *Mol Cell Endocrinol* 269:85, 2007.
  197. **Levine RJ, Maynard SE, Qian C, Lim KH, England LJ, Yu KF, Schisterman EF, Thadhani R, Sachs BP, Epstein FH, Sibai BM, Sukhatme VP, Karumanchi SA**, Circulating angiogenic factors and the risk of preeclampsia, *N Engl J Med* 350:672, 2004.
  198. **Levine RJ, Lam C, Qian C, Yu KF, Maynard SE, Sachs BP, Sibai BM, Epstein FH, Romero R, Thadhani R**, et al, Soluble endoglin and other circulating antiangiogenic factors in preeclampsia, *N Engl J Med* 355:992, 2006.
  199. **Irving JA, Lala PV**, Functional role of cell surface integrins on human trophoblast cell migration: regulation by TGF- $\beta$ , IGF-II and IGFBP-1, *Exp Cell Res* 217:419, 1995.
  200. **Hamilton GS, Lysiak JJ, Han VKM, Lala PK**, Autocrine-paracrine regulation of human trophoblast invasiveness by insulin-like growth factor (IGF)-II and IGF-binding protein (IGFBP)-1, *Exp Cell Res* 244:147, 1998.
  201. **Damsky CH, Librach C, Lim K-H, Fitzgerald ML, McMaster MT, Janatpour M, Zhou Y, Logan SK, Fisher SJ**, Integrin switching regulates normal trophoblast invasion, *Development* 120:3657, 1994.
  202. **Diamond MS, Springer TA**, The dynamic regulation of integrin adhesiveness, *Curr Biol* 4:506, 1994.
  203. **Gleeson LM, Chakraborty C, McKinnon T, Lala PK**, Insulin-like growth factor-binding protein 1 stimulates human trophoblast migration by signaling through  $\alpha 5 \beta 1$  integrin via mitogen-activated protein kinase pathway, *J Clin Endocrinol Metab* 86:2484, 2001.
  204. **Zhou Y, Fisher SJ, Janatpour M, Genbacev O, Dejana E, Wheelock M, Damsky CH**, Human cytotrophoblasts adopt a vascular phenotype as they differentiate. A strategy for successful endovascular invasion?, *J Clin Invest* 99:2139, 1997.
  205. **Zhou Y, Damsky CH, Fisher SJ**, Preeclampsia is associated with failure of cytotrophoblasts to mimic a vascular adhesion phenotype: one cause of defective endovascular invasion in this syndrome?, *J Clin Invest* 99:2152, 1997.
  206. **Anim-Nyame N, Hills FA, Sooranna SR, Steer PJ, Johnson MR**, A longitudinal study of maternal plasma insulin-like growth factor binding protein-1 concentrations during normal pregnancy and pregnancies complicated by pre-eclampsia, *Hum Reprod* 15:2215, 2000.
  207. **Lyall F**, Mechanisms regulating cytotrophoblast invasion in normal pregnancy and pre-eclampsia, *Aust N Z J Obstet Gynaecol* 46:266, 2006.
  208. **Raga F, Casañ EM, Wen Y, Huang H-Y, Bonilla-Musoles F, Plan ML**, Independent regulation of matrix metalloproteinase-9, tissue inhibitor of metalloproteinase-1 (TIMP-1), and TIMP-3 in human endometrial stromal cells by gonadotropin-releasing hormone: implications in early human implantation, *J Clin Endocrinol Metab* 84:636, 1999.
  209. **Clark DA, Slapsys RM, Croy BA, Kreck J, Rossant J**, Local active suppression by suppressor cells in the decidua: a review, *Am J Reprod Immunol* 6:78, 1984.
  210. **Salmonsén LA, Doughton BW, Findlay JF**, The effect of the preimplantation blastocyst in vivo and in vitro on protein synthesis and secretion by cultured epithelial cells from sheep endometrium, *Endocrinology* 119:622, 1986.
  211. **Mansouri-Attia N**, et al., Endometrium as an early sensor of in vitro embryo manipulation technologies, *Proc Natl Acad Sci U S A* 106(14):5687–5692, 2009. doi:10.1073/pnas.0812722106.
  212. **Teklenburg G**, Natural selection of human embryos: decidualizing endometrial stromal cells serve as sensors of embryo quality upon implantation. *PLoS One* 5(4):e10258, 2010. doi:10.1371/journal.pone.0010258.
  213. **Brosens JJ**, et al., Uterine selection of human embryos at implantation, *Sci Rep* 4:3894, 2014. doi:10.1038/srep03894.

214. **Dassen H, Punyadeera C, Kamps R, Klomp J, Dunselman G, Dijcks F, de Goeij A, Ederveen A, Groothuis P**, Progesterone regulation of implantation-related genes: new insights into the role of oestrogen, *Cell Mol Life Sci* 64:1009, 2007.
215. **Roldan A, Cubellis MV, Masucci MT, Behrendt N, Lund LR, Dano K, Appella E, Blasi F**, Cloning and expression of the receptor for human urokinase plasminogen activator, a central molecule in cell surface, plasmin dependent proteolysis, *EMBO J* 9:467, 1990.
216. **King A, Loke YW**, Trophoblast and JEG choriocarcinoma cells are sensitive to lysis by IL-2 stimulated decidual LGL, *Cell Immunol* 129:435, 1990.
217. **Loke YW, King A**, Recent developments in the human maternal-fetal immune interaction, *Curr Opin Immunol* 3:762, 1991.
218. **Lockwood CJ, Krikun G, Rahman M, Caze R, Buchwalder L, Schatz F**, The role of decidualization in regulating endometrial hemostasis during the menstrual cycle, gestation, and in pathological states, *Semin Thromb Hemost* 33:111, 2007.
219. **Lockwood CJ, Krikun G, Gaze R, Rahman M, Buchwalder LF, Schatz F**, Decidual cell-expressed tissue factor in human pregnancy and its involvement in hemostasis and preeclampsia-related angiogenesis, *Ann N Y Acad Sci* 1127:67, 2008.
220. **Schatz F, Aigner S, Papp C, Toth-Pal E, Hausknecht V, Lockwood CJ**, Plasminogen activator activity during decidualization of human endometrial stromal cells is regulated by plasminogen activator inhibitor 1, *J Clin Endocrinol Metab* 80:1504, 1995.
221. **McDonnell S, Wright JH, Gaire M, Matrisian LM**, Expression and regulation of stromelysin and matrilysin by growth factors and oncogenes, *Biochem Soc Trans* 22:55, 1994.
222. **Graham CH, Lysiak JJ, McCrae KR, Lal PK**, Localization of transforming growth factor-beta at the human fetal-maternal interface: role in trophoblast growth and differentiation, *Biol Reprod* 46:561, 1992.
223. **Iacob D, Cai J, Tsonis M, Babwah A, Chakraborty C, Bhattacharjee RN, Lala PK**, Decorin-mediated inhibition of proliferation and migration of the human trophoblast via different tyrosine kinase receptors, *Endocrinology* 149:6187, 2008.
224. **Yagel S, Geva TE, Solomon H, Shimonovitz S, Finci-Yeheskel Z, Mayer M, Milwidsky A**, High levels of chorionic gonadotropin retard first trimester trophoblast invasion in vitro by decreasing urokinase plasminogen activator and collagenase activities, *J Clin Endocrinol Metab* 77:1506, 1993.
225. **Albrecht ED, Bonagura TW, Burleigh DW, Enders AC, Aberdeen GW, Pepe GJ**, Suppression of extravillous trophoblast invasion of uterine spiral arteries by estrogen during early baboon pregnancy, *Placenta* 27:483, 2006.
226. **Bonagura TW, Pepe GJ, Enders AC, Albrecht ED**, Suppression of extravillous trophoblast vascular endothelial growth factor expression and uterine spiral artery invasion by estrogen during early baboon pregnancy, *Endocrinology* 149:5078, 2008.

---

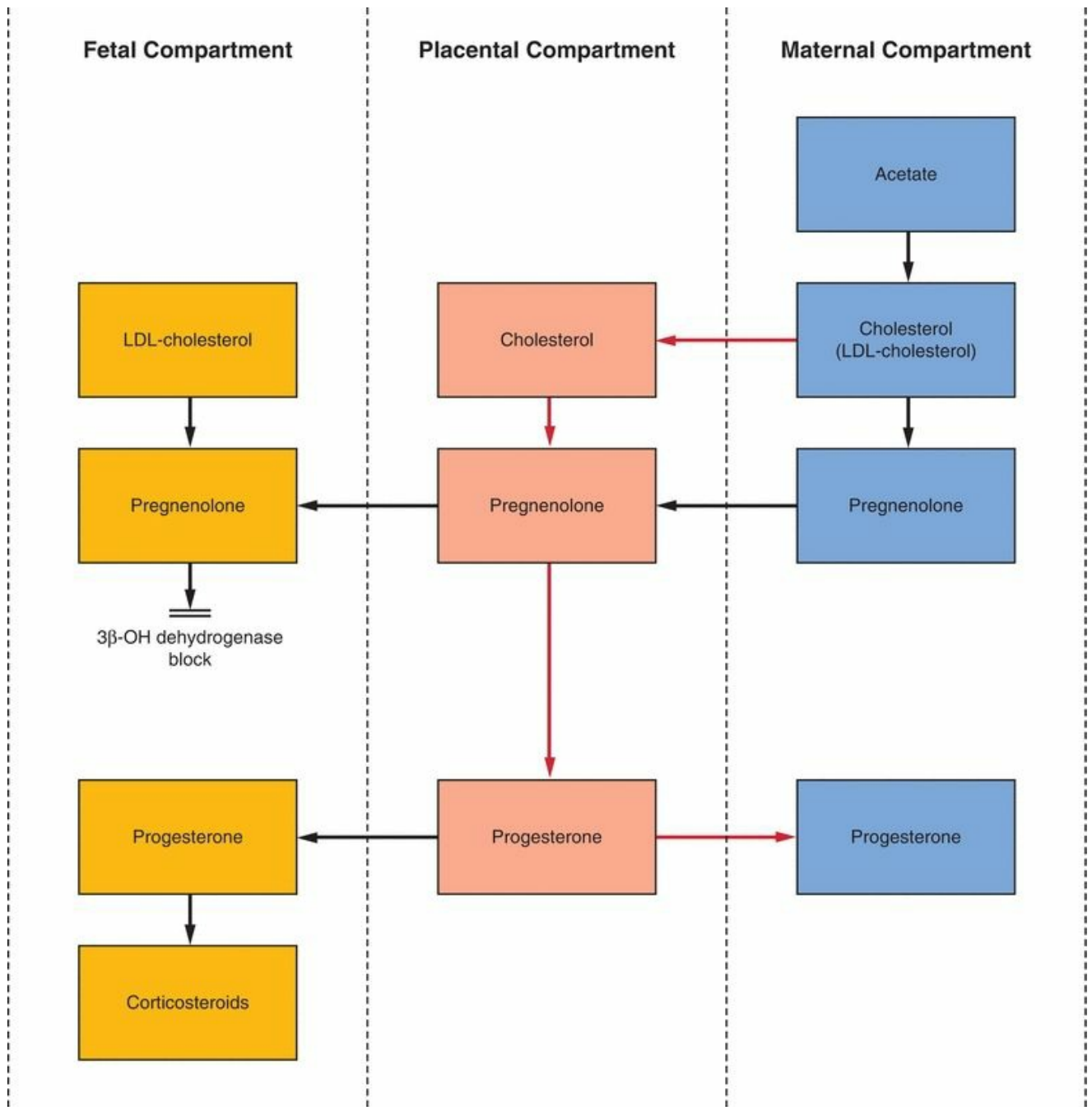
# The Endocrinology of Pregnancy

Who is in charge of pregnancy, the mother or her fetus? From the vantage point of an outsider looking in, it seems as if the mother is in charge. But from the fetal point of view, it is overwhelmingly logical that the maternal adaptations of pregnancy are controlled by the fetus. For the fetus, one of the crucial aspects of intrauterine life is its dependency on the effective exchange of nutritive and metabolic products with the mother. It is logical that mechanisms exist by which a growing fetus can influence or control the exchange process and, hence, its environment. The methods by which a fetus can influence its own growth and development involve a variety of messages transmitted, in many cases, by hormones. Hormonal messengers from the conceptus can affect metabolic processes, uteroplacental blood flow, and cellular differentiation. Furthermore, a fetus may signal its desire and readiness to leave the uterus by hormonal initiation of parturition. On the other hand, from a teleologic standpoint, since pregnancy is such a great biologic investment, it would be logical for the mother to allocate its precious resources focusing on supporting competent embryos. Indeed, it appears that the endometrium acts as a biosensor responding favorably to competent embryos but less favorably to poorly viable embryos, which are destined to fail. This chapter reviews the mechanisms of maternal-conceptus crosstalk and by which the fetus establishes influence over important events during pregnancy. The important process of lactation is discussed in [Chapter 16](#).

# STEROID HORMONES IN PREGNANCY

---

Steroidogenesis in the fetoplacental unit does not follow the conventional mechanisms of hormone production within a single organ. Instead, the final products result from critical interactions and interdependence of separate organ systems that individually do not possess the necessary enzymatic capabilities. It is helpful to view the process as consisting of a fetal compartment, a placental compartment (specifically the syncytiotrophoblast), and a maternal compartment (**Figure 7.1**). Separately, the fetal and placental compartments lack certain steroidogenic activities. Together, however, they are complementary and form a complete unit that utilizes the maternal compartment as a source of basic building materials and as a resource for clearance of steroids.



**FIGURE 7.1**

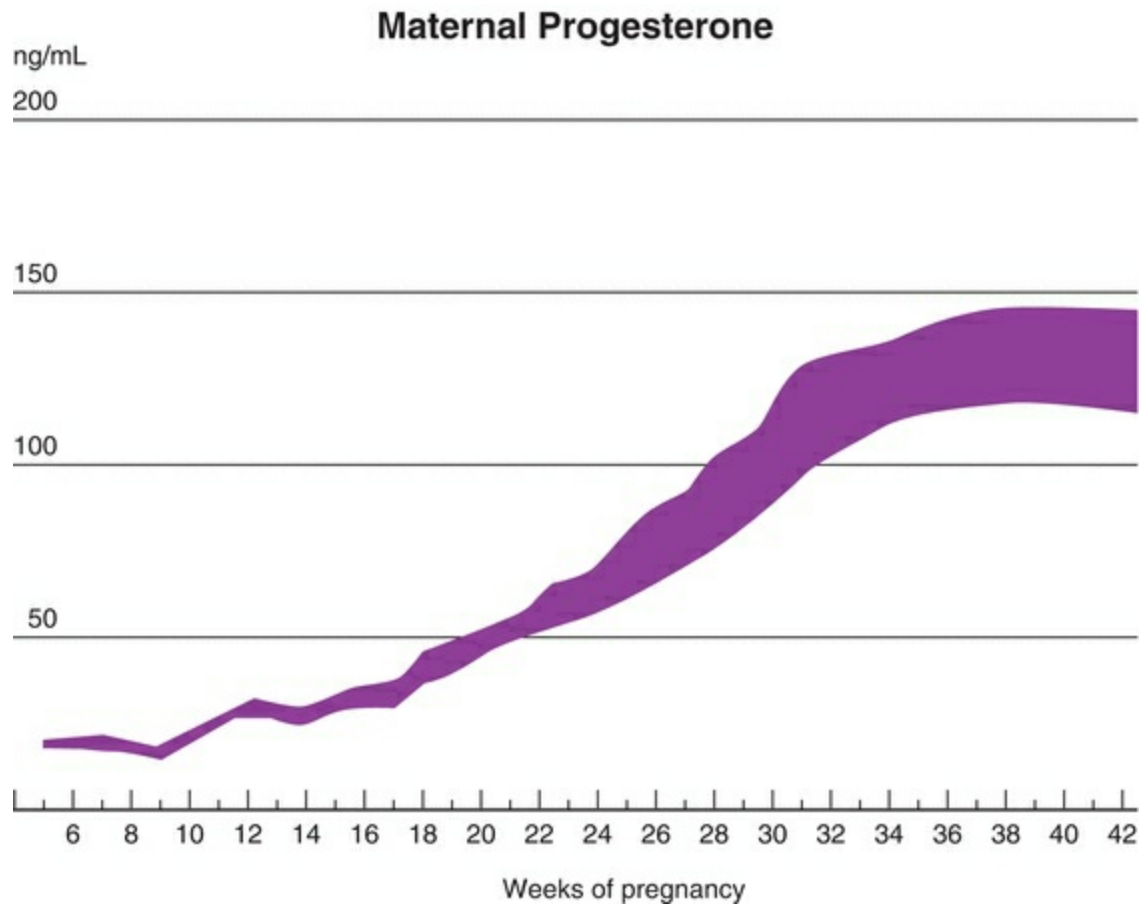
# Progesterone

In its key location as a way station between mother and fetus, the placenta can use precursors from either mother or fetus to circumvent its own deficiencies in enzyme activity. The placenta converts little, if any, acetate to cholesterol or its precursors. Cholesterol and pregnenolone are obtained from the maternal bloodstream for progesterone synthesis. The fetal contribution is negligible because progesterone levels remain high after fetal demise. Thus, the massive amount of progesterone produced in pregnancy depends on placental-maternal cooperation, although some have argued that the fetal liver is an important source of cholesterol (discussed later).

Progesterone is largely produced by the corpus luteum until about 10 weeks of gestation. Pulsatile pituitary luteinizing hormone (LH) and eventually human chorionic gonadotropin (hCG) from the implanting pregnancy stimulate progesterone production by the corpus luteum, which is essential for pregnancy maintenance until approximately the seventh week,<sup>1</sup> when placental progesterone production is sufficient. In the setting of assisted reproductive technologies (ART), luteal phase dysfunction is a common side effect. The exact cause of this is still unclear, but possible explanations include hypothalamic suppression of gonadotropin-releasing hormone (GnRH), pituitary down-regulation or blockade of GnRH receptors, and disruption of granulosa cell mass during oocyte retrieval. Exogenous progesterone administration has been used successfully in IVF to overcome this deficiency, and failure to use progesterone for luteal phase support results in low pregnancy rates between 0% and 18%.<sup>2</sup> While it is clear that progesterone support is needed in patients undergoing ART, there is significant debate regarding the optimal dose, timing, and route of administration.<sup>3</sup> Exogenous support for an early pregnancy (until 10 weeks) requires 100 mg of progesterone daily, associated with a maternal circulating level of approximately 10 ng/mL.<sup>4</sup> Despite this requirement, patients pregnant after ovarian stimulation with one of the techniques of assisted reproductive technology have concluded a successful pregnancy after experiencing extremely low progesterone levels.<sup>5,6</sup> Thus, individual variation is great, and very low circulating levels of progesterone can be encountered occasionally in women who experience normal pregnancies. The predictive value, therefore, of progesterone measurements is limited.

In the luteal phase of conception cycles, progesterone concentrations increase from about 1–2 ng/mL on the day of the LH surge to a plateau of approximately 10–35 ng/mL over the subsequent 7 days. The concentrations remain within this luteal phase range until the placenta takes over. After a transition period of shared function between the 7th week and 10th week called the luteal-placental shift, the placenta emerges as the major source of progesterone synthesis, and maternal circulating levels progressively increase

(Figure 7.2).<sup>4,7,8</sup> At term, progesterone levels range from 100 to 200 ng/mL, and the placenta produces about 250 mg/day. Most of the progesterone produced in the placenta enters the maternal circulation.



**FIGURE 7.2**

In contrast to estrogen, progesterone production by the placenta is largely independent of the quantity of precursor available, the uteroplacental perfusion, fetal well-being, or even the presence of a live fetus. This is because the fetus contributes essentially no precursor. The majority of placental progesterone is derived from maternal cholesterol that is readily available. This is evident as progesterone levels remain high even after fetal demise. At term, a small portion (3%) is derived from maternal pregnenolone.

The cholesterol utilized for progesterone synthesis enters the trophoblast from the maternal bloodstream as low-density lipoprotein (LDL) cholesterol, by means of the process of endocytosis (internalization, as described in Chapter 1) involving the LDL cell membrane receptors, a process enhanced in pregnancy by estrogen (Figure 7.1).<sup>9,10</sup> Hydrolysis of the protein component of LDL may yield amino acids for the fetus, and essential fatty acids may be derived from hydrolysis of the cholesteryl esters. Unlike



steroidogenesis elsewhere, it is not clear whether placental progesterone production requires the control of tropic hormones. Although some evidence suggests that tropic hormone support is not necessary, other evidence indicate that a small amount of hCG must be present.<sup>11,12</sup>

There is evidence in the baboon that estrogen (estradiol) regulates progesterone production in the placenta.<sup>13</sup> The fetoplacental units in human and baboon pregnancies are virtually identical. Estradiol increases LDL cholesterol uptake in baboon trophoblastic tissue by increasing LDL receptor gene transcription, and in human syncytiotrophoblast, estradiol increases progesterone production by means of an increase in LDL uptake.<sup>13,14</sup> Estrogen also stimulates cholesterol production in the human fetal liver to provide circulating LDL cholesterol substrate for steroidogenesis.<sup>15</sup> In addition, estrogen increases placental P450<sub>scc</sub> enzyme activity that converts cholesterol to pregnenolone, the immediate precursor for progesterone. Because estrogen production ultimately depends on the fetal adrenal gland for precursors, the influence of estrogen on progesterone production would be another example of fetal direction and control in the endocrinology of pregnancy. The proponents of this interaction and dependence of progesterone production on fetal precursors argue that the lack of impact by conditions of estrogen deficiency (e.g., anencephaly, fetal demise) on progesterone production is due to the fact that active, unbound estrogen remains within a critical, effective range, and what is lost reflects the degree of excess production in pregnancy.<sup>13</sup>

The human decidua and fetal membranes also synthesize and metabolize progesterone.<sup>16</sup> In this case, neither cholesterol nor LDL cholesterol are significant substrates; pregnenolone sulfate may be the most important precursor. This local steroidogenesis may play a role in regulating parturition.

Amniotic fluid progesterone concentration is maximal between 10 and 20 weeks and then decreases gradually. Myometrial levels are about 3 times higher than maternal plasma levels in early pregnancy, remain high, and are about equal to the maternal plasma concentration at term.

In early pregnancy, the maternal levels of 17 $\alpha$ -hydroxyprogesterone rise, marking the activity of the corpus luteum. By the 10th week of gestation, this compound has returned to baseline levels, indicating that the placenta has little 17 $\alpha$ -hydroxylase activity. However, beginning about the 32nd week, there is a second, more gradual rise in 17 $\alpha$ -hydroxyprogesterone, due to placental utilization of fetal D5-sulfoconjugated precursors, to approximately 7 ng/mL, a level that persists until term.<sup>17</sup>

There are two active metabolites of progesterone that increase significantly during pregnancy. There is about a 10-fold increase of the 5 $\alpha$ -reduced metabolite, 5 $\alpha$ -

pregnane-3-20-dione.<sup>18</sup> This compound contributes to the resistance in pregnancy against the vasopressor action of angiotensin II. The circulating level, however, is the same in normal and hypertensive pregnancies. The maternal blood concentration of deoxycorticosterone (DOC) at term is 1,200 times the nonpregnant levels. Some of this is due to the 3- to 4-fold increase in cortisol-binding globulin during pregnancy, but a significant amount is due to 21-hydroxylation of circulating progesterone in the kidney.<sup>19</sup> This activity is significant during pregnancy because the rate is proportional to the circulating concentration of progesterone. The fetal kidney is also active in 21-hydroxylation of the progesterone secreted by the placenta into the fetal circulation. Currently, there is no known physiologic role for DOC during pregnancy.

Progesterone has a role in parturition as discussed later in this chapter. It has been suggested that progesterone is also important in suppressing the maternal immunologic response to fetal antigens, thereby preventing maternal rejection of the trophoblast. And, of course, progesterone prepares and maintains the endometrium to allow implantation. The human corpus luteum makes significant amounts of estradiol, but it is progesterone and not estrogen that is required for successful implantation.<sup>20</sup> Because implantation normally occurs about 5–6 days after ovulation, and hCG must appear by the 10th day after ovulation to rescue the corpus luteum, the blastocyst must successfully implant and secrete hCG within a narrow window of time. In the first 5–6 weeks of pregnancy, hCG stimulation of the corpus luteum results in the daily secretion of about 25 mg of progesterone and 0.5 mg of estradiol. Although estrogen levels begin to increase at 4–5 weeks due to placental secretion, progesterone production by the placenta does not significantly increase until about 10–11 weeks after ovulation.

Progesterone serves as the substrate for fetal adrenal gland production of glucocorticoids and mineralocorticoids; however, cortisol synthesis is also derived from LDL cholesterol synthesized in the fetal liver and obtained from the fetal circulation.<sup>15,21</sup> The fetal zone in the adrenal gland is extremely active but produces steroids with a  $3\beta$ -hydroxy- $\Delta^5$  configuration like pregnenolone and dehydroepiandrosterone (DHEA), rather than 3-keto- $\Delta^4$  products such as progesterone. The fetus, therefore, lacks significant activity of the  $3\beta$ -C,  $\Delta^{4,5}$  isomerase system. Thus, the fetus must borrow progesterone from the placenta to circumvent this lack in order to synthesize the biologically important corticosteroids. In return, the fetus supplies what the placenta lacks: 19-carbon compounds to serve as precursors for estrogens.

Steroid levels have been compared in maternal blood, fetal blood, and amniotic fluid obtained at fetoscopy in women undergoing termination of pregnancy at 16–20 weeks of gestation.<sup>22</sup> Cortisol, corticosterone, and aldosterone are definitely secreted by the fetal adrenal gland independently of the mother. The fetal arteriovenous differences confirm that placental progesterone is a source for fetal adrenal cortisol and

aldosterone.

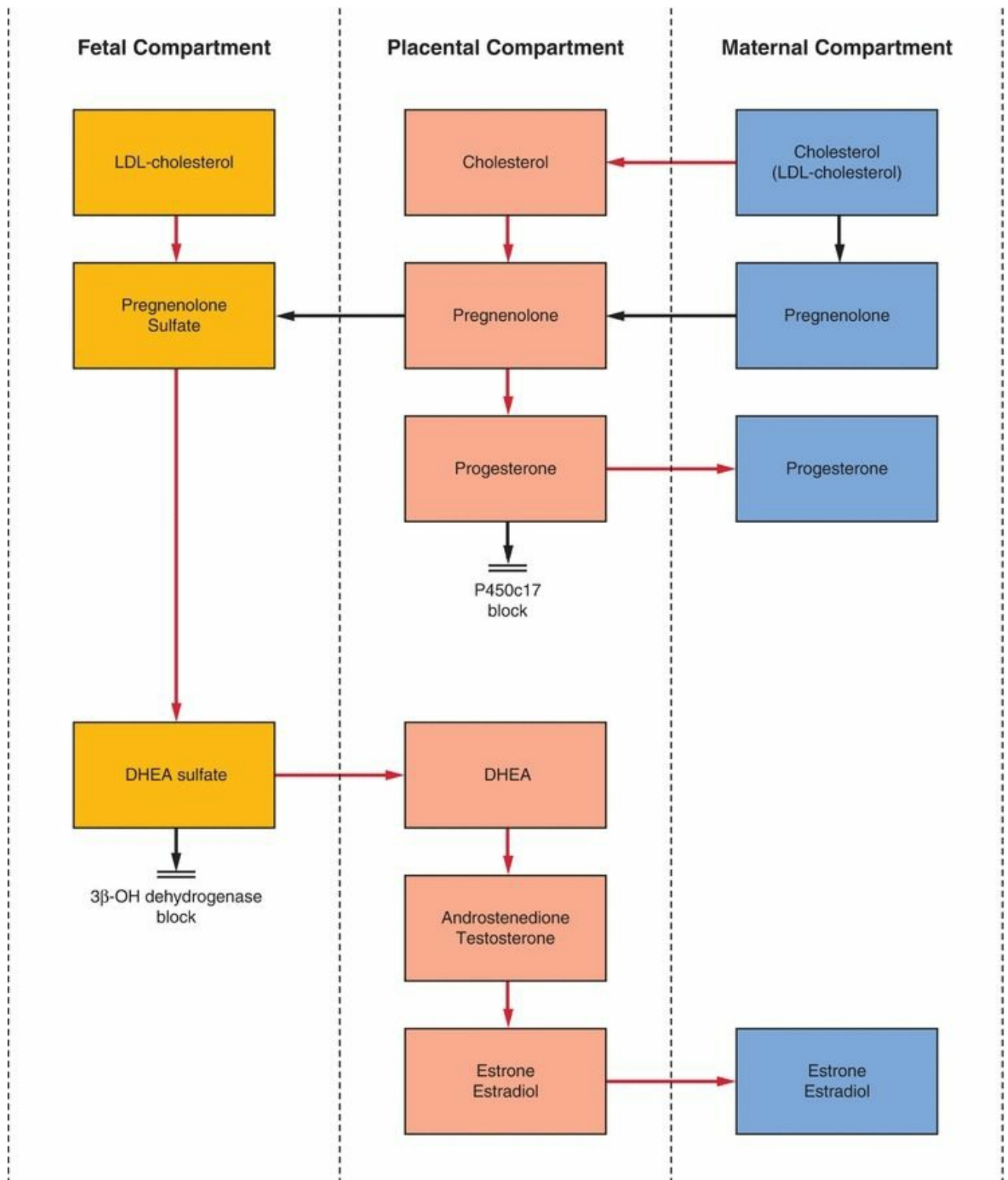
# Estrogens

The corpus luteum is the exclusive source of  $17\beta$ -estradiol during the first 5–6 weeks of gestation. After the first trimester, the placenta becomes the major source of circulating  $17\beta$ -estradiol.<sup>8</sup> Estrogen production in pregnancy is under the control of the fetus and is a fundamental signaling method by which the fetus directs important physiologic processes that affect fetal well-being. Estrogen influences progesterone production, uteroplacental blood flow, mammary gland development, and fetal adrenal gland function.<sup>13</sup>

The basic precursors of estrogens are 19-carbon androgens. However, there is a virtual absence of  $17\alpha$ -hydroxylation and 17,20 desmolase (lyase) activity (P450c17) in the human placenta. As a result, 21-carbon products (progesterone and pregnenolone) cannot be converted to 19-carbon steroids (androstenedione and DHEA). Like progesterone, estrogen produced by the placental aromatase (P450arom) enzyme system must derive precursors from outside the placenta.<sup>23</sup>

The androgen compounds utilized for estrogen synthesis in human pregnancy are, in the early months of gestation, derived from the maternal bloodstream. By the 20th week of pregnancy, the vast majority of estrogen excreted in the maternal urine is derived from fetal androgens. In particular, approximately 90% of estriol excretion can be accounted for by dehydroepiandrosterone sulfate (DHEAS) production by the fetal adrenal gland.<sup>23,24</sup> The high output of DHEAS by the fetal zone is due to low  $3\beta$ -hydroxysteroid dehydrogenase gene expression.<sup>25</sup> Removed from these conditions, this gene becomes active in response to adrenocorticotrophic hormone (ACTH).

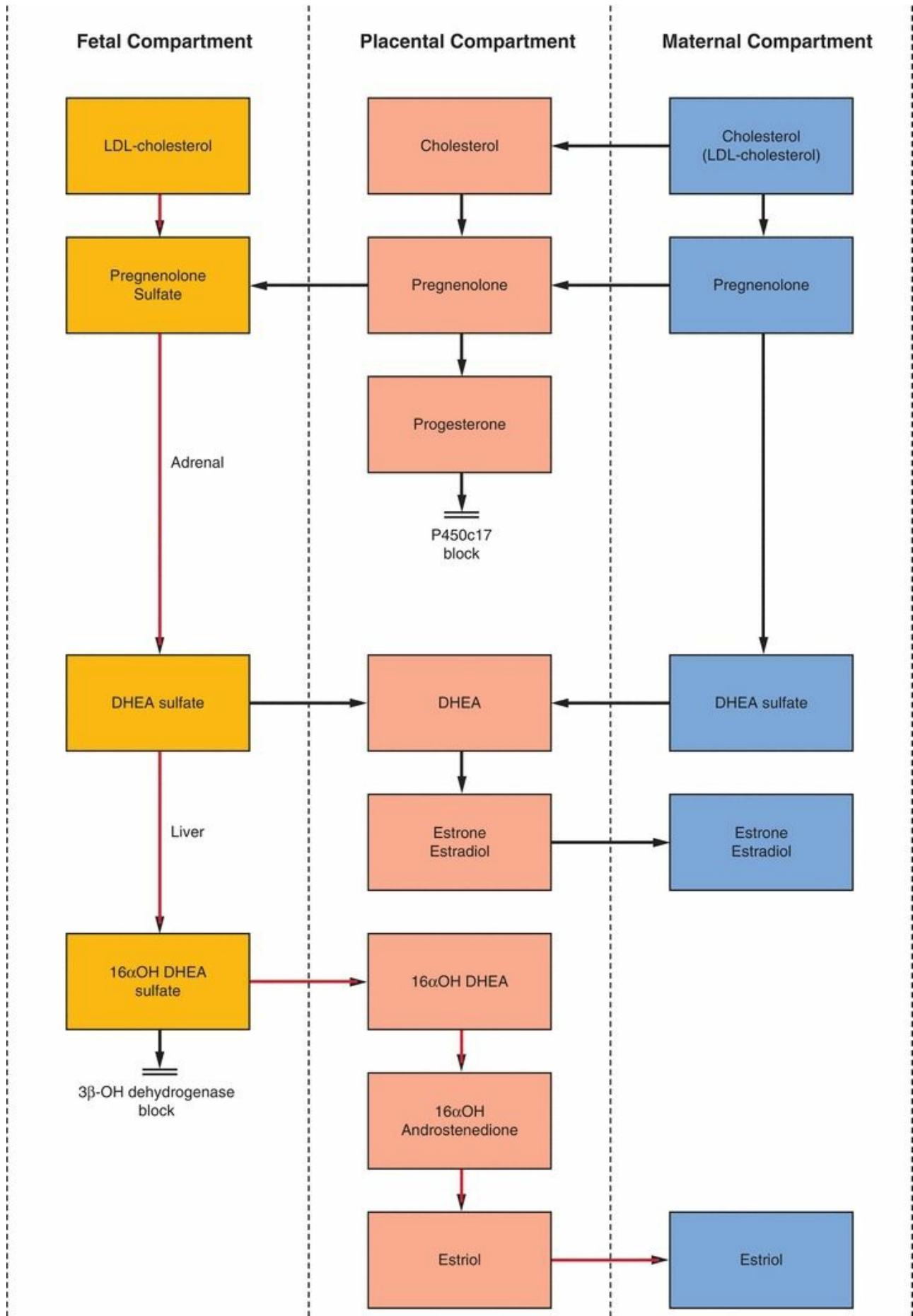
The major source of fetal adrenal DHEAS is LDL cholesterol circulating in the fetal blood. A minor source of fetal adrenal DHEAS is derived from pregnenolone secreted by the placenta. The fetal endocrine compartment is characterized by rapid and extensive conjugation of steroids with sulfate. This is a protective mechanism, blocking the biologic effects of potent steroids present in such great quantities. In order to utilize fetal precursors, the placenta must be extremely efficient in cleaving the sulfate conjugates brought to it via the fetal bloodstream (**Figure 7.3**). Indeed, the sulfatase activity in the placenta is rapid and quantitatively very significant. It is recognized that a deficiency in placental sulfatase is associated with low estrogen excretion, giving clinical importance to this metabolic step. This syndrome is discussed in greater detail later in this chapter.



**FIGURE 7.3**

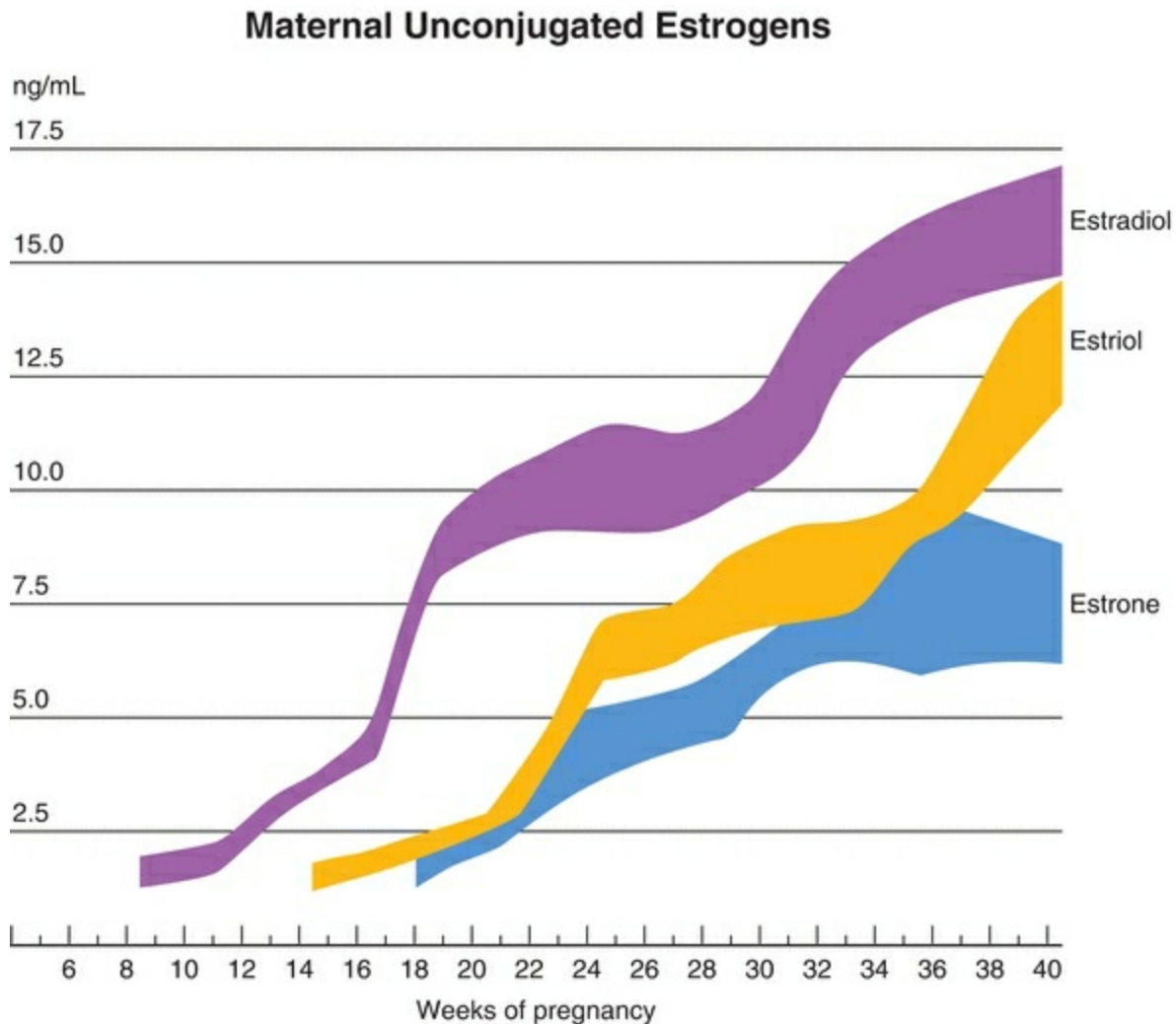
The fetal adrenal provides DHEAS as a precursor for placental production of estrone and estradiol. However, the placenta lacks 16 $\alpha$ -hydroxylation ability, and estriol with its 16 $\alpha$ -hydroxyl group must be derived from an immediate fetal precursor. The fetal

adrenal, with the aid of  $16\alpha$ -hydroxylation in the fetal liver, provides the  $16\alpha$ -hydroxydehydroepiandrosterone sulfate for placental estriol formation (**Figure 7.4**). After birth, neonatal hepatic  $16\alpha$ -hydroxylation activity rapidly disappears. The maternal contribution of DHEAS to total estrogen synthesis must be negligible because, in the absence of normal fetal adrenal glands (as in an anencephalic infant), maternal estrogen levels and excretion are extremely low. The fetal adrenals secrete more than 200 mg of DHEAS daily, about 10 times more than the mother.<sup>26</sup> Estriol is the estrogen produced in greatest quantity during pregnancy; estrone and estradiol are derived equally from fetal and maternal precursors.<sup>24</sup>



## FIGURE 7.4

The profiles of the unconjugated compounds in the maternal compartment for the three major estrogens in pregnancy are as follows (Figure 7.5):



## FIGURE 7.5

1. A rise in estrone begins at 6–10 weeks, and individual values range from 2 to 30 ng/mL at term.<sup>27</sup> This wide range in normal values precludes the use of estrone measurements in clinical applications.
2. A rise in estradiol begins in weeks 6–8 when placental function becomes apparent.<sup>4</sup> Individual estradiol values vary between 6 and 40 ng/mL at 36 weeks of gestation and then undergo an accelerated rate of increase.<sup>27</sup> At



**term, an equal amount of estradiol arises from maternal DHEAS and fetal DHEAS, and its importance in fetal monitoring is negligible.**

- 3. Estriol is first detectable at 9 weeks when the fetal adrenal gland secretion of precursor begins. This temporal relationship closely corresponds to the early stages of steroidogenic maturation in the fetal adrenal cortex, and the continued production of estriol is dependent upon the presence of a living fetus. Estriol is first detectable at approximately 0.05 ng/mL by 9 weeks and steadily increases to a range of approximately 10–30 ng/mL at term. Estriol concentrations plateau at 31–35 weeks and then increase again at 35–36 weeks.**<sup>28</sup>

During pregnancy, estrone and estradiol production is increased about 100 times over nonpregnant levels. However, the increase in maternal estriol excretion is about a 1,000-fold. The traditional view that estriol in pregnancy is a weak estrogen metabolite is not accurate. A weak estrogen provided in high concentrations can produce a biologic response equivalent to that of estradiol.<sup>29</sup> Because of its high production rate and concentration, estriol is an important hormone in pregnancy. The maternal level of estradiol is higher than in the fetus; in contrast, the estriol level in the fetus is greater than in the mother.

The maternal cardiovascular adaptations to pregnancy that are so necessary to serve the fetus are appropriately under the influence of the fetus and significantly regulated by estrogen.<sup>30</sup> Blood volume is increased by estrogen stimulation of the maternal and trophoblastic renin-angiotensin systems, and uteroplacental blood flow, which is so critical for the fetus, is influenced by the vasodilatory effects of estrogen.

The enzyme responsible for estrogen synthesis is the cytochrome P-450 aromatase enzyme (P450arom or aromatase), the product of the CYP19 gene.<sup>31</sup> The CYP19 gene is regulated in various tissues by tissue-specific promoters. The placenta, with its huge capacity for estrogen synthesis, triggers aromatase transcription from a powerful unique promoter that allows specific regulation. An autosomal recessive disorder due to mutations in the P450arom gene is associated with a failure to convert androgen precursors to estrogen by placental aromatase.<sup>32</sup> Consequently, a female fetus and the mother can undergo virilization. Nevertheless, growth and development of the fetus are not impaired, and this disorder raises the question: How much, if any, estrogen is essential in human pregnancy? Is this another example of backup mechanisms operating to achieve the goal?

Normally, placental aromatization is so efficient that little androgen presented to the placenta escapes.<sup>33</sup> For this reason, fetuses are well protected against masculinization, and even in the presence of an androgen-secreting tumor, extremely large amounts of

aromatizable androgens or the secretion of nonaromatizable androgens is required to produce unwanted virilization.

The estrogens presented to the maternal bloodstream are rapidly metabolized by the maternal liver prior to excretion into the maternal urine as a variety of more than 20 products. The bulk of these maternal urinary estrogens is composed of glucosiduronates conjugated at the 16 position. Significant amounts of the 3-glucosiduronate and the 3-sulfate-16-glucosiduronate are also excreted. Only approximately 8–10% of the maternal blood estriol is unconjugated.

# The Fetal Adrenal Cortex

The fetal adrenal cortex is unique, differentiating by 8–9 weeks of gestational age into a thick inner fetal zone and a thin outer definitive zone, which is the source of cortisol and the forerunner of the adult cortex.<sup>34</sup> Early in pregnancy, adrenal growth and development are remarkable, and the gland achieves a size equal to or larger than that of the kidney by the end of the first trimester. After 20–24 weeks, the adrenal glands slowly decrease in size until a second spurt in growth begins at about 34–35 weeks. The gland remains proportionately larger than the adult adrenal glands. After delivery, the fetal zone (about 85% of the bulk of the gland) rapidly involutes to be replaced by simultaneous expansion of the outer definitive zone to form the zona glomerulosa and the transitional zone to form the zona fasciculata and the zona reticularis (which expands again during adrenarche at puberty). By age 1, the fetal zone is gone, replaced by the adult adrenal cortex. Thus, the specific steroidogenic characteristics of the fetus are associated with a specific adrenal morphology that is dependent on specific factors present during intrauterine life.

Fetal DHEA and DHEAS production rises steadily concomitant with the increase in the size of the fetal zone and adrenal weight.<sup>35</sup> DHEA and DHEAS are the major secretory products of the fetal zone because  $3\beta$ -hydroxysteroid dehydrogenase-isomerase activity and the expression of this enzyme's gene are suppressed.<sup>25,36</sup> The well-known increase in maternal estrogen levels is significantly influenced by the increased availability of fetal DHEAS as a precursor. Indeed, the accelerated rise in maternal estrogen levels near term can be explained, in part, by an increase in fetal DHEAS. The stimulus for the substantial adrenal growth and steroid production has been a puzzle.

Early in pregnancy, the adrenal gland can grow and function without ACTH, perhaps in response to hCG.<sup>34</sup> After 15–20 weeks, fetal ACTH is required. However, during the last 12–14 weeks of pregnancy when fetal ACTH levels are declining, the adrenal quadruples in size.<sup>37</sup> Because pituitary prolactin is the only fetal pituitary hormone to increase throughout pregnancy, paralleling fetal adrenal gland size changes, it was proposed that fetal prolactin is the critical tropic substance. In experimental preparations, however, only ACTH exerts a steroidogenic effect. There is no fetal adrenal response to prolactin, hCG, growth hormone, melanocyte-stimulating hormone (MSH), or thyrotropin-releasing hormone (TRH).<sup>38,39</sup> Furthermore, in patients treated with bromocriptine, fetal blood prolactin levels are suppressed, but DHEAS levels are unchanged.<sup>40</sup> Nevertheless, interest in prolactin persists because both ACTH and prolactin can stimulate steroidogenesis *in vivo* in the fetal baboon.<sup>41</sup>

There is no question that, in the second half of pregnancy, ACTH is essential for the

morphologic development and the steroidogenic mechanism of the fetal adrenal gland.<sup>42,43</sup> ACTH activates adenylate cyclase, leading to steroidogenesis. Soon, the supply of cholesterol becomes rate limiting. Further ACTH action results in an increase in LDL receptors, leading to an increased uptake of circulating LDL cholesterol, largely derived from the fetal liver.<sup>21</sup> With internalization of LDL cholesterol, hydrolysis by lysosomal enzymes of the cholesteryl ester makes cholesterol available for steroidogenesis. For this reason, fetal plasma levels of LDL are low, and after birth, newborn levels of LDL rise as the fetal adrenal involutes. In the presence of low levels of LDL cholesterol, the fetal adrenal is capable of synthesizing cholesterol de novo.<sup>44</sup> Thus, near term, both de novo synthesis and utilization of circulating LDL cholesterol are necessary to sustain the high rates of DHEAS and estrogen formation. In addition, ACTH increases adrenal response by increasing the expression of its own receptor.<sup>45</sup>

The tropic support of the fetal adrenal gland by ACTH from the fetal pituitary is protected by placental estrogen. The placenta prevents cortisol that is present in higher levels in the mother from reaching the fetus by converting cortisol to cortisone. The converting enzyme, 11 $\beta$ -hydroxysteroid dehydrogenase, is abundantly expressed in syncytiotrophoblast at the interface between fetal tissue and maternal blood and is stimulated by placental estrogen.<sup>46,47</sup> Regulation of this enzyme by estrogen thus influences fetal ACTH secretion. With increasing estrogen levels in late gestation, even greater 11 $\beta$ -hydroxysteroid dehydrogenase activity would result in even less maternal cortisol reaching the fetal circulation. Thus, it is proposed that near labor, fetal ACTH secretion increases, the fetal adrenal gland undergoes greater maturation, and fetal cortisol synthesis from endogenous cholesterol increases.<sup>48</sup> A relative deficiency in 11 $\beta$ -hydroxysteroid dehydrogenase type 2 (the high-affinity isoform) would expose the fetus to excessively high cortisol levels and is correlated with low birth weight, which in turn is correlated with insulin resistance, abnormal lipids, and hypertension in adult life.<sup>49,50,51</sup> A reduction of type 2 11 $\beta$ -hydroxysteroid dehydrogenase activity has been reported in pregnancies complicated by smoking and pre-eclampsia, conditions known to be associated with intrauterine growth retardation.<sup>52,53</sup> A similar reduction in activity has been documented with idiopathic intrauterine growth retardation, accompanied by a decreased ratio of cortisone to cortisol in umbilical artery blood.<sup>51</sup>

An interaction has been demonstrated in vitro between progesterone and the lipoxygenase pathways that lead to the products of arachidonic acid other than prostaglandins in regard to the regulation of 11 $\beta$ -hydroxysteroid dehydrogenase activity.<sup>54</sup> Progesterone down-regulates 11 $\beta$ -hydroxysteroid dehydrogenase expression, as do the products of lipoxygenase activity. Because the lipoxygenase products increase progesterone output by trophoblast cells, an increase in lipoxygenase activity because of infection could increase progesterone levels, which in turn would decrease 11 $\beta$ -

hydroxysteroid dehydrogenase activity, resulting in higher cortisol levels in the fetus with the consequences of stress and growth retardation.

It has been suggested that the increase in fetal cortisol secretion during normal pregnancy competes with progesterone for the glucocorticoid receptor in the placenta, thus blocking the inhibitory action of progesterone on corticotropin-releasing hormone (CRH) synthesis, leading to an increase in CRH.<sup>55</sup> Placental production of CRH and the size of the fetal adrenal gland are closely correlated in several primates, both reaching a peak in humans at the time of parturition. The increase in CRH would augment fetal ACTH secretion, producing adrenal growth and even more fetal cortisol in a positive feedback relationship, as well as more DHEAS to serve as precursor for the increase in estrogen that occurs prior to parturition. However, fetal ACTH levels in the last half of pregnancy are not increasing but slightly decreasing. It is significant that CRH, as demonstrated in vitro, also directly stimulates DHEAS synthesis by the fetal adrenal gland.<sup>56,57</sup>

This is an important fetoplacental-adrenal cycle. Cortisol from the adrenal gland increases placental CRH production; CRH induces ACTH receptor expression in the definitive zone of the fetal adrenal gland, leading to even greater adrenal cortisol secretion, and that in turn increases placental CRH biosynthesis as gestation advances.<sup>58</sup> Direct stimulation of the fetal zone by CRH, supported by the presence of ACTH, augments the increasing production of DHEA and DHEAS required for estrogen synthesis in late gestation.<sup>57</sup>

Adrenal gland steroidogenesis involves autocrine and paracrine regulation by various growth factors.<sup>34</sup> Fetal adrenal cells produce inhibin, and the  $\alpha$  subunit (present only in inhibin) is preferentially increased by ACTH.<sup>59,60</sup> In the fetal adrenal, the  $\beta$  subunit is not expressed; thus, inhibin-A and activin-A are the principal forms.

Activin enhances ACTH-stimulated steroidogenesis while inhibiting mitogenesis in human fetal zone adrenal cells.<sup>60</sup> This effect on steroidogenic activity is not present in adult adrenal cells. In vitro, activin enhances a shift in fetal adrenal cells from ACTH stimulation of DHEAS production to cortisol production. This shift is analogous to the shift that occurs after birth. Perhaps, activin plays this role in the remodeling of the fetal zone in the newborn. A specific action for inhibin in fetal adrenal cells has not been described.

We should not expect the fetal adrenal gland to be an exception to the ubiquitous presence and actions of all growth factors.<sup>34</sup> Basic fibroblast growth factor has potent mitogenic activity mediating the growth response of the fetal adrenal cortex to ACTH. Evidence indicates that the epidermal growth factor (EGF) receptor is activated in the fetal adrenal, but the ligand using this receptor is probably transforming growth factor-

$\alpha$ . Like activin, transforming growth factor- $\beta$  inhibits fetal zone cellular proliferation and, in addition, suppresses steroidogenesis.

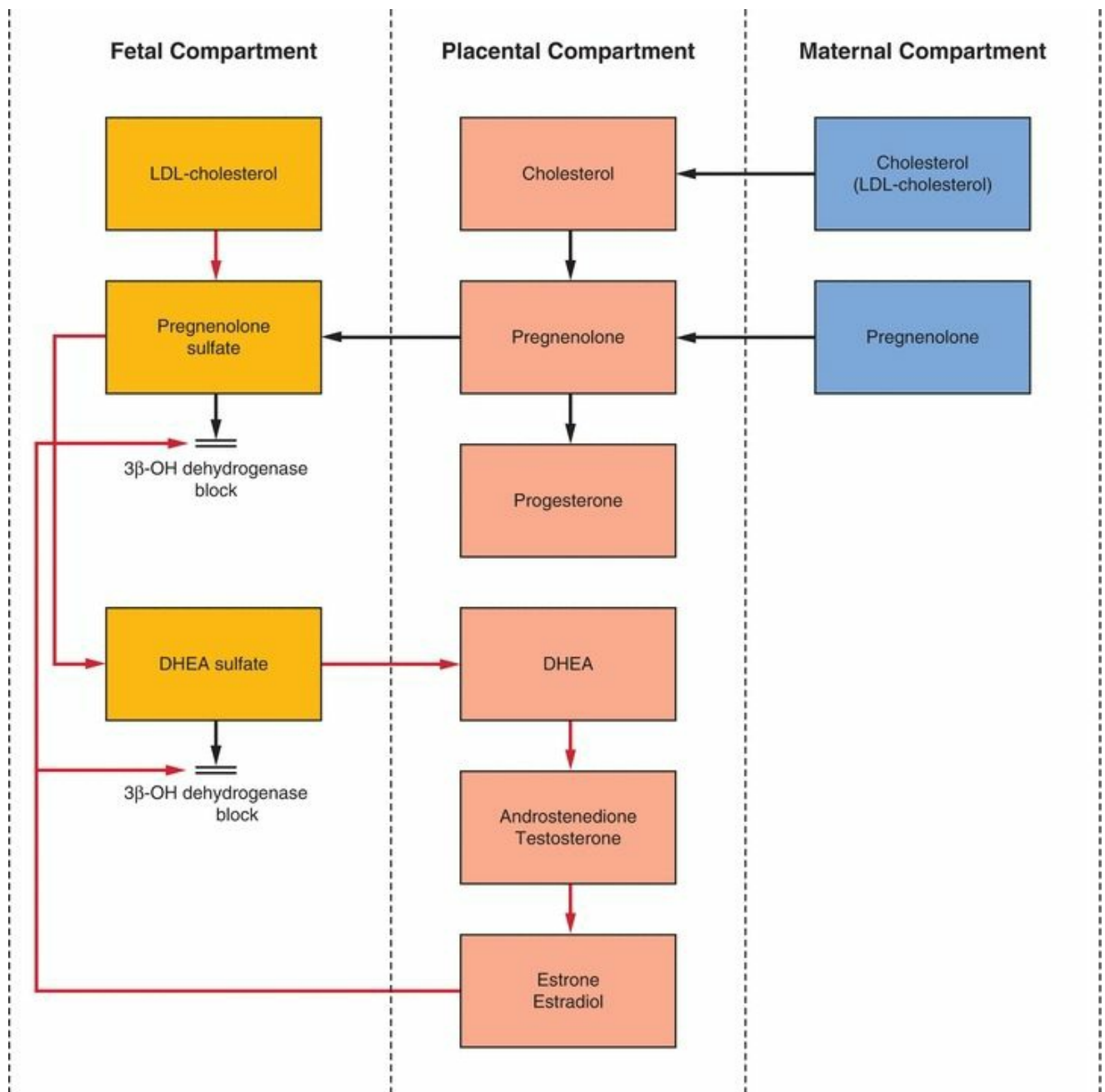
The insulin-like growth factors (IGF-I and IGF-II) are important in mediating the tropic effects of ACTH, particularly increasing adrenal responsiveness to ACTH in the second half of pregnancy.<sup>61</sup> IGF-II production in the fetal adrenal is very significant and is stimulated by ACTH. IGF-II is believed to be important in prenatal growth.<sup>62</sup> The abundance of IGF-II in the fetal adrenal gland implicates this growth factor as a mediator of ACTH-induced growth.<sup>63</sup> Both IGF-I and IGF-II are equally mitogenic in a cell culture system of fetal adrenal cells and enhance the proliferation stimulated by basic fibroblast growth factor and EGF.<sup>63</sup> However, only transcription of IGF-II is stimulated by ACTH. IGF-II augments ACTH-stimulated steroidogenesis in the fetal adrenal, specifically by increasing the expression of P450c17.<sup>61</sup> Thus, the growth-promoting and steroidogenic effects of ACTH are mediated by various growth factors, with a principal role played by IGF-II. In this regard, the fetal adrenal differs from the adult adrenal where IGF-I is predominant; however, IGF-II is able to modulate responsiveness to ACTH in the fetal adrenal by activating the IGF-I receptor.

Steroidogenic factor-1 (SF-1) and DAX-1 (named for the location of its gene on the X chromosome) are nuclear receptors for which specific ligands have not been identified (“orphan receptors”). SF-1 influences the expression of genes that encode steroidogenic enzymes, and when genetic expression of SF-1 is disrupted in mice, gonads and adrenal glands fail to develop.<sup>64,65</sup> Mutations in the DAX-1 gene result in adrenal hypoplasia, and DAX-1 is believed to work with SF-1 in regulating development and function of steroid-producing tissues.<sup>66</sup>

The production of DHEA is dependent on the CYP17 gene that is responsible for both 17 $\alpha$ -hydroxylase and 17,20-lyase enzyme activity. Differential regulation of these two activities with an increase in 17,20-lyase could account for the increase in DHEA in the fetal zone of the adrenal gland. The SULT2A1 gene is responsible for the sulfation and production of DHEAS. Modulation of this gene would also contribute to the steroidogenic activity of the fetal zone.

The unique features of the fetal adrenal gland can be ascribed to its high-estrogen environment. Tissue culture studies have demonstrated that hormonal peptides of pituitary or placental origin are not the factors that are responsible for the behavior of the fetal adrenal gland.<sup>67,68,69</sup> Estrogens at high concentration inhibit 3 $\beta$ -hydroxysteroid dehydrogenase-isomerase activity in the fetal adrenal gland and, in the presence of ACTH in conjunction with IGF-II, enhance the secretion of DHEA.<sup>70</sup> Estradiol concentrations of 10–100 ng/mL are required to inhibit cortisol secretion.<sup>71</sup> The total estrogen concentrations in the fetus are easily in this range (**Figure 7.5**). A study of the

kinetics of  $3\beta$ -hydroxysteroid dehydrogenase activity in human adrenal microsomes reveals that all steroids are inhibitory and, most notably, estrone and estradiol at levels found in fetal life cause almost total inhibition.<sup>72</sup> In a study utilizing a human adrenocortical cell line, estradiol in high concentrations inhibited  $3\beta$ -hydroxysteroid dehydrogenase, and the mechanism appeared to be independent of the estrogen receptor.<sup>73</sup> The increase in DHEAS secretion by the fetal zone is a consequence of suppression of the gene (HSD3B2) that controls  $3\beta$ -hydroxysteroid dehydrogenase expression; transcriptional factors necessary for the activity of this gene are absent in the fetal zone (Figure 7.6).<sup>74</sup>



## FIGURE 7.6

The development of the adrenal gland during human fetal life and during the neonatal period is paralleled in the baboon.<sup>75</sup> The adrenal cortex of the fetal baboon is characterized by the same deficiency in  $3\beta$ -hydroxysteroid dehydrogenase as that seen in the human, with the same diversion of steroidogenesis into production of DHEA and DHEAS. Experimental studies in the baboon suggest that placental estrogen maintains the production of DHEA and DHEAS by the fetal adrenal cortex, but excessive adrenal growth and steroidogenesis are at the same time suppressed by the increasing estrogen levels in late pregnancy.<sup>76,77</sup>

Tissue growth in mammals is a consequence of cellular proliferation promoted by the cell regulators, cyclin D1 and cyclin E, which dimerize with kinases to form enzymes that carry out key phosphorylations during cell cycles. These key regulators are expressed in increasingly high concentrations in the baboon fetal adrenal cortex, beginning in early gestation to midgestation, especially in the outer definitive zone (destined to be the adult adrenal cortex and the source of cortisol).<sup>78</sup> This early increase in the definitive zone is followed by a progressive decrease in these factors required for cellular proliferation in the definitive zone in late gestation. The cells in the fetal zone are derived from the definitive zone, and these changes indicate that the continued growth of the fetal adrenal cortex during gestation predominantly reflects cellular hypertrophy. Furthermore, because there is a progressive increase in the expression of  $3\beta$ -hydroxysteroid dehydrogenase within the fetal definitive zone, the decline in proliferation is associated with functional differentiation as the definitive zone acquires the ability to produce mineralocorticoids and glucocorticoids.<sup>78</sup> Here again, the key modulator of this change may be estrogen, specifically an estrogen-induced decrease in cyclin expression with advancing gestation.

The explanation that estrogen regulates  $3\beta$ -hydroxysteroid dehydrogenase is challenged by in vitro studies of human fetal zone cells indicating that estradiol and IGF-II combine to direct steroidogenesis to DHEAS in a mechanism not due to inhibition of  $3\beta$ -hydroxysteroid dehydrogenase.<sup>70</sup> **Nevertheless, it is an attractive and useful hypothesis to view the principal mission of the fetal adrenal as providing DHEAS as the basic precursor for placental estrogen production. Estrogen, in turn, feeds back to the adrenal to direct steroidogenesis along the  $\Delta^5$  pathway to provide even more of its precursor, DHEAS. Thus far, this is the only known function of DHEAS. With birth and loss of exposure to estrogen, the fetal adrenal gland quickly changes to the adult type of gland. It seems reasonable to conclude that this complex change in the fetal adrenal cortex is orchestrated by the interplay**



**among fetal pituitary ACTH, placental estrogen, and placental growth factors (PLGFs).**

# Measurement of Estrogen in Pregnancy

Because pregnancy is characterized by a great increase in maternal estrogen levels and estrogen production is dependent on fetal and placental steroidogenic cooperation, the amount of estrogen present in the maternal blood or urine reflects both fetal and placental enzymatic capability and, hence, well-being. Attention focused on estriol because 90% of maternal estriol is derived from fetal precursors. The end product to be assayed in the maternal blood or urine is influenced by a multitude of factors. Availability of precursor from the fetal adrenal gland is a prime requisite, as well as the ability of the placenta to perform its conversion steps. Maternal metabolism of the product and the efficiency of maternal renal excretion of the product can modify the daily amount of estrogen in the urine. Blood flow to any of the key organs in the fetus, placenta, and mother becomes important.<sup>79,80</sup> Fetal hypoxemia due to acute reductions in uteroplacental blood flow is associated with a marked increase in adrenal androgen production in response to an increase in fetal ACTH and, in response to the availability of androgen precursors, an increase in maternal estrogen levels.<sup>81</sup> The response to acute stress is in contrast to the effect of chronic uteroplacental insufficiency, which is associated with a reduction in fetal androgens and maternal estrogens. In addition, drugs or diseases can affect any level in the cascade of events leading up to the assay of estrogen.

For years, measurement of estrogen in a 24-hour urine collection was the standard hormonal method of assessing fetal well-being. This was replaced by immunoassay of unconjugated estriol in the plasma.<sup>82</sup> Because of its short half-life (5–10 minutes) in the maternal circulation, unconjugated estriol has less variation than urinary or total blood estriol. However, assessment of maternal estriol levels has been superseded by various biophysical fetal monitoring techniques such as nonstress testing, stress testing, and measurement of fetal breathing and activity. In recent times, screening for fetal aneuploidy (discussed later in the chapter) utilized three markers in the maternal circulation:  $\alpha$ -fetoprotein, hCG, and unconjugated estriol. Hormonal testing for aneuploidy screening has been largely replaced by cell-free DNA (cfDNA) testing.

## Amniotic Fluid Estrogen Measurements

Amniotic fluid estriol is correlated with the fetal estrogen pattern rather than the maternal. Most of the estriol in the amniotic fluid is present as 16-glucosiduronate or as 3-sulfate-16-glucosiduronate. A small amount exists as 3-sulfate. Very little unconjugated estriol is present in the amniotic fluid because free estriol is rapidly transferred across the placenta and membranes. Estriol sulfate is low in concentration because the placenta and fetal membranes hydrolyze the sulfated conjugates, and the free estriol is then passed out of the fluid. Because the membranes and the placenta have no

glucuronidase activity, the glucosiduronate conjugates are removed slowly from the fetus. The glucosiduronates, therefore, predominate in the fetal urine and the amniotic fluid. Because of the slow changes in glucosiduronates, measurements of amniotic fluid estriol have wide variations in both normal and abnormal pregnancies. An important clinical use for amniotic fluid estrogen measurements has not emerged.

## **Estetrol**

Estetrol (15 $\alpha$ -hydroxyestriol) is formed from a fetal precursor and is very dependent on 15 $\alpha$ -hydroxylation activity in the fetal liver. The capacity for 15 $\alpha$ -hydroxylation of estrogens increases during fetal life, reaching a maximum at term. This activity then declines during infancy and is low, absent, or undetectable in adults. Estetrol may contribute to the estrogen effects taking place during pregnancy as maternal estetrol levels steadily increase with advancing gestation and fetal levels are higher than maternal levels.<sup>83</sup> Because of wide variations within and between individuals, there is no clinical use for maternal blood or urine estetrol measurements during pregnancy. However, estetrol, given in sufficient doses, is a potent, orally active estrogen that has potential for pharmacologic therapy.<sup>84</sup>

# Placental Sulfatase Deficiency

Steroid sulfatase (STS) is a key enzyme in the biosynthesis of estriol in the human placenta. There is an X-linked metabolic disease characterized by a **placental sulfatase deficiency** in the syncytiotrophoblast and postnatal ichthyosis (also known as X-linked ichthyosis or XLI), occurring in about 1 in 2,000–3,000 newborn males.<sup>85</sup> Patients with the placental sulfatase disorder are unable to hydrolyze DHEAS or 16 $\alpha$ -hydroxy-DHEAS; therefore, the placenta cannot form normal amounts of estrogen. A deficiency in placental sulfatase is usually discovered when patients go beyond term and are found to have extremely low estriol levels and no evidence of fetal distress. The patients usually fail to go into labor and require delivery by cesarean section. Most striking is the failure of cervical softening and dilation; thus, cervical dystocia occurs that is resistant to oxytocin stimulation. There are many case reports of this deficiency, almost all detected by finding low estriol levels. It was suggested that mothers who are carriers of this disorder are at increased risk for intrauterine growth retardation and perinatal complications even if the fetus is not affected.<sup>86</sup> However, a careful analysis of unexplained low estriol levels concluded that this is a rare occurrence (about 3 per 10,000 pregnancies) and that perinatal complications in pregnancies at risk for placental sulfatase deficiency are not increased (other than a higher cesarean section rate).<sup>87</sup> XLI is inherited in X-linked recessive manner, therefore affecting almost exclusively males. However, rare cases of XLI were described in females homozygous for STS gene mutation.<sup>88,89</sup> The STS X-linked recessive ichthyosis locus (the STS gene) has been mapped to the distal short arm portion of the X chromosome, Xp22.32. Ninety percent of the cases of ichthyosis have a complete deletion of this gene plus flanking genes, and approximately 10% of patients have a point mutation or partial deletion of the STS gene. There are no known geographic or racial factors that affect the gene frequency. The characteristic steroid findings are as follows: extremely low estriol and estetrol levels in the mother with extremely high amniotic fluid DHEAS and normal amniotic fluid DHEA and androstenedione. The normal DHEA and androstenedione with a high DHEAS rule out congenital adrenal hyperplasia. The small amount of estriol that is present in these patients probably arises from 16 $\alpha$ -hydroxylation of DHEAS in the maternal liver, thus providing 16 $\alpha$ -hydroxylated DHEA to the placenta for aromatization to estriol. Maternal estrone and estradiol are also low but not as markedly reduced because of their utilization of maternal precursors. Measurement in maternal urine of steroids derived from fetal sulfated compounds is a simple and reliable means of prenatal diagnosis. Demonstration of a high level of DHEAS in the amniotic fluid is confirmatory. The diagnosis was established by demonstrating a decrease in sulfatase activity in an in vitro incubation of placental tissue. The clinician should keep in mind that fresh tissue is needed for this procedure because freezing lowers enzyme activity.

STS activity can be assayed in leukocytes and modern diagnosis is done by genetic testing of the STS gene.

It is now recognized that STS deficiency is present in other tissues and can persist after birth. These children develop ichthyosis beginning between birth and 6 months of age, characterized by hyperkeratosis (producing scales on the neck, trunk, and palms) and associated with mild corneal opacities, pyloric stenosis, and cryptorchidism. The skin fibroblasts have a low activity of STS, and scale formation that occurs early in the first year of life is thought to be due to an alteration in the cholesterol:cholesteryl ester ratio (due to the accumulation of cholesterol sulfate). This inherited disorder, thus, represents a single entity: placental sulfatase deficiency and X-linked ichthyosis, both reflecting a deficiency of microsomal sulfatase. More extensive deletions include contiguous genes and result in attention deficit hyperactivity disorder, autism, and mental retardation.<sup>90</sup>

A family history of scaling in males (as well as repeated postdate pregnancies and cesarean sections) should prompt a consideration for prenatal diagnosis. Because the clinical use of estriol measurements has declined, there is no effective method to identify the presence of this problem in women with normal obstetrical histories. However, a low maternal level of unconjugated estriol can be encountered with multiple marker screening (discussed later in this chapter). Furthermore, consideration should be given to antenatal screening by estriol measurement in pregnancies in which a male fetus is present and there is a previous history of a growth-retarded or stillborn male. However, perinatal outcome is good even when placental sulfatase deficiency is not known to be present and only a very small number of affected boys have serious manifestations of the disorder; therefore, it is difficult to justify the need for antenatal diagnosis.<sup>87</sup>

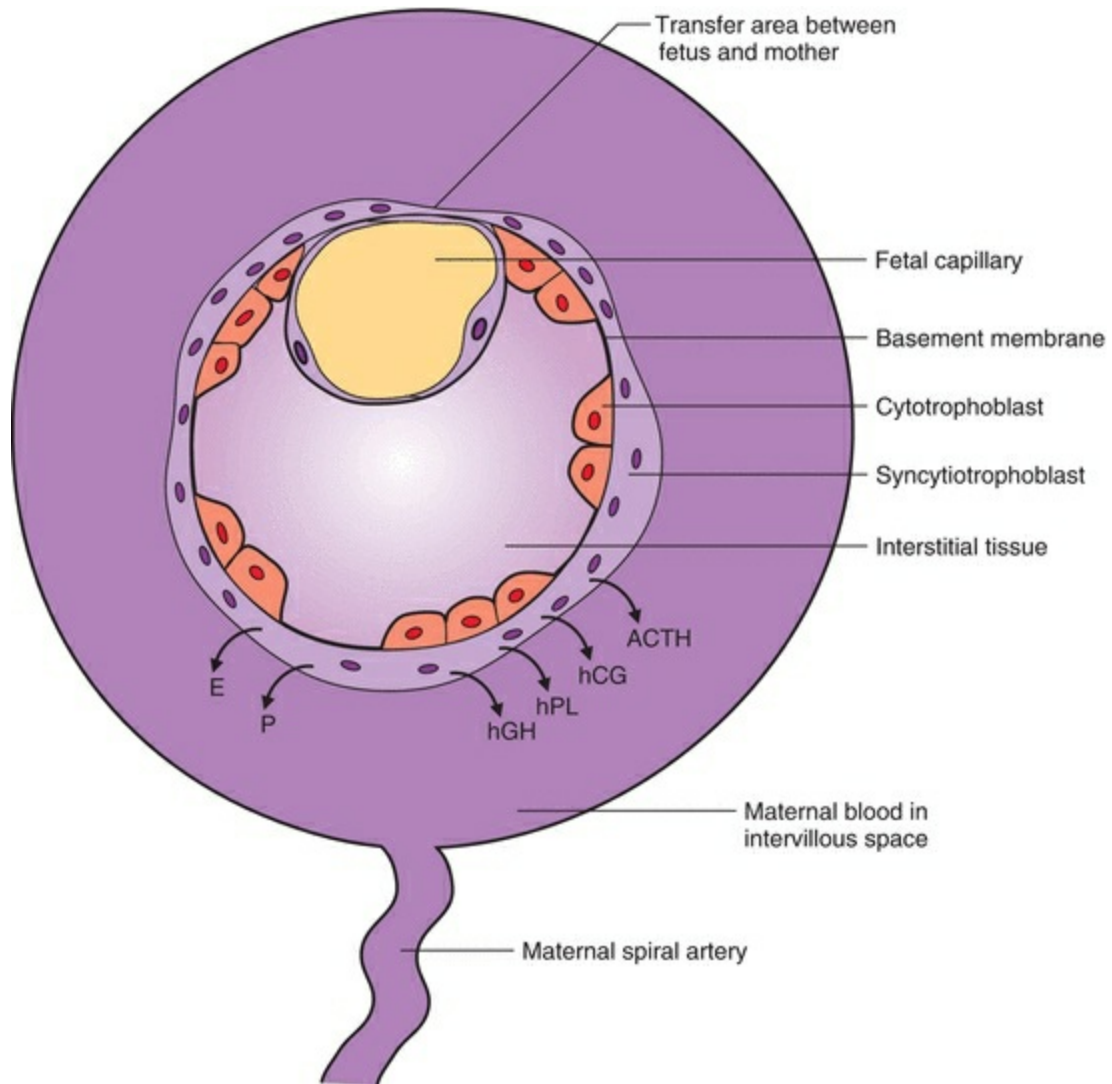
## Key Points: The Differential Diagnosis of an Extremely Low Estriol

- **Impending or present fetal demise**
- **Adrenal hypofunction**
- **Placental sulfatase deficiency**
- **Placental aromatase deficiency**
- **Drug-related effects**

# PROTEIN HORMONES OF PREGNANCY

---

The placental villus is composed of trophoblast, mesenchymal cells, and fetal blood vessels. The two main trophoblastic layers consist of the cytotrophoblast, separate mononuclear cells prominent early in pregnancy and sparse late in pregnancy, and the syncytiotrophoblast, a continuous multinuclear layer on the surface of the villi. The cytotrophoblast is the basic placental stem cell from which the syncytiotrophoblasts arise by differentiation. The syncytiotrophoblast is, therefore, the functional cell of the placenta, the major site of hormone and protein production. Control of this important cellular differentiation is still not understood; however, the process is influenced by hCG and, undoubtedly, a variety of growth factors.<sup>91</sup> The protein hormone system is complicated because individual peptides can have multiple functions (**Figure 7.7**).<sup>92</sup> The surface of the syncytiotrophoblast is in direct contact with the maternal blood in the intervillous space. This may be a reason why placental proteins are secreted preferentially into the mother (**Table 7.1**).



**FIGURE 7.7**

**TABLE 7.1 Proteins Associated with Pregnancy**

<b>Fetal Compartment</b>	<b>Placental Compartment</b>	<b>Maternal Compartment</b>
$\alpha$ -fetoprotein	Hypothalamic-like hormones	Decidual proteins
	GnRH	Prolactin
	CRH	Relaxin
	TRH	Progesterone-associated endometrial protein
	Somatostatin	IGFBP-1
	GHRH	Interleukin-1
	Neuropeptide Y	Colony-stimulating factor-1
	Pituitary-like hormones	Corpus luteum proteins
	hCG	Relaxin
	hPL	Prorenin
	hGH	
	hCT	
	ACTH	
	Oxytocin	
	Prolactin	
	Growth factors	
	IGF-I	
	IGF-II	
	Epidermal growth factor	
	Platelet-derived growth factor	
	Fibroblast growth factor	
	Transforming growth factor- $\alpha$	
	Transforming growth factor- $\beta$	
	Inhibin	
	Activin	
	Follistatin	
	Cytokines	
	Interleukins	
	Interferons	
	Tissue necrosis factor- $\alpha$	
	Colony-stimulating factor-1	
	Other proteins	
	Opiates	
	Prorenin	
	Pregnancy-specific $\beta$ 1-glycoprotein	
	Pregnancy-associated plasma protein A	



# Hypothalamic-Like Releasing Hormones

The human placenta contains many releasing and inhibiting hormones, including GnRH, CRH, TRH, and somatostatin.<sup>93</sup> Because of the presence of hypothalamic-like releasing hormones in an organ that produces tropic hormones, we are motivated to construct a system of regulation analogous to the hypothalamic-pituitary axis. However, as we shall see, this proves to be very difficult.

## Placental Gonadotropin-Releasing Hormone

Gonadotropin-releasing hormone produced by the placenta is biologically and immunologically similar to the hypothalamic GnRH decapeptide. Immunoreactive GnRH can be localized in the cytotrophoblast and syncytiotrophoblast. Evidence indicates that placental GnRH regulates placental steroidogenesis and release of prostaglandins, as well as hCG.<sup>93,94,95,96,97</sup> In some studies, the highest amount of GnRH was present early in pregnancy when the number of cytotrophoblasts is greatest and hCG secretion reaches its peak; however, others report relatively constant levels throughout pregnancy.<sup>98,99</sup> In fact, GnRH provides little augmentation of hCG secretion in first-trimester placental culture, likely because hCG production is already close to maximum. At the second trimester, however, GnRH augments hCG release in a dose-dependent fashion, with this effect diminishing in the term placenta.<sup>100,101</sup> All isoforms of GnRH are expressed in the human placenta, but GnRH-I is the predominant form.<sup>102,103</sup>

The placental receptors for GnRH have a lower affinity than that of GnRH receptors in the pituitary, ovary, and testis.<sup>104,105</sup> This reflects the situation in which the binding site is in close proximity to the site of secretion for the regulatory hormone. A higher affinity is not necessary because of the large amount of GnRH available in the placenta, and the low-affinity receptors avoid response to the low levels of circulating GnRH. GnRH receptors, present in both cytotrophoblasts and syncytiotrophoblasts, are produced in a pattern that parallels the curve of hCG secretion, a further evidence that placental GnRH and its receptor regulate hCG secretion.<sup>106</sup> GnRH release is increased by estrogen, activin-A, insulin, and prostaglandins and inhibited by progesterone, endogenous opiates, inhibin, and follistatin.<sup>92</sup> The GnRH receptor is highly expressed in the fetal zone of the adrenal gland, raising the possibility of another pathway by which the placenta can influence fetal adrenal function.<sup>103</sup>

## Placental Corticotrophin-Releasing Hormone

CRH, identical in structure to hypothalamic CRH, is produced in the trophoblast, the

fetal membranes, and the decidua.<sup>92</sup> Its production is regulated by steroids, decreased by progesterone, and, in contrast to the usual negative feedback action in the hypothalamus, increased by glucocorticoids.<sup>107</sup> These interactions are consistent with the increase in fetal cortisol associated with the last weeks of pregnancy and the increase in ACTH with labor. Placental CRH is further regulated (as in the hypothalamus) by an array of substances such as vasopressin, norepinephrine, angiotensin II, prostaglandins, neuropeptide Y, and oxytocin. CRH release is stimulated by activin and interleukin and inhibited by inhibin and nitric oxide. The progressive increase in maternal CRH levels during pregnancy is due to the secretion of intrauterine CRH into the maternal circulation. The highest levels are found at labor and delivery. A binding protein for CRH exists in the human circulation, and it is produced in placenta, membranes, and decidua.<sup>108</sup> Maternal levels of this binding protein are not different in pregnancy until a slight increase at 35 weeks, followed by a major decrease until term, increasing the bioavailability of CRH in late gestation. Maternal CRH levels are elevated in women with pregnancies under stress, for example, with pre-eclampsia and preterm labor.<sup>92</sup> An increase in placental CRH may be a response to the activation of fetal pituitary ACTH and adrenal cortisol secretion in the presence of hypoxemia. Placental CRH has multiple roles, including stimulation of the fetal adrenal plus parturition and regulation of blood flow. It is not certain to what extent CRH contributes to the increase in maternal adrenal secretion during pregnancy.

Trophoblast, amnion, chorion, and decidua also produce a peptide similar to CRH, named urocortin, that binds to CRH receptors and CRH-binding protein.<sup>109</sup> Urocortin displays activities similar to CRH, such as inducing the secretion of prostaglandins and matrix metalloproteinases in placental cells and fetal membrane cells and directly stimulating steroidogenesis in cells derived from the fetal zone of the adrenal gland.<sup>57,110,111</sup>

## **Placental Thyrotropin-Releasing Hormone**

Thyrotropin-releasing hormone is different from the tripeptide produced by the hypothalamus. It is produced by the placenta from early pregnancy until term. It is localized mainly in the syncytiotrophoblast but also in the fetal and maternal blood vessels as well as in the extravillous trophoblast. Placental TRH is secreted into both the maternal and fetal sides, but the concentration is higher in the fetal circulation, likely due to rapid degradation by proteases on the maternal side.<sup>112</sup> Since placental TRH is predominantly released into the fetal circulation, this placental neuropeptide may be involved in the regulation of thyroid function during fetal life. However, there is no conclusive evidence for this, and the possible paracrine effects of placental TRH remain unclear.<sup>113</sup>

## **Placental Growth Hormone–Releasing Hormone**

The structure of placental growth hormone–releasing hormone (GHRH) is identical to the hypothalamic peptide. It is secreted by the placenta but does not contribute to maternal circulating levels. The presence of GHRH receptor in the placenta suggests a possible paracrine action, but GHRH does not regulate placental GH production.<sup>114</sup> Thus, its function remains unknown.

# Human Chorionic Gonadotropin

Human chorionic gonadotropin is a glycoprotein, a peptide framework to which carbohydrate side chains are attached.<sup>115</sup> Alterations in the carbohydrate component (about one-third of the molecular weight) change the biologic properties. For example, the long half-life of hCG is approximately 24 hours as compared with 2 hours for LH, a 12-fold difference, which is due mainly to the greater sialic acid content of hCG. As with the other glycoproteins, follicle-stimulating hormone (FSH), LH, and thyroid-stimulating hormone (TSH), hCG consists of two subunits, noncovalently linked by disulfide bonds, called alpha ( $\alpha$ ) and beta ( $\beta$ ).<sup>116</sup> The  $\alpha$  subunit in these glycoprotein hormones is identical, consisting of 92 amino acids. Unique biologic activity as well as specificity in immunoassays is attributed to the molecular and carbohydrate differences in the  $\beta$  subunits (see “Heterogeneity” in [Chapter 1](#)).

$\beta$ -hCG is the largest  $\beta$  subunit, containing 145 amino acid residues, including a unique carboxyl terminal tailpiece of 24 amino acid groups. It is this unique part of the hCG structure that allows the production of highly specific antibodies and the utilization of highly specific immunologic assays. The extended sequence in the carboxyl-terminal region of  $\beta$ -hCG contains four sites for glycosylation, the reason why hCG is glycosylated to a greater extent than LH, a difference that is responsible for the longer circulating half-life of hCG. The long half-life in the presence of pregnancy assures the stability of the corpus luteum, while the short half-life of LH allows for the loss of progesterone production in the absence of pregnancy and resumption of menstrual cyclicity. This extended biologic availability of hCG is commonly utilized in ART in lieu of LH for triggering final oocyte maturation.

All human tissues appear to make hCG, but the placenta is different in having the ability to glycosylate the protein, thus reducing its rate of metabolism and giving it biologic activity through a long half-life. The carbohydrate components of the glycoproteins are composed of fructose, galactose, mannose, galactosamine, glucosamine, and sialic acid. Although the other sugars are necessary for hormonal function, sialic acid is the critical determinant of biologic half-life. Removal of sialic acid residues in hCG, FSH, and LH leads to very rapid elimination from the circulation.

Genes for tropic hormones contain promoter and enhancer or inhibitor regions located in the 5' flanking regions upstream from the transcription site. These sites respond to second messengers (cyclic AMP) as well as steroids and other yet unknown regulators. Differences in hCG structure are associated with a different promoter and transcriptional site that is located upstream in the hCG  $\beta$  subunit gene compared with the transcriptional site in the LH  $\beta$  subunit gene. The hCG  $\beta$  subunit promoter does not contain steroid hormone response elements, allowing hCG secretion to escape feedback regulation by the sex steroids, in contrast to FSH and LH.

The protein cores of the two glycoprotein subunits are the products of distinct genes.<sup>117</sup> There is a single human gene for the expression of the  $\alpha$  subunit. The gene for the  $\alpha$  subunit shared by FSH, LH, hCG, and TSH is located on chromosome 6p21.1–23. A single promoter site subject to multiple signals and hormones regulates transcription of the  $\alpha$  gene in both placenta and pituitary. The  $\alpha$  subunit gene is expressed in several different cell types, but the  $\beta$  subunit genes are restricted in cell type. The TSH  $\beta$  gene is expressed only in thyrotrophs regulated by the thyroid hormone; the FSH  $\beta$  gene is expressed in gonadotrophs regulated by GnRH, activin, inhibin, and gonadal steroids; the LH  $\beta$  gene, also expressed in gonadotrophs, is regulated by GnRH and is unaffected by activin and inhibin.<sup>118</sup>

The  $\alpha$  subunit gene requires the activation of distinct regulatory elements in thyrotroph and gonadotroph cells, as well as in the placenta. It is the activation of these cell-specific elements that produces tissue specificity for  $\alpha$ -gene expression. In gonadotrophs, the GnRH-signaling pathway for  $\alpha$ -gene transcription utilizes phosphorylase stimulation of diacylglycerol (DAG) and inositol triphosphate (IP<sub>3</sub>) that lead to a release of intracellular calcium stores. GnRH also stimulates the influx of calcium at the cell membrane. DAG, IP<sub>3</sub>, and calcium work together to stimulate protein kinase C activity. Protein kinase regulation of the  $\alpha$  promoter is a principal part of the overall mechanism. This pituitary process is influenced by multiple factors including growth factors and gonadal steroids. In the placenta, the mechanism also utilizes specific regulatory elements, but the primary signal is mediated by the cyclic AMP-protein kinase A pathway.

The genes that encode for the  $\beta$  subunits of LH, hCG, and TSH are located in a cluster on chromosome 19q13.3. There are six genes for the  $\beta$  subunit of hCG and only one for  $\beta$ -LH.<sup>119</sup> Transcription for the six hCG genes, each with different promoter activity, varies, and it is not certain why hCG requires multigenic expression (perhaps this is necessary to reach the extremely high level of production in early pregnancy). It is thought that  $\beta$ -hCG evolved relatively recently from  $\beta$ -LH, and the unique amino acid terminal extension of  $\beta$ -hCG arose by a read-through mutation of the translation stop codon in the  $\beta$ -LH gene; the DNA sequences of the  $\beta$ -hCG genes and the  $\beta$ -LH gene are 96% identical.<sup>119</sup> Gene studies have indicated that the  $\beta$ -hCG gene originated in the common ancestor of monkeys, apes, and humans after the anthropoids diverged from tarsiers, about 35–55 million years ago.<sup>120,121</sup>

Only primates and equine species have been demonstrated to have genes for the  $\beta$  subunit of chorionic gonadotropin. In contrast to hCG, equine chorionic gonadotropin exerts both LH and FSH activities in many mammalian species because it contains peptide sequences in its  $\beta$  subunit that are homologous to those in the pituitary gonadotropins of other species. The equine  $\beta$ -chorionic gonadotropin gene is identical

to the equine  $\beta$ -LH gene, and although the primate  $\beta$ -hCG gene evolved from the same ancestral  $\beta$ -LH gene, the equine chorionic gonadotropin gene evolved in a different way. The  $\beta$ -LH gene is not expressed in the placenta.

The genetic complexity for the transcription of  $\beta$ -hCG raises the possibility for mutations of these genes as causes of reproductive problems. A search for  $\beta$ -hCG gene deletions in women with recurrent miscarriage or unexplained infertility and for duplications in women with gestational trophoblastic neoplasia found only normal gene structures.<sup>122</sup>

hCG production and secretion are the result of complex interactions among the sex steroids, cytokines, GnRH, and growth factors. GnRH is synthesized by placental cells; GnRH receptors are present on placental cells; and GnRH stimulates the secretion of hCG and the steroid hormones in in vitro studies of placental cells.<sup>123,124,125</sup> Similar responses can be demonstrated with other peptides, such as interleukin- $1\beta$ .<sup>126</sup> Similar to opiate action in the hypothalamus, the endorphins are a major inhibiting influence on hCG secretion.<sup>127</sup> Also similar to the pituitary secretion of gonadotropins, inhibin restrains and activin enhances the GnRH-hCG system, with a positive influence of estrogen and a negative impact by progesterone.<sup>128,129</sup> Follistatin, by binding activin, prevents the stimulatory activity of activin. Other growth factors, specifically IGF-I, IGF-II, TGF- $\alpha$ , and EGF, also influence hCG secretion.

Although a relatively clear story can be constructed into a working concept regarding the autocrine/paracrine interactions in the regulation of the menstrual cycle (Chapter 6), placental function is more complex, and a simple presentation of the many interactions cannot be produced. For example, EGF stimulates hCG secretion but also stimulates inhibin secretion in placental cells, and inhibin suppresses GnRH stimulation of hCG.<sup>130</sup> Inhibin secretion in the placenta is further stimulated by prostaglandins.<sup>131</sup>

Can the cytotrophoblast-syncytiotrophoblast relationship be compared with the hypothalamic-pituitary axis? It does appear that hypothalamic-like peptides (CRH, GnRH) originate in the cytotrophoblast and influence the syncytiotrophoblast to secrete pituitary-like hormones (hCG, hPL, ACTH). Unraveling the interaction is made more difficult by the incredible complexity of the syncytiotrophoblast, a tissue that produces and responds to steroid and peptide hormones, growth factors, and neuropeptides. The best we can say is that locally produced hormones, growth factors, and peptides work together to regulate placental function.

To this day, the only definitely known function for hCG is support of the corpus luteum, taking over for LH on about the eighth day after ovulation, 1 day after implantation, when  $\beta$ -hCG first can be detected in maternal blood. hCG has been detected at the 8-cell stage in the embryo using molecular biology techniques.<sup>132</sup>

Continued survival of the corpus luteum is totally dependent on hCG, and, in turn, survival of the pregnancy is dependent on steroids from the corpus luteum until the seventh week of pregnancy.<sup>1</sup> From the seventh week to the tenth week, the corpus luteum is gradually replaced by the placenta, and by the tenth week, removal of the corpus luteum will not be followed by steroid withdrawal abortion.

It is very probable, but not conclusively proven, that hCG stimulates steroidogenesis in the early fetal testes, so that androgen production will ensue and masculine differentiation can be accomplished.<sup>133</sup> However, normal masculine differentiation occurs in mouse models lacking LH receptors, and molecular evidence indicates that fetal Leydig cells (but not adult cells) respond to ACTH as well as hCG.<sup>134</sup> It is also possible that the function of the inner fetal zone of the adrenal cortex depends on hCG for steroidogenesis early in pregnancy. The  $\beta$ -hCG gene is expressed in fetal kidney and fetal adrenal, suggesting that hCG may affect the development and function of these organs.<sup>135</sup> In addition, hCG may regulate placental development by influencing the differentiation of cytotrophoblasts.<sup>136</sup>

hCG gene expression is present in both cytotrophoblast and syncytiotrophoblast, but it is synthesized mainly in the syncytiotrophoblast.<sup>137</sup> The maternal circulating hCG concentration is approximately 100 IU/L at the time of the expected but missed menses. A maximal level of about 100,000 IU/L in the maternal circulation is reached at 8–10 weeks of gestation. Why does the corpus luteum involute at the time that hCG is reaching its highest levels? One possibility is that a specific inhibitory agent becomes active at this time and another is down-regulation of receptors by the high levels of hCG. In early pregnancy, down-regulation may be avoided because hCG is secreted in an episodic fashion.<sup>138</sup> For unknown reasons, the fetal testes escape desensitization; no receptor down-regulation takes place.<sup>133</sup>

hCG levels decrease to about 10,000–20,000 IU/L by 18–20 weeks and remain at that level to term. It is not certain why hCG levels are decreased in the second half of pregnancy. Advancing gestation is associated with increasing amounts of “nicked” hCG molecules in the maternal circulation.<sup>139</sup> These molecules are missing a peptide linkage on the  $\beta$  subunit, and, therefore, they dissociate into free  $\alpha$  and  $\beta$  subunits. At any one point in time, the maternal circulation contains hCG, nicked hCG, free subunits, and fragments of hCG. In addition, the carbohydrate content of hCG varies throughout pregnancy, with more glycosylation present in early pregnancy (hyperglycosylated hCG). Overall, there are about 20–30 isoforms in the maternal blood, and the production of normal molecules is maximal in early gestation when the biologic actions of hCG are so important.<sup>140</sup> A major route of clearance for hCG is renal metabolism in which a final reduced fragment of the  $\beta$  subunit is produced, known as the  $\beta$ -core fragment.

In the complex process of hCG regulation, several inhibiting factors have been identified, including inhibin and progesterone. The decline in hCG occurs at the time of increasing placental progesterone production, and a direct inhibition by this steroid could explain the lower levels of hCG after the tenth week of gestation.<sup>141</sup>

hCG levels close to term are higher in women bearing female fetuses. This is true of serum levels, placental content, urinary levels, and amniotic fluid concentrations. The mechanism and purpose of this difference are not known. Women who have markedly elevated levels of hCG in the second trimester, with no apparent explanation, have increased risks of spontaneous miscarriage, small-for-gestational-age infants, pre-eclampsia, and preterm delivery.<sup>142</sup>

There are two clinical conditions in which blood hCG titers are especially helpful: trophoblastic disease and ectopic pregnancies. Early pregnancy is characterized by the sequential appearance of hCG, followed by  $\beta$ -hCG and then  $\alpha$ -hCG. The ratio of  $\beta$ -hCG to whole hCG remains constant after early pregnancy. Trophoblastic disease is distinguished by very high  $\beta$ -hCG levels (3–100 times higher than normal pregnancy). Ectopic production of  $\alpha$ - and  $\beta$ -hCG by nontrophoblastic tumors is rare but does occur.

In the United States, hydatidiform moles occur in approximately 1 in 600 induced abortions and 1 in 1,000–2,000 pregnancies. About 20% of patients with hydatidiform moles will develop malignant complications. Following molar pregnancies, the hCG titer should fall to a nondetectable level by 16 weeks in patients without persistent disease. Patients with trophoblastic disease show an abnormal curve (a titer  $>500$  IU/L) frequently by 3 weeks and usually by 6 weeks.<sup>143,144</sup> A diagnosis of gestational trophoblastic disease is made when the  $\beta$ -hCG plateaus or rises over a 2-week period or a continued elevation is present 16 weeks after evacuation. In the United States, the rare occurrence of this disease mandates consultation with a certified subspecialist in gynecologic oncology. Following treatment, hCG should be measured monthly for at least a year, then twice yearly for 5 years. To avoid missing the diagnosis of nonmolar trophoblastic disease, abnormal bleeding after any pregnancy should be evaluated with an hCG measurement, and all patients with elevated hCG levels and early pregnancy losses should be followed with serial hCG testing.

Choriocarcinoma is associated with the increased secretion of  $\beta$ -hCG that is glycosylated to a greater degree, so-called hyperglycosylated hCG, sometimes called invasive trophoblast antigen.<sup>145,146</sup> Hyperglycosylated hCG detected in mothers in the first weeks of normal pregnancies is the major circulating form of hCG, but the levels decrease rapidly to be replaced by the usual hCG isoform by the second trimester.<sup>147</sup> These findings suggest that hyperglycosylated hCG plays a role in regulating trophoblastic invasion; it is suggested that hyperglycosylated hCG is mainly autocrine in its activity, whereas regular hCG functions as a classic hormone in maintaining the



corpus luteum. Measurement of hyperglycosylated hCG in the first weeks of pregnancy may have a role in screening for Down syndrome, but clinical uses for assays that are specific for the many isoforms of hCG have yet to emerge.<sup>148,149</sup> Some of the inaccuracy associated with routine pregnancy testing, especially home pregnancy tests, can be attributed to the variability in detecting hyperglycosylated hCG.

We are just beginning to appreciate the complex heterogeneity of hCG, expressed by the many isoforms that are present in biologic fluids.<sup>149</sup> It is likely that a specific form of hCG can eventually be linked to a specific condition, offering the possibility of clinical application. For example, an assay specific for hyperglycosylated hCG may be of clinical value in assessing implantation and the early weeks of pregnancy; a low level predicts a failing pregnancy.<sup>150</sup> General clinical use awaits improvements in available assays, requiring the development of pure standards and specific antibodies. Meanwhile, clinicians should keep in mind that current assays measure a pool of hCG and its various molecules.

Virtually all ectopic pregnancies are associated with detectable hCG. The hCG level increases at different rates in normal and ectopic pregnancies, and the quantitative measurement of hCG combined with pelvic ultrasonography has had an enormous impact on the diagnosis and management of ectopic pregnancy. This important clinical problem is discussed fully in [Chapter 33](#).

## Key Points: Summary of Contributions of hCG Measurement

- The quantitative measurement of hCG can assess pregnancy viability. A normal rate of rise (at least a 50% increase every 2 days) usually indicates a normal pregnancy.
- When the hCG titer exceeds 1,500–3,000 IU/L, vaginal ultrasonography should identify the presence of an intrauterine gestation.
- Declining hCG levels are consistent with effective treatment, and persistent or rising levels indicate the presence of viable trophoblastic tissue.

With the use of modern sensitive assays, it is now appreciated that virtually all normal human tissues produce the intact hCG molecule. hCG can be detected in the blood of normal men and women, where it is secreted in a pulsatile fashion in parallel with LH; the source of this circulating hCG is the pituitary gland, perhaps a consequence of evolution when hCG was derived from LH.<sup>151,152,153,154</sup> The concentration of this

pituitary hCG normally approximates the sensitivity of the usual modern assay, and for this reason, many laboratories will not report the presence of hCG unless the level is 5–10 IU/L or higher. hCG produced in sites other than the placenta has little or no carbohydrate; therefore, it has a very short half-life and is rapidly cleared from the circulation. Significant levels of free  $\alpha$  subunit are also present in the circulation of healthy individuals; however, the levels of the  $\beta$  subunit are extremely low.

# False-Positive Tests or “Phantom” hCG

False-positive results with the hCG assay occasionally occur and have been long-recognized, resulting in inappropriate surgical or medical treatment. The level is relatively low, usually less than 150 IU/L. There are many causes, including the hCG secreted by the pituitary, but this clinical problem is usually due to interference in the assay by other substances, especially antibodies to LH or antianimal immunoglobulins.<sup>155</sup> The capture or tracer antibodies used in the hCG assays may be from various animals, and some humans have antibodies that can cross-react with these animal antigens in a nonspecific fashion. These are referred to as heterophilic antibodies. Humans with recent exposure to mononucleosis and those with IgA deficiency syndrome are prone to develop heterophile antibodies leading to false-positive results.<sup>156</sup> In addition, nontrophoblastic tumors can secrete detectable hCG.

A false-positive result usually remains at the same level over time, neither increasing nor decreasing. When the clinical presentation is uncertain or not consistent with laboratory results (especially an absence of trophoblastic tissue), a positive hCG can be confirmed by several procedures.

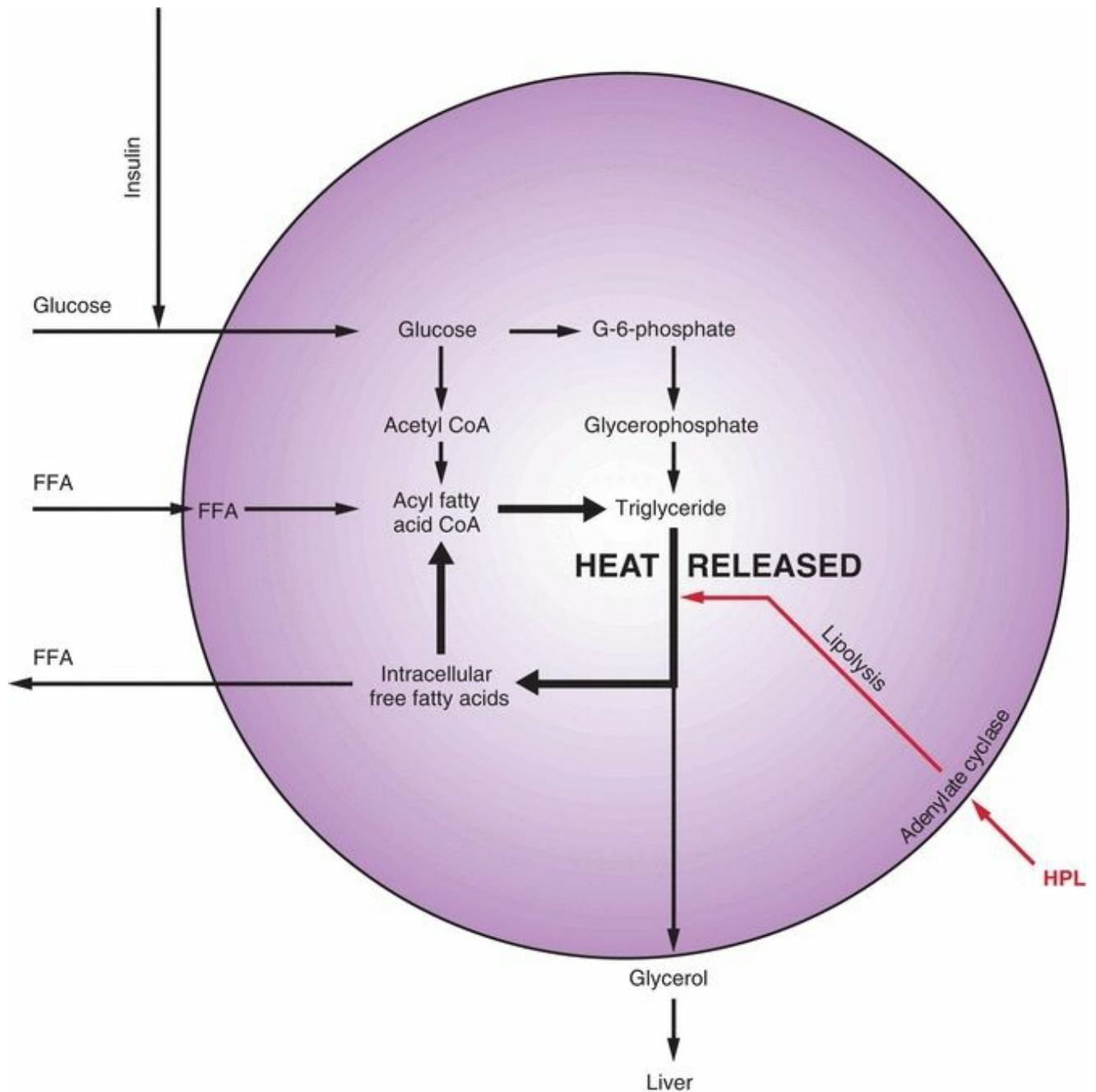
## Key Points: Positive hCG Confirmation

- Obtaining a similar result with a different assay method. If the results from a lab using an alternative commercial assay are negative or vary greatly, then a false-positive hCG can be assumed.
- Demonstrating the presence of hCG in the urine. Since large molecules like heterophilic antibodies do not cross the glomerular basement membrane, there will be no detectable hCG in the urine in the case of a false-positive hCG.
- Demonstrating parallel results with serial dilutions of the hCG standard and the patient’s serum sample. In the presence of heterophilic antibodies, the results will not decrease as expected by performing a serial dilution.

# Human Placental Lactogen

Human placental lactogen (hPL) (sometimes called human chorionic somatomammotropin), also secreted by the syncytiotrophoblast, is a single-chain polypeptide of 191 amino acids held together by 2 disulfide bonds. It is very similar in structure to human growth hormone (hGH) but has only 3% of hGH somatotropin activity. The growth hormone-hPL gene family consists of 5 genes on chromosome 17q22–q24. Two genes encode for hGH, one in the pituitary and one in the placenta, and three for hPL; however, only two of the hPL genes are abundantly active in the placenta, each producing the same hPL hormone.<sup>157</sup> The third hPL gene does generate a protein in the placenta, but its activity is limited.<sup>158</sup>

The half-life of hPL is short, about 15 minutes, hence its appeal as an index of placental problems. The level of hPL in the maternal circulation is correlated with fetal and placental weight, steadily increasing until plateauing in the last 4 weeks of pregnancy (5–10 mg/mL). There is no circadian variation, and only minute amounts of hPL enter the fetal circulation. Very high maternal levels are found in association with multiple gestations; levels up to 40 mg/mL have been found with quadruplets and quintuplets. An abnormally low level is anything less than 4 mg/mL in the last trimester (**Figure 7.8**).

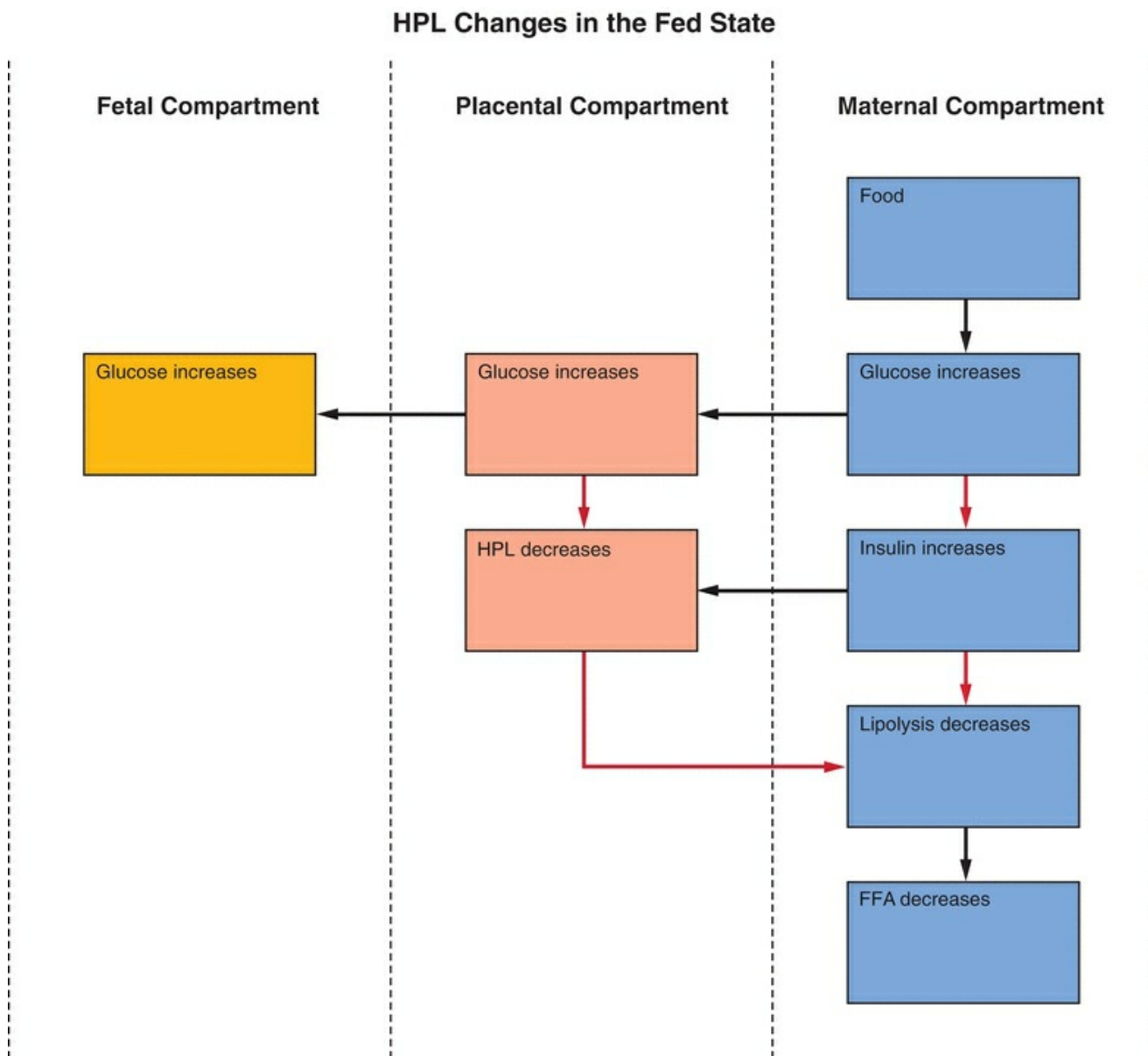


**FIGURE 7.8**

## Physiologic Function

Although hPL is similar in structure to growth hormone, neither growth hormone-releasing hormone nor somatostatin influence placental hPL secretion. One would expect the regulatory mechanism to involve PLGFs and cytokines, as is the case with other placental steroids and peptides. Although hPL has about 50% of the lactogenic activity of sheep prolactin in certain bioassays, its lactogenic contribution in human pregnancy is uncertain.

In the mother, hPL stimulates insulin secretion and IGF-I production and induces insulin resistance and carbohydrate intolerance. However, the well-recognized insulin resistance in pregnancy is not solely an effect of hPL; for example, placental cytokines (especially TNF- $\alpha$ ) influence this metabolic state.<sup>159</sup> Experimentally, the maternal level of hPL can be altered by changing the circulating level (chronically, not acutely) of glucose. hPL is elevated with hypoglycemia and depressed with hyperglycemia. This response in placental hPL may be secondary to the glucose-mediated changes in insulin levels; in vitro experiments with placental tissue indicated a decrease in hPL with a decrease in glucose, followed by an increase in hPL after exposure to insulin (**Figure 7.9**).<sup>160</sup> This information and studies in fasted pregnant women have led to the following formulation for the physiologic function of hPL.<sup>161,162,163,164,165,166,167</sup>



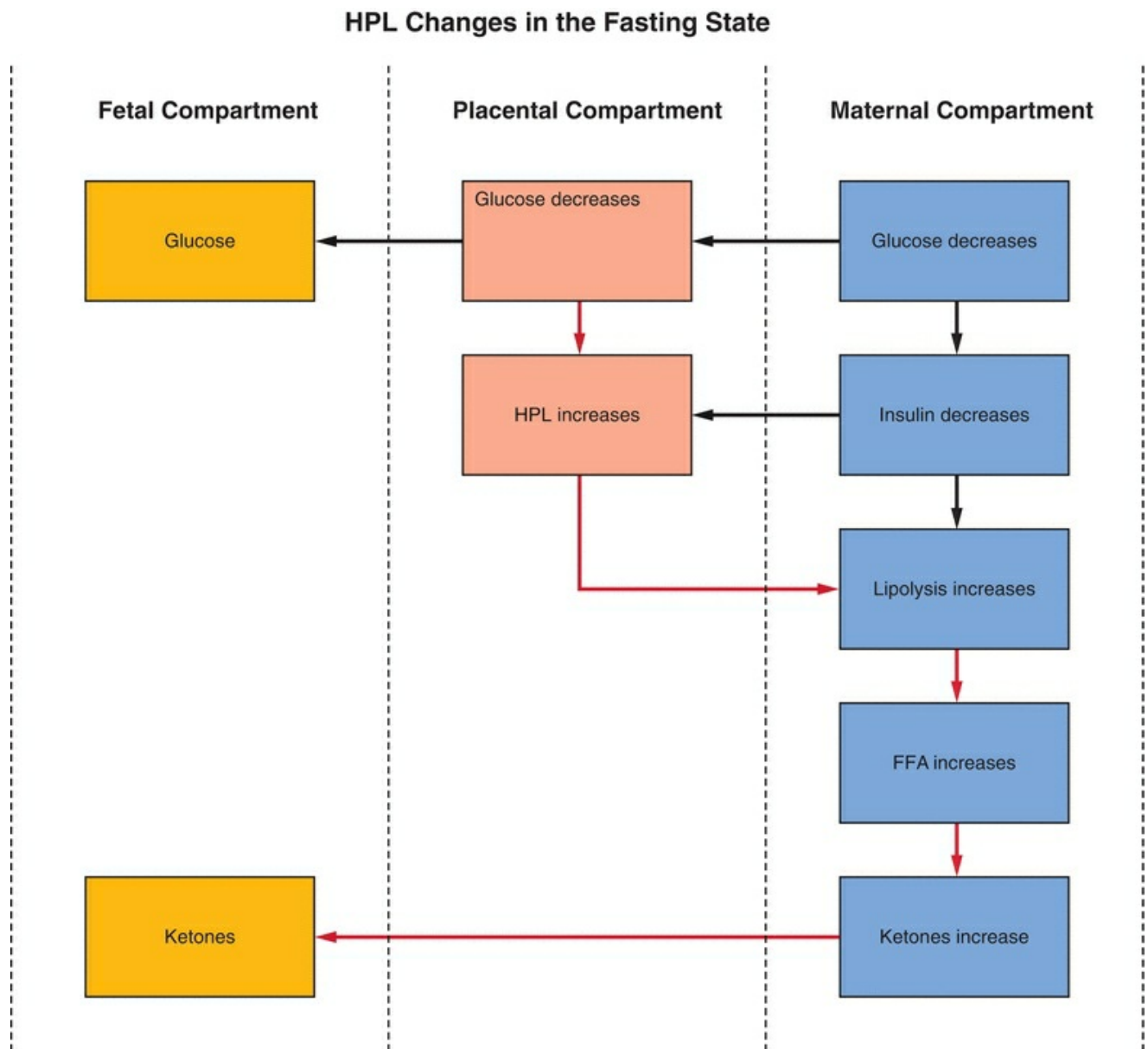
## FIGURE 7.9

The metabolic role of hPL is to mobilize lipids as free fatty acids. In the fed state, there is abundant glucose available, leading to increased insulin levels, lipogenesis, and glucose utilization. This is associated with decreased gluconeogenesis and a decrease in the circulating free fatty acid levels, because the free fatty acids are utilized in the process of lipogenesis to deposit storage packets of triglycerides (see [Chapter 19, Obesity](#)).

Pregnancy has been likened to a state of “accelerated starvation,” characterized by a relative hypoglycemia in the fasting state.<sup>164</sup> This state is due to two major influences:

- 1. Glucose provides the major, although not the entire, fuel requirement for the fetus. A difference in gradient causes a constant transfer of glucose from the mother to the fetus.**
- 2. Placental hormones, specifically estrogen and progesterone, and especially hPL, interfere with the action of maternal insulin. In the second half of pregnancy when hPL levels rise approximately 10-fold, hPL is a major force in the diabetogenic effects of pregnancy. The latter is characterized by increased levels of insulin associated with decreased cellular response (hyperinsulinemia and peripheral insulin resistance).**

As glucose decreases in the fasting state, hPL levels rise. This stimulates lipolysis leading to an increase in circulating free fatty acids. Thus, a different fuel is provided for the mother so that glucose and amino acids can be conserved for the fetus. With sustained fasting, maternal fat is utilized for fuel to such an extent that maternal ketone levels rise. There is limited transport of free fatty acids across the placenta. Therefore, when glucose becomes scarce for the fetus, fetal tissues utilize the ketones that do cross the placenta. Thus, decreased glucose levels lead to decreased insulin and increased hPL, increasing lipolysis and ketone levels. hPL also may enhance the fetal uptake of ketones and amino acids. The mechanism for the insulin antagonism by hPL may be the hPL-stimulated increase in free fatty acid levels, which, in turn, directly interfere with insulin-directed entry of glucose into cells. These interactions significantly involve growth factors, particularly insulin-like growth factor, at the cellular level ([Figure 7.10](#)).



**FIGURE 7.10**

This mechanism can be viewed as an important means to provide fuel for the fetus between maternal meals. However, with a sustained state of inadequate glucose intake, the subsequent ketosis may impair fetal brain development and function. Pregnancy is not the time to severely restrict caloric intake. Indeed, impaired fetal growth and development are now recognized to correlate with adverse cardiovascular risk factors and disease in adult life as well as diabetes mellitus.<sup>50,168,169</sup>

The lipid, lipoprotein, and apolipoprotein changes during pregnancy are positively correlated with changes in estradiol, progesterone, and hPL.<sup>170</sup> The lipolytic activity of hPL is an important factor because hPL is also linked to the maternal blood levels of cholesterol, triglycerides, phospholipids, and insulin-like growth factor-I.



When glucose is abundant, as in pregnant women with diabetes mellitus, the flow of nutritional substrates (in this case, glucose and amino acids) is in the direction of the fetus. The subsequent hyperinsulinemia in the fetus becomes a strong stimulus to growth, perhaps compounded by maternal hyperinsulinemia caused by obesity as well as the hyperinsulinemia due to the peripheral resistance produced by the hormones of pregnancy.<sup>171</sup> Fetal undernutrition lowers fetal IGF-I levels, and this is associated with a high prevalence of insulin resistance later as adults.<sup>172</sup> In vitro studies indicate that hPL, despite its lower levels in the fetus, directly affects fetal tissue metabolism, including synergistic actions with insulin, especially on glycogen synthesis in the liver. The failure of fetal growth hormone to affect fetal growth (e.g., normal growth in anencephalics) further indicates that hPL may be the fetal growth hormone.

## **hPL Clinical Uses**

Blood levels of hPL are related to placental function. Some studies indicated that hPL was valuable in screening patients for potential fetal complications, but others did not support the use of hPL measurements. Although use of the hPL assay can have an impact on perinatal care, fetal heart rate-monitoring techniques are more reliably predictive and sensitive for assessing fetal well-being. Furthermore, totally uneventful pregnancies have been reported, despite undetectable hPL.<sup>173,174</sup>

Previous suggestions that a low or declining level of hPL and a high level of hCG are characteristic of trophoblastic disease were not accurate. Because of the rapid clearance of hPL (half-life of about 20 minutes), aborting molar pregnancies is likely to have low levels of hPL, whereas the level of hCG is still high. However, intact molar pregnancies can have elevated levels of both hPL and hCG.<sup>175</sup>

# Human Chorionic Thyrotropin

The human placenta contains two thyrotropic substances. One is called human chorionic thyrotropin (hCT), which is similar in size and action to pituitary TSH. The content in the normal placenta is very small, and it is unlikely that it has any physiologic importance. hCT differs from the other glycoproteins in that it does not appear to share the common  $\alpha$  subunit. Antiserum generated to  $\alpha$ -hCG does not neutralize the biologic activities of hCT, but it does neutralize that of hCG and pituitary TSH.

Rarely, patients with trophoblastic disease have hyperthyroidism and, even more rarely, thyroid storm.<sup>176</sup> hCG has intrinsic thyrotropic activity, indicating that hCG is the second placental thyrotropic substance.<sup>177,178,179</sup> It has been calculated that hCG contains approximately 1/4,000th of the thyrotropic activity of human TSH. In conditions with very elevated hCG levels, such as hydatidiform mole, the thyrotropic activity can be sufficient to produce hyperthyroidism (with elevated free thyroxine, FT4, but suppressed levels of TSH), and this can even be encountered in normal pregnancy.<sup>180</sup> Another very rare cause of hyperthyroidism in pregnancy is an inherited mutation of the thyrotropin receptor that makes it hypersensitive to hCG.<sup>181</sup>

There is a correlation between elevated thyroid function and hyperemesis gravidarum.<sup>182,183</sup> Hyperemesis gravidarum is usually associated with very high hCG levels, and some of these patients develop hyperthyroidism as well.<sup>184</sup> Although free T4 will be elevated and TSH suppressed, patients with gestational hyperthyroidism do not develop the clinical signs of Graves disease and TSH-receptor antibodies, TRAb, will not be detectable. These hyperthyroid manifestations in normal pregnancies may be linked to a specific subpopulation of hCG molecules with greater thyrotropic bioactivity (because highly purified, standard hCG has only trivial TSH-like activity).<sup>185</sup> Specifically, hCG with reduced sialic acid content is increased in pregnant patients with hyperemesis and hyperthyroidism.<sup>186</sup> The thyroid hormone changes in pregnancy and the role of hCG as a thyroid stimulator are also discussed in [Chapter 20](#).

# Human Chorionic Adrenocorticotropin

The rise in maternal free cortisol and aldosterone that takes place throughout pregnancy is due to placental ACTH and CRH production and secretion into the maternal circulation and due to the effects of estrogen and progesterone on the maternal hypothalamic-pituitary axis.<sup>187,188,189</sup> The placental content of ACTH is higher than can be accounted for by the contribution of sequestered blood. In addition, cortisol levels in pregnant women are resistant to dexamethasone suppression, indicating that there is a component of maternal ACTH and CRH that does not originate in the maternal hypothalamus and pituitary gland. The placental production of ACTH in the syncytiotrophoblast (and the increase in maternal ACTH levels) is probably due to stimulation by the locally produced CRH in the cytotrophoblast.<sup>190</sup> Placental pro-opiomelanocortin (POMC) gene expression and ACTH content are present throughout pregnancy and increase in the weeks before term.<sup>191</sup> One can speculate that placental ACTH and CRH raise maternal adrenal activity in order to provide the basic building blocks (cholesterol and pregnenolone) for placental steroidogenesis. The increased activity of the maternal adrenal gland is also necessary for the expansion of maternal blood volume during pregnancy.

The maternal ACTH response to the administration of CRH during pregnancy is blunted, reflecting a high level of endogenous CRH and ACTH activity. Vasopressin stimulates ACTH secretion in the pituitary, both directly and indirectly by potentiating the action of CRH. In contrast to the blunted response to CRH during pregnancy, the ACTH response to vasopressin is increased.<sup>192</sup> This is further evidence that placental CRH produces a state of chronic stimulation for the maternal pituitary-adrenal axis. Thus, in contrast to nonpregnant women, CRH levels in maternal plasma are relatively high, rising in the second trimester to peak values at term.<sup>193,194</sup> In contrast to the hypothalamic-pituitary axis, placental CRH and ACTH are not suppressed by glucocorticoids, and, therefore, maternal ACTH levels are little affected by corticosteroid administration to the mother. Oxytocin is a potent stimulator of CRH and ACTH placental production, a logical mechanism to meet the stress of labor and delivery. Binding of CRH with the CRH-binding protein blunts physiologic response, but the binding protein capacity is reached late in pregnancy, increasing the biologic activity of CRH and further increasing cortisol availability during labor and delivery.<sup>195</sup>

Both maternal and fetal levels of CRH are further elevated in pathologic states such as premature labor, hypertension, fetal asphyxia, and intrauterine growth retardation.<sup>196</sup> Because CRH also stimulates prostaglandin synthesis in the placenta and fetal membranes, it is implicated in the premature labor that accompanies pathologic conditions.<sup>197</sup>

# Growth Hormone, Growth Hormone–Releasing Hormone, and Somatostatin

One of the two growth hormone genes on chromosome 17 is expressed only in the syncytiotrophoblast of the placenta; the other is expressed in the pituitary.<sup>158,198</sup> The placental growth hormone is not identical to pituitary growth hormone, differing in 13 amino acids, and after 15–20 weeks of pregnancy, placental growth hormone gradually replaces pituitary growth hormone in the maternal circulation.<sup>158,199</sup> Indeed, by term, maternal pituitary growth hormone is undetectable. Placental growth hormone is not present in fetal blood. The changes in maternal levels of insulin-like growth factors and insulin-like growth factor–binding proteins reflect regulation by this placental growth hormone.<sup>200</sup> Maternal IGF-I levels in the circulation increase during pregnancy in a pattern similar to that of placental growth hormone. Placental growth hormone is not regulated by placental growth hormone–releasing hormone but responds inversely to maternal glucose and insulin levels, protecting glucose availability for the fetus.<sup>158,201</sup>

Placental growth hormone can also stimulate gluconeogenesis and lipolysis in maternal organs. **It is believed, therefore, that placental growth hormone influences fetal growth by affecting maternal metabolism.** Placental growth hormone and maternal IGF-1 levels are lower in pregnancies with intrauterine growth retardation and higher in women with female fetuses.<sup>200,202</sup> Maternal circulating levels of placental growth hormone are higher at midgestation in pregnancies with fetal Down syndrome.<sup>203</sup>

# **$\alpha$ -Fetoprotein**

$\alpha$ -fetoprotein (AFP) is a relatively unique glycoprotein (590 amino acids and 4% carbohydrate) derived largely from fetal liver and partially from the yolk sac until it degenerates at about 12 weeks. In early pregnancy (5–12 weeks), amniotic fluid AFP is mainly from yolk sac origin, whereas maternal circulating AFP is mainly from the fetal liver.<sup>204</sup> Its function is unknown, but it is comparable in size to albumin and contains 39% sequence homology; it may serve as a protein carrier of steroid hormones in fetal blood. AFP may also be a modulator of cell proliferation, synergizing with various growth factors.<sup>205</sup>

Peak levels of AFP in the fetal blood are reached at the end of the first trimester; then levels decrease gradually until a rapid decrease begins at 32 weeks. Maternal blood levels are much lower than fetal levels, rising until week 32 (probably because of the great increase in trophoblast villous surface area during this time period) and then declining. Because AFP is highly concentrated in the fetal central nervous system, abnormal direct contact of CNS with the amniotic fluid (as with neural tube and abdominal wall defects) results in elevated amniotic fluid and maternal blood levels. Other fetal abnormalities, such as intestinal obstruction, omphalocele, and congenital nephrosis, are also associated with high levels of AFP in the amniotic fluid. Besides indicating a variety of fetal anomalies, elevated maternal AFP levels are also present with multiple pregnancies and associated with an increased risk of spontaneous miscarriage, stillbirth, preterm birth, pre-eclampsia, neonatal death, and low birth weight (probably reflecting an increase in villous surface area in response to an adverse intrauterine environment).<sup>206,207,208</sup> Conversely, very low maternal AFP levels are associated with large birth weight infants, miscarriage, and stillbirth.<sup>208,209</sup>

## **Multiple Marker Screening and Cell-Free DNA**

Down syndrome is a very common genetic cause of abnormal development. The majority of cases are due to trisomy 21, an extra chromosome usually due to nondisjunction in maternal meiosis. A low maternal level of AFP is associated with trisomy 21. However, there is extensive overlap between normal and affected pregnancies responsible for a significant false-positive rate. Several placental products are secreted in increased amounts in pregnancies with trisomy 21, including hCG and hPL, whereas the maternal circulating level of unconjugated estriol is lower in affected pregnancies. The free  $\beta$  subunit of hCG usually circulates in low concentrations, but in the presence of a fetus with Down syndrome, the levels are high. With trisomy 18, all markers are decreased. Until recently, screening for fetal aneuploidy combined three markers: AFP,  $\beta$ -hCG, and unconjugated estriol.<sup>210,211,212</sup> This protocol detected 85% of

open neural tube defects and 80% of Down syndrome, if gestational age is determined by ultrasonography.<sup>213</sup> However, Down syndrome represents only about 50% of the chromosomal abnormalities that can be detected.

The multiple marker screening protocol measures AFP, unconjugated estriol, and hCG in maternal serum at 16–18 weeks of gestation, the optimal time for neural tube defect detection. Using the patient’s age and the laboratory results, patients are provided a statistical estimation of risks for both neural tube defects and Down syndrome. Corrections are applied for race and weight. A pattern similar to that of Down syndrome has also been reported to be associated with hydropic fetal Turner syndrome.<sup>214</sup>

The most critical factor for correct risk assessment is accurate gestational dating. A 2-week error in dating can change the calculated risk for Down syndrome 10-fold (Table 7.2).

## **TABLE 7.2 Triple Test Values**

	<b>AFP</b>	<b>Estriol</b>	<b>hCG</b>
Down syndrome	Low	Low	High
Trisomy 13	Normal	No data	Low
Trisomy 18	Low	Low	Low
Open neural tube defects	High	Normal	Normal
IUGR, preterm birth, stillbirth	High	No data	No data
Multiple gestation	High	High	High

Therefore, ultrasound confirmation of gestational dating is essential. In addition, ultrasonography will indicate fetal number (multiple pregnancies are associated with higher marker values) and assess the fetus and placenta for anomalies. Indeed, protocols are in current operation that include ultrasonography for biometric measurements (nuchal translucency, absence of a nose bone) combined with hormone markers as well as substances such as inhibin-A and pregnancy-associated plasma protein A (PAPP-A).<sup>215,216</sup> Protocols are also being developed that use these markers to predict fetal loss.<sup>217</sup> The combination of hormonal measurements with ultrasonography allows earlier antenatal screening, even in the first trimester, and multiple tests reduce the false-positive rate.<sup>218,219</sup> Assessment of uterine artery pulsatility by Doppler ultrasonography further adds to evaluation accuracy. The technology that allows one to measure fetal cfDNA has been rapidly transforming the field of prenatal screening as aneuploidy screening for trisomy 21 (Down syndrome), trisomy 18, trisomy 13, and sex chromosome aneuploidies can be performed using next-generation sequencing. The sources of cfDNA are both maternal and fetal. The primary source of so-called “fetal” cfDNA in the maternal circulation is thought to be apoptosis of placental cells (syncytiotrophoblast), which gets cleared from the maternal circulation soon after delivery.<sup>220</sup> The maternal contribution to most cfDNA is circulating hematopoietic

cells.<sup>221</sup> While the fetal DNA is not isolated, in the setting of a fetal chromosomal trisomy or monosomy, the differences in the fetal contribution are immense and can be detected as small differences in the total complement of DNA representative of each chromosome in the combined sample of circulating maternal and fetal cfDNA. cfDNA is the most sensitive screening option for detecting trisomy 21, 18, and 13,<sup>222</sup> and it is commonly used as a secondary screening test in women found to be screen-positive (high risk) as a result of a previous screening test. It is also increasingly being offered as a primary screening test for fetal aneuploidy in an increasing number of countries including the United States.<sup>223</sup> It is likely that further advances in this noninvasive technology will make it possible to expand screening to include other genetic conditions including monogenic disorders as well as make the test more affordable and accessible to a wider population.

The multiple marker protocol is for screening a low-risk population regardless of age, and similarly, the cfDNA testing is for initial screening or alternatively for further screening of a population deemed to be of higher risk based on prior screening. It is important to remember that amniocentesis or chorionic villus sampling is necessary for final diagnosis. Genetic amniocentesis or chorionic villus sampling has been the standard recommendation for older women; however, although multiple marker screening does not detect all chromosomal abnormalities, it is now strongly argued that the detection rate is so high that multiple marker screening or cfDNA testing with ultrasonography should be offered even to younger women, and a decision for amniocentesis or chorionic villus sampling is then based on the estimated risk for an abnormal fetus.<sup>211,224</sup>



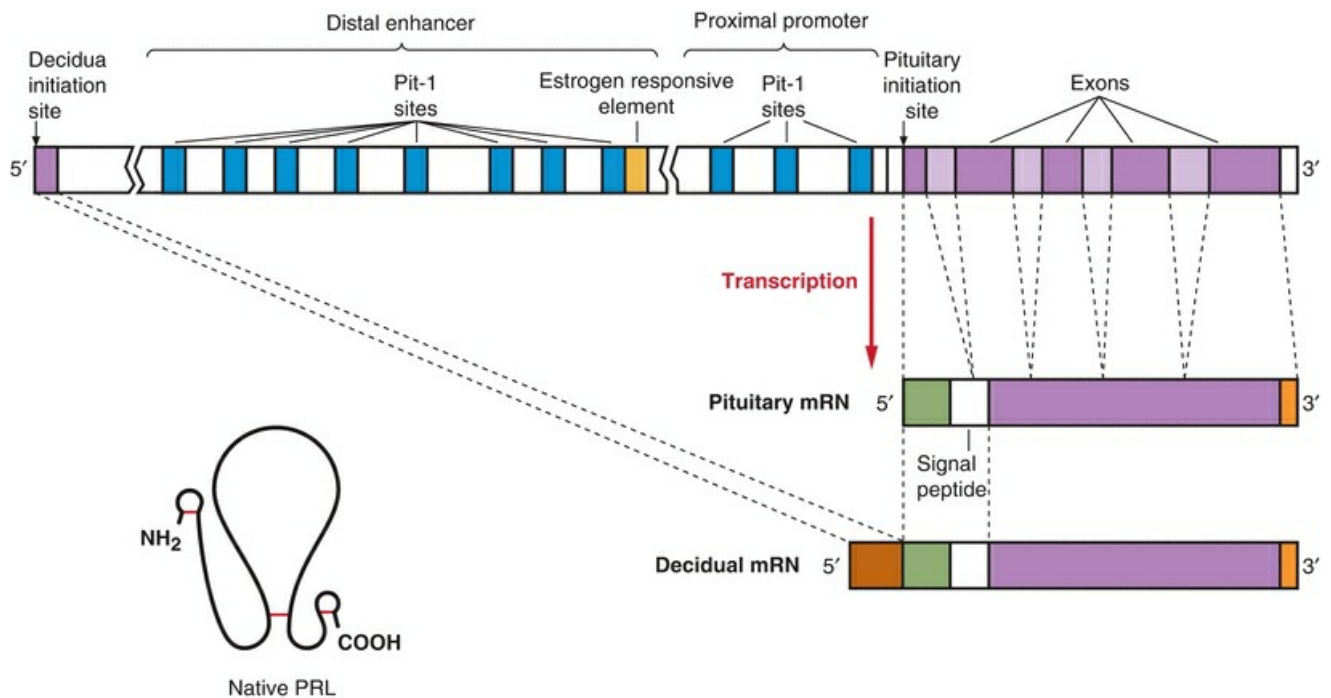
# Relaxin

Relaxin is a peptide hormone produced by the corpus luteum of pregnancy, which is not detected in the circulation of men or nonpregnant women. A collection of related peptides compose the relaxin family, encoded by three relaxin genes and four insulin-like peptide genes. These peptides are similar in structure to insulin, composed of two short peptide chains (24 and 29 amino acids, respectively) linked by disulfide bridges. Although it has been argued that the human corpus luteum is the sole source of relaxin in pregnancy, it has also been identified in human placenta, decidua, and chorion.<sup>225,226,227</sup> The maternal serum concentration rises during the first trimester when the corpus luteum is dominant and declines in the second trimester.<sup>228</sup> This suggests a role in maintaining early pregnancy, but its function is not really known. In animals, relaxin softens the cervix (ripening), inhibits uterine contractions, and relaxes the pubic symphysis; however, relaxin levels do not correlate with changes in peripheral joint laxity in human pregnancy.<sup>229</sup> The animal cervical changes are comparable to those seen with human labor, and in in vitro studies of human cervical stromal cells, relaxin induces changes consistent with clinical ripening.<sup>230,231</sup> Human relaxin binds primarily to relaxin receptors in the decidua and chorionic cytotrophoblast.<sup>232</sup> Expression of the relaxin receptors is greatest before term and reduced after labor.<sup>233,234</sup> Relaxin, originating in the decidua and binding to its receptors in the fetal membranes, increases cytokine levels that can activate matrix metalloproteinases and lead to rupture of the membranes and labor.<sup>235</sup> A search for important roles of relaxin in human pregnancy continues, but these roles appear to be facilitatory, not mandatory.

To examine the contribution of the corpus luteum, normally, pregnant women who conceived naturally were compared with women pregnant with donated oocytes (and therefore without corpora lutea).<sup>236</sup> Circulating relaxin was undetectable in the women without functioning ovaries, confirming that its major source is the corpus luteum. No effect on prolactin secretion was observed, but it did appear that relaxin enhanced growth hormone secretion by the pituitary. Obviously, relaxin is not necessary for the maintenance of pregnancy and labor because the rest of pregnancy and the outcomes did not differ between those women with circulating levels of relaxin and those with undetectable levels. However, recombinant relaxin and drugs targeted to the relaxin receptors are being tested for clinical applications.<sup>237,238</sup> Thus far, potential uses include a decrease in collagen formation, an increase in vasodilation, an increase in vascular endothelial growth factor, and the release of histamine. In monkey studies, relaxin treatment combined with estrogen is effective for cervical ripening.<sup>239</sup>

# Prolactin

Following ovulation, the endometrium becomes a secretory organ and remains so throughout pregnancy. Decidualized endometrium secretes renin, which may be involved in the regulation of water and electrolytes in the amniotic fluid, and relaxin, which may influence prostaglandin production in the membranes. One of the best studied special endocrine functions of the decidual endometrium is the secretion of prolactin. Prolactin is synthesized by the endometrium during a normal menstrual cycle, but this synthesis is not initiated until histologic decidualization begins about day 23.<sup>240,241</sup> The control of prolactin secretion by decidual tissue has not been definitively established. Some argue that once decidualization (**Figure 7.11**) is established, prolactin secretion continues in the absence of either progesterone or estradiol, although there is evidence for an inhibitory feedback by decidual proteins (perhaps prolactin itself).<sup>240,242</sup> Others indicate that endometrial prolactin production requires the combined effects of progestin and estrogen hormones plus the presence of other placental and decidual factors, including relaxin, IGF-I, and specific stimulatory and inhibitory proteins.<sup>243</sup> Indeed, human decidual cells express a prolactin-releasing peptide that stimulates prolactin secretion.<sup>244</sup> It is recognized, however, that transcriptional regulation of the prolactin gene in the decidua is not identical to that in the pituitary and that unique transcription factors are involved.<sup>245</sup> Prolactin, hPL, and growth hormone bind to the same receptor that activates the JAK/Stat signaling pathway resulting in tyrosine phosphorylation and activation of transcription factors.



## FIGURE 7.11

During pregnancy, prolactin secretion is limited to the fetal pituitary, the maternal pituitary, and the uterus. Neither trophoblast nor fetal membranes synthesize prolactin, but both the myometrium and endometrium can produce prolactin. The endometrium requires the presence of progesterone to initiate prolactin, whereas progesterone suppresses prolactin synthesis in the myometrium. Prolactin derived from the decidua is the source of prolactin found in the amniotic fluid.<sup>246</sup> The prolactin in the fetal circulation is derived from the fetal pituitary. Decidual prolactin is transcribed by a gene with an additional exon compared with the pituitary, accounting for a different system of regulation.<sup>247</sup>

During pregnancy, prolactin maternal blood levels rise from the normal level of 10–25 ng/mL to high concentrations, beginning about 8 weeks and reaching a peak of 200–400 ng/mL at term.<sup>248,249</sup> The increase in prolactin parallels the increase in estrogen beginning at 7–8 weeks of gestation, and the mechanism for increasing prolactin secretion is believed to be estrogen suppression of the hypothalamic prolactin-inhibiting factor, dopamine, and direct stimulation of prolactin gene transcription in the pituitary.<sup>250,251</sup> There is marked variability in maternal prolactin levels in pregnancy, with a diurnal variation similar to that found in nonpregnant persons. The increase in maternal levels of prolactin represents maternal pituitary secretion in response to estrogen as the fetus prepares the mother for breastfeeding. The mechanisms for pituitary secretion of prolactin are discussed in [Chapters 2, 5, and 16](#).

Amniotic fluid concentrations of prolactin parallel maternal serum concentrations until the tenth week of pregnancy, rise markedly until the 20th week, and then undergo a decrease until delivery. The maternal and fetal blood levels of prolactin are derived from the respective pituitary glands, and, therefore, dopamine agonist suppression of pituitary secretion of prolactin throughout pregnancy produces low maternal and fetal blood levels, yet there is normal fetal growth and development, and amniotic fluid levels are unchanged.<sup>252</sup> Fortunately, decidual secretion of prolactin is unaffected by dopamine agonist treatment because decidual prolactin is important for fluid and electrolyte regulation of the amniotic fluid. This decidual prolactin is transported across the membranes in a process that requires the intact state of amnion and chorion with adherent decidua. The prolactin receptor is expressed in fetal and maternal tissues in the following descending order of intensity: chorionic cytotrophoblast, decidua, amnion, and syncytiotrophoblast.<sup>253</sup> This molecular expression is consistent with local actions.

No clinical significance can be attached to maternal and fetal blood levels of prolactin in abnormal pregnancies. Decidual and amniotic fluid prolactin levels are

lower, however, in hypertensive pregnancies and in patients with polyhydramnios.<sup>254,255</sup> Prolactin receptors are present in the chorion laeve, and their concentration is lower in patients with polyhydramnios.<sup>256</sup> Prolactin reduces the permeability of the human amnion in the fetal to maternal direction. This receptor-mediated action takes place on the epithelium lining the fetal surface.<sup>257</sup> There is also evidence that prolactin derived from the fetal pituitary contributes to the regulation of fetal water and electrolyte balance by acting as an antidiuretic hormone.<sup>258</sup>

# Cytokines and Growth Factors

The placenta synthesizes many proteins that are part of the normal composition of cells throughout the body. Local placental cytokine production is believed to be important for embryonic growth and in the maternal immune response essential for survival of the pregnancy.<sup>259</sup> Interleukin-1 $\beta$  is produced in the decidualized endometrium during pregnancy, and colony-stimulating factor-1 (CSF-1) is produced by both decidua and placenta. CSF-1 gene expression in response to interleukin-1 $\beta$  has been localized to mesenchymal fibroblasts from the core of placental villi.<sup>260</sup> Thus, a system of communication is present between maternal decidual and fetal tissue to provide growth factor support for the placenta that would include fetal hematopoiesis, a known response to CSF-1. The placenta also produces interleukin-6, and both interleukins stimulate hCG release by activation of the interleukin-6 receptor.<sup>261</sup> Thus, the interleukin-1 influence on hCG secretion is mediated by the interleukin-6 system. Both trophoblast-derived interleukin-1 and tumor necrosis factor- $\alpha$  (TNF- $\alpha$ ) synergistically release interleukin-6 and activate the interleukin-6 system to secrete hCG.<sup>262</sup> Interferons and their receptors are present in virtually all cells, and thus, it is not surprising that they are found in the tissues of pregnancy.

The insulin-like growth factors, IGF-I and IGF-II, are involved in prenatal and postnatal growth and development. These growth factors do not cross the placenta into the fetal circulation; however, they may be involved in placental growth.<sup>263</sup> The maternal levels of IGF-I, which exerts lipolytic effects during pregnancy,<sup>264,265</sup> are significantly regulated by growth hormone-dependent liver synthesis. The fetus can influence maternal IGF-I levels by means of the placental secretion of hPL. An increase in maternal IGF-I levels during pregnancy with a rapid decrease after delivery indicates a significant placental influence. There is no major change in maternal IGF-II levels throughout pregnancy. There is evidence that IGF-II secreted by the placenta is also important for modulating the sensitivity of pancreatic  $\beta$  cells to glucose<sup>266</sup> and maternal insulin and glucose concentrations during pregnancy.<sup>267,268</sup> The six IGF-binding proteins transport IGFs in the circulation, protect IGFs against metabolism and clearance, and, importantly, affect the biologic activity of IGFs by modulating IGF availability at the cellular level. Pregnancy is marked by a rise in maternal levels of insulin-like growth factor-binding protein-1 (IGFBP-1), beginning at the end of the first trimester and reaching a peak at term.<sup>269,270</sup> IGFBP-1 is now recognized to be the same as placental protein-12, a decidual protein. Thus, IGFBP-1 originates in the decidua, regulated by progesterone, as well as in the liver. The prominence of IGFBP-1 in the pregnant state is in contrast to the nonpregnant state when IGFBP-3 is the main circulating IGFBP. During pregnancy, the levels of IGFBP-3 and IGFBP-2 decrease, apparently due to the

activity of a pregnancy-associated serum protease (IGFBP-3 protease).<sup>269</sup> These changes would promote the bioavailability of IGF-I in maternal tissues, and this may be important in enhancing nutrient transfer from the mother to the placenta. There is evidence to indicate that the mother can alter IGFBP-3 proteolytic activity according to her nutritional state; thus, increased proteolysis would decrease IGFBP-3 levels increasing the bioavailability of maternal IGF-I.<sup>271</sup>

In the pregnant ewe and fetal lamb, glucose and other nutritional factors regulate the gene expression and, therefore, the circulating levels of IGF-binding proteins.<sup>272</sup> Fasting and feeding increased and decreased, respectively, the IGFBP concentrations, perhaps partly a response to insulin levels and the effect of insulin on liver synthesis of IGFBPs. These changes are consistent with IGF and IGFBP involvement in the responses to nutrition and stress. Because IGFBP-1 appears to be the principal binding protein in pregnancy, attention is focused on the changes in IGF-I and IGFBP-1. IGF-I, produced in the placenta, regulates transfer of nutrients across the placenta to the fetus and, thus, enhances fetal growth; IGFBP-1, produced in the decidua, interferes with IGF-I action and inhibits fetal growth.<sup>273</sup> Thus, newborn birth weight correlates directly with maternal levels of IGF-I and inversely with levels of IGFBP-1.

Intrauterine growth restriction is associated with reduced fetal blood levels of IGF-I and IGFBP-3 and increased levels of IGFBP-1 and IGFBP-2.<sup>274</sup> In view of the strong relationship between the IGF system and fetal nutrition, it is logical that fetal glucose availability and insulin are the principal regulating agents. In experimental animals, an increase in fetal insulin or glucose elevates IGF-I levels, whereas nutritional restriction causes an increase in IGFBP-1 and IGFBP-2 and a decrease in IGFBP-3.<sup>275</sup> Insulin is believed to influence growth by promoting cellular uptake of nutrients and by increasing IGF-I production. The fetal blood levels of IGF-II parallel those of IGF-I, and IGF-II promotes fetal growth by means of the IGF-I receptor. IGF-II appears to be important early in embryonic growth, and then after organ development is complete, IGF-I becomes the dominant factor.

EGF is present in both cytotrophoblast and syncytiotrophoblast, but more intensely in syncytiotrophoblast, and probably is involved in the differentiation of cytotrophoblast into syncytiotrophoblast. EGF is well known as a mitogen. Other growth factors isolated from human placenta include platelet-derived growth factor, nerve growth factor, fibroblast growth factor, and transforming growth factors. These factors are probably all involved in the proliferation and growth associated with pregnancy.

# Inhibin, Activin, and Follistatin

The placenta produces inhibin, which is responsible for the marked increase in maternal inhibin levels throughout pregnancy.<sup>276,277</sup> Inhibin-A is the principal bioactive inhibin secreted during pregnancy, rising in the maternal circulation at the time of the emergence of placental function, peaking at 8 weeks of gestation, and then decreasing before increasing again in the third trimester to reach a level at term that is 100 times greater than that during the normal menstrual cycle.<sup>278,279,280,281</sup> Undoubtedly, the high levels of inhibin and estrogen during pregnancy account for the profound suppression of maternal gonadotropins. Trophoblastic inhibin synthesis is inhibited by activin-A and stimulated by hCG, GnRH, EGF, transforming growth factor- $\alpha$ , and PGE<sub>2</sub> and PGF<sub>2 $\alpha$</sub> , the major placental prostaglandins.<sup>277</sup> Activin-A, the major trophoblastic activin product, also increases in the maternal circulation, with elevated but stable levels from 8 to 24 weeks, and then increasing to reach a level at term that is also 100 times greater than that during the normal menstrual cycle.<sup>282</sup>

Similar to their action in the ovarian follicle, inhibin and activin are regulators within the placenta for the production of GnRH, hCG, and steroids; as expected, activin is stimulatory, and inhibin is inhibitory.<sup>128</sup> GnRH and the subunits for inhibin and activin can be found in the same placental cells, in both cytotrophoblast and syncytiotrophoblast.<sup>283</sup> The maternal levels of inhibin-B are very low throughout pregnancy; however, inhibin-B is significantly expressed in the amnion where it is believed to influence prostaglandin synthesis.<sup>284</sup> Trophoblast synthesis and release of inhibin and activin are part of the complex placental story, involving many hormones and locally produced factors. The placental and decidual appearance of inhibin and activin occurs early in pregnancy in time for possible roles in embryogenesis and local immune responses. Higher levels of activin-A are found at midgestation in women who subsequently develop pre-eclampsia.<sup>208,285</sup>

Follistatin is the activin-binding protein expressed in placenta, membranes, and decidua.<sup>286</sup> Because follistatin binds activin, it antagonizes the stimulatory effects of activin on placental steroid and peptide production.

# Endogenous Opiates

Fetal and maternal endogenous opiates originate from the pituitary glands and are secreted in parallel with ACTH, in response to CRH, which is, in part, derived from the placenta.<sup>287</sup> There is reason to believe that in pregnancy, the intermediate lobe of the maternal pituitary gland is a major source of elevated circulating endorphin levels. However, the syncytiotrophoblast in response to CRH produces all of the products of POMC metabolism, including  $\beta$ -endorphin, enkephalins, and dynorphins. The placenta and membranes are richly endowed with G protein opioid receptors.<sup>288</sup> The presence of CRH in the placenta and placental opiate production in response to CRH and oxytocin indicate an interaction similar to that in the hypothalamic-pituitary axis.<sup>289</sup>

It is not certain whether maternal blood levels of endogenous opiates increase with advancing gestation.<sup>92</sup> However, a marked increase in maternal values is reached during labor, coinciding with full cervical dilation. The maternal levels also correlate with the degree of pain perception and use of analgesia. On the fetal side, hypoxia is a potent stimulus for endorphin release.

There are many hypotheses surrounding the function of endogenous opiates in pregnancy. These include roles related to stress; inhibition of oxytocin, vasopressin, and gonadotropins; the promotion of prolactin secretion; and, of course, a natural analgesic agent during labor and delivery.



# The Renin-Angiotensin System

The maternal circulating levels of prorenin, the inactive precursor of renin, increase 10-fold during early pregnancy, the result of ovarian stimulation by hCG.<sup>290,291</sup> This increase in prorenin from the ovary is not associated with any significant change in the blood levels of the active form, renin. Possible roles for this ovarian prorenin-renin-angiotensin system include the following: stimulation of steroidogenesis to provide androgen substrate for estrogen production, regulation of calcium and prostaglandin metabolism, and stimulation of angiogenesis. This system may affect vascular and tissue functions both in and outside the ovary. Prorenin also originates in chorionic tissues and is highly concentrated in the amniotic fluid. The highest biologic levels of prorenin are found in gestational sacs in early pregnancy; its possible roles in embryonic growth and development remain speculative.<sup>291</sup> Renin and angiotensinogen (the renin substrate) are expressed by the following fetal tissues: chorion, amnion, and placenta.<sup>292</sup> This system responds to a variety of factors, affecting vascular resistance and blood volume.<sup>293</sup> Maternal renin activity is increased fourfold by midgestation, partly a response to an estrogen-induced increase in angiotensinogen but largely a compensatory response to maintain blood pressure in the presence of vasodilation.<sup>294</sup> There is no evidence that fetal or uterine prorenin or renin contributes to the maternal circulation.

# Atrial Natriuretic Peptide

Atrial natriuretic peptide (ANP) is derived from human atrial tissue and the placenta.<sup>295</sup> It is a potent natriuretic, diuretic, and smooth muscle–relaxant peptide that circulates as a hormone. Maternal ANP increases in the third trimester and during labor, and cord levels on the arterial side suggest that ANP is a circulating hormone in the fetus.<sup>296</sup> In the mother, ANP release is stimulated by atrial stretch, and this is another mechanism for regulating the volume and electrolyte changes associated with pregnancy and delivery.<sup>297</sup> ANP regulates water and electrolyte balance in the fetus as well, and increased amniotic fluid and maternal blood second-trimester levels of ANP have been reported in the presence of fetal cardiac malformations.<sup>298</sup> In mice with a targeted deletion of the natriuretic peptide receptor, hearts are enlarged, and surviving adults have hypertension and cardiac hypertrophy.<sup>299</sup> ANP belongs to a family of natriuretic peptides that have been found in the human uterus. ANP is secreted by myometrial cells and exerts a suppressive effect on myometrial contractions; it is speculated that the expanding uterus may release ANP just as the heart does when the atrium is stretched.<sup>300</sup>

## Other Proteins

The mother responds to a pregnancy even before implantation. Remarkably, early pregnancy factor (EPF) can be detected in the maternal circulation within 1–2 days after coitus results in a pregnancy.<sup>301</sup> It remains throughout pregnancy but, interestingly, disappears before parturition. EPF prior to implantation is apparently produced by the ovary in response to a signal from the embryo. After implantation, EPF is no longer secreted by the ovary but now is derived from the embryo. EPF is a protein associated with cell proliferation and growth and, therefore, is present in many nonpregnant tissues such as neoplasms. EPF has immunosuppressive properties and is abundant in platelets.

Pregnancy-specific  $\gamma_1$ -glycoprotein (PSG) was previously known as Schwangerschaftsprotein 1. The physiologic function of PSG produced by the placenta is unknown, but it has been used as a test for pregnancy and a marker for malignancies, including choriocarcinoma. Molecular studies have revealed that PSG consists of a family of glycoproteins encoded by genes on chromosome 19.<sup>302</sup> The PSG family is closely related to the carcinoembryonic antigen (CEA) proteins.

Placental soluble fms-like tyrosine kinase (sFlt-1) and soluble endoglin (sENG) are circulating receptors for VEGF and PLGF and transforming growth factor- $\beta$  (TGF- $\beta$ ), respectively.<sup>303,304</sup> Soluble Flt-1 and sENG are secreted in large quantities by the placenta resulting in marked elevation in their circulating levels during pregnancy, which steadily rise until term.<sup>303,304</sup> They are almost undetectable in the circulation of nonpregnant individuals. Both sFlt-1 and sENG are found to be increased in sera and placentae of women with pre-eclampsia, and their abnormal elevation predates the development of the syndrome. There is experimental animal evidence that sENG cooperates with sFlt-1 to induce endothelial dysfunction in vitro and pre-eclampsia in vivo.<sup>305</sup> It is thought that sFlt-1 and sENG elevation results in angiogenic imbalance, which in turn leads to endothelial damage and the clinical onset of the syndrome. However, large prospective studies have failed to show sufficient accuracy of these biomarkers for clinical utility in prediction of pre-eclampsia.<sup>306,307,308</sup>

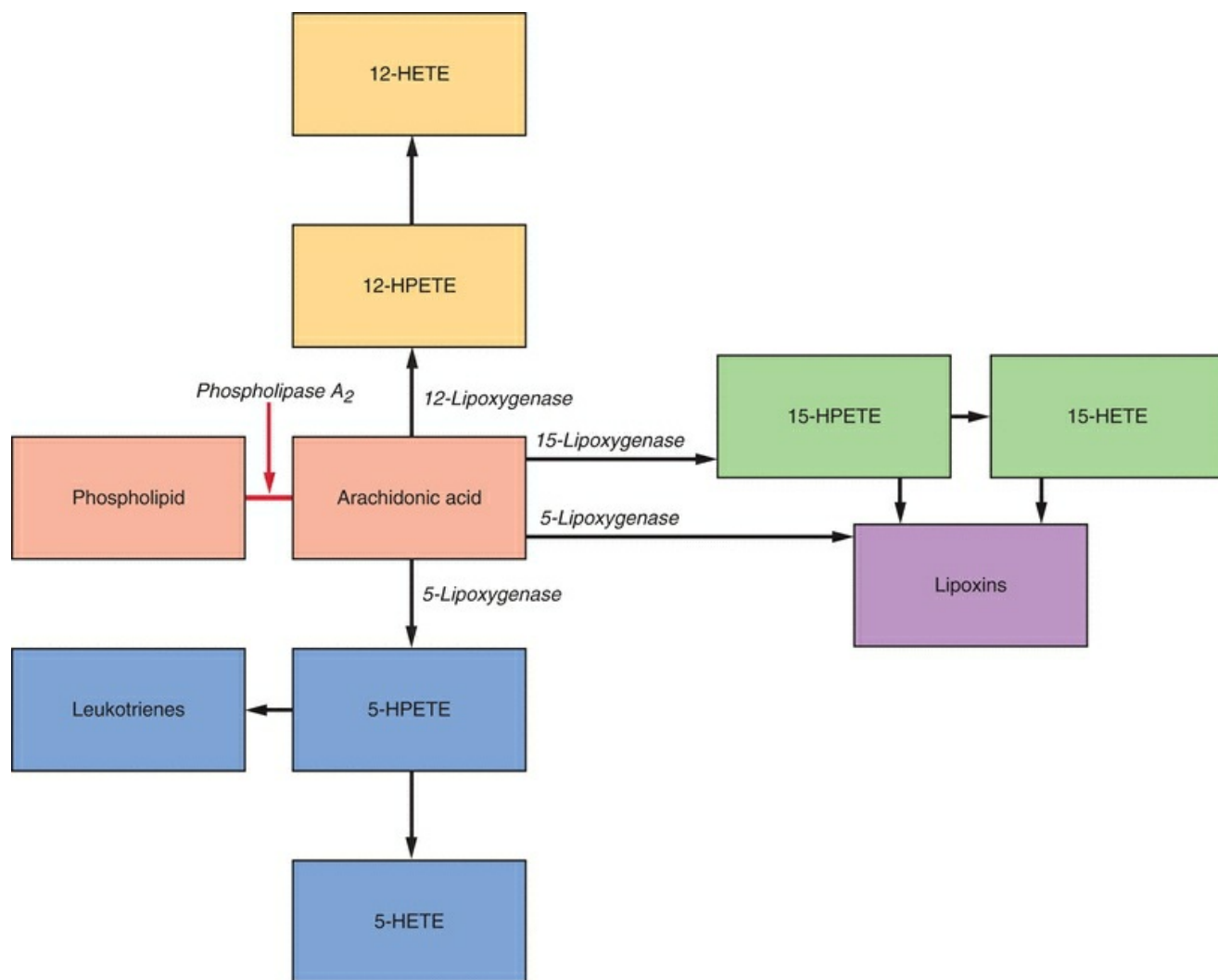
Pregnancy-associated plasma protein-A is a placental protein that is similar to a macroglobulin in the serum, and investigators are still in search of specific functions. Low levels of PAPP-A in the first trimester are associated with adverse obstetrical outcomes.<sup>208</sup> Progesterone-associated endometrial protein, previously called placental protein 14, is now recognized to originate in secretory endometrium and decidua. No role for this protein has been described thus far. Neuropeptide Y, a peptide extensively distributed in the brain, is found in trophoblast, membranes, and decidua, with higher but nonchanging maternal blood levels during pregnancy.<sup>92</sup>

# PROSTAGLANDINS

---

# Prostaglandin Biosynthesis

Prostaglandins are autocrine and paracrine factors produced in almost all cells in the human body. The family of prostaglandins with the greatest biologic activity is that having two double bonds, derived from arachidonic acid.<sup>309,310</sup> Arachidonic acid can be obtained from two sources, directly from the diet (from meats) or by formation from its precursor linoleic acid, which is found in vegetables. In the plasma, 1–2% of the total free fatty acid content is free arachidonic acid. The majority of arachidonic acid is covalently bound in esterified form as a significant proportion of the fatty acids in phospholipids and in esterified cholesterol. Arachidonic acid is only a minor fatty acid in the triglycerides packaged in adipose tissue (**Figure 7.12**).



**FIGURE 7.12**

The rate-limiting step in the formation of the prostaglandin family is the release of free

arachidonic acid. A variety of hydrolases may be involved in arachidonic acid release, but phospholipase A<sub>2</sub> activation is an important initiator of prostaglandin synthesis because of the abundance of arachidonate in the 2 position of phospholipids. In addition, phospholipase C activity can provide arachidonic acid. Types of stimuli that activate such lipases include burns, infusions of hypertonic and hypotonic solutions, thrombi and small particles, endotoxin, snake venom, mechanical stretching, catecholamines, bradykinin, angiotensin, and the sex steroids.

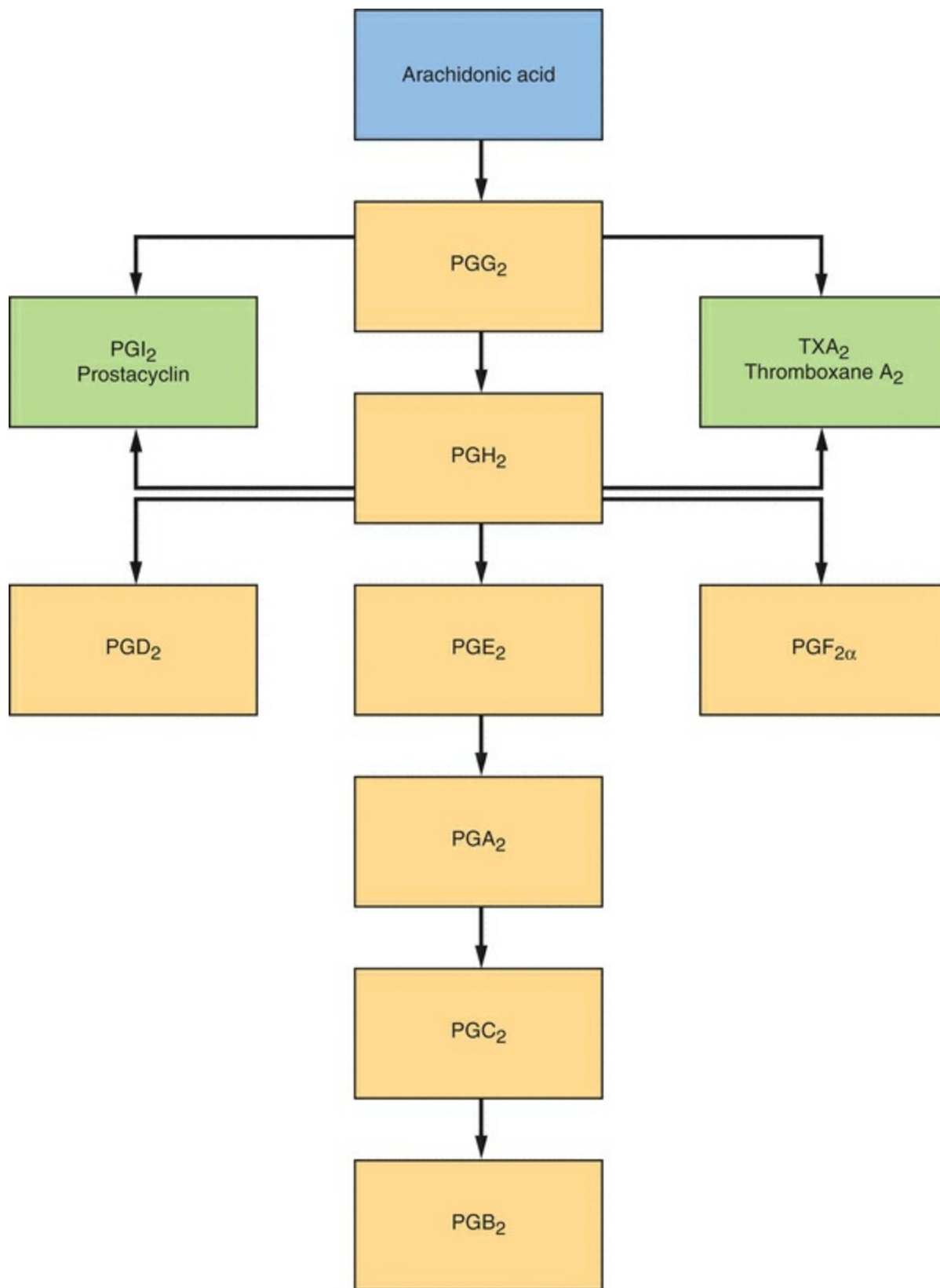
“Eicosanoids” refer to all the 20-carbon derivatives, whereas “prostanoids” indicate only those containing a structural ring. After the release of arachidonic acid, the synthetic path can go in two different directions: the lipoxygenase pathway or the cyclo-oxygenase (prostaglandin endoperoxide H synthase) pathway, depending on the local cellular context. There are three lipoxygenase enzymes that lead to active compounds, predominantly in inflammatory white blood cells. Arachidonic acid is first converted to hydroperoxyeicosatetraenoic acids (HPETEs) and then to hydroxyeicosatetraenoic acids (HETEs), lipoxins, or leukotrienes. The leukotrienes are formed by 5-lipoxygenase oxygenation of arachidonic acid at C-5, forming an unstable intermediate, LTA<sub>4</sub>.<sup>311</sup> LTB<sub>4</sub> is formed by hydration and LTC<sub>4</sub> by the addition of glutathione. The remaining leukotrienes are metabolites of LTC<sub>4</sub>. The previously known “slow-reacting substance of anaphylaxis” consists of a mixture of LTC<sub>4</sub>, LTD<sub>4</sub>, and LTE<sub>4</sub>. The leukotrienes are involved in the defense reactions of white cells and participate in hypersensitivity and inflammatory responses. LTB<sub>4</sub> acts primarily on leukocytes (stimulation of leukocyte emigration from the bloodstream), whereas LTC<sub>4</sub>, LTD<sub>4</sub>, and LTE<sub>4</sub> affect smooth muscle cells (bronchoconstriction in the lungs and reduced contractility in the heart). All leukotrienes increase microvascular permeability. Thus, the leukotrienes are major agonists, synthesized in response to antigens provoking asthma and airway obstruction. Leukotrienes are 100–1,000 times more potent than histamine in the pulmonary airway. Asthma is now treated with specific leukotriene receptor antagonists.

The 12-lipoxygenase pathway leads to 12-hydroxyeicosatetraenoic acid (12-HETE). Little is known about 12-HETE other than its function as a leukostatic agent. The lipoxins (LXA and LXB), products of the 5- and 15-lipoxygenase pathways, inhibit natural killer cell cytotoxicity and are vasodilators.<sup>311</sup>

The cyclo-oxygenase pathway leads to the prostaglandins. The first true prostaglandin (PG) compounds formed are PGG<sub>2</sub> and PGH<sub>2</sub> (half-life of about 5 minutes), the mothers of all other prostaglandins. The numerical subscript refers to the number of double bonds. This number depends on which of the three precursor fatty acids has been utilized. Besides arachidonic acid, the other two precursor fatty acids

are linoleic acid, which gives rise to the PG<sub>1</sub> series, and pentanoic acid, the PG<sub>3</sub> series. The latter two series are of less importance in physiology, hence the significance of the arachidonic acid family. The prostaglandins of original and continuing relevance to reproduction are PGE<sub>2</sub> and PGF<sub>2α</sub> and possibly PGD<sub>2</sub>. The α in PGF<sub>2α</sub> indicates the α steric configuration of the hydroxyl group at the C-9 position. The A, B, and C prostaglandins either have little biologic activity or do not exist in significant concentrations in biologic tissues. In the original work, the prostaglandin more soluble in ether was named PGE, and the one more soluble in phosphate (spelled with an F in Swedish) buffer was named PGF. Later, naming became alphabetical.

The cyclo-oxygenase enzyme (prostaglandin synthase) exists in two forms, COX-1 and COX-2, products of separate genes.<sup>312,313,314</sup> Prostacyclin is produced by COX-1, the constitutive form of the enzyme found in virtually all tissues, whereas COX-2 is induced in responses to inflammatory stimuli. COX-2 is expressed only after stimulation by various growth factors, cytokines, hormones, and endotoxins; therefore, it is called the inducible form. Thus, selective inhibition of COX-2 would possibly be therapeutically advantageous, avoiding the side effects associated with inhibition of COX-1 (**Figure 7.13**).

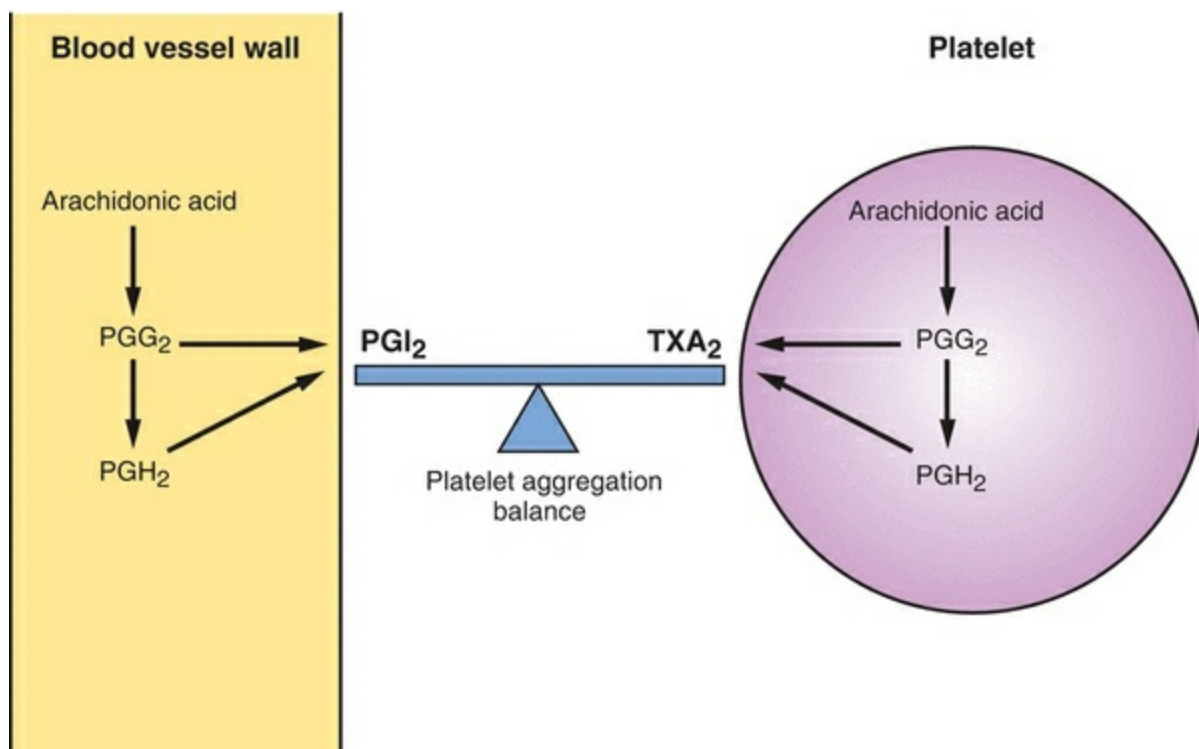


**FIGURE 7.13**



# Thromboxane and Prostacyclin

Thromboxanes are not true prostaglandins because of the absence of the pentane ring, but prostacyclin ( $\text{PGI}_2$ ) is a legitimate prostaglandin. Thromboxane (TX) (half-life about 30 seconds) and  $\text{PGI}_2$  (half-life about 2–3 minutes) can be viewed as opponents, each having powerful biologic activity that counters or balances the other.  $\text{TXA}_2$  is the most powerful vasoconstrictor known, whereas  $\text{PGI}_2$  is a potent vasodilator. These two agents also have opposing effects on platelet function. Platelets, lungs, and the spleen predominately synthesize  $\text{TXA}_2$ , whereas the heart, stomach, and blood vessels throughout the body synthesize  $\text{PGI}_2$ . The lungs are a major source of prostacyclin. Normal pulmonary endothelium makes prostacyclin, whereas  $\text{TXA}_2$  appears in response to pathologic stimuli.<sup>315</sup> The pulmonary release of prostacyclin may contribute to the body's defense against platelet aggregation (**Figure 7.14**).



**FIGURE 7.14**

Let us take a closer look at platelets. The primary function of platelets is the preservation of the vascular system. Blood platelets stick to foreign surfaces or other tissues, a process called adhesion. They also stick to each other and form clumps; this process is called aggregation. Because platelets synthesize  $\text{TXA}_2$ , a potent stimulator of

platelet aggregation, the natural tendency of platelets is to clump and plug defects and damaged spots. The endothelium, on the other hand, produces PGI<sub>2</sub>, and its constant presence inhibits platelet aggregation and adherence, keeping blood vessels free of platelet aggregates and ultimately clots. Thus, prostacyclin has a defensive role in the body. It is 4–8 times more potent a vasodilator than the E prostaglandins, and it prevents the adherence of platelets to healthy vascular endothelium. However, when the endothelium is damaged, platelets gather, beginning the process of thrombus formation. Even in this abnormal situation, prostacyclin strives to fulfill its protective role because increased PGI<sub>2</sub> can be measured in injured endothelium, in thrombosed vessels, and in the vascular tissues of hypertensive animals.

It is believed that endothelial production of prostacyclin plays an important role in the impressive vasodilation that is associated with pregnancy. The placenta is a major source of thromboxane, and pre-eclampsia may, in part, reflect an imbalance between the vasodilator, prostacyclin, and the vasoconstrictor, thromboxane.<sup>316</sup>

Conditions associated with vascular disease can be understood through the prostacyclin-thromboxane mechanism. For example, atheromatous plaques and nicotine inhibit prostacyclin synthesis. Increasing the cholesterol content of human platelets increases the sensitivity to stimuli that cause platelet aggregation due to increased thromboxane production. The well-known association between low-density and high-density lipoproteins (HDLs) (LDL cholesterol and HDL cholesterol) and cardiovascular disease may also be partly explained in terms of PGI<sub>2</sub>. LDL from men and postmenopausal women inhibits, and HDL stimulates prostacyclin production.<sup>317</sup> Platelets from diabetic pregnant women make more TXA<sub>2</sub> than platelets from normal pregnant women. Smokers who use oral contraceptives have increased platelet aggregation and an inhibition of prostacyclin formation.<sup>318</sup> Incidentally, onion and garlic inhibit platelet aggregation and TXA<sub>2</sub> synthesis.<sup>319</sup> Perhaps the perfect contraceptive pill is a combination of progestin, estrogen, and some onion or garlic.

In some areas of the world, there is a low incidence of cardiovascular disease. This can be directly attributed to diet and the protective action of prostacyclin.<sup>320</sup> The diet of Eskimos and Japanese has a high content of pentanoic acid and low levels of linoleic and arachidonic acids. Pentanoic acid is the precursor of prostaglandin products with three double bonds, and, as it happens, PGI<sub>3</sub> is an active agent, whereas TXA<sub>3</sub> is either not formed or inactive. The fat content of most common fish is 8–12% pentanoic acid and more than 20% in the more exotic (and expensive) seafoods such as scallops, oysters, and caviar.

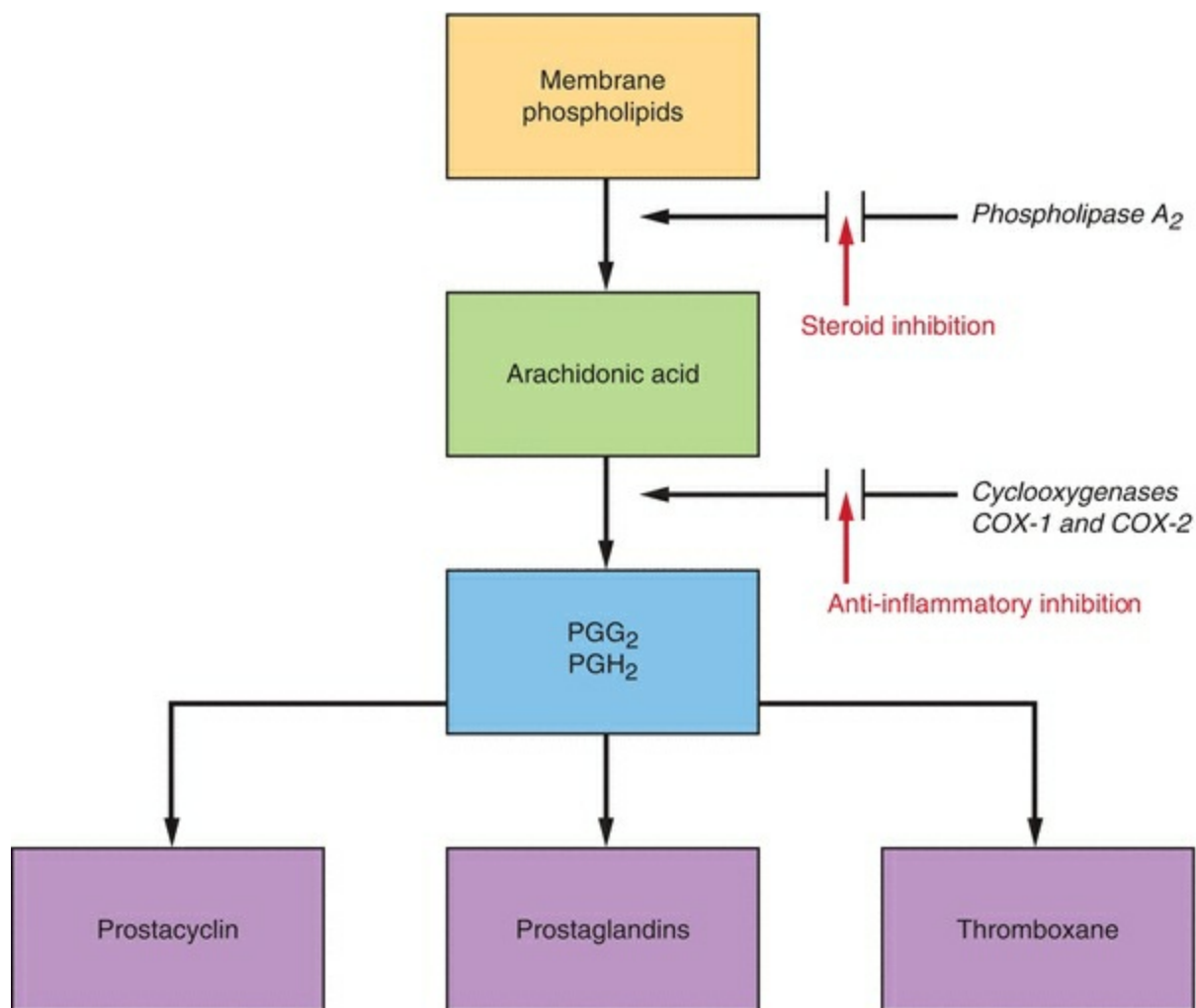
# Metabolism

Prostaglandin metabolism is initiated by 15-hydroxyprostaglandin dehydrogenase. The metabolism of prostaglandins occurs primarily in the lungs, kidneys, and liver. The lungs are important in the metabolism of E and F prostaglandins. Indeed, there is an active transport mechanism that specifically carries E and F prostaglandins from the circulation into the lungs. Nearly all active prostaglandins in the circulation are metabolized during one passage through the lungs. Therefore, members of the prostaglandin family have a short half-life and, in most instances, exert autocrine/paracrine actions at the site of their synthesis. Because of the rapid half-lives, studies are often performed by measuring the inactive end products, for example, 6-keto-PGF<sub>1α</sub>, the metabolite of prostacyclin, and TXB<sub>2</sub>, the metabolite of thromboxane A<sub>2</sub>.

# Prostaglandin Inhibition

A review of prostaglandin biochemistry is not complete without a look at the inhibition of the biosynthetic cascade of products. Corticosteroids were thought to inhibit the prostaglandin family by stabilizing membranes and preventing the release of phospholipase. It is now proposed that corticosteroids induce the synthesis of proteins called lipocortins (or annexins), which block the action of phospholipase.<sup>321</sup> Thus far, corticosteroids and some local anesthetic agents are the only substances known to work at this step. Because corticosteroids reduce the availability of arachidonic acid for both the lipoxygenase and cyclo-oxygenase pathways, they are very effective anti-inflammatory agents and antihypersensitivity agents, especially for the treatment of asthma.

Aspirin is an irreversible inhibitor, selectively acetylating the cyclo-oxygenase involved in prostaglandin synthesis. The other inhibiting agents, nonsteroidal anti-inflammatory drugs (NSAIDs) such as indomethacin and naproxen, are reversible agents, forming a reversible bond with the active site of the enzyme. Acetaminophen inhibits cyclo-oxygenase in the central nervous system, accounting for its analgesic and antipyretic properties, but it has no anti-inflammatory properties and does not affect platelets. However, acetaminophen does reduce prostacyclin synthesis; the reason for this preferential effect is unknown.<sup>322</sup> The analgesic, antipyretic, and anti-inflammatory actions of these agents are mediated by inhibition of the cyclo-oxygenase enzymes, COX-1 and COX-2. Aspirin, indomethacin, and ibuprofen are more potent inhibitors of COX-1 than COX-2.<sup>323</sup> Diclofenac, acetaminophen, and naproxen inhibit both enzymes equally. The side effects associated with each agent are a reflection of the degree of selectivity toward the two enzymes; inhibition of COX-1, the constitutive form, is associated with significant side effects, and inhibition of COX-2, the inducible form, is potentially therapeutic for pain and inflammation. Part of the anti-inflammatory activity of glucocorticoids is due to inhibition of COX-2 formation. The well-known gastric ulcerogenic side effect of anti-inflammatory drugs is due to the fact that PGE<sub>2</sub> protects the gastric mucosa by inhibiting gastric acid secretion, and COX-1 is the predominant enzyme in the gastric mucosa. The specific inhibitors of COX-2 are effective analgesics with a better gastrointestinal side effect profile (**Figure 7.15**).



**FIGURE 7.15**

Efficacy in treating dysmenorrhea is similar compared to the older agents with the newer specific COX-2 inhibitors. Theoretically, the COX-2 inhibitors should avoid the unwanted inhibition of prostaglandin activity in the process of ovulation; however, in the mouse, it is the COX-2 enzyme that is involved in ovulation, and rofecoxib delayed ovulation in a small trial of women.<sup>324,325</sup>

Because of the irreversible nature of the inhibition by aspirin, aspirin exerts a long-lasting effect on platelets, maintaining inhibition in the platelet for its life span (8–10 days). Prostacyclin synthesis in the endothelium recovers more quickly because the endothelial cells can resynthesize new cyclo-oxygenase. Platelets, lacking nuclei, cannot produce new enzyme, probably exclusively COX-1. The sensitivity of the platelets to aspirin may explain the puzzling results in the early studies in which aspirin was given to prevent subsequent morbidity and mortality following thrombotic events. It takes only a little aspirin to effectively inhibit thromboxane synthesis in platelets. Going beyond this dose will not only inhibit thromboxane synthesis in platelets but also inhibit

the protective prostacyclin production in blood vessel walls. Some suggest that a dose of 3.5 mg/kg (about half an aspirin tablet) given at 3-day intervals effectively induces maximal inhibition of platelet aggregation without affecting prostacyclin production by the vessel walls.<sup>326</sup> Others indicate that the dose that effectively and selectively inhibits platelet cyclo-oxygenase is 20–40 mg daily.<sup>327,328</sup> The major handicap with the use of inhibitors of PG synthesis is that they strike blindly and with variable effects from tissue to tissue. Obviously, drugs that selectively inhibit TXA<sub>2</sub> synthesis would be superior to aspirin in terms of antithrombotic effects.

A concern with the specific COX-2 inhibitors is their inhibition of prostacyclin formation, whereas COX-1 generation of TXA<sub>2</sub> is unaffected. Unfortunately, arterial thrombotic events, including myocardial infarction and stroke, are about twofold increased in users of COX-2 inhibitors, raising appropriate caution, especially in individuals at high risk for cardiovascular disease.<sup>329</sup> It is not certain that nonselective, traditional NSAIDs don't share this cardiovascular risk.

# THE ENDOCRINOLOGY OF PARTURITION

---

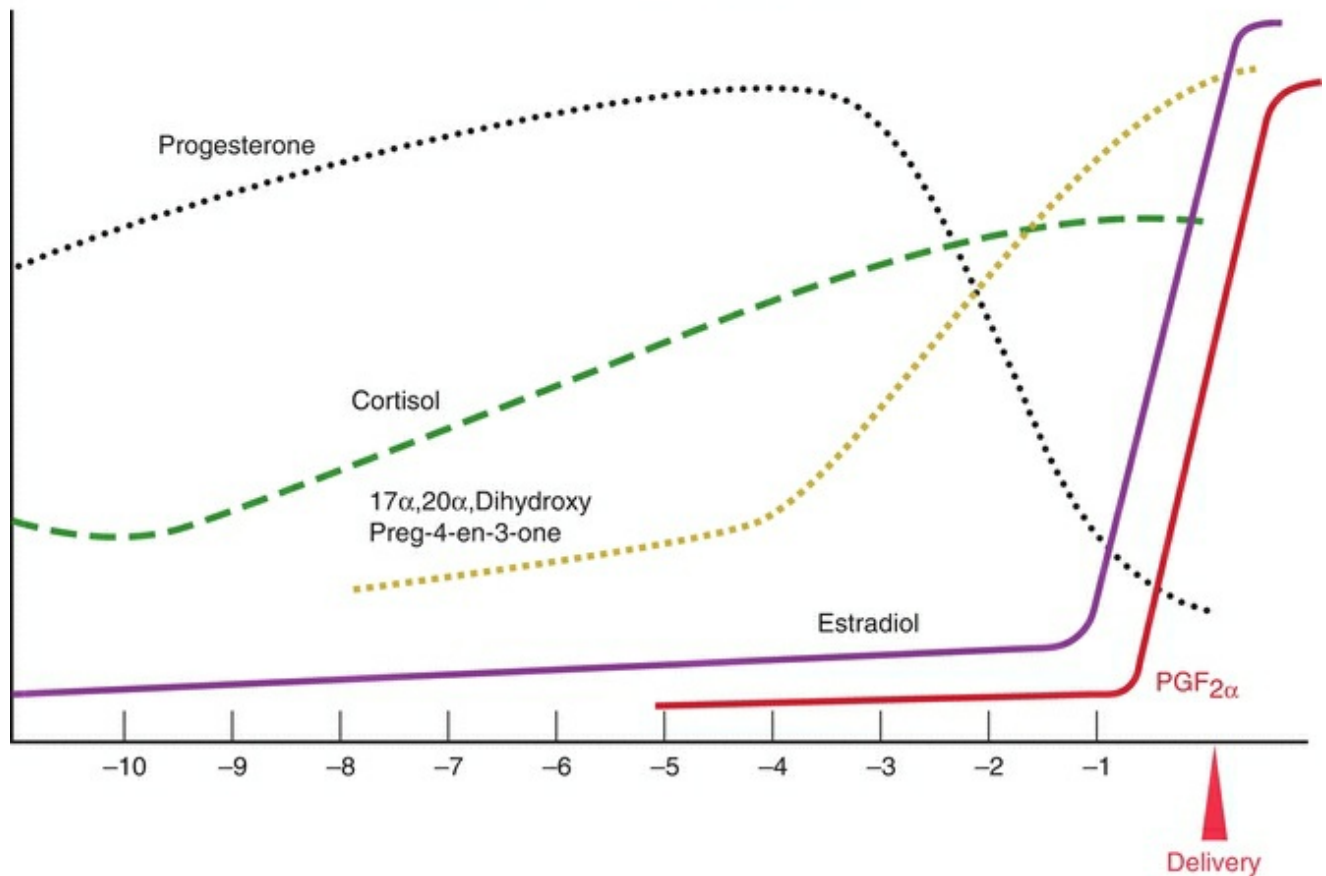
The timing of birth is a crucial determinant of perinatal outcome. Both preterm birth (defined as delivery before 37 weeks of gestation) and postterm pregnancy (failure to deliver before 42 weeks) are linked to higher risk of adverse pregnancy events. It has long been thought that the fetoplacental unit is in charge of the timing of parturition.<sup>330,331</sup> While this appears to be true in some species, despite intensive investigations spanning many decades, a precise mechanism of such a “placental clock” has yet to crystallize in humans. It has now become apparent that the endometrium/decidua also plays a central role in initiating the cascade of events culminating in human birth.<sup>332</sup>

Perhaps the best example of the interplay among fetus, placenta, and mother is the initiation and maintenance of parturition. Hormonal changes in the uteroplacental environment are the principal governing factors accounting for the eventual development of uterine contractions. The sequence of events has been repeatedly reviewed in detail, where references to the original work are available.<sup>333,334,335,336,337,338,339</sup>

Extensive work in sheep has implicated the fetal pituitary-adrenal axis in normal parturition. The sequence of events in the ewe begins about 10 days prior to labor with elevation of fetal cortisol in response to fetal pituitary ACTH, in turn a response to increased release of hypothalamic CRH. Fetal adrenalectomy or hypophysectomy prolongs pregnancy, whereas infusion of ACTH or glucocorticoids into the sheep fetus stimulates premature labor. Maternal stimulation of the fetal adrenal is not a factor because in sheep (and in women) there is little or no placental transfer of maternal ACTH into the fetal circulation. Thus, parturition in the ewe is initiated by a signal in the fetal brain activating ACTH secretion.

Increased cortisol secretion by the fetal adrenal gland starts a chain of events associated with labor. The sequence of events continues in the ewe with a decline in progesterone. This change is brought about by the induction of 17 $\alpha$ -hydroxylase, 17,20-lyase enzyme activity (P450c17) in the placenta (**Figure 7.16**). The up-regulation of P450c17 may be mediated by PGE<sub>2</sub>. COX-2 activity is stimulated by cortisol, while at the same time, cortisol inhibits the activity of 15-hydroxyprostaglandin dehydrogenase. An increase in PGE<sub>2</sub> correlates with the increasing activity of P450c17.

## Changes in Sheep Pregnancy



**FIGURE 7.16**

Glucocorticoid treatment of sheep placental tissue specifically increases the rate of production of 17 $\alpha$ ,20 $\alpha$ -dihydroxypreg-4-en-3-one. This dihydroxyprogesterone compound also has been identified in sheep placental tissue obtained after spontaneous labor. Thus, direct synthesis of progesterone does not decline, but increased metabolism to a 17 $\alpha$ -hydroxylated product results in less available progesterone. Progesterone withdrawal is associated with a decrease in the resting potential of myometrium, that is, an increased response to electric and oxytocic stimuli. Conduction of action potential through the muscle is increased, and the myometrial excitability is increased.

Dihydroxyprogesterone also serves as a precursor for the rise in estrogen levels, which occurs a few days prior to parturition. Estrogens enhance rhythmic contractions, as well as increase vascularity and permeability and the oxytocin response. Thus, progesterone withdrawal and estrogen increase lead to an enhancement of conduction and excitation.

The final event in the ewe is a rise in PGF<sub>2 $\alpha$</sub>  production hours before the onset of uterine activity. A cause-and-effect relationship between the rise in estrogen and the



appearance of  $\text{PGF}_{2\alpha}$  has been demonstrated in sheep. These events indicate that the decline in progesterone, the rise in estrogen, and the increase in  $\text{PGF}_{2\alpha}$  are all secondary to direct induction of a placental enzyme by fetal cortisol.

# Human Parturition

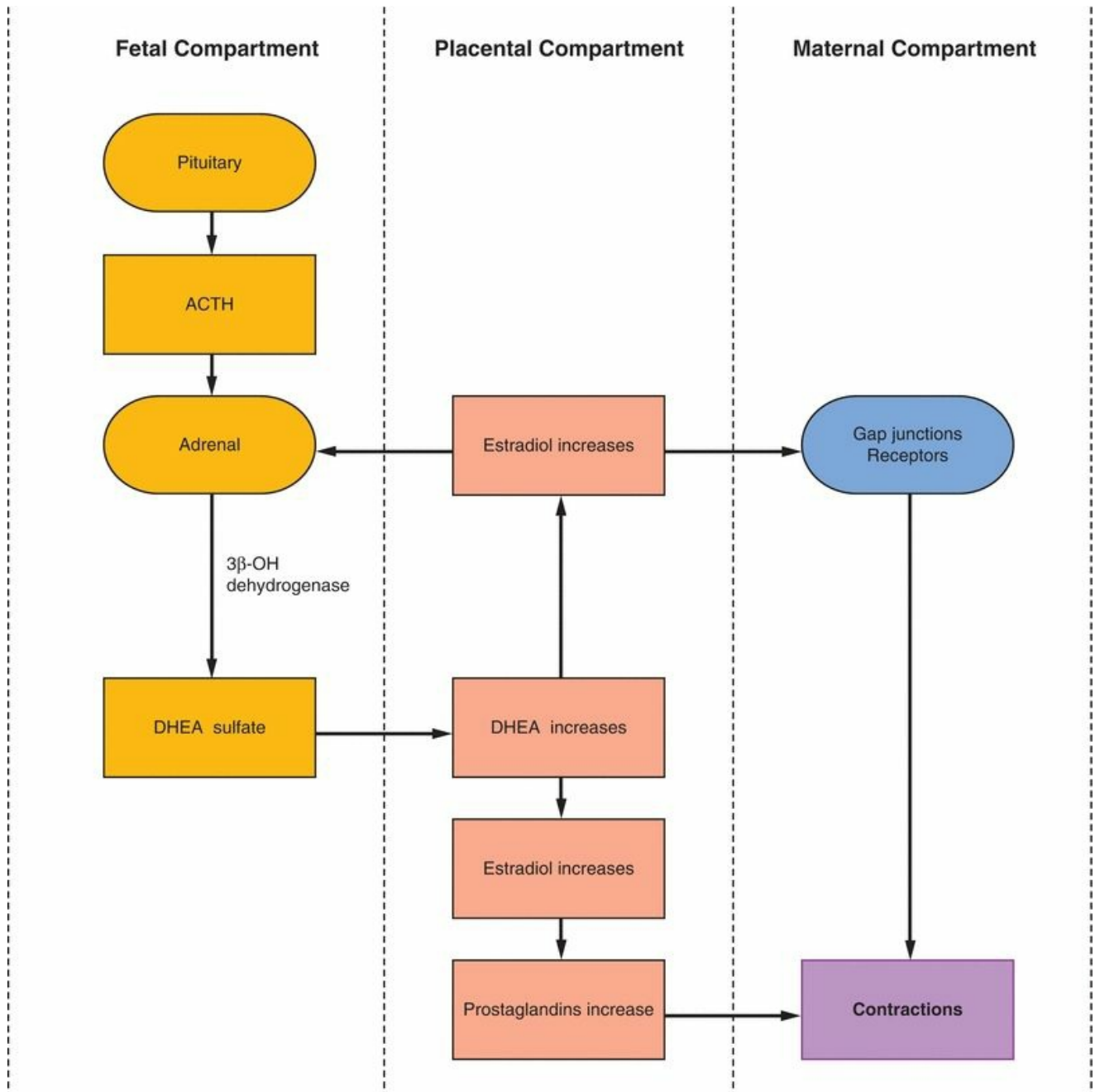
The control of pregnancy and parturition is very species specific. The mechanisms involved in human pregnancy maintenance and parturition are highly complex and involve both maternal and fetal systems. There is no simple chain of events as there are in other species. The steroid events in human pregnancy are not identical to events in the ewe, chiefly because placental P450c17 enzyme activity is absent. In addition, there is a more extended time scale. Steroid changes in the ewe occur over the course of several days, whereas in human pregnancy the changes begin at approximately 34–36 weeks and occur over the last 5 weeks of pregnancy. However, if the time course is expressed as a percentage of gestational length, the percentages in sheep and primates are impressively comparable.

Cortisol rises dramatically in amniotic fluid, beginning at 34–36 weeks, and correlates with pulmonary maturation. Cord blood cortisol concentrations are high in infants born vaginally or by cesarean section following spontaneous onset of labor. In contrast, cord blood cortisol levels are lower in infants born without spontaneous labor, whether delivery is vaginal (induced labor) or by cesarean section (elective repeat section). In keeping with the extended time scale of events, administration of glucocorticoids is not followed acutely by the onset of labor in pregnant women (unless the pregnancy is past due).

It is unlikely that the cortisol increments in the fetus represent changes due to increased adrenal activity in the mother in response to stress. Although maternal cortisol crosses the placenta readily, it is largely (85%) metabolized to cortisone in the process. This, in fact, may be the mechanism by which suppression of the fetal adrenal gland by maternal cortisol is avoided. In contrast to the maternal liver, the fetal liver has a limited capacity for transforming the biologically inactive cortisone to the active cortisol. On the other hand, the fetal lung does possess the capability of changing cortisone to cortisol, and this may be an important source of cortisol for lung maturation. Cortisol itself induces this conversion in lung tissue. Increased fetal adrenal activity is followed by changes in steroid levels, as well as important developmental accomplishments (e.g., increased pulmonary surfactant production and the accumulation of liver glycogen). In human parturition, an important contribution of the fetal adrenal, in addition to cortisol, is its effect on placental estrogen production. The common theme in human pregnancies associated with failure to begin labor on time is decreased estrogen production, for example, delayed parturition in anencephaly or placental sulfatase deficiency.<sup>340</sup>

Progesterone maintenance of uterine quiescence and increased myometrial excitability associated with progesterone withdrawal are firmly established as mechanisms of parturition in lower species (**Figure 7.17**). In primates, the role of

progesterone has been less certain, largely because of the inability to demonstrate a definite decline in peripheral blood levels of progesterone prior to parturition.<sup>341</sup> Nevertheless, pharmacologic treatment with progesterone or synthetic progestational agents has some effect in preventing premature labor, although not labor at term.<sup>342,343,344,345</sup> There is also reason to believe that progesterone concentration is regulated locally, especially in the fetal membranes, and progesterone withdrawal can be accomplished by a combination of binding, metabolism, and changes in receptor isoform levels, as well as changes in coactivating and corepressing proteins.<sup>346</sup>



**FIGURE 7.17**

In the myometrium, during advancing gestation and with parturition, overall progesterone receptor concentration does not change with the onset of labor; however, a shift in receptor isoforms occurs with a dominance of progesterone receptor-A and other isoforms of the progesterone receptor other than receptor-B (progesterone receptor-C, another truncated isoform, is expressed in the myometrium, decidua, and membranes).<sup>347,348,349,350,351</sup> **Because progesterone receptor-A mainly suppresses progesterone receptor-B activity (the principal mediator of genomic progestational action), this change is consistent with a local withdrawal of progesterone in the myometrium. Therefore, there is growing reason to believe that a functional progesterone withdrawal occurs in primates, keeping the mechanism of parturition evolutionarily consistent. This withdrawal of progesterone occurs not only in the myometrium but also in the decidua and the fetal membranes.**

Because progesterone receptor-B activity suppresses estrogen receptor expression, a shift to progesterone receptor-A would simultaneously allow both progesterone withdrawal and an increase in estrogen activity.<sup>348</sup> This further indicates that the process of parturition begins before the onset of contractions. Prostaglandin involvement continues to be an integral part of this process; prostaglandin F<sub>2α</sub> stimulates progesterone receptor-A expression in myometrial cells studied in vitro, a response consistent with the emerging dominance of progesterone receptor-A before parturition.<sup>352</sup>

Progesterone receptor concentrations in the monkey amnion change in the presence of labor, consistent with activation of prostaglandin and cytokine production in the membranes following functional progesterone withdrawal.<sup>347</sup> In a fashion similar to human myometrium, progesterone receptor-A levels in monkey myometrium increase in late gestation and during labor. Interruption of exposure to progesterone (e.g., with the antiprogesterone, RU-486) leads to uterine contractions.<sup>353</sup> Furthermore, inhibition of progesterone production in the second trimester of human or the third trimester of monkey pregnancies is followed by a decrease in maternal, fetal, and amniotic fluid progesterone concentrations and preterm labor and delivery.<sup>354,355</sup> Perhaps, multiple mechanisms exist, which affect in a subtle fashion the local concentration and actions of progesterone and the production of progesterone in fetal membranes allowing redundant pathways to compensate when a specific pathway is compromised.<sup>356</sup> Coactivator and corepressor proteins are known to modulate the responsiveness of steroid hormone target tissues. Appropriate changes in intracellular regulatory proteins would be another potential method to modulate progesterone activity in pregnant tissues.<sup>357</sup>

An increase in estrogen levels in maternal blood begins at 34–35 weeks of gestation, but a late increase just before parturition (as occurs in the ewe) has not been

observed in human pregnancy. Perhaps, a critical concentration is the signal in human pregnancy rather than a triggering increase. Or the changes are taking place at a local level and are not reflected in the maternal circulation.<sup>358</sup> Although it has not been definitely demonstrated, increased or elevated estrogen levels, as well as a local withdrawal of progesterone production, are thought to play a key role in increasing prostaglandin. As with progesterone, the change in estrogen may be a functional increase at the local tissue level, such as an increase in estrogen receptor concentration and/or activity. Given the central role in parturition for progesterone withdrawal in all species, the local estrogen change could be secondary to the functional progesterone withdrawal, such as the change in progesterone receptor-A expression, allowing estrogen receptor gene expression to escape progesterone inhibition.<sup>348</sup>

The concept of a functional progesterone withdrawal in primate parturition and the obvious importance of progesterone withdrawal in other species prompted extensive study of the administration of progestational drugs to prevent preterm labor. There is some effect with progesterone itself, 100 mg/daily administered vaginally, but there is a one-third reduction in preterm birth with 17 $\alpha$ -hydroxyprogesterone caproate given as a weekly 250-mg injection.<sup>359,360</sup> These results have been obtained in women at high risk for preterm birth by virtue of a previous preterm birth. Progestational therapy is ineffective once labor has begun, and the impact on pregnancies complicated by conditions associated with premature labor is unknown, although studies have indicated no reduction in preterm birth in women with twin or triplet gestations.<sup>361,362,363</sup> Multiple clinical trials are ongoing.

## Key Points: Evidence for a Role of Prostaglandin in Parturition

- Prostaglandin levels in maternal blood and amniotic fluid increase in association with labor.
- Arachidonic acid levels in the amniotic fluid rise in labor, and arachidonate injected into the amniotic sac initiates parturition.
- Patients taking high doses of aspirin have a highly significant increase in the average length of gestation, incidence of postmaturity, and duration of labor.
- Indomethacin prevents the normal onset of labor in monkeys and stops premature labor in human pregnancies.
- Stimuli known to cause the release of prostaglandins (cervical manipulation, stripping of membranes, and rupture of membranes) augment or induce uterine contractions.

- The process of cervical ripening and softening is mediated by prostaglandins.
- Exogenously administered prostaglandins induce labor.

The precursor fatty acid for prostaglandin production in part may be derived from storage pools in the fetal membranes, the decidua, or both.<sup>321</sup> Phospholipase A<sub>2</sub> has been demonstrated in both human chorioamnion and uterine decidua. The availability of arachidonic acid for prostaglandin production during parturition follows the stimulation of hydrolysis of phosphatidylethanolamine and phosphatidylinositol in decidual, amnion, and chorion laeve tissues.<sup>364,365,366</sup> Microsomes from amnion, chorion laeve, and decidua vera tissues contain lipases that hydrolyze fatty acids esterified in the 2 position. Specific phospholipase activity (phospholipase A<sub>2</sub> acting on phosphatidylethanolamine and phospholipase C acting on phosphatidylinositol) combined with a DAG lipase that also has a specificity for arachidonic acid provides a mechanism for the release of arachidonic acid. The activity of these enzymes in fetal membranes and decidua vera tissue increases with increasing length of gestation.

The key may be the increasing levels of estrogen (both estradiol and estriol) in the maternal circulation as well as in the amniotic fluid or, more importantly, locally within the uterus. The marked rise in estrogen near term may affect the activity of the lipase enzymes, leading to the liberation of arachidonic acid. The activity of these phospholipases is increased by increasing concentrations of calcium; and, therefore, the regulation of intracellular calcium is an important mechanism. Nevertheless, a role for local progesterone withdrawal in the activation of prostaglandin production remains a likely mechanism.<sup>355</sup>

Cervical ripening is the process by which the cervix becomes soft and distensible and easily dilated. This change is associated with a decrease in collagen and proteoglycans, and an increase in water, brought about by enzymes and cytokines in response to prostaglandins. Progesterone is believed to exert a stabilizing influence on the cervix during pregnancy, a state that is antagonized by estrogen. Studies of enzyme activity within human cervical tissue indicate that prior to the initiation of labor, progesterone levels are maintained in the cervix, whereas estrogen becomes inactivated.<sup>367</sup> With the onset of parturition, 17 $\beta$ -hydroxysteroid dehydrogenase is decreased, resulting in an increase in the local concentrations of estradiol and a metabolite of progesterone, 20 $\alpha$ -hydroxyprogesterone (in effect, a local cervical withdrawal of progesterone). These changes are consistent with local responses to increasing estrogen levels and support the general mechanism of progesterone withdrawal occurring at localized tissue sites.

The human fetal membranes and decidua are incredibly active. Human chorion and

decidua produce estrogen utilizing a variety of substrates, especially estrone sulfate and DHEAS, and this activity is increased around the time of parturition.<sup>368,369</sup> In addition, the human fetal membranes synthesize and metabolize progesterone.<sup>16</sup> The membranes contain a 17,20-hydroxysteroid dehydrogenase system. One active site converts 20 $\alpha$ -dihydroxyprogesterone to progesterone, while another active site on this enzyme converts estrone to estradiol. Thus, this enzyme can play an important role in altering the estrogen/progesterone ratio. The membranes and the decidua contain distinct cell populations with different biochemical activities (which change with labor).<sup>370</sup> Steroidogenic and prostaglandin interactions among these cells could produce the changes necessary for parturition without affecting the concentrations of circulating hormones. In addition, relaxin derived from decidua and/or chorion may exert a paracrine action on amnion prostaglandin production.<sup>227</sup> Throughout most of pregnancy, the amnion and chorion may exert an inhibitory influence over the myometrium by suppressing calcium channel activity.<sup>371</sup> Finally, the fetus may take a very direct role in this scenario by secreting substances into the amniotic fluid, which interact with the fetal membranes to signal the initiation of parturition.

## Key Points: Observations of Placental Corticotropin-Releasing Hormone (CRH)

- CRH is produced in trophoblast, the fetal membranes, and decidua.<sup>92</sup>
- During pregnancy, CRH levels in the amniotic fluid and the maternal circulation progressively increase, and although amniotic fluid levels do not further increase with labor, the highest maternal levels are found at labor and delivery.
- Levels of the CRH-binding protein are decreased in trophoblast, membranes, decidua, the amniotic fluid, and maternal circulation prior to labor.<sup>370,372,373</sup> This decrease in the CRH-binding protein would allow an increase in CRH activity.
- CRH directly stimulates DHEA and DHEAS biosynthesis in cells derived from the fetal zone of the adrenal.<sup>57</sup>
- CRH stimulates prostaglandin release in fetal membranes, decidua, and myometrium.<sup>108,374</sup>
- Increased CRH and decreased CRH-binding protein have been measured in women with preterm labor and in women with threatened preterm labor who subsequently deliver within 24 hours.<sup>330,375,376,377</sup>
- Cortisol, in the presence of progesterone, stimulates (probably by blocking progesterone inhibition) trophoblastic CRH synthesis.<sup>55,378</sup>
- CRH, activin A, vasopressin, and prostaglandin F<sub>2 $\alpha$</sub>  stimulate oxytocin release

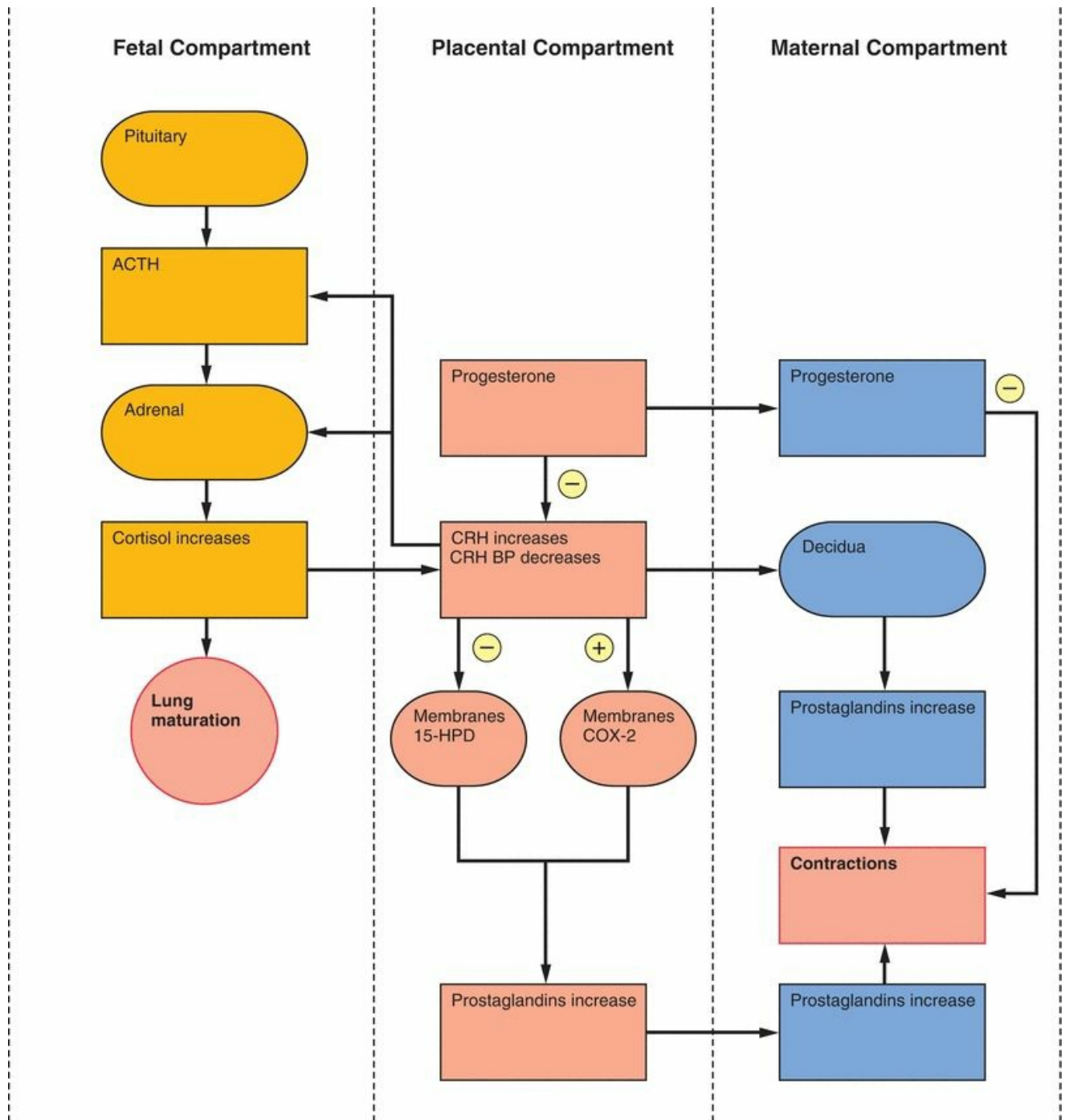
from placental tissues, to augment myometrial contractions.<sup>379</sup>

- CRH increases the secretion of matrix metalloproteinases in placental cells and fetal membranes, a prelude to the rupture of membranes.<sup>110</sup>

These observations are consistent with a key mechanism involving CRH activity in the initial triggering events of parturition. Although in the ewe the CRH signal begins in the fetal brain, in women, it appears to begin in the uterus. Indeed, placental CRH is expressed in primate placentas.<sup>380</sup> Progesterone and estrogen are major inhibiting factors for CRH production in placental tissue.<sup>381</sup> It has been hypothesized that rising fetal cortisol levels (e.g., in response to stress, especially hypoxia) compete with progesterone for the glucocorticoid receptor in the placenta, thus blocking the inhibitory action of progesterone on CRH synthesis, leading to an increase in CRH.<sup>55</sup>

**Cortisol directly stimulates CRH gene expression in the placenta, providing a mechanism for a specific link between cortisol and CRH.**<sup>382</sup> Because CRH directly stimulates steroidogenesis in the fetal zone of the adrenal, the increase in CRH would increase DHEAS to serve as precursor for the increase in estrogen that occurs prior to parturition. The sequence of events could be started by an increase in CRH or a decrease in CRH-binding protein, or both, associated with the estrogen and progesterone changes in late pregnancy (estrogen and progesterone receptor-A repress and progesterone receptor-B increases CRH gene expression).<sup>383,384</sup> On the other hand, consistent with the sheep studies, the initiating step in this sequence of events could be an increase in fetal ACTH secretion, for example, in response to stress and relative hypoxemia and an increase in placental CRH (**Figure 7.18**). Although CRH plays a central role, various pathways can lead to its increase, another example of multiple pathways to parturition. Regardless of the specific triggering event, it is increasingly clear that the fetus plays a pivotal, if not controlling, role in parturition.





**FIGURE 7.18**

## Regulation of Prostaglandins

It is clear that suppression of prostaglandin production in the uterus is required for pregnancy maintenance and eventual success. The levels of prostaglandins in the decidua are 200-fold lower in pregnancy than in the endometrium at any stage of the menstrual cycle, persisting throughout most of pregnancy. This appears to be caused by a decrease in prostaglandin synthesis and not an increase in prostaglandin

breakdown.<sup>385</sup> Moreover, in all species examined and at any gestational age, exogenous prostaglandin administration has the ability to induce abortion,<sup>386,387</sup> and failure to suppress prostaglandin production in the endometrium at the time of implantation is associated with spontaneous abortion.<sup>388</sup>

With labor, the arachidonic acid pathway in the fetal membranes shifts toward the cyclo-oxygenase direction with a large increase in the production of PGE<sub>2</sub> due to the induction of COX-2 activity. This COX-2 activity is a response to the increase in cortisol that in turn is a response to CRH. In addition, CRH can directly stimulate prostaglandin production in the membranes.

Specific protein inhibitors of prostaglandin synthase have been demonstrated in placenta, amnion, and chorion, and these proteins cannot be found in tissue from patients who have established labor.<sup>321,389</sup> The link between infection and the onset of labor (especially preterm labor) may be due to the conversion by bacterial medium (with inflammatory factors such as the interleukins) of arachidonic metabolism in the membranes and decidua to a condition associated with labor marked by the production of PGE<sub>2</sub>.<sup>321,390,391</sup> In this case, prostaglandin production may be a consequence of inflammatory induction of the second cyclo-oxygenase enzyme COX-2.<sup>392</sup> In addition, intra-amniotic infection is associated with a loss of the chorionic high concentration of 15-hydroxyprostaglandin dehydrogenase that inactivates prostaglandins, resulting in a shift that favors biosynthesis and activity.<sup>393</sup> These changes are modulated by the cytokines involved in the inflammatory response.

Prostaglandin production during pregnancy reflects the usual complex interaction of a host of autocrine/paracrine factors. Platelet-activating factor, EGF, and transforming growth factor- $\alpha$  stimulate prostaglandin production by the fetal membranes apparently by regulating intracellular calcium concentrations.<sup>394,395</sup> Secretory products of the fetal membranes themselves are active stimulators of membrane prostaglandin production, including renin derived from chorion prorenin.<sup>396</sup> Decidual PGF<sub>2 $\alpha$</sub>  production is enhanced by bradykinin, EGF, and transforming growth factor- $\alpha$ , and these responses are further increased by interleukin-1 $\beta$ .<sup>397,398</sup> Prostaglandin production by amnion, chorion, and decidual cells is stimulated by CRH and modulated by progesterone.<sup>107</sup> The ubiquitous substances, activin and inhibin, are involved here as well. Amnion and chorion produce the activin and inhibin subunits, and activin stimulates prostaglandin PGE<sub>2</sub> release from amnion cells.<sup>284</sup>

During labor, the maternal circulating levels of PGE<sub>2</sub>, PGF<sub>2 $\alpha$</sub> , and the PGF<sub>2 $\alpha$</sub>  metabolite are increased, a change that can be directly attributed to uterine production because the gradient across the uterus for these substances is also increased. This

increase in production of prostaglandins within the uterus must be the key factor, because the concentration and affinity of prostaglandin receptors do not change at parturition.<sup>399</sup> Prostacyclin is produced (at least in vitro) by a variety of tissues involved in pregnancy: endometrium, myometrium, placenta, amnion, chorion, and decidua. Prostacyclin and thromboxane are probably more important in the vascular responses of mother and fetus and in all likelihood do not play a role in initiating or maintaining uterine contractions; however, prostacyclin does inhibit myometrial contractility.<sup>400</sup> PGI synthase expression appropriately decreases in myometrium with increasing gestational age.<sup>401</sup>

Decidua produces both PGE<sub>2</sub> and PGF<sub>2α</sub>, but the amnion and chorion produce primarily PGE<sub>2</sub>.<sup>402</sup> The inducible cyclo-oxygenase, COX-2, is expressed at a high level at term in the amnion and chorion.<sup>403</sup> As in sheep, prostaglandin synthesis in membranes and decidua is probably stimulated by cortisol; glucocorticoid receptors are present in the same cells that contain cyclo-oxygenase.<sup>404</sup>

There is evidence for the transfer of prostaglandin E<sub>2</sub> across the membranes to the decidua and possibly the myometrium.<sup>405</sup> The paradox of PGE<sub>2</sub> production in the amnion being matched not by a PGE metabolite in the maternal circulation but by a PGF<sub>2α</sub> metabolite was explained by transfer across the membranes and conversion of PGE<sub>2</sub> to PGF<sub>2α</sub> in the decidua.<sup>406</sup> However, continued study of this issue strongly indicates that prostaglandins produced on one side of the membranes do not contribute to the prostaglandins on the other side, arguing that uterine contractions must be primarily influenced by decidual or myometrial prostaglandins.<sup>407</sup> Indeed, COX-2 expression in the myometrium increases at term before the onset of labor and is correlated with estrogen receptor-α activity.<sup>348</sup> There is reason to believe that the myometrial exposure to prostaglandins is also influenced by the activity of a catabolic enzyme in the chorion.

At term, prostaglandin synthesis occurs in the amnion and decidua, and throughout pregnancy, the chorion forms a barrier preventing passage of bioactive prostaglandins to the myometrium because of a large capacity to catabolize prostaglandins via 15-hydroxyprostaglandin dehydrogenase.<sup>393,408</sup> The activity of this enzyme is decreased in the presence of labor, including preterm labor, and after premature rupture of membranes or when infection is present.<sup>393,409,410</sup>

**Because the activity of 15-hydroxyprostaglandin dehydrogenase decreases in the myometrium and the chorion during labor, a combination of increased biosynthesis of prostaglandins and a decrease in 15-hydroxyprostaglandin dehydrogenase achieves the increase in prostaglandins associated with parturition,**

**probably mediated by the local changes in estrogen and progesterone bioavailability and activity, with key roles also played by CRH and cortisol.** Cortisol decreases and progesterone increases 15-hydroxyprostaglandin dehydrogenase activity in placental tissues.<sup>411,412</sup> A functional withdrawal of progesterone would allow a greater effect of cortisol resulting in an increase in prostaglandins. Regulation of intracellular calcium ions contributes to this mechanism; an influx of calcium ions increases prostaglandin synthase expression, whereas prostaglandin dehydrogenase expression is suppressed.<sup>413</sup> This is a potential pathway for the input of locally produced peptides involved in parturition.

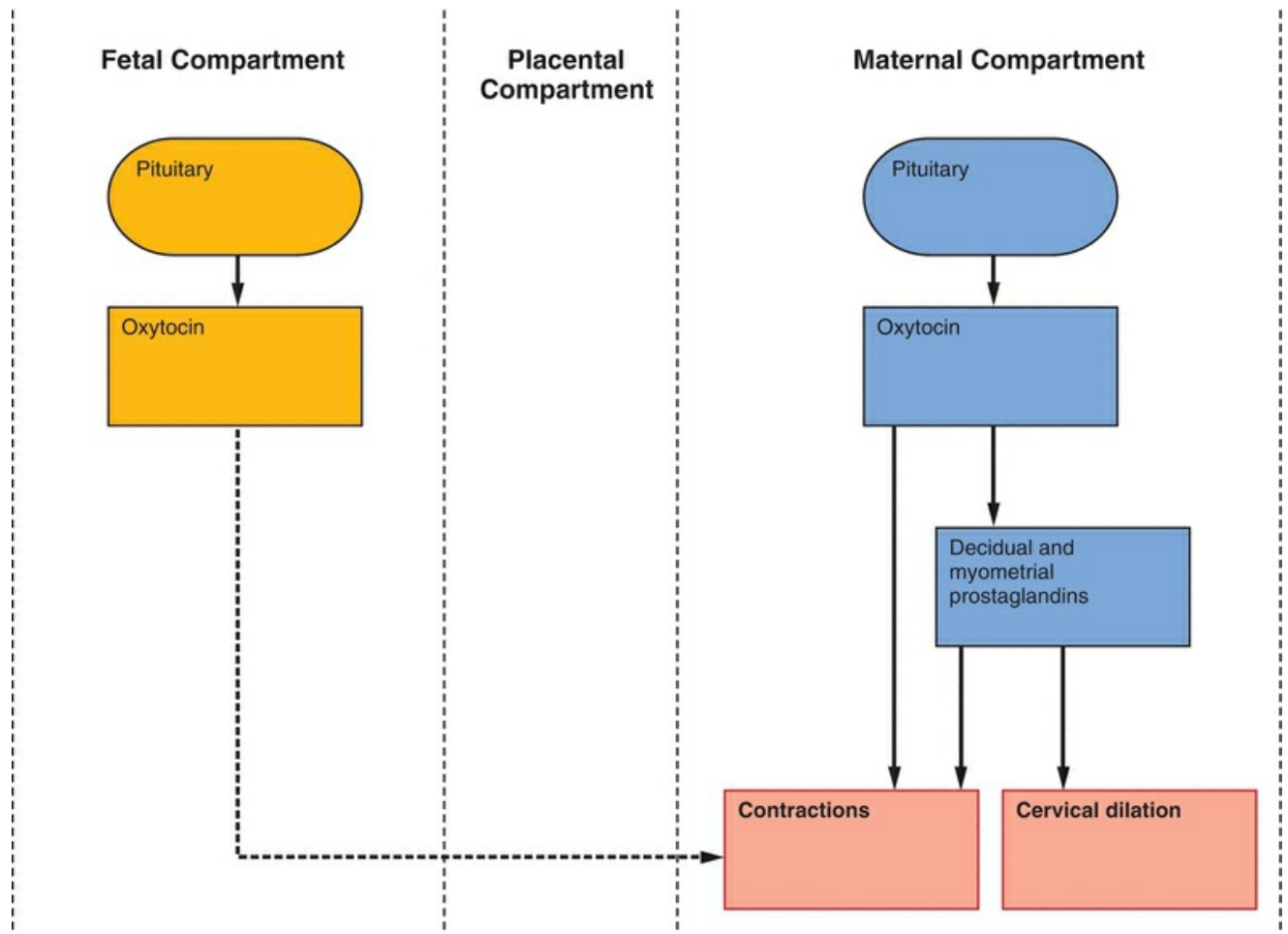
## **Metalloproteinases**

Disruption and remodeling of the extracellular matrix are part of the process of parturition just as it is in implantation and placentation. Cervical ripening, rupture of the fetal membranes, and detachment of the placenta all involve activity of the matrix metalloproteinases in the decidua and the membranes.<sup>414</sup> A balance between these enzymes and their inhibitors is necessary to maintain the integrity of fetal membranes and uterine structure and function. With the change in function associated with parturition, one would expect this balance to shift toward metalloproteinase expression and activity, and, indeed, this is the case.<sup>415</sup> An early event in premature labor and premature rupture of membranes is the activation of the metalloproteinases. There is evidence to indicate that metalloproteinases are activated by prostaglandins and cytokines and inhibition is maintained by down-regulation of the conversion of plasminogen to plasmin by progesterone.<sup>416</sup>

## **Oxytocin and Myometrial Responses**

Using sensitive assays, an increase in maternal levels of oxytocin can be detected prior to parturition, occurring at first only at night.<sup>417,418</sup> Activation of oxytocin secretion is linked to progesterone withdrawal because brainstem oxytocin neurons are suppressed by brain metabolites of progesterone.<sup>419</sup> Once labor has begun, oxytocin levels rise significantly, especially during the second stage (**Figure 7.19**). Thus, maternal oxytocin may be most important for developing the later, more intense uterine contractions. Extremely high concentrations of oxytocin can be measured in the cord blood at delivery, and release of oxytocin from the fetal pituitary may also be involved in labor. However, this is controversial, and studies in monkeys fail to indicate a role for fetal oxytocin in parturition.<sup>418</sup> Part of the contribution of oxytocin to parturition is the stimulation of prostaglandin synthesis in decidua and myometrium.<sup>420</sup> Cervical dilation appears to be dependent on oxytocin stimulation of prostaglandin production, probably

in the decidua. The greater frequency of labor and delivery at night may be due to greater nocturnal oxytocin secretion. In addition, oxytocin is synthesized in the amnion, in the chorion, and, significantly, in the decidua.<sup>417,421,422</sup> This locally produced oxytocin, in response to CRH, may be a significant stimulus for myometrial and membrane production of prostaglandins.

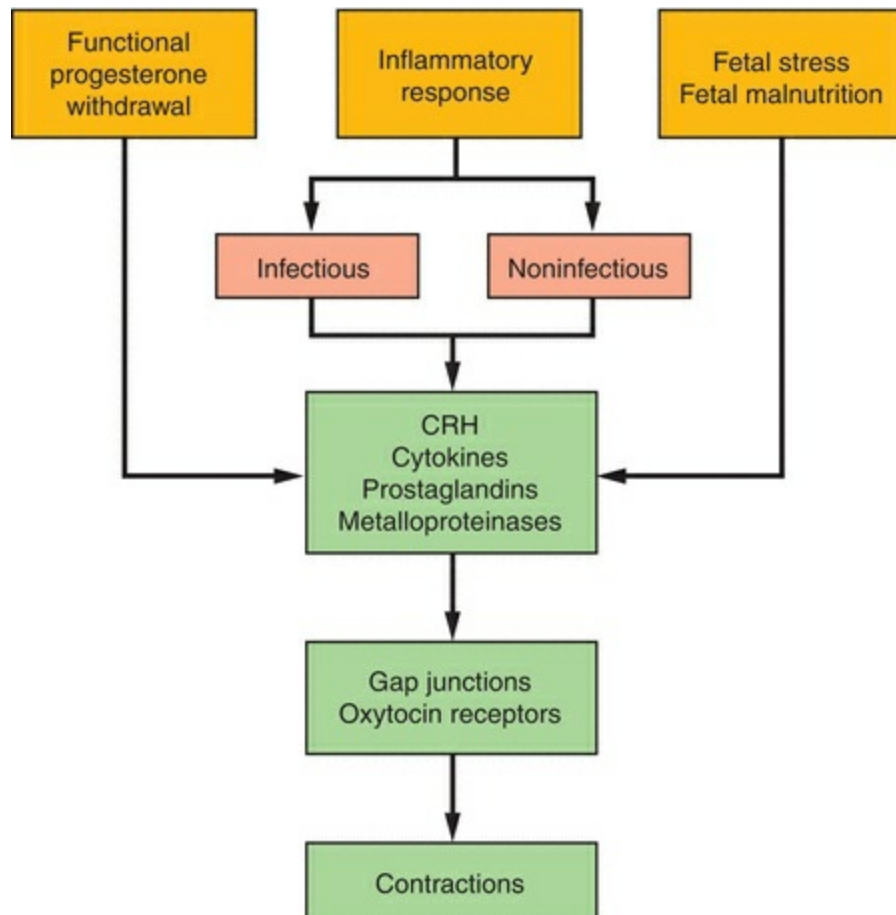


**FIGURE 7.19**

It is likely that oxytocin action during the initial stages of labor may depend on myometrial sensitivity to oxytocin in addition to the levels of oxytocin in the blood. The concentration of oxytocin receptors in the myometrium is low in the nonpregnant state and increases steadily throughout gestation (an 80-fold increase), and during labor, the concentration doubles.<sup>423</sup> The mechanism for the increase is unknown, but it likely is due to a change in the prostaglandin and hormonal milieu of the uterus, especially functional progesterone withdrawal. The local production and effects of oxytocin, estrogen, and progesterone combine in a complicated process of autocrine, paracrine,

and endocrine actions to result in parturition.

Animal studies have implicated the formation of low-resistance pathways in the myometrium, called **gap junctions**, as an important action of steroids and prostaglandins during labor.<sup>424</sup> In the gap junction, a pore forms, which allows communication from cytoplasm to cytoplasm between two cells (**Figure 7.20**). The pore is a cylinder-shaped channel formed of six special proteins called **connexins**. Either substances or electrical current (ions) can follow this pathway without leakage into extracellular space. Thus, gap junctions provide a means of communication between myometrial cells, allowing enhancement of electrical conductivity and synchronization of activity. Gap junction formation is related to the estrogen/progesterone ratio (estrogen up-regulates connexin-43, the gap junction protein, which is down-regulated by progesterone) and to the presence of the stimulating prostaglandins PGE<sub>2</sub> and PGF<sub>2α</sub>. Therefore, it is not surprising that the number of gap junctions increases in the final weeks of pregnancy, especially just before labor. The modulation of the number and the permeability of gap junctions are another contributing factors in the control of uterine contractility.



**FIGURE 7.20**

The final contraction of the uterine muscle results from increased free calcium concentrations in the myofibril, the result of prostaglandin action and functional progesterone withdrawal, an effect opposed to the promotion of calcium binding in the sarcoplasmic reticulum by the presence of progesterone.<sup>425,426</sup> Thus, prostaglandins and oxytocin increase, while progesterone decreases intracellular calcium levels. The intracellular calcium concentration is affected by cellular entry and exit of calcium as well as binding in the sarcoplasmic reticulum. It is the intracellular concentration of calcium that determines the rate of myosin phosphorylation and the contractile state of the myometrium. Tocolytic therapy (the use of  $\beta$ -adrenergic agents) stimulates adenylate cyclase activity, which increases the levels of cellular cyclic AMP, which, in turn, decreases intracellular calcium concentration and inhibits actin-myosin interaction by modulating kinase phosphorylation.

Ducsay and colleagues propose that the coordination of this complex relationship of physiologic, endocrine, and molecular mechanisms is expressed in rhythms.<sup>75,427</sup> Both mother and fetus experience 24-hour rhythms in hormone secretions, and uterine activity is correlated with day and night (photoperiod regulation). The coordination and enhancement of this rhythmicity play a role in parturition. Improved detection and measurement of this activity could contribute to better prevention and treatment of preterm labor.

Molecular biology is now assessing the activity of genes in the uterus and fetal membranes.<sup>428</sup> Some of this activity is predictable, correlating with autocrine and paracrine substances known to be involved in parturition. The identification of other genes differentially regulated during parturition will open new areas for research. Ultimately, we will come to understand the mechanisms of normal parturition and to be more effective in managing premature and abnormal labor.

## Concluding Thought

Imagine yourself as a fetus within a pregnant uterus. Your growth, development, and survival require keeping the uterus quiescent for most of the pregnancy. This is accomplished by maintaining progesterone inhibitory dominance of the myometrium. When ready to begin extrauterine life or when your environment becomes inhospitable, you are able to prepare or “activate” the parturition mechanisms by means of hormonal and autocrine/paracrine messengers. Ultimately, uterine contractions and cervical ripening are stimulated, and amazingly, even if you are incapable of initiating these events, the sequence will eventually begin, and delivery will ensue. The extraordinary experience and wonder of labor and birth, as perceived by parents and birth assistants, are matched by your ability and the complexity of the systems you influence.

# Treatment of Labor with Prostaglandin Inhibition

The key role for prostaglandins in parturition raises the potential for treatment of premature labor with inhibitors of prostaglandin synthesis. The concern has been that such treatment would result in intrauterine closure of the ductus arteriosus causing pulmonary hypertension. Clinical studies, however, indicate that use of the nonsteroidal anti-inflammatory agents for short periods of time (3 days) yields good results and does not result in this complication.<sup>429</sup> Beyond 34 weeks, the fetus is more sensitive to this pulmonary action, and treatment should be limited to pregnancies less than 32 weeks and with caution from 32 to 34 weeks. If the drug is failing, it should not be maintained because increased blood loss can occur at delivery. Because indomethacin inhibits the synthesis of all members of the prostaglandin family, including the vasodilating prostacyclin, it should be used with caution in hypertensive patients.<sup>430</sup> Sulindac is just as effective as a tocolytic but does not affect urine output and amniotic fluid, and it has a lesser impact on the fetal ductus arteriosus.<sup>431,432</sup> A specific COX-2 inhibitor, celecoxib, was as effective as indomethacin in treating preterm labor, but importantly, there was no adverse impact on the ductus arteriosus and there was a lesser transient decrease in amniotic fluid volume.<sup>433,434</sup>

Treatment of pregnant women with indomethacin reduces the amniotic fluid volume due to a decrease in fetal urine output. This is reversible with a decrease in dose. This treatment has been used for polyhydramnios with good response and no effect on the newborn despite treatment for 2–11 weeks.<sup>435,436,437</sup>



# Induction of Labor and Cervical Ripening

Pharmacologically and physiologically, prostaglandins have two direct actions associated with labor: ripening of the cervix and myometrial stimulation. Successful parturition requires organized changes in both the upper uterus and in the cervix. The cervical changes are in response to the estrogen/progesterone ratio and the local release of prostaglandins. Whether relaxin plays a role in human parturition is not established; however, recombinant relaxin is being tested for cervical ripening.

Ripening of the cervix is the result of a change that includes an increase in hyaluronic acid and water and a decrease in dermatan sulfate and chondroitin sulfate (these compounds hold the collagen fibers in a rigid structure). How prostaglandins operate in this change is unknown, but enzyme activation must be involved. For ripening of the cervix, PGE<sub>2</sub> is very effective, whereas PGF<sub>2α</sub> has little effect. The purpose of pharmacologically achieving ripening of the cervix is to increase the success rate with induction of labor and lower the proportion of cesarean sections. Intravaginal prostaglandin E<sub>2</sub> (dinoprostone) administered as tablets and suppositories and mixed in gels has been very effective for cervical ripening. A synthetic PGE<sub>1</sub> analogue, misoprostol, is also effective when used intravaginally or orally for cervical ripening and labor induction, although there can be a problem of uterine tachysystole (rapid contractions).<sup>438,439,440,441</sup>

A major clinical application for the induction of labor in the United States is the use of intravaginal PGE<sub>2</sub> in cases of fetal demise and anencephalic fetuses. The patient should be well hydrated with an electrolyte solution to counteract the induced vasodilation and decreased peripheral resistance. If satisfactory uterine activity is established, the next application should be withheld. And, finally, because there is a synergistic effect when oxytocin is used shortly after prostaglandin administration, there should be a minimum of 6 hours between the last prostaglandin dose and beginning of oxytocin augmentation.

Prostaglandins are used to induce term labor. Intravenous prostaglandins are not an acceptable method due to the side effects achieved by the high dosage necessary to reach the uterus. The intravaginal and oral administration of PGE<sub>2</sub> is as effective as intravenous oxytocin, with good results initially reported even in patients with previous cesarean sections.<sup>442,443</sup> Later, concern was raised that uterine rupture may be more frequent with prostaglandin use in women with previous cesareans.<sup>444</sup> The intravaginal administration of misoprostol, the synthetic prostaglandin E<sub>1</sub> analogue, is safe, effective, and relatively inexpensive for the routine induction of labor.<sup>445</sup> These methods, plus intracervical administration, are in routine use in many parts of the world.

# Induced Abortion

Prostaglandins are effective for postcoital contraception and first-trimester abortion but impractical because of the high incidence of side effects, including an unacceptable rate of incomplete abortions. For midtrimester abortions, intra-amniotic prostaglandin, intramuscular methyl esters, and vaginal PGE suppositories are available. Again, the major clinical problems have been the efficacy in accomplishing complete expulsion and the high level of systemic side effects. Overall, there is a higher risk of hemorrhage, fever, infection, antibiotic administration, readmission to the hospital, and more operative procedures when compared with saline abortions.

The combination of prostaglandin's oxytocic action with the antiprogestosterone effect of RU 486 (mifepristone) has proved to be a safe and effective medical treatment for the induction of therapeutic abortion in both the first and second trimesters.<sup>446,447,448,449</sup> Combining a prostaglandin analogue, misoprostol, with mifepristone inexpensively and safely achieves greater than 95% efficacy ([Chapter 21](#)).

# Prostaglandins and Postpartum Hemorrhage

When routine methods of management for postpartum hemorrhage caused by uterine atony have failed, an analogue of prostaglandin  $F_{2\alpha}$  gives excellent results (80–90% successful).<sup>450</sup> Prostin 15 M is 15(S)-15-methyl prostaglandin  $F_{2\alpha}$ -tromethamine. The dose is 0.25–0.5 mg, repeated up to 4 times and given with equal efficacy either intramuscularly or directly into the myometrium. It can also be used after the replacement of an inverted uterus. Failures are usually associated with infections or magnesium sulfate therapy. However, clinical trials with injectable prostaglandins have indicated that regular methods are as effective and that the modest reduction in blood loss does not warrant routine use to prevent postpartum hemorrhage.<sup>451</sup> When used after delivery for the prevention of postpartum hemorrhage, misoprostol, the  $PGE_1$  analogue, 600 mg given orally, is less effective with more side effects than the standard use of oxytocin.<sup>451,452</sup> However, misoprostol can be a lifesaver when delivery and hemorrhage occur in parts of the world where parenteral drugs are not available.

# PROSTAGLANDINS AND THE FETAL CIRCULATION

---

The predominant effect of prostaglandins on the fetal and maternal cardiovascular system is to maintain the ductus arteriosus and the renal, mesenteric, uterine, placental, and probably the cerebral and coronary arteries in a relaxed or dilated state. The importance of the ductus arteriosus can be appreciated by considering that 59% of the cardiac output flows through this connection between the pulmonary artery and the descending aorta.

Control of ductal patency and closure is mediated through prostaglandins. The arterial concentration of oxygen is the key to the caliber of the ductus. With increasing gestational age, the ductus becomes increasingly responsive to increased oxygen. In this area, too, attention has turned to PGI<sub>2</sub> and TXA<sub>2</sub>.

Fetal lamb ductus homogenates produce mainly PGI<sub>2</sub> when incubated with arachidonic acid. PGE<sub>2</sub> and PGF<sub>2α</sub> are formed in small amounts and TXA<sub>2</sub> not at all. Although PGE<sub>2</sub> is less abundant than PGI<sub>2</sub> in the ductus, it is a more potent vasodilator of the ductus and is more responsive to oxygen (decreasing vasodilation with increasing oxygen).<sup>453</sup> Thus, PGE<sub>2</sub> appears to be the most important prostaglandin in the ductus from a functional point of view, whereas PGI<sub>2</sub>, the major product in the main pulmonary artery, appears to be the major factor in maintaining vasodilation in the pulmonary bed. The ductus is dilated maximally in utero by production of prostaglandins, and a positive vasoconstrictor process is required to close it. The source of the vasoconstrictor is probably the lung. With increasing maturation, the lung shifts to TXA<sub>2</sub> formation. This fits with the association of ductal patency with prematurity. With the onset of pulmonary ventilation at birth leading to vascular changes that deliver blood to the duct directly from the lungs, TXA<sub>2</sub> can now serve as the vasoconstrictor stimulus. The major drawback to this hypothesis is the failure of inhibitors to affect the constriction response to oxygen.

Administration of vasodilating prostaglandins can maintain ductal patency after birth while preparing an infant for surgery to correct a congenital lesion causing pulmonary hypertension.<sup>454</sup> Infants with persistent ductus patency may be spared from thoracotomy by treatment with an inhibitor of prostaglandin synthesis. The use of indomethacin to close a persistent ductus in the premature infant is successful about 40% of the time.<sup>453,455</sup> Ibuprofen is equally effective and reduces blood flow to critical organs less than that observed with indomethacin.<sup>456</sup> An important factor is early diagnosis and treatment because with increasing postnatal age the ductus becomes less

sensitive to prostaglandin inhibitors, probably because of more efficient clearance of the drug.<sup>457</sup> The highest incidence of successful ductus closure has been with infants younger than 30 weeks of gestation and younger than 10 days old.

This aspect of the use of prostaglandin inhibitors is of concern in considering the use of agents to inhibit premature labor. The drug half-life in the fetus and newborn is prolonged because the metabolic pathways are limited, and there is reduced drug clearance because of immature renal function. In utero constriction of the ductus can cause congestive heart failure and fetal pulmonary hypertension.<sup>458</sup> Prolonged ductus constriction leads to subendocardial ischemia and fibrotic lesions in the tricuspid valve muscles. Infants with persistent pulmonary hypertension have hypoxemia, cardiomegaly, and right-to-left shunting through the foramen ovale or the ductus. Infants of mothers given either indomethacin or salicylates chronically have been reported to have this syndrome. Duration of exposure and dosage are critical. It takes occlusion of the ductus for more than 2 weeks to produce fetal pulmonary hypertension and cardiac hypertrophy. This side effect is rare in pregnancies less than 27 weeks of gestation; the ductus arteriosus usually begins to respond at 27–30 weeks, and after 30 weeks, this is an important side effect that can be minimized if long-term use is avoided.<sup>459</sup>

# PROSTAGLANDINS AND FETAL BREATHING

---

Prior to parturition, fetal breathing is very shallow. It is proposed that placental PGE<sub>2</sub> suppresses breathing by acting in the fetal brain.<sup>460</sup> Occlusion of the umbilical cord is rapidly followed by a loss of this PGE<sub>2</sub> influence and the onset of air breathing. The administration of indomethacin to fetal sheep increases, whereas infusion of PGE suppresses, fetal breathing movements. This may be the explanation for the decrease in fetal breathing movements observed during human labor (associated with an increase in prostaglandin levels).

# FETAL LUNG MATURATION

---

The pulmonary alveoli are lined with a surface-active phospholipid-protein complex called pulmonary surfactant, which is synthesized in the type II pneumocyte of mature lungs. It is this surfactant that decreases surface tension, thereby facilitating lung expansion and preventing atelectasis. In full-term fetuses, surfactant is present at birth in sufficient amounts to permit adequate lung expansion and normal breathing. In premature fetuses, however, surfactant is present in lesser amounts, and, when insufficient, postnatal lung expansion and ventilation are frequently impaired, resulting in progressive atelectasis, the clinical syndrome of respiratory distress.

Phosphatidylcholine (lecithin) has been identified as the most active and most abundant lipid of the surfactant complex. The second most active and abundant material is phosphatidylglycerol (PG), which significantly enhances surfactant function. Both are present in only small concentrations until the last 5 weeks of pregnancy. Beginning at 20–22 weeks of pregnancy, a less stable and less active lecithin, palmitoyl-myristoyl lecithin, is formed. Hence, a premature infant does not always develop respiratory distress syndrome; however, in addition to being less active, synthesis of this lecithin is decreased by stress and acidosis, making the premature infant more susceptible to respiratory distress. At about the 35th week of gestation, there is a sudden surge of dipalmitoyl lecithin, the major surfactant lecithin, which is stable and very active. Because secretion by the fetal lungs contributes to the formation of amniotic fluid and the sphingomyelin concentration of amniotic fluid changes relatively little throughout pregnancy, assessment of the lecithin/sphingomyelin (L/S) ratio in amniotic fluid at approximately 34–36 weeks of pregnancy can determine the amount of dipalmitoyl lecithin available and thus the degree to which the lungs will adapt to newborn life.

Gluck and colleagues, in 1971, were the first to demonstrate that the L/S ratio correlates with pulmonary maturity of the fetal lung.<sup>461</sup> In normal development, sphingomyelin concentrations are greater than those of lecithin until about gestational week 26. Prior to 34 weeks, the L/S ratio is approximately 1:1. At 34–36 weeks, with the sudden increase in lecithin, the ratio rises acutely. In general, a ratio of 2.0 or greater indicates pulmonary maturity and that respiratory distress syndrome will not develop in the newborn.<sup>462</sup> Respiratory distress syndrome associated with a ratio greater than 2.0 usually follows a difficult delivery with a low 5-minute Apgar score, suggesting that severe acidosis can inhibit surfactant production. A ratio in the transitional range (1.0–1.9) indicates that respiratory distress syndrome may develop but that the fetal lung has entered the period of lecithin production, and a repeat amniocentesis in 1 or 2 weeks usually reveals a mature L/S ratio. The rise from low to high ratios can occur within 3–4 days.

An increase in the surfactant content of PG at 34–36 weeks marks the final maturation of the fetal lung. When the L/S ratio is greater than 2.0 and PG is present, the incidence of respiratory distress syndrome is virtually zero. The assessment of PG is especially helpful when the amniotic fluid is contaminated because the analysis is not affected by meconium, blood, or vaginal secretions. The L/S ratio has been replaced in many centers by a method that uses fluorescence polarization with a fluorescent probe that binds to surfactant. The fluorescent method is simple, automated, rapid, and less costly.

Abnormalities of pregnancy may affect the rate of maturation of the fetal lung, resulting either in an early mature L/S ratio or a delayed rise in the ratio. Accelerated maturation of the ratio is associated with hypertension, advanced diabetes, hemoglobinopathies, heroin addiction, and poor maternal nutrition. Delayed maturation is seen with diabetes (without hypertension) and Rh sensitization. In general, accelerated maturation is associated with reductions in uteroplacental blood flow (and presumably increased fetal stress). With vigorous and effective control of maternal diabetes, the risk of respiratory distress syndrome in the newborns is not significantly different from infants born to nondiabetics.

Since Graham Liggins observed survival of premature lambs following the administration of cortisol to the fetus,<sup>463</sup> it has become recognized that fetal cortisol is the principal requisite for surfactant biosynthesis. This is true despite the fact that no increase in fetal cortisol can be demonstrated to correlate with the increases in fetal lung maturation. For this reason, fetal lung maturation can be best viewed as the result of not only cortisol but also the synergistic action of prolactin, thyroxine, estrogens, prostaglandins, growth factors, and perhaps other yet unidentified agents.<sup>464</sup> Insulin directly inhibits surfactant protein expression in fetal lung tissue, which explains the increase in respiratory distress syndrome associated with hyperglycemia in pregnancy (although this effect can be overcome by the stress associated with advanced diabetes).<sup>465</sup>

Corticosteroid therapy of pregnant women threatened with preterm delivery reduces neonatal mortality, respiratory distress syndrome, and intraventricular hemorrhage.<sup>466</sup> In general, maximal benefit in terms of enhanced fetal pulmonic maturity has been demonstrated with glucocorticoid administration from 24 to 34 weeks of gestational age, with some benefit between 34 weeks and 36 6/7 weeks.<sup>466,467</sup> The optimal effect requires that 48 hours elapse after initiation of therapy although some benefit is achieved within hours after administration. The current recommendation in the United States is to administer two doses of betamethasone, 12 mg intramuscularly 24 hours apart, or four doses of dexamethasone, 6 mg intramuscularly every 12 hours for pregnant women between 24 0/7 weeks and 36 6/7 weeks of gestation who are at risk of preterm



delivery within 7 days.<sup>466,467</sup> Multiple weekly treatments or serial courses are no longer recommended, but a single repeat course of antenatal corticosteroids should be considered in women who are less than 34 0/7 weeks of gestation who are at risk of preterm delivery within 7 days and require consultation with a maternal-fetal medicine specialist. Although every case of respiratory distress syndrome and subsequent chronic lung disease cannot be prevented, a significant impact can be achieved on infant mortality and the incidence and severity of respiratory distress syndrome. Additional treatment with TRH was initially believed to be beneficial; however, clinical trials indicate that TRH does not further reduce the incidence of chronic lung disease in glucocorticoid-treated very low birth weight infants.<sup>468,469,470</sup>

# THE POSTPARTUM PERIOD

---

The immediate postpartum period is a time of rapid readjustment to the nonpregnant endocrine state. About 10–15% of women become clinically depressed during this time, and an endocrine mechanism has been suggested.<sup>471</sup> The clinician should always have a high index of suspicion for thyroid dysfunction because of the 5–10% incidence of postpartum thyroiditis in the 3–6 months after delivery. Because of the relative hypercortisolism in the last trimester of pregnancy, it has been suggested that persistent suppression of hypothalamic CRH secretion (and thus the pituitary-adrenal axis) in the postpartum period is a characteristic finding in women with postpartum depression and that this suppression also contributes to a greater vulnerability to autoimmune diseases, such as thyroiditis.<sup>472</sup>

# REFERENCES

1. **Csapo AL, Pulkkinen MO, Wiest WG**, Effects of luteectomy and progesterone replacement in early pregnant patients, *Am J Obstet Gynecol* 115:759, 1973.
2. **Beckers NG, Macklon NS, Eijkemans MJ, Ludwig M, Felberbaum RE, Diedrich K, Bustion S, Loumaye E, Fauser BC**, Nonsupplemented luteal phase characteristics after the administration of recombinant human chorionic gonadotropin, recombinant luteinizing hormone, or gonadotropin-releasing hormone (GnRH) agonist to induce final oocyte maturation in in vitro fertilization patients after ovarian stimulation with recombinant follicle-stimulating hormone and GnRH antagonist cotreatment, *J Clin Endocrinol Metab* 88(9):4186, 2003.
3. **van der Linden M, Buckingham K, Farquhar C, Kremer JA, Metwally M**, Luteal phase support for assisted reproduction cycles, *Cochrane Database Syst Rev* (10):CD009154, 2011.
4. **Schneider MA, Davies MC, Honour JW**, The timing of placental competence in pregnancy after oocyte donation, *Fertil Steril* 59:1059, 1993.
5. **Azuma K, Calderon I, Besanko M, Maclachlan V, Healy D**, Is the luteo-placental shift a myth? Analysis of low progesterone levels in successful ART pregnancies, *J Clin Endocrinol Metab* 77:195, 1993.
6. **Sultan KM, Davis OK, Liu H-C, Rosenwaks Z**, Viable term pregnancy despite "subluteal" serum progesterone levels in the first trimester, *Fertil Steril* 60:363, 1993.
7. **Mishell DR Jr, Thorneycroft IH, Nagata Y, Murata T, Nakamura RM**, Serum gonadotropin and steroid patterns in early human gestation, *Am J Obstet Gynecol* 117:631, 1973.
8. **Tulchinsky D, Hobel CJ**, Plasma human and chorionic gonadotropin, estrogen, estradiol, estriol, progesterone and 17 $\alpha$ -hydroxyprogesterone in human pregnancy, *Am J Obstet Gynecol* 117:884, 1973.
9. **Parker CR, Illingworth DR, Bissonnette J, Carr BR**, Endocrine changes during pregnancy in a patient with homozygous familial hypobetalipoproteinemia, *N Engl J Med* 314:557, 1986.
10. **Albrecht ED, Pepe GJ**, Placental steroid hormone biosynthesis in primate pregnancy, *Endocr Rev* 11:124, 1990.
11. **Begum-Hasan J, Murphy BEP**, In vitro stimulation of placental progesterone production by 19-nortestosterone and C19 steroids in early human pregnancy, *J Clin Endocrinol Metab* 75:838, 1992.
12. **Bhattacharyya S, Chaudhary J, Das C**, Antibodies to hCG inhibit progesterone production from human syncytiotrophoblast cells, *Placenta* 13:135, 1992.
13. **Pepe GJ, Albrecht ED**, Actions of placental and fetal adrenal steroid hormones in primate pregnancy, *Endocr Rev* 16:608, 1995.
14. **Grimes RW, Pepe GJ, Albrecht ED**, Regulation of human placental trophoblast low-density lipoprotein uptake in vitro by estrogen, *J Clin Endocrinol Metab* 81:2675, 1996.
15. **Carr BR, Simpson ER**, Cholesterol synthesis by human fetal hepatocytes: effect of lipoproteins, *Am J Obstet Gynecol* 150:551, 1984.
16. **Mitchell BF, Challis JRG, Lukash L**, Progesterone synthesis by human amnion, chorion, and decidua at term, *Am J Obstet Gynecol* 157:349, 1987.
17. **Tulchinsky D, Simmer HH**, Sources of plasma 17 $\alpha$ -hydroxyprogesterone in human pregnancy, *J Clin Endocrinol Metab* 35:799, 1972.
18. **Parker CR, Everett RB, Quirk JG, Whalley PJ, Gant NF**, Hormone production during pregnancy in the primigravid patient: I. Plasma levels of progesterone and 5-pregnane-3,20-dione throughout pregnancy of normal women and women who developed pregnancy-induced hypertension, *Am J Obstet Gynecol* 135:778, 1979.
19. **Parker CR, Everett RB, Whalley PJ, Quirk JG, Gant NF, MacDonald PC**, Hormone production during pregnancy in the primigravid patient: II. Plasma levels of deoxycorticosterone throughout pregnancy of normal women and women who developed pregnancy-induced hypertension, *Am J Obstet Gynecol* 138:626, 1980.
20. **Rothchild I**, Role of progesterone in initiating and maintaining pregnancy, In: Bardin CW, Milgrom E, Mauvais-Jarvis P, eds. *Progesterone and Progestins*, Raven Press, New York, 1983, p. 219.

21. **Carr BR, Simpson ER**, Lipoprotein utilization and cholesterol synthesis by the human fetal adrenal gland, *Endocr Rev* 2:306, 1981.
22. **Partsch C-J, Sippell WG, Mackenzie IZ, Aynsley-Green A**, The steroid hormonal milieu of the undisturbed human fetus and mother at 16–20 weeks gestation, *J Clin Endocrinol Metab* 73:969, 1991.
23. **Siiteri PK, MacDonald PC**, The utilization of circulating dehydroisoandrosterone sulfate for estrogen synthesis during human pregnancy, *Steroids* 2:713, 1963.
24. **Siiteri PK, MacDonald PC**, Placental estrogen biosynthesis during human pregnancy, *J Clin Endocrinol Metab* 26:751, 1966.
25. **Voutilainen R, Ilvesmaki V, Miettinen PJ**, Low expression of 3 $\beta$ -hydroxy-5-ene steroid dehydrogenase gene in human fetal adrenals in vivo; adrenocorticotropin and protein kinase C-dependent regulation in adrenocortical cultures, *J Clin Endocrinol Metab* 72:761, 1991.
26. **Madden JD, Gant NF, MacDonald PC**, Study of the kinetics of conversion of maternal plasma dehydroisoandrosterone sulfate to 16-hydroxydehydroisoandrosterone sulfate, estradiol, and estriol, *Am J Obstet Gynecol* 132:392, 1978.
27. **Buster JE, Abraham GE**, The applications of steroid hormone radioimmunoassays to clinical obstetrics, *Obstet Gynecol* 46:489, 1975.
28. **Buster JE, Sakakini Jr J, Killam AP, Scragg WH**, Serum unconjugated estriol levels in the third trimester and their relationship to gestational age, *Am J Obstet Gynecol* 125:672, 1975.
29. **Katzenellenbogen BS**, Biology and receptor interactions of estriol and estriol derivatives in vitro and in vivo, *J Steroid Biochem* 20:1033, 1984.
30. **Longo LD**, Maternal blood volume and cardiac output during pregnancy: an hypothesis of endocrinologic control, *Am J Physiol* 245:R720, 1983.
31. **Simpson ER, Mahendroo MS, Means GD, Kilgore MW, Hinshelwood MM, Graham-Lorence S, Amarneh B, Ito Y, Fisher CR, Michael MD, Mendelson CR, Bulun SE**, Aromatase cytochrome P450, the enzyme responsible for estrogen biosynthesis, *Endocr Rev* 15:342, 1994.
32. **Morishima A, Grumbach MM, Simpson ER, Fisher C, Qin K**, Aromatase deficiency in male and female siblings caused by a novel mutation and the physiological role of estrogens, *J Clin Endocrinol Metab* 80:3689, 1995.
33. **MacDonald PC, Siiteri PK**, Origin of estrogen in women pregnant with an anencephalic fetus, *J Clin Invest* 44:465, 1965.
34. **Mesiano S, Jaffe RB**, Developmental and functional biology of the primate fetal adrenal cortex, *Endocr Rev* 18:378, 1997.
35. **Parker CR Jr, Leveno K, Car BR, Hauth J, MacDonald PC**, Umbilical cord plasma levels of dehydroepiandrosterone sulfate during human gestation, *J Clin Endocrinol Metab* 54:1216, 1982.
36. **Rehman KS, Carr BR, Rainey WE**, Profiling the steroidogenic pathway in human fetal and adult adrenals, *J Soc Gynecol Investig* 10:372, 2003.
37. **Winters AJ, Oliver C, Colston C, MacDonald PC, Porter JC**, Plasma ACTH levels in the human fetus and neonate as related to age and parturition, *J Clin Endocrinol Metab* 39:2690, 1974.
38. **Walsh SW, Norman RL, Novy MJ**, In utero regulation of rhesus monkey fetal adrenals: effects of dexamethasone, adrenocorticotropin, thyrotropin-releasing hormone, prolactin, human chorionic gonadotropin, and  $\alpha$ -melanocyte-stimulating hormone on fetal and maternal plasma steroids, *Endocrinology* 104:1805, 1979.
39. **Abu-Hakima M, Branchaud CL, Goodyer CG, Murphy BEP**, The effects of human chorionic gonadotropin on growth and steroidogenesis of the human fetal adrenal gland in vitro, *Am J Obstet Gynecol* 156:681, 1987.
40. **del Pozo E, Bigazzi M, Calaf J**, Induced human gestational hypoprolactinemia: lack of action on fetal adrenal androgen synthesis, *J Clin Endocrinol Metab* 51:936, 1980.
41. **Walker ML, Pepe GJ, Albrecht ED**, Regulation of baboon fetal adrenal androgen formation by pituitary peptides at mid- and late gestation, *Endocrinology* 122:546, 1988.
42. **McNulty WP, Novy MJ, Walsh SW**, Fetal and postnatal development of the adrenal glands in *Macaca mulatta*, *Biol Reprod* 25:1079, 1981.

43. **Pepe GJ, Albrecht ED**, Regulation of the primate fetal adrenal cortex, *Endocr Rev* 11:151, 1990.
44. **Mason JI, Rainey WE**, Steroidogenesis in the human fetal adrenal: a role for cholesterol synthesized de novo, *J Clin Endocrinol Metab* 64:140, 1987.
45. **Mesiano S, Fujimoto VY, Nelson LR, Lee JY, Voytek CC, Jaffe RB**, Localization and regulation of corticotropin receptor expression in the midgestation human fetal adrenal cortex: implications for in utero homeostasis, *J Clin Endocrinol Metab* 81:340, 1996.
46. **Brown RW, Chapman KE, Kotelevtsev Y, Yau JLW, Lindsay RS, Brett L, Leckie C, Murad P, Lyons V, Mullins JJ, Edwards CRW, Seckl JR**, Cloning and production of antisera to human placental 11 $\beta$ -hydroxysteroid dehydrogenase type 2, *Biochem J* 313:1007, 1996.
47. **Baggia S, Albrecht ED, Pepe GJ**, Regulation of 11 beta-hydroxysteroid dehydrogenase activity in the baboon placenta by estrogen, *Endocrinology* 126:2742, 1990.
48. **Pepe GJ, Davies WA, Albrecht ED**, Activation of the baboon fetal pituitary-adrenocortical axis at midgestation by estrogen: enhancement of fetal pituitary proopiomelanocortin messenger ribonucleic acid expression, *Endocrinology* 135:2581, 1994.
49. **Edwards CR, Benediktsson R, Lindsay RS, Seckl JR**, Dysfunction of placental glucocorticoid barrier: link between fetal environment and adult hypertension? *Lancet* 341:355, 1993.
50. **Fall CHD, Osmond C, Barker DJP, Clark PMS, Hales CN, Stirling Y, Meade TW**, Fetal and infant growth and cardiovascular risk factors in women, *Br Med J* 310:428, 1995.
51. **Dy J, Guan H, Sampath-Kumar R, Richardson BS, Yang K**, Placental 11 $\beta$ -hydroxysteroid dehydrogenase type 2 is reduced in pregnancies complicated with idiopathic intrauterine growth restriction: evidence that this is associated with an attenuated ratio of cortisone to cortisol in the umbilical artery, *Placenta* 29:193, 2008.
52. **Schoof E, Girstl M, Frobenius W, Kirschbaum M, Dörr HG, Rascher W, Dötsch J**, Decreased gene expression of 11beta-hydroxysteroid dehydrogenase type 2 and 15-hydroxyprostaglandin dehydrogenase in human placenta of patients with preeclampsia, *J Clin Endocrinol Metab* 86:1313, 2001.
53. **Yang K, Julan L, Rubio F, Sharma A, guan H**, Cadmium reduces 11beta-hydroxysteroid dehydrogenase type 2 activity and expression in human placental trophoblast cells, *Am J Physiol Endocrinol Metab* 290:E135, 2006.
54. **Sato K, Chisaka H, Okamura, K, Challis JR**, Effect of the interaction between lipoxygenase pathway and progesterone on the regulation of hydroxysteroid 11-beta dehydrogenase 2 in cultured human term placental trophoblasts, *Biol Reprod* 78:514, 2008.
55. **Karalis K, Goodwin G, Majzoub JA**, Cortisol blockade of progesterone: a possible molecular mechanism involved in the initiation of human labor, *Nat Med* 2:556, 1996.
56. **Smith R, Mesiano S, Chan E-C, Brown S, Jaffe RB**, Corticotropin-releasing hormone directly and preferentially stimulates dehydroepiandrosterone sulfate secretion by human fetal adrenal cortical cells, *J Clin Endocrinol Metab* 83:2916, 1998.
57. **Sirianni R, Mayhew BA, Carr BR, Parker CR Jr, Rainey WE**, Corticotropin-releasing hormone (CRH) and urocortin act through type 1 CRH receptors to stimulate dehydroepiandrosterone sulfate production in human fetal adrenal cells, *J Clin Endocrinol Metab* 90:5393, 2005.
58. **Rehman KS, Sirianni R, Parker CR Jr, Rainey WE, Carr BR**, The regulation of adrenocorticotropic hormone receptor by corticotropin-releasing hormone in human fetal adrenal definitive/transitional zone cells, *Reprod Sci* 14:578, 2007.
59. **Voutilainen R, Eramaa M, Ritvos O**, Hormonally regulated inhibin gene expression in human fetal and adult adrenals, *J Clin Endocrinol Metab* 73:1026, 1991.
60. **Spencer SJ, Rabinovici J, Mesiano S, Goldsmith PC, Jaffe RB**, Activin and inhibin in the human adrenal gland. Regulation and differential effects in fetal and adult cells, *J Clin Invest* 90:1420, 1992.
61. **Mesiano S, Katz SL, Lee JY, Jaffe RB**, Insulin-like growth factors augment steroid production and expression of steroidogenic enzymes in human fetal adrenal cortical cells: implications for adrenal androgen regulation, *J Clin Endocrinol Metab* 82:1390, 1997.
62. **D'Ercole AJ**, Somatomedins/insulin-like growth factors and fetal growth, *J Dev Physiol* 9:481, 1987.
63. **Mesiano S, Mellon SH, Jaffe RB**, Mitogenic action, regulation, and localization of insulin-like growth factors

- in the human fetal adrenal gland, *J Clin Endocrinol Metab* 76:968, 1993.
64. **Luo X, Ikeda Y, Parker KL**, A cell-specific nuclear receptor is essential for adrenal and gonadal development and sexual differentiation, *Cell* 77:481, 1994.
  65. **Parker KL, Schimmer BP**, Steroidogenic factor 1: a key determinant of endocrine development and function, *Endocr Rev* 18:361, 1997.
  66. **Burris TP, Guo W, McCabe ER**, The gene responsible for adrenal hypoplasia congenita, DAX-1, encodes a nuclear hormone receptor that defines a new class within the superfamily, *Recent Prog Horm Res* 51:241, 1996.
  67. **Fujieda K, Faiman C, Reyes FI, Winter JSD**, The control of steroidogenesis by human fetal adrenal cells in tissue culture: I. Responses to adrenocorticotropin, *J Clin Endocrinol Metab* 53:34, 1981.
  68. **Fujieda K, Faiman C, Reyes FI, Thliveris J, Winter JSD**, The control of steroidogenesis by human fetal adrenal cells in tissue culture: II. Comparison of morphology and steroid production in cells of the fetal and definitive zones, *J Clin Endocrinol Metab* 53:401, 1981.
  69. **Fujieda K, Faiman C, Reyes FI, Winter JSD**, The control of steroidogenesis by human fetal adrenal cells in tissue culture: III. The effects of various hormonal peptides, *J Clin Endocrinol Metab* 53:690, 1981.
  70. **Mesiano S, Jaffe RB**, Interaction of insulin-like growth factor-II and estradiol directs steroidogenesis in the human fetal adrenal toward dehydroepiandrosterone sulfate production, *J Clin Endocrinol Metab* 77:754, 1993.
  71. **Fujieda K, Faiman C, Reyes FI, Winter JSD**, The control of steroidogenesis by human fetal adrenal cells in tissue culture: IV. The effects of exposure to placental steroids, *J Clin Endocrinol Metab* 54:89, 1982.
  72. **Byrne GC, Perry YS, Winter JSD**, Steroid inhibitory effects upon human adrenal 3 $\beta$ -hydroxysteroid dehydrogenase activity, *J Clin Endocrinol Metab* 62:413, 1986.
  73. **Gell JS, Oh J, Rainey WE, Carr BR**, Effect of estradiol on DHEAS production in the human adrenocortical cell line, H295R, *J Soc Gynecol Investig* 5:144, 1998.
  74. **Rainey WE, Carr BR, Sasano H, Suzuki T, Mason JI**, Dissecting human adrenal androgen production, *Trends Endocrinol Metab* 13:234, 2002.
  75. **Ducsay CA, Hess DL, McClellan MC, Novy MJ**, Endocrine and morphological maturation of the fetal and neonatal adrenal cortex in baboons, *J Clin Endocrinol Metab* 73:385, 1991.
  76. **Albrecht ED, Pepe GJ**, Central integrative role of oestrogen in modulating the communication between the placenta and fetus that results in primate fetal-placental development, *Placenta* 20:129, 1999.
  77. **Albrecht ED, Aberdeen GW, Pepe GJ**, Estrogen elicits cortical zone-specific effects on development of the primate fetal adrenal gland, *Endocrinology* 146:1737, 2005.
  78. **Dumitrescu A, Aberdeen GW, Pepe GJ, Albrecht ED**, Developmental expression of cell cycle regulators in the baboon fetal adrenal gland, *J Endocrinol* 192:237, 2007.
  79. **Fritz MA, Stanczyk FZ, Novy MJ**, Relationship of uteroplacental blood flow to the placental clearance of maternal dehydroepiandrosterone through estradiol formation in the pregnant baboon, *J Clin Endocrinol Metab* 61:1023, 1985.
  80. **Fritz MA, Stanczyk FZ, Novy MJ**, Maternal estradiol response to alterations in uteroplacental blood flow, *Am J Obstet Gynecol* 155:1317, 1986.
  81. **Shepherd RW, Stanczyk FZ, Bethea CL, Novy MJ**, Fetal and maternal endocrine responses to reduced uteroplacental blood flow, *J Clin Endocrinol Metab* 75:301, 1992.
  82. **Distler W, Gabbe SG, Freeman RK, Mestman JH, Goebelsmann U**, Estriol in pregnancy: V. Unconjugated and total plasma estriol in the management of pregnant diabetic patients, *Am J Obstet Gynecol* 130:424, 1978.
  83. **Coelingh Bennink F, Holinka CF, Visser M, Coelingh Bennink HJT**, Maternal and fetal estetrol levels during pregnancy, *Climacteric* 11(Suppl 1):69, 2008.
  84. **Coelingh Bennink HJT, Holinka CF, Diczfalusy E**, Estetrol review: profile and potential clinical applications, *Climacteric* 11(Suppl 1):47, 2008.
  85. **Bradshaw KD, Carr BR**, Placental sulfatase deficiency: maternal and fetal expression of steroid sulfatase deficiency and X-linked ichthyosis, *Obstet Gynecol Surv* 41:401, 1986.
  86. **Rizk DEE, Johansen KA**, Maternal steroid sulfatase deficiency—cause of high-risk pregnancy? *Am J*

Obstet Gynecol 171:566, 1994.

87. **Bradley LA, Canick JA, Palomaki GE, Haddow JE**, Undetectable maternal serum unconjugated estriol levels in the second trimester: risk of perinatal complications associated with placental sulfatase deficiency, *Am J Obstet Gynecol* 176:531, 1997.
88. **Thauvin-Robinet C, Lambert D, Vaillant G, Caillier P, Donzel A, Cusin V, Huet F, Teyssier JR, Mugneret F, Faivre L**, X-linked recessive ichthyosis in a girl: strategy for identifying the causal mechanism, *Br J Dermatol* 152:191, 2005.
89. **Mevorah B, Frenk E, Müller CR, Ropers HH**, X-linked recessive ichthyosis in three sisters: evidence for homozygosity, *Br J Dermatol* 105:711, 1981.
90. **Kent L, Emerton J, Bhadravathi V, Weisblatt E, Pasco G, Willatt LR, McMahon R, Yates JRW**, X-linked ichthyosis (steroid sulfatase deficiency) is associated with increased risk of attention deficit hyperactivity disorder, autism, and social communication deficits, *J Med Genet* 45:519, 2008.
91. **Shi QJ, Lei ZM, Rao CV, Lin J**, Novel role of human chorionic gonadotropin in differentiation of human cytotrophoblasts, *Endocrinology* 132:1387, 1993.
92. **Petraglia F, Florio P, Nappi C, Genazzani AR**, Peptide signaling in human placenta and membranes: autocrine, paracrine, and endocrine mechanisms, *Endocr Rev* 17:156, 1996.
93. **Siler-Khodr TM, Khodr GS**, Production and activity of placental releasing hormones, In: Novy MJ, Resko JA, eds. *Fetal Endocrinology*, Academic Press, New York, 1981, p. 183.
94. **Siler-Khodr TM, Kuehl TJ, Vickery BH**, Effects of a gonadotropin-releasing antagonist on hormone levels in the pregnant baboon and on fetal outcome, *Fertil Steril* 41:448, 1984.
95. **Siler-Khodr TM, Khodr GS, Harper MJK, Rhode J, Vickery BH, Nestor JJ Jr**, Differential inhibition of human placental prostaglandin release in vitro by a GnRH antagonist, *Prostaglandins* 31:1003, 1986.
96. **Belisle S, Guevin J-F, Bellabarba D, Lehoux J-G**, Luteinizing hormone-releasing hormone binds to enriched placental membranes and stimulates in vitro the synthesis of bioactive human chorionic gonadotropin, *J Clin Endocrinol Metab* 59:119, 1984.
97. **Siler-Khodr TM, Khodr GS, Rhode J, Vickery BH, Nestor JJ Jr**, Gestational age-related inhibition of placental hCG, alpha hCG and steroid hormone release in vitro by a GnRH antagonist, *Placenta* 8:1, 1987.
98. **Miyake A, Sakumoto T, Anono T, Kawamura Y, Maeda T, Kurachi K**, Changes in luteinizing hormone-releasing hormone in human placenta throughout pregnancy, *Obstet Gynecol* 60:444, 1982.
99. **Kelly AC, Rodgers A, Dong K-W, Barrezueta NX, Blum M, Roberts JL**, Gonadotropin-releasing hormone and chorionic gonadotropin gene expression in human placental development, *DNA Cell Biol* 10:411, 1991.
100. **Hay DL**, Placental histology and the production of human choriogonadotrophin and its subunits in pregnancy, *Br J Obstet Gynaecol* 95:1268, 1988.
101. **Barnea ER, Kaplan M**, Spontaneous, gonadotropin-releasing hormone-induced, and progesterone-inhibited pulsatile secretion of human chorionic gonadotropin in the first trimester placenta in vitro, *J Clin Endocrinol Metab* 69:215, 1989.
102. **Chou CS, Gilks CB, Auersperg N, Leung PC**, Cellular localization of gonadotropin-releasing hormone (GnRH) I and GnRH II in first-trimester human placenta and decidua, *J Clin Endocrinol Metab* 89:1459, 2006.
103. **Xing Y, Nakamura Y, Rainey WE**, G protein-coupled receptor expression in the adult, fetal adrenal glands, *Mol Cell Endocrinol* 300:43, 2008. doi:10.1016/j.mce.2008.10.036.
104. **Iwashita M, Evans MI, Catt KJ**, Characterization of a gonadotropin-releasing hormone receptor site in term placenta and chorionic villi, *J Clin Endocrinol Metab* 62:127, 1986.
105. **Bramley TA, Mcphie CA, Menzies GS**, Human placental gonadotropin-releasing hormone (GnRH) binding sites. I. Characterization, properties and ligand specificity, *Placenta* 13:555, 1992.
106. **Lin L-S, Roberts VJ, Yen S**, Expression of human gonadotropin-releasing hormone receptor gene in the placenta and its functional relationship to human chorionic gonadotropin secretion, *J Clin Endocrinol Metab* 80:580, 1995.
107. **Jones SA, Brooks AN, Challis JRG**, Steroids modulate corticotropin-releasing hormone production in human fetal membranes and placenta, *J Clin Endocrinol Metab* 68:825, 1989.

108. **Challis JRG, Matthews SG, Van Meir C, Ramirez MM**, Current topic: the placental corticotrophin-releasing hormone-adrenocorticotrophin axis, *Placenta* 16:481, 1995.
109. **Petraglia F, Florio P, Gallo R, Simoncini T, Saviozzi M, Di Blasio AM, Vaughan J, Vale W**, Human placenta and fetal membranes express human urocortin mRNA and peptide, *J Clin Endocrinol Metab* 81:3807, 1996.
110. **Li W, Challis JR**, Corticotrophin-releasing hormone and urocortin induce secretion of matrix metalloproteinase-9 (MMP-9) without change in tissue inhibitors of MMP-1 by cultured cells from human placenta and fetal membranes, *J Clin Endocrinol Metab* 90:6569, 2005.
111. **Iavazzo C, Baka S, Malamitsi-Puchner A**, The role of urocortin in gynecological and obstetrical conditions, *Arch Gynecol Obstet* 279:613, 2009.
112. **Bajoria R, Babawale M**, Ontogeny of endogenous secretion of immunoreactive-thyrotropin releasing hormone by the human placenta, *J Clin Endocrinol Metab* 83:4148, 1998.
113. **Reis FM, Florio P, Cobellis L, Luisi S, Severi FM, Bocchi C, Picciolini E, Centini G, Petraglia F**, Human placenta as a source of neuroendocrine factors, *Biol Neonate* 79(3–4):150, 2001.
114. **Gaylinn BD**, Molecular and cell biology of the growth hormone-releasing hormone receptor, *Growth Horm IGF Res* 9(Suppl A):37, 1999.
115. **Ren S-G, Braunstein GD**, Human chorionic gonadotropin, *Semin Reprod Endocrinol* 10:95, 1992.
116. **Lapthorn AJ, Harris DC, Littlejohn A, Lustbader JW, Canfield RE, Machin KJ, Mogan FJ, Isaacs NW**, Crystal structure of human chorionic gonadotropin, *Nature* 369:455, 1994.
117. **Gharib SD, Wierman ME, Shupnik MA, Chin WW**, Molecular biology of the pituitary gonadotropins, *Endocr Rev* 11:177, 1990.
118. **Albanese C, Colin IM, Crowley WF, Ito M, Pestell RG, Weiss J, Jameson JL**, The gonadotropin genes: evolution of distinct mechanisms for hormonal control, *Recent Prog Horm Res* 51:23, 1996.
119. **Jameson JL, Hollenberg AN**, Regulation of chorionic gonadotropin gene expression, *Endocr Rev* 14:203, 1993.
120. **Maston GA, Ruvolo M**, Chorionic gonadotropin has a recent origin within primates and an evolutionary history of selection, *Mol Biol Evol* 19:320, 2002.
121. **Henke A, Gromoll J**, New insights into the evolution of chorionic gonadotrophin, *Mol Cell Endocrinol* 291:11, 2008.
122. **Layman LC, Edwards JL, Osborne WE, Peak DB, Gallup DG, Tho SPT, Reindollar RH, Roach DJ, McDonough PG, Lanclos KD**, Human chorionic gonadotrophin- $\beta$  gene sequences in women with disorders of HCG production, *Mol Hum Reprod* 3:315, 1997.
123. **Tan L, Rousseau P**, The chemical identity of the immunoreactive LHRH-like peptide biosynthesized in the placenta, *Biochem Biophys Res Commun* 109:1061, 1982.
124. **Merz WE, Dorner M**, Studies on structure-function relationships of human choriogonadotropins with C-terminally shortened alpha subunits. I. Receptor binding and immunologic properties, *Biochim Biophys Acta* 844:62, 1985.
125. **Siler-Khodr TM, Khodr GS, Valenzuela G, Rhode J**, Gonadotropin-releasing hormone effects on placental hormones during gestation. II. Progesterone, estrone, estradiol and estriol, *Biol Reprod* 34:255, 1986.
126. **Steele GL, Currie WD, Leung E, Ho Yuen B, Leung PCK**, Rapid stimulation of human chorionic gonadotropin secretion by interleukin-1 from perfused first trimester trophoblast, *J Clin Endocrinol Metab* 75:783, 1992.
127. **Barnea ER, Ashkenazy R, Tal Y, Kol S, Sarne Y**, Effect of  $\beta$ -endorphin on human chorionic gonadotrophin secretion by placental explants, *Hum Reprod* 6:1327, 1991.
128. **Petraglia F, Vaughn J, Vale W**, Inhibin and activin modulate the release of gonadotropin-releasing hormone, human chorionic gonadotropin, and progesterone from cultured placental cells, *Proc Natl Acad Sci U S A* 86:5114, 1989.
129. **Petraglia F, Vaughan J, Vale W**, Steroid hormones modulate the release of immunoreactive gonadotropin-releasing hormone from cultured human placental cells, *J Clin Endocrinol Metab* 70:1173, 1990.
130. **Qu J, Brulet C, Thomas K**, Effect of epidermal growth factor on inhibin secretion in human placental cell



- culture, *Endocrinology* 131:2173, 1992.
131. **Qu J, Thomas K**, Prostaglandins stimulate the secretion of inhibin from human placental cells, *J Clin Endocrinol Metab* 77:556, 1993.
  132. **Bonduelle M, Dodd R, Liebaers I, Steirteghem A, Williamson R, Akhurst R**, Chorionic gonadotropin- $\beta$  mRNA, a trophoblast marker, is expressed in human 8-cell embryos derived from tripronucleate zygotes, *Hum Reprod* 3:909, 1988.
  133. **Rabinovici J, Jaffe RB**, Development and regulation of growth and differentiated function of human and subhuman primate fetal gonads, *Endocr Rev* 11:532, 1990.
  134. **O'Shaughnessy PJ, Fleming LM, Jackson G, Hochgeschwender U, Reed P, Baker PJ**, Adrenocorticotrophic hormone directly stimulates testosterone production by the fetal and neonatal mouse testis, *Endocrinology* 144:3279, 2003.
  135. **Rothman PA, Chao VA, Taylor MR, Kuhn RW, Jaffe RB, Taylor RN**, Extraplacental human fetal tissues express mRNA transcripts encoding the human chorionic gonadotropin- $\beta$  subunit protein, *Mol Reprod Dev* 33:1, 1992.
  136. **Yang M, Lei ZM, Rao C**, The central role of human chorionic gonadotropin in the formation of human placental syncytium, *Endocrinology* 144:1108, 2003.
  137. **Hoshina M, Boothby M, Boime I**, Cytological localization of chorionic gonadotropin  $\alpha$  and placental lactogen mRNA during development of human placenta, *J Cell Biol* 93:190, 1982.
  138. **Nakajima ST, McAuliffe T, Gibson M**, The 24-hour pattern of the levels of serum progesterone and immunoreactive human chorionic gonadotropin in normal early pregnancy, *J Clin Endocrinol Metab* 71:345, 1990.
  139. **Cole LA, Kardan A, Andrade-Gordon P, Gawinowicz MA, Morris JC, Bergert ER, O'Connor J, Birken S**, The heterogeneity of hCG: III. The occurrence, biological and immunological activities of nicked hCG, *Endocrinology* 129:1559, 1991.
  140. **Wide L, Lee J-Y, Rasmussen C**, A change in the isoforms of human chorionic gonadotropin occurs around the 13th week of gestation, *J Clin Endocrinol Metab* 78:1419, 1994.
  141. **Maruo T, Matsuo H, Ohtani T, Hoshina M, Mochizuchi M**, Differential modulation of chorionic gonadotropin (CG) subunit messenger ribonucleic acid level and CG secretion by progesterone in normal placenta and choriocarcinoma cultured in vitro, *Endocrinology* 119:858, 1986.
  142. **Lepage N, Chitayat D, Kingdom J, Huang T**, Association between second-trimester isolated high maternal serum human chorionic gonadotropin levels and obstetric complications in singleton and twin pregnancies, *Am J Obstet Gynecol* 188:1354, 2003.
  143. **Schlaerth JB, Morrow CP, Kletzky OA, Nalick RH, D'Ablaing GA**, Prognostic characteristics of serum human chorionic gonadotropin titer regression following molar pregnancy, *Obstet Gynecol* 58:478, 1981.
  144. **Yedema KA, Verheijen RH, Kenemans P, Schijf CP, Borm GF, Segers MJ, Thomas CM**, Identification of patients with persistent trophoblastic disease by means of a normal human chorionic gonadotropin regression curve, *Am J Obstet Gynecol* 168:787, 1993.
  145. **Elliott MM, Kardana A, Lustbader JW, Cole LA**, Carbohydrate and peptide structure of the alpha- and beta-subunits of human chorionic gonadotropin from normal and aberrant pregnancy and choriocarcinoma, *Endocrine* 7:15, 1997.
  146. **Cole LA**, Hyperglycosylated hCG, *Placenta* 28:977, 2007.
  147. **Kovalevskaya G, Kakuma T, Schlatterer J, O'Connor JF**, Hyperglycosylated HCG expression in pregnancy: cellular origin and clinical applications, *Mol Cell Endocrinol* 260:237, 2007.
  148. **Palomaki GE, Neveux LM, Haddow JE, Wyatt P**, Hyperglycosylated-hCG (H-hCG) and Down syndrome screening in the first and second trimesters of pregnancy, *Prenat Diagn* 27:808, 2007.
  149. **de Medeiros SF, Norman RJ**, Human choriogonadotrophin protein core and sugar branches heterogeneity: basic and clinical insights, *Hum Reprod Update* 15:69, 2009.
  150. **Sasaki Y, Ladner DG, Cole LA**, Hyperglycosylated human chorionic gonadotropin and the source of pregnancy failures, *Fertil Steril* 89:1781, 2008.
  151. **Odell WD, Griffin J**, Pulsatile secretion of human chorionic gonadotropin in normal adults, *N Engl J Med*

317:1688, 1987.

152. **Odell WD, Griffin J**, Pulsatile secretion of chorionic gonadotropin during the normal menstrual cycle, *J Clin Endocrinol Metab* 69:528, 1989.
153. **Birken S, Maydelman Y, Gawinowicz MA, Pound A, Liu Y, Hartree AS**, Isolation and characterization of human pituitary chorionic gonadotropin, *Endocrinology* 137:1402, 1996.
154. **Patton PE, Hess DL, Cook DM, Loriaux DL, Braunstein GD**, Human chorionic gonadotropin production by the pituitary gland in a premenopausal women, *Am J Obstet Gynecol* 178:1138, 1998.
155. **Braunstein GD**, False-positive serum human chorionic gonadotropin results: causes, characteristics, and recognition, *Am J Obstet Gynecol* 187:217, 2002.
156. **Knight AK, Bingemann T, Cole L, Cunningham-Rundles C**, Frequent false positive beta human chorionic gonadotropin tests in immunoglobulin A deficiency, *Clin Exp Immunol* 141(2):333, 2005.
157. **Walker WH, Fitzpatrick SL, Barrera-Saldana HA, Resendes-Perez D, Saunders GF**, The human placental lactogen genes: structure, function, evolution and transcriptional regulation, *Endocr Rev* 12:316, 1991.
158. **Alsat E, Guibourdenche J, Luton D, Franckenne F, Evain-Brion D**, Human placental growth hormone, *Am J Obstet Gynecol* 177:1526, 1997.
159. **Kirwan JP, Hauguel-de Mouzon S, Leqercq J, Challier J-C, Huston-Presley L, Friedman JE, Kalhan SC, Catalano PM**, TNF- $\alpha$  is a predictor of insulin resistance in human pregnancy, *Diabetes* 51:2207, 2002.
160. **Fuglsang J, Moller N, Ledet T, Ovesen P**, Effects of glucose, glycerol, 3-hydroxybutyrate, insulin and leptin on placental growth hormone secretion in placental explants, *Horm Metab Res* 40:189, 2008.
161. **Grumbach MM, Kaplan SL, Vinik A, HCS**, In: Berson SA, Yalow RS, eds. *Peptide Hormones*, Vol. 2B, North-Holland, Amsterdam, 1973, p. 797.
162. **Spellacy WN, Buhi WC, Schram JC, Birk SA, McCreary SA**, Control of human chorionic somatomammotropin levels during pregnancy, *Obstet Gynecol* 37:567, 1971.
163. **Felig P, Lynch V**, Starvation in human pregnancy: hypoglycemia, hypoinsulinemia, and hyperketonemia, *Science* 170:990, 1970.
164. **Felig P**, Maternal and fetal fluid homeostasis in human pregnancy, *Am J Clin Nutr* 26:998, 1973.
165. **Felig P, Kim YJ, Lynch V, Hendler R**, Amino acid metabolism during starvation in human pregnancy, *J Clin Invest* 51:1195, 1972.
166. **Kim YJ, Felig P**, Plasma chorionic somatomammotropin levels during starvation in mid-pregnancy, *J Clin Endocrinol Metab* 32:864, 1971.
167. **Handwerker S**, Clinical counterpoint: the physiology of placental lactogen in human pregnancy, *Endocr Rev* 12:329, 1991.
168. **Barker DJP, Martyn CN, Osmond C, Hales CN, Fall CHD**, Growth in utero and serum cholesterol concentrations in adult life, *Br Med J* 307:1524, 1993.
169. **Gluckman PD, Hanson MA, Cooper C, Thornburg KL**, Effect of in utero and early-life conditions on adult health and disease, *N Engl J Med* 359:61, 2008.
170. **Desoye G, Schweditsch MO, Pfeiffer KP, Zechner R, Kostner GM**, Correlation of hormones with lipid and lipoprotein levels during normal pregnancy and postpartum, *J Clin Endocrinol Metab* 64:704, 1987.
171. **Kalkhoff RK**, Impact of maternal fuels and nutritional state on fetal growth, *Diabetes* 40(Suppl 2):61, 1991.
172. **Barker DJP, Hales CN, Fall CHD, Osmond C, Phipps K, Clark PMS**, Type 2 non-insulin-dependent-diabetes mellitus, hypertension and hyperlipidaemia (syndrome X): relation to reduced fetal growth, *Diabetologia* 36:620, 1993.
173. **Nielsen PV, Pedersen H, Kampmann E**, Absence of human placental lactogen in an otherwise uneventful pregnancy, *Am J Obstet Gynecol* 135:322, 1979.
174. **Sideri M, de Virgiliis G, Guidobono F, Borgese N, Sereni LP, Nicolini U, Remotti G**, Immunologically undetectable human placental lactogen in a normal pregnancy. Case report, *Br J Obstet Gynaecol* 90:771, 1983.
175. **Dawood MY, Teoh ES**, Serum human chorionic somatomammotropin in unaborted hydatidiform mole, *Obstet Gynecol* 47:183, 1976.
176. **Chiniwala NU, Woolf PD, Bruno CP, Kaur S, Spector H, Yacono K**, Thyroid storm caused by a partial hydatidiform mole, *Thyroid* 18:479, 2008.

177. **Pekonen F, Althan H, Stenman U, Ylikorkala O**, Human chorionic gonadotropin (hCG) and thyroid function in early human pregnancy: circadian variation and evidence for intrinsic thyrotropic activity of hCG, *J Clin Endocrinol Metab* 66:853, 1988.
178. **Kimura M, Amino N, Tamaki H, Mitsuda N, Miyai K, Tanizawa O**, Physiologic thyroid activation in normal early pregnancy is induced by circulating hCG, *Obstet Gynecol* 75:775, 1990.
179. **Ballabio M, Poshyachinda M, Ekins RP**, Pregnancy-induced changes in thyroid function: role of human chorionic gonadotropin as putative regulator of maternal thyroid, *J Clin Endocrinol Metab* 73:824, 1991.
180. **Kimura M, Amino N, Tamaki H, Ito E, Mitsuda N, Miyai K, Tanizawa O**, Gestational thyrotoxicosis and hyperemesis gravidarum: possible role of hCG with higher stimulating activity, *Clin Endocrinol (Oxf)* 38:345, 1993.
181. **Rodien P, Brémont C, Sanson ML, Parma J, Van Sande J, Costagliola S, Luton JP, Vassart G, Duprez L**, Familial gestational hyperthyroidism caused by a mutant thyrotropin receptor hypersensitive to human chorionic gonadotropin, *N Engl J Med* 339:1823, 1998.
182. **Panesar NS, Li CY, Rogers MS**, Are thyroid hormones or hCG responsible for hyperemesis gravidarum? A matched paired study in pregnant Chinese women, *Acta Obstet Gynecol Scand* 80:519, 2001.
183. **Tan JY, Loh KC, Yeo GS, Chee YC**, Transient hyperthyroidism of hyperemesis gravidarum, *Br J Obstet Gynaecol* 109:683, 2002.
184. **Hershman JM**, Human chorionic gonadotropin and the thyroid: hyperemesis gravidarum and trophoblastic tumors, *Thyroid* 9:653, 1999.
185. **Yamazaki K, Sato K, Shizume K, Kanaji Y, Ito Y, Obara T, Nakagawa T, Koizumi T, Nishimura R**, Potent thyrotropic activity of human chorionic gonadotropin variants in terms of <sup>125</sup>I incorporation and de novo synthesized thyroid hormone release in human thyroid follicles, *J Clin Endocrinol Metab* 80:473, 1995.
186. **Tsuruta E, Tada H, Tamaki H, Kashiwai T, Asahio K, Takeoka K, Mitsuda N, Amino N**, Pathogenic role of asialo human chorionic gonadotropin in gestational thyrotoxicosis, *J Clin Endocrinol Metab* 80:350, 1995.
187. **Rees LH, Buarke CW, Chard T, Evans SW, Letchorth AT**, Possible placental origin of ACTH in normal human pregnancy, *Nature* 254:620, 1975.
188. **Goland RS, Wardlaw SL, Blum M, Tropper PJ, Stark RI**, Biologically active corticotropin-releasing hormone in maternal and fetal plasma during pregnancy, *Am J Obstet Gynecol* 159:884, 1988.
189. **Goland R, Conwell I, Warren W, Wardlaw S**, Placental CRH and pituitary-adrenal function during pregnancy, *Neuroendocrinology* 56:749, 1992.
190. **Petraglia F, Sawchenko PE, Rivier J, Vale W**, Evidence for local stimulation of ACTH secretion by corticotropin-releasing factor in human placenta, *Nature* 328:717, 1987.
191. **Cooper ES, Greer IA, Brooks AN**, Placental proopiomelanocortin gene expression, adrenocorticotropin tissue concentrations, and immunostaining increase throughout gestation and are unaffected by prostaglandins, antiprogesterins, or labor, *J Clin Endocrinol Metab* 81:4462, 1996.
192. **Goland RS, Wardlaw SL, MacCarter G, Warren WB, Stark RI**, Adrenocorticotropin and cortisol responses to vasopressin during pregnancy, *J Clin Endocrinol Metab* 73:257, 1991.
193. **Laatikainen T, Virtanen T, Raioanen I, Salminen K**, Immunoreactive corticotropin releasing factor and corticotropin in plasma during pregnancy, labor and puerperium, *Neuropeptides* 10:343, 1987.
194. **Goland RS, Jozak S, Conwell I**, Placental corticotrophin-releasing hormone and the hypercortisolism of pregnancy, *Am J Obstet Gynecol* 171:1287, 1994.
195. **Westphal NJ, Seasholtz AF**, CRH-BP: the regulation and function of a phylogenetically conserved binding protein, *Front Biosci* 11:1878, 2006.
196. **Wolfe CDA, Patel SP, Linton EA, Campbell EA, Anderson J, Dornhorst A, Lowry PJ, Jones MT**, Plasma corticotrophin-releasing factor (CRH) in abnormal pregnancy, *Br J Obstet Gynaecol* 95:1003, 1988.
197. **Jones SA, Challis JRG**, Local stimulation of prostaglandin production by corticotropin-releasing hormone in human fetal membranes and placenta, *Biochem Biophys Res Commun* 159:192, 1989.
198. **Haig D**, Placental growth hormone-related proteins and prolactin-related proteins, *Placenta* 29(Suppl A):S36, 2008.
199. **Daughaday WH, Trivedi B, Winn HN, Yan H**, Hypersomatotropism in pregnant women, as measured by a

- human liver radioreceptor assay, *J Clin Endocrinol Metab* 70:215, 1990.
200. **Mirlesse V, Grankenne F, Alsat E, Poncelet M, Hennen G, Evain-Brion D**, Placental growth hormone levels in normal pregnancy and in pregnancies with intrauterine growth retardation, *Pediatr Res* 34:439, 1993.
  201. **Zeck W, Widberg C, Maylin E, Desoye G, Lang U, McIntyre D, Prins J, Russell A**, Regulation of placental growth hormone secretion in a human trophoblast model—the effects of hormones and adipokines, *Pediatr Res* 63:353, 2008.
  202. **Chellakooty M, Skibsted L, Skouby SO, Andersson A-M, Ptersen J, Main KM, Skakkebaek NE, Juul A**, Longitudinal study of serum placental GH in 455 normal pregnancies: correlation to gestational age, fetal gender, and weight, *J Clin Endocrinol Metab* 87:2734, 2002.
  203. **Papadopoulou E, Sifakis S, Giahnakis E, Fragouli Y, Karkavitsas N, Koumantakis E, Kalmanti M**, Human placental growth hormone is increased in maternal serum in pregnancies affected by Down syndrome, *Fetal Diagn Ther* 23:211, 2008.
  204. **Jauniaux E, Gulbis B, Jurkovic D, Schaaps JP, Campbell S, Meuris S**, Protein and steroid levels in embryonic cavities in early human pregnancy, *Hum Reprod* 8:782, 1993.
  205. **Keel BA, Eddy KB, Cho S, Gangrade BK, May JV**, Purified human alpha fetoprotein inhibits growth factor-stimulated estradiol production by porcine granulosa cells in monolayer culture, *Endocrinology* 130:3715, 1992.
  206. **Williams MA, Hickok DE, Zingheim RW, Luthy DA, Kimelman J, Nyberg DA, Mahony BS**, Elevated maternal serum  $\alpha$ -fetoprotein levels and midtrimester placental abnormalities in relation to subsequent adverse pregnancy outcomes, *Am J Obstet Gynecol* 167:1032, 1992.
  207. **Waller DK, Lustig LS, Cunningham GC, Feuchtbaum LB, Hook EB**, The association between maternal serum alpha-fetoprotein and preterm birth, small for gestational age infants, preeclampsia, and placental complications, *Obstet Gynecol* 88:816, 1996.
  208. **Gagnon A, Wilson RD**, Obstetrical complications associated with abnormal maternal serum markers analytes, *J Obstet Gynaecol Can* 217:918, 2008.
  209. **Baschat AA, Harman CR, Farid G, Chodirker BN, Evans JA**, Very low second-trimester maternal serum alpha-fetoprotein: association with high birth weight, *Obstet Gynecol* 99:531, 2002.
  210. **Phillips OP, Elias S, Shulman LP, Andersen RN, Morgan CD, Simpson JL**, Maternal serum screening for fetal Down syndrome in women less than 35 years of age using alpha-fetoprotein, hCG, and unconjugated estriol: a prospective 2-year study, *Obstet Gynecol* 80:353, 1992.
  211. **Haddow JE, Palomaki GE, Knoght GJ, Williams J, Pulkkinen A, Canick JA, Saller DN Jr, Bowers GB**, Prenatal screening for Down's syndrome with use of maternal serum markers, *N Engl J Med* 327:588, 1992.
  212. **Kellner LH, Weiner Z, Weiss RR, Neuer M, Martin GM, Mueenuddin M, Bombard A**, Triple marker ( $\alpha$ -fetoprotein, unconjugated estriol, human chorionic gonadotropin) versus  $\alpha$ -fetoprotein plus free- $\beta$  subunit in second-trimester maternal serum screening for fetal Down syndrome: a prospective comparison study, *Am J Obstet Gynecol* 173:1306, 1995.
  213. **Kazerouni NN, Currier B, Malm L, Riggle S, Hodgkinson C, Smith S, Tempelis C, Lorey F, Davis AJ, Jelffe-Pawlowski L, Walton-Haynes L, Roberson M**, Triple-marker prenatal screening program for chromosomal defects, *Obstet Gynecol* 114:50, 2009.
  214. **Saller DN, Canick JA, Schwartz S, Blitzer MG**, Multiple-marker screening in pregnancies with hydroptic and nonhydroptic Turner syndrome, *Am J Obstet Gynecol* 167:1021, 1992.
  215. **Benn PA, Kaminsky LM, Ying J, Borgida AF, Egan JF**, Combined second-trimester biochemical and ultrasound screening for Down syndrome, *Obstet Gynecol* 100:1168, 2002.
  216. **Benn PA, Fang M, Egan JF, Horne D, Collins R**, Incorporation of inhibin-A in second-trimester screening for Down syndrome, *Obstet Gynecol* 101:451, 2003.
  217. **Dugoff L, Cuckle HS, Hobbins JC, Malone FD, Belfort MA, Nyberg DA, Comstock CH, Saade GR, Eddleman KA, Dar P, Craigo S, Timor-Tritsch IE, Carr SR, Wolfe HM, D'Alton ME; for the FaSTER Trial Research Consortium**, Prediction of patient-specific risk for fetal loss using maternal characteristics and first- and second-trimester maternal serum Down syndrome markers, *Am J Obstet Gynecol* 199:290.e1,

2008.

218. **Wald NJ, Rodeck C, Hackshaw AK, Walters J, Chitty L, Mackinson AM**, First and second trimester antenatal screening for Down's syndrome: the results of the Serum, Urine and Ultrasound Screening Study (SURUSS), *Health Technol Assess* 7:1, 2003.
219. **Wapner R, Thom E, Simpson JL, Pergament E, Silver R, Filkins K, Platt L**, et al., for the **First Trimester Maternal Serum Biochemistry and Fetal Nuchal Translucency Screening (BUN) Study Group**, First-trimester screening for trisomies 21 and 18, *N Engl J Med* 349:1405, 2003.
220. **Tjoa ML, Cindrova-Davies T, Spasic-Boskovic O, Bianchi DW, Burton GJ**, Trophoblastic oxidative stress and the release of cell-free feto-placental DNA, *Am J Pathol* 169(2):400, 2006.
221. **Lui YY, Chik KW, Chiu RW, Ho CY, Lam CW, Lo YM**, Predominant hematopoietic origin of cell-free DNA in plasma and serum after sex-mismatched bone marrow transplantation, *Clin Chem* 48(3):421, 2002.
222. **Gil MM, Accurti V, Santacruz B, Plana MN, Nicolaides KH**, Analysis of cell-free DNA in maternal blood in screening for aneuploidies: updated meta-analysis, *Ultrasound Obstet Gynecol* 50(3):302, 2017.
223. **Committee on Practice Bulletins—Obstetrics, Committee on Genetics, and the Society for Maternal-Fetal Medicine**, Practice Bulletin No. 163: screening for fetal aneuploidy, *Obstet Gynecol* 127:e123, 2016.
224. **Kellner LH, Weiss RR, Weiner Z, Neuer M, Martin GM, Schulman H, Lipper S**, The advantages of using triple-marker screening for chromosomal abnormalities, *Am J Obstet Gynecol* 172:831, 1995.
225. **Weiss G, O'Byrne EM, Hochman J, Steinetz BG, Goldsmith L, Flitcraft JG**, Distribution of relaxin in women during pregnancy, *Obstet Gynecol* 52: 569, 1978.
226. **Fields PA, Larkin LH**, Purification and immunohistochemical localization of relaxin in the human term placenta, *J Clin Endocrinol Metab* 52:79, 1981.
227. **Lopez Bernal A, Bryant-Greenwood GD, Hansell DJ, Hicks BR, Greenwood FC, Turnbull AC**, Effect of relaxin on prostaglandin E production by human amnion: changes in relation to the onset of labour, *Br J Obstet Gynaecol* 94:1045, 1987.
228. **Quagliarello J, Steinetz BG, Weiss G**, Relaxin secretion in early pregnancy, *Obstet Gynecol* 53:62, 1979.
229. **Marnach ML, Ramin KD, Ramsey PS, Song S-W, Stensland JJ, An K-N**, Characterization of the relationship between joint laxity and maternal hormones in pregnancy, *Obstet Gynecol* 101:331, 2003.
230. **MacLennan AH, Katz M, Creasy R**, The morphologic characteristics of cervical ripening induced by the hormones relaxin and prostaglandin F<sub>2</sub>α in a rabbit model, *Am J Obstet Gynecol* 152:691, 1985.
231. **Hwang JJ, Macinga D, Rorke EA**, Relaxin modulates human cervical stromal cell activity, *J Clin Endocrinol Metab* 81:3379, 1996.
232. **Garibay-Tupas JL, Maaskant RA, Greenwood FC, Bryant-Greenwood GD**, Characteristics of the binding of 32P-labelled human relaxins to the human fetal membranes, *J Endocrinol* 145:441, 1995.
233. **Lowndes K, Amano A, Yamamoto S, Bryant-Greenwood GD**, The human relaxin receptor (LGR7): expression in the fetal membranes and placenta, *Placenta* 27:610, 2006.
234. **Kern A, Hubbard D, Amano A, Bryant-Greenwood GD**, Cloning, expression, and functional characterization of relaxin receptor (leucine-rich repeat-containing G protein-coupled receptor 7) splice variants from human fetal membranes, *Endocrinology* 149:1277, 2008.
235. **Bryant-Greenwood GD, Kern A, Yamamoto SY, Sadowsky DW, Novy MJ**, Relaxin and the human fetal membranes, *Reprod Sci* 14:42, 2007.
236. **Emmi AM, Skurnick J, Goldsmith LT, Gagliardi CL, Schmidt CL, Kleinberg D, Weiss G**, Ovarian control of pituitary hormone secretion in early human pregnancy, *J Clin Endocrinol Metab* 72:1359, 1991.
237. **Bani D**, Relaxin as a natural agent for vascular health, *Vasc Health Risk Manag* 4:515, 2008.
238. **van der Westhuizen ET, Halls ML, Samuel CS, Bathgate RA, Unemori EN, Sutton SW, Summers RJ**, Relaxin family peptide receptors—from orphans to therapeutic targets, *Drug Discov Today* 13:640, 2008.
239. **Simon C, Einspanier A**, The hormonal induction of cervical remodeling in the common marmoset monkey (*Callithrix jacchus*), *Reproduction* 137:517, 2009.
240. **Daly DC, Kuslis S, Riddick DH**, Evidence of short-loop inhibition of decidual prolactin synthesis by decidual proteins, Part II, *Am J Obstet Gynecol* 155:363, 1986.
241. **Maslar IA, Ansbacher R**, Effects of progesterone on decidual prolactin production by organ cultures of

- human endometrium, *Endocrinology* 118:2102, 1986.
242. **Daly DC, Kuslis S, Riddick DH**, Evidence of short-loop inhibition of decidual prolactin synthesis by decidual proteins, Part I, *Am J Obstet Gynecol* 155:358, 1986.
  243. **Handwerger S, Brar A**, Placental lactogen, placental growth hormone, and decidual prolactin, *Semin Reprod Endocrinol* 10:106, 1992.
  244. **Reis FM, Vigano P, Arnaboldi E, Spritzer PM, Petraglia F, Di Blasio AM**, Expression of prolactin-releasing peptide and its receptor in the human decidua, *Mol Hum Reprod* 8:356, 2002.
  245. **Brar AK, Kessler CA, Handwerger S**, An Ets motif in the proximal decidual prolactin promoter is essential for basal gene expression, *J Mol Endocrinol* 29:99, 2002.
  246. **McCoshen JA, Barc J**, Prolactin bioactivity following decidual synthesis and transport by amniochorion, *Am J Obstet Gynecol* 153:217, 1985.
  247. **Gellersen B, DiMattia G, Friesen HG, Bohnet H**, Prolactin (PRL) mRNA from human decidua differs from pituitary PRL mRNA but resembles IM-9-P3 lymphoblast PRL transcript, *Mol Cell Endocrinol* 64:127, 1989.
  248. **Tyson JE, Hwang P, Guyda H, Friesen HG**, Studies of prolactin secretion in human pregnancy, *Am J Obstet Gynecol* 113:14, 1972.
  249. **Kletzky OA, Marrs RP, Howard WF, McCormick W, Mishell DR Jr**, Prolactin synthesis and release during pregnancy and puerperium, *Am J Obstet Gynecol* 136:545, 1980.
  250. **Tyson JE, Friesen HG**, Factors influencing the secretion of human prolactin and growth hormone in menstrual and gestational women, *Am J Obstet Gynecol* 116:377, 1973.
  251. **Barberia JM, Abu-Fadil S, Kletzky OA, Nakamura RM, Mishell DR Jr**, Serum prolactin patterns in early human gestation, *Am J Obstet Gynecol* 121: 1107, 1975.
  252. **Ho Yuen B, Cannon W, Lewis J, Sy L, Wooley S**, A possible role for prolactin in the control of human chorionic gonadotropin and estrogen secretion by the fetoplacental unit, *Am J Obstet Gynecol* 136:286, 1980.
  253. **Maaskant RA, Bogic LV, Gilger S, Kelly PA, Bryant-Greenwood GD**, The human prolactin receptor in the fetal membranes, decidua, and placenta, *J Clin Endocrinol Metab* 81:396, 1996.
  254. **Luciano AA, Varner MW**, Decidual, amniotic fluid, maternal, and fetal prolactin in normal and abnormal pregnancies, *Obstet Gynecol* 63:384, 1984.
  255. **Golander A, Kopel R, Lasebik N, Frenkel Y, Spirer Z**, Decreased prolactin secretion by decidual tissue of pre-eclampsia in vitro, *Acta Endocrinol* 108:111, 1985.
  256. **Healy DL, Herington AC, O'Herlihy C**, Chronic polyhydramnios is a syndrome with a lactogen receptor defect in the chorion laeva, *Br J Obstet Gynaecol* 92:461, 1985.
  257. **Raabe MA, McCoshen JA**, Epithelial regulation of prolactin effect on amniotic permeability, *Am J Obstet Gynecol* 154:130, 1986.
  258. **Pullano JG, Cohen-Addad N, Apuzzio JJ, Ganesh VL, Josimovich JB**, Water and salt conservation in the human fetus and newborn. I. Evidence for a role of fetal prolactin, *J Clin Endocrinol Metab* 69:1180, 1989.
  259. **Ben-Rafael Z, Orvieto R**, Cytokines—involvement in reproduction, *Fertil Steril* 58:1093, 1992.
  260. **Harty JR, Kauma SW**, Interleukin-1 stimulates colony-stimulating factor-1 production in placental villous core mesenchymal cells, *J Clin Endocrinol Metab* 75:947, 1992.
  261. **Masuhiko K, Matsuzaki N, Nishino E, Taniguchi T, Kameda T, Li Y, Saji F, Tanizawa O**, Trophoblast-derived interleukin-1 (IL-1) stimulates the release of human chorionic gonadotropin by activating IL-6 and IL-6-receptor system in first trimester human trophoblasts, *J Clin Endocrinol Metab* 72:594, 1991.
  262. **Li Y, Matsuzaki N, Masuhiko K, Kameda T, Tamiguchi T, Saji F, Yone K, Tanizawa O**, Trophoblast-derived tumor necrosis factor induces release of human chorionic gonadotropin using interleukin-6 (IL-6) and IL-6-receptor-dependent system in the normal human trophoblasts, *J Clin Endocrinol Metab* 74:184, 1992.
  263. **Pekonen F, Suikkari A-M, Makinen T, Rutanen E-M**, Different insulin-like growth factor binding species in human placenta and decidua, *J Clin Endocrinol Metab* 67:1250, 1988.
  264. **Sferruzzi-Perri AN, Owens JA, Pringle KG, Robinson JS, Roberts CT**, Maternal insulin-like growth factors-I and -II act via different pathways to promote fetal growth, *Endocrinology* 147:3344, 2006. doi:10.1210/en.2005-1328.

265. **Del Rincon JP, Iida K, Gaylinn BD, Mccurdy CE, Leitner JW, Barbour LA, Kopchick JJ, Friedman JE, Draznin B, Thorner MO**, Growth hormone regulation of p85alpha expression and phosphoinositide 3-kinase activity in adipose tissue: mechanism for growth hormone-mediated insulin resistance, *Diabetes* 56:1638, 2007. doi:10.2337/db06-0299.
266. **Modi H, Jacovetti C, Tarussio D, Metref S, Madsen OD, Zhang FP, Rantakari P, Poutanen M, Nef S, Gorman T, Regazzi R, Thorens B**, Autocrine action of IGF2 regulates adult beta-cell mass and function, *Diabetes* 64:4148, 2015. doi:10.2337/db14-1735.
267. **Sferruzzi-Perri AN, Vaughan OR, Coan PM, Suciu MC, Darbyshire R, Constancia M, Burton GJ, Fowden AL**, Placental-specific Igf2 deficiency alters developmental adaptations to undernutrition in mice, *Endocrinology* 152:3202, 2011. doi:10.1210/en.2011-0240.
268. **Napso T, Yong HE, Lopez-Tello J, Sferruzzi-Perri AN**, The role of placental hormones in mediating maternal adaptations to support pregnancy and lactation, *Front Physiol* 9:1091, 2018. doi:10.3389/fphys.2018.01091. eCollection 2018.
269. **Giudice LC, Farrell EM, Pham H, Lamson G, Rosenfeld RG**, Insulin-like growth factor binding proteins in maternal serum throughout gestation and in the puerperium: effects of a pregnancy-associated serum protease activity, *J Clin Endocrinol Metab* 71:806, 1990.
270. **Tennekoon KH, Pathmaperuma AN, Senanayake L, Karunanayake EH**, Insulin-like growth factors-I and -II and insulin-like growth factor binding protein-1 during normal pregnancy: pattern of secretion and correlation with other placental hormones, *Ceylon Med J* 52:8, 2007.
271. **Langford KS, Nicolaidis KH, Jones J, Abbas A, McGregor AM, Miell JP**, Serum insulin-like growth factor-binding protein-3 (IGFBP-3) levels and IGFBP-3 protease activity in normal, abnormal, and multiple human pregnancy, *J Clin Endocrinol Metab* 80:21, 1995.
272. **Osborn BH, Fowlkes J, Han VKM, Fremark M**, Nutritional regulation of insulin-like growth factor-binding protein gene expression in the ovine fetus and pregnant ewe, *Endocrinology* 131:1743, 1992.
273. **Iwashita M, Kobayashi M, Matsuo A, Nakayama S, Mimuro T, Takeda Y, Sakamoto S**, Feto-maternal interactions of IGF-I and its binding proteins in fetal growth, *Early Hum Dev* 29:187, 1992.
274. **Lassarre C, Hardouin S, Daffos F, Forestier F, Frankenne F, Binoux M**, Serum insulin-like growth factors and insulin-like growth factor binding proteins in the human fetus. Relationships with growth in normal subjects and in subjects with intrauterine growth retardation, *Pediatr Res* 29:219, 1991.
275. **Gluckman PD**, The endocrine regulation of fetal growth in late gestation: the role of insulin-like growth factors, *J Clin Endocrinol Metab* 80:1047, 1995.
276. **Abe Y, Hasegawa Y, Miyamoto K, Yamaguchi M, Andoh A, Ibuki Y**, High concentrations of plasma immunoreactive inhibin during normal pregnancy in women, *J Clin Endocrinol Metab* 71:133, 1990.
277. **Qu J, Ying S-Y, Thomas K**, Inhibin production and secretion in human placental cells cultured in vitro, *Obstet Gynecol* 79:705, 1992.
278. **Muttukrishna S, George L, Fowler PA, Groome NP, Knight PG**, Measurement of serum concentrations of dimeric inhibin during human pregnancy, *Clin Endocrinol* 42:391, 1994.
279. **Qu J, Thomas K**, Inhibin and activin production in human placenta, *Endocr Rev* 16:485, 1995.
280. **Illingworth PJ, Groome NP, Duncan WC, Grant V, Tovanabutra S, Baird DT, McNeilly AS**, Measurement of circulating inhibin forms during the establishment of pregnancy, *J Clin Endocrinol Metab* 81:1471, 1996.
281. **Lahiri S, Anobile CJ, Stewart P, Ledger WL**, Changes in circulating concentrations of inhibins A and pro-alpha C during first trimester medical termination of pregnancy, *Hum Reprod* 18:744, 2003.
282. **Muttukrishna S, Fowler PA, George L, Groome NP, Knight PG**, Changes in peripheral serum levels of total activin A during the human menstrual cycle and pregnancy, *J Clin Endocrinol Metab* 81:3328, 1996.
283. **Petraglia F, Woodruff TK, Botticelli G, Botticelli A, Genazzani AR, Mayo KE, Vale W**, Gonadotropin-releasing hormone, inhibin, and activin in human placenta: evidence for a common cellular localization, *J Clin Endocrinol Metab* 74:1184, 1992.
284. **Petraglia F, Anceschi MM, Calza L, Garuti GC, Fusaro P, Giardino L, Genazzani AR, Vale W**, Inhibin and activin in human fetal membranes: evidence for a local effect on prostaglandin release, *J Clin Endocrinol*

Metab 77:542, 1993.

285. **Bersinger NA, Smarason AK, Muttukrishna S, Groome NP, Redman CW**, Women with preeclampsia have increased serum levels of pregnancy-associated plasma protein A (PAPP-A), inhibin A, activin A and soluble E-selectin, *Hypertens Pregnancy* 22:45, 2003.
286. **Petraglia F, Gallinelli A, Grande A, Florio P, Ferrari S, Genazzani AR, Ling N, DePaolo V**, Local production and action of follistatin in human placenta, *J Clin Endocrinol Metab* 78:205, 1994.
287. **Hung TT**, The role of endogenous opioids in pregnancy and anesthesia, *Semin Reprod Endocrinol* 5:161, 1987.
288. **Xie G-X, Miyajima A, Goldstein A**, Expression cloning of cDNA encoding a seven-helix receptor from human placenta with affinity for opioid ligands, *Proc Natl Acad Sci U S A* 89:4124, 1992.
289. **Margioris AN, Grino M, Protos P, Gold PW, Chrousos GP**, Corticotropin-releasing hormone and oxytocin stimulate the release of placental proopiomelanocortin peptides, *J Clin Endocrinol Metab* 66:922, 1988.
290. **Derckx FHM, Alberda AT, De Jong FH, Zeilmaker FH, Makovitz JW, Schalekamp MADH**, Source of plasma prorenin in early and late pregnancy: observations in a patient with primary ovarian failure, *J Clin Endocrinol Metab* 65:349, 1987.
291. **Itskovitz J, Rubattu S, Levron J, Sealey JE**, Highest concentrations of prorenin and human chorionic gonadotropin in gestational sacs during early human pregnancy, *J Clin Endocrinol Metab* 75:906, 1992.
292. **Lenz T, Sealey JE, August P, James GD, Laragh JH**, Tissue levels of active and total renin, angiotensinogen, human chorionic gonadotrophin, estradiol, and progesterone in human placentas from different methods of delivery, *J Clin Endocrinol Metab* 69:31, 1989.
293. **Myatt L**, Control of vascular resistance in the human placenta, *Placenta* 13:329, 1992.
294. **August P, Mueller FB, Sealey JE, Edersheim TG**, Role of renin-angiotensin system in blood pressure regulation in pregnancy, *Lancet* 345:896, 1995.
295. **Lim AT, Gude NM**, Atrial natriuretic factor production by the human placenta, *J Clin Endocrinol Metab* 80:3091, 1995.
296. **Yamaji T, Hirai N, Ishibashi M, Takaku F, Yanaihara T, Nakayama T**, Atrial natriuretic peptide in umbilical cord blood: evidence for a circulating hormone in human fetus, *J Clin Endocrinol Metab* 63:1414, 1986.
297. **Pouta AM, Rasanen JP, Airaksinen KE, Vuolteenaho OJ, Laatikainen TJ**, Changes in maternal heart dimensions and plasma atrial natriuretic peptide levels in the early puerperium of normal and preeclamptic pregnancies, *Br J Obstet Gynaecol* 103:988, 1996.
298. **Di Lieto A, Pollio F, Catalano D, Gallo F, De Falco M, Minutolo R, Memoli B**, Atrial natriuretic factor in amniotic fluid and in maternal venous blood of pregnancies with fetal cardiac malformations and chromosomal abnormalities, *J Matern Fetal Neonatal Med* 11:183, 2002.
299. **Cameron VA, Ellmers LJ**, Minireview: natriuretic peptides during development of the fetal heart and circulation, *Endocrinology* 144:2191, 2003.
300. **Cootauco AC, Murphy JD, Maleski J, Blakemore KJ, Slodzinski MK**, Atrial natriuretic peptide production and natriuretic peptide receptors in the human uterus and their effect on myometrial relaxation, *Am J Obstet Gynecol* 199:429.e1, 2008.
301. **Morton H, Rolfe BE, Cavanagh AC**, Early pregnancy factor, *Semin Reprod Endocrinol* 10:72, 1992.
302. **Chou JY, Plouzek CA**, Pregnancy-specific 1-glycoprotein, *Semin Reprod Endocrinol* 10:116, 1992.
303. **Levine RJ, Lam C, Qian C, Yu KF, Maynard SE, Sachs BP, Sibai BM, Epstein FH, Romero R, Thadhani R, Karumanchi SA; CPEP Study Group**, Soluble endoglin and other circulating antiangiogenic factors in preeclampsia, *N Engl J Med* 355:992, 2006.
304. **Levine RJ, Maynard SE, Qian C, Lim KH, England LJ, Yu KF, Schisterman EF, Thadhani R, Sachs BP, Epstein FH, Sibai BM, Sukhatme VP, Karumanchi SA**, Circulating angiogenic factors and the risk of preeclampsia, *N Engl J Med* 350:672, 2004.
305. **Venkatesha S, Toporsian M, Lam C, Hanai J, Mammoto T, Kim YM, Bdolah Y, Lim KH, Yuan HT, Libermann TA, Stillman IE, Roberts D, D'Amore PA, Epstein FH, Sellke FW, Romero R, Sukhatme VP, Letarte M, Karumanchi SA**, Soluble endoglin contributes to the pathogenesis of preeclampsia, *Nat Med* 12:642, 2006.



306. **Myatt L, Clifton RG, Roberts JM**, et al., First-trimester prediction of preeclampsia in nulliparous women at low risk, *Obstet Gynecol* 119:1234, 2012.
307. **Kusanovic JP, Romero R, Chaiworapongsa T, Erez O, Mittal P, Vaisbuch E, Mazaki-Tovi S, Gotsch F, Edwin SS, Gomez R, Yeo L, Conde-Agudelo A, Hassan SS**, A prospective cohort study of the value of maternal plasma concentrations of angiogenic and anti-angiogenic factors in early pregnancy and midtrimester in the identification of patients destined to develop preeclampsia, *J Matern Fetal Neonatal Med* 22:1021, 2009.
308. **Holmes VA, Young IS, Patterson CC, Maresh MJ, Pearson DW, Walker JD, McCance DR; Diabetes and Preeclampsia Intervention Trial (DAPIT) Study Group**, The role of angiogenic and antiangiogenic factors in the second trimester in the prediction of preeclampsia in pregnant women with type 1 diabetes, *Diabetes Care* 36(11):3671, 2013. doi:10.2337/dc13-0944.
309. **Ramwell PW, Foegh M, Loeb R, Leovey EMK**, Synthesis and metabolism of prostaglandins, prostacyclin, and thromboxanes: the arachidonic acid cascade, *Semin Perinatol* 4:3, 1980.
310. **Smith WL, Marnett LJ, DeWitt DL**, Prostaglandin and thromboxane biosynthesis, *Pharmacol Ther* 49:153, 1991.
311. **Samuelsson B, Dahlen S-E, Lindgren JA, Rouzer CA, Serhan CN**, Leukotrienes and lipoxins: structures, biosynthesis, and biological effects, *Science* 237:1171, 1987.
312. **Funk CD, Funk LB, Kennedy ME, Pong AS, FitzGerald GA**, Human platelet/erythrocyte cell prostaglandin G/H synthase: cDNA cloning, expression and gene chromosomal assignment, *FASEB J* 5:2304, 1991.
313. **Jones DA, Carlton DP, McIntyre TM, Zimmerman GA, Prescott SM**, Molecular cloning of human prostaglandin endoperoxide synthase type II and demonstration of expression in response to cytokines, *J Biol Chem* 268:9049, 1993.
314. **Williams CS, Du Bois RN**, Prostaglandin endoperoxide synthase: why two isoforms? *Am J Physiol* 270:393, 1996.
315. **Gryglewski RJ, Korbut R, Oetkiewicz A, Splawinski J, Wojtaszek B, Swies J**, Lungs as a generator of prostacyclin—hypothesis on physiological significance, *Naunyn Schmiedebergs Arch Pharmacol* 304:45, 1979.
316. **Walsh SW**, Preeclampsia: an imbalance in placental prostacyclin and thromboxane production, *Am J Obstet Gynecol* 152:335, 1985.
317. **Beitz J, Muller G, Forster W**, Effect of HDL and LDL from pre and post menopausal women on prostacyclin synthesis, *Prostaglandins* 30:179, 1985.
318. **Mileikowsky GN, Nadler JL, Huey F, Francis R, Roy S**, Evidence that smoking alters prostacyclin formation and platelet aggregation in women who use oral contraceptives, *Am J Obstet Gynecol* 159:1547, 1988.
319. **Makheja A, Vanderhoek JY, Bailey JM**, Inhibition of platelet aggregation and thromboxane synthesis by onion and garlic, *Lancet* 1:781, 1979.
320. **Fischer S, Weber PC**, The prostacyclin/thromboxane balance is favourably shifted in Greenland Eskimos, *Prostaglandins* 32:235, 1986.
321. **Olson DM, Zakart T**, Intrauterine tissue prostaglandin synthesis: regulatory mechanisms, *Semin Reprod Endocrinol* 11:234, 1993.
322. **Green K, Drvota V, Vesterqvist O**, Pronounced reduction of in vivo prostacyclin synthesis in humans by acetaminophen (paracetamol), *Prostaglandins* 37:311, 1989.
323. **Mitchell JA, Akarasereenont P, Thiemermann C, Flower RJ, Vane JR**, Selectivity of nonsteroidal antiinflammatory drugs as inhibitors of constitutive and inducible cyclooxygenase, *Proc Natl Acad Sci U S A* 90:11693, 1993.
324. **Davis BJ, Lennard DE, Lee CA, Tiano HF, Morham SG, Wetsel WK, Langenbach R**, Anovulation in cyclooxygenase-2-deficient mice is restored by prostaglandin E2 and interleukin-1 $\beta$ , *Endocrinology* 140:2685, 1999.
325. **Pall M, Fridén BE, Brännström M**, Induction of delayed follicular rupture in the human by the selective COX-2 inhibitor rofecoxib: a randomized double-blind study, *Hum Reprod* 16:1323, 2001.
326. **Masotti G, Poggesi L, Galanti G, Abbate R, Neri S, Neri GG**, Differential inhibition of prostacyclin

production and platelet aggregation by aspirin, *Lancet* 2:1213, 1979.

327. **Bochner F, Lloyd J**, Is there an optimal dose and formulation of aspirin to prevent arterial thrombo-embolism in man? *Clin Sci* 71:625, 1987.
328. **FitzGerald DJ, Mayo G, Catella F, Entman SS, FitzGerald GA**, Increased thromboxane biosynthesis in normal pregnancy is mainly derived from platelets, *Am J Obstet Gynecol* 157:325, 1987.
329. **Baron JA, Sandler RS, Bresalier RS, Lanos A, Morton DG, Riddell R, Iverson ER, DeMets DL**, Cardiovascular events associated with rofecoxib: final analysis of the APPROVe trial, *Lancet* 372:1756, 2008.
330. **McLean M, Bisit A, Davies J, Woods R, Lowry PJ, Smith R**, A placental clock controlling the length of human pregnancy, *Nat Med* 1:460, 1995.
331. **Sandman CA, Glynn L, Schetter CD, Wadhwa P, Garite T, Chicz-DeMet A, Hobel C**, Elevated maternal cortisol early in pregnancy predicts third trimester levels of placental corticotropin releasing hormone (CRH): priming the placental clock, *Peptides* 27(6):1457, 2006.
332. **Norwitz ER, Bonney EA, Snegovskikh VV, Williams MA, Phillippe M, Park JS, Abrahams VM**, Molecular regulation of parturition: the role of the decidual clock, *Cold Spring Harb Perspect Med* 5(11):a023143, 2015.
333. **Mitchell MD**, Mechanisms of human parturition: role of prostaglandins and related compounds, *Adv Prostaglandin Thromboxane Leukot Res* 15:613, 1985.
334. **Casey ML, MacDonald PC**, The initiation of labor in women: regulation of phospholipid and arachidonic acid metabolism and of prostaglandin production, *Semin Perinatol* 10:270, 1986.
335. **Challis JRG, Gibb W**, Control of parturition, *Prenatal Neonatal Med* 1:283, 1996.
336. **Smith R, Mesiano S, McGrath S**, Hormone trajectories leading to human birth, *Regul Pept* 108:159, 2002.
337. **Challis JRG, Matthews SG, Gibb W, Lye SJ**, Endocrine and paracrine regulation of birth at term and preterm, *Endocr Rev* 21:514, 2000.
338. **Lopez Bernal A**, Mechanisms of labour—biochemical aspects, *BJOG* 110(Suppl 20):39, 2003.
339. **Snegovskikh V, Park JS, Norwitz ER**, Endocrinology of parturition, *Endocrinol Metab Clin North Am* 35:173, 2006.
340. **Honnebier WJ, Swaab DF**, The influence of anencephaly upon intrauterine growth of fetus and placenta and upon gestation length, *J Obstet Gynaecol Br Commonw* 80:577, 1973.
341. **Walsh SW, Stanczyk FZ, Novy MJ**, Daily hormonal changes in the maternal, fetal and amniotic fluid compartments before parturition in a primate species, *J Clin Endocrinol Metab* 58:629, 1984.
342. **Femini M, Borenstein R, Dreazen E, Aelman Z, Mogilner BM, Kessler I, Lancet M**, Prevention of premature labor by 17 $\alpha$ -hydroxyprogesterone caproate, *Am J Obstet Gynecol* 151:574, 1985.
343. **Erny R, Pigne A, Prouvost C, Gamarre M, Malet C, Serment H, Barrat J**, The effects of oral administration of progesterone for premature labor, *Am J Obstet Gynecol* 154:525, 1986.
344. **Johnson JWC, Austin KL, Jones GS, Davis GH, King TM**, Efficacy of 17 $\alpha$ -hydroxyprogesterone caproate in the prevention of premature labor, *N Engl J Med* 293:675, 1975.
345. **Meis PJ, Klebanoff M, Thom E**, et al., Prevention of recurrent pre-term delivery by 17 alpha-hydroxyprogesterone caproate, *N Engl J Med* 348:2379, 2003.
346. **Khan-Dawood FS**, In vitro conversion of pregnenolone to progesterone in human term placenta and fetal membranes before and after onset of labor, *Am J Obstet Gynecol* 157:1333, 1987.
347. **Haluska GJ, Wells TR, Hirst JJ, Brenner RM, Sadowsky DW, Novy MJ**, Progesterone receptor localization and isoforms in myometrium, decidua, and fetal membranes from rhesus macaques: evidence for functional progesterone withdrawal, *J Soc Gynecol Investig* 9:125, 2002.
348. **Mesiano S, Chan E-C, Fitter JT, Kwok K, Yeo G, Smith R**, Progesterone withdrawal and estrogen activation in human parturition are coordinated by progesterone receptor A expression in the myometrium, *J Clin Endocrinol Metab* 87:2924, 2002.
349. **Condon JC, Hardy DB, Kovaric K, Mendelson CR**, Up-regulation of the progesterone receptor (PR)-C isoform in laboring myometrium by activation of nuclear factor-kappaB may contribute to the onset of labor through inhibition of PR function, *Mol Endocrinol* 20:764, 2006.
350. **Taylor AH, McParland PC, Taylor DJ, Bell SC**, The progesterone receptor in human term amniochorion and

placenta is isoform C, *Endocrinology* 147:687, 2006.

351. **Merlino AA, Welsh TN, Tan H, Yi LJ, Cannon V, Mercer BM, Mesiano S**, Nuclear progesterone receptors in the human pregnancy myometrium: evidence that parturition involves functional progesterone withdrawal mediated by increased expression of progesterone receptor-A, *J Clin Endocrinol Metab* 92:1927, 2007.
352. **Madsen G, Zakar T, Ku CY, Sanborn BM, Smith R, Mesiano S**, Prostaglandins differentially modulate progesterone receptor-A and -B expression in human myometrial cells: evidence for prostaglandin-induced functional progesterone withdrawal, *J Clin Endocrinol Metab* 89:1010, 2004.
353. **Haluska GJ, Stanczyk FZ, Cook MJ, Novy MJ**, Temporal changes in uterine activity and prostaglandin response to RU 486 in rhesus macaques in late gestation, *Am J Obstet Gynecol* 157:1487, 1987.
354. **Selinger M, MacKenzie IZ, Gillmet MD, Phipps SL, Ferguson J**, Progesterone inhibition in mid-trimester termination of pregnancy: physiological and clinical effects, *Br J Obstet Gynaecol* 94:1218, 1987.
355. **Haluska GJ, Cook MJ, Novy MJ**, Inhibition and augmentation of progesterone production during pregnancy: effects on parturition in rhesus monkeys, *Am J Obstet Gynecol* 176:682, 1997.
356. **Mitchell BF, Wong S**, Changes in  $17\beta,20\alpha$ -hydroxysteroid dehydrogenase activity supporting an increase in the estrogen/progesterone ratio of human fetal membranes at parturition, *Am J Obstet Gynecol* 168:1377, 1993.
357. **Condon JC, Jeyasuria P, Faust JM, Wilson JW, Mendelson C**, A decline in the levels of progesterone receptor coactivators in the pregnant uterus at term may antagonize progesterone receptor function and contribute to the initiation of parturition, *Proc Natl Acad Sci* 100:9518, 2003.
358. **Davidson BJ, Murray RD, Challis JRG, Valenzuela GJ**, Estrogen, progesterone, prolactin, prostaglandin E<sub>2</sub>, prostaglandin F<sub>2</sub> $\alpha$ , 13,14-dihydro-15-keto-prostaglandin F<sub>2</sub> $\alpha$ , and 6-keto-prostaglandin F<sub>1</sub> $\alpha$  gradients across the uterus in women in labor and not in labor, *Am J Obstet Gynecol* 157:54, 1987.
359. **Sanchez-Ramos L, Kaunitz AM, Delke I**, Progesterone agents to prevent preterm birth: a meta-analysis of randomized controlled trials, *Obstet Gynecol* 105:273, 2005.
360. **Meis PJ**; for the **Society for Maternal-Fetal Medicine**, 17 Hydroxyprogesterone for the prevention of preterm delivery, *Obstet Gynecol* 105:1128, 2005.
361. **Rouse DJ, Caritis SN, Peaceman AM, Sciscione A, Thorn EA, Spong CY, Varner M, Malone FD, Iams JD, Mercer BM, Thorp J, Sorokin Y, Carpenter M, Lo J, Ramion S, Harpter M, Anderson G**; for the **National Institute of Child Health and Human Development Maternal-Fetal Medicine Units Network**, A trial of 17 alpha-hydroxyprogesterone caproate to prevent prematurity in twins, *N Engl J Med* 357:454, 2007.
362. **Dodd JM, Flenady VJ, Cincotta R, Crowther CA**, Progesterone for the prevention of preterm birth. A systematic review, *Obstet Gynecol* 112:127, 2008.
363. **Carits SN, Rouse DJ, Peaceman AM, Sciscione A, Momirova V, Spong CY, Iams JD, Wapner RJ, Varner M, Carpenter M, Lo J, Thorp J, Mercer BM, Sorokin Y, Harper M, Ramin S, Anderson G**; for the **Eunice Kennedy Shriver national Institute of Child Health and Human Development (NICHD) M-FMUNM**, Prevention of preterm birth in triplets using 17 alpha-hydroxyprogesterone caproate. A randomized controlled trial, *Obstet Gynecol* 113:285, 2009.
364. **Okazaki T, Sagawa N, Okita JR, Bleasdale JE, MacDonald PC, Johnston JM**, Diacylglycerol metabolism and arachidonic acid release in human fetal membranes and decidua vera, *J Biol Chem* 256:7316, 1981.
365. **Okazaki T, Sagawa N, Bleasdale JE, Okita JR, MacDonald PC, Johnston JM**, Initiation of human parturition: XIII. Phospholipase C, phospholipase A<sub>2</sub>, and diacylglycerol lipase activities in fetal membranes and decidua vera tissues from early and late gestation, *Biol Reprod* 25:103, 1981.
366. **DiRenzo GC, Johnston JM, Okazaki T, Okita JR, MacDonald PC, Bleasdale JE**, Phosphatidylinositol specific phospholipase C in fetal membranes and uterine decidua, *J Clin Invest* 67:847, 1981.
367. **Andersson S, Minjarez D, Yost NP, Word RA**, Estrogen and progesterone metabolism in the cervix during pregnancy and parturition, *J Clin Endocrinol Metab* 93:2366, 2008.
368. **Romano WM, Lukash LA, Challis JRG, Mitchell BF**, Substrate utilization for estrogen synthesis by human fetal membranes and decidua, *Am J Obstet Gynecol* 155:11700, 1986.

369. **Chibbar R, Hobkirk R, Mitchell BF**, Sulfohydrolase activity for estrone sulfate and dehydroepiandrosterone sulfate in human fetal membranes and decidua around the time of parturition, *J Clin Endocrinol Metab* 62:90, 1986.
370. **Challis JRG, Vaughan M**, Steroid synthetic and prostaglandin metabolizing activity is present in different cell populations from human fetal membranes and decidua, *Am J Obstet Gynecol* 157:1474, 1987.
371. **Collins PL, Moore JJ, Idriss E, Kulp TM**, Human fetal membranes inhibit calcium L-channel activated uterine contractions, *Am J Obstet Gynecol* 175:1173, 1996.
372. **Florio P, Woods RJ, Genazzani AR, Lowry PJ, Petraglia F**, Changes in amniotic fluid immunoreactive corticotropin-releasing factor (CRF) and CRF-binding protein levels in pregnant women at term and during labor, *J Clin Endocrinol Metab* 82:835, 1997.
373. **Klimaviciute A, Calciolari J, Bertucci E, Abelin-Tornblöm S, Stjernholm-Vladic Y, Byström B, Petraglia F, Ekman-Ordeberg G**, Corticotropin-releasing hormone, its binding protein and receptors in human cervical tissue at preterm and term labor in comparison to non-pregnant state, *Reprod Biol Endocrinol* 4:29, 2006.
374. **Bendetto C, Petraglia F, Marozio L, Florio P, Genazzani AR, Massobrio M**, CRH increases prostaglandin F2 $\alpha$  in human myometrium in vitro, *Am J Obstet Gynecol* 171:126, 1994.
375. **Berkowitz GS, Lapinski RH, Lockwood CJ, Florio P, Blackmore-Prince C, Petraglia F**, Corticotropin-releasing factor and its binding protein: maternal serum levels in term and preterm deliveries, *Am J Obstet Gynecol* 174:1477, 1996.
376. **Korebrits C, Ramirez MM, Watson L, Brinkman E, Bocking AD, Challis JRG**, Maternal corticotropin-releasing hormone is increased with impending preterm birth, *J Clin Endocrinol Metab* 83:1585, 1998.
377. **McGrath S, McLean M, Smith D, Bisits A, Giles W, Smith R**, Maternal plasma corticotropin-releasing hormone trajectories vary depending on the cause of preterm delivery, *Am J Obstet Gynecol* 186:257, 2002.
378. **Marinoni E, Korebrits C, Di Iorio R, Cosmi EV, Challis JRG**, Effect of betamethasone in vivo on placental corticotropin-releasing hormone in human pregnancy, *Am J Obstet Gynecol* 178:770, 1998.
379. **Florio P, Lombardo M, Gallo R, Di Carlo C, Sutton SW, Genazzani AR, Petraglia F**, Activating A, corticotropin-releasing factor and prostaglandin F2  $\alpha$  increase immunoreactive oxytocin release from cultured human placental cells, *Placenta* 17:307, 1996.
380. **Robinson BG, Arbiser JL, Emanuel RL, Majzoub JA**, Species-specific placental corticotropin releasing hormone messenger RNA and peptide expression, *Mol Cell Endocrinol* 62:337, 1989.
381. **Ni X, Nicholson RC, King BR, Chan E-C, Read MA, Smith R**, Estrogen represses whereas the estrogen-antagonist ICI 182780 stimulates placental CRH gene expression, *J Clin Endocrinol Metab* 87:3774, 2002.
382. **Cheng YH, Nicholson RC, King B, Chan EC, Fitter JT, Smith R**, Glucocorticoid stimulation of corticotropin-releasing hormone gene expression requires a cyclic adenosine 3',5'-monophosphate regulatory element in human primary placental cytotrophoblast cells, *J Clin Endocrinol Metab* 85:1937, 2000.
383. **Ni X, Hou Y, King BR, Tang X, Read MA, Smith R, Nicholson RC**, Estrogen receptor-mediated down-regulation of corticotrophin-releasing hormone gene expression is dependent on a cyclic adenosine 3',5'-monophosphate regulatory element in human placental syncytiotrophoblast cells, *J Clin Endocrinol Metab* 89:2312, 2004.
384. **Ni X, Hou Y, Yang R, Tang X, Smith R, Nicholson RC**, Progesterone receptors A and B differentially modulate corticotropin-releasing hormone gene expression through a cAMP regulatory element, *Cell Mol Life Sci* 61:1114, 2004.
385. **Norwitz ER, Starkey PM, López Bernal A**, Prostaglandin D2 production by term human decidua: cellular origins defined using flow cytometry, *Obstet Gynecol* 80(3 Pt 1):440, 1992.
386. **Casey ML, MacDonald PC**, Biomolecular processes in the initiation of parturition: decidual activation, *Clin Obstet Gynecol* 31(3):533, 1988.
387. **Gibb W**, The role of prostaglandins in human parturition, *Ann Med* 30(3):235, 1998.
388. **Jaschevatzky OE, Shalit A, Grunstein S, Kaplanski J, Danon A**, Increased decidual prostaglandin E concentration in human abortion, *Br J Obstet Gynaecol* 90(10):958, 1983.
389. **Mortimer G, Hunter IC, Stimson WH, Govan ADT**, A role for amniotic epithelium in control of human

parturition, *Lancet* 1:1074, 1985.

390. **Bennett PR, Rose MP, Myatt L, Elder MG**, Preterm labor: stimulation of arachidonic acid metabolism in human amnion cells by bacterial productions, *Am J Obstet Gynecol* 156:649, 1987.
391. **Romero R, Avila C, Brekus CA, Morotti R**, The role of systemic and intrauterine infection in preterm parturition, *Ann N Y Acad Sci* 622:355, 1991.
392. **Silver RM, Edwin SS, Trautman MS, Simmons DL, Branch DW, Dudley DJ, Mitchell MD**, Bacterial lipopolysaccharide-mediated fetal death. Production of a newly recognized form of inducible cyclooxygenase (COX-2) in murine decidua in response to lipopolysaccharide, *J Clin Invest* 95:725, 1995.
393. **Giannoulis D, Haluska GJ, Gravett MG, Sadowsky DW, Challis JRG, Novy MJ**, Localization of prostaglandin H synthase, prostaglandin dehydrogenase, corticotropin releasing hormone and glucocorticoid receptor in rhesus monkey fetal membranes with labor and in the presence of infection, *Placenta* 26:289, 2005.
394. **Morris C, Khan H, Sullivan MHF, Elder MG**, Effects of platelet-activating factor on prostaglandin E2 production by intact fetal membranes, *Am J Obstet Gynecol* 166:1228, 1992.
395. **Tahara M, Tasaka K, Masumoto N, Adachi K, Adachi H, Ikebuchi Y, Kurachi H, Miyake A**, Expression of messenger ribonucleic acid for epidermal growth factor (EGF), transforming growth factor-alpha (TGF alpha), and EGF receptor in human amnion cells: possible role of TGF alpha in prostaglandin E2 synthesis and cell proliferation, *J Clin Endocrinol Metab* 80:138, 1995.
396. **Lundin-Schiller S, Mitchell MD**, Renin increases human amnion cell prostaglandin E2 biosynthesis, *J Clin Endocrinol Metab* 73:436, 1991.
397. **Mitchell MD**, The regulation of decidual prostaglandin biosynthesis by growth factors, phorbol esters, and calcium, *Biol Reprod* 44:871, 1991.
398. **Schrey MP, Monaghan H, Holt JR**, Interaction of paracrine factors during labour: interleukin-1 $\beta$  causes amplification of decidual cell prostaglandin F2 $\alpha$  production in response to bradykinin and epidermal growth factor, *Prostaglandins Leukot Essent Fatty Acids* 45:137, 1992.
399. **Giannopoulos G, Jackson K, Kredentser J, Tulchinsky D**, Prostaglandin E2 and F2 $\alpha$  receptors in human myometrium during the menstrual cycle and in pregnancy and labor, *Am J Obstet Gynecol* 153:904, 1985.
400. **Shellhaas CS, Coffman T, Dargie PJ, Killam AP, Kay HH**, Intrauterine eicosanoid compartmentalization and regulation of placental blood flow, *J Soc Gynecol Investig* 4:58, 1997.
401. **Giannoulis D, Alfaidy N, Holloway AC, Gibb W, Sun M, Lye SJ, Challis JRG**, Expression of prostaglandin I2 synthase, but not prostaglandin E synthase, changes in myometrium of women at term pregnancy, *J Clin Endocrinol Metab* 87:5274, 2002.
402. **Okazaki T, Casey ML, Okita JR, MacDonald PC, Johnston JM**, Initiation of human parturition: XII. Biosynthesis and metabolism of prostaglandins in human fetal membranes and uterine decidua vera, *Am J Obstet Gynecol* 139:373, 1981.
403. **Gibb W, Sun M**, Localization of prostaglandin H synthase type 2 protein and mRNA in term human fetal membranes and decidua, *J Endocrinol* 150:497, 1996.
404. **Sun M, Ramirez M, Challis JR, Gibb W**, Immunohistochemical localization of the glucocorticoid receptor in human fetal membranes and decidua at term and preterm delivery, *J Endocrinol* 149:243, 1996.
405. **Nakla S, Skinner K, Mitchell BF, Challis JRG**, Changes in prostaglandin transfer across human fetal membranes obtained after spontaneous labor, *Am J Obstet Gynecol* 155:1337, 1986.
406. **Niesert S, Christopherson W, Korte K, Mitchell MD, MacDonald PC, Casey ML**, Prostaglandin E2 9-ketoreductase activity in human decidua vera tissue, *Am J Obstet Gynecol* 155:1348, 1986.
407. **Mitchell BF, Rogers K, Wong S**, The dynamics of prostaglandin metabolism in human fetal membranes and decidua around the time of parturition, *J Clin Endocrinol Metab* 77:759, 1993.
408. **Sangha RK, Walton JC, Ensor CM, Tai H-H, Challis JRG**, Immunohistochemical localization, messenger ribonucleic acid abundance, and activity of 15-hydroxyprostaglandin dehydrogenase in placenta and fetal membranes during term and preterm labor, *J Clin Endocrinol Metab* 78:982, 1994.
409. **van Meir CA, Matthews SG, Keirse MJNC, Ramirez MM, Bocking A, Challis JRG**, 15-Hydroxyprostaglandin dehydrogenase: implications in preterm labor with and without ascending infection, *J Clin Endocrinol Metab* 82:969, 1997.

410. **Giannoulis D, Patel FA, Holloway AC, Lye SJ, Tai HH, Challis JRG**, Differential changes in 15-hydroxyprostaglandin dehydrogenase and prostaglandin H synthase (types I and II) in human pregnant myometrium, *J Clin Endocrinol Metab* 87:1345, 2002.
411. **Patel FA, Clifton VL, Chwalisz K, Challis JR**, Steroid regulation of prostaglandin dehydrogenase activity and expression in human term placenta and chorio-decidua in relation to labor, *J Clin Endocrinol Metab* 84:291, 1999.
412. **Patel FA, Challis JRG**, Cortisol/progesterone antagonism in regulation of 15-hydroxysteroid dehydrogenase activity and mRNA levels in human chorion and placental trophoblast cells at term, *J Clin Endocrinol Metab* 87:700, 2002.
413. **Casciani V, Premyslova M, Luo D, Marinoni E, Moscrini M, Di Iorio R, Challis JRG**, Effect of calcium ionophore A23187 on prostaglandin synthase type 2 and 15-hydroxy-prostaglandin dehydrogenase expression in human chorion trophoblast cells, *Am J Obstet Gynecol* 199:554.e1, 2008.
414. **Weiss A, Goldman S, Shalev E**, the matrix metalloproteinases (MMPS) in the decidua and fetal membranes, *Front Biosci* 12:649, 2007.
415. **Xu P, Alfaidy N, Challis JRG**, Expression of matrix metalloproteinase (MMP-2) and MMP-9 in human placenta and fetal membranes in relation to preterm and term labor, *J Clin Endocrinol Metab* 87:1353, 2002.
416. **Norwitz ER, Snegovskikh V, Schatz F, Foyouzi N, Rahman M, Buchwalder L, Lee HJ, Funai EF, Buhimschi CS, Buhimschi IA, Lockwood CJ**, Progesterone inhibits and thrombin stimulates the plasminogen activator-inhibitor system in term decidual stromal cells: implications for parturition, *Am J Obstet Gynecol* 196:382.e1, 2007.
417. **Hirst JJ, Chibbar R, Mitchell BF**, Role of oxytocin in the regulation of uterine activity during pregnancy and in the initiation of labor, *Semin Reprod Med* 11:219, 1993.
418. **Hirst JJ, Haluska GJ, Cook MJ, Novy MJ**, Plasma oxytocin and nocturnal uterine activity: maternal but not fetal concentrations increase progressively during late pregnancy and delivery in Rhesus monkeys, *Am J Obstet Gynecol* 169:415, 1993.
419. **Russell JA, Leng G, Douglas AJ**, The magnocellular oxytocin system, the fount of maternity: adaptations in pregnancy, *Front Neuroendocrinol* 24:27, 2003.
420. **Wilson T, Liggins GC, Whittaker DJ**, Oxytocin stimulates the release of arachidonic acid and prostaglandin F<sub>2α</sub> from human decidual cells, *Prostaglandins* 35:771, 1988.
421. **Chibbar R, Miller FD, Mitchell BF**, Synthesis of oxytocin in amnion, chorion, and decidua may influence the timing of human parturition, *J Clin Invest* 91:185, 1993.
422. **Chibbar R, Wong S, Miller FD, Mitchell BF**, Estrogens stimulate oxytocin gene expression in human chorio-decidua, *J Clin Endocrinol Metab* 80:567, 1995.
423. **Zeeman GG, Khan-Dawood FS, Dawood MY**, Oxytocin and its receptor in pregnancy and parturition: current concepts and clinical implications, *Obstet Gynecol* 89:873, 1997.
424. **Burghardt RC, Barhoumi R, Dookwah H**, Endocrine regulation of myometrial gap junctions and their role in parturition, *Semin Reprod Med* 11:250, 1993.
425. **Carsten ME, Miller JD**, A new look at uterine muscle contraction, *Am J Obstet Gynecol* 157:1303, 1987.
426. **Sanborn BM**, Hormonal signaling and signal pathway crosstalk in the control of myometrial calcium dynamics, *Semin Cell Dev Biol* 18:305, 2007.
427. **Seron-Ferre M, Ducsay CA, Valenzuela GJ**, Circadian rhythms during pregnancy, *Endocr Rev* 14:594, 1993.
428. **Chan EC, Fraser S, Yeo YS, Kwek K, Fairclough RJ, Smith R**, Human myometrial genes are differentially expressed in labor: a suppression subtractive hybridization study, *J Clin Endocrinol Metab* 87:2435, 2002.
429. **Van den Veyver IB, Moise KJ Jr**, Prostaglandin synthetase inhibitors in pregnancy, *Obstet Gynecol Surv* 48:493, 1993.
430. **Sorensen TK, Easterling TR, Carlson KL, Brateng DA, Benedetti TJ**, The maternal hemodynamic effect of indomethacin in normal pregnancy, *Obstet Gynecol* 79:661, 1992.
431. **Carlan SJ, O'Brien WF, O'Leary TD, Mastrogiannis D**, Randomized comparative trial of indomethacin and sulindac for the treatment of refractory preterm labor, *Obstet Gynecol* 79:223, 1992.

432. **Rasanen J, Jouppila P**, Fetal cardiac function and ductus arteriosus during indomethacin and sulindac therapy for threatened preterm labor: a randomized study, *Am J Obstet Gynecol* 173:20, 1995.
433. **Stika CS, Gross GA, Leguizamon G, Gerber S, Levy R, Mathur A, Bernhard LM, Nelson DM, Sadovsky Y**, A prospective randomized safety trial of celecoxib for treatment of preterm labor, *Am J Obstet Gynecol* 187:653, 2002.
434. **Borna S, Saeidi FM**, Celecoxib versus magnesium sulfate to arrest preterm labor: randomized trial, *J Obstet Gynaecol Res* 33:631, 2007.
435. **Cabrol D, Landesman R, Muller J, Uzan M, Sureau C, Saxena BB**, Treatment of polyhydramnios with prostaglandin synthetase inhibitor (indomethacin), *Am J Obstet Gynecol* 157:422, 1987.
436. **Cabrol D, Jannet D, Pannier E**, Treatment of symptomatic polyhydramnios with indomethacin, *Eur J Obstet Gynecol Reprod Biol* 66:11, 1996.
437. **Abhyankar S, Salvi VS**, Indomethacin therapy in hydramnios, *J Postgrad Med* 46:176, 2000.
438. **Sanchez-Ramos L, Kaunitz AM, Wears RL, Delke I, Gaudier FL**, Misoprostol for cervical ripening and labor induction: a meta-analysis, *Obstet Gynecol* 89:633, 1997.
439. **Barrilleaux PS, Bofill JA, Terrone DA, Magann EF, May WL, Morrison JC**, Cervical ripening and induction of labor with misoprostol, dinoprostone gel, and a Foley catheter: a randomized trial of 3 techniques, *Am J Obstet Gynecol* 186:1124, 2002.
440. **Hofmeyr GJ, Gülmezoglu AM**, Vaginal misoprostol for cervical ripening and induction of labor, *Cochrane Database Syst Rev* (1):CD00941, 2003. doi:10.1002/14651858.
441. **Alfirevic Z, Weeks A**, Oral misoprostol for induction of labour, *Cochrane Database Syst Rev* (2):CD001338, 2006. doi:10.1002/14651858.
442. **Ray DA, Garite TJ**, Prostaglandin E2 for induction of labor in patients with premature rupture of membranes at term, *Am J Obstet Gynecol* 166:836, 1992.
443. **Sanchez-Ramos L, Kaunitz AM, Del Valle GO, Delke I, Schroeder PA, Briones DK**, Labor induction with the prostaglandin E1 methyl analogue misoprostol versus oxytocin: a randomized trial, *Obstet Gynecol* 81:332, 1993.
444. **Wing DA, Lovett K, Paul RH**, Disruption of prior uterine incision following misoprostol for labor induction in women with previous cesarean delivery, *Obstet Gynecol* 91:828, 1998.
445. **Sanchez-Ramos L, Chen A, Kaunitz AM, Gaudier FL, Delke I**, Labor induction with intravaginal misoprostol in term premature rupture of membranes: a randomized study, *Obstet Gynecol* 89:909, 1997.
446. **Peyron R, Aubeny E, Targosz V, Silvestre L, Renault M, Elkik F, Leclerc P, Ulmann A, Baulieu EE**, Early termination of pregnancy with mifepristone (RU 486) and the orally active prostaglandin misoprostol, *N Engl J Med* 328:1509, 1993.
447. **El-Rafaey HJ, Rajasekar D, Abdalla M, Calder L, Templeton A**, Induction of abortion with mifepristone (RU 486) and oral or vaginal misoprostol, *N Engl J Med* 332:983, 1995.
448. **Webster D, Penney GC, Templeton A**, A comparison of 600 and 200 mg mifepristone prior to second trimester abortion with the prostaglandin misoprostol, *Br J Obstet Gynaecol* 103:706, 1996.
449. **Esteve JL, Gallego FG, Llorente MP, Bermúdez SB, Sala ES, Gopnzález LV, Texidó CS**, Late second-trimester abortions induced with mifepristone, misoprostol and oxytocin: a report of 428 consecutive cases, *Contraception* 78:52, 2008.
450. **O'Leary JA**, Prostaglandins and postpartum hemorrhage, *Semin Reprod Endocrinol* 3:247, 1985.
451. **Gülmezoglu AM, Fornà F, Villar J, Hofmeyr GJ**, Prostaglandins for preventing postpartum haemorrhage, *Cochrane Database Syst Rev* (3):CD000494, 2002.
452. **Alfirevic Z, Blum J, Walraven G, Weeks A, Winikoff B**, Prevention of postpartum hemorrhage with misoprostol, *Int J Gynecol Obstet* 99:S198, 2007.
453. **Coceani F, Olley PM, Lock JE**, Prostaglandins, ductus arteriosus, pulmonary circulation: current concepts and clinical potential, *Eur J Clin Pharmacol* 18:75, 1980.
454. **Brodlie M, Chaudhari M, Hasan A**, Prostaglandin therapy for ductal patency: how long is too long? *Acta Paediatr* 97:1303, 2008.
455. **Görk AS, Ehrenkranz RA, Bracken MB**, Continuous infusion versus intermittent bolus doses of

- indomethacin for patent ductus arteriosus closure in symptomatic preterm infants, *Cochrane Database Syst Rev* (1):CD006071, 2008.
456. **Ohlsson A, Walia R, Shah S**, Ibuprofen for the treatment of patent ductus arteriosus in preterm and/or low birth weight infants, *Cochrane Database Syst Rev* (1):CD003481, 2008.
  457. **Brash AR, Hickey DE, Graham TP, Stahlman MT, Oates JA, Cotton RB**, Pharmacokinetics of indomethacin in the neonate: relation of plasma indomethacin levels to response of the ductus arteriosus, *N Engl J Med* 305:67, 1981.
  458. **Rudolph AM**, The effects of nonsteroidal antiinflammatory compounds on fetal circulation and pulmonary function, *Obstet Gynecol* 58:635, 1981.
  459. **Vermillion ST, Scardo JA, Lashus AG, Wiles HB**, The effect of indomethacin tocolysis on fetal ductus arteriosus constriction with advancing gestational age, *Am J Obstet Gynecol* 177:256, 1997.
  460. **Thorburn GD**, The placenta, PGE2 and parturition, *Early Hum Dev* 29:63, 1992.
  461. **Gluck L, Kulovich MV, Borer RC, Brenner PH, Anderson GG, Spellacy WN**, Diagnosis of respiratory distress syndrome by amniocentesis, *Am J Obstet Gynecol* 109:440, 1971.
  462. **St Clair C, Norwitz ER, Woensdregt K, Cackovic M, Shaw JA, Malkus H, Ehrenkranz RA, Illuzzi JL**, The probability of neonatal respiratory distress syndrome as a function of gestational age and lecithin/sphingomyelin ratio, *Am J Perinatol* 25:473, 2008.
  463. **Liggins GC**, Premature delivery of foetal lambs infused with glucocorticoids, *J Endocrinol* 45:515, 1969.
  464. **Mendelson CR, Boggaram V**, Hormonal control of the surfactant system in the fetal lung, *Annu Rev Physiol* 53:415, 1991.
  465. **Dekowski SA, Snyder JM**, Insulin regulation of messenger ribonucleic acid for the surfactant-associated proteins in human fetal lung in vitro, *Endocrinology* 131:669, 1992.
  466. **Committee on Obstetric Practice**, Committee Opinion No. 713. Antenatal corticosteroid therapy for fetal maturation, *Obstet Gynecol* 130:e102, 2017.
  467. **Carlo WA, McDonald SA, Fanaroff AA, Vohr BR, Stoll BJ, Ehrenkranz RA, et al.; Eunice Kennedy Shriver National Institute of Child Health and Human Development Neonatal Research Network**, Association of antenatal corticosteroids with mortality and neurodevelopmental outcomes among infants born at 22 to 25 weeks' gestation, *JAMA* 306:2348, 2011.
  468. **Ballard RA, Ballard PL, Creasy RK, Padbury J, Polk DH, Bracken M, Moya FR, Gross I, and the TRH Study Group**, Respiratory disease in very-low-birthweight infants after prenatal thyrotropin-releasing hormone and glucocorticoids, *Lancet* 339:510, 1992.
  469. **ACTOBAT Study Group**, Australian collaborative trial of antenatal thyrotropin-releasing hormone (ACTOBAT) for prevention of neonatal respiratory disease, *Lancet* 345:877, 1995.
  470. **Crowther CA, Alfirevic Z, Haslam RR**, Thyrotropin-releasing hormone added to corticosteroids for women at risk of preterm birth for preventing neonatal respiratory disease, *Cochrane Database Syst Rev* (2):CD000019, 2004.
  471. **Wisner KL, Stowe ZN**, Psychobiology of postpartum mood disorders, *Semin Reprod Endocrinol* 15:77, 1997.
  472. **Magiakou M-A, Mastorakos G, Rabin D, Dubbert B, Gold PW, Chrousos GP**, Hypothalamic corticotropin-releasing hormone suppression during the postpartum period: implications for the increase in psychiatric manifestations at this time, *J Clin Endocrinol Metab* 81:1912, 1996.

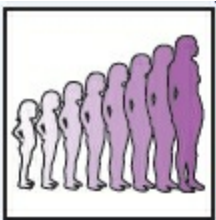


# CLINICAL ENDOCRINOLOGY

---



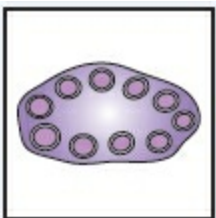
**Chapter 8:** Normal and Abnormal Sexual Development



**Chapter 9:** Normal and Abnormal Growth and Pubertal Development



**Chapter 10:** Amenorrhea



**Chapter 11:** Chronic Anovulation and the Polycystic Ovary Syndrome



**Chapter 12:** Hirsutism



### **Chapter 13: Reproduction and the Adrenal**



### **Chapter 14: Menstruation-Related Disorders**



### **Chapter 15: Abnormal Uterine Bleeding**



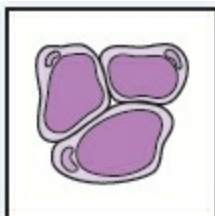
### **Chapter 16: The Breast**



### **Chapter 17: Menopause Transition and Menopause Hormone Therapy**



### **Chapter 18: Transgender Endocrinology**



### **Chapter 19: Obesity**



## **Chapter 20: Reproduction and the Thyroid**

---

# Normal and Abnormal Sexual Development

Abnormalities of sexual differentiation are seen infrequently in an individual clinician's practice. However, few physicians have not been challenged at least once by a newborn with ambiguous genitalia or by a young woman with primary amenorrhea. Traditional classifications for disorders of sexual differentiation have been confusing, but advances in reproductive science have helped to define their causes and to provide the foundation for a logical and efficient approach to diagnosis.

This chapter first considers the processes involved in normal sexual differentiation, to provide a basis for understanding the various types and causes of abnormal development. Some subjects are discussed in other chapters, but also are included here, for clarity and completeness. The fundamental theme is that disorders of sexual development (DSD) result primarily from abnormalities in the amount or action of androgens—from excess androgen in females and from too little androgen in males.

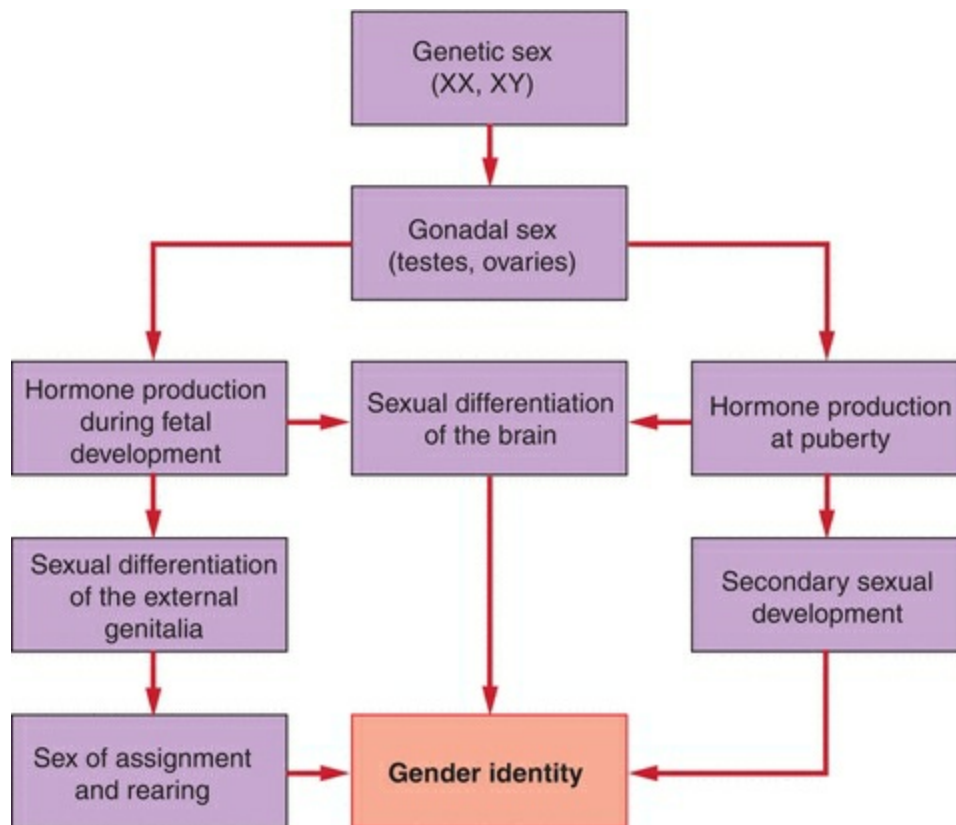
# NORMAL SEXUAL DIFFERENTIATION

---

The gender identity of a person (whether an individual identifies as a male or a female) is determined by their genetic, gonadal, and phenotypic sex and also is influenced by their environment. Genetic or chromosomal sex is defined by the sex chromosomes, typically XX or XY. Gonadal sex is defined by the direction of gonadal differentiation, into ovaries or testes. Phenotypic sex is defined primarily by the appearance of the external genitalia and the secondary sexual characteristics that develop at puberty. Gender identity includes all behavior having any sexual connotation, such as body gestures and mannerisms, habits of speech, recreational preferences, and content of dreams. Sexual expression, both homosexual and heterosexual, reflects the sum of all sexual influences on the individual, both prenatal and postnatal, the latter referring to the role assigned by society in accordance with the individual's phenotype and behavior.

Normal sexual differentiation involves a sequence of related processes that begins with genetic or chromosomal sex, as established at the time of fertilization.<sup>1</sup> Gonadal sex is determined next; directed by the genetic sex, the indifferent gonads differentiate into ovaries or testes. In turn, gonadal sex controls the hormonal environment of the embryo, which directs the development of the internal and external genitalia. The processes involved in sexual differentiation of the embryonic brain are less clear, but may involve mechanisms similar to those controlling differentiation of the external genitalia. The inductive influences of hormones on the developing central nervous system (CNS) ultimately may determine the patterns of hormone secretion and sexual behavior in the adult.<sup>2,3,4,5,6,7</sup>

Although the mechanisms that govern sex differentiation are not yet entirely clear, our understanding of the molecular processes involved has advanced significantly in recent years. Current concepts are summarized here, beginning with the genetics of sex determination, followed by germ cell sex differentiation, gonadal differentiation, and development of the internal and external genitalia (**Figure 8.1**).



**FIGURE 8.1**

# Genetics of Sex Determination

Both the X and the Y chromosomes appear to have evolved from autosomal ancestors over a period of 300 million years.<sup>8</sup> Most of the ancestral genes on the Y chromosome have been lost in the process, leaving only a limited number of currently active genes. A great many genes are involved in translating the sex chromosome composition of the embryo and in directing the differentiation of the gonadal somatic cells,<sup>9,10,11</sup> but sex determination depends primarily on the presence or absence of a Y chromosome.

In females, the identical pair of X chromosomes aligns and recombines along its entire length during meiosis, like the autosomes. In males, homology between the X and Y chromosomes is limited to two small regions located at the very distal ends of the short and long arms of the Y. The “pseudoautosomal” region constitutes only approximately 5% of the entire Y chromosome and is the only region that normally pairs and recombines during meiosis.<sup>10,12</sup> Most of the remaining 95% of the Y chromosome is unique to the male, containing multiple copies of genes expressed specifically in the testis and encoding proteins with specialized functions.<sup>8</sup> A single copy of the one gene most critical to testis differentiation, SRY (Sex-determining Region on Y), is located on the distal short arm of the Y (Yp11.3), immediately adjacent to the pseudoautosomal region.<sup>13</sup>

Most of what is known about the genetic basis for sexual differentiation derives from studies of mutations in the mouse and human associated with varying degrees of “sex reversal,” conditions in which the chromosomal sex does not correlate with the gonadal or phenotypic sex. **In humans, 46,XX male sex reversal occurs when pairing between the X and Y chromosomes during male meiosis extends abnormally into adjacent nonhomologous regions, allowing inappropriate recombination and transfer of Y-specific DNA onto the X chromosome.** Careful analysis of four XX males having a very small piece of translocated Y DNA (60 kb)<sup>14</sup> prompted a search for highly conserved sequences within that region, which led to discovery of the SRY gene.<sup>13</sup> The identification of SRY mutations in three XY females supported the hypothesis that SRY was the critical and long-sought “testis-determining factor,”<sup>15,16</sup> but proof derived ultimately from studies in the mouse. First, a deletion in Sry (by convention, mouse gene symbols are italicized and the first letter is in uppercase with all the rest in lowercase, human gene symbols are italicized and all letters are in uppercase, mouse and human protein designations are the same as the gene symbol, but not italicized and all in uppercase) was identified in a line of XY female mice.<sup>17</sup> Second, Sry gene expression in the genital ridge was observed just at the time of testis differentiation.<sup>18</sup> Third, transgenic XX mice carrying Sry develop as males.<sup>19</sup> **SRY now is generally established as the primary genetic signal determining the direction of**

**gonadal differentiation in mammals.**<sup>10,20</sup> However, XX hermaphrodites having ovotestes but not SRY have been described, and only a small proportion of phenotypic females with XY gonadal dysgenesis (Swyer syndrome) harbor SRY mutations. These observations indicate clearly that sex determination and sex reversal involve genes other than SRY.<sup>21</sup>

Although the mechanisms that regulate SRY expression are still unclear, the nuclear receptor SF1 (Steroidogenic Factor 1) has emerged as a likely and important activator. In the mouse, SF1 binds to and activates the Sry promoter,<sup>22</sup> and heterozygous mutations in the Sfl gene (resulting in haploinsufficiency) produce XY female sex reversal.<sup>23,24,25</sup> In humans, SF1 haploinsufficiency is a known cause of XY female sex reversal,<sup>26</sup> and an SF1 polymorphism that reduces transactivation function by approximately 20% is recognized as a susceptibility factor for the development of micropenis and cryptorchidism.<sup>27,28</sup> Evidence indicates that splice variants of WT1 (Wilms tumor 1) and GATA4 (GATA-binding protein 4) also may be involved in the regulation of Sry expression; both are transcription factors containing zinc-finger motifs that can interact and synergistically activate the promoter of human SRY.<sup>29</sup> WT1 mutations are associated with gonadal dysgenesis and ambiguous genitalia in males.<sup>30</sup>

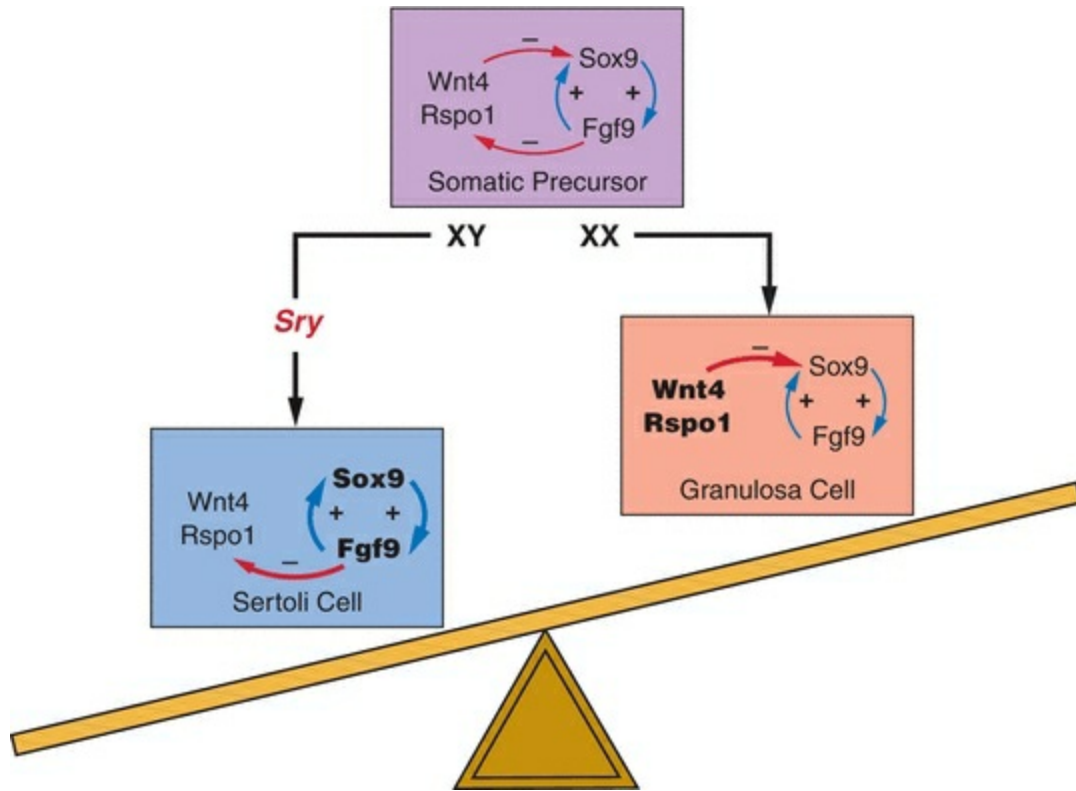
**The sequence of molecular events involved in testis differentiation is not completely understood, but SRY appears to activate a number of other genes that promote testis development.**<sup>31</sup> The 204 amino acid protein product of SRY (SRY) contains a 79 amino acid domain very similar to that in a recognized family of transcription factors known as the high mobility group (HMG), which bind to DNA and regulate gene transcription. Members of the related SRY HMG box (SOX) protein family of transcription factors play a crucial role in the cascade of events that drives testis differentiation, and most of the SRY point mutations identified in sex-reversed patients translate to abnormalities in the amino acid sequence of SOX proteins.<sup>32</sup>

**Substantial evidence now indicates that SOX9 is the most likely SRY target gene.** In mice, Sox9 expression is dramatically up-regulated soon after Sry expression begins in XY gonads but down-regulated in XX gonads,<sup>33</sup> and cell fate mapping experiments have found that SOX9-positive Sertoli cells derive exclusively from SRY-positive gonadal somatic cells.<sup>34</sup> XY mouse embryos having a targeted deletion of Sox9 develop ovaries,<sup>35,36</sup> and transgenic activation of Sox9 expression induces male development in XX embryos.<sup>10</sup> In humans, heterozygous mutations in SOX9 (resulting in haploinsufficiency) cause a skeletal malformation syndrome (campomelic dysplasia) in which most affected XY patients exhibit female sex reversal, and SOX9 duplication (resulting in overexpression) is the only known autosomal cause of XX male sex reversal.<sup>32</sup>



The developmental consequences of activating and inactivating mutations in Sox9 resemble those of similar mutations in Sry, implying not only that Sox9 is required for testis differentiation, but also that Sry activation of Sox9 may be all that is necessary to activate other genes important to testis development, such as Fgf9 (fibroblast growth factor 9), and to repress genes that induce ovary development, such as Wnt4 (a member of the wingless family of genes), Rspo1 (Respondin 1), Dax1 (dosage-sensitive sex reversal, adrenal hypoplasia critical region, on chromosome X, gene 1), and Foxl2 (forkhead box L2).<sup>32</sup> DAX1 is a nuclear transcription factor normally up-regulated in the ovary and repressed by SOX9, but DAX1 duplication (resulting in overexpression) can repress SRY (directly, or indirectly by inhibiting SF1) and cause XY female sex reversal.<sup>37,38</sup> SOX9 probably is the one most important factor regulating the activity of genes involved in Sertoli cell differentiation, and evidence suggests that SOX9 drives the process via feed-forward loops that up-regulate its own expression. SOX9 stimulates Sfl expression, binds to the same enhancer as SRY (after Sry expression has ended), and also stimulates Fgf9 expression in nascent Sertoli cells, all of which up-regulate Sox9 expression and combine to maintain high levels of SOX9 activity.<sup>10,31,32</sup> **Although a great many genes are involved in testis differentiation, virtually all male-to-female sex reversal in mice and in humans can be explained ultimately, directly or indirectly, by the failure to generate sufficient levels of SOX9 to promote the positive-feedback loops that maintain its expression.**

FGF9 appears particularly critical for maintaining the levels of Sox9 expression required to induce testis differentiation. Both Fgf9 and Sox9 are expressed at low levels in bipotential XX and XY gonads (**Figure 8.2**), but Fgf9 expression is lost in XX and amplified in XY gonads soon after Sry is expressed.<sup>39</sup> Deletion of Fgf9 does not prevent initial expression of Sry or Sox9 in Sertoli cell precursors, but Sox9 expression is a prerequisite for Fgf9 expression, and without it, Sox9 expression cannot be sustained.<sup>40</sup> FGF9 also appears to actively repress genes that promote ovary differentiation, such as Wnt4.<sup>39</sup>



**FIGURE 8.2**

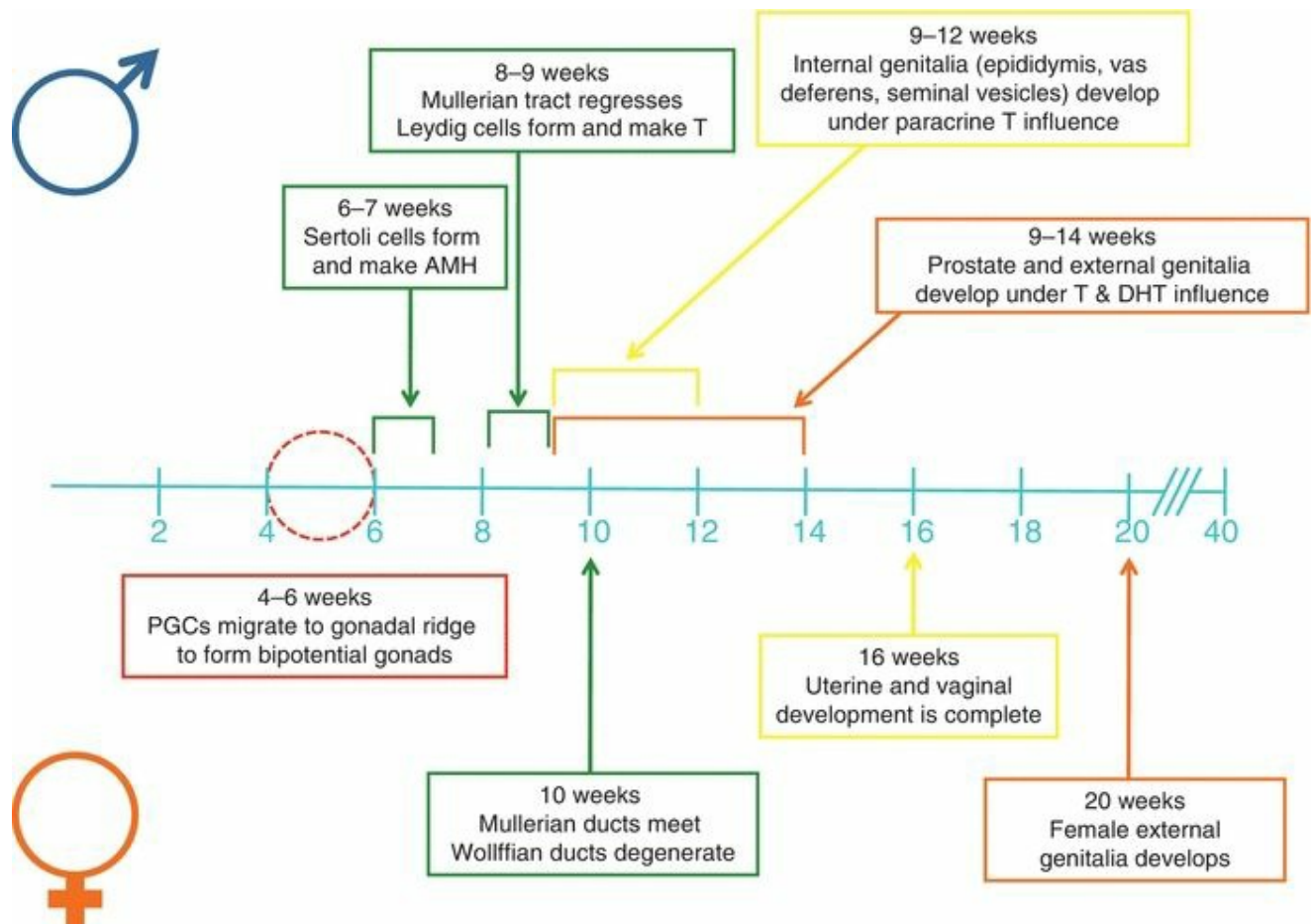
Whereas ovarian differentiation has long been considered the “default” pathway of sex determination—the automatic result in the absence of a testis-determining factor—recent evidence challenges that traditional concept. In mice, inactivating mutations in genes such as *Wnt4*,<sup>39,41</sup> *Rspo1*,<sup>42,43,44</sup> and *Foxl2*<sup>45,46,47</sup> result in partial or complete XX male sex reversal, and activating mutations in  $\beta$ -catenin or *Dax1* result in XY female sex reversal.<sup>32,48,49</sup> *Rspo1* is required for *Wnt4* expression and activates  $\beta$ -catenin, which, like *Foxl2*, down-regulates *Sox9* expression.<sup>21</sup> *Dax1* acts as a dominant-negative regulator of transcription of other nuclear receptors, including SF1, and thus may repress *Sry* expression.<sup>32</sup> Taken together, these observations suggest strongly that ovarian development results from the active repression of one or more genes in the testis pathway, rather than from a developmental default mechanism.

**It now appears that both testis and ovary differentiation require dominantly acting genes, with SRY inducing testis development via up-regulation of SOX9 and with other genes, primarily WNT4 and RSP01, teaming to promote ovary development via repression of SOX9. The new concept views the fate of the bipotential gonad as balanced between opposing forces and SRY as the key factor. In XY gonads, SRY induces SOX9 and tips differentiation toward testis development, and in XX gonads lacking SRY, other genes combine to repress SOX9**

**and promote ovary development.**<sup>21,50</sup>

# Germ Cell Sex Differentiation

In human embryos, gonadal development begins during the 5th week of gestation as a protuberance overlying the mesonephric ducts, known as the genital or gonadal ridge. The primordial germ cells do not arise within but migrate into the developing gonads between 4 and 6 weeks of gestation, proliferating as they go (**Figure 8.3**). At least in the mouse, their survival during migration appears to depend on an interaction between the cell surface tyrosine kinase receptor, c-KIT, and a ligand produced by surrounding tissues, called stem cell factor.<sup>51</sup> At this stage of development, the gonads are identical in males and females, indifferent and bipotential, capable of differentiating into either testes or ovaries in response to inductive signals. Although germ cells do not induce gonadal development, they play a more active role in females than in males. In the genetic or pharmacologically induced absence of germ cells, testis cords (the embryonic precursor to seminiferous tubules in the adult testis) can develop, but in females, ovary differentiation fails altogether<sup>52,53</sup>; somatic cells aggregate but deteriorate, leaving only stromal tissue and, ultimately, a fibrous streak. **After arrival in the nascent gonads, germ cell differentiation into male (prospermatogonia) or female (oogonia) depends on the sex of the gonadal somatic cells and on signals in the surrounding environment rather than on the chromosomal sex of the germ cells themselves.** In XY/XX mouse chimeras, XY primordial germ cells can develop as oogonia in female embryos, and XX germ cells as prospermatogonia in male embryos.<sup>54</sup>



**FIGURE 8.3**

It is not yet clear whether the signaling molecules that mediate germ cell sex determination act in the developing testis to inhibit meiosis or in the developing ovary to induce meiosis, what those signaling molecules may be, and whether they act directly on the germ cells themselves or indirectly via actions on gonadal somatic cells.<sup>31</sup> Recent studies in mice aimed at identifying molecular candidates for the putative meiosis-inducing or meiosis-inhibiting factors have focused attention on retinoic acid, which is produced in the mesonephros. Whereas retinoic acid treatment induces primordial germ cells in male gonadal explant cultures to express *Stra8*, *Scp3*, and *Dmc1* (meiosis marker genes), germ cells in female gonadal explants treated with a retinoic acid inhibitor continue to express *Oct4* (a marker for pluripotent cells).<sup>55</sup> Moreover, Sertoli cells, which surround the germ cells in the developing testis cords, express *Cyp26B1*, a gene encoding an enzyme (CYP26B1) that metabolizes retinoic acid.<sup>56</sup> **Taken together, these observations suggest that local levels of retinoic acid may regulate germ cell differentiation in the developing gonad, with retinoic acid diffusing from the adjacent mesonephros acting as the functional meiosis-inducing factor in female germ cells and with CYP26B1 produced by Sertoli cells in the**

**developing testis cords acting as the functional meiosis-inhibiting factor in male germ cells.**<sup>10</sup> Alternatively, or in addition, Sertoli cells may secrete a specific meiosis-inhibiting factor, with one likely downstream target being Nanos2, a gene expressed exclusively in male germ cells.<sup>31,57</sup>

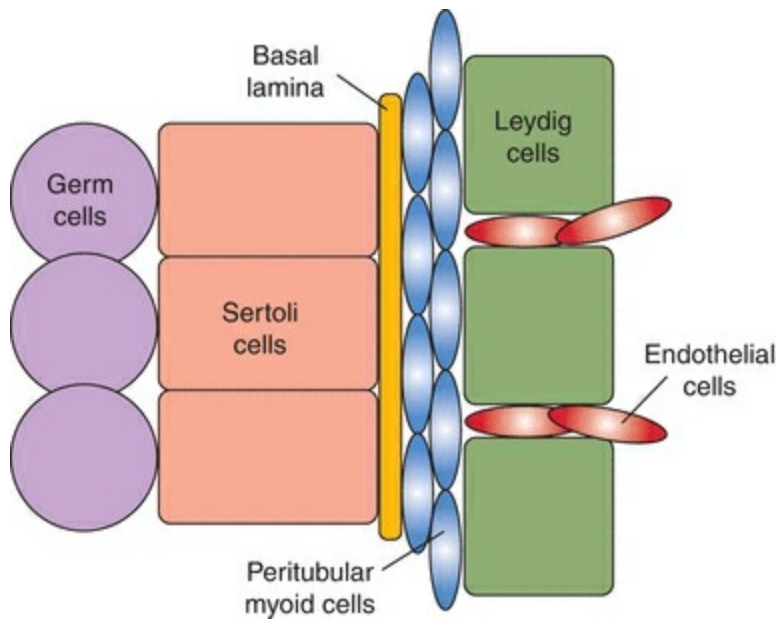
In the male, the primordial germ cells become incorporated into the developing testis cords and enter mitotic arrest as prospermatogonia, resuming proliferation soon after birth. In the female, the primordial germ cells (oogonia) continue to proliferate by mitosis somewhat longer, reaching a peak of 5–7 million by 20 weeks of gestation. However, only some enter meiosis and become primary oocytes, arresting in diplotene of the first meiotic prophase, and become surrounded by a single layer of flattened pregranulosa cells, forming primordial follicles. Those that are not incorporated into primordial follicles degenerate via apoptosis, and, by birth, only approximately 1–2 million germ cells remain. The signals for programmed cell death are unknown but seem likely to involve some form of intercellular communication between the primary oocyte and surrounding pregranulosa cells.

Whereas male germ cells proliferate continuously, the traditional dogma has held that female germ cells proliferate only during embryogenesis and, therefore, that females are born with a finite number of primordial follicles that are steadily depleted and cannot be replenished. However, that dogma has been challenged by studies suggesting that germ-line stem cells reside within the bone marrow and may replenish the ovary with new oocytes,<sup>58,59</sup> stimulating a vigorous scientific debate,<sup>60,61,62,63,64,65,66</sup> which continues.<sup>67,68,69</sup>

# Testis Differentiation and Development

The current model for testis differentiation and development, based primarily on studies in mice, envisions a sequence of events that begins with the formation of the genital ridge, first recognized as a thickening underlying the coelomic epithelium adjacent to the mesonephros. Primordial germ cells migrate into the genital ridge, along with proliferating coelomic epithelial cells, which express SF1. A portion of the epithelial daughter cells expresses Sry to become Sertoli cell precursors, the first cell type to differentiate and the only cell type in the developing testis that expresses Sry. The subset of somatic cells expressing Sry immediately also begins to express Sox9, a reliable marker for developing Sertoli cells. In turn, Sox9-positive Sertoli cell precursors secrete other paracrine signaling molecules such as Fgf9 and prostaglandin D<sub>2</sub> (PGD<sub>2</sub>), which also play important roles in testis differentiation. FGF9 reinforces Sox9 expression and induces neighboring cells to proliferate, thereby increasing the generation of supporting cell precursors that are able to express Sry. PGD<sub>2</sub> can induce even Sry-negative cells to express SOX9 and to differentiate into Sertoli cells.<sup>34</sup> Together, FGF9 and PGD<sub>2</sub> help to maintain SOX9 levels and to ensure a sufficient number of Sertoli cells to form a testis. Once the number of SOX9-positive cells reaches a critical threshold, SOX9 represses Sry expression.

Under the control of Sry, Sertoli cells also secrete a factor that induces a migration of cells from the adjacent mesonephros. The developing testis enlarges rapidly with the influx of migrating cells, which differentiate into endothelial cells and Leydig cells upon their arrival in the developing gonad.<sup>10</sup> Male-specific peritubular myoid cells appear to differentiate from cells already within the gonad, flattening and surrounding aggregates of Sertoli cells that organize in layers around clusters of primordial germ cells.<sup>50</sup> The peritubular myoid cells thus help to form the testis cords, later serving to promote the movement of sperms through the seminiferous tubules in the adult testis. Together, the Sertoli cells and peritubular myoid cells induce the development of a basal lamina between them, separating the testis cords from the interstitial tissue. The steroidogenic Leydig cells differentiate within the interstitium, in close proximity to developing blood vessels that derive from endothelial cell precursors. Endothelial cell migration from the mesonephros is specific to the male and required for development of an arterial network that extends throughout the interstitium but not into the testis cords<sup>50</sup> (**Figure 8.4**).



**FIGURE 8.4**



# Ovary Differentiation and Development

In females lacking a Y chromosome and SRY, the bipotential gonad begins to differentiate into an ovary about 2 weeks later than testis development begins in the male. **Normal ovarian differentiation requires the presence of germ cells; in their absence, the gonadal somatic cells fail to differentiate, indicating some form of communication between germ cells and somatic cells.**<sup>53</sup> Wnt4 and Rspo1 are two genes that play an important role in ovarian differentiation; XX mice with targeted deletions of either gene develop ovotestes containing sex cords and functional Leydig cells.<sup>43</sup> Wnt4 expression suppresses the migration of mesonephric endothelial and steroidogenic cells as occurs in the developing testis. This action of Wnt4 is dependent on Rspo1.<sup>41,43</sup> Rspo1 expression is specifically up-regulated in XX somatic cells from the earliest stages of gonadal differentiation and encodes a secreted protein that, like WNT4, activates the  $\beta$ -catenin signaling pathway in somatic cells, resulting in a loss of cell-cell adhesion between female germ cells, which is a prerequisite for their entry into meiosis.<sup>43</sup> Consequently, directly or indirectly, RSPO1 regulates female germ cell and ovarian differentiation, by promoting events required for initiation of meiosis, by inhibiting migration of mesonephric cells via Wnt4 expression, and by down-regulating Sox9, which drives testis differentiation. **Thus, whereas testis differentiation is directed by somatic cells, ovary differentiation requires communication between somatic cells and germ cells.**<sup>70</sup>

Gradually, the developing ovary becomes organized into an outer cortex and an inner medullary region, which ultimately regresses, leaving behind a compressed nest of vestigial tubules and Leydig cells in the hilar region known as the rete ovarii. By 20 weeks of gestation, the ovary achieves mature compartmentalization, consisting of an active cortex containing follicles exhibiting early stages of maturation and atresia, and a developing stroma. Within the cortex, primordial follicles are separated from the somatic cells by a surrounding basement membrane. In some primordial follicles, the pregranulosa cells become cuboidal and proliferate, the oocyte enlarges and produces a zona pellucida (an extracellular glycoprotein matrix deposited between the oocyte and the granulosa cells), and a surrounding layer of thecal cells develops. The remainder stay quiescent until sometime later.

The molecular events that regulate primordial follicle formation and that stimulate or inhibit the initiation of follicular development are understood poorly but appear to involve a variety of factors, all locally produced and regulated, including members of the transforming growth factor  $\beta$  (TGF- $\beta$ ) superfamily of proteins and another family of trophic factors called neurotrophins. Activins, inhibins, antimüllerian hormone (AMH), and bone morphogenetic proteins (BMPs) are members of the TGF- $\beta$  family of proteins.

Activins promote and inhibins retard primordial follicle development, and their relative local concentrations in the fetal ovary during the time of follicle assembly may determine the size of the ovarian follicular pool.<sup>71</sup> AMH appears to be an important inhibitor of primordial follicle growth, and BMPs exert the opposite effect.<sup>71</sup> AMH action is mediated, at least in part, by the transcription factor Osterix (Osx), which influences regression of müllerian ducts.<sup>72</sup> Neurotrophins and their receptors are essential for the differentiation and survival of various neuronal populations in the central and peripheral nervous systems, but their presence in the developing ovary suggests they also play a role in ovarian development. Four mammalian neurotrophins have been identified, including nerve growth factor (NGF), brain-derived neurotrophic factor (BDNF), neurotrophin-3 (NT-3), and neurotrophin 4/5 (NT-4/5), all of which exert their actions via binding to high-affinity transmembrane tyrosine kinase receptors encoded by members of the trk proto-oncogene family (NGF to TrkA, BDNF and NT-4/5 to TrkB, and NT-3 to TrkC).<sup>73</sup> Observations in NGF- and TrkA-null mice indicate that NGF stimulates the proliferation of ovarian mesenchymal cells during the early stages of follicular assembly and promotes differentiation and synthesis of follicle-stimulating hormone (FSH) receptors in granulosa cells. Similar experiments with TrkB-null mice suggest that TrkB signaling is required for oocyte survival after follicular assembly and for preantral follicular development.<sup>73</sup> The specific signaling mechanisms that mediate the effects of activins, inhibins, BMPs, and neurotrophins remain to be established.

Other paracrine factors mediate a bidirectional communication between oocytes and their surrounding granulosa cells. Oocytes are linked to their investment of granulosa cells via gap junctions, which allow passage of small molecules such as ions (e.g., calcium), metabolites (e.g., pyruvate, nucleic acids, inositol), amino acids (e.g., L-alanine), cholesterol, and intracellular signaling molecules (e.g., cyclic adenosine monophosphate, cAMP) between granulosa cells and oocytes. In mice, targeted deletions of gap junction proteins (known as connexins), disrupt follicular and oocyte development.<sup>70,74,75,76</sup>

Oocytes are unable to use glucose as an energy source to support meiotic maturation, cannot transport certain amino acids, and lack both the enzymes necessary for cholesterol synthesis and the receptors for its uptake from carrier-borne sources. Consequently, they are dependent on adjacent granulosa cells to metabolize glucose into a usable energy substrate, such as pyruvate, for transport of essential amino acids, such as L-alanine, and for synthesis and transfer of cholesterol.<sup>77</sup> **To meet their needs, oocytes stimulate glycolysis, amino acid transport, and cholesterol synthesis in granulosa cells via paracrine and juxtacrine signals that promote expression of transcripts involved in these metabolic processes, at least in some species.**<sup>77</sup>

Candidate signaling molecules include closely related members of the TGF- $\beta$  family, growth differentiation factor 9 (GDF9) and BMP15; both are expressed robustly in oocytes and appear crucial for normal ovarian follicle development in mammalian species.<sup>78</sup>

# Genital Duct Differentiation and Development

Caspar Wolff described the mesonephros in 1759 in his doctoral dissertation, at the age of 26.<sup>79</sup> The paired structures were named wolffian bodies by the 19th century embryologist, Rathke, in recognition of Wolff's initial discovery and description. Johannes Müller, a German physiologist, described the embryology of the genitalia in 1830. The paramesonephric ducts received his name, not because of his original contributions, but in recognition of his ability to synthesize the existing literature into a coherent concept.

The mesonephric (wolffian) and paramesonephric (müllerian) ducts are discrete primordia that coexist in all embryos during the ambisexual period of development (up to 8 weeks). Thereafter, one duct system persists, giving rise to specialized ducts and glands, and the other regresses, leaving behind only nonfunctional vestiges. **The wolffian duct develops first; differentiates into the epididymis, vas deferens, and seminal vesicles in males; and regresses in females. The müllerian duct develops later, even after the beginning of sex determination; differentiates into the fallopian tubes, uterus, and upper portion of the vagina in females; and regresses in males.**

The hormonal control of genital duct differentiation and development was established by the classic experiments of Alfred Jost.<sup>80</sup> His landmark studies demonstrated that hormones produced by the testis direct the sexual differentiation of both the internal and external genitalia in the male. Whereas testosterone stabilizes and promotes development of the wolffian ducts, AMH directs the regression of the müllerian system. In females, the wolffian ducts regress, in the absence of testosterone, and the müllerian ducts develop fully, in the absence of AMH. Although not yet clearly defined, our knowledge of the molecular mechanisms involved is growing steadily.

## Mesonephric (Wolffian) Duct Development

Testosterone is secreted by the fetal testes soon after Leydig cell formation (at 8 weeks of gestation) and rises rapidly to peak concentrations at 15–18 weeks. Fetal testosterone stimulates development of the wolffian duct system, from which the epididymis, vas deferens, and the seminal vesicles derive. Testosterone levels in the male fetus correlate with Leydig cell development, overall gonadal weight,  $3\beta$ -hydroxysteroid dehydrogenase activity, and chorionic gonadotropin (hCG) concentrations. As maternal hCG levels decline, beginning at approximately 20 weeks of gestation, Leydig cell testosterone secretion comes under the control of fetal pituitary luteinizing hormone (LH). In the absence of LH, as in males with anencephaly and other forms of congenital hypopituitarism, Leydig cells all but disappear and the internal and external genitalia do

not develop fully.<sup>81</sup>

Testosterone can reach the developing wolffian duct system via the systemic fetal circulation, but the paracrine actions of testosterone produced in nearby Leydig cells are more important for the stabilization and differentiation of the wolffian duct. **High local concentrations of testosterone stimulate the ipsilateral wolffian duct to differentiate into the epididymis, vas deferens, and seminal vesicle. Duct system differentiation proceeds, therefore, according to the nature of the adjacent gonad.** High concentrations of testosterone are required because the duct does not have the ability to convert testosterone to dihydrotestosterone (DHT).<sup>82</sup> In rodents, wolffian development can be induced in female embryos by treatment with exogenous androgens, but only to a limited extent,<sup>83</sup> because exogenous androgen treatment cannot achieve and maintain the high local concentrations required to induce duct differentiation. For the same reason, the wolffian ducts do not develop in female fetuses exposed to excess endogenous adrenal androgens, as in classical congenital adrenal hyperplasia (CAH), or to excess maternally derived androgens, as occurs in women with pregnancy luteoma. Testosterone acts via binding to androgen receptors in the wolffian duct, which are detectable in both males and females, but androgen production in females does not approach the levels required to promote wolffian duct differentiation.<sup>83</sup>

The paired wolffian ducts arise within the urogenital ridge during embryogenesis, running its length and terminating in the cloaca. The ducts form by a rearrangement of mesenchymal cells rather than by cell proliferation.<sup>84</sup> The regulatory signals involved have not been established, but evidence from studies in mice having targeted deletions of candidate genes has implicated a number of transcription factors, including PAX2, LIM1, and EMX2. All are expressed in mesenchymal condensations before duct formation and respond to opposing signals from adjacent mesoderm and overlying ectoderm, which appear to restrict their expression to the specific area in the mesoderm from which the ducts arise.<sup>84</sup> Along the axis of the forming wolffian ducts, a series of smaller tubules develop. The most anterior tubules fuse with the wolffian duct to become the precursors of the efferent ducts, ultimately connecting the testis to the epididymis; the more posterior or caudal tubules regress. In the human, parallel efferent ductules form multiple connections with the head (caput) of the epididymis.

Gradually, the straight wolffian ducts elongate and coil as a result of epithelial cell proliferation, stimulated by testosterone transported from the testes via the lumen of the duct, as well as by growth factors (e.g., epidermal growth factor, EGF; basic fibroblast growth factor, bFGF), which also are found in high concentrations in luminal fluid.<sup>85,86</sup> The structure of the developing epididymis becomes increasingly complex. Elongation and three-dimensional coiling begin at the end nearest the testis (the caput) and progress distally, except at the most caudal end of the duct, which remains straight and ultimately

gives rise to the vas deferens. The factors that stimulate or control coiling of the duct are uncertain but may involve a combination of regional signals from the surrounding mesenchyme, focal “hot spots” of epithelial cell growth, and physical space limitations.<sup>84</sup> Region-specific expression of homeobox (HOX) genes, which are transcriptional regulators of patterning, appears important for the differentiation of the duct into its morphologically and functionally distinct segments (caput, corpus, and caudal regions). For example, Hoxa10 and Hoxa11 appear to act distally to define the boundary between the epididymis and vas deferens.<sup>87</sup> Others HOX genes appear to direct differentiation of the seminal vesicle (derived from the posterior wolffian duct) and the prostate (derived from the urogenital sinus).<sup>88</sup> Evidence suggests that HOX genes may act by controlling the expression of other morphogenic factors such as inhibin beta A, which is expressed most highly in the greatly coiled caput region and to a progressively lesser extent in the mesenchyme surrounding more distal regions of the duct.<sup>89</sup> Growth factors in the testicular fluid also appear to play an important role in cellular differentiation along the length of the epididymis.<sup>90</sup>

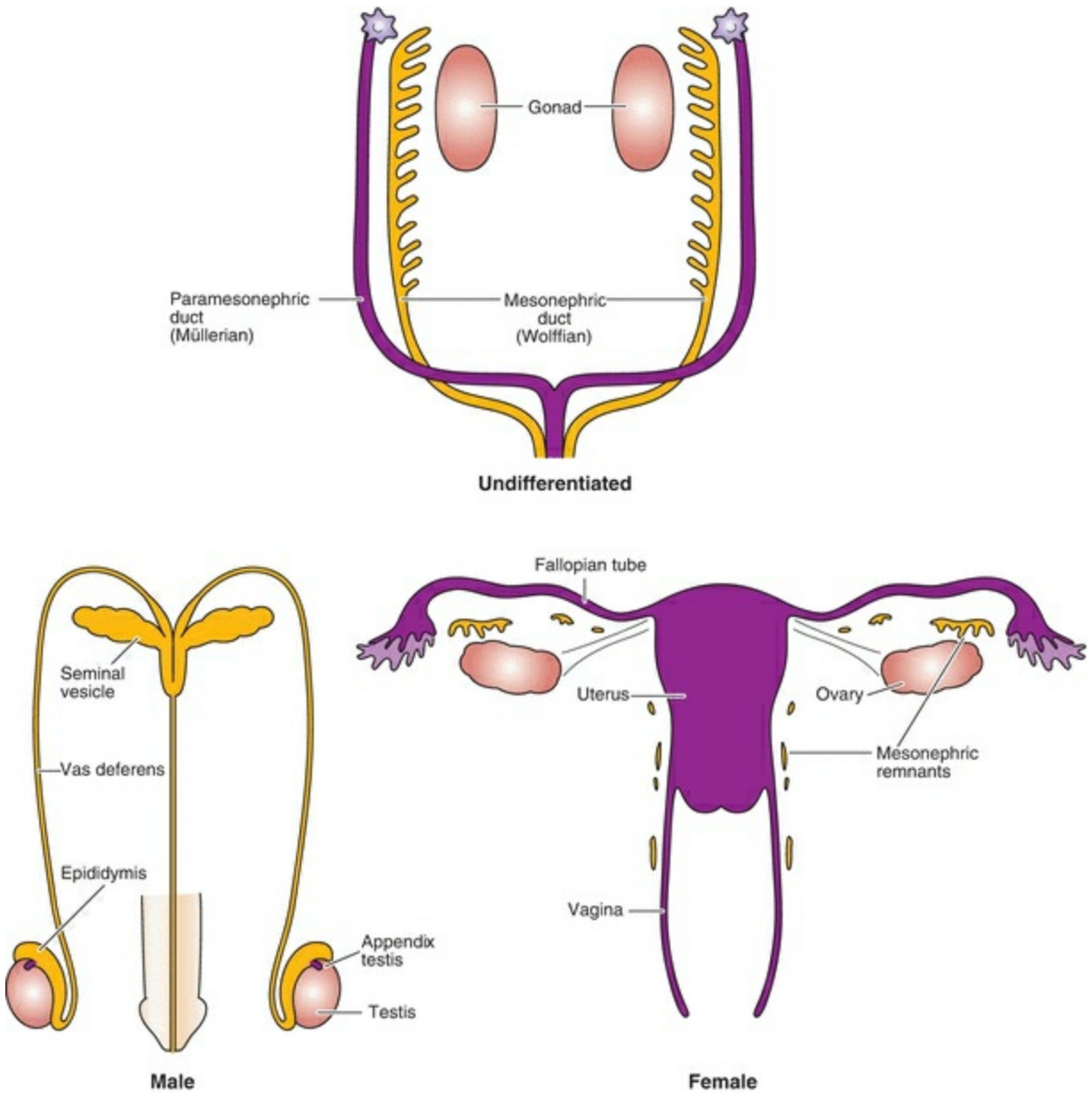
The extraordinary length of the epididymis—approximately 6 meters in the human—reflects its functional importance. **As sperms leave the testis, they are functionally immature, having neither full motility nor the ability to recognize and fertilize an oocyte.** They mature and acquire those functions as they pass through the epididymis, undergoing both biochemical and physical changes in a changing luminal environment regulated by a region-specific epididymal epithelium. The vas deferens is distinguished from the epididymis by its structure and by its function. It originates at the caudal end of the epididymis, where sperms are stored, and ends in the ejaculatory duct, which joins with the urethra. The vas deferens is surrounded by layers of smooth muscle that contract in response to sympathetic nerve stimulation, moving sperms through the vas deferens, into the ejaculatory duct (formed by the union of the vas with the duct of the seminal vesicle), and into the urethra.

## **Paramesonephric (Müllerian) Duct Development and Regression**

The müllerian ducts begin by invagination of the coelomic epithelium, which progresses until reaching the wolffian ducts, then elongate, by cellular proliferation, along the length of the wolffian ducts until reaching and fusing with the urogenital sinus.<sup>91</sup> The wolffian ducts make no direct contribution to the müllerian ducts, but are essential for normal müllerian development, serving as a guide or migrational template.<sup>92</sup> **If the wolffian ducts do not form, müllerian duct development also fails. Consequently, abnormalities in the renal system are highly associated with abnormalities in**

## **development of the fallopian tubes, uterus, and upper vagina.**

Müllerian duct development can be separated into three phases, each controlled by different genes, as demonstrated by careful analyses of mutant mice. Selection of the cells in the coelomic epithelium that will become the müllerian ducts is controlled by *Lim1*, which encodes a protein also involved in formation of the wolffian ducts.<sup>93</sup> Expression of *Wnt4* and other genes in the Wnt family (*Wnt7a*, *Wnt9b*) appears necessary for epithelial invagination.<sup>91</sup> *Pax2* is required for duct elongation<sup>94</sup> and, together with *Pax8*, also for differentiation of the duct into a uterus and vagina.<sup>95</sup> Directly or indirectly, müllerian duct development also involves other genes such as those encoding retinoic acid receptors; mice having targeted deletions of the retinoic acid receptors fail to develop müllerian ducts or to differentiate specific portions of the duct<sup>96</sup> (**Figure 8.5**).



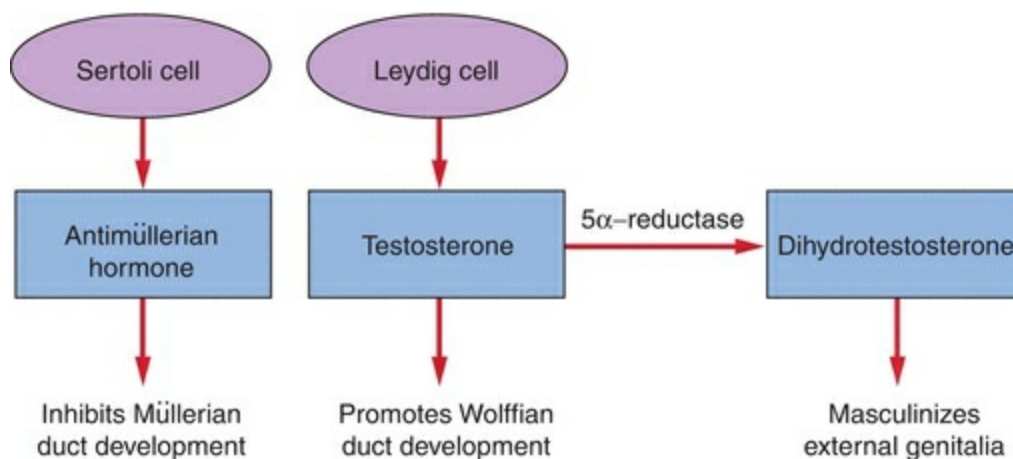
**FIGURE 8.5**

AMH is a member of the TGF- $\beta$  superfamily family of growth and differentiation factors that includes inhibin and activin.<sup>97,98</sup> The gene encoding AMH is located on the short arm of chromosome 19 (19p13.3). Like other members of the TGF- $\beta$  superfamily, AMH signaling is mediated via a heterodimeric receptor consisting of a type I and a type II serine/threonine kinase receptor; the type II part of the receptor mediates ligand specificity and the type I receptor activates a downstream signaling cascade. The specific type II receptor that binds AMH, called AMHR2, has been isolated in several mammalian species; in the human, the gene encoding AMHR2 is located on chromosome 12 (12q13). Three different type I receptors have been linked to AMH signaling—ALK2, ALK3, and ALK6; ALK2 and ALK3 appear particularly important, because



decreased expression or deletion of either disrupts müllerian duct regression.<sup>91</sup> **AMH gene expression is induced by SOX9 in Sertoli cells soon after testicular differentiation and results in the ipsilateral regression of the müllerian ducts by 8 weeks of gestation, before the emergence of testosterone and stimulation of the wolffian ducts.**<sup>99</sup> Inactivating mutations of AMH or AMHR2 result in persistent müllerian ducts in males.<sup>100</sup>

The process of müllerian duct regression involves a number of genes, but studies in mice indicate that *Wt1* and *Wnt7a* play key roles. AMH signaling induces coelomic epithelial cells expressing *Wt1*, *Amhr2*, and *Alk3* to migrate and surround the müllerian duct, transforming to mesenchymal cells in the process.<sup>101,102</sup> *Wnt7a* expression in the müllerian duct mesoepithelium promotes secretion of a signaling molecule (WNT7a) that activates AMHR2 in the neighboring mesenchymal cells via WT1, which binds and activates the *Amhr2* promoter.<sup>91</sup> At the same time,  $\beta$ -catenin gene expression increases in the mesenchymal cells surrounding the duct, and accumulation of  $\beta$ -catenin is accompanied by increased apoptosis in the müllerian ductal epithelium.<sup>101,102</sup> Whether WNT-dependent  $\beta$ -catenin activity is required to induce *Amhr2* expression or functions downstream of AMH signaling, or both, is not yet clear. Regardless, the process of müllerian duct regression appears to involve both apoptosis and the transition of ductal epithelial cells to mesenchymal cells.<sup>91</sup> The matrix metalloproteinase MMP2 also plays a role, by mediating destruction of the extracellular matrix; available evidence indicates that MMP2 activity also is AMH dependent, although the mechanism involved has not been established<sup>103</sup> (**Figure 8.6**).



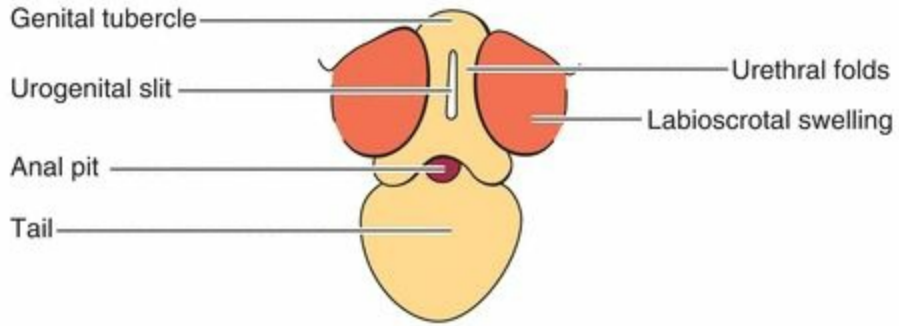
**FIGURE 8.6**

# Development of the External Genitalia

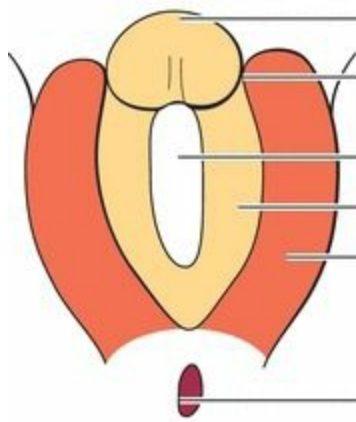
In the bipotential state, which persists until 9 weeks of gestation, the external genitalia consist of a genital tubercle, a urogenital sinus, and lateral labioscrotal folds or swellings. Unlike the internal genitalia where both duct systems initially coexist, the external genitalia are neutral primordia able to develop into either male or female structures, depending on gonadal steroid hormone signals.

In the male, the Leydig cells of the fetal testis begin to secrete testosterone at 8–9 weeks of gestation, and masculinization of the external genitalia begins 1 week later, at approximately 10 weeks. **The genital tubercle grows, forming the penis, the edges of the urogenital sinus fuse to form the penile urethra, and the labioscrotal folds fuse to form a scrotum.** The process typically is completed by 12–14 weeks of gestation. Thereafter, the principal change is in the growth and length of the penis. Complete development of the male external genitalia and differentiation of the prostate requires the conversion of testosterone to DHT, via the action of the intracellular enzyme 5 $\alpha$ -reductase. The genital tubercle and the labioscrotal swellings are highly sensitive to DHT, being rich in both androgen receptors and 5 $\alpha$ -reductase activity ([Figure 8.7](#)).

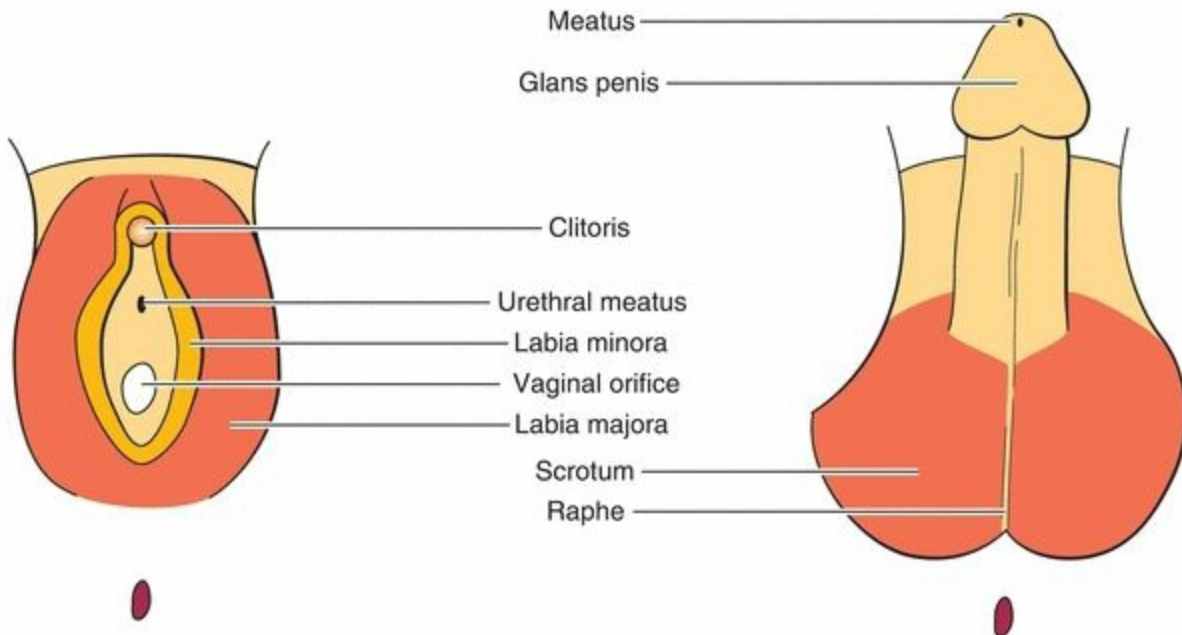
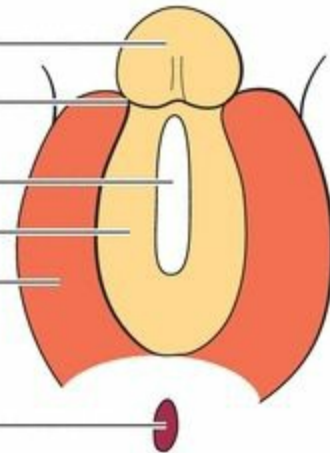
### Bipotential Stage



### Female



### Male



**FIGURE 8.7**

In the female, and in males with defects in androgen synthesis or action, the external genital primordia do not masculinize. **The genital tubercle remains small and becomes the clitoris, the margins of the urogenital sinus remain separate and form the labia minora, the labioscrotal folds form the labia majora, and the urogenital sinus develops into the lower vagina and urethra.**

In females, abnormal androgen exposure between 9 and 14 weeks of gestation results in varying degrees of masculinization, such as clitoral hypertrophy and labial fusion. In males, the external genitalia will not masculinize completely if androgen action is deficient during the same critical time interval, yielding a small phallus, hypospadias, or scrotal defects. **In both sexes, because the external genitalia share a common origin, genital ambiguity results from abnormalities in androgen action—in females from too much and in males from too little.**

# Sexual Differentiation of the Central Nervous System

Experimental evidence from studies in rodents and nonhuman primates suggests strongly that the fetal hormonal environment directs sexual differentiation of not only the genitalia but also the CNS. Treatment with testosterone during early development increases reproductive and other behaviors more common in males and decreases behaviors more common in females. These observations suggest that testosterone and its metabolites play a role in brain development and neuronal organization.<sup>104,105</sup>

Most of our knowledge about the early influence of testosterone on the brain and behavior in humans derives from clinical disorders associated with abnormal hormone production in early life, such as CAH. In male fetuses with classical CAH, sexual development progresses normally, but in female fetuses, testosterone is markedly elevated and causes masculinization of the external genitalia (clitoral enlargement and labial fusion). **Studies in girls with classical CAH indicate that increased prenatal androgen exposure also affects their brains and behavior.** Compared to unrelated age- and sex-matched controls or to unaffected female relatives of similar age, their toy preferences (vehicles, weapons) and play behaviors (rough, active play) are more typical of boys than of girls, to an extent that correlates with the severity of their disorder.<sup>4,106,107</sup> Girls with classical CAH also display more physical aggression and greater spatial abilities.<sup>108,109,110</sup> Although less well studied, there also is evidence to suggest that antenatal androgen exposure may influence sexual orientation. Whereas most females with classical CAH are heterosexual, as a group they are more likely to exhibit a bisexual or homosexual orientation; the effect is more pronounced in women with the severe salt-wasting form of CAH than in those with the milder, simple virilizing CAH.<sup>111</sup> Other studies observing a significant linear relationship between childhood behaviors and maternal serum or amniotic fluid testosterone concentrations during pregnancy suggest that even normal variations in prenatal androgen exposure may influence behavior, in both males and females.<sup>112,113</sup>

Presumably, the behavioral consequences of variations in prenatal androgen exposure reflect changes in neuronal development and organization. In rodents, an area of the anterior hypothalamic/preoptic region, called the sexually dimorphic nucleus of the preoptic area, is substantially larger in males than in females and treatment with androgens increases its size in females.<sup>104</sup> Whereas no comparable, specific, sexually dimorphic region has been identified in the human brain, there is some evidence from studies in females with classical CAH using functional MRI to suggest that prenatal androgen exposure may “masculinize” certain regions of the brain such as the amygdala, which is involved with regulation of emotion and aggression.<sup>114</sup> Variations in fetal

hormonal programming may contribute, therefore, to the spectrum of psychosexual behavior observed in humans. In addition, gender role is influenced heavily by the sex of rearing and by social interactions based upon genital appearance and secondary sexual characteristics.

# DISORDERS OF SEXUAL DEVELOPMENT

---

Disorders of sexual development (DSD) are congenital conditions characterized by atypical development of chromosomal, gonadal, or phenotypic sex. Traditionally, they have been classified according to gonadal sex. A **true hermaphrodite** has both ovarian and testicular tissue. A **male pseudohermaphrodite** has testes, but a female genital phenotype, and a **female pseudohermaphrodite** has ovaries, but masculine genital characteristics. However, recent advances in molecular genetic diagnosis and increasing awareness of ethical issues and patient advocacy concerns suggested the need to reexamine the traditional classification scheme and to retire gender-based terms that many now consider pejorative.

Ideally, a classification system must be flexible, to allow incorporation of new information, logical, to maintain a consistent structure, reflect genetic cause when that is known, and accommodate the spectrum of phenotypic variation. The classification and nomenclature used here, organized by chromosomal composition and causation, conform with recommendations arising from a 2006 consensus conference involving experts in pediatric endocrinology and other specialties involved in the management of patients with DSD ([Table 8.1](#)).<sup>115</sup>

## TABLE 8.1 Disorders of Sexual Development

<b>46,XX disorders of sexual development</b>	<p>Disorders of gonadal (ovarian) development</p> <p>Ovotesticular disorder of sexual development (true hermaphroditism)</p> <p>Testicular disorder of sexual development (46,XX male sex reversal)</p> <p>Gonadal dysgenesis</p> <p>Androgen excess—fetal origin (congenital adrenal hyperplasia)</p> <ul style="list-style-type: none"> <li>• 21-hydroxylase (P450c21) deficiency</li> <li>• 11<math>\beta</math>-hydroxylase (P450c11b) deficiency</li> <li>• 3<math>\beta</math>-hydroxysteroid dehydrogenase deficiency</li> </ul> <p>Androgen excess—fetoplacental origin</p> <ul style="list-style-type: none"> <li>• Aromatase (P450arom) deficiency</li> <li>• P450 oxidoreductase deficiency</li> </ul> <p>Androgen excess—maternal origin (gestational hyperandrogenism)</p> <ul style="list-style-type: none"> <li>• Drug ingestion</li> <li>• Excess androgen production <ul style="list-style-type: none"> <li>◦ Pregnancy luteoma</li> <li>◦ Theca-lutein cysts</li> </ul> </li> </ul> <p>Other disorders of genital development</p> <ul style="list-style-type: none"> <li>• Cloacal exstrophy</li> <li>• Müllerian agenesis (Mayer-Rokitansky-Küster-Hauser syndrome)</li> <li>• Müllerian, renal, and cervicothoracic somite dysplasia (MURCS association)</li> </ul>
<b>46,XY disorders of sexual development</b>	<p>Disorders of gonadal (testicular) development</p> <ul style="list-style-type: none"> <li>• Complete gonadal dysgenesis (Swyer syndrome)</li> <li>• Partial gonadal dysgenesis</li> <li>• Testicular regression syndrome</li> <li>• Ovotesticular disorder of sexual development</li> </ul> <p>Disorders of androgen synthesis</p> <ul style="list-style-type: none"> <li>• Steroid 5<math>\alpha</math>-reductase deficiency</li> <li>• 17<math>\alpha</math>-hydroxylase (P450c17) deficiency</li> <li>• 3<math>\beta</math>-hydroxysteroid dehydrogenase deficiency</li> <li>• 17<math>\beta</math>-hydroxysteroid dehydrogenase deficiency</li> <li>• P450 oxidoreductase deficiency</li> <li>• Steroid acute regulatory (StAR) protein deficiency</li> </ul> <p>Disorders of androgen action</p> <ul style="list-style-type: none"> <li>• Complete androgen insensitivity syndrome</li> <li>• Incomplete (partial) androgen insensitivity syndromes</li> </ul> <p>LH receptor defects</p> <ul style="list-style-type: none"> <li>• Leydig cell hypoplasia</li> </ul> <p>Disorders of antimüllerian hormone (AMH) and its receptor</p> <ul style="list-style-type: none"> <li>• Hernia uterine inguinale syndrome</li> </ul>
<b>Sex chromosome disorders of sexual development</b>	<p>45,X (Turner syndrome and variants)</p> <p>47,XXY (Klinefelter syndrome and variants)</p> <p>45,X/46,XY (mixed gonadal dysgenesis, ovotesticular disorder of sexual development)</p> <p>46,XX/46,XY (chimerism, ovotesticular disorder of sexual development)</p>



## 46,XX Disorders of Sexual Development

DSD in chromosomal females can result from abnormalities in gonadal development, but most are caused by androgen excess, which may be of fetal, fetoplacental, or maternal origin. Excess fetal androgen production results from steroidogenic enzyme deficiencies causing CAH. Androgen excess of fetoplacental origin results from enzyme deficiencies involving both the fetal adrenal and the placenta. Maternal androgen excess can result from the ingestion of drugs having androgenic properties and from disorders causing gestational hyperandrogenism.

### Disorders of Gonadal (Ovarian) Development

Rarely, 46,XX DSD can result from abnormalities of gonadal development, which include ovotesticular DSD (true hermaphroditism), testicular DSD (46,XX sex reversal), and gonadal dysgenesis.

#### Ovotesticular Disorder of Sexual Development (True Hermaphroditism)

Ovotesticular DSD previously was called true hermaphroditism.<sup>115</sup> Hermaphroditus, the Greek god with bisexual attributes, was the child of Hermes—the god of athletics, secrets, and occult philosophy—and Aphrodite, the goddess of love. The bisexual theme was immortalized in Greek and Roman sculptures depicting a woman with male external genitalia. Pliny (23–79 A.D.) was the first to apply the term hermaphrodite to humans, offering a description in his massive work, *Historia Naturalis*.

Ovotesticular DSD is a rare condition characterized by mixed ovarian and testicular tissue, which may include bilateral ovotestes or an ovotestis and a contralateral ovary or testis. The disorder is described here because the majority of patients have a 46,XX karyotype. However, because 7% of patients with ovotesticular DSD have a 46,XY karyotype and 10–40% exhibit chromosomal mosaicism,<sup>116</sup> the disorder also must be listed among the causes of 46,XY and sex chromosome disorders of sexual development.

Whereas gonads containing testicular tissue are observed most frequently on the right, normal ovaries are observed most often on the left.<sup>116</sup> Usually, both müllerian and wolffian internal genital structures are present, and as could be predicted, internal genital structures correspond with the adjacent gonad. Whereas most have a vagina, the uterus can be normal and functional, hypoplastic, vestigial, or altogether absent.<sup>116,117</sup> External genital development reflects the level of androgen production and exposure, and the phenotype can range widely, from ambiguous genitalia to isolated hypospadias.

Most are virilized sufficiently to allow male sex assignment, but three-fourths develop gynecomastia and half menstruate after puberty.

The genetics and pathophysiology of ovotesticular DSD are not well established. Mechanisms that might explain the testicular development include the translocation of testis-determining genes from the Y to the X chromosome or an autosome and autosomal dominant mutations that promote testis development in the absence of a Y chromosome.<sup>118</sup> In one individual, the condition has been associated with an inactivating mutation in the RSPO1 gene,<sup>119</sup> which is located on chromosome 1p34.2–3.

## **Testicular Disorder of Sexual Development (46,XX Sex Reversal)**

Testicular DSD is a rare “sex reversal” syndrome in which the chromosomal sex (46,XX) is not consistent with the gonadal sex (testes). The disorder was first described by de la Chapelle in 1964<sup>120</sup> and can be divided into two types, SRY positive and SRY negative. **Approximately 90% of cases result from abnormal recombination between the distal portions of the short arms of the X and Y chromosomes and transfer of SRY from the Y to the X chromosome during male meiosis; in 10% of cases, SRY cannot be detected.**<sup>121</sup> In most SRY-negative patients, the mechanism causing testis development cannot be determined.<sup>121,122,123,124</sup>

Although some patients with SRY-positive testicular DSD have ambiguous genitalia, which may result from preferential inactivation of the SRY-bearing X chromosome,<sup>125</sup> the large majority are sterile males with normal genital development, a normal male hair pattern, and short stature. Consequently, unless they have cryptorchid testes, most are not recognized until after puberty, when they may present with hypogonadism, gynecomastia, and/or infertility.<sup>121</sup> In contrast, SRY-negative XX males usually have ambiguous genitalia and often develop gynecomastia or fail to masculinize fully after puberty.<sup>121,122,123,124</sup> Rarely, they may exhibit occult gonadal mosaicism for SRY.<sup>126</sup> In some, the phenotype has been linked to a duplication of sequences on chromosome 17q, including the SOX9 gene, which acts downstream of SRY in the testis-determining pathway.<sup>32,127</sup> However, in most patients with SRY-negative testicular DSD, the cause remains unclear. In theory, XX male sex reversal might result from an inactivating mutation or deletion in genes encoding factors that inhibit testis development, but there is no direct evidence that they are a cause of testicular DSD.<sup>122</sup>

## **Gonadal Dysgenesis**

Some individuals with primary amenorrhea, hypergonadotropic hypogonadism, and gonadal dysgenesis (streak gonads) have a normal 46,XX karyotype, providing indirect evidence that autosomal genes also play a critical role in ovarian differentiation.

Affected women are normal in stature and, in most cases, have no apparent somatic anomalies. A wide variety of candidate genes have been identified, primarily via experiments involving murine knockout models, including several that encode DNA- and RNA-binding proteins and transcription factors expressed during oogenesis.<sup>128</sup>

## **Androgen Excess—Fetal Origin (Congenital Adrenal Hyperplasia)**

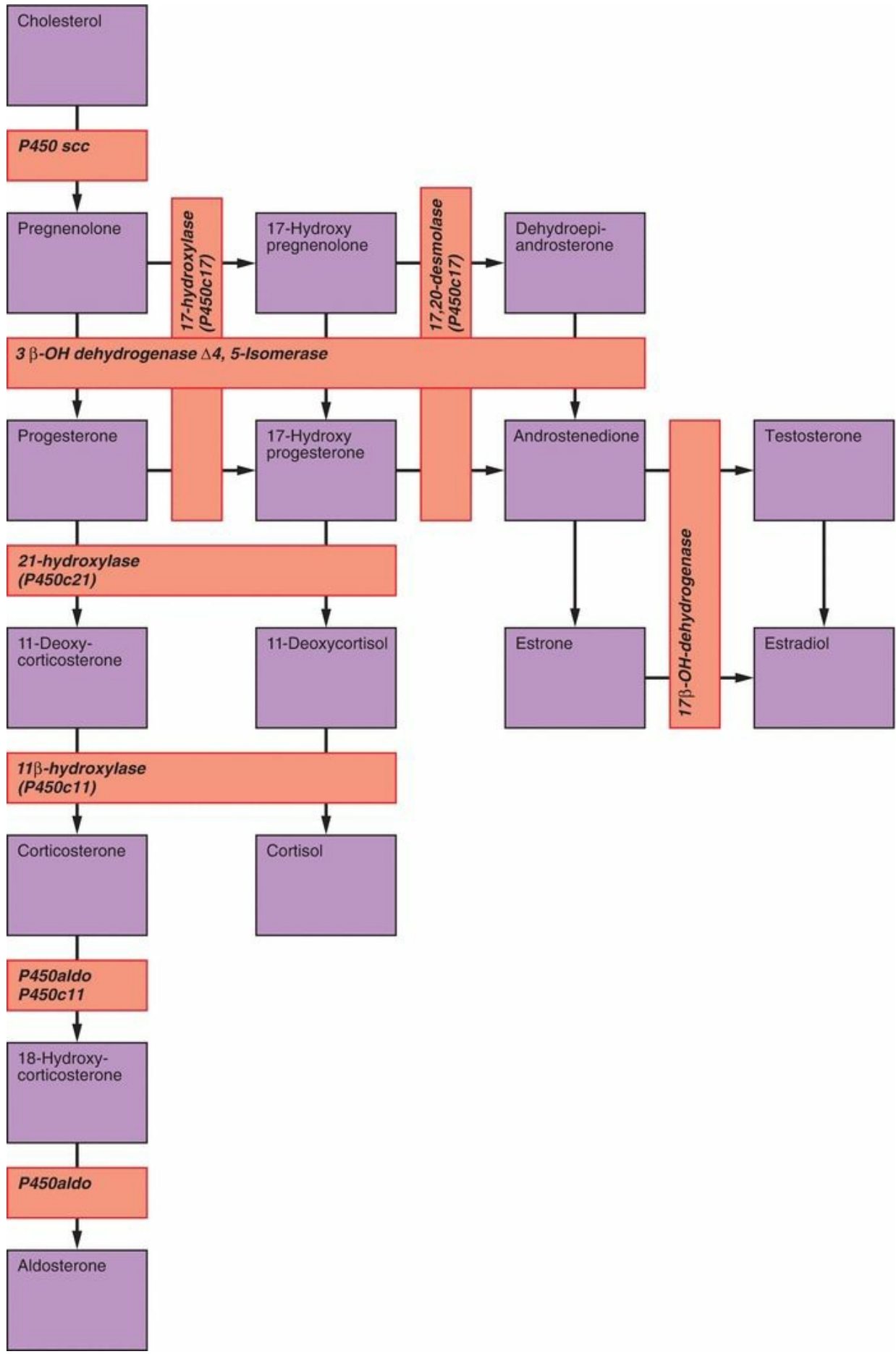
Virilizing CAH is a genetic disorder caused by enzyme defects in adrenal cortisol biosynthesis. More than 90% of cases result from a deficiency in the enzyme 21-hydroxylase.<sup>129,130,131</sup> Deficiencies of 11 $\beta$ -hydroxylase and 3 $\beta$ -HSD are less common causes of CAH. **In all, the pathophysiology relates primarily to decreased cortisol production, which stimulates a compensatory increase in pituitary adrenocorticotrophic hormone (ACTH) secretion, causing adrenal hyperplasia; increased levels of steroid hormones proximal to the enzyme block seek an alternative metabolic pathway, resulting in increased production of androgens.**

In females, the classic forms of CAH (with and without salt wasting) are characterized by genital ambiguity. **Depending on the time, duration, and level of exposure, abnormally high androgen concentrations in utero result in varying degrees of clitoral enlargement and labial fusion and abnormalities of the urethra and vagina; generally, the urethra and vagina share a urogenital sinus that opens at the base of the clitoris.** The fetal adrenal cortex does not achieve a significant level of function before 10 weeks of gestation, and by that time, the vagina and urethra normally have become separated. However, between 10 and 12 weeks, rising androgen levels can promote progressive clitoral enlargement, labial fusion, and even partial closure of the urethra. At birth, the genital anatomy is similar to that in males with hypospadias and bilateral cryptorchidism and can result in incorrect sex assignment. The effects of elevated adrenal androgen levels arising after 12–14 weeks of gestation are more limited. **Female external genital development normally is not completed until approximately 20 weeks of gestation, and the size of the clitoris depends more on the level than on the timing of excess androgen exposure.** Development of the internal genitalia is normal in females with classical CAH because the excess androgen derives from the adrenals and the normal ovaries produce neither AMH nor significant amounts of androgen. **Absent AMH and the high local androgen concentrations required to promote wolffian duct development, the fallopian tubes, uterus, and upper vagina develop normally.**

### **21-Hydroxylase (P450c21) Deficiency**

The enzyme 21-hydroxylase (also designated P450c21 and CYP21A2) mediates the conversion of 17 $\alpha$ -hydroxyprogesterone (17-OHP) to 11-deoxycortisol (the immediate precursor of cortisol) and of progesterone to 11-deoxycorticosterone (an intermediate steroid in aldosterone synthesis). **CAH due to 21-hydroxylase deficiency is the most frequent cause of sexual ambiguity and the most common endocrine cause of neonatal death.** The more serious “salt-wasting” variety of classical 21-hydroxylase deficiency is characterized by severe deficiencies of both cortisol and aldosterone, resulting in salt wasting and dehydration, in addition to virilization. In the less severe “simple virilizing” form of the disorder, elevated levels of ACTH are able to drive sufficient glucocorticoid and mineralocorticoid production to prevent circulatory collapse, but excess androgen production in utero results in masculinization of the external genitalia. The third and least severe “nonclassical” form of 21-hydroxylase deficiency generally does not become apparent until adolescence or early adulthood, when abnormally high androgen levels cause hirsutism and menstrual irregularities.

Data derived from neonatal screening programs for detection of classical CAH indicate that prevalence varies widely with ethnicity. Whereas the overall prevalence is approximately 1 in 15,000 live births,<sup>132</sup> prevalence ranges from 1 in 28,000 Chinese<sup>133</sup> and between 1 in 5,000 and 1 in 23,000 Caucasians,<sup>134,135</sup> to as high as 1 in 280 Yupik Eskimos.<sup>136</sup> In the United States, the prevalence of classical CAH is lower in African Americans (1 in 42,000) than in Caucasians (1 in 15,500).<sup>137</sup> Approximately two-thirds exhibit salt wasting, and one-third has the simple virilizing form of the disorder (**Figure 8.8**).



## FIGURE 8.8

Nonclassical 21-hydroxylase deficiency is one of the most common autosomal recessive diseases, and as in the classical form of the disorder, prevalence varies with ethnicity. Nonclassical 21-hydroxylase deficiency affects between 1 in 100 and 1 in 1,000 Caucasians<sup>136,137,138</sup> and may be even more common among those of Mediterranean, Hispanic, Slavic, and Eastern European Jewish descent.<sup>139</sup> Most affected individuals are not identified in neonatal screening programs because their serum levels of 17-OHP are not sufficiently elevated.<sup>140</sup> Estimates of the carrier frequency (heterozygotes) for nonclassical 21-hydroxylase deficiency generally have ranged between 1 in 60 and 1 in 80 individuals<sup>133,136</sup> but have been as high as 1 in 10 in a European population.<sup>141</sup>

All forms of CAH, including 21-hydroxylase deficiency, are transmitted as autosomal recessive disorders. Humans have two CYP21A genes; one is a nonfunctional pseudogene (CYP21A1, also designated CYP21P, encoding an inactive form of the enzyme), and the other is the active gene (CYP21A2). The two genes have greater than 90% homology and reside in the same region within the HLA histocompatibility complex on the short arm of chromosome 6 (6p21.3), which provides ample opportunity for recombination during meiosis.<sup>142,143,144,145</sup> Most CYP21A2 mutations (approximately 75%) result from nonreciprocal gene conversions in which a segment of the CYP21A1 pseudogene is inserted into the active CYP21A2 gene, altering its sequence and resulting in point mutations that yield a defective enzyme.<sup>144,145,146,147,148</sup> Approximately 20% of CYP21A2 mutations result from unequal crossover exchanges between the two genes, yielding a larger fusion gene that produces an enzyme having reduced or no activity.<sup>134,139,148,149</sup> About 20 gene conversion mutations account for almost all of the affected alleles observed among various ethnic groups.<sup>147,150,151,152,153,154,155,156,157</sup> The remaining 5% of patients with CYP21A2 mutations have 1 or 2 of the more than 60 different point mutations that have been identified.<sup>147,150,151,152</sup>

**Women who carry a classic mutation are at risk for having a child with the severe form of the disorder.** They may be asymptomatic, having one classic mutation and one normal allele, or exhibit the nonclassical form of CAH, having one classic mutation and a variant allele associated with mild enzyme deficiency (compound heterozygote). Compound heterozygotes having two variant alleles can exhibit the features of nonclassical CAH but are not at risk for having a child with classical CAH.

Although phenotype does not reliably predict genotype, the effect of a given mutation generally can be predicted by site-directed mutagenesis and expression and by

analysis of enzyme activity in vitro.<sup>138,147,153,154,155,156,158,159,160,161,162,163,164,165</sup>

- The salt-wasting form of classical 21-hydroxylase deficiency usually is associated with large gene deletions or a mutation that affects splicing and results in no enzyme activity.
- Patients with the simple virilizing form of classical 21-hydroxylase deficiency most often have point mutations that result in low but detectable enzyme activity (e.g., 1–2% of normal) that supports adequate aldosterone and cortisol production.
- Those with the nonclassical form of 21-hydroxylase deficiency usually are compound heterozygotes, having one classic mutation and one variant allele or two variant alleles; the phenotype of compound heterozygotes usually correlates with the less severe of the two mutations.<sup>150</sup>
- Heterozygotes may exhibit biochemical abnormalities but typically have no clinically significant endocrinopathy.<sup>166,167</sup>

**Females with classical 21-hydroxylase deficiency (both salt-wasting and simple virilizing forms) present at birth with ambiguous genitalia (adrenogenital syndrome).**<sup>168,169,170</sup> Boys with salt-wasting CAH typically present as neonates or during early infancy with symptoms of adrenal insufficiency (failure to thrive, dehydration, hyponatremia, hyperkalemia), and those with simple virilizing CAH not identified by neonatal screening generally present as young children with early virilization. **Females with the nonclassical “late-onset” form of 21-hydroxylase deficiency have normal external genitalia and present later, during childhood or early adolescence with precocious puberty, or as young adults with other signs of hyperandrogenism such as hirsutism.**

As discussed earlier in this chapter in reference to the sexual differentiation of the CNS, females with classical CAH tend to exhibit greater interest in male-typical toys and play and more cross-gender and aggressive behavior than do unaffected healthy women.<sup>4,106,107,108,109,110,111</sup> Studies of cognitive function in women with classical CAH have yielded inconsistent results. Whereas some have suggested that such women exhibit lower<sup>171,172</sup> or higher intelligence<sup>173</sup> and differences in verbal learning and memory,<sup>174,175</sup> compared to unaffected women, others have found no evidence to indicate that prenatal androgen exposure has a consistent or predictable effect on cognition in women with CAH.<sup>176</sup>

**Fertility in women with classical CAH is lower than that in normal women,<sup>3,111</sup> primarily due to chronic anovulation relating to excess production of adrenal androgens and progestogens (progesterone, 17-OHP) and disordered patterns of gonadotropin secretion<sup>151</sup>; abnormalities of genital anatomy and psychological**

**factors, such as delayed psychosexual development and decreased sexual activity, also contribute.**<sup>177</sup> In one study of quality of life in women with classical CAH, half reported that their disease adversely affected their sexual life and most were less than satisfied with their genital anatomy and function, regardless whether they had received reconstructive surgery; vaginal stenosis or narrowing were commonly observed.<sup>178</sup> Women with classical CAH also had a later sexual debut and fewer pregnancies and children. Fertility rates correlate with the severity of the disorder and are significantly lower in women with salt wasting than in those with the simple virilizing form of classical CAH.<sup>179</sup> However, outcomes of pregnancies among women with classical CAH who conceive are normal except for an increased incidence of gestational diabetes.<sup>177</sup> Children born to mothers with classical CAH have normal birth weight, have no increased incidence of malformations, and exhibit normal intellectual and social development.<sup>177,180</sup> **Although maternal serum androgen concentrations can increase significantly during pregnancy and should be monitored, the high capacity of placental aromatase activity effectively protects the female fetus from the masculinizing effects of maternal hyperandrogenism.**<sup>180</sup>

Diagnosis of 21-hydroxylase deficiency is based on a high serum concentration of 17-OHP, the primary substrate for the enzyme. **In neonates with either salt-wasting or simple virilizing CAH, 17-OHP levels typically are greater than 3,500 ng/dL**<sup>129,181</sup>; **levels in normal newborns generally are below 100 ng/dL.**<sup>147</sup> To distinguish 21-hydroxylase deficiency from other causes of CAH (11 $\beta$ -hydroxylase and 3 $\beta$ -HSD deficiencies), serum concentrations of 11-deoxycortisol and 17 $\alpha$ -hydroxypregnenolone also should be measured. When the diagnosis is suspected but uncertain, it can be confirmed by performing an ACTH stimulation test, obtaining blood samples before and 60 minutes after administering cosyntropin (synthetic ACTH 1–24; 1 mg/m<sup>2</sup> or 0.25 mg)<sup>182</sup>; in affected infants, stimulated 17-OHP levels typically exceed 10,000 ng/dL.<sup>168</sup> Diagnosis also can be confirmed by genotyping, which can detect approximately 95% of mutations.<sup>183</sup>

In couples known to be at risk for having an affected child (affected sibling, both partners carriers for a classic mutation), prenatal diagnosis is possible by genotyping amniocytes or, preferably, cells obtained by chorionic villus sampling (CVS).<sup>139,152</sup> Early prenatal diagnosis offers the option for intervention, before the most critical period of fetal genital differentiation, in efforts to avoid severe masculinization of the external genitalia in affected female fetuses.

Neonatal screening programs measure 17-OHP in blood samples dried on filter paper, comparing results to established reference values that vary with weight and gestational age.<sup>184,185</sup> Antenatal corticosteroid treatment can decrease 17-OHP levels



and increase the risk for a false-negative result, particularly when administered repeatedly<sup>186</sup>; screening can be repeated at 1–2 weeks of age, with careful monitoring in the interim, or genotyping can be performed on the dried blood sample.<sup>187</sup>

In the late-onset nonclassical form of 21-hydroxylase deficiency, serum 17-OHP concentrations often are only slightly elevated, especially late in the day, and the serum dehydroepiandrosterone sulfate (DHEA-S) concentration usually is normal. In children, morning values greater than 82 ng/dL suggest the diagnosis, which can be confirmed by performing an ACTH stimulation test. **In adult women, morning values less than 200 ng/dL (obtained during the early follicular phase of the cycle) exclude the diagnosis, levels over 800 ng/dL are virtually diagnostic, and intermediate results require additional evaluation with an ACTH stimulation test; in most patients with nonclassical 21-hydroxylase deficiency, the stimulated 17-OHP level will exceed 1,500 ng/dL.**<sup>139,181,188</sup> A 21-hydroxylase deficiency can be distinguished from 11 $\beta$ -hydroxylase and 3 $\beta$ -HSD deficiencies by also measuring 11-deoxycortisol and 17 $\alpha$ -hydroxypregnenolone, but the distinction in patients with late-onset CAH has little or no clinical relevance and generally is unnecessary.

## 11 $\beta$ -Hydroxylase (P450c11) Deficiency

The enzyme 11 $\beta$ -hydroxylase (also designated P450c11 and CYP11B1) mediates the conversion of 11-deoxycortisol to cortisol and of 11-deoxycorticosterone to corticosterone (an intermediate steroid in aldosterone synthesis). The clinical features of 11 $\beta$ -hydroxylase deficiency result from the excess production of adrenal androgens and the mineralocorticoid action of 11-deoxycorticosterone; 11-deoxycortisol has no significant biologic activity.

Although 11 $\beta$ -hydroxylase deficiency is the second most common cause of CAH, it accounts for only about 5–8% of adrenal steroid enzyme defects.<sup>168,169,189</sup> Like 21-hydroxylase deficiency, 11 $\beta$ -hydroxylase deficiency has severe salt-wasting and simple virilizing forms and a milder late-onset form. In females, 11 $\beta$ -hydroxylase deficiency can result in virilization of the external genitalia, but also may present later, in children with sexual precocity or in adolescent or young women with hirsutism and menstrual irregularity.<sup>190,191,192</sup> In most affected individuals, the disorder has unique clinical features that help to distinguish it from 21-hydroxylase deficiency. **Whereas both 21-hydroxylase deficiency and 11 $\beta$ -hydroxylase deficiency may result in salt wasting, approximately two-thirds of patients with 11 $\beta$ -hydroxylase deficiency exhibit hypertension due to an increased production of mineralocorticoids.**<sup>189,193,194,195</sup> Hypokalemia also may be observed and plasma rennin activity often is low. These effects generally have been attributed to excess production of 11-deoxycorticosterone, which has significant mineralocorticoid activity, although blood pressure and serum 11-

deoxycorticosterone concentrations do not correlate closely.<sup>190,196</sup> The explanation for the wide variation in the clinical manifestations of 11 $\beta$ -hydroxylase deficiency is not clear.

The overall incidence of 11 $\beta$ -hydroxylase deficiency is approximately 1 in 100,000 live births, but like 21-hydroxylase deficiency, incidence varies with ethnicity. In Israel, the incidence of 11 $\beta$ -hydroxylase deficiency is as high as 1 in 5,000 births among Jews of Moroccan ancestry.<sup>197</sup> The enzyme deficiency is an autosomal recessive disorder caused by mutations in the CYP11B1 gene, which is located on the long arm of chromosome 8 (8q21–q22). The known mutations include missense mutations that result in production of an inactive enzyme,<sup>165,198,199,200</sup> frameshift and nonsense mutations that prevent enzyme synthesis,<sup>201,202,203</sup> and others resulting from unequal recombination between the CYP11B1 and CYP11B2 genes.<sup>204,205</sup> The CYP11B2 gene is located in the same region on chromosome 8 and encodes an enzyme having both 11 $\beta$ -hydroxylase and 18-hydroxylase (also designated P450c18 or P450aldo) activity, mediating the conversion of corticosterone to 18-hydroxycorticosterone and, subsequently, aldosterone. There are no specific correlations between genotype and phenotype in patients with 11 $\beta$ -hydroxylase deficiency.<sup>206</sup> Although the late-onset form of 11 $\beta$ -hydroxylase deficiency may be caused by mutations yielding an enzyme with reduced but still significant activity, none has yet been identified.

**Diagnosis of 11 $\beta$ -hydroxylase deficiency is based on demonstrating high serum concentrations of 11-deoxycortisol and 11-deoxycorticosterone, as well as testosterone; both basal and ACTH-stimulated levels generally are elevated in affected neonates.<sup>189,207,208</sup> In adolescents and young adults, basal 11-deoxycortisol and 11-deoxycorticosterone levels may be normal and ACTH stimulation often is required to make the diagnosis; results must be compared to established age and sex-specific normal values.**

### **3 $\beta$ -Hydroxysteroid Dehydrogenase Deficiency**

The enzyme 3 $\beta$ -hydroxysteroid dehydrogenase/D<sup>5</sup>-D<sup>4</sup> isomerase (3 $\beta$ -HSD) catalyzes the oxidation and isomerization of D<sup>5</sup>-3 $\beta$ -hydroxysteroid precursors into D<sup>4</sup>-ketosteroids, an essential step in the formation of all classes of steroid hormones (glucocorticoids, mineralocorticoids, progestogens, androgens, and estrogens). There are two 3 $\beta$ -HSD isoenzymes, designated type I and type II. The type I 3 $\beta$ -HSD gene (HSD3B1) mediates 3 $\beta$ -HSD activity in the placenta and peripheral tissues (skin, breasts, prostate) and the type II 3 $\beta$ -HSD gene (HSD3B2) is active in the adrenal, ovary, and testis. Deficiency of type II 3 $\beta$ -HSD causes an uncommon form of CAH, accounting for less than 5% of cases.<sup>209</sup> The type I isoenzyme is normal in patients with 3 $\beta$ -HSD deficiency.

Consequently, serum concentrations of D<sup>4</sup> steroids, such as 17-OHP and androstenedione, can be normal or even sometimes modestly elevated in affected patients. Serum levels of the substrates for the type I enzyme (pregnenolone, 17 $\alpha$ -hydroxypregnenolone, DHEA) are increased due to the defect in the type II enzyme in the adrenals and gonads.

The clinical presentation of patients with 3 $\beta$ -HSD deficiency varies significantly, but can be divided into salt-wasting and non-salt-wasting forms. The salt-wasting form has been associated with nonsense mutations introducing stop codons,<sup>210</sup> frameshift mutations,<sup>210,211,212</sup> and a variety of point mutations in the HSD3B2 gene.<sup>213,214,215,216,217</sup> Those with the non-salt-wasting form have had missense mutations causing single amino acid substitutions that dramatically decrease the enzyme's affinity for substrates or cofactors.<sup>217,218,219,220</sup>

**The external genitalia of females with 3 $\beta$ -HSD deficiency can be mildly virilized, presumably because DHEA levels are high and some is converted to androstenedione and, subsequently, to testosterone in the periphery.** Whereas the salt-wasting form of classical 3 $\beta$ -HSD deficiency (analogous to those of 21-hydroxylase and 11 $\beta$ -hydroxylase deficiencies) usually is diagnosed during the first few months of life, the non-salt-wasting form of the disorder generally presents later. In females, because the external genitalia often are normal at birth, diagnosis of the non-salt-wasting form of 3 $\beta$ -HSD deficiency typically is delayed, presenting in childhood with premature pubarche or in young women with signs of hyperandrogenism.<sup>209</sup>

Although basal levels of D<sup>5</sup>-3 $\beta$ -hydroxy steroids (pregnenolone, 17 $\alpha$ -hydroxypregnenolone, DHEA, and DHEA-S) generally are elevated in affected individuals, an increased ratio of D<sup>5</sup>/D<sup>4</sup> steroids is a better indication of a possible 3 $\beta$ -HSD deficiency. **The most reliable diagnostic criterion is the serum 17 $\alpha$ -hydroxypregnenolone concentration after ACTH stimulation.** Proposed threshold values are based on observations in patients with documented mutations (neonates,  $\geq 12,600$  ng/dL; Tanner stage I children  $\geq 5,490$  ng/dL, children with premature pubarche,  $\geq 9,790$  ng/dL; adults  $\geq 9,620$  ng/dL). Some have argued that many women with a clinical diagnosis of polycystic ovary syndrome actually may have a late-onset form of 3 $\beta$ -HSD deficiency that may be as or more common than the late-onset form of 21-hydroxylase deficiency.<sup>221</sup> An exaggerated 17 $\alpha$ -hydroxypregnenolone response to ACTH stimulation is relatively common in women with hyperandrogenism, but levels rarely approach those observed in women with proven mutations, suggesting that the response likely reflects only adrenal hyperactivity and not an enzyme deficiency.<sup>222</sup> Furthermore, molecular studies have only rarely identified any mutations in HSD3B2 in patients suspected of having a mild form of 3 $\beta$ -HSD deficiency.<sup>223,224,225</sup>

## Treatment of Congenital Adrenal Hyperplasia

Treatment for classical forms of CAH is aimed at providing sufficient amounts of the deficient hormone, cortisol, to reduce excessive ACTH secretion and to prevent the consequences of excessive androgen production. In mothers at risk for having an affected child, treatment can reduce or prevent masculinization of a female fetus. In neonates with classical CAH, treatment can be lifesaving and prevents further virilization. In children, treatment permits normal growth and sexual maturation. In adults with classical or nonclassical CAH, treatment helps in the management of hirsutism, menstrual abnormalities, and infertility.

## Preimplantation Genetic Diagnosis in Couples at Risk for Having an Affected Child

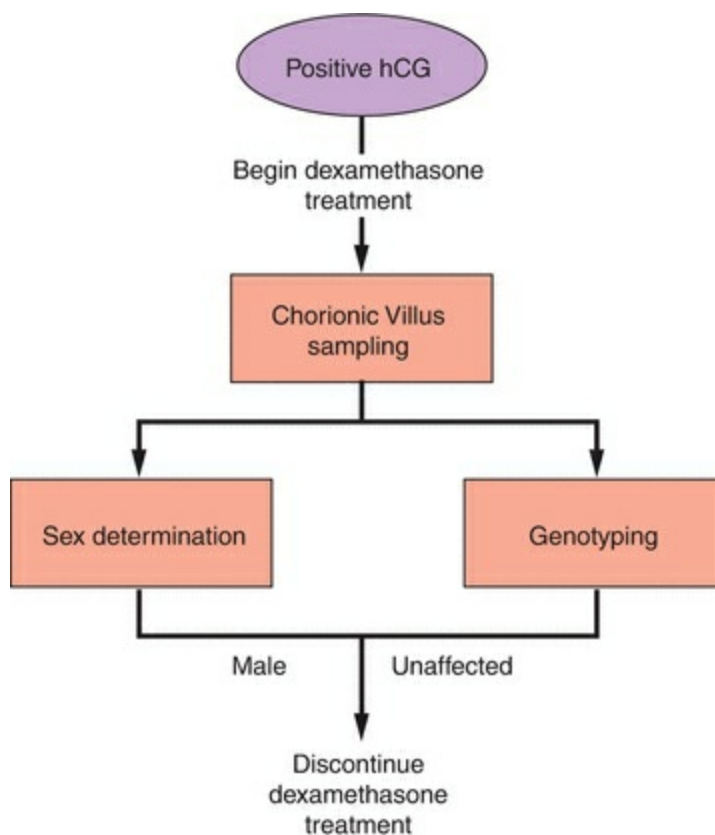
Polymerase chain reaction (PCR)-based genotyping has greatly improved genetic counseling of families with CAH. In couples at risk for conceiving an affected child, the technology also can be applied in preimplantation genetic testing for monogenic disorders (PGT-M, previously called preimplantation genetic diagnosis [PGD]) to detect affected embryos resulting from in vitro fertilization (IVF).<sup>226,227</sup> Previously, this technique was performed by removing a single cell from each embryo reaching the 6–8 cell stage on the 3rd day after oocyte retrieval and fertilization by intracytoplasmic sperm injection (ICSI), with transfer of an unaffected embryo(s) 2 days later at the blastocyst stage. However, following developments in blastocyst culture, day 5 trophoblast biopsy has become the preferred technique.<sup>228</sup> Although PGT-M requires IVF that otherwise would be unnecessary in fertile couples, some may prefer this option over others based on early prenatal diagnosis, as described below.

## Prenatal Treatment of Mothers at Risk for Having an Affected Child

Prenatal maternal treatment with dexamethasone (up to 1.5 mg daily in divided doses) can greatly decrease or prevent fetal female genital virilization.<sup>229</sup> Dexamethasone is not metabolized by the placenta and crosses effectively into the fetal circulation. **For maximum effectiveness, treatment should begin at 4–5 weeks of gestation and not later than 9 weeks.**<sup>148,229,230,231,232</sup> Prenatal maternal treatment poses some potential risks for the fetus, such as postnatal failure to thrive and psychomotor developmental delay, and also can have significant maternal side effects, including severe abdominal striae, hyperglycemia, hypertension, gastrointestinal symptoms, and emotional lability.<sup>232,233</sup>

**Given that only one in eight fetuses will benefit from maternal treatment (one in four affected, half of which will be males), the best approach involves early**

**prenatal diagnosis by CVS with rapid sex determination and genotyping, continuing or beginning treatment only in those mothers having an affected female fetus.** However, because even short-term prenatal treatment with dexamethasone may adversely affect postnatal physical, cognitive, and emotional development, careful pretreatment counseling, monitoring, and long-term follow-up are required and best provided in a research setting<sup>234,235</sup> (**Figure 8.9**).



**FIGURE 8.9**

## Neonatal Treatment

Newborn infants with classical CAH may be identified by prenatal diagnosis or neonatal screening or because they have genital ambiguity (females) or an adrenal crisis (males). Infants who exhibit signs of adrenal crisis (hypotension, hyponatremia, hyperkalemia, hypoglycemia, vomiting and diarrhea, weight loss, anorexia) require urgent medical treatment, focusing first on administration of fluids (10–20 mL/kg 0.9% saline) and correction of any significant hypoglycemia (2–4 mg/kg 10% dextrose); hyperkalemia should be corrected by administering glucose and insulin, if necessary. After a blood sample is obtained for measurement of steroid hormones (17-OHP primarily), a stress dose of hydrocortisone should be administered (50–100 mg/m<sup>2</sup>

intravenously, typically 25 mg), followed by 50–100 mg/m<sup>2</sup> daily in divided doses (every 4 hours). Additional stress doses of hydrocortisone are administered until the infant is stable and feeding normally. Immediate mineralocorticoid replacement is not necessary but will be required if a diagnosis of salt-wasting CAH is confirmed. Initially, doses of fludrocortisone up to 0.3 mg daily and sodium chloride supplementation (1–3 g daily; 17–51 mEq daily) are required.

In infants having a positive neonatal screening test for CAH, the diagnosis should be confirmed with a second blood sample for measurement of 17-OHP and electrolytes. While awaiting the results, electrolytes should be monitored closely if the infant is not treated empirically with glucocorticoids and mineralocorticoids. **Again, the urgent need is to identify infants with salt-wasting CAH before they develop adrenal crisis, which can occur anytime within the first few days or weeks after birth without treatment.**<sup>147,229</sup>

## Treatment in Children

Ideally, the medical, surgical, and psychological management of children with CAH should be guided by a multidisciplinary team, including pediatric endocrinologists, surgeons, urologists, geneticists, and psychologists.<sup>229</sup>

Children with classical or symptomatic nonclassical 21-hydroxylase deficiency require treatment with glucocorticoids.<sup>147,229,236</sup> **The goal of treatment is to promote normal growth and development by providing sufficient hormone to minimize adrenal sex steroid production while avoiding the consequences of glucocorticoid excess. Usually, that can be achieved by treatment with hydrocortisone (cortisol) in a dose of 12–18 mg/m<sup>2</sup> daily,**<sup>139,229,236</sup> which still exceeds normal daily cortisol secretion in children and adolescents (6–9 mg/m<sup>2</sup>/day).<sup>237,238,239</sup> Whereas long-acting glucocorticoids (e.g., prednisone, dexamethasone) also can be used, their longer duration of action and greater potency also increase the risk of overtreatment, which can adversely affect growth before closure of the epiphyses.<sup>148,240,241</sup> Normal growth has been observed in some studies of children treated with prednisone (approximately 1 mg/m<sup>2</sup>/day)<sup>242</sup> or dexamethasone (approximately 0.27 mg/m<sup>2</sup>/day),<sup>243</sup> but hydrocortisone remains the treatment of choice during childhood.<sup>229,236</sup>

**Mineralocorticoid treatment with fludrocortisone is required for children having classical 21-hydroxylase deficiency,** regardless whether they have the salt-wasting or simple virilizing form of the disorder. The goal of treatment is to maintain normal serum sodium and potassium concentrations while avoiding the consequences of overtreatment or undertreatment. Excessive mineralocorticoid treatment can cause hypertension and hypokalemia and may impair growth.<sup>244</sup> Inadequate treatment can

result in poor growth because it increases the glucocorticoid requirement<sup>244,245</sup> and may increase adrenal androgen production, because chronic volume depletion causes increased production of renin and angiotensin II, which can stimulate steroidogenesis.<sup>246</sup> In children, fludrocortisone is administered in a dose ranging between 0.05 and 0.2 mg daily.<sup>229</sup> Salt supplementation can be discontinued as the child begins to eat table food, but may be needed during hot weather or strenuous exercise.

The effectiveness of treatment generally should be monitored approximately every 3 months in infants and every 4–12 months in children,<sup>229</sup> by measuring the serum concentrations of 17-OHP, androstenedione, plasma rennin activity, growth velocity, and skeletal maturation, comparing results to normative data for age and sexual maturation.<sup>139</sup> Ideally, serum hormone measurements should be obtained in the morning when results will reflect peak concentrations.<sup>147,229,236</sup> **Serum 17-OHP levels generally should be maintained in a range between 400 and 1,200 ng/dL, but care must be taken to avoid undertreatment of hyperandrogenism and the consequences of iatrogenic hypercortisolism.**<sup>247</sup> Plasma rennin activity should be kept within the normal range for age by adjusting treatment with fludrocortisone and salt supplementation, before adjusting the level of glucocorticoid treatment. When necessary, a brief 7–10-day course of treatment with dexamethasone can effectively suppress high androstenedione levels that may result from poor compliance. Bone age and growth rate should be monitored every 6 months, with the goal of avoiding a decrease in growth and advanced bone age.<sup>248,249</sup> Patients with classical CAH have an increased risk for developing central precocious puberty due to poor control of adrenal androgen production; in those who do, treatment with a long-acting GnRH agonist may be needed.<sup>250</sup>

**Illness can precipitate adrenal crisis in children with classical CAH unless they receive adequate glucocorticoid treatment.** Signs and symptoms suggesting the possibility include hypotension, electrolyte imbalance (hyponatremia, hyperkalemia, hypoglycemia), and vomiting and diarrhea that sometimes can be accompanied by abdominal pain, fever, loss of appetite, and weight loss. In children with mild illness, the maintenance dose of glucocorticoid generally should be increased by two- to threefold. When illness is associated with diarrhea or vomiting and reduced oral intake, intravenous glucocorticoids, saline, and glucose may be required. In children with severe illness or who require major surgery, intravenous hydrocortisone should be administered in a dose appropriate for age; for those 12 years of age or older, a one-time dose of 100 mg should be administered, followed by 100 mg/day. During recovery, stress doses of hydrocortisone can be gradually decreased, by approximately 50% per day.<sup>229</sup>

**Children with classical CAH are at increased risk for early puberty and short stature because high levels of sex steroids promote premature epiphyseal closure.** In treated patients with classical CAH, adult height usually is lower than in reference populations, by an average of approximately 10 cm, independent of the level of control of adrenal androgen concentrations, which suggests that treatment with exogenous glucocorticoids also suppresses growth.<sup>251,252</sup> The effectiveness of treatment during the first 2 years of life and during puberty appears to have the most important influence on final height.<sup>253,254,255</sup> Treatment with growth hormone and a long-acting GnRH agonist can help to maximize growth and adult height.<sup>256,257</sup> Obesity is a common complication of glucocorticoid treatment in children with classical CAH; body mass index correlates with the dose of prescribed medication.<sup>258</sup> In obese children, the incidence of hypertension also is increased.<sup>259</sup>

The surgical management of the genital abnormalities in virilized female children with classical CAH is quite complicated. Traditionally, surgery has been performed in the first few years of life, when the child is still too young to remember the procedure, to avoid any psychological problems associated with having abnormal external genitalia. **However, the wisdom and outcomes achieved with early surgery recently have been challenged, and many now advocate delaying unnecessary surgery until the child is older and can participate in the decision.**<sup>115</sup> The controversy is discussed in a later section of this chapter devoted to the management of ambiguous genitalia. If clitoroplasty is performed, the clitoral recession procedure, conserving the glans and its innervation, should be employed. It is important to know that women who undergo clitoroplasty and even total clitoral amputation generally do not have an impaired erotic response or decreased capacity for orgasm. When necessary, vaginal reconstruction is best postponed until after puberty when mature compliance is possible. In patients with severe classical CAH, bilateral adrenalectomy offers the potential advantage of preventing adrenal hyperandrogenism, but also increases the risk for developing adrenal crisis.<sup>260,261,262</sup>

## Treatment in Adults

For older adolescent and adult women with classical CAH, the goal of treatment is to lower and maintain serum concentrations of adrenal precursors (17-OHP) and androgens to the upper limits for normal women. **After epiphyseal closure is complete, treatment with long-acting glucocorticoids (e.g., dexamethasone, prednisone) generally is preferred.** When administered at bedtime in a dose ranging between 0.25 and 0.75 mg, ACTH is effectively suppressed for most or all of the following day. Bedtime treatment effectively inhibits the peak of ACTH secretion, which occurs between 2:00 A.M. and 10:00 A.M.<sup>240</sup> **To avoid the risks of osteoporosis and**



**developing Cushing syndrome, dosage must be adjusted to the needs of the individual patient.** Alternative treatment regimens include prednisone (median dose 7 mg/day; range 4–10 mg/day) or single or divided doses of hydrocortisone (median 30 mg/day; range 15–40 mg/day).<sup>263</sup> Supplemental doses of glucocorticoid, generally involving a two- to threefold increase in the usual daily dose, are indicated during times of stress such as febrile illness, surgery, and trauma; normal exercise does not require stress doses of glucocorticoids.<sup>236</sup>

**As in children with classical CAH, mineralocorticoid treatment in adults is provided with fludrocortisone,** in the dose required to maintain normal serum sodium and potassium concentrations and plasma renin activity, usually ranging between 0.1 and 0.2 mg/day. When mineralocorticoid treatment is optimized, the dose of glucocorticoids can be minimized.<sup>244,245</sup> Inadequate treatment can result in chronic volume depletion that promotes excess production of renin and angiotensin II, which, in turn, can stimulate increased adrenal androgen synthesis.<sup>246</sup> Patients with the simple virilizing form of classical CAH who exhibit increased plasma renin activity and aldosterone concentrations can benefit from mineralocorticoid treatment, which helps in controlling 17-OHP levels.<sup>264,265</sup>

**Treatment should be monitored by periodic measurements of bone density, and serum 17-OHP, DHEA-S, androstenedione, and testosterone concentrations, remaining alert to the development of signs or symptoms of Cushing syndrome. In those who require mineralocorticoid treatment, plasma renin activity should be monitored and maintained near the upper limit of normal.**

Many women with classical CAH who underwent reconstructive surgery during childhood later require further reconstructive surgery during late adolescence or early adulthood, generally involving clitoroplasty and vaginoplasty. Approximately half of procedures performed during infancy will require later revision.<sup>139,266</sup>

Psychological counseling, ideally beginning soon after the diagnosis is established, is an important part of the treatment of classical CAH. Although data are limited and conflicting, the incidence of adult psychiatric disorders may be increased in women with classical CAH.<sup>267,268</sup> Sexual relationships may develop somewhat later than usual and sexual function may not be completely normal, even in those having had reconstructive surgery.<sup>5</sup>

## **Treatment During Pregnancy**

Although normal reproduction is possible with effective treatment, fertility generally is decreased in women with classical CAH, particularly in those with the salt-wasting variety of the disorder, due to chronic anovulation and, in some cases, due to poor

surgical results.<sup>3</sup> **In those who do conceive, serum concentrations of androstenedione, testosterone, and 17-OHP should be carefully monitored and the dosage of glucocorticoids increased as needed to maintain normal levels for gestational age. Treatment with long-acting glucocorticoids should be discontinued in favor of treatment with hydrocortisone, which is metabolized by the placenta and thereby avoids the risk of suppressing the fetal hypothalamic-pituitary-adrenal axis.** In general, term pregnancies, delivery of healthy female infants with normal external genitalia, and normal growth and development in both girls and boys can be achieved.<sup>180,269</sup> Even when maternal androgen levels cannot be suppressed to normal, the high capacity of placental aromatase activity effectively protects the fetal female genitalia.<sup>180</sup>

The incidence of cesarean delivery is increased, primarily because of concerns that vaginal delivery may disrupt a previous surgical reconstruction of perineal anatomy. An android pelvis is no more common than usual, because the form and size of the adult pelvis are determined during the pubertal growth spurt. However, a small pelvis might result if bone age is advanced to age 13–14 before treatment started. **The need for stress doses of glucocorticoids during labor and delivery is obvious and does not increase the risk for infection or poor wound healing.**

## **Androgen Excess—Fetoplacental Origin**

Two rare enzyme deficiencies associated with androgen excess—aromatase deficiency and P450 oxidoreductase deficiency—are distinct from those causing classical forms of CAH because they involve both the fetal adrenal and the placenta.

### **Aromatase (P450arom) Deficiency**

The enzyme aromatase (also designated P450arom and CYP19A1) catalyzes the conversion of 19-carbon androgens (androstenedione, testosterone, 16 $\alpha$ -hydroxy DHEA) to aromatic 18-carbon estrogens (estrone, estradiol, and estriol, respectively) and is encoded by the CYP19A1 gene, located on chromosome 15 (15p21.1). The enzyme is active in the gonads, the placenta, the brain, and in adipose; tissue-specific regulation is controlled, in part, by alternative tissue-specific promoters. Aromatase deficiency is a rare autosomal recessive disorder caused by mutations in the CYP19A1 gene. As a consequence, fetal androgens are not converted to estrogens in the placenta, resulting in female fetal virilization (due to the accumulation of fetal androgens), low maternal serum estrogen levels, and maternal hirsutism, which typically develops during the second half of pregnancy and regresses after delivery. **Affected females classically present with ambiguous genitalia at birth and, at puberty, exhibit signs of hyperandrogenism, absent breast development, primary amenorrhea associated**

**with hypergonadotropic hypogonadism, and multicystic ovaries.**<sup>270,271,272,273</sup>  
Aromatase mutations also can produce variable or nonclassic phenotypes characterized by varying degrees of breast development.<sup>274</sup>

## **P450 Oxidoreductase Deficiency**

The classical forms of CAH all are caused by mutations in genes encoding steroidogenic enzymes, resulting in reduced or absent enzyme activity, and in clinical signs and symptoms caused by the accumulation of steroid precursors and/or decreased production of the principal steroid end product. Another newly described form of CAH results from a deficiency in the P450 oxidoreductase (POR) enzyme. Although not a steroidogenic enzyme per se, POR nonetheless affects several steroidogenic pathways and now is recognized as a cause of both 46,XX DSD (female virilization) and 46,XY DSD (incomplete male virilization), which is discussed below.<sup>275</sup>

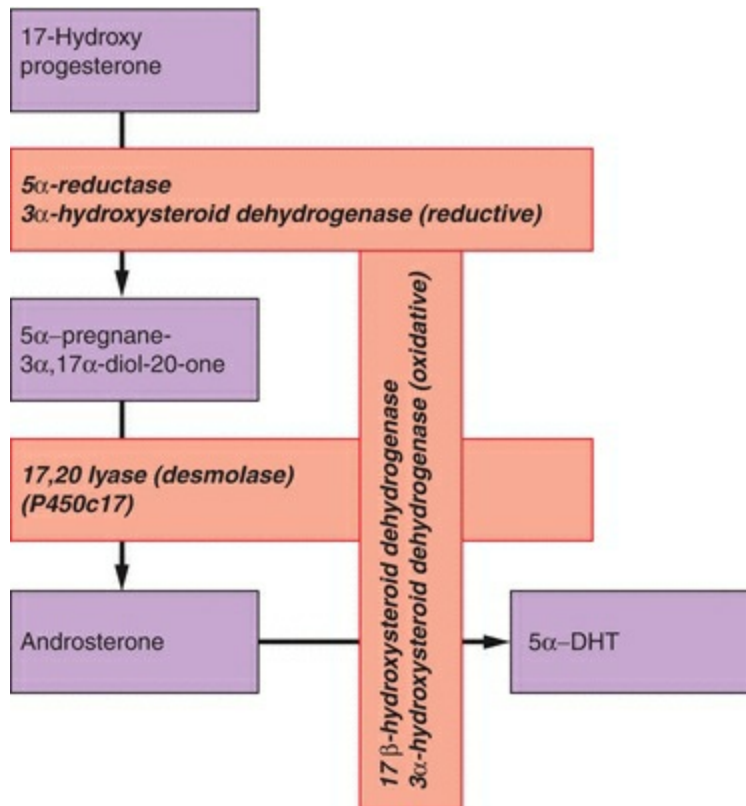
First described in 2004,<sup>276</sup> POR deficiency is perhaps the most complex form of CAH because it affects the activity of all of the P450 enzymes involved in steroidogenesis, to varying degrees, resulting in varying patterns of abnormal steroid hormone production and a spectrum of clinical manifestations, and has other “nonendocrine” effects on skeletal development and drug metabolism. POR is a flavoprotein associated with the endoplasmic reticulum and is encoded by the POR gene, located on chromosome 7 (7q11.2). POR serves as the electron donor in the activation of all microsomal P450 enzymes, including P450c21 (the adrenal 21-hydroxylase, CYP21A2), P450c17 (CYP17A1, which catalyzes both 17 $\alpha$ -hydroxylase and 17,20-lyase activities), and P450arom (aromatase, CYP19A1, which mediates the conversion of androgens to estrogens). POR deficiency is an autosomal recessive disorder and more than 25 different POR mutations already have been identified, most being missense mutations in the central electron transfer domain of the protein.<sup>275,277</sup>

Patients with the same mutation, even siblings, can exhibit phenotypic differences, but the hormonal profile of all patients with POR mutations reflects partial deficiencies of 21-hydroxylase and 17 $\alpha$ -hydroxylase/17,20-lyase. Because 21-hydroxylase and 17,20-lyase activities are impaired to a greater degree than 17 $\alpha$ -hydroxylase activity, basal serum 17-OHP concentrations are elevated and exhibit an exaggerated response to ACTH stimulation (due to impaired 21-hydroxylase activity), and levels of DHEA/DHEA-S and androstenedione are low (due to impaired 17,20-lyase activity). Basal cortisol levels usually are normal or near normal, but do not rise normally with ACTH stimulation, revealing a chronically compensated adrenal insufficiency<sup>275</sup> (Table 8.2).

**TABLE 8.2 Hormone Profile Associated with P450  
Oxidoreductase Deficiency**

Hormone	Basal Level	ACTH-stimulated Response
17-OHP	High	Exaggerated
DHEA/DHEA-S	Low	Low
Androstenedione	Low	Low
Cortisol	Normal	Low

Surprisingly, females with POR deficiency frequently become virilized in utero, something not expected, given that fetal adrenal androgen production should be decreased, not increased. There are two hypotheses concerning the source of androgen excess that might explain the apparent dichotomy, but neither has been established conclusively.<sup>278,279,280</sup> The first envisions that even the modest amount of androgens produced could accumulate due to the deficiency of placental P450arom in patients with POR deficiency. The second invokes an alternative “backdoor pathway” to androgen production in which elevated levels of 17-OHP, which cannot be efficiently metabolized via P450c21 or P450c17 activities, seek alternative metabolism via 5 $\alpha$ -reduction and ultimately are converted to DHT, circumventing the usual pathway via androstenedione and testosterone (“Backdoor pathway” of androgen production is shown in **Figure 8.10**).<sup>279,280,281</sup> Although the backdoor pathway still involves P450c17, the enzyme’s affinity for its substrate in the alternative pathway (5 $\alpha$ -pregnane-3 $\alpha$ , 17 $\alpha$ -diol-20-one) is much higher than for 17-OHP. Therefore, the backdoor pathway likely functions better than the conventional metabolic pathway in patients with POR deficiency.<sup>281</sup>



**FIGURE 8.10**

The phenotype of POR deficiency varies widely. Whereas some exhibit a characteristic spectrum of skeletal abnormalities known as the Antley-Bixler syndrome (craniosynostosis, midface hypoplasia, choanal atresia or stenosis, radiohumeral and/or radioulnar synostosis, femoral bowing and fractures, and joint contractures), indistinguishable from that observed in patients with mutations in the fibroblast growth factor receptor-2 gene (FGFR2), bony abnormalities are subtle or altogether absent in others.<sup>275</sup> The phenotypic spectrum in patients with proven POR deficiency has included asymptomatic patients identified by neonatal screening for 21-hydroxylase deficiency, asymptomatic patients whose mothers virilized during pregnancy, virilized female infants, and an adult female with primary amenorrhea and multicystic ovaries.<sup>276,278,281,282</sup> The widely varying phenotype has led to speculation that POR deficiency may be relatively common and frequently goes unrecognized or is misdiagnosed.

Diagnosis of POR deficiency is not straightforward. The diagnosis should be considered in the evaluation of children with sexual ambiguity and when prenatal screening for trisomy 21 reveals low maternal estriol levels. Mutation analysis is indicated for patients who exhibit compatible steroid hormone profiles.

## **Androgen Excess—Maternal Origin (Gestational Hyperandrogenism)**

Maternal gestational hyperandrogenism is another, albeit very uncommon, cause of fetal virilization and may result from maternal ingestion of androgens or drugs having androgenic actions or from excess maternal androgen production. The possibility should be considered when a pregnant woman exhibits a rapid onset of masculinizing signs, including hirsutism, temporal balding, clitoromegaly, and deepening of the voice. It also should be considered after delivery of a virilized female infant, remembering that luteomas and theca-lutein cysts regress after delivery.

**The possible or probable extent of fetal virilization relates to the time of exposure to maternal androgens. Whereas exposure during early pregnancy can cause labioscrotal fusion and clitoromegaly, exposure after 12 weeks of gestation causes only clitoral hypertrophy.**

### **Drug Ingestion**

Most cases of female fetal virilization resulting from maternal drug ingestion have involved treatment with danazol for endometriosis<sup>283</sup> or with progestins for threatened or recurrent abortion.<sup>284,285</sup> **The risk appears limited to progestins that bind to the androgen receptor.**<sup>286</sup> Given their potential risks, progestational agents other than progesterone or 17-hydroxyprogesterone are no longer administered to pregnant women. **However, virilization of female infants has not been observed in women exposed to oral contraceptives after conception.**<sup>287</sup> Maternal ingestion of androgens also can cause fetal virilization, but often does not, probably because fetal exposure is limited by the high capacity of placental aromatase activity.

### **Excess Androgen Production**

Women who develop gestational hyperandrogenism merit a thorough evaluation.<sup>288</sup> Luteomas and theca-lutein cysts are the most common causes; virilizing ovarian or adrenal tumors are rarely encountered during pregnancy.<sup>289,290,291,292,293,294,295</sup> However, all diagnostic possibilities warrant consideration.

Pelvic ultrasonography is helpful for distinguishing between adrenal and ovarian tumors, solid and cystic ovarian masses, and unilateral from bilateral ovarian disease. Approximately one-half of luteomas and almost all theca-lutein cysts are bilateral<sup>296</sup>; other ovarian tumors usually are unilateral. Malignant tumors are most likely to be solid and unilateral. Serum hormone measurements have limited diagnostic value, given that maternal serum testosterone concentrations normally rise progressively during

pregnancy, primarily due to the marked increase in sex hormone-binding globulin (SHBG) levels. **Surgery is rarely needed for women with luteomas or theca-lutein cysts because both characteristically regress after delivery.** However, when a tumor is highly suspected and cannot be excluded, laparoscopy or laparotomy may be required to establish the correct diagnosis.

## Pregnancy Luteoma

Pregnancy luteomas are hyperplastic masses of luteinized cells and not true tumors. Their true incidence is unknown and most likely go unrecognized because they produce little androgen or have little or no significant androgenic effect. Luteomas may be discovered incidentally at the time of cesarean delivery or other abdominal surgery during pregnancy or the early puerperium or when they are large or cause maternal virilization. Typically, luteomas are solid masses ranging between 6 and 10 cm in size; in approximately half of cases, they are bilateral.<sup>297,298</sup>

In women with luteomas, serum concentrations of androstenedione, testosterone, and DH are increased, sometimes dramatically.<sup>288,297,299</sup> However, only approximately one-third of reported pregnancy luteomas have been associated with maternal hirsutism or virilization,<sup>288,300</sup> probably because any increase in serum free testosterone is limited by the large increase in SHBG levels that occurs during pregnancy. **There is essentially no risk that the female fetus of a woman with a luteoma will become virilized if the mother herself does not.** However, approximately 80% of female infants born to virilized mothers also are virilized, to an extent that correlates with the severity, duration, and, most importantly, the stage of pregnancy at the time of androgen exposure.<sup>301,302</sup>

The typically prompt regression of luteomas after delivery suggests that hCG may play some role in stimulating or perpetuating androgen production in luteomas.<sup>303</sup> However, most luteomas are identified late in gestation, long after the peak in maternal serum hCG concentrations. Moreover, theca-lutein cysts, rather than luteomas, are more commonly associated with excessively high hCG levels, as observed in women with gestational trophoblastic disease. Consequently, it seems likely that some other mechanism is responsible for the growth and androgen production of luteomas in late gestation.

## Theca-Lutein Cysts

Clinically apparent theca-lutein cysts, also known as hyperreactio luteinalis, develop most frequently in women with multiple pregnancies, isoimmunized mothers, those with molar pregnancies or gestational trophoblastic disease, and women with diabetes mellitus, all of which are associated with increased maternal serum hCG



concentrations; the highest incidence (10–20%) is observed in women with trophoblastic disease.<sup>304</sup> However, not all women with such conditions develop theca-lutein cysts, which also may persist long after evacuation of molar pregnancies despite the rapid decrease in serum hCG levels.<sup>304,305,306</sup> Rarely, mothers with pre-existing hirsutism related to polycystic ovary syndrome or ovarian stromal hyperthecosis may develop theca-lutein cysts and gestational hyperandrogenism.<sup>307,308</sup>

Ovaries containing theca-lutein cysts can become quite enlarged, reaching 10–15 cm in diameter. Histologically, the ovarian cortex usually exhibits focal hyalinization. **Approximately 30% of pregnant women with clinically apparent theca-lutein cysts become hirsute or virilize.**<sup>288,309,310,311</sup> In most of those who exhibit virilization, serum concentrations of testosterone and androstenedione are elevated; cord serum testosterone levels also may be elevated in their infants,<sup>309,310,312,313</sup> but no cases of virilized female infants have been reported.

## Other Disorders of Genital Development

There is a last group of 46,XX DSD that cannot yet be classified by cause, because their causes are unknown. The category includes cloacal exstrophy, müllerian agenesis, and the syndrome of müllerian, renal, and cervicothoracic somite dysplasia known as the MURCS association.

### Cloacal Exstrophy

Cloacal exstrophy is a rare and complex anorectal and genitourinary malformation in which the rectum, vagina, and urinary tract share a common everted orifice, accompanied by an omphalocele, and an imperforate anus. Typically, the bladder and genitalia are divided into two halves on either side of an exposed segment of bowel; a number of variants have been described.<sup>314</sup> The disorder is believed to result from the failed migration of the lateral mesodermal folds of the infraumbilical anterior abdominal wall, leading to an enlarged cloacal membrane that ruptures prematurely, before descent of the urorectal septum, sometime prior to 8 weeks of gestation.<sup>314,315</sup>

### Müllerian Agenesis (Mayer-Rokitansky-Küster-Hauser Syndrome)

**Müllerian agenesis is a disorder of genital development characterized by absence of the vagina, an absent or hypoplastic uterus, and normal or hypoplastic fallopian tubes.**<sup>316</sup> The disorder is a relatively common cause of primary amenorrhea and is described in detail in [Chapter 10](#) (Amenorrhea). Typically, the ovaries are entirely normal, although one or both also may be undescended, hypoplastic, or associated with an inguinal hernia. Affected patients often also have urologic anomalies (unilateral renal

agenesis, ectopic or horseshoe kidney, and duplication of the collecting systems) and skeletal malformations (e.g., hemiverterbrae and scoliosis or the Klippel-Feil syndrome, which includes a short neck, low hairline, limited range of motion, and neurologic symptoms, resulting from one or more fused vertebrae).<sup>317,318</sup> The cause is unknown, although some cases are associated with chromosomal translocations or occur in familial aggregates, suggesting a genetic basis. Logically, müllerian agenesis might be attributed to an activating mutation in the gene encoding AMH or its receptor, causing excess AMH activity, but none have been identified.<sup>319</sup>

**Patients with müllerian agenesis typically present in late adolescence or as young adults with primary amenorrhea, exhibiting normal breast and pubic hair development and no visible vagina.** A few may have functional islands of endometrium, resulting in obstructed menses and symptoms of cyclic pain.<sup>317,318</sup> Evaluation should include a karyotype, renal ultrasonography, spinal x-rays, and pelvic ultrasonography or MRI when there is reason to suspect a functional uterine remnant.<sup>320,321</sup> Surgery generally is indicated only for those with symptoms relating to hematometra, endometriosis, or an inguinal hernia. When the time is appropriate, a functional vagina can be created by progressive vaginal dilation,<sup>322,323,324</sup> traditional vaginoplasty,<sup>325</sup> or the modified Vecchiotti operation, which is performed laparoscopically.<sup>326,327</sup> Women with müllerian agenesis are infertile but can expect normal sexual function and have their own genetic offspring via IVF using oocytes retrieved from their own normal ovaries and their partner's sperms, with subsequent transfer of embryos to a gestational surrogate.<sup>328,329</sup> While still experimental, uterine transplantation has become an option for patients with MRKH to carry their own pregnancy since the first report of successful live birth following uterine transplant in 2015.<sup>330</sup> To date, approximately 40 live and deceased donor uterine transplants have been performed with numerous live births using IVF. Additional optimization is ongoing with use of utero-ovarian vein pedicles in live donor procedures and minimizing cold ischemia time in deceased donors. Consequently, uterine transplantation is likely to become a more prevalent and accepted treatment.<sup>331</sup>

## **Müllerian Renal Cervicothoracic Somite Dysplasia (The MURCS Association)**

The MURCS association is a syndrome characterized by müllerian (MU) aplasia or hypoplasia, unilateral renal (R) agenesis or ectopy and cervicothoracic somite (CS) dysplasia, which results in vertebral defects (e.g., Klippel-Feil anomaly, scoliosis), and abnormalities of the ribs, upper limbs, and scapula.<sup>332</sup> Other associated anomalies have included cleft lip and palate, ovarian agenesis, abnormal pulmonary fissures, tetralogy

of Fallot, anorectal malformations, and transmissive deafness.<sup>333,334,335,336</sup> The pathophysiology involved is unclear but logically may involve an event occurring very early in development when the blastemas of the pronephric buds and cervicothoracic buds are closely located. The disorder has similarities to the 22q11 deletion syndrome (aortic arch anomalies, facial deformities, nasal voice, mild learning difficulties, renal agenesis, autoimmune disease, and cervical spine anomalies) and to the Mayer-Rokitansky-Küster-Hauser syndrome, suggesting a similar pathophysiology.<sup>332,337</sup>

# 46,XY Disorders of Sexual Development

DSD occurring in chromosomal males (46,XY) can result from abnormalities in gonadal development, from decreased fetal androgen synthesis relating to deficiencies of steroidogenic enzymes or regulatory proteins, from androgen receptor defects that prevent normal androgen action, from LH receptor defects causing Leydig cell hypoplasia, or from mutations affecting AMH or its receptor.

## Disorders of Gonadal (Testicular) Development

Normal gonadal development requires normal germ cells and normal gonadal somatic cells. Disorders of testicular development include complete gonadal dysgenesis (Swyer syndrome), partial gonadal dysgenesis (a variety of single-gene disorders and chromosomal abnormalities involving key genes), and the loss of otherwise normally developed testes during fetal life (testicular regression syndrome). In addition, a small proportion of patients with ovotesticular DSD (discussed in an earlier section of this chapter) has a 46,XY karyotype.

### Complete Gonadal Dysgenesis (Swyer Syndrome)

Swyer syndrome is an uncommon form of gonadal dysgenesis, characterized by a 46,XY karyotype.<sup>338</sup> **Despite the presence of a Y chromosome, the phenotype is female because the dysgenetic (streak) gonads produce neither AMH nor androgens.** Consequently, the vagina, cervix, uterus, and fallopian tubes develop normally and the internal and external genitalia do not masculinize.<sup>339</sup> **In approximately 10–15% of patients, the disorder results from an inactivating mutation in the SRY gene, but in most, no cause can be identified.**<sup>340</sup> Mutations in other genes involved in the regulation of SRY expression or encoding important downstream elements in the testis-determining pathway have been implicated.<sup>341,342,343</sup>

**Patients with Swyer syndrome generally present after the expected time of puberty with delayed sexual maturation, primary amenorrhea, normal pubic hair, and normal female internal and external genital anatomy.** Evaluation reveals hypergonadotropic hypogonadism, prompting a karyotype that establishes the diagnosis. **Gonadectomy is indicated soon after diagnosis due the significant risk for development of germ cell tumors in occult testicular elements (20–30%).**<sup>344</sup>

**Sex of assignment and rearing and gender identify is unequivocally female, and no specific treatment is required other than estrogen therapy to induce breast development and, subsequently, estrogen and progestin therapy (cyclic or combined) to maintain sexual maturation. Pregnancy can be achieved with IVF**

using donor oocytes and has not been associated with any specific risks or complications.<sup>345</sup>

## **Partial Gonadal Dysgenesis**

Partial gonadal dysgenesis describes a group of disorders resulting from a wide assortment of genetic mutations causing abnormal gonadal development and function. In affected patients, müllerian structures may be present or absent, the external genitalia may be female, ambiguous, or male, and the phenotype can include developmental abnormalities outside of the reproductive tract. The wide variations in phenotype reflect the many different actions of the gene products, which are involved in the regulation of SRY expression, müllerian regression, testis differentiation, and developmental patterning. Examples include single-gene disorders involving WT1, SF1, SRY, SOX9, DHH (an intercellular signaling molecule having an important role in morphogenesis and testis development), ATRX (a transcriptional regulator expressed during development), and ARX (a homeobox-containing gene expressed during development), as well as chromosomal aberrations involving key genes such as a DMRT1 (hemizyosity), DAX1 (duplication), and WNT4 (duplication)<sup>115,346,347</sup> (Table 8.3).

## **TABLE 8.3 Genes Associated with 46,XY Partial Gonadal Dysgenesis**

Gene	Locus	Inheritance	Gonad	Müllerian Structures	External Genitalia	Associated Features
<b>Single-gene disorders</b>						
<i>WT1</i>	11p13	Autosomal dominant	Dysgenetic testis	+/-	Female or ambiguous	Wilms tumor, renal anomalies, gonadal tumors
<i>SFI</i>	9q33	Autosomal dominant/recessive	Dysgenetic testis	+/-	Female or ambiguous	Adrenal failure (some)
<i>SRY</i>	Yp11.3	Y	Dysgenetic testis/ovotestis	+/-	Female or ambiguous	
<i>SOX9</i>	17q24-5	Autosomal dominant	Dysgenetic testis/ovotestis	+/-	Female or ambiguous	Campomelic dysplasia
<i>DHH</i>	12q13.1	Autosomal recessive	Dysgenetic testis	+	Female	
<i>ATRX</i>	Xq13.3	X	Dysgenetic testis	-	Female, ambiguous, or male	Alpha thalassemia, mental retardation
<i>ARX</i>	Xp22.13	X	Dysgenetic testis	-	Ambiguous	Lissencephaly, epilepsy, temperature instability
<b>Chromosomal aberrations</b>						
<i>DMRT1</i>	9p24.3	Hemizyosity	Dysgenetic testis	+/-	Female or ambiguous	Mental retardation
<i>DAX1</i>	Xp21.3	Duplication Xp21	Dysgenetic testis or ovary	+/-	Female or ambiguous	
<i>WNT4</i>	1p35	Duplication 1p35	Dysgenetic testis	+	Ambiguous	Mental retardation

Data from Lee PA, Houk CP, Ahmed SF, Hughes IA, Consensus statement on management of intersex disorders. International Consensus Conference on Intersex, Pediatrics 118:e488, 2006.

## Testicular Regression Syndrome

Testicular regression syndrome is a condition in which a developmentally normal testis existed during fetal life but subsequently regressed or was lost. **The disorder can be unilateral or bilateral and is characterized by partial or complete absence of testicular tissue in the presence of normal male external genitalia.**<sup>348</sup> Typically, the vas and associated vessels end blindly with a varying amount of testicular tissue remaining. The natural history of the disorder is poorly understood. Current concepts presume normal early embryonic development and testicular descent, followed by a catastrophic event such as torsion. If the process occurs relatively late in pregnancy, the internal and external genitalia virilize and the müllerian ducts regress normally, but the testes are absent at birth (anorchia). However, earlier loss of both testes can result in a small phallus or incomplete masculinization.<sup>349</sup>

In histopathologic studies of atretic nodular testicular remnants obtained from

affected neonates or young boys, only 10% of specimens have contained any identifiable seminiferous tubules, which consisted mainly of Sertoli cells enveloped in fibrous strands with no visible germ cells.<sup>348</sup> Hemosiderin-laden macrophages, generally a late cellular response to tissue damage, are present in approximately two-thirds of cases and, occasionally, a vas and epididymis can be observed.<sup>348,350,351</sup>

## Disorders of Androgen Synthesis

A number of steroidogenic enzymes and regulatory proteins are involved in androgen synthesis, and a deficiency in any one of them can result in decreased fetal androgen production and its consequences. All are rare, but each is a recognized cause of 46,XY DSD; together, they account for less than 5% of cases. Disorders of testosterone synthesis usually impair virilization of the external genitalia to a greater extent than the internal genitalia.

### Steroid 5 $\alpha$ -Reductase Deficiency

**Steroid 5 $\alpha$ -reductase (type 2) deficiency is an autosomal recessive disorder characterized by a 46,XY karyotype and severe perineal hypospadias (describing a genital configuration consisting of a phallus midway in size between penis and clitoris, a chordee tethering the phallus to the perineum, a urethral opening usually on the perineum, and an incompletely closed urogenital opening resembling a small and shallow vagina), which results from impaired virilization during embryogenesis due to defective conversion of testosterone to dihydrotestosterone (DHT).**<sup>352,353,354</sup>

In the classical presentation, the external genitalia are predominantly female at birth, exhibiting failed fusion of the labioscrotal folds and a urogenital sinus or separate urethral and vaginal openings, with or without clitoromegaly. The internal genitalia are male; the epididymides, vasa deferentia, seminal vesicles, and ejaculatory ducts form, but empty into a shortened, blind vagina. In some, the wolffian duct derivatives end on the perineum, on either side of the urethra. The testes are located in the inguinal canals, in the labia majora, or in the scrotum and exhibit impaired spermatogenesis. **The distinguishing feature of the disorder is that affected individuals virilize, to varying degrees, at the time of puberty.** Unlike in disorders relating to abnormalities in the androgen receptor, breast development in men with steroid 5 $\alpha$ -reductase is like that in normal males. Although a few individuals with 5 $\alpha$ -reductase deficiency are sufficiently virilized to be assigned a male gender at birth,<sup>355</sup> most have been reared as females and assumed a male gender and behavior at the time of puberty.<sup>356</sup>

The clinical features of steroid 5 $\alpha$ -reductase deficiency again illustrate the mechanisms involved in phenotypic sexual differentiation.<sup>357</sup> The wolffian duct

derivatives (the ejaculatory ducts, epididymides, vasa deferentia, and seminal vesicles) form normally, in response to normal fetal testosterone levels, but the genital structures that derive from the urogenital sinus and genital tubercle (the external genitalia, urethra, and prostate) do not virilize normally, because they are dependent on the intracellular conversion of testosterone to DHT. Affected men develop a normal muscle mass, libido, and deepening of the voice, which result from the actions of testosterone, but have less body hair and less temporal hairline recession, and no problems with acne, all of which result primarily from the actions of DHT. The unique importance of DHT during fetal development is demonstrated by the significant genital virilization that occurs after puberty.<sup>358</sup>

There are two types of steroid 5 $\alpha$ -reductase, designated types 1 and 2,<sup>359</sup> encoded by two separate genes; the gene encoding the type I enzyme (RD5A1) is located on chromosome 5 (5p15) and that encoding the type 2 enzyme (RD5A2) is located on chromosome 2 (2p23). In those with the disorder recognized as steroid 5 $\alpha$ -reductase deficiency, the type 2 enzyme is defective and the type 1 enzyme is normal.<sup>360</sup> **The resulting impaired conversion of testosterone to DHT prevents normal virilization of the male external genitalia during fetal development.** Affected individuals typically have very low but measurable serum DHT concentrations, which could reflect limited activity of the abnormal enzyme but more likely results from the actions of the type 1 enzyme.<sup>355</sup> The virilization that occurs at puberty may be driven by serum DHT or by testosterone itself. Transient gynecomastia may develop at puberty but does not persist, because androgen and estrogen production is like that in normal adult men.

A wide variety of RD5A2 mutations has been described, most being point mutations that yield a low concentration of enzyme, an unstable enzyme having reduced activity, or an enzyme with decreased affinity for testosterone and/or essential cofactors. Approximately 40% of affected individuals are homozygous for the same mutation, the remainder being compound heterozygotes.<sup>360</sup> Nearly half have similarly affected family members, likely reflecting consanguinity and a founder effect.<sup>361</sup> In women, mutations are essentially silent; although body hair may be reduced and menarche delayed, even those with homozygous mutations are phenotypically normal and have normal menstrual function and fertility.<sup>362,363</sup>

**The diagnosis of 5 $\alpha$ -reductase deficiency should be suspected in infants with genital ambiguity and in adolescents or young adults having the characteristic phenotype and serum hormone profile (a normal male serum testosterone concentration and an increased testosterone/DHT ratio), which typically exceeds 10 in infants and often exceeds 20 in older children and adults.**<sup>354,364</sup> In infants and prepubertal children, basal testosterone and DHT levels may not be sufficient for diagnosis and are best evaluated by performing an hCG stimulation test, measuring



testosterone and DHT before (basal, day 1) and after (stimulated, days 3 and 6) administering exogenous hCG (1,500 IU/m<sup>2</sup> on days 1 and 3).<sup>364,365,366</sup> Individuals with 5 $\alpha$ -reductase deficiency can be distinguished from those having defects of testosterone synthesis by their normal or elevated serum testosterone levels and from those with incomplete androgen insensitivity by demonstrating normal ratios of 5 $\beta$ - to 5 $\alpha$ -reduced glucocorticoid metabolites, as indicators of hepatic steroid metabolism.<sup>367</sup> A definitive diagnosis can be established by analyzing DNA extracted from blood or tissue.<sup>360</sup>

The management of patients with steroid 5 $\alpha$ -reductase deficiency is complicated because half or more initially assigned as females undergo a change in gender identity and behavior in later life.<sup>356</sup> The sex of rearing, the age of the subject, and the gender identity influence the choice of management. The decision to raise an individual as female should be made only after thorough psychological evaluation to confirm a female gender identity, but once made, management is relatively straightforward. Gonadectomy should be performed to prevent later virilization and tumor development in cryptorchid testes.<sup>368</sup> Any clitoromegaly can be surgically corrected, taking care to maintain the glans clitoris. If required, a functional vagina can be established by progressive vaginal dilation<sup>323,324,369</sup> or by surgical vaginoplasty.<sup>370</sup> Estrogen treatment to induce and maintain feminine characteristics should be started at the usual time of puberty or immediately after gonadectomy in adults.

The decision to raise an individual as male is no less complex and also will involve surgical and medical treatment. The timing of surgery to correct the hypospadias and cryptorchidism depends on the degree of hypospadias and the size of the phallus. Unfortunately, the extent of virilization at puberty usually is less than desired,<sup>364,371</sup> prompting efforts to improve results by treatment with exogenous testosterone or DHT. Treatment with testosterone before puberty can help to enlarge the phallus.<sup>364</sup> Treatment with DHT can raise serum DHT concentrations, but must be specially prepared as there is no commercially available preparation.<sup>372,373</sup> Although sperm counts are quite low in most patients,<sup>374</sup> fertility can be achieved via intrauterine insemination<sup>375</sup> or IVF and ICSI.<sup>376</sup>

The change from a female to a male gender identity can be extremely traumatic psychologically, but some have managed the transition quite successfully.<sup>356</sup> In one such case, the patient effectively conducted a “double life,” functioning in all public respects as a female while having numerous clandestine heterosexual relationships. Aware of his male sexual identity since puberty, he nonetheless delayed seeking medical assistance for fear that exposure would bring shame and guilt to his religiously devout elderly “old-world” mother. Although he had planned to keep his secret until his mother died, he finally sought diagnostic help at age 65, because his mother, then age 93, continued to

enjoy good health. The transition from a female to a male gender in an individual with steroid 5 $\alpha$ -reductase deficiency was chronicled in the Pulitzer Prize–winning novel, *Middlesex*, authored by Jeffrey Eugenides, which features the heroine Calliope Stephanides who becomes the hero, Cal.<sup>377</sup>

## 17 $\alpha$ -Hydroxylase Deficiency

The CYP17A1 gene encodes an enzyme having both 17 $\alpha$ -hydroxylase and 17,20-lyase activities, which are required for synthesis of cortisol, androgens, and estrogens. Deficiency of 17 $\alpha$ -hydroxylase is a rare cause of CAH, with little more than 100 cases reported.<sup>378,379</sup> Human 17 $\alpha$ -hydroxylase deficiency syndromes involving a loss of only 17 $\alpha$ -hydroxylase or 17,20-lyase have been observed,<sup>380,381</sup> but in most affected patients, both enzymes are deficient.<sup>382</sup>

The compensatory increase in ACTH stimulation that accompanies decreased cortisol synthesis stimulates increased production of 11-deoxysteroids (via 21-hydroxylase), including corticosterone and the mineralocorticoids 11-deoxycorticosterone and 18-hydroxy-deoxycorticosterone.<sup>383,384</sup> In turn, mineralocorticoid excess leads to volume expansion, which inhibits renin release and the synthesis of aldosterone.<sup>385</sup> Production of androgens (dependent on 17,20-lyase activity) and, subsequently, estrogens is decreased in both the adrenals and the gonads. Serum concentrations of progesterone are increased, but those of 17-OHP, cortisol, DHEA, DHEA-S, androstenedione, testosterone, and estradiol are low.

Like other forms of CAH, 17 $\alpha$ -hydroxylase deficiency is an autosomal recessive disorder. The CYP17A1 gene is located on chromosome 10 (10q24.3) and numerous different mutations have been described,<sup>386</sup> including small insertions that disrupt the normal reading frame of the gene (resulting in early termination),<sup>387</sup> deletions of a single or several codons,<sup>388,389</sup> large deletions with insertion of foreign DNA,<sup>390</sup> and nonsense or missense mutations that yield stop codons or an enzyme with decreased activity.<sup>389,391,392,393,394,395,396,397,398</sup> **Females with 17 $\alpha$ -hydroxylase deficiency typically present with delayed puberty, primary amenorrhea, and hypergonadotropic hypogonadism; most are hypertensive (due to hypernatremia and hypervolemia) and some also have hypokalemia.<sup>399,400</sup> Affected males usually have female external genitalia (male pseudohermaphroditism), a blind vagina, and intra-abdominal testes; most have been raised as girls, with the underlying disorder recognized only later during evaluation for delayed puberty.<sup>401</sup>**

The treatment of 17 $\alpha$ -hydroxylase deficiency involves giving sufficient glucocorticoids to suppress excess production of ACTH and mineralocorticoids while avoiding glucocorticoid excess. Because almost all affected patients are raised as

females, estrogen therapy also should be provided, at the time of diagnosis at puberty or the expected time of puberty. In genetic females having a uterus, progestational treatment also must be provided.

### **3 $\beta$ -Hydroxysteroid Dehydrogenase Deficiency**

Defects in the enzyme 3 $\beta$ -hydroxysteroid dehydrogenase/ D<sup>5</sup>-D<sup>4</sup> isomerase (3 $\beta$ -HSD) and its endocrine and developmental consequences in genetic females are discussed in detail in the earlier section of this chapter devoted to causes of female virilization (46,XX DSD). The enzyme defect is considered here again, briefly, because it can cause incomplete masculinization of males as well as virilization in females.

Type II 3 $\beta$ -HSD catalyzes the oxidation and isomerization of D<sup>5</sup>-3 $\beta$ -hydroxysteroid precursors into D<sup>4</sup>-ketosteroids in the adrenals and gonads. A 3 $\beta$ -HSD deficiency results in the accumulation of excessive amounts of D<sup>5</sup>-3 $\beta$ -hydroxysteroids, including pregnenolone, 17 $\alpha$ -hydroxypregnenolone, DHEA, and DHEA-S, and in low levels of D<sup>4</sup>-ketosteroids such as androstenedione and testosterone and, subsequently, DHT. Consequently, affected males exhibit varying degrees of incomplete masculinization, ranging from hypospadias to nearly normal female external genitalia.<sup>219,402,403</sup>

### **17 $\beta$ -Hydroxysteroid Dehydrogenase Deficiency**

The 17 $\beta$ -hydroxysteroid dehydrogenase (17 $\beta$ -HSD) family of enzymes includes the type 3 isoenzyme, which catalyzes the conversion of androstenedione into the biologically active androgen, testosterone, in the Leydig cells of the testis. Mutations in the HSD17B3 gene, located on chromosome 9 (9q22), can result in 17 $\beta$ -HSD deficiency, an autosomal recessive disorder caused by impaired testicular testosterone production.<sup>404,405</sup> Although rare, 17 $\beta$ -HSD deficiency is the most common hereditary defect in testosterone synthesis.

**Males with homozygous or compound heterozygous mutations have testes and normally developed internal genitalia but have severely undervirilized external genitalia, which typically appear female and include a short, blind vagina, much like patients with incomplete androgen insensitivity.**<sup>405,406</sup> Consequently, most are assigned a female gender at birth and are raised as females. **Alternatively, they can exhibit genital ambiguity, with varying degrees of clitoromegaly and labial fusion, or have male genitalia with micropenis or hypospadias.**<sup>404,407</sup> The testes may be located in the abdomen, in the inguinal canals, or in the labia majora. **Virilization occurs at puberty, probably due to extratesticular conversion of androstenedione to testosterone by unaffected 17 $\beta$ -HSD isoenzymes in peripheral tissues (e.g., liver, skin, adipose).**<sup>405,408,409,410</sup> The phallus enlarges, muscle mass increases, a male body

habitus and hair pattern develop, and the voice may deepen. Gender role reversal has been observed in one- to two-thirds of those affected and raised as girls.<sup>411</sup> Ideally, therefore, the diagnosis is best made before puberty and followed with gonadectomy and estrogen therapy in those with female genitalia. In those born with ambiguous genitalia, early diagnosis may allow male sex assignment because androgen treatment can promote development of a nearly normal adult male phenotype.<sup>412,413</sup>

When suspected, an elevated basal serum androstenedione level and low serum testosterone/androstenedione ratio (<0.8–0.9) after exogenous hCG stimulation suggest the diagnosis of 17 $\beta$ -HSD deficiency, but the method lacks specificity, because normal values have not been firmly established in age-matched controls and because similar results can be observed in individuals with other defects in testosterone biosynthesis or Leydig cell hypoplasia. Genotyping permits definitive diagnosis. A variety of different mutations has been described, most yielding an enzyme having little or no significant activity.<sup>405</sup>

## **P450 Oxidoreductase Deficiency**

The genetics and pathophysiology of P450 oxidoreductase (POR) deficiency are discussed in detail in the earlier section of this chapter devoted to causes of 46,XX DSD (female virilization). The disorder is included again here because, like 3 $\beta$ -HSD deficiency, P450 oxidoreductase deficiency also is among the causes of 46,XY DSD (incomplete masculinization in males).

As described earlier, POR is not a steroidogenic enzyme but a flavoprotein that serves as the electron donor in the activation of all microsomal P450 enzymes, including P450c21 (the adrenal 21-hydroxylase, CYP21A2), P450c17 (CYP17A1, which catalyzes both 17,20-lyase and 17 $\alpha$ -hydroxylase activities), and P450arom (aromatase, CYP19A1, which mediates the conversion of androgens to estrogens).<sup>275</sup> The developmental consequences of POR deficiency in males result primarily from partial deficiencies of 21-hydroxylase and 17,20-lyase, and to a lesser extent, 17 $\alpha$ -hydroxylase activity. Serum concentrations of 17-OHP are elevated and androgen levels are low. Not surprisingly, affected boys often are undervirilized, because decreased 17,20-lyase activity prevents generation of 19-carbon androgens, including testosterone.

## **Steroid Acute Regulatory (StAR) Protein Deficiency**

The rarest and most severe form of CAH is known as congenital lipoid adrenal hyperplasia. The disorder is characterized by a deficiency of all adrenal and gonadal steroid hormones, increased ACTH secretion, and marked adrenal hyperplasia associated with progressive accumulation of cholesterol esters.

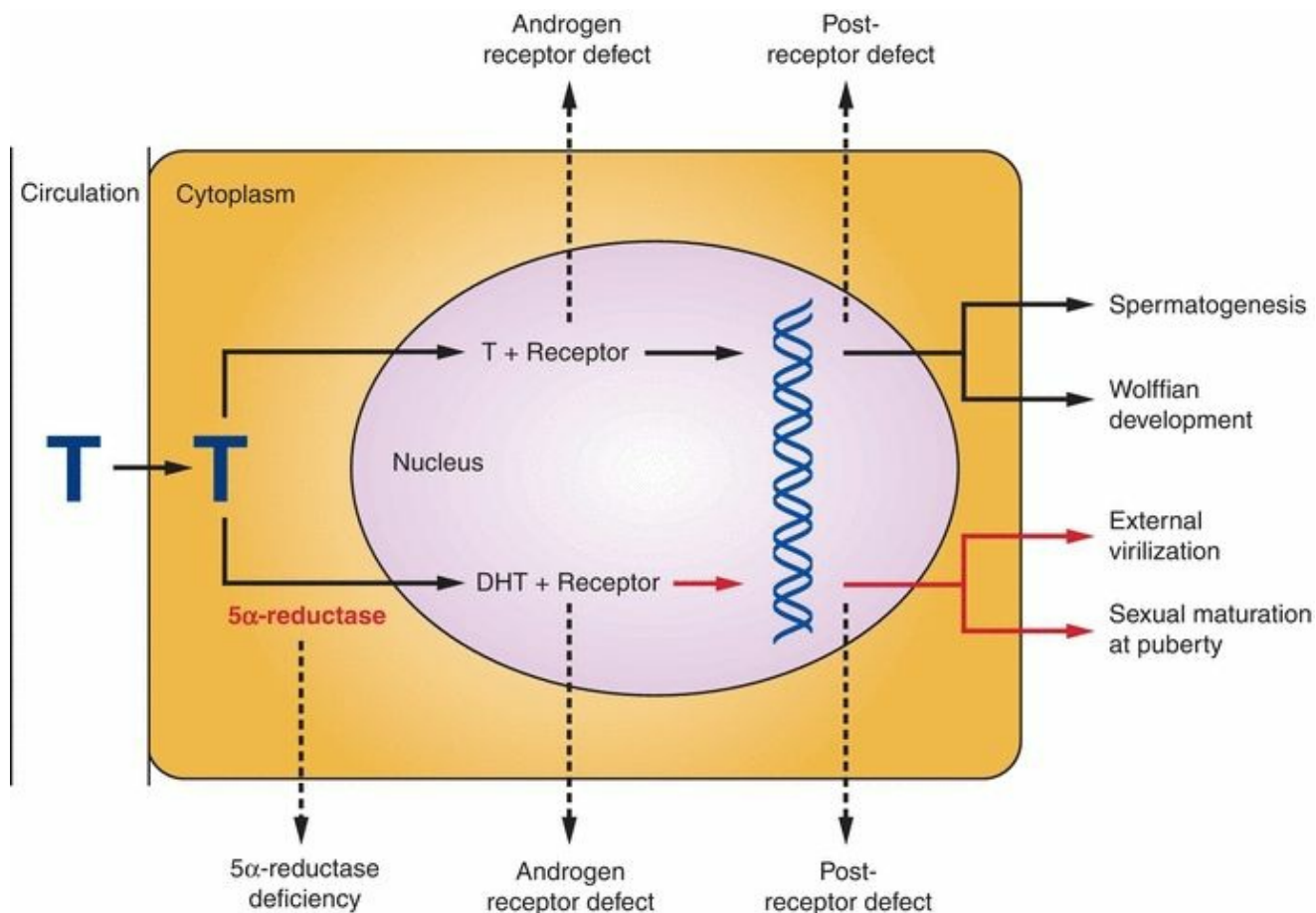
**Congenital lipoid adrenal hyperplasia is an autosomal recessive disorder that**

**results from mutations in the gene encoding the steroidogenic acute regulatory (StAR) protein.**<sup>414,415</sup> StAR mediates the acute response to steroidogenic stimuli by facilitating transport of cholesterol from the outer to the inner mitochondrial membrane, the rate-limiting step in steroidogenesis,<sup>415,416</sup> and is expressed in the adrenal cortex and gonads, but not in the placenta. A wide variety of mutations in the StAR gene (located at 8p11.2) have been described, most resulting in reduced activity of the protein.<sup>414,417,418,419</sup> The disorder also can result from a heterozygous mutation in the CYP11A1 gene encoding the cholesterol side chain cleavage enzyme, which converts cholesterol to pregnenolone.<sup>420</sup> In either case, all steroidogenic pathways are affected, resulting in a global deficiency of steroid hormones that reflects both the intrinsic defect in steroidogenesis and the progressive cellular damage that results from the accumulation of cholesterol.<sup>417</sup> Serum cortisol and aldosterone concentrations are very low, ACTH and plasma renin activity levels are very high, sex steroid concentrations are low, and serum gonadotropin levels are elevated, even in young children.<sup>420,421</sup>

Patients with congenital lipoid adrenal hyperplasia typically present very soon after birth or in early infancy with symptoms of severe adrenal insufficiency (vomiting, diarrhea, volume depletion, hyponatremia, hyperkalemia).<sup>422</sup> Male infants usually have female external genitalia due to the severe androgen deficiency. Females are normally developed at birth and even may undergo spontaneous puberty,<sup>423</sup> possibly because the prepubertal ovary, unlike the adrenals and testes, is relatively dormant and thus may escape cellular damage from cholesterol accumulation. Although two-thirds of reported patients died in infancy,<sup>421</sup> some treated with glucocorticoids and mineralocorticoids have survived to reach puberty.<sup>424</sup>

## Disorders of Androgen Action

Mutations in the gene that encodes the androgen receptor (AR) can produce a variety of phenotypes in males having normal testes and testosterone production; more than 400 different AR mutations have been identified.<sup>425</sup> Collectively, these 46,XY DSD are known as androgen insensitivity syndromes (AISs). The genetics, pathophysiology and endocrinology of androgen receptor disorders are quite similar. The phenotype depends on whether androgen receptors are absent entirely,<sup>426,427</sup> present but functionally abnormal,<sup>428,429,430</sup> or normal but decreased in quantity<sup>428,431</sup> (**Figure 8.11**).



**FIGURE 8.11**

## Complete Androgen Insensitivity Syndrome

Complete androgen insensitivity was first described in detail by Morris, at Yale, who coined the name “testicular feminization.”<sup>432</sup> However, complete AIS now is the preferred term.<sup>433</sup> Complete AIS can result from a wide variety of inactivating mutations in the AR gene, including major gene deletions, premature stop codons, splicing abnormalities, and missense mutations that result in amino acid substitutions in the androgen receptor. The AR gene is located on the X chromosome (Xq12), and complete AIS therefore follows an X-linked recessive pattern of inheritance. One in three phenotypic sisters of an affected individual will have an XY karyotype. Consequently, careful investigation to identify other affected family members is warranted. Approximately 40% of patients with complete AIS have no family history of the disorder,<sup>434</sup> presumably representing de novo mutations.

The pathophysiology, and the phenotype, of complete AIS are logical and predictable. The receptor defect results in insensitivity to androgen. Consequently, androgen-induced wolffian duct development cannot proceed normally; the presence or absence of wolffian duct derivatives (epididymides, vasa deferentia) varies with the

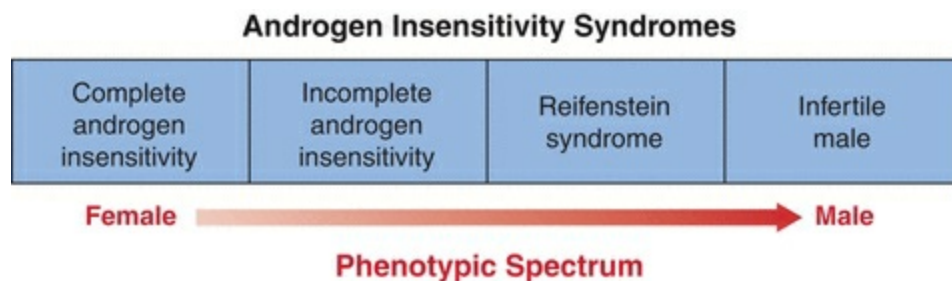
type of mutation. Whereas remnants can be observed (adjacent to the testes) in those having point mutations in the ligand-binding domain of otherwise normally expressed receptors, which may permit a very limited response to high local androgen concentrations in utero, wolffian structures are completely absent in those having mutations that yield premature stop codons or frameshift mutations that prevent androgen receptor expression.<sup>435</sup> The normal testes produce normal amounts of AMH, which effectively suppress müllerian duct development. Therefore, the uterus and fallopian tubes typically are absent, although vestiges also have been observed.<sup>436</sup> The testes may be found in the abdomen but, more commonly, are located in the inguinal canals or in the labia majora, probably because AMH normally mediates their descent; their histology resembles that of undescended testes, with a normal or increased number of Leydig cells and absent spermatogenesis. The external genitalia are clearly female, due to androgen insensitivity, although the labia and clitoris may be slightly underdeveloped. The vagina is either blind and short or altogether absent, reflecting only the developmental contribution of the urogenital sinus. Axillary and pubic hair is scant or absent, again due to androgen insensitivity. Breast development is female and may be enhanced, probably due to the action of estrogen unopposed by the actions of androgens. The overall body habitus also is female, although the average height and weight of women with complete AIS is greater than that of normal women.<sup>437,438</sup> Women with complete AIS also exhibit normal female sexual orientation and maternal instincts.<sup>439,440</sup>

**In women with complete AIS, serum testosterone concentrations are normal or moderately increased, LH levels are increased, and the serum FSH usually is in the normal range.** The increase in LH levels results from resistance to the negative feedback effects of androgens at the hypothalamic-pituitary level; both the frequency and amplitude of pulsatile LH secretion are increased in patients with complete AIS.<sup>441,442</sup> Whereas estrogen production (estrone and estradiol) also is increased by approximately 70% over that in normal men, DHT production is decreased due to the absence of male urogenital tissues, which are the primary site of DHT production.<sup>367</sup>

The diagnosis of complete AIS should be suspected in girls with inguinal hernias or labial masses<sup>443</sup> and in women with primary amenorrhea. In the adolescent or adult, diagnosis usually is not difficult. **Most patients with complete AIS present with primary amenorrhea, normal breast development, absent or scant pubic and axillary hair, a short vagina, and an absent cervix and uterus; a serum testosterone in the normal male range and a 46,XY karyotype establish the diagnosis.** Whereas males with defects in testosterone biosynthesis can have a female phenotype, breast development does not occur. **Patients with complete AIS generally are easily differentiated from those with müllerian agenesis who have normal amounts of pubic and axillary hair, normal female serum testosterone concentrations, and a**

**46,XX karyotype.** The location of the testes usually can be defined by ultrasonography or MRI.<sup>444</sup>

The clinical management of complete AIS includes appropriate hormone therapy, creation of a functional vagina, gonadectomy to prevent tumorigenesis in cryptorchid testes, and psychological support, all discussed in detail in [Chapter 10](#) (Amenorrhea) and summarized here. Estrogen treatment is indicated when gonadectomy is performed after puberty is completed, or at the time of expected puberty if the gonads were removed before puberty. Options for creation of a functional vagina include progressive vaginal dilation and vaginoplasty. The short but distinct vagina observed in most patients with complete AIS facilitates efforts with vaginal dilation,<sup>323,324,369</sup> but surgical treatment also produces good results, when necessary.<sup>370</sup> **In patients with complete AIS, gonadectomy generally is best delayed until after puberty is completed (approximately age 16–18) because pubertal development generally proceeds more smoothly in response to endogenous hormone production and because the overall risk for tumor development is quite low (5–10%), particularly before puberty.**<sup>431,445,446,447</sup> Psychological support should be directed toward reinforcement of their female gender identity and include truthful education for both patient and parents ([Figure 8.12](#)).



**FIGURE 8.12**

### **Incomplete Androgen Insensitivity Syndromes ([Table 8.4](#))**

### **TABLE 8.4 Androgen Insensitivity Syndromes**



	Complete	Incomplete	Reifenstein	Infertile
<b>Inheritance</b>	X-linked recessive	X-linked recessive	X-linked recessive	X-linked recessive
<b>Spermatogenesis</b>	Absent	Absent	Absent	Decreased
<b>Müllerian</b>	Absent	Absent	Absent	Absent
<b>Wolffian</b>	Absent	Underdeveloped	Male	Male
<b>External</b>	Female	Female (clitoromegaly)	Male (hypospadias)	Male
<b>Breasts</b>	Female	Female	Gynecomastia	Male (gynecomastia)

Incomplete AIS describes a variety of disorders that result from defects in androgen action less severe than those associated with complete AIS. **The spectrum of clinical presentations can vary from phenotypic females with mild virilization to undervirilized males who may be fertile or infertile, even within one affected family.**<sup>448,449</sup>

Phenotypic women with mild virilization are at one end of the clinical spectrum of incomplete or partial AIS. They resemble women with complete AIS but have normal body hair, external genitalia exhibiting partial fusion of the labioscrotal folds, with or without clitoromegaly, and they both virilize and feminize at puberty. They have no müllerian structures (due to the actions of AMH), underdeveloped male internal genitalia (epididymides, vasa deferentia, seminal vesicles, ejaculatory ducts), and testes similar to those with complete AIS. Axillary and pubic hair is normal. Breast development, the overall body habitus, and gender identity are distinctly female. The phenotype is approximately one-tenth as common as that of complete AIS.<sup>431</sup>

**Reifenstein syndrome** describes individuals having a predominantly male phenotype who are undervirilized.<sup>450</sup> **The most common clinical presentation is an infertile man with a bifid scrotum and perineoscrotal hypospadias.** However, the appearance of the external genitalia can vary widely, from a microphallus with a normal penile urethra to complete failure of scrotal fusion. The internal genitalia are male but not completely developed; müllerian structures are absent and, usually, so too is the prostate. The testes can be cryptorchid or normally descended and small and exhibit a maturation arrest in spermatogenesis. Men with Reifenstein syndrome have normal axillary and pubic hair but, typically, little or no chest or facial hair. They have a male body habitus but usually develop gynecomastia at the time of puberty. Gender identity corresponds with the sex of rearing, and sexual dysfunction is common in those raised as males.<sup>451,452,453</sup>

**Some men with partial androgen insensitivity are only mildly undermasculinized and infertile.**<sup>454</sup> Their internal and external genitalia are normal and their testes are

normally descended but exhibit either an absent germinal epithelium or spermatogenic arrest. They have normal amounts of body hair and some have gynecomastia. **The prevalence of partial androgen insensitivity in men with azoospermia or severe oligospermia is unknown but may be as high as 10%.**<sup>455,456</sup> Still other men with partial androgen insensitivity are undervirilized but fertile<sup>457,458</sup> (Table 8.4).

Serum hormone levels in phenotypic women with incomplete AIS, in men with Reifenstein syndrome, and in infertile men with partial androgen insensitivity are similar to those in individuals with complete AIS.<sup>450,454,459</sup> In undervirilized fertile men with partial androgen insensitivity, testosterone concentrations are elevated but LH levels are in the normal range.<sup>457</sup>

Whereas major AR gene deletions and premature termination codons have been identified only in patients with complete AIS, point mutations resulting in amino acid substitutions in the androgen receptor can cause the entire spectrum of phenotypes associated with androgen insensitivity. Approximately 80% of amino acid substitutions are located in the hormone-binding domain of the receptor. Most of the remainder is in the DNA-binding domain, permitting normal androgen binding but preventing activation of androgen-responsive genes.<sup>460</sup> How or why different mutations or even the same mutation can result in varying degrees of androgen insensitivity is poorly understood but may relate to differences in the timing of receptor expression, differences in testosterone synthesis or metabolism, differences in transcription factors, or polymorphisms that influence the effect of a given mutation.<sup>460,461,462,463</sup> In some, androgen resistance results not from a mutation in the androgen receptor but from a defective coactivator protein required for normal function of the androgen-androgen receptor complex.<sup>464,465</sup> In others with somatic mosaicism, the androgen receptor is normal in some, but not all, tissues.<sup>466,467</sup>

**Incomplete AIS often presents in newborns, as ambiguous genitalia. In adults, the diagnosis generally is not difficult. Affected individuals present as phenotypic women with mild virilization of the external genitalia (otherwise appearing the same as women with complete AIS) or as phenotypic men with gynecomastia and perineoscrotal hypospadias.** In phenotypic women with incomplete AIS, the family history can be very helpful because others who are affected have a similar appearance, but in undervirilized men, the phenotype of affected family members can vary significantly. At all ages, the differential diagnosis includes steroid 5 $\alpha$ -reductase deficiency, defects in testosterone biosynthesis, and mixed gonadal dysgenesis, which is discussed below. The ratio of testosterone to DHT in serum helps to differentiate incomplete AIS from steroid 5 $\alpha$ -reductase deficiency; the ratio is normal in most with incomplete AIS but increased in patients with steroid 5 $\alpha$ -reductase deficiency. In most cases, androgen receptor defects can be differentiated from defects of testosterone

biosynthesis by the serum testosterone concentration, which typically is normal or high in the former and decreased in the latter. Individuals with mixed gonadal dysgenesis (characterized by a unilateral testis, a contralateral streak gonad, and a 46,XY or 45X/46,XY karyotype) often have a single descended gonad or exhibit some of the phenotypic features of Turner syndrome. Androgen insensitivity also should be suspected in undervirilized men with azoospermia or severe oligospermia. Testosterone or LH concentrations may be elevated but are normal in most<sup>455</sup>; some have high serum FSH levels and resemble men with microdeletions in the AZF (azoospermia factor) region of the Y chromosome.<sup>468</sup> Although only a few families with the undervirilized fertile male syndrome have been reported, the disorder might be suspected in undervirilized men with a normally formed male urethra and gynecomastia, particularly in those having other family members who are similarly affected.

Androgen receptor binding can be evaluated in vitro, using cultured fibroblasts derived from genital skin. However, the method is labor intensive and costly and cannot exclude abnormalities of androgen receptor function unrelated to binding. Techniques involving the insertion of an androgen-responsive reporter gene in fibroblasts that can demonstrate impaired androgen receptor function have been described, but their usefulness for diagnosis of mild androgen insensitivities is unclear.<sup>469</sup> **The most reliable method for diagnosis of androgen insensitivity is to sequence the AR gene using DNA derived from blood or tissue, with reference to a database that lists all of the mutations that have been identified in patients with androgen insensitivity.** Once characterized, the defect can be identified in fetuses at risk using DNA obtained via CVS or amniocentesis or in embryos using preimplantation genetic testing for monogenic disorders (PGT-M, previously called PGD).<sup>470,471,472</sup>

The clinical management of incomplete AIS syndromes is directed toward appropriate gender assignment in infants with ambiguous genitalia, hormone therapy, psychological support, gonadectomy to prevent tumorigenesis in cryptorchid testes, reconstructive surgery where it is needed, and the treatment of gynecomastia in men.

**In determining gender assignment, the size of the phallus and the feasibility of constructing a penile urethra are the most important considerations.** For phenotypic females and those who are raised as females, estrogen treatment is indicated when gonadectomy is performed after puberty or at the expected time of puberty if gonadectomy was performed earlier. **Whereas adult women can receive normal doses of estrogen therapy immediately, the age and the dose of treatment in children must consider the growth percentile, growth velocity, bone age, target height, and predicted adult height.** In boys with Reifenstein syndrome, treatment with high doses of testosterone or DHT can achieve greater phallic growth<sup>473,474,475</sup>; in adult men, high-dose testosterone treatment can,<sup>371,476</sup> but does not always,<sup>442</sup> improve masculinization.

As in women with complete AIS, psychological support should be aimed at truthful education after consultation with the family and the development of a support network; early disclosure may help to limit emotional trauma.<sup>477</sup> Gonadectomy is performed to eliminate the risk of tumors developing in cryptorchid testes (1–2% of undescended testes, more often in abdominal than in inguinal testes), some of which are malignant.<sup>478</sup> **Whereas gonadectomy generally is best postponed until after puberty is completed in women with complete AIS, earlier surgery is indicated to prevent the virilization at puberty in those with incomplete AIS.** In boys with Reifenstein syndrome, early surgery to correct cryptorchidism both decreases the risk of tumor and helps to maximize testicular function. The gynecomastia observed in men with Reifenstein syndrome and in undervirilized fertile males, which results from both increased estrogen production and androgen resistance, can be treated by mastectomy when it is disfiguring or otherwise disturbing to the individual. The incidence of breast cancer may be increased in men with Reifenstein syndrome.<sup>479</sup>

## LH Receptor Defects

**Leydig cell hypoplasia, describing the absence of mature Leydig cells in the testes, is a rare autosomal recessive 46,XY disorder of sexual development caused by inactivating mutations in the LH/hCG receptor.**<sup>480,481</sup> Testicular Leydig cell testosterone production is stimulated by hCG during fetal life and by LH after birth. In the fetus, the number and differentiation of Leydig cells and levels of androgen production parallel the changes in serum hCG concentrations during pregnancy. Consequently, a decrease in the number or function of Leydig cells results in decreased fetal testosterone production and in the failure of normal male sexual differentiation. Large deletions or nonsense mutations in the LH/hCG receptor gene (LHCGR) yield defective receptors that prevent normal hormone binding; more subtle mutations allow binding but prevent normal signal transduction or cause misfolding of the receptor that interferes with its normal transport to the cell surface.<sup>481,482,483</sup>

In affected individuals, müllerian duct derivatives are absent (reflecting the normal action of AMH), wolffian duct development is impaired (reflecting the decreased level of testosterone production), and the testes fail to descend, because normal descent requires the actions of testosterone and insulin-like factor 3, both deriving from Leydig cells.<sup>484,485</sup> **The phenotype of patients with Leydig cell hypoplasia otherwise generally correlates with the level of residual LH/hCG receptor activity, ranging from completely female external genital development to nearly normal male genitalia.** Those having no significant testosterone production appear female at birth and present at puberty with primary amenorrhea and sexual infantilism, lacking both pubic hair development (due to the lack of testosterone) and breast development (due to

the absence of aromatizable substrate); the serum LH concentration is elevated and testosterone levels are abnormally low. Others in whom LH receptor function is only partially impaired and testosterone production is decreased but still significant can present with ambiguous genitalia, hypospadias, or micropenis.<sup>481,483</sup>

## **Disorders of Antimüllerian Hormone and Its Receptor**

The **hernia uterine inguinale syndrome** is a rare autosomal recessive disorder that results from a failure of müllerian duct regression, due to mutations in the genes encoding AMH or its receptor.<sup>486,487</sup> Affected patients appear as normal males having an inguinal hernia containing relatively well-differentiated müllerian duct structures, usually including a uterus and fallopian tubes. They have normal male internal and external genitalia and, usually, cryptorchid testes. In affected families, genetic studies have identified mutations in the AMH gene in 45% and in the AMHR2 receptor gene in another 39%; in the remaining 15%, no mutation was detected, implicating genes coding for other factors in the AMH transduction cascade.<sup>488</sup>

# Sex Chromosome Disorders of Sexual Development

Sex chromosome DSD describes a group of disorders associated with an abnormal karyotype, including 45,X (Turner syndrome and variants), 47,XXY (Klinefelter syndrome and variants), 45,X/46,XY mosaicism (mixed gonadal dysgenesis), and 46,XX/46,XY mosaicism (chimerism). Ovotesticular DSD (true hermaphroditism), discussed in the earlier section of this chapter devoted to 46,XX DSD, also can be associated with a mosaic 45,X/46,XY or 46,XX/46,XY karyotype.

## 45,X (Turner Syndrome and Variants)

Turner syndrome was first described in 1938<sup>489</sup> and now is recognized as important cause of short stature in girls and primary amenorrhea in young women. The disorder also is discussed in [Chapter 10](#), as a cause of amenorrhea. Turner syndrome results from loss of all or part of an X chromosome and is very common; approximately 15% of all spontaneous abortions have a 45,X karyotype.<sup>490,491</sup> The incidence of Turner syndrome among newborn girls ranges around 1 in 2,000–5,000 live-born phenotypic females.<sup>492,493,494</sup>

Although Turner syndrome classically is associated with a 45,X karyotype, more than half of patients are mosaics (e.g., 45,X/46,XX). The prevalence of mosaicism varies directly with the method used for detection, ranging from 34% with conventional cytogenetics, to 60% with fluorescence in situ hybridization, to nearly 75% when a reverse transcriptase PCR assay is used.<sup>495</sup> Some patients with Turner syndrome lack only part of one X chromosome or exhibit one of a variety of structural abnormalities of the X, including ring chromosomes, isochromosomes, and terminal deletions.

## Clinical Features

**The sine qua non of Turner syndrome is short stature.** It is the only abnormality present in virtually all patients and can be attributed to deletion of the short stature homeobox-containing gene (SHOX), which is located in the pseudoautosomal region at the distal end of the short arm of the X chromosome (Xp22.33).<sup>496,497</sup> **The classical phenotype of Turner syndrome also includes the absence of sexual development, a webbed neck, low set ears and posterior hairline, widely spaced nipples (“shield chest”), short fourth metacarpals, and an increased carrying angle at the elbow (“cubitus valgus”).** The phenotype of patients with Turner syndrome relates, in part, to the parental origin of their X chromosome; most with a 45,X karyotype retain the maternal X.<sup>498</sup>

Most women with Turner syndrome have no pubertal development and primary amenorrhea. However, some develop normally and later present with secondary amenorrhea. Approximately 15% of patients with Turner syndrome begin but do not complete pubertal development and approximately 5% complete puberty and begin menstruation.<sup>499</sup> The streak gonads in women with Turner syndrome characteristically are composed of connective tissue with no follicles or only a few atretic follicles. About one-third have ovaries that can be imaged with pelvic ultrasonography, and those who do more commonly exhibit spontaneous breast development at puberty.<sup>500</sup> Although a few women with Turner syndrome conceive naturally, pregnancies are rare and associated with a relatively high risk for sex chromosome aneuploidy and spontaneous abortion.

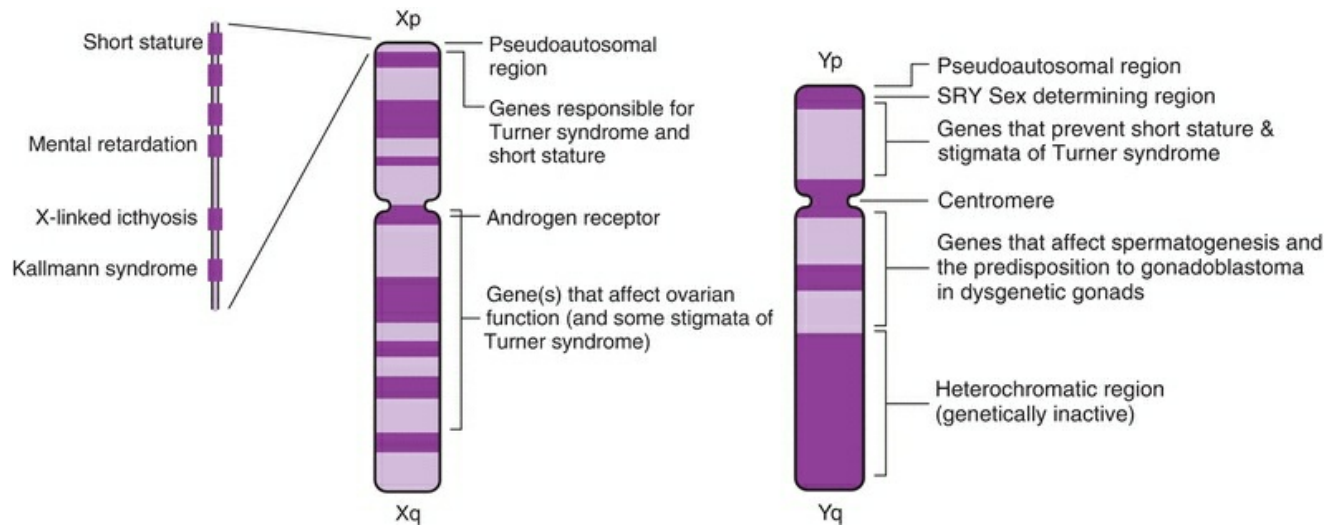
Approximately 30–50% of patients with Turner syndrome have renal anomalies; horseshoe kidney is the most common and predisposes to hydronephrosis due to obstruction.<sup>501,502</sup> Cardiac malformations also are common. Approximately 20–30% of patients have aortic valve disease (bicuspid aortic valve, aortic root dilation) and 3–10% have coarctation<sup>503,504,505,506</sup>; The prevalence of cardiac anomalies may be higher in those with a 45,X karyotype than in mosaics.<sup>504</sup> Other cardiovascular anomalies include elongation of the transverse aortic arch (49%), persistent left superior vena cava (13%), anomalous pulmonary venous return (13%), and an aberrant right subclavian artery (8%); their prevalence is higher in patients with abnormal neck and chest development.<sup>507</sup> A prolonged QT interval can be observed, even in young children with Turner syndrome.<sup>508,509</sup> Idiopathic hypertension also is common, even in the absence of any apparent renal or cardiac malformations.<sup>510,511</sup>

Patients with Turner syndrome are predisposed to developing osteoporosis, primarily due to ovarian failure but possibly also relating to haploinsufficiency for genes affecting bone located on the X chromosome.<sup>512,513</sup> Many also have ocular abnormalities, including amblyopia, strabismus, ptosis, hypertelorism, epicanthus, farsightedness, and red-green color blindness.<sup>514,515,516</sup> The prevalence of endocrine diseases such as hypothyroidism and diabetes is increased and, for hypothyroidism, correlates with the karyotype (X isochromosome, 38%; 45,X, 14%; other, 6%).<sup>517</sup> Celiac disease, hearing loss, and liver function abnormalities also are more common in patients with Turner syndrome.<sup>518,519,520,521</sup>

Patients with Turner syndrome typically have normal intelligence.<sup>522</sup> The rare patient having a small X-ring chromosome may have severe mental retardation, because the ring chromosome does not undergo X-inactivation.<sup>523,524</sup> Nonetheless, formal evaluation of intellectual, learning, and motor skills generally is recommended before enrollment in school.<sup>525</sup> Attention deficit/hyperactivity disorder (ADHD)<sup>526</sup> and

problems with visual-spatial organization<sup>527</sup> are more common in girls with Turner syndrome.

Overall mortality is increased approximately threefold, relating primarily to circulatory disease, diabetes, and liver and renal disease.<sup>528</sup> Although overall cancer risk in women with Turner syndrome is similar to that in the general population, the incidence of CNS tumors, bladder cancer, and endometrial cancer may be increased, and the risk of breast cancer is decreased<sup>529</sup> (Figure 8.13).



**FIGURE 8.13**

## Diagnosis

The diagnosis of Turner syndrome sometimes is incidental, discovered when prenatal CVS or amniocentesis is performed for advanced maternal age or prenatal testing raises suspicion for chromosomal anomalies.<sup>530</sup> Diagnosis can be made at birth but often is delayed until childhood or adolescence. Neonates frequently exhibit lymphedema of the hands and feet, a webbed neck, nail dysplasia, a high palate, or short fourth metacarpals; short stature and delayed puberty are the later diagnostic keys.<sup>531</sup> **Therefore, karyotyping is recommended for all girls with unexplained short stature, delayed puberty, a webbed neck, lymphedema, or aortic coarctation and should be considered for those with two or more phenotypic features suggesting the diagnosis.**

Karyotype should include an examination of at least 30 cells, to detect significant mosaicism (e.g., 45,X/46,XX; 45,X/46,XY). For those with a suspicious phenotype but having a normal lymphocyte karyotype, a second tissue (e.g., skin fibroblasts) should be



examined to exclude tissue-specific mosaicism.<sup>532</sup> **Patients with Turner syndrome having a chromosomal fragment of uncertain origin and those exhibiting any evidence of virilization also should be evaluated specifically using FISH and Y chromosome-specific probes, because those having all or part of a Y (approximately 5%) are at increased risk for developing gonadoblastoma.**<sup>533,534,535,536,537</sup>

## Clinical Management

The spectrum of medical problems in patients with Turner syndrome and their health implications require specific evaluation and periodic monitoring, as described in detail in [Chapter 10](#).<sup>534</sup> In brief summary, evaluation should include periodic echocardiography (or MRI if required), renal ultrasonography, thyroid function studies, a complete blood count, fasting glucose, lipid profile, and renal and liver function tests, antiendomysial antibodies (to detect celiac disease), and audiometry. Those with coarctation of the aorta should undergo surgery for its correction, and those with other anomalies must be monitored carefully. Hypertension, hypothyroidism, and hearing and visual problems also require specific treatment.

Growth hormone therapy should begin as soon as height falls below the 5th percentile for age, usually between 2 and 5 years of age.<sup>538</sup> Early diagnosis and treatment with growth hormone can increase lean body mass<sup>539</sup> and help patients to achieve a normal adult height.<sup>540,541,542</sup> Combined treatment with growth hormone and low doses of oxandrolone (an anabolic steroid) can help to maximize growth for older girls between 9 and 12 years of age when diagnosis is delayed.<sup>543,544</sup> Estrogen therapy decreases height velocity and gain in height and therefore generally is not recommended before age 13 or 14 years.<sup>543,545,546</sup> **Estrogen treatment should begin at a low dose (0.25–0.5 mg micronized estradiol or its equivalent) and increase gradually at 3–6-month intervals until reaching the final dose (2.0 mg micronized estradiol or its equivalent); the goal is to complete sexual maturation over a period of 2–3 years. Transdermal options may offer a superior metabolic profile benefit.** Once treatment with estrogen begins, linear growth will continue for no longer than another 18–36 months. Treatment with a cyclic progestin (e.g., medroxyprogesterone acetate, 5 mg daily for 12–14 days of each month) should begin after the first episode of menstrual bleeding or after 12–24 months of treatment.<sup>534</sup> Treatment with oral contraceptives offers a convenient alternative for longer-term management. Recent reconsideration regarding oral estrogens due to the first-pass effect from the liver has made transdermal estrogens a potentially more preferred option. A meta-analysis showed improved whole-body bone mineral density, fasting glucose, and total cholesterol with transdermal estrogen. The lowest commercially available patches deliver 14–25

µg/day. These can be cut into smaller pieces to deliver 3–7 µg daily, which is recommended at the start of puberty or 11–12 years of age. The dose is then escalated in 6-month intervals up to a 100-µg daily dose following 2–3 years of therapy.<sup>547</sup>

**Oocyte donation offers the possibility of pregnancy to patients with Turner syndrome, but the cardiovascular demands of pregnancy pose unique and potentially serious risks that must be carefully considered. The risk of death during pregnancy is increased as much as 100-fold, primarily due to complications of aortic dissection or rupture.** Risk is greatest for those with preexisting abnormalities such as a bicuspid aortic valve or a dilated aortic root, but even those without such findings remain at risk. Consequently, Turner syndrome generally should be regarded as a relative contraindication to pregnancy. Those expressing serious interest in oocyte donation must receive thorough evaluation and counseling, and those having any significant cardiac abnormality should be strongly discouraged.<sup>548</sup>

## **47,XXY (Klinefelter Syndrome and Variants)**

Klinefelter syndrome is the most common congenital cause of hypogonadism in males, affecting approximately 1 in 1,000 male births.<sup>549,550</sup> The most common karyotype associated with the disorder is 47,XXY, but additional X chromosomes (e.g., 48,XXXY) and mosaics (e.g., 46,XY/47,XXY) also have been described.<sup>551</sup> Klinefelter syndrome results from nondisjunction of the sex chromosomes of either parent during meiosis; mosaics likely result from mitotic nondisjunction.

The phenotype of men with Klinefelter syndrome varies with the number of extra X chromosomes.<sup>551</sup> The gonads are almost always small and firm and sperm production usually is severely decreased. Serum testosterone concentrations generally are low, causing decreased virilization, and gonadotropin levels are elevated.<sup>552</sup> The body habitus exhibits long arms and legs, due both to a long bone abnormality and the influence of testosterone deficiency, and a short trunk. Affected patients also commonly exhibit a variety of psychosocial problems unrelated to hypogonadism.<sup>553,554,555</sup> The prevalence of pulmonary disease, breast<sup>556</sup> and mediastinal cancers,<sup>557</sup> varicose veins, and diabetes is increased in patients with Klinefelter syndrome.<sup>558</sup> Their mortality from breast cancer is higher than in the general population, and that from prostate cancer is lower.<sup>559</sup>

**Diagnosis of Klinefelter syndrome is made by karyotype.** Hypogonadism can be treated effectively with testosterone. Fertility is possible via ICSI, even when there are no sperms in the ejaculate. In a substantial number of azoospermic men with Klinefelter syndrome, sperms can be obtained via testicular sperm extraction (TESE). However, the prevalence of sex chromosome hyperploidy and autosomal aneuploidies is increased

in sperms obtained from men with Klinefelter syndrome, compared to normal men, and those chromosomal errors might in some cases be transmitted to their offspring unless preimplantation or prenatal testing is performed.<sup>560</sup>

## **45,X/46,XY (Mixed Gonadal Dysgenesis)**

Mixed gonadal dysgenesis is a term used to describe asymmetrical gonadal dysgenesis, where one gonad can be identified as a testis and the other is a streak or absent altogether. The most common karyotype associated with the condition is 45,X/46,XY. The dysgenetic testis typically contains immature seminiferous tubules lined by immature Sertoli cells and primitive germ cells. Rarely, the gonad contains primitive sex cord-like structures, with or without germ cells, within an ovary-like stroma.<sup>561</sup>

The phenotype in mixed gonadal dysgenesis can vary widely, probably reflecting the relative proportions of 45,X and 46,XY cells in the gonadal ridge. **Typically, the genitalia are ambiguous, but also can be female or male.** Müllerian and wolffian duct development correspond with the character of the ipsilateral gonad.<sup>562,563</sup> In prepubertal children, basal serum testosterone and gonadotropin concentrations are normal and the testosterone response to exogenous hCG stimulation is highly variable. After puberty, patients exhibit varying degrees of virilization, depending on the level of testosterone production, and serum gonadotropin concentrations are elevated.<sup>563</sup> As might be expected, the incidence of gonadal tumors is relatively high (25%).

## **45,XX/46,XY (Chimerism)**

Chimerism is the term used to describe one body derived from the fusion of cells from both twins of a dizygotic pair. **All chimeras are, by definition, mosaics but are derived from two distinct zygotes rather than from a single zygote.**<sup>564</sup> Chimeras are not visibly different unless a developmental anomaly in one of the cell lines or sex discordance between the cell lines causes a visibly abnormal phenotype. Most known chimeras are discovered in one of two ways. One is random chance, when people with normal phenotypes are genotyped (e.g., as prospective transplant donors or recipients) and found to carry three or four alleles at multiple loci, instead of one or two.<sup>565,566,567,568</sup> Most of the other known chimeras are recognized because of a sex difference between their cell lines, resulting in anomalies of sexual anatomy, maturation, or function that spur the search for an explanation, leading to discovery of mixed cell lines.<sup>569,570</sup> Consequently, a predominance of abnormal sexual development can be expected in chimeras, due to ascertainment bias. The disturbance in sexual development presumably results from conflicting directions generated by sexually distinct gonadal cells during embryogenesis.

# DIAGNOSIS AND MANAGEMENT OF AMBIGUOUS GENITALIA

---

A newborn infant with ambiguous external genitalia presents a major diagnostic challenge and a social and medical emergency. The physicians involved must make an important decision regarding the sex of rearing. The evaluation must be organized and efficient to ensure that the appropriate gender is assigned, that potential life-threatening conditions are recognized, and that the necessary medical, surgical, and psychological interventions begin promptly. A multidisciplinary approach is essential, drawing on the expertise of specialists in neonatology, endocrinology, urology, genetics, psychology, and, if available, medical ethics.<sup>571</sup> Diagnostic procedures may delay the decision, but a period of delay is far better than a later reversal of sex assignment. Naming the child should be delayed until a gender is firmly assigned. Open communication with the parents and family is key, emphasizing initially that the team will work with them to make the best possible decisions and that the child can become a well-adjusted, functional member of society. Ideally, one member of the team should be designated to conduct discussions with the family.<sup>572</sup> Parental education, guidance, support, and ongoing communication with the family's primary care physician are essential.<sup>573,574</sup>

# Diagnostic Evaluation

The initial evaluation of an infant with ambiguous genitalia should include a thorough history, complete physical examination, abdominal/pelvic ultrasonography, a karyotype and FISH for SRY, and endocrine studies of adrenal and gonadal steroid secretion.

## History and Physical Examination

The history should focus on identifying any prenatal exposure to androgens or medications that might act as endocrine disruptors, maternal virilization during pregnancy, and any previously affected relatives, unexplained infant death, or consanguinity.

A careful physical examination cannot establish a diagnosis but can provide useful clues. The presence or absence of dysmorphic features or other anomalies should be noted because the finding usually excludes most forms of CAH and suggests a broader pattern of malformations characteristic of a trisomy (trisomy 21, 18, or 13) or a specific syndrome. Hyperpigmentation suggests high levels of ACTH as in CAH. A systematic examination of the genitalia should answer each of the following questions:

- **Are gonads palpable?** Palpation of the genital and inguinal regions is perhaps the most important part of the physical examination. Gonads in the inguinal regions or in scrotal folds are almost certainly testes.<sup>575</sup> Asymmetry of the gonads or genitalia suggests gonadal dysgenesis or the presence of both testis and ovary (ovotesticular DSD). **Gonads that are not palpable may be in the abdomen and can be ovaries or testes, but virilizing CAH must be excluded specifically.**
- **What is the length and diameter of the phallus?** Careful examination of the phallus may help differentiate between a penis and a clitoris. Whereas the penis has a midline ventral frenulum, the clitoris has two folds extending from its lateral aspects to the labia minora. The phallus should be measured from the pubic ramus (compressing any suprapubic fat) to the tip of the glans (excluding any excess foreskin) after stretching to the point of resistance; diameter should be measured at the midpoint. Measurements should be compared to established norms, which are adjusted for gestational age. In a term infant, normal penile length is 2.5 cm or greater and normal diameter is 0.9 cm or greater.<sup>576</sup> In normal neonates, clitoral length ranges between 2 and 6 mm and measurements greater than 9 mm are unusual.<sup>577,578</sup> Micropenis that is not accompanied by hypospadias can be caused by decreased testosterone production in utero or by growth hormone or gonadotropin deficiency. Clitoromegaly resulting from androgen exposure can be caused by maternal androgen exposure, CAH, or ovotesticular DSD.

- **What is the position of the urethral meatus?** The urethral meatus may be found anywhere along the ventral surface of the phallus or on the perineum. Hypospadias is almost always accompanied by chordee, which is a ventral curvature of the phallus resulting from a shortened urethra. A single opening at the base of the phallus can represent either an incompletely fused penile urethra (hypospadias) or a virilized urogenital sinus. In either case, the findings must be confirmed radiologically or by cystoscopy/vaginocopy.
- **Are the labioscrotal folds fused?** The findings can range widely from the unfused labia majora of a normal female, to varying degrees of posterior fusion, to a bifid scrotum, to a fully fused normal-appearing male scrotum. The anogenital ratio is defined by the distance from the anus to the posterior fourchette of the vagina, divided by the distance from the anus to the base of the clitoris.<sup>579</sup> A ratio greater than 0.5 suggests virilization and some degree of labioscrotal fusion. Once the karyotype is known, the extent of virilization can be further defined by comparison to established gender-specific standards<sup>139,580</sup> to more objectively document the genital phenotype.

## Imaging

Imaging with abdominal and pelvic ultrasonography can help to determine the location of the gonads and the presence or absence of a uterus. However, an infantile uterus can be difficult to image, even with MRI. Imaging is informative when it reveals a uterus but inconclusive when it does not. Although a retrograde urethrogram can be used, cystoscopy/vaginocopy generally is the best method for defining the urethral and vaginal anatomy.<sup>581</sup> Rarely, laparoscopy may be needed to confidently define the reproductive anatomy and to biopsy the gonads.

## Initial Laboratory Evaluation

The initial laboratory evaluation should include the following:

- Karyotype, to determine the chromosomal sex
- FISH, to determine the presence or absence of SRY
- Measures of adrenal and gonadal steroid secretion, including:
  - 17-OHP—rapidly excludes CAH due to 21-hydroxylase deficiency, a common cause of ambiguous genitalia that can be life-threatening.
  - Electrolytes—should be measured immediately and monitored at least daily until salt wasting can be excluded.
  - ACTH, cortisol, DHEA, 17 $\alpha$ -hydroxypregnenolone, and 11-desoxycortisol—identify less common causes of CAH caused by enzyme deficiencies other

than 21-hydroxylase deficiency.

# Differential Diagnosis

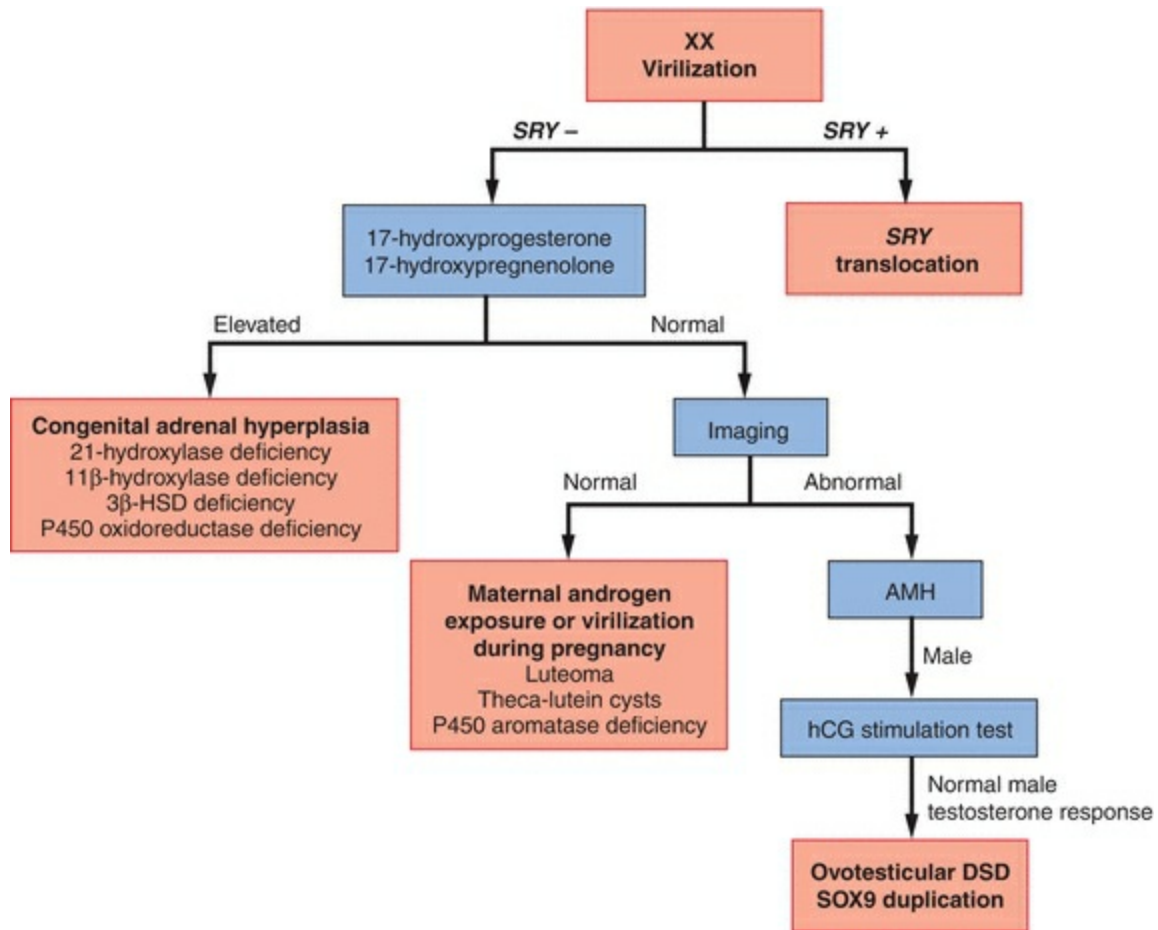
Based on the karyotype, the infant can be placed in one of three diagnostic categories: (1) XX virilization, (2) XY undervirilization, or (3) mixed sex chromosome pattern.<sup>115</sup>

## XX Virilization

The differential diagnosis of XX virilization includes disorders of gonadal (ovarian) development and androgen excess of fetal, fetoplacental, or maternal origin. FISH detection of SRY indicates an SRY translocation. In the absence of SRY, CAH is the most common diagnosis in XX virilized infants. An elevated serum 17-OHP or 17 $\alpha$ -hydroxypregnenolone concentration clearly suggests CAH. The most common cause, 21-hydroxylase deficiency, can be differentiated from other less common causes of CAH (11 $\beta$ -hydroxylase, 3 $\beta$ -HSD, and P450 oxidoreductase deficiencies) by the serum levels of ACTH, cortisol, DHEA, and 11-desoxycortisol, because each has a characteristic serum steroid hormone pattern (described in earlier sections of this chapter).

When CAH has been excluded, imaging revealing a uterus or a history of maternal androgen exposure or virilization during pregnancy points clearly toward maternal gestational hyperandrogenism (pregnancy luteoma, theca-lutein cysts) or P450 aromatase deficiency. Some of the remaining uncommon causes of XX virilization due to testicular DSD can be differentiated by measuring AMH (or inhibin B) and performing an hCG stimulation test (described below); male levels of AMH and a normal testosterone response to hCG indicate the presence of functional testicular tissue, suggesting the diagnosis of ovotesticular DSD or a SOX9 duplication<sup>127,582</sup> (**Figure 8.14**).





**FIGURE 8.14**

## XY Undervirilization

The differential diagnosis of XY undervirilization includes disorders of gonadal (testicular) development, disorders of androgen synthesis or action, LH receptor defects, and disorders of AMH and its receptor. The diagnostic evaluation for SRY-positive infants is challenging due to the large number of possible causes. In addition to the initial laboratory evaluation described above, XY undervirilized infants require further evaluation by measuring the serum LH, FSH, AMH, testosterone, androstenedione, and DHT concentrations. Gonadotropin and sex steroid levels should be measured when they normally are detectable, either in the first 24 hours after birth or between 2 and 6 months of age.<sup>583,584</sup> Provocative tests (ACTH stimulation test, hCG stimulation test) and other specialized tests also may be required to establish a diagnosis.

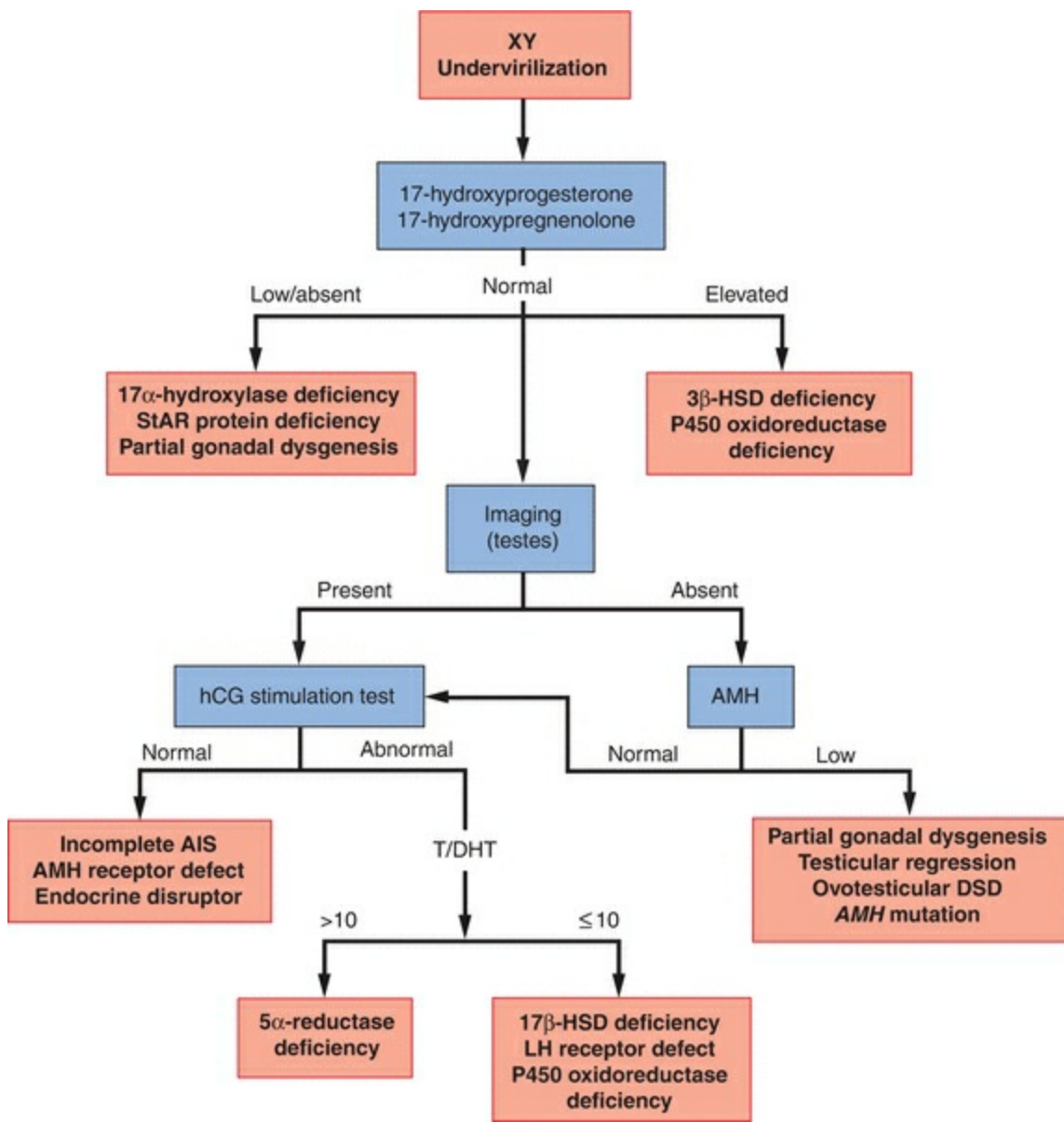
The serum concentrations of 17-OHP and 17 $\alpha$ -hydroxypregnenolone help to narrow the spectrum of diagnostic possibilities. Low or absent levels indicate a 17 $\alpha$ -hydroxylase or StAR protein deficiency or partial gonadal dysgenesis (SF1 mutation,

DAX1 duplication), and elevated levels point to a 3 $\beta$ -HSD or P450 oxidoreductase deficiency; an ACTH stimulation test can better demonstrate the different adrenal enzyme deficiencies<sup>585</sup> and also excludes adrenal insufficiency. The test involves measurements of serum ACTH, cortisol, progesterone, pregnenolone, 17-OHP, 17 $\alpha$ -hydroxypregnenolone, DHEA, and androstenedione before and 60 minutes after administering cosyntropin (synthetic ACTH 1–24; 1 mg/m<sup>2</sup> or 0.25 mg)<sup>182</sup>; hormone values must be compared to age-adjusted normal ranges. The absence of any significant steroidogenic response suggests partial gonadal dysgenesis due to a StAR deficiency, an SF1 mutation, or a DAX1 duplication. Normal 17-OHP and 17 $\alpha$ -hydroxypregnenolone concentrations require additional evaluation.

AMH (or inhibin B) is a marker of Sertoli cell mass and identifies patients having functional testicular tissue, even when the testes cannot be imaged.<sup>586</sup> A low serum AMH level suggests a form of partial gonadal dysgenesis, testicular regression syndrome, ovotesticular DSD, or an AMH mutation. Those with AMH mutations typically have normal male external genitalia, variable testicular descent, and persistent müllerian ducts. When the serum AMH level is normal or imaging reveals testes, disorders of androgen synthesis (steroid 5 $\alpha$ -reductase, 17 $\beta$ -HSD, and P450 oxidoreductase deficiencies), LH receptor defects, incomplete androgen insensitivity, and AMH receptor defects must be considered. In patients with steroid 5 $\alpha$ -reductase deficiency, the testosterone/DHT ratio typically is greater than 10. In those with 17 $\beta$ -HSD deficiency, the serum testosterone concentration often is in the lower normal range, but the serum androstenedione level is elevated severalfold and the testosterone/androstenedione ratio usually is less than 0.8.<sup>587</sup> In patients with LH receptor defects, LH levels are high, testosterone concentrations are low, and androstenedione levels are not elevated. An hCG stimulation test helps to better define and distinguish suspected enzyme deficiencies from incomplete androgen insensitivity and LH receptor defects. The test involves measurements of serum hCG, LH, FSH, testosterone, androstenedione, and DHT on days 1 (basal), 3, and 6, with exogenous hCG (1,500 IU/m<sup>2</sup>) administered on days 1 and 3. A normal response is a twofold increase in the testosterone level on day 3 and a fourfold rise on day 6, a testosterone/DHT ratio less than 10,<sup>366</sup> and a testosterone/androstenedione ratio greater than 0.8.<sup>587</sup> However, because endocrine evaluation may not distinguish clearly between patients with 17 $\beta$ -HSD deficiency and those with LH receptor defects, genotyping may be required to establish the correct diagnosis.

In patients exhibiting normal basal and stimulated androgen levels, the remaining possibilities include incomplete androgen insensitivity, an AMH receptor defect, and prenatal exposure to an endocrine disruptor. Sequencing of the AR gene will identify some, but not all, patients with incomplete AIS; a demonstrable mutation will be found

in fewer than half of those in which the diagnosis is suspected,<sup>464</sup> and other possibilities (e.g., SF1 mutation) must then be considered. Those having an AMH receptor mutation typically have normal male external genitalia and cryptorchid testes. Occasionally, ambiguous genitalia may result from prenatal exposure to phenytoin, phenobarbital, or an environmental exposure<sup>588</sup> (Figure 8.15).



**FIGURE 8.15**

### Mixed Sex Chromosome Pattern

The differential diagnosis of a mixed sex chromosome pattern includes only a few disorders associated with genital ambiguity, such as mixed gonadal dysgenesis,

ovotesticular DSD, and chimerism. Patients with mixed gonadal dysgenesis typically exhibit external genital asymmetry, and those with ovotesticular DSD generally can be expected to have a low serum AMH level.

# Clinical Management of Children with Ambiguous Genitalia

The management of children born with ambiguous genitalia focuses initially on stabilization, averting the possibility of adrenal crisis in infants with salt-wasting forms of CAH being the most urgent medical issue. Thereafter, management decisions regarding the sex of rearing must consider a great many interacting and sometimes conflicting factors. Recent years have witnessed a growing appreciation for the complexities of psychosexual development, which reflects the influence of genes, societal and cultural norms, and family dynamics, and the effects of prenatal androgen exposure on sexual differentiation of the brain. Consequently, the wisdom of traditional management paradigms, in which sex assignment has been based primarily on the potential for reproduction and traditional sexual function, has come into question.<sup>589,590,591</sup>

## Stabilization

**CAH is the most common cause of 46,XX disorders of sexual development, one of the causes of 46,XY disorders of sexual development, and can be life-threatening. Consequently, infants with ambiguous genitalia and no palpable gonads should be assumed to have CAH and treated empirically until the diagnosis is confirmed or excluded.** If CAH is not promptly and effectively treated, hypoglycemia and symptoms of salt wasting (vomiting, diarrhea, hypovolemia, hyperkalemia, and cardiovascular collapse) can occur anytime within the first few days and weeks of life. The treatment of infants with classical forms of CAH is described in detail in an earlier section of this chapter and is only summarized here. Initial treatment includes fluid administration (5% dextrose in 0.9% saline), correction of any electrolyte abnormalities, and administration of stress doses of steroids. Patients with a confirmed diagnosis of CAH will require careful monitoring of electrolytes (hyperkalemia usually is the first indication of impending adrenal crisis), prompt treatment with adequate doses of hydrocortisone (which has some mineralocorticoid activity), and treatment with mineralocorticoids once stable and feeding normally.

## Family Counseling

Initial discussions should focus on helping the parents to gain a basic understanding of the causes of ambiguous genitalia, first explaining that the genitalia are not fully formed or are overdeveloped, and providing additional, more detailed information in accordance with the family's intellectual and emotional capacity and considering their cultural and religious background. Until the diagnosis and sex of rearing have been

established, birth announcements describing gender should be postponed, requiring careful and sensitive counseling. If the family inquires, matters relating to long-term reproductive function and sexuality should be discussed openly and frankly.

## Gender Decisions

In some cases, the decision is relatively straightforward, such as in mildly virilized girls with CAH. However, in many, the influence of sex assignment and rearing on ultimate gender identity cannot be predicted confidently, primarily because there are few data regarding long-term outcomes to guide the decision.<sup>592,593,594</sup>

**Traditional approaches have focused on early gender assignment and reconstructive surgery, but many now advocate postponing surgery until the patient can participate in the decision, when possible.**<sup>595</sup> The traditional approach was based on the assumptions that gender identity reflects gender assignment and the sex of rearing and can be imposed; that preservation of fertility (if possible), sexual function, and appearance should be the primary goals; and that a good anatomical result will translate to a healthy adaptation and patient satisfaction. Consequently, virilized female infants were assigned a female sex and underwent staged genital reconstruction during infancy, and undervirilized boys often were managed similarly, based on judgments regarding the feasibility of constructing a penile urethra.<sup>596</sup> These traditional principles were promulgated by the American Academy of Pediatrics as recently as 2000,<sup>597</sup> but an international (American and European) consensus conference conducted in 2006 has questioned their wisdom,<sup>115</sup> citing the lack of evidence that early genital surgery effectively reinforces gender assignment or influences gender identity or that genital appearance directs gender role decisions in adults. Vocal advocates have argued passionately that reconstructive surgery should be delayed until the patient can participate in the decision, but whether most affected adults agree is unknown.

Available data from long-term studies reflecting the traditional approach to gender assignment must be interpreted cautiously, because many of the most discontented affected adults may have declined to participate. Studies involving patients who had early feminizing surgery indicate that many had a poor cosmetic result and most required further surgery<sup>598</sup> and that sexual dysfunction is common among women who underwent clitoral surgery as infants or children.<sup>599</sup> Surgical techniques have improved,<sup>600,601</sup> but long-term outcomes remain uncertain. Two studies of long-term psychosocial outcomes in patients with 46,XY DSD found that half were living as men and half as women and that the two groups did not differ in satisfaction with their appearance, function, or sex of rearing.<sup>451,602</sup> Most patients assigned a female gender were satisfied with their sex of rearing, but only half had exclusively heterosexual

interests. Overall, half felt they did not have adequate information about their medical histories.<sup>451,602</sup> Whereas these data suggest that early gender assignment based on appearance usually results in a healthy psychosocial adjustment and outcome, the studies focused primarily on patients having limited potential for virilization. In contrast, patients having significant potential for virilization, such as those with steroid 5 $\alpha$ -reductase or 17 $\beta$ -hydroxysteroid dehydrogenase deficiencies, do not readily accept female gender assignment.<sup>603</sup>

Currently, there are no universally accepted guidelines for gender assignment. The Consensus Statement on the Management of Intersex Disorders offered numerous specific conclusions and recommendations.<sup>115</sup> Guidelines published by another group separate decisions regarding gender assignment from those regarding genital surgery.<sup>604</sup> The Intersex Society of North America, a peer support, education, and advocacy group founded and operated by and for intersexuals also has published recommendations, emphasizing the importance of avoiding harmful or unnecessary surgery, qualified professional mental health care for the child and family, and empowering patients by helping them to understand their condition and to choose or decline medical interventions.

Although expert opinions and recommendations vary, the guiding principles can be summarized as follows:

- Gender assignment and sex of rearing should be based on the most probable adult gender identity and the potential for adult function.
- Decisions should respect the family's own values and preferences.
- Children should be raised in the predicted and selected gender role but should also participate actively in longer-term gender decisions.

There is general agreement on some issues. Almost all virilized 46,XX children with CAH should be raised as females, primarily because more than 90% identify as females as adults, and 46,XX infants having essentially normal male external genitalia probably should be raised as males. When female gender is assigned, clitoral surgery probably is best delayed until the child expresses gender identity and can participate in the decision. When male gender is assigned, phallic reconstruction can be performed at a time acceptable to the family and to the surgeon while still permitting a later change in gender decision by the adult patient. Finally, purely cosmetic surgery should be postponed until the patient can participate in the decision.

## **Long-Term Care**

Patients with DSD and their families should receive ongoing support to help in their

psychosexual development. Support groups offer many affected patients useful information and insights and include the Intersex Society of North America ([www.isna.org](http://www.isna.org)), the Androgen Insensitivity Syndrome Support Group ([www.aissg.org](http://www.aissg.org)), Bodies Like Ours ([www.bodieslikeours.org](http://www.bodieslikeours.org)), and The Magic Foundation ([www.magicfoundation.org](http://www.magicfoundation.org)).

Patients having all or part of a Y chromosome whose gonads are located in the abdomen are at significant risk for developing a gonadal tumor. Consequently, they should be removed or, when possible and appropriate, moved to the scrotum, soon after diagnosis, except in those with complete AIS, in whom surgery generally is best postponed until after puberty.

Long-term care also must consider the potential effects of sex steroid exposure, the possibility and effects of a changing hormone environment at puberty, and the need for timely and effective sex steroid therapy.



# REFERENCES

1. **Jost A**, Hormonal factors in the sex differentiation of the mammalian foetus, *Philos Trans R Soc Lond B Biol Sci* 259:119, 1970.
2. **Money J, Schwartz M, Lewis VG**, Adult erotosexual status and fetal hormonal masculinization and demasculinization: 46,XX congenital virilizing adrenal hyperplasia and 46,XY androgen-insensitivity syndrome compared, *Psychoneuroendocrinology* 9:405, 1984.
3. **Mulaikal RM, Migeon CJ, Rock JA**, Fertility rates in female patients with congenital adrenal hyperplasia due to 21-hydroxylase deficiency, *N Engl J Med* 316:178, 1987.
4. **Dittmann RW, Kappes ME, Kappes MH**, Sexual behavior in adolescent and adult females with congenital adrenal hyperplasia, *Psychoneuroendocrinology* 17:153, 1992.
5. **Kuhle U, Bullinger M, Schwarz HP, Knorr D**, Partnership and sexuality in adult female patients with congenital adrenal hyperplasia. First results of a cross-sectional quality-of-life evaluation, *J Steroid Biochem Mol Biol* 45:123, 1993.
6. **Meyer-Bahlburg HF, Gruen RS, New MI, Bell JJ, Morishima A, Shimshi M, Bueno Y, Vargas I, Baker SW**, Gender change from female to male in classical congenital adrenal hyperplasia, *Horm Behav* 30:319, 1996.
7. **Rubinow DR, Schmidt PJ**, Androgens, brain, and behavior, *Am J Psychiatry* 153:974, 1996.
8. **Skaletsky H, Kuroda-Kawaguchi T, Minx PJ, Cordum HS, Hillier L, Brown LG, Repping S, Pyntikova T, Ali J, Bieri T, Chinwalla A, Delehaunty A, Delehaunty K, Du H, Fewell G, Fulton L, Fulton R, Graves T, Hou SF, Latrielle P, Leonard S, Mardis E, Maupin R, McPherson J, Miner T, Nash W, Nguyen C, Ozersky P, Pepin K, Rock S, Rohlfling T, Scott K, Schultz B, Strong C, Tin-Wollam A, Yang SP, Waterston RH, Wilson RK, Rozen S, Page DC**, The male-specific region of the human Y chromosome is a mosaic of discrete sequence classes, *Nature* 423:825, 2003.
9. **Fleming A, Vilain E**, The endless quest for sex determination genes, *Clin Genet* 67:15, 2005.
10. **Wilhelm D, Palmer S, Koopman P**, Sex determination and gonadal development in mammals, *Physiol Rev* 87:1, 2007.
11. **Matzuk MM, Lamb DJ**, The biology of infertility: research advances and clinical challenges, *Nat Med* 14:1197, 2008.
12. **Quintana-Murci L, Fellous M**, The human Y chromosome: the biological role of a “functional wasteland”, *J Biomed Biotechnol* 1:18, 2001.
13. **Sinclair AH, Berta P, Palmer MS, Hawkins JR, Griffiths BL, Smith JJ, Foster JW, Frischauf A-M, Lovell-Badge R, Goodfellow PN**, A gene from the human sex-determining region encodes a protein with homology to a conserved DNA-binding motif, *Nature* 346:240, 1990.
14. **Palmer MS, Sinclair AH, Berta P, Ellis NA, Goodfellow PN, Abbas NE, Fellous M**, Genetic evidence that ZFY is not the testis-determining factor, *Nature* 342:937, 1989.
15. **Berta P, Hawkins JR, Sinclair AH, Taylor A, Griffiths BL, Goodfellow PN, Fellous M**, Genetic evidence equating SRY and the testis-determining factor, *Nature* 348:448, 1990.
16. **Jager RJ, Anvret M, Hall K, Scherer G**, A human XY female with a frame shift mutation in the candidate testis-determining gene SRY, *Nature* 348:452, 1990.
17. **Gubbay J, Koopman P, Collignon J, Burgoyne P, Lovell-Badge R**, Normal structure and expression of Zfy genes in XY female mice mutant in Tdy, *Development* 109:647, 1990.
18. **Koopman P, Munsterberg A, Capel B, Vivian N, Lovell-Badge R**, Expression of a candidate sex-determining gene during mouse testis differentiation, *Nature* 348:450, 1990.
19. **Koopman P, Gubbay J, Vivian N, Goodfellow P, Lovell-Badge R**, Male development of chromosomally female mice transgenic for Sry, *Nature* 351:117, 1991.
20. **Harley VR, Clarkson MJ, Argentaro A**, The molecular action and regulation of the testis-determining factors, SRY (sex-determining region on the Y chromosome) and SOX9 [SRY-related high-mobility group (HMG) box 9], *Endocr Rev* 24:466, 2003.

21. **Smith M**, The year in human and medical genetics. Highlights of 2007–2008, *Ann N Y Acad Sci* 1151:1, 2009.
22. **Pilon N, Daneau I, Paradis V, Hamel F, Lussier JG, Viger RS, Silversides DW**, Porcine SRY promoter is a target for steroidogenic factor 1, *Biol Reprod* 68:1098, 2003.
23. **Correa RV, Domenice S, Bingham NC, Billerbeck AE, Rainey WE, Parker KL, Mendonca BB**, A microdeletion in the ligand binding domain of human steroidogenic factor 1 causes XY sex reversal without adrenal insufficiency, *J Clin Endocrinol Metab* 89:1767, 2004.
24. **Mallet D, Bretones P, Michel-Calemard L, Dijoud F, David M, Morel Y**, Gonadal dysgenesis without adrenal insufficiency in a 46, XY patient heterozygous for the nonsense C16X mutation: a case of SF1 haploinsufficiency, *J Clin Endocrinol Metab* 89:4829, 2004.
25. **Lin L, Philibert P, Ferraz-de-Souza B, Kelberman D, Homfray T, Albanese A, Molini V, Sebire NJ, Einaudi S, Conway GS, Hughes IA, Jameson JL, Sultan C, Dattani MT, Achermann JC**, Heterozygous missense mutations in steroidogenic factor 1 (SF1/Ad4BP, NR5A1) are associated with 46,XY disorders of sex development with normal adrenal function, *J Clin Endocrinol Metab* 92:991, 2007.
26. **Ozisk G, Achermann JC, Meeks JJ, Jameson JL**, SF1 in the development of the adrenal gland and gonads, *Horm Res* 59(Suppl 1):94, 2003.
27. **Wada Y, Okada M, Hasegawa T, Ogata T**, Association of severe micropenis with Gly146Ala polymorphism in the gene for steroidogenic factor-1, *Endocr J* 52:445, 2005.
28. **Wada Y, Okada M, Fukami M, Sasagawa I, Ogata T**, Association of cryptorchidism with Gly146Ala polymorphism in the gene for steroidogenic factor-1, *Fertil Steril* 85:787, 2006.
29. **Miyamoto Y, Taniguchi H, Hamel F, Silversides DW, Viger RS**, A GATA4/WT1 cooperation regulates transcription of genes required for mammalian sex determination and differentiation, *BMC Mol Biol* 9:44, 2008.
30. **Kanemoto K, Ishikura K, Ariyasu D, Hamasaki Y, Hataya H, Hasegawa Y, Ikeda M**, WT1 intron 9 splice acceptor site mutation in a 46,XY male with focal segmental glomerulosclerosis, *Pediatr Nephrol* 22:454, 2007.
31. **Kocer A, Reichmann J, Best D, Adams IR**, Germ cell sex determination in mammals, *Mol Hum Reprod* 15:205, 2009.
32. **Sekido R, Lovell-Badge R**, Sex determination and SRY: down to a wink and a nudge?, *Trends Genet* 25:19, 2009.
33. **Sekido R, Bar I, Narvaez V, Penny G, Lovell-Badge R**, SOX9 is up-regulated by the transient expression of SRY specifically in Sertoli cell precursors, *Dev Biol* 274:271, 2004.
34. **Wilhelm D, Martinson F, Bradford S, Wilson MJ, Combes AN, Beverdam A, Bowles J, Mizusaki H, Koopman P**, Sertoli cell differentiation is induced both cell-autonomously and through prostaglandin signaling during mammalian sex determination, *Dev Biol* 287:111, 2005.
35. **Chaboissier MC, Kobayashi A, Vidal VI, Lutzkendorf S, van de Kant HJ, Wegner M, de Rooij DG, Behringer RR, Schedl A**, Functional analysis of Sox8 and Sox9 during sex determination in the mouse, *Development* 131:1891, 2004.
36. **Barrionuevo F, Bagheri-Fam S, Klattig J, Kist R, Taketo MM, Englert C, Scherer G**, Homozygous inactivation of Sox9 causes complete XY sex reversal in mice, *Biol Reprod* 74:195, 2006.
37. **Ito M, Yu R, Jameson JL**, DAX-1 inhibits SF-1-mediated transactivation via a carboxy-terminal domain that is deleted in adrenal hypoplasia congenita, *Mol Cell Biol* 17:1476, 1997.
38. **Smyk M, Berg JS, Pursley A, Curtis FK, Fernandez BA, Bien-Willner GA, Lupski JR, Cheung SW, Stankiewicz P**, Male-to-female sex reversal associated with an approximately 250 kb deletion upstream of NR0B1 (DAX1), *Hum Genet* 122:63, 2007.
39. **Kim Y, Kobayashi A, Sekido R, DiNapoli L, Brennan J, Chaboissier MC, Poulat F, Behringer RR, Lovell-Badge R, Capel B**, Fgf9 and Wnt4 act as antagonistic signals to regulate mammalian sex determination, *PLoS Biol* 4:e187, 2006.
40. **Colvin JS, Green RP, Schmahl J, Capel B, Ornitz DM**, Male-to-female sex reversal in mice lacking fibroblast growth factor 9, *Cell* 104:875, 2001.
41. **Jeays-Ward K, Hoyle C, Brennan J, Dandonneau M, Alldus G, Capel B, Swain A**, Endothelial and steroidogenic cell migration are regulated by WNT4 in the developing mammalian gonad, *Development*

130:3663, 2003.

42. **Parma P, Radi O, Vidal V, Chaboissier MC, Dellambra E, Valentini S, Guerra L, Schedl A, Camerino G**, R-spondin1 is essential in sex determination, skin differentiation and malignancy, *Nat Genet* 38:1304, 2006.
43. **Chassot AA, Ranc F, Gregoire EP, Roepers-Gajadien HL, Taketo MM, Camerino G, de Rooij DG, Schedl A, Chaboissier MC**, Activation of beta-catenin signaling by Rspo1 controls differentiation of the mammalian ovary, *Hum Mol Genet* 17:1264, 2008.
44. **Tomizuka K, Horikoshi K, Kitada R, Sugawara Y, Iba Y, Kojima A, Yoshitome A, Yamawaki K, Amagai M, Inoue A, Oshima T, Kakitani M**, R-spondin1 plays an essential role in ovarian development through positively regulating Wnt-4 signaling, *Hum Mol Genet* 17:1278, 2008.
45. **Schmidt D, Ovitt CE, Anlag K, Fehsenfeld S, Gredsted L, Treier AC, Treier M**, The murine winged-helix transcription factor Foxl2 is required for granulosa cell differentiation and ovary maintenance, *Development* 131:933, 2004.
46. **Uhlenhaut NH, Treier M**, Foxl2 function in ovarian development, *Mol Genet Metab* 88:225, 2006.
47. **Ottolenghi C, Pelosi E, Tran J, Colombino M, Douglass E, Nedorezov T, Cao A, Forabosco A, Schlessinger D**, Loss of Wnt4 and Foxl2 leads to female-to-male sex reversal extending to germ cells, *Hum Mol Genet* 16:2795, 2007.
48. **Maatouk DM, DiNapoli L, Alvers A, Parker KL, Taketo MM, Capel B**, Stabilization of beta-catenin in XY gonads causes male-to-female sex-reversal, *Hum Mol Genet* 17:2949, 2008.
49. **Chang H, Gao F, Guillou F, Taketo MM, Huff V, Behringer RR**, Wt1 negatively regulates beta-catenin signaling during testis development, *Development* 135:1875, 2008.
50. **Cool J, Capel B**, Mixed signals: development of the testis, *Semin Reprod Med* 27:5, 2009.
51. **Bendel-Stenzel M, Anderson R, Heasman J, Wylie C**, The origin and migration of primordial germ cells in the mouse, *Semin Cell Dev Biol* 9:393, 1998.
52. **Merchant H**, Rat gonadal and ovarian organogenesis with and without germ cells. An ultrastructural study, *Dev Biol* 44:1, 1975.
53. **McLaren A**, Development of the mammalian gonad: the fate of the supporting cell lineage, *Bioessays* 13:151, 1991.
54. **Palmer SJ, Burgoyne PS**, In situ analysis of fetal, prepuberal and adult XX—XY chimaeric mouse testes: Sertoli cells are predominantly, but not exclusively, XY, *Development* 112:265, 1991.
55. **Koubova J, Menke DB, Zhou Q, Capel B, Griswold MD, Page DC**, Retinoic acid regulates sex-specific timing of meiotic initiation in mice, *Proc Natl Acad Sci U S A* 103:2474, 2006.
56. **Bowles J, Koopman P**, Retinoic acid, meiosis and germ cell fate in mammals, *Development* 134:3401, 2007.
57. **Best D, Sahlender DA, Walther N, Peden AA, Adams IR**, Sdmgl is a conserved transmembrane protein associated with germ cell sex determination and germline-soma interactions in mice, *Development* 135:1415, 2008.
58. **Johnson J, Canning J, Kaneko T, Pru JK, Tilly JL**, Germline stem cells and follicular renewal in the postnatal mammalian ovary, *Nature* 428:145, 2004.
59. **Johnson J, Bagley J, Skaznik-Wikiel M, Lee HJ, Adams GB, Niikura Y, Tschudy KS, Tilly JC, Cortes ML, Forkert R, Spitzer T, Iacomini J, Scadden DT, Tilly JL**, Oocyte generation in adult mammalian ovaries by putative germ cells in bone marrow and peripheral blood, *Cell* 122:303, 2005.
60. **Johnson J, Skaznik-Wikiel M, Lee HJ, Niikura Y, Tilly JC, Tilly JL**, Setting the record straight on data supporting postnatal oogenesis in female mammals, *Cell Cycle* 4:1471, 2005.
61. **Eggan K, Jurga S, Gosden R, Min IM, Wagers AJ**, Ovulated oocytes in adult mice derive from non-circulating germ cells, *Nature* 441:1109, 2006.
62. **Powell K**, Born or made? Debate on mouse eggs reignites, *Nature* 441:795, 2006.
63. **Lee HJ, Selesniemi K, Niikura Y, Niikura T, Klein R, Dombkowski DM, Tilly JL**, Bone marrow transplantation generates immature oocytes and rescues long-term fertility in a preclinical mouse model of chemotherapy-induced premature ovarian failure, *J Clin Oncol* 25:3198, 2007.
64. **Liu Y, Wu C, Lyu Q, Yang D, Albertini DF, Keefe DL, Liu L**, Germline stem cells and neo-oogenesis in the adult human ovary, *Dev Biol* 306:112, 2007.

65. **Veitia RA, Gluckman E, Fellous M, Soulier J**, Recovery of female fertility after chemotherapy, irradiation, and bone marrow allograft: further evidence against massive oocyte regeneration by bone marrow-derived germline stem cells, *Stem Cells* 25:1334, 2007.
66. **Tilly JL, Johnson J**, Recent arguments against germ cell renewal in the adult human ovary: is an absence of marker gene expression really acceptable evidence of an absence of oogenesis?, *Cell Cycle* 6:879, 2007.
67. **Zou K, Yuan Z, Yang Z, Luo H, Sun K, Zhou L, Xiang J, Shi L, Yu Q, Zhang Y, Hou R, Wu J**, Production of offspring from a germline stem cell line derived from neonatal ovaries, *Nat Cell Biol* 11(5):631, 2009.
68. **Zhang H, Zheng W, Shen Y, Adhikari D, Ueno H, Liu K**, Experimental evidence showing that no mitotically active female germline progenitors exist in postnatal mouse ovaries, *Proc Natl Acad Sci U S A* 109:12580, 2012.
69. **Lei L, Spradling AC**, Female mice lack adult germ-line stem cells but sustain oogenesis using stable primordial follicles, *Proc Natl Acad Sci U S A* 110:8585, 2013.
70. **Gittens JE, Kidder GM**, Differential contributions of connexin37 and connexin43 to oogenesis revealed in chimeric reaggregated mouse ovaries, *J Cell Sci* 118:5071, 2005.
71. **Trombly DJ, Woodruff TK, Mayo KE**, Roles for transforming growth factor beta superfamily proteins in early folliculogenesis, *Semin Reprod Med* 27:14, 2009.
72. **Mullen RD, Wang Y, Liu B, Moore EL, Behringer RR**, Osterix function downstream of anti-Mullerian hormone signaling to regulate Mullerian duct regression, *Proc Natl Acad Sci U S A* 115:33, 2018.
73. **Dissen GA, Garcia-Rudaz C, Ojeda SR**, Role of neurotrophic factors in early ovarian development, *Semin Reprod Med* 27:24, 2009.
74. **Simon AM, Goodenough DA, Li E, Paul DL**, Female infertility in mice lacking connexin 37, *Nature* 385:525, 1997.
75. **Juneja SC, Barr KJ, Enders GC, Kidder GM**, Defects in the germ line and gonads of mice lacking connexin43, *Biol Reprod* 60:1263, 1999.
76. **Ackert CL, Gittens JE, O'Brien MJ, Eppig JJ, Kidder GM**, Intercellular communication via connexin43 gap junctions is required for ovarian folliculogenesis in the mouse, *Dev Biol* 233:258, 2001.
77. **Su YQ, Sugiura K, Eppig JJ**, Mouse oocyte control of granulosa cell development and function: paracrine regulation of cumulus cell metabolism, *Semin Reprod Med* 27:32, 2009.
78. **Juengel JL, McNatty KP**, The role of proteins of the transforming growth factor-beta superfamily in the intraovarian regulation of follicular development, *Hum Reprod Update* 11:143, 2005.
79. **Speert H**, *Obstetric & Gynecologic Milestones Illustrated*, The Parthenon Publishing Group, New York, 1996.
80. **Jost A, Vigier B, Prepin J, Perchellet JP**, Studies on sex differentiation in mammals, *Recent Prog Horm Res* 29:1, 1973.
81. **Zondek LH, Zondek T**, Ovarian hilar cells and testicular Leydig cells in anencephaly, *Biol Neonate* 43:211, 1983.
82. **Siiteri PK, Wilson JD**, Testosterone formation and metabolism during male sexual differentiation in the human embryo, *J Clin Endocrinol Metab* 38:113, 1974.
83. **Welsh M, Sharpe RM, Walker M, Smith LB, Saunders PT**, New insights into the role of androgens in wolffian duct stabilization in male and female rodents, *Endocrinology* 150:2472, 2009.
84. **Joseph A, Yao H, Hinton BT**, Development and morphogenesis of the Wolffian/epididymal duct, more twists and turns, *Dev Biol* 325:6, 2009.
85. **Lubarsky B, Krasnow MA**, Tube morphogenesis: making and shaping biological tubes, *Cell* 112:19, 2003.
86. **Kirby JL, Yang L, Labus JC, Hinton BT**, Characterization of fibroblast growth factor receptors expressed in principal cells in the initial segment of the rat epididymis, *Biol Reprod* 68:2314, 2003.
87. **Branford WW, Benson GV, Ma L, Maas RL, Potter SS**, Characterization of Hoxa-10/Hoxa-11 transheterozygotes reveals functional redundancy and regulatory interactions, *Dev Biol* 224:373, 2000.
88. **Podlasek CA, Seo RM, Clemens JQ, Ma L, Maas RL, Bushman W**, Hoxa-10 deficient male mice exhibit abnormal development of the accessory sex organs, *Dev Dyn* 214:1, 1999.
89. **Tomaszewski J, Joseph A, Archambeault D, Yao HH**, Essential roles of inhibin beta A in mouse epididymal coiling, *Proc Natl Acad Sci U S A* 104:11322, 2007.

90. **Tomsig JL, Turner TT**, Growth factors and the epididymis, *J Androl* 27:348, 2006.
91. **Klattig J, Englert C**, The Mullerian duct: recent insights into its development and regression, *Sex Dev* 1:271, 2007.
92. **Orvis GD, Behringer RR**, Cellular mechanisms of Mullerian duct formation in the mouse, *Dev Biol* 306:493, 2007.
93. **Kobayashi A, Shawlot W, Kania A, Behringer RR**, Requirement of *Lim1* for female reproductive tract development, *Development* 131:539, 2004.
94. **Torres M, Gomez-Pardo E, Dressler GR, Gruss P**, Pax-2 controls multiple steps of urogenital development, *Development* 121:4057, 1995.
95. **Mittag J, Winterhager E, Bauer K, Grummer R**, Congenital hypothyroid female *pax8*-deficient mice are infertile despite thyroid hormone replacement therapy, *Endocrinology* 148:719, 2007.
96. **Mendelsohn C, Lohnes D, Decimo D, Lufkin T, LeMeur M, Chambon P, Mark M**, Function of the retinoic acid receptors (RARs) during development (II). Multiple abnormalities at various stages of organogenesis in RAR double mutants, *Development* 120:2749, 1994.
97. **Picard JY, Josso N**, Purification of testicular anti müllerian hormone allowing direct visualization of the pure glycoprotein and determination of yield and purification factor, *Mol Cell Endocrinol* 34:23, 1984.
98. **Pepinsky RB, Sinclair LK, Chow EP, Mattaliano RJ, Manganaro TF, Donahoe PK, Cate RL**, Proteolytic processing of müllerian inhibiting substance produces a transforming growth factor-beta-like fragment, *J Biol Chem* 263:18961, 1988.
99. **Taguchi O, Cunha GR, Lawrence WD, Robboy SJ**, Timing and irreversibility of müllerian duct inhibition in the embryonic reproductive tract of the human male, *Dev Biol* 106:394, 1984.
100. **Imbeaud S, Faure E, Lamarre I, Mattei MG, di Clemente N, Tizard R, Carre-Eusebe D, Belville C, Tragethon L, Tonkin C, Nelson J, McAuliffe M, Bidart JM, Lababidi A, Josso N, Cate RL, Picard JY**, Insensitivity to anti-müllerian hormone due to a mutation in the human anti-müllerian hormone receptor, *Nat Genet* 11:382, 1995.
101. **Zhan Y, Fujino A, MacLaughlin DT, Manganaro TF, Szotek PP, Arango NA, Teixeira J, Donahoe PK**, Müllerian inhibiting substance regulates its receptor/SMAD signaling and causes mesenchymal transition of the coelomic epithelial cells early in Müllerian duct regression, *Development* 133:2359, 2006.
102. **Klattig J, Sierig R, Kruspe D, Besenbeck B, Englert C**, Wilms' tumor protein *Wt1* is an activator of the anti-Müllerian hormone receptor gene *Amhr2*, *Mol Cell Biol* 27:4355, 2007.
103. **Roberts LM, Visser JA, Ingraham HA**, Involvement of a matrix metalloproteinase in MIS-induced cell death during urogenital development, *Development* 129:1487, 2002.
104. **Hines M**, Early androgen influences on human neural and behavioural development, *Early Hum Dev* 84:805, 2008.
105. **Wallen K**, Hormonal influences on sexually differentiated behavior in nonhuman primates, *Front Neuroendocrinol* 26:7, 2005.
106. **Dittmann RW, Kappes MH, Kappes ME, Borger D, Meyer-Bahlburg HF, Stegner H, Willig RH, Wallis H**, Congenital adrenal hyperplasia. II: Gender-related behavior and attitudes in female salt-wasting and simple-virilizing patients, *Psychoneuroendocrinology* 15:421, 1990.
107. **Nordenstrom A, Servin A, Bohlin G, Larsson A, Wedell A**, Sex-typed toy play behavior correlates with the degree of prenatal androgen exposure assessed by *CYP21* genotype in girls with congenital adrenal hyperplasia, *J Clin Endocrinol Metab* 87:5119, 2002.
108. **Pasterski V, Hindmarsh P, Geffner M, Brook C, Brain C, Hines M**, Increased aggression and activity level in 3- to 11-year-old girls with congenital adrenal hyperplasia (CAH), *Horm Behav* 52:368, 2007.
109. **Hines M, Fane BA, Pasterski VL, Mathews GA, Conway GS, Brook C**, Spatial abilities following prenatal androgen abnormality: targeting and mental rotations performance in individuals with congenital adrenal hyperplasia, *Psychoneuroendocrinology* 28:1010, 2003.
110. **Mathews GA, Fane BA, Conway GS, Brook CG, Hines M**, Personality and congenital adrenal hyperplasia: possible effects of prenatal androgen exposure, *Horm Behav* 55:285, 2009.
111. **Meyer-Bahlburg HF, Dolezal C, Baker SW, New MI**, Sexual orientation in women with classical or non-

classical congenital adrenal hyperplasia as a function of degree of prenatal androgen excess, *Arch Sex Behav* 37:85, 2008.

112. **Hines M, Golombok S, Rust J, Johnston KJ, Golding J**, Testosterone during pregnancy and gender role behavior of preschool children: a longitudinal, population study, *Child Dev* 73:1678, 2002.
113. **Auyeung B, Baron-Cohen S, Ashwin E, Knickmeyer R, Taylor K, Hackett G, Hines M**, Fetal testosterone predicts sexually differentiated childhood behavior in girls and in boys, *Psychol Sci* 20:144, 2009.
114. **Ernst M, Maheu FS, Schroth E, Hardin J, Golan LG, Cameron J, Allen R, Holzer S, Nelson E, Pine DS, Merke DP**, Amygdala function in adolescents with congenital adrenal hyperplasia: a model for the study of early steroid abnormalities, *Neuropsychologia* 45:2104, 2007.
115. **Lee PA, Houk CP, Ahmed SF, Hughes IA**, Consensus statement on management of intersex disorders. International Consensus Conference on Intersex, *Pediatrics* 118:e488, 2006.
116. **Krob G, Braun A, Kuhnle U**, True hermaphroditism: geographical distribution, clinical findings, chromosomes and gonadal histology, *Eur J Pediatr* 153: 2, 1994.
117. **Yordam N, Alikasifoglu A, Kandemir N, Caglar M, Balci S**, True hermaphroditism: clinical features, genetic variants and gonadal histology, *J Pediatr Endocrinol Metab* 14:421, 2001.
118. **Berkovitz GD, Fechner PY, Marcantonio SM, Bland G, Stetten G, Goodfellow PN, Smith KD, Migeon CJ**, The role of the sex-determining region of the Y chromosome (SRY) in the etiology of 46,XX true hermaphroditism, *Hum Genet* 88:411, 1992.
119. **Tomaselli S, Megiorni F, De Bernardo C, Felici A, Marrocco G, Maggiulli G, Grammatico B, Remotti D, Saccucci P, Valentini F, Mazzilli MC, Majore S, Grammatico P**, Syndromic true hermaphroditism due to an R-spondin1 (RSPO1) homozygous mutation, *Hum Mutat* 29:220, 2008.
120. **de la Chapelle A, Hortling H, Niemi M, Wennstroem J**, XX sex chromosomes in a human male. First case, *Acta Med Scand* 175(Suppl 412):25, 1964.
121. **Ergun-Longmire B, Vinci G, Alonso L, Matthew S, Tansil S, Lin-Su K, McElreavey K, New MI**, Clinical, hormonal and cytogenetic evaluation of 46,XX males and review of the literature, *J Pediatr Endocrinol Metab* 18:739, 2005.
122. **Domenice S, Correa RV, Costa EM, Nishi MY, Vilain E, Arnhold IJ, Mendonca BB**, Mutations in the SRY, DAX1, SF1 and WNT4 genes in Brazilian sex-reversed patients, *Braz J Med Biol Res* 37:145, 2004.
123. **Rajender S, Rajani V, Gupta NJ, Chakravarty B, Singh L, Thangaraj K**, SRY-negative 46,XX male with normal genitals, complete masculinization and infertility, *Mol Hum Reprod* 12:341, 2006.
124. **Wang T, Liu JH, Yang J, Chen J, Ye ZQ**, 46, XX male sex reversal syndrome: a case report and review of the genetic basis, *Andrologia* 41:59, 2009.
125. **Kusz K, Kotecki M, Wojda A, Szarras-Czapnik M, Latos-Bielenska A, Warenik-Szymankiewicz A, Ruszczynska-Wolska A, Jaruzelska J**, Incomplete masculinisation of XX subjects carrying the SRY gene on an inactive X chromosome, *J Med Genet* 36:452, 1999.
126. **Dardis A, Saraco N, Mendilaharsu H, Rivarola M, Belgorosky A**, Report of an XX male with hypospadias and pubertal gynecomastia, SRY gene negative in blood leukocytes but SRY gene positive in testicular cells, *Horm Res* 47:85, 1997.
127. **Huang B, Wang S, Ning Y, Lamb AN, Bartley J**, Autosomal XX sex reversal caused by duplication of SOX9, *Am J Med Genet* 87:349, 1999.
128. **Simpson JL**, Genetic and phenotypic heterogeneity in ovarian failure: overview of selected candidate genes, *Ann N Y Acad Sci* 1135:146, 2008.
129. **Witchel SF, Nayak S, Suda-Hartman M, Lee PA**, Newborn screening for 21-hydroxylase deficiency: results of CYP21 molecular genetic analysis, *J Pediatr* 131:328, 1997.
130. **Allen DB, Hoffman GL, Fitzpatrick P, Laessig R, Maby S, Slyper A**, Improved precision of newborn screening for congenital adrenal hyperplasia using weight-adjusted criteria for 17-hydroxyprogesterone levels, *J Pediatr* 130:128, 1997.
131. **Gruneiro-Papendieck L, Prieto L, Chiesa A, Bengolea S, Bossi G, Bergada C**, Neonatal screening program for congenital adrenal hyperplasia: adjustments to the recall protocol, *Horm Res* 55:271, 2001.
132. **Therrell BL**, Newborn screening for congenital adrenal hyperplasia, *Endocrinol Metab Clin North Am* 30:15,

2001.

133. **Lee HH, Kuo JM, Chao HT, Lee YJ, Chang JG, Tsai CH, Chung BC**, Carrier analysis and prenatal diagnosis of congenital adrenal hyperplasia caused by 21-hydroxylase deficiency in Chinese, *J Clin Endocrinol Metab* 85:597, 2000.
134. **New MI, White PC**, Genetic disorders of steroid hormone synthesis and metabolism, *Baillieres Clin Endocrinol Metab* 9:525, 1995.
135. **Cutfield WS, Webster D**, Newborn screening for congenital adrenal hyperplasia in New Zealand, *J Pediatr* 126:118, 1995.
136. **Pang S, Murphey W, Levine LS, Spence DA, Leon A, LaFranchi S, Surve AS, New MI**, A pilot newborn screening for congenital adrenal hyperplasia in Alaska, *J Clin Endocrinol Metab* 55:413, 1982.
137. **Therrell BL, Jr., Berenbaum SA, Manter-Kapanke V, Simmank J, Korman K, Prentice L, Gonzalez J, Gunn S**, Results of screening 1.9 million Texas newborns for 21-hydroxylase-deficient congenital adrenal hyperplasia, *Pediatrics* 101:583, 1998.
138. **Ferenczi A, Garami M, Kiss E, Pek M, Sasvari-Szekely M, Barta C, Staub M, Solyom J, Fekete G**, Screening for mutations of 21-hydroxylase gene in Hungarian patients with congenital adrenal hyperplasia, *J Clin Endocrinol Metab* 84:2369, 1999.
139. **White PC, Speiser PW**, Congenital adrenal hyperplasia due to 21-hydroxylase deficiency, *Endocr Rev* 21:245, 2000.
140. **Tiitinen A, Valimaki M**, Primary infertility in 45-year-old man with untreated 21-hydroxylase deficiency: successful outcome with glucocorticoid therapy, *J Clin Endocrinol Metab* 87:2442, 2002.
141. **Baumgartner-Parzer SM, Nowotny P, Heinze G, Waldhausl W, Vierhapper H**, Carrier frequency of congenital adrenal hyperplasia (21-hydroxylase deficiency) in a middle European population, *J Clin Endocrinol Metab* 90:775, 2005.
142. **Carroll MC, Campbell RD, Porter RR**, Mapping of steroid 21-hydroxylase genes adjacent to complement component C4 genes in HLA, the major histocompatibility complex in man, *Proc Natl Acad Sci U S A* 82:521, 1985.
143. **White PC, Grossberger D, Onufer BJ, Chaplin DD, New MI, Dupont B, Strominger JL**, Two genes encoding steroid 21-hydroxylase are located near the genes encoding the fourth component of complement in man, *Proc Natl Acad Sci U S A* 82:1089, 1985.
144. **White PC, New MI, Dupont B**, Structure of human steroid 21-hydroxylase genes, *Proc Natl Acad Sci U S A* 83:5111, 1986.
145. **Higashi Y, Yoshioka H, Yamane M, Gotoh O, Fujii-Kuriyama Y**, Complete nucleotide sequence of two steroid 21-hydroxylase genes tandemly arranged in human chromosome: a pseudogene and a genuine gene, *Proc Natl Acad Sci U S A* 83:2841, 1986.
146. **Miller WL**, Gene conversions, deletions, and polymorphisms in congenital adrenal hyperplasia, *Am J Hum Genet* 42:4, 1988.
147. **Speiser PW, White PC**, Congenital adrenal hyperplasia, *N Engl J Med* 349:776, 2003.
148. **Miller WL**, Clinical review 54: Genetics, diagnosis, and management of 21-hydroxylase deficiency, *J Clin Endocrinol Metab* 78:241, 1994.
149. **L'Allemand D, Tardy V, Gruters A, Schnabel D, Krude H, Morel Y**, How a patient homozygous for a 30-kb deletion of the C4-CYP 21 genomic region can have a nonclassic form of 21-hydroxylase deficiency, *J Clin Endocrinol Metab* 85:4562, 2000.
150. **Lajic S, Clauin S, Robins T, Vexiau P, Blanche H, Bellanne-Chantelot C, Wedell A**, Novel mutations in CYP21 detected in individuals with hyperandrogenism, *J Clin Endocrinol Metab* 87:2824, 2002.
151. **Stikkelbroeck NM, Hoefsloot LH, de Wijs IJ, Otten BJ, Hermus AR, Sijm EA**, CYP21 gene mutation analysis in 198 patients with 21-hydroxylase deficiency in The Netherlands: six novel mutations and a specific cluster of four mutations, *J Clin Endocrinol Metab* 88:3852, 2003.
152. **Billerbeck AE, Mendonca BB, Pinto EM, Madureira G, Arnhold IJ, Bachega TA**, Three novel mutations in CYP21 gene in Brazilian patients with the classical form of 21-hydroxylase deficiency due to a founder effect, *J Clin Endocrinol Metab* 87:4314, 2002.

153. **Speiser PW, Dupont J, Zhu D, Serrat J, Buegeleisen M, Tusie-Luna MT, Lesser M, New MI, White PC**, Disease expression and molecular genotype in congenital adrenal hyperplasia due to 21-hydroxylase deficiency, *J Clin Invest* 90:584, 1992.
154. **Wedell A, Thilen A, Ritzen EM, Stengler B, Luthman H**, Mutational spectrum of the steroid 21-hydroxylase gene in Sweden: implications for genetic diagnosis and association with disease manifestation, *J Clin Endocrinol Metab* 78:1145, 1994.
155. **Wilson RC, Mercado AB, Cheng KC, New MI**, Steroid 21-hydroxylase deficiency: genotype may not predict phenotype, *J Clin Endocrinol Metab* 80:2322, 1995.
156. **Jaaskelainen J, Levo A, Voutilainen R, Partanen J**, Population-wide evaluation of disease manifestation in relation to molecular genotype in steroid 21-hydroxylase (CYP21) deficiency: good correlation in a well defined population, *J Clin Endocrinol Metab* 82:3293, 1997.
157. **Ordonez-Sanchez ML, Ramirez-Jimenez S, Lopez-Gutierrez AU, Riba L, Gamboa-Cardiel S, Cerrillo-Hinojosa M, Altamirano-Bustamante N, Calzada-Leon R, Robles-Valdes C, Mendoza-Morfin F, Tusie-Luna MT**, Molecular genetic analysis of patients carrying steroid 21-hydroxylase deficiency in the Mexican population: identification of possible new mutations and high prevalence of apparent germ-line mutations, *Hum Genet* 102:170, 1998.
158. **Higashi Y, Hiromasa T, Tanae A, Miki T, Nakura J, Kondo T, Ohura T, Ogawa E, Nakayama K, Fujii-Kuriyama Y**, Effects of individual mutations in the P-450(C21) pseudogene on the P-450(C21) activity and their distribution in the patient genomes of congenital steroid 21-hydroxylase deficiency, *J Biochem* 109:638, 1991.
159. **Mornet E, Crete P, Kuttenn F, Raux-Demay MC, Boue J, White PC, Boue A**, Distribution of deletions and seven point mutations on CYP21B genes in three clinical forms of steroid 21-hydroxylase deficiency, *Am J Hum Genet* 48:79, 1991.
160. **Owerbach D, Ballard AL, Draznin MB**, Salt-wasting congenital adrenal hyperplasia: detection and characterization of mutations in the steroid 21-hydroxylase gene, CYP21, using the polymerase chain reaction, *J Clin Endocrinol Metab* 74:553, 1992.
161. **Dardis A, Bergada I, Bergada C, Rivarola M, Belgorosky A**, Mutations of the steroid 21-hydroxylase gene in an Argentinian population of 36 patients with classical congenital adrenal hyperplasia, *J Pediatr Endocrinol Metab* 10:55, 1997.
162. **Krone N, Braun A, Roscher AA, Knorr D, Schwarz HP**, Predicting phenotype in steroid 21-hydroxylase deficiency? Comprehensive genotyping in 155 unrelated, well defined patients from southern Germany, *J Clin Endocrinol Metab* 85:1059, 2000.
163. **Deneux C, Tardy V, Dib A, Mornet E, Billaud L, Charron D, Morel Y, Kuttenn F**, Phenotype-genotype correlation in 56 women with nonclassical congenital adrenal hyperplasia due to 21-hydroxylase deficiency, *J Clin Endocrinol Metab* 86:207, 2001.
164. **Balsamo A, Cicognani A, Baldazzi L, Barbaro M, Baronio F, Gennari M, Bal M, Cassio A, Kontaxaki K, Cacciari E**, CYP21 genotype, adult height, and pubertal development in 55 patients treated for 21-hydroxylase deficiency, *J Clin Endocrinol Metab* 88:5680, 2003.
165. **Grigorescu Sido A, Weber MM, Grigorescu Sido P, Clausmeyer S, Heinrich U, Schulze E**, 21-Hydroxylase and 11beta-hydroxylase mutations in Romanian patients with classic congenital adrenal hyperplasia, *J Clin Endocrinol Metab* 90:5769, 2005.
166. **Gutai JP, Kowarski AA, Migeon CJ**, The detection of the heterozygous carrier for congenital virilizing adrenal hyperplasia, *J Pediatr* 90:924, 1977.
167. **Charmandari E, Merke DP, Negro PJ, Keil MF, Martinez PE, Haim A, Gold PW, Chrousos GP**, Endocrinologic and psychologic evaluation of 21-hydroxylase deficiency carriers and matched normal subjects: evidence for physical and/or psychologic vulnerability to stress, *J Clin Endocrinol Metab* 89:2228, 2004.
168. **White PC, New MI, Dupont B**, Congenital adrenal hyperplasia (1), *N Engl J Med* 316:1519, 1987.
169. **White PC, New MI, Dupont B**, Congenital adrenal hyperplasia (2), *N Engl J Med* 316:1580, 1987.
170. **New MI**, Female pseudohermaphroditism, *Semin Perinatol* 16:289, 1992.
171. **Berenbaum SA**, Cognitive function in congenital adrenal hyperplasia, *Endocrinol Metab Clin North Am*



30:173, 2001.

172. **Johannsen TH, Ripa CP, Reinisch JM, Schwartz M, Mortensen EL, Main KM**, Impaired cognitive function in women with congenital adrenal hyperplasia, *J Clin Endocrinol Metab* 91:1376, 2006.
173. **Nass R, Baker S**, Androgen effects on cognition: congenital adrenal hyperplasia, *Psychoneuroendocrinology* 16:189, 1991.
174. **Helleday J, Bartfai A, Ritzen EM, Forsman M**, General intelligence and cognitive profile in women with congenital adrenal hyperplasia (CAH), *Psychoneuroendocrinology* 19:343, 1994.
175. **Kelso WM, Nicholls ME, Warne GL, Zacharin M**, Cerebral lateralization and cognitive functioning in patients with congenital adrenal hyperplasia, *Neuropsychology* 14:370, 2000.
176. **Malouf MA, Migeon CJ, Carson KA, Petrucci L, Wisniewski AB**, Cognitive outcome in adult women affected by congenital adrenal hyperplasia due to 21-hydroxylase deficiency, *Horm Res* 65:142, 2006.
177. **Hagenfeldt K, Janson PO, Holmdahl G, Falhammar H, Filipsson H, Frisen L, Thoren M, Nordenskjold A**, Fertility and pregnancy outcome in women with congenital adrenal hyperplasia due to 21-hydroxylase deficiency, *Hum Reprod* 23:1607, 2008.
178. **Nordenskjold A, Holmdahl G, Frisen L, Falhammar H, Filipsson H, Thoren M, Janson PO, Hagenfeldt K**, Type of mutation and surgical procedure affect long-term quality of life for women with congenital adrenal hyperplasia, *J Clin Endocrinol Metab* 93:380, 2008.
179. **Stikkelbroeck NM, Hermus AR, Braat DD, Otten BJ**, Fertility in women with congenital adrenal hyperplasia due to 21-hydroxylase deficiency, *Obstet Gynecol Surv* 58:275, 2003.
180. **Lo JC, Schwitzgebel VM, Tyrrell JB, Fitzgerald PA, Kaplan SL, Conte FA, Grumbach MM**, Normal female infants born of mothers with classic congenital adrenal hyperplasia due to 21-hydroxylase deficiency, *J Clin Endocrinol Metab* 84:930, 1999.
181. **New MI, Lorenzen F, Lerner AJ, Kohn B, Oberfield SE, Pollack MS, Dupont B, Stoner E, Levy DJ, Pang S, Levine LS**, Genotyping steroid 21-hydroxylase deficiency: hormonal reference data, *J Clin Endocrinol Metab* 57:320, 1983.
182. **Tordjman K, Jaffe A, Trostanetsky Y, Greenman Y, Limor R, Stern N**, Low-dose (1 microgram) adrenocorticotrophin (ACTH) stimulation as a screening test for impaired hypothalamo-pituitary-adrenal axis function: sensitivity, specificity and accuracy in comparison with the high-dose (250 microgram) test, *Clin Endocrinol (Oxf)* 52:633, 2000.
183. **Nordenstrom A, Thilen A, Hagenfeldt L, Larsson A, Wedell A**, Genotyping is a valuable diagnostic complement to neonatal screening for congenital adrenal hyperplasia due to steroid 21-hydroxylase deficiency, *J Clin Endocrinol Metab* 84:1505, 1999.
184. **Olgemoller B, Roscher AA, Liebl B, Fingerhut R**, Screening for congenital adrenal hyperplasia: adjustment of 17-hydroxyprogesterone cut-off values to both age and birth weight markedly improves the predictive value, *J Clin Endocrinol Metab* 88:5790, 2003.
185. **van der Kamp HJ, Oudshoorn CG, Elvers BH, van Baarle M, Otten BJ, Wit JM, Verkerk PH**, Cutoff levels of 17-alpha-hydroxyprogesterone in neonatal screening for congenital adrenal hyperplasia should be based on gestational age rather than on birth weight, *J Clin Endocrinol Metab* 90:3904, 2005.
186. **Gatelais F, Berthelot J, Beringue F, Descamps P, Bonneau D, Limal JM, Coutant R**, Effect of single and multiple courses of prenatal corticosteroids on 17-hydroxyprogesterone levels: implication for neonatal screening of congenital adrenal hyperplasia, *Pediatr Res* 56:701, 2004.
187. **Fitness J, Dixit N, Webster D, Torresani T, Pergolizzi R, Speiser PW, Day DJ**, Genotyping of CYP21, linked chromosome 6p markers, and a sex-specific gene in neonatal screening for congenital adrenal hyperplasia, *J Clin Endocrinol Metab* 84:960, 1999.
188. **Azziz R, Dewailly D, Owerbach D**, Clinical review 56: nonclassic adrenal hyperplasia: current concepts, *J Clin Endocrinol Metab* 78:810, 1994.
189. **White PC, Curnow KM, Pascoe L**, Disorders of steroid 11 beta-hydroxylase isozymes, *Endocr Rev* 15:421, 1994.
190. **Zachmann M, Tassinari D, Prader A**, Clinical and biochemical variability of congenital adrenal hyperplasia due to 11 beta-hydroxylase deficiency. A study of 25 patients, *J Clin Endocrinol Metab* 56:222, 1983.

191. **Cathelineau G, Brerault JL, Fiet J, Julien R, Dreux C, Canivet J**, Adrenocortical 11 beta-hydroxylation defect in adult women with postmenarchial onset of symptoms, *J Clin Endocrinol Metab* 51:287, 1980.
192. **Lucky AW, Rosenfield RL, McGuire J, Rudy S, Helke J**, Adrenal androgen hyperresponsiveness to adrenocorticotropin in women with acne and/or hirsutism: adrenal enzyme defects and exaggerated adrenarche, *J Clin Endocrinol Metab* 62:840, 1986.
193. **de Simone G, Tommaselli AP, Rossi R, Valentino R, Lauria R, Scopacasa F, Lombardi G**, Partial deficiency of adrenal 11-hydroxylase. A possible cause of primary hypertension, *Hypertension* 7:204, 1985.
194. **Holcombe JH, Keenan BS, Nichols BL, Kirkland RT, Clayton GW**, Neonatal salt loss in the hypertensive form of congenital adrenal hyperplasia, *Pediatrics* 65:777, 1980.
195. **Hochberg Z, Benderly A, Kahana L, Zadik Z**, Requirement of mineralocorticoid in congenital adrenal hyperplasia due to 11 beta-hydroxylase deficiency, *J Clin Endocrinol Metab* 63:36, 1986.
196. **Rosler A, Leiberman E, Sack J, Landau H, Benderly A, Moses SW, Cohen T**, Clinical variability of congenital adrenal hyperplasia due to 11 beta-hydroxylase deficiency, *Horm Res* 16:133, 1982.
197. **Rosler A, Leiberman E, Cohen T**, High frequency of congenital adrenal hyperplasia (classic 11 beta-hydroxylase deficiency) among Jews from Morocco, *Am J Med Genet* 42:827, 1992.
198. **White PC, Dupont J, New MI, Leiberman E, Hochberg Z, Rosler A**, A mutation in CYP11B1 (Arg-448—His) associated with steroid 11 beta-hydroxylase deficiency in Jews of Moroccan origin, *J Clin Invest* 87:1664, 1991.
199. **Curnow KM, Slutsker L, Vitek J, Cole T, Speiser PW, New MI, White PC, Pascoe L**, Mutations in the CYP11B1 gene causing congenital adrenal hyperplasia and hypertension cluster in exons 6, 7, and 8, *Proc Natl Acad Sci U S A* 90:4552, 1993.
200. **Krone N, Riepe FG, Gotze D, Korsch E, Rister M, Commentz J, Partsch CJ, Grotzinger J, Peter M, Sippell WG**, Congenital adrenal hyperplasia due to 11-hydroxylase deficiency: functional characterization of two novel point mutations and a three-base pair deletion in the CYP11B1 gene, *J Clin Endocrinol Metab* 90:3724, 2005.
201. **Helmberg A, Ausserer B, Kofler R**, Frame shift by insertion of 2 basepairs in codon 394 of CYP11B1 causes congenital adrenal hyperplasia due to steroid 11 beta-hydroxylase deficiency, *J Clin Endocrinol Metab* 75:1278, 1992.
202. **Naiki Y, Kawamoto T, Mitsuuchi Y, Miyahara K, Toda K, Orii T, Imura H, Shizuta Y**, A nonsense mutation (TGG [Trp116] → TAG [Stop]) in CYP11B1 causes steroid 11 beta-hydroxylase deficiency, *J Clin Endocrinol Metab* 77:1677, 1993.
203. **Kuribayashi I, Massa G, van den Tooren-de Groot HK, Oostdijk W, Wit JM, Shizuta Y**, A novel nonsense mutation in the Cyp11B1 gene from a subject with the steroid 11beta-hydroxylase form of congenital adrenal hyperplasia, *Endocr Res* 29:377, 2003.
204. **Hampf M, Dao NT, Hoan NT, Bernhardt R**, Unequal crossing-over between aldosterone synthase and 11beta-hydroxylase genes causes congenital adrenal hyperplasia, *J Clin Endocrinol Metab* 86:4445, 2001.
205. **Portrat S, Mulatero P, Curnow KM, Chaussain JL, Morel Y, Pascoe L**, Deletion hybrid genes, due to unequal crossing over between CYP11B1 (11beta-hydroxylase) and CYP11B2(aldosterone synthase) cause steroid 11beta-hydroxylase deficiency and congenital adrenal hyperplasia, *J Clin Endocrinol Metab* 86:3197, 2001.
206. **Zhu YS, Cordero JJ, Can S, Cai LQ, You X, Herrera C, DeFillo-Ricart M, Shackleton C, Imperato-McGinley J**, Mutations in CYP11B1 gene: phenotype-genotype correlations, *Am J Med Genet A* 122A:193, 2003.
207. **Lashansky G, Saenger P, Fishman K, Gautier T, Mayes D, Berg G, Di Martino-Nardi J, Reiter E**, Normative data for adrenal steroidogenesis in a healthy pediatric population: age- and sex-related changes after adrenocorticotropin stimulation, *J Clin Endocrinol Metab* 73:674, 1991.
208. **Lashansky G, Saenger P, Dimartino-Nardi J, Gautier T, Mayes D, Berg G, Reiter E**, Normative data for the steroidogenic response of mineralocorticoids and their precursors to adrenocorticotropin in a healthy pediatric population, *J Clin Endocrinol Metab* 75:1491, 1992.
209. **Simard J, Ricketts ML, Gingras S, Soucy P, Feltus FA, Melner MH**, Molecular biology of the 3beta-

hydroxysteroid dehydrogenase/delta5-delta4 isomerase gene family, *Endocr Rev* 26:525, 2005.

210. **Rheaume E, Simard J, Morel Y, Mebarki F, Zachmann M, Forest MG, New MI, Labrie F**, Congenital adrenal hyperplasia due to point mutations in the type II 3 beta-hydroxysteroid dehydrogenase gene, *Nat Genet* 1:239, 1992.
211. **Simard J, Rheaume E, Leblanc JF, Wallis SC, Joplin GF, Gilbey S, Allanson J, Mettler G, Bettendorf M, Heinrich U**, et al., Congenital adrenal hyperplasia caused by a novel homozygous frameshift mutation 273 delta AA in type II 3 beta-hydroxysteroid dehydrogenase gene (HSD3B2) in three male patients of Afghan/Pakistani origin, *Hum Mol Genet* 3:327, 1994.
212. **Zhang L, Sakkal-Alkaddour H, Chang YT, Yang X, Pang S**, A new compound heterozygous frameshift mutation in the type II 3 beta-hydroxysteroid dehydrogenase (3 beta-HSD) gene causes salt-wasting 3 beta-HSD deficiency congenital adrenal hyperplasia, *J Clin Endocrinol Metab* 81:291, 1996.
213. **Katsumata N, Tanae A, Yasunaga T, Horikawa R, Tanaka T, Hibi I**, A novel missense mutation in the type II 3 beta-hydroxysteroid dehydrogenase gene in a family with classical salt-wasting congenital adrenal hyperplasia due to 3 beta-hydroxysteroid dehydrogenase deficiency, *Hum Mol Genet* 4:745, 1995.
214. **Rheaume E, Sanchez R, Mebarki F, Gagnon E, Carel JC, Chaussain JL, Morel Y, Labrie F, Simard J**, Identification and characterization of the G15D mutation found in a male patient with 3 beta-hydroxysteroid dehydrogenase (3 beta-HSD) deficiency: alteration of the putative NAD-binding domain of type II 3 beta-HSD, *Biochemistry* 34:2893, 1995.
215. **Sanchez R, Mebarki F, Rheaume E, Laflamme N, Forest MG, Bey-Omar F, David M, Morel Y, Labrie F, Simard J**, Functional characterization of the novel L108W and P186L mutations detected in the type II 3 beta-hydroxysteroid dehydrogenase gene of a male pseudohermaphrodite with congenital adrenal hyperplasia, *Hum Mol Genet* 3:1639, 1994.
216. **Simard J, Rheaume E, Sanchez R, Laflamme N, de Launoit Y, Luu-The V, van Seters AP, Gordon RD, Bettendorf M, Heinrich U**, et al., Molecular basis of congenital adrenal hyperplasia due to 3 beta-hydroxysteroid dehydrogenase deficiency, *Mol Endocrinol* 7:716, 1993.
217. **Zhang L, Mason JI, Naiki Y, Copeland KC, Castro-Magana M, Gordon-Walker TT, Chang YT, Pang S**, Characterization of two novel homozygous missense mutations involving codon 6 and 259 of type II 3beta-hydroxysteroid dehydrogenase (3betaHSD) gene causing, respectively, nonsalt-wasting and salt-wasting 3betaHSD deficiency disorder, *J Clin Endocrinol Metab* 85:1678, 2000.
218. **Rheaume E, Sanchez R, Simard J, Chang YT, Wang J, Pang S, Labrie F**, Molecular basis of congenital adrenal hyperplasia in two siblings with classical nonsalt-losing 3 beta-hydroxysteroid dehydrogenase deficiency, *J Clin Endocrinol Metab* 79:1012, 1994.
219. **Russell AJ, Wallace AM, Forest MG, Donaldson MD, Edwards CR, Sutcliffe RG**, Mutation in the human gene for 3 beta-hydroxysteroid dehydrogenase type II leading to male pseudohermaphroditism without salt loss, *J Mol Endocrinol* 12:225, 1994.
220. **Sanchez R, Rheaume E, Laflamme N, Rosenfield RL, Labrie F, Simard J**, Detection and functional characterization of the novel missense mutation Y254D in type II 3 beta-hydroxysteroid dehydrogenase (3 beta HSD) gene of a female patient with nonsalt-losing 3 beta HSD deficiency, *J Clin Endocrinol Metab* 78:561, 1994.
221. **Schram P, Zerah M, Mani P, Jewelewicz R, Jaffe S, New MI**, Nonclassical 3 $\beta$ -hydroxysteroid dehydrogenase deficiency: a review of our experience with 25 female patients, *Fertil Steril* 58:129, 1992.
222. **Azziz R, Bradley EL Jr, Potter HD, Boots LR**, 3 $\beta$ -Hydroxysteroid dehydrogenase deficiency in hyperandrogenism, *Am J Obstet Gynecol* 168:889, 1993.
223. **Zerah M, Rheaume E, Mani P, Schram P, Simard J, Labrie F, New MI**, No evidence of mutations in the genes for type I and type II 3 $\beta$ -hydroxysteroid dehydrogenase (3 $\beta$ -HSD) in nonclassic 3 $\beta$ -HSD deficiency, *J Clin Endocrinol Metab* 79:1811, 1994.
224. **Chang YT, Zhang L, Alkaddour HS, Mason JL, Lin K, Yang X, Garibaldi LR, Bourdony CJ, Dolan LM, Donaldson DL**, et al., Absence of molecular defect in the type II 3 $\beta$ -hydroxysteroid dehydrogenase (3 $\beta$ -HSD) gene in premature pubarche children and hirsute female patients with moderately decreased adrenal 3 $\beta$ -HSD activity, *Pediatr Res* 37:820, 1995.

225. **Marui S, Russell AJ, Paula FJA, Dick-de-Paula I, Marcondes JA, Mendonca BB**, Genotyping of the type II 3 $\beta$ -hydroxysteroid dehydrogenase gene (HSD3 $\beta$ 2) in women with hirsutism and elevated ACTH-stimulated delta5-steroids, *Fertil Steril* 74:553, 2000.
226. **Practice Committee of Society for Assisted Reproductive Technology; Practice Committee of American Society for Reproductive Medicine**, Preimplantation genetic testing: a Practice Committee opinion, *Fertil Steril* 90:S136, 2008.
227. **Van de Velde H, Sermon K, De Vos A, Lissens W, Joris H, Vandervorst M, Van Steirteghem A, Liebaers I**, Fluorescent PCR and automated fragment analysis in preimplantation genetic diagnosis for 21-hydroxylase deficiency in congenital adrenal hyperplasia, *Mol Hum Reprod* 5:691, 1999.
228. **Sullivan-Pyke C, Dokras A**, Preimplantation genetic screening and preimplantation genetic diagnosis, *Obstet Gynecol Clin North Am* 45:1, 2018.
229. **Clayton PE, Miller WL, Oberfield SE, Ritzén EM, Sippell WG, Speiser PW; ESPE/LWPES CAH Working Group**, Consensus statement on 21-hydroxylase deficiency from the Lawson Wilkins Pediatric Endocrine Society and the European Society for Paediatric Endocrinology, *J Clin Endocrinol Metab* 87:4048, 2002.
230. **Forest MG, Betuel H, David M**, Prenatal treatment in congenital adrenal hyperplasia due to 21-hydroxylase deficiency: up-date 88 of the French multicentric study, *Endocr Res* 15:277, 1989.
231. **Mercado AB, Wilson RC, Cheng KC, Wei J-Q, New MI**, Prenatal treatment and diagnosis of congenital adrenal hyperplasia owing to steroid 21-hydroxylase deficiency, *J Clin Endocrinol Metab* 80:2014, 1995.
232. **New MI, Carlson A, Obeid J, Marshall I, Cabrera MS, Goseco A, Lin-Su K, Putnam AS, Wei JQ, Wilson RC**, Prenatal diagnosis for congenital adrenal hyperplasia in 532 pregnancies, *J Clin Endocrinol Metab* 86:5651, 2001.
233. **Pang S, Clark AT, Freeman LC, Dolan LM, Immken L, Mueller OT, Stiff D, Shulman DI**, Maternal side effects of prenatal dexamethasone therapy for fetal congenital adrenal hyperplasia, *J Clin Endocrinol Metab* 75:249, 1992.
234. **Nimkarn S, New MI**, Prenatal diagnosis and treatment of congenital adrenal hyperplasia, *Horm Res* 67:53, 2007.
235. **Hirvikoski T, Nordenstrom A, Lindholm T, Lindblad F, Ritzen EM, Wedell A, Lajic S**, Cognitive functions in children at risk for congenital adrenal hyperplasia treated prenatally with dexamethasone, *J Clin Endocrinol Metab* 92:542, 2007.
236. **Merke DP, Bornstein SR**, Congenital adrenal hyperplasia, *Lancet* 365:2125, 2005.
237. **Kerrigan JR, Veldhuis JD, Leyo SA, Iranmanesh A, Rogol AD**, Estimation of daily cortisol production and clearance rates in normal pubertal males by deconvolution analysis, *J Clin Endocrinol Metab* 76:1505, 1993.
238. **Metzger DL, Wright NM, Veldhuis JD, Rogol AD, Kerrigan JR**, Characterization of pulsatile secretion and clearance of plasma cortisol in premature and term neonates using deconvolution analysis, *J Clin Endocrinol Metab* 77:458, 1993.
239. **Linder BL, Esteban NV, Yergey AL, Winterer JC, Loriaux DL, Cassorla F**, Cortisol production rate in childhood and adolescence, *J Pediatr* 117:892, 1990.
240. **Horrocks PM, London DR**, Effects of long term dexamethasone treatment in adult patients with congenital adrenal hyperplasia, *Clin Endocrinol (Oxf)* 27:635, 1987.
241. **Young MC, Hughes IA**, Dexamethasone treatment for congenital adrenal hyperplasia, *Arch Dis Child* 65:312, 1990.
242. **Punthakee Z, Legault L, Polychronakos C**, Prednisolone in the treatment of adrenal insufficiency: a re-evaluation of relative potency, *J Pediatr* 143:402, 2003.
243. **Rivkees SA, Crawford JD**, Dexamethasone treatment of virilizing congenital adrenal hyperplasia: the ability to achieve normal growth, *Pediatrics* 106:767, 2000.
244. **Lopes LA, Dubuis JM, Vallotton MB, Sizonenko PC**, Should we monitor more closely the dosage of 9 alpha-fluorohydrocortisone in salt-losing congenital adrenal hyperplasia?, *J Pediatr Endocrinol Metab* 11:733, 1998.
245. **Jansen M, Wit JM, van den Brande JL**, Reinstitution of mineralocorticoid therapy in congenital adrenal

- hyperplasia. Effects on control and growth, *Acta Paediatr Scand* 70:229, 1981.
246. **Schaison G, Couzinet B, Gourmelen M, Elkik F, Bougneres P**, Angiotensin and adrenal steroidogenesis: study of 21-hydroxylase-deficient congenital adrenal hyperplasia, *J Clin Endocrinol Metab* 51:1390, 1980.
  247. **Merke DP, Bornstein SR, Avila NA, Chrousos GP**, NIH conference. Future directions in the study and management of congenital adrenal hyperplasia due to 21-hydroxylase deficiency, *Ann Intern Med* 136:320, 2002.
  248. **Speiser PW**, Congenital adrenal hyperplasia owing to 21-hydroxylase deficiency, *Endocrinol Metab Clin North Am* 30:31, 2001.
  249. **Hughes IA**, Monitoring treatment in congenital adrenal hyperplasia, *Arch Dis Child* 65:333, 1990.
  250. **Soliman AT, AILamki M, AlSalmi I, Asfour M**, Congenital adrenal hyperplasia complicated by central precocious puberty: linear growth during infancy and treatment with gonadotropin-releasing hormone analog, *Metabolism* 46:513, 1997.
  251. **Jaaskelainen J, Voutilainen R**, Bone mineral density in relation to glucocorticoid substitution therapy in adult patients with 21-hydroxylase deficiency, *Clin Endocrinol (Oxf)* 45:707, 1996.
  252. **Eugster EA, Dimeglio LA, Wright JC, Freidenberg GR, Seshadri R, Pescovitz OH**, Height outcome in congenital adrenal hyperplasia caused by 21-hydroxylase deficiency: a meta-analysis, *J Pediatr* 138:26, 2001.
  253. **New MI, Gertner JM, Speiser PW, del Balzo P**, Growth and final height in classical and nonclassical 21-hydroxylase deficiency, *Acta Paediatr Jpn* 30(Suppl):79, 1988.
  254. **Rasat R, Espiner EA, Abbott GD**, Growth patterns and outcomes in congenital adrenal hyperplasia; effect of chronic treatment regimens, *N Z Med J* 108:311, 1995.
  255. **Young MC, Hughes IA**, Response to treatment of congenital adrenal hyperplasia in infancy, *Arch Dis Child* 65:441, 1990.
  256. **Quintos JB, Vogiatzi MG, Harbison MD, New MI**, Growth hormone therapy alone or in combination with gonadotropin-releasing hormone analog therapy to improve the height deficit in children with congenital adrenal hyperplasia, *J Clin Endocrinol Metab* 86:1511, 2001.
  257. **Lin-Su K, Vogiatzi MG, Marshall I, Harbison MD, Macapagal MC, Betensky B, Tansil S, New MI**, Treatment with growth hormone and luteinizing hormone releasing hormone analog improves final adult height in children with congenital adrenal hyperplasia, *J Clin Endocrinol Metab* 90:3318, 2005.
  258. **Völkl TM, Simm D, Beier C, Dorr HG**, Obesity among children and adolescents with classic congenital adrenal hyperplasia due to 21-hydroxylase deficiency, *Pediatrics* 117:e98, 2006.
  259. **Roche EF, Charmandari E, Dattani MT, Hindmarsh PC**, Blood pressure in children and adolescents with congenital adrenal hyperplasia (21-hydroxylase deficiency): a preliminary report, *Clin Endocrinol (Oxf)* 58:589, 2003.
  260. **Bruining H, Bootsma AH, Koper JW, Bonjer J, de Jong FF, Lamberts SW**, Fertility and body composition after laparoscopic bilateral adrenalectomy in a 30-year-old female with congenital adrenal hyperplasia, *J Clin Endocrinol Metab* 86:482, 2001.
  261. **Gmyrek GA, New MI, Sosa RE, Poppas DP**, Bilateral laparoscopic adrenalectomy as a treatment for classic congenital adrenal hyperplasia attributable to 21-hydroxylase deficiency, *Pediatrics* 109:E28, 2002.
  262. **Van Wyk JJ, Ritzen EM**, The role of bilateral adrenalectomy in the treatment of congenital adrenal hyperplasia, *J Clin Endocrinol Metab* 88:2993, 2003.
  263. **Ogilvie CM, Crouch NS, Rumsby G, Creighton SM, Liao LM, Conway GS**, Congenital adrenal hyperplasia in adults: a review of medical, surgical and psychological issues, *Clin Endocrinol (Oxf)* 64:2, 2006.
  264. **Nimkarn S, Lin-Su K, Berglind N, Wilson RC, New MI**, Aldosterone-to-renin ratio as a marker for disease severity in 21-hydroxylase deficiency congenital adrenal hyperplasia, *J Clin Endocrinol Metab* 92:137, 2007.
  265. **Frisch H, Battelino T, Schober E, Baumgartner-Parzer S, Nowotny P, Vierhapper H**, Salt wasting in simple virilizing congenital adrenal hyperplasia, *J Pediatr Endocrinol Metab* 14:1649, 2001.
  266. **Premawardhana LD, Hughes IA, Read GF, Scanlon MF**, Longer term outcome in females with congenital adrenal hyperplasia (CAH): the Cardiff experience, *Clin Endocrinol (Oxf)* 46:327, 1997.
  267. **Slijper FM, Drop SL, Molenaar JC, de Muinck Keizer-Schrama SM**, Long-term psychological evaluation

of intersex children, *Arch Sex Behav* 27:125, 1998.

268. **Morgan JF, Murphy H, Lacey JH, Conway G**, Long term psychological outcome for women with congenital adrenal hyperplasia: cross sectional survey, *BMJ* 330:340, 2005.
269. **Krone N, Wachter I, Stefanidou M, Roscher AA, Schwarz HP**, Mothers with congenital adrenal hyperplasia and their children: outcome of pregnancy, birth and childhood, *Clin Endocrinol (Oxf)* 55:523, 2001.
270. **Morishima A, Grumbach MM, Simpson ER, Fisher C, Qin K**, Aromatase deficiency in male and female siblings caused by a novel mutation and the physiological role of estrogens, *J Clin Endocrinol Metab* 80:3689, 1995.
271. **Mullis PE, Yoshimura N, Kuhlmann B, Lippuner K, Jaeger P, Harada H**, Aromatase deficiency in a female who is compound heterozygote for two new point mutations in the P450arom gene: impact of estrogens on hypergonadotropic hypogonadism, multicystic ovaries, and bone densitometry in childhood, *J Clin Endocrinol Metab* 82:1739, 1997.
272. **Conte FA, Grumbach MM, Ito Y, Fisher CR, Simpson ER**, A syndrome of female pseudohermaphroditism, hypergonadotropic hypogonadism, and multicystic ovaries associated with missense mutations in the gene encoding aromatase (P450arom), *J Clin Endocrinol Metab* 78:1287, 1994.
273. **Meinhardt U, Mullis PE**, The essential role of the aromatase/p450arom, *Semin Reprod Med* 20:277, 2002.
274. **Lin L, Ercan O, Raza J, Burren CP, Creighton SM, Auchus RJ, Dattani MT, Achermann JC**, Variable phenotypes associated with aromatase (CYP19) insufficiency in humans, *J Clin Endocrinol Metab* 92:982, 2007.
275. **Scott RR, Miller WL**, Genetic and clinical features of p450 oxidoreductase deficiency, *Horm Res* 69:266, 2008.
276. **Fluck CE, Tajima T, Pandey AV, Arlt W, Okuhara K, Verge CF, Jabs EW, Mendonca BB, Fujieda K, Miller WL**, Mutant P450 oxidoreductase causes disordered steroidogenesis with and without Antley-Bixler syndrome, *Nat Genet* 36:228, 2004.
277. **Burkhard FZ, Parween S, Udhane SS, Fluck CE, Pandey AV**, P450 Oxidoreductase deficiency: analysis of mutations and polymorphisms, *J Steroid Biochem Mol Biol* 165(Pt A):38, 2017.
278. **Arlt W, Walker EA, Draper N, Ivison HE, Ride JP, Hammer F, Chalder SM, Borucka-Mankiewicz M, Hauffa BP, Malunowicz EM, Stewart PM, Shackleton CH**, Congenital adrenal hyperplasia caused by mutant P450 oxidoreductase and human androgen synthesis: analytical study, *Lancet* 363:2128, 2004.
279. **Shackleton C, Marcos J, Arlt W, Hauffa BP**, Prenatal diagnosis of P450 oxidoreductase deficiency (ORD): a disorder causing low pregnancy estriol, maternal and fetal virilization, and the Antley-Bixler syndrome phenotype, *Am J Med Genet A* 129A:105, 2004.
280. **Auchus RJ**, The backdoor pathway to dihydrotestosterone, *Trends Endocrinol Metab* 15:432, 2004.
281. **Homma K, Hasegawa T, Nagai T, Adachi M, Horikawa R, Fujiwara I, Tajima T, Takeda R, Fukami M, Ogata T**, Urine steroid hormone profile analysis in cytochrome P450 oxidoreductase deficiency: implication for the backdoor pathway to dihydrotestosterone, *J Clin Endocrinol Metab* 91:2643, 2006.
282. **Fukami M, Hasegawa T, Horikawa R, Ohashi T, Nishimura G, Homma K, Ogata T**, Cytochrome P450 oxidoreductase deficiency in three patients initially regarded as having 21-hydroxylase deficiency and/or aromatase deficiency: diagnostic value of urine steroid hormone analysis, *Pediatr Res* 59:276, 2006.
283. **Duck SC, Katayama KP**, Danazol may cause female pseudohermaphroditism, *Fertil Steril* 35:230, 1981.
284. **Wilkins L, Jones HW Jr, Holman GH, Stempfel RS Jr**, Masculinization of the female fetus associated with administration of oral and intramuscular progestins during gestation: non-adrenal female pseudohermaphroditism, *J Clin Endocrinol Metab* 18:559, 1958.
285. **Grumbach MM, Ducharme JR, Moloshok RE**, On the fetal masculinizing action of certain oral progestins, *J Clin Endocrinol Metab* 19:1369, 1959.
286. **Practice Committee of the American Society for Reproductive Medicine**, Progesterone supplementation during the luteal phase and in early pregnancy in the treatment of infertility: an educational bulletin, *Fertil Steril* 90:S150, 2008.
287. **Bracken MB**, Oral contraception and congenital malformations in offspring: a review and meta-analysis of the prospective studies, *Obstet Gynecol* 76:552, 1990.

288. **McClamrock HD, Adashi EY**, Gestational hyperandrogenism, *Fertil Steril* 57:257, 1992.
289. **Verhoeven AT, Mastboom JL, van Leusden HA, van der Velden WH**, Virilization in pregnancy coexisting with an (ovarian) mucinous cystadenoma: A case report and review of virilizing ovarian tumors in pregnancy, *Obstet Gynecol Surv* 28:597, 1973.
290. **Novak DJ, Lauchlan SC, McCawley JC, Maccawley JC, Faiman C**, Virilization during pregnancy. Case report and review of literature, *Am J Med* 49:281, 1970.
291. **Silva PD, Porto M, Moyer DL, Lobo RA**, Clinical and ultrastructural findings of an androgenizing Krukenberg tumor in pregnancy, *Obstet Gynecol* 71:432, 1988.
292. **Fayez JA, Bunch TR, Miller GL**, Virilization in pregnancy associated with an ovarian cystadenoma, *Am J Obstet Gynecol* 120:341, 1974.
293. **Duska LR, Flynn C, Goodman A**, Masculinizing sclerosing stromal cell tumor in pregnancy: report of a case and review of the literature, *Eur J Gynaecol Oncol* 19:441, 1998.
294. **Kirk JM, Perry LA, Shand WS, Kirby RS, Besser GM, Savage MO**, Female pseudohermaphroditism due to a maternal adrenocortical tumor, *J Clin Endocrinol Metab* 70:1280, 1990.
295. **Galle PC, McCool JA, Elsner CW**, Arrhenoblastoma during pregnancy, *Obstet Gynecol* 51:359, 1978.
296. **Montz FJ, Schlaerth JB, Morrow CP**, The natural history of theca lutein cysts, *Obstet Gynecol* 72:247, 1988.
297. **Garcia-Bunuel R, Berek JS, Woodruff JD**, Luteomas of pregnancy, *Obstet Gynecol* 45:407, 1975.
298. **Shortle BE, Warren MP, Tsin D**, Recurrent androgenicity in pregnancy: a case report and literature review, *Obstet Gynecol* 70:462, 1987.
299. **Spitzer RF, Wherrett D, Chitayat D, Colgan T, Dodge JE, Salle JL, Allen L**, Maternal luteoma of pregnancy presenting with virilization of the female infant, *J Obstet Gynaecol Can* 29:835, 2007.
300. **Joshi R, Dunaif A**, Ovarian disorders of pregnancy, *Endocrinol Metab Clin North Am* 24:153, 1995.
301. **Grumbach MM, Ducharme JR**, The effects of androgens on fetal sexual development: androgen-induced female pseudohermaphroditism, *Fertil Steril* 11:157, 1960.
302. **Verkauf BS, Reiter EO, Hernandez L, Burns SA**, Virilization of mother and fetus associated with luteoma of pregnancy: a case report with endocrinologic studies, *Am J Obstet Gynecol* 129:274, 1977.
303. **Nagamani M, Gomez LG, Garza J**, In vivo steroid studies in luteoma of pregnancy, *Obstet Gynecol* 59:105S, 1982.
304. **Floyd WS**, Theca-lutein cysts of the ovary in a multiple pregnancy, *Obstet Gynecol* 15:743, 1960.
305. **Caspi E, Schreyer P, Bukovsky J**, Ovarian lutein cysts in pregnancy, *Obstet Gynecol* 42:388, 1973.
306. **Klein J**, Delayed appearance and rupture of lutein cysts with hydatidiform mole. Report of a case, *Obstet Gynecol* 21:30, 1963.
307. **Magendantz HG, Jones DE, Schomberg DW**, Virilization during pregnancy associated with polycystic ovary disease, *Obstet Gynecol* 40:156, 1972.
308. **Ben-Chetrit A, Greenblatt EM**, Recurrent maternal virilization during pregnancy associated with polycystic ovarian syndrome: a case report and review of the literature, *Hum Reprod* 10:3057, 1995.
309. **Bradshaw KD, Santos-Ramos R, Rawlins SC, MacDonald PC, Parker CR Jr**, Endocrine studies in a pregnancy complicated by ovarian theca lutein cysts and hyperreactio luteinalis, *Obstet Gynecol* 67:66S, 1986.
310. **Muechler EK, Fichter J, Zongrone J**, Human chorionic gonadotropin, estriol, and testosterone changes in two pregnancies with hyperreactio luteinalis, *Am J Obstet Gynecol* 157:1126, 1987.
311. **Wajda KJ, Lucas JG, Marsh WL Jr**, Hyperreactio luteinalis. Benign disorder masquerading as an ovarian neoplasm, *Arch Pathol Lab Med* 113:921, 1989.
312. **Berger NG, Repke JT, Woodruff JD**, Markedly elevated serum testosterone in pregnancy without fetal virilization, *Obstet Gynecol* 63:260, 1984.
313. **Hensleigh PA, Carter RP, Grotjan HE Jr**, Fetal protection against masculinization with hyperreactio luteinalis and virilization, *J Clin Endocrinol Metab* 40:816, 1975.
314. **Lund DP, Hendren WH**, Cloacal exstrophy: a 25-year experience with 50 cases, *J Pediatr Surg* 36:68, 2001.
315. **Bruch SW, Adzick NS, Goldstein RB, Harrison MR**, Challenging the embryogenesis of cloacal exstrophy, *J Pediatr Surg* 31:768, 1996.

316. **Strubbe EH, Willemsen WN, Lemmens JA, Thijn CJ, Rolland R,** Mayer-Rokitansky-Küster-Hauser syndrome: distinction between two forms based on excretory urographic, sonographic, and laparoscopic findings, *Am J Roentgenol* 160:331, 1993.
317. **Behera M, Couchman G, Walmer D, Price TM,** Mullerian agenesis and thrombocytopenia absent radius syndrome: a case report and review of syndromes associated with Mullerian agenesis, *Obstet Gynecol Surv* 60:453, 2005.
318. **Fedele L, Bianchi S, Frontino G, Ciappina N, Fontana E, Borruto F,** Laparoscopic findings and pelvic anatomy in Mayer-Rokitansky-Küster-Hauser syndrome, *Obstet Gynecol* 109:1111, 2007.
319. **Zenteno JC, Carranza-Lira S, Kofman-Alfaro S,** Molecular analysis of the anti-Mullerian hormone, the anti-Mullerian hormone receptor, and galactose-1-phosphate uridyl transferase genes in patients with the Mayer-Rokitansky-Küster-Hauser syndrome, *Arch Gynecol Obstet* 269:270, 2004.
320. **Letterie GS, Wilson J, Miyazawa K,** Magnetic resonance imaging of müllerian tract abnormalities, *Fertil Steril* 50:365, 1988.
321. **Fedele L, Dorta M, Brioschi D, Giudici MN, Candiani GB,** Magnetic resonance imaging in Mayer-Rokitansky-Küster-Hauser Syndrome, *Obstet Gynecol* 76:593, 1990.
322. **Frank RT,** Formation of artificial vagina without operation, *Am J Obstet Gynecol* 35:1053, 1938.
323. **Wabrek AJ, Millard PR, Wilson WB Jr, Pion RJ,** Creation of a neovagina by the Frank nonoperative method, *Obstet Gynecol* 37:408, 1971.
324. **Costa EMF, Mendonca BB, Inácio M, Arnhold IJP, Silva FAQ, Lodovici O,** Management of ambiguous genitalia in pseudohermaphrodites: new perspectives on vaginal dilation, *Fertil Steril* 67:229, 1997.
325. **McIndoe AH, Banister JB,** An operation for the cure of congenital absence of the vagina, *J Obstet Gynaecol Br Empire* 45:490, 1938.
326. **Brucker SY, Gegusch M, Zubke W, Rall K, Gauwerky JF, Wallwiener D,** Neovagina creation in vaginal agenesis: development of a new laparoscopic Vecchiatti-based procedure and optimized instruments in a prospective comparative interventional study in 101 patients, *Fertil Steril* 90:1940, 2008.
327. **Fedele L, Bianchi S, Frontino G, Fontana E, Restelli E, Bruni V,** The laparoscopic Vecchiatti's modified technique in Rokitansky syndrome: anatomic, functional, and sexual long-term results, *Am J Obstet Gynecol* 198:377 e1, 2008.
328. **Batzer FR, Corson SL, Gocial B, Daly DC, Go K, English ME,** Genetic offspring in patients with vaginal agenesis: specific medical and legal issues, *Am J Obstet Gynecol* 167:1288, 1992.
329. **Beski S, Gorgy A, Venkat G, Craft IL, Edmonds K,** Gestational surrogacy: a feasible option for patients with Rokitansky syndrome, *Hum Reprod* 15:2326, 2000.
330. **Brännström M, Johannesson L, Bokström H, Kvarnström N, Mölne J, Dahm-Kähler P, Enskog A, Milenkovic M, Ekberg J, Diaz-Garcia C, Gäbel M, Hanafy A, Hagberg H, Olausson M, Nilsson L,** Livebirth after uterus transplantation, *Lancet* 385:607, 2015.
331. **Brännström M,** Current status and future direction of uterus transplantation, *Curr Opin Organ Transplant* 23:5, 2018.
332. **Uliana V, Giordano N, Caselli R, Papa FT, Ariani F, Marcocci C, Gianetti E, Martini G, Papakostas P, Rollo F, Meloni I, Mari F, Priolo M, Renieri A, Nuti R,** Expanding the phenotype of 22q11 deletion syndrome: the MURCS association, *Clin Dysmorphol* 17:13, 2008.
333. **Duncan PA, Shapiro LR, Stangel JJ, Klein RM, Addonizio JC,** The MURCS association: Mullerian duct aplasia, renal aplasia, and cervicothoracic somite dysplasia, *J Pediatr* 95:399, 1979.
334. **Greene RA, Bloch MJ, Huff DS, Iozzo RV,** MURCS association with additional congenital anomalies, *Hum Pathol* 17:88, 1986.
335. **Lin HJ, Cornford ME, Hu B, Rutgers JK, Beall MH, Lachman RS,** Occipital encephalocele and MURCS association: case report and review of central nervous system anomalies in MURCS patients, *Am J Med Genet* 61:59, 1996.
336. **Gunsar C, Genc A, Sencan A, Daglar Z, Alparslan O, Mir E,** MURCS association and rectovestibular fistula: case report of a patient treated with one-stage posterior sagittal anorectoplasty and sigmoid loop vaginoplasty, *J Pediatr Surg* 38:262, 2003.



337. **Ledig S, Wieacker P**, Clinical and genetic aspects of Mayer-Rokitansky-Küster-Hauser syndrome, *Med Genet* 30:1 2018.
338. **Swyer GI**, Male pseudohermaphroditism: a hitherto undescribed form, *Br Med J* 2:709, 1955.
339. **Berkovitz GD, Fechner PY, Zacur HW, Rock JA, Snyder HM, Migeon CJ, Perlman EJ**, Clinical and pathologic spectrum of 46,XY gonadal dysgenesis: its relevance to the understanding of sex differentiation, *Medicine* 70:375, 1991.
340. **Sanchez-Moreno I, Canto P, Munguia P, de Leon MB, Cisneros B, Vilchis F, Reyes E, Mendez JP**, DNA binding activity studies and computational approach of mutant SRY in patients with 46, XY complete pure gonadal dysgenesis, *Mol Cell Endocrinol* 299:212, 2009.
341. **Assumpcao JG, Benedetti CE, Maciel-Guerra AT, Guerra G Jr, Baptista MT, Scolfaro MR, de Mello MP**, Novel mutations affecting SRY DNA-binding activity: the HMG box N65H associated with 46,XY pure gonadal dysgenesis and the familial non-HMG box R30I associated with variable phenotypes, *J Mol Med* 80:782, 2002.
342. **Canto P, Soderlund D, Reyes E, Mendez JP**, Mutations in the desert hedgehog (DHH) gene in patients with 46,XY complete pure gonadal dysgenesis, *J Clin Endocrinol Metab* 89:4480, 2004.
343. **Paris F, Philibert P, Lumbroso S, Baldet P, Charvet JP, Galifer RB, Sultan C**, Primary amenorrhea in a 46,XY adolescent girl with partial gonadal dysgenesis: identification of a new SRY gene mutation, *Fertil Steril* 88:1437.e21, 2007.
344. **Cools M, Stoop H, Kersemaekers AM, Drop SL, Wolffenbuttel KP, Bourguignon JP, Slowikowska-Hilczer J, Kula K, Faradz SM, Oosterhuis JW, Looijenga LH**, Gonadoblastoma arising in undifferentiated gonadal tissue within dysgenetic gonads, *J Clin Endocrinol Metab* 91:2404, 2006.
345. **Plante BJ, Fritz MA**, A case report of successful pregnancy in a patient with pure 46,XY gonadal dysgenesis, *Fertil Steril* 90:2015.e1, 2008.
346. **Chauhan V, Jyotsna VP, Jain V, Khadgawat R, Dada R**, Novel heterozygous genetic variants in patients with 46, XY gonadal dysgenesis, *Horm Metab Res* 49:1, 2017.
347. **Bastian C, Muller JB, Lortat-Jacob S, Nihoul-Fekete C, Bignon-Topalovic J, McElreavey K, Bashamboo A, Brauner R**, Genetic mutations and somatic anomalies in association with 46, XY gonadal dysgenesis, *Fertil Steril* 103:5, 2015.
348. **Hegarty PK, Mushtaq I, Sebire NJ**, Natural history of testicular regression syndrome and consequences for clinical management, *J Pediatr Urol* 3:206, 2007.
349. **Rattanachaiyanont M, Phoppong P, Techatraisak K, Charoenpanich P, Jitraphai P**, Embryonic testicular regression syndrome: a case report, *J Med Assoc Thai* 82:506, 1999.
350. **Smith NM, Byard RW, Bourne AJ**, Testicular regression syndrome—a pathological study of 77 cases, *Histopathology* 19:269, 1991.
351. **Grady RW, Mitchell ME, Carr MC**, Laparoscopic and histologic evaluation of the inguinal vanishing testis, *Urology* 52:866, 1998.
352. **Walsh PC, Madden JD, Harrod MJ, Goldstein JL, MacDonald PC, Wilson JD**, Familial incomplete male pseudohermaphroditism, type 2. Decreased dihydrotestosterone formation in pseudovaginal perineoscrotal hypospadias, *N Engl J Med* 291:944, 1974.
353. **Imperato-McGinley J, Guerrero L, Gautier T, Peterson RE**, Steroid 5 $\alpha$ -reductase deficiency in man: an inherited form of male pseudohermaphroditism, *Science* 186:1213, 1974.
354. **Peterson RE, Imperato-McGinley J, Gautier T, Sturla E**, Male pseudohermaphroditism due to steroid 5 $\alpha$ -reductase deficiency, *Am J Med* 62:170, 1977.
355. **Wilson JD, Griffin JE, Russell DW**, Steroid 5  $\alpha$ -reductase 2 deficiency, *Endocr Rev* 14:577, 1993.
356. **Imperato-McGinley J, Peterson RE, Gautier T, Sturla E**, Androgens and the evolution of male gender identity among male pseudohermaphrodites with 5 $\alpha$ -reductase deficiency, *N Engl J Med* 300:1233, 1979.
357. **Fratianni CM, Imperato-McGinley J**, The syndrome of 5 $\alpha$ -reductase-2 deficiency, *Endocrinologist* 4:301, 1994.
358. **Wilson JD, George FW, Griffin JE**, The hormonal control of sexual development, *Science* 211:1278, 1981.
359. **Andersson S, Russell DW**, Structural and biochemical properties of cloned and expressed human and rat

- steroid 5 alpha-reductases, *Proc Natl Acad Sci U S A* 87:3640, 1990.
360. Griffin JE, McPhaul MJ, Russell DW, Wilson JD, The androgen resistance syndromes: steroid 5-alpha-reductase 2 deficiency, testicular feminization, and related disorders, In: Scriver CR, et al., eds. *The Metabolic and Molecular Basis of Inherited Disease*, McGraw-Hill, New York, 2001, p. 4117.
  361. **Mazen I, Gad YZ, Hafez M, Sultan C, Lumbroso S**, Molecular analysis of 5alpha-reductase type 2 gene in eight unrelated egyptian children with suspected 5alpha-reductase deficiency: prevalence of the G34R mutation, *Clin Endocrinol (Oxf)* 58:627, 2003.
  362. **Katz MD, Cai L-Q, Zhu Y-S, Herrera C, DeFillo-Ricart M, Shackleton CHL, Imperato-McGinley J**, The biochemical and phenotypic characterization of females homozygous for 5 $\alpha$ -reductase-2 deficiency, *J Clin Endocrinol Metab* 80:3160, 1995.
  363. **Milewich L, Mendonca BB, Arnhold I, Wallace AM, Donaldson MD, Wilson JD, Russell DW**, Women with steroid 5 alpha-reductase 2 deficiency have normal concentrations of plasma 5 alpha-dihydroprogesterone during the luteal phase, *J Clin Endocrinol Metab* 80:3136, 1995.
  364. **Mendonca BB, Inacio M, Costa EM, Arnhold IJ, Silva FA, Nicolau W, Bloise W, Russel DW, Wilson JD**, Male pseudohermaphroditism due to steroid 5alpha-reductase 2 deficiency. Diagnosis, psychological evaluation, and management, *Medicine (Baltimore)* 75:64, 1996.
  365. **Imperato-McGinley J, Gautier T, Pichardo M, Shackleton C**, The diagnosis of 5 alpha-reductase deficiency in infancy, *J Clin Endocrinol Metab* 63:1313, 1986.
  366. **Forest MG**, Pattern of the response of testosterone and its precursors to human chorionic gonadotropin stimulation in relation to age in infants and children, *J Clin Endocrinol Metab* 49:132, 1979.
  367. **Imperato-McGinley J, Peterson RE, Gautier T, Cooper G, Danner R, Arthur A, Morris PL, Sweeney WJ, Shackleton C**, Hormonal evaluation of a large kindred with complete androgen insensitivity: evidence for secondary 5 alpha-reductase deficiency, *J Clin Endocrinol Metab* 54:931, 1982.
  368. **Sasaki G, Nakagawa K, Hashiguchi A, Hasegawa T, Ogata T, Murai M**, Giant seminoma in a patient with 5 alpha-reductase type 2 deficiency, *J Urol* 169:1080, 2003.
  369. **Ingram J**, The bicycle seat stool in the treatment of vaginal agenesis and stenosis: a preliminary report, *Am J Obstet Gynecol* 140:867, 1981.
  370. **Purves JT, Miles-Thomas J, Migeon C, Gearhart JP**, Complete androgen insensitivity: the role of the surgeon, *J Urol* 180:1716, 2008.
  371. **Price P, Wass JA, Griffin JE, Leshin M, Savage MO, Large DM, Bu'Lock DE, Anderson DC, Wilson JD, Besser GM**, High dose androgen therapy in male pseudohermaphroditism due to 5 alpha-reductase deficiency and disorders of the androgen receptor, *J Clin Invest* 74:1496, 1984.
  372. **Keenan BS, Eberle AJ, Sparrow JT, Greger NG, Panko WB**, Dihydrotestosterone heptanoate: synthesis, pharmacokinetics, and effects on hypothalamic-pituitary-testicular function, *J Clin Endocrinol Metab* 64:557, 1987.
  373. **Carpenter TO, Imperato-McGinley J, Boulware SD, Weiss RM, Shackleton C, Griffin JE, Wilson JD**, Variable expression of 5 alpha-reductase deficiency: presentation with male phenotype in a child of Greek origin, *J Clin Endocrinol Metab* 71:318, 1990.
  374. **Cai LQ, Fratianni CM, Gautier T, Imperato-McGinley J**, Dihydrotestosterone regulation of semen in male pseudohermaphrodites with 5 alpha-reductase-2 deficiency, *J Clin Endocrinol Metab* 79:409, 1994.
  375. **Katz MD, Kligman I, Cai LQ, Zhu YS, Fratianni CM, Zervoudakis I, Rosenwaks Z, Imperato-McGinley J**, Paternity by intrauterine insemination with sperm from a man with 5alpha-reductase-2 deficiency, *N Engl J Med* 336:994, 1997.
  376. **Bourne H, Richings N, Harari O, Watkins W, Speirs AL, Johnston WI, Baker HW**, The use of intracytoplasmic sperm injection for the treatment of severe and extreme male infertility, *Reprod Fertil Dev* 7:237, 1995.
  377. **Eugenides J**, Middlesex, Farrar Straus & Giroux, New York, 2002.
  378. **Yanase T, Simpson ER, Waterman MR**, 17 alpha-hydroxylase/17,20-lyase deficiency: from clinical investigation to molecular definition, *Endocr Rev* 12:91, 1991.
  379. **Biglieri EG**, 17 alpha-Hydroxylase deficiency: 1963–1966, *J Clin Endocrinol Metab* 82:48, 1997.

380. **Zachmann M, Vollmin JA, Hamilton W, Prader A**, Steroid 17,20-desmolase deficiency: a new cause of male pseudohermaphroditism, *Clin Endocrinol (Oxf)* 1:369, 1972.
381. **Zachmann M, Werder EA, Prader A**, Two types of male pseudohermaphroditism due to 17, 20-desmolase deficiency, *J Clin Endocrinol Metab* 55:487, 1982.
382. **Winter JS, Couch RM, Muller J, Perry YS, Ferreira P, Baydala L, Shackleton CH**, Combined 17-hydroxylase and 17,20-desmolase deficiencies: evidence for synthesis of a defective cytochrome P450c17, *J Clin Endocrinol Metab* 68:309, 1989.
383. **Kater CE, Biglieri EG, Brust N, Chang B, Hirai J**, The unique patterns of plasma aldosterone and 18-hydroxycorticosterone concentrations in the 17 alpha-hydroxylase deficiency syndrome, *J Clin Endocrinol Metab* 55: 295, 1982.
384. **Griffing GT, Wilson TE, Holbrook MM, Dale SL, Jackson TK, Ullrich I, Melby JC**, Plasma and urinary 19-nor-deoxycorticosterone in 17 alpha-hydroxylase deficiency syndrome, *J Clin Endocrinol Metab* 59:1011, 1984.
385. **Rovner DR, Conn JW, Cohen EL, Berlinger FG, Kem DC, Gordon DL**, 17 alpha-Hydroxylase deficiency. A combination of hydroxylation defect and reversible blockade in aldosterone biosynthesis, *Acta Endocrinol (Copenh)* 90:490, 1979.
386. **Costa-Santos M, Kater CE, Auchus RJ**, Two prevalent CYP17 mutations and genotype-phenotype correlations in 24 Brazilian patients with 17-hydroxylase deficiency, *J Clin Endocrinol Metab* 89:49, 2004.
387. **Yanase T, Sanders D, Shibata A, Matsui N, Simpson ER, Waterman MR**, Combined 17 alpha-hydroxylase/17,20-lyase deficiency due to a 7-basepair duplication in the N-terminal region of the cytochrome P45017 alpha (CYP17) gene, *J Clin Endocrinol Metab* 70:1325, 1990.
388. **Yanase T, Kagimoto M, Suzuki S, Hashiba K, Simpson ER, Waterman MR**, Deletion of a phenylalanine in the N-terminal region of human cytochrome P-450(17 alpha) results in partial combined 17 alpha-hydroxylase/17,20-lyase deficiency, *J Biol Chem* 264:18076, 1989.
389. **Fardella CE, Hum DW, Homoki J, Miller WL**, Point mutation of Arg440 to His in cytochrome P450c17 causes severe 17 alpha-hydroxylase deficiency, *J Clin Endocrinol Metab* 79:160, 1994.
390. **Biason A, Mantero F, Scaroni C, Simpson ER, Waterman MR**, Deletion within the CYP17 gene together with insertion of foreign DNA is the cause of combined complete 17 alpha-hydroxylase/17,20-lyase deficiency in an Italian patient, *Mol Endocrinol* 5:2037, 1991.
391. **Yanase T, Kagimoto M, Matsui N, Simpson ER, Waterman MR**, Combined 17 alpha-hydroxylase/17,20-lyase deficiency due to a stop codon in the N-terminal region of 17 alpha-hydroxylase cytochrome P-450, *Mol Cell Endocrinol* 59:249, 1988.
392. **Rumsby G, Skinner C, Lee HA, Honour JW**, Combined 17 alpha-hydroxylase/17,20-lyase deficiency caused by heterozygous stop codons in the cytochrome P450 17 alpha-hydroxylase gene, *Clin Endocrinol (Oxf)* 39:483, 1993.
393. **Monno S, Ogawa H, Date T, Fujioka M, Miller WL, Kobayashi M**, Mutation of histidine 373 to leucine in cytochrome P450c17 causes 17 alpha-hydroxylase deficiency, *J Biol Chem* 268:25811, 1993.
394. **Lin D, Harikrishna JA, Moore CC, Jones KL, Miller WL**, Missense mutation serine106—proline causes 17 alpha-hydroxylase deficiency, *J Biol Chem* 266:15992, 1991.
395. **Yanase T, Waterman MR, Zachmann M, Winter JS, Simpson ER, Kagimoto M**, Molecular basis of apparent isolated 17,20-lyase deficiency: compound heterozygous mutations in the C-terminal region (Arg(496)—Cys, Gln(461)—Stop) actually cause combined 17 alpha-hydroxylase/17,20-lyase deficiency, *Biochim Biophys Acta* 1139:275, 1992.
396. **Ahlgren R, Yanase T, Simpson ER, Winter JS, Waterman MR**, Compound heterozygous mutations (Arg 239—stop, Pro 342—Thr) in the CYP17 (P45017 alpha) gene lead to ambiguous external genitalia in a male patient with partial combined 17 alpha-hydroxylase/17,20-lyase deficiency, *J Clin Endocrinol Metab* 74:667, 1992.
397. **Yamaguchi H, Nakazato M, Miyazato M, Kangawa K, Matsukura S**, A 5'-splice site mutation in the cytochrome P450 steroid 17alpha-hydroxylase gene in 17alpha-hydroxylase deficiency, *J Clin Endocrinol Metab* 82:1934, 1997.

398. **Brooke AM, Taylor NF, Shepherd JH, Gore ME, Ahmad T, Lin L, Rumsby G, Papari-Zareei M, Auchus RJ, Achermann JC, Monson JP**, A novel point mutation in P450c17 (CYP17) causing combined 17 $\alpha$ -hydroxylase/17,20-lyase deficiency, *J Clin Endocrinol Metab* 91:2428, 2006.
399. **Biglieri EG, Herron MA, Brust N**, 17-Hydroxylation deficiency in man, *J Clin Invest* 45:1946, 1966.
400. **Goldsmith O, Solomon DH, Horton R**, Hypogonadism and mineralocorticoid excess. The 17-hydroxylase deficiency syndrome, *N Engl J Med* 277:673, 1967.
401. **New MI**, Male pseudohermaphroditism due to 17  $\alpha$ -hydroxylase deficiency, *J Clin Invest* 49:1930, 1970.
402. **Morel Y, Mebarki F, Rheume E, Sanchez R, Forest MG, Simard J**, Structure-function relationships of 3  $\beta$ -hydroxysteroid dehydrogenase: contribution made by the molecular genetics of 3  $\beta$ -hydroxysteroid dehydrogenase deficiency, *Steroids* 62:176, 1997.
403. **Pang S**, The Molecular and Clinical Spectrum of 3 $\beta$ -hydroxysteroid Dehydrogenase Deficiency Disorder, *Trends Endocrinol Metab* 9:82, 1998.
404. **Andersson S, Russell DW, Wilson JD**, 17 $\beta$ -Hydroxysteroid dehydrogenase 3 deficiency, *Trends Endocrinol Metab* 7:121, 1996.
405. **Faienza MF, Giordani L, Delvecchio M, Cavallo L**, Clinical, endocrine, and molecular findings in 17 $\beta$ -hydroxysteroid dehydrogenase type 3 deficiency, *J Endocrinol Invest* 31:85, 2008.
406. **Boehmer AL, Brinkmann AO, Sandkuijl LA, Halley DJ, Niermeijer MF, Andersson S, de Jong FH, Kayserili H, de Vroede MA, Otten BJ, Rouwe CW, Mendonca BB, Rodrigues C, Bode HH, de Ruiter PE, Delemarre-van de Waal HA, Drop SL**, 17 $\beta$ -hydroxysteroid dehydrogenase-3 deficiency: diagnosis, phenotypic variability, population genetics, and worldwide distribution of ancient and de novo mutations, *J Clin Endocrinol Metab* 84:4713, 1999.
407. **Ulloa-Aguirre A, Bassol S, Poo J, Mendez JP, Mutchinick O, Robles C, Perez-Palacios G**, Endocrine and biochemical studies in a 46,XY phenotypically male infant with 17-ketosteroid reductase deficiency, *J Clin Endocrinol Metab* 60:639, 1985.
408. **Goebelsmann U, Horton R, Mestman JH, Arce JJ, Nagata Y, Nakamura RM, Thorneycroft IH, Mishell DR Jr**, Male pseudohermaphroditism due to testicular 17 -hydroxysteroid dehydrogenase deficiency, *J Clin Endocrinol Metab* 36:867, 1973.
409. **Martel C, Rheume E, Takahashi M, Trudel C, Couet J, Luu-The V, Simard J, Labrie F**, Distribution of 17  $\beta$ -hydroxysteroid dehydrogenase gene expression and activity in rat and human tissues, *J Steroid Biochem Mol Biol* 41:597, 1992.
410. **Hoppe U, Holterhus PM, Wunsch L, Jocham D, Drechsler T, Thiele S, Marschke C, Hiort O**, Tissue-specific transcription profiles of sex steroid biosynthesis enzymes and the androgen receptor, *J Mol Med* 84:651, 2006.
411. **Wilson JD**, The role of androgens in male gender role behavior, *Endocr Rev* 20:726, 1999.
412. **Gross DJ, Landau H, Kohn G, Farkas A, Elrayyes E, el-Shawwa R, Lasch EE, Rosler A**, Male pseudohermaphroditism due to 17  $\beta$ -hydroxysteroid dehydrogenase deficiency: gender reassignment in early infancy, *Acta Endocrinol (Copenh)* 112:238, 1986.
413. **Farkas A, Rosler A**, Ten years experience with masculinizing genitoplasty in male pseudohermaphroditism due to 17  $\beta$ -hydroxysteroid dehydrogenase deficiency, *Eur J Pediatr* 152(Suppl 2):S88, 1993.
414. **Lin D, Sugawara T, Strauss JF III, Clark BJ, Stocco DM, Saenger P, Rogol A, Miller WL**, Role of steroidogenic acute regulatory protein in adrenal and gonadal steroidogenesis, *Science* 267:1828, 1995.
415. **Sugawara T, Holt JA, Driscoll D, Strauss JF III, Lin D, Miller WL, Patterson D, Clancy KP, Hart IM, Clark BJ**, et al., Human steroidogenic acute regulatory protein: functional activity in COS-1 cells, tissue-specific expression, and mapping of the structural gene to 8p11.2 and a pseudogene to chromosome 13, *Proc Natl Acad Sci U S A* 92:4778, 1995.
416. **Clark BJ, Wells J, King SR, Stocco DM**, The purification, cloning, and expression of a novel luteinizing hormone-induced mitochondrial protein in MA-10 mouse Leydig tumor cells. Characterization of the steroidogenic acute regulatory protein (StAR), *J Biol Chem* 269:28314, 1994.
417. **Bose HS, Sugawara T, Strauss JF III, Miller WL**, The pathophysiology and genetics of congenital lipoid adrenal hyperplasia. International Congenital Lipoid Adrenal Hyperplasia Consortium, *N Engl J Med* 335:1870,

1996.

418. **Katsumata N, Ohtake M, Hojo T, Ogawa E, Hara T, Sato N, Tanaka T**, Compound heterozygous mutations in the cholesterol side-chain cleavage enzyme gene (CYP11A) cause congenital adrenal insufficiency in humans, *J Clin Endocrinol Metab* 87:3808, 2002.
419. **Fujieda K, Okuhara K, Abe S, Tajima T, Mukai T, Nakae J**, Molecular pathogenesis of lipoid adrenal hyperplasia and adrenal hypoplasia congenita, *J Steroid Biochem Mol Biol* 85:483, 2003.
420. **Tajima T, Fujieda K, Kouda N, Nakae J, Miller WL**, Heterozygous mutation in the cholesterol side chain cleavage enzyme (p450scc) gene in a patient with 46,XY sex reversal and adrenal insufficiency, *J Clin Endocrinol Metab* 86:3820, 2001.
421. **Hauffa BP, Miller WL, Grumbach MM, Conte FA, Kaplan SL**, Congenital adrenal hyperplasia due to deficient cholesterol side-chain cleavage activity (20, 22-desmolase) in a patient treated for 18 years, *Clin Endocrinol (Oxf)* 23:481, 1985.
422. **Gassner HL, Toppari J, Quinteiro Gonzalez S, Miller WL**, Near-miss apparent SIDS from adrenal crisis, *J Pediatr* 145:178, 2004.
423. **Fujieda K, Tajima T, Nakae J, Sageshima S, Tachibana K, Suwa S, Sugawara T, Strauss JF III**, Spontaneous puberty in 46,XX subjects with congenital lipoid adrenal hyperplasia. Ovarian steroidogenesis is spared to some extent despite inactivating mutations in the steroidogenic acute regulatory protein (StAR) gene, *J Clin Invest* 99:1265, 1997.
424. **Bose HS, Pescovitz OH, Miller WL**, Spontaneous feminization in a 46,XX female patient with congenital lipoid adrenal hyperplasia due to a homozygous frameshift mutation in the steroidogenic acute regulatory protein, *J Clin Endocrinol Metab* 82:1511, 1997.
425. **Galani A, Kitsiou-Tzeli S, Sofokleous C, Kanavakis E, Kalpini-Mavrou A**, Androgen insensitivity syndrome: clinical features and molecular defects, *Hormones (Athens)* 7:217, 2008.
426. **Griffin JE, Punyashthiti K, Wilson JD**, Dihydrotestosterone binding by cultured human fibroblasts. Comparison of cells from control subjects and from patients with hereditary male pseudohermaphroditism due to androgen resistance, *J Clin Invest* 57:1342, 1976.
427. **Kaufman M, Straisfeld C, Pinsky L**, Male pseudohermaphroditism presumably due to target organ unresponsiveness to androgens. Deficient 5alpha-dihydrotestosterone binding in cultured skin fibroblasts, *J Clin Invest* 58:345, 1976.
428. **Griffin JE**, Testicular feminization associated with a thermolabile androgen receptor in cultured human fibroblasts, *J Clin Invest* 64:1624, 1979.
429. **Brown TR, Maes M, Rothwell SW, Migeon CJ**, Human complete androgen insensitivity with normal dihydrotestosterone receptor binding capacity in cultured genital skin fibroblasts: evidence for a qualitative abnormality of the receptor, *J Clin Endocrinol Metab* 55:61, 1982.
430. **Pinsky L, Kaufman M, Killinger DW, Burko B, Shatz D, Volpe R**, Human minimal androgen insensitivity with normal dihydrotestosterone-binding capacity in cultured genital skin fibroblasts: evidence for an androgen-selective qualitative abnormality of the receptor, *Am J Hum Genet* 36:965, 1984.
431. **Griffin JE**, Androgen resistance — the clinical and molecular spectrum, *N Engl J Med* 326:611, 1992.
432. **Morris JM, Mahesh BV**, The syndrome of testicular feminization in male pseudohermaphrodites, *Am J Obstet Gynecol* 65:1192, 1953.
433. **Keenan BS, Meyer WJ III, Hadjian AJ, Jones HW, Migeon CJ**, Syndrome of androgen insensitivity in man: absence of 5 alpha-dihydrotestosterone binding protein in skin fibroblasts, *J Clin Endocrinol Metab* 38:1143, 1974.
434. **Hiort O, Sinnecker GH, Holterhus PM, Nitsche EM, Kruse K**, Inherited and de novo androgen receptor gene mutations: investigation of single-case families, *J Pediatr* 132:939, 1998.
435. **Hannema SE, Scott IS, Hodapp J, Martin H, Coleman N, Schwabe JW, Hughes IA**, Residual activity of mutant androgen receptors explains wolffian duct development in the complete androgen insensitivity syndrome, *J Clin Endocrinol Metab* 89:5815, 2004.
436. **Dodge ST, Finkelston MS, Miyazawa K**, Testicular feminization with incomplete Mullerian regression, *Fertil Steril* 43:937, 1985.

437. **Varrela J, Alvesalo L, Vinkka H**, Body size and shape in 46,XY females with complete testicular feminization, *Ann Hum Biol* 11:291, 1984.
438. **Danilovic DL, Correa PH, Costa EM, Melo KF, Mendonca BB, Arnhold IJ**, Height and bone mineral density in androgen insensitivity syndrome with mutations in the androgen receptor gene, *Osteoporos Int* 18:369, 2007.
439. **Money J, Ehrhardt AA, Masica DN**, Fetal feminization induced by androgen insensitivity in the testicular feminizing syndrome: effect on marriage and maternalism, *Johns Hopkins Med J* 123:105, 1968.
440. **Hines M, Ahmed SF, Hughes IA**, Psychological outcomes and gender-related development in complete androgen insensitivity syndrome, *Arch Sex Behav* 32:93, 2003.
441. **Faiman C, Winter JS**, The control of gonadotropin secretion in complete testicular feminization, *J Clin Endocrinol Metab* 39:631, 1974.
442. **Boyar RM, Moore RJ, Rosner W, Aiman J, Chipman J, Madden JD, Marks JF, Griffin JE**, Studies of gonadotropin-gonadal dynamics in patients with androgen insensitivity, *J Clin Endocrinol Metab* 47:1116, 1978.
443. **Sarpel U, Palmer SK, Dolgin SE**, The incidence of complete androgen insensitivity in girls with inguinal hernias and assessment of screening by vaginal length measurement, *J Pediatr Surg* 40:133, 2005.
444. **Tanaka YO, Mesaki N, Kurosaki Y, Nishida M, Itai Y**, Testicular feminization: role of MRI in diagnosing this rare male pseudohermaphroditism, *J Comput Assist Tomogr* 22:884, 1998.
445. **Manuel M, Katayama KP, Jones HW Jr**, The age of occurrence of gonadal tumors in intersex patients with a Y chromosome, *Am J Obstet Gynecol* 124:293, 1976.
446. **Rutgers JL, Scully RE**, The androgen insensitivity syndrome (testicular feminization): a clinicopathologic study of 43 cases, *Int J Gynecol Pathol* 10:126, 1991.
447. **Simpson JL**, Genetics of sexual differentiation, In: Rock JA, Carpenter SE, eds. *Pediatric and Adolescent Gynecology*, Raven Press, New York, 1992, p. 1.
448. **Gardo S, Papp Z**, Clinical variations of testicular intersexuality in a family, *J Med Genet* 11:267, 1974.
449. **Chu J, Zhang R, Zhao Z, Zou W, Han Y, Qi Q, Zhang H, Wang JC, Tao S, Liu X, Luo Z**, Male fertility is compatible with an Arg(840)Cys substitution in the AR in a large Chinese family affected with divergent phenotypes of AR insensitivity syndrome, *J Clin Endocrinol Metab* 87:347, 2002.
450. **Wilson JD, Harrod MJ, Goldstein JL, Hemsell DL, MacDonald PC**, Familial incomplete male pseudohermaphroditism, type 1. Evidence for androgen resistance and variable clinical manifestations in a family with the Reifenstein syndrome, *N Engl J Med* 290:1097, 1974.
451. **Migeon CJ, Wisniewski AB, Gearhart JP, Meyer-Bahlburg HF, Rock JA, Brown TR, Casella SJ, Maret A, Ngai KM, Money J, Berkovitz GD**, Ambiguous genitalia with perineoscrotal hypospadias in 46,XY individuals: long-term medical, surgical, and psychosexual outcome, *Pediatrics* 110:e31, 2002.
452. **Melo KF, Mendonca BB, Billerbeck AE, Costa EM, Inacio M, Silva FA, Leal AM, Latronico AC, Arnhold IJ**, Clinical, hormonal, behavioral, and genetic characteristics of androgen insensitivity syndrome in a Brazilian cohort: five novel mutations in the androgen receptor gene, *J Clin Endocrinol Metab* 88:3241, 2003.
453. **Bouvattier C, Mignot B, Lefevre H, Morel Y, Bougneres P**, Impaired sexual activity in male adults with partial androgen insensitivity, *J Clin Endocrinol Metab* 91:3310, 2006.
454. **Aiman J, Griffin JE, Gazak JM, Wilson JD, MacDonald PC**, Androgen insensitivity as a cause of infertility in otherwise normal men, *N Engl J Med* 300:223, 1979.
455. **Aiman J, Griffin JE**, The frequency of androgen receptor deficiency in infertile men, *J Clin Endocrinol Metab* 54:725, 1982.
456. **Morrow AF, Gyorki S, Warne GL, Burger HG, Bangah ML, Outch KH, Mirovics A, Baker HW**, Variable androgen receptor levels in infertile men, *J Clin Endocrinol Metab* 64:1115, 1987.
457. **Grino PB, Griffin JE, Cushard WG Jr, Wilson JD**, A mutation of the androgen receptor associated with partial androgen resistance, familial gynecomastia, and fertility, *J Clin Endocrinol Metab* 66:754, 1988.
458. **Pinsky L, Kaufman M, Killinger DW**, Impaired spermatogenesis is not an obligate expression of receptor-defective androgen resistance, *Am J Med Genet* 32:100, 1989.
459. **Madden JD, Walsh PC, MacDonald PC, Wilson JD**, Clinical and endocrinologic characterization of a patients with the syndrome of incomplete testicular feminization, *J Clin Endocrinol Metab* 41:751, 1975.

460. **McPhaul MJ, Marcelli M, Zoppi S, Griffin JE, Wilson JD**, Genetic basis of endocrine disease 4: the spectrum of mutations in the androgen receptor gene that causes androgen resistance, *J Clin Endocrinol Metab* 76:17, 1993.
461. **McPhaul MJ, Marcelli M, Tilley WD, Griffin JE, Isidro-Gutierrez RF, Wilson JD**, Molecular basis of androgen resistance in a family with a qualitative abnormality of the androgen receptor and responsive to high-dose androgen therapy, *J Clin Invest* 87:1413, 1991.
462. **Gao T, Marcelli M, McPhaul MJ**, Transcriptional activation and transient expression of the human androgen receptor, *J Steroid Biochem Mol Biol* 59: 9, 1996.
463. **Boehmer AL, Brinkmann O, Bruggenwirth H, van Assendelft C, Otten BJ, Verleun-Mooijman MC, Niermeijer MF, Brunner HG, Rouwe CW, Waelkens JJ, Oostdijk W, Kleijer WJ, van der Kwast TH, de Vroede MA, Drop SL**, Genotype versus phenotype in families with androgen insensitivity syndrome, *J Clin Endocrinol Metab* 86:4151, 2001.
464. **Ahmed SF, Cheng A, Dovey L, Hawkins JR, Martin H, Rowland J, Shimura N, Tait AD, Hughes IA**, Phenotypic features, androgen receptor binding, and mutational analysis in 278 clinical cases reported as androgen insensitivity syndrome, *J Clin Endocrinol Metab* 85:658, 2000.
465. **Adachi M, Takayanagi R, Tomura A, Imasaki K, Kato S, Goto K, Yanase T, Ikuyama S, Nawata H**, Androgen-insensitivity syndrome as a possible coactivator disease, *N Engl J Med* 343:856, 2000.
466. **Holterhus PM, Bruggenwirth HT, Hiort O, Kleinkauf-Houcken A, Kruse K, Sinnecker GH, Brinkmann AO**, Mosaicism due to a somatic mutation of the androgen receptor gene determines phenotype in androgen insensitivity syndrome, *J Clin Endocrinol Metab* 82:3584, 1997.
467. **Kohler B, Lumbroso S, Leger J, Audran F, Grau ES, Kurtz F, Pinto G, Salerno M, Semitcheva T, Czernichow P, Sultan C**, Androgen insensitivity syndrome: somatic mosaicism of the androgen receptor in seven families and consequences for sex assignment and genetic counseling, *J Clin Endocrinol Metab* 90:106, 2005.
468. **Pryor JL, Kent-First M, Muallem A, Van Bergen AH, Nolten WE, Meisner L, Roberts KP**, Microdeletions in the Y chromosome of infertile men, *N Engl J Med* 336:534, 1997.
469. **McPhaul MJ, Deslypere JP, Allman DR, Gerard RD**, The adenovirus-mediated delivery of a reporter gene permits the assessment of androgen receptor function in genital skin fibroblast cultures. Stimulation of Gs and inhibition of G(o), *J Biol Chem* 268:26063, 1993.
470. **Zoppi S, Wilson CM, Harbison MD, Griffin JE, Wilson JD, McPhaul MJ, Marcelli M**, Complete testicular feminization caused by an amino-terminal truncation of the androgen receptor with downstream initiation, *J Clin Invest* 91:1105, 1993.
471. **Lobaccaro JM, Belon C, Lumbroso S, Olewniczack G, Carre-Pigeon F, Job JC, Chaussain JL, Toublanc JE, Sultan C**, Molecular prenatal diagnosis of partial androgen insensitivity syndrome based on the Hind III polymorphism of the androgen receptor gene, *Clin Endocrinol (Oxf)* 40:297, 1994.
472. **Edwards A, Hammond HA, Jin L, Caskey CT, Chakraborty R**, Genetic variation at five trimeric and tetrameric tandem repeat loci in four human population groups, *Genomics* 12:241, 1992.
473. **Grino PB, Isidro-Gutierrez RF, Griffin JE, Wilson JD**, Androgen resistance associated with a qualitative abnormality of the androgen receptor and responsive to high dose androgen therapy, *J Clin Endocrinol Metab* 68:578, 1989.
474. **Ong YC, Wong HB, Adaikan G, Yong EL**, Directed pharmacological therapy of ambiguous genitalia due to an androgen receptor gene mutation, *Lancet* 354:1444, 1999.
475. **Foresta C, Bettella A, Ferlin A, Garolla A, Moro E, Baldinotti F, Simi P, Dallapiccola B**, Response to local dihydrotestosterone treatment in a patient with partial androgen-insensitivity syndrome due to a novel mutation in the androgen receptor gene, *Am J Med Genet* 107:259, 2002.
476. **Weidemann W, Peters B, Romalo G, Spindler K-D, Schweikert H-U**, Response to androgen treatment in a patient with partial androgen insensitivity and a mutation in the deoxyribonucleic acid-binding domain of the androgen receptor, *J Clin Endocrinol Metab* 83:1173, 1998.
477. **Slijper FM, Frets PG, Boehmer AL, Drop SL, Niermeijer MF**, Androgen insensitivity syndrome (AIS): emotional reactions of parents and adult patients to the clinical diagnosis of AIS and its confirmation by

- androgen receptor gene mutation analysis, *Horm Res* 53:9, 2000.
478. **Levin HS**, Tumors of the testis in intersex syndromes, *Urol Clin North Am* 27:543, 2000.
479. **Wooster R, Mangion J, Eeles R, Smith S, Dowsett M, Averill D, Barrett-Lee P, Easton DF, Ponder BA, Stratton MR**, A germline mutation in the androgen receptor gene in two brothers with breast cancer and Reifenstein syndrome, *Nat Genet* 2:132, 1992.
480. **Kremer H, Kraaij R, Toledo SP, Post M, Fridman JB, Hayashida CY, van Reen M, Milgrom E, Ropers HH, Mariman E**, et al., Male pseudohermaphroditism due to a homozygous missense mutation of the luteinizing hormone receptor gene, *Nat Genet* 9:160, 1995.
481. **Themmen AP, Verhoef-Post M**, LH receptor defects, *Semin Reprod Med* 20:199, 2002.
482. **Martens JW, Verhoef-Post M, Abelin N, Ezabella M, Toledo SP, Brunner HG, Themmen AP**, A homozygous mutation in the luteinizing hormone receptor causes partial Leydig cell hypoplasia: correlation between receptor activity and phenotype, *Mol Endocrinol* 12:775, 1998.
483. **Martens JW, Lumbroso S, Verhoef-Post M, Georget V, Richter-Unruh A, Szarras-Czapnik M, Romer TE, Brunner HG, Themmen AP, Sultan C**, Mutant luteinizing hormone receptors in a compound heterozygous patient with complete Leydig cell hypoplasia: abnormal processing causes signaling deficiency, *J Clin Endocrinol Metab* 87:2506, 2002.
484. **Toppari J, Kaleva M, Virtanen HE, Main KM, Skakkebaek NE**, Luteinizing hormone in testicular descent, *Mol Cell Endocrinol* 269:34, 2007.
485. **Ferlin A, Zuccarello D, Garolla A, Selice R, Foresta C**, Hormonal and genetic control of testicular descent, *Reprod Biomed Online* 15:659, 2007.
486. **Imbeaud S, Belville C, Messika-Zeitoun L, Rey R, di Clemente N, Josso N, Picard JY**, A 27 base-pair deletion of the anti-mullerian type II receptor gene is the most common cause of the persistent mullerian duct syndrome, *Hum Mol Genet* 5:1269, 1996.
487. **Jamin SP, Arango NA, Mishina Y, Behringer RR**, Genetic studies of MIS signalling in sexual development, *Novartis Found Symp* 244:157, 2002.
488. **Picard JY, Belville C**, [Genetics and molecular pathology of anti-Mullerian hormone and its receptor], *J Soc Biol* 196:217, 2002.
489. **Turner HH**, A syndrome of infantilism, congenital webbed neck, and cubitus valgus, *Endocrinology* 28:566, 1938.
490. **Cockwell A, MacKenzie M, Youings S, Jacobs P**, A cytogenetic and molecular study of a series of 45,X fetuses and their parents, *J Med Genet* 28:151, 1991.
491. **Sybert VP, McCauley E**, Turner's syndrome, *N Engl J Med* 351:1227, 2004.
492. **Hook EB, Warburton D**, The distribution of chromosomal genotypes associated with Turner's syndrome: livebirth prevalence rates and evidence for diminished fetal mortality and severity in genotypes associated with structural X abnormalities or mosaicism, *Hum Genet* 64:24, 1983.
493. **Jacobs PA, Betts PR, Cockwell AE, Crolla JA, Mackenzie MJ, Robinson DO, Youings SA**, A cytogenetic and molecular reappraisal of a series of patients with Turner's syndrome, *Ann Hum Genet* 54:209, 1990.
494. **Nielsen J, Wohlert M**, Chromosome abnormalities found among 34,910 newborn children: results from a 13-year incidence study in Arhus, Denmark, *Hum Genet* 87:81, 1991.
495. **Binder G, Koch A, Wajs E, Ranke MB**, Nested polymerase chain reaction study of 53 cases with Turner's syndrome: is cytogenetically undetected Y mosaicism common?, *J Clin Endocrinol Metab* 80:3532, 1995.
496. **Rao E, Weiss B, Fukami M, Rump A, Niesler B, Mertz A, Muroya K, Binder G, Kirsch S, Winkelmann M, Nordsiek G, Heinrich U, Breuning MH, Ranke MB, Rosenthal A, Ogata T, Rappold GA**, Pseudoautosomal deletions encompassing a novel homeobox gene cause growth failure in idiopathic short stature and Turner syndrome, *Nat Genet* 16:54, 1997.
497. **Ross JL, Kowal K, Quigley CA, Blum WF, Cutler GB Jr, Crowe B, Hovanes K, Elder FF, Zinn AR**, The phenotype of short stature homeobox gene (SHOX) deficiency in childhood: contrasting children with Leri-Weill dyschondrosteosis and Turner syndrome, *J Pediatr* 147:499, 2005.
498. **Sagi L, Zuckerman-Levin N, Gawlik A, Ghizzoni L, Buyukgebiz A, Rakover Y, Bistritzer T, Admoni**



- O, Vottero A, Baruch O, Fares F, Malecka-Tendera E, Hochberg Z**, Clinical significance of the parental origin of the X chromosome in turner syndrome, *J Clin Endocrinol Metab* 92:846, 2007.
499. **Pasquino AM, Passeri F, Pucarelli I, Segni M, Municchi G**, Spontaneous pubertal development in Turner's syndrome. Italian Study Group for Turner's Syndrome, *J Clin Endocrinol Metab* 82:1810, 1997.
500. **Massarano AA, Adams JA, Preece MA, Brook CG**, Ovarian ultrasound appearances in Turner syndrome, *J Pediatr* 114:568, 1989.
501. **Chang P, Tsau YK, Tsai WY, Tsai WS, Hou JW, Hsiao PH, Lee JS**, Renal malformations in children with Turner's syndrome, *J Formos Med Assoc* 99:796, 2000.
502. **Flynn MT, Ekstrom L, De Arce M, Costigan C, Hoey HM**, Prevalence of renal malformation in Turner syndrome, *Pediatr Nephrol* 10:498, 1996.
503. **Gravholt CH, Juul S, Naeraa RW, Hansen J**, Morbidity in Turner syndrome, *J Clin Epidemiol* 51:147, 1998.
504. **Gotzsche CO, Krag-Olsen B, Nielsen J, Sorensen KE, Kristensen BO**, Prevalence of cardiovascular malformations and association with karyotypes in Turner's syndrome, *Arch Dis Child* 71:433, 1994.
505. **Elsheikh M, Casadei B, Conway GS, Wass JA**, Hypertension is a major risk factor for aortic root dilatation in women with Turner's syndrome, *Clin Endocrinol (Oxf)* 54:69, 2001.
506. **Sachdev V, Matura LA, Sidenko S, Ho VB, Arai AE, Rosing DR, Bondy CA**, Aortic valve disease in Turner syndrome, *J Am Coll Cardiol* 51:1904, 2008.
507. **Ho VB, Bakalov VK, Cooley M, Van PL, Hood MN, Burklow TR, Bondy CA**, Major vascular anomalies in Turner syndrome: prevalence and magnetic resonance angiographic features, *Circulation* 110:1694, 2004.
508. **Bondy CA, Ceniceros I, Van PL, Bakalov VK, Rosing DR**, Prolonged rate-corrected QT interval and other electrocardiogram abnormalities in girls with Turner syndrome, *Pediatrics* 118:e1220, 2006.
509. **Dalla Pozza R, Bechtold S, Urschel S, Netz H, Schwarz HP**, QTc interval prolongation in children with Turner syndrome: the results of exercise testing and 24-h ECG, *Eur J Pediatr* 168:59, 2009.
510. **Landin-Wilhelmsen K, Bryman I, Wilhelmsen L**, Cardiac malformations and hypertension, but not metabolic risk factors, are common in Turner syndrome, *J Clin Endocrinol Metab* 86:4166, 2001.
511. **Nathwani NC, Unwin R, Brook CG, Hindmarsh PC**, The influence of renal and cardiovascular abnormalities on blood pressure in Turner syndrome, *Clin Endocrinol (Oxf)* 52:371, 2000.
512. **Gravholt CH, Vestergaard P, Hermann AP, Mosekilde L, Brixen K, Christiansen JS**, Increased fracture rates in Turner's syndrome: a nationwide questionnaire survey, *Clin Endocrinol (Oxf)* 59:89, 2003.
513. **Rubin K**, Turner syndrome and osteoporosis: mechanisms and prognosis, *Pediatrics* 102:481, 1998.
514. **Denniston A**, Turner's syndrome, *Lancet* 358:2169, 2001.
515. **Chrousos GA, Ross JL, Chrousos G, Chu FC, Kenigsberg D, Cutler G Jr, Loriaux DL**, Ocular findings in Turner syndrome. A prospective study, *Ophthalmology* 91:926, 1984.
516. **Adhikary HP**, Ocular manifestations of Turner's syndrome, *Trans Ophthalmol Soc U K* 101(Pt 4):395, 1981.
517. **Elsheikh M, Wass JA, Conway GS**, Autoimmune thyroid syndrome in women with Turner's syndrome—the association with karyotype, *Clin Endocrinol (Oxf)* 55:223, 2001.
518. **Syven L, Hagenfeldt K, Brondum-Nielsen K, von Schoultz B**, Middle-aged women with Turner's syndrome. Medical status, hormonal treatment and social life, *Acta Endocrinol (Copenh)* 125:359, 1991.
519. **Hjerrild BE, Mortensen KH, Gravholt CH**, Turner syndrome and clinical treatment, *Br Med Bull* 86:77, 2008.
520. **Bonamico M, Pasquino AM, Mariani P, Danesi HM, Culasso F, Mazzanti L, Petri A, Bona G**, Prevalence and clinical picture of celiac disease in Turner syndrome, *J Clin Endocrinol Metab* 87:5495, 2002.
521. **Saenger P**, Turner's syndrome, *N Engl J Med* 335:1749, 1996.
522. **Gravholt CH**, Epidemiological, endocrine and metabolic features in Turner syndrome, *Eur J Endocrinol* 151:657, 2004.
523. **Migeon BR, Luo S, Stasiowski BA, Jani M, Axelman J, Van Dyke DL, Weiss L, Jacobs PA, Yang-Feng TL, Wiley JE**, Deficient transcription of XIST from tiny ring X chromosomes in females with severe phenotypes, *Proc Natl Acad Sci U S A* 90:12025, 1993.
524. **Collins AL, Cockwell AE, Jacobs PA, Dennis NR**, A comparison of the clinical and cytogenetic findings in nine patients with a ring (X) cell line and 16 45,X patients, *J Med Genet* 31:528, 1994.

525. **Bender B, Puck M, Salbenblatt J, Robinson A**, Cognitive development of unselected girls with complete and partial X monosomy, *Pediatrics* 73:175, 1984.
526. **Russell HF, Wallis D, Mazzocco MM, Moshang T, Zackai E, Zinn AR, Ross JL, Muenke M**, Increased prevalence of ADHD in Turner syndrome with no evidence of imprinting effects, *J Pediatr Psychol* 31:945, 2006.
527. **McCauley E, Feuillan P, Kushner H, Ross JL**, Psychosocial development in adolescents with Turner syndrome, *J Dev Behav Pediatr* 22:360, 2001.
528. **Schoemaker MJ, Swerdlow AJ, Higgins CD, Wright AF, Jacobs PA**, Mortality in women with turner syndrome in Great Britain: a national cohort study, *J Clin Endocrinol Metab* 93:4735, 2008.
529. **Schoemaker MJ, Swerdlow AJ, Higgins CD, Wright AF, Jacobs PA**, Cancer incidence in women with Turner syndrome in Great Britain: a national cohort study, *Lancet Oncol* 9:239, 2008.
530. **Taipale P, Hiilesmaa V, Salonen R, Ylostalo P**, Increased nuchal translucency as a marker for fetal chromosomal defects, *N Engl J Med* 337:1654, 1997.
531. **Savendahl L, Davenport ML**, Delayed diagnoses of Turner's syndrome: proposed guidelines for change, *J Pediatr* 137:455, 2000.
532. **Azcona C, Bareille P, Stanhope R**, Lesson of the week: Turner's syndrome mosaicism in patients with a normal blood lymphocyte karyotype, *Br Med J* 318:856, 1999.
533. **Gemmill RM, Pearce-Birge L, Bixenman H, Hecht BK, Allanson JE**, Y chromosome-specific DNA sequences in Turner-syndrome mosaicism, *Am J Hum Genet* 41:157, 1987.
534. **Saenger P, Wikland KA, Conway GS, Davenport M, Gravholt CH, Hintz R, Hovatta O, Hulcrantz M, Landin-Wilhelmsen K, Lin A, Lippe B, Pasquino AM, Ranke MB, Rosenfeld R, Silberbach M**, Recommendations for the diagnosis and management of Turner syndrome, *J Clin Endocrinol Metab* 86:3061, 2001.
535. **Gravholt CH, Fedder J, Naeraa RW, Müller J**, Occurrence of gonadoblastoma in females with Turner syndrome and Y chromosome material: a population study, *J Clin Endocrinol Metab* 85:3199, 2000.
536. **Medlej R, Lobaccaro JM, Berta P, Belon C, Leheup B, Toubiane JE, Weill J, Chevalier C, Dumas R, Sultan C**, Screening for Y-derived sex determining gene SRY in 40 patients with Turner syndrome, *J Clin Endocrinol Metab* 75:1289, 1992.
537. **Tsuchiya K, Reijo R, Page DC, Distechi CM**, Gonadoblastoma: molecular definition of the susceptibility region on the Y chromosome, *Am J Hum Genet* 57:1400, 1995.
538. **Frias JL, Davenport ML**, Health supervision for children with Turner syndrome, *Pediatrics* 111:692, 2003.
539. **Ari M, Bakalov VK, Hill S, Bondy CA**, The effects of growth hormone treatment on bone mineral density and body composition in girls with turner syndrome, *J Clin Endocrinol Metab* 91:4302, 2006.
540. **Sas TC, de Muinck Keizer-Schrama SM, Stijnen T, Jansen M, Otten BJ, Hoorweg-Nijman JJ, Vulsma T, Massa GG, Rouwe CW, Reeser HM, Gerver WJ, Gosen JJ, Rongen-Westerlaken C, Drop SL**, Normalization of height in girls with Turner syndrome after long-term growth hormone treatment: results of a randomized dose-response trial, *J Clin Endocrinol Metab* 84:4607, 1999.
541. **Reiter EO, Blethen SL, Baptista J, Price L**, Early initiation of growth hormone treatment allows age-appropriate estrogen use in Turner's syndrome, *J Clin Endocrinol Metab* 86:1936, 2001.
542. **Saenger P**, Growth-promoting strategies in Turner's syndrome, *J Clin Endocrinol Metab* 84:4345, 1999.
543. **Nilsson KO, Albertsson-Wikland K, Alm J, Aronson S, Gustafsson J, Hagenas L, Hager A, Ivarsson SA, Karlberg J, Kristrom B, Marcus C, Moell C, Ritzen M, Tuvemo T, Wattsgard C, Westgren U, Westphal O, Aman J**, Improved final height in girls with Turner's syndrome treated with growth hormone and oxandrolone, *J Clin Endocrinol Metab* 81:635, 1996.
544. **Rosenfeld RG, Attie KM, Frane J, Brasel JA, Burstein S, Cara JF, Chernausek S, Gotlin RW, Kuntze J, Lippe BM, Mahoney CP, Moore WV, Saenger P, Johanson AJ**, Growth hormone therapy of Turner's syndrome: beneficial effect on adult height, *J Pediatr* 132:319, 1998.
545. **Chernausek SD, Attie KM, Cara JF, Rosenfeld RG, Frane J**, Growth hormone therapy of Turner syndrome: the impact of age of estrogen replacement on final height. Genentech, Inc., Collaborative Study Group, *J Clin Endocrinol Metab* 85:2439, 2000.

546. **Quigley CA, Crowe BJ, Anglin DG, Chipman JJ**, Growth hormone and low dose estrogen in Turner syndrome: results of a United States multi-center trial to near-final height, *J Clin Endocrinol Metab* 87:2033, 2002.
547. **Shankar RK, Backeljauw PF**, Current best practice in the management of Turner syndrome, *Ther Adv Endocrinol Metab* 9:1, 2018.
548. **Practice Committee of American Society For Reproductive Medicine**, Increased maternal cardiovascular mortality associated with pregnancy in women with Turner syndrome, *Fertil Steril* 90:S185, 2008.
549. **Schwartz ID, Root AW**, The Klinefelter syndrome of testicular dysgenesis, *Endocrinol Metab Clin North Am* 20:153, 1991.
550. **Bojesen A, Juul S, Gravholt CH**, Prenatal and postnatal prevalence of Klinefelter syndrome: a national registry study, *J Clin Endocrinol Metab* 88:622, 2003.
551. **Paulsen CA, Gordon DL, Carpenter RW, Gandy HM, Drucker WD**, Klinefelter's syndrome and its variants: a hormonal and chromosomal study, *Recent Prog Horm Res* 24:321, 1968.
552. **Wang C, Baker HW, Burger HG, De Kretser DM, Hudson B**, Hormonal studies in Klinefelter's syndrome, *Clin Endocrinol (Oxf)* 4:399, 1975.
553. **Bender BG, Linden MG, Robinson A**, Neuropsychological impairment in 42 adolescents with sex chromosome abnormalities, *Am J Med Genet* 48: 169, 1993.
554. **Simm PJ, Zacharin MR**, The psychosocial impact of Klinefelter syndrome—a 10 year review, *J Pediatr Endocrinol Metab* 19:499, 2006.
555. **Ross JL, Roeltgen DP, Stefanatos G, Benecke R, Zeger MP, Kushner H, Ramos P, Elder FF, Zinn AR**, Cognitive and motor development during childhood in boys with Klinefelter syndrome, *Am J Med Genet A* 146A:708, 2008.
556. **Weiss JR, Moysich KB, Swede H**, Epidemiology of male breast cancer, *Cancer Epidemiol Biomarkers Prev* 14:20, 2005.
557. **Volkl TM, Langer T, Aigner T, Greess H, Beck JD, Rauch AM, Dorr HG**, Klinefelter syndrome and mediastinal germ cell tumors, *Am J Med Genet A* 140:471, 2006.
558. **Bojesen A, Juul S, Birkebaek NH, Gravholt CH**, Morbidity in Klinefelter syndrome: a Danish register study based on hospital discharge diagnoses, *J Clin Endocrinol Metab* 91:1254, 2006.
559. **Swerdlow AJ, Schoemaker MJ, Higgins CD, Wright AF, Jacobs PA**, Cancer incidence and mortality in men with Klinefelter syndrome: a cohort study, *J Natl Cancer Inst* 97:1204, 2005.
560. **Lanfranco F, Kamischke A, Zitzmann M, Nieschlag E**, Klinefelter's syndrome, *Lancet* 364:273, 2004.
561. **Kim KR, Kwon Y, Joung JY, Kim KS, Ayala AG, Ro JY**, True hermaphroditism and mixed gonadal dysgenesis in young children: a clinicopathologic study of 10 cases, *Mod Pathol* 15:1013, 2002.
562. **Zah W, Kalderon AE, Tucci JR**, Mixed gonadal dysgenesis, *Acta Endocrinol Suppl (Copenh)* 197:1, 1975.
563. **Mendez JP, Ulloa-Aguirre A, Kofman-Alfaro S, Mutchinick O, Fernandez-del-Castillo C, Reyes E, Perez-Palacios G**, Mixed gonadal dysgenesis: clinical, cytogenetic, endocrinological, and histopathological findings in 16 patients, *Am J Med Genet* 46:263, 1993.
564. **Boklage CE**, Embryogenesis of chimeras, twins and anterior midline asymmetries, *Hum Reprod* 21:579, 2006.
565. **Tippett P**, Blood group chimeras. A review, *Vox Sang* 44:333, 1983.
566. **Bromilow IM, Duguid JK**, Blood group chimaerism: a possible further example, *Med Lab Sci* 48:212, 1991.
567. **Mifsud NA, Haddad AP, Hart CF, Holdsworth R, Condon JA, Swain M, Sparrow RL**, Serologic and molecular investigations of a chimera, *Immunohematology* 15:100, 1999.
568. **Drexler C, Glock B, Vadon M, Staudacher E, Dauber EM, Ulrich S, Reisacher RB, Mayr WR, Lanzer G, Wagner T**, Tetragametic chimerism detected in a healthy woman with mixed-field agglutination reactions in ABO blood grouping, *Transfusion* 45:698, 2005.
569. **Verp MS, Harrison HH, Ober C, Oliveri D, Amarose AP, Lindgren V, Talerman A**, Chimerism as the etiology of a 46,XX/46,XY fertile true hermaphrodite, *Fertil Steril* 57:346, 1992.
570. **Strain L, Dean JC, Hamilton MP, Bonthron DT**, A true hermaphrodite chimera resulting from embryo amalgamation after in vitro fertilization, *N Engl J Med* 338:166, 1998.

571. **Lee PA**, A perspective on the approach to the intersex child born with genital ambiguity, *J Pediatr Endocrinol Metab* 17:133, 2004.
572. **Cashman S, Reidy P, Cody K, Lemay C**, Developing and measuring progress toward collaborative, integrated, interdisciplinary health care teams, *J Interprof Care* 18:183, 2004.
573. **Frader J, Alderson P, Asch A, Aspinall C, Davis D, Dreger A, Edwards J, Feder EK, Frank A, Hedley LA, Kittay E, Marsh J, Miller PS, Mouradian W, Nelson H, Parens E**, Health care professionals and intersex conditions, *Arch Pediatr Adolesc Med* 158:426, 2004.
574. **Lipkin PH, Alexander J, Cartwright JD, Desch LW, Duby JC, Edwards DR, Elias ER, Johnson CP, Levey EB, Murphy NA, Myers S, Tilton AH, Crider B, Lollar D, Macias MM, McPherson M, Skipper SM**, Care coordination in the medical home: integrating health and related systems of care for children with special health care needs, *Pediatrics* 116:1238, 2005.
575. **Davidoff F, Federman DD**, Mixed gonadal dysgenesis, *Pediatrics* 52:725, 1973.
576. **Meyers-Seifer CH, Charest NJ**, Diagnosis and management of patients with ambiguous genitalia, *Semin Perinatol* 16:332, 1992.
577. **Phillip M, De Boer C, Pilpel D, Karplus M, Sofer S**, Clitoral and penile sizes of full term newborns in two different ethnic groups, *J Pediatr Endocrinol Metab* 9:175, 1996.
578. **Oberfield SE, Mondok A, Shahrivar F, Klein JF, Levine LS**, Clitoral size in full-term infants, *Am J Perinatol* 6:453, 1989.
579. **Callegari C, Everett S, Ross M, Brasel JA**, Anogenital ratio: measure of fetal virilization in premature and full-term newborn infants, *J Pediatr* 111: 240, 1987.
580. **Quigley CA, De Bellis A, Marschke KB, El-Awady MK, Wilson EM, French FS**, Androgen receptor defects: historical, clinical, and molecular perspectives, *Endocr Rev* 16:271, 1995.
581. **Siegel MJ**, Pediatric gynecologic sonography, *Radiology* 179:593, 1991.
582. **Clarkson MJ, Harley VR**, Sex with two SOX on: SRY and SOX9 in testis development, *Trends Endocrinol Metab* 13:106, 2002.
583. **Winter JSD, Faiman C**, The development of cyclic pituitary-gonadal function in adolescent females, *J Clin Endocrinol Metab* 37:714, 1973.
584. **Forest MG, Sizonenko PC, Cathiard AM, Bertrand J**, Hypophyso-gonadal function in humans during the first year of life. 1. Evidence for testicular activity in early infancy, *J Clin Invest* 53:819, 1974.
585. **Lutfallah C, Wang W, Mason JI, Chang YT, Haider A, Rich B, Castro-Magana M, Copeland KC, David R, Pang S**, Newly proposed hormonal criteria via genotypic proof for type II 3beta-hydroxysteroid dehydrogenase deficiency, *J Clin Endocrinol Metab* 87:2611, 2002.
586. **Misra M, MacLaughlin DT, Donahoe PK, Lee MM**, Measurement of Mullerian inhibiting substance facilitates management of boys with microphallus and cryptorchidism, *J Clin Endocrinol Metab* 87:3598, 2002.
587. **Faisal Ahmed S, Iqbal A, Hughes IA**, The testosterone: androstenedione ratio in male undermasculinization, *Clin Endocrinol (Oxf)* 53:697, 2000.
588. **Dessens AB, Cohen-Kettenis PT, Mellenbergh GJ, Koppe JG, Poll NE, Boer K**, Association of prenatal phenobarbital and phenytoin exposure with genital anomalies and menstrual disorders, *Teratology* 64:181, 2001.
589. **Reiner WG**, Assignment of sex in neonates with ambiguous genitalia, *Curr Opin Pediatr* 11:363, 1999.
590. **Daaboul J, Frader J**, Ethics and the management of the patient with intersex: a middle way, *J Pediatr Endocrinol Metab* 14:1575, 2001.
591. **Meyer-Bahlburg HF**, Gender and sexuality in classic congenital adrenal hyperplasia, *Endocrinol Metab Clin North Am* 30:155, 2001.
592. **Wisniewski AB, Migeon CJ, Meyer-Bahlburg HF, Gearhart JP, Berkovitz GD, Brown TR, Money J**, Complete androgen insensitivity syndrome: long-term medical, surgical, and psychosexual outcome, *J Clin Endocrinol Metab* 85:2664, 2000.
593. **Berenbaum SA, Bailey JM**, Effects on gender identity of prenatal androgens and genital appearance: evidence from girls with congenital adrenal hyperplasia, *J Clin Endocrinol Metab* 88:1102, 2003.
594. **Hines M**, Prenatal testosterone and gender-related behaviour, *Eur J Endocrinol* 155(Suppl 1):S115, 2006.

595. **Diamond M, Beh HG**, Changes in the management of children with intersex conditions, *Nat Clin Pract Endocrinol Metab* 4:4, 2008.
596. **Lee MM, Donahoe PK**, The infant with ambiguous genitalia, *Curr Ther Endocrinol Metab* 6:216, 1997.
597. Evaluation of the newborn with developmental anomalies of the external genitalia. American Academy of Pediatrics. Committee on Genetics, *Pediatrics* 106:138, 2000.
598. **Creighton SM, Minto CL, Steele SJ**, Objective cosmetic and anatomical outcomes at adolescence of feminising surgery for ambiguous genitalia done in childhood, *Lancet* 358:124, 2001.
599. **Minto CL, Liao LM, Woodhouse CR, Ransley PG, Creighton SM**, The effect of clitoral surgery on sexual outcome in individuals who have intersex conditions with ambiguous genitalia: a cross-sectional study, *Lancet* 361:1252, 2003.
600. **Schnitzer JJ, Donahoe PK**, Surgical treatment of congenital adrenal hyperplasia, *Endocrinol Metab Clin North Am* 30:137, 2001.
601. **Nihoul-Fekete C, Thibaud E, Lortat-Jacob S, Josso N**, Long-term surgical results and patient satisfaction with male pseudohermaphroditism or true hermaphroditism: a cohort of 63 patients, *J Urol* 175:1878, 2006.
602. **Migeon CJ, Wisniewski AB, Brown TR, Rock JA, Meyer-Bahlburg HF, Money J, Berkovitz GD**, 46,XY intersex individuals: phenotypic and etiologic classification, knowledge of condition, and satisfaction with knowledge in adulthood, *Pediatrics* 110:e32, 2002.
603. **Reiner WG, Gearhart JP, Jeffs R**, Psychosexual dysfunction in males with genital anomalies: late adolescence, Tanner stages IV to VI, *J Am Acad Child Adolesc Psychiatry* 38:865, 1999.
604. **Diamond M, Sigmundson HK**, Management of intersexuality. Guidelines for dealing with persons with ambiguous genitalia, *Arch Pediatr Adolesc Med* 151:1046, 1997.

---

# Normal and Abnormal Growth and Pubertal Development

In many societies throughout history, puberty has been a time of celebration. The changes that accompany puberty announce the transition from childhood to adulthood and the development of fertility. Puberty is the process of cognitive, psychosocial, and biologic maturation. Whereas growth and the development of secondary sexual characteristics are the most visible manifestations of the onset of puberty, changes in body composition and cognitive development are no less significant.<sup>1</sup> Puberty can be a difficult transition for many adolescents, even when it progresses normally, and presents substantially greater challenges when its onset is premature or delayed. The recent trend toward an earlier pubertal maturation and some of its consequences, notably earlier sexuality and the problem of teen pregnancy, make it all the more important to understand the physiology of normal puberty.

This chapter focuses first on the endocrinology and physiology of normal puberty, to provide the foundation for subsequent discussion of the pathophysiology, diagnosis, and management of abnormalities of growth and pubertal development.

# THE ENDOCRINOLOGY OF NORMAL PUBERTY

---

The hypothalamus, anterior pituitary gland, and gonads of the fetus, neonate, infant, and prepubertal child are all capable of secreting hormones in adult concentrations. The key to understanding the endocrinology of puberty lies in first understanding the mechanisms that govern the hypothalamic-pituitary-gonadal axis.

# The Ontogeny of the Hypothalamic-Pituitary-Gonadal Axis

The “hypothalamic pulse generator,” the term chosen by Ernst Knobil to describe the rhythmic, pulsatile nature of gonadotropin-releasing hormone (GnRH) secretion,<sup>2</sup> consists of approximately 1,500–2,000 specialized neurosecretory cells in the arcuate nucleus, located in the medial basal hypothalamus. The resident GnRH neurons exhibit spontaneous “autorhythmicity” and function as an oscillator in the pulsatile secretion of GnRH.<sup>3,4</sup> In response to the pulsatile GnRH signal, pituitary gonadotropes, which contain plasma membrane GnRH receptors, secrete follicle-stimulating hormone (FSH) and luteinizing hormone (LH), also in a pulsatile manner. In turn, the episodic gonadotropin signal stimulates maturation of the germinal elements of the gonads and is transmitted into the pulsatile secretion of sex steroids. Ultimately, the patterns of gonadotropin and gonadal steroid secretion during fetal life, infancy, childhood, adolescence, and adulthood primarily reflect changes in the activity of the hypothalamic pulse generator.

## Fetal Life and Infancy

The hypothalamic-pituitary-gonadal axis becomes functional even before birth. Neurons that synthesize GnRH originate in the olfactory placode and migrate to the hypothalamus between 6 and 9 weeks of gestation.<sup>5</sup> By 10 weeks, the hypothalamus contains significant amounts of GnRH.<sup>6</sup> Development of the hypothalamic-pituitary portal venous system begins between 9 and 10 weeks of gestation and is completed by 19–20 weeks.<sup>7</sup> Consequently, FSH and LH concentrations in fetal pituitary glands increase dramatically soon thereafter. The pituitary begins to secrete FSH and LH into the fetal circulation by week 12.<sup>8</sup> Fetal serum gonadotropin levels rise progressively, reaching a peak between 20 and 24 weeks<sup>9</sup> and then decrease steadily over the last 10 weeks of pregnancy, probably due to a developed sensitivity to the negative feedback effects of high circulating estrogen and progesterone concentrations derived from the placenta.<sup>10,11</sup>

After birth, steroid levels fall precipitously due to the loss of maternal and placental hormones, allowing the newborn’s hypothalamic-pituitary-gonadal axis to escape their suppressive effects. The characteristic pulsatile pattern of hypothalamic GnRH secretion emerges,<sup>12,13</sup> and serum gonadotropin concentrations rise again promptly, with a striking sex difference; FSH rises to a greater extent in females and LH to a greater extent in males.<sup>11</sup> In female infants, FSH concentrations occasionally reach levels even greater than those observed in the normal adult menstrual cycle.<sup>14,15</sup> Consequently, waves of ovarian follicular development begin, and estradiol levels during the first few



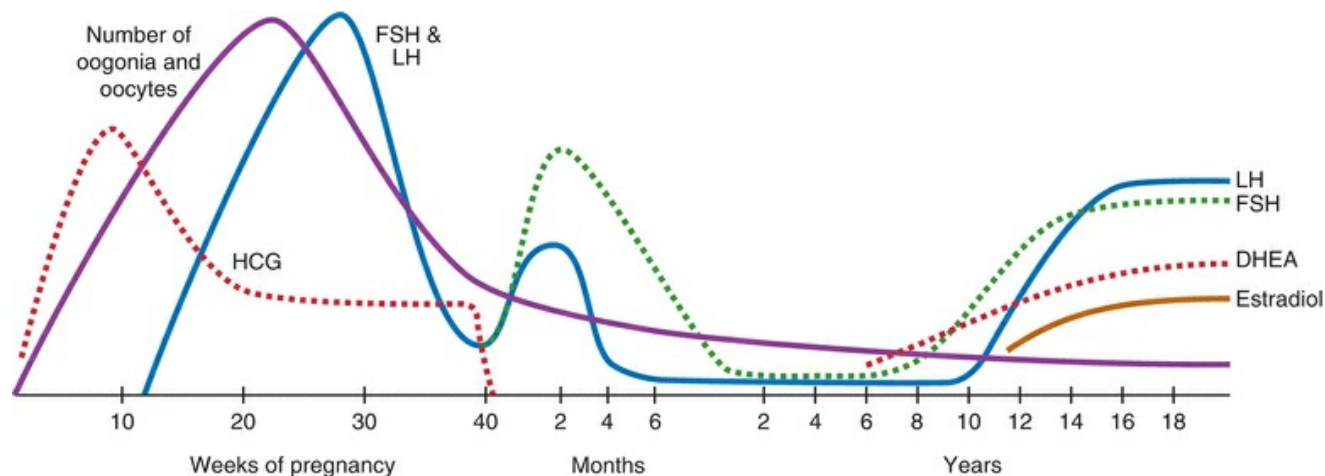
months of life are comparable to those observed during the midfollicular phase of the menstrual cycle.<sup>16</sup> In male infants, elevated LH levels stimulate increased testosterone secretion from the testes. Gonadotropin and gonadal steroid levels peak at about 3–6 months in boys and 12–18 months in girls and steadily decline thereafter, presumably because normal negative feedback mechanisms become fully functional. By approximately 9–12 months of age in boys and 24–36 months in girls, gonadotropin concentrations fall to typical prepubertal levels, remaining at very low concentrations until the onset of puberty.<sup>11</sup> Suppression of hypothalamic pulse generator activity is less intense and shorter in duration in females than in males, probably reflecting the influence of testosterone on hypothalamic programming.<sup>17</sup>

## Childhood and Early Adolescence

During the interval between infancy and puberty, known as the “juvenile pause” in nonhuman primates, the hypothalamic-pituitary-gonadal axis lies dormant. Normal ovulatory menstrual cycles can be induced in prepubertal female monkeys by administering a higher-amplitude pulsatile infusion of exogenous GnRH, indicating that neither the anterior pituitary nor the gonads are the limiting factor.<sup>18</sup> Although the GnRH pulse generator is active, the frequency and amplitude of pulsatile GnRH secretion generally are irregular and very low.<sup>19,20,21,22</sup> Low-amplitude pulses of gonadotropin secretion can be detected in prepubertal children as young as 5 years of age, primarily during sleep.<sup>22,23,24</sup> FSH levels rise more than LH, but there is no detectable increase in steroid hormone concentrations.

For a long time, the prevailing theory to explain the juvenile pause that precedes puberty envisioned a hypothalamic “gonadostat” controlling the level of sensitivity to the central negative feedback actions of gonadal steroids. In that context, the changing patterns of gonadotropin secretion were attributed to changes in the “gonadostat” setting. Decreasing gonadotropin levels in late infancy and sustained low concentrations during childhood reflected a rising and ultimately high sensitivity to even very low levels of sex steroid feedback, and increasing gonadotropin concentrations at the onset of puberty reflected a decrease in feedback sensitivity.<sup>25,26</sup> The “gonadostat” theory prevailed until cross-sectional and longitudinal studies in children with gonadal dysgenesis revealed a similar, but exaggerated, “diphasic” pattern of gonadotropin secretion. Serum gonadotropin levels in girls with Turner syndrome are markedly elevated in infancy, decline to very low levels during childhood, and rise again to grossly high concentrations at pubertal age, all in the absence of any possible change in the level of negative feedback from gonadal steroids.<sup>27</sup> These and similar observations in castrate nonhuman primates demonstrated that steroid hormone feedback affects the amount, but not the pattern, of gonadotropin secretion, contradicting the traditional

“gonadostat” theory and establishing a new paradigm. The typical “diphasic” pattern of gonadotropin secretion from infancy to puberty results primarily from changing levels of central inhibition of pulsatile GnRH secretion and, to a lesser extent, from a high sensitivity to low levels of gonadal steroid feedback (Figure 9.1).



**FIGURE 9.1**

## Puberty

About 1 year before breast budding in prepubertal girls, the character of nocturnal pulses of gonadotropin secretion changes with LH levels exceeding those of FSH. Breast budding occurs when the nocturnal pulses of gonadotropin secretion become great enough to generate detectable coincident increases in serum estradiol concentrations. At that time, LH peak amplitude increases about 10-fold, whereas FSH pulse amplitude only doubles, resulting in a marked decrease in the serum FSH/LH ratio.<sup>22,24</sup> The change reflects an increase in pituitary responsiveness to GnRH, which has a priming effect on pituitary LH secretion and increases the number of GnRH receptors on gonadotropes (up-regulation). Gonadotropes first increase their capacity for response to GnRH by synthesis and later by secretion of gonadotropins. Pulse frequency also increases, but to a much lesser extent. Gonadotropin pulses become diurnal and the duration of increases in estradiol levels becomes more prolonged. As puberty progresses, the amplitude of pulsatile LH secretion increases further, to levels 20–40 times greater than those detected during prepubertal years, probably reflecting the influence of rising estradiol levels at both the hypothalamic and pituitary levels. Although nocturnal pulse amplitudes are still greatest, significant pulses occur during daytime, and basal LH levels become detectable.<sup>22</sup> LH bioactivity also increases, due to changes in glycosylation.<sup>28</sup>

In response to increasing gonadotropin secretion, basal estradiol levels increase progressively.<sup>20</sup> Inhibin B levels, which are low or undetectable in prepubertal girls, increase sharply in midpuberty and then decline in its later stages, first reflecting increasing ovarian stimulation and then the onset of the menstrual cycle and the appearance of a luteal phase, when levels are low.<sup>29</sup> Inhibin A concentrations, undetectable or very low through early puberty, increase gradually thereafter but reach adult levels only after menarche, consistent with the corpus luteum being the primary source.<sup>29</sup> Menarche occurs in late puberty, after a yearlong rise in daily estrogen production,<sup>30</sup> probably when estradiol and inhibin B levels become sufficient to exert significant negative feedback on gonadotropin secretion, resulting in cyclic estrogen production. Cycle length and menstrual characteristics vary until the positive feedback relationship between estradiol and gonadotropin secretion matures and ovulation becomes established, often a year or more after menarche.

## Central Control Mechanisms

Some of the factors governing the “neuroendocrine switch” for the GnRH pulse generator that is “on” in early infancy, turns “off” during childhood, and switches back “on” again at puberty have now been identified. Most of the important work on the neuroendocrinology of puberty has been performed in nonhuman primate models. The list of factors that modulate the activity of the hypothalamic-pituitary-gonadal axis includes both inhibitory and excitatory neurotransmitters and peptides.

## Gamma-Aminobutyric Acid

Gamma-aminobutyric acid (GABA) is an inhibitory neurotransmitter produced by specialized neurons in the hypothalamus and has an important role in regulating the activity of the GnRH pulse generator. Elegant hypothalamic perfusion studies have revealed that the release of GABA into the median eminence decreases as pulsatile GnRH secretion increases at the onset of puberty.<sup>31</sup> Conversely, central perfusion with a GABA<sub>A</sub> receptor antagonist (bicuculline) or the antisense oligodeoxynucleotide for the mRNA coding the GABA<sub>A</sub>-synthesizing enzyme (glutamate acid decarboxylase) stimulates GnRH release.<sup>31,32</sup> Chronic administration of bicuculline into the third ventricle induces precocious puberty and menarche in prepubertal female monkeys.<sup>33</sup> Evidence suggests that changes in the subunit composition of GABA<sub>A</sub> receptors may contribute to the disinhibition of pulsatile GnRH secretion at the onset of puberty.<sup>34</sup> These observations suggest that central GABA signaling is one of the factors that restrains GnRH neuronal activity during childhood.

## Neuropeptide Y

Neuropeptide NPY (NPY) is a hypothalamic peptide involved in the control of food intake behavior and reproductive function in adults. In castrate adult female monkeys, intracerebroventricular administration of NPY inhibits pulsatile GnRH release.<sup>35</sup> In males, the postnatal pattern of GnRH pulse generator activity is inversely related to NPY gene and protein expression in the medial basal hypothalamus, and central administration of an NPY receptor antagonist stimulates GnRH release in juveniles.<sup>36</sup> These observations suggest that NPY, like GABA, is an important component of the “neurobiologic brake” that restrains the GnRH pulse generator in prepubertal primates. However, others have observed that NPY levels increase in the median eminence at the onset of puberty,<sup>37</sup> that infusion of NPY into the median eminence increases GnRH release,<sup>38</sup> and that infusion of NPY antiserum into the median eminence did not stimulate GnRH secretion in prepubertal monkeys.<sup>37</sup> The varying effects of NPY appear to relate to the site of infusion within the brain and not on the steroid milieu.<sup>35</sup> Additional work will be required to clarify the role of NPY in the regulation of the hypothalamic pulse generator and the onset of puberty.

## Glutamate

Glutamate is an excitatory neurotransmitter in the hypothalamus and stimulates GnRH release via N-methyl-D-aspartate (NMDA) receptors both in vivo and in vitro.<sup>39</sup> An intravenous bolus of NMDA stimulates hypothalamic GnRH release,<sup>40</sup> and treatment with a specific glutamate receptor antagonist blocks the effect in nonhuman primates. Moreover, prolonged (16–30 weeks) intermittent NMDA stimulation (1 minute every 3 hours) activates the hypothalamic-pituitary-gonadal axis and stimulates precocious puberty and the initiation of spermatogenesis in juvenile males.<sup>41</sup> These observations suggest that glutamate signaling may play a role in the resurgence of pulsatile GnRH secretion at the onset of puberty.

## Kisspeptins

In just the past few years, kisspeptins have emerged as a critical component of the system that controls the level of GnRH neuronal activity between infancy and puberty. Kisspeptins are neuropeptides (encoded by the *KISS1* gene) that signal via the G-protein-coupled receptor, GPR54 (encoded by the *KISS1R* gene).<sup>42</sup> Interestingly, the first evidence of their importance in the regulation of the hypothalamic-pituitary-gonadal axis came from observations in humans. Several members of a large consanguineous family with hypogonadotropic hypogonadism and delayed puberty were found to harbor homozygous inactivating mutations for GPR54.<sup>43,44</sup> One affected compound heterozygote

exhibited an exaggerated pituitary response to exogenous pulsatile GnRH administration, suggesting a hypothalamic locus for the disorder.<sup>44</sup> More importantly, the observation also suggested that kisspeptin signaling via GPR54 might play a major role in the resurgence of pulsatile GnRH secretion at puberty in primates. The results of subsequent studies in nonhuman primates and humans strongly support that interpretation.

Neurons expressing KISS1 are located exclusively in the arcuate nucleus,<sup>45,46</sup> where GnRH neurons also express GPR54.<sup>42</sup> Kisspeptin release appears to be regulated by neurokinin B and dynorphin, which are coproduced by the same neurons in this region of the brain.<sup>47</sup> In castrate male and intact female monkeys, the pubertal resurgence of pulsatile GnRH secretion is associated with a nearly fivefold increase in KISS1 expression and, in females, also with an increase in KISS1R expression.<sup>48</sup> Hypothalamic kisspeptin secretion is distinctly pulsatile and highly correlated with that of GnRH.<sup>49</sup> An intermittent kisspeptin infusion can sustain pulsatile LH secretion in castrate juvenile animals after discontinuation of a priming pulsatile infusion of exogenous GnRH, but not in the presence of a GnRH receptor antagonist, indicating that the effect of kisspeptin is mediated via pulsatile GnRH secretion.<sup>48</sup> The observation that patients with inactivating mutations of GPR54 exhibit pulsatile LH secretion with low amplitude and normal frequency suggested that kisspeptin might only amplify and not stimulate GnRH pulse generator activity directly.<sup>44,50</sup> However, a continuous kisspeptin infusion, which down-regulates GPR54, suppresses both LH pulse amplitude and frequency, implying that kisspeptin has similar effects on pulsatile GnRH secretion.<sup>51,52</sup> Finally, an activating KISS1R mutation resulting in prolonged activation of the KISS1R signal transduction pathway has been described in a young girl with GnRH-dependent (central) precocious puberty.<sup>53</sup> **Taken together, these observations indicate that hypothalamic kisspeptin-GPR54 signaling is a key component of the neurobiologic mechanism that triggers the onset of puberty. They further suggest that kisspeptin neurons may provide the fuel for the hypothalamic GnRH pulse generator.** The report of undetectable serum gonadotropins in an infant boy bearing a loss-of-function mutation in the KISS1R gene suggests that kisspeptin input to the GnRH neuronal network also is necessary for the increased pulsatile GnRH secretion normally observed during early infancy.<sup>54</sup>

There is increasing evidence from studies in nonhuman primates that kisspeptin neurons also are involved in mediating the feedback actions of both testicular and ovarian hormones. In males, testosterone negative feedback, which regulates LH secretion by slowing the pace of pulsatile GnRH secretion,<sup>55</sup> is associated with a decrease in hypothalamic KISS1 mRNA levels.<sup>56</sup> The observation suggests that

kisspeptin neurons play an important role in the negative feedback loop that regulates LH secretion in the male, which also involves opioid and GABA neuronal input.<sup>57</sup> Gonadal steroids also suppress hypothalamic KISS1 expression in females. In postmenopausal women and ovariectomized monkeys, the density of neurons expressing KISS1 mRNA is significantly higher than in premenopausal women and in intact female monkeys, and treatment with estrogen and progesterone markedly decreases KISS1 expression,<sup>46</sup> suggesting that kisspeptin neurons also participate in mediating the hypothalamic negative feedback actions of ovarian steroid hormones. **The collective body of evidence thus indicates that kisspeptin neurons are a critical component of the neurobiologic mechanism that regulates the activity of the hypothalamic pulse generator.**

In some way, the system that controls the ontogeny of pulsatile GnRH secretion integrates kisspeptin signaling with that of other neurotransmitters (glutamate, GABA) and neuropeptides (NPY). Whether kisspeptin neurons in the arcuate nucleus function by tracking growth as a “pubertal clock” or simply relay information from such centers to the GnRH neuronal network is unknown.<sup>58</sup> Regardless, kisspeptin neurons have emerged as one of the primary transducers of the internal and external environmental cues that regulate the neuroendocrine reproductive axis.

## Peripheral Signaling

The age at onset of puberty has been declining steadily as the prevalence of obesity has been increasing, suggesting that a critical body weight<sup>59</sup> or body composition<sup>60</sup> may be an important factor in determining the timing and progression of puberty.<sup>61</sup> Conversely, the suppressive effects of fasting<sup>62,63</sup> and chronic malnutrition<sup>64</sup> on the neuroendocrine control of reproduction are well known and consistent with the hypothesis. The manner in which such metabolic signals might be communicated and integrated with the reproductive axis in primates is unknown, but studies in ungulates suggest an effect on pulsatile hypothalamic GnRH secretion.<sup>65</sup>

## Leptin

Leptin is produced by adipocytes and serum concentrations are strongly associated with body fat and changes in body fat content. Not surprisingly, leptin has been implicated as one way in which metabolic signals might be communicated to the higher centers controlling the activity of the hypothalamic pulse generator at the onset of puberty.

Leptin-deficient mice and rats fail to enter puberty, and treatment with leptin induces the onset of puberty.<sup>66</sup> Studies in transgenic mice in which the leptin receptor (LEPR) has been knocked out of GABAergic and glutamatergic neurons via Cre/Lox

recombination showed decreased fecundity in mice with changes in GABAergic neurons, but not in glutamatergic neurons. Furthermore, this influence on GABA signaling affects the onset of puberty, as well as the regulation of fertility throughout adult life.<sup>67,68</sup>

In humans, serum leptin concentrations in boys and girls diverge at puberty. In males, leptin levels first increase and then decrease again to prepubertal concentrations, whereas in females leptin concentrations rise throughout puberty.<sup>69,70</sup> One study found that serum leptin levels were directly related to the amount of subcutaneous fat and inversely related to androgen levels.<sup>71</sup> Another in girls observed that an increase in the mean serum leptin concentration to 12.2 ng/mL, corresponding to 29.7% body fat and a body mass index (BMI) of 22.3, was associated with a decrease in age at menarche and that a 1 ng/mL increase in serum leptin lowered the age at menarche by 1 month.<sup>72</sup>

Evidence from studies in children with congenital leptin deficiency has provided insights into the potential importance of leptin as a somatic stimulus for the onset of puberty. In affected pubertal age children, treatment with recombinant leptin has been associated with endocrine changes consistent with the onset of puberty, whereas all adults with congenital leptin or LEPR deficiency described have had severe hypogonadotropic hypogonadism.<sup>73</sup> However, similar treatment in younger children has not induced premature puberty.<sup>74</sup> These clinical observations suggest that leptin plays an important, but only permissive, role in the onset of puberty. Nonetheless, they are consistent with the idea that a circulating somatic hormone might have the ability to influence or modulate the activity of the hypothalamic GnRH pulse generator.<sup>17</sup>

## **Other Candidate Metabolic Signals**

Numerous other metabolic signals have been suggested as playing a role in the nutritional regulation of reproduction, such as insulin, ghrelin (the endogenous ligand of the growth hormone [GH] secretagogue with a putative role in energy balance),<sup>75</sup> galanin-like peptide (a potential neuronal target of leptin),<sup>76</sup> and free fatty acids.<sup>77</sup> Recent work has suggested that ghrelin suppresses kisspeptin secretion in the arcuate nucleus and anteroventral periventricular area. Neuropeptide Y and pro-opiomelanocortin (POMC) may also have a role in kisspeptin secretion (the role of these hormones in feeding behavior is discussed in [Chapter 19](#)).<sup>78</sup> However, the manner in which these signals might interact with inhibitory and excitatory hypothalamic neurotransmitters and peptides and any role they may have in the onset of puberty remain to be established.

# THE PHYSIOLOGY OF NORMAL PUBERTY

---

Although the timing, sequence, and pace of pubertal maturation vary among individuals, the sentinel events of puberty generally follow a predictable pattern. **Adrenarche** describes the activation of adrenal androgen secretion that begins before puberty and ultimately stimulates **pubarche**, the appearance of pubic hair. **Gonadarche** describes the activation of the hypothalamic-pituitary-gonadal axis, which facilitates the pubertal growth spurt and stimulates **thelarche**, the appearance of breast tissue, and finally **menarche**, the onset of menses.



# Adrenarche

Adrenarche is the term used to describe the increase in adrenal androgen production that begins at approximately 6 years of age in both boys and girls.<sup>79,80</sup> **Although adrenarche is independent of the maturation of the hypothalamic-pituitary-gonadal axis, the two often are temporally related.**<sup>81</sup> The increase in adrenal androgen production results from a change in the adrenal response to adrenocorticotrophic hormone (ACTH) stimulation, characterized by a shift toward increased production of  $\Delta^5$ -3 $\beta$ -hydroxysteroid intermediates (17-hydroxypregnenolone; dehydroepiandrosterone, DHEA) and decreased production of  $\Delta^4$ -ketosteroids (17 $\alpha$ -hydroxyprogesterone, 17-OHP; androstenedione), with no change in cortisol secretion.<sup>82</sup> Consequently, an increase in serum DHEA sulfate (DHEA-S) levels heralds the onset of adrenarche. **Generally, the best indicator of adrenarche is a serum DHEA-S concentration greater than 40  $\mu\text{g}/\text{dL}$ , which is higher than that normally seen in children 1–5 years of age (5–35  $\mu\text{g}/\text{dL}$ ).**

Adrenal androgens derive from the zona reticularis, the innermost layer of the adrenal cortex,<sup>83</sup> which begins to form at approximately 3 years of age and becomes well defined coincident with the increase in DHEA-S production at adrenarche. The molecular mechanisms that govern adrenal cortical differentiation involve a variety of different genes, but little is known about their transcriptional regulation.<sup>84</sup> The zona reticularis exhibits a unique enzymatic profile. The activity of 3-hydroxysteroid dehydrogenase/  $\Delta^5$ - $\Delta^4$  isomerase (3 $\beta$ -HSD), which catalyzes the oxidation and isomerization of  $\Delta^5$ -3 $\beta$ -hydroxysteroid precursors into  $\Delta^4$ -ketosteroids, is low.<sup>85</sup> In contrast, the activities of P450c17, including both 17 $\alpha$ -hydroxylase (catalyzing the conversion of pregnenolone to 17-hydroxypregnenolone) and 17,20 lyase (catalyzing the conversion of 17-hydroxypregnenolone to DHEA), are high, as is steroid sulfotransferase activity.<sup>86</sup> Cytochrome b5, which facilitates 17,20 lyase activity, also is preferentially expressed.<sup>87</sup> Taken together, the enzyme profile of the zona reticularis favors the formation of DHEA and DHEA-S.

**The primary stimulus for adrenarche is unknown.** Although ACTH is an obvious candidate, circulating levels of adrenal androgens change without any corresponding changes in ACTH or cortisol during fetal life, puberty, and with aging. In other conditions such as chronic disease, surgical stress, recovery from secondary adrenal insufficiency, and anorexia nervosa, changes in ACTH-induced cortisol secretion are not accompanied by any change in serum adrenal androgen concentrations.<sup>88</sup> Although derivatives of POMC (produced by pituitary corticotropes)<sup>89</sup> and other pituitary-dependent factors have been implicated,<sup>90</sup> conclusive evidence for an adrenal androgen-

stimulating hormone is lacking.<sup>91,92</sup> Whatever the stimulus might be, it might act to spur the growth and differentiation of the zona reticularis, which may derive from cells originally contained within the “fetal zone” of the adrenal cortex having a unique enzymatic profile (described above). Alternatively, it might act by suppressing 3 $\beta$ -HSD<sup>85</sup> or by stimulating the 17,20 lyase activity of P450c17.<sup>86</sup> Interleukin-6 has been implicated as a mediator because it is highly expressed in the zona reticularis and can stimulate DHEA secretion.<sup>93</sup> Leptin also has been implicated, because adrenarche coincides with the preadolescent increase in body fat<sup>94</sup> and leptin levels<sup>95</sup> and leptin stimulates 17,20 lyase activity.<sup>96</sup> However, the temporal linkage between adrenarche and increasing body fat also might result from a compensatory hyperinsulinemia or from activation of the GH/insulin-like growth factor 1 (IGF-1) axis.<sup>97</sup>

The steady increase in adrenal androgen secretion after adrenarche ultimately stimulates **pubarche**, the appearance of pubic hair, and also the development and activity of the pilosebaceous unit, consisting of a hair follicle and sebaceous gland.<sup>98</sup> Adrenal androgen levels correlate with changes in bone density, suggesting they also may contribute to growth in cortical bone.<sup>99</sup> If adrenarche has any more fundamental role in the onset of puberty, the mechanism is unknown. **Adrenarche generally precedes activation of the hypothalamic-pituitary-gonadal axis, or gonadarche, by approximately 2–3 years.** The temporal relationship suggests that adrenal androgen secretion might stimulate the pubertal transition, but several lines of evidence indicate otherwise. First, premature adrenarche generally is not associated with an earlier onset of thelarche or menarche. Second, adrenarche occurs in those with congenital hypergonadotropic hypogonadism (e.g., gonadal dysgenesis) or hypogonadotropic hypogonadism (e.g., Kallmann syndrome). Third, gonadarche occurs in children with Addison disease (hypoadrenalism) treated with glucocorticoids. Finally, in children under age 6 with true precocious puberty, gonadarche precedes adrenarche.

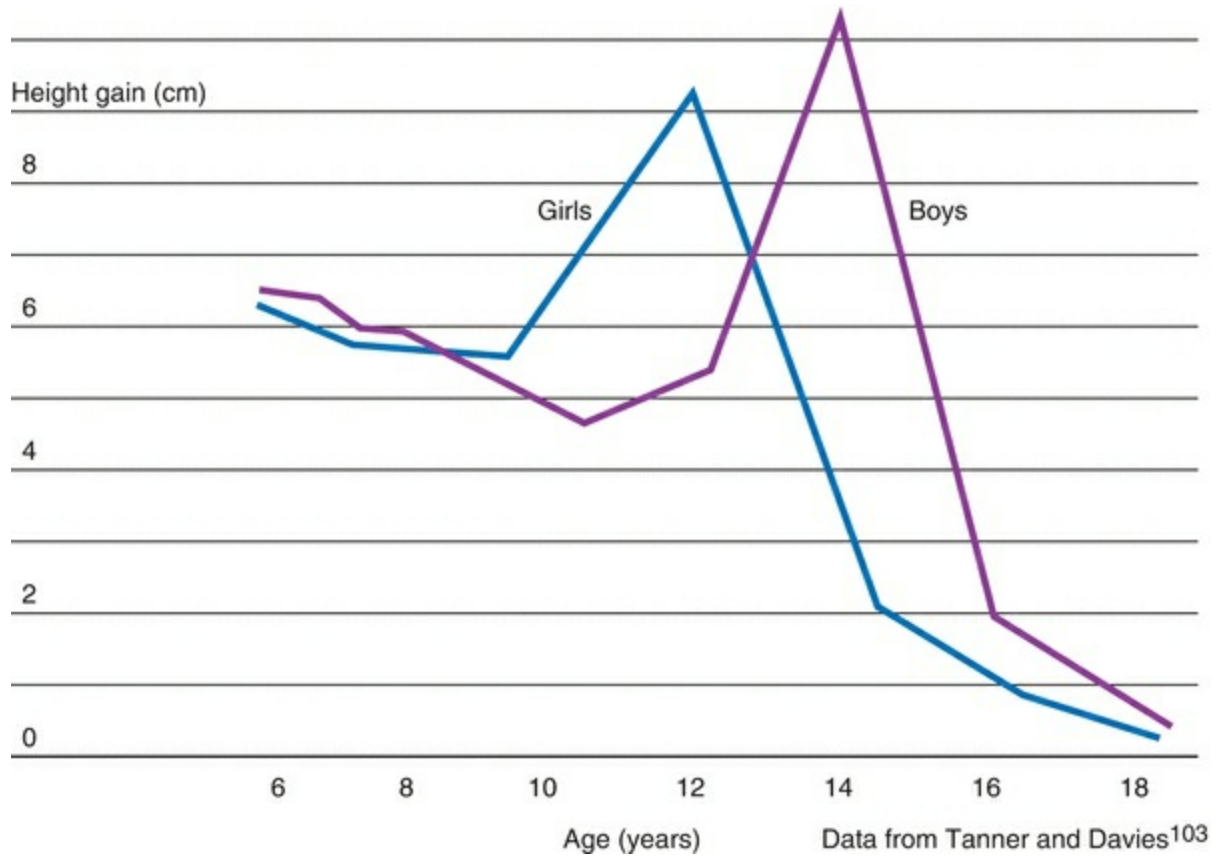
# Growth

**A substantial proportion of adult height, about 17–18%, is gained during puberty.<sup>100</sup>** Growth of the limbs precedes that of the trunk, beginning in the distal portions and later also involving the proximal part of the limbs; growth of the trunk occurs primarily during later puberty.<sup>101</sup> **The pubertal growth spurt occurs approximately 2 years earlier in girls than in boys, and, in general, peak height velocity is reached approximately 6 months before menarche.<sup>102</sup>**

The difference in adult height of men and women relates to the onset and time of the growth spurt in boys and girls. Boys are approximately 2 cm taller than girls when girls reach their peak height velocity, grow 3–4 cm/year for another 1–2 years before entering puberty, and reach a greater peak height velocity (9.3 cm/year) than girls (9.0 cm/year).<sup>103</sup>

**Bone mass accumulation during puberty is critical to the development of peak bone mass, which is a major determinant of the risk for developing osteoporosis in later life.** Although genetics may be the most important determinant of peak bone mass, other factors such as nutrition and hormone exposure during puberty also contribute. About one-half of total body calcium is accrued during puberty in females and one-half to two-thirds in males.<sup>104,105</sup> **In girls, the peak velocity in bone mineral accretion occurs at menarche, approximately 9–12 months after peak height velocity is attained.<sup>106,107</sup>** The pubertal increase in bone density is greater in black females than in white females.<sup>108</sup> Taken together, these data suggest that the window of opportunity to maximize peak bone mass is relatively narrow.<sup>105</sup>

Weight changes during pubertal maturation reflect changes in body composition and the relative proportions of lean body mass and fat. Skinfold thickness decreases in early puberty and increases after peak height velocity, particularly in girls. Adolescent girls have more body fat than boys, most being deposited in the upper arms, thighs, and back; the gender difference increases throughout puberty. The increase in BMI before 16 years of age relates primarily to changes in fat-free mass and thereafter to an increase in fat mass.<sup>109</sup> If desired, BMI can be tracked from adolescence to adulthood using published tables for comparison by age and ethnicity<sup>110</sup> (**Figure 9.2**).



**FIGURE 9.2**

# Growth Hormone

GH, produced by somatotropes, is the pituitary hormone produced in greatest abundance. The GH gene family includes five distinct genes, all of which are located on chromosome 17 (17q22).<sup>111</sup> The pituitary GH gene (GH1) encodes two alternatively spliced mRNAs, yielding a predominant 22-kDa GH molecule and another 20-kDa molecule that accounts for approximately 10% of circulating GH. Placental syncytiotrophoblasts express a GH variant in addition to three other genes encoding human chorionic somatotropin, also known as human placental lactogen (discussed in [Chapter 7](#)). The regulation of pituitary GH secretion is highly complex. GH secretion is controlled primarily by hypothalamic GH-releasing hormone (GHRH) and by peripheral factors acting on somatotropes that stimulate (e.g., ghrelin)<sup>112</sup> or inhibit (e.g., somatostatin)<sup>113</sup> GH release.<sup>114,115,116</sup> Most of the peripheral actions of GH are mediated by insulin-like growth factor I (IGF-I), which inhibits GH release. Nutritional factors also play a role in the regulation of GH secretion; whereas fasting<sup>117</sup> and high-protein meals<sup>118</sup> stimulate GH release, hyperglycemia and leptin inhibit GH secretion.<sup>119</sup> Estrogens stimulate, and excess glucocorticoids inhibit GH release. **GH secretion peaks during puberty and declines with age, by approximately 50% every 7 years.**<sup>117</sup>

Like the gonadotropins, GH is secreted in a pulsatile fashion, and at the onset of puberty, GH pulse amplitude increases, especially during sleep.<sup>120</sup> Consequently, GH concentrations rise progressively. **The rate of the increase in circulating GH levels is the most important determinant of the pubertal growth rate; slower-growing children exhibit fewer and lower-amplitude GH pulses and a more gradual increase in serum GH concentrations.**<sup>121</sup>

GH acts via binding to a specific receptor to stimulate hepatic synthesis and secretion of IGF-I, which promotes both growth and differentiation.<sup>111</sup> GH receptor mutations result in GH insensitivity and growth failure (Laron dwarfism);<sup>122</sup> in affected individuals, serum GH concentrations are elevated and levels of IGF-I are low. GH stimulates growth via direct and indirect (via IGF-I) actions on the epiphyseal plates of long bones. GH also has a number of metabolic actions, which include increased lipolysis, stimulation of protein synthesis, insulin antagonism, and water and sodium retention.

## Insulin-Like Growth Factor I

IGF-I is synthesized and secreted by the liver in response to GH stimulation and circulates in serum bound to high-affinity IGF-binding proteins (IGFBPs). The genes

encoding IGF-I, IGF-II, and insulin all belong to the same family. The IGF1 gene has several components and yields several different mRNAs, including the 6 kb form that is regulated by GH. IGF-I acts via its own receptor, which is widely distributed in a variety of tissues and organs.<sup>123</sup> IGF-I receptor concentrations are controlled by GH, thyroxine, and other growth factors such as fibroblast growth factor and platelet-derived growth factor. IGF-I acts via a complex signaling cascade to stimulate cell growth and to inhibit apoptosis.

The family of IGFBPs includes six proteins having greater affinities for IGF-I than the IGF-I receptor. IGFBPs are present in all extracellular fluids and serve both to transport IGF-I and to control the amount of IGF-I available to bind to the IGF-I receptor. IGFBP-3 is the most abundant in serum and has the highest affinity for IGF-I, but generally is saturated. Although present in lower concentrations, IGFBP-1 is unsaturated and therefore has greater impact on the levels of free IGF-I. The serum IGFBP-1 concentration is regulated by insulin, increasing during fasting when insulin levels are low and decreasing after feeding or administration of insulin.<sup>124</sup> IGF-I levels are decreased in diseases associated with malnutrition such as inflammatory bowel disease and in hypothyroidism. IGF-I augments the effects of FSH and LH in the ovary, the effect of ACTH on adrenal steroidogenesis, and the thyroid response to thyroid-stimulating hormone (TSH). **IGF-I levels rise sevenfold from very low concentrations at birth to peak values at puberty, fall rapidly by approximately 50% by age 20, and then decline slowly with advancing age.**<sup>125</sup>

## Gonadal Steroids

The pubertal growth spurt is stimulated primarily by rising levels of GH and IGF-I, but a substantial body of evidence indicates that sex steroids also play an important role. In children with central (gonadotropin-dependent) precocious puberty treated with a long-acting GnRH agonist, mean height velocity and nocturnal serum GH and IGF-I levels, initially above the means for chronologic age, decrease significantly after 6–12 months and remain suppressed for the duration of treatment.<sup>126,127</sup> A study in children with central precocious puberty and GH deficiency (due to an intracranial lesion) observed that bone age was advanced in GH-deficient subjects, but not as much as in control subjects with precocious puberty and normal GH secretion; IGF-I levels were lower in GH-deficient subjects, but greater than in age-matched prepubertal GH-deficient children.<sup>128</sup> In a subset of GH-deficient subjects, treatment with a GnRH analog suppressed gonadal sex steroid levels and decreased height velocity, with no appreciable change in GH or IGF-I levels. In girls with Turner syndrome, treatment with exogenous estrogen increases growth velocity and bone age, compared to those observed in placebo-treated controls.<sup>129,130</sup> **Taken together, these observations**

**indicate that the pubertal growth spurt is mediated, at least in part, by a sex steroid-induced increase in GH secretion. Moreover, they demonstrate that precocious puberty can induce a substantial growth spurt, even in the absence of a normal pubertal increase in circulating GH or IGF-I. However, normal pubertal growth requires the combined actions of sex steroids and GH. Ultimately, sex steroids limit adult height by stimulating epiphyseal fusion.**

# The Timing of Puberty

What triggers the onset of puberty remains one of the most compelling unanswered questions in reproductive endocrinology. The age at onset of puberty and menarche is influenced by genetics, overall health, social environment, and environmental exposures.

An analysis of two genome-wide association studies including more than 17,000 women from the Nurses' Health Study and the Women's Genome Health Study identified 10 common variants or single nucleotide polymorphisms (SNPs) clustered in the regions of chromosomes 6q21 and 9q31.2 that were associated with age at menarche.<sup>131,132</sup> Genetic variation in or near the locus (6q21) of the LIN28B gene (encoding a developmentally regulated RNA binding protein)<sup>133</sup> has been associated with age at menarche in a number of human populations.<sup>132,134,135</sup> Some genetic variants associated with adult height also have been associated with age at menarche, suggesting the association between height and age at menarche has a genetic basis.<sup>132,134</sup> Other genes associated with age at menarche include FTO (fat mass and obesity-associated gene) and NEGR1 (neuronal growth regulator 1), both of which also are associated with childhood obesity.<sup>134</sup> Children with a family history of early puberty are more likely to experience an early puberty themselves; age at menarche correlates relatively well between mothers and daughters and between sisters.<sup>136</sup>

Children who live closer to the equator, at lower altitudes, and in urban areas and mildly obese children generally begin puberty earlier than those who live in northern latitudes, at higher elevations, and in rural areas and those of normal weight. Accumulating evidence suggests that certain environmental toxicants acting as “endocrine disruptors” also may influence the timing of sexual development.<sup>137</sup>

The age at onset of puberty has been declining gradually in the general population of the United States over the past century. Although the rate of decrease has slowed considerably more recently, the trend has continued. Overall, the average age at menarche for American girls decreased from approximately 12.75 years in the 1960s to approximately 12.5 years in the early 1990s.<sup>138,139</sup> A 1997 study conducted by the Pediatric Research in Office Settings (PROS) network examined the timing of pubertal development in more than 17,000 American girls (90% white, 10% black) and found that the earliest signs of puberty were occurring at ages significantly younger than in the past, with striking racial differences, as follows<sup>140</sup> (Table 9.1).

**TABLE 9.1 Age-based Pubertal Milestone Data from the 1997 PROS Network Study. Note the Differences between**

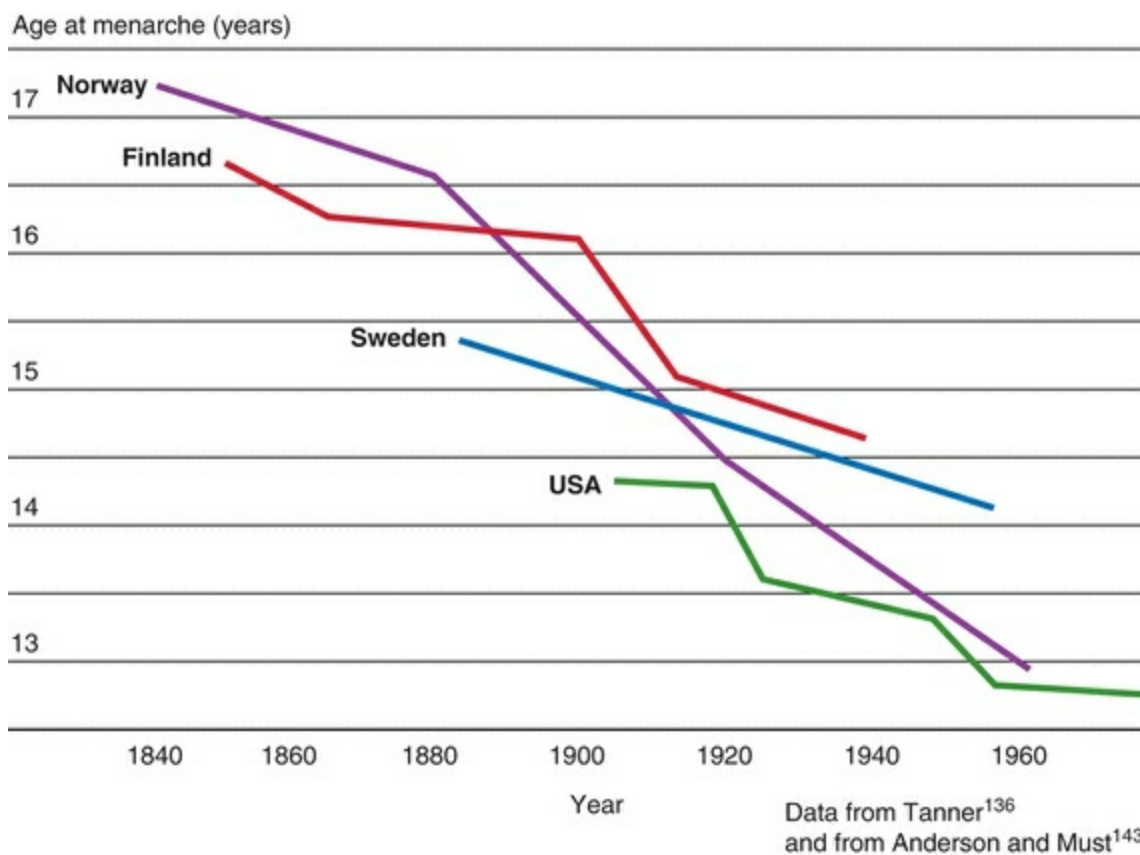


# **Caucasian and Black girls with the Latter Achieving Thelarche, Pubarche, Adrenarche**

<b>Pubertal Milestone</b>	<b>Black American Girls</b>	<b>White American Girls</b>
<b>Thelarche</b>		
Mean age	8.9 y	9.0 y
Age 6	6.4%	2.9%
Age 7	15.4%	5.0%
Age 8	37.8%	9.5%
Age 9	62.6%	32.1%
Age 10	80.2%	61.5%
Age 11	96.0%	85.4%
Age 12	98.9%	96.0%
<b>Pubarche</b>		
Mean age	8.8 y	9.5 y
Age 6	9.5%	1.4%
Age 7	17.7%	2.8%
Age 8	34.3%	7.7%
Age 9	62.6%	20.0%
Age 10	85.6%	46.4%
Age 11	95.2%	74.3%
Age 12	98.9%	92.2%
<b>Thelarche and/or pubarche</b>		
Age 6	14.3%	3.7%
Age 7	27.2%	6.7%
Age 8	48.3%	14.7%
Age 9	77.4%	38.2%
Age 10	94.6%	67.9%
Age 11	98.4%	88.0%
Age 12	100.0%	96.6%
<b>Menarche</b>		
Mean age	12.2 y	12.9 y
Age 9	2.7%	0.2%
Age 10	6.3%	1.8%
Age 11	27.9%	13.4%
Age 12	62.1%	35.2%

These data indicate that a substantial proportion of American girls begin pubertal development 6–12 months earlier than previously observed. **On average, black American girls begin puberty between ages 8 and 9 and white American girls by age 9. However, thelarche and/or pubarche can occur normally in black girls as early as age 6 and in white girls as early as age 7.**

Subsequent studies analyzing data from the National Health and Nutrition Examination Survey (NHANES) have observed a 2.3-month decrease in the average age of menarche between surveys for the years 1988–1994 (12.53 years) and 1999–2002 (12.34 years) and an overall 4.9-month decrease since 1960.<sup>138,141,142,143</sup> The decrease in age of menarche has been observed in all ethnic groups, declining from 12.57 to 12.52 years in non-Hispanic White girls, from 12.09 to 12.06 years for non-Hispanic Black girls, and from 12.24 to 12.09 for Hispanic American girls.<sup>143</sup> Changes in the population distribution of race and ethnicity over time explain the larger change in overall average age compared to those within groups (**Figure 9.3**).



**FIGURE 9.3**

Historically, the trend to an earlier onset of sexual development has been attributed to improved nutrition and less stressful living conditions.<sup>144</sup> The age at menarche has declined as the prevalence of obesity has increased, suggesting that a critical body weight<sup>59</sup> or body composition<sup>60</sup> is an important factor in determining the onset and progression of puberty.<sup>61</sup> **Indeed, higher weight and body fat mass are associated with an increased likelihood of early menarche.**<sup>61,138,145,146,147</sup> Data from the U.S. NHANES survey indicated that a girl with a BMI at the 85th percentile is more than twice as likely to have reached menarche as a girl of the same age and race/ethnicity having a BMI at the 50th percentile.<sup>143</sup> However, girls reach menarche over a wide range of weight and BMI, and age at menarche cannot be predicted reliably for individuals on that basis.<sup>148</sup> **Importantly, early pubertal development is associated with slightly decreased adult height and an increased risk for obesity, compared to a late menarche**<sup>149,150,151</sup> (Table 9.2).

## **TABLE 9.2 Average Ages of Pubertal Milestones in Different Populations**

Country	Year(s)	Subjects	Ages	Thelarche	Pubarche	Menarche
Chile	2000	758	6–16	8.9	9.4	12.7
China	1993	3,749	7–19	9.8	11.6	12.4
Denmark	1991–1993	1,100	6–20	9.9	11.3	13.4
Egypt	2000	1,550	6–18	9.7	9.5	12.4
England	1960–1970	192	3–19	11.2	11.7	13.5
India	1988–1991	9,951	5–18	9.2	—	12.6
Iran	2003–2004	1,420	6–17	9.7	9.5	12.7
Italy	1998–2001	1,642	6–15	9.5	9.6	11.9
Japan	1990–2000	832	6–14	9.7	—	12.2
Korea	1993–1995	4,237	14–20	—	—	12.5
Lithuania	1999–2000	1,231	7–12	—	9.2	11.7
Netherlands	1996–1997	3,028	8–20	9.7	11.0	12.9
Spain	2000	266	8–10	9.7	—	12.4
Thailand	1997–1999	300	9–19	9.4	11.1	11.2
Turkey	2005	1,562	6–16	9.2	9.6	12.4
United States	1992–1993	15,439 White	3–12	9.9	9.5	12.9
		1,638 Black		8.9	8.8	12.2

From Ma HM, Du ML, Luo XP, Chen SK, Liu L, Chen RM, Zhu C, Xiong F, Li T, Wang W, Liu GL, Onset of breast and pubic hair development and menses in urban Chinese girls, *Pediatrics* 124:e269, 2009.

# Stages of Pubertal Development

Puberty includes a series of predictable events that vary in timing, sequence, and pace. **In general, the first sign of puberty in most adolescent girls is an acceleration of growth, followed by breast budding (thelarche), the appearance of pubic hair (pubarche), and, finally, the onset of menses (menarche).**

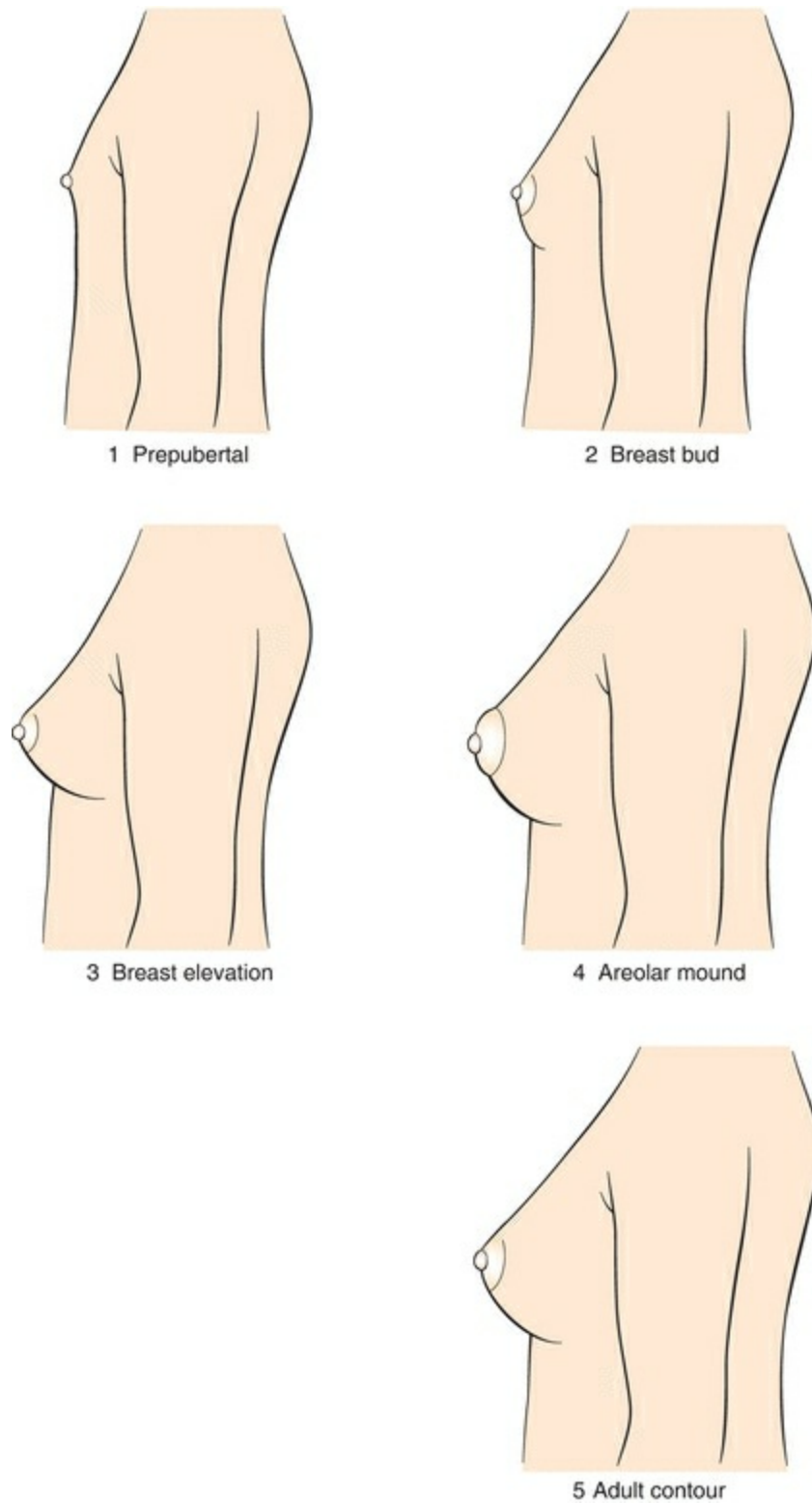
The staging systems used most frequently to describe the physical changes of puberty were first described by Marshall and Tanner in 1969 (girls)<sup>152</sup> and 1970 (boys).<sup>153</sup> The Tanner stages describe secondary sexual characteristics, including breast development in girls, pubic hair growth in both sexes, and genital development in boys. As shown in the diagrams, there are five Tanner stages of breast and pubic hair development in girls, with stage 1 representing the prepubertal state and stage 5 representing adult development.

Breast development follows a recognized sequence of events. Breast budding (Tanner stage 2) is distinguished by enlargement and by widening of the areolae. The breast then enlarges, becoming elevated beyond the areolae (Tanner stage 3). The breast enlarges further and the areolae and nipple form secondary mounds (Tanner stage 4), just before the breast achieves an adult contour (Tanner stage 5).

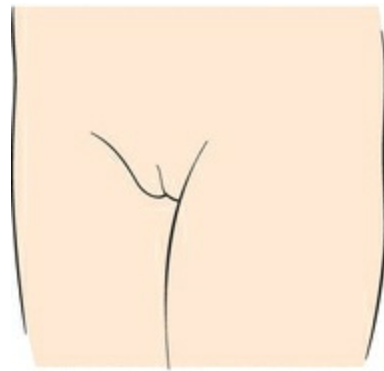
In the majority of adolescents, pubarche closely follows thelarche, but in a substantial minority, the sequence is reversed and pubarche precedes thelarche. In either case, the two are closely linked and progress in parallel. Pubarche (Tanner stage 2) is distinguished by the emergence of a small amount of long, relatively straight hair on the labia majora. The hair then becomes curly and coarser and extends outward (Tanner stage 3). The hair extends further to cover the labia (Tanner stage 4) before assuming an adult pattern with extension onto the medial thigh (Tanner stage 5).

**Menarche occurs an average of 2.6 years after the onset of puberty and after the peak of growth has passed.**<sup>102, 106, 152</sup> **On average, the pubertal sequence of accelerated growth, thelarche, pubarche, and menarche requires a period of 4.5 years (range, 1–6 years).** The relationship between menarche and the growth spurt is relatively fixed. After menarche, growth slows and generally does not increase more than about 6 cm (2.4 inches). The menses immediately following menarche usually are anovulatory, irregular, and occasionally heavy. Anovulatory cycles frequently persist for as much as 12–18 months and are not (**Figures 9.4 and 9.5**) uncommon even up to 4 years after menarche.<sup>154, 155</sup> However, the frequency of menses generally increases rapidly over the first year after menarche; 65% of adolescent girls report having 10 or more periods per year at the end of the first postmenarcheal year and 90% after 3 years.<sup>30</sup> The hallmark of the maturation of the hypothalamic-pituitary-ovarian axis and of the completion of puberty is the development of estrogen positive feedback, which

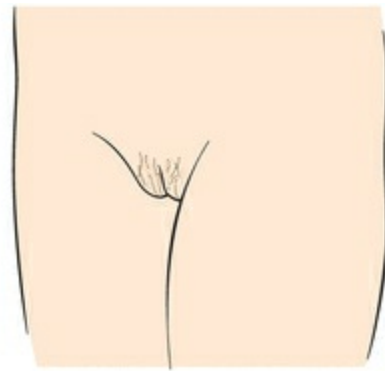
stimulates the midcycle LH surge and ovulation. In general, ovulatory cycles become progressively more frequent. The time required to establish ovulatory cycles relates to the age at menarche; when menarche occurs after the age of 13, only one-half have ovulatory cycles within 4.5 years<sup>156</sup> (Figure 9.6).



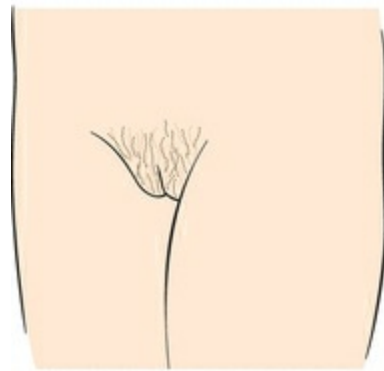
**FIGURE 9.4**



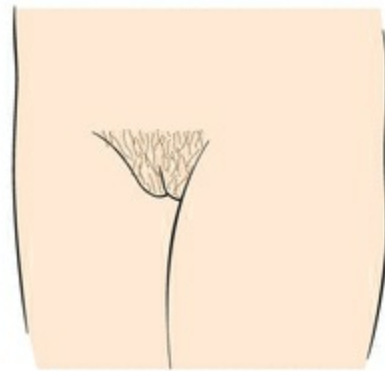
1 Prepubertal



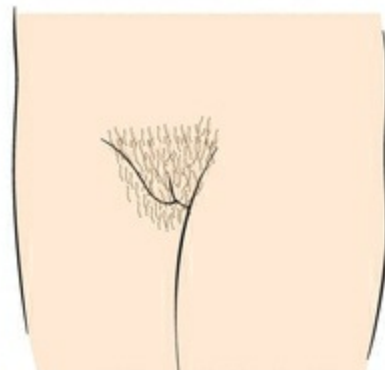
2 Presexual hair



3 Sexual hair



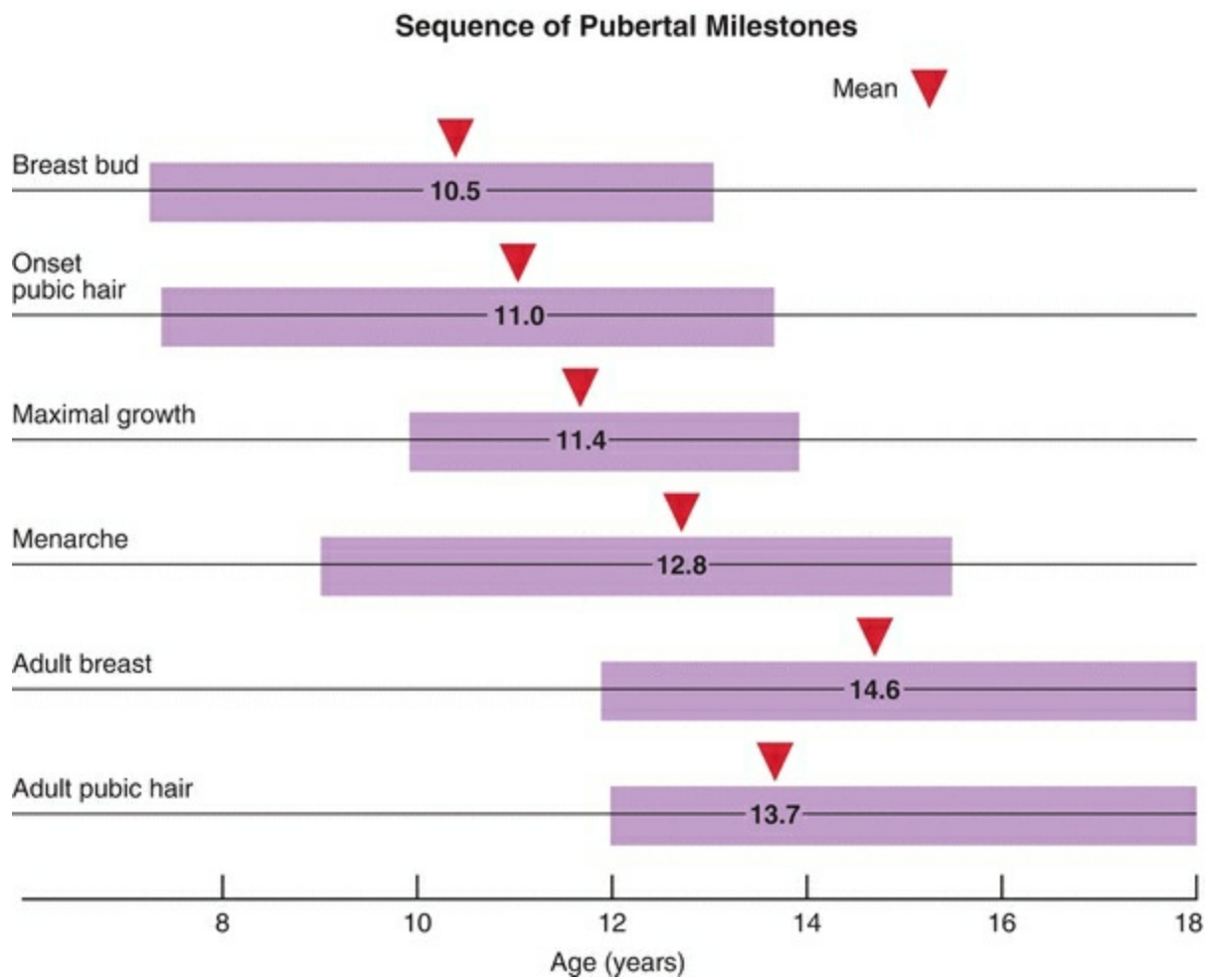
4 Mid-escutcheon



5 Female escutcheon

**FIGURE 9.5**





**FIGURE 9.6**

# Summary of Pubertal Events

The onset of puberty is an evolving sequence of maturational steps. The hypothalamic-pituitary-gonadal axis differentiates and develops during fetal life and becomes fully functional before birth. Beginning in late infancy and continuing through childhood, the axis is inactive because pulsatile secretion of hypothalamic GnRH is suppressed to very low levels of activity by central inhibitory mechanisms and, to a lesser extent, by a high sensitivity to low levels of gonadal steroid feedback.

In late childhood, adrenal androgen production increases (adrenarche), in response to an unknown stimulus, rises steadily thereafter, and ultimately stimulates the growth of pubic and axillary hair (pubarche). After a decade of quiescence, pulsatile GnRH secretion increases and the hypothalamic-pituitary-gonadal axis is reactivated (gonadarche), probably in response to metabolic signals from the periphery. FSH and LH levels rise moderately before age 10, followed by a gradual increase in estradiol concentrations, which stimulates breast development (thelarche). The increase in pulsatile gonadotropin secretion occurs first at night, during sleep, but gradually extends throughout the day.

The rapid increase in skeletal growth (the pubertal growth spurt) that precedes thelarche and pubarche is mediated primarily by a sex steroid-induced increase in GH secretion, which, in turn, stimulates increased production of IGF-I, and, to a lesser extent, by the direct effects of increasing sex steroid concentrations. Ultimately, rising sex steroid levels limit adult height by stimulating epiphyseal fusion.

At midpuberty, gonadal estrogen production increases sufficiently to stimulate endometrial proliferation, ultimately resulting in the onset of menses (menarche). Postmenarcheal cycles are at first anovulatory. Gradually, as the estrogen positive feedback mechanism matures, ovulatory cycles increase in frequency and, in late puberty, become established (Table 9.3).

## TABLE 9.3 Serum Hormone Concentrations During Female Puberty<sup>157,158,159,160,161,162,163</sup>

<b>Tanner Stage</b>	<b>FSH (IU/L)</b>	<b>LH (IU/L)</b>	<b>Estradiol (pg/mL)</b>	<b>DHEA-S (ng/dL)</b>
Stage 1	0.9–5.1	1.8–9.2	<0.8	19–302
Stage 2	1.4–7.0	2.0–16.6	7–37	45–1,904
Stage 3	2.4–7.7	5.6–13.6	9–59	125–1,730
Stage 4	1.5–11.2	7.0–14.4	10–156	153–1,321
Adult follicular	3.0–20.0	5.0–25.0	30–100	162–1,620

# COMMON PROBLEMS ASSOCIATED WITH PUBERTY

---

Some of the common physical manifestations of pubertal maturation may be viewed by patients or their parents as abnormal, including anemia, acne, psychosocial problems, myopia, and dysfunctional uterine bleeding. Adolescents also are at high risk for sexually transmitted infections (STIs).

Girls tend to eat less of foods high in iron content, such as meat, and a low heme iron intake increases the risk of low iron stores.<sup>164</sup> The third NHANES (1988–1994) observed a 9% prevalence of anemia among American girls between the ages of 12 and 15 years.<sup>165</sup>

Acne is a disorder of the pilosebaceous unit caused by androgen stimulation characterized by follicular occlusion and inflammation. During puberty, the number of acneiform lesions increases, at all stages.<sup>166</sup> In girls, acne tends to be more severe in the late stages of puberty, which are associated with higher serum concentrations of DHEA-S.<sup>167</sup>

The psychosocial changes during puberty predispose to an increased incidence of depression, which is twice as common in girls as in boys.<sup>168</sup> Many girls become unhappy with their physical appearance, resulting in a decrease in self-esteem that is more common in white girls than in black girls.<sup>169</sup> The problem is most common when pubertal development is not synchronous with that of peers.<sup>170</sup> Early-maturing girls are more likely to develop psychopathology,<sup>171</sup> to have older friends,<sup>172</sup> and to be vulnerable to peer pressures.<sup>173</sup>

The prevalence of myopia (nearsightedness), caused by growth in the axial diameter of the eye, is greatest during puberty. Dysfunctional uterine bleeding is a consequence of anovulatory cycles and is common in adolescent girls during the 1st year or 2 after menarche.

Adolescents represent the highest-risk age group for nearly all STIs.<sup>174</sup> The risk for acquiring an STI relates to age at first intercourse, the number of partners, the perceived risk, and attitudes about acquiring an STI.<sup>175</sup> The persistence of a columnar epithelium on the exocervix (ectropion) also may predispose to infection with Chlamydia<sup>176</sup> and human papillomavirus.<sup>177,178</sup>

# **PRECOCIOUS PUBERTY**

---

Precocious puberty describes pubertal development that begins at an earlier age than expected, based on established normal standards. Its causes are many, ranging from variants of normal development, such as premature adrenarche, to serious pathology, including malignant intracranial neoplasms. Children with precocious puberty warrant careful evaluation to define the cause and, when indicated, prompt treatment to avoid the psychosocial and growth consequences of abnormally early sexual development.

# Indications for Evaluation

Abnormally early or precocious puberty generally is defined as pubertal development occurring more than 2.5 standard deviations earlier than the average age. Traditionally, using 10 years as the average age of onset of puberty in girls, precocious puberty has been defined as secondary sexual development before the age of 8 years. However, as discussed in an earlier section of this chapter,<sup>138,139</sup> the age at onset of puberty has been declining over the past few decades, raising questions about when pubertal development should be considered precocious and warrants clinical evaluation.

The 1997 study conducted by the PROS network observed that 6.7% of American white girls and 27.2% of black girls had breast or pubic hair development before the age of 8 years.<sup>140</sup> These observations suggested that continued application of the traditional definition of precocious puberty would result in a large number of potentially normal girls having extensive, costly, and unnecessary testing. Consequently, new guidelines were proposed, lowering the age at which evaluation is indicated to age 7 in white girls and age 6 in black girls,<sup>179</sup> sparking a vigorous debate.

Some authorities questioned the new recommendations because the PROS study population was not a random sample drawn from the general population, because the study focused on premature thelarche and premature adrenarche and not on “true” precocious puberty (typically characterized by early breast and pubic hair development), and because no cause was determined in those having precocious puberty. Criticism centered on concerns that the recommended lower ages in the newly proposed guidelines might increase significantly the risk for underdiagnosis of important endocrine pathology.<sup>180,181,182,183</sup> Indeed, a subsequent large European study involving 443 girls with central precocious puberty identified 35 with an occult intracranial lesion (8%) and reported that application of the revised American guidelines lowering the age for evaluation for precocious puberty would have missed 4/35 girls (11%) with cranial pathology.<sup>184,185</sup> Others favoring the new recommendations emphasized that fewer than 2% of girls with precocious puberty over age 6 had an intracranial lesion and that unnecessary imaging has high financial and emotional costs.<sup>186</sup>

In another American study involving 223 patients (white girls aged 7–8 years and black girls aged 6–8 years) referred to a single tertiary center solely for evaluation of precocious puberty over a 5-year period, 105 (47%) exhibited both breast and pubic hair development, 83 (37%) had only pubic hair, 24 (11%) had only breast development, and 11 (5%) had no signs of early sexual development.<sup>183</sup> Ultimately, 186/212 (88%) with signs of early puberty had a diagnosis of idiopathic gonadotropin-dependent precocious puberty and 26 (12%) had a treatable endocrinopathy amenable

to early intervention, including acanthosis nigricans/hyperinsulinemia, hypothyroidism, neurofibromatosis, GH deficiency, pituitary adenoma, McCune-Albright syndrome, and congenital adrenal hyperplasia (CAH). More importantly, more than one-third of the girls with only breast development or with breast and pubic hair development had bone ages that were advanced significantly and were, therefore, at risk for diminished growth potential.<sup>183</sup> In a more recent study from New York City, Cincinnati, and San Francisco, 10% of White, 15% of Hispanic, and 23% of Black girls between the ages of 7 and 8 years had breast development (assessed by palpation).<sup>187</sup> A subsequent guidance published by the American Academy of Pediatrics concluded that it is reasonable for primary care physicians to consider referring most girls who have a breast development before 8 years of age.<sup>188</sup> The same report emphasized that most of these girls will not have treatable endocrine pathology and will represent the lower end for a new normal.

Clearly, more and larger prospective studies are needed because questions regarding the indications for evaluation for precocious puberty remain unsettled. However, taking all of the available data into consideration, we believe that the following guidelines offer a good balance between safety and cost-effectiveness:

**All girls under the age of 6 who have either breast or pubic hair development and girls under age 8 having both breast and pubic hair development merit a thorough evaluation to determine the cause.**

**Girls under 8 years of age having only early breast development (premature thelarche) or pubic hair growth (premature adrenarche or pubarche) warrant a careful history and physical examination and, at a minimum, an evaluation of bone age and close follow-up to determine their linear growth rate in efforts to identify those who may be at risk for decreased growth potential.**

**Between the ages of 6 and 8 years, clinicians must make individual judgments regarding the extent of evaluation, based on the results of the initial evaluation and, inevitably, on the level of anxiety in the patient and her parents.<sup>9</sup>**

**Factors associated with an increased risk for intracranial pathology that clearly warrant complete evaluation and imaging include onset of puberty before age 6, rapid pubertal progression, and associated symptoms of headache, seizures, or focal neurologic deficits.<sup>179,186</sup>**

# Classification of Precocious Puberty

Traditionally, precocious puberty has been classified according to the underlying pathophysiology. However, the classification has limited practical utility in clinical practice because it reflects the final diagnosis, after evaluation is completed.

**Gonadotropin-dependent precocious puberty**, also known as “central precocious puberty” or “true precocious puberty,” describes early maturation and activation of the hypothalamic-pituitary-gonadal axis and is characterized by both breast and pubic hair development in girls and by pubic hair development and testicular enlargement (>4 mL in volume or 2.5 cm in diameter) in boys. The early developing sexual characteristics are “isosexual,” meaning they are consistent with the child’s gender.

**Gonadotropin-independent precocious puberty**, also known as “peripheral precocious puberty” or “pseudoprecocious puberty,” describes early sexual development that is independent of GnRH and gonadotropins and generally results from exposure to sex steroid hormones that derive from the gonads, the adrenals, or the environment. Gonadotropin-independent precocious puberty is further subclassified as isosexual when sexual characteristics are consistent with gender and as “contrasexual” when inconsistent with gender (virilization in girls or feminization in boys).

**Incomplete precocious puberty** describes children with isolated premature thelarche or premature adrenarche. Both usually represent variants of normal pubertal development, but some will progress to complete precocious puberty that may be gonadotropin-dependent or gonadotropin-independent.

## Gonadotropin-Dependent Precocious Puberty

Gonadotropin-dependent precocious puberty results from early maturation of the hypothalamic-pituitary-gonadal axis and is much more common in girls than in boys.<sup>189</sup> Although puberty begins earlier than normal, the sequence of pubertal events generally is normal and proceeds at the normal pace.

Up to 90% of children with gonadotropin-dependent precocious puberty have no identifiable cause (idiopathic), a diagnosis made by exclusion.<sup>190,191</sup> However, the disorder can be associated with a variety of central nervous system lesions, including tumors, irradiation, hydrocephalus, cysts, trauma, inflammatory diseases, and midline developmental defects such as septo-optic dysplasia. **Consequently, head magnetic resonance imaging (MRI) is indicated even when there are no neurologic signs or symptoms.**<sup>184,191,192</sup>

Tumors associated with gonadotropin-dependent precocious puberty include hamartomas, astrocytomas, ependymomas, pineal tumors, and optic and hypothalamic



gliomas. Hamartomas are heterotopic neuronal masses containing GnRH neurons that typically attach to the tuber cinereum or floor of the third ventricle where they can function as an ectopic hypothalamic GnRH pulse generator, divorced from the central inhibitory mechanisms that normally restrain activity during childhood; they are the most common tumor associated with precocious puberty and can be associated with gelastic seizures (laughing, giggling)<sup>193,194</sup>; some produce transforming growth factor alpha, which mediates the release of GnRH.<sup>195</sup> The precocious puberty that can be observed in children with neurofibromatosis usually relates to an optic glioma.<sup>196</sup>

As described in an earlier section of this chapter, activating mutations in the gene encoding the GPR54 receptor (KISS1R), which mediates the actions of kisspeptin (an excitatory neuroregulator of GnRH secretion), can cause gonadotropin-dependent precocious puberty.<sup>53</sup>

**Children exposed to high circulating androgen or estrogen concentrations, as may occur with CAH, virilizing tumors, and the McCune-Albright syndrome, often exhibit early maturation of the hypothalamic-pituitary-gonadal axis, which then results in gonadotropin-dependent precocious puberty.**<sup>197,198,199</sup>

Although quite rare, girls with severe primary hypothyroidism can present with precocious puberty, exhibiting breast development, galactorrhea, and episodic menstrual bleeding. In most cases, the very high serum levels of TSH, which has structural similarity to FSH, appear to activate the FSH receptor.<sup>200</sup>

Rarely, gonadotropin-dependent precocious pubertal development has resulted from an autonomous pituitary gonadotropin-secreting tumor rather than from early maturation of the hypothalamic-pituitary-gonadal axis.<sup>201,202</sup>

## **Gonadotropin-Independent Precocious Puberty**

Gonadotropin-independent precocious puberty can result from excess sex steroid secretion from the gonads or adrenals or from exposure to exogenous estrogens.

**Autonomous functional ovarian follicular cysts are the most common cause of gonadotropin-independent precocious puberty in girls.** Transient breast development and vaginal bleeding are the most common presentation, which can be an isolated event or recur at unpredictable intervals.<sup>203,204,205</sup> Serum estrogen levels typically are elevated, but not always (due to regression of the cyst), and both basal and GnRH-stimulated gonadotropin concentrations are low. In most cases, bone age is not advanced. Ovarian ultrasonography usually demonstrates one or more unilateral or bilateral ovarian cysts greater than 15 mm in diameter.<sup>206</sup> The disorder is self-limited in most and requires no treatment. However, recurrent cysts resulting in prolonged or

repeated estrogen exposure can precipitate early maturation of the hypothalamic-pituitary-gonadal axis, resulting in gonadotropin-dependent precocious puberty.<sup>204</sup> Autonomous ovarian cysts also can be an early manifestation of McCune-Albright syndrome, arising before the emergence of the characteristic skin (“café au lait spots”) or bone lesions; affected patients therefore require careful longer-term follow-up.<sup>203,205</sup>

Ovarian tumors are rare causes of gonadotropin-independent precocious puberty in girls and include granulosa cell tumors, Leydig cell tumors, and gonadoblastomas.<sup>207,208,209</sup>

**McCune-Albright syndrome is a rare disorder characterized classically by precocious puberty, café au lait skin pigmentation, and polyostotic fibrous dysplasia of the bone, all caused by a somatic mutation of the alpha subunit of the G-protein (encoded by the GNAS1 gene), which results in a mosaic distribution of cells bearing constitutively active adenylate cyclase.**<sup>210,211,212</sup> The mutation results in continuous stimulation of endocrine function and, in addition to precocious puberty, also can cause gigantism, Cushing syndrome, adrenal hyperplasia, and thyrotoxicosis, in varying combinations. Although precocious puberty is the most common clinical manifestation,<sup>213</sup> the phenotype varies with the tissues that are affected by the mutation and can include hepatitis, intestinal polyps, and cardiac arrhythmias. As in other forms of gonadotropin-independent precocious puberty, the sequence of pubertal development may be abnormal; for example, vaginal bleeding frequently precedes breast development.<sup>214</sup> The skin and bone lesions can increase over time and may not be present at the initial presentation. Early and repeated exposure to elevated sex steroid levels can result in accelerated growth, advanced bone age, and reduced adult height; it also may induce early maturation of the hypothalamic-pituitary-gonadal axis, resulting in secondary gonadotropin-dependent precocious puberty. McCune-Albright syndrome is more common in girls than in boys. The diagnosis merits consideration in girls presenting with recurrent functional ovarian follicular cysts and episodic menses.<sup>215</sup> Partial forms of the syndrome also have been described.<sup>212</sup>

Adrenal pathology, such as androgen-secreting tumors and CAH, is another cause of gonadotropin-independent precocious pubertal development.

Exposure to exogenous estrogens or environmental pollutants having estrogenic activity (xenoestrogens) can result in premature sexual development in infants or toddlers.<sup>216,217,218</sup> Examples include accidental exposure to estrogens, xenoestrogens, or placental extracts contained in cosmetics or personal hair and skin care products and environmental pollutants that can act as endocrine disruptors by mimicking estradiol, such as polychlorinated biphenyls, herbicides, pesticides, and plasticizers, which may be found in water contaminated with industrial products.<sup>219</sup> Serum hormone levels in

affected children typically are in the normal range, but can vary widely depending on the nature, time, and frequency of use or exposure. **Children are extremely sensitive to the effects of estrogen and may respond with increased growth or breast development even at serum levels below the limits of detection.**<sup>220</sup>

## **Incomplete Precocious Puberty**

Incomplete precocious puberty includes premature adrenarche or premature thelarche and usually is a variant of normal puberty. Such cases present a clinical dilemma due to uncertainty regarding whether the condition is entirely benign, as usual, or might be the first indication of true precocious puberty.

### **Premature Adrenarche**

Premature adrenarche is the most common cause of premature pubarche, describing otherwise unexplained early growth of genital hair associated with increased levels of adrenal androgens.<sup>221</sup> **Generally, the best indicator of adrenarche is a serum DHEA-S concentration greater than 40 µg/dL, which is higher than that normally seen in children 1–5 years of age (5–35 µg/dL).** In children with premature adrenarche, the growth rate and bone age often are above average but still within normal ranges. **Exaggerated adrenarche** is the term used to describe the clinical extreme of premature adrenarche, wherein the serum DHEA-S level exceeds that typical of adrenarche or for age and usually, but not always, is associated with a somewhat early onset of true puberty.<sup>222</sup>

**The cause of premature adrenarche is unknown. The condition traditionally has been considered an early variant of normal development and, as such, generally has no serious consequences. However, up to 20% of girls with premature adrenarche may subsequently develop gonadotropin-dependent precocious puberty, and close follow-up therefore is recommended.**<sup>81,223</sup> Other evidence indicates that girls with premature adrenarche also are at increased risk for developing polycystic ovary syndrome, suggesting that premature adrenarche may be an early manifestation of the disorder.<sup>224,225,226,227,228,229</sup> In many, premature pubarche is preceded by low birth weight and is followed by hyperandrogenism, hirsutism, and oligomenorrhea in adolescence, often accompanied by hyperinsulinemia and dyslipidemia. These observations suggest that insulin resistance may be the underlying metabolic disorder, causing decreased growth during fetal life, premature pubarche, and hyperandrogenism that worsens during late puberty or the early postmenarcheal years.<sup>230</sup> In those affected, metformin treatment can decrease insulin resistance and hyperandrogenism, improve the lipid profile, often restore cyclic menses, and may help to prevent later development of

diabetes and cardiovascular disease.<sup>231</sup>

Premature pubarche usually results from a premature adrenarche but also has other causes. Idiopathic premature pubarche, unassociated with any demonstrable increase in adrenal androgen production, probably reflects an increased sensitivity of hair follicles to normal androgen concentrations. In select instances, this may be caused by increased androgen receptor (AR) activity due to shorter CAG repeats or AR methylation pattern.<sup>232,233</sup> Premature pubarche sometimes can be the only clinical manifestation of a mild form of CAH.<sup>234,235</sup> Other rare causes of ACTH-dependent childhood virilization include Cushing syndrome, glucocorticoid resistance, cortisone reductase deficiency, and androgen-producing neoplasms of the adrenal gland or ovary.

The evaluation of premature pubarche should focus first on determining whether the growth of pubic hair is an isolated phenomenon or may be associated with other signs and symptoms suggesting another of the diagnoses mentioned above. **The single most important and useful test is an x-ray of the left hand and wrist for bone age. If sexual hair is small in amount and slow-growing and bone age is normal, precocious puberty is unlikely and expectant management is appropriate, with re-evaluation at 6 months and periodically thereafter.** A limited endocrine evaluation should include measurements of serum testosterone and DHEA-S, for comparison to age-adjusted normal values. The presumptive diagnosis of premature adrenarche can be made when both are appropriate for pubarche, bone age is normal, and predicted adult height is within the range expected for the family.<sup>236</sup> More extensive endocrine evaluation can be reserved for those children having other signs suggesting true precocious puberty or a virilizing disorder.

**An ACTH stimulation test to exclude the diagnosis of CAH is indicated when bone age is advanced abnormally, the predicted adult height is abnormally low, or the serum testosterone and DHEA-S concentrations are elevated above the ranges typical of premature adrenarche.** The test is performed by obtaining blood samples before and 60 minutes after administering cosyntropin (synthetic ACTH 1–24; 1 µg/m<sup>2</sup> or 0.25 mg). A stimulated serum 17-OHP concentration greater than 1,000 ng/dL generally indicates 21-hydroxylase deficiency.<sup>237</sup> In children with premature pubarche, diagnosis of the rare 3β-HSD deficiency requires a stimulated 17α-hydroxypregnenolone level greater than 9,790 ng/dL.<sup>235</sup>

Premature adrenarche is a benign condition and requires no specific treatment. Parents can be reassured that the condition is a normal variant relating to increased sensitivity of hair follicles to low levels of androgen or an early occurring incomplete form of puberty. However, children with a diagnosis of premature adrenarche merit periodic re-evaluation for evidence of progressive virilization.

## Premature Thelarche

Premature thelarche generally is defined as isolated breast development in girls before the age of 8 years. In girls, premature thelarche usually is a benign condition considered a variant of normal puberty. Early breast development is particularly common during the first year of life when the hypothalamic-pituitary-gonadal axis is still active.<sup>238,239</sup> Studies using ultrasensitive bioassays for estrogen have detected higher estrogen levels in many, but not all, girls with premature thelarche than in normal controls.<sup>240</sup> The breast also may be more sensitive to estradiol than normal in some girls.<sup>241</sup> Although most affected children subsequently experience normal puberty and growth,<sup>242,243,244</sup> a significant proportion experiences an earlier than average menarche.<sup>245</sup>

Physical examination typically reveals a light pink areola with an infantile appearance, with Tanner stage 2 or 3 breast development; frequently, the change may be unilateral or asymmetrical. There is no sign of androgen exposure.

**Exaggerated thelarche** describes those with premature thelarche who also exhibit increased growth velocity and/or advanced bone age and may represent an intermediate between premature thelarche and precocious puberty.<sup>240,246</sup> Even girls with exaggerated thelarche exhibit a prepubertal pattern of response to acute stimulation with GnRH or a GnRH agonist; FSH levels rise more than LH, which remains below 5 IU/L.<sup>247</sup> Some cases have been associated with the presence of functional ovarian cysts.<sup>203</sup> Genetic studies in girls with exaggerated thelarche have revealed that some harbor a mutation in the GNAS1 gene, suggesting that the disorder can be an early or the only sign of McCune-Albright syndrome.<sup>240,248</sup>

Premature thelarche also has been related to exposure to exogenous estrogen, including environmental chemicals that degrade slowly in the environment and can accumulate in the food chain, but no clear relationship with premature thelarche has been established.

The evaluation of premature thelarche, like that of premature adrenarche, should focus on determining whether breast development is an isolated phenomenon or associated with other signs of precocious puberty; here again, the most important initial test is an evaluation of bone age. **In children with Tanner stage 2 breast development and normal bone age, precocious puberty is unlikely and expectant management is appropriate, with re-evaluation at 6 months and periodically thereafter.**

**Approximately 15–20% of girls with premature thelarche subsequently develop gonadotropin-dependent precocious puberty, at a mean age of  $7.1 \pm 0.7$  years and a mean bone age of  $9.0 \pm 1.1$  years.**<sup>249,250</sup> A longitudinal study involving more than 150 girls with premature thelarche observed that 69% had complete regression of breast

development (13% of these later developing true precocious puberty), 21% had recurrent episodes of breast development (32% later developing true precocious puberty), and 10% had persistent breast development (57% later developing true precocious puberty).<sup>250</sup>

# Evaluation of Precocious Pubertal Development

The evaluation of early sexual development begins with a careful history and physical examination and measurement of bone age to determine whether there is any corresponding increase in linear growth. Subsequent evaluation is limited to those with precocious puberty and is aimed at determining the cause and at directing treatment.

The **medical history** should determine when the physical change(s) was first noticed, in the siblings and parents as well as in the patient, seek evidence of growth acceleration, exclude previous history of neurologic disease or trauma or exposure to sex steroids, and identify any associated symptoms of headache, seizures, or abdominal pain.

The **physical examination** should include height, weight, and calculation of growth velocity (cm/year), which often is an early indication of evolving precocious puberty.<sup>251</sup> A fundoscopic examination should be performed to detect papilledema, a sign of increased intracranial pressure. Evaluation of visual fields may reveal evidence to suggest a sellar mass lesion. A careful examination of the skin should be performed to identify any café au lait spots, which suggest the diagnosis of McCune-Albright syndrome.

**Tanner staging** of pubic hair and/or breast development should be performed. The diameter of the glandular breast tissue should be measured, taking care to distinguish it from adipose. Accurate assessments are important for determining whether additional evaluation is warranted.

A measurement of **bone age** is indicated when examination demonstrates signs of early sexual development (Table 9.4).

## TABLE 9.4 Tanner Staging

	Breast	Pubic Hair
Stage 1 (prepubertal)	Elevation of papilla only	No pubic hair
Stage 2	Elevation of the breast and papilla as small mound, increased areola diameter	Sparse, long, pigmented hair, primarily on the labia majora
Stage 3	Further enlargement without separation of the breast and areola	Dark, coarse, curled hair sparsely distributed over the mons
Stage 4	Secondary mound of the areola and papilla above the breast	Adult-type hair, abundant but limited to the mons
Stage 5	Recession of the areola to contour of the breast	Adult-type hair, extending onto the medial thigh

## Endocrine Evaluation and Imaging

**Children with advanced bone age and those having normal bone age accompanied by both breast and pubic hair development, or normal bone age with evidence of accelerated growth and breast or pubic hair development, warrant further endocrine evaluation and imaging.**

Basal and GnRH-stimulated serum gonadotropin levels differentiate gonadotropin-dependent from gonadotropin-independent precocious puberty, which then guides further evaluation. Serum gonadotropin concentrations should be measured using ultrasensitive assays having low detection limits for pediatric patients (approximately 0.1 IU/L).<sup>252,253,254</sup>

The **GnRH stimulation test** is performed by obtaining blood samples before and 30–40 minutes after a single dose of GnRH (100 µg), administered intravenously. Because synthetic GnRH currently is not available in the United States, a GnRH agonist can be used instead,<sup>255,256,257</sup> obtaining blood samples before and 60 minutes after a single dose of leuprolide acetate (20 µg/kg), administered subcutaneously.<sup>257</sup> **The stimulated serum LH concentration is the most useful diagnostic parameter; although a normal threshold value has not been firmly established, due to differences in assay methods and the limited amount of normative data, a stimulated LH value of 3.3–5.0 IU/L defines the upper limit of normal for prepubertal children (Tanner stage 1, T1) with most assays.**<sup>257</sup> Both basal and stimulated serum LH concentrations have high specificity and positive predictive value for diagnosis of gonadotropin-dependent precocious puberty. In a study comparing the results of GnRH stimulation tests performed in normal children (T1) with those obtained in children with gonadotropin-dependent and gonadotropin-independent precocious puberty, the mean basal serum LH concentration was 1.6 IU/L in the group with gonadotropin-dependent precocious puberty and less than 0.6 IU/L in the other two groups. The mean stimulated LH value in the group of children with gonadotropin-dependent precocious puberty was 21.6 IU/L, compared to 3.2 IU/L in normal children (T1) and 1.4 IU/L in the group with gonadotropin-independent precocious puberty.<sup>258</sup>

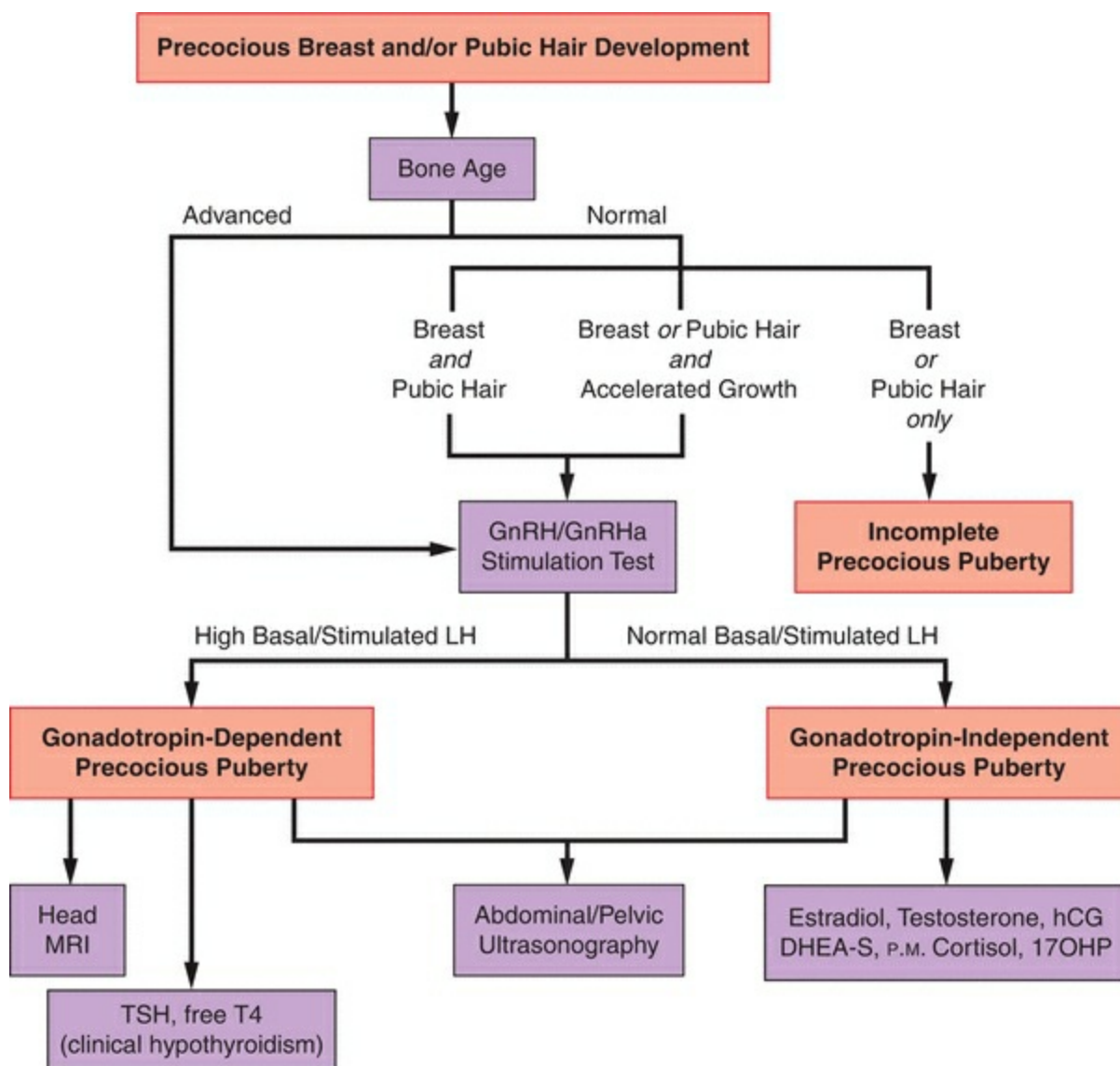
**In children with gonadotropin-dependent precocious puberty (as identified by elevated basal or stimulated serum LH levels), a head MRI is indicated to exclude an intracranial mass lesion.**<sup>257,259</sup> Thyroid function tests (TSH and free T4) should be obtained if there is any clinical evidence of hypothyroidism.

**In children with gonadotropin-independent precocious puberty (as identified by normal basal and stimulated serum LH levels), serum concentrations of estradiol, testosterone and hCG (functional ovarian cysts and tumors, functional adrenal**



tumors), late afternoon cortisol (Cushing syndrome), DHEA-S (premature adrenarche), and 17-OHP (CAH) should be obtained to determine the peripheral source of sex steroid production and the cause of early sexual development.

Abdominal and pelvic ultrasonography is indicated in all girls with precocious puberty to identify functional ovarian cysts or tumors. Ultrasonography is indicated even for those with gonadotropin-dependent precocious puberty because early and repeated or sustained exposure to sex steroids from autonomous peripheral sources can induce a secondary premature maturation of the hypothalamic-pituitary-gonadal axis (Figure 9.7).



**FIGURE 9.7**

# Treatment of Precocious Puberty

The treatment of precocious puberty differs according to whether it is gonadotropin-dependent or gonadotropin-independent and on the underlying cause, when that can be determined. **The principal goals of treatment are to stop or slow development until normal pubertal age, to maximize adult height, and to reduce the risk of psychosocial problems associated with early sexual maturation.**

## Treatment of Gonadotropin-Dependent Precocious Puberty

The decision to treat gonadotropin-dependent precocious puberty depends on the underlying pathology and on the speed of sexual development. In those having an identified intracranial lesion, treatment should be directed to the lesion, if that is possible. In those having no intracranial lesion, the decision to treat should be based primarily on the pace of progression and on the estimated adult height.

**Treatment for gonadotropin-dependent precocious puberty generally is indicated when sexual maturation progresses to the next stage within 3–6 months, when growth velocity is accelerated to greater than 6 cm/year (unless peak height velocity has already passed), when bone age is advanced by 1 year or more, or when predicted adult height is below the target range or is decreasing on serial determinations.**<sup>259</sup> Conversely, those with stable or regressing pubertal signs, normal growth velocity (for age), bone age within 1 year of chronologic age, and a predicted adult height within the target range may not require treatment. In most cases, growth velocity should be monitored for 3–6 months before making the decision to treat.<sup>259</sup> Treatment aimed only at avoiding the potential psychosocial consequences of precocious puberty should be carefully considered because there are few data regarding outcomes and effectiveness.

## GnRH Agonist Treatment

**Long-acting GnRH agonists have proven both safe and effective for the treatment of idiopathic gonadotropin-dependent precocious puberty.**<sup>260,261,262,263,264,265,266,267</sup>

GnRH agonist treatment causes a brief initial “flare” of gonadotropin release, followed by pituitary desensitization (exhaustion of available stores of releasable gonadotropins) and down-regulation (decrease in GnRH receptors). By suppressing the pituitary-gonadal axis, GnRH agonist therapy can prevent progressive pubertal development, and increase final adult height, compared to pretreatment predictions. **Young children and those who exhibit rapidly progressive development can be expected to have early**

**epiphyseal fusion, are at greatest risk for compromised adult height, and can benefit most from treatment.**<sup>257</sup>

In girls under 6 years of age with idiopathic gonadotropin-dependent precocious puberty, treatment with a GnRH agonist can be expected to add 9–10 cm to adult height. In older children already past their peak with slowing growth velocity, treatment can be expected to slow it further, to delay epiphyseal fusion, and to yield slow but steady increases in predicted adult height. In girls between 6 and 8 years of age, GnRH agonist treatment typically results in a gain of 4–7 cm in height, less if bone age is significantly advanced.<sup>257</sup> Girls already close to the age of normal puberty, those with slowly progressive maturation, and girls with a predicted height above 150 cm have less to gain and may not benefit significantly from treatment.<sup>268,269,270</sup>

The choice among the available GnRH agonist formulations depends mostly on physician preference and availability. Depot preparations generally are preferred because of improved compliance. Direct comparisons in randomized trials have not been made, but any of the following treatment regimens generally can be expected to suppress the pituitary-gonadal axis<sup>271,272,273</sup>

- Buserelin 6.3 mg every 2 months
- Goserelin 3.6 mg every month or 9.8 mg every 3 months
- Histrelin 50-mg implant every year
- Leuprolide 3.75–7.5 mg monthly or 11.25 mg every 3 months
- Triptorelin 3.0–3.75 mg monthly or 11.25 mg every 3 months

Nonetheless, the dose of GnRH agonist treatment required can vary significantly.<sup>274</sup> Inadequate treatment can permit progressive sexual development and bone maturation. Conversely, overtreatment can suppress endogenous GH and decrease growth velocity and bone mineral accumulation to levels below those normally expected during the prepubertal years.<sup>275</sup> The adequacy of GnRH agonist treatment can be monitored simply by measuring the serum LH concentration 30–60 minutes after each repeated injection of the agonist; the LH level should be less than 3.0 IU/L, consistent with prepubertal norms after acute GnRH agonist stimulation.<sup>276</sup>

**GnRH agonist treatment should be monitored at 3–6 month intervals with serial physical examinations to detect any progressive pubertal development; bone age also should be evaluated periodically.**<sup>257</sup> Breast development should cease and growth velocity and the pace of advancing bone age should decrease. Pubic hair development may continue due to normal adrenarche.<sup>277</sup> Although bone density may decline during longer durations of treatment, bone mass is regained after treatment ends and peak bone mass is normal; consequently, there is no reason or need to monitor bone

density.<sup>257</sup>

**Treatment with GnRH agonists does not appear to have any significant long-term adverse effects on function of the hypothalamic-pituitary-gonadal axis.<sup>278</sup> It can be continued until the epiphyses are fused or until the pubertal and chronologic ages are appropriately matched. Prompt reactivation of the pituitary-gonadal axis and pubertal development, in a pattern similar to that in normal adolescents, generally follows the discontinuation of treatment.<sup>279</sup> In one Japanese study of 63 girls and 11 boys who were treated with leuporelin for an average of 3.8 years, 96.8% of girls achieved menarche or remenarche within an average of 17.5 ( $\pm 11.2$ ) months after cessation of treatment.<sup>267</sup>**

GnRH agonist therapy also is recommended for treatment of GnRH-secreting hypothalamic hamartomas<sup>193,280</sup>; the tumor can be monitored by serial imaging and risky surgery can be avoided. Treatment for other hypothalamic, pituitary, cerebral, or pineal tumors must be individualized. Many that are small and do not extend around or into vital structures can be excised successfully.

## **Treatment of Gonadotropin-Independent Precocious Puberty**

The treatment of gonadotropin-independent precocious puberty is aimed at the underlying pathology. Girls with functional tumors involving the ovaries or adrenals are treated surgically; hCG-secreting tumors also may require adjunctive radiation or chemotherapy, depending on the type and location of the tumor. Solitary unilateral functional ovarian cysts also can be excised surgically. Children with CAH should receive treatment with glucocorticoids, and those with McCune-Albright syndrome generally are best treated with drugs that inhibit steroidogenesis or hormone action rather than surgery, to preserve fertility.

### **McCune-Albright Syndrome in Girls**

In girls with McCune-Albright syndrome, treatment can be aimed at blocking aromatization and estrogen production, but available evidence indicates that aromatase inhibitors, such as fadrozole, letrozole, and anastrozole, tend to lose their effectiveness over time.<sup>281,282,283,284</sup> The alternative is to block the effects of estrogens by treatment with an antiestrogen such as tamoxifen, which has been used successfully for treatment of associated vaginal bleeding.<sup>285</sup> Bisphosphonate treatment can be useful in the treatment of the fibrous dysplasia of the bone that causes pain and fractures.<sup>286</sup> Those who develop a gonadotropin-dependent component to their precocious development, due to chronic premature exposure to sex steroids, may benefit from adjunctive

treatment with a GnRH agonist, as in children with idiopathic gonadotropin-dependent precocious puberty.<sup>214</sup>

## **Management of Incomplete Precocious Puberty**

Although girls with isolated premature thelarche or premature adrenarche do not require treatment, they do merit regular examinations to detect other emerging evidence of precocious sexual development that may signal the need for further evaluation and possible treatment.

# DELAYED PUBERTY

---

Delayed puberty is defined by absent or incomplete sexual maturation by the age at which 95% of children of the same sex has started pubertal development. **In the United States, breast development, the usual first sign, begins by the age of 12 years in more than 95% of girls.**<sup>140</sup> Delayed puberty results from hypogonadism, which, in turn, can result from an inactive hypothalamic-pituitary axis (hypogonadotropic hypogonadism) or from primary gonadal failure (hypergonadotropic hypogonadism).

**The most common cause of hypogonadotropic hypogonadism is a functional GnRH deficiency, reflecting a constitutional delay in the reactivation of the hypothalamic-pituitary-gonadal axis or the suppressive effects of chronic stress due to illness, malnutrition, or excessive exercise.** GnRH deficiency also can result from genetic defects (e.g., Kallmann syndrome) or anatomical abnormalities (e.g., hypothalamic and pituitary tumors). Other causes of hypogonadotropic hypogonadism include pituitary failure, hypothyroidism, and hyperprolactinemia. Hypergonadotropic hypogonadism can result from idiopathic primary gonadal failure, from previous treatment of malignancy (gonadectomy, chemotherapy, gonadal radiation), or from a variety of congenital and genetic abnormalities or syndromes.

The distribution of diagnostic frequencies among girls with delayed puberty is shown in the table below, representing the findings in a series of 326 patients.<sup>287</sup> The series included all girls who were referred for evaluation of delayed pubertal milestones, including some with only primary amenorrhea relating to müllerian or other developmental anomalies or androgen insensitivity syndrome, who did not have true delayed puberty. In a subsequent study involving 74 females aged 18 years old and younger (mean age  $14 \pm 1.4$  year) referred to a tertiary center solely for the evaluation of delayed puberty, the final diagnosis was constitutional delay in 22 (30%), functional hypogonadotropic hypogonadism (chronic illness, eating disorders, excessive exercise) in 14 (19%), irreversible hypogonadotropic hypogonadism (genetic causes, CNS tumors) in 15 (20%), hypergonadotropic hypogonadism (previous chemotherapy, gonadal radiation, and congenital and genetic abnormalities) in 19 (26%), with 4 patients (5%) left unclassified<sup>288</sup> (Table 9.5).

## **TABLE 9.5 Relative Frequency of Delayed Pubertal Abnormalities**<sup>287</sup>

<b>Hypergonadotropic Hypogonadism</b>		<b>43.0%</b>
Ovarian failure, abnormal karyotype		26.0%
Ovarian failure, normal karyotype		17.0%
46,XX	15.0%	
46,XY	2.0%	
<b>Hypogonadotropic Hypogonadism</b>		<b>31.0%</b>
Reversible		18.0%
Physiologic delay	9.0%	
Weight loss/anorexia	3.0%	
Primary hypothyroidism	1.0%	
Congenital adrenal hyperplasia	1.0%	
Cushing syndrome	0.5%	
Prolactinoma	1.5%	
Irreversible		13.0%
GnRH deficiency	7.0%	
Hypopituitarism	2.0%	
Congenital CNS defects	0.5%	
Other pituitary adenomas	0.5%	
Craniopharyngioma	1.0%	
Malignant pituitary tumor	0.5%	
<b>Eugonadism</b>		<b>26.0%</b>
Müllerian agenesis		14.0%
Vaginal septum		3.0%
Imperforate hymen		0.5%
Androgen insensitivity syndrome		1.0%
Inappropriate positive feedback		7.0%

# Evaluation of Delayed Pubertal Development

The initial evaluation of delayed puberty begins in the same way as that for precocious puberty, with a careful history, physical examination, and a measurement of bone age.

The **medical history** should determine whether pubertal development has not yet started or began and then stopped. A careful evaluation of the previous growth pattern can provide important clues.<sup>289</sup> **Those with constitutional delay typically exhibit delayed growth, adrenarche, and sexual development, associated with declining growth velocity and delayed skeletal maturation.** Other important historical factors include dietary and exercise habits, previous serious illnesses, and medications that might delay the onset or slow the pace of pubertal progression.<sup>290</sup>

**Delayed puberty can be among the first clinical indications of an underlying metabolic disorder, such as inflammatory bowel disease or hypothyroidism.** Neurologic symptoms, including headache, visual disturbances, anosmia, dyskinesia, seizures, and mental retardation, suggest a CNS disease or disorder. Anosmia suggests strongly a genetic cause, such as a KAL1, FGF8, FGFR1, PROK2, or PROKR2 gene mutation (all associated with different forms of Kallmann syndrome). **A complete family history, with emphasis on the age at pubertal milestones in older siblings and parents, also provides useful information; in most patients with constitutional delay, other family members have a similar history.**<sup>288</sup>

The **physical examination** should include height, weight, arm span, and Tanner staging of breast and pubic hair development. Height should be compared to norms for age and for bone age and then carefully monitored for at least 6 months. A eunuchoid body habitus (arm span exceeds height by  $\geq 5$  cm) suggests delayed epiphyseal closure due to hypogonadism. In the presence of breast budding (Tanner stage 2), a normal spontaneous puberty generally can be expected and both the patient and family can be reassured. Congenital malformations such as midline defects and skeletal abnormalities (cleft lip/palate, scoliosis) suggest congenital GnRH deficiency resulting from genetic mutations involving elements of the fibroblast growth factor signaling pathway. As in patients with precocious puberty, a fundoscopic examination should be performed to detect papilledema and visual fields should be evaluated.

A measurement of **bone age** should be obtained for comparison with chronologic age and for assessment of the potential for future growth. **Patients with constitutional delay of puberty typically exhibit a bone age between 12 and 13.5 years, which generally does not progress further without the exposure to gonadal steroids that is required for epiphyseal closure.**



## Laboratory Evaluation and Imaging

The laboratory evaluation of girls with delayed puberty is aimed first at differentiating primary (hypergonadotropic) from secondary (hypogonadotropic) hypogonadism, which typically can be accomplished by measuring the serum FSH, LH, and estradiol concentrations.

By midadolescence, gonadotropin levels, particularly FSH, are grossly elevated in girls with primary gonadal failure.<sup>27</sup> In patients with hypogonadism, low basal gonadotropin levels are consistent with the diagnosis of constitutional delay of puberty, but also with congenital GnRH deficiency or pituitary gonadotropin deficiency. Ultrasensitive immunofluorometric assays for FSH and LH may help to distinguish the low but detectable concentrations typically observed in those with constitutional delay from the undetectable levels in patients with congenital GnRH deficiency, but these assays have not yet been widely validated for use in patients who are truly GnRH deficient.<sup>23</sup> **GnRH agonist stimulation testing generally is not helpful or necessary.** Whereas some have found that stimulation with a GnRH agonist (buserelin, nafarelin, triptorelin) can successfully discriminate constitutional delay of puberty from congenital GnRH deficiency in boys,<sup>291,292,293</sup> similar studies have not been conducted in girls with delayed puberty. Consequently, after excluding other causes, time and serial observations may be required to establish the correct diagnosis.

**When the estradiol level is clearly low, a serum FSH level in the low normal range has the same interpretation and clinical implication as a frankly low FSH concentration.** If the hypothalamic-pituitary-ovarian axis was intact and functioning normally, the FSH level should be high when estrogen levels are grossly low; therefore, a “normal” value is abnormally low in that clinical context and indicates hypothalamic-pituitary suppression or dysfunction. Moreover, although the level of immunoreactive FSH may be normal, the level of biologically active FSH may not be, because patients with hypogonadotropic hypogonadism may secrete gonadotropins having altered patterns of glycosylation and reduced biologic activity.<sup>294</sup>

Further laboratory evaluation is directed toward determining the cause of hypogonadotropic or hypergonadotropic hypogonadism, once that is established.

### Hypogonadotropic Hypogonadism

In girls with hypogonadotropic hypogonadism, measurement of the serum **prolactin** concentration is indicated to identify those with hyperprolactinemia, which can cause either delayed or arrested pubertal development, depending on when it arises. Hyperprolactinemia can result from excessive secretion by a pituitary lactotrope adenoma, from any other hypothalamic or pituitary tumor or disorder that interrupts the

normal delivery of hypothalamic dopamine via the tuberoinfundibular tract, or from medications that interfere with the actions of dopamine. **Therefore, hyperprolactinemia is an indication for imaging by MRI, except when it can be attributed confidently to medications.**

Measurement of the serum **TSH and free thyroxine (T4)** concentrations also is indicated to identify those who may have primary or secondary hypothyroidism, particularly if growth velocity has slowed and the bone age is grossly delayed.

The serum **DHEA-S** concentration may be helpful for distinguishing constitutional delay of puberty from congenital GnRH deficiency. Patients with congenital GnRH deficiency are more likely to have a normal adrenarche than those with constitutional delay, although values in the two groups frequently overlap.<sup>295</sup>

Other laboratory tests are aimed at identifying those who may have an occult chronic illness, such as chronic inflammatory bowel disease, liver disease, or anorexia nervosa, and should include a **complete blood count, erythrocyte sedimentation rate, and liver function tests.**

Although **pelvic ultrasonography** can be used to determine the presence or absence of a uterus in virginal girls, it must be interpreted cautiously because results can be misleading when the reproductive organs are immature and very small and generally are unnecessary. Whereas müllerian anomalies are a common cause of primary amenorrhea, they are not associated specifically with delayed puberty.

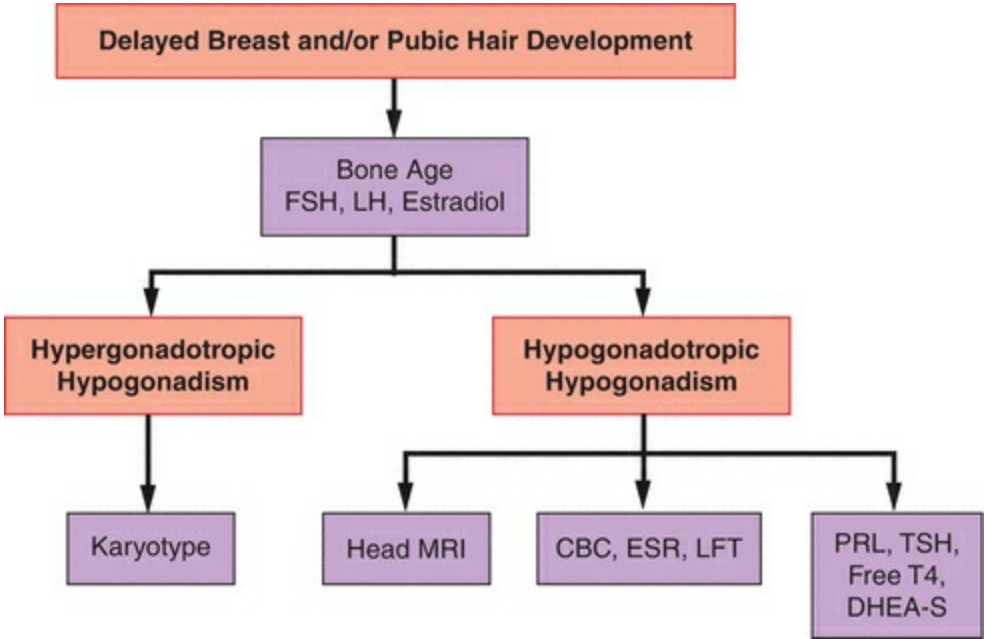
**A head MRI should be obtained in patients with hypogonadotropic hypogonadism and those with neurologic signs or symptoms.** In addition to detecting mass lesions, imaging can reveal the presence or absence of the olfactory bulbs and tracts (absent in Kallmann syndromes).

## **Hypergonadotropic Hypogonadism**

**A karyotype should be obtained in all girls with hypergonadotropic hypogonadism to detect chromosomal abnormalities, except when a history of previous chemotherapy or gonadal radiation provides an obvious explanation.** The most common disorder of this type is gonadal dysgenesis, with Turner syndrome (45,X) being the prototype. In addition to other structural X chromosome abnormalities (e.g., deletions, rings, and isochromosomes), karyotype will identify those harboring a Y chromosome (e.g., 46,XY, Swyer syndrome), in whom gonadectomy will be indicated due to the significant risk for malignant transformation in occult testicular elements (20–30%).

In patients with hypergonadotropic hypogonadism and a normal (46,XX) karyotype, the diagnostic possibilities include 17-hydroxylase deficiency, a rare steroidogenic

enzyme defect associated with sexual infantilism and hypertension, and other uncommon causes of primary ovarian failure, all of which are discussed in [Chapter 10](#) ([Figure 9.8](#)).



**FIGURE 9.8**

# Treatment of Delayed Puberty

The first priority in the treatment of delayed puberty is to correct the specific cause, when that is possible, such as thyroid hormone therapy for hypothyroidism, dopamine agonist therapy for hyperprolactinemia, and excision of a craniopharyngioma or other operable central lesion. In those with no such identifiable cause, congenital GnRH deficiency must be distinguished from constitutional delay of puberty, but in most, a final diagnosis can be established only after serial observations; however, treatment options are the same in either case.

Patients with congenital GnRH deficiency or constitutional delay of puberty can be managed expectantly, providing reassurance and psychological support, or with hormone therapy, which may be appropriate for those with severe pubertal delay or serious psychosocial concerns that cannot be resolved with reassurance and education. **In general, sex hormone therapy should be limited to girls over 12 years of age having few or no signs of sexual maturation causing significant distress or anxiety.**

**The goals of short-term hormone therapy are to foster age-appropriate secondary sexual development and to induce a growth spurt and a normal adolescent increase in bone density without causing premature epiphyseal closure, which requires that bone age be monitored at 6-monthly intervals during treatment.** In those who prove ultimately to have an isolated GnRH deficiency, the longer-term goals are to maintain sex hormone levels in the normal physiologic range and to induce ovulation with exogenous gonadotropin therapy when fertility becomes a priority. Oral or transdermal estrogen therapy can be used, beginning at doses well below those used for adults (e.g., 0.25–0.5 mg oral micronized estradiol or its equivalent), increasing gradually at intervals of 3–6 months according to response (Tanner stage, bone age), with the goal of completing sexual maturation over a period of 2–3 years. **A progestin should not be added to the treatment regimen until there is substantial breast development and full contour breast growth has plateaued, because premature progestin treatment can adversely affect breast growth or contours.** In general, progestin therapy can safely begin once menses have begun or after 12–24 months of estrogen treatment. Once breast development has been accomplished and menses are established, hormone therapy can be discontinued for 1–3 months, at intervals, to observe whether spontaneous menses will begin, as can be expected in girls with constitutional delay of puberty. Persistent hypogonadism beyond 18 years of age clearly suggests congenital GnRH deficiency.

In general, GH therapy is best limited to those with documented GH deficiency. Serum GH and IGF-I levels typically are low in patients with constitutional delay of puberty but increase after treatment with estrogen and usually are normal in those with

congenital GnRH deficiency.

# GROWTH PROBLEMS IN NORMAL ADOLESCENTS

---

Perhaps, the worst thing about an adolescent growth problem is that it makes the individual feel “different.” It is probably true that, more than anyone else, the adolescent does not like to be different. Therefore, concerns over unusually short or tall stature deserve attention and should not be dismissed.

Growth in height is a continuous but not a linear process. There are three distinct phases of growth. The first is the infantile phase, which is characterized by rapid growth amounting to a total of 30–35 cm during the first 2 years of life. The next phase is the childhood phase, during which growth proceeds at a relatively constant pace of 5–7 cm/year, often slowing in late childhood. The last is the pubertal phase, which is characterized by a growth spurt at a rate of 8–14 cm/year, reflecting the effects of increasing levels of both GH and sex steroid hormones.<sup>296,297</sup>

The contribution of heredity to final adult height is difficult to predict accurately, but a child’s height potential can be estimated by calculating the **midparental height**; for girls, midparental height is calculated as follows:

$$\frac{(\text{father's height} - 13 \text{ cm}) + (\text{mother's height})}{2}$$

**Target height** represents a range of heights encompassing the 3rd to 97th percentiles for expected adult height, equating with the midparental height  $\pm 8.5$  cm.<sup>298</sup> For children with delayed or accelerated growth, height should be adjusted to the appropriate percentile based on bone age, rather than chronologic age, to permit a more accurate judgment regarding whether growth is consistent with genetic potential.

**The basic and essential laboratory test in the evaluation of perceived abnormal growth is a left hand/wrist x-ray for bone age.** The Bayley-Pinneau tables (found at the end of this chapter) can be used to determine a **predicted adult height**, based on current height and bone age, in reference to the Greulich-Pyle Atlas.<sup>299</sup> The predicted adult height is the number found where the column corresponding to the patient’s current height intersects the row corresponding to her bone age. If bone age is within 1 year of chronologic age, the table for average girls should be used. If bone age is accelerated or delayed by 1 year or more, the tables for children with accelerated or delayed growth should be used, with one exception. Height predictions for girls with idiopathic GnRH-dependent precocious puberty are more accurate when using the table for average girls.<sup>300</sup>

# Short Stature

Short stature is defined as height 2 or more standard deviations below the mean height for children of the same sex and chronologic age, as determined by plotting height on an appropriate growth chart. **Accurate serial measurements of height and growth velocity are perhaps the most useful tool in the evaluation of children with growth failure.**<sup>301</sup> **The pattern of growth is more important than any single point measurement.** Slowing growth that increasingly deviates from a previously defined pattern (percentile) is the key finding. **Children should grow at a rate of at least 5 cm/year from age 4 year to the onset of puberty.**

The most common causes of short stature are familial (genetic) and constitutional delay of growth; both are characterized by a normal growth velocity. If growth velocity is abnormally low (less than fifth percentile for age), a thorough evaluation for the many potential causes is warranted, as described below.

Short stature is a feature of a variety of chromosomal (Down syndrome, Turner syndrome) and other genetic disorders (Noonan syndrome, Russell-Silver syndrome) and commonly is associated with intrauterine growth restriction or infections and maternal exposures during pregnancy such as smoking and alcohol. Children with short stature relating to endocrine disorders such as Cushing syndrome, GH deficiency, and hypothyroidism usually are overweight for height. In contrast, those with malnutrition due to an eating disorder, excessive exercise, malabsorption, or other systemic illness typically are underweight for height and merit evaluation for gastrointestinal,<sup>302,303</sup> heart, pulmonary,<sup>304</sup> and renal disease.<sup>305</sup>

**Idiopathic short stature** describes children whose height is more than 2 standard deviations below the mean for age with no identifiable endocrine, metabolic, or other cause. Such children generally exhibit low normal growth velocity and have normal serum IGF-I levels. Those with genetic or familial short stature typically have normal bone age and a predicted adult height within the target range, whereas those with constitutional delay of growth have delayed bone age. Recent evidence has suggested that 2–15% of children with idiopathic short stature may have mutations in the SHOX (Short Stature Homeobox) gene, located at the distal tip of the short arm of the X chromosome (Xp22.33).<sup>306,307,308</sup> Affected children tend to have short forearms and lower legs, Madelung deformity of the forearm (a congenital subluxation or dislocation of the distal ulna), cubitus valgus (wide carrying angle of the arm), a high-arched palate, and muscle hypertrophy, compared to those without such mutations.<sup>309</sup> Additional mutations with similar phenotype have been found on various autosomal chromosomes like FGFR3 (4p16.3), ACAN (15q26.1), NPPC (2q37), and NPR2 (9p13).<sup>310</sup>

## Evaluation

Although it is unlikely that a patient with congenital hypothyroidism will present undiagnosed and untreated as an adolescent, thyroid function always should be evaluated. Because both primary and secondary hypothyroidism can cause growth failure, both the serum TSH and free T4 concentrations should be measured. Cushing syndrome (hypercortisolism) is rare in children, except when it results from excess glucocorticoid treatment. Children with congenital GH deficiency generally are not difficult to recognize, usually presenting as young children with severe growth failure, delayed bone age, and very low serum concentrations of IGF-I and its major binding protein, IGFBP-3. Provocative tests of GH secretion are required to establish the diagnosis.

The evaluation of children with short stature should include the following:

- Bone age
- A complete blood count and erythrocyte sedimentation rate
- Electrolytes, creatinine, bicarbonate, calcium, phosphate, alkaline phosphatase, and albumin
- TSH, free T4, IGF-I (and IGFBP-3 in children under 3 years of age)
- Antiendomysial antibodies (a serologic screen for celiac disease)
- Karyotype (to exclude Turner syndrome or other X chromosome abnormalities)

A head MRI is not required to establish the diagnosis of idiopathic short stature, but should be considered in children with known GH deficiency and those with signs or symptoms of hypothalamic-pituitary dysfunction.

## Treatment

GH therapy for idiopathic short stature was approved by the U.S. Food and Drug Administration in 2003 and is considered indicated for girls whose height is more than 2.25 standard deviations below the mean for age whose epiphyses are not closed and whose predicted adult height is less than 59 inches. **However, GH treatment of children with idiopathic short stature is controversial, because the response to therapy is unpredictable and typically quite modest<sup>311,312,313,314</sup> and because evidence that short stature has significant psychosocial consequences is lacking.<sup>315,316,317</sup>**

Most children with idiopathic short stature, particularly those with constitutional delay of growth, exhibit catch-up growth during puberty without treatment.<sup>311,318</sup> Moreover, the average increase in height is only approximately 4–6 cm after more than



5 years of treatment.<sup>313</sup> The optimal age for starting treatment is between age 5 years and early puberty.<sup>319</sup>

GH treatment has relatively few potential adverse effects.<sup>311,313,320</sup> Although high-dose treatment has been reported to advance the onset of puberty and epiphyseal closure,<sup>321</sup> lower doses do not.<sup>322</sup> Current evidence suggests that the impact of treatment correlates with serum IGF-I levels and that treatment can be optimized when the dose of GH is adjusted to maintain a normal IGF-I concentration.<sup>319</sup> **However, GH therapy generally should be limited to children whose short stature is a significant disability and whose self-image and socialization are judged likely to improve significantly with an increase in height.**<sup>323,324</sup> The associated costs and potential benefits must be weighed carefully because the costs of GH therapy are extremely high. In the United States, the cost has been estimated to exceed \$50,000 per inch gained in adult height!<sup>325</sup>

An alternative approach to treatment involves the use of a long-acting GnRH agonist to delay pubertal development and epiphyseal fusion. However, the modest impact of such treatment (ranging up to only 4 cm in increased height) comes at the cost of a substantial decrease in bone mineral density accretion.<sup>326</sup> Although treatment with an aromatase inhibitor might also seem logical, such therapy actually slows growth in girls via profound inhibition of estrogen production.

# Tall Stature

Tall stature is defined as height 2 or more standard deviations above the mean height for children of the same sex and chronologic age. Although tall stature is nearly as common as short stature, it is perceived as more socially acceptable and less commonly perceived as a problem. Most children with tall stature, like those with short stature, represent the extremes of a normal distribution of heights and only a few have a specific growth abnormality.<sup>327</sup>

Abnormally rapid growth during childhood and adolescence can result from precocious pubertal development, GH excess,<sup>328</sup> hyperthyroidism,<sup>329</sup> sex hormone deficiency or insensitivity,<sup>330,331</sup> or rare autosomal recessive disorders such as familial glucocorticoid deficiency<sup>332</sup> or resistance<sup>333</sup> and congenital total lipodystrophy.<sup>334</sup> Patients with Marfan syndrome,<sup>335</sup> homocystinuria,<sup>336</sup> and neurofibromatosis type I also can be unusually tall.<sup>337</sup>

The diagnosis of familial or constitutional tall stature generally is established by family history and the absence of dysmorphic features, distinguishing it from disorders of excessive growth. **In most tall but otherwise normal children, a careful family history, physical examination, and bone age generally are all that is required to establish the diagnosis and to provide reassurance.** Serial measurements of growth at 6–12-month intervals can help to confirm that growth is in the high normal range but not excessive. The Bayley-Pinneau tables (found at the end of this chapter) can be used to predict adult height in tall girls and become more accurate after the age of 12 years; in younger children, they may tend to overestimate adult height.<sup>338</sup>

## Treatment

As in otherwise normal short children and adolescents, the treatment of tall children and adolescents is controversial, generally discouraged, and should be limited to those whose tall stature is the cause of significant psychosocial problems.<sup>339,340,341</sup>

Sex steroids have been used to treat tall girls and boys for decades, the goal being to promote early epiphyseal fusion.<sup>342,343</sup> **The earlier treatment is started, the greater the likelihood that adult height will be diminished.** The stage of secondary sexual development is relevant because the adolescent growth spurt precedes menarche, and treatment must begin before menarche to be optimally effective.<sup>327</sup> Although that implies that treatment could begin as early as age 8 or 9 years, the usual age to begin treatment is between 10 and 12 years. However, treatment that begins after menarche can still achieve up to an inch of growth reduction.<sup>344,345</sup> A typical starting dose is 15–30 µg of ethinyl estradiol, which can be administered in a low-dose oral contraceptive

pill. Treatment should continue until the epiphyses are closed, as can be determined by serial measurements of bone age at 6–12-month intervals during treatment.<sup>346</sup> The mean adjusted reduction in height ranges up to 6 cm, but averages a more modest 1–2.5 cm,<sup>338</sup> and treatment is not without potential complications and future consequences. Common side effects include nausea, water retention and weight gain, and menorrhagia. Whereas an early study found no adverse effects of treatment on future fertility,<sup>347</sup> a more recent study involving 1,243 adult women with hereditary tall stature observed that the risk for future infertility was significantly increased and that cycle fecundability was decreased by approximately 40% in those treated with estrogen as adolescents, compared to those who received no treatment.<sup>348</sup> This was further confirmed in a subsequent study from the Netherlands involving 125 tall women aged 20–42 years, of whom 52 women had been treated with 100 µg and 43 with 200 µg of ethinyl estradiol in adolescence.<sup>349</sup> In that study, 80% of untreated women achieved pregnancy within 1 year, compared to 69% of women treated with 100 µg and 59% of women treated with 200 µg ethinyl estradiol; there was a significant correlation between the estrogen dose and time to pregnancy. The mechanism responsible for the effect is still unknown, but it might be related to ovarian function and follicular depletion. In a study from the same Dutch group comprising 285 tall women (157 treated and 128 untreated), treated women had significantly higher odds of being diagnosed with imminent ovarian failure (OR 2.83, 95% CI = 1.04–7.68).<sup>350</sup> Serum FSH levels in these women were significantly increased, whereas antral follicle counts and serum antimüllerian hormone levels were decreased<sup>350</sup> (Tables 9.6, 9.7, 9.8).

## **TABLE 9.6 Bayley-Pinneau Table for Average Girls<sup>299</sup>**



12/6	13/0	13/6	14/0	14/6	15/0	15/6	16/0	16/6	17/0	17/6	18/0	
												37
												38
												39
												40
												41
												42
												43
												44
												45
												46
												47
51.0												48
52.1	51.1											49
53.1	52.2	51.3	51.0									50
54.2	53.2	52.4	52.0	51.7	51.5	51.4	51.2	51.2	51.1	51.0	51.0	51
55.3	54.3	53.4	53.1	52.7	52.5	52.4	52.2	52.2	52.1	52.0	52.0	52
56.3	55.3	54.4	54.1	53.8	53.5	53.4	53.2	53.2	53.1	53.0	53.0	53
57.4	56.4	55.4	55.1	54.8	54.5	54.4	54.2	54.2	54.1	54.0	54.0	54
58.4	57.4	56.5	56.1	55.8	55.6	55.4	55.2	55.2	55.1	55.0	55.0	55
59.5	58.5	57.5	57.1	56.8	56.6	56.4	56.2	56.2	56.1	56.0	56.0	56
60.6	59.5	58.5	58.2	57.8	57.6	57.4	57.2	57.2	57.1	57.0	57.0	57
61.6	60.5	59.5	59.2	58.8	58.6	58.4	58.2	58.2	58.1	58.0	58.0	58
62.7	61.6	60.6	60.2	59.8	59.6	59.4	59.2	59.2	59.1	59.0	59.0	59
63.8	62.6	61.6	61.2	60.9	60.6	60.4	60.2	60.2	60.1	60.0	60.0	60
64.8	63.7	62.6	62.2	61.9	61.6	61.4	61.2	61.2	61.1	61.0	61.0	61
65.9	64.7	63.7	63.3	62.9	62.6	62.4	62.2	62.2	62.1	62.0	62.0	62
67.0	65.8	64.7	64.3	63.9	63.6	63.4	63.3	63.2	63.1	63.0	63.0	63
68.0	66.8	65.7	65.3	64.9	64.6	64.4	64.3	64.2	64.1	64.0	64.0	64
69.1	67.8	66.7	66.3	65.9	65.7	65.5	65.3	65.2	65.1	65.0	65.0	65
70.1	68.9	67.8	67.3	66.9	66.7	66.5	66.3	66.2	66.1	66.0	66.0	66
71.2	69.9	68.8	68.4	68.0	67.7	67.5	67.3	67.2	67.1	67.0	67.0	67
72.3	71.0	69.8	69.4	69.0	68.7	68.5	68.3	68.2	68.1	68.0	68.0	68
73.3	72.0	70.8	70.4	70.0	69.7	69.5	69.3	69.2	69.1	69.0	69.0	69
74.4	73.1	71.9	71.4	71.0	70.7	70.5	70.3	70.2	70.1	70.0	70.0	70
	74.1	72.9	72.4	72.0	71.7	71.5	71.3	71.2	71.1	71.0	71.0	71
		73.9	73.5	73.0	72.7	72.5	72.3	72.2	72.1	72.0	72.0	72
		74.9	74.5	74.0	73.7	73.5	73.3	73.2	73.1	73.0	73.0	73
					74.7	74.5	74.3	74.2	74.1	74.0	74.0	74

**TABLE 9.7 Bayley-Pinneau Table for Accelerated  
Girls<sup>299</sup>**



12/6	13/0	13/6	14/0	14/6	15/0	15/6	16/0	16/6	17/0	17/6	
											37
											38
											39
											40
											41
											42
											43
											44
											45
											46
											47
51.9											48
53.0	51.9	50.9									49
54.1	52.9	51.9	51.4	51.0							50
55.2	54.0	53.0	52.5	52.0	51.7	51.5	51.4	51.3	51.1	51.0	51
56.3	55.0	54.0	53.5	53.1	52.7	52.5	52.4	52.3	52.1	52.0	52
57.4	56.1	55.0	54.5	54.1	53.8	53.5	53.4	53.3	53.1	53.0	53
58.4	57.1	56.1	55.6	55.1	54.8	54.5	54.4	54.3	54.1	54.0	54
59.5	58.2	57.1	56.6	56.1	55.8	55.5	55.4	55.3	55.1	55.0	55
60.6	59.3	58.2	57.6	57.1	56.8	56.5	56.4	56.3	56.1	56.0	56
61.7	60.3	59.2	58.6	58.2	57.8	57.6	57.4	57.3	57.1	57.0	57
62.8	61.4	60.2	59.7	59.2	58.8	58.6	58.4	58.3	58.1	58.0	58
63.9	62.4	61.3	60.7	60.2	59.8	59.6	59.4	59.3	59.1	59.0	59
64.9	63.5	62.3	61.7	61.2	60.9	60.6	60.4	60.3	60.1	60.0	60
66.0	64.6	63.3	62.8	62.2	61.9	61.6	61.4	61.3	61.1	61.0	61
67.1	65.6	64.4	63.8	63.3	62.9	62.6	62.4	62.3	62.1	62.0	62
68.2	66.7	65.4	64.8	64.3	63.9	63.6	63.4	63.3	63.1	63.0	63
69.3	67.7	66.5	65.8	65.3	64.9	64.6	64.4	64.3	64.1	64.0	64
70.3	68.8	67.5	66.9	66.3	65.9	65.7	65.5	65.3	65.1	65.0	65
71.4	69.8	68.5	67.9	67.3	66.9	66.7	66.5	66.3	66.1	66.0	66
72.5	70.9	69.6	68.9	68.4	68.0	67.7	67.5	67.3	67.1	67.0	67
73.6	72.0	70.6	70.0	69.4	69.0	68.7	68.5	68.3	68.1	68.0	68
74.7	73.0	71.7	71.0	70.4	70.0	69.7	69.5	69.3	69.1	69.0	69
	74.1	72.7	72.0	71.4	71.0	70.7	70.5	70.3	70.1	70.0	70
		73.7	73.0	72.4	72.0	71.7	71.5	71.4	71.1	71.0	71
		74.8	74.1	73.5	73.0	72.7	72.5	72.4	72.1	72.0	72
				74.5	74.0	73.7	73.5	73.4	73.1	73.0	73
						74.4	74.5	74.4	74.1	74.0	74



**TABLE 9.8 Bayley-Pinneau Table for Delayed Girls<sup>299</sup>**



12/0	12/6	13/0	13/6	14/0	14/6	15/0	15/6	16/0	16/6	17/0	
											38
											39
											40
											41
											42
											43
											44
											45
											46
											47
51.5											48
52.6	51.6										49
53.6	52.7	51.9	51.2								50
54.7	53.7	52.9	52.2	51.9	51.6	51.3	51.2	51.1	51.1	51.0	51
55.8	54.8	53.9	53.2	52.9	52.6	52.3	52.2	52.1	52.1	52.0	52
56.9	55.8	55.0	54.2	53.9	53.6	53.3	53.2	53.1	53.1	53.0	53
57.9	56.9	56.0	55.3	54.9	54.6	54.3	54.2	54.1	54.1	54.0	54
59.0	58.0	57.1	56.3	56.0	55.6	55.3	55.2	55.1	55.1	55.0	55
60.1	59.0	58.1	57.3	57.0	56.6	56.3	56.2	56.1	56.1	56.0	56
61.2	60.1	59.1	58.3	58.0	57.6	57.3	57.2	57.1	57.1	57.0	57
62.2	61.1	60.2	59.4	59.0	58.6	58.3	58.2	58.1	58.1	58.0	58
63.3	62.2	61.2	60.4	60.0	59.7	59.4	59.2	59.1	59.1	59.0	59
64.4	63.2	62.2	61.4	61.0	60.7	60.4	60.2	60.1	60.1	60.0	60
65.5	64.3	63.3	62.4	62.1	61.7	61.4	61.2	61.1	61.1	61.0	61
66.5	65.3	64.3	63.5	63.1	62.7	62.4	62.2	62.1	62.1	62.0	62
67.6	66.4	65.3	64.5	64.1	63.7	63.4	63.3	63.1	63.1	63.0	63
68.7	67.4	66.4	65.5	65.1	64.7	64.4	64.3	64.1	64.1	64.0	64
69.7	68.5	67.4	66.5	66.1	65.7	65.4	65.3	65.1	65.1	65.0	65
70.8	69.5	68.5	67.6	67.1	66.7	66.4	66.3	66.1	66.1	66.0	66
71.9	70.6	69.5	68.6	68.2	67.7	67.4	67.3	67.1	67.1	67.0	67
73.0	71.7	70.5	69.6	69.2	68.8	68.4	68.3	68.1	68.1	68.0	68
74.0	72.7	71.6	70.6	70.2	69.8	69.4	69.3	69.1	69.1	69.0	69
	73.8	72.6	71.6	71.2	70.8	70.4	70.3	70.1	70.1	70.0	70
	74.8	73.6	72.7	72.2	71.8	71.4	71.3	71.1	71.1	71.0	71
		74.7	73.7	73.3	72.8	72.4	72.3	72.1	72.1	72.0	72
			74.7	74.3	73.8	73.4	73.3	73.1	73.1	73.0	73
				74.8	74.4	74.3	74.1	74.1	74.1	74.0	74

# REFERENCES

1. **Dahl RE**, Adolescent brain development: a period of vulnerabilities and opportunities. Keynote address, *Ann N Y Acad Sci* 1021:1, 2004.
2. **Knobil E**, Remembrance: the discovery of the hypothalamic gonadotropin-releasing hormone pulse generator and of its physiological significance, *Endocrinology* 131:1005, 1992.
3. **Vazquez-Martinez R, Shorte SL, Boockfor FR, Frawley LS**, Synchronized exocytotic bursts from gonadotropin-releasing hormone-expressing cells: dual control by intrinsic cellular pulsatility and gap junctional communication, *Endocrinology* 142:2095, 2001.
4. **Herbison AE, Pape JR, Simonian SX, Skynner MJ, Sim JA**, Molecular and cellular properties of GnRH neurons revealed through transgenics in the mouse, *Mol Cell Endocrinol* 185:185, 2001.
5. **Schwanzel-Fukuda M, Crossin KL, Pfaff DW, Bouloux PM, Hardelin JP, Petit C**, Migration of luteinizing hormone-releasing hormone (LHRH) neurons in early human embryos, *J Comp Neurol* 366:547, 1996.
6. **Kaplan SL, Grumbach MM, Aubert ML**, The ontogenesis of pituitary hormones and hypothalamic factors in the human fetus: maturation of central nervous system regulation of anterior pituitary function, *Recent Prog Horm Res* 32:161, 1976.
7. **Park SJ, Goldsmith LT, Weiss G**, Age-related changes in the regulation of luteinizing hormone secretion by estrogen in women, *Exp Biol Med (Maywood)* 227:455, 2002.
8. **Kaplan SL, Grumbach MM**, Pituitary and placental gonadotrophins and sex steroids in the human and sub-human primate fetus, *Clin Endocrinol Metab* 7:487, 1978.
9. **DiVall SA, Radovick S**, Pubertal development and menarche, *Ann N Y Acad Sci* 1135:19, 2008.
10. **Styne DM**, Physiology of puberty, *Horm Res* 41(Suppl 2):3, 1994.
11. **Grumbach MM**, The neuroendocrinology of human puberty revisited, *Horm Res* 57(Suppl 2):2, 2002.
12. **Winter JS, Faiman C, Hobson WC, Prasad AV, Reyes FI**, Pituitary-gonadal relations in infancy. I. Patterns of serum gonadotropin concentrations from birth to four years of age in man and chimpanzee, *J Clin Endocrinol Metab* 40:545, 1975.
13. **Waldhauser F, Weissenbacher G, Frisch H, Pollak A**, Pulsatile secretion of gonadotropins in early infancy, *Eur J Pediatr* 137:71, 1981.
14. **Burger HG, Famada Y, Bangah ML, McCloud PI, Warne GL**, Serum gonadotropin, sex steroid, and immunoreactive inhibin levels in the first two years of life, *J Clin Endocrinol Metab* 72:682, 1991.
15. **Andersson A-M, Toppari J, Haavisto A-M, Petersen JH, Simell T, Simell O, Skakkebaek NE**, Longitudinal reproductive hormone profiles in infants: peak of inhibin B levels in infant boys exceeds levels in adult men, *J Clin Endocrinol Metab* 83:675, 1998.
16. **Winter JS, Hughes IA, Reyes FI, Faiman C**, Pituitary-gonadal relations in infancy: 2. Patterns of serum gonadal steroid concentrations in man from birth to two years of age, *J Clin Endocrinol Metab* 42:679, 1976.
17. **Plant TM**, Hypothalamic control of the pituitary-gonadal axis in higher primates: key advances over the last two decades, *J Neuroendocrinol* 20:719, 2008.
18. **Wildt L, Marshall G, Knobil E**, Experimental induction of puberty in the infantile female rhesus monkey, *Science* 207:1373, 1980.
19. **Jakacki RI, Kelch RP, Sander SE, Lloyd JS, Hopwood NJ, Marshall JC**, Pulsatile secretion of luteinizing hormone in children, *J Clin Endocrinol Metab* 53:453, 1982.
20. **Oerter KE, Urarte MM, Rose SR, Barnes KM, Cutler GB**, Gonadotropin secretory dynamics during puberty in normal girls and boys, *J Clin Endocrinol Metab* 71:1251, 1990.
21. **Dunkel L, Alftan H, Stenman U-H, Selstam G, Rosberg S, Albertsson-Wikland K**, Developmental changes in 24-hour profiles of luteinizing hormone and follicle-stimulating hormone from prepuberty to midstages of puberty in boys, *J Clin Endocrinol Metab* 74:890, 1992.
22. **Apter D, Butzow TL, Laughlin GA, Yen SS**, Gonadotropin-releasing hormone pulse generator activity during pubertal transition in girls: pulsatile and diurnal patterns of circulating gonadotropins, *J Clin Endocrinol Metab*

76:940, 1993.

23. **Wu FC, Butler GE, Kelnar CJ, Huhtaniemi I, Veldhuis JD**, Ontogeny of pulsatile gonadotropin releasing hormone secretion from midchildhood, through puberty, to adulthood in the human male: a study using deconvolution analysis and an ultrasensitive immunofluorometric assay, *J Clin Endocrinol Metab* 81:1798, 1996.
24. **Mitamura R, Yano K, Suzuki N, Ito Y, Makita Y, Okuno A**, Diurnal rhythms of luteinizing hormone, follicle-stimulating hormone, testosterone, and estradiol secretion before the onset of female puberty in short children, *J Clin Endocrinol Metab* 85:1074, 2000.
25. **Kulin HE, Grumbach MM, Kaplan SL**, Changing sensitivity of the pubertal gonadal hypothalamic feedback mechanism in man, *Science* 166:1012, 1969.
26. **Kelch RP, Kaplan SL, Ghumbach MM**, Suppression of urinary and plasma follicle-stimulating hormone by exogenous estrogens in prepubertal and pubertal children, *J Clin Invest* 52:1122, 1973.
27. **Conte FA, Grumbach MM, Kaplan SL**, A diphasic pattern of gonadotropin secretion in patients with the syndrome of gonadal dysgenesis, *J Clin Endocrinol Metab* 40:670, 1975.
28. **Burstein S, Schaff-Blass E, Blass J, Rosenfield RL**, The changing ratio of bioactive to immunoreactive luteinizing hormone (LH) through puberty principally reflects changing LH radioimmunoassay dose-response characteristics, *J Clin Endocrinol Metab* 61:508, 1985.
29. **Sehested A, Juul AA, Andersson AM, Petersen JH, Jensen TK, Muller J, Skakkebaek NE**, Serum inhibin A and inhibin B in healthy prepubertal, pubertal, and adolescent girls and adult women: relation to age, stage of puberty, menstrual cycle, follicle-stimulating hormone, luteinizing hormone, and estradiol levels, *J Clin Endocrinol Metab* 85:1634, 2000.
30. **Legro RS, Lin HM, Demers LM, Lloyd T**, Rapid maturation of the reproductive axis during perimenarche independent of body composition, *J Clin Endocrinol Metab* 85:1021, 2000.
31. **Mitsushima D, Hei DL, Terasawa E**, gamma-Aminobutyric acid is an inhibitory neurotransmitter restricting the release of luteinizing hormone-releasing hormone before the onset of puberty, *Proc Natl Acad Sci U S A* 91:395, 1994.
32. **Mitsushima D, Marzban F, Luchansky LL, Burich AJ, Keen KL, Durning M, Golos TG, Terasawa E**, Role of glutamic acid decarboxylase in the prepubertal inhibition of the luteinizing hormone releasing hormone release in female rhesus monkeys, *J Neurosci* 16:2563, 1996.
33. **Keen KL, Burich AJ, Mitsushima D, Kasuya E, Terasawa E**, Effects of pulsatile infusion of the GABA(A) receptor blocker bicuculline on the onset of puberty in female rhesus monkeys, *Endocrinology* 140:5257, 1999.
34. **Fritschy JM, Paysan J, Enna A, Mohler H**, Switch in the expression of rat GABAA-receptor subtypes during postnatal development: an immunohistochemical study, *J Neurosci* 14:5302, 1994.
35. **Pau KY, Berria M, Hess DL, Spies HG**, Hypothalamic site-dependent effects of neuropeptide Y on gonadotropin-releasing hormone secretion in rhesus macaques, *J Neuroendocrinol* 7:63, 1995.
36. **El Majdoubi M, Sahu A, Ramaswamy S, Plant TM**, Neuropeptide Y: a hypothalamic brake restraining the onset of puberty in primates, *Proc Natl Acad Sci U S A* 97:6179, 2000.
37. **Gore AC, Mitsushima D, Terasawa E**, A possible role of neuropeptide Y in the control of the onset of puberty in female rhesus monkeys, *Neuroendocrinology* 58:23, 1993.
38. **Woller MJ, Terasawa E**, Infusion of neuropeptide Y into the stalk-median eminence stimulates in vivo release of luteinizing hormone-release hormone in gonadectomized rhesus monkeys, *Endocrinology* 128:1144, 1991.
39. **Brann DW, Mahesh VB**, Excitatory amino acids: evidence for a role in the control of reproduction and anterior pituitary hormone secretion, *Endocr Rev* 18:678, 1997.
40. **Medhamurthy R, Dichek HL, Plant TM, Bernardini I, Cutler GB Jr**, Stimulation of gonadotropin secretion in prepubertal monkeys after hypothalamic excitation with aspartate and glutamate, *J Clin Endocrinol Metab* 71:1390, 1990.
41. **Plant TM, Gay VL, Marshall GR, Arslan M**, Puberty in monkeys is triggered by chemical stimulation of the hypothalamus, *Proc Natl Acad Sci U S A* 86:2506, 1989.
42. **Popa SM, Clifton DK, Steiner RA**, The role of kisspeptins and GPR54 in the neuroendocrine regulation of reproduction, *Annu Rev Physiol* 70:213, 2008.

43. **de Roux N, Genin E, Carel JC, Matsuda F, Chaussain JL, Milgrom E**, Hypogonadotropic hypogonadism due to loss of function of the KiSS1-derived peptide receptor GPR54, *Proc Natl Acad Sci U S A* 100:10972, 2003.
44. **Seminara SB, Messenger S, Chatzidaki EE, Thresher RR, Acierno JS Jr, Shagoury JK, Bo-Abbas Y, Kuohung W, Schwinof KM, Hendrick AG, Zahn D, Dixon J, Kaiser UB, Slaughaupt SA, Gusella JF, O'Rahilly S, Carlton MB, Crowley WF Jr, Aparicio SA, Colledge WH**, The GPR54 gene as a regulator of puberty, *N Engl J Med* 349:1614, 2003.
45. **Shahab M, Mastronardi C, Seminara SB, Crowley WF, Ojeda SR, Plant TM**, Increased hypothalamic GPR54 signaling: a potential mechanism for initiation of puberty in primates, *Proc Natl Acad Sci U S A* 102:2129, 2005.
46. **Rometo AM, Krajewski SJ, Voytko ML, Rance NE**, Hypertrophy and increased kisspeptin gene expression in the hypothalamic infundibular nucleus of postmenopausal women and ovariectomized monkeys, *J Clin Endocrinol Metab* 92:2744, 2007.
47. **Wakabayashi Y, Nakada T, Murata K, Ohkura S, Mogi K, Navarro VM, Clifton DK, Mori Y, Tsukamura H, Maeda K, Steiner RA, Okamura H**, Neurokinin B and dynorphin A in kisspeptin neurons of the arcuate nucleus participate in generation of periodic oscillation of neural activity driving pulsatile gonadotropin-releasing hormone secretion in the goat, *J Neurosci* 30(8):3124, 2010.
48. **Plant TM, Ramaswamy S, DiPietro MJ**, Repetitive activation of hypothalamic G protein-coupled receptor 54 with intravenous pulses of kisspeptin in the juvenile monkey (*Macaca mulatta*) elicits a sustained train of gonadotropin-releasing hormone discharges, *Endocrinology* 147:1007, 2006.
49. **Keen KL, Wegner FH, Bloom SR, Ghatgei MA, Terasawa E**, An increase in kisspeptin-54 release occurs with the pubertal increase in luteinizing hormone-releasing hormone-1 release in the stalk-median eminence of female rhesus monkeys in vivo, *Endocrinology* 149:4151, 2008.
50. **Tenenbaum-Rakover Y, Commenges-Ducos M, Iovane A, Aumas C, Admoni O, de Roux N**, Neuroendocrine phenotype analysis in five patients with isolated hypogonadotropic hypogonadism due to a L102P inactivating mutation of GPR54, *J Clin Endocrinol Metab* 92:1137, 2007.
51. **Seminara SB, DiPietro MJ, Ramaswamy S, Crowley WF Jr, Plant TM**, Continuous human metastin 45–54 infusion desensitizes G protein-coupled receptor 54-induced gonadotropin-releasing hormone release monitored indirectly in the juvenile male Rhesus monkey (*Macaca mulatta*): a finding with therapeutic implications, *Endocrinology* 147:2122, 2006.
52. **Ramaswamy S, Seminara SB, Pohl CR, DiPietro MJ, Crowley WF Jr, Plant TM**, Effect of continuous intravenous administration of human metastin 45–54 on the neuroendocrine activity of the hypothalamic-pituitary-testicular axis in the adult male rhesus monkey (*Macaca mulatta*), *Endocrinology* 148:3364, 2007.
53. **Teles MG, Bianco SD, Brito VN, Trarbach EB, Kuohung W, Xu S, Seminara SB, Mendonca BB, Kaiser UB, Latronico AC**, A GPR54-activating mutation in a patient with central precocious puberty, *N Engl J Med* 358:709, 2008.
54. **Semple RK, Achermann JC, Ellery J, Farooqi IS, Karet FE, Stanhope RG, O'Rahilly S, Aparicio SA**, Two novel missense mutations in g protein-coupled receptor 54 in a patient with hypogonadotropic hypogonadism, *J Clin Endocrinol Metab* 90:1849, 2005.
55. **Plant TM**, Gonadal regulation of hypothalamic gonadotropin-releasing hormone release in primates, *Endocr Rev* 7:75, 1986.
56. **Shibata M, Friedman RL, Ramaswamy S, Plant TM**, Evidence that down regulation of hypothalamic KiSS-1 expression is involved in the negative feedback action of testosterone to regulate luteinising hormone secretion in the adult male rhesus monkey (*Macaca mulatta*), *J Neuroendocrinol* 19:432, 2007.
57. **El Majdoubi M, Sahu A, Plant TM**, Changes in hypothalamic gene expression associated with the arrest of pulsatile gonadotropin-releasing hormone release during infancy in the gonadal male rhesus monkey (*Macaca mulatta*), *Endocrinology* 141:3273, 2000.
58. **Plant TM, Ramaswamy S**, Kisspeptin and the regulation of the hypothalamic-pituitary-gonadal axis in the rhesus monkey (*Macaca mulatta*), *Peptides* 30:67, 2009.
59. **Frisch R, Revelle R**, Variation in body weights and the age of the adolescent growth spurt among Latin

- American and Asian populations, in relation to calorie supplies, *Hum Biol* 41:185, 1969.
60. **Frisch RE, Revelle R, Cook S**, Components of weight at menarche and the initiation of the adolescent growth spurt in girls: estimated total water, lean body weight and fat, *Hum Biol* 45:469, 1973.
  61. **Rosenfield RL, Lipton RB, Drum ML**, Thelarche, pubarche, and menarche attainment in children with normal and elevated body mass index, *Pediatrics* 123:84, 2009.
  62. **Vigersky RA, Andersen AE, Thompson RH, Loriaux DL**, Hypothalamic dysfunction in secondary amenorrhea associated with simple weight loss, *N Engl J Med* 297:1141, 1977.
  63. **Dubey AK, Cameron JL, Steiner RA, Plant TM**, Inhibition of gonadotropin secretion in castrated male rhesus monkeys (*Macaca mulatta*) induced by dietary restriction: analogy with the prepubertal hiatus of gonadotropin release, *Endocrinology* 118:518, 1986.
  64. **Simon D**, Puberty in chronically diseased patients, *Horm Res* 57(Suppl 2):53, 2002.
  65. **I'Anson H, Manning JM, Herbosa CG, Pelt J, Friedman CR, Wood RI, Bucholtz DC, Foster DL**, Central inhibition of gonadotropin-releasing hormone secretion in the growth-restricted hypogonadotropic female sheep, *Endocrinology* 141:520, 2000.
  66. **Ahima RS, Prabakaran D, Mantzoros C, Qu D, Lowell B, Maratos-Flier E, Flier JS**, Role of leptin in the neuroendocrine response to fasting, *Nature* 382:250, 1996.
  67. **Zuure WA, Roberta AL, Quennell JH, Anderson GM**, Leptin signaling in GABA neurons, but not glutamate neurons, is required for reproductive function, *J Neurosci* 33:45, 2013.
  68. **Martin C, Navarro VM, Simavli S, Vong L, Carroll RS, Lowell BB, Kaiser UB**, Leptin-responsive GABAergic neurons regulate fertility through pathways that results in reduced kisspeptinergic tone, *J Neurosci* 34:17, 2014.
  69. **Mantzoros CS, Flier JS, Rogol AD**, A longitudinal assessment of hormonal and physical alterations during normal puberty in boys. V. Rising leptin levels may signal the onset of puberty, *J Clin Endocrinol Metab* 82:1066, 1997.
  70. **Roemmich JN, Rogol AD**, Role of leptin during childhood growth and development, *Endocrinol Metab Clin North Am* 28:749, 1999.
  71. **Roemmich JN, Clark PA, Berr SS, Mai V, Mantzoros CS, Flier JS, Weltman A, Rogol AD**, Gender differences in leptin levels during puberty are related to the subcutaneous fat depot and sex steroids, *Am J Physiol* 275:E543, 1998.
  72. **Matkovic V, Ilich JZ, Skugor M, Badenhop NE, Goel P, Clairmont A, Klisovic D, Nahhas RW, Landoll JD**, Leptin is inversely related to age at menarche in human females, *J Clin Endocrinol Metab* 82:1066, 1997.
  73. **Farooqi IS, Jebb SA, Langmack G, Lawrence E, Cheetham CH, Prentice AM, Hughes IA, McCamish MA, O'Rahilly S**, Effects of recombinant leptin therapy in a child with congenital leptin deficiency, *N Engl J Med* 341:879, 1999.
  74. **Farooqi IS**, Leptin and the onset of puberty: insights from rodent and human genetics, *Semin Reprod Med* 20:139, 2002.
  75. **Garcia MC, Lopez M, Alvarez CV, Casanueva F, Tena-Sempere M, Dieguez C**, Role of ghrelin in reproduction, *Reproduction* 133:531, 2007.
  76. **Gottsch ML, Clifton DK, Steiner RA**, Galanin-like peptide as a link in the integration of metabolism and reproduction, *Trends Endocrinol Metab* 15:215, 2004.
  77. **Terasawa E, Fernandez DL**, Neurobiological mechanisms of the onset of puberty in primates, *Endocr Rev* 22:111, 2001.
  78. **Roa J, Navarro VM, Tena-Sempere M**, Kisspeptins in reproductive biology: consensus knowledge and recent developments, *Biol Reprod* 85(4):650, 2011.
  79. **Korth-Schutz S, Levine LS, New MI**, Dehydroepiandrosterone sulfate (DS) levels, a rapid test for abnormal adrenal androgen secretion, *J Clin Endocrinol Metab* 42:1005, 1976.
  80. **de Peretti E, Forest MG**, Pattern of plasma dehydroepiandrosterone sulfate levels in humans from birth to adulthood: evidence for testicular production, *J Clin Endocrinol Metab* 47:572, 1978.
  81. **Ibanez L, Dimartino-Nardi J, Potau N, Saenger P**, Premature adrenarche—normal variant or forerunner of

adult disease? *Endocr Rev* 21:671, 2000.

82. **Rich BH, Rosenfield RL, Lucky AW, Helke JC, Otto P**, Adrenarche: changing adrenal response to adrenocorticotropin, *J Clin Endocrinol Metab* 52:1129, 1981.
83. **Endoh A, Kristiansen SB, Casson PR, Buster JE, Hornsby PJ**, The zona reticularis is the site of biosynthesis of dehydroepiandrosterone and dehydroepiandrosterone sulfate in the adult human adrenal cortex resulting from its low expression of 3 beta-hydroxysteroid dehydrogenase, *J Clin Endocrinol Metab* 81:3558, 1996.
84. **Hammer GD, Parker KL, Schimmer BP**, Minireview: transcriptional regulation of adrenocortical development, *Endocrinology* 146:1018, 2005.
85. **Gell JS, Carr BR, Sasano H, Atkins B, Margraf L, Mason JI, Rainey WE**, Adrenarche results from development of a 3beta-hydroxysteroid dehydrogenase-deficient adrenal reticularis, *J Clin Endocrinol Metab* 83:3695, 1998.
86. **Auchus RJ, Rainey WE**, Adrenarche - physiology, biochemistry and human disease, *Clin Endocrinol (Oxf)* 60:288, 2004.
87. **Huang N, Dardis A, Miller WL**, Regulation of cytochrome b5 gene transcription by Sp3, GATA-6, and steroidogenic factor 1 in human adrenal NCI-H295A cells, *Mol Endocrinol* 19:2020, 2005.
88. **Zumoff B, Walsh BT, Katz JL**, Subnormal plasma dehydroiso-androsterone to cortisol ratio in anorexia nervosa: a second hormonal parameter of ontogenetic regression, *J Clin Endocrinol Metab* 56:668, 1983.
89. **Parker LN**, Adrenarche, *Endocrinol Metab Clin North Am* 20:71, 1991.
90. **Taha D, Mullis PE, Ibanez L, de Zegher F**, Absent or delayed adrenarche in Pit-1/POU1F1 deficiency, *Horm Res* 64:175, 2005.
91. **Hauffa BP, Kaplan SL, Grumbach MM**, Dissociation between plasma adrenal androgens and cortisol in Cushing's disease and ectopic ACTH producing tumor: relation to adrenarche, *Lancet* 1:1373, 1984.
92. **Cavallo A**, Melatonin secretion during adrenarche in normal human puberty and in pubertal disorders, *J Pineal Res* 12:71, 1992.
93. **Ehrhart-Bornstein M, Hinson JP, Bornstein SR, Scherbaum WA, Vinson GP**, Intraadrenal interactions in the regulation of adrenocortical steroidogenesis, *Endocr Rev* 19:101, 1998.
94. **Smith CP, Dunger DB, Williams AJ, Taylor AM, Perry LA, Gale EA, Preece MA, Savage MO**, Relationship between insulin, insulin-like growth factor I, and dehydroepiandrosterone sulfate concentrations during childhood, puberty, and adult life, *J Clin Endocrinol Metab* 68:932, 1989.
95. **Blogowska A, Rzepka-Gorska I, Krzyzanowska-Swiniarska B**, Body composition, dehydroepiandrosterone sulfate and leptin concentrations in girls approaching menarche, *J Pediatr Endocrinol Metab* 18:975, 2005.
96. **Biason-Lauber A, Zachmann M, Schoenle EJ**, Effect of leptin on CYP17 enzymatic activities in human adrenal cells: new insight in the onset of adrenarche, *Endocrinology* 141:1446, 2000.
97. **Guercio G, Rivarola MA, Chaler E, Maceiras M, Belgorosky A**, Relationship between the growth hormone/insulin-like growth factor-I axis, insulin sensitivity, and adrenal androgens in normal prepubertal and pubertal girls, *J Clin Endocrinol Metab* 88:1389, 2003.
98. **Rosenfield RL**, Hirsutism and the variable response of the pilosebaceous unit to androgen, *J Investig Dermatol Symp Proc* 10:205, 2005.
99. **Remer T, Boye KR, Hartmann M, Neu CM, Schoenau E, Manz F, Wudy SA**, Adrenarche and bone modeling and remodeling at the proximal radius: weak androgens make stronger cortical bone in healthy children, *J Bone Miner Res* 18:1539, 2003.
100. **Abbassi V**, Growth and normal puberty, *Pediatrics* 102:507, 1998.
101. **Bass S, Delmas PD, Pearce G, Hendrich E, Tabensky A, Seeman E**, The differing tempo of growth in bone size, mass, and density in girls is region-specific, *J Clin Invest* 104:795, 1999.
102. **Biro FM, Huang B, Crawford PB, Lucky AW, Striegel-Moore R, Barton BA, Daniels S**, Pubertal correlates in black and white girls, *J Pediatr* 148:234, 2006.
103. **Tanner JM, Davies PS**, Clinical longitudinal standards for height and height velocity for North American children, *J Pediatr* 107:317, 1985.



104. **Lloyd T, Rollings N, Andon MB, Demers LM, Eggli DF, Kieselhorst K, Kulin H, Landis JR, Martel JK, Orr G**, Determinants of bone density in young women. I. Relationships among pubertal development, total body bone mass, and total body bone density in premenarchal females, *J Clin Endocrinol Metab* 75:383, 1992.
105. **Magarey AM, Boulton TJ, Chatterton BE, Schultz C, Nordin BE, Cockington RA**, Bone growth from 11 to 17 years: relationship to growth, gender and changes with pubertal status including timing of menarche, *Acta Paediatr* 88:139, 1999.
106. **Taranger J, Engstrom I, Lichtenstein H, Svennberg-Redegren I**, VI. Somatic pubertal development, *Acta Paediatr Scand Suppl* 258:121, 1976.
107. **McKay HA, Bailey DA, Mirwald RL, Davison KS, Faulkner RA**, Peak bone mineral accrual and age at menarche in adolescent girls: a 6-year longitudinal study, *J Pediatr* 133:682, 1998.
108. **Gilsanz V, Roe TF, Mora S, Costin G, Goodman WG**, Changes in vertebral bone density in black girls and white girls during childhood and puberty, *N Engl J Med* 325:1597, 1991.
109. **Maynard LM, Wisemandle W, Roche AF, Chumlea WC, Guo SS, Siervogel RM**, Childhood body composition in relation to body mass index, *Pediatrics* 107:344, 2001.
110. **Rosner B, Prineas R, Loggie J, Daniels SR**, Percentiles for body mass index in U.S. children 5 to 17 years of age, *J Pediatr* 132:211, 1998.
111. **Herrington J, Carter-Su C**, Signaling pathways activated by the growth hormone receptor, *Trends Endocrinol Metab* 12:252, 2001.
112. **Kojima M, Hosoda H, Date Y, Nakazato M, Matsuo H, Kangawa K**, Ghrelin is a growth-hormone-releasing acylated peptide from stomach, *Nature* 402:656, 1999.
113. **Shimon I, Taylor JE, Dong JZ, Bitonte RA, Kim S, Morgan B, Coy DH, Culler MD, Melmed S**, Somatostatin receptor subtype specificity in human fetal pituitary cultures. Differential role of SSTR2 and SSTR5 for growth hormone, thyroid-stimulating hormone, and prolactin regulation, *J Clin Invest* 99:789, 1997.
114. **Hartman ML, Veldhuis JD, Thorner MO**, Normal control of growth hormone secretion, *Horm Res* 40:37, 1993.
115. **Leung KC, Ho KK**, Measurement of growth hormone, insulin-like growth factor I and their binding proteins: the clinical aspects, *Clin Chim Acta* 313:119, 2001.
116. **Ho Y, Liebhaber SA, Cooke NE**, Activation of the human GH gene cluster: roles for targeted chromatin modification, *Trends Endocrinol Metab* 15:40, 2004.
117. **Giustina A, Veldhuis JD**, Pathophysiology of the neuroregulation of growth hormone secretion in experimental animals and the human, *Endocr Rev* 19:717, 1998.
118. **Jaffe CA, DeMott-Friberg R, Barkan AL**, Endogenous growth hormone (GH)-releasing hormone is required for GH responses to pharmacological stimuli, *J Clin Invest* 97:934, 1996.
119. **Unger RH**, The hyperleptinemia of obesity-regulator of caloric surpluses, *Cell* 117:145, 2004.
120. **Toogood AA, Nass RM, Pezzoli SS, O'Neill PA, Thorner MO, Shalet SM**, Preservation of growth hormone pulsatility despite pituitary pathology, surgery, and irradiation, *J Clin Endocrinol Metab* 82:2215, 1997.
121. **Hindmarsh PC, Matthews DR, Stratton I, Pringle PJ, Brook CDG**, Rate of change (modulation) of serum growth hormone concentrations is a more important factor in determining growth rate than duration of exposure, *Clin Endocrinol (Oxf)* 36:165, 1992.
122. **Savage MO, Burren CP, Blair JC, Woods KA, Metherell L, Clark AJ, Camacho-Hubner C**, Growth hormone insensitivity: pathophysiology, diagnosis, clinical variation and future perspectives, *Horm Res* 55(Suppl 2):32, 2001.
123. **De Meyts P, Whittaker J**, Structural biology of insulin and IGF1 receptors: implications for drug design, *Nat Rev Drug Discov* 1:769, 2002.
124. **Murphy LJ**, The role of the insulin-like growth factors and their binding proteins in glucose homeostasis, *Exp Diabetes Res* 4:213, 2003.
125. **Juul A**, Serum levels of insulin-like growth factor I and its binding proteins in health and disease, *Growth Horm IGF Res* 13:113, 2003.
126. **Harris DA, Van Vliet G, Egli CA, Grumbach MM, Kaplan SL, Styne DM, Vainsel M**, Somatomedin-C in normal puberty and in true precocious puberty before and after treatment with a potent luteinizing hormone-

releasing hormone agonist, *J Clin Endocrinol Metab* 61:152, 1985.

127. **Mansfield MJ, Rudlin CR, Crigler JF Jr, Karol KA, Crawford JD, Boepple PA, Crowley WF Jr**, Changes in growth and serum growth hormone and plasma somatomedin-C levels during suppression of gonadal sex steroid secretion in girls with central precocious puberty, *J Clin Endocrinol Metab* 66:3, 1988.
128. **Attie KM, Ramirez NR, Conte FA, Kaplan SL, Grumbach MM**, The pubertal growth spurt in eight patients with true precocious puberty and growth hormone deficiency: evidence for a direct role of sex steroids, *J Clin Endocrinol Metab* 71:975, 1990.
129. **Ross JL, Long LM, Skerda M, Cassorla F, Kurtz D, Loriaux DL, Cutler GB Jr**, Effect of low doses of estradiol on 6-month growth rates and predicted height in patients with Turner syndrome, *J Pediatr* 109:950, 1986.
130. **Bohnet HG**, New aspects of oestrogen/gestagen-induced growth and endocrine changes in individuals with Turner syndrome, *Eur J Pediatr* 145:275, 1986.
131. **He C, Kraft P, Chen C, Buring JE, Pare G, Hankinson SE, Chanock SJ, Ridker PM, Hunter DJ, Chasman DI**, Genome-wide association studies identify loci associated with age at menarche and age at natural menopause, *Nat Genet* 41(6):724, 2009.
132. **Perry JR, Stolk L, Franceschini N, Lunetta KL, Zhai G, McArdle PF, Smith AV, Aspelund T, Bandinelli S, Boerwinkle E, Cherkas L, Eiriksdottir G, Estrada K, Ferrucci L, Folsom AR, Garcia M, Gudnason V, Hofman A, Karasik D, Kiel DP, Launer LJ, van Meurs J, Nalls MA, Rivadeneira F, Shuldiner AR, Singleton A, Soranzo N, Tanaka T, Visser JA, Weedon MN, Wilson SG, Zhuang V, Streeten EA, Harris TB, Murray A, Spector TD, Demerath EW, Uitterlinden AG, Murabito JM**, Meta-analysis of genome-wide association data identifies two loci influencing age at menarche, *Nat Genet* 41(6):648, 2009.
133. **Viswanathan SR, Daley GQ, Gregory RI**, Selective blockade of microRNA processing by Lin28, *Science* 320:97, 2008.
134. **Sulem P, Gudbjartsson DF, Rafnar T, Holm H, Olafsdottir EJ, Olafsdottir GH, Jonsson T, Alexandersen P, Feenstra B, Boyd HA, Aben KK, Verbeek AL, Roeleveld N, Jonasdottir A, Styrkarsdottir U, Steinthorsdottir V, Karason A, Stacey SN, Gudmundsson J, Jakobsdottir M, Thorleifsson G, Hardarson G, Gulcher J, Kong A, Kiemenev LA, Melbye M, Christiansen C, Tryggvadottir L, Thorsteinsdottir U, Stefansson K**, Genome-wide association study identifies sequence variants on 6q21 associated with age at menarche, *Nat Genet* 41(6):734, 2009.
135. **Ong KK, Elks CE, Li S, Zhao JH, Luan J, Andersen LB, Bingham SA, Brage S, Smith GD, Ekelund U, Gillson CJ, Glaser B, Golding J, Hardy R, Khaw KT, Kuh D, Luben R, Marcus M, McGeehin MA, Ness AR, Northstone K, Ring SM, Rubin C, Sims MA, Song K, Strachan DP, Vollenweider P, Waeber G, Waterworth DM, Wong A, Deloukas P, Barroso I, Mooser V, Loos RJ, Wareham NJ**, Genetic variation in LIN28B is associated with the timing of puberty, *Nat Genet* 41(6):729, 2009.
136. **Tanner JM**, *Growth at Adolescence*. 2nd ed, Blackwell Scientific Publications, Oxford, 1962.
137. **Crain DA, Janssen SJ, Edwards TM, Heindel J, Ho SM, Hunt P, Iguchi T, Juul A, McLachlan JA, Schwartz J, Skakkebaek N, Soto AM, Swan S, Walker C, Woodruff TK, Woodruff TJ, Giudice LC, Guillette LJ Jr**, Female reproductive disorders: the roles of endocrine-disrupting compounds and developmental timing, *Fertil Steril* 90:911, 2008.
138. **Anderson SE, Dallal GE, Must A**, Relative weight and race influence average age at menarche: results from two nationally representative surveys of US girls studied 25 years apart, *Pediatrics* 111:844, 2003.
139. **Chumlea WC, Schubert CM, Roche AF, Kulin HE, Lee PA, Himes JH, Sun SS**, Age at menarche and racial comparisons in US girls, *Pediatrics* 111:110, 2003.
140. **Herman-Giddens ME, Slora EJ, Wasserman RC, Bourdony CJ, Bhapkar MV, Koch GG, Hasemeier CM**, Secondary sexual characteristics and menses in young girls seen in office practice: a study from the Pediatric Research in Office Settings network, *Pediatrics* 99:505, 1997.
141. **Sun SS, Schubert CM, Chumlea WC, Roche AF, Kulin HE, Lee PA, Himes JH, Ryan AS**, National estimates of the timing of sexual maturation and racial differences among US children, *Pediatrics* 110:911, 2002.

142. **Wu T, Mendola P, Buck GM**, Ethnic differences in the presence of secondary sex characteristics and menarche among US girls: the Third National Health and Nutrition Examination Survey, 1988–1994, *Pediatrics* 110:752, 2002.
143. **Anderson SE, Must A**, Interpreting the continued decline in the average age at menarche: results from two nationally representative surveys of U.S. girls studied 10 years apart, *J Pediatr* 147:753, 2005.
144. **Zacharias L, Wurtman RJ**, Age at menarche. Genetic and environmental influences, *N Engl J Med* 280:868, 1969.
145. **Kaplowitz PB, Slora EJ, Wasserman RC, Pedlow SE, Herman-Giddens ME**, Earlier onset of puberty in girls: relation to increased body mass index and race, *Pediatrics* 108:347, 2001.
146. **Adair LS, Gordon-Larsen P**, Maturation timing and overweight prevalence in US adolescent girls, *Am J Public Health* 91:642, 2001.
147. **Freedman DS, Khan LK, Serdula MK, Dietz WH, Srinivasan SR, Berenson GS**, Relation of age at menarche to race, time period, and anthropometric dimensions: the Bogalusa Heart Study, *Pediatrics* 110:e43, 2002.
148. **Johnston FE, Roche AF, Schell LM, Norman H, Wettenhall B**, Critical weight at menarche. Critique of a hypothesis, *Am J Dis Child* 129:19, 1975.
149. **Garn SM, LaVelle M, Rosenberg KR, Hawthorne VM**, Maturation timing as a factor in female fatness and obesity, *Am J Clin Nutr* 43:879, 1986.
150. **Biro FM, Lucky AW, Simbartl LA, Barton BA, Daniels SR, Striegel-Moore R, Kronsberg SS, Morrison JA**, Pubertal maturation in girls and the relationship to anthropometric changes: pathways through puberty, *J Pediatr* 142:643, 2003.
151. **Ma HM, Du ML, Luo XP, Chen SK, Liu L, Chen RM, Zhu C, Xiong F, Li T, Wang W, Liu GL**, Onset of breast and pubic hair development and menses in urban Chinese girls, *Pediatrics* 124:e269, 2009.
152. **Marshall WA, Tanner JM**, Variations in pattern of pubertal changes in girls, *Arch Dis Child* 44:291, 1969.
153. **Marshall WA, Tanner JM**, Variations in the pattern of pubertal changes in boys, *Arch Dis Child* 45:13, 1970.
154. **Read GF, Wilson DW, Hughes IA, Griffiths K**, The use of salivary progesterone assays in the assessment of ovarian function in postmenarcheal girls, *J Endocrinol* 102:265, 1984.
155. **Vuorento T, Huhtaniemi I**, Daily levels of salivary progesterone during menstrual cycle in adolescent girls, *Fertil Steril* 58:685, 1992.
156. **Apter D, Vihko R**, Early menarche, a risk factor for breast cancer, indicates early onset of ovulatory cycles, *J Clin Endocrinol Metab* 57:82, 1983.
157. **Sizonenko PC, Paunier L**, Hormonal changes in puberty III: correlation of plasma dehydroepiandrosterone, testosterone, FSH and LH with stage of puberty and bone age in normal boys and girls and in patients with Addison's disease or hypogonadism or premature or late adrenarche, *J Clin Endocrinol Metab* 41:894, 1975.
158. **Hung W, August GP, Glasgow AM**, *Pediatric Endocrinology*, Medical Examination Publishing Co., Garden City, 1978.
159. **Jenner MR, Kelch RP, Kaplan SL, Grumbach MM**, Hormonal changes in puberty. IV. Plasma estradiol, LH and FSH in prepubertal children, pubertal females, and in precocious puberty, premature thelarche, hypogonadism and in a child with a feminizing ovarian tumor, *J Clin Endocrinol Metab* 34:521, 1972.
160. **Raiti S, Johanson A, Light C, Migeon CJ, Blizzard RM**, Measurement of immunologically reactive follicle stimulating hormone in serum of normal male children and adults, *Metabolism* 18:234, 1969.
161. **Johanson J, Guyda H, Light C, Migeon CG, Blizzard RM**, Serum luteinizing hormone by radioimmunoassay in normal children, *J Pediatr* 74:416, 1969.
162. **Frasier SD, Gafford F, Horton R**, Plasma androgens and adolescence, *J Clin Endocrinol Metab* 29:1404, 1969.
163. **Lee PA, Migeon CJ**, Puberty in boys: correlation of plasma levels of gonadotropins (LH, FSH), androgens (testosterone, androstenedione, dehydroepiandrosterone and its sulfate), estrogens (estrone and estradiol) and progestins (progesterone and 17-hydroxyprogesterone), *J Clin Endocrinol Metab* 41:556, 1975.
164. **Bergstrom E, Hernell O, Lonnerdal B, Persson LA**, Sex differences in iron stores of adolescents: what is normal? *J Pediatr Gastroenterol Nutr* 20:215, 1995.

165. **Looker AC, Dallman PR, Carroll MD, Gunter EW, Johnson CL**, Prevalence of iron deficiency in the United States, *JAMA* 277:973, 1997.
166. **Lucky AW, Biro FM, Huster GA, Morrison JA, Elder N**, Acne vulgaris in early adolescent boys. Correlations with pubertal maturation and age, *Arch Dermatol* 127:210, 1991.
167. **Lucky AW, Biro FM, Simbartl LA, Morrison JA, Sorg NW**, Predictors of severity of acne vulgaris in young adolescent girls: results of a five-year longitudinal study, *J Pediatr* 130:30, 1997.
168. **Angold A, Worthman CW**, Puberty onset of gender differences in rates of depression: a developmental, epidemiologic and neuroendocrine perspective, *J Affect Disord* 29:145, 1993.
169. **Brown KM, McMahon RP, Biro FM, Crawford P, Schreiber GB, Similo SL, Waclawiw M, Striegel-Moore R**, Changes in self-esteem in black and white girls between the ages of 9 and 14 years. The NHLBI Growth and Health Study, *J Adolesc Health* 23:7, 1998.
170. **Striegel-Moore RH, McMahon RP, Biro FM, Schreiber G, Crawford PB, Voorhees C**, Exploring the relationship between timing of menarche and eating disorder symptoms in Black and White adolescent girls, *Int J Eat Disord* 30:421, 2001.
171. **Graber JA, Lewinsohn PM, Seeley JR, Brooks-Gunn J**, Is psychopathology associated with the timing of pubertal development? *J Am Acad Child Adolesc Psychiatry* 36:1768, 1997.
172. **Magnusson D, Stattin H, Allen V**, Differential maturation among girls and its relation to social adjustment: a longitudinal perspective, In: Featerman D, Lerner R, eds. *Life-Span Development and Behavior*, Academic Press, New York, 1986, p. 135.
173. **Ge X, Conger RD, Elder GH Jr**, Coming of age too early: pubertal influences on girls' vulnerability to psychological distress, *Child Dev* 67:3386, 1996.
174. **Gevelber MA, Biro FM**, Adolescents and sexually transmitted diseases, *Pediatr Clin North Am* 46:747, 1999.
175. **Rosenthal SL, Biro FM, Succop PA, Bernstein DI, Stanberry LR**, Impact of demographics, sexual history, and psychological functioning on the acquisition of STDS in adolescents, *Adolescence* 32:757, 1997.
176. **Harrison HR, Costin M, Meder JB, Bownds LM, Sim DA, Lewis M, Alexander ER**, Cervical Chlamydia trachomatis infection in university women: relationship to history, contraception, ectopy, and cervicitis, *Am J Obstet Gynecol* 153:244, 1985.
177. **Moscicki AB, Winkler B, Irwin CE Jr, Schachter J**, Differences in biologic maturation, sexual behavior, and sexually transmitted disease between adolescents with and without cervical intraepithelial neoplasia, *J Pediatr* 115:487, 1989.
178. **Shew ML, Fortenberry JD, Miles P, Amortegui AJ**, Interval between menarche and first sexual intercourse, related to risk of human papillomavirus infection, *J Pediatr* 125:661, 1994.
179. **Kaplowitz PB, Oberfield SE**, Reexamination of the age limit for defining when puberty is precocious in girls in the United States: implications for evaluation and treatment. Drug and Therapeutics and Executive Committees of the Lawson Wilkins Pediatric Endocrine Society, *Pediatrics* 104:936, 1999.
180. **Finlay F, Jones R**, Precocious puberty, *Pediatrics* 106:162, 2000.
181. **Rosenfield RL, Bachrach LK, Chernausk SD, Gertner JM, Gottschalk M, Hardin DS, Pescovitz OH, Saenger P**, Current age of onset of puberty, *Pediatrics* 106:622, 2000.
182. **Stanhope R**, Gonadotrophin-dependent precocious puberty and occult intracranial tumors: which girls should have neuro-imaging? *J Pediatr* 143:426, 2003.
183. **Midyett LK, Moore WV, Jacobson JD**, Are pubertal changes in girls before age 8 benign? *Pediatrics* 111:47, 2003.
184. **Chalumeau M, Chemaitilly W, Trivin C, Adan L, Breart G, Brauner R**, Central precocious puberty in girls: an evidence-based diagnosis tree to predict central nervous system abnormalities, *Pediatrics* 109:61, 2002.
185. **Chalumeau M, Hadjiathanasiou CG, Ng SM, Cassio A, Mul D, Cisternino M, Partsch CJ, Theodoridis C, Didi M, Cacciari E, Oostdijk W, Borghesi A, Sippell WG, Breart G, Brauner R**, Selecting girls with precocious puberty for brain imaging: validation of European evidence-based diagnosis rule, *J Pediatr* 143:445, 2003.
186. **Kaplowitz P**, Precocious puberty in girls and the risk of a central nervous system abnormality: the elusive

search for diagnostic certainty, *Pediatrics* 109:139, 2002.

187. **Biro FM, Galvez MP, Greenspan LC, Succop PA, Vangeepuram N, Pinney SM, Teitelbaum S, Windham GC, Kushi LH, Wolff MS**, Pubertal assessment method and baseline characteristics in a mixed longitudinal study of girls, *Pediatrics* 126:e583, 2010.
188. **Kaplowitz P, Bloch C**; the **Section on Endocrinology**, Evaluation and referral of children with signs of early puberty, *Pediatrics* 137:e20153732, 2016.
189. **Pescovitz OH, Comite F, Hench K, Barnes K, McNemar A, Foster C, Kenigsberg D, Loriaux DL, Cutler GB Jr**, The NIH experience with precocious puberty: diagnostic subgroups and response to short-term luteinizing hormone releasing hormone analogue therapy, *J Pediatr* 108:47, 1986.
190. **Bridges NA, Christopher JA, Hindmarsh PC, Brook CG**, Sexual precocity: sex incidence and aetiology, *Arch Dis Child* 70:116, 1994.
191. **Chemaitilly W, Trivin C, Adan L, Gall V, Sainte-Rose C, Brauner R**, Central precocious puberty: clinical and laboratory features, *Clin Endocrinol (Oxf)* 54:289, 2001.
192. **Ng SM, Kumar Y, Cody D, Smith CS, Didi M**, Cranial MRI scans are indicated in all girls with central precocious puberty, *Arch Dis Child* 88:414, 2003.
193. **Mahachoklertwattana P, Kaplan SL, Grumbach MM**, The luteinizing hormone-releasing hormone-secreting hypothalamic hamartoma is a congenital malformation: natural history, *J Clin Endocrinol Metab* 77:118, 1993.
194. **Striano S, Meo R, Bilo L, Cirillo S, Nocerino C, Ruosi P, Striano P, Estraneo A**, Gelastic epilepsy: symptomatic and cryptogenic cases, *Epilepsia* 40:294, 1999.
195. **Jung H, Carmel P, Schwartz MS, Witkin JW, Bentele KH, Westphal M, Piatt JH, Costa ME, Cornea A, Ma YJ, Ojeda SR**, Some hypothalamic hamartomas contain transforming growth factor alpha, a puberty-inducing growth factor, but not luteinizing hormone-releasing hormone neurons, *J Clin Endocrinol Metab* 84:4695, 1999.
196. **Listernick R, Charrow J, Gutmann DH**, Intracranial gliomas in neurofibromatosis type 1, *Am J Med Genet* 89:38, 1999.
197. **Pescovitz OH, Hench K, Green O, Comite F, Loriaux DL, Cutler GB Jr**, Central precocious puberty complicating a virilizing adrenal tumor: treatment with a long-acting LHRH analog, *J Pediatr* 106:612, 1985.
198. **Pescovitz OH, Cassorla F, Comite F, Loriaux DL, Cutler GB Jr**, LHRH analog treatment of central precocious puberty complicating congenital adrenal hyperplasia, *Ann N Y Acad Sci* 458:174, 1985.
199. **Holland FJ, Kirsch SE, Selby R**, Gonadotropin-independent precocious puberty ("testotoxicosis"): influence of maturational status on response to ketoconazole, *J Clin Endocrinol Metab* 64:328, 1987.
200. **Anasti JN, Flack MR, Froehlich J, Nelson LM, Nisula BC**, A potential novel mechanism for precocious puberty in juvenile hypothyroidism, *J Clin Endocrinol Metab* 80:276, 1995.
201. **Faggiano M, Criscuolo T, Perrone L, Quarto C, Sinisi AA**, Sexual precocity in a boy due to hypersecretion of LH and prolactin by a pituitary adenoma, *Acta Endocrinol (Copenh)* 102:167, 1983.
202. **Ambrosi B, Bassetti M, Ferrario R, Medri G, Giannattasio G, Faglia G**, Precocious puberty in a boy with a PRL-, LH- and FSH-secreting pituitary tumour: hormonal and immunocytochemical studies, *Acta Endocrinol (Copenh)* 122:569, 1990.
203. **Rodriguez-Macias KA, Thibaud E, Houang M, Duflos C, Beldjord C, Rappaport R**, Follow up of precocious pseudopuberty associated with isolated ovarian follicular cysts, *Arch Dis Child* 81:53, 1999.
204. **de Sousa G, Wunsch R, Andler W**, Precocious pseudopuberty due to autonomous ovarian cysts: a report of ten cases and long-term follow-up, *Hormones (Athens)* 7:170, 2008.
205. **Pienkowski C, Baunin C, Gayrard M, Lemasson F, Vayasse P, Tauber M**, Ovarian cysts in prepubertal girls, In: Sultan C, ed. *Pediatric and Adolescent Gynecology. Evidence-Based Clinical Practice*, Karger, Basel, 2004, p. 66.
206. **Fakhry J, Khoury A, Kotval PS, Noto RA**, Sonography of autonomous follicular ovarian cysts in precocious pseudopuberty, *J Ultrasound Med* 7:597, 1988.
207. **Lack EE, Perez-Atayde AR, Murthy AS, Goldstein DP, Crigler JF Jr, Vawter GF**, Granulosa theca cell tumors in premenarchal girls: a clinical and pathologic study of ten cases, *Cancer* 48:1846, 1981.

208. **Young RH, Dickersin GR, Scully RE**, Juvenile granulosa cell tumor of the ovary. A clinicopathological analysis of 125 cases, *Am J Surg Pathol* 8:575, 1984.
209. **Arhan E, Cetinkaya E, Aycan Z, Aslan AT, Yucel H, Vidinlisan S**, A very rare cause of virilization in childhood: ovarian Leydig cell tumor, *J Pediatr Endocrinol Metab* 21:181, 2008.
210. **Weinstein LS, Shenker A, Gejman PV, Merino MJ, Friedman E, Spiegel AM**, Activating mutations of the stimulatory G protein in the McCune-Albright syndrome, *N Engl J Med* 325:1688, 1991.
211. **Shenker A, Weinstein LS, Moran A, Pescovitz OH, Charest NJ, Boney CM, Van Wyk JJ, Merino MJ, Feuillan PP, Spiegel AM**, Severe endocrine and nonendocrine manifestations of the McCune-Albright syndrome associated with activating mutations of stimulatory G protein GS, *J Pediatr* 123:509, 1993.
212. **Lumbroso S, Paris F, Sultan C**, Activating G $\alpha$  mutations: analysis of 113 patients with signs of McCune-Albright syndrome—a European Collaborative Study, *J Clin Endocrinol Metab* 89:2107, 2004.
213. **de Sanctis C, Lala R, Matarazzo P, Balsamo A, Bergamaschi R, Cappa M, Cisternino M, de Sanctis V, Lucci M, Franzese A, Ghizzoni L, Pasquino AM, Segni M, Rigon F, Saggese G, Bertelloni S, Buzi F**, McCune-Albright syndrome: a longitudinal clinical study of 32 patients, *J Pediatr Endocrinol Metab* 12:817, 1999.
214. **Haddad N, Eugster E**, An update on the treatment of precocious puberty in McCune-Albright syndrome and testotoxicosis, *J Pediatr Endocrinol Metab* 20:653, 2007.
215. **Frisch LS, Copeland KC, Boepple PA**, Recurrent ovarian cysts in childhood: diagnosis of McCune-Albright syndrome by bone scan, *Pediatrics* 90:102, 1992.
216. **Massart F, Parrino R, Seppia P, Federico G, Saggese G**, How do environmental estrogen disruptors induce precocious puberty? *Minerva Pediatr* 58:247, 2006.
217. **Donovan M, Tiwary CM, Axelrod D, Sasco AJ, Jones L, Hajek R, Sauber E, Kuo J, Davis DL**, Personal care products that contain estrogens or xenoestrogens may increase breast cancer risk, *Med Hypotheses* 68:756, 2007.
218. **Massart F, Meucci V, Saggese G, Soldani G**, High growth rate of girls with precocious puberty exposed to estrogenic mycotoxins, *J Pediatr* 152:690, 2008.
219. **McLachlan JA, Simpson E, Martin M**, Endocrine disrupters and female reproductive health, *Best Pract Res Clin Endocrinol Metab* 20:63, 2006.
220. **Aksglaede L, Juul A, Leffers H, Skakkebaek NE, Andersson AM**, The sensitivity of the child to sex steroids: possible impact of exogenous estrogens, *Hum Reprod Update* 12:341, 2006.
221. **Rosenfield RL, Cooke DW, Radovick S**, The ovary and female maturation, In: Sperling M, ed. *Pediatric Endocrinology*, Elsevier, Philadelphia, 2008, p. 530.
222. **Ibanez L, Jimenez R, de Zegher F**, Early puberty-menarche after precocious pubarche: relation to prenatal growth, *Pediatrics* 117:117, 2006.
223. **Saenger P**, Premature adrenarche, In: Fineberg L, Kleinman R, eds. *Saunders Manual of Pediatric Practice*, WB Saunders, Philadelphia, 2002, p. 933.
224. **Rosenfield RL**, Clinical review: identifying children at risk for polycystic ovary syndrome, *J Clin Endocrinol Metab* 92:787, 2007.
225. **Utriainen P, Jaaskelainen J, Romppanen J, Voutilainen R**, Childhood metabolic syndrome and its components in premature adrenarche, *J Clin Endocrinol Metab* 92:4282, 2007.
226. **Vuguin P, Linder B, Rosenfeld RG, Saenger P, DiMartino-Nardi J**, The roles of insulin sensitivity, insulin-like growth factor I (IGF-I), and IGF-binding protein-1 and -3 in the hyperandrogenism of African-American and Caribbean Hispanic girls with premature adrenarche, *J Clin Endocrinol Metab* 84:2037, 1999.
227. **Ibanez L, Potau N, Zampolli M, Rique S, Saenger P, Carrascosa A**, Hyperinsulinemia and decreased insulin-like growth factor-binding protein-1 are common features in prepubertal and pubertal girls with a history of premature pubarche, *J Clin Endocrinol Metab* 82:2283, 1997.
228. **Ibanez L, Potau N, Chacon P, Pascual C, Carrascosa A**, Hyperinsulinaemia, dyslipaemia and cardiovascular risk in girls with a history of premature pubarche, *Diabetologia* 41:1057, 1998.
229. **Denburg MR, Silfen ME, Manibo AM, Chin D, Levine LS, Ferin M, McMahan DJ, Go C, Oberfield SE**, Insulin sensitivity and the insulin-like growth factor system in prepubertal boys with premature adrenarche,

J Clin Endocrinol Metab 87:5604, 2002.

230. **Ibanez L, Valls C, Potau N, Marcos MV, de Zegher F**, Sensitization to insulin in adolescent girls to normalize hirsutism, hyperandrogenism, oligomenorrhea, dyslipidemia, and hyperinsulinism after precocious pubarche, *J Clin Endocrinol Metab* 85:3526, 2000.
231. **Ibanez L, Valls C, Ferrer A, Marcos MV, Rodriguez-Hierro F, de Zegher F**, Sensitization to insulin induces ovulation in nonobese adolescents with anovulatory hyperandrogenism, *J Clin Endocrinol Metab* 86:3595, 2001.
232. **Lappalainen S, Utriainen P, Kuulasmaa T, Voutilainen R, Jääskeläinen J**, Androgen receptor gene CAG repeat polymorphism and X-chromosome inactivation in children with premature adrenarche, *J Clin Endocrinol Metab* 93(4):1304, 2008.
233. **Vottero A, Capelletti M, Giuliodori S, Viani I, Ziveri M, Ner TM, Bernasconi S, Chizzoni L**, Decreased androgen receptor gene methylation in premature pubarche: a novel pathogenic mechanism? *J Clin Endocrinol Metab* 91(3):968, 2006.
234. **Rosenfield RL, Lucky AW**, Acne, hirsutism, and alopecia in adolescent girls. Clinical expressions of androgen excess, *Endocrinol Metab Clin North Am* 22:507, 1993.
235. **Lutfallah C, Wang W, Mason JI, Chang YT, Haider A, Rich B, Castro-Magana M, Copeland KC, David R, Pang S**, Newly proposed hormonal criteria via genotypic proof for type II 3beta-hydroxysteroid dehydrogenase deficiency, *J Clin Endocrinol Metab* 87:2611, 2002.
236. **Sherar LB, Mirwald RL, Baxter-Jones AD, Thomis M**, Prediction of adult height using maturity-based cumulative height velocity curves, *J Pediatr* 147:508, 2005.
237. **New MI**, Steroid 21-hydroxylase deficiency (congenital adrenal hyperplasia), *Am J Med* 98:2S, 1995.
238. **Mills JL, Stolley PD, Davies J, Moshang T Jr**, Premature thelarche. Natural history and etiologic investigation, *Am J Dis Child* 135:743, 1981.
239. **Chellakooty M, Schmidt IM, Haavisto AM, Boisen KA, Damgaard IN, Mau C, Petersen JH, Juul A, Skakkebaek NE, Main KM**, Inhibin A, inhibin B, follicle-stimulating hormone, luteinizing hormone, estradiol, and sex hormone-binding globulin levels in 473 healthy infant girls, *J Clin Endocrinol Metab* 88:3515, 2003.
240. **Codner E, Roman R**, Premature thelarche from phenotype to genotype, *Pediatr Endocrinol Rev* 5:760, 2008.
241. **Ilicki A, Prager Lewin R, Kauli R, Kaufman H, Schachter A, Laron Z**, Premature thelarche—natural history and sex hormone secretion in 68 girls, *Acta Paediatr Scand* 73:756, 1984.
242. **Van Winter JT, Noller KL, Zimmerman D, Melton LJ**, Natural history of premature thelarche in Olmsted County, Minnesota 1940 to 1984, *J Pediatr* 116:278, 1990.
243. **Verrotti A, Ferrari M, Morgese G, Chiarelli F**, Premature thelarche: a long-term follow-up, *Gynecol Endocrinol* 10:241, 1996.
244. **Volta C, Bernasconi S, Cisternino M, Buzi F, Ferzetti A, Street ME, Da Milano AM**, Isolated premature thelarche and thelarche variant: clinical and auxological follow-up of 119 girls, *J Endocrinol Invest* 21:180, 1998.
245. **Salardi S, Cacciari E, Mainetti B, Mazzanti L, Pirazzoli P**, Outcome of premature thelarche: relation to puberty and final height, *Arch Dis Child* 79:173, 1998.
246. **Garibaldi LR, Aceto T Jr, Weber C**, The pattern of gonadotropin and estradiol secretion in exaggerated thelarche, *Acta Endocrinol (Copenh)* 128:345, 1993.
247. **Pescovitz OH, Hench KD, Barnes KM, Loriaux DL, Cutler GB Jr**, Premature thelarche and central precocious puberty: the relationship between clinical presentation and the gonadotropin response to luteinizing hormone-releasing hormone, *J Clin Endocrinol Metab* 67:474, 1988.
248. **Roman R, Johnson MC, Codner E, Boric MA, áVila A, Cassorla F**, Activating GNAS1 gene mutations in patients with premature thelarche, *J Pediatr* 145:218, 2004.
249. **Pasquino AM, Pucarelli I, Passeri F, Segni M, Mancini MA, Municchi G**, Progression of premature thelarche to central precocious puberty, *J Pediatr* 126:11, 1995.
250. **Zhu SY, Du ML, Huang TT**, An analysis of predictive factors for the conversion from premature thelarche into complete central precocious puberty, *J Pediatr Endocrinol Metab* 21:533, 2008.
251. **Papadimitriou A, Beri D, Tsialla A, Fretzayas A, Psychou F, Nicolaidou P**, Early growth acceleration in

- girls with idiopathic precocious puberty, *J Pediatr* 149:43, 2006.
252. **Neely EK, Hintz RL, Wilson DM, Lee PA, Gautier T, Argente J, Stene M**, Normal ranges for immunochemiluminometric gonadotropin assays, *J Pediatr* 127:40, 1995.
  253. **Neely EK, Wilson DM, Lee PA, Stene M, Hintz RL**, Spontaneous serum gonadotropin concentrations in the evaluation of precocious puberty, *J Pediatr* 127:47, 1995.
  254. **Resende EA, Lara BH, Reis JD, Ferreira BP, Pereira GA, Borges MF**, Assessment of basal and gonadotropin-releasing hormone-stimulated gonadotropins by immunochemiluminometric and immunofluorometric assays in normal children, *J Clin Endocrinol Metab* 92:1424, 2007.
  255. **Garibaldi LR, Aceto T Jr, Weber C, Pang S**, The relationship between luteinizing hormone and estradiol secretion in female precocious puberty: evaluation by sensitive gonadotropin assays and the leuprolide stimulation test, *J Clin Endocrinol Metab* 76:851, 1993.
  256. **Ibanez L, Potau N, Zampolli M, Virdis R, Gussinye M, Carrascosa A, Saenger P, Vicens-Calvet E**, Use of leuprolide acetate response patterns in the early diagnosis of pubertal disorders: comparison with the gonadotropin-releasing hormone test, *J Clin Endocrinol Metab* 78:30, 1994.
  257. **Carel JC, Eugster EA, Rogol A, Ghizzoni L, Palmert MR, Antoniazzi F, Berenbaum S, Bourguignon JP, Chrousos GP, Coste J, Deal S, de Vries L, Foster C, Heger S, Holland J, Jahnukainen K, Juul A, Kaplowitz P, Lahlou N, Lee MM, Lee P, Merke DP, Neely EK, Oostdijk W, Phillip M, Rosenfield RL, Shulman D, Styne D, Tauber M, Wit JM**, Consensus statement on the use of gonadotropin-releasing hormone analogs in children, *Pediatrics* 123:e752, 2009.
  258. **Brito VN, Batista MC, Borges MF, Latronico AC, Kohek MB, Thirone AC, Jorge BH, Arnhold IJ, Mendonca BB**, Diagnostic value of fluorometric assays in the evaluation of precocious puberty, *J Clin Endocrinol Metab* 84:3539, 1999.
  259. **Carel JC, Leger J**, Clinical practice. Precocious puberty, *N Engl J Med* 358:2366, 2008.
  260. **Comite F, Cutler GB Jr, Rivier J, Vale WW, Loriaux DL, Crowley WF Jr**, Short-term treatment of idiopathic precocious puberty with a long-acting analogue of luteinizing hormone-releasing hormone. A preliminary report, *N Engl J Med* 305:1546, 1981.
  261. **Crowley WF Jr, Comite F, Vale W, Rivier J, Loriaux DL, Cutler GB Jr**, Therapeutic use of pituitary desensitization with a long-acting LHRH agonist: a potential new treatment for idiopathic precocious puberty, *J Clin Endocrinol Metab* 52:370, 1981.
  262. **Comite F, Cassorla F, Barnes KM, Hench KD, Dwyer A, Skerda MC, Loriaux DL, Cutler GB Jr, Pescovitz OH**, Luteinizing hormone releasing hormone analogue therapy for central precocious puberty. Long-term effect on somatic growth, bone maturation, and predicted height, *JAMA* 255:2613, 1986.
  263. **Rosenfield RL**, Selection of children with precocious puberty for treatment with gonadotropin releasing hormone analogs, *J Pediatr* 124:989, 1994.
  264. **Klein KO, Barnes KM, Jones JV, Feuillan PP, Cutler GB Jr**, Increased final height in precocious puberty after long-term treatment with LHRH agonists: the National Institutes of Health experience, *J Clin Endocrinol Metab* 86:4711, 2001.
  265. **Pasquino AM, Pucarelli I, Segni M, Matrunola M, Cerroni F**, Adult height in girls with central precocious puberty treated with gonadotropin-releasing hormone analogues and growth hormone, *J Clin Endocrinol Metab* 84:449, 1999.
  266. **Walvoord EC, Pescovitz OH**, Combined use of growth hormone and gonadotropin-releasing hormone analogues in precocious puberty: theoretic and practical considerations, *Pediatrics* 104:1010, 1999.
  267. **Tanaka T, Niimi H, Matsuo N, Fujieda K, Tachibana K, Ohyama K, Satoh M, Kugu K**, Results of long-term follow-up after treatment of central precocious puberty with leuprorelin acetate: evaluation of effectiveness of treatment and recovery of gonadal function. The TAP-144-SR Japanese Study Group on Central Precocious Puberty, *J Clin Endocrinol Metab* 90:1371, 2005.
  268. **Bar A, Linder B, Sobel EH, Saenger P, DiMartino-Nardi J**, Bayley-Pinneau method of height prediction in girls with central precocious puberty: correlation with adult height, *J Pediatr* 126:955, 1995.
  269. **Palmert MR, Malin HV, Boepple PA**, Unsustained or slowly progressive puberty in young girls: initial presentation and long-term follow-up of 20 untreated patients, *J Clin Endocrinol Metab* 84:415, 1999.



270. **Fontoura M, Brauner R, Prevot C, Rappaport R**, Precocious puberty in girls: early diagnosis of a slowly progressing variant, *Arch Dis Child* 64:1170, 1989.
271. **Antoniazzi F, Zamboni G**, Central precocious puberty: current treatment options, *Paediatr Drugs* 6:211, 2004.
272. **Lahlou N, Carel JC, Chaussain JL, Roger M**, Pharmacokinetics and pharmacodynamics of GnRH agonists: clinical implications in pediatrics, *J Pediatr Endocrinol Metab* 13(Suppl 1):723, 2000.
273. **Partsch CJ, Sippell WG**, Treatment of central precocious puberty, *Best Pract Res Clin Endocrinol Metab* 16:165, 2002.
274. **Partsch CJ, Hummelink R, Peter M, Sippell WG, Oostdijk W, Odink RJ, Drop SL**, Comparison of complete and incomplete suppression of pituitary-gonadal activity in girls with central precocious puberty: influence on growth and predicted final height. The German-Dutch Precocious Puberty Study Group, *Horm Res* 39:111, 1993.
275. **Lee PA**, Central precocious puberty. An overview of diagnosis, treatment, and outcome, *Endocrinol Metab Clin North Am* 28:901, 1999.
276. **Bhatia S, Neely EK, Wilson DM**, Serum luteinizing hormone rises within minutes after depot leuprolide injection: implications for monitoring therapy, *Pediatrics* 109:E30, 2002.
277. **Wierman ME, Beardsworth DE, Crawford JD, Crigler JF Jr, Mansfield MJ, Bode HH, Boepple PA, Kushner DC, Crowley WF Jr**, Adrenarche and skeletal maturation during luteinizing hormone releasing hormone analogue suppression of gonadarche, *J Clin Invest* 77:121, 1986.
278. **Cassio A, Bal MO, Orsini LF, Balsamo A, Sansavini S, Gennari M, De Cristofaro E, Cicognani A**, Reproductive outcome in patients treated and not treated for idiopathic early puberty: long-term results of a randomized trial in adults, *J Pediatr* 149:532, 2006.
279. **Jay N, Mansfield MJ, Blizzard RM, Crowley WF Jr, Schoenfeld D, Rhubin L, Boepple PA**, Ovulation and menstrual function of adolescent girls with central precocious puberty after therapy with gonadotropin-releasing hormone agonists, *J Clin Endocrinol Metab* 75:890, 1992.
280. **Stewart L, Steinbok P, Daaboul J**, Role of surgical resection in the treatment of hypothalamic hamartomas causing precocious puberty. Report of six cases, *J Neurosurg* 88:340, 1998.
281. **Nunez SB, Calis K, Cutler GB Jr, Jones J, Feuillan PP**, Lack of efficacy of fadrozole in treating precocious puberty in girls with the McCune-Albright syndrome, *J Clin Endocrinol Metab* 88:5730, 2003.
282. **Feuillan P, Calis K, Hill S, Shawker T, Robey PG, Collins MT**, Letrozole treatment of precocious puberty in girls with the McCune-Albright syndrome: a pilot study, *J Clin Endocrinol Metab* 92:2100, 2007.
283. **Shulman DI, Francis GL, Palmert MR, Eugster EA**, Use of aromatase inhibitors in children and adolescents with disorders of growth and adolescent development, *Pediatrics* 121:e975, 2008.
284. **Mieszczak J, Lowe ES, Plourde P, Eugster EA**, The aromatase inhibitor anastrozole is ineffective in the treatment of precocious puberty in girls with McCune-Albright syndrome, *J Clin Endocrinol Metab* 93:2751, 2008.
285. **Eugster EA, Rubin SD, Reiter EO, Plourde P, Jou HC, Pescovitz OH**, Tamoxifen treatment for precocious puberty in McCune-Albright syndrome: a multicenter trial, *J Pediatr* 143:60, 2003.
286. **Lala R, Matarazzo P, Bertelloni S, Buzi F, Rigon F, de Sanctis C**, Pamidronate treatment of bone fibrous dysplasia in nine children with McCune-Albright syndrome, *Acta Paediatr* 89:188, 2000.
287. **Reindollar RH, Tho SPT, McDonough PG**, Delayed puberty: an updated study of 326 patients, *Trans Am Gynecol Obstet Soc* 8:146, 1989.
288. **Sedlmeyer IL, Palmert MR**, Delayed puberty: analysis of a large case series from an academic center, *J Clin Endocrinol Metab* 87:1613, 2002.
289. **Rosenfield RL**, Clinical review 6: diagnosis and management of delayed puberty, *J Clin Endocrinol Metab* 70:559, 1990.
290. **Pugliese MT, Lifshitz F, Grad G, Fort P, Marks-Katz M**, Fear of obesity. A cause of short stature and delayed puberty, *N Engl J Med* 309:513, 1983.
291. **Wilson DA, Hofman PL, Miles HL, Unwin KE, McGrail CE, Cutfield WS**, Evaluation of the busserelin stimulation test in diagnosing gonadotropin deficiency in males with delayed puberty, *J Pediatr* 148:89, 2006.
292. **Ghai K, Cara JF, Rosenfield RL**, Gonadotropin releasing hormone agonist (nafarelin) test to differentiate

- gonadotropin deficiency from constitutionally delayed puberty in teen-age boys—a clinical research center study, *J Clin Endocrinol Metab* 80:2980, 1995.
293. **Kauschansky A, Dickerman Z, Phillip M, Weintrob N, Strich D**, Use of GnRH agonist and human chorionic gonadotrophin tests for differentiating constitutional delayed puberty from gonadotrophin deficiency in boys, *Clin Endocrinol (Oxf)* 56:603, 2002.
  294. **Tommaselli AP, Valentino R, Savastano S, Randazzo G, Scalfi L, Contaldo F, Dorato M, Lombardi G**, Altered glycosylation of pituitary gonadotropins in anorexia nervosa: an alternative explanation for amenorrhea, *Eur J Endocrinol* 132:450, 1995.
  295. **Copeland KC, Paunier L, Sizonenko PC**, The secretion of adrenal androgens and growth patterns of patients with hypogonadotropic hypogonadism and idiopathic delayed puberty, *J Pediatr* 91:985, 1977.
  296. **Karlberg J**, A biologically-oriented mathematical model (ICP) for human growth, *Acta Paediatr Scand Suppl* 350:70, 1989.
  297. **Kerrigan JR, Rogol AD**, The impact of gonadal steroid hormone action on growth hormone secretion during childhood and adolescence, *Endocr Rev* 13:281, 1992.
  298. **Tanner JM, Goldstein H, Whitehouse RH**, Standards for children's height at ages 2–9 years allowing for heights of parents, *Arch Dis Child* 45:755, 1970.
  299. **Bayley N, Pinneau SR**, Tables for predicting adult height from skeletal age: revised for use with the Greulich-Pyle hand standards, *J Pediatr* 40:423, 1952.
  300. **Kauli R, Galatzer A, Kornreich L, Lazar L, Pertzalan A, Laron Z**, Final height of girls with central precocious puberty, untreated versus treated with cyproterone acetate or GnRH analogue. A comparative study with re-evaluation of predictions by the Bayley-Pinneau method, *Horm Res* 47:54, 1997.
  301. **Rosenfeld RG, Albertsson-Wikland K, Cassorla F, Frasier SD, Hasegawa Y, Hintz RL, Lafranchi S, Lippe B, Loriaux L, Melmed S**, Diagnostic controversy: the diagnosis of childhood growth hormone deficiency revisited, *J Clin Endocrinol Metab* 80:1532, 1995.
  302. **Damen GM, Boersma B, Wit JM, Heymans HS**, Catch-up growth in 60 children with celiac disease, *J Pediatr Gastroenterol Nutr* 19:394, 1994.
  303. **Brain CE, Savage MO**, Growth and puberty in chronic inflammatory bowel disease, *Baillieres Clin Gastroenterol* 8:83, 1994.
  304. **Balfour-Lynn L**, Growth and childhood asthma, *Arch Dis Child* 61:1049, 1986.
  305. **Betts PR, Magrath G**, Growth pattern and dietary intake of children with chronic renal insufficiency, *Br Med J* 2:189, 1974.
  306. **Rappold GA, Fukami M, Niesler B, Schiller S, Zumkeller W, Bettendorf M, Heinrich U, Vlachopapadopoulou E, Reinehr T, Onigata K, Ogata T**, Deletions of the homeobox gene SHOX (short stature homeobox) are an important cause of growth failure in children with short stature, *J Clin Endocrinol Metab* 87:1402, 2002.
  307. **Huber C, Rosilio M, Munnich A, Cormier-Daire V**, High incidence of SHOX anomalies in individuals with short stature, *J Med Genet* 43:735, 2006.
  308. **Ross JL, Kowal K, Quigley CA, Blum WF, Cutler GB Jr, Crowe B, Hovanes K, Elder FF, Zinn AR**, The phenotype of short stature homeobox gene (SHOX) deficiency in childhood: contrasting children with Leri-Weill dyschondrosteosis and Turner syndrome, *J Pediatr* 147:499, 2005.
  309. **Rappold G, Blum WF, Shavrikova EP, Crowe BJ, Roeth R, Quigley CA, Ross JL, Niesler B**, Genotypes and phenotypes in children with short stature: clinical indicators of SHOX haploinsufficiency, *J Med Genet* 44:306, 2007.
  310. **Kang MJ**, Novel genetic cause of idiopathic short stature, *Ann Pediatr Endocrinol Metab* 22(3), 2017.
  311. **Leschek EW, Rose SR, Yanovski JA, Troendle JF, Quigley CA, Chipman JJ, Crowe BJ, Ross JL, Cassorla FG, Blum WF, Cutler GB Jr, Baron J**, Effect of growth hormone treatment on adult height in peripubertal children with idiopathic short stature: a randomized, double-blind, placebo-controlled trial, *J Clin Endocrinol Metab* 89:3140, 2004.
  312. **Hintz RL, Attie KM, Baptista J, Roche A**, Effect of growth hormone treatment on adult height of children with idiopathic short stature. Genentech Collaborative Group, *N Engl J Med* 340:502, 1999.

313. **Finkelstein BS, Imperiale TF, Speroff T, Marrero U, Radcliffe DJ, Cuttler L**, Effect of growth hormone therapy on height in children with idiopathic short stature: a meta-analysis, *Arch Pediatr Adolesc Med* 156:230, 2002.
314. **Bryant J, Baxter L, Cave CB, Milne R**, Recombinant growth hormone for idiopathic short stature in children and adolescents, *Cochrane Database Syst Rev* (3):CD004440, 2007.
315. **Downie AB, Mulligan J, McCaughey ES, Stratford RJ, Betts PR, Voss LD**, Psychological response to growth hormone treatment in short normal children, *Arch Dis Child* 75:32, 1996.
316. **Theunissen NC, Kamp GA, Koopman HM, Zwinderman KA, Vogels T, Wit JM**, Quality of life and self-esteem in children treated for idiopathic short stature, *J Pediatr* 140:507, 2002.
317. **Visser-van Balen H, Geenen R, Kamp GA, Huisman J, Wit JM, Sinnema G**, Long-term psychosocial consequences of hormone treatment for short stature, *Acta Paediatr* 96:715, 2007.
318. **Rekers-Mombarg LT, Wit JM, Massa GG, Ranke MB, Buckler JM, Butenandt O, Chaussain JL, Frisch H, Leiberman E**, Spontaneous growth in idiopathic short stature. European Study Group, *Arch Dis Child* 75:175, 1996.
319. **Cohen P, Rogol AD, Deal CL, Saenger P, Reiter EO, Ross JL, Chernausek SD, Savage MO, Wit JM**, Consensus statement on the diagnosis and treatment of children with idiopathic short stature: a summary of the Growth Hormone Research Society, the Lawson Wilkins Pediatric Endocrine Society, and the European Society for Paediatric Endocrinology Workshop, *J Clin Endocrinol Metab* 93:4210, 2008.
320. **Kemp SF, Kuntze J, Attie KM, Maneatis T, Butler S, Frane J, Lippe B**, Efficacy and safety results of long-term growth hormone treatment of idiopathic short stature, *J Clin Endocrinol Metab* 90:5247, 2005.
321. **Kamp GA, Waelkens JJ, de Muinck Keizer-Schrama SM, Delemarre-Vandewaal HA, Verhoeven-Wind L, Zwinderman AH, Wit JM**, High dose growth hormone treatment induces acceleration of skeletal maturation and an earlier onset of puberty in children with idiopathic short stature, *Arch Dis Child* 87:215, 2002.
322. **Crowe BJ, Rekers-Mombarg LT, Robling K, Wolka AM, Cutler GB Jr, Wit JM**, Effect of growth hormone dose on bone maturation and puberty in children with idiopathic short stature, *J Clin Endocrinol Metab* 91:169, 2006.
323. **Sandberg DE, Bukowski WM, Fung CM, Noll RB**, Height and social adjustment: are extremes a cause for concern and action? *Pediatrics* 114:744, 2004.
324. **Allen DB, Fost N**, hGH for short stature: ethical issues raised by expanded access, *J Pediatr* 144:648, 2004.
325. **Lee JM, Davis MM, Clark SJ, Hofer TP, Kemper AR**, Estimated cost-effectiveness of growth hormone therapy for idiopathic short stature, *Arch Pediatr Adolesc Med* 160:263, 2006.
326. **Yanovski JA, Rose SR, Municchi G, Pescovitz OH, Hill SC, Cassorla FG, Cutler GB Jr**, Treatment with a luteinizing hormone-releasing hormone agonist in adolescents with short stature, *N Engl J Med* 348:908, 2003.
327. **Drop SL, De Waal WJ, De Muinck Keizer-Schrama SM**, Sex steroid treatment of constitutionally tall stature, *Endocr Rev* 19:540, 1998.
328. **Sotos JF**, Overgrowth. Hormonal Causes, *Clin Pediatr (Phila)* 35:579, 1996.
329. **Schlesinger S, MacGillivray MH, Munschauer RW**, Acceleration of growth and bone maturation in childhood thyrotoxicosis, *J Pediatr* 83:233, 1973.
330. **Smith EP, Boyd J, Frank GR, Takahashi H, Cohen RM, Specker B, Williams TC, Lubahn DB, Korach KS**, Estrogen resistance caused by a mutation in the estrogen-receptor gene in a man, *N Engl J Med* 331:1056, 1994.
331. **Morishima A, Grumbach MM, Simpson ER, Fisher C, Qin K**, Aromatase deficiency in male and female siblings caused by a novel mutation and the physiological role of estrogens, *J Clin Endocrinol Metab* 80:3689, 1995.
332. **Thistlethwaite D, Darling JA, Fraser R, Mason PA, Rees LH, Harkness RA**, Familial glucocorticoid deficiency. Studies of diagnosis and pathogenesis, *Arch Dis Child* 50:291, 1975.
333. **Malchoff CD, Javier EC, Malchoff DM, Martin T, Rogol A, Brandon D, Loriaux DL, Reardon GE**, Primary cortisol resistance presenting as isosexual precocity, *J Clin Endocrinol Metab* 70:503, 1990.
334. **Huseman C, Johanson A, Varma M, Blizzard RM**, Congenital lipodystrophy: an endocrine study in three

- siblings. I. Disorders of carbohydrate metabolism, *J Pediatr* 93:221, 1978.
335. **Hayward C, Porteous ME, Brock DJ**, Mutation screening of all 65 exons of the fibrillin-1 gene in 60 patients with Marfan syndrome: report of 12 novel mutations, *Hum Mutat* 10:280, 1997.
  336. **Fowler B, Jakobs C**, Post- and prenatal diagnostic methods for the homocystinurias, *Eur J Pediatr* 157(Suppl 2):S88, 1998.
  337. **Carmi D, Shohat M, Metzker A, Dickerman Z**, Growth, puberty, and endocrine functions in patients with sporadic or familial neurofibromatosis type 1: a longitudinal study, *Pediatrics* 103:1257, 1999.
  338. **Joss EE, Temperli R, Mullis PE**, Adult height in constitutionally tall stature: accuracy of five different height prediction methods, *Arch Dis Child* 67:1357, 1992.
  339. **Wettenhall HN, Cahill C, Roche AF**, Tall girls: a survey of 15 years of management and treatment, *J Pediatr* 86:602, 1975.
  340. **Prader A, Zachmann M**, Treatment of excessively tall girls and boys with sex hormones, *Pediatrics* 62:1202, 1978.
  341. **Bailey JD, Park E, Cowell C**, Estrogen treatment of girls and constitutional tall stature, *Pediatr Clin North Am* 28:501, 1981.
  342. **Bierich JR**, Estrogen treatment of girls with constitutional tall stature, *Pediatrics* 62:1196, 1978.
  343. **Sorgo W, Scholler K, Heinze F, Heinze E, Teller WM**, Critical analysis of height reduction in oestrogen-treated tall girls, *Eur J Pediatr* 142:260, 1984.
  344. **Schoen EJ, Solomon IL, Warner O, Wingerd J**, Estrogen treatment of tall girls, *Am J Dis Child* 125:71, 1973.
  345. **Norman H, Wettenhall B, Cahill C, Roche AF**, Tall girls: a survey of 15 years of management and treatment, *Adolesc Med* 86:602, 1975.
  346. **de Waal WJ, Greyn-Fokker MH, Stijnen T, van Gurp EA, Toolens AM, de Munick Keizer-Schrama SM, Aarsen RS, Drop SL**, Accuracy of final height prediction and effect of growth-reductive therapy in 362 constitutionally tall children, *J Clin Endocrinol Metab* 81:1206, 1996.
  347. **de Waal WJ, Torn M, de Muinck Keizer-Schrama SM, Aarsen RS, Drop SL**, Long term sequelae of sex steroid treatment in the management of constitutionally tall stature, *Arch Dis Child* 73:311, 1995.
  348. **Venn A, Bruinsma F, Werther G, Pyett P, Baird D, Jones P, Rayner J, Lumley J**, Oestrogen treatment to reduce the adult height of tall girls: long-term effects on fertility, *Lancet* 364:1513, 2004.
  349. **Hendriks AE, Drop SL, Laven JS, Boot AM**, Fertility of tall girls treated with high-dose estrogen, a dose-response relationship, *J Clin Endocrinol Metab* 97(9), 2012.
  350. **Hendriks AE, Laven JS, Valkenburg O, Fong SL, Fauser BC, de Ridder MA, de Jong FH, Visser JA, van Ginneken AM, Boot AM, Drop SL**, Fertility and ovarian function in high-dose estrogen-treated tall women, *J Clin Endocrinol Metab* 96(4), 2011.

# Amenorrhea

Few problems in gynecologic endocrinology can present a diagnostic challenge to clinicians like that of amenorrhea. The number, variety, and complexity of diseases and disorders that must be considered can seem daunting and, in many instances, include unfamiliar organ systems. Moreover, some of the diagnostic possibilities can have serious consequences, if not recognized and treated effectively. Consequently, otherwise confident and experienced clinicians may view the problem as too complicated and time-consuming or may question their ability to perform or interpret the evaluation. However, when approached logically and systematically, the diagnostic evaluation of amenorrhea truly is straightforward, involving thorough history taking and a finite number of laboratory tests and procedures already familiar to almost all clinicians. With few exceptions, an evaluation can be completed quickly and without great expense.

The purpose of this chapter is to provide a systematic strategy for the evaluation of amenorrhea that will yield an accurate diagnosis, no matter how common or uncommon the cause. Once a diagnosis is established, additional corroborating evidence and the assistance of appropriate specialists (e.g., neurosurgeon, internist, endocrinologist, or psychiatrist) can be obtained, when necessary. However, the large majority of women with amenorrhea have relatively simple problems—polycystic ovary syndrome (PCOS), hypothalamic amenorrhea, hyperprolactinemia, and ovarian failure—all of which can be managed easily by the primary health providers after an initial consultation with a specialist.

The diagnostic evaluation described here is not new. With minor modifications, it has been applied successfully for several decades. Before describing the evaluation in detail, amenorrhea first must be defined, so as to identify the patients who warrant an evaluation. A brief preliminary review of the physiologic mechanisms involved in menstruation (discussed in detail in [Chapter 5](#)) provides the framework necessary to understand and follow the logical design of the diagnostic evaluation.

# DEFINITION OF AMENORRHEA

---

The age at which menarche should be expected varies with individual differences in the age at the onset of puberty. The normal pubertal progression is discussed in detail in [Chapter 9](#) and is only briefly summarized here. In general, the first menses should occur within 2–3 years after the initiation of pubertal development. In most young girls (approximately 80%), the first sign of puberty is an acceleration of growth (the growth spurt), followed by breast budding (thelarche) and the appearance of pubic hair (adrenarche). In the remainder (approximately 20%), adrenarche precedes thelarche by a brief interval, but the two events typically are closely linked. Consequently, menarche can occur as early as age 10 (when puberty begins at age 8) and rarely occurs later than age 16 (when puberty begins at age 13). On average, the mean ages for thelarche, adrenarche, and menarche in girls of African ancestry are 6–12 months earlier than in Caucasian girls. Once normal menstrual cycles have been established, menses should occur at regular intervals ranging between 25 and 35 days. The term amenorrhea refers to “absence of menses.” **Patients fulfilling any of the following criteria should be evaluated for amenorrhea:**

- **No menses by age 14 in the absence of growth or development of secondary sexual characteristics**
- **No menses by age 16 regardless of the presence of normal growth and development of secondary sexual characteristics**
- **In women who have menstruated previously, no menses for an interval of time equivalent to a total of at least three previous cycles or no menses over a 6-month period**

Having affirmed the traditional definition of amenorrhea, it is important to point out that unduly strict adherence to these criteria with a disregard to the overall clinical picture can result in a delay in identifying serious underlying health conditions. For example, there is no reason to defer the evaluation of a young girl who presents with the classical phenotype of Turner syndrome. Similarly, a 14-year-old girl who has no vagina should not be advised to return in 2 years before initiating evaluation and offering intervention. All patients deserve a considerate evaluation at initial presentation. Finally, the possibility of pregnancy as a reason for amenorrhea must always be considered.

Traditionally, amenorrhea has been categorized as primary or secondary. Primary amenorrhea describes patients who have never menstruated, and secondary amenorrhea describes those who have menstruated previously but now do not. The differential diagnoses of primary and secondary amenorrhea differ. For example, when evaluating a case of primary amenorrhea, the clinician must consider a wide range of possibilities;

these should include consideration of possible absence of hypothalamic gonadotropin-releasing hormone (GnRH) (such as in cases of Kallmann syndrome), disorders of the pituitary (ranging from hyperprolactinemia, secondary hypothyroidism to abnormalities in the secretion of growth hormone [GH] and gonadotropins), abnormalities of the ovaries that could range from gonadal dysgenesis to functional abnormalities such as PCOS, and abnormalities of the müllerian system that could range from complete absence of the uterus to various forms of obstructive anomalies such as imperforate hymen, transverse vaginal septum, or vaginal agenesis. In contrast, when encountering secondary amenorrhea, developmental absence of GnRH or presence of obstructive uterine anomalies of the müllerian system as a mechanism for amenorrhea is highly unlikely. While these classic distinctions between primary and secondary amenorrhea can help narrow the scope of diagnostic possibilities, such preliminary categorization can sometimes be misleading. For example, premature ovarian insufficiency (POI), PCOS, and pregnancy can present as either primary or secondary amenorrhea. In any case, the diagnostic approach recommended here can be applied effectively in all women with amenorrhea.

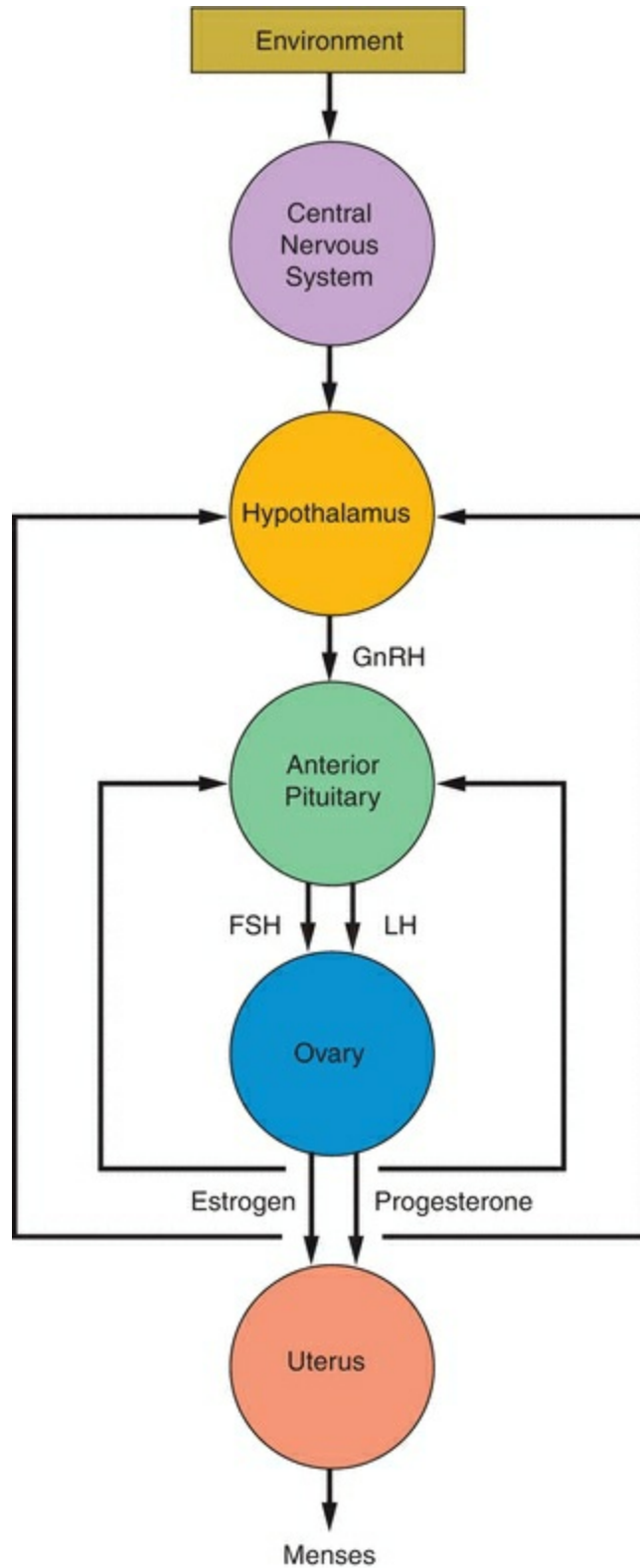
# BASIC PRINCIPLES IN MENSTRUAL FUNCTION

---

A functioning hypothalamo-pituitary-ovarian (HPO) axis along with a normal uterovaginal anatomy is a requisite for menstrual function. The ovaries must contain viable follicles that can respond to stimulation by the gonadotropins, follicle-stimulating hormone (FSH), and luteinizing hormone (LH), released from the anterior pituitary. In turn, pituitary gonadotropin secretion depends on the action of GnRH, secreted from the medial basal hypothalamus into the portal vascular network that bathes the anterior pituitary. Finally, the pulsatile pattern of hypothalamic GnRH secretion is governed by input from higher centers that interpret and translate environmental stimuli and modulated by the feedback effects of ovarian sex steroids. Finally, the uterus must contain a functional endometrium that can respond to the actions of ovarian sex steroid hormones, estrogen and progesterone, across the ovarian cycle of follicle development, ovulation, and corpus luteum function, and the genital outflow tract must be anatomically intact with continuous connection between the vaginal orifice, the vaginal canal, the endocervix, and the uterine cavity, to allow egress to the menstrual flow that marks the beginning of each menstrual cycle. The entire system is highly regulated by a complex interplay of mechanisms that integrate biophysical and biochemical information composed of interacting hormonal signals, autocrine/paracrine factors, and target cell reactions.

The basic requirements for normal menstrual function thus include four anatomically and functionally distinct structural components—(1) the genital outflow tract including the uterus, cervix, and vagina; (2) the ovary; (3) the pituitary; and (4) the hypothalamus—thus providing a natural and useful hierarchy for organizing the diagnostic evaluation of amenorrhea (**Figure 10.1**).





**FIGURE 10.1**

Therefore, the many causes of amenorrhea can be categorized according to the site or level of the disorder or disturbance:

- **Disorders of the genital outflow tract and uterus**
- **Disorders of the ovary**
- **Disorders of the anterior pituitary**
- **Disorders of the hypothalamus or central nervous system**

Amenorrhea can result from congenital or acquired disease or dysfunction at any level in the system and can involve more than one mechanism. For example, PCOS involves a number of interrelated pathophysiologic mechanisms operating at multiple levels including the ovarian, the pituitary, and the hypothalamus.

# EVALUATION OF AMENORRHEA

---

Like any other complaint, evaluation begins with a careful medical history followed by a detailed physical examination, which always provide valuable diagnostic clues. Information gained from the medical history and physical examination clearly can exclude certain differential diagnoses; however, hasty first impressions also can be deceiving and can lead to errors in judgment and to inappropriate, costly, and needless testing. A methodical, systematic approach to evaluation to help arrive at the most plausible diagnosis therefore is best.

Logically, the recommended evaluation for amenorrhea is designed to separate the reproductive physiology and function into its distinct structural components—the genital outflow tract and uterus, the ovary, the pituitary, and the hypothalamus—and to test the functional integrity of each, beginning at the lowest level and progressing systematically to the higher levels of the system until the cause is determined.

# Medical History

The menstrual history is, of course, key. Primary amenorrhea speaks for itself, but cyclic pelvic or lower abdominal pain or urinary complaints can be caused by developmental anomalies resulting in obstructed menstrual flow (cryptomenorrhea), such as may be caused by an imperforate hymen, transverse vaginal septum, or cervical atresia. In women with secondary amenorrhea, the history surrounding the onset of amenorrhea can provide important diagnostic clues. Onset of amenorrhea following endometrial curettage or other uterine surgery involving the endometrial cavity (e.g., resection of a submucous uterine fibroid) clearly suggests the possibility of damage to the endometrium as a mechanism for amenorrhea (e.g., Asherman syndrome resulting from endometrial curettage undertaken for removal of products of conception in management of a nonviable early pregnancy). Amenorrhea, either secondary or even primary, in the setting of symptoms of hyperandrogenism (acne, excess facial and bodily hair, or thinning of scalp hair) is highly suggestive of PCOS. Galactorrhea in the setting of amenorrhea identifies hyperprolactinemia, PCOS, or pregnancy as plausible mechanisms for amenorrhea. Women with PCOS classically present with infrequent and irregular menses dating from menarche or early adulthood and often report long-standing symptoms of hyperandrogenism. In most with hypothalamic amenorrhea, the onset of amenorrhea temporally relates to events resulting in severe nutritional, physical, or emotional stress. Picture of POI can vary with some women presenting as primary amenorrhea, others reporting varying durations of menstrual irregularity before amenorrhea, to sudden cessation of menses in the absence of any prior menstrual disturbances. While symptoms of hypoestrogenism, such as hot flashes and night sweats, are often experienced by women with POI presenting as secondary amenorrhea, these symptoms may not be experienced when POI develops prior to onset of puberty.

Questions relating to past medical history, general health, and lifestyle can identify a severe or chronic illness such as diabetes, renal failure (which is often associated with elevated prolactin levels, primarily reflective of altered renal clearance), or inflammatory bowel disease, previous head trauma, or evidence of physical or psychological stress. Specific history relating to weight loss or weight gain and to the frequency and intensity of exercise is highly relevant and often revealing. Headaches, seizures, vomiting, behavioral changes, or visual symptoms may suggest a disorder of the central nervous system. Vaginal dryness or hot flashes are evidence of estrogen deficiency and suggest ovarian insufficiency. Progressive hirsutism or features of virilization are unusual in PCOS and concerning for either nonclassical (late-onset) congenital adrenal hyperplasia (CAH) or an androgen-producing tumor of the ovary or adrenal gland; possibility of exposure to exogenous androgens as a mechanism for worsening hyperandrogenism must also be considered. Symptoms of galactorrhea obviously suggest hyperprolactinemia, but may require directed questioning as this

symptom may not be spontaneously divulged by some women. History relating to the time and duration of any treatment with oral contraceptive pills (OCP), progestins (e.g., depot medroxyprogesterone acetate [MPA], progestin implants, or intrauterine system), GnRH agonists (often used for management of common gynecologic disorders such as endometriosis, uterine fibroids, and premenstrual syndrome), or other medications or drugs that can affect central neurotransmitter secretion and thereby disrupt hypothalamo-pituitary signals that are critical to normal menstrual function (phenothiazines, reserpine derivatives, amphetamines, benzodiazepines, antidepressants, dopamine antagonists, opiates) also can provide important diagnostic clues. Pregnancy as a mechanism for amenorrhea must always be considered, regardless of patient's age.

# Physical Examination

The overall body habitus often provides important information. Height, weight, and body mass index (BMI) should be determined and recorded. A combination of sexual infantilism and short stature (<60 inches, or 152.4 cm) is a hallmark of gonadal dysgenesis. Hypothalamic amenorrhea is often seen in conditions associated with poor nutrition (eating disorders such as anorexia nervosa, malabsorption syndromes) or physical, psychological, or emotional stress. Obesity and an increased waist-hip ratio (>0.85) are commonly encountered in women with PCOS.

Both hypothyroidism and hyperthyroidism can be associated with amenorrhea. Examination of the skin can reveal a soft, warm, and moist texture as seen in hyperthyroidism; a rapid pulse, exophthalmos or lid lag, a fine tremor, and hyperreflexia suggest the diagnosis of Graves disease; goiter may not always be appreciated. Conversely, dry, coarse skin, a slow pulse, diminished reflexes, and thinning of the hair, particularly involving eyebrow hair, are suggestive of hypothyroidism. A goiter or thyroid nodule is further evidence of a thyroid disorder. Orange discoloration of the skin, without scleral icterus, can result from hypercarotenemia associated with excessive ingestion of low-calorie carotene-containing fruits and vegetables in chronically dieting women. Acanthosis nigricans (velvety hyperpigmented skin observed most commonly at the nape of the neck, in the axillae and groin, and beneath the breasts) strongly suggests severe insulin resistance, hyperinsulinemia, and the possibility of type II diabetes. Features of hyperandrogenism, such as acne and hirsutism, are common symptoms of PCOS, but can also be the presenting symptoms of nonclassical CAH, or result from exposure to androgenic anabolic steroids. When accompanied by any sign of frank virilization (deepening of the voice, frontotemporal balding, decrease in breast size, increased muscle mass, clitoromegaly), the possibility of ovarian hyperthecosis or an ovarian or adrenal neoplasm must be considered.

Examination of the breasts deserves careful attention. **Breast development is a reliable indicator of endogenous estrogen production or exposure to exogenous estrogens.** The Tanner stage of breast development should be noted ([Chapter 9](#)). A secondary arrest of breast development suggests a disruption of the HPO axis. When menarche has not followed breast development at the expected time (ideally, within 2 years of thelarche), a developmental anomaly of the reproductive tract as a mechanism for primary amenorrhea should be high in the list of differential diagnoses. Breast examination should be systematic and thorough yet gentle, and examination of the nipple must be undertaken to evaluate for expressible galactorrhea. **Secretions that result from hormonal stimulation of the breast tissue typically emerge from multiple duct openings at the nipple, whereas a discharge relating to breast pathology usually arises from a single duct.** Macroscopic characteristics of any expressed nipple

discharge can point to the underlying etiology; bilateral nipple discharge that appears milky or opaque is a classic manifestation of hyperprolactinemia; unilateral bloody or greenish discharge should raise concerns for a focal ductal pathology and should be further evaluated with imaging studies (mammography, ultrasound, or even breast MRI). Microscopic examination of any expressed cloudy or white nipple secretions demonstrating lipid droplets confirms galactorrhea and suggests hyperprolactinemia. Evidence of chronic chest wall lesion(s) (such as eczema) may even identify a mechanism for hyperprolactinemia.

Abdominal examination rarely may reveal a suprapubic mass, as may result from hematometra or an eccentric mass suggestive of an ovarian neoplasm. Excessive growth of terminal hair in the infraumbilical region and extension of pubic hair in a male escutcheon pattern are suggestive of hyperandrogenism. Purple hue abdominal striae raise the possibility of Cushing syndrome (discussed in [Chapter 13](#)); more commonly, however, pale pink stretch marks along the abdominal wall often result from progressive obesity or a previous pregnancy.

Careful examination of the external genitalia and the lower genital tract is key, particularly when evaluating for primary amenorrhea. **The presence of pubic hair growth reliably reflects androgen production or exposure.** Because breast development and growth of pubic hair typically progress in a symmetrical manner, their Tanner stages should be consistent. Absent or scant growth of sexual hair can be expected in otherwise sexually infantile girls, but also is a classical sign of androgen insensitivity syndrome (AIS) when breast development may be asymmetrically advanced. Clitoromegaly is a concerning sign of virilization and should prompt evaluation for hyperandrogenemia; obvious and severe enlargement of the clitoris may suggest ambiguous genitalia, and in this case, assessment of karyotype may be the next step in evaluation. Attempts at office examination of the vagina in sexually infantile girls or those with a small hymenal ring are generally non-informative and often even counterproductive; such an examination can be effectively undertaken under anesthesia, at which time either a speculum examination or vaginoscopy can be performed to document the presence and appearance of the cervix. A patent vagina and normal cervix exclude müllerian/vaginal agenesis, AIS, and obstructive causes of primary amenorrhea such as an imperforate hymen or a transverse vaginal septum. In those with primary amenorrhea having an absent or infantile vaginal orifice, rectal examination can provide meaningful information as a distended hematocolpos can be easily palpated proximal to the site of obstruction from a transverse vaginal septum, when the uterus is present and functional. Atrophic appearance of the external genitalia and loss of rugosity of the vaginal epithelium are features that would suggest a diagnosis of POI.

# Evaluation of the Genital Outflow Tract and Uterus

Evaluation of the genital outflow tract and uterus can be organized easily based on the menstrual history and physical examination of the genital anatomy. Primary amenorrhea in the setting of adequate development of secondary sex characteristics but with a blind or absent vagina points directly to a developmental anomaly of the genital outflow tract as a mechanism for amenorrhea. Primary or secondary amenorrhea with a patent vagina and visible cervix excludes abnormalities of the genital outflow tract, except in those with history of previous cervical or uterine surgery or infection in whom the possibilities of cervical stenosis and intrauterine adhesions or other endometrial damage must be considered.

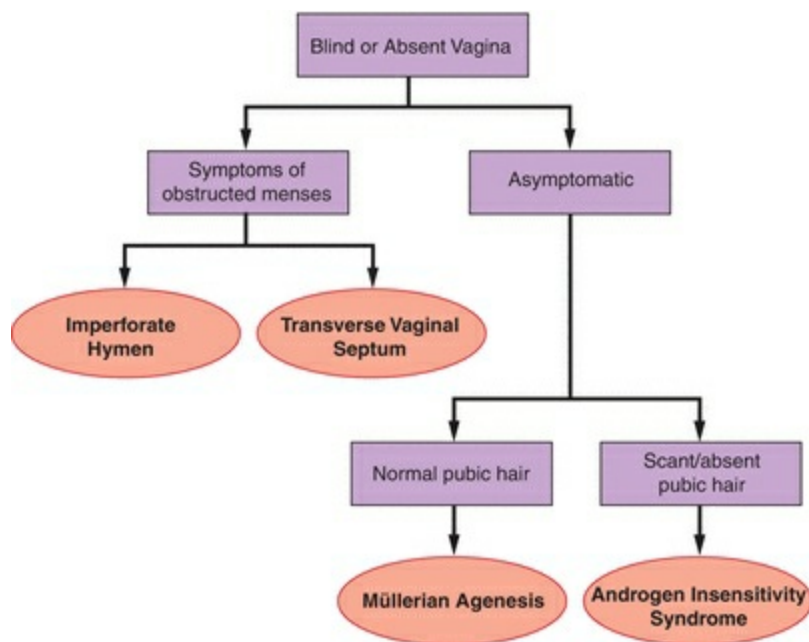
In premenarchal-age girls with the incidental finding of an absent vaginal orifice, diagnosis can be more difficult but also is seldom urgent. Although pelvic ultrasonography generally can determine whether a uterus is present, imaging must be interpreted cautiously because even abdominal/pelvic magnetic resonance imaging (MRI) can be misleading when the reproductive organs are immature and very small. Remaining alert to the diagnostic possibilities, careful observation over time is preferable to invasive investigations otherwise unnecessary in the asymptomatic prepubertal girl.

## Abnormal Genital Anatomy

The embryology of the female genital tract is complex but generally well defined and is described in detail in [Chapter 3](#). Briefly summarized, it involves both the medial migration and midline fusion of the müllerian (paramesonephric) ducts to form the uterus and fallopian tubes, cervix, and upper vagina and the vertical fusion of the developing müllerian ductal system with the invaginating urogenital sinus that forms the lower vagina and the introitus. Outflow tract abnormalities that result from failure of müllerian duct development include a spectrum of anatomical abnormalities that range from vaginal/müllerian agenesis to cervical agenesis, transverse vaginal septa, and imperforate hymen ([Figure 10.2](#)). Although all are uncommon and the clinician may have only limited or no previous experience with any of these anatomical malformations, each has unique and distinguishing features that, in most cases, point to the correct diagnosis at the time of the initial visit. Only limited additional evaluation, described in a later section of this chapter, is required to firmly establish the diagnosis and to plan treatment. AIS must be considered as a differential diagnosis in any girl presenting as primary amenorrhea and diagnosed with vaginal agenesis; the presence or absence of pubic hair distinguishes AIS from an isolated müllerian anomaly in a



genetically normal female.



**FIGURE 10.2**

## Normal Genital Anatomy

In those with primary or secondary amenorrhea having a patent vagina and visible exocervix, the likelihood of a genital outflow tract abnormality is very small. The only possibilities that need be considered are cervical stenosis and endometrial damage that may result from surgical trauma (Asherman syndrome) or infection (such as genital tuberculosis). Since these are acquired conditions, they result in secondary amenorrhea with an onset that typically correlates closely with the time of the previous insult. Both receive separate and thorough discussion in the later section of this chapter devoted to specific disorders of the genital outflow tract and uterus.

# Evaluation of Ovarian Function

In women with secondary amenorrhea, obstructive developmental disorders of the genital tract can be excluded. Similarly, in those with normal genital tract anatomy and no relevant history to suggest the possibility of acquired cervical stenosis or Asherman syndrome, disorders of the genital outflow tract and uterus can similarly be excluded. Further stepwise evaluation is then required to determine the underlying cause of amenorrhea, and attention now may be focused on the next level of the reproductive system, the ovary.

Abnormalities of ovarian function are the most common overall cause of amenorrhea (primary and secondary) and include a wide variety of disorders ranging from simple chronic anovulation as in women with PCOS to ovulatory dysfunction associated with obesity, thyroid disorders, and hyperprolactinemia, to ovarian failure or POI. Several conditions are associated with POI including genetic abnormalities (these can be chromosomal abnormalities or single gene disorders such as fragile X [FMR1] premutations or genetically inherited metabolic disorders such as galactosemia) or autoimmune disease, or following exposure to radiation or chemotherapy. These and other specific causes of ovarian failure and the mechanisms involved are discussed at length in a later section of this chapter. The focus here is on the evaluation of ovarian function and on the diagnosis and treatment of common chronic anovulatory disorders.

The most obvious measure of ovarian function is estrogen production. Unfortunately, one cannot rely just on symptoms and signs of estrogen deficiency to identify hypogonadal women. **Genitourinary atrophy develops only gradually and is not observed commonly in young women, even when estrogen levels are clearly low, and vasomotor symptoms typically are absent in women with hypothalamic dysfunction.** Other methods for assessing the level of ovarian estrogen production include measurement of the serum estradiol concentration and “bioassays” based on clinical observations of the amount and character of cervical mucus, the results of a “progesterin challenge test,” or measurement of endometrial thickness by transvaginal ultrasonography. **Although each method is informative to varying degrees, each also has pitfalls, no one method is definitive, and more than one measure therefore is recommended.** Overall, the duration of amenorrhea, other symptoms, medical history, and clinical examination all contribute to the overall assessment relating to ovarian function.

## Serum Estradiol Concentration

A serum estradiol measurement is easy to obtain, is relatively inexpensive, and provides some degree of objective assessment of ovarian steroidogenic function.

Reasonably, one would expect to find relatively normal estrogen levels (in premenopausal early follicular phase range) in women with normal ovaries whose amenorrhea results simply from mild dysregulation and chronic anovulation, as in obese women and those with PCOS, and to find low estrogen levels (in the menopausal range) in women with ovarian failure, pituitary disease, or more severe hypothalamic dysfunction. Unfortunately, serum estradiol concentrations can fluctuate erratically in all conditions, normal or low on any given day, and therefore can be misleading. A random estradiol concentration greater than approximately 40 pg/mL suggests the presence of functional ovarian follicles; such levels of estradiol however can also be encountered in women with POI, those in perimenopause, and sporadically in women with hypothalamic amenorrhea. Conversely, a low random estradiol concentration may suggest ovarian failure, but also is commonly encountered in women with hypothalamic amenorrhea, and may be observed in those with less severe forms of chronic anovulation.

## Bioassays of Estrogen Production

The observation of **estrogenic cervical mucus**—clear, watery, stretchable, and relatively abundant—suggests a normal level of ovarian estrogen production, but its absence cannot be interpreted confidently because many normal women exhibit such mucus only during the late follicular phase of the cycle when estrogen levels are relatively high, or not at all.

The **progestin challenge test** is based on the premise that progestin treatment (e.g., 5–7 days of exposure to MPA 10 mg daily or norethindrone acetate 1 mg daily) will induce a withdrawal bleed only in those whose endometrium has been exposed to circulating estrogen concentrations in premenopausal range. **A pure progestational agent must be used because endogenous estrogen status cannot be inferred from the response to an OCP that contains both estrogen and progestin.** The more potent synthetic progestins such as MPA are a better choice than oral micronized progesterone, which must be administered in relatively high doses (e.g., 200–300 mg daily) to achieve a response.<sup>1</sup> A positive test—bleeding within 2–7 days after completion of progestin treatment—implies endogenous estrogen production and is reassuring for residual ovarian function. A negative progestin challenge test—no withdrawal menses—suggests hypogonadism. Scant withdrawal bleeding or spotting suggests marginal levels of endogenous estrogen production. Despite the reassurance provided by a positive progestin challenge test, the overall correlation between withdrawal bleeding and estrogen status is far from perfect; both false-positive (withdrawal bleeding despite generally low levels of estrogen production) and false-negative (absent bleeding despite significant estrogen production) results are relatively common. Up to 40–50% of women whose amenorrhea relates to stress, exercise, weight loss,

hyperprolactinemia, or ovarian failure, in whom estrogen levels generally are low, exhibit some degree of withdrawal bleeding.<sup>2,3</sup> In contrast, up to 20% of amenorrheic women with significant estrogen production (such as women with PCOS who exhibit elevated circulating androgen levels) experience no withdrawal bleeding<sup>4</sup>; rationale for false-negative response lies in an endometrium that is rendered unresponsive by chronic exposure to high circulating androgen levels.

The **endometrial thickness**, determined by transvaginal ultrasonography (the maximum two-layer thickness in the midsagittal plane), is a measure of endometrial proliferation, which reflects the level of estrogen production. Endometrial thickness correlates with both the serum estradiol concentration and with the response to a progestin challenge in women with amenorrhea. In one study involving 44 women with secondary amenorrhea, endometrial thickness was significantly greater in 32 women who had withdrawal bleeding ( $10.3 \pm 4.1$  mm) than in 12 who did not ( $5.0 \pm 1.3$  mm); the serum estradiol level also was significantly greater ( $45.3 \pm 19.4$  vs.  $18.6 \pm 8.0$  pg/mL), and an endometrial thickness measuring 6.0 mm or greater predicted withdrawal bleeding with 95% accuracy.<sup>2</sup> An added potential benefit of endometrial thickness as a measure of ovarian estrogen production is that it can help to identify individuals with chronic anovulation at low risk for having associated pathology such as hyperplasia or cancer. In addition to thickness, the sonographic appearance of the endometrial echo is also informative of tissue estrogenization. A trilaminar-appearing endometrial echo correlates with proliferative effects of estrogen on the endometrium.

## **Serum Follicle Stimulating Hormone (FSH) Concentration**

The serum FSH concentration is a useful, but indirect, measure of ovarian function. A normal or low serum FSH level indicates the presence of functional ovarian follicles and may be observed in a variety of conditions associated with amenorrhea, including chronic anovulation (e.g., PCOS), pituitary disease, and hypothalamic dysfunction. Low FSH levels are also commonly seen in women using hormonal contraceptive regimens. **A high serum FSH concentration in the presence of amenorrhea is a reliable indicator of ovarian follicular depletion or ovarian failure.** Exceptions to this interpretation are rarely encountered and include inactivating mutations involving the FSH or LH receptor, enzyme deficiencies (17 $\alpha$ -hydroxylase, aromatase), and functional pituitary and ectopic FSH-secreting tumors; in these conditions, disproportionately elevated FSH levels will be seen despite the presence of ovarian follicles. **Because the clinical implications of an elevated FSH level are serious, one or more repeated measurements are warranted to confirm the finding (Table 10.1).**

**TABLE 10.1 Placing Serum Gonadotropin Levels in Clinical Perspective**

Clinical State	Serum FSH	Serum LH
Normal adult female	5–20 IU/L (midcycle peak ~ 2 times the basal level in ovulatory women)	5–20 IU/L (midcycle peak ~ 3 times the basal level in ovulatory women)
Hypogonadotropic state: Prepubertal, hypothalamic, or pituitary dysfunction	<5 IU/L	<5 IU/L
Hypergonadotropic state: Postmenopausal, castrate, or ovarian failure	>20 IU/L	>40 IU/L

Although certainly not inappropriate, generally it is neither necessary nor helpful to also measure serum LH because levels of the two gonadotropins typically move in parallel. The one notable and highly relevant exception in women with amenorrhea—the “monotropic” rise in FSH that signals a more advanced stage of follicular depletion—can be detected by measuring FSH alone. In women who are menstruating regularly, serum levels of FSH tend to be higher than of LH at all times in the cycle except for the periovulatory period. During the midcycle gonadotropin surge in ovulatory cycles, LH levels increase more than those of FSH, but that has little relevance in women with amenorrhea. A “reversed” LH/FSH ratio (FSH lower than LH), like that seen in prepubertal girls, suggests, but does not prove, hypothalamic dysfunction.<sup>5</sup> A moderately increased serum LH concentration frequently is observed in women with PCOS, but is

not a diagnostic criterion. Other conditions in which levels of the two gonadotropins diverge significantly are truly rare and include ectopic gonadotropin secretion by tumors outside the reproductive tract, single gonadotropin deficiencies resulting from mutations in genes encoding the  $\beta$ -subunit of LH or FSH, and the very rare functional gonadotroph adenoma that secretes clinically important amounts of one gonadotropin (FSH) but not the other.

Measurement of the serum FSH level traditionally has been recommended only for those having demonstrable evidence of hypogonadism (e.g., a negative progestin challenge), to help differentiate between patients with gonadal failure (in whom FSH levels will be elevated) and those with functional hypothalamic or pituitary causes of amenorrhea (in whom FSH levels will be in low or normal range). Measurement of serum FSH contributes to a more confident clinical assessment of ovarian function and helps differentiate patients with common chronic anovulatory conditions from those with more severe hypogonadism who otherwise may go unrecognized and who require further specific evaluation, counseling, or treatment. For example, when evaluation suggests marginal levels of estrogen production (e.g., serum estradiol levels of 30–40 pg/mL or lower or when scant bleeding follows a progestin challenge), a low serum FSH can identify those who merit further evaluation to exclude pituitary and hypothalamic disorder or disease, as described below. Conversely, in women with normal levels of estrogen production, a moderately elevated FSH level (e.g., 10–15 IU/L) is concerning for diminished ovarian reserve, and this information can be helpful in guiding women toward proactively exploring opportunities for fertility planning and preservation before the opportunity gets lost. Like the other measures of ovarian function, the serum FSH concentration must be interpreted carefully, in its clinical context. FSH levels can fluctuate unpredictably, particularly during the years immediately preceding the menopause, regardless whether it occurs prematurely or at the usual age. It is important to appreciate that a sharp rise in FSH occurs during the estrogen-induced LH surge; unless serum estrogen levels are also tested along with FSH, elevated FSH if drawn at the time of an LH surge can be erroneously interpreted to represent diminished ovarian reserve, a label that generates significant psychological distress.

## **Serum Antimullerian Hormone (AMH) Concentration**

A member of the TGF $\beta$  family of growth factors, AMH is secreted by the ovarian granulosa cells of the preantral and small growing follicles measuring less than 4 mm in diameter. Circulating levels of AMH are now recognized as a more reliable marker of ovarian reserve status compared to FSH. In contrast to FSH, where high levels are concerning for diminished ovarian reserve, higher AMH levels are reassuring. Undetectable AMH level in the setting of amenorrhea is highly concerning for ovarian

failure as a mechanism for amenorrhea. In contrast, levels greater than 5 ng/mL in association with amenorrhea are suggestive of PCOS as a plausible reason for amenorrhea. Measurement of AMH is reliable on any day in an individual's menstrual cycle, although prolonged periods of ovarian suppression, such as with use of hormonal contraceptives, can result in spuriously lower circulating AMH levels.<sup>6</sup>

## Chronic Anovulation

**When evaluation reveals clear evidence of adequate ovarian estrogen production and serum FSH and AMH levels are also normal, a diagnosis of chronic anovulation is established.** Hyperprolactinemia is one of the most common causes of anovulation and amenorrhea, and, although less common, thyroid disorders are easily identified and treated. **Measurement of serum prolactin and thyroid-stimulating hormone (TSH) concentrations is therefore justified in all women with amenorrhea.** For efficiency, both can be measured along with the serum FSH and estradiol levels, at the outset of the evaluation. When all are normal, no further evaluation is required.

Besides thyroid and prolactin disorders, common and likely causes of chronic anovulation include PCOS, obesity, psychological stress or intense exercise, and reproductive aging. In all but the last, anovulation can be attributed to a dysfunctional HPO axis in which gonadotropin secretion is sufficient to stimulate follicular development and estrogen production to varying degrees, but the system lacks the coordination required to achieve successful ovulation. Women with classical PCOS usually are easily recognized because they commonly exhibit signs of hyperandrogenism (such as acne and/or excessive facial and bodily hair or thinning of scalp hair), unlike those whose chronic anovulation relates solely to weight gain or obesity; the pathophysiology of the two disorders is complex and is discussed at length in [Chapter 11](#) (PCOS) and [Chapter 19](#) (obesity). Severe hirsutism ([Chapter 12](#)) or signs of virilization warrant additional specific evaluation to exclude steroidogenic enzyme deficiencies, androgen-secreting tumors, and Cushing syndrome, as described in [Chapter 13](#) (reproduction and the adrenal). The diagnosis of anovulation relating to emotional, nutritional, or physical stresses is often suggested by the medical history and the chronology of events, but is arrived at only after systematic exclusion of the conditions discussed above. Management of chronic anovulation associated with the commonly encountered thyroid disorders and hyperprolactinemia is summarized here.

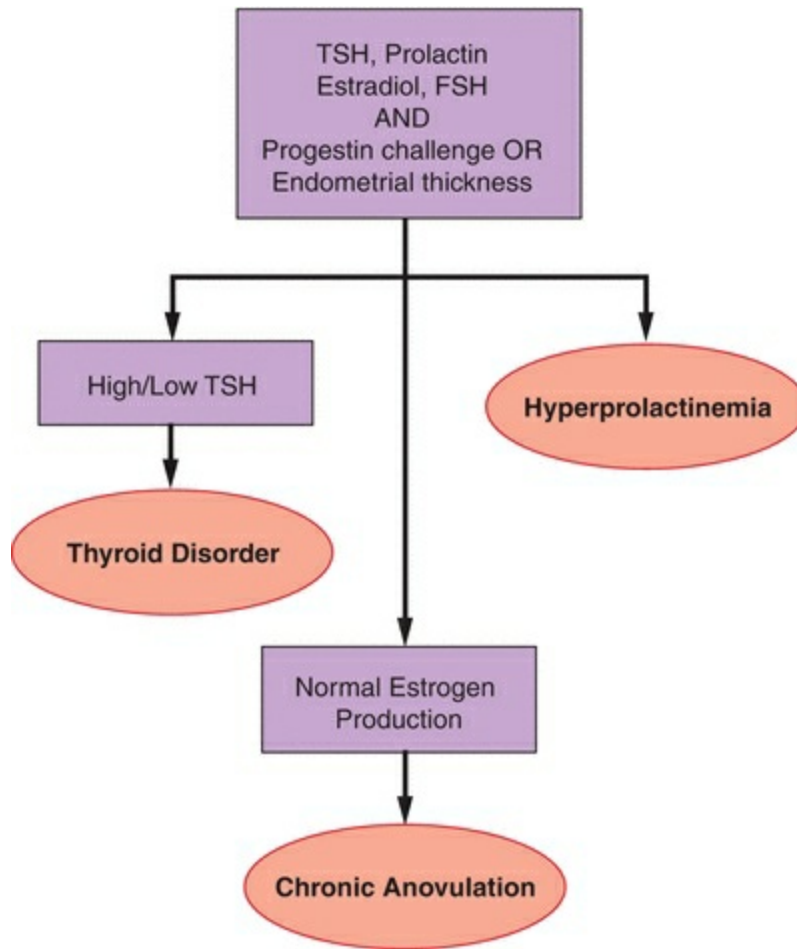
## Thyroid Disorders

The newest ultra-sensitive TSH assays now in common use detect both primary hypothyroidism (elevated TSH) and primary hyperthyroidism (low TSH); either may result in chronic anovulation and amenorrhea. Although only a few patients presenting



with amenorrhea will have a thyroid disorder that is not clinically apparent, their exclusion and treatment are so simple that routine measurement of TSH in the evaluation of menstrual disturbances is justified; a return of ovulatory cycles typically follows the restoration of normal thyroid hormone levels. Any abnormal TSH value should be confirmed by repeat testing that includes measurement of serum thyroxine (tetraiodothyronine; T4 or free T4) levels to better define the nature (primary vs. secondary) and the extent of the thyroid disorder. Elevated TSH with normal free T4 concentration indicates subclinical hypothyroidism, best viewed as a compensated state wherein normal levels of T4 are maintained, but only under increased levels of pituitary TSH stimulation. **Although observation and periodic reevaluation are reasonable in patients with subclinical hypothyroidism, because not all will develop frank hypothyroidism, treatment is warranted in those with menstrual dysfunction or infertility.** In those with a low TSH and a normal free T4 level, serum triiodothyronine (T3) should be measured; an elevated T3 can identify hyperthyroidism that otherwise might escape detection. When the T3 also is normal, subclinical hyperthyroidism is likely and should be followed carefully through vigilant clinical surveillance and periodic monitoring of TSH levels. On rare occasions, both TSH and free T4 levels are low, suggesting secondary hypothyroidism of pituitary origin; this requires further assessment to determine the cause of pituitary dysfunction. Evaluation of serum levels of other pituitary hormones, such as gonadotropins, prolactin, and ACTH, should be considered if secondary hypothyroidism is suspected, as this information will help guide further management.

A few women with hypothyroidism will develop secondary hyperprolactinemia and may even experience galactorrhea. The likelihood of hyperprolactinemia increases with the duration of hypothyroidism; galactorrhea is more common in young women with higher prolactin levels.<sup>7</sup> The mechanism probably involves both the gradual depletion of hypothalamic dopamine (the putative prolactin-inhibiting factor) and constant stimulation of pituitary lactotropes by the hypothalamic thyrotropin-releasing hormone (TRH), which may cause pituitary hypertrophy or hyperplasia and sometimes even enlargement or erosion of the sella turcica.<sup>8,9</sup> Although prolactin levels rapidly normalize with appropriate treatment of the accompanying hypothyroidism, the disappearance of breast secretions in those with galactorrhea is gradual and can take several months. Patients with primary hypothyroidism and hyperprolactinemia may present with either primary or secondary amenorrhea<sup>10</sup> (**Figure 10.3**).



**FIGURE 10.3**

## Hyperprolactinemia

Hyperprolactinemia is among the most common causes of secondary amenorrhea. Hyperprolactinemia occurring in premenarchal years may even present as delayed puberty and primary amenorrhea. **Checking serum prolactin level is therefore justified in all women with amenorrhea.** A normal random measurement (<15–20 ng/mL in most clinical laboratories) excludes hyperprolactinemia. Circulating prolactin levels are fairly stable throughout the day but can increase transiently during sleep, and with exercise, breast stimulation, and meals. **To avoid otherwise unnecessary and costly imaging, mildly elevated prolactin levels (20–40 ng/mL) are best repeated and confirmed before the diagnosis of hyperprolactinemia is made.**

The mechanism by which hyperprolactinemia results in anovulation and amenorrhea relates to a disruption or inhibition of the normal hypothalamic GnRH pulse rhythm, resulting in ineffective or even frankly low levels of gonadotropin secretion. It may be that increased circulating prolactin levels stimulate a generalized increase in hypothalamic dopaminergic neuronal activity, intended to suppress prolactin secretion,

but also inhibiting the GnRH neurons. Consequences of the disturbed GnRH pulsatility due to prolactin excess can range from subtle ovulatory dysfunction to anovulation or even profound hypogonadotropic hypogonadism, depending on the extent to which the gonadotropin secretion is suppressed. Mild hyperprolactinemia (levels in the range of 20–50 ng/mL) may cause only a short luteal phase, resulting from poor preovulatory follicular development.<sup>11,12</sup> Moderate hyperprolactinemia (50–100 ng/mL) frequently causes oligomenorrhea or amenorrhea, and higher prolactin levels (>100 ng/mL) typically result in frank hypogonadism with low estrogen levels and their clinical consequences (e.g., genitourinary atrophy, and loss of bone mass).<sup>13,14</sup>

Despite galactorrhea being a recognized consequence of prolactin excess, the symptom or finding of galactorrhea cannot reliably identify those whose amenorrhea results from hyperprolactinemia. Only about one-third of women with hyperprolactinemia exhibit galactorrhea, probably because breast milk production requires estrogen and hyperprolactinemia often results in anovulation or a more severe secondary hypogonadotropic hypogonadism and, consequently, low circulating estrogen levels. The structural heterogeneity of prolactin offers another possible explanation. Prolactin circulates in various forms that have varying bioactivity (manifested by galactorrhea) and immunoactivity (recognition by immunoassay).<sup>15,16,17</sup> The predominant circulating form of prolactin (80–95%) is monomeric (molecular weight 23 kDa), which is more biologically active than the larger glycosylated variants that may combine to form dimers or trimers (“big prolactin,” 50–60 kDa) and other even larger varieties (macroprolactin, >100 kDa), which result from the aggregation of smaller prolactin molecules bound together with immunoglobulins.<sup>18</sup> The larger molecular forms are cleared more slowly, predominate in women with hyperprolactinemia having normal menses, and result in minimal or no galactorrhea.<sup>19</sup> If suspected, the diagnosis of macroprolactinemia can be confirmed by requesting the laboratory to pretreat the patient’s serum with polyethylene glycol to precipitate the macroprolactin before performing the prolactin assay.<sup>20</sup> In women with mildly elevated prolactin levels, diagnosis of macroprolactinemia avoids unnecessary and costly imaging aimed at excluding pituitary and hypothalamic mass lesions.

Hyperprolactinemia has many causes that are discussed in detail in the chapter dedicated to the breast ([Chapter 16](#)) and briefly summarized here.<sup>21</sup> Hyperprolactinemia may result from hypothyroidism, prolactin-secreting pituitary adenomas, and other pituitary or hypothalamic tumors that may compress the pituitary stalk and disrupt the delivery of dopamine. A variety of drugs that lower dopamine levels or inhibit dopamine action may cause hyperprolactinemia, including amphetamines, benzodiazepines, butyrophenones, metoclopramide, methyl dopa, opiates, phenothiazines, reserpine, and tricyclic antidepressants. Breast or chest wall surgery,

cervical spine lesions, or herpes zoster (affecting the dermatome that includes the breast) may activate the afferent sensory neural pathway that stimulates prolactin secretion in a manner similar to suckling. Renal insufficiency may cause hyperprolactinemia, due to decreased clearance. Rarely, hyperprolactinemia may result from ectopic prolactin secretion by bronchogenic and renal cell carcinomas, or by a gonadoblastoma or prolactinoma that may arise in benign or malignant ovarian teratomas, or from aberrantly located pituitary tissue in places such as the pharynx.<sup>22,23,24,25,26</sup> All possible causes must therefore be considered and excluded; a careful history can eliminate most of the possibilities. When iatrogenic mechanism for prolactin excess is deemed as a plausible cause, a trial of drug discontinuation or use of an alternative medication can be considered, in consultation with the prescribing physician. When discontinuation or drug substitution is not possible, further evaluation to exclude a pituitary or hypothalamic mass lesion is required before concluding that prolactin excess is entirely of iatrogenic origin.

**Women with amenorrhea and hyperprolactinemia that cannot be attributed confidently to medication or another specific cause require further evaluation with imaging to exclude pituitary tumors and hypothalamic mass lesions.** (See “Evaluation of Pituitary Function” section.) Pituitary adenomas and their management are discussed in detail in a later section of this chapter devoted specifically to pituitary causes of amenorrhea. Discussion here is limited to the treatment of hyperprolactinemia unassociated with any demonstrable sellar abnormality.

Treatment with a dopamine agonist restores ovulatory function and menses within several weeks in the large majority of women with hyperprolactinemia. Although improvement in galactorrhea is anticipated with decline in circulating prolactin levels, the absolute resolution of milk leakage following normalization of prolactin levels often lags by weeks to even months.<sup>27</sup> Bromocriptine and cabergoline are two commonly utilized dopamine agonists in the management of hyperprolactinemia; both are highly effective. Bromocriptine has a relatively short half-life, often necessitating a frequency of administration of 2 to 3 times daily; gastrointestinal side effects such as nausea are common, and bedtime dosing is better tolerated. Cabergoline is a selective dopamine receptor type 2 agonist having fewer side effects than bromocriptine, greater potency, and a longer duration of action requiring less frequent administration (twice weekly) and can be effective in those who cannot tolerate or prove resistant to bromocriptine<sup>28,29</sup>; due to its better tolerance and convenience of dosing, cabergoline is increasingly being utilized as the preferred of the two dopamine agonists. Long-term use of dopamine agonists in relatively high doses, such as used in the management of Parkinson disease (>3 mg daily), has been associated with hypertrophic valvular heart disease; mitogenic stimulation of normally quiescent valve cells via activation of the serotonin receptors is a suspected mechanism for this uncommon but serious risk of

long-term use of dopamine agonists in high doses.<sup>30,31</sup> Although the doses required for effective treatment of hyperprolactinemia are much lower than used for treatment of Parkinson disease, concerns remain that long-term use of even relatively low doses of dopaminergic drugs may increase the risk of valvular heart disease.<sup>32,33</sup> Treatment should begin with a low-dose regimen, and dosing should be gradually adjusted in increments to achieve normalization of prolactin levels; the goal should be to utilize the lowest dose of cabergoline or bromocriptine required to normalize serum prolactin concentrations. Given the concerns relating to long-term use of dopaminergic drugs, a trial discontinuation of treatment should be attempted if prolactin levels have been normal for 2 or more years.<sup>34</sup> In those who cannot tolerate oral treatment, vaginal administration is effective and associated with fewer side effects.<sup>35,36</sup> Either drug may be used in women planning to conceive since both appear to be safe in early pregnancy.<sup>37,38</sup>

Treatment with a dopamine agonist is the obvious choice when the objective is ovulation induction and pregnancy or the elimination of troublesome galactorrhea. However, for those with neither specific indication, alternative treatments deserve careful consideration. **Although treatment with a dopamine agonist certainly is a logical choice, it is by no means the only choice or necessarily the best choice for all women with hyperprolactinemia and amenorrhea. It is important to remember that treatment should be focused on the patient and not on the prolactin level.** Hyperprolactinemia itself poses no particular health risks. In women not at risk for an unwanted pregnancy, cyclic progestin therapy will prevent the clinical consequences of chronic unopposed estrogen exposure in those who are not frankly hypogonadal. For those manifesting signs and/or symptoms of hypoestrogenism, cyclic or combined estrogen/progestin treatment in physiologic doses, such as used for managing menopausal symptoms ([Chapter 17](#)), will prevent the consequences of chronic estrogen deficiency. In women who need contraception, treatment with a low-dose combination hormonal contraceptive achieves the same goals. In the past, treatment with exogenous estrogen was considered contraindicated for women with hyperprolactinemia due to a fear that this might aggravate the underlying pathophysiology or promote the growth of an underlying pituitary tumor; however, experience has shown that estrogenic formulations (used as menopausal hormone therapy or as combination hormonal contraceptives) pose no such risks.<sup>39,40</sup> The same treatments are useful in the management of women with medication-induced hyperprolactinemia and hypogonadism when the drug cannot be discontinued or an alternative substituted. Dopamine agonists are best avoided in patients with medication-induced hyperprolactinemia, because they may interfere with or counteract the dopamine antagonist properties of their primary treatment. Unfortunately, amenorrhea and galactorrhea often promptly recur within weeks after discontinuation of dopamine agonist treatment and most therefore require

long-term therapy.

## General Management

All patients with chronic anovulation require management, and following a limited evaluation, as described here, treatment can be implemented immediately. Clinicians are keenly aware that normal endometrium that is chronically exposed to an estrogenic environment without antagonistic influences of periodic progesterone exposure as occurs in ovulatory cycles can progress to hyperplasia, atypia, and cancer within a relatively short interval of time. However, too often they believe the problem is relevant only in older age women. **The critical factor in determining the risk for these endometrial pathologies is not the age but the duration of exposure to unopposed estrogen stimulation.** Young women who remain anovulatory for long periods of time can, and do, develop endometrial cancer.<sup>41,42,43,44</sup> Although endometrial sampling is not indicated for all women with chronic anovulation, it should be given serious consideration for those at greatest risk for endometrial pathology. Obesity, hyperinsulinemia, and diabetes are recognized risk factors for endometrial cancer, and these risks are especially prevalent in women with PCOS, a population that is especially deemed at risk for endometrial hyperplasias and cancer.<sup>45,46</sup> Although endometrial thickness, as assessed by transvaginal ultrasound, can offer valuable prognostic yield in identifying postmenopausal women at risk for endometrial hyperplasia and cancer, it is of little value in prognosticating a similar risk profile in premenopausal amenorrheic populations. No studies correlating endometrial thickness and histology in premenopausal women with amenorrhea have been performed. However, in premenopausal women with abnormal uterine bleeding, no serious pathology was found in those having an endometrial thickness less than 8 mm,<sup>47</sup> and in asymptomatic postmenopausal women, an endometrial thickness less than 5–6 mm has greater than 99% negative predictive value for endometrial disease.<sup>48,49</sup> A thin endometrium (<4 mm) may be useful in identifying those amenorrheic women in whom an invasive intervention such as an endometrial biopsy may be safely omitted; their risk for endometrial pathology is likely negligible. Whereas some studies have suggested that amenorrheic women also may be at an increased risk for developing breast cancer,<sup>50</sup> others have demonstrated an inverse association between breast cancer risk and chronic anovulation (discussed in [Chapter 16](#)).<sup>51</sup>

Given the recognized risk of endometrial hyperplasia and cancer from chronic endometrial exposure to estrogen, at a minimum, women with chronic anovulation require periodic treatment with a progestin, to negate the proliferative endometrial effects of estrogen and thereby reduce the risk of developing endometrial pathology. For example, a synthetic progestin such as MPA in doses of 5–10 mg daily can be

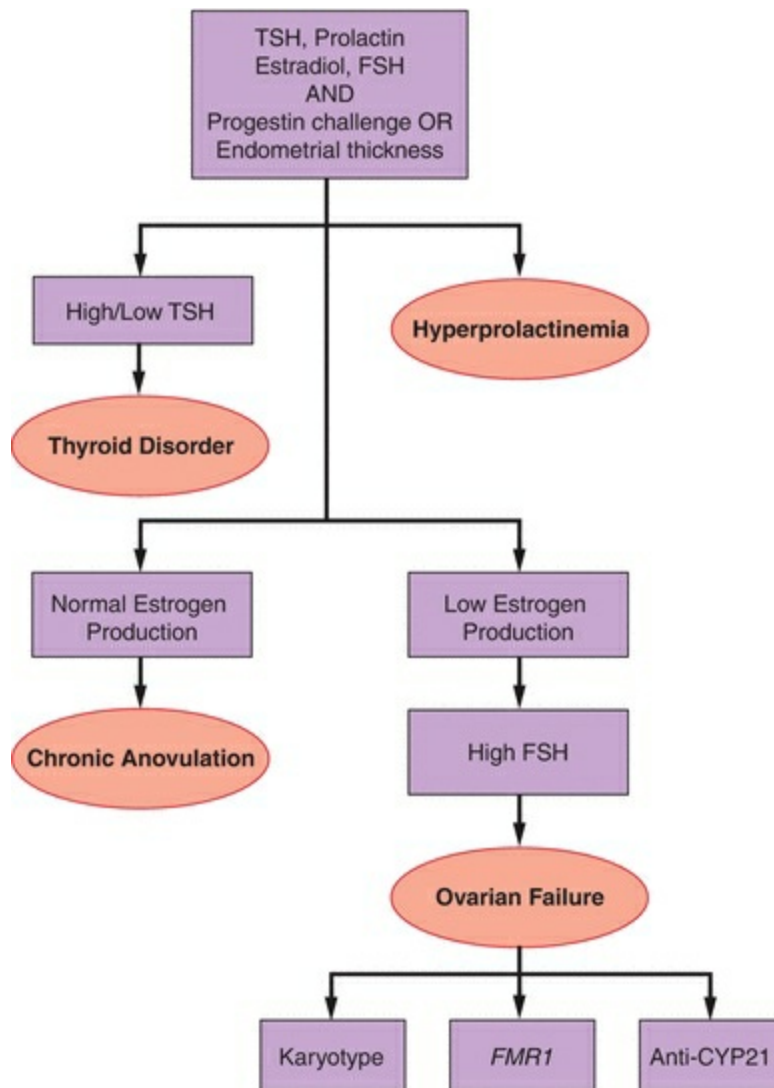
administered for the first 12–14 days of each month; for some women, the frequency of progestin exposure can be stretched to every alternate month. Experience with varying hormone regimens has demonstrated that duration of treatment, as well as type and dose of progestin formulation, are relevant to ensuring endometrial protection. At minimum, treatment with a potent progestin, such as MPA, for an interval greater than 10 days is required to effectively counteract the growth-promoting effects of continuous exposure to endogenous estrogens. A higher dose and longer treatment duration may be considered in obese women who are innately at a higher risk for endometrial cancer. **It is important to note that cyclic treatment with a progestin, at physiologic doses, does not change the intrinsic rhythm of the HPO axis and will not prevent a sporadic ovulation.** Therefore, if menses do not occur at the expected time, pregnancy must be considered and excluded. Absent bleeding after a course of progestin treatment also may indicate that estrogen production has fallen to grossly low levels and signal the need for further evaluation, as described in the section that follows. When reliable contraception is required, cyclic treatment with a low-dose hormonal contraceptive, or consideration for a progestin-only regimen (pill, implant, or intrauterine system), is an obvious and better choice. There is no evidence that use of hormonal contraception has any impact, either positive or negative, on menstrual cyclicity after treatment is discontinued.

For women with chronic anovulation who are desirous of achieving pregnancy, treatment should be aimed at inducing ovulatory cycles. For women with thyroid disorders, specific treatment to restore normal thyroid function is indicated. For those with hyperprolactinemia, initiating a dopamine agonist is the treatment of choice. Those experiencing anovulation in the setting of psychological stress or excess weight gain may achieve resumption of spontaneous ovulation from stress and weight reduction, respectively, whereas those experiencing amenorrhea in the setting of nutritional deprivation and low body mass, resumption of ovulation may be achieved through improved diet and weight gain. For the majority who are without an obvious mechanism for their ovulatory dysfunction, successful ovulation can be achieved with the use of ovulation induction agents such as clomiphene citrate or aromatase inhibitors. Exogenous gonadotropins can be considered for those failing to respond to oral medications. Methods for ovulation induction are described in detail in [Chapter 27](#).

## **Ovarian Failure and Ovarian Insufficiency**

**When evaluation reveals evidence of low ovarian estrogen production and serum FSH level is consistently high, a diagnosis of ovarian failure is established.** Amenorrheic women, if younger than age 40 years, with evidence of persisting hypergonadotropic hypogonadism are diagnosed with premature ovarian failure (POF), a condition that in recent years is preferentially referred to as POI; the terms POF and

POI are used interchangeably in this chapter. Although premature follicular depletion is the cause in almost all cases, additional specific evaluation is indicated to exclude conditions (such as chromosomal and other genetic abnormalities and autoimmune disease) that may have potential health implications for the patient and other members of her family. The elements and purpose of the expanded diagnostic evaluation of POI cases are summarized here (Figure 10.4). The known causes of ovarian failure and the disorders deserving specific consideration and exclusion are discussed at greater length in a later section of this chapter.



**FIGURE 10.4**

## Karyotype

In all patients under age 30 with a diagnosis of POI, a karyotype should be obtained to exclude chromosomal translocations, deletions, and mosaicism that might offer an



obvious explanation for premature failure of the ovaries. A karyotype will identify those missing an entire X chromosome in all (Turner syndrome) or some (Turner mosaic) of the tested cells. Chromosomal analysis will similarly identify those phenotypic... phenotypic females having a Y chromosome in whom gonadectomy is indicated due to the significant risk for malignant transformation in occult testicular gonadal tissue elements (20–30%). Signs of virilization cannot reliably identify the subset of women at risk because many carrying a Y chromosome exhibit no signs of androgen excess. In women over age 30, ovarian failure reasonably can be regarded as premature menopause. Karyotype after age 30 generally is unnecessary because most tumors in patients with a Y chromosome arise before age 20 and virtually all before the age of 30.<sup>52,53</sup> After age 30, women with short stature or a family history of early menopause still merit a karyotype to exclude X chromosome deletions and translocations that may affect other family members.<sup>54,55,56,57</sup> Pelvic ultrasonography can exclude the rare tumor not recognized previously. Genetic underpinnings to POI are further discussed later in this chapter.

## **Fragile X (FMR1) Premutations**

Fragile X syndrome is the most common inherited cause of mental retardation and autism and results from the abnormal expansion of an unstable trinucleotide (CGG) repeat sequence in the FMR1 (Fragile X Mental Retardation) gene that is located on the long arm of the X chromosome (Xq27.3). The FMR1 gene normally contains about 30 or less CGG repeats, but in those with FXS, the number of these trinucleotide repeats exceeds 200. Convincing evidence has demonstrated an association between POI and fragile X “premutations,” in the range of 55–200 CGG repeats. Whereas the full mutation silences the FMR1 gene, resulting in little or no production of the corresponding mRNA or gene product (fragile X mental retardation protein, FMRP), POI associated with premutations may reflect FMR1 mRNA gain-of-function toxicity.<sup>58</sup> Women with premutations often exhibit endocrine evidence of early ovarian aging (such as low circulating levels of AMH and inhibin B and higher FSH levels) in comparison to age-comparable women with normal FMR1; up to one-third of the premutation carriers experience early menopause (at age < 45 years). The prevalence of premutations is approximately 14% in women with familial POF and between 1% and 7% in sporadic cases of POF.<sup>58,59</sup> **Women with POI therefore should be offered testing for FMR1 premutations.**<sup>60</sup> Women who carry fragile X premutations (and any affected children or siblings) are at risk for having a child with Fragile X syndrome, because the length of the CGG repeat sequence is unstable and may expand to a full mutation when passed from mother to offspring. The inheritance and the implications of premutations are complex, and affected women therefore should receive formal genetic counseling. The FMR1 premutation–related POI is further discussed later in this

chapter.

## Autoimmune Screening

A number of autoimmune disorders have been linked with POI.<sup>61</sup> Addison disease (autoimmune adrenocortical insufficiency) has the strongest association with POF. The presence of autoantibodies to steroid-producing cells and observations of a lymphocytic infiltrate in the ovaries of the affected individuals suggest the underlying mechanism (autoimmune oophoritis).<sup>62</sup> The prevalence of other autoimmune diseases (e.g., thyroid autoimmunity, type I diabetes, and myasthenia gravis) is higher among women with POF than in the general population; however, there is no direct or compelling evidence to indicate a cause and effect relationship. Autoimmune ovarian failure generally occurs as part of a specific autoimmune polyendocrine syndrome (APS) that includes adrenal insufficiency. However, because POF may precede the onset of adrenal insufficiency by several years, the autoimmune cause may not be recognized when the diagnosis of POF is first made.<sup>61</sup> Women with POF should be screened for antiadrenal antibodies (most easily demonstrated against the 21-hydroxylase enzyme, CYP21) and for antithyroid antibodies (antithyroid peroxidase and antithyroglobulin antibodies) to help quantify their lifetime risk for respective end-organ damage. **The presence of antiadrenal antibodies strongly implies autoimmune oophoritis as the cause of POF and identifies women who should be carefully evaluated and should undergo periodic surveillance for early detection of adrenal insufficiency. The presence of thyroid autoantibodies does not prove autoimmune ovarian failure but identifies women at risk for developing autoimmune thyroid disorders, and these women should similarly undergo periodic surveillance for early detection of thyroid dysfunction.** Routine screening for other autoimmune endocrine disorders is unnecessary and can be reserved for those with clinical indications.<sup>63</sup> Autoimmunity-related POF is further discussed later in this chapter.

# Evaluation of Pituitary Function

The normal feedback relationship between ovarian estrogen production and pituitary gonadotropin secretion dictates that low estrogen levels, as in the early follicular phase of the menstrual cycle, should cause a compensatory increase in FSH release in attempts to stimulate ovarian follicular development and estrogen secretion. In the setting of amenorrhea, low serum FSH (<5 IU/L) and low estrogen concentrations identify inadequate or ineffective gonadotropin secretion as the mechanism and indicate that even the basic central feedback mechanisms in the HPO axis are not functioning. **When estrogen levels are clearly low (<20 pg/mL), a serum FSH level in the low normal range (5–10 IU/L) has the same interpretation and clinical implication**, for two reasons. First, given the recognized feedback relationship, the FSH level should be high when the estrogen levels are low, and thus a “normal” FSH value is, in fact, abnormally low in that clinical context. Second, although the measured level of immunoreactive FSH may be normal, the level of biologically active FSH clearly is not; if it were, follicular growth and estrogen production would be maintained. The biologic activity of glycoprotein hormones varies with their carbohydrate moieties (discussed in [Chapter 1](#)). Evidence indicates that women with hypogonadotropic hypogonadism may secrete gonadotropins having altered patterns of glycosylation and reduced biologic activity.<sup>64</sup> Indeed, most women with hypogonadotropic hypogonadism have normal serum gonadotropin concentrations; extremely low or undetectable gonadotropin levels typically are observed only in those with large nonsecreting pituitary tumors or in patients with anorexia nervosa.

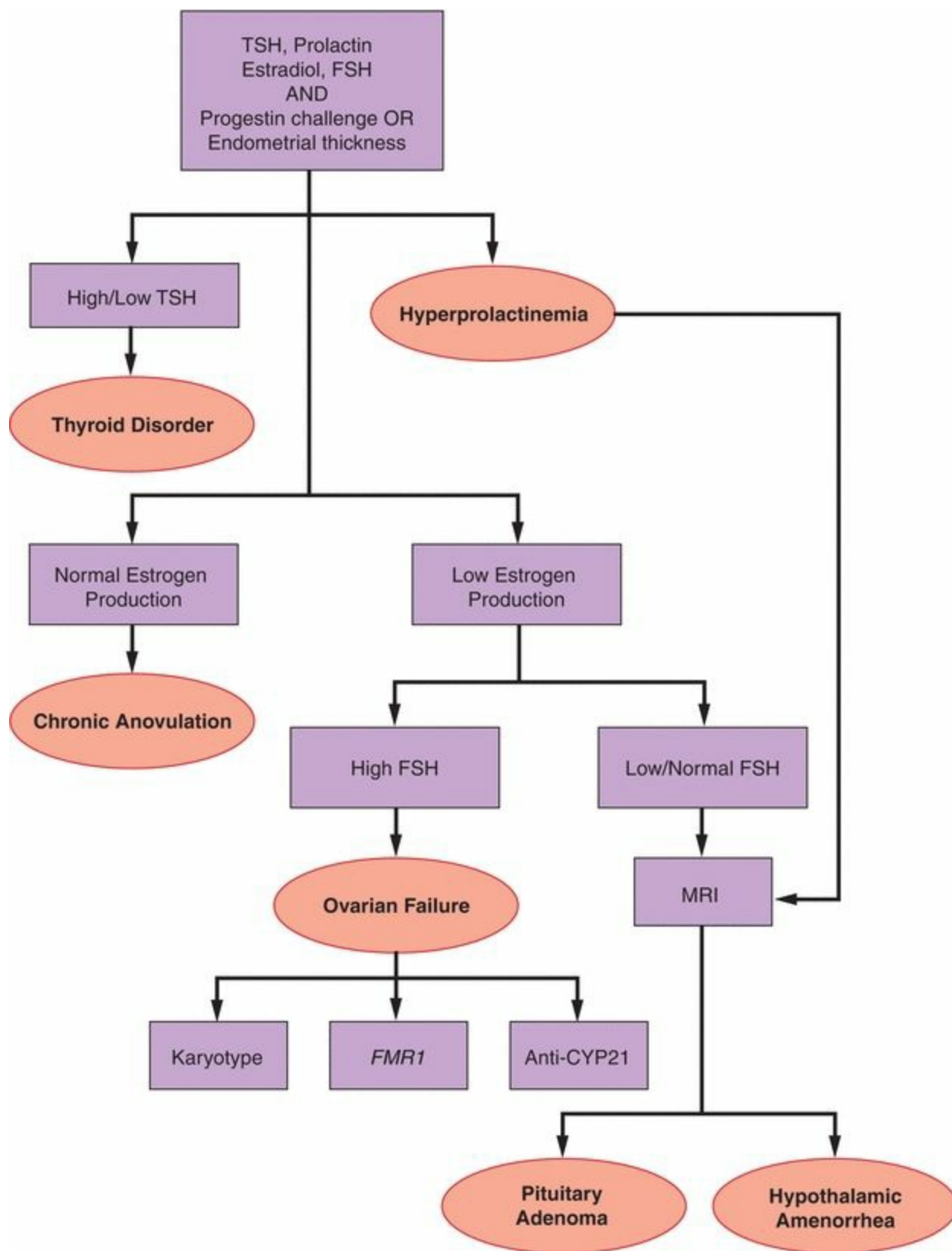
## Imaging

**When there is no clear explanation for hypogonadotropic hypogonadism (e.g., absence of significant physical, nutritional, or emotional stress) or for persistent hyperprolactinemia (e.g., use of medications), further evaluation with imaging is indicated to exclude intracranial tumors and to help distinguish between pituitary and hypothalamic causes.** The method of choice for imaging of the hypothalamic and pituitary regions is an MRI (with gadolinium contrast); brain MRI with contrast is more sensitive and accurate than other imaging techniques for the detection of abnormalities within and near the sella turcica.<sup>65</sup> Pituitary MRI can demonstrate the nearby optic chiasm, differentiate between hemorrhage and vascular abnormalities, and distinguish these from other sellar mass lesions. Pituitary adenomas are the most common sellar masses, which account for 10% of all intracranial neoplasms. Other less common mass lesions in or near the sella include benign tumors (craniopharyngioma, hamartoma, meningioma), pituitary hyperplasia (thyrotroph or gonadotroph hyperplasia due to long-standing primary hypothyroidism or gonadal failure, respectively, and corticotroph

hyperplasia that commonly follows bilateral adrenalectomy), malignant tumors (germ cell, sarcoma, chordoma, carcinoma, lymphoma), metastases (lung, breast), cysts (Rathke cleft, arachnoid, dermoid), pituitary abscess, lymphocytic hypophysitis, sarcoidosis, tuberculosis, and carotid arteriovenous fistula.

Although mass lesions are the most obvious abnormality to be excluded as a mechanism for HPO dysfunction in women with amenorrhea, other rare possibilities include Sheehan syndrome (pituitary infarct resulting from hypotension associated with postpartum hemorrhage; medical history is highly informative in these cases), infiltrative hemosiderosis relating to frequent transfusions or hereditary hemochromatosis, traumatic brain injury,<sup>66</sup> and mutations in the GnRH receptor.<sup>67</sup>

**In the absence of any radiologically demonstrable mass lesion in the sellar region or relevant history suggesting another specific cause for pituitary damage, there is no need to perform any additional specific pituitary function tests (Figure 10.5).** The clinical signs and symptoms associated with different types of functional and nonfunctional pituitary tumors and other specific pituitary causes of gonadotropin deficiency are discussed in a later section of this chapter.



**FIGURE 10.5**

## Evaluation of Hypothalamic Function

When brain imaging reveals no mass lesion and there is no reason to suspect other specific pituitary pathology, the diagnosis by exclusion is that of **functional hypothalamic amenorrhea** (FHA). The pathophysiology of FHA relates to a suppressed or otherwise abnormal pattern of pulsatile hypothalamic GnRH secretion, resulting in decreased gonadotropin secretion, absent follicular development with consequent anovulation, and low serum concentrations of estradiol. Serum levels of FSH (and LH, if measured) are low or in the normal range; often, but not always, the FSH level is higher than LH, a pattern that is reminiscent of the prepubertal period.

Unfortunately, there is no simple way to test, manipulate, or directly measure the hypothalamic function in clinical settings to prove the existence of GnRH deficiency in FHA. Whereas one might anticipate that the LH response to a bolus of exogenous GnRH (e.g., 100 mg, administered subcutaneously) would be revealing, experience has shown that it may be normal (>10 IU/L) or low in women with pituitary or hypothalamic disease. The response to repeated bolus GnRH administration (e.g., 24 hours after the first) may be somewhat more informative, due to the recognized self-priming effect that GnRH has on its own receptor.<sup>68</sup> Administration of exogenous GnRH in a pulsatile manner using a programmable infusion pump can effectively restore normal gonadotropin secretion and menstrual function and induce ovulation in women with hypothalamic amenorrhea,<sup>69,70</sup> but the considerable costs and logistical challenges of such treatment make it impractical and impossible to justify this approach as a diagnostic test.

In most cases, the probable cause of hypothalamic amenorrhea can be identified, such as extreme emotional stress, acute weight loss or chronic malnutrition, or strenuous physical exercise. However, in others with hypothalamic amenorrhea, no obvious cause or precipitating event may be identified. Rare individuals with idiopathic hypogonadotropic hypogonadism may present with primary amenorrhea and infantile sexual development due to a congenital GnRH deficiency, resulting from the failure of GnRH neuronal development during embryogenesis or from mutations in the GnRH receptor. Beyond the workup discussed, any specific evaluation to identify such rare abnormalities is not clinically necessary nor indicated, except perhaps when other family members are affected. The various causes of hypothalamic amenorrhea and its management are discussed at length in a later section of this chapter devoted to specific disorders of the hypothalamus.

# **SPECIFIC CAUSES OF AMENORRHEA**

---

With only modest effort, time, and expense, the problem of amenorrhea has been dissected by systematic evaluation of the organ systems that are critical to normal menstrual function—the genital outflow tract and uterus, the ovary, the anterior pituitary, and the hypothalamus. Once the anatomic level of dysfunction has been identified, further management can be tailored to a specific diagnosis. This section of the chapter considers each of the major causes of amenorrhea and their management, organized by organ system.

# Disorders of the Genital Outflow Tract and Uterus

Anatomical disorders of the genital outflow tract and the uterus are relatively uncommon causes of amenorrhea. Congenital developmental anomalies of the genital outflow tract and uterus that result from a failure of müllerian duct development (vaginal/müllerian agenesis, AIS) and failure of vertical fusion (imperforate hymen, transverse vaginal septum, or cervical atresia) present at or near the expected time of menarche as primary amenorrhea. Acquired disorders of the genital outflow tract or uterus that can present as secondary amenorrhea include intrauterine adhesions, resulting from surgical trauma or infection (Asherman syndrome), and cervical stenosis, often resulting from surgical procedures undertaken for management of cervical dysplasias and cancer, such as LEEP or cone biopsy. These acquired conditions present as secondary amenorrhea with an onset that typically correlates closely with the time of previous insult; clinical history is therefore a critical component of evaluation and helps guide the next steps of management.

## Imperforate Hymen

The hymen is formed by invagination of the posterior wall of the urogenital sinus and usually undergoes spontaneous dissolution during the perinatal period. Although most cases of imperforate hymen occur sporadically, reports of families with several affected members suggest that some cases may have a genetic and heritable cause.<sup>71</sup>

Imperforate hymen commonly occurs as an isolated anatomical defect, although in a minority, additional müllerian anomalies involving higher levels of the outflow tract may coexist. The HPO axis is intact, and the uterine endometrium is responsive to cyclic ovarian hormonal fluctuations with cyclic shedding of the menstrual endometrium. There is a progressive buildup of the menstrual blood in the vagina (hematocolpos) and the endometrial cavity (hematometra). Typically, the clinical presentation is that of primary amenorrhea in the setting of normal secondary sexual characteristics. Proximate to the time of anticipated menarche, patients with an imperforate hymen start experiencing worsening cyclic perineal, pelvic, or abdominal pressure or pain that results from the gradual accumulation of obstructed menstrual flow (cryptomenorrhea). Patients may present with acute urinary retention due to compression of the urethra and bladder by a grossly distended lower vagina.<sup>72</sup> With delay in diagnosis and intervention, imperforate hymen with resulting hematometra imposes a real risk for the development of severe endometriosis due to the ongoing retrograde spill of uterine blood into the peritoneal cavity through the patent fallopian tubes. **Examination of the external genitalia reveals no obvious vaginal orifice and a thin, often bulging, blue perineal membrane**



**at the inferior limit of a palpable, fluctuant mass (hematocolpos).** This blue bulging membrane at the introitus becomes prominent during a Valsalva maneuver. The treatment of girls with an imperforate hymen centers on providing relief of symptoms related to the accumulated menstrual fluid and debris. Definitive surgery should be accomplished as soon as possible because delay can lead to infertility due to inflammatory changes and to the development of severe endometriosis. Surgical correction of an imperforate hymen is straightforward. The classical procedure is to make a simple cruciate incision in the bulging hymen extending to the base of the hymenal ring and to excise its central portion to allow drainage of the sequestered menstrual fluid and subsequent normal menstrual egress. Alternatively, to avoid any risk of damage to the hymenal ring (a sign of virginity that is important to some individuals and in some cultures), a sterile puncture can be made in the center of the distended membrane and enlarged to approximately 0.5 cm in diameter to allow insertion of a 16-F Foley catheter. After thorough drainage of the vagina via irrigation with sterile saline, the catheter is left in place for approximately 2 weeks to allow further drainage from the vagina and the upper genital tract. A single dose of prophylactic antibiotics is prudent, and estrogen cream applied locally to the hymenal ring helps to encourage re-epithelialization.<sup>73</sup> If the latter approach is undertaken, use of tampons should be encouraged until sexual activity is initiated so as to minimize a plausible risk of scarring-related stricture of the surgically created vaginal opening.

## **Transverse Vaginal Septum/Cervical Atresia**

A transverse vaginal septum results when the vaginal plate, formed from the fused sinovaginal bulbs, fails to break down or canalize during embryogenesis. As could be expected, girls with a transverse vaginal septum or cervical atresia, like those with an imperforate hymen, generally present at or soon after the age of expected menarche with primary amenorrhea and complaints of cyclic pelvic or abdominal pain due to obstructed menses and exhibit symmetrical, age-appropriate secondary sexual development. **Physical examination reveals a normal vaginal orifice, a shortened vagina of varying length, no visible cervix, and a palpable hematocolpos in the proximal vaginal segment above the obstruction and/or a pelvic mass resulting from hematometra and hematosalpinges.** A Valsalva maneuver will cause distension at the introitus in those with an imperforate hymen, but not in those with a transverse vaginal septum or cervical atresia, and can help to distinguish the two. Imaging is necessary to define the anatomy of the disorder, but laboratory investigation generally is not required. Pelvic ultrasonography can reveal the level and extent of the hematocolpos and any associated hematometra or hematosalpinges. However, abdominal/pelvic MRI provides greater anatomical detail and is recommended to more clearly define the length of the atretic segment between the lower and upper vaginas,<sup>74,75</sup> information that

is essential to planning surgical treatment. **The temptation to insert a needle for diagnostic purposes must be resisted to avoid the risk of seeding the contents with infection and converting a hematocolpos into a pyocolpos.** In rare instances, laparoscopy may be required to clarify the anatomy of the developmental anomaly. Transverse vaginal septum and cervical atresia may be accompanied by abnormalities of the upper reproductive tract, such as absent segments or atresia of the fallopian tubes or unilateral absence of the fallopian tube and ovary.<sup>76</sup> The chronic retrograde menstruation seen with transverse vaginal septum and cervical atresia is more exaggerated compared to imperforate hymen and frequently results in pelvic endometriosis and adhesions, which can be particularly severe.

Simply described, the procedure involves excision of the septum or dissection of the atretic segment and primary anastomosis of the margins of the lower and upper vaginal canals over the site of the defect. Atretic segments of greater length may require application of a graft to bridge the gap between the lower and upper vaginas. In all instances, every effort should be made to incise and drain the sequestered menstrual fluid from below, at the level of the obstruction. Even in complicated circumstances, continuity of the lower genital tract usually can be achieved successfully. Operative excision of painful masses from above risks damage to the bladder, ureters, and rectum and unnecessarily removes distended but otherwise healthy reproductive organs. Surgical management of a transverse vaginal septum can be challenging and, because they also are infrequently encountered, often requires consultation with specialists having the necessary training and experience. **Because septa that appear relatively thin by physical examination and MRI may be significantly larger after decompression of the proximal hematocolpos, preparations for surgery should consider the possibility that a graft may be required.**

The optimal surgical approach for the management of rare cases of cervical atresia is controversial. Ideally, the goal would be to preserve the uterus and fertility while creating a functional outflow for menstruation. But experience has proven that such heroic efforts may be associated with serious postoperative complications such as peritonitis and sepsis, recurrent obstruction, and persistent infertility, prompting many to view hysterectomy as the best management option. However, conservative surgical treatment is reasonable to consider in selected individuals. The best candidates are those recognized early, before they develop severe pelvic endometriosis and adhesions, having a well-developed lower vagina,<sup>77</sup> although successful reconstruction and pregnancy can be achieved even in those who also require vaginoplasty.<sup>78,79</sup>

## **Müllerian Agenesis (Mayer-Rokitansky-Küster-Hauser Syndrome)**

The failure of müllerian development is a relatively common cause of primary amenorrhea, much more frequently encountered than AIS discussed in the next section of this chapter, and second only to gonadal dysgenesis in prevalence.<sup>80</sup> In Finland, the incidence is approximately 1 in 5,000 newborn girls.<sup>81</sup> Although usually sporadic, some cases of müllerian agenesis are associated with chromosomal translocations or occur in familial aggregates, suggesting a genetic basis for the disorder.<sup>82</sup> Although the exact mechanisms remain unknown, studies on discordant monozygotic twins have offered some meaningful insights, implicating genes relevant to remodeling of the extracellular matrix and neoangiogenesis.<sup>83</sup> Logically, müllerian agenesis might be attributed to an activating mutation in the gene encoding antimüllerian hormone (AMH) or its receptor, causing excess AMH activity. Inactivating mutations in these genes causing persistence of müllerian structures in otherwise normally virilized males have been described.<sup>83,84,85</sup> However, no activating mutations have been identified in patients with müllerian agenesis. The prevalence of a mutation in the galactose-1-phosphate uridylyltransferase (GALT) gene (different from that associated with classical galactosemia) is increased in daughters with müllerian agenesis and their mothers.<sup>86</sup> This observation suggests that errors in fetal or maternal galactose metabolism resulting in increased intrauterine galactose exposure may have adverse effects on müllerian development and is consistent with studies in rodents wherein a high galactose diet during pregnancy delayed vaginal opening in the female offspring.<sup>87</sup> Given the relationship between classical galactosemia and POI (discussed later in this chapter), patients with müllerian agenesis who carry such a variant GALT gene mutation may be at increased risk for the same.<sup>88</sup>

Patients with müllerian agenesis typically present in late adolescence or as young adults, well after menarche was expected, with primary amenorrhea as their only complaint. **They exhibit normal, symmetrical breast and pubic hair development, have no visible vagina, and have no symptoms or signs of cryptomenorrhea because the rudimentary uteri contain no functional endometrium.** However, in approximately 10%, functional islands of endometrium may result in hematometra and symptoms of cyclic pain like described earlier in association with transverse vaginal septum or cervical agenesis.<sup>88,89</sup> Two forms of the disorder have been described. Type A is characterized by symmetrical, muscular, rudimentary uteri and normal fallopian tubes and type B by asymmetrical rudimentary uteri and absent or hypoplastic fallopian tubes.<sup>90</sup> In the great majority of patients with müllerian agenesis, the ovaries are entirely normal histologically and functionally, although their location in the pelvis may be higher, positioned at or even above the level of the pelvic brim; one or both also may be hypoplastic or associated with an inguinal hernia. Urologic anomalies are relatively common (15–40%), particularly in type B müllerian agenesis, and include unilateral

renal agenesis, ectopic or horseshoe kidney, and duplication of the collecting system(s).<sup>88,89</sup> Skeletal malformations involving the vertebrae, the ribs, or the pelvis are observed in 10–15% of patients with müllerian agenesis; some of the more common abnormalities include hemivertebrae leading to scoliosis and the Klippel-Feil syndrome, characterized by a short neck, low hairline, limited range of motion, and sometimes pain and neurologic symptoms, all relating to one or more fused cervical vertebrae.

Although the diagnosis of müllerian agenesis is suggested by clinical history and physical examination alone, additional evaluation is warranted to establish this diagnosis and to identify any of the associated urologic (renal ultrasonography) and skeletal anomalies (spinal x-rays) that may be relevant to the overall well-being of the patient. **Because patients with müllerian agenesis can exhibit characteristics similar to those observed in some types of male pseudohermaphroditism, a karyotype is justified and definitive.** In the absence of a karyotype, serum testosterone concentration in the normal female range effectively excludes AIS (discussed below). Pelvic imaging is indicated to quantify the anatomical defects when müllerian agenesis is suspected. Pelvic ultrasonography may help to define the size and symmetry of any pelvic reproductive organs, but pelvic MRI is more accurate and is indicated when doubt remains.<sup>91,92</sup> Laparoscopy usually is not necessary for establishing the diagnosis of müllerian agenesis. Although imaging frequently does not agree completely with surgical observations, detailed knowledge of the pelvic anatomy is not often needed.<sup>93</sup> Surgery generally is indicated only in those with symptoms relating to hematometra, endometriosis, or a hernia into the inguinal canal.

The primary goal of treatment in women with müllerian agenesis—creation of a functional vagina—can be accomplished with a variety of methods, when the time is appropriate. In the large majority of cases, progressive vaginal dilation as originally described by Frank<sup>94</sup> and later by others<sup>95</sup> is an appropriate and effective first choice. In motivated patients, the technique is highly successful and can create a functional vagina within 3–6 months.<sup>96</sup> The procedure involves applying pressure to the point of moderate discomfort for an interval of 20–30 minutes daily, using commercially available vaginal dilators. Initially, pressure is directed posteriorly, to create a shallow pouch. After approximately 2 weeks, pressure shifts to the usual axis of the vagina. After the desired depth is achieved, dilators of increasing diameter will expand the vagina to a functional size. A variation on the technique uses a tight-fitting garment to hold the dilator in place, maintaining pressure by leaning forward on a bicycle seat mounted on a stool, or even on a bicycle.<sup>97</sup>

Operative treatment of women with müllerian agenesis generally can be reserved for those who are unable or unwilling to dedicate themselves to a program of

progressive vaginal dilation and for those in whom earnest efforts fail. The traditional McIndoe procedure for surgical creation of a neovagina involves dissection of the rectovaginal space and placement of a skin graft, held in place with a soft mold until the graft becomes established.<sup>98</sup> Subsequently, regular intercourse or vaginal dilation must be maintained to avoid risk of fibrosis and loss of function. The alternative Vecchiotti operation involved internal stretching of the vaginal dimple after surgical abdominal and vaginal dissection of the vesicorectal space.<sup>99</sup> A modification of the Vecchiotti operation, performed laparoscopically, has emerged as an attractive and effective option for surgical creation of a neovagina.<sup>100,101</sup> The procedure employs a specially designed system including a spring-loaded traction device, positioned on the abdomen; connected to the tip of a dilator; positioned at the introitus, via paired threads introduced with a needle inserted through small incisions in the lower abdomen; and guided beneath the peritoneum to penetrate the introitus in the midline. Tension on the threads is adjusted to maintain traction on the dilator, which is drawn upward gradually, invaginating the tissue to produce a neovagina 7–8 cm in depth over an interval of 7–10 days. Thereafter, standard vaginal dilators are employed to further extend and expand the vagina to functional dimensions over a period of a few weeks. Evidence indicates that the procedure results in a quality of sexual experience comparable to that in a sample of healthy, age-matched women of equivalent cultural and social status.<sup>102</sup>

Reassurance and support are important elements of the management of vaginal/müllerian agenesis. Affected women should be counseled that normal sexual function can be expected. Advances in assisted reproductive technologies with the use of gestational surrogacy option have allowed attainment of genetic offspring by in vitro fertilization (IVF) using oocytes retrieved from their own normal ovaries and the sperm of their chosen partner, with subsequent transfer of embryos to a gestational surrogate.<sup>102,103,104</sup> Existing data on neonatal outcomes of IVF with autologous eggs from patients with müllerian agenesis and use of gestational surrogates offer reassurance against any evidence of a dominant pattern of inheritance.<sup>104</sup> In the past decade, uterine transplantation has moved leaps and bounds, from concept to a reality, and may even eventually emerge as a first-line approach for addressing reproductive needs for patients with müllerian agenesis.<sup>105,106</sup>

## **Androgen Insensitivity Syndrome (AIS)**

Complete AIS (testicular feminization) is a form of male pseudohermaphroditism, the term referring to the gonadal sex (male) and the contrasting phenotype (female).<sup>107,108</sup> The disorder, discussed in greater detail in [Chapter 8](#) as a cause of abnormal sexual development, is the third most common cause of primary amenorrhea, after gonadal dysgenesis and müllerian agenesis. Patients with AIS have a normal male karyotype

(46,XY) and testes as gonads that produce both testosterone and AMH. However, an inactivating mutation in the gene encoding the intracellular androgen receptor (AR) (located on the long arm of the X chromosome, Xq) results in an end-organ insensitivity to androgen actions that prevents normal masculinization of the internal and external genitalia during embryonic development. Consequently, in the absence of androgen action, differentiation of the external genitalia follows the “default” female pattern of development. However, given AMH signaling is intact in AIS, the internal genitalia follow the male pattern of differentiation with regression of the müllerian structures; individuals with AIS are phenotypic females with absent cervix and uterus (due to normal AMH action); the vagina is short and ends blindly (derived only from the urogenital sinus).

Patients with complete AIS appear as normal females at birth. Growth and development during childhood also are generally normal, although overall height usually is above average and the body habitus somewhat eunuchoid (long arms, large hands and feet). At puberty, the breasts develop, driven by estrogen derived from the peripheral conversion of high circulating testosterone levels, unopposed by the actions of androgen. The breasts may become relatively large and have subtle abnormalities; lacking the actions of progesterone, they have little glandular tissue, small nipples, and pale areolae. The labia minora usually are underdeveloped and the vagina is short and ends blindly. Pubic and axillary hair do not develop, due to the absence of androgen action. The gonads are testes, and their location may be intra-abdominal, but often are partially descended into the inguinal canal; more than half of patients with complete AIS have an inguinal hernia, and the testes are frequently palpable in the inguinal canals, most commonly at the level of the external inguinal ring. Histologically, the gonads generally resemble any cryptorchid testes but may be nodular. After puberty, the testes contain immature seminiferous tubules lined by immature germ cells and Sertoli cells, with no evidence of spermatogenesis.

Patients with complete AIS most commonly present after the age of puberty in late adolescence or as young adults with primary amenorrhea. **They exhibit asymmetrical secondary sexual development (breast development with absent or scant pubic hair), have a short vagina with no visible cervix, and have no other symptoms or complaints.** Uncommonly, AIS may be recognized at birth or in childhood during workup for an inguinal mass or hernia, particularly when the disorder is reasonably suspected because other family members such as a sister or maternal aunt are affected. Diagnosis usually is not difficult. Patients with complete AIS generally are easily distinguished from those with müllerian agenesis by the absence of pubic and axillary hair and from those with an imperforate hymen or transverse vaginal septum by the absence of a uterus and lacking symptoms relating to obstructed menstrual flow. In some cases, the presence of some pubic hair, due to incomplete penetrance, can be confusing

or misleading. **Serum testosterone concentration easily distinguishes patients with AIS from those with müllerian agenesis because levels are normal or modestly elevated well above the normal range for females and often above the range observed in normal males.** Serum LH levels also are elevated, reflecting androgen insensitivity at the hypothalamo-pituitary level. A karyotype (46,XY) firmly establishes the diagnosis.

In rare cases of **incomplete androgen insensitivity**, varying degrees of androgen signaling remain. Consequently, depending on the magnitude of androgen sensitivity, the condition may present as ambiguous genitalia at birth; in more subtle cases, at puberty, pubic hair growth may accompany breast development and the clitoris may enlarge.<sup>107</sup> In other rare individuals, inherited deficiency of the enzyme **17-hydroxysteroid dehydrogenase** (type 3), which catalyzes the conversion of androstenedione to testosterone in the testicular Leydig cells, may mimic AIS; in this case however, the mechanism is one of impaired testosterone production rather than abnormalities in the AR and androgen signaling. When necessary, the two disorders can be differentiated by molecular analysis of the genes encoding the AR and the enzyme (17HSDB3).<sup>109</sup>

The management of patients with complete AIS has two major components, one focusing on creation of a functional vagina to allow attainment and optimization of potential for sexual relations and another relating to the risk for developing malignancy in the cryptorchid testes. In patients with AIS, the options for creation of a neovagina are the same as discussed earlier for those with müllerian agenesis—progressive vaginal dilation and vaginoplasty. The short but distinct vagina observed in most patients with AIS speeds the progress of efforts at vaginal dilation. Good results also can be expected with surgical treatment, when necessary.<sup>110</sup> Gonadectomy is indicated because the incidence of neoplasia in cryptorchid testes is relatively high. In one early series of 50 cases, 11 malignancies, 15 adenomas, and 10 benign cysts were observed: a 22% incidence of malignancy and a 52% overall incidence of neoplasia.<sup>111</sup> More recent series suggest a lower 5–10% overall incidence of gonadal tumors.<sup>52,112,113</sup> Whereas gonadectomy is recommended at the time of diagnosis in other intersex states such as XY gonadal dysgenesis (Swyer syndrome), it is better delayed in those with AIS, for two reasons. First, the smooth pubertal development that results from endogenous gonadal hormone production is difficult to achieve with exogenous hormone treatment, and second, gonadal tumors develop less often in patients with AIS and rarely before puberty. Therefore, gonadectomy and hormone therapy (physiologic estrogen treatment) generally are best postponed until after pubertal development is complete, by approximately age 16–18. **Complete AIS is the only exception to the rule that gonads with a Y chromosome should be removed as soon as the diagnosis is made.** Gonadectomy usually can be accomplished endoscopically with relative ease when the

testes reside within the abdomen and via inguinal incisions when they are partially descended.<sup>114,115</sup> In patients with the incomplete form of AIS, surgery should not be postponed because prompt gonadectomy will prevent further unwanted virilization that can occur at puberty.

In years now past, conventional wisdom warned against unthinking and “needless” disclosure of the true gonadal and chromosomal sex to patients with complete AIS for fear of undermining gender identity; this attitude has changed in favor of disclosure. Although infertile, patients with AIS have a completely female gender identity that must be reinforced, and not questioned. Candid disclosure based on facts and communicated with extreme sensitivity is advocated. Patients as well as parents must be offered psychological counseling and allowed access to educational resources to facilitate a fuller understanding of the disorder. One excellent resource is the Androgen Insensitivity Syndrome Support Group, headquartered in the United Kingdom (<http://www.aissg.org/>). Another resource is available through the NIH U.S. Library of Medicine (<https://ghr.nlm.nih.gov/condition/androgen-insensitivity-syndrome>).

## **Cervical Stenosis**

Severe cervical stenosis with complete outflow obstruction is a rare complication of cervical conization procedures or other surgical treatments for cervical intraepithelial neoplasia. When cervical stenosis causes symptoms, worsening dysmenorrhea and prolonged light staining or spotting after menses are the most common complaints; amenorrhea is a rare occurrence. Compared to other methods for limiting blood loss during conization, elective suturing appears to increase the risk for subsequent cervical stenosis and amenorrhea.<sup>116</sup> In women with amenorrhea who have had a previous conization or other cervical surgery or ablative treatment, simple uterine sounding will establish the diagnosis of cervical stenosis, and transvaginal ultrasonography will reveal any associated hematometra. The treatment for cervical stenosis is careful dilation, ideally performed under ultrasound guidance, although cervical dilation under fluoroscopic guidance has also been described.<sup>117</sup> Temporary placement of a urinary or specialized balloon catheter for an interval of approximately 2 weeks provides ongoing drainage of the uterine cavity and may help to prevent recurrence.<sup>118</sup>

## **Asherman Syndrome (Intrauterine Adhesions)**

Asherman syndrome, first described by Joseph Asherman in 1948 and called “amenorrhoea traumatica,”<sup>119</sup> results from intrauterine adhesions that obstruct or obliterate the uterine cavity, because of trauma. Disruption of the full thickness of the endometrium including the zona basalis, commonly resulting from instrumentation of the uterine cavity, is the most common mechanism for intrauterine scarring. Risk for



developing intrauterine adhesions is increased by inflammation, as may result from endometritis or retained products of conception, and when the endometrium is relatively thin and inactive, as it is during the early postpartum period. Consequently, most cases arise in close temporal proximity to a pregnancy and are associated with surgical trauma, primarily curettage.<sup>120</sup> In the original series of 29 cases described by Asherman, 11 had a previous postpartum hemorrhage, 15 experienced spontaneous abortion, 2 had undergone an elective pregnancy termination, and in 1, the antecedent event was a hydatidiform mole.<sup>119</sup> Asherman syndrome is an uncommon but recognized complication of cesarean section, abdominal or hysteroscopic myomectomy or metroplasty, and uterine artery embolization.<sup>121</sup> Elective endometrial ablation procedures that utilize various modalities to achieve endometrial damage such as electrocautery, laser, thermal ablation, or cryoablation for the management of menorrhagia frequently result in amenorrhea, by intent. End-organ endometrial damage and intrauterine adhesions also may result from intrauterine infections such as tuberculosis and schistosomiasis, which are rare in the United States but not in other regions of the world.<sup>122,123</sup>

Although Asherman syndrome from any cause may result in amenorrhea, most women with intrauterine adhesions present with dysmenorrhea, hypomenorrhea, infertility, or recurrent pregnancy loss, rather than absence of menses. **The diagnosis of Asherman syndrome is based primarily on a high index of suspicion, based on history. In women whose history suggests this possibility, scant or no withdrawal bleeding after sequential treatment with exogenous estrogen (e.g., conjugated equine estrogens 1.25 mg daily for 21 days) and progestin (e.g., MPA 10 mg daily for the last 5–7 days of estrogen dosing) reflects end-organ endometrial failure and corroborates the clinical suspicion.** However, some form of imaging ultimately is required to establish the diagnosis. Transvaginal or transabdominal ultrasonography may reveal a hematometra, but such findings are surprisingly rare. The clinical impression is further strengthened by ultrasound evidence of a thin, hyperechoic, and often irregular endometrial echo. Saline infusion sonogram (SIS) or hysterosalpingography (HSG) provides more specific information regarding the location and extent of intrauterine adhesions that partially or completely obliterate or obstruct the endometrial cavity or the cervical canal.<sup>124</sup> Hysteroscopy provides a definitive diagnosis. A variety of classification schemes have been proposed to describe the extent of intrauterine adhesions and to predict treatment outcomes,<sup>125,126,127,128,129,130</sup> but none has been validated. Diagnosis of genital tuberculosis is made by endometrial biopsy (histopathology or culture) or with a nucleic acid–based test performed on an endometrial aspirate. Diagnosis of schistosomiasis is made by identifying the eggs of the parasite in urine, feces, rectal scrapings, menstrual discharge, or the endometrium.

Operative hysteroscopy is the primary method for treatment of intrauterine

adhesions. Hysteroscopic adhesiolysis can be performed using hysteroscopic scissors, electrodissection, or with a laser; most prefer sharp dissection, which may have less risk for causing further injury. Simultaneous laparoscopy or transabdominal ultrasonography provides useful guidance when dense scar tissue makes it difficult to enter the uterine cavity and can help to maintain orientation within a grossly distorted cavity, reducing the risk of uterine perforation. Postoperative risk for rescarring is high; most advocate the insertion of an intrauterine balloon catheter (left in place for approximately 7–10 days) after adhesiolysis to keep the walls of the uterine cavity separated during the healing process to decrease the risk of recurrence.<sup>131</sup> Treatment with a broad-spectrum antibiotic (e.g., doxycycline 100 mg twice daily or Augmentin 500 mg twice daily) to minimize risk of infection during the period that balloon is retained and a nonsteroidal anti-inflammatory drug to reduce uterine cramping while the catheter remains in place are commonly utilized. High-dose exogenous estrogen treatment (2.5 mg conjugated equine estrogens 2–3 times daily or its equivalent) for approximately 4 weeks after surgery is generally recommended to encourage rapid endometrial re-epithelialization and proliferation; treatment with a progestin during the final week, if followed by menses, demonstrates a return of functional endometrium. Despite these measures, recurrence rates are relatively high, ranging from 20% to over 60% in severe cases,<sup>132</sup> and repeated procedures often are required to restore a normal uterine cavity.<sup>133</sup> The surgical outcome can be assessed by postoperative SIS or HSG or by early “second-look” hysteroscopy, which also provides the means to lyse any early recurring adhesions when still filmy.<sup>120</sup> Menstrual function can be restored in most cases (52–88%),<sup>132</sup> and among infertile women, live birth rates after hysteroscopic adhesiolysis generally have ranged between 25% and 35%.<sup>133</sup> As might be expected, outcomes tend to correlate with the severity of adhesions.<sup>127,132,134</sup> In those who do achieve pregnancy, the risks of preterm labor, placenta accreta, placenta previa, and postpartum hemorrhage are increased.<sup>127,134</sup> A recent development in the management of Asherman syndrome involves efforts at restoration of the endometrial uterine stem cell population through strategies that have ranged from systemic mobilization of the bone marrow–derived stem cells with the use of GCSF (granulocyte colony–stimulating factor) to intrauterine and intravascular injection of bone marrow aspirate into uterine vessels. Although experimental evidence is highly promising and anecdotal successes with endometrial restoration have also been achieved in clinical settings, the concept and technique both need to be refined before this approach can be made available for routine clinical applicability.<sup>135,136</sup>

# Disorders of the Ovary

Disorders of the ovary include the most common causes of amenorrhea and can present as primary or secondary amenorrhea. Those resulting only from chronic anovulation and relating to PCOS, obesity, and thyroid or mild prolactin excess disorders were discussed earlier in the section of this chapter devoted to the evaluation of ovarian function. The focus here is on specific disorders that result in ovarian failure and their management.

Ovarian failure occurs when few or no follicles remain that are capable of producing estradiol in response to pituitary gonadotropin stimulation. Follicular depletion may occur during embryonic life with no follicles remaining by infancy or early childhood, after puberty has begun but before menarche, or at some later time before menopause normally would be expected. Consequently, depending on when the available supply of ovarian follicles is functionally depleted, puberty may not occur, it may begin normally but stop before the first menses, or it may progress normally to and beyond menarche with the development of secondary amenorrhea at some later point in time. Regardless of age at onset, hypergonadotropic hypogonadism is the biochemical hallmark of ovarian failure. In a few women with rare genetic disorders however, a picture of hypergonadotropic hypogonadism results from a functional ovarian failure due to abnormalities in gonadotropic signaling and of ovarian follicular development, rather than from ovarian follicular depletion.

## Gonadal Dysgenesis

Gonadal dysgenesis is defined as an incomplete or defective formation of the gonads, resulting from a disturbance in germ cell migration or organization. Commonly caused by structural or numerical sex chromosome abnormalities or mutations in the genes involved in formation of the urogenital ridge and sexual differentiation of the bipotential gonad, gonadal dysgenesis is among the most common causes of primary amenorrhea (approximately 30–40%). Due to the absence of ovarian follicles or their accelerated depletion during embryogenesis or the first few years of life, the gonads in cases of pure gonadal dysgenesis contain only stroma and appear as fibrous streaks. The large majority of women with gonadal dysgenesis have an obvious abnormality involving an X chromosome. Approximately 25% of the affected individuals however have a normal 46,XX karyotype; this population may harbor a more subtle abnormality involving one or more specific genes on the X chromosome that are required for normal ovarian function. Some with 46,XX gonadal dysgenesis also have neurosensory deafness; the combination is known as Perrault syndrome. By far, the most common known form of gonadal dysgenesis is seen in cases of Turner syndrome.

# Turner Syndrome

Turner syndrome is a well-known and thoroughly studied genetic disorder, classically associated with a 45,X karyotype, but also with an assortment of other structural X chromosome abnormalities (deletions, ring, and isochromosomes), any of which may be present in all or only in some of the somatic cells (mosaicism), depending on the stage of embryonic development at the time the genetic defect arises. The disorder is discussed thoroughly in [Chapter 8](#), as a cause of abnormal sexual development, and is briefly summarized here.

The classical phenotype of Turner syndrome, first described in 1938 by Dr. Henry Turner, includes short stature, absent sexual development, a webbed neck, low-set ears and posterior hairline, widely spaced nipples (“shield chest”), short fourth metacarpals, and an increased carrying angle at the elbow (“cubitus valgus”). Evidence indicates that the specific phenotype of patients with Turner syndrome relates, in part, to the parental origin of their single X chromosome; most with a 45,X karyotype retain the maternal X.<sup>137</sup>

**If not recognized by phenotype or poor growth during childhood, patients with Turner syndrome generally present at or near the time of expected puberty with primary amenorrhea and absent secondary sexual development.** The diagnosis of Turner syndrome generally can be made easily, based on the phenotype and findings of hypergonadotropic hypogonadism. A karyotype is definitive, and specifically indicated, in part because it may reveal a cell line containing a Y chromosome otherwise not suspected or identified (e.g., 45,X/46,XY); approximately 5% of women with Turner syndrome have a karyotype containing all or part of a Y chromosome.<sup>138</sup> Further analysis with fluorescence in situ hybridization (FISH) using one or more probes specific for segments of the Y chromosome will identify another 5% having occult Y chromosome material.<sup>138,139</sup> Whereas it is important to identify a Y chromosome because affected individuals are at significant increased risk for developing gonadoblastoma (20–30%), that risk appears lower (5–10%) in women with Turner syndrome and limited to those having detectable Y chromosome on karyotype. **FISH analysis is most clearly indicated for those exhibiting any evidence of virilization or having a chromosomal fragment of uncertain origin** (discussed in [Chapter 8](#)).<sup>139,140</sup>

Mosaicism in women with Turner syndrome has important clinical implications besides those relating to a cell line containing a Y chromosome. In those with a mosaic 46,XX cell line (e.g., 45,X/46,XX), the gonad may contain functional ovarian cortical tissue, resulting in some degree of sexual development, or even menses and the possibility of pregnancy. Approximately 15% of patients with Turner syndrome begin but do not complete pubertal development and approximately 5% complete puberty and

begin menstruation.<sup>141</sup> As might be expected, given the genetic heterogeneity, the phenotype varies, with some appearing normal without obvious phenotypic stigmata and even attain normal stature before experiencing ovarian failure.

Women with Turner syndrome are at risk for a wide variety of medical problems having health implications that are equal if not more important than those relating to or resulting directly from hypogonadism.<sup>138</sup> Approximately one-third manifest one or more of a spectrum of cardiovascular anomalies that have been described in women with Turner syndrome and include bicuspid aortic valve, coarctation of the aorta, mitral valve prolapse, and aortic aneurysm. Spontaneous aortic dissection is a real risk in women with Turner syndrome, which gets exaggerated if pregnancy occurs, and is associated with a high incidence of mortality. Renal anomalies are also common and include horseshoe kidney, unilateral renal agenesis or pelvic kidney, rotational abnormalities, and partial or complete duplication of the collecting system(s). The prevalence of autoimmune disorders is common in Turner syndrome including autoimmune thyroiditis, type I diabetes, autoimmune hepatitis, thrombocytopenia, and celiac disease.<sup>142,143,144</sup> Hearing loss also is also common in this population and sensorineural loss is the most common form of hearing impairment in this population.<sup>145</sup> **Consequently, additional and periodic medical evaluation is indicated and should include the following<sup>140,145</sup>:**

- **Echocardiography (at diagnosis, at least once between the ages of 12 and 15 years, and every 5 years if normal; more often if abnormal)**
- **Renal ultrasonography (once if normal, every 3–5 years if abnormal)**
- **TSH and free T4 (at diagnosis and every 1–2 years)**
- **Complete blood count, fasting glucose, lipid profile, renal function tests, and liver enzymes (every 2 years)**
- **Antiendomysial antibodies, to detect celiac disease (at diagnosis)**
- **Audiometry (at diagnosis, at least once during the teen years or young adulthood, and every 10 years if normal)**

Average intellectual performance is within the normal range, although the prevalence of attention-deficit/hyperactivity disorder (ADHD) is increased in girls with Turner syndrome.<sup>146,147</sup> Overall mortality is increased approximately threefold and relates primarily to circulatory disease (e.g., hypertension), diabetes, and liver and renal disease.<sup>148</sup> Overall cancer risks in women with Turner syndrome are similar to those in the general population, but the incidence of CNS tumors, bladder cancer, and endometrial cancer may be increased<sup>149</sup>; the risk of breast cancer is decreased compared to the general population and may be attributable to the early deprivation of

ovarian hormones.<sup>149</sup> With early diagnosis and treatment with growth hormone (GH), a final height greater than 150 cm (59 inches) can be achieved in most patients with Turner syndrome. The most important determinants of final height are the dose of GH and the duration of treatment before estrogen therapy begins. Treatment with GH generally should begin as soon as growth curve falls below the fifth percentile of normal female growth, and the regimen must be individualized, according to response.<sup>140</sup>

Treatment with estrogen must be timed carefully, with the goals of minimizing its adverse effects on growth and adult height and inducing puberty at an approximately normal age. Ideally, estrogen therapy should begin no later than age 15 and not before age 12 when growth is a priority, unless height already has been maximized. Estrogen therapy should begin at a low dose (e.g., 0.25–0.5 mg micronized estradiol or its equivalent), increasing gradually at intervals of 3–6 months according to response (Tanner stage, bone age), with the goal of completing sexual maturation over a period of 2–3 years. When vaginal bleeding first occurs, or after 12–24 months of estrogen therapy, a progestin (e.g., MPA) should be added to the treatment regimen to prevent dysfunctional bleeding, to achieve differentiation of breast tissue, and to protect the endometrium from long-term adverse effects of unopposed estrogen.<sup>140</sup> Natural pregnancies are described in women with Turner syndrome, but they are rare and are associated with a relatively high risk for sex chromosome aneuploidy and spontaneous abortion. For the majority of women with Turner syndrome, oocyte donation offers a realistic possibility of biologic parenting. Any pregnancy in a woman with Turner syndrome must be considered as high risk given the innately increased cardiovascular risk related to structural cardiac anomalies that this population is predisposed to. The increased cardiovascular demands of pregnancy pose unique and potentially life-threatening risks that must be carefully considered before attempting pregnancy. **The risk of death during pregnancy is increased as much as 100-fold, primarily due to complications of aortic dissection or rupture.** This risk is greatest for those with preexisting cardiac abnormalities such as a bicuspid aortic valve or a dilated aortic root, but even those without obvious cardiac abnormalities remain at risk. **Turner syndrome generally should be regarded as a relative contraindication to pregnancy.** Those expressing serious interest in oocyte donation must receive thorough evaluation and counseling, and those with evidence of any significant cardiac abnormality must be strongly discouraged.<sup>150</sup> Advances in the field of fertility preservation, such as oocyte or ovarian tissue cryopreservation, now can offer a realistic possibility for preservation of fertility potential for a subset of girls and women with Turner syndrome who demonstrate evidence of residual ovarian function<sup>151</sup>; eggs and embryos of these patients are at a higher risk for sex chromosome aneuploidy, and preimplantation genetic screening technology can be utilized to minimize the risk of aneuploidy in the progeny.

Despite the promise, these technologic advancements in the field of assisted reproduction are likely to offer benefit to only a fraction of patients with Turner syndrome, the majority are destined for prepubertal or peripubertal ovarian failure. Consideration for use of gestational surrogate should be strongly encouraged for women considering use of donor eggs or by those who have autologous cryopreserved eggs or ovarian tissue.

## Swyer Syndrome (46,XY Gonadal Dysgenesis)

Swyer syndrome is a distinctly different and less common form of gonadal dysgenesis that is characterized by a 46,XY karyotype. Despite the presence of a Y chromosome, the phenotype is female because the dysgenetic (streak) gonads produce neither AMH nor androgens. Consequently, the vagina, cervix, uterus, and fallopian tubes develop normally and the internal and external genitalia fail to masculinize.<sup>152</sup> In at least 10–15% of the affected individuals, a mutation of the SRY (Sex-determining Region of the Y chromosome) gene that is located on the short arm of the Y chromosome (Yp11.3) is the cause.<sup>153</sup> In the remainder, no cause can be determined, although mutations in the SRY regulatory elements or in other genes involved in the testis-determining pathway have been implicated (SF1, SOX9, WT1, CMRT1).<sup>154,155,156</sup>

**Patients with Swyer syndrome generally present after the expected time of puberty with delayed sexual maturation and primary amenorrhea.** The presence of pubic hair reflects a normal adrenarche and hence rules out complete AIS as a possible diagnosis. Evaluation reveals hypergonadotropic hypogonadism, prompting a karyotype that establishes the diagnosis. **Gonadectomy is indicated soon after diagnosis is made due to the significant risk for malignant transformation in occult testicular elements (20–30%).** Gonadoblastoma is a premalignant germ cell tumor, unique to intersex states like Swyer syndrome, and may contain or give rise to other highly malignant tumors, including dysgerminoma, endodermal sinus tumor, embryonal carcinoma, and choriocarcinomas; evidence suggests that the tumors originate from clonal expansion of surviving germ cells in areas of undifferentiated gonadal tissue.<sup>157</sup>

Patients with Swyer syndrome exhibit normal growth and intellectual development, are otherwise healthy, and require no specific monitoring or treatment beyond that relating to hormone therapy aimed at inducing sexual maturation. The same sequential sex steroid treatment regimen described above for patients with Turner syndrome can be applied successfully in those with Swyer syndrome. Despite the male karyotype, the patients with Swyer syndrome must be assured of their female gender identity and reassured regarding their ability to achieve and sustain a pregnancy with the use of donor egg IVF. Unlike the situation with Turner syndrome patients, pregnancy in patients with Swyer syndrome has not been associated with any specific risks or

complications.<sup>158</sup>

## **46,XX Gonadal Dysgenesis**

Some individuals with primary amenorrhea and gonadal dysgenesis (streak gonads) have a normal 46,XX karyotype, providing indirect evidence that autosomal genes also play a critical role in ovarian differentiation. In contrast to those with Turner syndrome, affected women are normal in stature and, in most cases, have no apparent somatic anomalies. A wide variety of candidate genes has been identified, primarily via experiments involving murine knockout models, including several that encode DNA- and RNA-binding proteins and transcription factors expressed during oogenesis.<sup>159</sup>

## **Premature Ovarian Failure or Premature Ovarian Insufficiency**

POF is traditionally defined as hypergonadotropic hypogonadism and amenorrhea arising before the age of 40. This is a heterogeneous disorder that varies widely in cause and phenotype. Whereas the term POF is well-entrenched in the medical literature, an alternative term—“premature ovarian insufficiency” or POI—has been proposed and increasingly adopted to more accurately reflect the continuum of decreased ovarian function observed in the affected women<sup>160</sup> while acknowledging that many may exhibit intermittent ovarian function and ovulation and that 5–10% may even conceive and achieve successful live birth.<sup>161,162</sup> In this chapter, terms POF and POI are used interchangeably.

Although POI can manifest at any age, the majority of cases present as secondary amenorrhea at some time after puberty is completed; it however also may occur at any time before menarche and is then distinguished from gonadal dysgenesis on the basis of ovarian morphology and histology; instead of streak gonads, the ovaries more closely resemble those of menopausal women. Approximately 1% of women will develop POI before the age of 40 years. In a cross-sectional survey of women aged 40–55 conducted at seven sites in the United States to determine eligibility for a community-based, multiethnic longitudinal study of the perimenopause (the Study of Women Across the Nation, SWAN), premature menopause was reported by 1% of Caucasians, 1.4% of African Americans and Hispanics, 0.5% of Chinese, and 0.1% of Japanese women.<sup>163</sup>

Important known causes of POI include numerical and structural chromosomal abnormalities, fragile X (FMR1) premutations, autoimmune disorders, radiation therapy, and chemotherapy. Whereas history alone can identify the latter two, the first three merit specific consideration and exclusion. In these and other rare disorders associated with ovarian failure such as galactosemia, the basic pathophysiology



involves accelerated follicular atresia. In other rare genetic disorders, mutations in genes encoding intraovarian regulators, steroidogenic enzymes, gonadotropins, or their receptors result in impaired or abnormal follicular development, but the end result is much the same—functional ovarian failure. In most women with POF, a specific cause cannot be identified, but evidence implicating a number of genetic factors is growing rapidly.<sup>159</sup>

## **Numerical and Structural Chromosomal Abnormalities**

A wide variety of numerical and structural chromosomal abnormalities may be identified in women presenting with POI. A review of karyotypes obtained in women with secondary amenorrhea revealed the spectrum of possibilities and demonstrates the importance of a karyotype in women with POF.<sup>164</sup> Half of the observed abnormalities were numerical, involving X chromosome mosaicism (including 45,X, 46,XX, and 47,XXX cell lines) or Y chromosome mosaicism (including 46,XY, 47,XYY, and 47,XXY cell lines); the remainder included an assortment of X chromosome translocations, deletions, and other structural abnormalities and even some with a pure 46,XY karyotype.

Chromosomal deletions and translocations involving either the short (Xp) or the long arm (Xq) of the X chromosome may be identified in women with POF. Only about half of those with deletions involving the short arm of the X chromosome present with primary amenorrhea and gonadal dysgenesis; the remainder achieve menarche and exhibit cyclic ovarian function reflected in menstruation for variable lengths of time before experiencing POF and secondary amenorrhea. Presumably, the short arm of the X chromosome contains genes essential for ovarian germ cell function. Although the specific genes involved are unknown, likely candidates include BMP15 (Bone Morphogenetic Protein) and other members of the TGF $\beta$  (Transforming Growth Factor Beta) superfamily.<sup>159</sup> The long arm of the X chromosome also contains genes crucial for normal ovarian function. Likely candidate genes, identified by the phenotypes associated with deletions and translocations involving Xq, include XIST (the X-inactivation gene), DACH2 (encoding a transcription factor), and QM (encoding a ribosomal protein).<sup>159,165</sup>

## **Fragile X (FMR1) Premutations**

A spectrum of clinically important disorders, including POI, involves a dynamic trinucleotide (CGG) repeat sequence mutation in the X-linked FMR1 gene, located near the terminal end of the long arm of the X chromosome (Xq27.3). As mentioned earlier in this chapter, the normal FMR1 gene contains approximately 30 repeats. The fully expanded form of the mutation, characterized by 200 or more CGG repeats, results in

FXS, the most common known genetic cause of mental retardation and autism. The premutation, characterized by between 55 and 200 trinucleotide repeats, is associated with two disorders that are distinct from FXS. One is the fragile X-associated tremor/ataxia syndrome (FXTAS), a neurologic disorder that affects males primarily, as might be expected for an X-linked disorder. The other is POF, affecting approximately 15% of women who carry the premutation.<sup>59,60</sup>

In the full mutation, the expanded number of trinucleotide repeats in the 5' untranslated region of the FMR1 gene results in hypermethylation that extends into the promoter region and silences the gene. Consequently, there is little or no production of mRNA and its product, the FMRP, which is an RNA-binding protein that functions as a translational suppressor. Ultimately, the result is an overexpression of mRNAs, leading to the clinical features of FXS.<sup>166</sup> The incidence of FXS is approximately 1 in 4,000 males and 1 in 4,000–8,000 females.<sup>59,60</sup> Although affected females are protected to some extent from the full impact of the mutation, due to the phenomenon of X-inactivation, approximately 70% have a borderline or lower IQ or other functional deficits.<sup>167,168,169</sup>

In the setting of premutation, the trinucleotide repeat sequence is not methylated, the FMR1 gene is functional, and FMRP is produced. However, the condition is quite different from the usual unaffected carrier state in two important ways: (1) premutation carriers are at risk for developing disorders that are distinct from FXS, and (2) the affected alleles are unstable and at risk for expansion from the premutation to the full mutation. FXTAS is a progressive neurodegenerative disorder affecting male premutation carriers, generally after age 50, causing intention tremor, ataxia, autonomic dysfunction, cognitive deficits, behavioral abnormalities, and peripheral neuropathy.<sup>170</sup> Female premutation carriers may develop the disorder, but do so infrequently; unfavorable X chromosome inactivation may increase the risk of FXTAS in women.<sup>171</sup> However, women with a FMR1 premutation frequently develop POF. The prevalence of premutations is approximately 15% among women with familial POF and lower, but still significant (1–7%), in those having no family history of POF.<sup>59</sup> The variation in prevalence may be explained by the relationship between the probability of POF and the size of the CGG repeat sequence; risk for POF increases with the number of repeats, between 59 and 99, but rises no further and even decreases for those with more than 100 repeats.<sup>172,173</sup> Women with a modestly expanded repeat sequence (41–58 repeats) also may be at increased risk for POF.<sup>174,175</sup>

Women who carry the FMR1 premutation often exhibit signs of early reproductive aging. The lengths of their menstrual cycles and the follicular phase of the cycles are shorter, FSH levels across all phases of the cycle are higher, and inhibin levels are lower, compared to those in normal women,<sup>176</sup> and an inverse correlation was

demonstrated between length of CGG repeats and AMH levels.<sup>177</sup> Premutation carriers also enter menopause approximately 5 years earlier than average.<sup>172</sup> Exactly why or how the FMR1 premutation predisposes to POF is not entirely clear but may involve gain-of-function toxicity, due to overexpression of mRNAs, resulting in accelerated follicular atresia.

The inheritance of FMR1 mutations and premutations follows the basic pattern of an X-linked disorder; the carrier females transmit the abnormality to 50% of their offspring (sons and daughters), whereas the male carriers transmit the affected allele to 100% of their daughters, while the sons get spared. The pattern of inheritance is complicated by the meiotic instability of the trinucleotide repeat sequence, which tends to expand when passed from the mother to her progeny, thereby increasing the risk for FXS with each successive generation, a phenomenon known as “anticipation.” The risk for expansion depends on the size of premutation; a repeat sequence numbering between 59 and 79 expands to the full mutation range less than half the time, but trinucleotide repeat counts greater than 90 do so more than 90% of the time.<sup>178</sup> In contrast, the size of the premutation remains relatively stable when transmitted from fathers to their daughters and rarely expands to the full mutation,<sup>179</sup> possibly because large repeat sequences are highly unstable in the developing sperm and only smaller premutations can be transmitted. Intermediate or “gray zone” repeat sequences numbering between 45 and 54 may expand to premutation size across generations. **Due to the complexity of the inheritance of FMR1 premutations, all carriers should receive formal genetic counseling.** Issues that must be addressed include the risk for infertility and of early menopause, the risk for and implications of transmitting the premutation to the next generations, and the possibility that other family members may be affected, in a variety of ways, raising still other and obvious ethical concerns.

**All women with POF should be offered screening for the FMR1 premutation.** In sum, guidelines issued by the American College of Medical Genetics, the American College of Obstetricians and Gynecologists, and the American Society for Reproductive Medicine all recommend FMR1 testing for women with unexplained POF.<sup>59,180</sup> **There is consensus that testing should be offered to those having a family history of POF, FXS, or FXTAS or having relatives with unexplained mental retardation or autism. Additionally, screening merits consideration in women demonstrating evidence of diminished ovarian reserve.**<sup>181</sup> Arguments against more liberal or widespread population screening center on the limited resources available to provide the complicated counseling required and the uncertainties surrounding the risks associated with alleles in the intermediate range, which are common.

Up to 5–10% of women with POI who carry an FMR1 premutation will conceive after diagnosis, without medical intervention, but there is no evidence that any treatment

other than oocyte donation can increase the likelihood of pregnancy.<sup>162</sup>

## Autoimmune Disorders

Autoimmune disease is one of the known causes of POI, accounting for approximately 4% of cases.<sup>62,63,159,160</sup> There is substantial evidence to indicate that autoimmunity is the cause of POF in women who also exhibit signs of adrenal autoimmunity.<sup>62</sup> Autoimmune oophoritis may occur as part of a type I or II autoimmune polyglandular syndrome (APS) associated with autoantibodies to multiple endocrine and other organs. Type I APS (also known as autoimmune polyendocrinopathy-candidiasis-ectodermal dystrophy) presents in childhood, typically as hypoparathyroidism (89%) or mucocutaneous candidiasis (75%), and often is accompanied by adrenal insufficiency (60–80%) and POF (60%); the cause is a mutation in the AIRE (autoimmune regulator) gene, located on chromosome 21. Type II APS has an adult onset and is characterized by adrenal insufficiency (100%) and thyroid autoimmunity (70%) or type I diabetes (50%); 25% of women with the disorder have amenorrhea and 10% have POF.<sup>62</sup> POI also has been described in women with systemic lupus erythematosus and myasthenia gravis.

The mechanism that stimulates or causes ovarian autoimmunity is unknown, but might involve a virus or other cause of damage to ovarian tissue that renders it antigenic, or a basic failure in immune regulation resulting in a loss of tolerance to some component of ovarian tissue. The hallmark of autoimmune oophoritis is a lymphocytic infiltrate surrounding secondary and antral follicles but not primordial follicles,<sup>182,183</sup> strongly suggesting that steroid hormone-producing cells in the theca contain the inciting antigen. Observations of normal inhibin B production in otherwise hypogonadal women with autoimmune oophoritis further suggest that the theca is selectively targeted and that granulosa cells are spared.<sup>184</sup> Almost all women with documented autoimmune oophoritis have circulating antibodies directed against steroidogenic enzymes such as 21-hydroxylase, 17 $\alpha$ -hydroxylase, and side-chain cleavage.<sup>63,182</sup> The diagnosis of autoimmune ovarian failure therefore hinges on the demonstration of autoantibodies against steroidogenic cells. **A positive test for adrenal or 21-hydroxylase antibodies is sufficient to establish a diagnosis of autoimmune ovarian failure.** A commercially available serum antiovarian antibody test had a poor predictive value and an unacceptably high false-positive rate.<sup>185</sup> **Ovarian biopsy solely for diagnosis of autoimmune ovarian failure is unnecessary and is not recommended.** Whereas antibodies against membrane-bound receptors may cause diseases such as myasthenia gravis, the failure to detect antibodies against the FSH receptor in women with POF suggests they rarely, if ever, are the cause.<sup>186</sup> Women with autoimmune ovarian failure may develop large luteinized follicular cysts, possibly due to increased gonadotropin stimulation in response to impaired follicle development and function.<sup>184</sup>

**The strong association between autoimmune adrenal and ovarian failure justifies screening for antiadrenal antibodies in all women with POF, at the time of diagnosis.** The most sensitive and useful methods for their detection are indirect immunofluorescence assays using adrenal tissue as substrate and immunoprecipitation assays for antibodies against the 21-hydroxylase enzyme (CYP21). **Patients with positive antiadrenal antibodies should be further evaluated to exclude asymptomatic adrenal insufficiency, by measuring the morning (6:00–9:00 A.M.) serum cortisol level.** A value greater than 18 mg/dL effectively excludes clinical adrenal insufficiency; those with lower values require further evaluation with an ACTH stimulation test to determine whether ACTH reserve is sufficient to meet demand during times of stress. The test is performed by measuring the serum cortisol concentration before and 60 minutes after administering cosyntropin (synthetic ACTH 1–24; 0.25 mg) intramuscularly or intravenously; a stimulated cortisol concentration  $\geq 18$  mg/dL is a normal response. **Those with negative tests for adrenal antibodies should be followed and monitored with repeat testing at intervals, because POF may precede onset of adrenal insufficiency by up to several years and its autoimmune cause may not, at first, be recognized.**<sup>63</sup>

Other autoimmune disorders that may be identified in women with POI, such as autoimmune thyroiditis, rarely are associated with autoimmune oophoritis and therefore cannot be considered proof of autoimmune ovarian failure. **However, because the prevalence of thyroiditis is relatively high among women with POI (14–27%) and the presence of thyroid autoantibodies identifies patients at risk for developing autoimmune thyroid disease, screening for thyroid peroxidase and thyroglobulin antibodies is indicated when POI is suspected.** For patients screening positive for antithyroid antibodies, TSH levels should be monitored annually; for those testing negative, TSH surveillance can be less often (e.g., 5-year intervals). In the past, screening for other autoimmune endocrine disorders was recommended (serum calcium, phosphorus, fasting glucose, vitamin B<sub>12</sub>), but such screening has a very low yield in asymptomatic patients and can be safely reserved for those with clinical indications.<sup>64</sup>

## **Radiation Therapy**

The adverse effects of radiation on the ovary depend on the age of the patient, the dose of radiation, and the radiation field.<sup>187</sup> In young women, radiation therapy may result only in transient amenorrhea that ends after a period of 6–18 months, probably reflecting the interval required to reestablish the mechanisms that govern the initiation of follicular growth and the size of their follicular reserve. Transient suspension of normal ovarian cycling also has been observed in women who received radioactive iodine for the treatment of thyroid cancer.<sup>188</sup> However, some will suffer immediate and irreversible

ovarian failure, and even those who recover may later exhibit early ovarian aging and an early menopause. The ovaries of older women are more sensitive to the effects of radiation. Whereas doses greater than 6 Gy (gray units, 1 Gy = 100 rad) almost uniformly cause ovarian failure in women over age 40,<sup>189</sup> younger women have achieved successful pregnancies after having received far higher doses.

The radiosensitivity of human oocytes has been estimated at approximately 2 Gy, implying that approximately 50% of remaining oocytes will survive after such exposure.<sup>190</sup> Using the best available model for the rate of natural follicular depletion,<sup>191</sup> estimates for the mean and effective sterilizing doses of radiation (resulting in immediate and permanent ovarian failure in 50% and 97.5% of individuals, respectively) can be calculated. The mean age of subsequent ovarian failure also can be estimated for any given age and dose of radiation. Representative values derived from such calculations are shown in [Tables 10.2](#) and [10.3](#).<sup>192</sup>

## **TABLE 10.2 Patient Age and Radiation Dose are Both Relevant to the Magnitude of Gonadotoxic Insult Following Radiation Exposure**

Age at Treatment (y)	Sterilizing Dose (Gy)	
	Mean (50%)	Effective (97.5%)
0	18.8	20.3
10	17.0	18.4
20	15.0	16.5
30	12.0	14.3
40	8.0	11.3

**TABLE 10.3 Radiation Induced Ovarian Failure**

Age at Treatment (y)	Mean Predicted Age of Ovarian Failure (y)			
	3 Gy	6 Gy	9 Gy	12 Gy
0	35.1	22.6	13.7	7.9
10	36.7	26.5	19.7	15.3
20	39.0	31.4	26.4	22.8
30	42.2	37.0	33.2	30.1

When the radiation field excludes the pelvis, there is no significant risk for permanent ovarian failure.<sup>193,194</sup> Consequently, direct irradiation to the ovaries should be avoided whenever possible. Elective ovarian transposition (moving the ovaries out of the radiation field) can help to preserve gonadal function in patients receiving pelvic radiation without chemotherapy. It may be performed electively before radiation therapy begins or at the time of surgical staging or the primary cytoreductive surgery.<sup>187,195</sup> However, the success of ovarian transposition for preserving fertility after radiation therapy has varied widely, from 16% to 90%, due to differences in treatment regimens, exposure to scatter radiation, shielding, and adjuvant chemotherapy. The procedure also has potential complications, including chronic ovarian pain and cysts, which may require additional surgery. Subsequently, pregnancy also may be difficult to achieve spontaneously or even with IVF, unless the ovaries are moved back into the pelvis.<sup>196</sup> Other fertility preservation strategies that might be considered before radiation therapy include urgent IVF and embryo cryopreservation, oocyte cryopreservation, and ovarian tissue cryopreservation, as discussed in detail in [Chapter 29](#).

There is no evidence for an increased risk of birth defects in the offspring of women treated with radiation therapy, chemotherapy, or both.<sup>197</sup> However, the risk for pregnancy complications such as miscarriage, preterm labor, and low birth weight may be increased due to impaired uterine growth and blood flow.<sup>198,199,200</sup>



## **Chemotherapy**

Most chemotherapeutic drugs target actively dividing cells and therefore might not be expected to have significant adverse effects on oocytes; nonetheless, many do. In fact, the fixed supply of oocytes is extremely sensitive to cytotoxic drugs. **Chemotherapy causes depletion of the primordial follicular pool in a drug- and dose-dependent manner and is a relatively common cause of POI.**

The ovarian toxicity of common chemotherapeutic agents varies significantly.<sup>196,197</sup> Alkylating agents such as cyclophosphamide, which alters base pairs and causes DNA cross-links and breaks, can affect both resting and dividing cells. The risk for ovarian failure after chemotherapy increases with the age of the patient, presumably because the size of the residual follicular pool declines progressively with advancing age and the damage caused by treatment becomes proportionately greater. For example, a dose of cyclophosphamide that uniformly causes amenorrhea in women over age 40 does so in only about half of younger women.<sup>201</sup> However, individual women vary significantly in their sensitivity or susceptibility to gonadal damage from chemotherapeutic agents. The common use of more than a single drug further complicates efforts to predict the likelihood of ovarian failure resulting from treatment (Table 10.4).

### **TABLE 10.4 Chemotherapeutic Drugs Vary in Potential for Gonadotoxicity**

High Gonadal Toxicity	Moderate Gonadal Toxicity	Low Gonadal Toxicity
Cyclophosphamide	Cisplatin	Bleomycin
Chlorambucil	Adriamycin	Actinomycin D
Melphalan		Vincristine
Busulfan		Methotrexate
Nitrogen mustard		5-Fluorouracil
Procarbazine		Taxanes

It is important to note that a large majority of studies examining the effects of chemotherapeutic agents on ovarian function have used the incidence of amenorrhea, from as little as 6 months to as long as 5 years after completion of treatment, as the measure of impact. In recent years, gonadotoxic effects of chemotherapy and radiation therapy have utilized surrogate markers of “ovarian reserve” including serum levels of FSH, inhibin B, and AMH and ovarian antral follicle counts.<sup>202,203</sup> It is known that most women in the advanced stages of follicular depletion, due to aging or other causes, still menstruate even though the number and quality of their remaining oocytes and their fecundity are quite low.<sup>204</sup> Consequently, it seems certain that the amenorrhea rate associated with any given chemotherapeutic drug or combination grossly underestimates its true adverse impact on ovarian function and fertility. Indeed, observations derived from a few studies that have examined the effect of chemotherapy on markers of ovarian reserve (AMH in particular) suggest that chemotherapy induces accelerated ovarian aging and thereby increases the likelihood of POI well beyond the risk estimates based on observations of amenorrhea after the end of treatment.<sup>205,206,207</sup>

Long-acting GnRH agonists (GnRHa, e.g., leuprolide acetate) have been used widely to induce a hypogonadal state before chemotherapy in hopes to reduce or prevent the adverse effects of cytotoxic drugs on ovarian function and future fertility.

Protective effects of GnRHa-induced ovarian suppression against chemotherapy-induced gonadal damage were initially evident in experimental studies in animal models including nonhuman primates.<sup>208</sup> Subsequent studies including randomized controlled trials in women have corroborated that GnRH agonist pretreatment may offer some protection against chemotherapy-induced ovarian follicular depletion.<sup>209,210,211</sup> Overall, less than 10% of patients treated with a GnRH agonist before chemotherapy have developed irreversible POI, compared to 40–70% of those receiving similar treatment but no GnRH agonist. Some have suggested that, at the least, GnRH agonist pretreatment may widen or extend the “fertility window” by 7 years or more for patients who receive chemotherapy.<sup>209</sup> Several mechanisms have been proposed to explain the potential protective actions of GnRH agonists: (1) a decreased number of primordial follicles entering development (due to suppression of FSH), when they become more vulnerable to damage; (2) decreased ovarian perfusion induced by hypoestrogenism, resulting in lower exposure to chemotherapeutic agents; and (3) a direct effect on the ovary, independent of gonadotropins, such as up-regulation of an intraovarian antiapoptotic factor or protection of germline stem cells.<sup>209</sup> Moreover, advocates of GnRH agonist pretreatment have emphasized that it can decrease the risk of menorrhagia resulting from chemotherapy-induced thrombocytopenia and, at least in patients with hormone-sensitive breast cancers, also may improve survival rates.<sup>212</sup>

Questions concerning the value and even the safety of GnRH agonist chemoprophylaxis have stimulated an active and ongoing debate. Despite the accruing evidence supportive of clinical benefit, many have challenged the biologic plausibility of the proposed protective mechanisms and raised concerns that the initial “flare” in gonadotropin secretion that follows GnRH agonist treatment may have effects opposite from those intended. Those who oppose GnRH agonist pretreatment argue that the return of menses after chemotherapy is an insensitive and unreliable measure of protection from drug-induced ovarian injury,<sup>213</sup> that the sustained decrease in serum AMH levels that follows chemotherapy indicates a loss of primordial and preantral follicles (the primary source of AMH),<sup>207</sup> and that GnRH agonist treatment cannot protect against damage from cytotoxic drugs because primordial and preantral follicles are not sensitive to gonadotropin stimulation.<sup>214</sup> Lacking benefit of prechemotherapy, ovarian suppression with GnRHa on ovarian function has also been evident in other studies, raising concerns regarding potential for unequivocal benefit.<sup>215</sup> The safety of GnRH agonists has also been questioned because many tumors of the breast and reproductive tract express GnRH receptors mediating actions that might reduce the efficacy of chemotherapy or promote an even greater loss of follicles.<sup>216,217,218,219</sup> Finally, treatment with a GnRH agonist can be expected to induce acute symptoms of estrogen deficiency, in addition to those that invariably result from chemotherapy, thereby adding to the

overall burden of treatment. Ultimately, more confident conclusions regarding the relative risks and benefits of GnRH agonist pretreatment must await the results of a number of ongoing clinical trials being conducted by the Southwest Oncology Group in the United States and by others in Germany, Italy, Spain, and the United Kingdom.

## **Galactosemia**

Galactosemia is an autosomal recessive disorder of galactose metabolism caused by a deficiency of the enzyme GALT and is another, albeit very rare, cause of POF.<sup>220</sup> Affected women have fewer primordial follicles, presumably due to the cumulative toxicity of galactose metabolites on germ cell migration and survival.<sup>221,222</sup> Diagnosis usually is made in the first few days of life after feeding with breast or cows' milk-based formulas begins, causing jaundice, vomiting, and failure to thrive.

## **Functional Ovarian Failure Resulting from Disorders of Follicular Development**

Whereas accelerated follicular depletion is the underlying mechanism for the most common causes of POI, a variety of rare genetic disorders causing impaired or abnormal follicular development may result in a functional ovarian failure. Examples include disorders of intraovarian regulation, steroidogenic enzyme defects, and abnormalities in gonadotropins and their receptors. In 1969, Jones and de Moraes-Ruehsen described three patients with amenorrhea and hypergonadotropic hypogonadism who also were resistant to high doses of exogenous gonadotropins, although their ovaries contained numerous follicles. They called the disorder "resistant ovary syndrome" or "Savage syndrome," after the name of their first patient.<sup>223</sup> It now seems likely that the resistant ovary syndrome results from intrinsic defects in follicular development.

Abnormalities in any of the many identified paracrine regulators of ovarian function may interfere with or prevent a normal response to gonadotropin stimulation. For example, mutations in the gene encoding bone morphogenetic protein-15 (BMP15), an oocyte-specific growth factor that stimulates folliculogenesis and granulosa cell proliferation (in the same family that includes activins and inhibins), have been identified in a small number of women with idiopathic POF. In functional assays, the mutant BMP15 was processed abnormally, associated with decreased granulosa cell growth, and antagonized the stimulation of granulosa cell proliferation by wild-type BMP15.<sup>224</sup> In a study of women with POF who underwent genetic screening, 7/166 (4%) having heterozygous mutations in BMP15 were detected, compared to none in control groups containing women who had a natural menopause or women randomly selected from the general population.<sup>225</sup> The blepharophimosis/ptosis/epicanthus

inversus syndrome (BPES) is another example. BPES is a rare autosomal dominant disease characterized by eyelid malformations and POF, caused by a variety of mutations in the gene encoding a forkhead box transcription factor (FOXL2) required for normal granulosa cell function.<sup>226</sup>

Rare steroidogenic enzyme defects that effectively block follicular development may result in hypergonadotropic hypogonadism due to functional ovarian failure. Mutations in the genes encoding the steroidogenic acute regulatory (StAR) enzyme (STAR), the 17 $\alpha$ -hydroxylase enzyme (CYP17A1), and the aromatase enzyme (CYP19A1) are examples. The StAR enzyme transports cholesterol from the outer to the inner mitochondrial membrane where the side-chain cleavage enzyme converts cholesterol to pregnenolone, the first and rate-limiting step in steroid biosynthesis; StAR mutations thus result in impaired synthesis of all adrenal and gonadal steroid hormones. Affected individuals present with congenital lipoid adrenal hyperplasia and exhibit severe adrenal insufficiency soon after birth or in early infancy; those who are recognized and treated early have absent pubertal development.<sup>227</sup> Females with 17 $\alpha$ -hydroxylase deficiency, involving the enzyme complex that converts 21-carbon progestogens to 19-carbon androgens, usually present around the expected time of puberty with primary amenorrhea and sexual infantilism. Elevated levels of progesterone (the hormone immediately proximal to the enzyme block) are alternatively converted to mineralocorticoids (deoxycorticosterone, corticosterone), resulting in hypertension and hypokalemia. Those having a partial or less severe 17 $\alpha$ -hydroxylase deficiency may exhibit varying degrees of sex steroid production and sexual development.<sup>228</sup> Rare females with aromatase deficiency, involving the enzyme that converts androgens to estrogens, classically present with ambiguous genitalia at birth, elevated androgen levels, and absent breast development at puberty. During pregnancy, fetal androgens cannot be aromatized to estrogen in the placenta, resulting in masculinization of both the fetus and mother. Aromatase mutations also can produce variable or nonclassic phenotypes characterized by varying degrees of breast development.<sup>229</sup>

Inactivating mutations in the  $\beta$  (beta)-subunit of LH or FSH can result in abnormal gonadotropin molecules having limited or no immunoreactivity or bioactivity. Affected individuals are hypogonadal and have a high level of one (the normal) gonadotropin, but a basal or undetectable level of the other.<sup>230,231</sup> Inactivating mutations in the FSH or LH receptor may result in a failure of gonadotropin binding or signal transduction and thus again in hypergonadotropic hypogonadism due to a failure of follicular development.<sup>232</sup> One specific point mutation in the FSH receptor has a relatively high gene frequency in the Finnish population (0.96%).<sup>233,234</sup> A search for the same mutation among women with POF in the United States, Brazil, Switzerland, Denmark, Japan, and Singapore

found only a single carrier,<sup>235,236,237,238</sup> but other inactivating mutations have been identified.<sup>239,240</sup> A few women with similar mutations in the LH receptor have been described, presenting with amenorrhea, enlarged cystic ovaries, and a high serum LH but normal FSH concentration.<sup>241,242</sup>

## Management of Premature Ovarian Insufficiency

**It is important to emphasize that effective management of POI requires careful counseling and emotional support, as well as specific evaluation and medical treatment.** Young women with POI understandably are not prepared for the diagnosis, and many are dissatisfied with the manner in which they were informed.<sup>243</sup> Affected women need, and deserve, sufficient time for thorough education and for planning their longer-term management.

Attention should focus first on excluding those causes of POI having important potential health consequences for the patient or other members of her family. Those with chromosomal translocations or deletions or fragile X premutations should receive appropriate genetic counseling, and those with autoimmune disease will require careful monitoring over time to ensure that emerging and potentially serious health problems are promptly recognized and treated.

### Hormone Therapy

The short-term as well as longer-term management of women with POI centers on their hypogonadism and its sequelae. In the absence of exogenous estrogen treatment, women with POI are at a real risk for developing skeletal fragility due to low bone mass.<sup>244,245,246</sup> In the absence of hormone therapy, hypoestrogenism of POI is similarly implicated in predisposing this population to early coronary heart disease.<sup>247,248,249,250,251</sup> Inevitably, they also will develop symptoms of estrogen deficiency such as vasomotor flushes and genitourinary atrophy that can be debilitating. Therefore, unless there is a specific contraindication to its use, timely initiation of exogenous estrogen-based hormone therapy is of pivotal importance in the management of women with POI. Other strategies for protecting bone and heart health also deserve discussion, including regular exercise, diet, adequate calcium and vitamin D intake, stress reduction, and the avoidance of smoking.

Estrogen treatment in women with POI can take several forms. An increasing number of estrogen formulations are available for oral, transdermal (patch, gel, spray), and vaginal (creams, pessaries, tablets, rings) use. Physiologic levels of estrogen and symptom relief can be achieved in the majority using oral (e.g., micronized estradiol 1–2 mg daily or conjugated equine estrogens 0.625–1.25 mg daily) or transdermal

estrogen regimens (0.1 mg/24 hours).<sup>252</sup> Attention to concepts of hormonal formulation, dose, and route and hormonal regimen merits attention given that estrogen requirements to achieve symptom benefit in young women with POI may be higher when compared to older menopausal women.<sup>253,254,255</sup> Because most women with POF have an intact uterus, cyclic or continuous treatment with a progestogen is essential to prevent endometrial hyperplasia and neoplasia that can result from treatment with estrogen alone.<sup>256</sup> Cyclic treatment with a progestogen (e.g., micronized progesterone 200 mg daily or MPA 10 mg daily for 12–14 days each month) is preferable for those still hoping to conceive. Oral contraceptives also may be used to achieve symptomatic relief. However, the menopausal estrogen formulations are suggested to be superior to the synthetic ethinyl estradiol containing contraceptive formulations in conferring skeletal benefit.<sup>257</sup> Contraceptive hormonal regimens may thus be reserved for those who want to prevent even the possibility of random ovulation and pregnancy. **It is important to emphasize to young women with POF that they are distinctly different from older postmenopausal women and that the balance between the risks and benefits of hormone therapy for them also differs from that in postmenopausal women.** Because they are significantly younger, their baseline risks for cardiovascular disease and breast cancer are much lower than those for older postmenopausal women. In women with POI, timely initiation and use of estrogen therapy may actually reduce the risk of coronary heart disease and of all-cause mortality, whereas without estrogen therapy, their risk for later coronary heart disease is increased.<sup>248,249,250,251,255</sup> Estrogen-based hormone therapy should continue up to at least the age of 50, in much the same way as endogenous hormone production does in normal women.

Ovarian androgen levels (testosterone, androstenedione) may be somewhat lower in women with POI than in normal women of comparable age,<sup>258,259,260</sup> although in most they are maintained at least to the same extent as in normal postmenopausal women. Currently, there are no established criteria for diagnosis of androgen deficiency, and there is no approved or validated method for providing physiologic androgen treatment in women.<sup>255,261</sup> Moreover, exogenous androgen treatment may cause acne and hirsutism and, when administered orally, dyslipidemia. The longer-term clinical consequences of reduced androgen levels, if any, have not been studied, and the safety of long-term androgen treatment has not been established. Consequently, androgen treatment cannot be recommended for women with POF.

**Fertility** Although the likelihood of achieving pregnancy after diagnosis is only about 5–10%, some women with POF do conceive and approximately 80% of their pregnancies end in a healthy live birth.<sup>162</sup> **However, there is no evidence that any form of treatment other than donor egg IVF can increase the chance for pregnancy.**

Intermittent or episodic ovulation is by no means rare in women with POI. Serial blood sampling and transvaginal ultrasonography can demonstrate residual and even developing follicles, but disordered patterns of folliculogenesis frequently are observed and premature luteinization, possibly a consequence of elevated LH levels, is common.<sup>262</sup> Evidence indicates that physiologic exogenous estrogen therapy allows, but does not improve, follicular development or ovulation.<sup>263</sup> Although ovulation induction with exogenous gonadotropins often has been attempted, women with established hypergonadotropic hypogonadism are, for obvious reasons, poor candidates. Attempts to improve ovulation rates achieved with gonadotropin therapy by pretreatment with estrogen or a GnRH agonist have met with some limited success,<sup>263,264,265,266</sup> but pregnancy and live birth rates remain extremely low. Recent decades have witnessed increasing utilization of oocyte and embryo donation strategies for family building by a diverse group of populations including women with POI, who are excellent candidates for IVF using donor oocytes.<sup>267</sup> Attempts at harnessing the therapeutic potential of ovarian stem cells and at in vitro activation of residual gametes within POI ovaries are emerging frontiers in the field of reproductive medicine.<sup>268,269,270</sup> It has long been known that unlike naturally menopausal women, residual but arrested ovarian follicles exist in ovaries of women with POI. Recent data offer tantalizing hope for harnessing the procreative potential of these residual oocytes in POI ovaries through a sequence of steps that include surgical collection of ovarian tissue followed by in vitro activation of the AKT pathway that allows activation of the few dormant follicles that are present within the ovarian cortex; the activated ovarian tissue is then retransplanted followed by ovarian stimulation and IVF.<sup>270</sup> Refining of the methodology and establishment of safety are needed before this promising technologic advancement can be adopted in routine clinical care of POI patients.

## **Psychological and Emotional Support**

Profound grief and a sense of loss for the children they hoped for and expected are common in women after diagnosis of POF; validating those emotions can be both therapeutic and reassuring. It also is important to emphasize that the diagnosis of POF does not imply or predict premature aging in any other way, something that many women understandably may fear. Women with POF also are at risk for developing related depression and anxiety disorders.<sup>243,271</sup> Consequently, referral to a support group ([www.pofsupport.org](http://www.pofsupport.org)) and to a therapist having expertise in counseling women and couples with reproductive failure can be very helpful.



# Disorders of the Anterior Pituitary

A variety of disorders involving the anterior pituitary may be a cause of amenorrhea. Pituitary tumors are the most common by far and the majority of these are benign adenomas; in a large transsphenoidal surgical series, 91% of sellar and parasellar masses were pituitary adenomas.<sup>272</sup> Malignant pituitary tumors are almost never encountered. Other tumors that may arise in the sellar region include craniopharyngiomas, meningiomas, gliomas, metastatic tumors, and chordomas. Not all sellar masses are neoplastic<sup>273</sup>; cysts, tuberculosis, sarcoidosis, and fat deposits that compress the pituitary have been reported. Nearby lesions, such as internal carotid artery aneurysms, by compressive effects on the adjoining pituitary gland and the resident endocrine cells, and/or the pituitary stalk, can interfere with the delivery of hypothalamic releasing or inhibiting factors; the net effect is of functional disruption of the pituitary hormonal axis as a mechanism for amenorrhea.

Other pituitary causes of hypogonadotropic hypogonadism include damage from surgery or radiation, ischemia and infarction (e.g., Sheehan syndrome), and infiltrative diseases such as lymphocytic hypophysitis and hemochromatosis.

## Pituitary Adenomas

Pituitary adenomas are true neoplasms that are almost always benign. The large majority are monoclonal, suggesting that somatic cell mutations precede clonal expansion and play an important role in tumorigenesis.<sup>274,275</sup> Specific genetic mutations are known to be involved in the development of some pituitary tumors. Autosomal dominant inactivating mutations in the MEN1 gene (encoding menin, a putative tumor suppressor) predispose to the development of parathyroid, pituitary, and enteropancreatic adenomas (insulinomas, gastrinomas, carcinoid tumors) in patients with one of the multiple endocrine neoplasia (MEN) syndromes (type 1).<sup>276</sup> Activating mutations in the GNAS1 gene (encoding the stimulatory G-protein alpha subunit involved in the signal transduction pathway that links receptor-ligand interactions with activation of adenylyl cyclase) are identified in approximately 40% of GH secreting somatotroph adenomas.<sup>277</sup> The pituitary tumor transforming gene (PTTG1) is overexpressed in most all pituitary adenomas and, to an even greater degree, in those that extend outside of the sella.<sup>278</sup>

Pituitary adenomas are classified by cell type and size and may be functional (hormone-secreting) or nonfunctional. The large majority of pituitary adenomas are either functional prolactin-secreting lactotroph adenomas or nonfunctional adenomas, most of which derive from the gonadotrophs. Functional thyrotroph adenomas (secreting TSH and causing hyperthyroidism), somatotroph adenomas (secreting GH and causing

acromegaly), and corticotroph adenomas (secreting ACTH and causing Cushing disease) are rare, particularly in women presenting with amenorrhea. If large enough, even the nonfunctioning adenomas can have functional consequences, by compressing the pituitary stalk and interfering with the delivery of hypothalamic releasing or inhibiting factors or by compressing the surrounding cells. Tumors less than 10 mm in size are called microadenomas and those 10 mm or larger are called macroadenomas. Pituitary adenomas may be discovered during evaluation for neurologic symptoms or symptoms attributable to hormone imbalance (e.g., prolactinomas are often diagnosed during workup for menstrual irregularities including amenorrhea) or when the head is imaged for other reasons (such as following head trauma). MRI (with gadolinium contrast) is the best radiologic method for imaging the pituitary gland and surrounding region and may reveal tumor extending outside of the sella, into the cavernous sinuses or sphenoid sinus, or causing elevation of the optic chiasm.

The most common neurologic symptom associated with pituitary tumors, in particular macroadenomas, is visual impairment. The classical complaint is of bitemporal hemianopsia (tunnel vision), caused by upward pressure on the optic chiasm at its center (affecting those portions of the optic nerves correlating with the nasal retinas and the temporal visual fields); however, one or both eyes may be affected and to varying degrees. Decreased visual acuity develops with more severe compression of the chiasm, and diplopia (blurred vision) results from lateral extension and compression of the oculomotor nerve. The onset of visual symptoms is so gradual they often go unrecognized for months or years. Other neurologic symptoms include nonspecific headaches (from expansion of the sella), cerebrospinal fluid rhinorrhea (from inferior extension of the tumor), and pituitary apoplexy (caused by sudden hemorrhage into the adenoma).

The endocrine consequences of pituitary adenomas depend on whether they are functional or nonfunctional and on their size. Functional microadenomas and macroadenomas secrete excessive amounts of hormone, according to their specific cell type, and cause symptoms that result from overstimulation of the target organ or tissues, as discussed below. Functional and nonfunctional macroadenomas also may cause pituitary hormone deficiencies, due to their mass effects on the pituitary stalk and surrounding cells. Whereas gonadotropin deficiency results in symptoms of hypogonadism such as amenorrhea and vaginal atrophy, the symptoms of TSH deficiency are those of hypothyroidism and include fatigue, lethargy, cold intolerance, decreased appetite, constipation, dry skin, bradycardia, and anemia. Symptoms of GH deficiency vary based on timing of occurrence; GH deficiency in children causes short stature, whereas in adults, GH deficiency is often subtle, often with tiredness and an overall reduced sense of well-being as the only manifestations. Less manifest features of GH deficiency in adults include decreased muscle mass and increased fat mass,<sup>279,280</sup>

decreased bone mineral density,<sup>281</sup> and an increased risk for cardiovascular disease.<sup>282,283</sup> Prolactin deficiency has no known symptoms other than failure to initiate and establish lactation after delivery. The symptoms of ACTH deficiency are those of cortisol deficiency and include postural hypotension and tachycardia, fatigue, anorexia, weight loss, hypoglycemia, and eosinophilia. Whereas primary adrenal insufficiency (due to abnormalities involving the adrenal glands) also results in salt wasting, volume contraction, and hyperkalemia resulting from aldosterone deficiency and hyperpigmentation due to the compensatory increase in pituitary ACTH secretion, secondary adrenal insufficiency (as occurs due to defective function of the pituitary adrenocorticotrophs with resulting ACTH deficiency) does not. Both primary and secondary adrenal insufficiencies can cause hyponatremia due to inappropriate secretion of antidiuretic hormone (ADH) (vasopressin), which results from cortisol deficiency. **Moderate deficiencies of TSH, GH, and ACTH often cause few or no recognizable symptoms and easily can go unrecognized if not suspected and specifically excluded through targeted testing.**

## **Pituitary Function Tests**

In women with macroadenomas, pituitary function tests are indicated to exclude other pituitary hormone deficiencies that may have important health implications. Although the required additional evaluation generally is not difficult to perform or interpret and only a few with abnormal results may require more complicated dynamic tests, the generalist reasonably may want to consult with or refer such patients to a reproductive or medical endocrinologist more familiar with the indicated tests. **The recommended endocrine evaluation of women with amenorrhea includes the measurement of serum hCG (to rule out pregnancy as a cause for amenorrhea), TSH (to assess for hypothyroidism or hyperthyroidism as a mechanism for amenorrhea), prolactin (to assess for hyperprolactinemia), and both FSH and estradiol (elevated FSH and low estradiol levels in the setting of amenorrhea are consistent with a picture of POI). Women with pituitary macroadenomas require additional evaluation, including a serum free T4 (reflecting adequacy of thyroid function), IGF-1 (reflecting GH axis), and morning cortisol level (reflecting adequacy of adrenal cortical function, to be drawn between 06:00 and 9:00 A.M.).**

When the serum TSH level is low or normal, a low serum free T4 demonstrates secondary hypothyroidism. **It is important to understand that measurement of serum TSH alone is not sufficient in patients who may have hypothalamic or pituitary disease.** A normal TSH level excludes hypothyroidism only when there is every reason to believe that the hypothalamo-pituitary-thyroid axis is intact and functioning normally. In women with a sellar mass and hypogonadotropic hypogonadism (low FSH and low

estradiol), indicating a dysfunctional HPO axis, normal function of the thyroid axis cannot be assumed. High levels of both TSH and free T4 suggest a rare functional thyrotroph adenoma (causing hyperthyroidism).<sup>284</sup>

Screening for GH deficiency or excess is best accomplished by measuring the serum IGF-1 level, because the basal serum GH concentration is not reliable in adults. IGF-1 is produced in the liver, in response to GH stimulation, and a concentration below the age-specific normal lower limit has greater than 95% specificity for diagnosis of GH deficiency.<sup>285</sup> Provocative tests of GH secretion such as the insulin-induced hypoglycemia test or the combined administration of arginine and GH-releasing hormone are more sensitive,<sup>285</sup> but seldom are necessary. An elevated serum IGF-1 concentration suggests a GH-secreting somatotroph adenoma (causing acromegaly).<sup>286</sup>

A very low morning cortisol level (<3–5 mg/dL) indicates adrenal insufficiency and implies ACTH deficiency; a value  $\geq$ 15–18 mg/dL demonstrates normal cortisol secretion. Intermediate values require additional evaluation to determine whether ACTH reserve is sufficient to meet demand during times of stress. ACTH reserve can be evaluated most easily by performing an ACTH stimulation test, based on the premise that chronic ACTH deficiency results in adrenal cortical atrophy and the inability to increase cortisol secretion normally in response to an acute ACTH stimulus. The test is performed by measuring the serum cortisol concentration before and 60 minutes after administering cosyntropin (synthetic ACTH 1–24; 0.25 mg) intramuscularly or intravenously; a stimulated cortisol concentration  $\geq$ 15–18 mg/dL is a normal response. A grossly elevated basal serum cortisol concentration may suggest the possibility of hypercortisolism (Cushing syndrome), which, if resulting from an ACTH-secreting corticotroph adenoma, is then identified as Cushing disease. However, additional more specific evaluation is required for diagnosis of Cushing syndrome and to determine its cause,<sup>287</sup> as described below (see Corticotroph Adenomas).

Testing for prolactin deficiency is unnecessary because the only clinical consequence relates to nursing and there is no effective treatment for failed lactation due to prolactin deficiency. Whereas hyperprolactinemia obviously suggests a functional lactotroph adenoma, prolactin levels also are commonly elevated in women with nonfunctional pituitary adenomas and other sellar masses.

## Gonadotroph Adenomas

**The large majority of gonadotroph adenomas are nonfunctional, do not secrete significant amounts of FSH or LH, and do not cause clinical symptoms; 80–90% of all nonfunctional pituitary adenomas derive from gonadotrophs.** Moreover, even moderately elevated gonadotropin levels do not cause specific symptoms. Consequently, gonadotroph adenomas most often present with symptoms resulting from their sheer size,

such as headaches and visual disturbances, rather than with amenorrhea.<sup>288,289,290</sup> Rare FSH-secreting adenomas however may cause spontaneous ovarian hyperstimulation, resulting in amenorrhea, multiple large ovarian cysts, and high serum FSH and estradiol levels<sup>291,292,293</sup>; in prepubertal girls, they may cause breast development and vaginal bleeding.<sup>294</sup> However, most patients with gonadotroph adenomas have normal or low serum gonadotropin concentrations because these tumors are nonfunctional and disrupt menstrual function only indirectly, via compression of the pituitary stalk or the surrounding cells. They may inhibit gonadotropin secretion by interrupting the delivery of hypothalamic GnRH or by compressing normal gonadotrophs. Alternatively, they may cause hyperprolactinemia by interfering with the inhibitory actions of dopamine on the lactotrophs, resulting in a secondary suppression of hypothalamic GnRH secretion mediated via excess prolactin, with consequent amenorrhea. Although such “null cell” tumors rarely produce clinically significant amounts of gonadotropins, they do exhibit gonadotropin production in vitro or gene expression at the mRNA level.<sup>295,296</sup> Gonadotroph adenomas also may secrete large amounts of the  $\alpha$  (alpha)-subunit common to all of the pituitary glycoprotein hormones (having no intrinsic biologic activity and therefore causing no symptoms).

A nonfunctioning gonadotroph adenoma can be the cause for persistent mild elevations in prolactin levels and should be considered in patients having a serum prolactin level under 100 ng/mL with no signs of hyperthyroidism, acromegaly, or Cushing syndrome. In the presence of low or normal gonadotropin levels, an elevated level of free  $\alpha$ -subunit also suggests a nonfunctioning gonadotroph adenoma.<sup>295</sup> In rare cases of functioning gonadotroph adenomas, the serum FSH may be elevated when the LH level is low. In premenopausal women, persistent elevated levels of both FSH and estradiol, associated with multicystic ovaries and endometrial hyperplasia, strongly suggest a functional FSH-secreting gonadotroph adenoma causing ovarian hyperstimulation.<sup>291,297,298,299</sup> Treatment with a GnRH agonist fails to down-regulate gonadotropin secretion in women with such tumors and may even cause or exacerbate ovarian hyperstimulation.<sup>292</sup>

In patients with neurologic symptoms or clinically bothersome picture resulting from excess gonadotropin secretion (as in cases of multicystic ovaries with symptoms of ovarian hyperstimulation), transsphenoidal surgical resection of a gonadotroph or other nonfunctioning adenoma can provide rapid relief. If surgery succeeds in removing the adenoma but not the adjoining normal pituitary, gonadotropin secretion and ovarian function should return to normal. However, surgery also may result in damage to the normal pituitary tissue, thereby causing additional pituitary hormone deficiencies or a more global panhypopituitarism.<sup>300</sup> Serious complications of transsphenoidal surgery are uncommon, occurring in less than 5% of patients, but include worsening vision,

hemorrhage, and cerebrospinal fluid rhinorrhea leading to meningitis. Variations in the secretion of ADH, causing diabetes insipidus or the opposite problem, the syndrome of inappropriate antidiuretic hormone (SIADH), are more common but are usually only transient. Conventional or stereotactic radiation therapy is useful when postoperative imaging reveals significant residual tumor or progressive regrowth following surgery. In patients having no neurologic symptoms or clinically important gonadotropin secretion, nonfunctioning microadenomas and macroadenomas can be monitored carefully by serial imaging at annual intervals (beginning 6 months after diagnosis for macroadenomas) to detect progressive growth and with decreasing frequency in the absence of any change. Any associated pituitary hormone deficiencies should be replaced.

## **Thyrotroph Adenomas**

Functional thyrotroph adenomas are a rare cause of hyperthyroidism, accounting for less than 1% of all functional pituitary tumors. Most patients present with the typical signs and symptoms of hyperthyroidism; other clinical manifestations can include a diffuse goiter, visual impairment, menstrual disturbances, and even galactorrhea. Because the TSH secreted by thyrotroph adenomas can vary greatly in biologic activity and in immunoactivity, serum TSH concentrations also can vary widely, ranging from normal (but still inappropriately high in the presence of hyperthyroidism) to markedly elevated.<sup>301</sup> The majority of patients with functional thyrotroph adenomas also have elevated serum concentrations of the free  $\alpha$ -glycoprotein hormone subunit.

Transsphenoidal surgery is the standard treatment for patients with functional thyrotroph adenomas, but has yielded mixed results, primarily because most such tumors are macroadenomas and surgery often is not curative. For those with persistent tumor, treatment with the somatostatin analog octreotide is effective in most,<sup>301</sup> so much so that 6–12 months of preoperative treatment with octreotide may be considered for patients with large functioning thyrotroph adenomas. Antithyroid therapy is not indicated, because the decrease in thyroid hormone may be expected to further stimulate TSH secretion and accelerate tumor growth.

## **Somatotroph Adenomas**

Functional GH-secreting somatotroph adenomas are the cause of more than 95% of cases of acromegaly.<sup>286</sup> GH stimulates excess hepatic IGF-1 secretion, which, in turn, causes most of the clinical features of the disorder. The characteristic signs of acromegaly are an enlarged jaw; enlarged and swollen hands and feet, resulting in increasing shoe and ring size; thickening and enlargement of the tongue; and joint symptoms relating to hypertrophic arthropathy. However, the onset and progression of

acromegaly are extremely slow, and it typically evolves over a period of several years. At the time of diagnosis, most patients have macroadenomas, many with extension outside of the sella.

Serum IGF-1 levels do not vary with meals, the time of day, or exercise, but do vary with age, being highest during puberty and decreasing gradually thereafter. The IGF-1 level therefore must be interpreted according to established age-specific norms. Most patients with acromegaly also have elevated serum GH levels, but concentrations fluctuate widely in response to a variety of stimuli, including fasting, exercise, stress, and sleep; levels also may be elevated in those with poorly controlled diabetes, liver disease, and malnutrition. Because random serum GH measurements can be difficult to interpret confidently, the most specific test for diagnosis of acromegaly is an oral glucose tolerance test. In normal individuals, GH levels fall to very low levels within 2 hours after ingesting 75 g of glucose ( $<0.3$  ng/mL when measured with a modern highly sensitive immunoradiometric or immunochemiluminescent assay); a GH level greater than 0.3 ng/mL is abnormally high.<sup>302</sup>

Transsphenoidal surgery is the treatment of choice for patients with somatotroph adenomas. The outcomes achieved with surgery generally are very good; in 80–90% of patients with microadenomas, GH secretion declines to normal and other pituitary functions are preserved; results are more variable in those with macroadenomas.<sup>303,304</sup> Clinical symptoms rapidly improve after successful surgery. Effective medical treatments are available for treatment of persistent or recurrent tumor and symptoms, including somatostatin analogs (e.g., octreotide, lanreotide), which inhibit GH secretion, and GH receptor antagonists (e.g., pegvisomant), which lower IGF-1 concentrations.

## **Corticotroph Adenomas**

Functional ACTH-secreting corticotroph adenomas are the specific cause of Cushing disease and one cause of the more general disorder, Cushing syndrome, which results from an excess of circulating glucocorticoids. The most common cause of Cushing syndrome is the ingestion of prescribed glucocorticoids (e.g., prednisone), although oral, injected, topical, and inhaled glucocorticoids also may cause the disorder.<sup>305,306,307</sup> Other causes include cortisol-secreting adrenal adenomas and carcinomas and ectopic production of ACTH or corticotropin-releasing hormone (CRH) by bronchial carcinoids and other rare tumors.

The classical clinical manifestations of Cushing disease result primarily from hypercortisolism, caused by increased ACTH stimulation of the adrenals, and vary with the duration and extent of excess cortisol secretion. The most common features are progressive central obesity, features resulting from excess fat accumulation in the buccal

(“moon face”) and nuchal (“buffalo hump”) fat pads, those caused by atrophy of the skin and subcutaneous tissue (such as easy bruising and purple striae on the abdomen and flanks), and hyperpigmentation (caused by excess ACTH), which is most noticeable in areas exposed to light (the face, neck, and back of the hands) or at skin sites exposed to chronic mild trauma, friction, or pressure (the elbows, knees, knuckles, and shoulders); hyperpigmentation of Cushing disease may additionally involve mucosal surfaces such as the inner lip. Menstrual abnormalities are common, affecting up to 80% of women, with one-third developing amenorrhea.<sup>308</sup> Other common signs and symptoms result from mild androgen excess (hirsutism, acne) and the effects of excess cortisol on skeletal muscle (proximal muscle wasting and weakness), bone (osteoporosis), and glucose metabolism (insulin resistance, glucose intolerance, diabetes). Functional corticotroph adenomas are usually quite small and may be difficult to image.

The diagnostic evaluation for suspected Cushing syndrome begins by measuring 24-hour urinary free cortisol excretion (twice) and the late-night (11:00 P.M.) salivary cortisol level (twice) or by performing an overnight or low-dose dexamethasone suppression test; the three screening tests have similar diagnostic accuracy.<sup>309</sup> Urinary creatinine excretion should be measured in the same specimen to judge compliance with instructions because a reliable 24-hour urine collection can be difficult to obtain. The urinary cortisol excretion and the late-night salivary cortisol level are interpreted by comparison to established normal laboratory ranges. The overnight dexamethasone suppression test is performed by administering 1.0 mg of dexamethasone by mouth between 11:00 P.M. and midnight and measuring the serum cortisol at 8:00 A.M. the following morning; a value less than 1.8 mg/dL is a normal result.<sup>287</sup> The low-dose dexamethasone suppression test is performed by administering 0.5 mg of dexamethasone by mouth every 6 hours over 2 days for a total of 8 doses (e.g., 8:00 A.M., 2 P.M., 8:00 P.M., and 2:00 A.M.) and measuring serum cortisol 2 or 6 hours after the last dose; as with the overnight test, a value less than 1.8 mg/dL is a normal result.<sup>287</sup> If the first screening test is abnormal, a second, different, test should be performed. Those with concordant abnormal results require additional evaluation to determine the cause of Cushing syndrome, as discussed in detail in [Chapter 13](#). Those with discordant results also merit further testing. Those with normal results require no further evaluation, except when the clinical suspicion is high, based on the clinical presentation.

The treatment of choice for Cushing disease is transsphenoidal surgery; among experienced surgeons, the permanent cure rate is approximately 70%. Radiation therapy is an option for those not cured by surgery and is effective in approximately 45% of adult patients. Bilateral total adrenalectomy, requiring lifelong daily glucocorticoid and mineralocorticoid treatment, is the final and definitive cure.<sup>310</sup>

## **Lactotroph Adenomas (Prolactinomas)**



Functional lactotroph adenomas are common, accounting for approximately 40% of all clinically recognized pituitary adenomas. Most arise from clonal expansion of a single cell, presumably due to a somatic mutation. They also may occur as part of the MEN1 syndrome, a possibility that can be effectively excluded by measuring the serum calcium level since primary hyperparathyroidism (hypercalcemia associated with an inappropriately high parathyroid hormone level) is the most common clinical manifestation of the disorder. Approximately 10% of adenomas that secrete prolactin also secrete GH, leading some to recommend measuring the serum IGF-1 concentration, even in women with microadenomas.<sup>311</sup> In women with lactotroph adenomas, serum prolactin concentrations generally correlate with the size of the adenoma. Microadenomas usually are associated with serum prolactin concentrations less than 200 ng/mL and macroadenomas with higher levels, but exceptions in either case are not uncommon. In some women with large lactotroph macroadenomas, prolactin levels are only modestly elevated because the tumor is largely cystic, or due to an assay artifact that may occur when a test sample contains a massive excess of antigen that saturates both the capture and signal antibodies, preventing them from forming a “sandwich” in immunoradiometric and chemiluminescent assays (known as the “hook effect”).<sup>312</sup>

Hyperprolactinemia commonly results in menstrual disturbances and is the cause of secondary amenorrhea in up to 30% of women.<sup>313</sup> The mechanism relates to inhibition of hypothalamic GnRH secretion, which, in turn, results in decreased pituitary gonadotropin secretion and in anovulation or a more severe hypogonadotropic hypogonadism, depending on the level of hyperprolactinemia and the extent to which gonadotropin secretion is suppressed. Chronic hypogonadism in a reproductive-age woman may result in progressive bone loss that improves after prolactin levels get normalized and functioning of the HPO axis is restored, but bone mineral density does not always return to normal.<sup>314</sup> Hyperprolactinemia also may result in galactorrhea, but most hyperprolactinemic women do not have galactorrhea, primarily because their estrogen levels are abnormally low. Although prolactinomas are much more common in adults, they can cause growth failure and primary amenorrhea in children.<sup>315</sup> Postmenopausal women with prolactinomas do not exhibit the classical symptoms and often are recognized only when a large tumor causes neurologic symptoms.

## Medical Treatment

Dopamine agonists are the first-line treatment of choice for women with functional prolactin-secreting lactotroph adenomas of all sizes because they effectively lower prolactin levels and decrease the size of more than 90% of such tumors.<sup>316</sup> Bromocriptine and cabergoline both are highly effective. Cabergoline, a selective dopamine receptor type 2 agonist, has fewer side effects, has greater potency, and is

also more effective than bromocriptine in restoring normal prolactin levels in women with lactotroph adenomas.<sup>26,27</sup> Consequently, most consider it the better choice. However, even at relatively low doses, long-term use of cabergoline may increase the risk of hypertrophic valvular heart disease.<sup>30,31</sup> Bromocriptine poses no such risk and some therefore consider it a somewhat safer choice, reserving cabergoline for those patients who prove intolerant or resistant to bromocriptine. To minimize side effects, treatment with either drug should begin with a low dose (e.g., bromocriptine 1.25 mg at bedtime; cabergoline 0.25 mg twice weekly) and increase gradually, guided by serial prolactin levels obtained at approximately monthly intervals. In general, the higher the prolactin level, the greater the dose of dopamine agonist required to restore normal prolactin levels. In women with large macroadenomas and very high prolactin levels, doses of bromocriptine up to 5 mg twice daily and of cabergoline up to 1.5 mg twice weekly may be required. Either drug also may be administered vaginally in women who cannot tolerate oral treatment.<sup>33,34</sup>

Prolactin levels typically decrease within 2–3 weeks after treatment begins and can be normalized in virtually all patients with microadenomas and in nearly all of those with macroadenomas.<sup>317</sup> In women with macroadenomas causing visual impairment, significant improvement can be observed within days after treatment begins and increases gradually over a period of months.<sup>318,319</sup> Significant shrinkage of adenomas may begin in as little as 6 weeks but can be assessed more confidently by repeating the MRI after 3–6 months of treatment. Longer durations of treatment often achieve further shrinkage in the size of the adenoma.<sup>317,320,321</sup> In women with macroadenomas, size generally decreases in parallel with the prolactin level. However, the overall response does not always correlate with the basal prolactin level, the absolute or relative decrease in concentrations, or even the normalization prolactin levels. **The failure of a tumor to shrink significantly in size despite a normalization of prolactin levels strongly suggests it is a nonfunctioning adenoma, rather than a functional lactotroph adenoma.** Menses, ovulation, and fertility typically return when normal prolactin levels are restored.<sup>26</sup> For women seeking pregnancy, the safety of both drugs is now established.<sup>35,36</sup> In those who cannot tolerate dopamine agonist treatment and therefore remain hyperprolactinemic and anovulatory, ovulation induction can be induced with exogenous gonadotropins.

In women with microadenomas, the dose of dopamine agonist often can be reduced after approximately 1 year of treatment, and a trial discontinuation can be attempted if prolactin levels have been normal for 2 years or more and MRI reveals no evidence of the adenoma. In those with macroadenomas, an MRI should be repeated after 6 and 12 months of treatment to determine the extent to which the adenoma has decreased in size. If the prolactin level has been normal for a year or more and the adenoma has decreased

significantly in size, the dose of treatment can be reduced gradually as long as the prolactin level remains normal.<sup>322</sup> As with microadenomas, a trial discontinuation of treatment can be attempted after prolactin levels have been normal for 2 years if MRI reveals no persistent tumor. Frequently, but not always, prolactin levels rise again after discontinuation of treatment. In a large retrospective study, recurrent hyperprolactinemia was observed in 75% of patients with microadenomas and in 84% of those with macroadenomas treated with bromocriptine.<sup>323</sup> However, in a prospective study involving 105 patients with microadenomas and 70 with macroadenomas, treatment was discontinued when prolactin levels were normal and MRI demonstrated no residual tumor, or more than a 50% decrease in size with no cavernous sinus invasion and more than 5 mm separation from the optic chiasm; hyperprolactinemia returned in only 31% of patients with microadenomas and in 36% of those with macroadenomas and no tumor regrowth was observed in any patient after 2–5 years of observation.<sup>324</sup> The best candidates for discontinuation of treatment are those with normal serum prolactin levels and very little or no visible residual tumor on MRI.

A dopamine agonist is the best initial treatment for women with prolactin-secreting macroadenomas and is certainly a suitable choice, but not the only treatment option, for women with microadenomas. As in hyperprolactinemic women having no adenoma, treatment can be tailored to the patient's needs and goals. Treatment with a dopamine agonist is the clear choice for women ready to attempt pregnancy (for ovulation induction) and those with troublesome galactorrhea. Others may be treated with physiologic cyclic estrogen/progestin therapy or with combined hormonal contraception (orally or vaginally administered), according to their contraceptive needs; such treatments pose little or no risk for stimulating tumor growth.<sup>37,38</sup> However, it is prudent to monitor serum prolactin levels approximately every 6 months and to repeat the MRI 1 and 2 years after diagnosis to reassess the size of the adenoma.

## Surgical Treatment

In patients with lactotroph adenomas who cannot tolerate or prove resistant to dopamine agonist treatment, transsphenoidal surgery is an appropriate alternative. Surgery might also be considered for women with very large macroadenomas (e.g., >3 cm) who want to attempt pregnancy, even when their tumor responds to medical treatment. Although surgery offers the possibility of a permanent cure, it also has important limitations and potential consequences. Incomplete resection of the tumor and persistent hyperprolactinemia are unfortunately common, more so in patients with macroadenomas (up to 90%) than in those with microadenomas (approximately 30%), as might be expected, and depending upon the skill and experience of the neurosurgeon. Recurrent hyperprolactinemia and tumor also may be observed within 5 years after surgery.<sup>325,326</sup> In general, the higher the initial prolactin level, the lower the permanent cure rate. Not

surprisingly, better outcomes can be expected when the adenoma lies entirely within the sella, emphasizing the importance of preoperative medical treatment for patients with extrasellar lesions.<sup>327</sup> The best predictor of a long-term cure is the prolactin level on the day following surgery. In the largest series with long-term follow-up on more than 400 women, the recurrence rate was 26% when postoperative prolactin levels were 20 ng/mL or less.<sup>328</sup> The risks and potential consequences of transsphenoidal surgery otherwise are the same as for other types of pituitary adenomas (see Gonadotroph Adenomas, above). For those with persistent hyperprolactinemia and tumor, management options include dopamine agonist treatment and radiation therapy.

## Radiation Therapy

Radiation therapy can decrease the size of lactotroph adenomas, but prolactin levels and tumor size decrease only very slowly, over a period of several years.<sup>329,330</sup> Therefore, radiation therapy is used primarily in the management of women with large macroadenomas having significant residual tumor after surgery. Approximately half of patients treated with radiation slowly develop panhypopituitarism over the 10 years following treatment.<sup>331</sup> Consequently, patients treated with radiation must be followed carefully over time, alert to the signs and symptoms of pituitary hormone deficiencies.

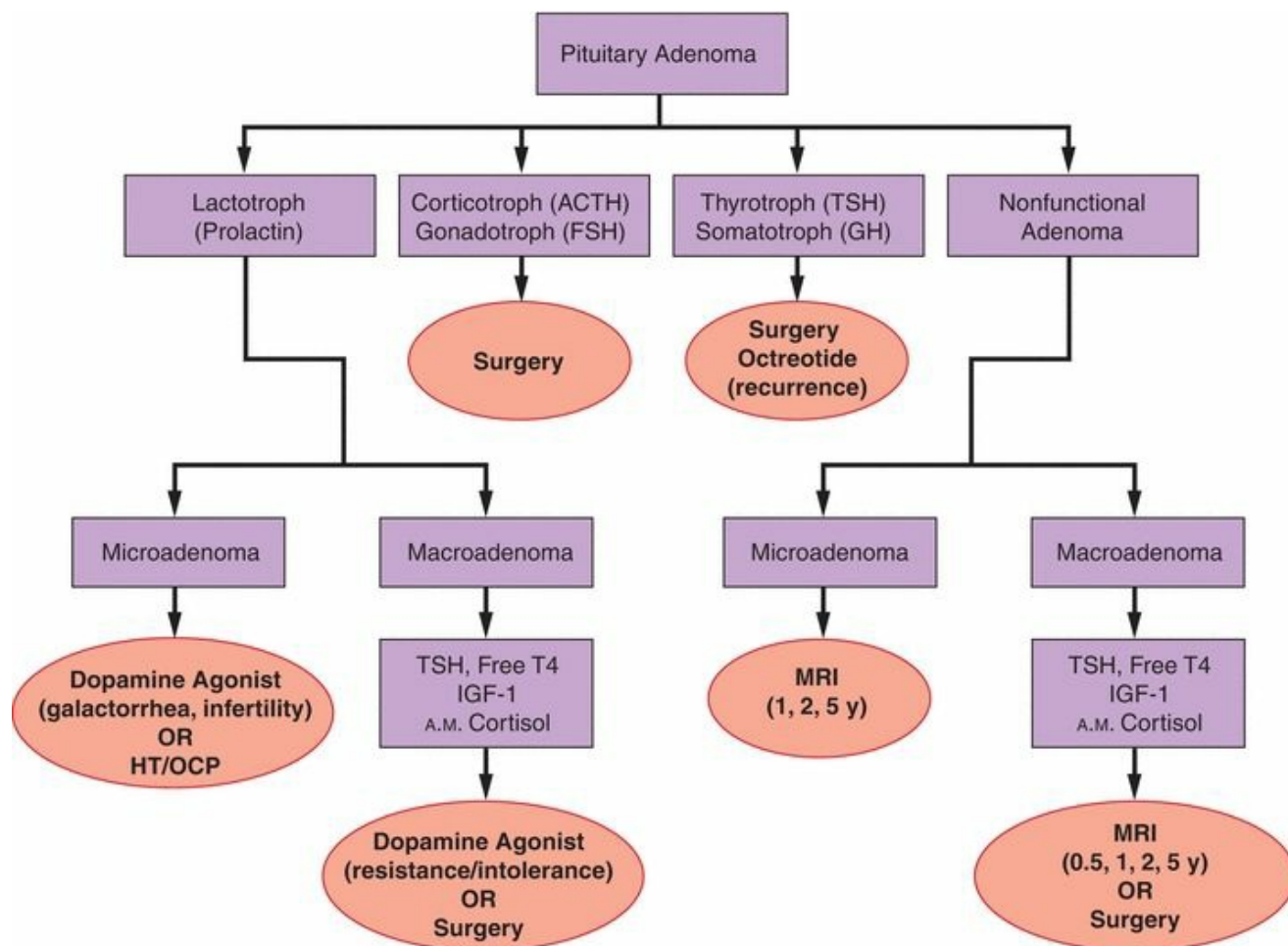
## Management During Pregnancy

Not surprisingly, given the effectiveness of dopamine agonist treatment in restoring ovulation and fertility in women with hyperprolactinemia, many women with functional lactotroph adenomas become pregnant. Overall, approximately 80% of hyperprolactinemic women, with or without adenomas, achieve pregnancy with dopamine agonist treatment.<sup>332,333,334</sup> Understandably, because the normal pituitary gland approximately doubles in size by the third trimester of pregnancy<sup>335</sup> and estrogen levels are quite elevated throughout, there is some increase in the risk for tumor growth during pregnancy. The risk for clinically significant growth in women with microadenomas is extremely low—only approximately 1–2%.<sup>336</sup> About 5% will develop asymptomatic tumor enlargement (as determined by imaging), and essentially none will ever require surgical intervention. The risk is significantly higher (approximately 15–20%) in those with macroadenomas.<sup>333,336</sup> Nevertheless, serial prolactin measurements during pregnancy are unnecessary.

**Regardless of the size of the adenoma, there is no indication for treatment with dopamine agonists or for imaging during pregnancy in the absence of symptoms; treatment may be safely discontinued when pregnancy is established.** In women with microadenomas, the serum prolactin should be measured approximately 2 months after delivery or the cessation of nursing, and, if still elevated, treatment with a

dopamine agonist, hormone therapy, or hormonal contraception can resume, according to the patient's needs. In women with macroadenomas, an interval of treatment with a dopamine agonist before pregnancy is advisable, to shrink the tumor and reduce the associated risk. In those with macroadenomas that fail to shrink with treatment, pregnancy should be avoided until after surgical debulking since medical treatment is not likely to be effective if symptoms develop.

In the few women with macroadenomas who experience significant tumor growth during pregnancy, headaches usually precede visual disturbances, and both may occur in any trimester. The headaches have no specific characteristics and vary in intensity, location, and character. Bitemporal hemianopsia (tunnel vision) is the classic visual impairment, but other defects can occur. The symptoms typically regress promptly with resumption of dopamine agonist treatment. Although seldom necessary, such treatment poses no risk to the fetus.<sup>35,332,337,338,339</sup> Amniotic fluid prolactin, with its presumed actions on the regulation of amniotic fluid water and electrolyte balance, derives from the decidua, and its secretion is controlled by estrogen and progesterone, not by dopamine, which has no effect on amniotic fluid prolactin levels. **Breastfeeding poses no significant risk for tumor growth in women with microadenomas or macroadenomas that remain asymptomatic during pregnancy, but is contraindicated for those with neurologic symptoms at the time of delivery.**<sup>340</sup> Dopamine agonist treatment should not resume until after cessation of nursing (**Figure 10.6**).



**FIGURE 10.6**

Pituitary Incidentaloma MRI has a high sensitivity for detecting small lesions and may reveal a pituitary tumor when the head is imaged for reasons other than suspected pituitary disease. In sum, 13 autopsy studies involving the examination of more than 10,000 pituitary glands identified more than 1,000 unsuspected microadenomas and 3 macroadenomas, yielding an overall prevalence of pituitary “incidentaloma” of approximately 10%.<sup>341</sup>

Relatively little is known about the fate of such common asymptomatic sellar masses. However, in one series involving 506 patients, all having serum prolactin levels less than 100 ng/mL and no evidence of other pituitary hormone hypersecretion or deficiency, 258 (almost 51%) had immediate surgery and 248 received expectant management for an average of 27 months. In those receiving surgery, 209 (81%) of the lesions were nonfunctional adenomas. Among those followed expectantly with serial imaging, the lesions grew in 30 (12%), shrunk in 29 (12%), and remained unchanged in all others. Among the lesions that grew in size over the course of surveillance, 20 were initially  $\geq 10$  mm, 10 were less than 10 mm, and only 3 grew to more than 10 mm over

65–84 months of observation.<sup>342</sup> In 2 smaller studies involving a total of 98 patients with pituitary incidentalomas, 10/41 (24%) tumors  $\geq 10$  mm and only 1 of 57 smaller tumors ( $< 2\%$ ) grew over 2–11 years of observation.<sup>343,344</sup>

Based on the available data, it generally is recommended that patients with pituitary incidentalomas  $\geq 10$  mm in size be evaluated in the same way as those with symptomatic macroadenomas, with periodic pituitary function tests and visual field examination, because such tumors are more likely to be associated with abnormalities in pituitary hormone secretion and to enlarge over time. Those with functional macroadenomas should be treated accordingly, and those with nonfunctional tumors can be followed with serial testing and imaging at 6 months, 1 and 2 years, and less frequently thereafter; any associated hormone deficiencies should be treated appropriately. In patients with smaller incidentalomas ( $< 10$  mm), a serum prolactin should be obtained, but other endocrine evaluation is unnecessary when there are no clinical signs or symptoms to suggest a functional tumor.<sup>345</sup> In the absence of any clinical or endocrine abnormalities, MRI can be repeated once after 1–2 years to identify the very few that may exhibit significant growth.

## Empty Sella Syndrome

The “empty sella syndrome” is a misnomer because the sella turcica is not, in fact, empty. The sella is enlarged and appears empty on imaging because it contains cerebrospinal fluid (CSF), still within the subarachnoid space but extending downward into the pituitary fossa. The disorder is included here, in our discussion of pituitary adenomas, because it is most commonly iatrogenic, consequent to previous removal or destruction of a pituitary adenoma by surgery or radiation. A less common mechanism for an empty sella is of pituitary infarction. Alternatively, an empty sella may result from a congenital defect in the sellar diaphragm (“primary empty sella”) allowing encroachment of the subarachnoid space into the pituitary fossa; long-term compression of otherwise normal pituitary tissue against the sellar floor results in flattening of the tissue, and the sella itself may become demineralized due to the increased pressure within the pituitary fossa.

In autopsy studies, the prevalence of an empty sella is approximately 5%, with the prevalence being disproportionately higher in women (nearly 85% of affected individuals are women).<sup>346</sup> In women presenting with amenorrhea and galactorrhea, the prevalence of empty sella is between 4% and 15%.<sup>313,347</sup> Not surprisingly, the syndrome may coexist with an adenoma and, less commonly, with deficiencies in pituitary hormone secretion that can be severe.<sup>348</sup> However, the condition usually is quite benign and does not progress to pituitary failure. There is no convincing evidence to indicate that a primary empty sella causes pituitary insufficiency.

Because of the possibility of a coexisting adenoma, patients with hyperprolactinemia and an empty sella should undergo annual surveillance (prolactin assay and imaging) for a few years to detect any evidence of tumor growth. Treatment for the condition is dictated by the associated symptoms and disturbances in pituitary hormone secretion.

## **Sheehan Syndrome**

Acute infarction and ischemic necrosis of the pituitary gland resulting from postpartum hemorrhage and consequent hypovolemic hypotension are known as Sheehan syndrome, which remains one of the most common causes of hypopituitarism in the underdeveloped or developing countries.<sup>349,350</sup> Failed lactation after delivery is the classical and earliest presenting symptom. The rest of the clinical picture varies with the severity of the pituitary insult, ranging from severe hypopituitarism soon after delivery, manifesting as lethargy, anorexia, and weight loss, to secondary amenorrhea, loss of sexual hair, and less severe symptoms of fatigue that emerge weeks and months later.<sup>351,352,353</sup> Deficiencies in GH, prolactin, and gonadotropins are most common, although the majority also exhibit ACTH and TSH deficiencies. Approximately one-third of patients may have hyponatremia, but diabetes insipidus is almost never observed.<sup>352,353</sup> A partially or completely empty sella is a common later finding.

The evaluation and treatment of Sheehan syndrome are no different from that for other causes of hypopituitarism, with one caveat. Any ACTH stimulation test that may be performed to detect a secondary adrenal insufficiency should be postponed until approximately 6 weeks after delivery. Adrenal atrophy due to chronic ACTH deficiency, resulting in the inability to increase cortisol secretion normally in response to an acute ACTH stimulus, requires time to develop. Earlier testing therefore may yield inaccurate (false negative) results.

## **Infiltrative Pituitary Lesions**

Infiltrative pituitary lesions that by damaging the gonadotrophs may cause hypogonadotropic hypogonadism and thereby amenorrhea include hemochromatosis and lymphocytic hypophysitis.

### **Hemochromatosis**

Hereditary hemochromatosis is an inherited autosomal recessive disorder caused by mutations in the HFE gene (on chromosome 6). In individuals homozygous for the mutant gene, an alteration in the size or shape of the HFE (hemochromatosis) protein prevents its transport to the cell surface where it normally interacts with the transferrin receptor, thereby interfering with the regulation of transmembrane iron transport and entry into the



cells.<sup>354</sup> Excessive absorption of dietary iron is the consequence, leading to parenchymal iron overload and subsequent tissue damage. In the pituitary, gonadotrophs are the most common cell type affected, resulting in hypogonadotropic hypogonadism<sup>355</sup>; TSH and ACTH deficiencies are less common. An acquired form of hemochromatosis may result from frequent transfusions in individuals with transfusion-dependent severe anemias (such as sickle cell disease, beta thalassemia major, aplastic anemia).

The best screening test for hereditary hemochromatosis is a fasting transferrin saturation (a ratio of serum iron to total iron binding capacity, expressed as a percentage)<sup>356</sup>; values greater than 45% are an indication for proceeding with HFE genotyping to establish the diagnosis.<sup>357</sup> Early diagnosis and treatment (periodic phlebotomy, chelation therapy) help to prevent serious multisystem end-organ damage relating to excess iron deposition; organs particularly susceptible to iron toxicity are the liver, pancreas, anterior pituitary, and heart. Although hereditary hemochromatosis is an uncommon cause of hypogonadotropic hypogonadism, some have suggested that iron studies should be performed in all patients with hypopituitarism and normal imaging.<sup>358</sup>

## **Lymphocytic Hypophysitis**

Lymphocytic hypophysitis is a rare autoimmune disorder causing enlargement of the pituitary that mimics a pituitary tumor, most often occurring during pregnancy or in the first 6 months postpartum.<sup>359,360</sup> The chronic inflammatory process results in focal or diffuse adenohypophysial destruction of varying severity and subsequent fibrosis. In the initial phase of hypophysitis, hyperprolactinemia is common, followed by progressive hypopituitarism. The disorder should be considered in women with sellar enlargement soon after pregnancy and in those with hypogonadism and a coexisting autoimmune disorder. Patients with symptoms and signs of pituitary enlargement and suprasellar extension can be treated by transsphenoidal surgery, dopamine agonists, anti-inflammatory or immunosuppressive drugs, or pituitary radiotherapy.<sup>361</sup> Granulomatous infiltrative processes of sarcoidosis involving the hypothalamus and/or the pituitary gland and presenting as amenorrhea have been reported.<sup>362</sup> Similarly, cases of tuberculous meningitis and intrasellar tuberculoma resulting in amenorrhea have also been described.<sup>363,364</sup>

# Disorders of Hypothalamic Function

Hypothalamic dysfunction is one of the most common causes of secondary amenorrhea. In its most severe form, commonly known as **hypothalamic amenorrhea**, the HPO axis is profoundly suppressed—abnormally low levels of hypothalamic GnRH secretion stimulate only basal amounts of pituitary gonadotropin secretion, which, in turn, fail to stimulate ovarian follicular development, resulting in very low levels of estrogen production.<sup>365</sup> The clinical manifestations of dysfunctional hypothalamic GnRH secretion depend on the extent to which gonadotropin secretion is suppressed, much like in women with hyperprolactinemia and probably involving similar mechanisms. A minor disturbance in pulsatile hypothalamic GnRH secretion may result only in poor luteal function due to decreased LH stimulation of corpus luteum progesterone secretion, whereas a more significant dysfunction will result in disordered follicular development and chronic anovulation presenting as oligomenorrhea or amenorrhea, as discussed in an earlier section of this chapter devoted to the evaluation of ovarian function (see Chronic Anovulation). The primary focus here is on the more severe disorder, hypothalamic amenorrhea, characterized by overt hypogonadotropic hypogonadism. Other rare hypothalamic causes of amenorrhea include genetic mutations resulting in a congenital GnRH deficiency and infiltrative diseases involving the hypothalamus such as lymphoma, Langerhans cell histiocytosis, and sarcoidosis.

## Hypothalamic Amenorrhea

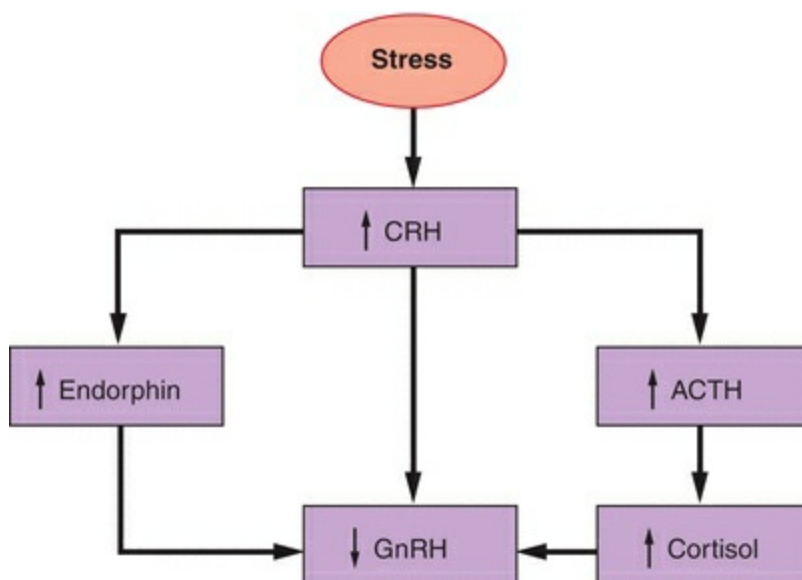
**Hypothalamic amenorrhea is a diagnosis of exclusion, based on findings of low or normal serum FSH concentration, despite low levels of estrogen production, in the absence of any sellar mass lesion or reason to suspect other rare pituitary causes of hypogonadotropic hypogonadism.**

Hypothalamic amenorrhea frequently is associated with extreme physical, nutritional, or emotional stress, suggesting it represents a functional suppression of reproduction as a psychobiologic response to life events.<sup>366</sup> Affected women frequently are underweight (e.g., <10% below ideal body weight), report recent weight loss, or engage in regular strenuous exercise; despite the recognized associations, it is important to appreciate that the critical threshold weight and the amount of weight loss or exercise required to induce amenorrhea vary significantly among individual women. Women with hypothalamic amenorrhea often exhibit abnormal eating patterns and generally expend more calories in aerobic activity and have a higher fiber intake and lower percent body fat than normally cycling women.<sup>367</sup> Many have endocrine, metabolic, and psychological characteristics that suggest a subclinical eating disorder.<sup>368,369</sup> However, in others with hypothalamic amenorrhea, no obvious mechanism or precipitating event

can be identified.

Regardless of the cause, the large majority of women with hypothalamic amenorrhea exhibit an abnormal pattern of hypothalamic GnRH secretion, as inferred from the pattern of pulsatile gonadotropin secretion. Some have no detectable gonadotropin secretory pulses (8%), and others exhibit low-frequency/low-amplitude (27%), low-amplitude/normal-frequency (8%), low-frequency/normal-amplitude (43%), or normal-frequency/normal-amplitude pulses (14%); different patterns may be observed over time.<sup>370</sup> Differences in the glycosylation of secreted gonadotropins, resulting in reduced bioactivity, also help to explain why those with normal immunoactive serum gonadotropin levels are nonetheless hypogonadal.<sup>62,371</sup> Almost half exhibit augmented LH secretion during sleep and higher serum levels of FSH than LH, as is observed in pubertal girls.

Observations of increased cortisol secretion in women with idiopathic hypothalamic amenorrhea suggest that stress may interrupt reproductive function indirectly by activating the hypothalamo-pituitary-adrenal axis.<sup>372,373,374</sup> Evidence suggesting the mechanism derives from experiments in nonhuman primates demonstrating that CRH inhibits gonadotropin secretion, probably by augmenting endogenous central opioid secretion (endorphins) (Figure 10.7).<sup>375</sup> Interestingly, cortisol levels return to normal months before the return of menses in women with hypothalamic amenorrhea, further suggesting the importance of stress, mediated via the adrenal axis.<sup>376</sup> Other studies indicate that increased hypothalamic dopaminergic inhibition of pulsatile GnRH secretion may be involved in at least some women with hypothalamic amenorrhea.<sup>377</sup>



**FIGURE 10.7**

The natural history of hypothalamic amenorrhea has been examined in a few studies that have followed women with the disorder over time. In those with hypothalamic amenorrhea associated with psychological stress or weight loss, spontaneous recovery with resumption of menses was observed in over 70% after 6–8 years of observation.<sup>378,379</sup> Women who recovered HPO function had higher BMI and lower cortisol levels than those who did not. Others have observed that women with an established cause or inciting event for their hypothalamic amenorrhea (such as stress, weight loss, or an eating disorder) were more likely to recover than those in whom no cause could be identified.<sup>380</sup> In patients with eating disorders, a return of menstrual function is associated with weight gain and recurrent amenorrhea with weight loss.<sup>381</sup>

## Eating Disorders

St. Wilgefortis was the seventh daughter of the King of Portugal, living around the year 1000. When confronted with an arranged marriage (despite her vow of virginity to join a convent), she turned to intense prayer, became ascetic and anorexic, and developed a diffuse growth of body hair, including a beard. Confronted with this new appearance, the King of Sicily withdrew his offer of marriage, and Wilgefortis's father had her crucified. Around 1200, the legend of Wilgefortis spread throughout Europe.<sup>382</sup>

St. Wilgefortis became a symbol, a woman who liberated herself from the burdens of womanhood, and became a protectress of women with sexual problems, including those associated with childbirth. Women who wished to free themselves from their husbands prayed to her, because she had successfully resisted both a father and an unwelcome suitor. In England, she was known as St. Uncumber because women believed she could uncumber them from their husbands. The medieval explanation (with ascendancy to sainthood) for a young girl's response (anorexia nervosa) to her fears of marriage and sexuality is still, to some extent, viable today, as anorexia can be the expression of the need to exert control over some facet of a rapidly changing and increasingly demanding and stressful life.

Our contemporary culture is obsessed with weight loss, clearly exhibited by the constant introduction and wide promotion of new fad diets, exercise regimens and apparatus, and the public adulation of models, actors, and athletes. Taken together, they send an unequivocal and unfortunate message to maturing adolescents, as reflected by the results of a national Youth Risk Behavior Survey taken in 2005: 38% of adolescent girls (in grades 9–12) considered themselves overweight, 62% were trying to lose weight, 17% had recently fasted for 24 hours or more, 8% had taken diet pills or similar products, and 6% had recently tried to induce vomiting or taken laxatives to lose weight or keep from gaining weight.<sup>383</sup> Although the estimated lifetime prevalence of eating disorders in women is relatively low, ranging between 0.3% and 2%,<sup>384,385,386,387</sup> these

disturbing statistics reveal the size of the population at risk.

In addition to cultural influences, other psychological, biologic, genetic, and social factors likely contribute to the development of eating disorders. Several have been associated with their development, including a history of dieting,<sup>388</sup> preoccupation with weight,<sup>389</sup> athletic and artistic pursuits that favor leanness or involve subjective judging, and, possibly, sexual abuse.<sup>389</sup> Young women having a first-degree relative with an eating or affective disorder or alcoholism are at increased risk for developing an eating disorder. Linkage analyses have identified possible susceptibility loci for anorexia nervosa on chromosome 1 and for bulimia nervosa on chromosome 10.<sup>390,391</sup> Affective, anxiety, and obsessive-compulsive disorders, personality disorders, and substance abuse are common in women with eating disorders.<sup>392</sup> Family stresses relating to high perceived parental expectations (for success, achievement, and appearance), poor communication, and marital tension also may play a role.

The clinical spectrum of eating disorders ranges from a limited period of amenorrhea associated with a crash diet in otherwise normal women to the grossly underweight anorexic having a distorted body image and the bulimic who cycles regularly between binge eating and purging behaviors. The specific diagnostic criteria for anorexia nervosa and bulimia nervosa are defined in the Diagnostic and Statistical Manual of Mental Disorders (DSM-IV) and are briefly summarized here. The DSM-IV categorizes those with clearly abnormal eating patterns and weight control habits that do not meet the specific criteria for anorexia nervosa or bulimia nervosa as having an “eating disorder, not otherwise specified.”<sup>393</sup>

## **Anorexia Nervosa**

### **Key Points: Anorexia Nervosa**

- Refusal to maintain body weight within a normal range for height and age (<85% of ideal body weight)
- Fear of gaining weight or becoming fat, even though underweight
- Distorted body image, with undue importance on weight or shape
- In postmenarchal females, amenorrhea

Two subtypes of anorexia nervosa have been defined—restricting and binge/purging. In the first, a restriction of food intake is the primary method for achieving weight control. In the second, bingeing and purging, via self-induced vomiting or the use of laxatives or

diuretics, is the primary method for controlling weight. In both types, compulsive exercise may be an additional behavioral strategy for maintaining or losing weight.

The diagnostic criteria for bulimia nervosa are distinct from those for anorexia nervosa, primarily in that they do not include low body weight or amenorrhea.

## **Bulimia Nervosa**

### **Key Points: Bulimia Nervosa**

- Episodic binge eating, consuming abnormally large amounts of food, with a sense of lack of control.
- Recurrent compensatory behavior, including self-induced vomiting or misuse of laxatives, diuretics, or other medications, fasting, or excessive exercise.
- Binging and purging behaviors occurring at least twice per week, on average for an interval of 3 months or more.
- Dissatisfaction with body weight or shape.
- The behavior does not occur exclusively during episodes of anorexia nervosa.

Two subtypes are again described—purging and nonpurging. In the first, the purging behavior includes regular self-induced vomiting or the misuse of laxatives or diuretics. In the second, other compensatory behaviors predominate, such as exercise.

The clinical symptoms of restrictive anorexia nervosa include weight loss that frequently dates from a specific event like an illness, insensitive comment, rebuke, or loss. Amenorrhea typically precedes weight loss, which begins with dieting and specific restriction of fat intake. Affected women often admit fatigue, nausea, early satiety, or bloating after meals. They exhibit a distorted body image, denial, and disordered thinking and frequently use exercise as an additional weight control strategy. In women with anorexia nervosa, the physical examination may reveal hypotension, bradycardia, low body temperature, dry skin, and lanugo (fine, soft hair on the back, buttocks, and extremities). Those with bulimia nervosa exhibit impulsive and addictive qualities to their behaviors, an inability to control binge eating and purging, and frequently use cigarettes, alcohol, and other drugs. Many have irregular menses, but not amenorrhea, and in most, weight fluctuates but is not abnormally low. Those with bulimia nervosa may have parotid gland hypertrophy and erosion of their teeth enamel (from frequent vomiting).

The metabolic abnormalities associated with anorexia nervosa reflect dysfunctional hypothalamic regulation of appetite, thirst, temperature, sleep, autonomic balance, and

endocrine secretion.<sup>394</sup> The clinical consequences can be severe and even life-threatening. The associated endocrine abnormalities include low serum FSH, LH, estradiol, IGF-1, and leptin concentrations and increased cortisol levels; prolactin, TSH, and T4 levels are normal, but the T3 level is low, and reverse T3 (rT3) is high (rT3 is an isomer of T3, derived from T4, that binds but does not activate thyroid hormone receptors). With weight gain, all of the metabolic and endocrine abnormalities resolve. Even though normal gonadotropin secretion may be restored with weight gain, approximately one-third remains amenorrheic, likely reflecting persistent hypothalamic dysfunction.<sup>395</sup>

The treatment of anorexia nervosa and bulimia nervosa is complex, but generally requires nutrition, medical monitoring, and cognitive behavioral therapy in a multidisciplinary approach involving a physician, a dietitian, and a mental health professional. Antidepressant medications (primarily selective serotonin reuptake inhibitors) can be an important part of the management of bulimia nervosa, but have less value in anorexics. In those with anorexia nervosa, weight gain is the key to a successful outcome. Patients with severe medical or psychological symptoms may require hospitalization. Approximately half of patients with anorexia nervosa have good outcomes, as defined by weight gain and a return of menses, and about 25% improve but also have relapses; outcomes are poor in the remaining 25%.<sup>396</sup> Poor outcomes have been associated with older age at onset, longer duration of illness, lower nadir in weight, and lower body fat after weight gain.<sup>397</sup>

Low bone mass, osteopenia and osteoporosis, and an enhanced fracture risk are among the most serious complications of anorexia nervosa, the inevitable consequence of the combined adverse effects of severe malnutrition and estrogen deficiency. Although both contribute to bone loss, malnutrition clearly has the greater effect and importance.<sup>398,399</sup> In those who do not gain weight or resume menses, bone mineral density decreases approximately 2.5% annually in both the spine and the hip. Conversely, in those who gain weight and resume menses, bone density increases by approximately the same amount in both locations. In women who resume menses, spine bone density increases, independent of weight gain, and in women who gain weight, hip bone density increases, regardless whether they resume menses.<sup>400</sup> By itself, hormone therapy has little or no benefit. Treatment with oral contraceptives cannot prevent progressive bone loss in women with anorexia nervosa and generally has little value,<sup>401,402,403</sup> except perhaps in those with extremely severe illness (those below 70% of ideal body weight).<sup>404</sup> Undernourished women with eating disorders who do not achieve the rapid gain in bone density that normally occurs during adolescence may always have reduced bone density, even if they recover and resume normal menses.<sup>405</sup>

## Eating Disorders and Pregnancy

The caloric requirements of pregnancy, the changes in body shape, and the need to gain weight present particular challenges for women with eating disorders. For some, pregnancy may offer an opportunity or reason for recovery, but for others, it increases stress and risk. In general, women with restrictive behaviors tend to gain relatively little weight during pregnancy and those with bulimic behaviors often gain excessive weight.

Caloric restriction and compensatory behaviors such as purging pose risks for both mother and fetus. Anorexia nervosa increases the risk for maternal malnutrition, fetal growth restriction, and low birth weight. A low prepregnancy weight and inadequate weight gain during pregnancy each independently increase the risk of preterm birth.<sup>406</sup> The incidence of hyperemesis gravidarum, miscarriage, preterm birth, cesarean delivery, and postpartum depression is increased in pregnant women with eating disorders.<sup>407,408,409,410</sup> Women with anorexia nervosa in remission at the time of conception gain more weight and have higher birth weights than those with active illness.<sup>411</sup> In most women with bulimia nervosa, symptoms improve during pregnancy, but often recur or worsen postpartum.<sup>412</sup>

Overall, the best outcomes are achieved when illness is well-controlled before pregnancy. Consequently, treatment for anovulatory infertile women with eating disorders should focus first on management of their underlying illness before turning to ovulation induction.<sup>413</sup> The goal of pregnancy can be a strong motivational force and provides a unique opportunity for effective intervention.

During pregnancy, diet, weight gain, and fetal growth should be carefully monitored and nutritional counseling provided. Calcium supplementation is particularly important since most women with established eating disorders have low bone mass, which can further decline during pregnancy and lactation. As in nonpregnant women with eating disorders, a team management approach works best. Active management must continue into the postpartum period, when symptoms may resurface, and should involve the pediatrician because women with eating disorders are more likely to underfeed their babies.<sup>414</sup>

## Exercise and Amenorrhea

Soranus of Ephesus in the first century AD observed in his famous treatise, “On the Diseases of Women,” that amenorrhea is frequently observed in the youthful, the aged, the pregnant, in singers, and in those who take much exercise. In contemporary culture, a substantial proportion of reproductive-age women engage in some kind of regular exercise. Whereas exercise clearly offers significant health benefits, excessive exercise also may result in infertility or amenorrhea and, in adolescents, may even cause delayed



puberty.<sup>415</sup>

Women who are involved in strenuous recreational exercise or other forms of demanding physical activity, such as dancing, have a high prevalence of menstrual irregularity and amenorrhea. As much as two-thirds of runners who menstruate exhibit a short luteal phase or anovulatory cycles.<sup>416,417</sup> Typically, previously normal cycles become irregular after exercise begins and progress to amenorrhea as the intensity of exercise increases, particularly when accompanied by weight loss. Physical training that begins before menarche may delay its onset by as much as 3 years. **Exercise alone does not cause amenorrhea; the specific type and intensity of exercise are important.** Physical activities associated with a low body weight and high lean body mass (running, dance, gymnastics, figure skating) are associated with a higher incidence of amenorrhea than activities like swimming. Low body weight, by itself, unless extreme, also does not cause amenorrhea, because the effect of exercise on menstrual pattern varies significantly among women having a similar BMI. **The potential adverse effects of intense exercise and low body weight on menstrual function are synergistic.**

The critical weight hypothesis holds that the onset and regularity of menstrual function require that weight remains above a critical threshold level, with a corresponding critical level of body fat, which is estimated at 17% for menarche and at 22% for regular menstruation.<sup>418</sup> According to this hypothesis, excessive exercise or malnutrition may decrease the amount of body fat to below threshold values, resulting in delayed menarche in adolescents and in amenorrhea in postpubertal women. Logically, those at or near their critical thresholds of weight and body fat content would be at the greatest risk for loss of menstrual function.<sup>419</sup> Critics of the hypothesis acknowledge the correlation between body fat content and menstrual function, but deny any cause-effect relationship.<sup>420</sup> Indeed, normal and abnormal menstrual function may be observed at widely varying levels of body weight and fat content. However, the discovery of leptin (secreted by adipocytes in proportion to body fat stores) and of leptin receptors in the hypothalamus, revealing a feedback mechanism for the central regulation of body fat content, has stimulated renewed interest in the critical weight hypothesis (see [Chapter 19](#)).

In addition to the influence of weight and body fat on menstrual function, stress and energy expenditure exert important and independent effects, illustrated by the observation that menses often return in dancers during intervals of rest associated with injury, in the absence of any change in body weight or fat content.<sup>421</sup> Therefore, it is not surprising that women with low body weight and fat content who engage in strenuous physical activity are highly susceptible to anovulation and amenorrhea. **It appears that a negative energy balance, resulting when the level of energy expenditure exceeds**

**the available supply (derived both from intake and available stores), predisposes to a disruption in pulsatile gonadotropin secretion and a loss of menstrual function.**<sup>422</sup>

Other mechanisms that may help to explain the effects of exercise on menstrual function involve the actions of endogenous opioids, activation of the adrenal axis, and leptin. Substantial evidence suggests that secretion of endogenous hypothalamic opioids, which inhibit GnRH secretion, increases after exercise.<sup>423,424,425,426</sup> Cortisol levels are increased in hypothalamic amenorrhea (including that relating to exercise),<sup>373,427,428</sup> suggesting increased activity in the adrenal axis, mediated by CRH, which inhibits GnRH secretion.<sup>375</sup> Leptin levels are low in exercising amenorrheic women, lower than can be attributed to body fat content alone.<sup>429</sup> Exercising amenorrheic women do not exhibit a normal diurnal leptin rhythm.<sup>430</sup> Moreover, treatment with exogenous recombinant human leptin can restore gonadotropin pulsatility, follicular development, and ovulatory function in exercising amenorrheic women.<sup>431</sup> A decrease in leptin levels, resulting from low body fat stores and a negative energy balance, may thus suppress the HPO and thyroid axes and stimulate the adrenal axis, thereby producing many of the endocrine features observed in amenorrheic female athletes.

A unifying hypothesis focuses on the importance of energy balance.<sup>432,433</sup> When energy demands are high, as in exercise, or supplies are insufficient, as in eating disorders, reproduction is suspended in favor of more essential metabolic functions. Teleologically, the concept makes sense; adaptations to stress also inhibit menstrual function because conditions do not favor successful reproduction.

Regardless whether the critical factor is body weight, percent fat content, or energy balance, and whether endogenous opioids, CRH, and leptin mediate the effect, the mechanism by which exercise disturbs normal menstrual function relates directly to changes in the pattern of hypothalamic GnRH secretion, which may vary with body composition. In amenorrheic athletes with low body weight, both LH pulse frequency and amplitude are decreased; pituitary sensitivity to exogenous GnRH also is increased, further indicating that decreased gonadotropin levels result from decreased endogenous GnRH stimulation.<sup>368</sup> In contrast, when exercise is not weight-bearing and leanness is therefore less important, as in competitive swimmers, LH levels often are modestly elevated rather than suppressed, and estradiol concentrations are normal, suggesting a less severe disturbance in GnRH pulse rhythm that results in chronic anovulation and amenorrhea, but not in hypogonadotropic hypogonadism (hypothalamic amenorrhea) as more often occurs in runners and dancers.<sup>434</sup>

Because most women with exercise-induced amenorrhea are estrogen deficient, they are at risk for its natural clinical consequences, including genitourinary and breast atrophy and bone loss with consequent low bone mass. Unlike menopausal women,

vasomotor symptoms are not a feature of hypogonadism due to hypothalamic amenorrhea, a distinction that is attributable to the underlying hypothalamic dysfunction in the latter. **It is important to emphasize that the beneficial effects of weight-bearing exercise on the bone are not sufficient to prevent the adverse effects of estrogen deficiency, particularly in adolescents.** In general, hypogonadism has greater detrimental effects on trabecular bone than on cortical bone. However, because skeletal loading patterns differ with the type of exercise, exercising estrogen-deficient women exhibit site-specific differences in bone density. Gymnasts have a higher bone density in the spine than the runners, despite similar menstrual patterns and body fat.<sup>435</sup> In ballet dancers, cortical bone density may be normal or increased at weight-bearing sites, such as the proximal femur, but trabecular bone density is decreased in the lumbar spine.<sup>436</sup> Rowers may accrue greater bone density in the lumbar spine due to the mechanical loading produced in their exercise.<sup>437</sup> However, the normal stress-induced compensatory changes in bone density also may be impaired or prevented by estrogen deficiency.<sup>436</sup> Fractures, particularly stress fractures, are common in athletes, but more common in those with abnormal eating patterns,<sup>438,439</sup> possibly because a negative energy balance results in low rates of bone turnover and favors resorption.

For some women, an explanation of the need to maintain caloric intake at a level in balance with energy expenditure encourages behavioral modifications (increased caloric intake and/or a decrease in exercise) that may restore menses.<sup>440</sup> However, most women with exercise-induced hypothalamic amenorrhea understandably are resistant to the suggestion that they gain weight or reduce or stop exercising. For many, exercise also is an important stress management strategy. It is helpful to explain the effects of diet, exercise, and hormones and to emphasize the importance of building bone early in life; almost all of hip and vertebral bone mass accumulates by late adolescence (age 18), and the early postmenarchal years (age 11–14) are especially important.<sup>441,442</sup>

Bone loss is the most obvious, immediate, and demonstrable consequence of exercise-induced hypothalamic amenorrhea. **A baseline bone density measurement revealing significantly low bone mass compared to age- and gender-matched controls (BMD Z score of  $<-2.0$ ) is associated with an increased risk for debilitating stress fracture and can help to illustrate and to emphasize the need for a change in lifestyle and habits or for an intervention such as hormone therapy.** Subsequent periodic measurements of bone density are useful for assessing for interval change and effectiveness of therapy. The increase in bone mineral density that typically accompanies a return of normal menses is significantly greater than can be achieved by treatment with estrogen or combined hormonal contraceptives,<sup>443,444,445,446</sup> probably because normal bone metabolism requires both adequate nutrition (supporting bone formation) and estrogen (decreasing bone resorption). Nonetheless, in those unable or

unwilling to make the lifestyle changes that might restore gonadal function, exogenous estrogen (plus progestin to ensure endometrial protection, either as cyclic or continuous regimen) or a combination hormonal contraception (pill, vaginal ring, or patch) is indicated, particularly so if low BMD is diagnosed, according to the patient's needs and preferences. Those choosing physiologic hormone therapy must be cautioned that treatment will not prevent ovulation rendering the individual susceptible to possibility of an unplanned pregnancy if and when HPO function gets restored.<sup>447</sup> Resumption of spontaneous ovarian function remains the most effective strategy for improving skeletal mass in women with hypothalamic amenorrhea. Unscheduled and unanticipated menstrual bleeding is suggestive of resumption of ovarian function, and treatment may be discontinued for an interval of observation. For those who require reliable contraception, a low-dose oral contraceptive may be a preferred choice. Women should be informed that hormone therapy may cause modest increases in weight and fat mass, but also reassured that such minor changes in body composition likely will have little or no impact on physical performance.<sup>443</sup>

Supplemental calcium (1,000–5,000 mg daily) and vitamin D (1,000–2,000 IU daily) should be encouraged. Skeletal antiresorptive agents other than estrogen, such as bisphosphonates, are not a good choice for the prevention and treatment of low bone mass in premenopausal women with exercise-induced hypothalamic amenorrhea, for two reasons. First, they have low levels of bone formation and bone turnover and therefore respond poorly to antiresorptive therapy.<sup>445</sup> Second, bisphosphonates remain in the bone for 10 years or more and constantly leech into the circulation, most women with exercise-induced hypothalamic amenorrhea have not completed childbearing, and the effects of bisphosphonates on fetal skeletal development are unknown.<sup>448</sup>

Women with exercise-induced hypothalamic amenorrhea should be reassured that treatment aimed at inducing ovulation and restoring normal fertility is available. The ideal approach to ovulation induction in women with hypothalamic amenorrhea is to mimic the *in vivo* HPO axis through utilizing pulsatile GnRH (using a transdermal pump) in physiologic doses, which stimulates the release of pituitary gonadotropins, thereby achieving ovarian follicular development. While pulsatile GnRH may be considered as an optimal approach to achieve successful ovulation in women with hypothalamic amenorrhea,<sup>70</sup> due to restricted availability of GnRH for clinical use, treatment with exogenous gonadotropins is the most common treatment utilized to achieve ovarian stimulation because ovulation induction agents such as clomiphene citrate is typically ineffective in women with hypogonadotropic hypogonadism. Logically, if low endogenous estrogen levels have failed to stimulate the appropriate compensatory increase in gonadotropin secretion, there is little reason to believe that treatment with an estrogen antagonist such as clomiphene will do so. It may be useful to advise such women that whereas weight gain and a decrease in exercise may not restore

spontaneous ovulatory function and fertility, they may nonetheless result in sufficient improvement in hypothalamic function to allow them to respond to clomiphene and to avoid the rigors and risks of gonadotropin treatment.

## **Congenital GnRH Deficiency**

In rare individuals, hypothalamic amenorrhea results from a congenital GnRH deficiency relating to specific genetic mutations that prevent normal GnRH neuronal migration during embryogenesis or to mutations in the pituitary GnRH receptor. Although seldom necessary, the diagnosis of congenital GnRH deficiency can be inferred by demonstrating a complete lack of pulsatile LH secretion and little or no LH secretion in response to exogenous pulsatile GnRH treatment.<sup>449,450</sup> Congenital GnRH deficiency is more common in males than in females (5:1). In affected women, the gonads respond normally to exogenous gonadotropin stimulation, which can be used to induce pubertal changes as well as achieve ovulation and restore fertility, as in women with the more common causes of hypothalamic amenorrhea.

## **Kallmann Syndrome**

When congenital GnRH deficiency is associated with anosmia or hyposmia (an absent or grossly impaired sense of smell), the disorder is known as Kallmann syndrome.<sup>451</sup> The classical X-linked form of the disorder is caused by a variety of genetic mutations in the KAL gene (located on the short arm of the X chromosome, Xp22.3) encoding anosmin-1, a neural adhesion molecule that promotes migration of GnRH neurons, and olfactory neurons, from the olfactory placode into the hypothalamus during embryonic development.<sup>452</sup> Obligate female carriers in families with the X-linked form of the disorder have no recognizable specific phenotype. Kallmann syndrome also can be inherited in an autosomal dominant or recessive fashion. The autosomal dominant form has been linked to an inactivating mutation in the gene encoding the fibroblast growth factor-1 receptor (FGFR1). Mutations similar to but distinct from that in Kallmann syndrome, affecting only GnRH neuronal migration, offer a potential explanation for an isolated gonadotropin deficiency, unaccompanied by anosmia.

At puberty, both males and females with Kallmann syndrome usually present with delayed growth and sexual development. The presence of pubic hair, reflecting a normal adrenarche, helps to distinguish them from those with a constitutional delay of puberty in whom adrenarche typically also is delayed. However, the most distinguishing feature of Kallmann syndrome is the inability to perceive odors, such as coffee or perfume. Patients with the disorder also may have a family history of delayed puberty and other abnormalities, including cleft lip/palate, urogenital tract anomalies, or syndactyly.

## GnRH Receptor Mutations

More than 20 inactivating mutations in the GnRH receptor gene (GNRHR) have been described.<sup>453,454</sup> Some effectively prevent GnRH binding, some interfere with normal signal transduction, both resulting in resistance to GnRH stimulation, and others predispose to abnormal folding at the site of synthesis within the endoplasmic reticulum, leading to degradation before transport to the cell surface membrane.<sup>68</sup>

The phenotypic spectrum observed in individuals with GnRH receptor mutations ranges from a complete absence of sexual development to delayed puberty and generally correlates with the LH-secretory response to exogenous GnRH treatment. Standard treatments for hypogonadotropic hypogonadism, including hormone therapy and ovulation induction with exogenous gonadotropins, are effective. Specific evaluation aimed at identifying GnRH mutations might be considered when other family members are affected, for research purposes, but is not clinically necessary or indicated, at least not yet. Interestingly, a nonpeptide cell permeant GnRH receptor antagonist (IN3) has shown the ability to restore ligand binding and function for several naturally occurring mutant GnRH receptors in vitro, apparently by acting as a molecular chaperone, helping to properly arrange the mutant receptor and to usher it to the cell surface membrane. The discovery suggests that such “pharmacochaperones” may someday have therapeutic applications in patients with GnRH receptor mutations.<sup>68</sup>

# REFERENCES

1. **Shangold MM, Tomai TP, Cook JD, Jacobs SL, Zinaman MJ, Chin SY, Simon JA**, Factors associated with withdrawal bleeding after administration of oral micronized progesterone in women with secondary amenorrhea, *Fertil Steril* 56:1040, 1991.
2. **Nakamura S, Douchi T, Oki T, Ijuin H, Yamamoto S, Nagata Y**, Relationship between sonographic endometrial thickness and progestin-induced withdrawal bleeding, *Obstet Gynecol* 87:722, 1996.
3. **Rebar RW, Connolly HV**, Clinical features of young women with hypergonadotropic amenorrhea, *Fertil Steril* 53:804, 1990.
4. **Rarick LD, Shangold MM, Ahmed SW**, Cervical mucus and serum estradiol as predictors of response to progestin challenge, *Fertil Steril* 54:353, 1990.
5. **Sizonenko PC, Burr IM, Kaplan SL, Grumbach MM**, Hormonal changes in puberty. II. Correlation of serum luteinizing hormone and follicle stimulating hormone with stages of puberty and bone age in normal girls, *Pediatr Res* 4(1):36, 1970.
6. **Bentzen JG, Forman JL, Pinborg A, Lidegaard Ø, Larsen EC, Friis-Hansen L, Johannsen TH, Nyboe Andersen A**, Ovarian reserve parameters: a comparison between users and non-users of hormonal contraception, *Reprod Biomed Online* 25(6):612, 2012.
7. **Contreras P, Generini G, Michelson H, Pumarino H, Campino C**, Hyperprolactinemia and galactorrhea: spontaneous versus iatrogenic hypothyroidism, *J Clin Endocrinol Metab* 53:1036, 1981.
8. **Danziger J, Wallace S, Handel S, Samaan NG**, The sella turcica in primary end organ failure, *Radiology* 131:111, 1979.
9. **Sarlis NJ, Brucker-Davis F, Doppman JL, Skarulis MC**, MRI-demonstrable regression of a pituitary mass in a case of primary hypothyroidism after a week of acute thyroid hormone therapy, *J Clin Endocrinol Metab* 82:808, 1997.
10. **Poretsky L, Garber J, Kleefield J**, Primary amenorrhea and pseudoprolactinoma in a patient with primary hypothyroidism, *Am J Med* 81:180, 1986.
11. **Seppala M, Ranta T, Hirvonen E**, Hyperprolactinaemia and luteal insufficiency, *Lancet* 1:229, 1976.
12. **Corenblum B, Paireudeau N, Shewchuk AB**, Prolactin hypersecretion and short luteal phase defects, *Obstet Gynecol* 47:486, 1976.
13. **Biller BM, Baum HB, Rosenthal DI, Saxe VC, Charpie PM, Klibanski A**, Progressive trabecular osteopenia in women with hyperprolactinemic amenorrhea, *J Clin Endocrinol Metab* 75:692, 1992.
14. **Schlechte J, Walkner L, Kathol M**, A longitudinal analysis of premenopausal bone loss in healthy women and women with hyperprolactinemia, *J Clin Endocrinol Metab* 75:698, 1992.
15. **Smith TP, Suliman AM, Fahie-Wilson MN, McKenna TJ**, Gross variability in the detection of prolactin in sera containing big big prolactin (macroprolactin) by commercial immunoassays, *J Clin Endocrinol Metab* 87:5410, 2002.
16. **Ellis MJ, Reed MR, Livesey JH**, Cross-reactivities of macroprolactin and big-prolactin in three commercial immunoassays for prolactin: a chromatographic analysis, *Clin Biochem* 40:1285, 2007.
17. **Fahie-Wilson MN, John R, Ellis AR**, Macroprolactin; high molecular mass forms of circulating prolactin, *Ann Clin Biochem* 42:175, 2005.
18. **Hattori N, Inagaki C**, Anti-prolactin (PRL) autoantibodies cause asymptomatic hyperprolactinemia: bioassay and clearance studies of PRL-immunoglobulin G complex, *J Clin Endocrinol Metab* 82:3107, 1997.
19. **Leslie H, Courtney CH, Bell PM, Hadden DR, McCance DR, Ellis PK, Sheridan B, Atkinson AB**, Laboratory and clinical experience in 55 patients with macroprolactinemia identified by a simple polyethylene glycol precipitation method, *J Clin Endocrinol Metab* 86:2743, 2001.
20. **Gibney J, Smith TP, McKenna TJ**, Clinical relevance of macroprolactin, *Clin Endocrinol (Oxf)* 62:633, 2005.
21. **Yazigi RA, Quintero CH, Salameh WA**, Prolactin disorders, *Fertil Steril* 67:215, 1997.
22. **Lloyd RV, Chandler WF, Kovacs K, Ryan N**, Ectopic pituitary adenomas with normal anterior pituitary glands, *Am J Surg Pathol* 10:546, 1986.

23. **Stanisic TH, Donova J**, Prolactin secreting renal cell carcinoma, *J Urol* 136:85, 1986.
24. **Hoffman WH, Gala RR, Kovacs K, Subramanian MG**, Ectopic prolactin secretion from a gonadoblastoma, *Cancer* 60:2690, 1987.
25. **Kallenberg GA, Pesce CM, Norman B, Ratner RE, Silverberg SG**, Ectopic hyperprolactinemia resulting from an ovarian teratoma, *JAMA* 263: 2472, 1990.
26. **Palmer PE, Bogojavlensky S, Bhan AK, Scully RE**, Prolactinoma in wall of ovarian dermoid cyst with hyperprolactinemia, *Obstet Gynecol* 75:540, 1990.
27. **Cuellar FG**, Bromocriptine mesylate (Parlodel) in the management of amenorrhea/galactorrhea associated with hyperprolactinemia, *Obstet Gynecol* 55:278, 1980.
28. **Webster J, Piscitelli G, Polli A, Ferrari CI, Ismail I, Scanlon MF**, A comparison of cabergoline and bromocriptine in the treatment of hyperprolactinemic amenorrhea. Cabergoline Comparative Study Group, *N Engl J Med* 331:904, 1994.
29. **Verhelst J, Abs R, Maiter D, Van Den Bruel A, Vandeweghe M, Velkeniers B, Mockel J, Lamberigts G, Petrossians P, Coremans P, Mahler C, Stevenaert A, Verlooy J, Raftopoulos C, Beckers A**, Cabergoline in the treatment of hyperprolactinemia: a study in 455 patients, *J Clin Endocrinol Metab* 84:2518, 1999.
30. **Schade R, Andersohn F, Suissa S, Haverkamp W, Garbe E**, Dopamine agonists and the risk of cardiac-valve regurgitation, *N Engl J Med* 356:29, 2007.
31. **Zanettini R, Antonini A, Gatto G, Gentile R, Tesei S, Pezzoli G**, Valvular heart disease and the use of dopamine agonists for Parkinson's disease, *N Engl J Med* 356:39, 2007.
32. **Kars M, Delgado V, Holman ER, Feelders RA, Smit JW, Romijn JA, Bax JJ, Pereira AM**, Aortic valve calcification and mild tricuspid regurgitation but no clinical heart disease after 8 years of dopamine agonist therapy for prolactinoma, *J Clin Endocrinol Metab* 93:3348, 2008.
33. **Colao A, Galderisi M, Di Sarno A, Pardo M, Gaccione M, D'Andrea M, Guerra E, Pivonello R, Lerro G, Lombardi G**, Increased prevalence of tricuspid regurgitation in patients with prolactinomas chronically treated with cabergoline, *J Clin Endocrinol Metab* 93:3777, 2008.
34. **Roth BL**, Drugs and valvular heart disease, *N Engl J Med* 356:6, 2007.
35. **Ginsburg J, Hardiman P, Thomas M**, Vaginal bromocriptine—clinical and biochemical effects, *Gynecol Endocrinol* 6:119, 1992.
36. **Motta T, de Vincentiis S, Marchini M, Colombo N, D'Alberston A**, Vaginal cabergoline in the treatment of hyperprolactinemic patients intolerant to oral dopaminergics, *Fertil Steril* 65:440, 1996.
37. **Turkalj I, Braun P, Krupp P**, Surveillance of bromocriptine in pregnancy, *JAMA* 247:1589, 1982.
38. **Colao A, Abs R, Barcena DG, Chanson P, Paulus W, Kleinberg DL**, Pregnancy outcomes following cabergoline treatment: extended results from a 12-year observational study, *Clin Endocrinol (Oxf)* 68:66, 2008.
39. **Corenblum B, Donovan L**, The safety of physiological estrogen plus progestin replacement therapy and with oral contraceptive therapy in women with pathological hyperprolactinemia, *Fertil Steril* 59:671, 1993.
40. **Testa G, Vegetti W, Motta T, Alagna F, Bianchedi D, Carlucci C, Bianchi M, Parazzini F, Crosignani PG**, Two-year treatment with oral contraceptives in hyperprolactinemic patients, *Contraception* 58:69, 1998.
41. **Farhi DC, Nosanchuk J, Silverberg SG**, Endometrial adenocarcinoma in women under 25 years of age, *Obstet Gynecol* 68:741, 1986.
42. **Gotlieb WH, Beiner ME, Shalmon B, Korach Y, Segal Y, Zmira N, Koupolovic J, Ben-Baruch G**, Outcome of fertility-sparing treatment with progestins in young patients with endometrial cancer, *Obstet Gynecol* 102:718, 2003.
43. **Colafranceschi M, Taddei GL, Scarselli G, Branconi F, Tinacci G, Savino L**, Clinico-pathological profile of endometrial carcinoma in young women (under 40 years of age), *Eur J Gynaecol Oncol* 10:353, 1989.
44. **Gallup DG, Stock RJ**, Adenocarcinoma of the endometrium in women 40 years of age or younger, *Obstet Gynecol* 64:417, 1984.
45. **Giudice LC**, Endometrium in PCOS: implantation and predisposition to endocrine CA, *Best Pract Res Clin Endocrinol Metab* 20:235, 2006.
46. **Barry JA, Azizia MM, Hardiman PJ**, Risk of endometrial, ovarian and breast cancer in women with



- polycystic ovary syndrome: a systematic review and meta-analysis. *Hum Reprod Update* 20(5):748, 2014.
47. **Dragojevic S, Mitrovic A, Dikic S, Canovic F**, The role of transvaginal colour Doppler sonography in evaluation of abnormal uterine bleeding, *Arch Gynecol Obstet* 271:332, 2005.
  48. **Langer RD, Pierce JJ, O'Hanlan KA, Johnson SR, Espeland MA, Trabala JF, Barnabei VM, Merino MJ, Scully RE**, Transvaginal ultrasonography compared with endometrial biopsy for the detection of endometrial disease. *Postmenopausal Estrogen/Progestin Interventions Trial*, *N Engl J Med* 337:1792, 1997.
  49. **Fleischer AC, Wheeler JE, Lindsay I, Hendrix SL, Grabill S, Kravitz B, MacDonald B**, An assessment of the value of ultrasonographic screening for endometrial disease in postmenopausal women without symptoms, *Am J Obstet Gynecol* 184:70, 2001.
  50. **Moseson M, Koenig KL, Shore RE, Pasternack BS**, The influence of medical conditions associated with hormones on the risk of breast cancer, *Int J Epidemiol* 22:1000, 1993.
  51. **Terry KL, Willett WC, Rich-Edwards JW, Michels KB**, A prospective study of infertility due to ovulatory disorders, ovulation induction, and incidence of breast cancer, *Arch Intern Med* 166:2484, 2006.
  52. **Manuel M, Katayama KP, Jones HW Jr**, The age of occurrence of gonadal tumors in intersex patients with a Y chromosome, *Am J Obstet Gynecol* 124:293, 1976.
  53. **Troche V, Hernandez E**, Neoplasia arising in dysgenetic gonads, *Obstet Gynecol Surv* 41:74, 1986.
  54. **Davison RM, Quilter CR, Webb J, Murray A, Fisher AM, Valentine A, Serhal P, Conway GS**, A familial case of X chromosome deletion ascertained by cytogenetic screening of women with premature ovarian failure, *Hum Reprod* 13:3039, 1998.
  55. **Bione S, Sala C, Manzini C, Arrigo G, Zuffardi O, Banfi S, Borsani G, Jonveaux P, Philippe C, Zuccotti M, Ballabio A, Toniolo D**, A human homologue of the *Drosophila melanogaster* diaphanous gene is disrupted in a patient with premature ovarian failure: evidence for conserved function in oogenesis and implications for human sterility, *Am J Hum Genet* 62:533, 1998.
  56. **Davison RM, Fox M, Conway GS**, Mapping of the POF1 locus and identification of putative genes for premature ovarian failure, *Mol Hum Reprod* 6:314, 2000.
  57. **Prueitt RL, Ross JL, Zinn AR**, Physical mapping of nine Xq translocation breakpoints and identification of XPNPEP2 as a premature ovarian failure candidate gene, *Cytogenet Cell Genet* 89:44, 2000.
  58. **Wittenberger MD, Hagerman RJ, Sherman SL, McConkie-Rosell A, Welt CK, Rebar RW, Corrigan EC, Simpson JL, Nelson LM**, The FMR1 premutation and reproduction, *Fertil Steril* 87:456, 2007.
  59. **Sherman SL**, Premature ovarian failure in the fragile X syndrome, *Am J Med Genet* 97:189, 2000.
  60. **American College of Obstetricians and Gynecologists Committee on Genetics**, ACOG committee opinion no. 338: screening for fragile X syndrome, *Obstet Gynecol* 107:1483, 2006.
  61. **Welt CK**, Autoimmune oophoritis in the adolescent, *Ann N Y Acad Sci* 1135:118, 2008.
  62. **Hoek A, Schoemaker J, Drexhage HA**, Premature ovarian failure and ovarian autoimmunity, *Endocr Rev* 18:107, 1997.
  63. **Kim TJ, Anasti JN, Flack MR, Kimzey LM, Defensor RA, Nelson LM**, Routine endocrine screening for patients with karyotypically normal spontaneous premature ovarian failure, *Obstet Gynecol* 89:777, 1997.
  64. **Tommaselli AP, Valentino R, Savastano S, Randazzo G, Scalfi L, Contaldo F, Dorato M, Lombardi G**, Altered glycosylation of pituitary gonadotropins in anorexia nervosa: an alternative explanation for amenorrhea, *Eur J Endocrinol* 132:450, 1995.
  65. **Stein AL, Levenick MN, Kletzkly OA**, Computed tomography versus magnetic resonance imaging for the evaluation of suspected pituitary adenomas, *Obstet Gynecol* 73:996, 1989.
  66. **Behan LA, Phillips J, Thompson CJ, Agha A**, Neuroendocrine disorders after traumatic brain injury, *J Neurol Neurosurg Psychiatry* 79:753, 2008.
  67. **Bedecarrats GY, Kaiser UB**, Mutations in the human gonadotropin-releasing hormone receptor: insights into receptor biology and function, *Semin Reprod Med* 25:368, 2007.
  68. **Layman LC, McDonough PG, Cohen DP, Maddox M, Tho SP, Reindollar RH**, Familial gonadotropin-releasing hormone resistance and hypogonadotropic hypogonadism in a family with multiple affected individuals, *Fertil Steril* 75:1148, 2001.
  69. **Homburg R, Eshel A, Armar NA, Tucker M, Mason PW, Adams J, Kilborn J, Sutherland IA, Jacobs**

- HS, One hundred pregnancies after treatment with pulsatile luteinising hormone releasing hormone to induce ovulation, *Br Med J* 298:809, 1989.
70. **Martin KA, Hall JE, Adams JM, Crowley WF Jr**, Comparison of exogenous gonadotropins and pulsatile gonadotropin-releasing hormone for induction of ovulation in hypogonadotropic amenorrhea, *J Clin Endocrinol Metab* 77(1):125, 1993.
  71. **Lim YH, Ng SP, Jamil MA**, Imperforate hymen: report of an unusual familial occurrence, *J Obstet Gynaecol Res* 29:399, 2003.
  72. **Dane C, Dane B, Erginbas M, Cetin A**, Imperforate hymen—a rare cause of abdominal pain: two cases and review of the literature, *J Pediatr Adolesc Gynecol* 20:245, 2007.
  73. **Acar A, Balci O, Karatayli R, Capar M, Colakoglu MC**, The treatment of 65 women with imperforate hymen by a central incision and application of Foley catheter, *Br J Obstet Gynaecol* 114:1376, 2007.
  74. **Markham SM, Parmley TH, Murphy AA, Huggins GR, Rock JA**, Cervical agenesis combined with vaginal agenesis diagnosed by magnetic resonance imaging, *Fertil Steril* 48:143, 1987.
  75. **Reinhold C, Hricak H, Forstner R, Ascher SM, Bret PM, Meyer WR, Semelka RC**, Primary amenorrhea: evaluation with MR imaging, *Radiology* 203:383, 1997.
  76. **Polasek PM, Erickson LD, Stanhope CR**, Transverse vaginal septum associated with tubal atresia, *Mayo Clin Proc* 70:965, 1995.
  77. **Fujimoto VY, Miller JH, Klein NA, Soules MR**, Congenital cervical atresia: report of seven cases and review of the literature, *Am J Obstet Gynecol* 177:1419, 1997.
  78. **Deffarges JV, Haddad B, Musset R, Paniel BJ**, Utero-vaginal anastomosis in women with uterine cervix atresia: long-term follow-up and reproductive performance. A study of 18 cases, *Hum Reprod* 16:1722, 2001.
  79. **Acien P, Acien MI, Quereda F, Santoyo T**, Cervicovaginal agenesis: spontaneous gestation at term after previous reimplantation of the uterine corpus in a neovagina: case report, *Hum Reprod* 23:548, 2008.
  80. **Griffin JE, Edwards C, Ladden JD, Harrod MJ, Wilson JD**, Congenital absence of the vagina, *Ann Intern Med* 85:224, 1976.
  81. **Aittomäki K, Eroila H, Kajanoja P**, A population-based study of the incidence of müllerian aplasia in Finland, *Fertil Steril* 76:624, 2001.
  82. **Rall K, Eisenbeis S, Barresi G, Rückner D, Walter M, Poths S, Wallwiener D, Riess O, Bonin M, Brucker S**, Mayer-Rokitansky-Küster-Hauser syndrome discordance in monozygotic twins: matrix metalloproteinase 14, low-density lipoprotein receptor-related protein 10, extracellular matrix, and neoangiogenesis genes identified as candidate genes in a tissue-specific mosaicism, *Fertil Steril* 103(2):494, 2015.
  83. **Imbeaud S, Faure E, Lamarre I, Matéi MG, di Clemente N, Tizard R, Carre-Eusebe D, Belville C, Tragethon L, Tonkin C**, et al., Insensitivity to anti-müllerian hormone due to a mutation in the human anti-müllerian hormone receptor, *Nat Genet* 11:382, 1995.
  84. **Josso N, Belville C, di Clemente N, Picard JY**, AMH and AMH receptor defects in persistent Müllerian duct syndrome, *Hum Reprod Update* 11:351, 2005.
  85. **Zenteno JC, Carranza-Lira S, Kofman-Alfaro S**, Molecular analysis of the anti-Müllerian hormone, the anti-Müllerian hormone receptor, and galactose-1-phosphate uridyl transferase genes in patients with the Mayer-Rokitansky-Küster-Hauser syndrome, *Arch Gynecol Obstet* 269:270, 2004.
  86. **Cramer DW, Goldstein DP, Fraer C, Reichardt JKV**, Vaginal agenesis (Mayer-Rokitansky-Küster-Hauser syndrome) associated with the N314D mutation of galactose-1-phosphate uridyl transferase (GALT), *Mol Hum Reprod* 2:145, 1996.
  87. **Chen YT, Mattison DR, Feigenbaum L, Fukui H, Schulman JD**, Reduction in oocyte number following prenatal exposure to a diet high in galactose, *Science* 214:1145, 1981.
  88. **Behera M, Couchman G, Walmer D, Price TM**, Müllerian agenesis and thrombocytopenia absent radius syndrome: a case report and review of syndromes associated with Müllerian agenesis, *Obstet Gynecol Surv* 60:453, 2005.
  89. **Fedele L, Bianchi S, Frontino G, Ciappina N, Fontana E, Borruto F**, Laparoscopic findings and pelvic anatomy in Mayer-Rokitansky-Küster-Hauser syndrome, *Obstet Gynecol* 109:1111, 2007.

90. **Strubbe EH, Willemsen WN, Lemmens JA, Thijn CJ, Rolland R**, Mayer-Rokitansky-Kuster-Hauser syndrome: distinction between two forms based on excretory urographic, sonographic, and laparoscopic findings, *Am J Roentgenol* 160:331, 1993.
91. **Letterie GS, Wilson J, Miyazawa K**, Magnetic resonance imaging of müllerian tract abnormalities, *Fertil Steril* 50:365, 1988.
92. **Fedele L, Dorta M, Brioschi D, Giudici MN, Candiani GB**, Magnetic resonance imaging in Mayer-Rokitansky-Kuster-Hauser Syndrome, *Obstet Gynecol* 76:593, 1990.
93. **Economy KE, Barnewolt C, Laufer MR**, A comparison of MRI and laparoscopy in detecting pelvic structures in cases of vaginal agenesis, *J Pediatr Adolesc Gynecol* 15:101, 2002.
94. **Frank RT**, Formation of artificial vagina without operation, *Am J Obstet Gynecol* 35:1053, 1938.
95. **Wabrek AJ, Millard PR, Wilson WB Jr, Pion RJ**, Creation of a neovagina by the Frank nonoperative method, *Obstet Gynecol* 37:408, 1971.
96. **Costa EMF, Mendonca BB, Inácio M, Arnhold IJP, Silva FAQ, Lodovici O**, Management of ambiguous genitalia in pseudohermaphrodites: new perspectives on vaginal dilation, *Fertil Steril* 67:229, 1997.
97. **Ingram J**, The bicycle seat stool in the treatment of vaginal agenesis and stenosis: a preliminary report, *Am J Obstet Gynecol* 140:867, 1981.
98. **McIndoe AH, Banister JB**, An operation for the cure of congenital absence of the vagina, *J Obstet Gynaecol Br Empire* 45:490–494, 1938.
99. **Vecchietti G**, [Creation of an artificial vagina in Rokitansky-Kuster-Hauser syndrome], *Attual Ostet Ginecol* 11:131, 1965.
100. **Brucker SY, Gegusch M, Zubke W, Rall K, Gauwerky JF, Wallwiener D**, Neovagina creation in vaginal agenesis: development of a new laparoscopic Vecchietti-based procedure and optimized instruments in a prospective comparative interventional study in 101 patients, *Fertil Steril* 90:1940, 2008.
101. **Fedele L, Bianchi S, Frontino G, Fontana E, Restelli E, Bruni V**, The laparoscopic Vecchietti's modified technique in Rokitansky syndrome: anatomic, functional, and sexual long-term results, *Am J Obstet Gynecol* 198:377 e1, 2008.
102. **Batzer FR, Corson SL, Gocial B, Daly DC, Go K, English ME**, Genetic offspring in patients with vaginal agenesis: specific medical and legal issues, *Am J Obstet Gynecol* 167:1288, 1992.
103. **Beski S, Gorgy A, Venkat G, Craft IL, Edmonds K**, Gestational surrogacy: a feasible option for patients with Rokitansky syndrome, *Hum Reprod* 15:2326, 2000.
104. **Petrozza JC, Gray MR, Davis AJ, Reindollar RH**, Congenital absence of the uterus and vagina is not commonly transmitted as a dominant genetic trait: outcomes of surrogate pregnancies, *Fertil Steril* 67:387, 1997.
105. **Brännström M, Dahm Kähler P, Greite R, Mölne J, Díaz-García C, Tullius SG**, Uterus transplantation: a rapidly expanding field, *Transplantation* 102(4):569, 2017. doi:10.1097/TP.0000000000002035.
106. **Brännström M**, Womb transplants with live births: an update and the future, *Expert Opin Biol Ther* 17(9):1105, 2017.
107. **Griffin JE**, Androgen resistance—the clinical and molecular spectrum, *N Engl J Med* 326:611, 1992.
108. **Sultan C, Lumbroso S, Paris F, Jeandel C, Terouanne B, Belon C, Audran F, Poujol N, Georget V, Gobinet J, Jalaguier S, Auzou G, Nicolas JC**, Disorders of androgen action, *Semin Reprod Med* 20:217, 2002.
109. **Faienza MF, Giordani L, Delvecchio M, Cavallo L**, Clinical, endocrine, and molecular findings in 17beta-hydroxysteroid dehydrogenase type 3 deficiency, *J Endocrinol Invest* 31:85, 2008.
110. **Purves JT, Miles-Thomas J, Migeon C, Gearhart JP**, Complete androgen insensitivity: the role of the surgeon, *J Urol* 180:1716, 2008.
111. **Morris JM, Mahesh VB**, Further observations on the syndrome “testicular feminization,” *Am J Obstet Gynecol* 87:731, 1963.
112. **Rutgers JL, Scully RE**, The androgen insensitivity syndrome (testicular feminization): a clinicopathologic study of 43 cases, *Int J Gynecol Pathol* 10:126, 1991.
113. **Simpson JL**, Genetics of sexual differentiation, In: Rock JA, Carpenter SE, eds. *Pediatric and Adolescent Gynecology*, Raven Press, New York, 1992, p. 1.

114. **Gililand J, Cummings D, Hibbert ML, Crain T, Rozanski T**, Laparoscopic orchiectomy in a patient with complete androgen insensitivity, *J Laparoendosc Surg* 3:51, 1993.
115. **Alvarez NR, Lee TM, Solorzano CC**, Complete androgen insensitivity syndrome: the role of the endocrine surgeon, *Am Surg* 71:241, 2005.
116. **Martin-Hirsch PL, Kitchener H**, Interventions for preventing blood loss during the treatment of cervical intraepithelial neoplasia, *Cochrane Database Syst Rev* (2):CD001421, 2000.
117. **Dickey KW, Zreik TG, Hsia HC, Eschelman DJ, Keefe DL, Olive DL, Pollak JS, Rosenblatt M, Glickman MG**, Transvaginal uterine cervical dilation with fluoroscopic guidance: preliminary results in patients with infertility, *Radiology* 200(2):497, 1996.
118. **Tan Y, Bennett MJ**, Urinary catheter stent placement for treatment of cervical stenosis, *Aust N Z J Obstet Gynaecol* 47:406, 2007.
119. **Asherman JG**, Amenorrhoea traumatica (atretica), *J Obstet Gynaecol Br Emp* 55:23, 1948.
120. **Berman JM**, Intrauterine adhesions, *Semin Reprod Med* 26:349, 2008.
121. **Davies C, Gibson M, Holt EM, Torrie EPH**, Amenorrhoea secondary to endometrial ablation and Asherman's syndrome following uterine artery embolization, *Clin Radiol* 57:317, 2002.
122. **Sharma JB, Roy KK, Pushparaj M, Gupta N, Jain SK, Malhotra N, Mittal S**, Genital tuberculosis: an important cause of Asherman's syndrome in India, *Arch Gynecol Obstet* 277:37, 2008.
123. **Krolkowski A, Janowski K, Larsen JV**, Asherman syndrome caused by schistosomiasis, *Obstet Gynecol* 85:898, 1995.
124. **Soares SR, Barbosa dos Reis MM, Camargos AF**, Diagnostic accuracy of sonohysterography, transvaginal sonography, and hysterosalpingography in patients with uterine cavity diseases, *Fertil Steril* 73:406, 2000.
125. **Al-Inany H**, Intrauterine adhesions. An update, *Acta Obstet Gynecol Scand* 80:986, 2001.
126. **March CM**, Intrauterine adhesions, *Obstet Gynecol Clin North Am* 22:491, 1995.
127. **Valle RF, Sciarra JJ**, Intrauterine adhesions: hysteroscopic diagnosis, classification, treatment, and reproductive outcome, *Am J Obstet Gynecol* 158: 1459, 1988.
128. **Donnez J, Nisolle M**, Hysteroscopic surgery, *Curr Opin Obstet Gynecol* 4:439, 1992.
129. **American Society for Reproductive Medicine**, Classifications of adnexal adhesions, distal tubal occlusion, tubal occlusion secondary to tubal ligation, tubal pregnancies, müllerian anomalies and intrauterine adhesions, *Fertil Steril* 49:944, 1988.
130. **Nasr AL, Al-Inany HG, Thabet SM, Aboulghar M**, A clinicohysteroscopic scoring system of intrauterine adhesions, *Gynecol Obstet Invest* 50:178, 2000.
131. **Orhue AA, Aziken ME, Igbefoh JO**, A comparison of two adjunctive treatments for intrauterine adhesions following lysis, *Int J Gynaecol Obstet* 82:49, 2003.
132. **Yu D, Wong YM, Cheong Y, Xia E, Li TC**, Asherman syndrome—one century later, *Fertil Steril* 89:759, 2008.
133. **Fernandez H, Peyrelevade S, Legendre G, Faivre E, Deffieux X, Nazac A**, Total adhesions treated by hysteroscopy: must we stop at two procedures? *Fertil Steril* 98(4):980, 2012.
134. **Fernandez H, Al-Najjar F, Chauveaud-Lambling A, Frydman R, Gervaise A**, Fertility after treatment of Asherman's syndrome stage 3 and 4, *J Minim Invasive Gynecol* 13:398, 2006.
135. **Santamaria X, Cabanillas S, Cervelló I, Arbona C, Raga F, Ferro J, Palmero J, Remohí J, Pellicer A, Simón C**, Autologous cell therapy with CD133+ bone marrow-derived stem cells for refractory Asherman's syndrome and endometrial atrophy: a pilot cohort study, *Hum Reprod* 31(5):1087, 2016.
136. **Liu Y, Tal R, Pluchino N, Mamillapalli R, Taylor HS**, Systemic administration of bone marrow-derived cells leads to better uterine engraftment than use of uterine-derived cells or local injection, *J Cell Mol Med* 22(1):67, 2018. doi:10.1111/jcmm.13294.
137. **Sagi L, Zuckerman-Levin N, Gawlik A, Ghizzoni L, Buyukgebiz A, Rakover Y, Bistritzer T, Admoni O, Vottero A, Baruch O, Fares F, Malecka-Tendera E, Hochberg Z**, Clinical significance of the parental origin of the X chromosome in Turner syndrome, *J Clin Endocrinol Metab* 92:846, 2007.
138. **Gravholt CH, Fedder J, Naeraa RW, Müller J**, Occurrence of gonadoblastoma in females with Turner

syndrome and Y chromosome material: a population study, *J Clin Endocrinol Metab* 85:3199, 2000.

139. **Medlej R, Lobaccaro JM, Berta P, Belon C, Leheup B, Toubanc JE, Weill J, Chevalier C, Dumas R, Sultan C**, Screening for Y-derived sex determining gene SRY in 40 patients with Turner syndrome, *J Clin Endocrinol Metab* 75:1289, 1992.
140. **Saenger P, Wikland KA, Conway GS, Davenport M, Gravholt CH, Hintz R, Hovatta O, Hultcrantz M, Landin-Wilhelmsen K, Lin A, Lippe B, Pasquino AM, Ranke MB, Rosenfeld R, Silberbach M**, Recommendations for the diagnosis and management of Turner syndrome, *J Clin Endocrinol Metab* 86:3061, 2001.
141. **Pasquino AM, Passeri F, Pucarelli I, Segni M, Municchi G**, Spontaneous pubertal development in Turner's syndrome. Italian Study Group for Turner's Syndrome, *J Clin Endocrinol Metab* 82:1810, 1997.
142. **Elsheikh M, Wass JA, Conway GS**, Autoimmune thyroid syndrome in women with Turner's syndrome—the association with karyotype, *Clin Endocrinol (Oxf)* 55(2):223, 2001.
143. **Bonamico M, Pasquino AM, Mariani P, Danesi HM, Culasso F, Mazzanti L, Petri A, Bona G**, Prevalence and clinical picture of celiac disease in Turner syndrome, *J Clin Endocrinol Metab* 87:5495, 2002.
144. **Hjerrild BE, Mortensen KH, Gravholt CH**, Turner syndrome and clinical treatment, *Br Med Bull* 86:77, 2008.
145. **Bonnard Å, Hederstierna C, Bark R, Hultcrantz M**, Audiometric features in young adults with Turner syndrome, *Int J Audiol* 56(9):650, 2017.
146. **Gravholt CH**, Epidemiological, endocrine and metabolic features in Turner syndrome, *Eur J Endocrinol* 151:657, 2004.
147. **Russell HF, Wallis D, Mazzocco MM, Moshang T, Zackai E, Zinn AR, Ross JL, Muenke M**, Increased prevalence of ADHD in Turner syndrome with no evidence of imprinting effects, *J Pediatr Psychol* 31:945, 2006.
148. **Schoemaker MJ, Swerdlow AJ, Higgins CD, Wright AF, Jacobs PA**, Mortality in women with Turner syndrome in Great Britain: a national cohort study, *J Clin Endocrinol Metab* 93:4735, 2008.
149. **Schoemaker MJ, Swerdlow AJ, Higgins CD, Wright AF, Jacobs PA**, Cancer incidence in women with Turner syndrome in Great Britain: a national cohort study, *Lancet Oncol* 9:239, 2008.
150. **Practice Committee of American Society for Reproductive Medicine**, Increased maternal cardiovascular mortality associated with pregnancy in women with Turner syndrome, *Fertil Steril* 90:S185, 2008.
151. **Oktay K, Bedoschi G, Berkowitz K, Bronson R, Kashani B, McGovern P, Pal L, Quinn G, Rubin K**, Fertility preservation in women with Turner syndrome: a comprehensive review and practical guidelines, *J Pediatr Adolesc Gynecol* 29(5):409, 2016.
152. **Berkovitz GD, Fechner PY, Zacur HW, Rock JA, Snyder HM, Migeon CJ, Perlman EJ**, Clinical and pathologic spectrum of 46, XY gonadal dysgenesis: its relevance to the understanding of sex differentiation, *Medicine* 70:375, 1991.
153. **Sanchez-Moreno I, Canto P, Munguia P, de Leon MB, Cisneros B, Vilchis F, Reyes E, Mendez JP**, DNA binding activity studies and computational approach of mutant SRY in patients with 46, XY complete pure gonadal dysgenesis, *Mol Cell Endocrinol* 299:212, 2009.
154. **Assumpcao JG, Benedetti CE, Maciel-Guerra AT, Guerra G Jr, Baptista MT, Scolfaro MR, de Mello MP**, Novel mutations affecting SRY DNA-binding activity: the HMG box N65H associated with 46,XY pure gonadal dysgenesis and the familial non-HMG box R30I associated with variable phenotypes, *J Mol Med* 80:782, 2002.
155. **Canto P, Soderlund D, Reyes E, Mendez JP**, Mutations in the desert hedgehog (DHH) gene in patients with 46,XY complete pure gonadal dysgenesis, *J Clin Endocrinol Metab* 89:4480, 2004.
156. **Paris F, Philibert P, Lumbroso S, Baldet P, Charvet JP, Galifer RB, Sultan C**, Primary amenorrhea in a 46,XY adolescent girl with partial gonadal dysgenesis: identification of a new SRY gene mutation, *Fertil Steril* 88:1437 e21, 2007.
157. **Cools M, Stoop H, Kersemaekers AM, Drop SL, Wolffenbuttel KP, Bourguignon JP, Slowikowska-Hilczner J, Kula K, Faradz SM, Oosterhuis JW, Looijenga LH**, Gonadoblastoma arising in undifferentiated

- gonadal tissue within dysgenetic gonads, *J Clin Endocrinol Metab* 91:2404, 2006.
158. **Plante BJ, Fritz MA**, A case report of successful pregnancy in a patient with pure 46,XY gonadal dysgenesis, *Fertil Steril* 90:2015 e1, 2008.
  159. **Simpson JL**, Genetic and phenotypic heterogeneity in ovarian failure: overview of selected candidate genes, *Ann N Y Acad Sci* 1135:146, 2008.
  160. **Welt CK**, Primary ovarian insufficiency: a more accurate term for premature ovarian failure, *Clin Endocrinol (Oxf)* 68:499, 2008.
  161. **Taylor AE, Adams JM, Mulder JE, Martin KA, Sluss PM, Crowley WF Jr**, A randomized, controlled trial of estradiol replacement therapy in women with hypergonadotropic amenorrhea, *J Clin Endocrinol Metab* 81:3615, 1996.
  162. **van Kasteren YM, Schoemaker J**, Premature ovarian failure: a systematic review on therapeutic interventions to restore ovarian function and achieve pregnancy, *Hum Reprod Update* 5:483, 1999.
  163. **Luborsky JL, Meyer P, Sowers MF, Gold EB, Santoro N**, Premature menopause in a multi-ethnic population study of the menopause transition, *Hum Reprod* 18:199, 2003.
  164. **Rajangam S, Nanjappa L**, Cytogenetic studies in amenorrhea, *Saudi Med J* 28:187, 2007.
  165. **Massad-Costa AM, da Silva ID, Affonso R, Soares JM Jr, Nunes MG, de Lima GR, Baracat EC**, Gene analysis in patients with premature ovarian failure or gonadal dysgenesis: a preliminary study, *Maturitas* 57:399, 2007.
  166. **Pieretti M, Zhang FP, Fu YH, Warren ST, Oostra BA, Caskey CT, Nelson DL**, Absence of expression of the FMR-1 gene in fragile X syndrome, *Cell* 66:817, 1991.
  167. **Sobesky WE, Taylor AK, Pennington BF, Bennetto L, Porter D, Riddle J, Hagerman RJ**, Molecular/clinical correlations in females with fragile X, *Am J Med Genet* 64:340, 1996.
  168. **de Vries BB, Wiegers AM, Smits AP, Mohkamsing S, Duivenvoorden HJ, Fryns JP, Curfs LM, Halley DJ, Oostra BA, van den Ouweland AM, Niermeijer MF**, Mental status of females with an FMR1 gene full mutation, *Am J Hum Genet* 58:1025, 1996.
  169. **Bennetto L, Pennington BF, Porter D, Taylor AK, Hagerman RJ**, Profile of cognitive functioning in women with the fragile X mutation, *Neuropsychology* 15:290, 2001.
  170. **Jacquemont S, Hagerman RJ, Leehey M, Grigsby J, Zhang L, Brunberg JA, Greco C, Des Portes V, Jardini T, Levine R, Berry-Kravis E, Brown WT, Schaeffer S, Kissel J, Tassone F, Hagerman PJ**, Fragile X premutation tremor/ataxia syndrome: molecular, clinical, and neuroimaging correlates, *Am J Hum Genet* 72:869, 2003.
  171. **Berry-Kravis E, Potanos K, Weinberg D, Zhou L, Goetz CG**, Fragile X-associated tremor/ataxia syndrome in sisters related to X-inactivation, *Ann Neurol* 57:144, 2005.
  172. **Sullivan AK, Marcus M, Epstein MP, Allen EG, Anido AE, Paquin JJ, Yadav-Shah M, Sherman SL**, Association of FMR1 repeat size with ovarian dysfunction, *Hum Reprod* 20:402, 2005.
  173. **Ennis S, Ward D, Murray A**, Nonlinear association between CGG repeat number and age of menopause in FMR1 premutation carriers, *Eur J Hum Genet* 14:253, 2006.
  174. **Bodega B, Bione S, Dalpra L, Toniolo D, Ornaghi F, Vegetti W, Ginelli E, Marozzi A**, Influence of intermediate and uninterrupted FMR1 CGG expansions in premature ovarian failure manifestation, *Hum Reprod* 21:952, 2006.
  175. **Bretherick KL, Fluker MR, Robinson WP**, FMR1 repeat sizes in the gray zone and high end of the normal range are associated with premature ovarian failure, *Hum Genet* 117:376, 2005.
  176. **Welt CK, Smith PC, Taylor AE**, Evidence of early ovarian aging in fragile X premutation carriers, *J Clin Endocrinol Metab* 89:4569, 2004.
  177. **Rohr J, Allen EG, Charen K, Giles J, He W, Dominguez C, Sherman SL**, Anti-Mullerian hormone indicates early ovarian decline in fragile X mental retardation (FMR1) premutation carriers: a preliminary study. *Hum Reprod* 23(5):1220, 2008.
  178. **Nolin SL, Brown WT, Glicksman A, Houck GE Jr, Gargano AD, Sullivan A, Biancalana V, Brondum-Nielsen K, Hjalgrim H, Holinski-Feder E, Kooy F, Longshore J, Macpherson J, Mandel JL, Matthijs G, Rousseau F, Steinbach P, Vaisanen ML, von Koskull H, Sherman SL**, Expansion of the

- fragile X CGG repeat in females with premutation or intermediate alleles, *Am J Hum Genet* 72:454, 2003.
179. **McConkie-Rosell A, Finucane B, Cronister A, Abrams L, Bennett RL, Pettersen BJ**, Genetic counseling for fragile X syndrome: updated recommendations of the national society of genetic counselors, *J Genet Couns* 14:249, 2005.
  180. **Sherman S, Pletcher BA, Driscoll DA**, Fragile X syndrome: diagnostic and carrier testing, *Genet Med* 7:584, 2005.
  181. **Karimov CB, Moragianni VA, Cronister A, Srouji S, Petrozza J, Racowsky C, Ginsburg E, Thornton KL, Welt CK**, Increased frequency of occult fragile X-associated primary ovarian insufficiency in infertile women with evidence of impaired ovarian function. *Hum Reprod* 26(8):2077, 2011.
  182. **Bakalov VK, Anasti JN, Calis KA, Vanderhoof VH, Premkumar A, Chen S, Furmaniak J, Smith BR, Merino MJ, Nelson LM**, Autoimmune oophoritis as a mechanism of follicular dysfunction in women with 46,XX spontaneous premature ovarian failure, *Fertil Steril* 84:958, 2005.
  183. **Kalantaridou SN, Braddock DT, Patronas NJ, Nelson LM**, Treatment of autoimmune premature ovarian failure, *Hum Reprod* 14:1777, 1999.
  184. **Welt CK, Falorni A, Taylor AE, Martin KA, Hall JE**, Selective theca cell dysfunction in autoimmune oophoritis results in multifollicular development, decreased estradiol, and elevated inhibin B levels, *J Clin Endocrinol Metab* 90:3069, 2005.
  185. **Novosad JA, Kalantaridou SN, Tong Z-B, Nelson LM**, Ovarian antibodies as detected by indirect immunofluorescence are unreliable in the diagnosis of autoimmune premature ovarian failure: a controlled evaluation, *BMC Women's Health* 3:2, 2003.
  186. **Anasti JN, Flack MR, Froehlich J, Nelson LM**, The use of human recombinant gonadotropin receptors to search for immunoglobulin G-mediated premature ovarian failure, *J Clin Endocrinol Metab* 80:824, 1995.
  187. **Lo Presti A, Ruvolo G, Gancitano RA, Cittadini E**, Ovarian function following radiation and chemotherapy for cancer, *Eur J Obstet Gynecol Reprod Biol* 113(Suppl 1):S33, 2004.
  188. **Raymond JP, Izembart M, Marliac V, Dagousset F, Merceron RE, Vulpillat M, Vallee G**, Temporary ovarian failure in thyroid cancer patients after thyroid remnant ablation with radioactive iodine, *J Clin Endocrinol Metab* 69: 186, 1989.
  189. **Asch P**, The influence of radiation on fertility in man, *Br J Radiol* 53:271, 1980.
  190. **Wallace WH, Thomson AB, Kelsey TW**, The radiosensitivity of the human oocyte, *Hum Reprod* 18:117, 2003.
  191. **Faddy MJ, Gosden RG**, A model conforming the decline in follicle numbers to the age of menopause in women, *Hum Reprod* 11:1484, 1996.
  192. **Wallace WH, Thomson AB, Saran F, Kelsey TW**, Predicting age of ovarian failure after radiation to a field that includes the ovaries, *Int J Radiat Oncol Biol Phys* 62:738, 2005.
  193. **Madsen BL, Giudice L, Donaldson SS**, Radiation-induced premature menopause: a misconception, *Int J Radiat Oncol Biol Phys* 32:1461, 1995.
  194. **Stillman RJ, Schinfeld JS, Schiff I, Gelber RD, Greenberger J, Larson M, Jaffe N, Li FP**, Ovarian failure in long-term survivors of childhood malignancy, *Am J Obstet Gynecol* 139:62, 1981.
  195. **Morice P, Thiam-Ba R, Castaigne D, Haie-Meder C, Gerbaulet A, Pautier P, Duvillard P, Michel G**, Fertility results after ovarian transposition for pelvic malignancies treated by external irradiation or brachytherapy, *Hum Reprod* 13:660, 1998.
  196. **Sonmezer M, Oktay K**, Fertility preservation in female patients, *Hum Reprod Update* 10:251, 2004.
  197. **Averette HE, Boike GM, Jarrell MA**, Effects of cancer chemotherapy on gonadal function and reproductive capacity, *CA Cancer J Clin* 40:199, 1990.
  198. **Critchley HO, Bath LE, Wallace WH**, Radiation damage to the uterus—review of the effects of treatment of childhood cancer, *Hum Fertil (Camb)* 5:61, 2002.
  199. **Green DM, Peabody EM, Nan B, Peterson S, Kalapurakal JA, Breslow NE**, Pregnancy outcome after treatment for Wilms tumor: a report from the National Wilms Tumor Study Group, *J Clin Oncol* 20:2506, 2002.
  200. **Green DM, Whitton JA, Stovall M, Mertens AC, Donaldson SS, Ruymann FB, Pendergrass TW, Robison LL**, Pregnancy outcome of female survivors of childhood cancer: a report from the Childhood

Cancer Survivor Study, *Am J Obstet Gynecol* 187:1070, 2002.

201. **Koyama H, Wada T, Nishizawa Y, Iwanaga T, Aoki Y**, Cyclophosphamide-induced ovarian failure and its therapeutic significance in patients with breast cancer, *Cancer* 39:1403, 1977.
202. **Iwase A, Nakamura T, Nakahara T, Goto M, Kikkawa F**, Anti-Müllerian hormone and assessment of ovarian reserve after ovarian toxic treatment: a systematic narrative review, *Reprod Sci* 22(5):519, 2015. doi:10.1177/1933719114549856.
203. **Su HI, Sammel MD, Green J, Velders L, Stankiewicz C, Matro J, Freeman EW, Gracia CR, DeMichele A**, Antimüllerian hormone and inhibin B are hormone measures of ovarian function in late reproductive-aged breast cancer survivors, *Cancer* 116(3):592, 2010.
204. **Practice Committee of American Society for Reproductive Medicine**, The menopausal transition, *Fertil Steril* 90:S61, 2008.
205. **Bath LE, Wallace WH, Shaw MP, Fitzpatrick C, Anderson RA**, Depletion of ovarian reserve in young women after treatment for cancer in childhood: detection by anti-Müllerian hormone, inhibin B and ovarian ultrasound, *Hum Reprod* 18:2368, 2003.
206. **Larsen EC, Muller J, Rechnitzer C, Schmiegelow K, Andersen AN**, Diminished ovarian reserve in female childhood cancer survivors with regular menstrual cycles and basal FSH < 10 IU/L, *Hum Reprod* 18:417, 2003.
207. **Anderson RA, Themmen AP, Al-Qahtani A, Groome NP, Cameron DA**, The effects of chemotherapy and long-term gonadotrophin suppression on the ovarian reserve in premenopausal women with breast cancer, *Hum Reprod* 21: 2583, 2006.
208. **Ataya K, Rao LV, Lawrence E, Kimmel R**, Luteinizing hormone-releasing hormone agonist inhibits cyclophosphamide-induced ovarian follicular depletion in Rhesus monkeys, *Biol Reprod* 52:365, 1995.
209. **Blumenfeld Z**, How to preserve fertility in young women exposed to chemotherapy? The role of GnRH agonist cotreatment in addition to cryopreservation of embryos, oocytes, or ovaries, *Oncologist* 12:1044, 2007.
210. **Munhoz RR, Pereira AA, Sasse AD, Hoff PM, Traina TA, Hudis CA, Marques RJ**, Gonadotropin-releasing hormone agonists for ovarian function preservation in premenopausal women undergoing chemotherapy for early-stage breast cancer: a systematic review and meta-analysis. *JAMA Oncol* 2(1):65, 2016.
211. **Senra JC, Roque M, Talim MCT, Reis FM, Tavares RLC**, Gonadotropin-releasing hormone agonists for ovarian protection during cancer chemotherapy: systematic review and meta-analysis, *Ultrasound Obstet Gynecol* 51(1):77, 2017. doi:10.1002/uog.18934.
212. **Cuzick J, Ambroisine L, Davidson N, Jakesz R, Kaufmann M, Regan M, Sainsbury R**, Use of luteinising-hormone-releasing hormone agonists as adjuvant treatment in premenopausal patients with hormone-receptor-positive breast cancer: a meta-analysis of individual patient data from randomised adjuvant trials, *Lancet* 369:1711, 2007.
213. **Schmidt KL, Andersen CY, Loft A, Byskov AG, Ernst E, Andersen AN**, Follow-up of ovarian function post-chemotherapy following ovarian cryopreservation and transplantation, *Hum Reprod* 20:3539, 2005.
214. **Oktay K, Sonmezer M, Oktem O, Fox K, Emons G, Bang H**, Absence of conclusive evidence for the safety and efficacy of gonadotropin-releasing hormone analogue treatment in protecting against chemotherapy-induced gonadal injury, *Oncologist* 12:1055, 2007.
215. **Waxman JH, Ahmed R, Smith D, Wrigley PF, Gregory W, Shalet S, Crowther D, Rees LH, Besser GM, Malpas JS, et al.**, Failure to preserve fertility in patients with Hodgkin's disease, *Cancer Chemother Pharmacol* 19:159, 1987.
216. **Emons G, Grundker C, Gunthert AR, Westphalen S, Kavanagh J, Verschraegen C**, GnRH antagonists in the treatment of gynecological and breast cancers, *Endocr Relat Cancer* 10:291, 2003.
217. **Goldhirsch A, Glick JH, Gelber RD, Coates AS, Thurlimann B, Senn HJ**, Meeting highlights: international expert consensus on the primary therapy of early breast cancer 2005, *Ann Oncol* 16:1569, 2005.
218. **Cheng CK, Leung PC**, Molecular biology of gonadotropin-releasing hormone (GnRH)-I, GnRH-II, and their receptors in humans, *Endocr Rev* 26:283, 2005.
219. **Vitale AM, Abramovich D, Peluffo MC, Meresman G, Tesone M**, Effect of gonadotropin-releasing



- hormone agonist and antagonist on proliferation and apoptosis of human luteinized granulosa cells, *Fertil Steril* 85:1064, 2006.
220. **Levy HL, Driscoll SG, Porensky RS, Wender DF**, Ovarian failure in galactosemia, *N Engl J Med* 310:50, 1984.
  221. **Robinson AC, Dockeray CJ, Cullen MJ, Sweeney EC**, Hypergonadotrophic hypogonadism in classical galactosaemia: evidence for defective oogenesis. Case report, *Br J Obstet Gynaecol* 91:199, 1984.
  222. **Guerrero NV, Singh RH, Manatunga A, Berry GT, Steiner RD, Elsas LJ**, Risk factors for premature ovarian failure in females with galactosemia, *J Pediatr* 137:833, 2000.
  223. **Jones GS, De Moraes-Ruehsen M**, A new syndrome of amenorrhea in association with hypergonadotropism and apparently normal ovarian follicular apparatus, *Am J Obstet Gynecol* 104:597, 1969.
  224. **Di Pasquale E, Beck-Peccoz P, Persani L**, Hypergonadotropic ovarian failure associated with an inherited mutation of human bone morphogenetic protein-15 (BMP15) gene, *Am J Hum Genet* 75:106, 2004.
  225. **Di Pasquale E, Rossetti R, Marozzi A, Bodega B, Borgato S, Cavallo L, Einaudi S, Radetti G, Russo G, Sacco M, Wasniewska M, Cole T, Beck-Peccoz P, Nelson LM, Persani L**, Identification of new variants of human BMP15 gene in a large cohort of women with premature ovarian failure, *J Clin Endocrinol Metab* 91:1976, 2006.
  226. **Uhlenhaut NH, Treier M**, Foxl2 function in ovarian development, *Mol Genet Metab* 88:225, 2006.
  227. **Lin D, Sugawara T, Strauss JF III, Clark BJ, Stocco DM, Saenger P, Rogol A, Miller WL**, Role of steroidogenic acute regulatory protein in adrenal and gonadal steroidogenesis, *Science* 267:1828, 1995.
  228. **Tian Q, Zhang Y, Lu Z**, Partial 17alpha-hydroxylase/17,20-lyase deficiency-clinical report of five Chinese 46,XX cases, *Gynecol Endocrinol* 24:362, 2008.
  229. **Lin L, Ercan O, Raza J, Burren CP, Creighton SM, Auchus RJ, Dattani MT, Achermann JC**, Variable phenotypes associated with aromatase (CYP19) insufficiency in humans, *J Clin Endocrinol Metab* 92:982, 2007.
  230. **Weiss J, Axelrod L, Whitcomb RW, Harris PE, Crowley WF, Jameson JL**, Hypogonadism caused by a single amino acid substitution in the beta subunit of luteinizing hormone, *N Engl J Med* 326:179, 1992.
  231. **Matthews CH, Borgato S, Beck-Peccoz P, Adams M, Tone Y, Gambino G, Casagrande S, Tedeschini G, Benedetti A, Chatterjee VK**, Primary amenorrhoea and infertility due to a mutation in the beta-subunit of follicle-stimulating hormone, *Nat Genet* 5:83, 1993.
  232. **Lussiana C, Guani B, Mari C, Restagno G, Massobrio M, Revelli A**, Mutations and polymorphisms of the FSH receptor (FSHR) gene: clinical implications in female fecundity and molecular biology of FSHR protein and gene, *Obstet Gynecol Surv* 63:785, 2008.
  233. **Aittomaki K**, The genetics of XX gonadal dysgenesis, *Am J Hum Genet* 54: 844, 1994.
  234. **Aittomaki K, Lucena JL, Pakarinen P, Sistonen P, Tapanainen J, Gromoll J, Kaskikari R, Sankila EM, Lehvaslaiho H, Engel AR, Nieschlag E, Huhtaniemi I, de la Chapelle A**, Mutation in the follicle-stimulating hormone receptor gene causes hereditary hypergonadotropic ovarian failure, *Cell* 82:959, 1995.
  235. **Layman LC, Amde S, Cohen DP, Jin M, Xie J**, The Finnish follicle-stimulating hormone receptor gene mutation is rare in North American women with 46,XX ovarian failure, *Fertil Steril* 69:300, 1998.
  236. **da Fonte Kohek MB, Batista MC, Russell AJ, Vass K, Giacaglia LR, Mendonca BB, Latronico AC**, No evidence of the inactivating mutation (C566T) in the follicle-stimulating hormone receptor gene in Brazilian women with premature ovarian failure, *Fertil Steril* 70:565, 1998.
  237. **Jiang M, Aittomaki K, Nilsson C, Pakarinen P, Iitia A, Torresani T, Simonsen H, Goh V, Pettersson K, de la Chapelle A, Huhtaniemi I**, The frequency of an inactivating point mutation (566C->T) of the human follicle-stimulating hormone receptor gene in four populations using allele-specific hybridization and time-resolved fluorometry, *J Clin Endocrinol Metab* 83:4338, 1998.
  238. **Takakura K, Takebayashi K, Wang HQ, Kimura F, Kasahara K, Noda Y**, Follicle-stimulating hormone receptor gene mutations are rare in Japanese women with premature ovarian failure and polycystic ovary syndrome, *Fertil Steril* 75:207, 2001.
  239. **Doherty E, Pakarinen P, Tiitinen A, Kiilavuori A, Huhtaniemi I, Forrest S, Aittomaki K**, A novel mutation in the FSH receptor inhibiting signal transduction and causing primary ovarian failure, *J Clin*

Endocrinol Metab 87:1151, 2002.

240. **Allen LA, Achermann JC, Pakarinen P, Kotlar TJ, Huhtaniemi IT, Jameson JL, Cheetham TD, Ball SG**, A novel loss of function mutation in exon 10 of the FSH receptor gene causing hypergonadotrophic hypogonadism: clinical and molecular characteristics, *Hum Reprod* 18:251, 2003.
241. **Toledo SP, Brunner HG, Kraaij R, Post M, Dahia PL, Hayashida CY, Kremer HTAP**, An inactivating mutation of the luteinizing hormone receptor causes amenorrhea in a 46,XX female, *J Clin Endocrinol Metab* 81:3850, 1996.
242. **Latronico AC**, Naturally occurring mutations of the luteinizing hormone receptor gene affecting reproduction, *Semin Reprod Med* 18:17, 2000.
243. **Groff AA, Covington SN, Halverson LR, Fitzgerald OR, Vanderhoof V, Calis K, Nelson LM**, Assessing the emotional needs of women with spontaneous premature ovarian failure, *Fertil Steril* 83:1734, 2005.
244. **Anasti JN, Kalantaridou SN, Kimzey LM, Defensor RA, Nelson LM**, Bone loss in young women with karyotypically normal spontaneous premature ovarian failure, *Obstet Gynecol* 91:12, 1998.
245. **Kurtoglu-Aksoy N, Akhan SE, Bastu E, Gungor-Ugurlucan F, Telci A, Iyibozkurt AC, Topuz S**, Implications of premature ovarian failure on bone turnover markers and bone mineral density, *Clin Exp Obstet Gynecol* 41(2):149, 2014.
246. **Popat VB, Calis KA, Kalantaridou SN, Vanderhoof VH, Koziol D, Troendle JF, Reynolds JC, Nelson LM**, Bone mineral density in young women with primary ovarian insufficiency: results of a three-year randomized controlled trial of physiological transdermal estradiol and testosterone replacement, *J Clin Endocrinol Metab* 99(9):3418, 2014.
247. **Wellons M**, Cardiovascular disease and primary ovarian insufficiency, *Semin Reprod Med* 29(4):328, 2011.
248. **Atsma F, Bartelink ML, Grobbee DE, van der Schouw YT**, Postmenopausal status and early menopause as independent risk factors for cardiovascular disease: a meta-analysis, *Menopause* 13:265, 2006.
249. **Kalantaridou SN, Naka KK, Papanikolaou E, Kazakos N, Kravariti M, Calis KA, Paraskevaidis EA, Sideris DA, Tsatsoulis A, Chrousos GP, Michalis LK**, Impaired endothelial function in young women with premature ovarian failure: normalization with hormone therapy, *J Clin Endocrinol Metab* 89:3907, 2004.
250. **Mondul AM, Rodriguez C, Jacobs EJ, Calle EE**, Age at natural menopause and cause-specific mortality, *Am J Epidemiol* 162:1089, 2005.
251. **Ostberg JE, Storry C, Donald AE, Attar MJ, Halcox JP, Conway GS**, A dose-response study of hormone replacement in young hypogonadal women: effects on intima media thickness and metabolism, *Clin Endocrinol (Oxf)* 66:557, 2007.
252. **Chetkowski RJ, Meldrum DR, Steingold KA, Randle D, Lu JK, Eggena P, Hershman JM, Alkjaersig NK, Fletcher AP, Judd HL**, Biologic effects of transdermal estradiol, *N Engl J Med* 314:1615, 1986.
253. **Committee Opinion No. 698 Summary: hormone therapy in primary ovarian insufficiency**, *Obstet Gynecol* 129(5):963, 2017.
254. **Vujovic S, Brincat M, Erel T, Gambacciani M, Lambrinoudaki I, Moen MH, Schenck-Gustafsson K, Tremollieres F, Rozenberg S, Rees M; European Menopause and Andropause Society**, EMAS position statement: managing women with premature ovarian failure, *Maturitas* 67(1):91, 2010.
255. **Sullivan SD, Sarrel PM, Nelson LM**, Hormone replacement therapy in young women with primary ovarian insufficiency and early menopause, *Fertil Steril* 106(7):1588, 2016.
256. **The Writing Group for the PEPI Trial**, Effects of hormone replacement therapy on endometrial histology in postmenopausal women: the Postmenopausal Estrogen/Progestin Interventions (PEPI) Trial, *JAMA* 275:370, 1996.
257. **Crofton PM, Evans N, Bath LE, Warner P, Whitehead TJ, Critchley HO, Kelnar CJ, Wallace WH**, Physiological versus standard sex steroid replacement in young women with premature ovarian failure: effects on bone mass acquisition and turnover, *Clin Endocrinol (Oxf)* 73(6):707, 2010.
258. **Bernardi F, Hartmann B, Casarosa E, Luisi S, Stomati M, Fadalti M, Florio P, Santuz M, Luisi M, Petraglia F, Genazzani AR**, High levels of serum allopregnanolone in women with premature ovarian failure,

Gynecol Endocrinol 12:339, 1998.

259. **van der Stege JG, Groen H, van Zadelhoff SJ, Lambalk CB, Braat DD, van Kasteren YM, van Santbrink EJ, Apperloo MJ, Weijmar Schultz WC, Hoek A**, Decreased androgen concentrations and diminished general and sexual well-being in women with premature ovarian failure, *Menopause* 15(1):23, 2008.
260. **Elias AN, Pandian MR, Rojas FJ**, Serum levels of androstenedione, testosterone and dehydroepiandrosterone sulfate in patients with premature ovarian failure to age-matched menstruating controls, *Gynecol Obstet Invest* 43(1):47, 1997.
261. **Wierman ME, Basson R, Davis SR, Khosla S, Miller KK, Rosner W, Santoro N**, Androgen therapy in women: an Endocrine Society Clinical Practice guideline, *J Clin Endocrinol Metab* 91:3697, 2006.
262. **Nelson LM, Anasti JN, Kimzey LM, Defensor RA, Lipetz KJ, White BJ, Shawker TH, Merino MJ**, Development of luteinized graafian follicles in patients with karyotypically normal spontaneous premature ovarian failure, *J Clin Endocrinol Metab* 79:1470, 1994.
263. **Tartagni M, Cicinelli E, De Pergola G, De Salvia MA, Lavopa C, Loverro G**, Effects of pretreatment with estrogens on ovarian stimulation with gonadotropins in women with premature ovarian failure: a randomized, placebo-controlled trial, *Fertil Steril* 87:858, 2007.
264. **Surrey ES, Cedars MI**, The effect of gonadotropin suppression on the induction of ovulation in premature ovarian failure patients, *Fertil Steril* 52:36, 1989.
265. **Check JH, Nowroozi K, Chase JS, Nazari A, Shapse D, Vaze M**, Ovulation induction and pregnancies in 100 consecutive women with hypergonadotropic amenorrhea, *Fertil Steril* 53:811, 1990.
266. **Badawy A, Goda H, Ragab A**, Induction of ovulation in idiopathic premature ovarian failure: a randomized double-blind trial, *Reprod Biomed Online* 15:215, 2007.
267. **Sauer MV, Kavic SM**, Oocyte and embryo donation 2006: reviewing two decades of innovation and controversy, *Reprod Biomed Online* 12:153, 2006.
268. **Johnson J, Canning J, Kaneko T, Pru JK, Tilly JL**, Germline stem cells and follicular renewal in the postnatal mammalian ovary, *Nature* 428:145, 2004.
269. **Silvestris E, D'Oronzo S, Cafforio P, D'Amato G, Loverro G**, Perspective in infertility: the ovarian stem cells, *J Ovarian Res* 8:55, 2015.
270. **Zhai J, Yao G, Dong F, Bu Z, Cheng Y, Sato Y, Hu L, Zhang Y, Wang J, Dai S, Li J, Sun J, Hsueh AJ, Kawamura K, Sun Y**, In vitro activation of follicles and fresh tissue auto-transplantation in primary ovarian insufficiency patients, *J Clin Endocrinol Metab* 101(11):4405, 2016.
271. **Orshan SA, Furniss KK, Forst C, Santoro N**, The lived experience of premature ovarian failure, *J Obstet Gynecol Neonatal Nurs* 30:202, 2001.
272. **Freda PU, Wardlaw SL, Post KD**, Unusual causes of sellar/parasellar masses in a large transsphenoidal surgical series, *J Clin Endocrinol Metab* 81:3455, 1996.
273. **Saeger W**, Tumor-like lesions of the pituitary and sellar region, *Endocrinologist* 12:300, 2002.
274. **Alexander JM, Biller BM, Bikkal H, Zervas NT, Arnold A, Klibanski A**, Clinically nonfunctioning pituitary tumors are monoclonal in origin, *J Clin Invest* 86:336, 1990.
275. **Herman V, Fagin J, Gonsky R, Kovacs K, Melmed S**, Clonal origin of pituitary adenomas, *J Clin Endocrinol Metab* 71:1427, 1990.
276. **Verges B, Boureille F, Goudet P, Murat A, Beckers A, Sassolas G, Cougard P, Chambe B, Montvernay C, Calender A**, Pituitary disease in MEN type 1 (MEN1): data from the France-Belgium MEN1 multicenter study, *J Clin Endocrinol Metab* 87:457, 2002.
277. **Landis CA, Masters SB, Spada A, Pace AM, Bourne HR, Vallar L**, GTPase inhibiting mutations activate the alpha chain of Gs and stimulate adenylyl cyclase in human pituitary tumours, *Nature* 340:692, 1989.
278. **Vlotides G, Eigler T, Melmed S**, Pituitary tumor-transforming gene: physiology and implications for tumorigenesis, *Endocr Rev* 28:165, 2007.
279. **Binnerts A, Deurenberg P, Swart GR, Wilson JH, Lamberts SW**, Body composition in growth hormone-deficient adults, *Am J Clin Nutr* 55:918, 1992.
280. **Rosen T, Bosaeus I, Tolli J, Lindstedt G, Bengtsson BA**, Increased body fat mass and decreased extracellular fluid volume in adults with growth hormone deficiency, *Clin Endocrinol (Oxf)* 38:63, 1993.

281. **Holmes SJ, Economou G, Whitehouse RW, Adams JE, Shalet SM**, Reduced bone mineral density in patients with adult onset growth hormone deficiency, *J Clin Endocrinol Metab* 78:669, 1994.
282. **Rosen T, Bengtsson BA**, Premature mortality due to cardiovascular disease in hypopituitarism, *Lancet* 336:285, 1990.
283. **Rosen T, Wiren L, Wilhelmsen L, Wiklund I, Bengtsson BA**, Decreased psychological well-being in adult patients with growth hormone deficiency, *Clin Endocrinol (Oxf)* 40:111, 1994.
284. **Socin HV, Chanson P, Delemer B, Tabarin A, Rohmer V, Mockel J, Stevenaert A, Beckers A**, The changing spectrum of TSH-secreting pituitary adenomas: diagnosis and management in 43 patients, *Eur J Endocrinol* 148:433, 2003.
285. **Biller BM, Samuels MH, Zagar A, Cook DM, Arafah BM, Bonert V, Stavrou S, Kleinberg DL, Chipman JJ, Hartman ML**, Sensitivity and specificity of six tests for the diagnosis of adult GH deficiency, *J Clin Endocrinol Metab* 87:2067, 2002.
286. **Melmed S**, Medical progress: acromegaly, *N Engl J Med* 355:2558, 2006.
287. **Nieman LK, Biller BM, Findling JW, Newell-Price J, Savage MO, Stewart PM, Montori VM**, The diagnosis of Cushing's syndrome: an Endocrine Society Clinical Practice Guideline, *J Clin Endocrinol Metab* 93:1526, 2008.
288. **Comtois R, Bouchard J, Robert F**, Hypersecretion of gonadotropins by a pituitary adenoma: pituitary dynamic studies and treatment with bromocriptine in one patient, *Fertil Steril* 52:569, 1989.
289. **Katznelson L, Alexander JM, Bikkal HA, Jameson JL, Hsu DW, Klibanski A**, Imbalanced follicle-stimulating hormone—subunit hormone biosynthesis in human pituitary adenomas, *J Clin Endocrinol Metab* 74:1343, 1992.
290. **Katznelson L, Alexander JM, Klibanski A**, Clinically nonfunctioning pituitary adenomas, *J Clin Endocrinol Metab* 76:1089, 1993.
291. **Djerassi A, Coutifaris C, West VA, Asa SL, Kapoor SC, Pavlou SN, Snyder PJ**, Gonadotroph adenoma in a premenopausal woman secreting follicle-stimulating hormone and causing ovarian hyperstimulation, *J Clin Endocrinol Metab* 80:591, 1995.
292. **Castelbaum AJ, Bigdeli H, Post KD, Freedman MF, Snyder PJ**, Exacerbation of ovarian hyperstimulation by leuprolide reveals a gonadotroph adenoma, *Fertil Steril* 78:1311, 2002.
293. **Murata Y, Ando H, Nagasaka T, Takahashi I, Saito K, Fukugaki H, Matsuzawa K, Mizutani S**, Successful pregnancy after bromocriptine therapy in an anovulatory women complicated with ovarian hyperstimulation caused by follicle-stimulating hormone-producing plurihomonal pituitary microadenoma, *J Clin Endocrinol Metab* 88:1988, 2003.
294. **Tashiro H, Katabuchi H, Ohtake H, Kaku T, Ushio Y, Okamura H**, A follicle-stimulating hormone-secreting gonadotroph adenoma with ovarian enlargement in a 10-year-old girl, *Fertil Steril* 72:158, 1999.
295. **Daneshdoost L, Gennarelli TA, Bashey HM, Savino PJ, Sergott RC, Bosley TM, Snyder PJ**, Recognition of gonadotroph adenomas in women, *N Engl J Med* 324:589, 1991.
296. **Chaidarun SS, Klibanski A**, Gonadotropinomas, *Semin Reprod Med* 20: 339, 2002.
297. **Christin-Maitre S, Rongieres-Bertrand C, Kottler ML, Lahlou N, Frydman R, Touraine P, Bouchard P**, A spontaneous and severe hyperstimulation of the ovaries revealing a gonadotroph adenoma, *J Clin Endocrinol Metab* 83:3450, 1998.
298. **Valimaki MJ, Tiitinen A, Alfthan H, Paetau A, Poranen A, Sane T, Stenman UH**, Ovarian hyperstimulation caused by gonadotroph adenoma secreting follicle-stimulating hormone in 28-year-old woman, *J Clin Endocrinol Metab* 84:4204, 1999.
299. **Mor E, Rodi IA, Bayrak A, Paulson RJ, Sokol RZ**, Diagnosis of pituitary gonadotroph adenomas in reproductive-aged women, *Fertil Steril* 84:757, 2005.
300. **Webb SM, Rigla M, Wagner A, Oliver B, Bartumeus F**, Recovery of hypopituitarism after neurosurgical treatment of pituitary adenomas, *J Clin Endocrinol Metab* 84:3696, 1999.
301. **Beck-Peccoz P, Brucker-Davis F, Persani L, Smallridge RC, Weintraub BD**, Thyrotropin-secreting pituitary tumors, *Endocr Rev* 17:610, 1996.
302. **Freda PU, Post KD, Powell JS, Wardlaw SL**, Evaluation of disease status with sensitive measures of

- growth hormone secretion in 60 postoperative patients with acromegaly, *J Clin Endocrinol Metab* 83:3808, 1998.
303. **Fahlbusch R, Honegger J, Buchfelder M**, Surgical management of acromegaly, *Endocrinol Metab Clin North Am* 21:669, 1992.
  304. **Freda PU, Wardlaw SL, Post KD**, Long-term endocrinological follow-up evaluation in 115 patients who underwent transsphenoidal surgery for acromegaly, *J Neurosurg* 89:353, 1998.
  305. **Weber SL**, Cushing's syndrome attributable to topical use of lotrisone, *Endocr Pract* 3:140, 1997.
  306. **Nutting CM, Page SR**, Iatrogenic Cushing's syndrome due to nasal betamethasone: a problem not to be sniffed at!, *Postgrad Med J* 71:231, 1995.
  307. **Hughes JM, Hichens M, Booze GW, Thorner MO**, Cushing's syndrome from the therapeutic use of intramuscular dexamethasone acetate, *Arch Intern Med* 146:1848, 1986.
  308. **Lado-Abeal J, Rodriguez-Arnao J, Newell-Price JD, Perry LA, Grossman AB, Besser GM, Trainer PJ**, Menstrual abnormalities in women with Cushing's disease are correlated with hypercortisolemia rather than raised circulating androgen levels, *J Clin Endocrinol Metab* 83:3083, 1998.
  309. **Elamin MB, Murad MH, Mullan R, Erickson D, Harris K, Nadeem S, Ennis R, Erwin PJ, Montori VM**, Accuracy of diagnostic tests for Cushing's syndrome: a systematic review and metaanalyses, *J Clin Endocrinol Metab* 93:1553, 2008.
  310. **Biller BM, Grossman AB, Stewart PM, Melmed S, Bertagna X, Bertherat J, Buchfelder M, Colao A, Hermus AR, Hofland LJ, Klibanski A, Lacroix A, Lindsay JR, Newell-Price J, Nieman LK, Petersenn S, Sonino N, Stalla GK, Swearingen B, Vance ML, Wass JA, Boscaro M**, Treatment of adrenocorticotropin-dependent Cushing's syndrome: a consensus statement, *J Clin Endocrinol Metab* 93:2454, 2008.
  311. **Giustina A, Barkan A, Casanueva FF, Cavagnini F, Frohman L, Ho K, Veldhuis J, Wass J, Von Werder K, Melmed S**, Criteria for cure of acromegaly: a consensus statement, *J Clin Endocrinol Metab* 85:526, 2000.
  312. **Chahal J, Schlechte J**, Hyperprolactinemia, *Pituitary* 11:141, 2008.
  313. **Schlechte J, Sherman B, Halmi N, VanGilder J, Chapler F, Dolan K, Granner D, Duello T, Harris C**, Prolactin-secreting pituitary tumors in amenorrhic women: a comprehensive study, *Endocr Rev* 1:295, 1980.
  314. **Klibanski A, Biller BM, Rosenthal DI, Schoenfeld DA, Saxe V**, Effects of prolactin and estrogen deficiency in amenorrhic bone loss, *J Clin Endocrinol Metab* 67:124, 1988.
  315. **Colao A, Loche S, Cappa M, Di Sarno A, Landi ML, Sarnacchiaro F, Faccioli G, Lombardi G**, Prolactinomas in children and adolescents. Clinical presentation and long-term follow-up, *J Clin Endocrinol Metab* 83:2777, 1998.
  316. **Vance ML, Evans WS, Thorner MO**, Drugs five years later. Bromocriptine, *Ann Intern Med* 100:78, 1984.
  317. **Di Sarno A, Landi ML, Marzullo P, Di Somma C, Pivonello R, Cerbone G, Lombardi G, Colao A**, The effect of quinagolide and cabergoline, two selective dopamine receptor type 2 agonists, in the treatment of prolactinomas, *Clin Endocrinol (Oxf)* 53:53, 2000.
  318. **Molitch ME, Elton RL, Blackwell RE, Caldwell B, Chang RJ, Jaffe R, Joplin G, Robbins RJ, Tyson J, Thorner MO**, Bromocriptine as primary therapy for prolactin-secreting macroadenomas: results of a prospective multicenter study, *J Clin Endocrinol Metab* 60:698, 1985.
  319. **Moster ML, Savino PJ, Schatz NJ, Snyder PJ, Sergott RC, Bosley TM**, Visual function in prolactinoma patients treated with bromocriptine, *Ophthalmology* 92:1332, 1985.
  320. **Colao A, Di Sarno A, Landi ML, Cirillo S, Sarnacchiaro F, Faccioli G, Pivonello R, Cataldi M, Merola B, Annunziato L, Lombardi G**, Long-term and low-dose treatment with cabergoline induces macroprolactinoma shrinkage, *J Clin Endocrinol Metab* 82:3574, 1997.
  321. **Essais O, Bouguerra R, Hamzaoui J, Marrakchi Z, Hadjri S, Chamakhi S, Zidi B, Ben Slama C**, Efficacy and safety of bromocriptine in the treatment of macroprolactinomas, *Ann Endocrinol* 63:524, 2002.
  322. **Liuzzi A, Dallabonzana D, Oppizzi G, Verde GG, Cozzi R, Chiodini P, Luccarelli G**, Low doses of dopamine agonists in the long-term treatment of macroprolactinomas, *N Engl J Med* 313:656, 1985.
  323. **Passos VQ, Souza JJ, Musolino NR, Bronstein MD**, Long-term follow-up of prolactinomas:

- normoprolactinemia after bromocriptine withdrawal, *J Clin Endocrinol Metab* 87:3578, 2002.
324. **Colao A, Di Sarno A, Cappabianca P, Di Somma C, Pivonello R, Lombardi G**, Withdrawal of long-term cabergoline therapy for tumoral and nontumoral hyperprolactinemia, *N Engl J Med* 349:2023, 2003.
325. **Serri O, Rasio E, Beauregard H, Hardy J, Somma M**, Recurrence of hyperprolactinemia after selective transsphenoidal adenomectomy in women with prolactinoma, *N Engl J Med* 309:280, 1983.
326. **Schlechte JA, Sherman BM, Chapler FK, VanGilder J**, Long term follow-up of women with surgically treated prolactin-secreting pituitary tumors, *J Clin Endocrinol Metab* 62:1296, 1986.
327. **Losa M, Mortini P, Barzaghi R, Gioia L, Giovanelli M**, Surgical treatment of prolactin-secreting pituitary adenomas: early results and long-term outcome, *J Clin Endocrinol Metab* 87:3180, 2002.
328. **Feigenbaum SL, Downey DE, Wilson CB, Jaffe RB**, Transsphenoidal pituitary resection for preoperative diagnosis of prolactin-secreting pituitary adenoma in women: long term follow-up, *J Clin Endocrinol Metab* 81:1711, 1996.
329. **Littley MD, Shalet SM, Reid H, Beardwell CG, Sutton ML**, The effect of external pituitary irradiation on elevated serum prolactin levels in patients with pituitary macroadenomas, *Q J Med* 81:985, 1991.
330. **Tsagarakis S, Grossman A, Plowman PN, Jones AE, Touzel R, Rees LH, Wass JA, Besser GM**, Megavoltage pituitary irradiation in the management of prolactomas: long-term follow-up, *Clin Endocrinol (Oxf)* 34:399, 1991.
331. **Snyder PJ, Fowble BF, Schatz NJ, Savino PJ, Gennarelli TA**, Hypopituitarism following radiation therapy of pituitary adenomas, *Am J Med* 81:457, 1986.
332. **Molitch ME**, Pregnancy and the hyperprolactinemic woman, *N Engl J Med* 312:1364, 1985.
333. **Kupersmith MJ, Rosenberg C, Kleinberg D**, Visual loss in pregnant women with pituitary adenomas, *Ann Intern Med* 121:473, 1994.
334. **Casanueva FF, Molitch ME, Schlechte JA, Abs R, Bonert V, Bronstein MD, Brue T, Cappabianca P, Colao A, Fahlbusch R, Fideleff H, Hadani M, Kelly P, Kleinberg D, Laws E, Marek J, Scanlon M, Sobrinho LG, Wass JA, Giustina A**, Guidelines of the Pituitary Society for the diagnosis and management of prolactinomas, *Clin Endocrinol (Oxf)* 65:265, 2006.
335. **Gonzalez JG, Elizondo G, Saldivar D, Nanez H, Todd LE, Villarreal JZ**, Pituitary gland growth during normal pregnancy: an in vivo study using magnetic resonance imaging, *Am J Med* 85:217, 1988.
336. **Molitch ME**, Management of prolactinomas during pregnancy, *J Reprod Med* 44:1121, 1999.
337. **De Wit W, Coelingh Bennink HJT, Gerards LJ**, Prophylactic bromocriptine treatment during pregnancy in women with macroprolactinomas: report of 13 pregnancies, *Br J Obstet Gynaecol* 91:1059, 1984.
338. **Ruiz-Velasco V, Tolis G**, Pregnancy in hyperprolactinemic women, *Fertil Steril* 41:793, 1984.
339. **Holmgren U, Bergstrand G, Hagenfeldt K, Werner S**, Women with prolactinoma—effect of pregnancy and lactation on serum prolactin and on tumour growth, *Acta Endocrinol (Copenh)* 111:452, 1986.
340. **Bronstein MD, Salgado LR, de Castro Musolino NR**, Medical management of pituitary adenomas: the special case of management of the pregnant woman, *Pituitary* 5:99, 2002.
341. **Molitch ME, Russell EJ**, The pituitary “incidentaloma”, *Ann Intern Med* 112:925, 1990.
342. **Sanno N, Oyama K, Tahara S, Teramoto A, Kato Y**, A survey of pituitary incidentaloma in Japan, *Eur J Endocrinol* 149:123, 2003.
343. **Donovan LE, Corenblum B**, The natural history of the pituitary incidentaloma, *Arch Intern Med* 155:181, 1995.
344. **Feldkamp J, Santen R, Harms E, Aulich A, Modder U, Scherbaum WA**, Incidentally discovered pituitary lesions: high frequency of macroadenomas and hormone-secreting adenomas—results of a prospective study, *Clin Endocrinol (Oxf)* 51:109, 1999.
345. **King JT Jr, Justice AC, Aron DC**, Management of incidental pituitary microadenomas: a cost-effectiveness analysis, *J Clin Endocrinol Metab* 82:3625, 1997.
346. **Hodgson SF, Randall RV, Holman CB, MacCarty CS**, Empty sella syndrome, *Med Clin North Am* 56:897, 1972.
347. **Speroff L, Levin RM, Haning RV Jr, Kase NG**, A practical approach for the evaluation of women with abnormal polytomography or elevated prolactin levels, *Am J Obstet Gynecol* 135:896, 1979.

348. **Durodoye OM, Mendlovic DB, Brenner RS, Morrow JS**, Endocrine disturbances in empty sella syndrome: case reports and review of literature, *Endocr Pract* 11:120, 2005.
349. **Sheehan HL, Murdoch R**, Postpartum necrosis of the anterior pituitary: pathological and clinical aspects, *J Obstet Gynaecol Br Emp* 45:456, 1938.
350. **Zargar AH, Singh B, Laway BA, Masoodi SR, Wani AI, Bashir MI**, Epidemiologic aspects of postpartum pituitary hypofunction (Sheehan's syndrome), *Fertil Steril* 84:523, 2005.
351. **Kelestimir F**, Sheehan's syndrome, *Pituitary* 6:181, 2003.
352. **Dokmetas HS, Kilicli F, Korkmaz S, Yonem O**, Characteristic features of 20 patients with Sheehan's syndrome, *Gynecol Endocrinol* 22:279, 2006.
353. **Sert M, Tetiker T, Kirim S, Kocak M**, Clinical report of 28 patients with Sheehan's syndrome, *Endocr J* 50:297, 2003.
354. **Chung RT, Misdraji J, Sahani DV**, Case records of the Massachusetts General Hospital. Case 33-2006. A 43-year-old man with diabetes, hypogonadism, cirrhosis, arthralgias, and fatigue, *N Engl J Med* 355:1812, 2006.
355. **McDermott JH, Walsh CH**, Hypogonadism in hereditary hemochromatosis, *J Clin Endocrinol Metab* 90:2451, 2005.
356. **Yen AW, Fancher TL, Bowlus CL**, Revisiting hereditary hemochromatosis: current concepts and progress, *Am J Med* 119:391, 2006.
357. **Vance ML**, Hypopituitarism, *N Engl J Med* 330:1651, 1994.
358. **Lewis AS, Courtney CH, Atkinson AB**, All patients with 'idiopathic' hypopituitarism should be screened for hemochromatosis, *Pituitary* 12(3):273, 2008.
359. **Ezzat S, Josse RG**, Autoimmune hypophysitis, *Trends Endocrinol Metab* 8:74, 1997.
360. **Thodou E, Asa SL, Kontogeorgos G, Kovacs K, Horvath E, Ezzat S**, Clinical case seminar: lymphocytic hypophysitis: clinicopathological findings, *J Clin Endocrinol Metab* 80:2302, 1995.
361. **De Bellis A, Ruocco G, Battaglia M, Conte M, Coronella C, Tirelli G, Bellastella A, Pane E, Sinisi AA, Bizzarro A, Bellastella G**, Immunological and clinical aspects of lymphocytic hypophysitis, *Clin Sci (Lond)* 114:413, 2008.
362. **Stuart CA, Neelon FA, Lebovitz HE**, Hypothalamic insufficiency: the cause of hypopituitarism in sarcoidosis, *Ann Intern Med* 88:589, 1978.
363. **Ranjan A, Chandy MJ**, Intracellular tuberculoma, *Br J Neurosurg* 8:179, 1994.
364. **Summers VK, Hipkin LJ, Osborne Hughes R, Davis JC**, Panhypopituitarism after cured tuberculous meningitis, *Br Med J* 1:359, 1968.
365. **Practice Committee of American Society for Reproductive Medicine**, Current evaluation of amenorrhea, *Fertil Steril* 90:S219, 2008.
366. **Berga SL**, Behaviorally induced reproductive compromise in women and men, *Semin Reprod Endocrinol* 15:47, 1997.
367. **Warren MP, Voussoughian F, Geer EB, Hyle EP, Adberg CL, Ramos RH**, Functional hypothalamic amenorrhea: hypoleptinemia and disordered eating, *J Clin Endocrinol Metab* 84:873, 1999.
368. **Laughlin GA, Dominguez CE, Yen SS**, Nutritional and endocrine-metabolic aberrations in women with functional hypothalamic amenorrhea, *J Clin Endocrinol Metab* 83:25, 1998.
369. **Marcus MD, Loucks TL, Berga SL**, Psychological correlates of functional hypothalamic amenorrhea, *Fertil Steril* 76:310, 2001.
370. **Perkins RB, Hall JE, Martin KA**, Neuroendocrine abnormalities in hypothalamic amenorrhea: spectrum, stability, and response to neurotransmitter modulation, *J Clin Endocrinol Metab* 84:1905, 1999.
371. **Allouche J, Bennet A, Barbe P, Plantavid M, Caron P, Louvet JP**, LH pulsatility and in vitro bioactivity in women with anorexia nervosa-related hypothalamic amenorrhea, *Acta Endocrinol (Copenh)* 125:614, 1991.
372. **Berga SL, Mortola JF, Girton L, Suh B, Laughlin G, Pham P, Yen SS**, Neuroendocrine aberrations in women with functional hypothalamic amenorrhea, *J Clin Endocrinol Metab* 68:301, 1989.
373. **Biller BM, Federoff HJ, Koenig JI, Klibanski A**, Abnormal cortisol secretion and responses to corticotropin-releasing hormone in women with hypothalamic amenorrhea, *J Clin Endocrinol Metab* 70:311, 1990.

374. **Berga SL, Daniels TL, Giles DE**, Women with functional hypothalamic amenorrhea but not other forms of anovulation display amplified cortisol concentrations, *Fertil Steril* 67:1024, 1997.
375. **Olster DH, Ferin M**, Corticotropin-releasing hormone inhibits gonadotropin secretion in the ovariectomized Rhesus monkey, *J Clin Endocrinol Metab* 65: 262, 1987.
376. **Kondoh Y, Uemura T, Murase M, Yokoi N, Ishikawa M, Hirahara F**, A longitudinal study of disturbances of the hypothalamic-pituitary-adrenal axis in women with progestin-negative functional hypothalamic amenorrhea, *Fertil Steril* 76:748, 2001.
377. **Berga SL, Loucks AB, Rossmanith WG, Kettel LM, Laughlin GA, Yen SS**, Acceleration of luteinizing hormone pulse frequency in functional hypothalamic amenorrhea by dopaminergic blockade, *J Clin Endocrinol Metab* 72:151, 1991.
378. **Hirvonen E**, Etiology, clinical features and prognosis in secondary amenorrhea, *Int J Fertil* 22:69, 1977.
379. **Falsetti L, Gambera A, Barbetti L, Specchia C**, Long-term follow-up of functional hypothalamic amenorrhea and prognostic factors, *J Clin Endocrinol Metab* 87:500, 2002.
380. **Perkins RB, Hall JE, Martin KA**, Aetiology, previous menstrual function and patterns of neuro-endocrine disturbance as prognostic indicators in hypothalamic amenorrhoea, *Hum Reprod* 16:2198, 2001.
381. **Copeland PM, Sacks NR, Herzog DB**, Longitudinal follow-up of amenorrhea in eating disorders, *Psychosom Med* 57:121, 1995.
382. **Lacey JH**, Anorexia nervosa and a bearded female saint, *Br Med J* 285:1816, 1982.
383. **Eaton DK, Kann L, Kinchen S, Ross J, Hawkins J, Harris WA, Lowry R, McManus T, Chyen D, Shanklin S, Lim C, Grunbaum JA, Wechsler H**, Youth risk behavior surveillance—United States, 2005, *MMWR Surveill Summ* 55:1, 2006.
384. **Hoek HW, van Hoeken D**, Review of the prevalence and incidence of eating disorders, *Int J Eat Disord* 34:383, 2003.
385. **Hudson JI, Hiripi E, Pope HG Jr, Kessler RC**, The prevalence and correlates of eating disorders in the National Comorbidity Survey Replication, *Biol Psychiatry* 61:348, 2007.
386. **Keski-Rahkonen A, Hoek HW, Susser ES, Linna MS, Sihvola E, Raevuori A, Bulik CM, Kaprio J, Rissanen A**, Epidemiology and course of anorexia nervosa in the community, *Am J Psychiatry* 164:1259, 2007.
387. **Fairburn CG, Beglin SJ**, Studies of the epidemiology of bulimia nervosa, *Am J Psychiatry* 147:401, 1990.
388. **Patton GC, Selzer R, Coffey C, Carlin JB, Wolfe R**, Onset of adolescent eating disorders: population based cohort study over 3 years, *Br Med J* 318:765, 1999.
389. **The McKnight Investigators**, Risk factors for the onset of eating disorders in adolescent girls: results of the McKnight longitudinal risk factor study, *Am J Psychiatry* 160:248, 2003.
390. **Sanci L, Coffey C, Olsson C, Reid S, Carlin JB, Patton G**, Childhood sexual abuse and eating disorders in females: findings from the Victorian Adolescent Health Cohort Study, *Arch Pediatr Adolesc Med* 162:261, 2008.
391. **Grice DE, Halmi KA, Fichter MM, Strober M, Woodside DB, Treasure JT, Kaplan AS, Magistretti PJ, Goldman D, Bulik CM, Kaye WH, Berrettini WH**, Evidence for a susceptibility gene for anorexia nervosa on chromosome 1, *Am J Hum Genet* 70:787, 2002.
392. **Bulik CM, Devlin B, Bacanu SA, Thornton L, Klump KL, Fichter MM, Halmi KA, Kaplan AS, Strober M, Woodside DB, Bergen AW, Ganjei JK, Crow S, Mitchell J, Rotondo A, Mauri M, Cassano G, Keel P, Berrettini WH, Kaye WH**, Significant linkage on chromosome 10p in families with bulimia nervosa, *Am J Hum Genet* 72:200, 2003.
393. **Herzog DB, Nussbaum KM, Marmor AK**, Comorbidity and outcome in eating disorders, *Psychiatr Clin North Am* 19:843, 1996.
394. **Diagnostic and Statistical Manual of Mental Disorders**, 4th ed, American Psychiatric Association, Washington, DC, 1994.
395. **Miller KK, Grinspoon SK, Ciampa J, Hier J, Herzog D, Klibanski A**, Medical findings in outpatients with anorexia nervosa, *Arch Intern Med* 165:561, 2005.
396. **King MB**, Eating disorders in a general practice population. Prevalence, characteristics and follow-up at 12 to



18 months, *Psychol Med Monogr Suppl* 14:1, 1989.

397. **Steinhausen HC**, The outcome of anorexia nervosa in the 20th century, *Am J Psychiatry* 159:1284, 2002.
398. **Mayer LE, Roberto CA, Glasofer DR, Etu SF, Gallagher D, Wang J, Heymsfield SB, Pierson RN Jr, Attia E, Devlin MJ, Walsh BT**, Does percent body fat predict outcome in anorexia nervosa?, *Am J Psychiatry* 164:970, 2007.
399. **Bolton JG, Patel S, Lacey JH, White S**, A prospective study of changes in bone turnover and bone density associated with regaining weight in women with anorexia nervosa, *Osteoporos Int* 16:1955, 2005.
400. **Bass SL, Saxon L, Corral AM, Rodda CP, Strauss BJ, Reidpath D, Clarke C**, Near normalisation of lumbar spine bone density in young women with osteopenia recovered from adolescent onset anorexia nervosa: a longitudinal study, *J Pediatr Endocrinol Metab* 18:897, 2005.
401. **Miller KK, Lee EE, Lawson EA, Misra M, Minihan J, Grinspoon SK, Gleysteen S, Mickley D, Herzog D, Klibanski A**, Determinants of skeletal loss and recovery in anorexia nervosa, *J Clin Endocrinol Metab* 91:2931, 2006.
402. **Golden NH, Lanzkowsky L, Schebendach J, Palestro CJ, Jacobson MS, Shenker IR**, The effect of estrogen-progestin treatment on bone mineral density in anorexia nervosa, *J Pediatr Adolesc Gynecol* 15:135, 2002.
403. **Strokosch GR, Friedman AJ, Wu SC, Kamin M**, Effects of an oral contraceptive (norgestimate/ethinyl estradiol) on bone mineral density in adolescent females with anorexia nervosa: a double-blind, placebo-controlled study, *J Adolesc Health* 39:819, 2006.
404. **Klibanski A, Biller BM, Schoenfeld DA, Herzog DB, Saxe VC**, The effects of estrogen administration on trabecular bone loss in young women with anorexia nervosa, *J Clin Endocrinol Metab* 80:898, 1995.
405. **Soyka LA, Misra M, Frenchman A, Miller KK, Grinspoon S, Schoenfeld DA, Klibanski A**, Abnormal bone mineral accrual in adolescent girls with anorexia nervosa, *J Clin Endocrinol Metab* 87:4177, 2002.
406. **Siega-Riz AM, Adair LS, Hobel CJ**, Maternal underweight status and inadequate rate of weight gain during the third trimester of pregnancy increases the risk of preterm delivery, *J Nutr* 126:146, 1996.
407. **Franko DL, Spurrell EB**, Detection and management of eating disorders during pregnancy, *Obstet Gynecol* 95:942, 2000.
408. **Franko DL, Blais MA, Becker AE, Delinsky SS, Greenwood DN, Flores AT, Ekeblad ER, Eddy KT, Herzog DB**, Pregnancy complications and neonatal outcomes in women with eating disorders, *Am J Psychiatry* 158:1461, 2001.
409. **Sollid CP, Wisborg K, Hjort J, Secher NJ**, Eating disorder that was diagnosed before pregnancy and pregnancy outcome, *Am J Obstet Gynecol* 190:206, 2004.
410. **Micali N, Simonoff E, Treasure J**, Risk of major adverse perinatal outcomes in women with eating disorders, *Br J Psychiatry* 190:255, 2007.
411. **Stewart DE, Raskin J, Garfinkel PE, MacDonald OL, Robinson GE**, Anorexia nervosa, bulimia, and pregnancy, *Am J Obstet Gynecol* 157:1194, 1987.
412. **Morgan JF, Lacey JH, Sedgwick PM**, Impact of pregnancy on bulimia nervosa, *Br J Psychiatry* 174:135, 1999.
413. **Norre J, Vandereycken W, Gordts S**, The management of eating disorders in a fertility clinic: clinical guidelines, *J Psychosom Obstet Gynaecol* 22:77, 2001.
414. **Russell GF, Treasure J, Eisler I**, Mothers with anorexia nervosa who underfeed their children: their recognition and management, *Psychol Med* 28:93, 1998.
415. **Frisch RE, Wyshak G, Vincent L**, Delayed menarche and amenorrhea in ballet dancers, *N Engl J Med* 303:17, 1980.
416. **Prior JC, Vigna Y**, Gonadal steroids in athletic women. Contraception, complications and performance, *Sports Med* 2:287, 1985.
417. **Loucks AB, Mortola JF, Girton L, Yen SS**, Alterations in the hypothalamic-pituitary-ovarian and the hypothalamic-pituitary-adrenal axes in athletic women, *J Clin Endocrinol Metab* 68:402, 1989.
418. **Frisch RE**, Body fat, menarche, fitness and fertility, *Hum Reprod* 2:521, 1987.
419. **Baker ER**, Body weight and the initiation of puberty, *Clin Obstet Gynecol* 28:573, 1985.

420. **Bronson FH, Manning JM**, The energetic regulation of ovulation: a realistic role for body fat, *Biol Reprod* 44:945, 1991.
421. **Warren MP**, Anorexia nervosa and related eating disorders, *Clin Obstet Gynecol* 28:588, 1985.
422. **Loucks AB, Thuma JR**, Luteinizing hormone pulsatility is disrupted at a threshold of energy availability in regularly menstruating women, *J Clin Endocrinol Metab* 88:297, 2003.
423. **Howlett TA, Tomlin S, Ngahfoong L, Rees LH, Bullen BA, Skrinar GS, McArthur JW**, Release of beta endorphin and met-enkephalin during exercise in normal women: response to training, *Br Med J (Clin Res Ed)* 288:1950, 1984.
424. **Russell JB, Mitchell DE, Musey PI, Collins DC**, The role of beta-endorphins and catechol estrogens on the hypothalamic-pituitary axis in female athletes, *Fertil Steril* 42:690, 1984.
425. **Laatikainen T, Virtanen T, Apter D**, Plasma immunoreactive beta-endorphin in exercise-associated amenorrhea, *Am J Obstet Gynecol* 154:94, 1986.
426. **Harber VJ, Sutton JR, MacDougall JD, Woolever CA, Bhavnani BR**, Plasma concentrations of beta-endorphin in trained eumenorrheic and amenorrheic women, *Fertil Steril* 67:648, 1997.
427. **Chrousos GP, Gold PW**, The concepts of stress and stress system disorders: overview of physical and behavioral homeostasis, *JAMA* 267:1244, 1992.
428. **Dorn LD, Chrousos GP**, The neurobiology of stress: understanding regulation of affect during female biological transitions, *Semin Reprod Endocrinol* 15:19, 1997.
429. **Warren MP, Stiehl AL**, Exercise and female adolescents: effects on the reproductive and skeletal systems, *J Am Med Womens Assoc* 54:115, 1999.
430. **Laughlin GA, Yen SS**, Hypoleptinemia in women athletes: absence of a diurnal rhythm with amenorrhea, *J Clin Endocrinol Metab* 82:318, 1997.
431. **Welt CK, Chan JL, Bullen J, Murphy R, Smith P, DePaoli AM, Karalis A, Mantzoros CS**, Recombinant human leptin in women with hypothalamic amenorrhea, *N Engl J Med* 351:987, 2004.
432. **Williams NI, Helmreich DL, Parfitt DB, Caston-Balderrama A, Cameron JL**, Evidence for a causal role of low energy availability in the induction of menstrual cycle disturbances during strenuous exercise training, *J Clin Endocrinol Metab* 86:5184, 2001.
433. **Loucks AB**, Energy availability, not body fatness, regulates reproductive function in women, *Exerc Sport Sci Rev* 31:144, 2003.
434. **Constantini NW, Warren MP**, Menstrual dysfunction in swimmers: a distinct entity, *J Clin Endocrinol Metab* 80:2740, 1995.
435. **Robinson TL, Snow-Harter C, Taaffe DR, Gillis D, Shaw J, Marcus R**, Gymnasts exhibit higher bone mass than runners despite similar prevalence of amenorrhea and oligomenorrhea, *J Bone Miner Res* 10:26, 1995.
436. **Young N, Formica C, Szmukler G, Seeman E**, Bone density at weight-bearing and nonweight-bearing sites in ballet dancers: the effects of exercise, hypogonadism, and body weight, *J Clin Endocrinol Metab* 78:449, 1994.
437. **Morris FL, Smith RM, Payne WR, Galloway MA, Wark JD**, Compressive and shear force generated in the lumbar spine of female rowers, *Int J Sports Med* 21:518, 2000.
438. **Warren MP, Brooks-Gunn J, Fox RP, Lancelot C, Newman D, Hamilton WG**, Lack of bone accretion and amenorrhea: evidence for a relative osteopenia in weight-bearing bones, *J Clin Endocrinol Metab* 72:847, 1991.
439. **Warren MP, Perloth NE**, The effects of intense exercise on the female reproductive system, *J Endocrinol* 170:3, 2001.
440. **Warren MP, Brooks-Gunn J, Fox RP, Holderness CC, Hyle EP, Hamilton WG**, Osteopenia in exercise-associated amenorrhea using ballet dancers as a model: a longitudinal study, *J Clin Endocrinol Metab* 87:3162, 2002.
441. **Theintz G, Buchs B, Rizzoli R, Slosman D, Clavien H, Sizonenko PC, Bonjour JP**, Longitudinal monitoring of bone mass accumulation in healthy adolescents: evidence for a marked reduction after 16 years of age at the levels of lumbar spine and femoral neck in female subjects, *J Clin Endocrinol Metab* 75:1060,

1992.

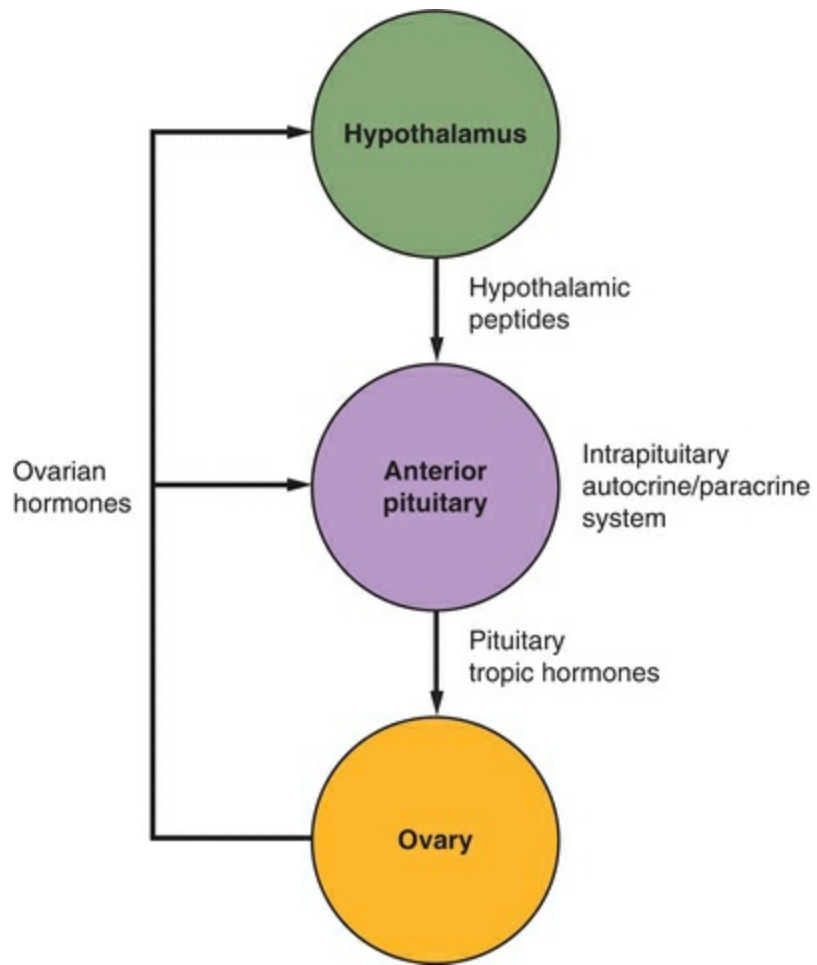
442. **Matkovic V, Jelic T, Wardlaw GM, Ilich JZ, Goel PK, Wright JK, Andon MB, Smith KT, Heaney RP**, Timing of peak bone mass in Caucasian females and its implication for the prevention of osteoporosis. Inference from a cross-sectional model, *J Clin Invest* 93:799, 1994.
443. **Rickenlund A, Carlstrom K, Ekblom B, Brismar TB, Von Schoultz B, Hirschberg AL**, Effects of oral contraceptives on body composition and physical performance in female athletes, *J Clin Endocrinol Metab* 89:4364, 2004.
444. **Hotta M, Shibasaki T, Sato K, Demura H**, The importance of body weight history in the occurrence and recovery of osteoporosis in patients with anorexia nervosa: evaluation by dual X-ray absorptiometry and bone metabolic markers, *Eur J Endocrinol* 139:276, 1998.
445. **Warren MP, Brooks-Gunn J, Fox RP, Holderness CC, Hyle EP, Hamilton WG, Hamilton L**, Persistent osteopenia in ballet dancers with amenorrhea and delayed menarche despite hormone therapy: a longitudinal study, *Fertil Steril* 80:398, 2003.
446. **Warren MP, Miller KK, Olson WH, Grinspoon SK, Friedman AJ**, Effects of an oral contraceptive (norgestimate/ethinyl estradiol) on bone mineral density in women with hypothalamic amenorrhea and osteopenia: an open-label extension of a double-blind, placebo-controlled study, *Contraception* 72:206, 2005.
447. **Vescovi JD, Jamal SA, De Souza MJ**, Strategies to reverse bone loss in women with functional hypothalamic amenorrhea: a systematic review of the literature, *Osteoporos Int* 19(4):465, 2008.
448. **Stathopoulos IP, Liakou CG, Katsalira A, Trovas G, Lyritis GG, Papaioannou NA, Tournis S**, The use of bisphosphonates in women prior to or during pregnancy and lactation, *Hormones (Athens)* 10(4):280, 2011.
449. **Spratt DI, Carr DB, Merriam GR, Scully RE, Rao PN, Crowley WF Jr**, The spectrum of abnormal patterns of gonadotropin-releasing hormone secretion in men with idiopathic hypogonadotropic hypogonadism: clinical and laboratory correlations, *J Clin Endocrinol Metab* 64:283, 1987.
450. **Caron P, Chauvin S, Christin-Maitre S, Bennet A, Lahlou N, Counis R, Bouchard P, Kottler ML**, Resistance of hypogonadic patients with mutated GnRH receptor genes to pulsatile GnRH administration, *J Clin Endocrinol Metab* 84:990, 1999.
451. **Crowley WF Jr, Jameson JL**, Clinical counterpoint: gonadotropin-releasing hormone deficiency: perspectives from clinical investigation, *Endocr Rev* 13:635, 1992.
452. **Legouis R, Hardelin JP, Levilliers J, Claverie JM, Compain S, Wunderle V, Millasseau P, Le Paslier D, Cohen D, Caterina D**, et al., The candidate gene for the X-linked Kallmann syndrome encodes a protein related to adhesion molecules, *Cell* 67:423, 1991.
453. **Bhagavath B, Layman LC**, The genetics of hypogonadotropic hypogonadism, *Semin Reprod Med* 25:272, 2007.
454. **Hardelin JP, Dode C**, The complex genetics of Kallmann syndrome: KAL1, FGFR1, FGF8, PROKR2, PROK2, et al., *Sex Dev* 2:181, 2008.

---

# Chronic Anovulation and the Polycystic Ovary Syndrome

Anovulation is very common and has a number of different clinical manifestations, including amenorrhea, oligomenorrhea, and abnormal uterine bleeding. The condition, if long lasting, also has serious potential consequences, such as infertility and an increased risk for developing endometrial hyperplasia and neoplasia consequent to chronic estrogen dominance that remains unopposed by progesterone. In many anovulatory women, the pathophysiology for ovulatory dysfunction involves insulin resistance; these women are at an increased lifetime risk of developing type II diabetes mellitus and possibly also at risk for cardiovascular disease. In others, overt hypoestrogenism that results from disrupted ovarian folliculogenesis and chronic anovulation is associated with an increased risk for low bone mass and an enhanced lifetime fracture risk. All clinicians who care for women must therefore be thoroughly familiar with the evaluation and management of anovulatory women.

Normal ovulatory function requires coordination at all levels of the hypothalamic-pituitary-ovarian (HPO) axis (discussed in [Chapter 5](#)), and anovulation can result from disruption of functioning at any level of the HPO axis ([Figure 11.1](#)). This chapter considers the variety of mechanisms that can cause anovulation and the clinical consequences of chronic anovulation, focusing on the most common chronic anovulatory disorder, the polycystic ovary syndrome (PCOS), and its management.



**FIGURE 11.1**

# CAUSES OF ANOVULATION

---

The complex interaction of neuroendocrine, intraovarian, and endometrial mechanisms that regulate the normal ovulatory menstrual cycle is discussed in detail in other chapters in this text ([Chapters 4 and 5](#)). These mechanisms are summarized briefly here, to provide the foundation for subsequent discussion of the pathophysiology of anovulation.

As the corpus luteum regresses and the menstrual cycle draws to a close in the late luteal phase, serum concentrations of ovarian hormones estradiol, progesterone, and inhibin A decline to basal levels, releasing the hypothalamic-pituitary components of the HPO axis from their collective negative feedback effects. Accordingly, pulse frequency of the hypothalamic gonadotropin-releasing hormone (GnRH) secretion increases, which in turn stimulates pituitary secretion of follicle-stimulating hormone (FSH) secretion. Pituitary FSH in turn serves to “recruit” a new cohort of the ovarian small antral follicles or, more accurately, to rescue a group of follicles from an otherwise programmed demise via apoptosis. During the early follicular phase of the menstrual cycle, the serum concentration of inhibin B, which is secreted by the recruited pool of small growth and estrogen production ([Chapter 5](#)), rises progressively. This rise in circulating levels of inhibin B during the early follicular phase of the menstrual cycle in turn keeps the pituitary output of FSH in check through negative feedback, thus serving to control pituitary influence on ovarian follicular growth.

During the midfollicular phase of the menstrual cycle, ovarian autocrine and paracrine mechanisms involving activin and insulin-like growth factors enhance FSH-stimulated aromatase activity in ovarian follicular granulosa cells to help create and sustain the estrogenic microenvironment that is required for continued follicular growth and development. Whereas an estrogenic follicular milieu fosters further growth, an androgenic milieu promotes follicle atresia. As the serum inhibin B concentration reaches its peak, estradiol and inhibin A levels, derived from the granulosa cells of growing follicles in the cohort, begin increasing steadily. In response to their combined negative feedback effects, pituitary luteinizing hormone (LH) pulse amplitude decreases and pulse frequency increases (presumably reflecting the pattern of hypothalamic GnRH secretion), and serum concentrations of both FSH and LH fall gradually. Declining FSH levels remain sufficient to support continued growth of the selected dominant follicle, which has more granulosa cells and FSH receptors and a more advanced microvasculature compared to the remainder of smaller follicles in the recruited cohort, which are unable to continue to grow in the absence of FSH action and eventually are destined to apoptotic death.

During the late follicular phase, inhibin A and insulin-like growth factors combine to promote LH-stimulated androgen production in the ovarian theca cells, which

provides substrate for aromatization to estrogen in the proliferating mass of granulosa cells within the preovulatory follicle. FSH and estradiol then combine to induce expression of LH receptors on the granulosa cells that will mediate luteinization and ovulation when the follicle reaches full maturity. Ultimately, serum levels of estradiol derived from the preovulatory follicle exceed the threshold concentration required to exert positive feedback effects centrally, acting primarily on the pituitary to induce the midcycle LH surge. The LH surge completes follicular maturation and triggers a cascade of events resulting in extrusion of the oocyte and formation of the corpus luteum. The oocyte completes the first meiotic division, and local secretion of plasminogen activator and other cytokines mediates erosion of the follicular wall, allowing the oocyte to emerge with its surrounding investment of cumulus cells. The mural granulosa cells begin to luteinize and produce progesterone and, to lesser degree, estradiol.

After ovulation, serum estradiol concentrations fall precipitously, but only transiently, before rising again in parallel with progesterone and inhibin A produced by the corpus luteum. Progesterone transforms the endometrium from a proliferative to a secretory morphology and initiates a temporally restricted cascade of events that renders the endometrium receptive to embryo implantation. As the circulating progesterone level rises to its peak during the midluteal phase, LH pulse frequency decreases again and gonadotropin levels fall progressively to their nadir in the late luteal phase. Unless pregnancy intervenes and resulting rapidly rising levels of human chorionic gonadotropin (hCG) rescue the corpus luteum and stimulate continued high-level progesterone secretion, the corpus luteum has a finite life span and eventually regresses; progressive decline in estradiol and progesterone levels accompanies a failing corpus luteum, and this withdrawal of hormonal support for the endometrium results in a series of events that culminate in onset of menses ([Chapter 5](#)).

# Central Defects as a Cause of Anovulation

Although difficult to demonstrate, hypothalamic dysfunction offers both a logical and likely explanation for ovulatory dysfunction. A normal pituitary response to feedback signals from the follicle requires pulsatile GnRH secretion within a critical range for both pulse frequency and amplitude. The onset of puberty in girls results from decreasing central inhibition of GnRH neuronal activity and increasing pulsatile GnRH secretion, which stimulates a progressive increase in pituitary gonadotropin release and, in turn, ovarian follicular menstrual characteristics in adolescent girls typically vary until the HPO axis matures and the positive feedback relationship between estradiol and gonadotropin secretion and ovulation becomes established. **Factors that reactivate central inhibitory mechanisms, such as emotional, nutritional (weight loss, eating disorders), pharmacologic (opiates or dopaminergic agonists), or physical stress (excessive exercise), can suppress GnRH neuronal activity, leading to dysfunctional patterns of gonadotropin secretion that fail to promote progressive follicular development, resulting in anovulation.** Although such patients more commonly present with amenorrhea ([Chapter 10](#)), lesser degrees of GnRH neuronal suppression can result in homeostatic levels of pituitary-ovarian function and a euestrogenic chronic anovulatory state.

## Pituitary Tumors

Pituitary tumors can cause anovulation by inhibiting gonadotropin secretion. They may compress pituitary gonadotrophs directly or interrupt delivery of hypothalamic GnRH by compression of the pituitary stalk. Alternatively, they may cause hyperprolactinemia by interfering with the inhibitory actions of hypothalamic dopamine (the putative prolactin inhibitory hormone) on pituitary lactotrophs, resulting in a secondary suppression of pulsatile GnRH secretion ([Chapter 4](#)).

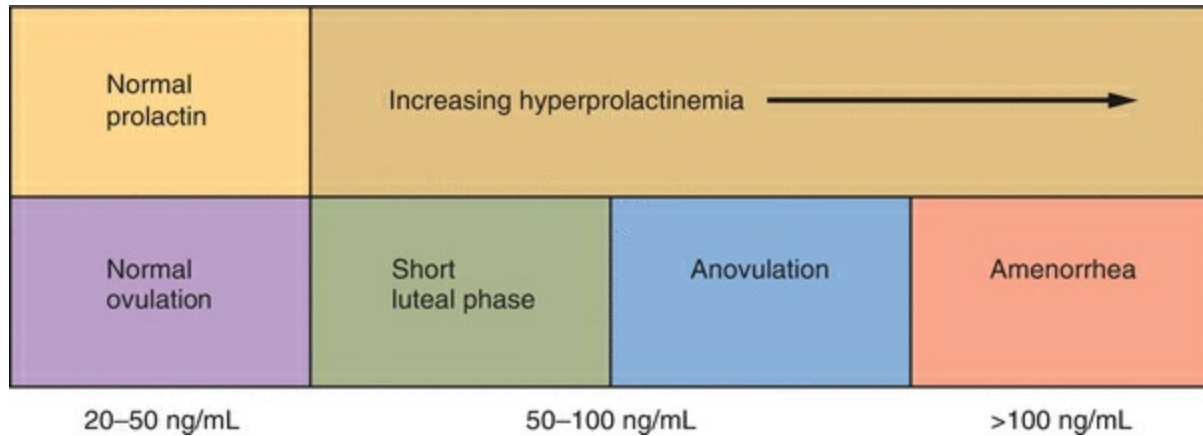
## Hyperprolactinemia

Hyperprolactinemia is another specific example of anovulation resulting from a central defect.<sup>1</sup> The mechanism involves disruption or inhibition of the normal GnRH pulse rhythm, resulting in ineffective or frankly low levels of pituitary gonadotropin secretion.<sup>2,3</sup>

Elevated prolactin levels can result in a spectrum of ovulatory dysfunction, ranging from a short luteal phase to anovulatory cycles to amenorrhea and hypogonadotropic hypogonadism, depending on the extent to which the gonadotropin secretion is disturbed or suppressed. Mild hyperprolactinemia may cause only a short luteal phase, resulting from inadequate preovulatory follicular development.<sup>1,4</sup> Moderate hyperprolactinemia



frequently causes oligomenorrhea or amenorrhea, and higher prolactin levels typically result in frank hypogonadism with low estrogen levels (Figure 11.2).<sup>5,6</sup> A breast examination with gentle compression looking for evidence of galactorrhea and measurement of the serum prolactin concentration are important parts of the evaluation of all anovulatory women.



**FIGURE 11.2**

## Abnormal Gonadotropin Secretory Dynamics

Abnormalities in GnRH pulsatility are principal drivers of abnormal gonadotropin secretion pattern and are commonly encountered in polycystic ovary syndrome (PCOS) as well as also seen with obesity-related ovulatory disturbances. Many, but not all, anovulatory women with polycystic ovaries (PCO) exhibit abnormal gonadotropin secretory dynamics.<sup>7,8</sup> The most common abnormality involving the gonadotropins is an increase in mean serum LH levels, due to an increase in both LH pulse frequency and amplitude.<sup>7,8</sup> Serum concentrations of FSH typically are normal or low. The pattern could result from a decrease in hypothalamic dopamine or opioid inhibition of pulsatile GnRH secretion,<sup>9</sup> or from abnormalities in steroid hormone feedback, including the lack of progesterone (due to anovulation)<sup>8</sup> or increased circulating androgen levels.<sup>9</sup> Other evidence from studies in nonhuman primates and women suggests strongly that prenatal exposure to increased androgen concentrations, induced by genetic and/or environmental factors, may program the GnRH pulse generator in the female fetus in such a way as to result in increased pituitary LH secretion, causing disordered follicular development and ovarian hyperandrogenism.<sup>10,11,12</sup> The increased prevalence of chronic anovulation and polycystic-appearing ovaries in women with epilepsy offers another example of how central nervous system dysfunction can disrupt the HPO axis and result in anovulation.<sup>13,14</sup>

# Abnormal Feedback Signals

Anovulation can result from abnormal estrogen feedback signals from the periphery, in two ways. Chronically elevated estrogen levels may not permit the increase in FSH secretion required to stimulate or sustain progressive follicular development (discussed in [Chapters 4 and 5](#)). Conversely, poor follicular development may not generate or sustain the estradiol level required to induce the ovulatory LH surge.

## Chronically Elevated Estrogen Concentrations

The fall in estradiol levels that normally occurs during the late luteal phase (as the corpus luteum regresses) is a prerequisite for the intercycle rise in FSH that drives the wave of new follicular development in the ensuing cycle. Sustained high levels of estrogen caused by increased production or decreased clearance and metabolism can, through negative feedback, prevent any significant increase in FSH levels, resulting in a chronic anovulatory state.

Pregnancy is the most common and obvious example of anovulation resulting from sustained high levels of estrogen production. Rare estrogen-producing ovarian tumors (e.g., granulosa cell tumors) can have the same effect. Although the adrenals do not normally secrete appreciable amounts of estrogen directly into the circulation, they contribute via their secretion of androgens (androstenedione, dehydroepiandrosterone, and its sulfate), which can be converted to estrogen in the periphery. Adipose tissue has significant aromatase activity, which converts androgens to estrogens,<sup>15</sup> thereby providing at least one mechanism for the well-known association between obesity and chronic anovulation (see below).

The clearance and metabolism of estrogen can be impaired in a variety of conditions, such as thyroid or hepatic disease. Both hyperthyroidism and hypothyroidism can cause chronic anovulation by altering the metabolic clearance and peripheral interconversion of steroid hormones.<sup>16,17,18</sup> **Hypothyroidism can be associated with elevated prolactin levels, providing the rationale for measuring serum thyroid-stimulating hormone (TSH), as well as prolactin, in the evaluation of anovulatory and amenorrheic women.** Hepatic disease also disturbs the normal clearance and metabolism of sex steroids.<sup>19</sup>

## Failure of the LH Surge

The rising estradiol levels arising from the preovulatory follicle in the late follicular phase induce the midcycle LH surge through a positive feedback effect primarily at the level of the pituitary, and this in turn stimulates ovulation (discussed in [Chapters 4 and](#)

5). Quite obviously, women with gonadal dysgenesis or ovarian failure are anovulatory because they have no remaining functional ovarian follicles and no significant estrogen production. More commonly, clinicians encounter patients with normal serum levels of gonadotropins and estradiol in whom the anovulation results from a failure to achieve complete follicular development and to generate and sustain the levels of estradiol required to induce the LH surge. Anovulatory cycles are common at extremes of reproductive ages such as in the months following menarche and in the perimenopausal period.

# Local Ovarian Conditions

Disturbance in one or more of the delicately balanced intraovarian regulatory mechanisms that serve to select the dominant follicle and allow it alone to grow and develop in the face of declining levels of FSH may lead to anovulation. Activins, inhibins, and insulin-like growth factors act via local autocrine and paracrine mechanisms to first enhance the action of FSH by increasing the concentration of FSH receptors within the dominant follicle and then act synergistically to induce the appearance of LH receptors that are required to mediate the actions of LH during the midcycle surge that drives the final stages of follicular maturation and stimulates ovulation. A follicle can thus fail to grow and ovulate due to a failure or interference with any of these local mechanisms (Chapter 5).

The “two-cell, two-gonadotropin” concept of ovarian follicular development (Chapters 4 and 5) emphasizes the critical importance of local androgen concentrations within the ovary. At low levels, ovarian androgens serve as substrate for FSH-induced aromatization and estrogen production. At higher concentrations however, intraovarian androgens are converted alternatively to more potent  $5\alpha$ -reduced androgens, which cannot be converted to estrogen and also inhibit aromatase activity and FSH induction of LH receptors on granulosa cells (Figure 11.3). Consequently, abnormally high local androgen concentrations, from any cause, impede follicular maturation, promote follicular atresia, and predispose to a chronic anovulatory state.

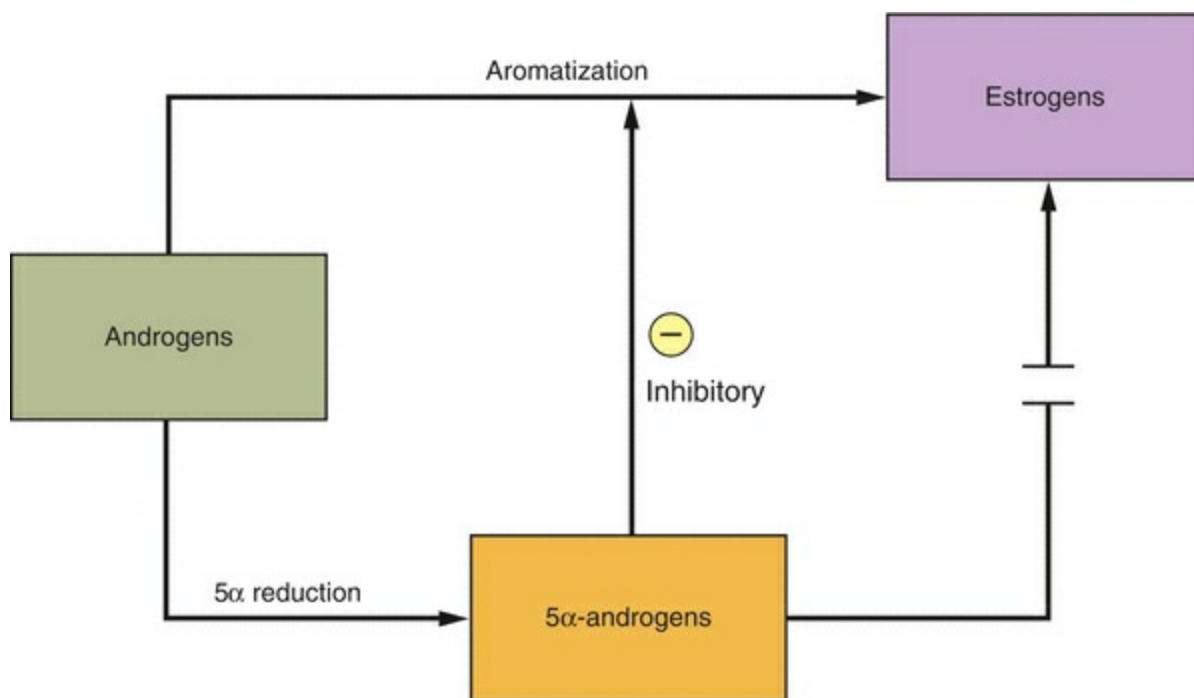


FIGURE 11.3

# Obesity

**Obesity predisposes to chronic anovulation in at least three distinct ways:**

1. Increased peripheral aromatization of androgens, resulting in chronically elevated estrogen concentrations.
2. Decreased levels of hepatic sex hormone binding globulin (SHBG) production, resulting in increased circulating concentrations of free estradiol and testosterone.
3. Insulin resistance, leading to a compensatory increase in insulin levels that stimulates androgen production in the ovarian stroma, resulting in high local androgen concentrations that impair ovarian follicular development. Importantly, mild insulin resistance as well as some degrees of hyperandrogenemia are often encountered as a physiologic phenomenon at puberty. However, both these states get exacerbated in the setting of childhood obesity.<sup>20</sup> These two features—persistent insulin resistance and elevated androgens—ultimately predispose to a PCOS phenotype in obese adolescents.<sup>19</sup>

Even modest weight loss, which results in decreased circulating insulin and androgen concentrations, frequently restores ovulatory function and normal menstrual cyclicity.<sup>21,22,23,24</sup> Therefore, in obese girls and women who are experiencing menstrual irregularity, weight reduction must be considered as a first-line management approach.

# Defining the Cause of Anovulation

Whereas the underlying cause of anovulation may be relatively clear, such as in women with ovarian failure (amenorrhea accompanied by menopausal symptoms, discussed in [Chapter 17](#)), more often than not, the exact cause for ovulatory dysfunction may not be obvious, but gets unmasked on further testing (such as hyperprolactinemia and hypothyroidism). Often however, it may not be possible to isolate the specific underlying mechanism. Goals of management are twofold: firstly, to establish or rule out identifiable causes of anovulation ([Table 11.1](#)) and, secondly, to identify the patient's prioritized goals and needs, so as to ensure that their concerns are targeted while also addressing the underlying etiology. **Women with absent or abnormal menstrual function who are otherwise healthy can be categorized as follows:**

## TABLE 11.1 Common Causes of Anovulation

Common Causes of Anovulation	Diagnosis	Reviewed Elsewhere in This Volume
Pregnancy	Elevated hCG	Chapter 7
Thyroid dysfunction	Elevated TSH—primary hypothyroidism Suppressed TSH—primary hyperthyroidism	Chapter 20
Hyperprolactinemia	Elevated prolactin Abnormal pituitary imaging	Chapter 5
Late-onset CAH	Elevated total testosterone, DHEA-S, 17-OH progesterone	Chapter 13
Obesity/insulin resistance	Elevated fasting and/or provoked insulin levels	Chapter 19
Ovarian failure	Elevated FSH Suppressed estradiol, undetectable inhibin B, AMH	Chapters 10 and 17
Iatrogenic Antianxiety/antidepressant Androgens	Elevated prolactin Elevated testosterone depending on the type of formulation	Chapter 4
Psychological stress	Prolactin may be elevated Normal or low-normal FSH/LH Low estradiol	Chapter 4
Eating disorders	Low to low-normal FSH/LH Low estradiol Low free T3 (anorexia)	Chapter 4

1. Ovarian failure. Hypergonadotropic hypogonadism, reflecting the inability of the ovary to respond to gonadotropin stimulation, due to follicular depletion ([Chapter 10](#))
2. Central defects. Hypogonadotropic hypogonadism, reflecting hypothalamic or pituitary failure or suppression ([Chapter 10](#))
3. HPO dysfunction, resulting in asynchronous gonadotropin and estrogen production, having a wide variety of causes and clinical manifestations that depend on the level of ovarian function, including amenorrhea ([Chapter 10](#)), hirsutism ([Chapter 12](#)), abnormal uterine bleeding ([Chapter 14](#)), endometrial hyperplasia and cancer ([Chapter 17](#)), and infertility ([Chapter 25](#))

PCOS is the most obvious and common condition associated with chronic anovulation, affecting 4–6% of reproductive-age women, although given changes in diagnostic criteria, the prevalence has doubled.<sup>25,26,27</sup> **It is inaccurate to state that PCOS is the most common “cause” of anovulation, because PCOS does not cause anovulation; rather, anovulation is commonly encountered in women with PCOS.** Several mechanisms are recognized to contribute to the pathophysiology of anovulation in PCOS, operating at every level of the reproductive system. **Although the term PCOS**

**is now firmly established in our scientific and clinical lexicon, it is important to emphasize that PCOS is not a discrete or specific endocrine disorder having a unique cause or pathophysiology; rather, PCOS is a heterogeneous disorder that is best approached as a diagnosis of exclusion. When diagnosed, approach to PCOS requires a systematic elimination of conditions that can masquerade as PCOS and a thought-out management to address both overt symptoms and covert risks that are recognized sequela of this syndrome.**



# POLYCYSTIC OVARY SYNDROME

---

Multicystic or “sclerocystic” ovaries were recognized as early as the mid-18th century but associated primarily with pelvic pain or menorrhagia. In the early 20th century, prevailing hypotheses viewed them as resulting from inflammation due to infection, from congestion due to pressure or partial torsion that disrupted normal blood flow to the ovary, or from dystrophy due to abnormalities in ovarian nutrition.<sup>28</sup>

In 1935, Irving F. Stein and Michael L. Leventhal first described a symptom complex associated with anovulation.<sup>29</sup> Both gynecologists were born in Chicago, both were graduates of Rush Medical College, and both spent their entire professional careers at the Michael Reese Hospital.<sup>30</sup> Stein and Leventhal described seven patients (four being obese) with amenorrhea, hirsutism, and enlarged, PCO. They reported that all seven resumed regular menses and that two became pregnant after bilateral ovarian wedge resection, involving the removal of one-half to three-fourths of each ovary. Stein and Leventhal developed the wedge resection procedure after observing a resumption of menses following ovarian biopsy in several patients with amenorrhea. They speculated that the thickened ovarian capsule prevented follicles from reaching and escaping from the surface of the ovary.

Careful histologic studies of the “Stein-Leventhal ovary” revealed that they had twice the cross-sectional area of normal ovaries, the same number of primordial follicles, double the number of developing and atretic follicles, a 50% thicker and more collagenized tunica, a fivefold thicker subcortical stroma, and a fourfold greater number of hilar cell “nests” than normal ovaries. These studies further suggested that “hyperthecosis,” characterized by an abundance of such nests and a markedly increased stroma, was likely just a later or more advanced stage of a progressive process.<sup>31</sup>

**Because there are many causes of anovulation, there are many causes of PCO.** Any of the causes of anovulation outlined earlier can yield the same or a similar clinical presentation. Furthermore, it is important to note that PCO (as discussed in the next section) can be found in up to a third of normal cycling/ovulating women.<sup>32</sup> **The polycystic-appearing ovaries result from a functional derangement and not from any one specific central or local defect.**

# Diagnostic Criteria for PCOS

It is generally accepted that PCOS is not a specific endocrine disease but a syndrome represented by a collection of signs and symptoms and that no one sign, symptom, or test is diagnostic. Not surprisingly, establishing criteria for diagnosis of PCOS has proven both challenging and controversial.

It has been argued that having a clear and specific definition for PCOS is important because affected women are at increased risk for a variety of problems (infertility, abnormal uterine bleeding, endometrial cancer, obesity, type 2 diabetes mellitus, dyslipidemia, hypertension, and cardiovascular disease), because this diagnosis can have health implications for other family members, and because the need for lifelong treatment may affect access to health care insurance in systems like that in the United States.<sup>33</sup> **One of the advantages to having specific diagnostic criteria for PCOS relates to research, because varying criteria cloud the conclusions and question the generalizability of results from studies involving women who are identified with “PCOS.” Responsibility of clinicians lies well beyond simply assigning a diagnostic label of PCOS; rather, emphasis should be on understanding the underpinnings to the clinical picture and to long-term health implications and consequences of chronic anovulation, so as to effectively address patient needs while minimizing lifetime risks.**

Diagnostic criteria of PCOS have evolved with time, concomitant with advances in our understanding of reproductive medicine and advances in medical technology. The earliest descriptions of the disorder were based on findings of enlarged ovaries, hirsutism, and menstrual dysfunction.<sup>29</sup> The advent and then refining of hormone assays moved the focus to serum gonadotropin and androgen concentrations.<sup>34</sup> More recent advances in ultrasonography and recognition of the importance of insulin resistance in the pathophysiology of PCOS have turned attention to ovarian morphology<sup>34</sup> and to the metabolic accompaniments and consequences of the disorder.

There have been three separate and distinct efforts to establish or refine the diagnostic criteria for PCOS (Table 11.2). The first was a conference sponsored by the National Institute of Child Health and Human Development (NICHD) in 1990, concluding that the major criteria for diagnosis of PCOS (in order of importance) were (1) hyperandrogenism and/or hyperandrogenemia, (2) menstrual dysfunction, and (3) exclusion of other endocrinopathies having a similar clinical presentation.<sup>35</sup> The second was a conference cosponsored by the European Society of Human Reproduction and Embryology (ESHRE) and the American Society for Reproductive Medicine (ASRM), convened in Rotterdam, the Netherlands, in 2003, concluding that diagnosis of PCOS should be based on at least two of the three major criteria: (1) oligoanovulation, (2)

clinical or biochemical signs of hyperandrogenism, and (3) polycystic-appearing ovary(ies) (assessed by ultrasonography, described as an ovarian volume of more than 10 mL<sup>3</sup> and/or more than 12 follicles measuring between 2 and 9 mm in size in at least one ovary; **Figure 11.4**), also excluding other endocrinopathies having a similar clinical presentation.<sup>36,37</sup> The third was a task force appointed by the Androgen Excess and PCOS Society (AE-PCOS) in 2006, concluding that diagnosis of PCOS requires (1) hyperandrogenism (hirsutism and/or hyperandrogenemia), (2) ovarian dysfunction (oligoanovulation or PCO), and (3) exclusion of other androgen excess or related disorders.<sup>38</sup>

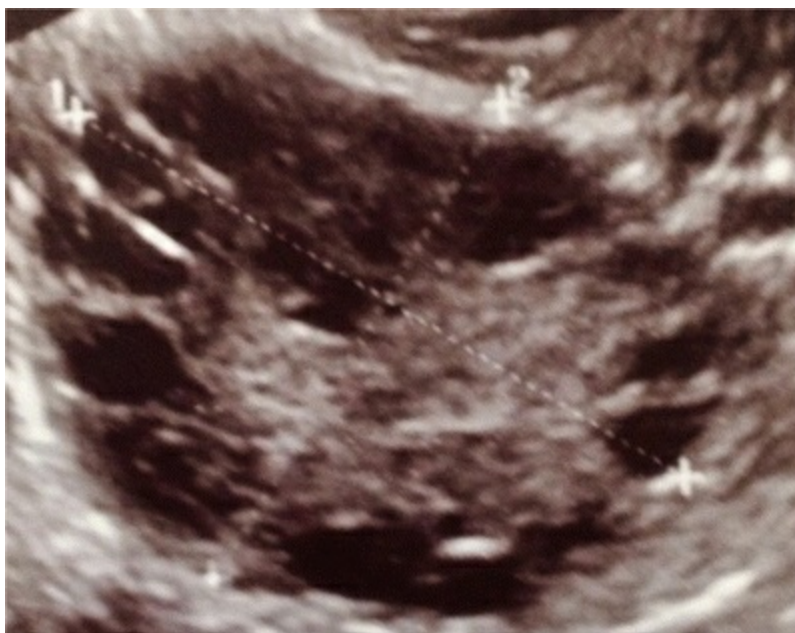
## **TABLE 11.2 PCOS: Diagnostic Classification**

Criteria	National Institute of Health (NIH) Criteria 1990	Rotterdam Criteria 2003	Androgen Excess and PCOS Society Criteria 2006
1 Irregular periods <sup>b</sup>	1 and 2 <sup>a</sup>	Any 2 of 3 <sup>a</sup>	1 and 2 <sup>a</sup>
2 Elevated serum androgens or Hyperandrogenism Hirsutism Acne Androgenetic alopecia			or 2 and 3 <sup>a</sup>
3 Polycystic ovarian morphology (PCOM) or polycystic ovary (PCO) <sup>c</sup>			

<sup>a</sup>Differential diagnoses that can mimic clinical presentation must be excluded.

<sup>b</sup>Eight or less menses per year.

<sup>c</sup>Ovarian volume >10 mL<sup>3</sup> and/or >12 follicles between 2 and 9 mm in size in at least one ovary.



**FIGURE 11.4**

The original 1990 NICHD diagnostic criteria were based on traditional concepts of PCOS, requiring evidence of both hyperandrogenism (hyperandrogenemia and/or hirsutism) and menstrual dysfunction (oligo-/amenorrhea), with or without the presence of PCO. The 2003 ESHRE/ASRM (“Rotterdam”) criteria sought to recognize and accommodate a broader spectrum of the disorder. Given that women need only fulfill two of the three diagnostic criteria, it allows for inclusion of women with regular menstrual cycles and/or women having neither hyperandrogenemia nor hirsutism. The 2006 AE PCOS Society criteria allowed that either menstrual irregularity or polycystic

ovarian appearance be considered as a sign of ovarian dysfunction. However, unlike the Rotterdam criteria, AE-PCOS Society emphasizes the existence of signs or symptoms of hyperandrogenism as a requisite for diagnosing PCOS. Recently, the AE PCOS Society has recommended that threshold for number of small follicles needed for PCO diagnosis be increased from more than 12 to  $\geq 25$ .<sup>39</sup>

Women with the NIH-defined criteria have an increased risk of having reproductive and metabolic disorders (e.g., type 2 diabetes mellitus, obesity, dyslipidemia).<sup>40</sup> Ovulatory women with PCOS more often have a lower body mass index (BMI) and exhibit less severe degrees of hyperinsulinemia and hyperandrogenism than women with the NIH-defined criteria.<sup>41</sup> Oligo-/anovulatory women without clinical or biochemical signs of excess androgens tend to be least affected by the sequela of PCOS.<sup>25</sup>

Recently, antimüllerian hormone (AMH), a member of the transforming growth factor- $\beta$  (TGF- $\beta$ ) superfamily, has been implicated as another potential marker/contributor to PCOS.<sup>42</sup> AMH is produced by granulosa cells, and expression is greatest in the granulosa cells of follicles measuring less than 4 mm (preantral and antral follicles). In women with PCOS, there is an excessive amount of AMH, which is likely explained by increased follicles in the antral and preantral stages, which, as previously mentioned, produce the greatest amounts of AMH.<sup>42</sup> Further studies have also demonstrated that AMH production is increased severalfold in anovulatory PCOS and normo-ovulatory PCOS women when compared to “normal” ovaries, suggesting a dysregulation of the granulosa cells.<sup>42</sup> While the mechanism of increased production is not known, evidence supports a role for androgens, as there is a positive correlation between androgen and AMH levels. Interestingly, AMH also decreases FSH receptor and ovarian aromatase expression. In doing so, it prevents the continued follicular growth and development needed to reach maturity, resulting ultimately in follicular arrest, with no dominant follicle selected.<sup>42</sup> Given these recent findings, AMH has been proposed as an inclusion criterion for the diagnosis of PCOS, likely replacing (or serving as a surrogate for) PCO morphology, as studies have demonstrated that an AMH of 5 ng/mL (using the EIAMH/MIS kit) has a high specificity (97%) and greater sensitivity than the current criteria for PCO morphology.<sup>42</sup> Of note, given no standardization/validation across populations as of yet, exercising caution is recommended before replacing PCO-appearing ovaries on US with AMH level; rather, a threshold of AMH  $\geq 5$  ng/mL may be used as a further suggestion of PCOS, much like the utility of a reversed FSH/LH ratio in serving to suggest ovulatory dysfunction.

The diagnostic criterion most commonly utilized in clinical practice for diagnosing PCOS is the “Rotterdam” criterion.<sup>20</sup> However, the overall prevalence of PCOS among different populations (accounting for the three different diagnostic criteria) is relatively

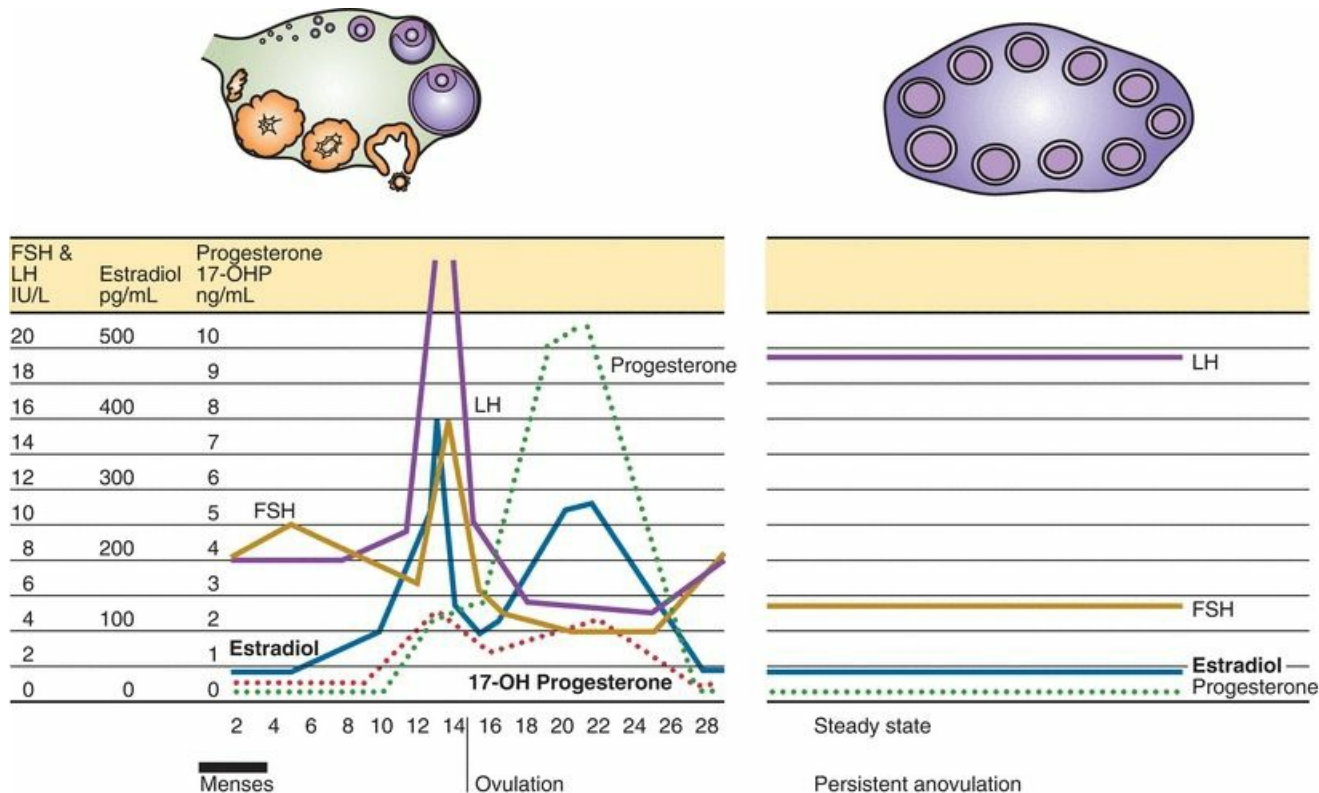
similar (NIH 6%, Rotterdam and AE-PCOS 10%).<sup>43</sup> Regardless of the criteria utilized to diagnose PCOS, it is important to rule out common causes of anovulation ([Table 11.1](#)) and exclude other potential endocrinopathies and conditions that can mimic PCOS (discussed later in this chapter).

# Pathophysiology of Polycystic Ovary Syndrome

Whereas the morphologic characteristics of PCO were attributed at first to pathologic changes in the ovaries themselves that prevented ovulation,<sup>31</sup> they now are recognized as reflecting the disordered endocrine milieu that results from chronic anovulation. In contrast to the cyclic pattern of hormone concentrations that occurs during the normal cycle, the endocrine milieu in women with chronic anovulation is characterized by a “steady state” in which gonadotropin and sex steroid concentrations vary relatively little, by comparison.

The average daily production of both androgens and estrogens is increased in women with PCOS, as reflected by elevated serum concentrations of testosterone, androstenedione, dehydroepiandrosterone (DHEA), dehydroepiandrosterone sulfate (DHEA-S), 17 $\alpha$ -hydroxyprogesterone (17-OHP), and estrone. The results of treatment with a long-acting GnRH agonist (aimed at suppressing gonadotropin-dependent ovarian steroid production) indicate that the increases in serum testosterone, androstenedione, and 17-OHP derive from the ovary and are LH-dependent, whereas those in DHEA and DHEA-S derive from the adrenal.<sup>44,45,46,47</sup> Serum estrone concentrations are modestly elevated, due to peripheral conversion of increased amounts of androstenedione. In contrast, serum estradiol levels in women with PCOS fluctuate but generally remain within the range typically observed in the early follicular phase,<sup>48</sup> reflecting continued low-level production from limited follicular development.<sup>49,50</sup> Unlike the cyclic fluctuations in the HPO hormone concentrations that occur during and are determinants of normal ovulatory menstrual cycles, an altered pattern of gonadotropin secretion, chronic hyperandrogenemia, and insulin resistance (usually, though not always, associated with obesity) all contribute, to varying degrees, to the ovarian dysfunction of PCOS.<sup>25</sup> An altered pattern of GnRH release that leads to an increased LH pulse frequency (as discussed earlier) offers a unifying mechanism for both ovarian androgen excess (due to LH-mediated stimulation of androgen production by ovarian stroma) and impaired follicle development that results in chronic anovulation (due to the relatively low FSH levels that occur secondary to altered GnRH release pattern). The state of hyperandrogenism resulting from ovarian androgen excess in turn contributes to as well as gets further perpetuated by insulin resistance and the resultant hyperinsulinemia. A vicious cascade of events is thus created with insulin excess worsening hyperandrogenism through further ovarian androgen production and also by lowering of hepatic SHBG production. The endocrine milieu in women with PCOS therefore reflects a chronic anovulatory state, which may result from a wide variety of causes (**Figure 11.5**). **Current perspectives view PCOS as a complex disorder, similar to cardiovascular disease and type 2 diabetes mellitus, wherein numerous genetic variants and environmental factors interact, combine, and contribute to the**

**pathophysiology.**<sup>38</sup> In recent years, attention has focused on identifying genetic variants including involved in the regulation of gonadotropin secretion and action, insulin secretion and action, weight and energy regulation, and androgen synthesis and action, which may shed light on causative mechanisms for PCOS.



**FIGURE 11.5**

**Beyond the clinical stigmata of androgen excess and anovulation of PCOS, the hormonal environment sets a stage for a number of metabolic sequelae commonly encountered in women with PCOS and that contribute to lifetime health risks in this population.**

The pathophysiology of PCOS is most likely multifactorial involving endocrine, metabolic, genetic, epigenetic, and environmental factors. The following sections describe how each of the aforementioned factors may be relevant to the pathogenesis of this complex disorder.

## Gonadotropin Secretion and Action

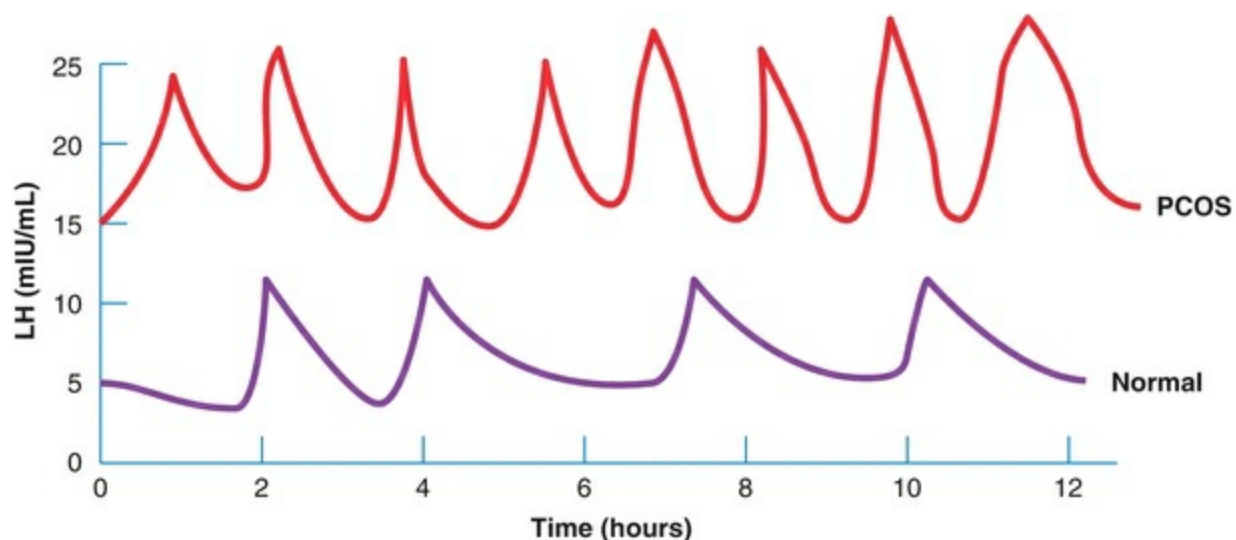
Stein and Leventhal suggested that PCO were likely to result from abnormal anterior pituitary hormonal stimulation,<sup>29</sup> based on earlier observations that treatment with a



urinary extract of anterior pituitary hormones could induce changes similar to those in PCO.<sup>51</sup> Subsequent studies employing an LH bioassay (based on the ovarian response of immature female rats or the prostatic response of hypophysectomized male rats to urinary extracts) demonstrated excessive LH activity in women with PCOS,<sup>52,53,54,55</sup> which later was confirmed by studies using a radioimmunoassay.<sup>56</sup>

**Compared to normally cycling women, those with PCOS generally exhibit increased serum LH concentrations, low-normal FSH levels, and increased LH to FSH ratios.<sup>8,57,58</sup> The increase in serum LH levels results from abnormal LH secretory dynamics, characterized by an increase in LH pulse frequency and, to a lesser extent, also in pulse amplitude.<sup>7,59–61</sup> The decrease in FSH levels results from the increase in GnRH pulse frequency, the negative feedback effects of chronically elevated estrone concentrations (derived from peripheral aromatization of increased androstenedione), and normal or modestly increased levels of inhibin B (derived from small follicles).<sup>62,63</sup>**

LH pulse frequency in women with PCOS does not exhibit the normal cyclic variation seen in ovulatory women (discussed in [Chapter 5](#)) and is relatively constant, at approximately one pulse per hour ([Figure 11.6](#)). This pattern presumably reflects a similar increase in hypothalamic GnRH pulse frequency, which favors secretion of LH more than FSH.<sup>64,65,66</sup> The LH response to an acute exogenous GnRH stimulus also is exaggerated in women with PCOS, but to a lesser extent in the obese than in lean PCOS women; accordingly, LH pulse amplitude and serum LH levels are generally somewhat lower in obese than in lean women with PCOS.<sup>8,67</sup> Elevated serum LH concentrations in women with PCOS also exhibit increased bioactivity in bioassay systems in vitro, reflecting a difference in glycosylation with a predominance of more basic (alkaline) LH isoforms, which have greater bioactivity.<sup>60,68,69,70</sup>



**FIGURE 11.6**

The approximate hourly LH pulse frequency in women with PCOS is within the range of frequencies usually observed in the late follicular phase of a normal ovulatory cycle which favor LH over FSH release ([Chapter 4](#)); these observations imply that the defective mechanism in PCOS appears to lie in the failure of processes that normally slow the GnRH pulse generator rather than resulting from an abnormal acceleration in the GnRH pulse frequency. The increased pulse frequency might reflect an intrinsic hypothalamic dysfunction, the effects of abnormal feedback signals from the periphery, or both.<sup>71</sup>

Since dopamine and opioids normally inhibit hypothalamic GnRH neuronal activity (discussed in [Chapter 4](#)), the higher GnRH pulse frequency observed in women with PCOS may be secondary to a decrease in dopaminergic or opioidergic neuronal signals to the GnRH neurons. However, experimental evidence from studies involving treatment with medications that stimulate or inhibit these pathways does not support either mechanism. Treatment with a dopamine agonist has no discernible effect on the pattern of gonadotropin secretion in women with PCOS.<sup>72,73</sup> Treatment with a progestin slows LH pulse frequency,<sup>74</sup> just as progesterone does during the normal luteal phase, indicating that the opioid-dependent process that normally mediates the effects of progesterone is operating.<sup>75,76,77</sup> While these observations suggest that any alterations in GnRH pulsatility and decrease in opioid tone result primarily from the lack of progesterone feedback, that itself is a consequence of anovulation. However, in a transgenic mouse model in which GnRH neurons were labeled with green fluorescent protein, dihydrotestosterone (DHT) exposure resulted in increased excitatory inputs to GnRH neurons while impairing progesterone inhibition of GnRH pulse firing suggesting a greater complexity to the mechanisms that underlie HPO dysfunction of PCOS.<sup>78</sup>

Infusion of exogenous insulin<sup>79,80,81</sup> and treatments that decrease insulin levels (metformin, thiazolidinediones) have no significant effect on the pattern of LH secretion in women with PCOS.<sup>81,82</sup> LH levels also are lower in obese than in lean women with PCOS, even though insulin levels are higher in the obese.<sup>8,67</sup> These observations suggest that hyperinsulinemia has no significant direct effect on LH secretion. While insulin may not be causative to the hypothalamic-pituitary dysfunction of PCOS, as discussed earlier, insulin however does act synergistically with LH to perpetuate ovarian androgen production; these effects of insulin are mediated via a distinct pathway specific to insulin binding to its own receptor.<sup>83</sup>

Treatment with exogenous estrone does not increase basal or GnRH-stimulated LH concentrations in women with PCOS,<sup>84</sup> and treatment with an aromatase inhibitor does not decrease LH pulse frequency,<sup>85</sup> indicating that increased circulating levels of estrone may exert negative feedback effects on FSH, but probably do not have any important direct influence on LH secretion in women with PCOS. Whereas the lack of progesterone feedback resulting from anovulation undoubtedly contributes to the higher LH pulse frequency,<sup>74</sup> evidence suggests that the GnRH pulse generator also is less sensitive to the feedback inhibition of sex steroids. Treatment with an estrogen-progestin contraceptive or with physiologic doses of exogenous estrogen and progesterone slows LH pulse frequency in women with PCOS, but to a lesser extent than in normal women.<sup>86,87,88</sup> However, after pretreatment with flutamide (an androgen receptor antagonist), the effects of estrogen and progesterone on LH pulse frequency in women with PCOS are the same as in normal women,<sup>89</sup> suggesting that increased circulating androgen levels help to sustain the higher LH pulse frequency observed in women with PCOS by decreasing sensitivity to estrogen and progestin feedback.

Androgens also may contribute more directly to the abnormal pattern of gonadotropin secretion in women with PCOS. Evidence from studies in rats, sheep, monkeys, and women indicates that prenatal exposure to increased androgen concentrations may affect GnRH pulse generator programming, predisposing to an increased pulse frequency and LH secretion.<sup>11,12,90,91,92,93</sup> At least in rodents, prenatal androgen treatment also decreases basal and estrogen-induced hypothalamic progesterone receptor concentrations,<sup>92</sup> offering a mechanistic explanation for how androgens might decrease hypothalamic sensitivity to progesterone feedback, and provides support for a neuroendocrine origin of PCOS. It may be that hyperandrogenemia from any cause, arising during fetal life (maternal hyperandrogenism, classical congenital adrenal hyperplasia [CAH]), adolescence (premature adrenarche, nonclassical CAH), or in adulthood (obesity, hyperinsulinemia), induces abnormalities in the feedback control of pulsatile GnRH secretion, resulting in increased LH secretion, which stimulates increased ovarian androgen production, in a

self-perpetuating cycle.

Studies in rhesus monkeys, which display the most similar HPO axis to humans, have furthered our understanding of the interplay between androgens and gonadotropins and PCOS phenotype. In utero exposure of rhesus fetuses to excess testosterone has resulted in hormonal, reproductive, and metabolic disorders that are reminiscent of PCOS.<sup>93</sup> Following puberty, those animals exposed to excess testosterone in utero displayed LH hypersecretion, ovulatory dysfunction, hyperandrogenism, insulin resistance, and PCO (in 50%). The endocrine and metabolic effects of in utero exposure to excess androgens were also notable in the second-generation female offspring suggesting in utero programming effects.<sup>93</sup> Studies in the nonhuman primate model in particular provide support for a causative role for androgens in altering gonadotropin secretion in PCOS.

The primary evidence indicating that excessive LH stimulation plays an important role in the pathophysiology of PCOS comes from studies examining the effects of treatment with GnRH antagonists and long-acting GnRH agonists. In women with PCOS, treatment with a GnRH antagonist induces an acute dose-dependent decrease in both LH and testosterone concentrations,<sup>61</sup> and long-term treatment with an agonist can suppress ovarian androgen production to postmenopausal levels.<sup>32,94</sup> **These observations suggest that excessive LH secretion or stimulation may be an important cause of disordered follicular development and anovulation, but is not the proximate cause of PCO or of increased ovarian androgen production in women with PCOS.** A reversed FSH/LH ratio (higher LH than FSH levels) is often encountered in women with PCOS (more so in the lean compared to obese populations), and LH/FSH ratios of more than 2–3 are often interpreted to suggest PCOS diagnosis; the reliability of this observation is questionable given that the gonadotropin levels can vary by the gonadotropin assays used and are noninformative in the setting of obesity. **Consequently, gonadotropin levels or ratios are not reliable in helping diagnose PCOS.**

## **Insulin Secretion and Action**

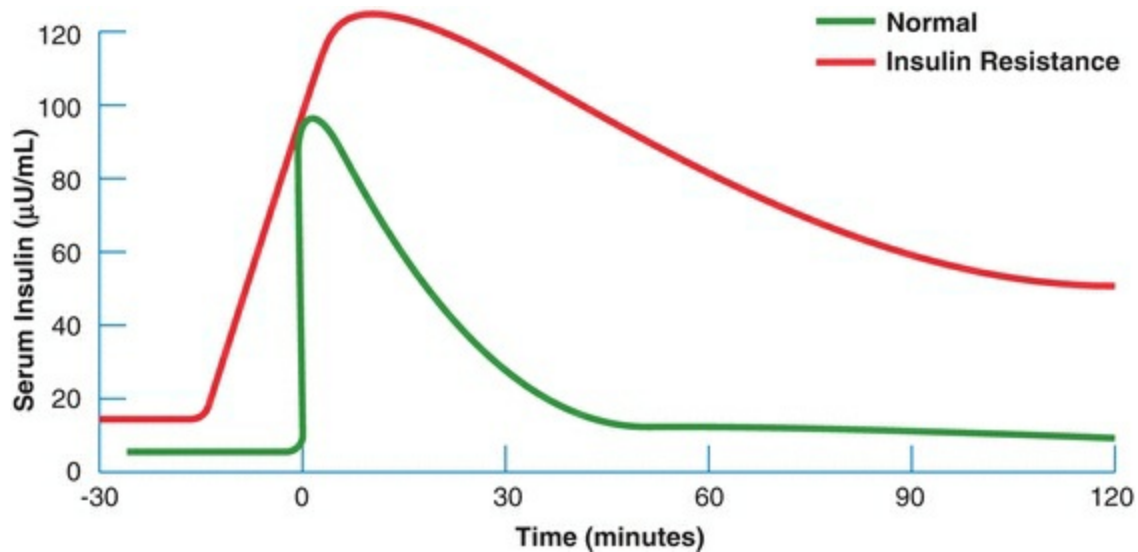
An association between glucose intolerance and hyperandrogenism was first recognized by Archard and Thiers in 1921, in a famous report describing a bearded diabetic woman.<sup>95</sup> Insulin resistance was first described in diabetic patients who required progressively higher doses of insulin to maintain effective glucose control, most often because they developed antibodies to preparations of insulin derived from animal sources.<sup>96</sup> Today, we recognize insulin resistance as a feature of a wide variety of disorders and conditions, ranging from extreme insulin resistance syndromes (autoantibodies to the insulin receptor, insulin receptor mutations, lipodystrophic

states)<sup>97,98,99</sup> to common problems such as type 2 diabetes, obesity, stress, infection, pregnancy, as well as PCOS. The importance of insulin resistance, hyperinsulinemia, and insulin action in the pathogenesis of PCOS was first suggested by a study conducted in 1980, demonstrating significant correlations between basal levels of plasma insulin, androstenedione, and testosterone and between insulin and testosterone levels after an oral glucose load.<sup>100</sup>

**Insulin resistance is a common feature in obese and, to a lesser extent, lean women with PCOS; the overall prevalence ranges between 50% and 75%.<sup>101,102,103</sup>** Insulin sensitivity is decreased by an average of 35–40% in women with PCOS, compared to normal women, similar to what is observed among women with non-insulin-dependent diabetes mellitus.<sup>104,105,106</sup> **Up to 35% of women with PCOS exhibit impaired glucose tolerance, and 7–10% meet the criteria for type 2 diabetes mellitus.<sup>107,108,109</sup>** Conversely, women with type 2 diabetes are sixfold more likely than nondiabetic women of similar age and weight to have PCOS.<sup>110</sup>

**In obese PCOS women, 70–80% are insulin-resistant, while 20–25% of lean women with PCOS are insulin-resistant.**

Insulin resistance is a condition in which endogenously or exogenously administered insulin has less than normal effects on fat, muscle, and the liver.<sup>111,112</sup> In adipose, insulin resistance results in increased hydrolysis of stored triglycerides and elevated circulating free fatty acid levels. Decreased glucose utilization (primarily in muscle) and increased hepatic gluconeogenesis (which insulin normally inhibits) result in increased blood glucose concentrations and a compensatory hyperinsulinemia (in those with adequate pancreatic reserve). Elevated fasting insulin levels are recognized as biochemical evidence of insulin resistance; however, fasting insulin levels may not be consistently elevated in all with insulin resistance. Insulin response to oral glucose load offers meaningful understanding of insulin response, sensitivity, and dynamics. In metabolically normal individuals, following ingestion of 75 g of oral glucose load as utilized for a 2-hour oral glucose tolerance test (OGTT), peak insulin levels are attained within 30 minutes of glucose ingestion and correspond to the first phase insulin release, and insulin levels subsequently decline over the duration of the 2-hour test. In contrast to regularly menstruating women, insulin response in women with PCOS is often exaggerated and prolonged (**Figure 11.7**). **Increased circulating insulin levels cause or contribute to hyperandrogenism in women with PCOS in at least two important ways—by stimulating increased ovarian androgen production and by inhibiting hepatic SHBG production.**



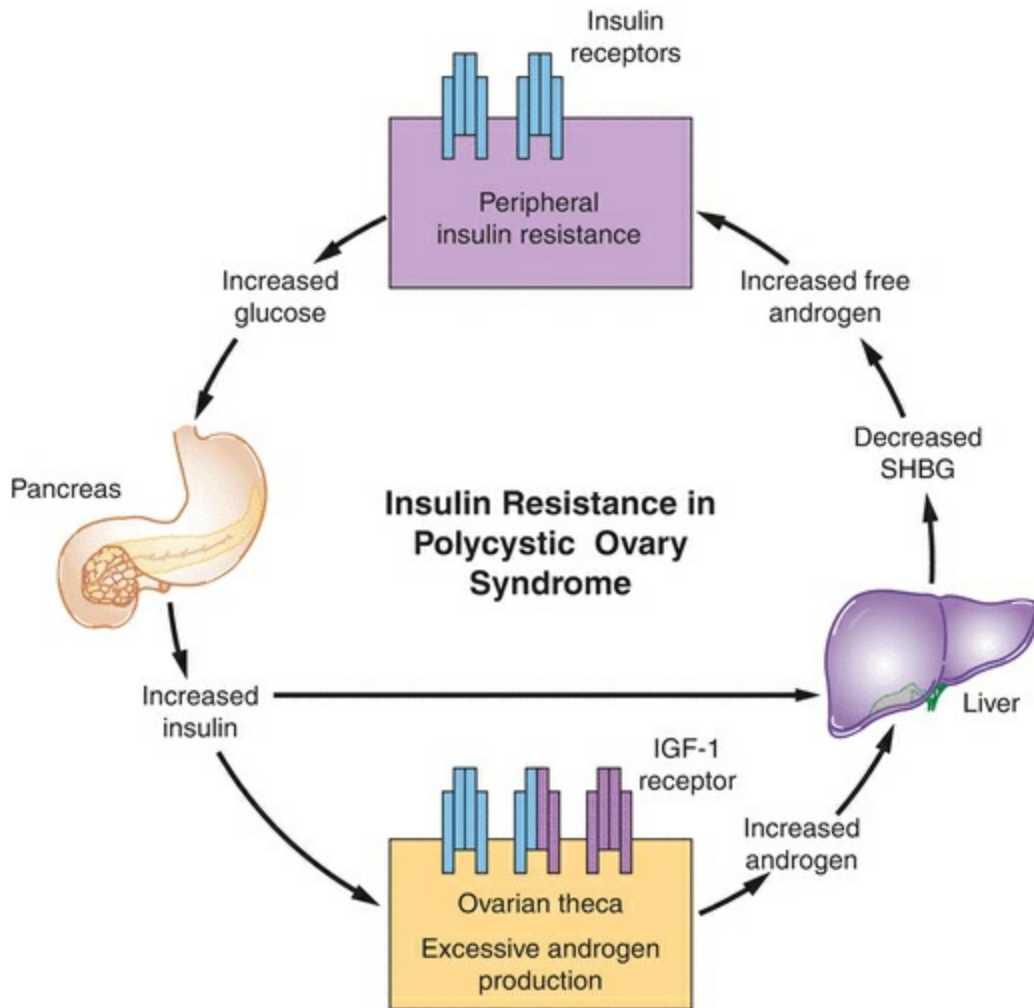
**FIGURE 11.7**

Numerous studies have demonstrated that insulin stimulates androgen production in ovarian theca cells in vitro.<sup>113</sup> Theca cells from women with PCOS also exhibit increased sensitivity to insulin, compared to those from normal women. Physiologic levels of insulin can stimulate androgen synthesis in theca cells of women with PCOS, whereas higher insulin concentrations are required in normal theca cells.<sup>114,115</sup> **Because insulin also potentiates the action of LH,<sup>116</sup> insulin and LH act synergistically to stimulate androgen production.<sup>114,117</sup>**

Clinical investigations in women with PCOS have demonstrated that insulin also stimulates ovarian androgen production in vivo. Notably, the cumulative sum insulin response during an OGTT correlates positively with the rise in serum androstenedione and testosterone above baseline concentrations.<sup>118</sup> Moreover, suppression of serum insulin levels by treatment with diazoxide or an insulin-sensitizing agent (troglitazone) decreases serum androstenedione and testosterone levels in women with PCOS.<sup>119</sup>

High insulin concentrations also inhibit hepatic SHBG production,<sup>120,121</sup> as do high androgen concentrations.

**The combined actions of insulin and androgens lower SHBG concentrations, yielding increased free androgen levels, which aggravate the underlying insulin resistance.<sup>122</sup> Ultimately, these conditions foster a self-propagating positive feedback loop that can increase in severity over time (Figure 11.8).**



**FIGURE 11.8**

Insulin stimulates ovarian androgen production acting via insulin receptors on theca/interstitial cells in the ovarian stroma.<sup>115,123</sup> At high concentrations, insulin also binds to IGF-1 receptors (and possibly hybrid receptors), which are structurally similar and use a similar signaling mechanism.<sup>104</sup> Insulin also acts primarily via its own receptor, by activating a signaling system separate from that involved in glucose transport.<sup>83</sup> Whereas an anti-insulin receptor antibody effectively inhibits insulin-stimulated steroidogenesis in cultured human granulosa cells, an anti-IGF receptor antibody has no effect.<sup>115,124,125</sup> In recent years, two stereoisomers of inositol, D-chiro-inositol and myoinositol, have received increasing attention as possible modulators of insulin signaling in PCOS. In vitro experiments utilizing D-chiro-inositol-containing glycan demonstrated increased theca cell testosterone production, and preincubation with an anti-inositolglycan antibody was shown to block insulin stimulation, but not that of hCG.<sup>115</sup> These observations suggest inositolphosphoglycan mediators act as second messengers in signal transduction for insulin stimulation of theca cell androgen synthesis

and that the mechanism differs from that mediating the actions of LH. Interestingly, treatment of women with PCOS with D-chiro-inositol, with myoinositol, and more recently with a combination of the two stereoisomers in the ratio of 1 (D-chiro-inositol) to 40 (myoinositol) has shown to result in improvements in clinical, endocrine, and metabolic parameters.<sup>126,127,128</sup>

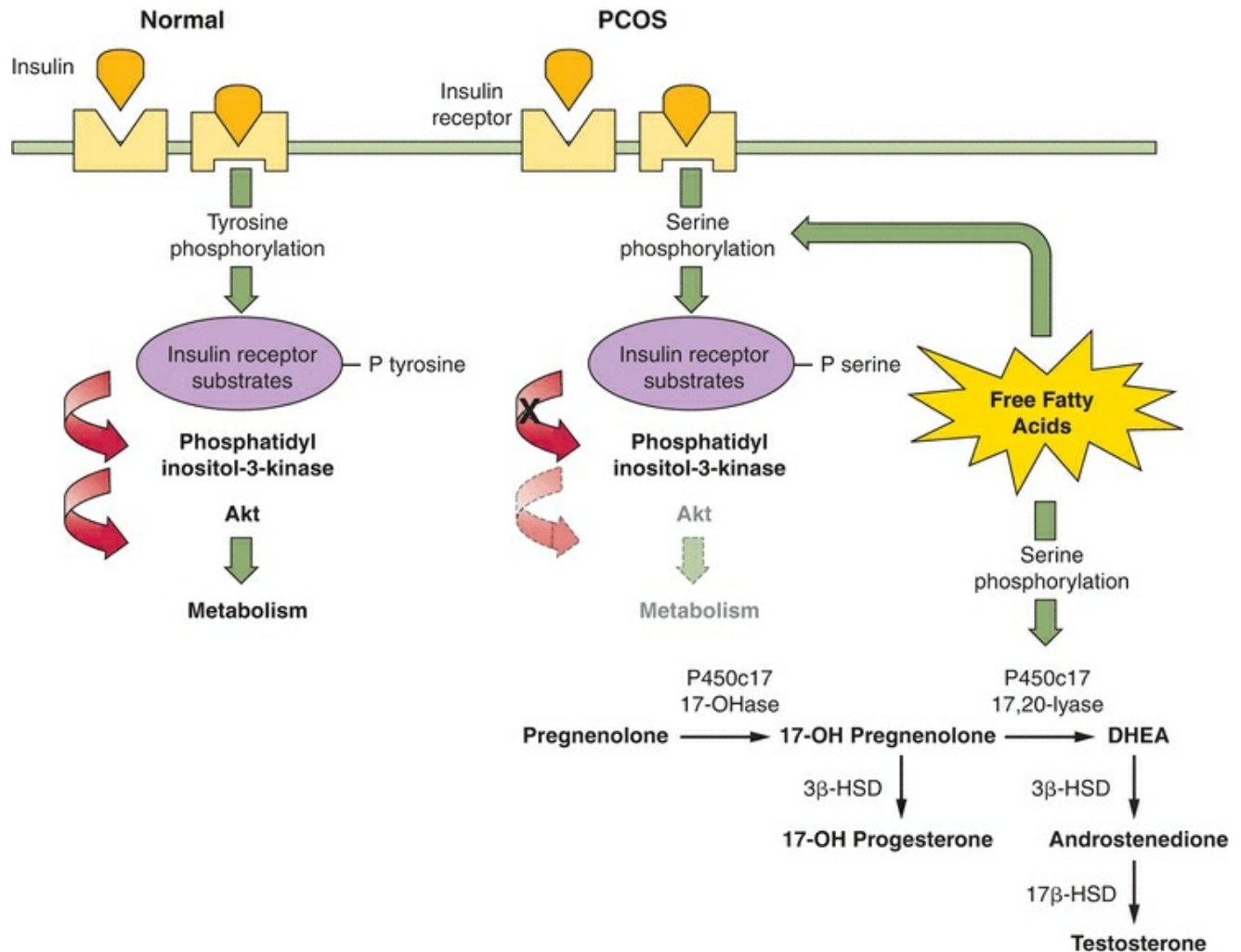
What causes insulin resistance in women with PCOS is not entirely clear. Not surprisingly, given the complexity and polygenic nature of the disorder, evidence suggests that more than one mechanism may be involved.

The classical actions of insulin are mediated via its receptor and two distinct intracellular pathways. The phosphatidyl-inositol 3-kinase (PI-3K) pathway mediates the metabolic effects of insulin, and the mitogen-activated protein kinase (MAPK) pathway mediates the proliferative actions of insulin. Normally, insulin binding to its receptor induces a conformational change, resulting in tyrosine phosphorylation of the receptor and protein substrates, which bind and serially activate PI-3K and Akt, an effector molecule that plays the major role in signal transduction for glucose regulation and metabolism.<sup>129,130</sup> Akt activation potentiates the translocation of glucose transporter 4 (GLUT4) from intracellular compartments to the plasma membrane, thereby increasing glucose uptake. Other effector molecules mediate insulin inhibition of gluconeogenesis and glycogenolysis,<sup>131,132</sup> stimulation of lipid synthesis, and inhibition of lipid catabolism.<sup>133,134</sup> Luteinized granulosa cells obtained from women with PCOS display both a selective increase in insulin activation of the mitogenic pathway, via MAPK, and resistance in the PI-3K-mediated metabolic pathway of insulin action.<sup>135,136</sup> **These and similar observations illustrate how insulin actions can be selectively inhibited and enhanced at the same time, via different signaling pathways,<sup>104,135</sup> explaining how insulin can stimulate hyperandrogenism in women who are “insulin-resistant.”**

Studies in cultured skin fibroblasts, muscles, and adipocytes from women with PCOS indicate that insulin resistance results from defects early in the postreceptor signaling pathway.<sup>106,136,137,138</sup> The number and affinity of insulin receptors in both obese and lean women with PCOS are not decreased,<sup>139,140</sup> but insulin receptors exhibit a constitutive increase in phosphorylation of serine residues and a decrease in insulin-stimulated phosphorylation of tyrosine residues.<sup>129</sup> Serine phosphorylation of insulin receptor substrates prevents their binding with PI-3K and thereby inhibits insulin signaling. Increased serine phosphorylation can be induced by intracellular metabolites of free fatty acids,<sup>138,141</sup> which are increased in most women with PCOS and have been demonstrated to cause insulin resistance in vivo.<sup>142,143</sup> High circulating free fatty acid levels also can increase androgen production in women,<sup>144</sup> by inducing serine phosphorylation of P450c17, which results in increased 17,20-lyase activity (**Figure**



11.9).<sup>145,146</sup> These observations offer a mechanism for insulin resistance that also further helps to explain the link between insulin and hyperandrogenism in women with PCOS.



**FIGURE 11.9**

Although hyperandrogenism can decrease insulin sensitivity, the effect is relatively modest.<sup>122</sup> **Insulin resistance and hyperinsulinemia are the cause, not the result, of hyperandrogenism in PCOS.** Treatment with a GnRH agonist can normalize elevated serum androstenedione and testosterone levels in women with PCOS, but has limited or no effect on insulin resistance.<sup>45,147,148,149</sup> Accumulating evidence suggests that deficiency or dysfunction in downstream signaling mediated by inositol phosphoglycans also may contribute to insulin resistance in women with PCOS.<sup>150,151,152,153</sup> Finally, obesity is a common feature of women with PCOS, representing yet another important mechanism contributing to the development of insulin resistance, as discussed below.

**Insulin resistance and hyperinsulinemia are undoubtedly an important part of**

**the pathophysiology of PCOS. However, it is important to emphasize that 25–50% of women with PCOS have no demonstrable insulin resistance. Moreover, among all women with insulin resistance, the prevalence of PCOS is relatively low (approximately 15%).<sup>154</sup> The prevalence of PCOS is similarly quite low in women with type 2 diabetes mellitus (2.5%).<sup>155</sup> Therefore, insulin resistance and hyperinsulinemia are not the primary cause or pathogenic factor in all women with PCOS.**

## **Obesity, Weight, and Energy Regulation**

The risk for developing PCOS-like picture rises with increasing obesity,<sup>154,156,157</sup> as does the severity of insulin resistance, hyperinsulinemia, and ovulatory dysfunction and the prevalence of metabolic syndrome, glucose intolerance, risk factors for cardiovascular disease, and sleep apnea.<sup>107,158,159,160,161</sup>

Obesity, by itself, is associated with insulin resistance and compensatory hyperinsulinemia. Insulin resistance is most highly correlated with intra-abdominal obesity, because visceral fat is more active metabolically than subcutaneous fat, is more sensitive to lipolysis, releases more free fatty acids, and produces a number of cytokines involved in insulin resistance, such as tumor necrosis factor- $\alpha$  (TNF- $\alpha$ ), interleukin-6, leptin, and resistin.<sup>162</sup> The accumulation of free fatty acids in tissues causes lipotoxicity and insulin resistance, in part via TNF- $\alpha$ , which increases serine phosphorylation and thereby inhibits insulin signaling.<sup>163</sup> Insulin resistance due to obesity also induces leptin resistance and decreases adiponectin levels, thereby decreasing fatty acid oxidation and promoting lipotoxicity.<sup>162,164</sup> Obesity in women with PCOS typically is distributed centrally, with a greater increase in visceral than in subcutaneous fat.<sup>165,166,167,168</sup> However, even lean women with PCOS have an increased percentage of body fat, a higher waist-hip ratio, and greater intra-abdominal, peritoneal, and visceral fat, compared to normal women matched for BMI.<sup>169</sup>

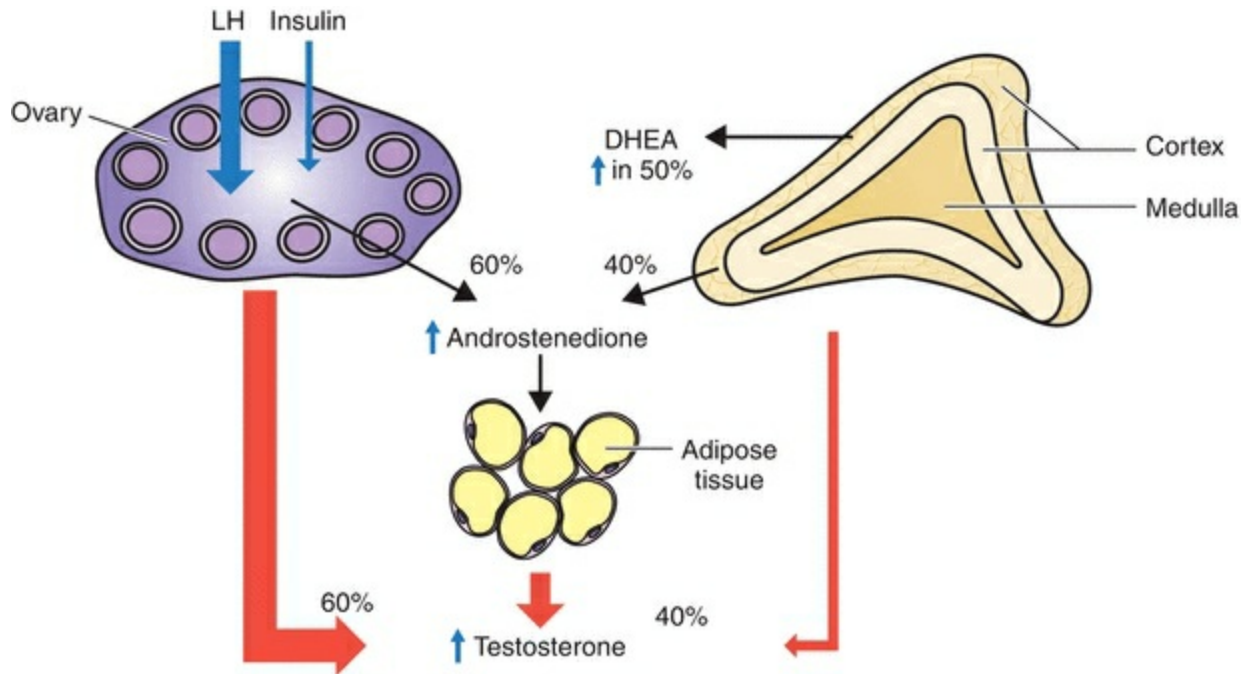
The overall prevalence of obesity, and in women with PCOS, varies among different patient populations<sup>170</sup>; in the United States, approximately 35% of all adult women and 60% of women with PCOS are obese.<sup>171,172</sup> However, the overall prevalence of PCOS among different populations is quite similar (approximately 7%).<sup>27,173,174,175</sup> Moreover, the prevalence of PCOS among unselected women varies relatively little with increasing BMI: 8.2% in underweight women (BMI < 18.5 kg/m<sup>2</sup>), 9.8% in normal-weight women (18.5–24.9 kg/m<sup>2</sup>), 9.9% in overweight women (BMI 25.0–29.9 kg/m<sup>2</sup>), 9.0% in obese class I women (BMI 30.0–34.9 kg/m<sup>2</sup>), 12.4% in obese class II (BMI 35.0 and 40.0 kg/m<sup>2</sup>), and 11.5% in obese class III or morbidly

obese women (BMI > 40.0 kg/m<sup>2</sup>).<sup>176</sup> **It is important to appreciate that obesity in itself can contribute to a PCOS-like picture given the HPO dysfunction resulting from obesity-related alterations in hypothalamo-pituitary function and hyperandrogenism resulting from an elevation in free testosterone levels due to suppressed hepatic production of SHBG.** The high androgen levels and chronically elevated estrogen levels (derived from aromatization of androgens in the adipose tissue) sustain or even perpetuate an abnormal pattern of gonadotropin secretion by increasing LH pulse frequency and amplitude and inhibiting FSH secretion. The prevalence of menstrual irregularity, dysfunctional bleeding, hirsutism, and infertility is higher in obese than in lean women with PCOS,<sup>177,178,179</sup> and obesity is an independent risk factor for developing glucose intolerance and diabetes.<sup>107,180</sup>

**Combined, these observations indicate that obesity relates primarily to genetic and environmental factors and is a common, but not essential, feature of PCOS. Obesity contributes modestly to the risk for developing PCOS and adds to the pathophysiology in already affected women by aggravating the degree of insulin resistance and hyperinsulinemia.**<sup>177,181</sup> While it is plausible that PCOS itself may, to some degree, predispose to weight gain and obesity, evidence-based support for such a directionality of association is presently lacking. **Obese women have a higher prevalence of miscarriage, gestational diabetes, and pre-eclampsia, regardless whether they also have PCOS.**<sup>182</sup>

## **Androgen Synthesis and Action**

**Hyperandrogenism is the key feature of PCOS, resulting primarily from excess androgen production in the ovaries and, to a lesser extent, in the adrenals as well as in excess body fat (Figure 11.10).**<sup>183</sup> In women with PCOS, approximately 60% of circulating androstenedione derives directly from the ovaries and the remainder from the adrenals; similarly, 60% of circulating testosterone is secreted directly by the ovaries, with most of the remainder deriving from peripheral conversion of androstenedione.<sup>184</sup>



**FIGURE 11.10**

The primary mechanisms driving increased ovarian androgen production in PCOS include increased LH stimulation resulting from abnormal LH secretory dynamics and increased LH bioactivity and hyperinsulinemia due to insulin resistance, which potentiates the action of LH and is worsened by obesity. Other evidence indicates that increased ovarian androgen synthesis in women with PCOS probably also relates to the increased volume of theca cells in an expanded ovarian stroma, which ultimately respond to the excess LH secretion, further perpetuating ovarian androgen production.<sup>25,185,186,187</sup> Androgen production remains elevated in long-term cultures of theca cells from women with PCOS,<sup>188</sup> even after suppression of LH levels by treatment with a GnRH agonist,<sup>189</sup> suggesting that increased androgen production in women with PCOS, to some extent, also reflects an intrinsic dysregulation of key steroidogenic enzymes, such as  $3\beta$ -hydroxysteroid dehydrogenase ( $3\beta$ -HSD) and 17,20-lyase,<sup>114,185,190,191,192</sup> which may have a genetic foundation.<sup>193</sup>

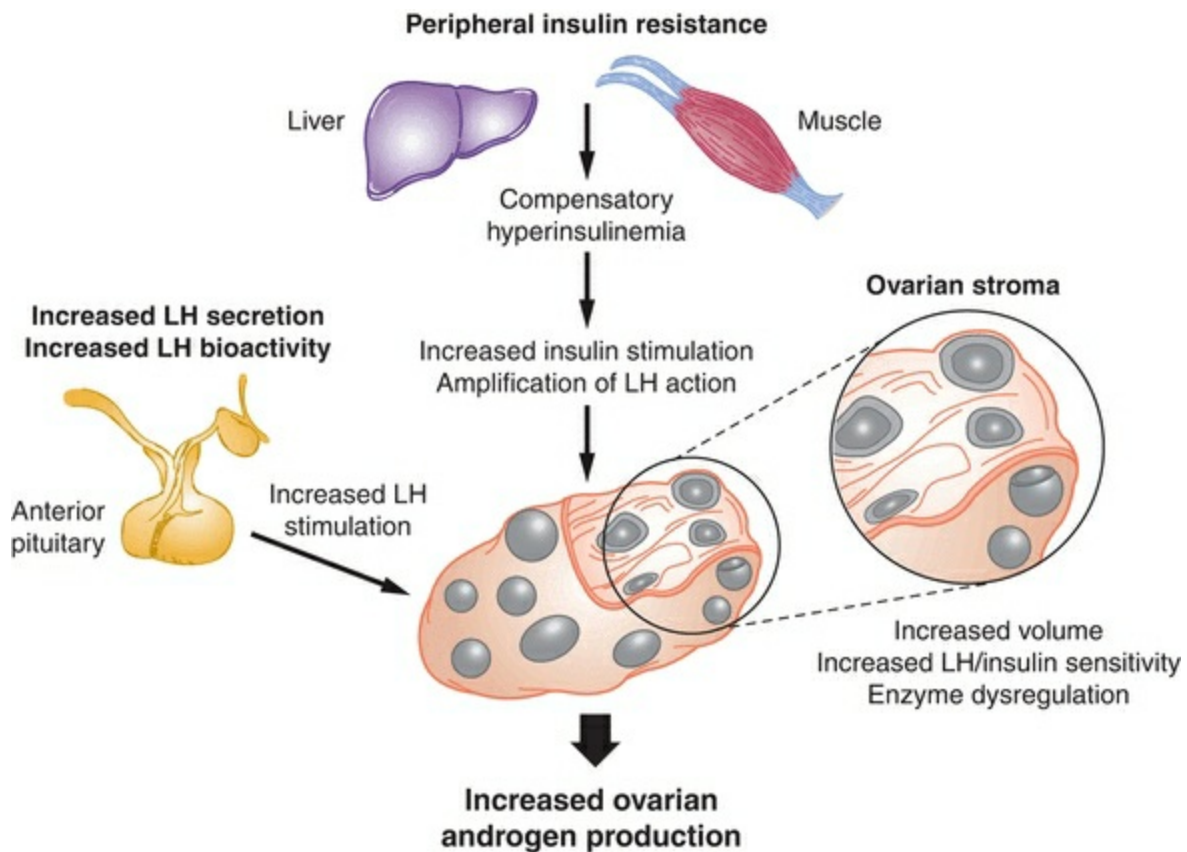
**Adrenal androgen production (androstenedione, DHEA, DHEA-S) also is increased in women with PCOS; over half exhibit moderately increased circulating DHEA-S levels.**<sup>194</sup> When ovarian synthesis is suppressed by treatment with a long-acting GnRH agonist, adrenal androgen levels remain higher in women with PCOS than in normal women.<sup>101,185,189,195</sup> Adrenal androgens have little or no intrinsic androgenic activity, but contribute to the pathophysiology of PCOS via conversion to testosterone in the periphery (discussed in [Chapters 12](#) and [13](#)).

A number of potential mechanisms for the increase in adrenal androgen production have been investigated, but the explanation remains uncertain. Chronic estrogen stimulation due to anovulation could decrease adrenal  $3\beta$ -HSD activity, as it does in the fetal adrenal cortex, but evidence for this mechanism is conflicting.<sup>196,197,198,199,200</sup> Increased pituitary ACTH secretion or increased sensitivity to ACTH could provide an explanation, as 30–50% of women with PCOS show increased 17-ketosteroid response to ACTH.<sup>201,202</sup> In some, but clearly not all, women with PCOS, adrenal androgen excess might result from intrinsic upregulation of P450c17 17,20-lyase activity<sup>47,146,203,204,205</sup> or from hyperinsulinemia.<sup>206,207,208,209,210</sup> **In sum, no one mechanism explains the moderate adrenal androgen excess commonly observed in women with PCOS.**

High local androgen concentrations contribute to the polycystic morphogenesis of the ovaries, via conversion to more potent  $5\alpha$ -reduced androgens, which cannot be aromatized to estrogen and inhibit both aromatase activity and FSH induction of LH receptors on granulosa cells, thereby impeding or preventing progressive follicular development. Granulosa cells obtained from PCO are not functionally impaired. They are sensitive to FSH and insulin-like growth factors and produce estrogen,<sup>211,212,213,214</sup> but cannot generate and maintain the estrogenic follicular milieu required to achieve more advanced stages of development. Consequently, new follicular growth continues but arrests long before full follicle maturation is achieved, resulting in multiple small follicular cysts (typically measuring 2–10 mm in diameter), surrounded by hyperplastic theca cells, which often become luteinized due to increased LH stimulation. Atretic follicles ultimately contribute to an expanding ovarian stroma that increases in volume over time, further increasing the cellular mass that contributes to producing androgens; the net result is a self-propagating cycle that predisposes to chronic anovulation.

Further evidence for a pathogenic role of androgens as causative to impaired follicular growth in PCOS comes from literature on ovarian surgical procedures, similar to concepts first proposed by Stein and Leventhal, which are aimed at reducing ovarian theca cell volume as a mechanism for restoring spontaneous ovulation. Ovarian wedge resection as first described by Stein and Leventhal, although no longer regularly performed, provided evidence of the important contributions of ovarian tissue to the pathophysiology of PCOS. The success of ovarian wedge resection correlated with the amount of androgen-producing stromal tissue that is removed, and wedge resection results in a sustained decrease in androgen levels that precedes the return of ovulatory cycles, indicating that high intraovarian androgen concentrations effectively inhibit follicular development and prevent ovulation.<sup>215,216,217,218</sup> Even a unilateral oophorectomy can restore menstrual cyclicality and ovulation in anovulatory women with PCO.<sup>219</sup> Although laparoscopic procedures such as ovarian “drilling” with an

electrosurgical needle or a laser have replaced the classical wedge resection, the results achieved are similar, albeit lesser lasting in longevity. PCO also have been observed in women with androgen-producing ovarian and adrenal tumors<sup>220,221,222</sup> and in female-to-male transsexuals treated with exogenous androgens.<sup>223,224</sup> **These observations again illustrate the important point that PCO are not a characteristic feature of a specific endocrine disorder. They result from a functional derangement in follicular development induced or sustained by increased intraovarian androgen levels and represent a consequence of chronic anovulation, whatever the cause (Figure 11.11).**



**FIGURE 11.11**

## Genetic Considerations

Familial clustering of hyperandrogenism, anovulation, and PCO suggests an underlying genetic basis or cause. At least one group of patients with a heritable X-linked form of PCOS has been described, albeit with a widely varying phenotype.<sup>213</sup> Studies in large families have suggested autosomal dominant inheritance, with premature balding as the male phenotype.<sup>225,226</sup> Other studies of siblings and parents of women with PCOS have

observed a high prevalence of hyperinsulinemia and hypertriglyceridemia, PCOS in females, and premature balding in males.<sup>227,228</sup> Nearly 50% of sisters of women with PCOS have elevated total or bioavailable testosterone concentrations,<sup>229</sup> and approximately 35% of mothers also are affected.<sup>230,231</sup> The first-degree relatives of women with PCOS also exhibit other metabolic abnormalities such as dyslipidemia, which may predispose to an increased risk for cardiovascular disease.<sup>35,157,232,233</sup> These observations further suggest a genetic predisposition or susceptibility.

Understandably, efforts to identify genes associated with a susceptibility to anovulation and PCO have focused on genes relating to the insulin receptor and substrates<sup>225,226,227</sup> and the genes encoding the P450 side-chain cleavage (CYP11) and P450c17 (CYP17) enzymes and SHBG and FSH receptors.<sup>234,235,236,237,238,239</sup> Ongoing genome-wide association studies (GWAS) have begun to identify several possible candidate genes, including the DENND1A (differentially expressed in normal and neoplastic cell domain-containing protein 1A) and THADA (thyroid adenoma-associated protein) genes.<sup>108</sup> Further support for DENND1A comes from studies demonstrating increased levels of the V2 isoform of DENND1A in theca cells obtained from women with PCOS.<sup>240</sup> Functional genomic studies are also underway, as are research aimed at understanding the role epigenetics/altered DNA methylation plays in PCOS.<sup>25</sup> **Currently, PCOS is best seen as a polygenic disorder involving the interaction of numerous genomic variants and the influence of environmental factors.**<sup>234,235,236,237,238,241</sup> Candidate genes include the long list of molecules that participate in any of the metabolic and reproductive pathways affected in the syndrome, emphasizing yet again that PCOS is not a specific endocrine disorder, but a result of chronic anovulation due to a wide variety of causes (Table 11.3).<sup>242</sup>

## TABLE 11.3 Genetics of PCOS

<b>Genes</b>	<b>Chromosome</b>	<b>Function</b>
LHCGR	Chromosome 9	Gonadotropin action
FSHR	Chromosome 2	Gonadotropin action
THADA	Chromosome 2	Apoptosis
DENND1A	Chromosome 2	Endocytosis, receptor-mediated turnover
YAP1	Chromosome 11	Cell proliferation
GATA4	Chromosome 8	Transcription factor
C9orf3	Chromosome 9	Aminopeptidase
HMGA2	Chromosome 12	Transcriptional regulating factor
TOX3	Chromosome 16	Chromatin remodeling
INSR	Chromosome 19	Insulin signaling
SUMO1P1	Chromosome 20	Cell proliferation
KCNA4/FSHB	Chromosome 11	Gonadotropin action
ERBB4	Chromosome 2	Mitogenesis and differentiation
RAD50	Chromosome 5	DNA repair
KRR1	Chromosome 12	Ribosome biogenesis
RAB5B, SUOX	Chromosome 12	Protein transport, breakdown



Adapted from **Liu H, Zhao H, Chen ZJ**, Genome-wide association studies for polycystic ovary syndrome, *Semin Reprod Med* 34:224, 2016.

# Diagnosis of Polycystic Ovary Syndrome

It is generally accepted that PCOS is not a specific endocrine disease but a syndrome represented by a collection of signs and symptoms and that no one sign, symptom, or test is diagnostic. The individual biochemical, clinical, and radiologic components of the commonly utilized diagnostic criteria that were briefly presented earlier (Table 11.2) are discussed in some detail as under.

## Hyperandrogenemia

Testosterone is the most important androgen produced by the ovary, and evidence of circulating levels of total and/or free testosterone above the normal range specified for testing laboratory is the usual basis for diagnosis of hyperandrogenemia. Other androgens that may be elevated in women with PCOS include androstenedione, DHEA, and DHEA-S (further discussed in Chapters 12 and 13).

Testosterone levels are elevated in most, but not all, women with PCOS. The free testosterone level is more sensitive for diagnosis of hyperandrogenic disorders,<sup>38</sup> but measurements of free testosterone have several limitations. Direct radioimmunoassays (RIA) for free testosterone are highly inaccurate,<sup>243,244,245</sup> particularly in the lower range and in women with decreased SHBG levels.<sup>246</sup> More sophisticated and accurate methods (equilibrium dialysis, gas or liquid chromatography-mass spectrometry) are technically complex, costly, and not widely available.<sup>247</sup> Moreover, testosterone is converted in androgen-sensitive tissues by enzyme 5- $\alpha$  reductase to dihydro testosterone (DHT), which has a longer duration of action and greater potency than testosterone, so serum total testosterone concentrations do not necessarily reflect androgen bioactivity at the tissue level. Elevations in circulating total testosterone levels can accompany the LH surge, and thus if feasible, testing should be performed in the follicular phase of menstrual cycle.<sup>93,108</sup>

For purposes of clinical research, the free testosterone concentration can be calculated, using equations derived from the laws of mass action; the serum concentrations of total testosterone, SHBG, and albumin; and the association constants for the interactions of testosterone with SHBG and albumin.<sup>244,248</sup> Calculated values generally correlate well with those determined by equilibrium dialysis,<sup>243,244</sup> although accuracy varies with the specific assays used to measure total testosterone and SHBG. **For clinical purposes, measurement or calculation of the free testosterone level, or even measurement of the serum total testosterone concentration, usually is unnecessary.**<sup>249</sup> In most cases, clinical evidence of hirsutism (discussed in Chapter 12) provides ample evidence of hyperandrogenism, and if not severe, sudden in

**onset, rapidly progressive, or associated with symptoms or signs of virilization, there is little reason for concern about an androgen-producing tumor (Chapter 13).**

Measurement of the serum androstenedione concentration could yield evidence of hyperandrogenemia, but limited data suggest that levels are elevated in less than 20% of women with PCOS.<sup>26</sup> Measurement of serum DHEA also has little or no diagnostic value because levels are relatively low, exhibit a diurnal pattern and high between-subject variability, and are sensitive to stress.<sup>38,250</sup>

The serum DHEA-S concentration is the traditional marker for adrenal androgen excess,<sup>251,252,253</sup> because it derives almost exclusively from the adrenal,<sup>254,255,256</sup> and concentrations are relatively high and remain stable across the day and cycle.<sup>257,258</sup> Overall, the serum DHEA-S concentration is moderately elevated in over half of women with PCOS.<sup>194</sup> Some have an isolated increase in serum DHEA-S, suggesting a deficiency in 3 $\beta$ -HSD, but no genetic mutation in the enzyme has been found.<sup>259,260</sup> DHEA-S, similar to DHEA and androstenedione, has little or no intrinsic androgenic activity and requires conversion to testosterone to exert androgenic effects. **The AE-PCOS Society regards an elevated serum DHEA-S level as sufficient evidence of hyperandrogenism to support the diagnosis of PCOS<sup>44</sup>; serum DHEA-S levels are however not considered when diagnosing PCOS per the Rotterdam criteria. Clinical utility of routine testing of DHEA-S levels in settings of mild clinical hyperandrogenism is limited.** While, intuitively, information on DHEA-S can allow interpretation of adrenal contribution to hyperandrogenemia, this test is limited in both sensitivity and specificity for identifying women with adrenal causes of hyperandrogenism.<sup>256</sup> Although DHEA-S concentrations can be grossly elevated ( $\geq 700$  mg/dL) in women with rare androgen-secreting tumors, however, in almost all such patients, serum testosterone levels are also greatly elevated,<sup>261</sup> due to peripheral conversion of high circulating DHEA-S levels or because the tumor also secretes testosterone.

## Clinical Hyperandrogenism

Clinical manifestations of hyperandrogenism include hirsutism (discussed in detail in Chapter 12), acne, and androgenic alopecia, all of which relate to the effects of androgens on the pilosebaceous unit. Because the sensitivity of the pilosebaceous unit varies significantly among individuals, the correlation between these clinical features and biochemical measures of hyperandrogenism is relatively poor.<sup>262,263</sup>

**Hirsutism is the growth of terminal hairs on the face or body in a male pattern and a distressing symptom of PCOS.** As discussed in Chapter 12, the prevalence as well as severity of hirsutism can vary by race and ethnicity. Correlation of the severity

of hirsutism with hyperandrogenemia is, if at all, modest as circulating androgen levels do not capture the tissue activity of enzyme 5- $\alpha$  reductase that brings about the conversion of testosterone to the more potent androgen, DHT. **The modified Ferriman-Gallwey score is the accepted standard for assessing the severity of hirsutism in clinical investigations (discussed in Chapter 12), and this should be performed in conjunction with asking patients the method and frequency of hair removal (e.g., shaving, plucking, waxing), which also provides a clinically relevant measure for assessing the response to treatment.**

Acne is the second most common manifestation of hyperandrogenism in women with PCOS. Androgen-mediated stimulation of sebaceous secretions is recognized as a mechanism for acne, and in general, across all ages, males have a higher prevalence and severity of acne compared to women. Like hirsutism, the prevalence of acne among women with PCOS varies with ethnicity, ranging from 12% to 14% among White women with PCOS,<sup>171,173,264</sup> being higher in Asian Indians and women of Mediterranean descent (approximately 25%)<sup>264,265</sup> and lower among Pacific Islanders. Overall, among adult women with PCOS, the prevalence of acne ranges between 15% and 95%.<sup>266,267</sup> However, it is unclear whether acne is any more prevalent among women with PCOS than in the general population as approximately 6–55% of adult women acknowledge experiencing acne.<sup>266,268,269,270,271,272</sup> Although association between acne and hyperandrogenemia is described, existing data are equivocal. Excess local production of androgens within the skin due to overactivity of tissue-specific enzymes<sup>273</sup> may be a contributory mechanism, particularly in women with normal circulating androgen levels.<sup>274,275</sup> The extent to which PCOS may increase the risk for developing acne, if at all, is uncertain; however, the stress and psychological burden that acne can impose on the affected individual are real.<sup>276,277,278</sup> Counting of actual acne lesions was first described in 1966 as an approach to assessing efficacy of intervention,<sup>279</sup> and a number of nomenclatures have been examined with little consensus as regards superiority of any one tool in clinical practice.<sup>280</sup> Despite the prevalence as well as health care burden related to acne bother, there is no existing standardized methodology for quantifying severity of acne in women with PCOS. In the clinical setting, quantification of acne severity should take into consideration the number, distribution, and severity of the active lesions as well as residual scars. Pictorial records of the affected areas can allow comparative assessment of response to treatment (**Figure 11.12**).



**FIGURE 11.12**

**Androgenic alopecia** (also called androgenetic alopecia and female pattern hair loss), describing scalp hair loss in women (discussed in [Chapter 12](#)) is a recognized albeit relatively uncommon feature of PCOS.<sup>171,281,282,283,284</sup> In the normal hair cycle, the growth (anagen) phase lasts 2–3 years, accounting for up to 90% of the scalp hair. In situations of chronic androgen excess, hair follicles shrink in the anagen phase, leading to less scalp coverage and alopecia.<sup>285</sup> In a cross-sectional study of 254 women meeting Rotterdam criteria for PCOS, androgenetic alopecia was noted in 22% based on evidence of miniaturization of scalp hair.<sup>286</sup> Although the prevalence of androgenetic alopecia was higher in women with clinical or biochemical evidence of hyperandrogenism (24% vs. 5%,  $p = 0.05$ ), on adjusted analyses, neither androgens nor metabolic parameters are related to the presence of androgenic alopecia. In another cross-sectional study of 263 women diagnosed with PCOS by the Rotterdam criteria (of these, 74% also met the NIH diagnostic PCOS criteria), 27% of the population acknowledged symptom of scalp hair thinning; while no relationship was observed between hair thinning with hyperandrogenism or hyperandrogenemia, lifestyle and biochemical predictors of hair thinning were apparent as those acknowledging scalp hair thinning were significantly more likely to manifest abnormalities in glucose homeostasis.<sup>287</sup> Given that 25% or more of scalp hair must be lost before thinning becomes apparent, the actual prevalence of alopecia may be higher.<sup>171,288</sup> The pattern of hair loss in women with PCOS follows the well-recognized “female hair loss” phenotype wherein hair thinning is most apparent at the caput while the frontal hairline remains well preserved; when more severe, the frontal and bitemporal hair line can be involved<sup>285</sup> ([Figure 11.13](#)).



**FIGURE 11.13**

Overall, the mechanisms of scalp hair loss in women with PCOS remain poorly understood, and there appears to be no relevance of hyperandrogenemia to alopecia of PCOS.

## **Ovulatory and Menstrual Dysfunction**

Normal cyclic menses result from normal ovulatory function (discussed in [Chapter 5](#)). The normal intermenstrual interval ranges between 21 and 35 days. Menses that occur less or more often are an indication of ovulatory dysfunction.<sup>108</sup> Oligomenorrhea is defined as less than eight menstrual cycles per year. Cyclic menses occurring at normal intervals strongly suggest, but cannot be regarded, as proof of ovulation.

The majority of women with PCOS, approximately 60–85%, exhibit obvious menstrual dysfunction.<sup>25,38,170,173</sup> The most common menstrual abnormalities in women with PCOS are oligomenorrhea and amenorrhea. Polymenorrhea (regular cycles occurring at intervals <21 days) is quite uncommon, observed in less than 2% of the PCOS population.<sup>171</sup> Classically, menstrual dysfunction of PCOS can be dated back to onset of menarche in many, although it is not uncommon for the cycles to be regular for varying intervals preceding the onset of oligo-/amenorrhea.

In general, anovulation is accompanied by menstrual irregularity and anovulatory women seldom report regular menses.<sup>289</sup> However, regular cycles are somewhat more common in anovulatory hyperandrogenic women.<sup>38,290</sup> In studies of menstrual function in women with hyperandrogenism, 15–20% are eumenorrheic, despite evidence of oligoanovulation.<sup>108,291,292,293,294</sup> The prevalence of eumenorrhea among women with PCOS is significantly increased if the data in Rotterdam diagnostic criteria are applied,

because hirsute eumenorrheic women with PCO are included. The absence of any recognizable pattern of premenstrual molimina suggests anovulation in eumenorrheic women; confirmation of this impression requires objective some form of assessment, such as laboratory data and/or ultrasound imaging.

## Polycystic Ovaries

The syndrome takes its name from the enlarged polycystic-appearing ovaries that are so commonly observed in women with hyperandrogenic chronic anovulation.<sup>29</sup> Observations of mild hyperandrogenemia and insulin resistance in some asymptomatic women with PCO provided the rationale for including PCO among the Rotterdam diagnostic criteria for PCOS, as a sign of ovarian dysfunction.<sup>295,296,297,298,299</sup>

When defining PCO in PCOS, it is not sufficient to simply note the multiple follicles. Rather, in addition to the multiple small follicles, the ovaries of women with PCOS also exhibit increased size and stromal volume as well as a classic topographic relationship between the follicles and the stroma. The many small follicles are displaced peripherally and surround the dense central stroma of a polycystic ovary (**Figure 11.5**). The Rotterdam consensus criterion for an ovary to be considered polycystic weighs equally on the ovarian volume ( $>10 \text{ mL}^3$ ) and the total number of small follicles measuring between 2 and 9 mm in size ( $\geq 12$ ); presence of any one of these two morphologic ultrasonographic findings in a single ovary serves as meeting the Rotterdam criteria for polycystic ovary.<sup>36,300,301,302</sup> The prevalence of PCO is quite high among women with androgen excess ( $>80\%$ ).<sup>291,303,304,305,306,307,308,309</sup> **However, as mentioned earlier, up to a third of regularly menstruating normal women without PCOS, and even 14% of women using oral contraceptives, also meet the ultrasonographic criteria for PCO.**<sup>32,296,301,310,311,312,313</sup> Moreover, PCO are commonly observed during normal pubertal development and even in women with hypothalamic amenorrhea and hyperprolactinemia.<sup>314,315</sup> Thus, while the finding of polycystic-appearing ovaries alone is of little clinical significance, the inclusion of this ovarian appearance as one of the diagnostic features of PCOS per Rotterdam criteria has expanded the population of women that might be assigned a diagnosis of PCOS by approximately 50%, compared to the criteria earlier recommended by the NICHD, due entirely to the inclusion of PCO.<sup>316</sup> **Otherwise normal women with PCO generally have regular menstrual cycles, exhibit normal serum gonadotropin and ovarian steroid hormone levels, and are not infertile.**<sup>295,311,317,318,319</sup> As mentioned earlier, the AE-PCOS Society has recommended that in order to characterize ovarian appearance as PCO, the minimal number of small follicles should be increased from a threshold of 12, as is specified by Rotterdam criteria, to a minimum of 25.<sup>39</sup>

**Again, the important point is that PCOS is a functional disorder in which PCO result from chronic anovulation. Although present in most women with chronic hyperandrogenic anovulation, PCO do not establish and are not required for diagnosis of PCOS.** [175,195,310](#)



# Common Accompaniments to Polycystic Ovary Syndrome

In addition to the chronic anovulation, hyperandrogenism, hyperandrogenemia, and PCO, which are recognized as hallmarks of PCOS, certain perturbations in physiology are often encountered in women with PCOS but are not included in any diagnostic criteria; these include a reversed circulating FSH/LH ratio that is reflective of abnormal patterns of gonadotropin secretion, clinical and/or biochemical evidence of insulin resistance, and related metabolic abnormalities, such as abnormalities in glucose homeostasis, dyslipidemias, and a generalized proinflammatory state, which collectively reflect an exaggerated cardiometabolic risk profile ([Table 11.4](#)).

## TABLE 11.4 Common Metabolic Abnormalities in PCOS

Metabolic Abnormality	Health Implications	Screening	Management Considerations
Abnormalities in glucose homeostasis	Type II diabetes Risk for CVD Risk for endometrial hyperplasia	OGTT HbA1c Fasting or OGTT provoked insulin levels	Weight reduction Exercise and dietary modifications Insulin sensitizers Incretins Insulin
Lipid abnormalities	Risk for CVD Stroke risk	Fasting lipid profile	Weight reduction Dietary modifications Exercise Lipid-lowering agents Low-dose aspirin
Inflammation	Risk for CVD	Cardio CRP	Weight reduction Dietary modifications Exercise Lipid-lowering agents Low-dose aspirin
Metabolic syndrome	Exaggerated risk for CVD, all-cause mortality, and cancer risk	Fasting lipids HbA1c Fasting glucose Blood Pressure monitoring Waist circumference	Aggressive approach to risk reduction through combination of lifestyle modifications aimed at weight reduction, plus the use of antihypertensive, lipid-lowering and glucose-lowering agents

## Abnormal Gonadotropin Secretion

Abnormal patterns of gonadotropin secretion have long been recognized as a common characteristic of women with PCOS. As discussed earlier in the section of this chapter devoted to the pathophysiology of the disorder, increased serum LH concentrations, low-normal FSH levels, and increased LH/FSH ratios are typical, but not universal. Altered LH/FSH ratios are more often encountered in the lean than in obese women with PCOS. In the past, an increased LH/FSH ratio (e.g., >2:1) has been regarded as a marker of PCOS, but the dependence of results on assay sensitivities and the now recognized inherent differences in circulating gonadotropin levels by degree of adiposity limit the reliability of LH/FSH ratios for establishing PCOS diagnosis.<sup>8, 67, 320, 321, 322</sup> **Consequently, gonadotropin levels or ratios are not a reliable diagnostic criterion; they neither make, nor exclude, the diagnosis of PCOS.**

## Insulin Resistance

Insulin resistance and hyperinsulinemia are common but not universal features of women with PCOS, no matter what method is used to assess insulin sensitivity.<sup>101, 103</sup> **The overall prevalence of insulin resistance among women with PCOS is between**

**30% and 35% and is greater in the obese than in lean PCOS population.**

Most women with PCOS and insulin resistance are young and have ample pancreatic B-cell reserve. Consequently, they are able to generate a compensatory hyperinsulinemia, allowing them to maintain normal glucose homeostasis, at least in the fasting state.<sup>107</sup> Although most therefore display an exaggerated insulin response to a glucose challenge, some also exhibit evidence of B-cell dysfunction,<sup>323, 324, 325</sup> particularly those having a family history of type 2 diabetes mellitus.<sup>326</sup>

There is no debate that insulin resistance and hyperinsulinemia play an important role in the pathophysiology of PCOS. However, there is no universal testing modality, which can make diagnosis of insulin resistance difficult. Acanthosis nigricans (further discussed under the section on severe insulin resistance syndromes) serves as a clinical hallmark of insulin resistance (**Figure 11.14**).



**FIGURE 11.14**

The gold standard method for measuring insulin sensitivity (a concept that reflects the opposite of insulin resistance) is the **hyperinsulinemic-euglycemic clamp** to which all other methods are compared.<sup>25, 327</sup> The technique involves a fixed-rate intravenous infusion of insulin and a simultaneous intravenous glucose infusion, varying the rate as needed to establish a steady-state plasma glucose level within the normal fasting range. The glucose infusion rate at steady state estimates the rate of glucose uptake in tissues at the defined plasma insulin concentration and is inversely proportional to the degree of insulin resistance; the lower the glucose infusion rate at steady state, the greater the degree of insulin resistance. Insulin sensitivity is defined as the ratio of the glucose disposal rate to the steady-state insulin concentration (glucose disposal rate [mmol/kg]  $\times$  min per mU/L  $\times$  100). The clamp technique and other methods involving intravenous

infusions of glucose and/or insulin (e.g., the frequently sampled intravenous glucose tolerance test, the insulin sensitivity test, the insulin tolerance test, and the continuous infusion of glucose with model assessment) have been used extensively in clinical investigations of glucose and insulin dynamics. However, they have no real practical clinical application because they are time-consuming, invasive, and costly and require experienced personnel.

The complexities of clamp techniques and other methods requiring intravenous infusions and multiple blood samplings spurred efforts to find an uncomplicated and inexpensive quantitative method for evaluating insulin sensitivity. A number of fasting state (homeostatic) measures have been described, all based on the fasting glucose and insulin concentrations and using straightforward calculations.<sup>328</sup> One common weakness that all such methods have is that they assume a linear relationship between glucose and insulin that is, in fact, parabolic.

The **fasting serum insulin concentration** is easy to obtain and requires no calculations<sup>329</sup>; in euglycemic white women with PCOS, values greater than 20–30 mU/mL suggest insulin resistance. The **fasting glucose/insulin ratio** has been used widely as an index of insulin sensitivity across populations including in women with PCOS; a ratio less than 4.5 has reasonable sensitivity and specificity for insulin resistance.<sup>103</sup> The **homeostatic model assessment of insulin resistance (HOMA-IR)** is another measure of insulin sensitivity commonly used in larger epidemiologic studies. The HOMA-IR is calculated by dividing the product of the fasting glucose (mg/dL) and insulin (mU/mL) concentrations by a constant: (glucose [mg/dL]) (insulin [mU/mL])/405 or (glucose [mmol/L]) (insulin [mU/mL])/22.5.<sup>330, 331</sup> The HOMA-IR value correlates relatively well with results from clamp studies<sup>332, 333</sup> and, unlike the fasting insulin concentration and the glucose/insulin ratio, compensates for fasting hyperglycemia; values greater than 3.2–3.9 generally indicate insulin resistance.<sup>38, 334, 335</sup> The **quantitative insulin sensitivity check index (QUICKI)** is yet another method for assessing insulin sensitivity in clinical investigations. Like the HOMA-IR, QUICKI can be applied in both euglycemic and hyperglycemic patients.<sup>336</sup> The QUICKI value is the inverse of the sum of the fasting glucose and insulin concentrations, expressed logarithmically:  $(1/[\log(\text{glucose}) + \log(\text{insulin})])$ ; values greater than 0.33 indicate insulin resistance.<sup>38, 337</sup> Still other methods use a weighted combination of the fasting insulin and triglyceride concentrations and BMI to estimate insulin sensitivity.<sup>327</sup> All of the calculated indices have limitations, primarily the lack of a standardized insulin assay. **As the sheer number of different measures of insulin resistance demonstrates, there is no uniformly accepted test for measuring insulin resistance in a clinical setting. However, a combination of routinely undertaken evaluations (such as estimates of fasting glucose and insulin levels and results of OGTT) and**

**evidence of acanthosis nigricans and central obesity on clinical examination can provide meaningful insights into existence of insulin resistance in a clinical setting.**

The standard **OGTT** is the mainstay of methods for diagnosis of abnormalities of glucose homeostasis such as impaired glucose tolerance and diabetes mellitus and also can be used to assess insulin sensitivity and magnitude of insulin resistance (discussed below). Although the techniques may vary, all involve measures of plasma glucose (and insulin) at intervals over 2–4 hours after a 75- or 100-g oral glucose load. Inclusion of timed insulin estimates during the course of an OGTT allows a meaningful quantification of insulin resistance as it will identify patients who require larger amounts of insulin in order to remain euglycemic as in the absence of insulin response, estimates of glucose levels alone do not allow an insight into the magnitude of transient hyperinsulinemia that follows ingestion of a finite glucose load. **A baseline 2-hour OGTT is recommended for all women with PCOS, as up to 35% exhibit impaired glucose tolerance and up to 10% have diabetes mellitus.**<sup>36, 109, 338, 339, 340</sup> **Screening for glucose intolerance also is recommended for girls with premature adrenarche or menstrual irregularity that persists for more than 2 years after menarche because hyperinsulinemia often is a contributor to dysfunction of the HPO axis and they are at high risk for developing diabetes and severe hyperandrogenism.**<sup>341, 342, 343, 344</sup> In this population, specific screening for insulin resistance also is warranted because evidence indicates that early intervention in those affected can prevent progressive debilitating disease.<sup>343, 345, 346</sup> Specific screening for insulin resistance also is recommended for women with markedly elevated serum androgen levels ( $\geq 150$  ng/dL), to differentiate the severe insulin resistance syndromes (discussed below) from androgen-secreting tumors ([Table 11.5](#)).

## **TABLE 11.5 Interpreting Glucose and Insulin Response During 2-Hour Oral Glucose Tolerance Test (75 grams glucose load)**

Timing	Glucose (mg/dL)	Insulin (mU/mL)	Interpretation
Fasting (0 min)	<100	<20	<b>Impaired fasting glucose (IFG)</b> is between 100 and 125.99 mg/dL <b>Diabetes mellitus</b> if fasting glucose level is $\geq 126$ <b>Insulin-resistant</b> if fasting insulin level is $>20$
30–90 min	<200	<80–100 Level peaks at 30 min and should decline over time and remain <80–100	<b>Insulin-resistant</b> if insulin level is $\geq 80$ –100 at any time <b>Severe insulin resistance</b> if insulin level is $>300$
120 min	<140	Level should be less than at 90-min interval $<80$	<b>Impaired glucose tolerance (IGT)</b> if glucose level is between 140 and 199.9 mg/dL <b>Diabetes mellitus (DM)</b> if glucose level is $\geq 200$ mg/dL <b>Insulin-resistant</b> if insulin level is $>55$ <b>Severe insulin resistance</b> if insulin level is $>100$

## Dyslipidemia

Dyslipidemia is perhaps the most common metabolic abnormality observed in women with PCOS. Applying the National Cholesterol Education Program guidelines, nearly 70% have at least one borderline or elevated lipid level,<sup>347</sup> although many women with PCOS have entirely normal lipid profiles.<sup>348,349,350,351,352,353</sup> Insulin resistance and hyperinsulinemia are associated with decreased high-density lipoprotein (HDL) cholesterol and elevated triglyceride levels, and numerous studies have observed such abnormalities in women with PCOS.<sup>350,354,355</sup> Some also have observed elevated low-density lipoprotein (LDL) concentrations,<sup>158,351,352,353</sup> which are not usually associated with insulin-resistant states and may result from hyperandrogenism or reflect a genetic or dietary influence, and although this can be seen in both lean and obese women with PCOS, this metabolic abnormality is more prevalent in the setting of excess adiposity.<sup>35,349,356,357</sup>

## Inflammation

PCOS is a proinflammatory state.<sup>358</sup> Several studies have demonstrated that glucose can elicit an inflammatory response in mononuclear cells of women with PCOS, regardless of body weight.<sup>359</sup> In addition, hyperandrogenism, a common feature of PCOS, leads to maturation of adipocytes, which favors central obesity.<sup>359</sup> The adipocyte maturation results in adipocyte hypertrophy and ultimate hypoxia from inadequate perfusion. As increased central adiposity is present in PCOS patients regardless of BMI, this may explain the inflammatory state of PCOS.<sup>359</sup> The end result is recruitment of macrophages, which produce inflammatory cytokines, perpetuating a systemic inflammatory response and negatively impacting glucose metabolism.<sup>359</sup> In a systematic

review and meta-analysis studying the status of inflammatory markers in women with PCOS compared to non-PCOS women, it was found that C-reactive protein (CRP) was elevated in PCOS.<sup>358</sup> CRP is a marker of chronic inflammation and is correlated with insulin resistance, body weight, and adipose mass.<sup>359</sup> Treatment with metformin lowers CRP levels.<sup>359</sup>

## **Cancer Risk**

Chronic anovulation, obesity, and hyperinsulinemia provide an environment that is conducive to risk for proliferative endometrial pathologies such as endometrial hyperplasia and even endometrial cancer in women with PCOS.<sup>360,361,362,363,364</sup> The constant, unrelenting estrogen stimulation of the endometrium as well as the growth-promoting effects of insulin predisposes women with PCOS to abnormalities of the endometrium<sup>365</sup>; endometrial hyperplasia and even endometrial cancer can be encountered in young anovulatory women.<sup>366,367,368</sup> The risk for endometrial cancer may be as high as threefold greater in anovulatory women with PCOS compared to women with normal reproductive physiology.<sup>369</sup>

## **Exclusion of Other Disorders**

PCOS is a diagnosis of exclusion, after considering and eliminating other causes of chronic anovulation (primarily thyroid disorders and hyperprolactinemia) and of androgen excess. Together, CAH, androgen-secreting tumors, severe insulin resistance syndromes, Cushing syndrome, and idiopathic hirsutism account for about 10–30% of hyperandrogenism in women.<sup>171,288,293,370</sup> **All should be considered and excluded and are discussed in detail in other chapters, but briefly reviewed here (Table 11.6).**

### **TABLE 11.6 Conditions that Can Masquerade as PCOS**



Condition	Features Shared with PCOS	Unique Features and Methods for Exclusion
Late-onset congenital adrenal hyperplasia (Chapter 13)	Oligoanovulation Hyperandrogenism Hyperandrogenemia	Autosomal recessive disorder Elevated 17-OHP levels in the commonest variant due to 21-hydroxylase deficiency
Androgen secreting tumor Ovarian (Chapter 12) Adrenal (Chapter 13)	Oligoanovulation Hyperandrogenism Hyperandrogenemia	Rapid progression of clinical symptoms of hyperandrogenism Signs of virilization Markedly elevated total testosterone levels Elevated DHEA-S levels
Cushing syndrome (Chapter 13)	Oligoanovulation Hyperandrogenism Hyperandrogenemia	Clinical stigmata including hypertension, moon facies, buffalo hump, skin plethora, hypertension Elevated 24-hour urine-free cortisol (Chapter 13)
Hyperprolactinemia (Chapters 4 and 5)	Oligoanovulation	Elevated prolactin levels
Hypothyroidism (Chapter 20)	Oligoanovulation Coarsening of hair Hair loss	Elevated TSH levels (primary hypothyroidism) Positive antithyroid antibodies (Hashimoto thyroiditis)
Iatrogenic Androgenic agents Antidepressants Antiseizure	Oligoanovulation Hyperandrogenism	Androgen exposure Suppressed FSH/LH levels Elevated total testosterone Antidepressants and antiseizure Hyperprolactinemia
Severe insulin resistance syndrome	Oligoanovulation Hyperandrogenism Hyperandrogenemia	Elevated fasting insulin levels Markedly elevated provoked insulin levels during OGTT Acanthosis nigricans

## Thyroid Disorders

Thyroid disorders are associated with menstrual dysfunction (detail discussion in [Chapter 20](#)). In addition to being causative for ovulatory dysfunction, thyroid disorders can have serious adverse impact on pregnancy outcomes and on child development.<sup>371,372,373,374,375,376</sup> **The overall high prevalence of thyroid dysfunction in women warrants specific testing to exclude the diagnosis in all anovulatory women, including those with evidence of hyperandrogenism. Serum TSH is considered as the gold standard first-line test for assessing primary thyroid disorders.**

## Hyperprolactinemia

Hyperprolactinemia is highly associated with menstrual dysfunction and is one of the most common causes of secondary amenorrhea. The many causes of hyperprolactinemia are considered at length elsewhere in this text ([Chapters 4, 5, and 10](#)). Hyperprolactinemia is associated with increased adrenal androgen production in vivo and in vitro,<sup>377,378</sup> but its prevalence among women who present with hyperandrogenism

is quite low and generally less than 3%.<sup>288,370,379,380,381,382,383,384</sup> **The high prevalence of hyperprolactinemia among women with menstrual dysfunction justifies specific testing to exclude the diagnosis in all women with menstrual abnormalities and ovulatory dysfunction.**

## **Nonclassical Congenital Adrenal Hyperplasia**

CAH is caused by adrenal steroidogenic enzyme defects that result in excessive adrenal androgen production. The most common cause is 21-hydroxylase deficiency; other enzyme defects (11 $\beta$ -hydroxylase, 3 $\beta$ -hydroxysteroid dehydrogenase) are relatively rare. In all, the pathophysiology stems from decreased cortisol production, which stimulates a compensatory increase in pituitary ACTH secretion, causing adrenal hyperplasia; increased levels of steroid hormones proximal to the enzyme block seek an alternative metabolic pathway, resulting in increased production of androgens. The disorder is inherited in an autosomal recessive fashion and is discussed in detail in [Chapter 13](#).

Females with classical CAH (both salt-wasting and simple virilizing forms) typically present at birth with ambiguous genitalia<sup>385,386,387</sup> and thus would rarely be confused with PCOS, but those with the nonclassical or “late-onset” form of CAH present later, during childhood or early adolescence with precocious puberty, or as young adults with signs of hyperandrogenism, very much like those with PCOS.<sup>388</sup> **Whereas it is logical to recommend that nonclassical CAH be excluded specifically in all women with hyperandrogenism,<sup>38</sup> we believe that specific testing can be safely reserved for those having an early onset of hirsutism (pre- or perimenarcheal, including girls with premature adrenarche), women with a family history of the disorder, and those in high-risk ethnic groups (Hispanic, Mediterranean, Slavic, Ashkenazi Jewish, or Yupik Eskimo heritage).** The yield from routine screening is very low, because the disorder is uncommon.<sup>170,171,389</sup> While it is important to identify women at risk for conceiving a child with the more severe classical form of the disorder, the risk among women with hyperandrogenism is limited to those who carry one classic mutation and a variant allele associated with mild enzyme deficiency (compound heterozygotes), also having a male partner who carries an occult classic mutation. In the United States, the prevalence of classical CAH is 1 in 15,500 White and 1 in 42,000 African Americans.<sup>390</sup>

In chronically anovulatory women with evidence of hyperandrogenism, a follicular phase morning serum 17-OHP concentration less than 200 ng/dL excludes, and a level greater than 800 ng/dL all but establishes the diagnosis of late-onset CAH due to 21-hydroxylase deficiency.<sup>391,392,393</sup> Concentrations between the two threshold values

suggest the possibility, which can be confirmed by performing an ACTH stimulation test, obtaining blood samples before and 60 minutes after administering cosyntropin (synthetic ACTH 1–24; 0.25 mg intramuscularly or intravenously); in most women with nonclassical CAH, the 17-OHP concentration will rise above 1,500 ng/dL.<sup>389,394,395</sup>

## Androgen-Secreting Ovarian and Adrenal Tumors

Androgen-secreting ovarian and adrenal tumors are rare. A short history and rapidity in progression of symptoms of androgen excess should alert one of this possibility, and diagnosis can be arrived at through further testing (discussed in [Chapters 12](#) and [13](#)). The prevalence of ovarian androgen-producing tumors is between 1 in 300 and 1 in 1,000 among women with hyperandrogenism.<sup>171,370,381,396</sup> Androgen-secreting adrenal tumors are even less common.<sup>380</sup> Androgen-secreting tumors almost always are accompanied by severe or rapidly progressive hirsutism or symptoms or signs of virilization (deepening of the voice, temporal or male pattern balding, breast atrophy, increased muscle mass, and clitoromegaly). **The possibility of a tumor is excluded primarily by the clinical history and physical examination. A serum total testosterone concentration** greater than 150 ng/dL identifies almost all women with a potential androgen-producing tumor. However, a tumor still should be suspected and excluded in women with rapidly progressive hirsutism or signs or symptoms of virilization, even when the serum testosterone concentration is below the threshold value. Transvaginal ultrasonography will identify almost all solid ovarian mass lesions, although very small tumors located in the hilar region can escape detection. Adrenal computed tomography (CT) is extremely sensitive for detecting rare androgen-secreting adrenal tumors, most of which are malignant. Selective ovarian venous catheterization can be considered for the rare patient having no demonstrable ovarian or adrenal mass lesion, but should be reserved only for those in whom a tumor is strongly suspected.

## Cushing Syndrome

Cushing syndrome results from excess adrenal cortisol secretion and can be ACTH-dependent (pituitary- and ectopic ACTH-secreting tumors) or ACTH-independent (adrenal adenomas, exogenous glucocorticoid treatment). **The disorder has features commonly observed in women with PCOS, including menstrual dysfunction and central obesity. However, the prevalence of Cushing syndrome in women presenting with hyperandrogenism is extremely low, well below 1%.<sup>40,170,171,288,370</sup>** Consequently, routine screening is not justified and should be limited to the very few patients who also have distinct signs and symptoms of hypercortisolism (discussed in detail in [Chapter 13](#)). Symptoms of severe fatigue and muscle weakness and signs suggesting atrophy of the skin and subcutaneous tissue (easy bruising and

purple striae on the abdomen and flanks); hyperpigmentation in areas most exposed to light or chronic mild trauma, friction, or pressure (the elbows, knees, knuckles, and shoulders); hypertension; diabetes; and features of cognitive impairment in an anovulatory woman should raise concerns for Cushing syndrome.

Methods of screening for Cushing syndrome, specific tests for those who screen positive, and evaluation to differentiate among the causes of Cushing syndrome are discussed in detail in [Chapter 13](#). **The overnight dexamethasone suppression test is the best single screening test because of its simplicity and ability to discriminate.** The test is performed by administering 1.0 mg of dexamethasone between 11:00 P.M. and midnight and measuring the serum cortisol at 8:00 A.M. the next morning; values less than 1.8 mg/dL are normal.<sup>385</sup>

## Idiopathic Hirsutism

Idiopathic hirsutism is defined classically as hirsutism (discussed in detail in [Chapter 12](#)) accompanied by normal ovulatory and menstrual function and with normal circulating androgen levels. Using that definition, the prevalence of idiopathic hirsutism among hirsute women is approximately 5–7%.<sup>170,171,293,294,397</sup> If the 2003 Rotterdam criteria for diagnosis of PCOS are used, the definition would also include the absence of PCO, further decreasing the prevalence of idiopathic hirsutism.

By definition, a diagnosis of idiopathic hirsutism requires measurement of serum androgen levels, which otherwise is not necessary for those with mild hirsutism. It is generally assumed that idiopathic hirsutism results from increased peripheral 5 $\alpha$ -reductase activity, which amplifies the action of normal circulating testosterone concentrations via increased intracellular conversion to the more potent androgen, DHT.

## Severe Insulin Resistance Syndromes

Severe insulin resistance is a specific characteristic of a variety of uncommon clinical disorders. The type A insulin resistance syndrome results from defects in the insulin receptor and affects primarily lean women. The type B syndrome is an autoimmune disorder affecting the insulin receptor. The type C syndrome is a variant of type A and is characterized by marked acanthosis nigricans, hyperandrogenism, obesity, and the absence of insulin receptor defects and is also known as the hyperandrogenic insulin-resistant acanthosis nigricans (HAIR-AN) syndrome. Other rare disorders involving severe insulin resistance include leprechaunism, the Rabson-Mendenhall syndrome, and a variety of lipodystrophic syndromes.<sup>38,112</sup>

Although the HAIR-AN syndrome might reasonably be viewed as a severe form or phenotype of PCOS, the more profound insulin resistance and related metabolic

abnormalities in the syndrome distinguish the two.<sup>398,399,400</sup> Ovarian hyperthecosis, characterized by distinct clusters of luteinized theca cells scattered throughout the ovarian stroma and associated with severe hyperandrogenism,<sup>401,402</sup> frequently is observed in women with severe insulin resistance syndromes. Skin tags and acanthosis nigricans (a gray-brown, velvety, sometimes verrucous, discoloration of the skin, usually involving the neck, groin, axillae, and the area beneath the breasts) are other common features of the severe insulin resistance syndromes. The mechanism responsible for their development is uncertain.

Although specific diagnostic criteria for the severe insulin resistance syndromes have not been established, the diagnosis can be substantiated by findings of markedly elevated levels of insulin, typically greater than 80 mU/mL fasting or greater than 300 mU/mL 2 hours after an oral glucose load.<sup>399,400</sup> As might be expected, most patients will have normal glucose levels in the early stages of the disorder, but are at high risk to develop pancreatic  $\beta$ -cell failure and consequent diabetes mellitus, as well as dyslipidemia. Accordingly, such individuals require early institution of primary prevention and secondary intervention strategies aimed at reduction of cardiovascular disease burden as well as require careful long-term follow-up.

## Key Points: Severe Insulin Resistance Syndromes

- Polycystic ovary syndrome is not a specific endocrine disease but is a syndrome represented by a collection of signs and symptoms, and no one sign, symptom, or test is diagnostic.
- Diagnosis of polycystic ovary syndrome is based primarily on the clinical history and physical examination. The major clinical features of polycystic ovary syndrome are chronicity of hyperandrogenism and menstrual dysfunction.
- Although present in most women with chronic hyperandrogenic anovulation, polycystic-appearing ovaries alone do not establish and are not required for diagnosis of polycystic ovary syndrome.
- Gonadotropin levels or ratios are not a reliable criterion for diagnosis of polycystic ovary syndrome.
- Knowing and understanding the health implications and consequences of chronic anovulation and timely initiation of appropriate management strategies are far more important than simply assigning a diagnostic label of PCOS.
- Laboratory evaluation of women with suspected polycystic ovary syndrome should include:
  - **Tests for ruling out common conditions that can mimic PCOS:**
    - Serum thyroid-stimulating hormone (TSH)

- Serum prolactin
- Serum 17-hydroxyprogesterone (especially in women with a pre- or perimenarcheal onset of hirsutism, a family history of congenital adrenal hyperplasia, or high-risk ethnicity time blood draw in morning in follicular phase)
- 24-hour urine-free cortisol if suspecting Cushing syndrome in differential diagnosis
- **Tests that quantify presence, severity, and source of hyperandrogenemia:**
  - Serum total and free testosterone (in women with moderate to severe hirsutism and/or acne or alopecia)
  - Serum DHEA-S (to determine adrenal contribution to signs/symptoms of androgen excess)
- **Tests that allow risk assessment:**
  - Oral glucose tolerance test (2-hour, 75-g glucose load) with frequent sampling for glucose (can consider additionally testing insulin levels)
  - Fasting lipid profile
  - Comprehensive metabolic panel
  - Endometrial sampling to rule out endometrial hyperplasia/cancer (consider in obese women and in those with history of prolonged periods of oligomenorrhea/amenorrhea that indicate long-term endometrial exposure to unopposed estrogen)

# Clinical Management

The management approach for women with PCOS must be individualized to address the symptom burden while harnessing individual's risks and minimizing long-term clinical consequences through tailored management and timely intervention of preventative strategies.

**Women with PCOS may be seeking care for any one or more of the following:**

- Menstrual abnormalities
- Symptom(s) of androgen excess (hirsutism, acne, alopecia)
- Infertility

**Long-term health risks in women with PCOS include:**

- Increased risk for endometrial hyperplasia and neoplasia
- Increased risk for infertility
- Increased risk for type 2 diabetes
- Increased risk for cardiovascular disease

Lifestyle changes are an important part of the clinical management, requiring careful education, counseling, encouragement, and follow-up. For patients having no immediate desire to attempt pregnancy, estrogen-progestin contraceptives provide effective management for menstrual dysfunction and protect against the risk for development of endometrial hyperplasia and cancer. Estrogen-progestin contraceptives and antiandrogens help to prevent or decrease symptoms of hyperandrogenism. In those not interested in taking oral contraceptives, the levonorgestrel-based intrauterine devices serve the dual role of offering excellent endometrial protection and effective contraception. Those seeking to conceive are candidates for ovulation induction, in conjunction with lifestyle modification. Women with impaired glucose intolerance and concomitant risk for developing type 2 diabetes, or having features of the metabolic syndrome, indicating a high risk for developing cardiovascular disease, may warrant consideration for treatment with insulin-sensitizing agents or other medications aimed specifically at reducing those risks. The important point to emphasize is that women with chronic anovulation require comprehensive clinical management that addresses their immediate needs, but also considers their longer-term health and incorporates appropriate risk reduction strategies.

## **Lifestyle Modification: A First-Line Approach**

The strong association between obesity, hyperandrogenism, impaired glucose tolerance,

menstrual abnormalities, and infertility emphasizes the importance of addressing lifestyle issues in women with PCOS, focusing on nutrition and exercise. At least 50% of women with PCOS are obese. **It is important to stress that even a small reduction in weight (2–5%) can result in significant improvements in metabolic and reproductive function.**<sup>22,24,403,404,405,406,407</sup> The loss of abdominal fat may be the best predictor of the effects of weight loss.

**Weight reduction is the first-line management strategy for overweight and obese women.**<sup>408</sup> Weight loss increases SHBG concentrations, thereby reducing free androgen levels and decreasing androgen stimulation of the hair and skin. Weight loss also improves ovulatory function, thereby increasing conception rates and also possibly decreasing the risk for miscarriage. Despite much debate on superiority of low-carbohydrate versus low-fat diets for women with PCOS, **significant overall decrease in net caloric intake remains the most important dietary strategy for weight reduction. While treatment with metformin may facilitate weight loss,**<sup>405,409,410,411</sup> **primarily by suppressing appetite,**<sup>400</sup> **the overall effect is modest and inconsistent.**<sup>412,413,414,415,416,417,418,419,420,421</sup> **Consequently, metformin should not be used primarily for the purpose of weight reduction.** Appropriate designed clinical trials are needed to clearly establish a place of metformin in euglycemic women with PCOS for metabolic benefit.<sup>422</sup>

The benefits of exercise for improving diabetes and cardiovascular health have been demonstrated in the general population. Incorporation of moderate activity into daily activities appears as effective for reducing the risk of developing diabetes and cardiovascular disease as that achieved with vigorous physical activity, is more likely to be sustained, and is essential for maintaining weight loss over time.<sup>423,424</sup>

## **Managing Menstrual Abnormalities and Risk for Developing Endometrial Cancer**

Oligomenorrhea is the most common presentation of women with chronic anovulation, although many present with amenorrhea or abnormal uterine bleeding, and some even have regular menses. The typical patient presents with irregular or infrequent menses or with amenorrhea. While oligomenorrhea is defined as less than eight menstrual cycles per year, risk assessment for endometrial abnormalities and for abnormal bleeding episodes in women with PCOS should take into consideration not just the overall number of menstrual cycles but also the degree of obesity, insulin resistance, and hyperandrogenism, and also the concomitant morbidities. The evaluation and management of amenorrhea are discussed in depth in [Chapter 10](#), and abnormal uterine bleeding is the focus of [Chapter 14](#).



Chronic anovulation, obesity, and hyperinsulinemia all are associated with risk for developing endometrial cancer.<sup>360,361,362,363,364</sup> The mechanism relates to constant, unrelenting estrogen stimulation of the endometrium, predisposing to abnormal patterns of growth. Endometrial hyperplasia and even endometrial cancer can be encountered in young anovulatory women.<sup>366,367,368</sup> Consequently, for those with long-standing anovulation, endometrial sampling to exclude endometrial hyperplasia is a prudent precaution. **The decision on whether to perform an endometrial biopsy should not be based on the patient's age, but on the duration of potential exposure to unopposed estrogen stimulation, and the severity of obesity and insulin resistance must also be given consideration in this regard.** Whereas a grossly increased endometrial thickness (>12 mm) clearly suggests the possibility of endometrial hyperplasia,<sup>425</sup> a normal endometrial thickness does not exclude the diagnosis.<sup>426,427</sup>

Combined oral contraceptives (COCs) are the most commonly utilized treatment approach for the menstrual abnormalities associated with chronic anovulation, although transdermal and vaginal formulations of synthetic estrogen and progestins are relatively recent additions to the available combined hormone strategies (discussed in [Chapter 22](#)). The combined estrogen and progestin formulations (oral and non-oral) provide endometrial protection due to their progestin component, which attenuates the endometrial growth, thereby preventing abnormal uterine bleeding and also attenuating the risk for developing endometrial hyperplasia and neoplasia. Predictable and lighter withdrawal bleeding is seen with cyclic use of combination hormone regimens, thus offering both physical and psychological benefits. In those who are unable to use combination hormonal regimens (this may be due to bothersome side effects or because of factors that contraindicate the use of such regimens, as discussed in [Chapter 22](#)), effective endometrial protection and cycle regulation can be achieved with progestin-alone continuous or cyclic regimens. A number of effective formulations are available for use that offer various routes of administration (oral, subcutaneous, intramuscular, intravaginal, and intrauterine). While offering effective endometrial protection and contraceptive benefits, the progestin regimens however are lacking in some important actions that the combined estrogen-progestin contraceptives offer in the treatment of hyperandrogenism, as discussed in [Chapter 12](#) and briefly reviewed below.

## Hirsutism

Nearly two-thirds of anovulatory women complain of cosmetically disturbing hirsutism. The severity of hair excess in women with PCOS relates to the level of hyperandrogenemia, degree of adiposity, and genetic sensitivity of the individual's hair follicles to androgens. Hirsutism is more common in obese anovulatory women; free androgen levels increase with increasing BMI the combined inhibitory effects of insulin

and androgens on hepatic SHBG production. Skin and hair disorders can be both physically and psychologically very damaging. The spectrum of treatments for hirsutism is discussed in [Chapter 12](#) and briefly summarized here.

Mild focal hirsutism can be managed effectively with cosmetic measures (shaving, plucking, waxing, electrolysis, or laser hair removal), but most who present with a complaint of hirsutism are already using one or more such methods and may require additional treatment. Medical management options include primarily combination estrogen-progestin contraceptives, topical agents, and antiandrogens.

COCs are an effective treatment for hirsutism primarily because they suppress LH-dependent ovarian androgen production and stimulate hepatic SHBG production.<sup>428,429,430,431,432,433</sup> Some have questioned the wisdom and safety of estrogen-progestin contraceptives in women with PCOS, primarily because they have been associated with modest decreases in insulin sensitivity in some studies.<sup>434,435,436,437,438</sup> However, the overall weight of available evidence supports their safety in women with PCOS, with and without insulin resistance.<sup>349,418,439,440,441,442,443,444,445,446,447,448,449</sup>

Antiandrogens are effective for the treatment of hirsutism, but must be used in combination with a highly reliable contraceptive method (e.g., an intrauterine device) because of their potential to adversely affect sexual development in a male fetus if the patient were to conceive unexpectedly. Options commonly utilized in clinical practice include spironolactone (50–100 mg twice daily)<sup>450,451</sup> and finasteride (5 mg daily).<sup>452</sup> Flutamide, while an effective antiandrogen, has a concerning safety profile and caution is advised against its use in PCOS management. It is important to review side effects/risks associated with each—spironolactone can cause orthostatic hypotension and/or hyperkalemia (caution in those with renal disease); finasteride is overall well tolerated, with minimal hepatorenal toxicity.<sup>453</sup>

Eflornithine is a reversible inhibitor of ornithine decarboxylase, an enzyme that is needed for cell division,<sup>454</sup> and eflornithine hydrochloride is available as a topical treatment that, if applied regularly, is effective in slowing the growth of unwanted facial hair; continued use is however required for maintaining effectiveness.

Although a number of strategies including treatments with insulin-sensitizing agents (metformin, thiazolidinediones), statins, vitamin D, and stereoisomers of inositol have demonstrated reduction in circulating androgens, effects of such interventions on hirsutism have ranged from lacking to minimal or inconsistent,<sup>111,455,456,457,458,459,460,461,462,463,464</sup> and guidelines issued by the Endocrine Society, the European Society of Human Reproduction, and the American Society for Reproductive Medicine (ASRM) are unified in suggesting against their use for the treatment of hirsutism.<sup>249,349</sup>

## Alopecia

Loss of scalp hair can cause significant psychosocial burden. Unfortunately, effective and reliable therapies are limited. As discussed in [Chapter 12](#), a trial of antiandrogens can be considered. In women with evidence of hyperandrogenemia, a combination of COCs and spironolactone can be tried, whereas when circulating androgen levels are normal, finasteride may be preferred given its effects at lowering tissue DHT levels. Notably, any reliable long-term data on the magnitude of benefit, if any, from use of antiandrogens in managing PCOS-related alopecia are lacking. Topical minoxidil in concentrations recommended for men (5%) has been shown to offer some benefit with minimal side effects and should be offered to women who are particularly bothered by hair loss/thinning. Hair transplant may be an expensive but effective option to consider.

## Infertility

Chronic anovulation is one of the most common causes of infertility. Infertility however is a couple's problem, and despite the female partner's diagnosis of PCOS, evaluation must rule out factors in addition to ovulatory disturbance as a cause for couple's infertility. Factors other than lack of ovulation may contribute to reproductive compromise in women with PCOS, such as factors relating to oocyte quality or endometrial receptivity, and metabolic abnormalities may also contribute.<sup>349,458</sup> When anovulation is determined as the mechanism for infertility, strategies to achieve ovulation should be considered as first-line approach. Methods for ovulation induction are the subject of [Chapter 27](#) and are outlined briefly here.

Until fairly recently, the first ovulation-inducing drug of choice for women with PCOS was clomiphene citrate. However, the Pregnancy in Polycystic Ovary Syndrome II (PPCOS II) randomized controlled trial established superiority of letrozole (an aromatase inhibitor) over clomiphene in achieving significantly higher live birth and ovulation rates among infertile women with PCOS.<sup>459,460</sup> PPCOS II was a double-blind, multicenter trial, where anovulatory women diagnosed with PCOS by Rotterdam criteria and seeking fertility were randomized to receive letrozole or clomiphene for up to five treatment cycles. The rationale for this trial was based on previous findings that demonstrated an overall success rate (defined as live birth rate) with clomiphene of only 22% (following six treatment cycles).<sup>460</sup> The incidence of clomiphene resistance (i.e., failure to ovulate) was as high as 25%, underscoring a need to explore alternative treatment options to achieve successful ovulation in women with PCOS. In PPCOS II trial, women with PCOS were randomized to treatment with starting doses of 50 mg of clomiphene or 2.5 mg of letrozole, with increased doses as needed for each group (not to exceed the maximum dose of 150 or 7.5 mg, respectively).<sup>459,460</sup> Significantly higher cumulative live birth rate of 27.5% was observed in subjects randomized to receive

letrozole compared to 19.1% in women receiving clomiphene in a rate ratio of 1.44 (95% CI 1.10–1.87).<sup>460</sup> Monthly ovulation rates as well as likelihood for singleton pregnancy were significantly higher in those treated with letrozole compared to clomiphene, whereas rates of pregnancy loss were similar between the two groups. It is important to note that the mechanisms of action for letrozole and clomiphene are distinct. Clomiphene, as a selective estrogen receptor modulator (SERM), competitively binds the estrogen receptors at the level of the hypothalamus, thereby releasing the higher centers from the negative feedback effects of estrogen, allowing an increased pituitary secretion of FSH, which then acts at the dormant ovarian follicles to initiate follicular growth. In contrast to the SERM-like effects of clomiphene, aromatase inhibitors (represented by letrozole in PPCOS II), by blocking the enzyme aromatase (which is responsible for conversion of androgens to estrogens, as discussed in [Chapters 12 and 13](#)), bring about a profound decrease in both the circulating and tissue levels of estrogens, with consequent withdrawal of the negative feedback effects of estrogen at the hypothalamo-pituitary axis, and rise in endogenous FSH secretion by the pituitary. Unlike clomiphene that has a long half-life (in weeks), the half-life of letrozole is fairly short (48 hours). Despite its availability and increasing utilization as first-line approach to managing ovulatory dysfunction of PCOS, the choice of aromatase inhibitors for ovulation induction represents an off-label use as this class of drugs has not gained approval of regulatory bodies such as the FDA (in the United States). The rates of maternal and neonatal complication and fetal anomalies in pregnancies resulting from exposure to clomiphene and letrozole were comparable and offer reassurance regarding safety of letrozole as an ovulation induction agent. **It is our opinion that based on existing evidence, letrozole should be considered as a first-line agent for ovulation induction in women with PCOS and in those with a history of resistance to clomiphene. For women with PCOS who fail to achieve successful pregnancy despite multiple successful ovulations with the use of either clomiphene or letrozole, consideration should be given to proceeding directly to in vitro fertilization with single embryo transfer as a strategy that maximizes likelihood of achieving pregnancy while minimizing risks of ovarian hyperstimulation syndrome (OHSS) and multiple pregnancy that women with PCOS are particularly susceptible to with the use of gonadotropins to achieve ovulation induction.**

Treatment with insulin-sensitizing agents (metformin, thiazolidinediones, D-chiro-inositol, and myoinositol) has been used in attempts to increase/improve ovulation rates.<sup>461</sup> Metformin has been widely used for this purpose, yet studies have not demonstrated superiority to other agents/ovulation induction regimens.<sup>349,462,463,464,465</sup> PPCOS I was the largest clinical trial that compared the efficacy of metformin alone with that of clomiphene alone, and with combination of metformin and clomiphene, in women with PCOS. This randomized controlled trial confirmed superiority of

clomiphene as an ovulation induction agent over metformin; clomiphene treatment yielded a significantly higher live birth rate compared to metformin alone (22.5% vs. 7.2%), and while higher live birth rates were seen in the combined treatment group (26.8%), this difference was not of statistical significance.<sup>464</sup> A 2008 meta-analysis including 17 randomized trials concluded that combined treatment with metformin and clomiphene achieves higher ovulation and pregnancy rates than treatment with clomiphene alone, but there was no improvement in live birth rate.<sup>462,466</sup> In a few small studies involving clomiphene-resistant anovulatory women with PCOS, combined treatment has increased ovulation and pregnancy rates over those achieved with clomiphene alone, yet these studies did not assess live birth rate.<sup>467,468,469,470</sup> Information on whether addition of metformin to letrozole regimens may offer any benefit is currently lacking. At this time, routine use of metformin is not recommended for improving fertility or live birth rates.<sup>349</sup> Limited evidence indicates that combined treatment with metformin and rosiglitazone,<sup>471</sup> or with clomiphene and rosiglitazone,<sup>472</sup> is no more effective than metformin alone. In a recent Cochrane review, given the lack of primary outcomes reported in available studies, no definitive conclusions can be drawn regarding clinical pregnancy rates or live birth rates when using rosiglitazone.<sup>461</sup>

There is no evidence that metformin treatment during pregnancy is associated with any increased risk for major fetal malformations.<sup>473</sup> Metformin use in pregnancy has been examined as a strategy to reduce risk of development of gestational diabetes as well as to mitigate risk of miscarriage, with inconsistent results. The risk for miscarriage may be higher in women with PCOS compared to those without PCOS, and underlying metabolic disturbances are suggested to play a role.<sup>161,474,475,476</sup> Miscarriage risk reduction has been demonstrated, although inconsistently, with the use of metformin in women with PCOS.<sup>463,464,465</sup> Others have shown that stopping metformin at the time of pregnancy diagnosis does not affect miscarriage risk.<sup>349</sup> Metformin treatment during pregnancy also has been advocated to reduce the risk for developing gestational diabetes and other pregnancy complications in women with PCOS.<sup>477</sup> Given its favorable effects on several metabolic parameters, potential for facilitating ovulatory response to clomiphene (such as in those who have demonstrated resistance to trial of ovulation induction), lack of adverse fetal effects, and even a potential for mitigating incidence of gestational diabetes, for women who are already on metformin regimen, it may be reasonable to consider continuing through the first trimester of pregnancy. However, currently metformin treatment during pregnancy is not routinely recommended for women with PCOS.<sup>478</sup>

Induction of ovulation with exogenous gonadotropins is highly effective, but requires careful monitoring to avoid the intrinsic risks of multiple pregnancy and OHSS. Many women are highly sensitive to low doses of medication and exhibit a relatively

narrow therapeutic range.<sup>479,480,481,482,483,484</sup> Interestingly, metformin use has emerged as a risk reduction strategy against OHSS in women with PCOS as evidence indicates the risk for OHSS is decreased with concomitant use of metformin.<sup>485,486,487</sup>

Two different stereoisomers of inositol (D-chiro-inositol and myoinositol) have been systematically examined for their effects on endocrine and metabolic profiles and in facilitating ovulatory response in women with PCOS. Inositol and its isomers are involved in glucose metabolism, specifically the transport of glucose and its conversion to glycogen.<sup>488</sup> Utilization of myoinositol specifically in PCOS patients has demonstrated improvement in both ovarian function and metabolism (i.e., reduced insulin resistance).<sup>488</sup> Although the bulk of data are mixed with some studies showing improvements in insulin sensitivity, lowering of androgens, and improved ovulatory responses, with others demonstrating null effects, a combination of the two stereoisomers in the ratio of 1 (D-chiro-inositol) to 40 (myoinositol) has shown promise with evidence of clinical, endocrine, and metabolic improvements.<sup>126,127,128</sup>

Laparoscopic ovarian drilling (LOD), with laser or diathermy (monopolar or bipolar), is effective in restoring ovulatory function in women with PCOS, albeit in the short term.<sup>489,490,491</sup> When deliberating on the choice of LOD as a strategy to improve chances of spontaneous ovulation, the choice of instrument (laser or electrocautery), number and depth of punctures, and laterality (bilateral or unilateral ovarian drilling) must be given due consideration. Given the risks of surgery including potential for pelvic adhesive disease and detriment to ovarian reserve, as well as availability of a widening range of medical strategies, surgical management is often relegated to near bottom of strategies currently available for the management of PCOS.<sup>492</sup>

Vitamin D deficiency (serum 25-hydroxy level <30 ng/mL, as per the Endocrine Society guidelines) has been associated with a reduced likelihood for live birth in populations undergoing various infertility treatments.<sup>493</sup> In a secondary analysis of PPCOS I clinical trial, serum 25-hydroxy D levels (a circulating metabolite that reflects the status of vitamin D) were tested in stored sera from 540 women with PCOS, and the relationship between vitamin D status and likelihood for ovulatory response and live birth following ovulation induction was examined.<sup>494</sup> Women with evidence of vitamin D deficiency were significantly less likely to achieve ovulation and live birth following ovulation induction with clomiphene (with and without metformin). Interestingly, the likelihood of treatment-related live birth was fourfold higher in those with serum 25-hydroxy D level in excess of 45 ng/mL. The existing data relating vitamin D deficiency with fertility are almost entirely observational, and intervention trials are needed to examine and establish if a cause and effect relationship exists to the observed associations. However, while awaiting confirmation of this impression, normalization of vitamin D status through judicious supplementation represents a simple, cost-

effective, and safe approach toward optimizing fertility treatment–related successes.

## **Metabolic Abnormalities and Associated Health Risks**

Women with PCOS commonly exhibit insulin resistance and other risk factors for the development of type 2 diabetes and cardiovascular disease. These observations have focused a great deal of attention on the importance of incorporating risk reduction strategies into the clinical management of women with PCOS.

Insulin resistance results in compensatory hyperinsulinemia, which predisposes to a progressive decline in pancreatic  $\beta$ -cell reserve, leading to glucose intolerance and ultimately type 2 diabetes mellitus. In women with PCOS, pancreatic  $\beta$ -cell dysfunction can be demonstrated even before glucose intolerance becomes apparent, and the rate of progression from glucose intolerance to frank diabetes is increased<sup>109,495,496</sup>; up to 10% of women with PCOS develop type 2 diabetes before the age of 40.<sup>107,109,497</sup> Obesity adds to the risk, by aggravating the underlying insulin resistance. Overall, the risk for developing impaired glucose tolerance or type 2 diabetes is increased four- to sevenfold in women with PCOS, compared to women of comparable age without PCOS.<sup>107,109,496,498</sup>

Although direct evidence for an increased incidence of cardiovascular disease in women with PCOS is lacking, the prevalence of known risk factors and surrogates of cardiovascular disease (such as hypertension, endothelial dysfunction, and increased carotid intimal-medial thickness) is substantially increased.<sup>499,500,501</sup> Insulin resistance and hyperinsulinemia are associated with chronic low-grade inflammation, as reflected by elevations in CRP, interleukin-6, leukocyte count, and other inflammatory markers.<sup>502,503,504,505,506,507</sup> Hyperinsulinemia also is associated with hypertension and increased production of plasminogen activator inhibitor-1 (PAI-1), thereby inhibiting fibrinolysis.<sup>508,509</sup> Hyperandrogenemia and obesity each contribute to dyslipidemia and aggravate the underlying insulin resistance in PCOS. Consequently, many women with PCOS have some degree of dyslipidemia, such as decreased HDL cholesterol and increased total and LDL cholesterol, and elevated triglycerides.<sup>354,510</sup> Many also have central obesity, and some even meet the criteria for the diagnosis of the metabolic syndrome, a condition that is predictive of a higher risk for developing cardiovascular disease.<sup>511,512,513</sup> Despite manifesting a plethora of cardiovascular risks, the incidence of cardiovascular events is not as high as estimates project as not all patients with PCOS experience adverse cardiovascular events, making a direct relationship between the two difficult.<sup>25</sup>

The **metabolic syndrome**, originally known as syndrome X,<sup>514</sup> represents a constellation of closely related cardiovascular risk factors, and several studies have

observed an increased prevalence of metabolic syndrome in women with PCOS.<sup>511,515</sup> A number of different definitions for the metabolic syndrome have been proposed, varying in emphasis on abnormalities in glucose metabolism (insulin resistance, hyperinsulinemia, glucose intolerance, diabetes mellitus), central obesity, and cardiovascular risk factors (hypertension, increased triglycerides, decreased HDL cholesterol).<sup>516,517,518,519</sup> Although all of the definitions yield comparable estimates of the overall prevalence of the metabolic syndrome, they identify different populations in different ethnic groups.<sup>520</sup> For example, the risk for type 2 diabetes increases at much lower levels of body fat in Asians than in Europeans (White people of European origin).<sup>521</sup> The definition proposed by the International Diabetes Federation (IDF) in 2005 attempted to reconcile the differences in definitions and to produce a consensus definition that would be useful for identifying those at risk for developing cardiovascular disease in all populations and also allowing comparative long-term studies.<sup>522</sup> The IDF definition views central obesity (as defined by waist circumference) as an essential component of the metabolic syndrome, because of the strength of the evidence linking waist circumference with cardiovascular disease and the other components of the syndrome and the strong likelihood that central obesity is an early step in the pathophysiologic cascade leading to full expression of the metabolic syndrome.<sup>519</sup> **As defined by the National Heart, Lung, and Blood Institute and the American Heart Association, a diagnosis of metabolic syndrome requires the presence of any three of the following five clinical characteristics<sup>522</sup>:**

- **Increased waist circumference (population specific, >88 cm in women in the United States)**
- **Increased blood pressure ( $\geq 130$  mm Hg systolic;  $\geq 85$  mm Hg diastolic) or receiving medication for hypertension**
- **Increased triglycerides ( $\geq 150$  mg/dL) or receiving medication for hypertriglyceridemia**
- **Decreased HDL cholesterol ( $< 50$  mg/dL) or receiving medication for reduced HDL**
- **Increased fasting glucose ( $\geq 100$  mg/dL) or receiving medication for hyperglycemia**

Our recognition of a central role of insulin resistance in the pathophysiology of PCOS and our knowledge of its potential longer-term health consequences have focused a great deal of attention on the benefits of insulin-sensitizing medications and other drugs aimed at reducing the risks for developing diabetes and cardiovascular disease.

Metformin is a biguanide oral insulin-sensitizing agent and currently is the most



widely used drug in the world for the treatment of type 2 diabetes mellitus. Metformin decreases hepatic glucose production, decreases intestinal glucose uptake, and increases peripheral insulin sensitivity; metformin also inhibits lipolysis, resulting in decreased circulating concentrations of free fatty acids, which further helps to reduce hepatic gluconeogenesis.<sup>478,523,524</sup> Mechanism of action of metformin is not entirely clear, but involves activation of the adenosine monophosphate–activated protein kinase pathway in the liver and skeletal muscle.<sup>525,526,527,528,529</sup>

A large number of trials have observed beneficial effects of metformin in women with PCOS; in most, the dose has ranged between 1,500 and 2,000 mg daily. **In general, metformin treatment increases insulin sensitivity,**<sup>413,421,471,530,531,532,533</sup> **decreases weight and BMI,**<sup>413,416,417,421,534</sup> **decreases blood pressure and LDL cholesterol,**<sup>535</sup> **and overall improves the chronic inflammatory state in women with PCOS.**<sup>536</sup> A meta-analysis of 31 trials concluded that metformin increases insulin sensitivity up to 20%, decreases weight and BMI by 3–5%, decreases fasting glucose by about 5%, and increases HDL cholesterol and decreases triglycerides by approximately 10% in patients at increased risk for developing diabetes.<sup>537</sup> Insulin resistance improves during metformin treatment, no matter how severe, and in lean and overweight women with PCOS as well as in those who are obese.<sup>421,530,531,533</sup> Weight loss enhances the effects of metformin.<sup>421</sup> Metformin appears to decrease levels of CRP and soluble vascular cellular adhesion molecules (sVCAM), which reflect the low level of chronic inflammation associated with insulin resistance.<sup>503,538,539</sup> Indirect evidence suggests metformin also may improve vascular endothelial function and coronary flow rate in women with PCOS.<sup>540,541,542,543</sup>

Metformin is available in both a regular and a sustained release form that may be associated with fewer gastrointestinal side effects (nausea, vomiting, diarrhea, constipation, bloating, flatulence, heartburn, indigestion, unpleasant metallic taste). To improve tolerance and decrease side effects, it is generally recommended that metformin treatment begin with a low dose (250–500 mg daily), with the dose increasing gradually over an interval of 4–6 weeks until the desired dose is attained. The drug also can interfere with intestinal absorption of vitamin B12, so patients should be alerted to symptoms of vitamin B12 deficiency, which include numbness, paresthesia, macroglossia, memory loss, behavioral changes, and pernicious anemia. Lactic acidosis is a rare complication of metformin treatment, but for that reason, the drug should not be administered to those with renal insufficiency, liver disease, or alcohol abuse.<sup>544</sup> In clinical practice, it may be prudent to establish normal renal function based on serum creatinine level, prior to initiation of therapy.

Thiazolidinediones are another type of insulin-sensitizing agent that has been used

to improve insulin resistance in women with PCOS. They include rosiglitazone, pioglitazone, and, formerly, troglitazone (withdrawn from the market due to concerns about liver toxicity). Thiazolidinediones are synthetic agonists for the peroxisome proliferator-activated receptor gamma (PPAR $\gamma$ ), which serves as a nuclear transcription factor in the regulation of genes involved in carbohydrate, lipid, and protein metabolism (free fatty acids and eicosanoids are the natural receptor ligands). In trials involving women with PCOS, treatment with troglitazone improved insulin sensitivity and glucose tolerance in a dose-dependent manner.<sup>545,546,547</sup> Similar observations have emerged from studies examining the effects of rosiglitazone and pioglitazone in women with PCOS.<sup>471,472,548,549,550,551</sup> However, overall experience with thiazolidinediones is quite limited and they have been associated with cardiac complications, and this class of medications is not recommended for use in reproductive-age women and especially those attempting to conceive.<sup>350,461,552,553</sup>

**Metformin improves insulin sensitivity as much or more than thiazolidinediones and currently remains the preferred insulin-sensitizing agent for women with PCOS.**

Incretins are the newest class of metabolic modulators that based on their mechanisms of action can be considered superior to metformin, at least in theory, although existing data on their use in women with PCOS are thus far limited.<sup>554</sup> Through a combination of effects that include delaying of gastric emptying, inhibition of pancreatic secretion of glucagon, increased insulin secretion, and improved insulin signaling and appetite suppression possibly through central effects, these agents achieve reduction in blood glucose levels while salvaging pancreatic  $\beta$ -cell function. There are two broad classes of incretins that are increasingly being utilized primarily in the management of type 2 diabetes. The first class of incretins is of glucagon-like peptide-1 (GLP-1) receptor analogs that mimic effects of GLP-1, a gut peptide that is secreted by the L cells residing in specified areas of the small intestine (distal jejunum and ileum) in response to dietary carbohydrate and lipid content. This class of incretins is susceptible to degradation by the gastric acid, requiring parenteral administration, and has demonstrated efficacy in improving not just glucose levels but also dyslipidemia as well as facilitating weight loss in diabetics. In a meta-analysis of 7 randomized controlled trials involving 172 women with PCOS, 3-month treatment with a synthetic GLP-1 receptor agonist liraglutide resulted in a significant reduction in BMI (a decrease of 1.65 [0.72–2.58] kg/m<sup>2</sup>,  $p < 0.01$ ).<sup>555</sup> Total testosterone levels were reported in five of the seven studies included in this meta-analysis, and significant reduction in serum testosterone levels (by 0.29 nmol/L,  $p < 0.01$ ) was similarly observed, and nonsignificant improvements in some indices of insulin sensitivity were also noted. The second class of incretins is that of DPP-4 (dipeptidyl peptidase-4) inhibitors.<sup>556</sup> The enzyme DPP-4 is a serine protease transmembrane glycoprotein that is expressed in the cell membrane of many cell types and mediates rapid inactivation of

GLP-1. This class of incretins is orally active, and formulations of a combination of DPP-4 with metformin have demonstrated additive metabolic benefit compared to either used as a single agent. As with the GLP-1 receptor agonists, data in PCOS population are limited, and future studies are needed to better appreciate the magnitude of metabolic benefit these agents can offer to women with PCOS.

Although the benefits of estrogen-progestin contraceptives in the treatment of women with PCOS are undisputed, they generally do not correct any of the metabolic abnormalities commonly observed in women with PCOS.<sup>418,557,558,559,560,561</sup> Although preparations containing drospirenone may have some limited impact,<sup>451</sup> other evidence suggests that even estrogen-progestin contraceptives containing antiandrogenic progestins may even aggravate an underlying chronic inflammatory state.<sup>503,505,560</sup> Not surprisingly, combination therapies aimed at more comprehensive treatment are now emerging, including estrogen-progestin contraceptives and metformin and low doses of metformin (850 mg daily) and an antiandrogen (flutamide, 62.5 mg daily), with or without an estrogen-progestin contraceptive.<sup>456</sup> In women receiving an estrogen-progestin contraceptive, the addition of metformin improves insulin resistance and further reduces hyperandrogenism.<sup>420,441,562</sup> The combination of low doses of metformin (850 mg daily) and an antiandrogen (flutamide, 62.5 mg daily) improves body composition (loss of fat and gain of lean mass) and lipid levels and increases levels of adiponectin, an anti-inflammatory protein secreted from adipose that modulates glucose regulation and fatty acid metabolism.<sup>559</sup> Combined treatment with an estrogen-progestin contraceptive and an antiandrogen has similar effects that are further enhanced if metformin also is added to the treatment regimen.<sup>346</sup> **Overall, these observations demonstrate that the spectrum of metabolic abnormalities that accompanies PCOS can be improved by treatment with low doses of metformin and antiandrogen in adolescents and by their addition to estrogen-progestin contraceptives in young women.**<sup>451</sup> At least in theory, alternative or adjunctive treatment with metformin and antiandrogens is attractive because it may improve or reverse “upstream” abnormalities and help to prevent their “downstream” consequences. **Experience with these combination treatment regimens is still limited, but is growing steadily, suggesting they may soon find their way into clinical practice.**

Dyslipidemia is common in women with PCOS, with many having decreased HDL cholesterol or increased total and LDL cholesterol or triglycerides.<sup>510</sup> As such, interest has turned to the potential benefits of treatment with statins. In the first clinical trial involving women with PCOS, lipid profiles improved more in women randomized to treatment with an oral estrogen-progestin contraceptive and simvastatin (20 mg daily) than in those receiving only the contraceptive.<sup>563</sup> In those receiving simvastatin, markers of systemic inflammation and endothelial function also improved, and serum

testosterone levels decreased to a significantly greater extent.<sup>563,564</sup> In a placebo-controlled trial, treatment with atorvastatin resulted in a significant decrease in serum testosterone, CRP, and insulin resistance and improved lipid profiles.<sup>565</sup> In a trial comparing the effects of simvastatin and metformin, the two drugs decreased testosterone and improved markers of systemic inflammation and endothelial function to a similar extent, but lipid profiles and insulin sensitivity improved only in those receiving simvastatin; results of combined treatment were not different from those of treatment with simvastatin alone.<sup>566</sup>

Statins exert their effects primarily by inhibiting 3-hydroxy-3-methylglutaryl-coenzyme A (HMG-CoA) reductase, the rate-limiting step in the mevalonate pathway leading to cholesterol synthesis.<sup>567</sup> The effects of statins on testosterone concentrations may relate to decreased availability of products of the mevalonate pathway (including cholesterol), to inhibition of the MAPK pathway that mediates the proliferative actions of insulin, or to other mechanisms regulating ovarian steroidogenesis.<sup>566,568</sup> **Statins may offer a promising new approach to the treatment of women with PCOS at risk for developing diabetes and cardiovascular disease. However, it is important to emphasize that statins may be teratogenic and are contraindicated in pregnancy.**<sup>569</sup>

A number of observational studies have examined relationship between serum 25-hydroxy D (a circulating metabolite that is recognized to reflect bodily stores of vitamin D) levels with metabolic parameters including lipid profile, serum levels of inflammatory markers, and indices of insulin sensitivity across populations.<sup>570</sup> In women with PCOS, vitamin D deficiency (serum 25-hydroxy level <30 ng/mL, as per the Endocrine Society guidelines) has been associated with insulin resistance, lipid abnormalities, and biomarkers of oxidative stress and inflammation. Improvements in insulin sensitivity and lipid profile and decrease in inflammatory markers such as TNF- $\alpha$  and CRP as well as reduction in circulating androgen levels hyperandrogenism have been described following vitamin D supplementation in women with PCOS.<sup>38,571</sup>

**Nonalcoholic hepatic steatosis or nonalcoholic fatty liver disease (NAFLD)** constitutes pathologic liver conditions that range from steatosis to nonalcoholic steatohepatitis (NASH). Steatosis is the result of lipid accumulation in parenchyma of the liver, while NASH includes chronic inflammation and fibrosis.<sup>572</sup> The prevalence is 70% of individuals with T2DM, 90% in those who are morbidly obese, and 27–60% of women with PCOS. Insulin resistance appears to be the primary driver, as even in the absence of obesity, women with insulin resistance have an independent risk of developing NAFLD.<sup>572</sup> Androgens also independently predict NAFLD, with a meta-analysis noting an OR of 2.54 (95% CI 2.19–2.95) in women with PCOS and hyperandrogenism, compared to those without hyperandrogenism.<sup>572</sup> Small studies have

demonstrated an improvement in NAFLD with diet and exercise, as well as with metformin.<sup>573</sup>

**Sleep disturbances** are prevalent in PCOS. The exact prevalence of **obstructive sleep apnea (OSA)** in women with PCOS is not known; this is apparent by the wide range in the estimated prevalence—0–69%.<sup>574</sup> What is more apparent, however, is the association of obesity with OSA risk. Obesity contributes to OSA through several mechanisms—increased parapharyngeal fat deposition, altered neural compensatory mechanism for maintaining airway, decreased residual capacity, reduced lung volume from abdominal fat, and increased chest wall thickness.<sup>574</sup> As obesity is also linked to PCOS, the above mechanisms likely apply to women with PCOS. Androgens and altered progesterone levels contribute to OSA in women with PCOS. Hyperandrogenism and low progesterone levels promote OSA by increasing upper airway collapsibility, with or without concomitant impaired sensitivity to ventilator chemoreceptors.<sup>574</sup> Furthermore, in a study of healthy premenopausal women receiving a transdermal testosterone patch (5 mg/day), testosterone increased the apneic threshold in women, which led to breathing instability during sleep.<sup>574,575</sup> OSA itself may also affect the hypothalamic-pituitary axis, as decreased sleep (i.e., as is seen in individuals with OSA) can lead to menstrual abnormalities by affecting GnRH, FSH, and LH pulsatility.<sup>574</sup> Similarly, OSA is associated with insulin resistance, and implementation of continuous positive airway pressure (CPAP) therapy reduces the homeostasis model assessment of insulin resistance. It is postulated that OSA may contribute to the severity of the PCOS phenotype through insulin resistance.<sup>576</sup> As OSA is considered a cardiovascular disease risk factor for women with PCOS, the Endocrine Society recommends screening overweight/obese women (including adolescents) with PCOS for OSA symptoms, with referral to the appropriate provider for definitive diagnosis and treatment.<sup>338</sup>

## Indications for Treatment with Metformin

The best overall approach to the treatment of chronic anovulation and PCOS currently is somewhat controversial. For decades, estrogen-progestin contraceptives have been the standard therapy for women who are not immediately interested in seeking pregnancy, for good reasons. However, the central role of insulin resistance in PCOS and limited evidence suggesting that estrogen-progestin contraceptives may aggravate insulin resistance have raised concerns that such treatment might increase long-term risks for diabetes and heart disease in women already predisposed.<sup>558</sup>

There is no question that the majority of both lean and obese women with PCOS are insulin-resistant<sup>577,578,579,580</sup> and that the prevalence of impaired glucose tolerance and

diabetes is increased in women with PCOS.<sup>107,109,495</sup> In the lean patient, insulin resistance is intrinsic, but poorly understood,<sup>105,138,581</sup> and the obese patient carries an additional metabolic burden.<sup>582</sup> There also is no debate that insulin resistance and PCOS are associated with increased risk for developing hypertension and<sup>168,583,584</sup> dyslipidemia<sup>351,585,586,587</sup> and with a number of other surrogate markers and risk factors for heart disease.<sup>347,502,514,518,546,588,589,590</sup> Understandably, some view PCOS as an early sign, or even as a component, of the metabolic syndrome in women.<sup>558</sup>

Some studies have observed that estrogen-progestin contraceptives decrease insulin sensitivity.<sup>415,437,439,441,591</sup> Overall, the evidence suggests that the effects of estrogen-progestin contraceptives on insulin resistance and glucose tolerance vary with the dose of ethinyl estradiol, with the dose and type of progestin, and with phenotype and, in general, are not clinically important.<sup>418,419,592</sup> No large studies have examined the risk for developing type 2 diabetes in women with PCOS specifically. Studies in healthy women have observed a modest increase in the relative risk for past and current users of estrogen-progestin contraceptives, compared with never users, although the differences were not significant.<sup>593,594</sup> **Estrogen-progestin contraceptives may decrease insulin sensitivity or glucose tolerance, to some extent, in some women, but concerns that the risk may be substantially higher in women with PCOS and underlying insulin resistance are unsubstantiated.**

Similarly, no large studies have examined the effect of estrogen-progestin contraceptives on the risk for developing cardiovascular disease in women with PCOS specifically. Alterations in vascular and endothelial function have been described, and increased death rates from cardiovascular disease have been observed in women with history of menstrual irregularity.<sup>584</sup> Case-control studies have observed that estrogen-progestin contraceptives are associated with an increased risk for myocardial infarction, but events are rare and risk is almost entirely limited to women with hypertension and those who smoke.<sup>595,596,597,598</sup> **Concerns that use of estrogen-progestin contraceptives might pose greater risk for women with PCOS are understandable, but there is no convincing evidence that they do.**

Treatment with metformin might indeed decrease the risk for developing diabetes and heart disease in women with PCOS, but evidence for those benefits is indirect, inferred primarily from studies in patients with impaired glucose tolerance<sup>408</sup> and from studies examining surrogate markers and risk factors for heart disease; conclusive evidence is lacking. The two most common and classical features of PCOS are anovulation and hyperandrogenism, and treatment with estrogen-progestin contraceptives and antiandrogens, or with clomiphene metformin, has little impact on either. Metformin improves menstrual cyclicality and ovulatory function in some women

with PCOS, but not in most, and standard treatments for anovulatory infertility are clearly more effective. Consequently, for the large majority of women with PCOS, metformin treatment alone will not suffice in allowing resumption of spontaneous ovulation, and use of an ovulation induction agent such as an aromatase inhibitor or clomiphene will be required. **The most clinically relevant question is who can benefit most from metformin treatment.**

The most logical candidates for treatment with metformin (aimed at preventing or slowing progression to type 2 diabetes and at reducing longer-term risks for cardiovascular disease) are women with indices of dysglycemia including impaired fasting glucose, impaired glucose tolerance, abnormally elevated hemoglobin A1c levels, or diabetes, those with obvious evidence of severe insulin resistance (acanthosis nigricans),<sup>590,599</sup> and women having other features of the metabolic syndrome, such as central obesity, hypertension, and dyslipidemia. **All women with PCOS should be screened with an OGTT at the time of presentation and at least every 2 years thereafter (or sooner if the clinical picture worsens); those with impaired glucose tolerance warrant annual screening.**<sup>340</sup> **Evaluation must include assessment of blood pressure and should include measuring waist circumference and assessing lipid profile, to help quantify their metabolic risk by identifying those with features of the metabolic syndrome.**

There is good evidence from the Diabetes Prevention Trial that metformin treatment can decrease the risk for progression to diabetes in those with impaired glucose intolerance, by approximately 30% (although better results were observed in those receiving intensive lifestyle interventions).<sup>408</sup> In a retrospective study of 50 women with PCOS treated with metformin (including 11 with impaired glucose tolerance at baseline), impaired glucose tolerance persisted in 5/11 (45%), and reverted to normal in the remainder (6/11, 55%), over an average of 43 months of follow-up.<sup>600</sup>

Overall, available data from small studies demonstrate that there is little if any exacerbation in cardiovascular disease parameters in women with PCOS using COCs.<sup>349</sup> Long-term data are needed to determine if long-term use of hormonal contraceptives may differentially impact on indices of insulin sensitivity, on pancreatic  $\beta$ -cell reserves, and on mechanisms predisposing to cardiovascular disease in women with PCOS compared to women without PCOS. Given the previously mentioned beneficial metabolic effects of metformin, usefulness of combination of metformin and hormonal contraceptives has been examined with reassuring results.<sup>601</sup> While it is plausible that metformin use may mitigate the risk for heart disease in women with PCOS using hormonal contraceptives, any conclusive evidence in this regard is lacking.<sup>602</sup> As mentioned earlier in the chapter, metformin does have a role in women with PCOS who also have NAFLD.

# Additional Considerations

## Adolescent with PCOS

The diagnosis of PCOS in adolescence presents a challenge to clinicians, as some of the features that are weighed among diagnostic criteria in adults are commonly encountered features of normal adolescent development, such as some degree of menstrual irregularity particularly within the first year postmenarche and acne.<sup>285</sup> Early pubarche or adrenarche have been associated with development of PCOS later in life, although the mechanisms are not clear.<sup>603</sup> Menstrual cycles are often longer during the first 3 years following menarche, becoming progressively more regular so that by the 3rd year following menarche, less than 50% of cycles remain irregular. Acne can also be a normal feature of puberty and polycystic appearance of ovaries may be normal for an adolescent female. However, menstrual irregularity persisting beyond 3 years postmenarche likely indicates a true ovarian or adrenal dysfunction and should be investigated.<sup>285</sup> Overall, a consensus exists in the recommendation for following adolescent patients closely for 2 years postmenarche prior to initiating an investigation for PCOS. In working up the possible diagnosis of PCOS in adolescents, the following should be used to help facilitate diagnosis:

- **Hyperandrogenism:** Hirsutism is the hallmark of hyperandrogenism, with acne and alopecia suggesting hyperandrogenism. In adolescent girls, the prevalence of acne is high and may be unrelated to PCOS. Hirsutism is also difficult to identify/quantify, as the Ferriman-Gallwey score was designed for testing in adult women. As such, in this younger patient population, there is emphasis placed on biochemical signs of excess androgens. Reference range for normal and abnormal values for testosterone in adolescents is not well defined; the lower “normal” limit in adolescents is likely lower than that in adult women,<sup>604</sup> and a transient increase in circulating levels of testosterone may be a physiologic pubertal phenomenon.<sup>605</sup>
- Given that multifollicular ovaries are a normal feature in adolescence, this alone cannot be used as a diagnostic criterion for PCOS in adolescents.<sup>285</sup>
- In general, PCOS diagnosis in adolescents must require the presence of either primary amenorrhea at and beyond 16 years of age (ruling out other causes as discussed in [Chapter 10](#)) or persistent oligomenorrhea.<sup>349</sup>

Although difficult, the diagnosis of PCOS in adolescence is important, so that long-term health consequences can be mitigated. As such, anovulatory adolescent girls are another group that warrants periodic screening for glucose intolerance and specific screening for insulin resistance, particularly if they are obese or had low birth weight.<sup>606,607</sup> Both



characteristics are associated with premature adrenarche and the development of PCOS during adolescence, and evidence indicates that hyperinsulinemia is a key pathogenic factor.<sup>341,342,344,345</sup> There is substantial evidence that early treatment with metformin can decrease hyperinsulinemia and hyperandrogenism, facilitate weight loss, and restore ovulatory menstrual function in girls with demonstrable insulin resistance.<sup>285,343,345</sup> The addition of combined hormonal oral contraceptives to metformin has also been associated with increased HDL, although also with a trend toward increased triglycerides. In adolescents not interested in hormonal therapy, metformin alone is reasonable. An antiandrogen can also help treat more bothersome acne and hirsutism in the adolescents; however, such a regimen must include a reliable contraceptive, given the teratogenic potential of antiandrogenic formulations.<sup>285</sup>

## **PCOS, Reproductive Aging, and Menopause**

There is a paucity of information on experiences of women with PCOS as they progress through stages of reproductive aging. Limited data however suggest that age at spontaneous menopause is likely delayed in women with PCOS.<sup>608</sup> Interestingly, with aging, the pattern of menstrual cycles often becomes regular and predictable with an increase in frequency of spontaneous anovulatory cycles. In a prospective cohort study, 118 hyperandrogenic women with PCOS were followed from ages 20 to 25 at 5-year intervals for 20 years, and their clinical, endocrine, and metabolic profiles were compared with two different groups of age-comparable controls without PCOS. In the PCOS population, the proportion of anovulatory cycles decreased from 100% at the start of this study to 73% by the time participants reached ages between 40 and 44 years.<sup>609</sup> Notably, in women with PCOS whose cycles became ovulatory with advancing age, the metabolic indices of insulin sensitivity and lipid profiles were comparable to seen in the controls; in contrast, PCOS women who remained anovulatory demonstrated evidence of dysmetabolism including higher insulin levels, lower QUICKI (reflecting insulin resistance), and worse lipid profiles (higher total C, LDL-C, non-HDL-C, and lower HDL-C). While resumption of spontaneous ovulatory cycles with advancing age confers endometrial and metabolic benefit, this shift in reproductive physiology does increase a likelihood of unplanned pregnancies for women with PCOS as they age; a greater appreciation of a need for reliable contraception is needed as women with PCOS age. As discussed earlier, women with PCOS are at a higher lifetime risk for developing endometrial cancer, and therefore new-onset abnormal uterine bleeding must be thoroughly evaluated in women with a history of PCOS. Their risk for breast and ovarian cancer is no higher than age-comparable women without PCOS. Long-term longitudinal studies are needed to better understand if women with PCOS view and experience menopause transition and postmenopausal period differently than those without PCOS.

## **PCOS and Psychological Well-Being**

Anxiety and depression are common in women with PCOS, more so than in the general population.<sup>25</sup> These mood disorders can have significant impact on quality of life. For adolescence, self-image can be impacted, while in women facing infertility, there can be a high level of anxiety regarding potential inability to conceive. Self-image in women of all ages can be negatively impacted as well. It is important to screen for anxiety and depression, and adolescents and women with PCOS should be encouraged to identify and seek resources to optimize psychological well-being.

# SUMMARY

---

We clearly are in an era of increasing understanding of both determinants and sequelae of PCOS, as well as are gaining access to an expanding range of options for the management of women with PCOS. In the past, we primarily prioritized treatment of the specific problems of infertility, abnormal uterine bleeding, and hirsutism. We now have a better understanding of the endocrine and metabolic corollaries and of their relevance to long-term health risks and have greater management options and opportunities, and indeed the obligation, to choose and offer interventions that can maximize benefits while helping prevent or reverse some of the metabolic consequences of the disorder that have an important impact on overall health and on the quality and quantity of life.

## Key Points: PCOS

- Polycystic ovary syndrome is not a specific endocrine disease but a syndrome represented by a collection of signs and symptoms, and no one sign, symptom, or test is diagnostic.
- Diagnosis of polycystic ovary syndrome is based primarily on the clinical history and physical examination. The major clinical features of polycystic ovary syndrome are hyperandrogenism and menstrual dysfunction.
- Although present in most women with chronic hyperandrogenic anovulation, polycystic ovaries do not establish and are not required for diagnosis of polycystic ovary syndrome.
- Insulin resistance and compensatory hyperinsulinemia are common in women and play an important role in the pathophysiology of polycystic ovary syndrome. Up to 35% of women with polycystic ovary syndrome exhibit impaired glucose tolerance and up to 10% meet criteria for type 2 diabetes mellitus.
- Gonadotropin levels or ratios are not a reliable criterion for diagnosis of polycystic ovary syndrome.
- Knowing and understanding the health implications and consequences of chronic anovulation and methods for their effective management are far more important than simply assigning a diagnosis of PCOS.
- Evaluation of women with suspected polycystic ovary syndrome should include:
  - Serum thyroid-stimulating hormone (TSH).
  - Serum prolactin.
  - 2-hour oral glucose tolerance test.
  - Fasting lipid profile.
  - Serum testosterone (in women with clinical evidence of hyperandrogenism).
  - Morning follicular phase serum 17-hydroxyprogesterone (in women with a

pre- or perimenarcheal onset of hirsutism, a family history of congenital adrenal hyperplasia, or high-risk ethnicity).

- Screening for hypercortisolism (by 24-hour urine-free cortisol estimation) should be considered in women with features suggestive of Cushing syndrome (obesity, hypertension, diabetes, easy bruising).
- Overnight dexamethasone suppression test should be considered in women with signs, symptoms, or biochemical evidence of hypercortisolism).

# REFERENCES

1. **Schlechte J, Sherman B, Halmi N, VanGilder J, Chapler F, Dolan K, Granner D, Duello T, Harris C**, Prolactin-secreting pituitary tumors in amenorrheic women: a comprehensive study, *Endocr Rev* 1:295, 1980.
2. **Matsuzaki T, Azuma K, Irahara M, Yasui T, Aono T**, Mechanism of anovulation in hyperprolactinemic amenorrhea determined by pulsatile gonadotropin-releasing hormone injection combined with human chorionic gonadotropin, *Fertil Steril* 62:1143, 1994.
3. **Sonigo C, Bouilly J, Carre N**, et al., Hyperprolactinemia-induced ovarian acyclicity is reversed by kisspeptin administration, *J Clin Invest* 122:3791, 2012.
4. **Corenblum B, Pairedeau N, Shewchuk AB**, Prolactin hypersecretion and short luteal phase defects, *Obstet Gynecol* 47:486, 1976.
5. **Biller BM, Baum HB, Rosenthal DI, Saxe VC, Charpie PM, Klibanski A**, Progressive trabecular osteopenia in women with hyperprolactinemic amenorrhea, *J Clin Endocrinol Metabol* 75:692, 1992.
6. **Schlechte J, Walkner L, Kathol M**, A longitudinal analysis of premenopausal bone loss in healthy women and women with hyperprolactinemia, *J Clin Endocrinol Metabol* 75:698, 1992.
7. **Waldstreicher J, Santoro NF, Hall JE, Filicori M, Crowley WF**, Hyperfunction of the hypothalamic-pituitary axis in women with polycystic ovarian disease: indirect evidence for partial gonadotroph desensitization, *J Clin Endocrinol Metabol* 66:165, 1988.
8. **Taylor AE, McCourt B, Martin KA**, et al., Determinants of abnormal gonadotropin secretion in clinically defined women with polycystic ovary syndrome 1, *J Clin Endocrinol Metabol* 82:2248, 1997.
9. **Barnes RB, Lobo RA**, Central opioid activity in polycystic ovary syndrome with and without dopaminergic modulation, *J Clin Endocrinol Metabol* 61:779, 1985.
10. **Barnes RB, Rosenfield RL, Ehrmann DA**, et al., Ovarian hyperandrogenism as a result of congenital adrenal virilizing disorders: evidence for perinatal masculinization of neuroendocrine function in women, *J Clin Endocrinol Metabol* 79:1328, 1994.
11. **Zhou R, Bird IM, Dumesic DA, Abbott DH**, Adrenal hyperandrogenism is induced by fetal androgen excess in a rhesus monkey model of polycystic ovary syndrome, *J Clin Endocrinol Metabol* 90:6630, 2005.
12. **Xita N, Tsatsoulis A**, Fetal programming of polycystic ovary syndrome by androgen excess: evidence from experimental, clinical, and genetic association studies, *J Clin Endocrinol Metabol* 91:1660, 2006.
13. **Nappi C, Meo R, Di Carlo C, Estraneo A, Bilo L**, Reduced fertility and neuroendocrine dysfunction in women with epilepsy, *Gynecol Endocrinol* 8:133, 1994.
14. **Bilo L, Meo R**, Epilepsy and polycystic ovary syndrome: where is the link? *Neurol Sci* 27:221, 2006.
15. **Siiteri PK, MacDonald PC**, Role of extraglandular estrogen in human endocrinology, In: Geyer SR, Astwood EB, Greep RO, eds. *Handbook of Physiology, Section 7, Endocrinology*, American Physiology Society, Washington, 1973, p. 615.
16. **Ridgway EC, Maloof F, Longcope C**, Androgen and oestrogen dynamics in hyperthyroidism, *J Endocrinol* 95:105, 1982.
17. **Longcope C, Abend S, Braverman LE, Emerson CH**, Androstenedione and estrone dynamics in hypothyroid women, *J Clin Endocrinol Metabol* 70:903, 1990.
18. **Tahboub R, Arafah BM**, Sex steroids and the thyroid, *Best Pract Res Clin Endocrinol Metab* 23:769, 2009.
19. **Narasaka T, Moriya T, Endoh M**, et al., 17. BETA.-hydroxysteroid dehydrogenase type 2 and dehydroepiandrosterone sulfotransferase in the human liver, *Endocr J* 47:697, 2000.
20. **Abbott DH, Bacha F**, Ontogeny of polycystic ovary syndrome and insulin resistance in utero and early childhood, *Fertil Steril* 100:2, 2013.
21. **Bates GW, Whitworth NS**, Effect of body weight reduction on plasma androgens in obese, infertile women, *Fertil Steril* 38:406, 1982.
22. **Pasquali R, Antenucci D, Casimirri F, Venturoli S, Paradisi R, Fabbri R, Balestra V, Melchionda N, Barbara L**, Clinical and hormonal characteristics of obese amenorrheic hyperandrogenic women before and after weight loss, *J Clin Endocrinol Metabol* 68:173, 1989.

23. **Guzick DS, Wing R, Smith D, Berga SL, Winters SJ**, Endocrine consequences of weight loss in obese, hyperandrogenic, anovulatory women, *Fertil Steril* 61:598, 1994.
24. **Huber-Buchholz MM, Carey DGP, Norman RJ**, Restoration of reproductive potential by lifestyle modification in obese polycystic ovary syndrome: role of insulin sensitivity and luteinizing hormone, *J Clin Endocrinol Metabol* 84:1470, 1999.
25. **Dumesic DA, Oberfield SE, Stener-Victorin E, Marshall JC, Laven JS, Legro RS**, Scientific statement on the diagnostic criteria, epidemiology, pathophysiology, and molecular genetics of polycystic ovary syndrome, *Endocr Rev* 36:487, 2015.
26. **Knochenhauer ES, Key TJ, Kahsar-Miller M, Waggoner W, Boots LR, Azziz R**, Prevalence of the polycystic ovary syndrome in unselected black and white women of the southeastern united states: a prospective study, *J Clin Endocrinol Metabol* 83:3078, 1998.
27. **Asunción M, Calvo RM, San Millán JL, Sancho J, Avila S, Escobar-Morreale HF**, A prospective study of the prevalence of the polycystic ovary syndrome in unselected Caucasian women from Spain, *J Clin Endocrinol Metabol* 85:2434, 2000.
28. **Fogue E, Massabuau G**, L'ovaire a petits kystes, *Rev Gynecol Chirurg Abdom* 14:97, 1910.
29. **Stein IF, Leventhal ML**, Amenorrhea associated with bilateral polycystic ovaries, *Am J Obstet Gynecol* 29:181, 1935.
30. **Speert H**, *Obstetrics & Gynecologic Milestones Illustrated*, The Parthenon Publishing Group, New York, 1996.
31. **Hughesdon PE**, Morphology and morphogenesis of the stein-leventhal ovary and of so-called "hyperthecosis", *Obstet Gynecol Surv* 37:59, 1982.
32. **Johnstone EB, Rosen MP, Neril R, et al.**, The polycystic ovary post-rotterdam: a common, age-dependent finding in ovulatory women without metabolic significance, *J Clin Endocrinol Metab* 95:4965, 2010.
33. **Zawadski JK, Dunaif A**, Diagnostic criteria for polycystic ovary syndrome: towards a rational approach, In: Givens JR, Haseltine FP, Merriam GR, eds. *Polycystic Ovary Syndrome*, Blackwell Scientific Publications, Boston, 1992, p. 377.
34. **Raj SG, Thompson IE, Berger MJ, Talert LM, Taymor ML**, Diagnostic value of androgen measurements in polycystic ovary syndrome, *Obstet Gynecol* 52:169, 1978.
35. **Kyritsi EM, Dimitriadis GK, Kyrou I, Kaltsas G, Randeve HS**, PCOS remains a diagnosis of exclusion: a concise review of key endocrinopathies to exclude, *Clin Endocrinol (Oxf)* 86(1): 1–6, 2017. doi: 10.1111/cen.13245. Epub 2016 Oct 11. Review.
36. **Rotterdam ESHRE/ASRM-Sponsored PCOS Consensus Workshop Group**, Revised 2003 consensus on diagnostic criteria and long-term health risks related to polycystic ovary syndrome, *Fertil Steril* 81:19, 2004.
37. **Rotterdam ESHRE/ASRM-Sponsored PCOS Consensus Workshop Group**, Revised 2003 consensus on diagnostic criteria and long-term health risks related to polycystic ovary syndrome (PCOS), *Hum Reprod* 19:41, 2004.
38. **Azziz R, Carmina E, Dewailly D, Diamanti-Kandarakis E, Escobar-Morreale HF, Futterweit W, Janssen OE, Legro RS, Norman RJ, Taylor AE, Witchel SF; Task Force on the Phenotype of the Polycystic Ovary Syndrome of The Androgen Excess and PCOS Society**, The Androgen Excess and PCOS Society criteria for the polycystic ovary syndrome: the complete task force report, *Fertil Steril* 91:456, 2009.
39. **Dewailly D, Lujan ME, Carmina E, et al.**, Definition and significance of polycystic ovarian morphology: a task force report from the Androgen Excess and Polycystic Ovary Syndrome Society, *Hum Reprod Update* 20:334, 2014.
40. **Carmina E, Chu MC, Longo RA, Rini GB, Lobo RA**, Phenotypic variation in hyperandrogenic women influences the findings of abnormal metabolic and cardiovascular risk parameters, *J Clin Endocrinol Metab* 90:2545, 2005.
41. **Welt CK, Gudmundsson JA, Arason G, et al.**, Characterizing discrete subsets of polycystic ovary syndrome as defined by the Rotterdam criteria: the impact of weight on phenotype and metabolic features, *J Clin Endocrinol Metab* 91:4842, 2006.
42. **Anti-Mullerian Hormone: Role in Ovarian Function and Clinical Significance**. *Obstetrics and Gynecology*

Advances, Nova Science, New York, 2016.

43. **Bozdag G, Mumusoglu S, Zengin D, Karabulut E, Yildiz BO**, The prevalence and phenotypic features of polycystic ovary syndrome: a systematic review and meta-analysis, *Hum Reprod* 31:2841, 2016.
44. **Chang RJ**, Ovarian steroid secretion in polycystic ovarian disease, *Semin Reprod Med* 2:244, 1984.
45. **Dunaif A, Green G, Futterweit W, Dobrjansky A**, Suppression of hyperandrogenism does not improve peripheral or hepatic insulin resistance in the polycystic ovary syndrome, *J Clin Endocrinol Metabol* 70:699, 1990.
46. **Gonzalez F, Hatala DA, Speroff L**, Adrenal and ovarian steroid hormone responses to gonadotropin-releasing hormone agonist treatment in polycystic ovary syndrome, *Am J Obstet Gynecol* 165:535, 1991.
47. **Gonzalez F, Chang L, Horab T, Lobo RA**, Evidence for heterogeneous etiologies of adrenal dysfunction in polycystic ovary syndrome, *Fertil Steril* 66:354, 1996.
48. **Venturoli S, Porcu E, Fabbri R, Magrini O, Gammi L, Paradisi R, Forcacci M, Bolzani R, Flamigni C**, Episodic pulsatile secretion of FSH, LH, prolactin, oestradiol, oestrone, and LH circadian variations in polycystic ovary syndrome, *Clin Endocrinol (Oxf)* 28:93, 1988.
49. **Wajchenberg BL, Achando SS, Mathor MM, Czeresnia CE, Giannella Neto D, Kirschner MA**, The source(s) of estrogen production in hirsute women with polycystic ovarian disease as determined by simultaneous adrenal and ovarian venous catheterization, *Fertil Steril* 49:56, 1988.
50. **Fausser BC**, Observations in favor of normal early follicle development and disturbed dominant follicle selection in polycystic ovary syndrome, *Gynecol Endocrinol* 8:75, 1994.
51. **Geist SH**, Reaction of the mature human ovary to antuitrin-s, *Am J Obstet Gynecol* 26:588, 1933.
52. **Keettel WC, Bradbury JT, Stoddard FJ**, Observations on the polycystic ovary syndrome, *Am J Obstet Gynecol* 73:954, 1957.
53. **McArthur JW, Ingersoll FM, Worcester J**, The urinary excretion of interstitial-cell and follicle-stimulating hormone activity by women with diseases of the reproductive system, *J Clin Endocrinol Metabol* 18:1202, 1958.
54. **Ingersoll FM, McArthur JW**, Longitudinal studies of gonadotropin excretion in the Stein-Leventhal syndrome, *Am J Obstet Gynecol* 77:795, 1959.
55. **Taymor ML, Barnard R**, Luteinizing hormone excretion in the polycystic ovary syndrome, *Fertil Steril* 13:501, 1962.
56. **Yen SS, Vela P, Rankin J**, Inappropriate secretion of follicle-stimulating hormone and luteinizing hormone in polycystic ovarian disease, *J Clin Endocrinol Metabol* 30:435, 1970.
57. **Rebar R, Judd HL, Yen SS, Rakoff J, Vandenberg G, Naftolin F**, Characterization of the inappropriate gonadotropin secretion in polycystic ovary syndrome, *J Clin Investig* 57:1320, 1976.
58. **Balen AH**, Hypersecretion of luteinizing hormone and the polycystic ovary syndrome, *Hum Reprod* 8:123, 1993.
59. **Kazer RR, Kessel B, Yen SS**, Circulating luteinizing hormone pulse frequency in women with polycystic ovary syndrome, *J Clin Endocrinol Metabol* 65:233, 1987.
60. **Imse V, Holzapfel G, Hinney B, Kuhn W, Wuttke W**, Comparison of luteinizing hormone pulsatility in the serum of women suffering from polycystic ovarian disease using a bioassay and five different immunoassays, *J Clin Endocrinol Metabol* 74:1053, 1992.
61. **Hayes FJ, Taylor AE, Martin KA, Hall JE**, Use of a gonadotropin-releasing hormone antagonist as a physiologic probe in polycystic ovary syndrome: assessment of neuroendocrine and androgen dynamics, *J Clin Endocrinol Metabol* 83:2343, 1998.
62. **Lockwood GM, Muttukrishna S, Groome NP, Matthews DR, Ledger WL**, Mid-follicular phase pulses of inhibin B are absent in polycystic ovarian syndrome and are initiated by successful laparoscopic ovarian diathermy: a possible mechanism regulating emergence of the dominant follicle, *J Clin Endocrinol Metabol* 83:1730, 1998.
63. **Laven JSE**, Absent biologically relevant associations between serum inhibin B concentrations and characteristics of polycystic ovary syndrome in normogonadotrophic anovulatory infertility, *Hum Reprod* 16:1359, 2001.
64. **Wildt L, HÄUslar A, Marshall G, et al.**, Frequency and amplitude of gonadotropin-releasing hormone

- stimulation and gonadotropin secretion in the rhesus monkey, *Endocrinology* 109:376, 1981.
65. **Gross KM, Matsumoto AM, Bremner WJ**, Differential control of luteinizing hormone and follicle-stimulating hormone secretion by luteinizing hormone-releasing hormone pulse frequency in man, *J Clin Endocrinol Metabol* 64:675, 1987.
  66. **Spratt DI, Finkelstein JS, Butler JP, Badger TM, Crowley WF**, Effects of increasing the frequency of low doses of gonadotropin-releasing hormone (GnRH) on gonadotropin secretion in GnRH-deficient men, *J Clin Endocrinol Metabol* 64:1179, 1987.
  67. **Arroyo A**, Inappropriate gonadotropin secretion in polycystic ovary syndrome: influence of adiposity, *J Clin Endocrinol Metab* 82:3728, 1997.
  68. **Lobo RA, Kletzky OA, Campeau JD, diZerega GS**, Elevated bioactive luteinizing hormone in women with the polycystic ovary syndrome, *Fertil Steril* 39:674, 1983.
  69. **Mavroudis K, Evans A, Mamtora H, Anderson DC, Robertson WR**, Bioactive LH in women with polycystic ovaries and the effect of gonadotrophin suppression, *Clin Endocrinol (Oxf)* 29:633, 1988.
  70. **Fausser BC, Pache TD, Lamberts SW, Hop WC, de Jong FH, Dahl KD**, Serum bioactive and immunoreactive luteinizing hormone and follicle-stimulating hormone levels in women with cycle abnormalities, with or without polycystic ovarian disease, *J Clin Endocrinol Metabol* 73:811, 1991.
  71. **Blank SK, McCartney CR, Marshall JC**, The origins and sequelae of abnormal neuroendocrine function in polycystic ovary syndrome, *Hum Reprod Update* 12:351, 2006.
  72. **Buvat J, Buvat-Herbaut M, Marcolin G, et al.**, A double blind controlled study of the hormonal and clinical effects of bromocriptine in the polycystic ovary syndrome, *J Clin Endocrinol Metabol* 63:119, 1986.
  73. **Murdoch AP, McClean KG, Watson MJ, Dunlop W, Taylor PK**, Treatment of hirsutism in polycystic ovary syndrome with bromocriptine, *BJOG* 94:358, 1987.
  74. **Berga SL, Yen SS**, Opioidergic regulation of LH pulsatility in women with polycystic ovary syndrome, *Clin Endocrinol (Oxf)* 30:177, 1989.
  75. **Quigley ME, Yen SS**, The role of endogenous opiates on LH secretion during the menstrual cycle, *J Clin Endocrinol Metabol* 51:179, 1980.
  76. **Wardlaw SL, Wehrenberg WB, Ferin M, Antunes JL, Frantz AG**, Effect of sex steroids on  $\beta$ -endorphin in hypophyseal portal blood, *J Clin Endocrinol Metabol* 55:877, 1982.
  77. **Soules MR, Steiner RA, Clifton DK, Cohen NL, Aksel S, Bremner WJ**, Progesterone modulation of pulsatile luteinizing hormone secretion in normal women, *J Clin Endocrinol Metabol* 58:378, 1984.
  78. **Sullivan SD, Moenter SM**, Prenatal androgens alter GABAergic drive to gonadotropin-releasing hormone neurons: implications for a common fertility disorder, *Proc Natl Acad Sci U S A* 101:7129, 2004.
  79. **Dunaif A, Graf M**, Insulin administration alters gonadal steroid metabolism independent of changes in gonadotropin secretion in insulin-resistant women with the polycystic ovary syndrome, *J Clin Investig* 83:23, 1989.
  80. **Patel K, Coffler MS, Dahan MH, Yoo RY, Lawson MA, Malcom PJ, Chang RJ**, Increased luteinizing hormone secretion in women with polycystic ovary syndrome is unaltered by prolonged insulin infusion, *J Clin Endocrinol Metabol* 88:5456, 2003.
  81. **Mehta RV, Patel KS, Coffler MS, et al.**, Luteinizing hormone secretion is not influenced by insulin infusion in women with polycystic ovary syndrome despite improved insulin sensitivity during pioglitazone treatment, *J Clin Endocrinol Metabol* 90:2136, 2005.
  82. **Eagleson CA, Bellows AB, Hu K, Gingrich MB, Marshall JC**, Obese patients with polycystic ovary syndrome: evidence that metformin does not restore sensitivity of the gonadotropin-releasing hormone pulse generator to inhibition by ovarian steroids, *J Clin Endocrinol Metabol* 88:5158, 2003.
  83. **Nestler JE**, Insulin regulation of human ovarian androgens, *Hum Reprod* 12(Suppl 1):53, 1997.
  84. **Chang RJ, Mandel FP, Lu JKH, Judd HL**, Enhanced disparity of gonadotropin secretion by estrone in women with polycystic ovarian disease, *J Clin Endocrinol Metabol* 54:490, 1982.
  85. **Dunaif A, Longcope C, Canick J, Badger T, Crowley WF, Bain RP**, The effects of the aromatase inhibitor A1-testolactone on gonadotropin release and steroid metabolism in polycystic ovarian disease, *J Clin Endocrinol Metabol* 60:773, 1985.



86. **Daniels TL**, Resistance of gonadotropin releasing hormone drive to sex steroid-induced suppression in hyperandrogenic anovulation, *J Clin Endocrinol Metab* 82:4179, 1997.
87. **Pastor CL, Griffin-Korf ML, Aloï JA, Evans WS, Marshall JC**, Polycystic ovary syndrome: evidence for reduced sensitivity of the gonadotropin-releasing hormone pulse generator to inhibition by estradiol and progesterone, *J Clin Endocrinol Metabol* 83:582, 1998.
88. **Chhabra S, McCartney CR, Yoo RY, Eagleson CA, Chang RJ, Marshall JC**, Progesterone inhibition of the hypothalamic gonadotropin-releasing hormone pulse generator: evidence for varied effects in hyperandrogenemic adolescent girls, *J Clin Endocrinol Metabol* 90:2810, 2005.
89. **Egleson CA, Gingrich MB, Pastor CL, Arora TK, Burt CM, Evans WS, Marshall JC**, Polycystic ovarian syndrome: evidence that flutamide restores sensitivity of the gonadotropin-releasing hormone pulse generator to inhibition by estradiol and progesterone, *J Clin Endocrinol Metabol* 85:4047, 2000.
90. **Dumesic DA, Abbott DH, Eisner JR, Goy RW**, Prenatal exposure of female rhesus monkeys to testosterone propionate increases serum luteinizing hormone levels in adulthood, *Fertil Steril* 67:155, 1997.
91. **Robinson JE**, In utero exposure of female lambs to testosterone reduces the sensitivity of the GnRH neuronal network to inhibition by progesterone, *Endocrinology* 140:5797, 1999.
92. **Foecking EM, Szabo M, Schwartz NB, Levine JE**, Neuroendocrine consequences of prenatal androgen exposure in the female rat: absence of luteinizing hormone surges, suppression of progesterone receptor gene expression, and acceleration of the gonadotropin-releasing hormone pulse generator, *Biol Reprod* 72:1475, 2005.
93. **Abbott DH, Barnett DK, Bruns CM, Dumesic DA**, Androgen excess fetal programming of female reproduction: a developmental aetiology for polycystic ovary syndrome? *Hum Reprod Update* 11:357, 2005.
94. **Chang RJ, Laufer LR, Meldrum DR**, et al., Steroid secretion in polycystic ovarian disease after ovarian suppression by a long-acting gonadotropin-releasing hormone agonist, *J Clin Endocrinol Metabol* 56:897, 1983.
95. **Archard C, Thiers J**, Le virilisme pileire et son association a l'insuffisance glycolytique (diabete des femmes a barbe). *Bull Acad Natl Med* 86, 1921.
96. **Kahn CR, Rosenthal AS**, Immunologic reactions to insulin: insulin allergy, insulin resistance, and the autoimmune insulin syndrome, *Diabetes Care* 2:283, 1979.
97. **Kahn CR, Flier JS, Bar RS, Archer JA, Gorden P, Martin MM, Roth J**, The syndromes of insulin resistance and acanthosis nigricans, *N Engl J Med* 294:739, 1976.
98. **Tsiodras S, Mantzoros C, Hammer S, Samore M**, Effects of protease inhibitors on hyperglycemia, hyperlipidemia, and lipodystrophy, *Arch Intern Med* 160:2050, 2000.
99. **Musso C, Cochran E, Moran SA, Skarulis MC, Oral EA, Taylor S, Gorden P**, Clinical course of genetic diseases of the insulin receptor (type A and Rabson-Mendenhall syndromes), *Medicine* 83:209, 2004.
100. **Burghen GA, Givens JR, Kitabchi AE**, Correlation of hyperandrogenism with hyperinsulinism in polycystic ovarian disease, *J Clin Endocrinol Metabol* 50:113, 1980.
101. **Carmina E, Koyama T, Chang L, Stanczyk FZ, Lobo RA**, Does ethnicity influence the prevalence of adrenal hyperandrogenism and insulin resistance in polycystic ovary syndrome? *Am J Obstet Gynecol* 167:1807, 1992.
102. **Dunaif A**, Insulin resistance and the polycystic ovary syndrome: mechanism and implications for pathogenesis, *Endocr Rev* 18:774, 1997.
103. **Legro RS**, A fasting glucose to insulin ratio is a useful measure of insulin sensitivity in women with polycystic ovary syndrome, *J Clin Endocrinol Metab* 83:2694, 1998.
104. **Book C-B, Dunaif A**, Selective insulin resistance in the polycystic ovary syndrome, *J Clin Endocrinol Metabol* 84:3110, 1999.
105. **Ciaraldi TP, el-Roeiy A, Madar Z, Reichart D, Olefsky JM, Yen SS**, Cellular mechanisms of insulin resistance in polycystic ovarian syndrome, *J Clin Endocrinol Metab* 75:577, 1992.
106. **Dunaif A, Wu X, Lee A, Diamanti-Kandarakis E**, Defects in insulin receptor signaling in vivo in the polycystic ovary syndrome (PCOS), *Am J Physiol Endocrinol Metab* 281:E392, 2001.
107. **Legro RS, Kunselman AR, Dodson WC, Dunaif A**, Prevalence and predictors of risk for type 2 diabetes mellitus and impaired glucose tolerance in polycystic ovary syndrome: a prospective, controlled study in 254

- affected women, *J Clin Endocrinol Metabol* 84:165, 1999.
108. **McCartney ChR, Marshall JC**, Polycystic ovary syndrome, *N Engl J Med* 375:1398, 2016.
  109. **Ehrmann DA, Barnes RB, Rosenfield RL, Cavaghan MK, Imperial J**, Prevalence of impaired glucose tolerance and diabetes in women with polycystic ovary syndrome, *Diabetes Care* 22:141, 1999.
  110. **Tok EC, Ertunc D, Evruke C, Dilek S**, The androgenic profile of women with non-insulin-dependent diabetes mellitus, *J Reprod Med* 49:746, 2004.
  111. **Moller DE, Flier JS**, Insulin resistance—mechanisms, syndromes, and implications, *N Engl J Med* 325:938, 1991.
  112. **Moller DE, Vidal-Puig A, Azziz R**, Severe Insulin-Resistance Hyperandrogenic Syndromes. *Contemporary Endocrinology*, Humana Press, pp. 129–138.
  113. **Baillargeon J-P**, Insulin action in polycystic ovary syndrome: in vivo and in vitro, In: Azziz R, ed. *The Polycystic Ovary Syndrome: Current Concepts on Pathogenesis and Clinical Care*, Springer, New York, pp. 43–68.
  114. **Nelson-Degrave VL, Wickenheisser JK, Hendricks KL**, et al., Alterations in mitogen-activated protein kinase kinase and extracellular regulated kinase signaling in theca cells contribute to excessive androgen production in polycystic ovary syndrome, *Mol Endocrinol* 19:379, 2005.
  115. **Nestler JE, Jakubowicz DJ, de Vargas AF, Brik C, Quintero N, Medina F**, Insulin stimulates testosterone biosynthesis by human thecal cells from women with polycystic ovary syndrome by activating its own receptor and using inositolglycan mediators as the signal transduction system, *J Clin Endocrinol Metabol* 83:2001, 1998.
  116. **Franks S, Gilling-Smith C, Watson H, Willis D**, Insulin action in the normal and polycystic ovary, *Endocrinol Metab Clin North Am* 28:361, 1999.
  117. **Willis D, Mason H, Gilling-Smith C, Franks S**, Modulation by insulin of follicle-stimulating hormone and luteinizing hormone actions in human granulosa cells of normal and polycystic ovaries, *J Clin Endocrinol Metabol* 81:302, 1996.
  118. **Smith S, Ravnkar VA, Barbieri RL**, Androgen and insulin response to an oral glucose challenge in hyperandrogenic women, *Fertil Steril* 48:72, 1987.
  119. **Nestler JE, Barlascini CO, Matt DW**, et al., Suppression of serum insulin by diazoxide reduces serum testosterone levels in obese women with polycystic ovary syndrome, *J Clin Endocrinol Metabol* 68:1027, 1989.
  120. **Plymate SR, Matej LA, Jones RE, Friedl KE**, Inhibition of sex hormone-binding globulin production in the human hepatoma (Hep G2) cell line by insulin and prolactin, *J Clin Endocrinol Metabol* 67:460, 1988.
  121. **Nestler JE, Powers LP, Matt DW, Steingold KA, Plymate SR, Rittmaster RS, Clore JN, Blackard WG**, A direct effect of hyperinsulinemia on serum sex hormone-binding globulin levels in obese women with the polycystic ovary syndrome, *J Clin Endocrinol Metabol* 72:83, 1991.
  122. **Cohen JC, Hickman R**, Insulin resistance and diminished glucose tolerance in powerlifters ingesting anabolic steroids, *J Clin Endocrinol Metabol* 64: 960, 1987.
  123. **Barbieri RL, Makris A, Ryan KJ**, Insulin stimulates androgen accumulation in incubations of human ovarian stroma and theca, *Obstet Gynecol* 64:73S, 1984.
  124. **Willis D, Franks S**, Insulin action in human granulosa cells from normal and polycystic ovaries is mediated by the insulin receptor and not the type-I insulin-like growth factor receptor, *J Clin Endocrinol Metabol* 80:3788, 1995.
  125. **Nestler J**, Role of hyperinsulinemia in the pathogenesis of the polycystic ovary syndrome, and its clinical implications, *Semin Reprod Med* 15:111, 1997.
  126. **Formuso C, Stracquadanio M, Ciotta L**, Myo-inositol vs. D-chiro inositol in PCOS treatment, *Minerva Ginecol* 67:321, 2015.
  127. **Monastra G, Unfer V, Harrath AH, Bizzarri M**, Combining treatment with myo-inositol and D-chiro-inositol (40:1) is effective in restoring ovary function and metabolic balance in PCOS patients, *Gynecol Endocrinol* 33:1, 2017.
  128. **Facchinetti F, Bizzarri M, Benvenga S**, et al., Results from the International Consensus Conference on Myo-inositol and D-chiro-inositol in obstetrics and gynecology: the link between metabolic syndrome and PCOS,

Eur J Obstet Gynecol Reprod Biol 195:72, 2015.

129. **Baptiste CG, Battista MC, Trottier A, Baillargeon JP**, Insulin and hyperandrogenism in women with polycystic ovary syndrome, *J Steroid Biochem Mol Biol* 122:42, 2010.
130. **Czech MP, Corvera S**, Signaling mechanisms that regulate glucose transport, *J Biol Chem* 274:1865, 1999.
131. **Bergman R, Ader M**, Free fatty acids and pathogenesis of type 2 diabetes mellitus, *Trends Endocrinol Metab* 11:351, 2000.
132. **Michael MD, Kulkarni RN, Postic C**, et al., Loss of insulin signaling in hepatocytes leads to severe insulin resistance and progressive hepatic dysfunction, *Mol Cell* 6:87, 2000.
133. **Anthonsen MW, Rönstrand L, Wernstedt C, Degerman E, Holm C**, Identification of novel phosphorylation sites in hormone-sensitive lipase that are phosphorylated in response to isoproterenol and govern activation properties in vitro, *J Biol Chem* 273:215, 1998.
134. **Berggreen C, Gormand A, Omar B, Degerman E, Goransson O**, Protein kinase B activity is required for the effects of insulin on lipid metabolism in adipocytes, *Am J Physiol Endocrinol Metab* 296:E635, 2009.
135. **Wu XK, Zhou SY, Liu JX**, et al., Selective ovary resistance to insulin signaling in women with polycystic ovary syndrome, *Fertil Steril* 80:954, 2003.
136. **Li M, Youngren JF, Dunaif A**, et al., Decreased insulin receptor (IR) autophosphorylation in fibroblasts from patients with PCOS: effects of serine kinase inhibitors and IR activators, *J Clin Endocrinol Metab* 87:4088, 2002.
137. **Diamanti-Kandarakis E, Papavassiliou AG**, Molecular mechanisms of insulin resistance in polycystic ovary syndrome, *Trends Mol Med* 12:324, 2006.
138. **Dunaif A, Xia J, Book CB, Schenker E, Tang Z**, Excessive insulin receptor serine phosphorylation in cultured fibroblasts and in skeletal muscle. A potential mechanism for insulin resistance in the polycystic ovary syndrome, *J Clin Invest* 96:801, 1995.
139. **Ciaraldi TP, Morales AJ, Hickman MG, Odom-Ford R, Olefsky JM, Yen SSC**, Cellular insulin resistance in adipocytes from obese polycystic ovary syndrome subjects involves adenosine modulation of insulin sensitivity, *J Clin Endocrinol Metab* 82:1421, 1997.
140. **Ek I, Arner P, Bergqvist A, Carlström K, Wahrenberg H**, Impaired adipocyte lipolysis in nonobese women with the polycystic ovary syndrome: a possible link to insulin resistance? *J Clin Endocrinol Metab* 82:1147, 1997.
141. **Tanti JF, Gual P, Grémeaux T, Gonzalez T, Barrès R, Le Marchand-Brustel Y**, Alteration in insulin action: role of IRS-1 serine phosphorylation in the retroregulation of insulin signalling, *Ann Endocrinol* 65:43, 2004.
142. **Morin-Papunen LC, Vauhkonen I, Koivunen RM, Ruukonen A, Tapanainen JS**, Insulin sensitivity, insulin secretion, and metabolic and hormonal parameters in healthy women and women with polycystic ovarian syndrome, *Hum Reprod* 15:1266, 2000.
143. **Holte J, Bergh T, Berne C, Wide L, Lithell H**, Restored insulin sensitivity but persistently increased early insulin secretion after weight loss in obese women with polycystic ovary syndrome, *J Clin Endocrinol Metab* 80:2586, 1995.
144. **Mai K, Bobbert T, Reinecke F**, et al., Intravenous lipid and heparin infusion-induced elevation in free fatty acids and triglycerides modifies circulating androgen levels in women: a randomized, controlled trial, *J Clin Endocrinol Metab* 93:3900, 2008.
145. **Pandey AV, Miller WL**, Regulation of 17,20 lyase activity by cytochrome b5 and by serine phosphorylation of P450c17, *J Biol Chem* 280:13265, 2005.
146. **Zhang LH, Rodriguez H, Ohno S, Miller WL**, Serine phosphorylation of human P450c17 increases 17,20-lyase activity: implications for adrenarche and the polycystic ovary syndrome, *Proc Natl Acad Sci* 92:10619, 1995.
147. **Dale PO, Tanbo T, Djøseland O, Jervell J, Abyholm T**, Persistence of hyperinsulinemia in polycystic ovary syndrome after ovarian suppression by gonadotropin-releasing hormone agonist, *Eur J Endocrinol* 126:132, 1992.
148. **Elkind-Hirsch KE, Valdes CT, Russell Malinak L**, Insulin resistance improves in hyperandrogenic women

treated with Lupron, *Fertil Steril* 60:634, 1993.

149. **Moggetti P, Tosi F, Castello R, Magnani CM, Negri C, Brun E, Furiani L, Caputo M, Muggeo M**, The insulin resistance in women with hyperandrogenism is partially reversed by antiandrogen treatment: evidence that androgens impair insulin action in women, *J Clin Endocrinol Metabol* 81:952, 1996.
150. **Iuorno MJ, Jakubowicz DJ, Baillargeon JP, Dillon P, Gunn RD, Allan G, Nestler JE**, Effects of D-chiro-inositol in lean women with the polycystic ovary syndrome, *Endocr Pract* 8:417, 2002.
151. **Baillargeon JP, Diamanti-Kandarakis E, Ostlund RE, Apridonidze T, Iuorno MJ, Nestler JE**, Altered D-chiro-inositol urinary clearance in women with polycystic ovary syndrome, *Diabetes Care* 29:300, 2006.
152. **Baillargeon JP, Nestler JE, Ostlund RE, Apridonidze T, Diamanti-Kandarakis E**, Greek hyperinsulinemic women, with or without polycystic ovary syndrome, display altered inositols metabolism, *Hum Reprod* 23:1439, 2008.
153. **Cheang KI, Baillargeon J-P, Essah PA**, et al., Insulin-stimulated release of D-chiro-inositol-containing inositolphosphoglycan mediator correlates with insulin sensitivity in women with polycystic ovary syndrome, *Metabolism* 57:1390, 2008.
154. **Korhonen S, Hippeläinen M, Niskanen L, Vanhala M, Saarikoski S**, Relationship of the metabolic syndrome and obesity to polycystic ovary syndrome: a controlled, population-based study, *Am J Obstet Gynecol* 184:289, 2001.
155. **Diamanti-Kandarakis E, Dunaif A**, Insulin resistance and the polycystic ovary syndrome revisited: an update on mechanisms and implications, *Endocr Rev* 33:981, 2012.
156. **Alvarez-Blasco F, Botella-Carretero JI, San Millan JL, Escobar-Morreale HF**, Prevalence and characteristics of the polycystic ovary syndrome in overweight and obese women, *Arch Intern Med* 166:2081, 2006.
157. **Yildiz BO, Yarali H, Oguz H, Bayraktar M**, Glucose intolerance, insulin resistance, and hyperandrogenemia in first degree relatives of women with polycystic ovary syndrome, *J Clin Endocrinol Metabol* 88:2031, 2003.
158. **Ehrmann DA, Liljenquist DR, Kasza K, Azziz R, Legro RS, Ghazzi MN**, Prevalence and predictors of the metabolic syndrome in women with polycystic ovary syndrome, *J Clin Endocrinol Metabol* 91:48, 2006.
159. **Dokras A, Jagasia DH, Maifeld M, Sinkey CA, VanVoorhis BJ, Haynes WG**, Obesity and insulin resistance but not hyperandrogenism mediates vascular dysfunction in women with polycystic ovary syndrome, *Fertil Steril* 86:1702, 2006.
160. **Barber TM, McCarthy MI, Wass JAH, Franks S**, Obesity and polycystic ovary syndrome, *Clin Endocrinol (Oxf)* 65:137, 2006.
161. **Boomsma CM, Eijkemans MJ, Hughes EG, Visser GH, Fauser BC, Macklon NS**, A meta-analysis of pregnancy outcomes in women with polycystic ovary syndrome, *Hum Reprod Update* 12:673, 2006.
162. **Carpentier AC**, Postprandial fatty acid metabolism in the development of lipotoxicity and type 2 diabetes, *Diabetes Metab* 34:97, 2008.
163. **Hotamisligil GS, Peraldi P, Budavari A, Ellis R, White MF, Spiegelman BM**, IRS-1-mediated inhibition of insulin receptor tyrosine kinase activity in TNF- $\alpha$ - and obesity-induced insulin resistance, *Science* 271:665, 1996.
164. **Poretsky L, Cataldo NA, Rosenwaks Z, Giudice LC**, The insulin-related ovarian regulatory system in health and disease, *Endocr Rev* 20:535, 1999.
165. **Svendsen PF, Nilas L, Norgaard K, Jensen JEB, Madsbad S**, Obesity, body composition and metabolic disturbances in polycystic ovary syndrome, *Hum Reprod* 23:2113, 2008.
166. **Yildirim B**, Relation of intra-abdominal fat distribution to metabolic disorders in nonobese patients with polycystic ovary syndrome, *Fertil Steril* 79:1358, 2003.
167. **Michelmores K, Ong K, Mason S**, et al., Clinical features in women with polycystic ovaries: relationships to insulin sensitivity, insulin gene VNTR and birth weight, *Clin Endocrinol (Oxf)* 55:439, 2001.
168. **Rebuffé-Scrive M, Cullberg G, Lundberg PA, Lindstedt G, Björntorp P**, Anthropometric variables and metabolism in polycystic ovarian disease, *Horm Metab Res* 21:391, 1989.
169. **Goyal M, Dawood AS**, Debates regarding lean patients with polycystic ovary syndrome: a narrative review, *J Hum Reprod Sci* 10:154, 2017.

170. **Carmina E, Rosato F, Janni A, Rizzo M, Longo RA**, Relative prevalence of different androgen excess disorders in 950 women referred because of clinical hyperandrogenism, *J Clin Endocrinol Metabol* 91:2, 2006.
171. **Azziz R, Sanchez LA, Knochenhauer ES, Moran C, Lazenby J, Stephens KC, Taylor K, Boots LR**, Androgen excess in women: experience with over 1000 consecutive patients, *J Clin Endocrinol Metabol* 89:453, 2004.
172. **Flegal KM, Carroll MD, Ogden CL, Curtin LR**, Prevalence and trends in obesity among US adults, 1999–2008, *JAMA* 303:235, 2010.
173. **Azziz R, Woods KS, Reyna R, Key TJ, Knochenhauer ES, Yildiz BO**, The prevalence and features of the polycystic ovary syndrome in an unselected population, *J Clin Endocrinol Metabol* 89:2745, 2004.
174. **Diamanti-Kandarakis E, Kouli CR, Bergiele AT, et al.**, A survey of the polycystic ovary syndrome in the Greek island of Lesbos: hormonal and metabolic profile, *J Clin Endocrinol Metabol* 84:4006, 1999.
175. **Michelmore KF, Balen AH, Dunger DB, Vessey MP**, Polycystic ovaries and associated clinical and biochemical features in young women, *Clin Endocrinol (Oxf)* 51:779, 1999.
176. **Yildiz BO, Knochenhauer ES, Azziz R**, Impact of obesity on the risk for polycystic ovary syndrome, *J Clin Endocrinol Metabol* 93:162, 2008.
177. **Gambineri A, Pelusi C, Vicennati V, Pagotto U, Pasquali R**, Obesity and the polycystic ovary syndrome, *Int J Obes (Lond)* 26:883, 2002.
178. **Pasquali R, Gambineri A, Pagotto U**, Review article: the impact of obesity on reproduction in women with polycystic ovary syndrome, *BJOG* 113: 1148, 2006.
179. **Hirschberg AL**, Polycystic ovary syndrome, obesity and reproductive implications, *Womens Health* 5:529, 2009.
180. **Plymate SR, Fariss BL, Bassett ML, Matej L**, Obesity and its role in poly cystic ovary syndrome, *J Clin Endocrinol Metabol* 52:1246, 1981.
181. **Baillargeon J-P, Nestler JE**, Polycystic ovary syndrome: a syndrome of ovarian hypersensitivity to insulin? *J Clin Endocrinol Metabol* 91:22, 2006.
182. **Linné Y**, Effects of obesity on women's reproduction and complications during pregnancy, *Obes Rev* 5:137, 2004.
183. **Kumar A, Woods KS, Bartolucci AA, Azziz R**, Prevalence of adrenal androgen excess in patients with the polycystic ovary syndrome (PCOS), *Clin Endocrinol (Oxf)* 62:644, 2005.
184. **Cedars MI, Steingold KA, de Ziegler D, Lapolt PS, Chang RJ, Judd HL**, Long-term administration of gonadotropin-releasing hormone agonist and dexamethasone: assessment of the adrenal role in ovarian dysfunction, *Fertil Steril* 57: 495, 1992.
185. **Barnes RB, Rosenfield RL, Burstein S, Ehrmann DA**, Pituitary-ovarian responses to nafarelin testing in the polycystic ovary syndrome, *N Engl J Med* 320:559, 1989.
186. **Nelson VL, Qin K-N, Rosenfield RL, et al.**, The biochemical basis for increased testosterone production in theca cells propagated from patients with polycystic ovary syndrome, *J Clin Endocrinol Metabol* 86:5925, 2001.
187. **Jakimiuk AJ, Weitsman SR, Navab A, Magoffin DA**, Luteinizing hormone receptor, steroidogenesis acute regulatory protein, and steroidogenic enzyme messenger ribonucleic acids are overexpressed in thecal and granulosa cells from polycystic ovaries, *J Clin Endocrinol Metabol* 86:1318, 2001.
188. **Nelson VL, Legro RS, Strauss JF III, McAllister JM**, Augmented androgen production is a stable steroidogenic phenotype of propagated theca cells from polycystic ovaries, *Mol Endocrinol* 13:946, 1999.
189. **Gilling-Smith C, Story H, Rogers V, Franks S**, Evidence for a primary abnormality of thecal cell steroidogenesis in the polycystic ovary syndrome, *Clin Endocrinol (Oxf)* 47:93, 1997.
190. **Ehrmann DA, Barnes RB, Rosenfield RL, Cavaghan MK, Imperial J**, Polycystic ovary syndrome as a form of functional ovarian hyperandrogenism due to dysregulation of androgen secretion, *Endocr Rev* 16:322, 1995.
191. **Wickenheisser JK, Nelson-DeGrave VL, McAllister JM**, Dysregulation of cytochrome P450 17 $\alpha$ -hydroxylase messenger ribonucleic acid stability in theca cells isolated from women with polycystic ovary syndrome, *J Clin Endocrinol Metabol* 90:1720, 2005.
192. **Doi SAR**, Neuroendocrine dysfunction in PCOS: a critique of recent reviews, *Clin Med Res* 6:47, 2008.

193. **Strauss JF**, Some new thoughts on the pathophysiology and genetics of polycystic ovary syndrome, *Ann N Y Acad Sci* 997:42, 2003.
194. **Azziz R, Black V, Hines GA, Fox LM, Boots LR**, Adrenal androgen excess in the polycystic ovary syndrome: sensitivity and responsivity of the hypothalamic-pituitary-adrenal axis, *J Clin Endocrinol Metab* 83:2317, 1998.
195. **Ehrmann DA, Rosenfield RL, Barnes RB, Brigell DF, Sheikh Z**, Detection of functional ovarian hyperandrogenism in women with androgen excess, *N Engl J Med* 327:157, 1992.
196. **Steingold K, De Ziegler D, Cedars M, Meldrum DR, Lu JK, Judd HL, Chang RJ**, Clinical and hormonal effects of chronic gonadotropin releasing hormone agonist treatment in polycystic ovarian disease, *J Clin Endocrinol Metabol* 65:773, 1987.
197. **Rosenfield RL, Fang VS**, The effects of prolonged physiologic estradiol therapy on the maturation of hypogonadal teen-agers, *J Pediatr* 85:830, 1974.
198. **Anderson DC, Yen SS**, Effects of estrogens on adrenal  $3\beta$ -hydroxysteroid dehydrogenase in ovariectomized women, *J Clin Endocrinol Metabol* 43:561, 1976.
199. **Rose DP, Fern M, Liskowski L, Milbrath JR**, Effect of treatment with estrogen conjugates on endogenous plasma steroids, *Obstet Gynecol* 49:80, 1977.
200. **Tazuke S, Khaw K-T, Barrett-Connor E**, Exogenous estrogen and endogenous sex hormones, *Medicine* 71:44, 1992.
201. **Moran C, Reyna R, Boots LS, Azziz R**, Adrenocortical hyperresponsiveness to corticotropin in polycystic ovary syndrome patients with adrenal androgen excess, *Fertil Steril* 81:126, 2004.
202. **Puurunen J, Piltonen T, Jaakkola P, Ruukonen A, Morin-Papunen L, Tapanainen JS**, Adrenal androgen production capacity remains high up to menopause in women with polycystic ovary syndrome, *J Clin Endocrinol Metab* 94:1973, 2009.
203. **Escobar-Morreale HF, Serrano-Gotarredona J, García-Robles R, Sancho JM, Varela C**, Lack of an ovarian function influence on the increased adrenal androgen secretion present in women with functional ovarian hyperandrogenism, *Fertil Steril* 67:654, 1997.
204. **Azziz R**, Adrenal androgen excess in women: lack of a role for 17-hydroxylase and 17,20-lyase dysregulation, *J Clin Endocrinol Metab* 80:400, 1995.
205. **Techatraisak K, Conway GS, Rumsby G**, Frequency of a polymorphism in the regulatory region of the 17 $\alpha$ -hydroxylase-17,20-lyase (CYP17) gene in hyperandrogenic states, *Clin Endocrinol (Oxf)* 46:131, 1997.
206. **Moggetti P, Castello R, Negri C, et al.**, Insulin infusion amplifies 17 alpha-hydroxycorticosteroid intermediates response to adrenocorticotropin in hyperandrogenic women: apparent relative impairment of 17,20-lyase activity, *J Clin Endocrinol Metabol* 81:881, 1996.
207. **Nestler JE, Clore JN, Strauss JF III, Blackard WG**, The effects of hyperinsulinemia on serum testosterone, progesterone, dehydroepiandrosterone sulfate, and cortisol levels in normal women and in a woman with hyperandrogenism, insulin resistance, and acanthosis nigricans, *J Clin Endocrinol Metabol* 64:180, 1987.
208. **Nestler JE, McClanahan MA, Clore JN, Blackard WG**, Insulin inhibits adrenal 17,20-lyase activity in man, *J Clin Endocrinol Metabol* 74:362, 1992.
209. **l'Allemand D, Penhoat A, Lebrethon MC, et al.**, Insulin-like growth factors enhance steroidogenic enzyme and corticotropin receptor messenger ribonucleic acid levels and corticotropin steroidogenic responsiveness in cultured human adrenocortical cells, *J Clin Endocrinol Metabol* 81:3892, 1996.
210. **Kristiansen SB, Endoh A, Casson PR, Buster JE, Hornsby PJ**, Induction of steroidogenic enzyme genes by insulin and IGF-I in cultured adult human adrenocortical cells, *Steroids* 62:258, 1997.
211. **Erickso GF, Hsueh AJW, Quigley ME, Rebar RW, Yen SSC**, Functional studies of aromatase activity in human granulosa cells from normal and polycystic ovaries, *J Clin Endocrinol Metabol* 49:514, 1979.
212. **Erickson GF, Magoffin DA, Garzo VG, Cheung AP, Chang RJ**, Granulosa cells of polycystic ovaries: are they normal or abnormal? *Hum Reprod* 7:293, 1992.
213. **Mason HD, Margara R, Winston RM, Seppala M, Koistinen R, Franks S**, Insulin-like growth factor-I (IGF-I) inhibits production of IGF-binding protein-1 while stimulating estradiol secretion in granulosa cells from

normal and polycystic human ovaries, *J Clin Endocrinol Metabol* 76:1275, 1993.

214. **Almahbobi G, Anderiesz C, Hutchinson P, McFarlane JR, Wood C, Trounson AO**, Functional integrity of granulosa cells from polycystic ovaries, *Clin Endocrinol (Oxf)* 44:571, 1996.
215. **Judd HL, Rigg LA, Anderson DC, Yen SSC**, The effects of ovarian wedge resection on circulating gonadotropin and ovarian steroid levels in patients with polycystic ovary syndrome, *J Clin Endocrinol Metabol* 43:347, 1976.
216. **Mahesh VB, Toledo SP, Mattar E**, Hormone levels following wedge resection in polycystic ovary syndrome, *Obstet Gynecol* 51:64s, 1978.
217. **Maurice K, Carr PJ, Cohen BM, Millar RP**, Hormonal effects of wedge resection of polycystic ovaries, *Obstet Gynecol* 51:437, 1978.
218. **Casper R, Greenblatt E**, Laparoscopic ovarian cautery for induction of ovulation in women with polycystic ovarian disease, *Semin Reprod Med* 8:208, 1990.
219. **Kaaijk EM**, Clinical outcome after unilateral oophorectomy in patients with polycystic ovary syndrome, *Hum Reprod* 14:889, 1999.
220. **Kase N, Kowal J, Perloff W, Soffer LJ**, In vitro production of androgens by a virilizing adrenal adenoma and associated polycystic ovaries. *Eur J Endocrinol* 44:15, 1963.
221. **Zourlas PA, Jones HW Jr**, Stein-Leventhal syndrome with masculinizing ovarian tumors. Report of 3 cases, *Obstet Gynecol* 34:861, 1969.
222. **Dunaif A, Scully RE, Andersen RN, Chapin DS, Crowley WF Jr**, The effects of continuous androgen secretion on the hypothalamic-pituitary axis in woman: evidence from a luteinized thecoma of the ovary, *J Clin Endocrinol Metabol* 59:389, 1984.
223. **Amirikia H, Savoy-Moore RT, Sundareson AS, Moghissi KS**, The effects of long-term androgen treatment on the ovary, *Fertil Steril* 45:202, 1986.
224. **Pache TD, Fauser BC**, Polycystic ovaries in female-to-male transsexuals, *Clin Endocrinol (Oxf)* 39:702, 1993.
225. **Carey AH, Chan KL, Short F, White D, Williamson R, Franks S**, Evidence for a single gene effect causing polycystic ovaries and male pattern baldness, *Clin Endocrinol (Oxf)* 38:653, 1993.
226. **Govind A**, Polycystic ovaries are inherited as an autosomal dominant trait: analysis of 29 polycystic ovary syndrome and 10 control families, *J Clin Endocrinol Metab* 84:38, 1999.
227. **Norman RJ, Masters S, Hague W**, Hyperinsulinemia is common in family members of women with polycystic ovary syndrome, *Fertil Steril* 66:942, 1996.
228. **Hague WM, Adams J, Reeders ST, Peto TEA, Jacobs HS**, Familial polycystic ovaries: a genetic disease? *Clin Endocrinol (Oxf)* 29:593, 1988.
229. **Legro RS, Driscoll D, Strauss JF, Fox J, Dunaif A**, Evidence for a genetic basis for hyperandrogenemia in polycystic ovary syndrome, *Proc Natl Acad Sci* 95:14956, 1998.
230. **Kashar-Miller M, Azziz R**, Heritability and the risk of developing androgen excess, *J Steroid Biochem Mol Biol* 69:261, 1999.
231. **Kashar-Miller MD, Nixon C, Boots LR, Go RC, Azziz R**, Prevalence of polycystic ovary syndrome (PCOS) in first-degree relatives of patients with PCOS, *Fertil Steril* 75:53, 2001.
232. **Kaushal R, Parchure N, Bano G, Kaski JC, Nussey SS**, Insulin resistance and endothelial dysfunction in the brothers of Indian subcontinent Asian women with polycystic ovaries, *Clin Endocrinol (Oxf)* 60:322, 2004.
233. **Leibel NI, Baumann EE, Kocherginsky M, Rosenfield RL**, Relationship of adolescent polycystic ovary syndrome to parental metabolic syndrome, *J Clin Endocrinol Metabol* 91:1275, 2006.
234. **Franks S, Gharani N, Waterworth D**, et al., The genetic basis of polycystic ovary syndrome, *Hum Reprod* 12:2641, 1997.
235. **Waterworth DM, Bennett ST, Gharani N**, et al., Linkage and association of insulin gene VNTR regulatory polymorphism with polycystic ovary syndrome, *Lancet* 349:986, 1997.
236. **Witchel SF, Lee PA, Suda-Hartman M, Smith R, Hoffman EP**, 17 $\alpha$ -hydroxylase/17,20-lyase dysregulation is not caused by mutations in the coding regions of CYP17, *J Pediatr Adolesc Gynecol* 11:133, 1998.
237. **Urbanek M, Legro RS, Driscoll DA**, et al., Thirty-seven candidate genes for polycystic ovary syndrome:

strongest evidence for linkage is with follistatin, Proc Natl Acad Sci 96:8573, 1999.

238. **Diamanti-Kandarakis E, Bartzis MI, Bergiele AT, Tsianateli TC, Kouli CR**, Microsatellite polymorphism (tttta)<sub>n</sub> at -528 base pairs of gene CYP11 $\alpha$  influences hyperandrogenemia in patients with polycystic ovary syndrome, Fertil Steril 73:735, 2000.
239. **Kosova G, Urbanek M**, Genetics of the polycystic ovary syndrome, Mol Cell Endocrinol 373:29, 2013.
240. **McAllister JM, Modi B, Miller BA**, et al., Overexpression of a DENND1A isoform produces a polycystic ovary syndrome theca phenotype, Proc Natl Acad Sci U S A 111:E1519, 2014.
241. **Diamanti-Kandarakis E, Piperi C**, Genetics of polycystic ovary syndrome: searching for the way out of the labyrinth, Hum Reprod Update 11:631, 2005.
242. **Liu H, Zhao H, Chen ZJ**, Genome-wide association studies for polycystic ovary syndrome, Semin Reprod Med 34:224, 2016.
243. **Miller KK, Rosner W, Lee H**, et al., Measurement of free testosterone in normal women and women with androgen deficiency: comparison of methods, J Clin Endocrinol Metabol 89:525, 2004.
244. **Vermeulen A**, A critical evaluation of simple methods for the estimation of free testosterone in serum, J Clin Endocrinol Metab 84:3666, 1999.
245. **Van Uytfanghe K, Stöckl D, Kaufman JM, Fiers T, De Leenheer A, Thienpont LM**, Validation of 5 routine assays for serum free testosterone with a candidate reference measurement procedure based on ultrafiltration and isotope dilution-gas chromatography-mass spectrometry, Clin Biochem 38:253, 2005.
246. **Boots LR, Potter S, Potter HD, Azziz R**, Measurement of total serum testosterone levels using commercially available kits: high degree of between-kit variability, Fertil Steril 69:286, 1998.
247. **Van Uytfanghe K**, Evaluation of a candidate reference measurement procedure for serum free testosterone based on ultrafiltration and isotope dilution-gas chromatography-mass spectrometry, Clin Chem 50:2101, 2004.
248. **Södergard R, Bäckström T, Shanbhag V, Carstensen H**, Calculation of free and bound fractions of testosterone and estradiol-17 $\beta$  to human plasma proteins at body temperature, J Steroid Biochem 16:801, 1982.
249. **Martin KA, Chang RJ, Ehrmann DA**, et al., Evaluation and treatment of hirsutism in premenopausal women: an endocrine society clinical practice guideline, J Clin Endocrinol Metabol 93:1105, 2008.
250. **Azziz R, Fox LM, Zacur HA, Parker CR, Boots LR**, Adrenocortical secretion of dehydroepiandrosterone in healthy women: highly variable response to adrenocorticotropin, J Clin Endocrinol Metabol 86:2513, 2001.
251. **Lobo RA, Paul WL, Goebelsmann U**, Dehydroepiandrosterone sulfate as an indicator of adrenal androgen function, Obstet Gynecol 57:69, 1981.
252. **Korth-Schutz S, Levine LS, New MI**, Dehydroepiandrosterone sulfate (DS) levels, a rapid test for abnormal adrenal androgen secretion, J Clin Endocrinol Metabol 42:1005, 1976.
253. **Fehér T, Poteczin E, Bodrogi L**, Relationship between serum dehydroepiandrosterone sulphate and urinary 17-ketosteroid values, Exp Clin Endocrinol Diabetes 85:209, 2009.
254. **Abraham GE, Chakmakjian ZH**, Serum steroid levels during the menstrual cycle in a bilaterally adrenalectomized woman, J Clin Endocrinol Metabol 37:581, 1973.
255. **Abraham GE**, Ovarian and adrenal contribution to peripheral androgens during the menstrual cycle, J Clin Endocrinol Metabol 39:340, 1974.
256. **Nieschlag E, Loriaux DL, Ruder HJ, Zucker IR, Kirschner MA, Lipsett MB**, The secretion of dehydroepiandrosterone and dehydroepiandrosterone sulphate in man, J Endocrinol 57:123, 1973.
257. **Rosenfeld RS, Rosenberg BJ, Fukushima DK, Hellman L**, 24-hour secretory pattern of dehydroisoandrosterone and dehydroisoandrosterone sulfate, J Clin Endocrinol Metabol 40:850, 1975.
258. **Mikulecky M, Kreze A, Putz Z, Moravcik M**, Daily variation of serum cortisol, 17-hydroxyprogesterone and five androgens in healthy women, Braz J Med Biol Res 28:485, 1995.
259. **Zerah M, Rhéaume E, Mani P**, et al., No evidence of mutations in the genes for type I and type II 3 beta-hydroxysteroid dehydrogenase (3 beta HSD) in nonclassical 3 beta HSD deficiency, J Clin Endocrinol Metabol 79:1811, 1994.
260. **Carbunaru G, Prasad P, Scoccia B**, et al., The hormonal phenotype of nonclassic 3 $\beta$ -hydroxysteroid dehydrogenase (HSD3B) deficiency in hyperandrogenic females is associated with insulin-resistant polycystic ovary syndrome and is not a variant of inherited HSD3B2 deficiency, J Clin Endocrinol Metabol 89:783, 2004.



261. **Kamilaris TC**, Testosterone-secreting adrenal adenoma in a peripubertal girl, *JAMA* 258:2558, 1987.
262. **Rosenfield RL**, Polycystic ovary syndrome and insulin-resistant hyperinsulinemia, *J Am Acad Dermatol* 45:S95, 2001.
263. **Deplewski D**, Role of hormones in pilosebaceous unit development, *Endocr Rev* 21:363, 2000.
264. **Wijeyaratne CN, Balen AH, Barth JH, Belchetz PE**, Clinical manifestations and insulin resistance (IR) in polycystic ovary syndrome (PCOS) among South Asians and Caucasians: is there a difference? *Clin Endocrinol (Oxf)* 57:343, 2002.
265. **Falsetti L, Gambera A, Andrico S, Sartori E**, Acne and hirsutism in polycystic ovary syndrome: clinical, endocrine-metabolic and ultrasonographic differences, *Gynecol Endocrinol* 16:275, 2002.
266. **Schmidt TH, Khanijow K, Cedars MI, et al.**, Cutaneous findings and systemic associations in women with polycystic ovary syndrome, *JAMA Dermatol* 152:391, 2016.
267. **Williamson K, Gunn AJ, Johnson N, Milsom SR**, The impact of ethnicity on the presentation of polycystic ovarian syndrome, *Aust N Z J Obstet Gynaecol* 41:202, 2001.
268. **Rea JN, Newhouse ML, Halil T**, Skin disease in Lambeth. A community study of prevalence and use of medical care, *J Epidemiol Commun Health* 30:107, 1976.
269. **Johnson MT, Roberts J**, Skin conditions and related need for medical care among persons 1-74 years. United States, 1971-1974, *Vital Health Stat* 11 (212):1, 1978.
270. **Cunliffe WJ, Gould DJ**, Prevalence of facial acne vulgaris in late adolescence and in adults, *BMJ* 1:1109, 1979.
271. **Dalgard F, Svensson A, Holm JO, Sundby J**, Self-reported skin morbidity in Oslo. Associations with sociodemographic factors among adults in a cross-sectional study, *Br J Dermatol* 151:452, 2004.
272. **Galobardes B, Davey Smith G, Jeffreys M, McCarron P**, Has acne increased? Prevalence of acne history among university students between 1948 and 1968. The Glasgow Alumni Cohort Study, *Br J Dermatol* 152:824, 2005.
273. **Zouboulis CC, Degitz K**, Androgen action on human skin—from basic research to clinical significance, *Exp Dermatol* 13(Suppl 4):5, 2004.
274. **Uysal G, Sahin Y, Unluhizarci K, et al.**, Is acne a sign of androgen excess disorder or not? *Eur J Obstet Gynecol Reprod Biol* 211:21, 2017.
275. **Timpatanapong P, Rojanasakul A**, Hormonal profiles and prevalence of polycystic ovary syndrome in women with acne, *J Dermatol* 24:223, 1997.
276. **van der Meeren HL, van der Schaar WW, van den Hurk CM**, The psychological impact of severe acne, *Cutis* 36:84, 1985.
277. **Demircay Z, Seckin D, Senol A, Demir F**, Patient's perspective: an important issue not to be overlooked in assessing acne severity, *Eur J Dermatol* 18:181, 2008.
278. **Motley RJ, Finlay AY**, How much disability is caused by acne? *Clin Exp Dermatol* 14:194, 1989.
279. **Witkowski JA, Simons HM**, Objective evaluation of demethylchlortetracycline hydrochloride in the treatment of acne, *JAMA* 196:397, 1966.
280. **Tan JK**, Current measures for the evaluation of acne severity, *Expert Rev Dermatol* 3:595, 2014.
281. **Conway GS, Honour JW, Jacobs HS**, Heterogeneity of the polycystic ovary syndrome: clinical, endocrine and ultrasound features in 556 patients, *Clin Endocrinol (Oxf)* 30:459, 1989.
282. **Cela E, Robertson C, Rush K, et al.**, Prevalence of polycystic ovaries in women with androgenic alopecia, *Eur J Endocrinol* 149:439, 2003.
283. **Futterweit W, Dunaif A, Yeh H-C, Kingsley P**, The prevalence of hyperandrogenism in 109 consecutive female patients with diffuse alopecia, *J Am Acad Dermatol* 19:831, 1988.
284. **Ludwig E**, Classification of the types of androgenetic alopecia (common baldness) occurring in the female sex, *Br J Dermatol* 97:247, 1977.
285. **Goodman NF, Cobin RH, Futterweit W, Glueck JS, Legro RS, Carmina E**, American Association of Clinical Endocrinologists, American College of Endocrinology, and androgen excess and PCOS society disease state clinical review: guide to the best practices in the evaluation and treatment of polycystic ovary syndrome—part 1, *Endocr Pract* 21:1291, 2015.

286. **Quinn M, Shinkai K, Pasch L, Kuzmich L, Cedars M, Huddleston H**, Prevalence of androgenic alopecia in patients with polycystic ovary syndrome and characterization of associated clinical and biochemical features, *Fertil Steril* 101:1129, 2014.
287. **Deborah E Ikheba JW, Naqvi N, Pal L**, Predictors of scalp hair thinning in women with polycystic ovary syndrome, *US Endocrinol* 12:26, 2016.
288. **O'Driscoll JB, Mamtora H, Higginson J, Pollock A, Kane J, Anderson DC**, A prospective study of the prevalence of clear-cut endocrine disorders and polycystic ovaries in 350 patients presenting with hirsutism or androgenic alopecia, *Clin Endocrinol (Oxf)* 41:231, 1994.
289. **Malcolm CE, Cumming DC**, Does anovulation exist in eumenorrheic women? *Obstet Gynecol* 102:317, 2003.
290. **Petsos P, Mamtora H, Ratcliffe WA, Anderson DC**, Inadequate luteal phase usually indicates ovulatory dysfunction: observations from serial hormone and ultrasound monitoring of 115 cycles, *Gynecol Endocrinol* 1:37, 1987.
291. **Chang WY, Knochenhauer ES, Bartolucci AA, Azziz R**, Phenotypic spectrum of polycystic ovary syndrome: clinical and biochemical characterization of the three major clinical subgroups, *Fertil Steril* 83:1717, 2005.
292. **Carmina E, Lobo RA**, Do hyperandrogenic women with normal menses have polycystic ovary syndrome? *Fertil Steril* 71:319, 1999.
293. **Carmina E**, Prevalence of idiopathic hirsutism, *Eur J Endocrinol* 139:421, 1998.
294. **Azziz R, Waggoner WT, Ochoa T, Knochenhauer ES, Boots LR**, Idiopathic hirsutism: an uncommon cause of hirsutism in Alabama, *Fertil Steril* 70:274, 1998.
295. **Adams JM, Taylor AE, Crowley WF Jr, Hall JE**, Polycystic ovarian morphology with regular ovulatory cycles: insights into the pathophysiology of polycystic ovarian syndrome, *J Clin Endocrinol Metabol* 89:4343, 2004.
296. **Koivunen R, Laatikainen T, Tomás C, Huhtaniemi I, Tapanainen J, Martikainen H**, The prevalence of polycystic ovaries in healthy women, *Acta Obstet Gynecol Scand* 78:137, 1999.
297. **Norman RJ, Hague WM, Masters SC, Wang XJ**, Endocrinology: subjects with polycystic ovaries without hyperandrogenaemia exhibit similar disturbances in insulin and lipid profiles as those with polycystic ovary syndrome, *Hum Reprod* 10:2258, 1995.
298. **Chang PL, Lindheim SR, Lowre C**, et al., Normal ovulatory women with polycystic ovaries have hyperandrogenic pituitary-ovarian responses to gonadotropin-releasing hormone-agonist testing, *J Clin Endocrinol Metabol* 85:995, 2000.
299. **Carmina E, Wong L, Chang L, Paulson RJ, Sauer MV, Stanczyk FZ, Lobo RA**, Endocrine abnormalities in ovulatory women with polycystic ovaries on ultrasound, *Hum Reprod* 12:905, 1997.
300. **Pache TD, Wladimiroff JW, Hop WC, Fauser BC**, How to discriminate between normal and polycystic ovaries: transvaginal US study, *Radiology* 183:421, 1992.
301. **van Santbrink EJ, Hop WC, Fauser BC**, Classification of normogonadotropic infertility: polycystic ovaries diagnosed by ultrasound versus endocrine characteristics of polycystic ovary syndrome, *Fertil Steril* 67:452, 1997.
302. **Jonard S**, Ultrasound examination of polycystic ovaries: is it worth counting the follicles? *Hum Reprod* 18:598, 2003.
303. **Adams J, Polson DW, Franks S**, Prevalence of polycystic ovaries in women with anovulation and idiopathic hirsutism, *BMJ* 293:355, 1986.
304. **Legro R, Myers E, Barnhart H**, et al., The pregnancy in polycystic ovary syndrome study: baseline characteristics of the randomized cohort including racial effects, *Fertil Steril* 86:914, 2006.
305. **Hahn S, Tan S, Elsenbruch S, Quadbeck B, Herrmann BL, Mann K, Janssen OE**, Clinical and biochemical characterization of women with polycystic ovary syndrome in North Rhine-Westphalia, *Horm Metab Res* 37:438, 2005.
306. **Amer SA, Li TC, Bygrave C, Sprigg A, Saravelos H, Cooke ID**, An evaluation of the inter-observer and intra-observer variability of the ultrasound diagnosis of polycystic ovaries, *Hum Reprod* 17:1616, 2002.

307. **Alborzi S, Khodae R, Parsanejad ME**, Ovarian size and response to laparoscopic ovarian electrocauterization in polycystic ovarian disease, *Int J Gynecol Obstet* 74:269, 2001.
308. **Khoury MY, Baracat EC, Pardini DP, Haidar MA, da Motta EL, de Lima GR**, Polycystic ovary syndrome: clinical and laboratory evaluation, *Sao Paulo Med J* 114:1222, 1996.
309. **Falsetti L, Eleftheriou G**, Hyperinsulinemia in the polycystic ovary syndrome: a clinical, endocrine and echographic study in 240 patients, *Gynecol Endocrinol* 10:319, 1996.
310. **Polson DW, Wadsworth J, Adams J, Franks S**, Polycystic ovaries—a common finding in normal women, *Lancet* 331:870, 1988.
311. **Clayton RN, Ogden V, Hodgkinson J, Worswick L, Rodin DA, Dyer S, Meade TW**, How common are polycystic ovaries in normal women and what is their significance for the fertility of the population? *Clin Endocrinol (Oxf)* 37:127, 1992.
312. **Farquhar CM, Birdsall M, Manning P, Mitchell JM, France JT**, The prevalence of polycystic ovaries on ultrasound scanning in a population of randomly selected women, *Aust N Z J Obstet Gynaecol* 34:67, 1994.
313. **Lowe P, Kovacs G, Howlett D**, Incidence of polycystic ovaries and polycystic ovary syndrome amongst women in Melbourne, Australia, *Aust N Z J Obstet Gynaecol* 45:17, 2005.
314. **Futterweit W, Yeh HC, Mechanick JI**, Ultrasonographic study of ovaries of 19 women with weight loss-related hypothalamic oligo-amenorrhea, *Biomed Pharmacother* 42:279, 1988.
315. **Ardaens Y, Robert Y, Lemaitre L, Fossati P, Dewailly D**, Polycystic ovarian disease: contribution of vaginal endosonography and reassessment of ultrasonic diagnosis, *Fertil Steril* 55:1062, 1991.
316. **Broekmans FJ, Knauff EAH, Valkenburg O, Laven JS, Eijkemans MJ, Fauser B**, PCOS according to the Rotterdam consensus criteria: change in prevalence among WHO-II anovulation and association with metabolic factors, *BJOG* 113:1210, 2006.
317. **Hassan MAM, Killick SR**, Ultrasound diagnosis of polycystic ovaries in women who have no symptoms of polycystic ovary syndrome is not associated with subfecundity or subfertility, *Fertil Steril* 80:966, 2003.
318. **Wong IL, Morris RS, Lobo RA, Paulson RJ, Sauer MV**, Endocrinology: isolated polycystic morphology in ovum donors predicts response to ovarian stimulation, *Hum Reprod* 10:524, 1995.
319. **Joseph-Horne R, Mason H, Batty S, White D, Hillier S, Urquhart M, Franks S**, Luteal phase progesterone excretion in ovulatory women with polycystic ovaries, *Hum Reprod* 17:1459, 2002.
320. **Morales AJ, Laughlin GA, Bützow T, Maheshwari H, Baumann G, Yen SS**, Insulin, somatotrophic, and luteinizing hormone axes in lean and obese women with polycystic ovary syndrome: common and distinct features, *J Clin Endocrinol Metab* 81:2854, 1996.
321. **Manieri C, Pastorino R, Marolda AR**, et al., Gonadotropin evaluation in the diagnosis of polycystic ovary syndrome using either a monoclonal or a polyclonal antibody radioimmunoassay, *J Endocrinol Invest* 15:219, 1992.
322. **Homburg R**, What is polycystic ovarian syndrome? A proposal for a consensus on the definition and diagnosis of polycystic ovarian syndrome, *Hum Reprod* 17:2495, 2002.
323. **Dunaif A**, Beta-cell dysfunction independent of obesity and glucose intolerance in the polycystic ovary syndrome, *J Clin Endocrinol Metab* 81:942, 1996.
324. **Ehrmann DA, Sturis J, Byrne MM, Karrison T, Rosenfield RL, Polonsky KS**, Insulin secretory defects in polycystic ovary syndrome. Relationship to insulin sensitivity and family history of non-insulin-dependent diabetes mellitus, *J Clin Invest* 96:520, 1995.
325. **Ehrmann DA, Breda E, Corcoran MC**, et al., Impaired  $\beta$ -cell compensation to dexamethasone-induced hyperglycemia in women with polycystic ovary syndrome, *Am J Physiol Endocrinol Metab* 287:E241, 2004.
326. **Ehrmann DA, Kasza K, Azziz R, Legro RS, Ghazzi MN**, Effects of race and family history of type 2 diabetes on metabolic status of women with polycystic ovary syndrome, *J Clin Endocrinol Metab* 90:66, 2005.
327. **McAuley KA, Williams SM, Mann JI**, et al., Diagnosing insulin resistance in the general population, *Diabetes Care* 24:460, 2001.
328. **Ferrannini E, Mari A**, How to measure insulin sensitivity, *J Hypertens* 16:895, 1998.
329. **Laakso M**, How good a marker is insulin level for insulin resistance? *Am J Epidemiol* 137:959, 1993.
330. **Matthews DR, Hosker JP, Rudenski AS, Naylor BA, Treacher DF, Turner RC**, Homeostasis model

assessment: insulin resistance and beta-cell function from fasting plasma glucose and insulin concentrations in man, *Diabetologia* 28:412, 1985.

331. **Wallace TM, Matthews DR**, The assessment of insulin resistance in man, *Diabet Med* 19:527, 2002.
332. **Bonora E, Targher G, Alberiche M**, et al., Homeostasis model assessment closely mirrors the glucose clamp technique in the assessment of insulin sensitivity: studies in subjects with various degrees of glucose tolerance and insulin sensitivity, *Diabetes Care* 23:57, 2000.
333. **Hanson RL, Pratley RE, Bogardus C**, et al., Evaluation of simple indices of insulin sensitivity and insulin secretion for use in epidemiologic studies, *Am J Epidemiol* 151:190, 2000.
334. **Škrha J, Haas T, Šindelka G**, et al., Comparison of the insulin action parameters from hyperinsulinemic clamps with homeostasis model assessment and QUICKI indexes in subjects with different endocrine disorders, *J Clin Endocrinol Metabol* 89:135, 2004.
335. **Deugarte C, Bartolucci A, Azziz R**, Prevalence of insulin resistance in the polycystic ovary syndrome using the homeostasis model assessment, *Fertil Steril* 83:1454, 2005.
336. **Katz A, Nambi SS, Mather K, Baron AD, Follmann DA, Sullivan G, Quon MJ**, Quantitative insulin sensitivity check index: a simple, accurate method for assessing insulin sensitivity in humans, *J Clin Endocrinol Metabol* 85:2402, 2000.
337. **Carmina E, Lobo RA**, Use of fasting blood to assess the prevalence of insulin resistance in women with polycystic ovary syndrome, *Fertil Steril* 82:661, 2004.
338. **Legro RS, Arslanian SA, Ehrmann DA**, et al., Diagnosis and treatment of polycystic ovary syndrome: an Endocrine Society clinical practice guideline, *J Clin Endocrinol Metab* 98:4565, 2013.
339. **Cobin R, Futterweit W, Nestler J**, et al., American Association of Clinical Endocrinologists position statement on metabolic and cardiovascular consequences of polycystic ovary syndrome, *Endocr Pract* 11:125, 2005.
340. **Salley KES, Wickham EP, Cheang KI, Essah PA, Karjane NW, Nestler JE**, Position statement: glucose intolerance in polycystic ovary syndrome—a position statement of the androgen excess society, *J Clin Endocrinol Metabol* 92:4546, 2007.
341. **Ibáñez L, Potau N, Georgopoulos N, Prat N, Gussinyé M, Carrascosa A**, Growth hormone, insulin-like growth factor-I axis, and insulin secretion in hyperandrogenic adolescents, *Fertil Steril* 64:1113, 1995.
342. **Ibanez L**, Anovulation after precocious pubarche: early markers and time course in adolescence, *J Clin Endocrinol Metab* 84:2691, 1999.
343. **Ibanez L**, Sensitization to insulin in adolescent girls to normalize hirsutism, hyperandrogenism, oligomenorrhea, dyslipidemia, and hyperinsulinism after precocious pubarche, *J Clin Endocrinol Metab* 85:3526, 2000.
344. **Ibáñez L, Valls C, Potau N, Marcos MV, de Zegher F**, Polycystic ovary syndrome after precocious pubarche: ontogeny of the low-birthweight effect, *Clin Endocrinol (Oxf)* 55:667, 2001.
345. **Ibanez L, Valls C, Ferrer A, Marcos MV, Rodriguez-Hierro F, de Zegher F**, Sensitization to insulin induces ovulation in nonobese adolescents with anovulatory hyperandrogenism, *J Clin Endocrinol Metabol* 86:3595, 2001.
346. **Ibanez L, De Zegher F**, Flutamide-metformin plus an oral contraceptive (OC) for young women with polycystic ovary syndrome: switch from third- to fourth-generation OC reduces body adiposity, *Hum Reprod* 19:1725, 2004.
347. **Legro RS, Kunselman AR, Dunaif A**, Prevalence and predictors of dyslipidemia in women with polycystic ovary syndrome, *Am J Med* 111:607, 2001.
348. **Anagnostis P, Tarlatzis BC, Kauffman RP**, Polycystic ovarian syndrome (PCOS): long-term metabolic consequences, *Metabolism* 86:33, 2018.
349. **Fauser BC, Tarlatzis BC, Rebar RW**, et al., Consensus on women's health aspects of polycystic ovary syndrome (PCOS): the Amsterdam ESHRE/ASRM-Sponsored 3rd PCOS Consensus Workshop Group, *Fertil Steril* 97:28.e25, 2012.
350. **Graf MJ, Richards CJ, Brown V, Meissner L, Dunaif A**, The independent effects of hyperandrogenaemia, hyperinsulinaemia, and obesity on lipid and lipoprotein profiles in women, *Clin Endocrinol (Oxf)* 33:119, 1990.
351. **Talbott E, Clerici A, Berga SL**, et al., Adverse lipid and coronary heart disease risk profiles in young women

with polycystic ovary syndrome: results of a case-control study, *J Clin Epidemiol* 51:415, 1998.

352. **Legro RS, Azziz R, Ehrmann D, Fereshetian AG, O'Keefe M, Ghazzi MN**, Minimal response of circulating lipids in women with polycystic ovary syndrome to improvement in insulin sensitivity with troglitazone, *J Clin Endocrinol Metabol* 88:5137, 2003.
353. **Valkenburg O, Steegers-Theunissen RP, Smedts HP, Dallinga-Thie GM, Fauser BC, Westerveld EH, Laven JS**, A more atherogenic serum lipoprotein profile is present in women with polycystic ovary syndrome: a case-control study, *J Clin Endocrinol Metabol* 93:470, 2008.
354. **Wild RA, Painter PC, Coulson PB, Carruth KB, Ranney GB**, Lipoprotein lipid concentrations and cardiovascular risk in women with polycystic ovary syndrome, *J Clin Endocrinol Metabol* 61:946, 1985.
355. **Robinson S, Henderson AD, Gelding SV, et al.**, Dyslipidaemia is associated with insulin resistance in women with polycystic ovaries, *Clin Endocrinol (Oxf)* 44:277, 1996.
356. **Recabarren SE, Smith R, Rios R, et al.**, Metabolic profile in sons of women with polycystic ovary syndrome, *J Clin Endocrinol Metabol* 93:1820, 2008.
357. **Sam S, Legro RS, Bentley-Lewis R, Dunaif A**, Dyslipidemia and metabolic syndrome in the sisters of women with polycystic ovary syndrome, *J Clin Endocrinol Metabol* 90:4797, 2005.
358. **Escobar-Morreale HF, Luque-Ramirez M, Gonzalez F**, Circulating inflammatory markers in polycystic ovary syndrome: a systematic review and metaanalysis, *Fertil Steril* 95:1048.e1, 2011.
359. **Deligeoroglou E, Vrachnis N, Athanasopoulos N, et al.**, Mediators of chronic inflammation in polycystic ovarian syndrome, *Gynecol Endocrinol* 28:974, 2012.
360. **Coulam CB, Annegers JF, Kranz JS**, Chronic anovulation syndrome and associated neoplasia, *Obstet Gynecol* 61:403, 1983.
361. **Ron E, Lunenfeld B, Menczer J, Blumstein T, Katz L, Oelsner G, Serr D**, Cancer incidence in a cohort of infertile women, *Am J Epidemiol* 125:780, 1987.
362. **Escobedo LG, Lee NC, Peterson HB, Wingo PA**, Infertility-associated endometrial cancer risk may be limited to specific subgroups of infertile women, *Obstet Gynecol* 77:124, 1991.
363. **Wild S, Pierpoint T, Jacobs H, McKeigue P**, Long-term consequences of polycystic ovary syndrome: results of a 31 year follow-up study, *Hum Fertil* 3:101, 2000.
364. **Hardiman P, Pillay OC, Atiomo W**, Polycystic ovary syndrome and endometrial carcinoma, *Lancet* 361:1810, 2003.
365. **Shafiee MN, Chapman C, Barrett D, Abu J, Atiomo W**, Reviewing the molecular mechanisms which increase endometrial cancer (EC) risk in women with polycystic ovarian syndrome (PCOS): time for paradigm shift? *Gynecol Oncol* 131:489, 2013.
366. **Farhi DC, Nosanchuk J, Silverberg SG**, Endometrial adenocarcinoma in women under 25 years of age, *Obstet Gynecol* 68:741, 1986.
367. **Dockerty MB, Lovelady SB, Foust GT Jr**, Carcinoma of the corpus uteri in young women, *Am J Obstet Gynecol* 61:966, 1951.
368. **Gitsch G, Hanzal E, Jensen D, Hacker NF**, Endometrial cancer in premenopausal women 45 years and younger, *Obstet Gynecol* 85:504, 1995.
369. **Barry JA, Azizia MM, Hardiman PJ**, Risk of endometrial, ovarian and breast cancer in women with polycystic ovary syndrome: a systematic review and meta-analysis, *Hum Reprod Update* 20:748, 2014.
370. **Moran C, Tapia MC, Hernandez E, Vazquez G, Garcia-Hernandez E, Bermudez JA**, Etiological review of hirsutism in 250 patients, *Arch Med Res* 25:311, 1994.
371. **Redmond GP**, Thyroid dysfunction and women's reproductive health, *Thyroid* 14:5, 2004.
372. **Lazarus JH**, Thyroid disorders associated with pregnancy, *Treat Endocrinol* 4:31, 2005.
373. **Pop VJ, Brouwers EP, Vader HL, Vulsma T, van Baar AL, de Vijlder JJ**, Maternal hypothyroxinaemia during early pregnancy and subsequent child development: a 3-year follow-up study, *Clin Endocrinol (Oxf)* 59:282, 2003.
374. **Haddow JE, Palomaki GE, Allan WC, et al.**, Maternal thyroid deficiency during pregnancy and subsequent neuropsychological development of the child, *N Engl J Med* 341:549, 1999.
375. **Krassas GE, Pontikides N, Kaltsas T, Papadopoulou P, Batrinos M**, Menstrual disturbances in

thyrotoxicosis, *Clin Endocrinol (Oxf)* 40:641, 1994.

376. **Krassas GE, Pontikides N, Kaltsas T, et al.**, Disturbances of menstruation in hypothyroidism disturbances of menstruation in hypothyroidism, *Clin Endocrinol (Oxf)* 50:655, 1999.
377. **Schiebinger RJ, Chrousos GP, Cutler GB Jr, Loriaux DL**, The effect of serum prolactin on plasma adrenal androgens and the production and metabolic clearance rate of dehydroepiandrosterone sulfate in normal and hyperprolactinemic subjects, *J Clin Endocrinol Metabol* 62:202, 1986.
378. **Higuchi K, Nawata H, Maki T, Higashizima M, Kato K-I, Ibayashi H**, Prolactin has a direct effect on adrenal androgen secretion, *J Clin Endocrinol Metabol* 59:714, 1984.
379. **Glintborg D, Henriksen JE, Andersen M, Hagen C, Hangaard J, Rasmussen PE, Schousboe K, Hermann AP**, Prevalence of endocrine diseases and abnormal glucose tolerance tests in 340 caucasian premenopausal women with hirsutism as the referral diagnosis, *Fertil Steril* 82:1570, 2004.
380. **Derksen J, Nagesser SK, Meinders AE, Haak HR, van de Velde C**, Identification of virilizing adrenal tumors in hirsute women, *N Engl J Med* 331:968, 1994.
381. **Barbieri RL**, Hyperandrogenic disorders, *Clin Obstet Gynecol* 33:640, 1990.
382. **Zargar AH, Wani AI, Masoodi SR, Laway BA, Bashir MI, Salahuddin M**, Epidemiologic and etiologic aspects of hirsutism in Kashmiri women in the Indian subcontinent, *Fertil Steril* 77:674, 2002.
383. **Balen AH, Conway GS, Kaltsas G, Techatrasak K, Manning PJ, West C, Jacobs HS**, Andrology: polycystic ovary syndrome: the spectrum of the disorder in 1741 patients, *Hum Reprod* 10:2107, 1995.
384. **Huerta R, Dewailly D, Decanter C, Knochenhauer ES, Boots LR, Azziz R**,  $11\beta$ -hydroxyandrostenedione and  $\delta 5$ -androstenediol as markers of adrenal androgen production in patients with 21-hydroxylase-deficient nonclassic adrenal hyperplasia, *Fertil Steril* 72:996, 1999.
385. **White PC, New MI, Dupont B**, Congenital adrenal hyperplasia, *N Engl J Med* 316:1519, 1987.
386. **White PC, New MI, Dupont B**, Congenital adrenal hyperplasia, *N Engl J Med* 316:1580, 1987.
387. **New MI**, Female pseudohermaphroditism, *Semin Perinatol* 16:299, 1992.
388. **Moran C, Azziz R**, 21-hydroxylase-deficient nonclassic adrenal hyperplasia: the great pretender, *Semin Reprod Med* 21:295, 2003.
389. **White PC**, Congenital adrenal hyperplasia due to 21-hydroxylase deficiency, *Endocr Rev* 21:245, 2000.
390. **Therrell BL, Berenbaum SA, Manter-Kapanke V, et al.**, Results of screening 1.9 million texas newborns for 21-hydroxylase-deficient congenital adrenal hyperplasia, *Pediatrics* 101:583, 1998.
391. **Azziz R, Zacur HA**, 21-hydroxylase deficiency in female hyperandrogenism: screening and diagnosis, *J Clin Endocrinol Metabol* 69:577, 1989.
392. **Azziz R, Hincapie LA, Knochenhauer ES, Dewailly D, Fox L, Boots LR**, Screening for 21-hydroxylase-deficient nonclassic adrenal hyperplasia among hyperandrogenic women: a prospective study, *Fertil Steril* 72:915, 1999.
393. **Moran C, Azziz R, Carmina E, et al.**, 21-hydroxylase-deficient nonclassic adrenal hyperplasia is a progressive disorder: a multicenter study, *Am J Obstet Gynecol* 183:1468, 2000.
394. **New MI, Lorenzen F, Lerner AJ, Kohn B, Oberfield SE, Pollack MS, Dupont B, Stoner E, Levy DJ, Pang S, Levine LS**, Genotyping steroid 21-hydroxylase deficiency: hormonal reference data, *J Clin Endocrinol Metabol* 57:320, 1983.
395. **Azziz R, Dewailly D, Owerbach D**, Clinical review 56: nonclassic adrenal hyperplasia: current concepts, *J Clin Endocrinol Metabol* 78:810, 1994.
396. **Schweikert HU, Wilson JD**, Regulation of human hair growth by steroid hormones. I. Testosterone metabolism in isolated hairs, *J Clin Endocrinol Metab* 38:811, 1974.
397. **Unluhizarci K, Gokce C, Atmaca H, Bayram F, Kelestimur F**, A detailed investigation of hirsutism in a Turkish population: idiopathic hyperandrogenemia as a perplexing issue, *Exp Clin Endocrinol Diabetes* 112:504, 2004.
398. **Semple RK, Savage DB, Cochran EK, Gorden P, O'Rahilly S**, Genetic syndromes of severe insulin resistance, *Endocr Rev* 32:498, 2011.
399. **Barbieri RL, Ryan KJ**, Hyperandrogenism, insulin resistance, and acanthosis nigricans syndrome: a common endocrinopathy with distinct pathophysiologic features, *Am J Obstet Gynecol* 147:90, 1983.

400. **Vidal-Puig A, Moller D**, Inherited causes of androgen excess: classification, prevalence, clinical manifestations, and diagnosis, In: Azziz R, Nestler JE, Dewailly D, eds. *Androgen Excess Disorders in Women*, Lippincott-Raven, Philadelphia, 1997, p. 227.
401. **Geist SH, Gaines JA**, Diffuse luteinization of the ovaries associated with the masculinization syndrome, *Am J Obstet Gynecol* 43:975, 1942.
402. **Nagamani M, Van Dinh T, Kelder ME**, Hyperinsulinemia in hyperthecosis of the ovaries, *Am J Obstet Gynecol* 154:384, 1986.
403. **Moran LJ, Brinkworth G, Noakes M, Norman RJ**, Effects of lifestyle modification in polycystic ovarian syndrome, *Reprod Biomed Online* 12:569, 2006.
404. **Kiddy DS, Hamilton-Fairley D, Bush A, Short F, Anyaoku V, Reed MJ, Franks S**, Improvement in endocrine and ovarian function during dietary treatment of obese women with polycystic ovary syndrome, *Clin Endocrinol (Oxf)* 36:105, 1992.
405. **Pasquali R, Gambineri A, Biscotti D**, et al., Effect of long-term treatment with metformin added to hypocaloric diet on body composition, fat distribution, and androgen and insulin levels in abdominally obese women with and without the polycystic ovary syndrome, *J Clin Endocrinol Metabol* 85:2767, 2000.
406. **Crosignani PG, Colombo M, Vegetti W, Somigliana E, Gessati A, Ragni G**, Overweight and obese anovulatory patients with polycystic ovaries: parallel improvements in anthropometric indices, ovarian physiology and fertility rate induced by diet, *Hum Reprod* 18:1928, 2003.
407. **Moran LJ, Noakes M, Clifton PM, Tomlinson L, Norman RJ**, Dietary composition in restoring reproductive and metabolic physiology in overweight women with polycystic ovary syndrome, *J Clin Endocrinol Metabol* 88:812, 2003.
408. **Knowler WC, Barrett-Connor E, Fowler SE, Hamman RF, Lachin JM, Walker EA, Nathan DM**, Reduction in the incidence of type 2 diabetes with lifestyle intervention or metformin, *N Engl J Med* 346:393, 2002.
409. **Gokcel A, Gumurdulu Y, Karakose H, Melek Ertorer E, Tanaci N, BascilTutuncu N, Guvener N**, Evaluation of the safety and efficacy of sibutramine, orlistat and metformin in the treatment of obesity, *Diabetes Obes Metab* 4:49, 2002.
410. **Kay JP, Alemzadeh R, Langley G, D'Angelo L, Smith P, Holshouser S**, Beneficial effects of metformin in normoglycemic morbidly obese adolescents, *Metabolism* 50:1457, 2001.
411. **Freemark M, Bursey D**, The effects of metformin on body mass index and glucose tolerance in obese adolescents with fasting hyperinsulinemia and a family history of type 2 diabetes, *Pediatrics* 107:e55, 2001.
412. **Lord JM**, Metformin in polycystic ovary syndrome: systematic review and meta-analysis, *BMJ* 327:951, 2003.
413. **Sahin I, Serter R, Karakurt F**, et al., Metformin versus flutamide in the treatment of metabolic consequences of non-obese young women with polycystic ovary syndrome: a randomized prospective study, *Gynecol Endocrinol* 19:115, 2004.
414. **Tang T, Glanville J, Orsi N, Barth JH, Balen AH**, The use of metformin for women with PCOS undergoing IVF treatment, *Hum Reprod* 21:1416, 2006.
415. **Morin-Papunen LC VI, Koivunen RM, Ruokonen A, Martikainen HK, Tapanainen JS**, Endocrine and metabolic effects of metformin versus ethinyl estradiol-cyproterone acetate in obese women with polycystic ovary syndrome: a randomized study, *J Clin Endocrinol Metabol* 85:3161, 2000.
416. **Harborne L, Fleming R, Lyall H, Sattar N, Norman J**, Metformin or antiandrogen in the treatment of hirsutism in polycystic ovary syndrome, *J Clin Endocrinol Metabol* 88:4116, 2003.
417. **Harborne LR, Sattar N, Norman JE, Fleming R**, Metformin and weight loss in obese women with polycystic ovary syndrome: comparison of doses, *J Clin Endocrinol Metabol* 90:4593, 2005.
418. **Morin-Papunen L, Vauhkonen I, Koivunen R, Ruokonen A, Martikainen H, Tapanainen JS**, Metformin versus ethinyl estradiol-cyproterone acetate in the treatment of nonobese women with polycystic ovary syndrome: a randomized study, *J Clin Endocrinol Metabol* 88:148, 2003.
419. **Costello MF, Shrestha B, Eden J, Johnson NP, Sjoblom P**, Metformin versus oral contraceptive pill in polycystic ovary syndrome: a cochrane review, *Hum Reprod* 22:1200, 2007.
420. **Elter K, Imir G, Durmusoglu F**, Clinical, endocrine and metabolic effects of metformin added to ethinyl

estradiol-cyproterone acetate in non-obese women with polycystic ovarian syndrome: a randomized controlled study, *Hum Reprod* 17:1729, 2002.

421. **Tan S, Hahn S, Benson S, et al.**, Metformin improves polycystic ovary syndrome symptoms irrespective of pre-treatment insulin resistance, *Eur J Endocrinol* 157:669, 2007.
422. **Naderpoor N, Shorakae S, de Courten B, Misso ML, Moran LJ, Teede HJ**, Metformin and lifestyle modification in polycystic ovary syndrome: systematic review and meta-analysis, *Hum Reprod Update* 21:560, 2015.
423. **Nybacka A, Hellstrom PM, Hirschberg AL**, Increased fibre and reduced trans fatty acid intake are primary predictors of metabolic improvement in overweight polycystic ovary syndrome-substudy of randomized trial between diet, exercise and diet plus exercise for weight control, *Clin Endocrinol (Oxf)* 87:680, 2017.
424. **Hoeger KM**, Exercise therapy in polycystic ovary syndrome, *Semin Reprod Med* 26:93, 2008.
425. **Paraskevaidis E, Kalantaridou SN, Papadimitriou D, et al.**, Transvaginal uterine ultrasonography compared with endometrial biopsy for the detection of endometrial disease in perimenopausal women with uterine bleeding, *Anticancer Res* 22:1829, 2002.
426. **Cheung AP**, Ultrasound and menstrual history in predicting endometrial hyperplasia in polycystic ovary syndrome, *Obstet Gynecol* 98:325, 2001.
427. **Dueholm M, Jensen ML, Laursen H, Kracht P**, Can the endometrial thickness as measured by transvaginal sonography be used to exclude polyps or hyperplasia in pre-menopausal patients with abnormal uterine bleeding? *Acta Obstet Gynecol Scand* 80:645, 2001.
428. **Givens JR, Andersen RN, Wiser WL, Fish SA**, Dynamics of suppression and recovery of plasma FSH, LH, androstenedione and testosterone in polycystic ovarian disease using an oral contraceptive, *J Clin Endocrinol Metabol* 38:727, 1974.
429. **Givens JR, Andersen RN, Wiser WL, Umstot ES, Fish SA**, The effectiveness of two oral contraceptives in suppressing plasma androstenedione, testosterone, LH, and FSH, and in stimulating plasma testosterone-binding capacity in hirsute women, *Am J Obstet Gynecol* 124:333, 1976.
430. **Raj SG, Raj MH, Talbert LM, Sloan CS, Hicks B**, Normalization of testosterone levels using a low estrogen-containing oral contraceptive in women with polycystic ovary syndrome, *Obstet Gynecol* 60:15, 1982.
431. **Dewis P, Petsos P, Newman M, Anderson DC**, The treatment of hirsutism with a combination of desogestrel and ethinyl oestradiol, *Clin Endocrinol (Oxf)* 22:29, 1985.
432. **Granger LR, Roy S, Mishell DR**, Changes in unbound sex steroids and sex hormone binding globulin-binding capacity during oral and vaginal progestogen administration, *Am J Obstet Gynecol* 144:578, 1982.
433. **Cullberg G, Hamberger L, Mattsson L-Å, Mobacken H, Samsioe G**, Effects of a low-dose desogestrel-ethinylestradiol combination on hirsutism, androgens and sex hormone binding globulin in women with a polycystic ovary syndrome, *Acta Obstet Gynecol Scand* 64:195, 1985.
434. **Norman RJ, Dewailly D, Legro RS, Hickey TE**, Polycystic ovary syndrome, *Lancet* 370:685, 2007.
435. **Vrbikova J, Cibula D**, Combined oral contraceptives in the treatment of polycystic ovary syndrome, *Hum Reprod Update* 11:277, 2005.
436. **Kojima T, Lindheim SR, Duffy DM, Vijod MA, Stanczyk FZ, Lobo RA**, Insulin sensitivity is decreased in normal women by doses of ethinyl estradiol used in oral contraceptives, *Am J Obstet Gynecol* 169:1540, 1993.
437. **Korytkowski MT, Mokan M, Horwitz MJ, Berga SL**, Metabolic effects of oral contraceptives in women with polycystic ovary syndrome, *J Clin Endocrinol Metabol* 80:3327, 1995.
438. **Armstrong VL**, Insulin action and insulin secretion in polycystic ovary syndrome treated with ethinyl oestradiol/cyproterone acetate, *QJM* 94:31, 2001.
439. **Nader S**, The effect of a desogestrel-containing oral contraceptive on glucose tolerance and leptin concentrations in hyperandrogenic women, *J Clin Endocrinol Metab* 82:3074, 1997.
440. **Cibula D**, Insulin sensitivity in non-obese women with polycystic ovary syndrome during treatment with oral contraceptives containing low-androgenic progestin, *Hum Reprod* 17:76, 2002.
441. **Cibula D, Fanta M, Vrbikova J, et al.**, The effect of combination therapy with metformin and combined oral contraceptives (COC) versus COC alone on insulin sensitivity, hyperandrogenaemia, SHBG and lipids in PCOS patients, *Hum Reprod* 20:180, 2005.



442. **Escobar-Morreale HF, Lasunción MA, Sancho J**, Treatment of hirsutism with ethinyl estradiol–desogestrel contraceptive pills has beneficial effects on the lipid profile and improves insulin sensitivity, *Fertil Steril* 74:816, 2000.
443. **Cagnacci A, Paoletti AM, Renzi A**, et al., Glucose metabolism and insulin resistance in women with polycystic ovary syndrome during therapy with oral contraceptives containing cyproterone acetate or desogestrel, *J Clin Endocrinol Metabol* 88:3621, 2003.
444. **Mastorakos G, Koliopoulos C, Deligeoroglou E, Diamanti-Kandarakis E, Creatsas G**, Effects of two forms of combined oral contraceptives on carbohydrate metabolism in adolescents with polycystic ovary syndrome, *Fertil Steril* 85:420, 2006.
445. **Kjos SL, Shoupe D, Douyan S, Friedman RL, Bernstein GS, Mestman JH, Mishell DR Jr**, Effect of low-dose oral contraceptives on carbohydrate and lipid metabolism in women with recent gestational diabetes: Results of a controlled, randomized, prospective study, *Am J Obstet Gynecol* 163:1822, 1990.
446. **Kjos SL**, Contraception and the risk of type 2 diabetes mellitus in Latina women with prior gestational diabetes mellitus, *JAMA* 280:533, 1998.
447. **Garg SK**, Oral contraceptives and renal and retinal complications in young women with insulin-dependent diabetes mellitus, *JAMA* 271:1099, 1994.
448. **Petersen KR, Skouby SO, Sidelmann J, Mølsted-Petersen L, Jespersen J**, Effects of contraceptive steroids on cardiovascular risk factors in women with insulin-dependent diabetes mellitus, *Am J Obstet Gynecol* 171:400, 1994.
449. **Pasquali R, Gambineri A, Anconetani B**, et al., The natural history of the metabolic syndrome in young women with the polycystic ovary syndrome and the effect of long-term oestrogen-progestogen treatment, *Clin Endocrinol (Oxf)* 50:517, 1999.
450. **McLellan AR, Rentoul J, MacKie R, McInnes GT**, Lack of effect of spironolactone on hair shaft diameter in hirsute females, *Postgrad Med J* 65:459, 1989.
451. **Ibanez L, de Zegher F**, Low-dose flutamide-metformin therapy for hyperinsulinemic hyperandrogenism in non-obese adolescents and women, *Hum Reprod Update* 12:243, 2006.
452. **Moggetti P, Castello R, Negri C**, et al., Metformin effects on clinical features, endocrine and metabolic profiles, and insulin sensitivity in polycystic ovary syndrome: a randomized, double-blind, placebo-controlled 6-month trial, followed by open, long-term clinical evaluation, *J Clin Endocrinol Metabol* 85: 139, 2000.
453. **Swiglo BA, Cosma M, Flynn DN**, et al., Clinical review: antiandrogens for the treatment of hirsutism: a systematic review and metaanalyses of randomized controlled trials, *J Clin Endocrinol Metab* 93:1153, 2008.
454. **Wolf JE Jr, Shander D, Huber F**, et al., Randomized, double-blind clinical evaluation of the efficacy and safety of topical eflornithine HCl 13.9% cream in the treatment of women with facial hair, *Int J Dermatol* 46:94, 2007.
455. **Saleem F, Rizvi SW**, New therapeutic approaches in obesity and metabolic syndrome associated with polycystic ovary syndrome, *Cureus* 9:e1844, 2017.
456. **Pal L, Berry A, Coraluzzi L**, et al., Therapeutic implications of vitamin D and calcium in overweight women with polycystic ovary syndrome, *Gynecol Endocrinol* 28:965, 2012.
457. **Seyam E, Al Gelany S, Abd Al Ghaney A**, et al., Evaluation of prolonged use of statins on the clinical and biochemical abnormalities and ovulation dysfunction in single young women with polycystic ovary syndrome, *Gynecol Endocrinol* 2018 34(7):589.
458. **Legro RS**, Pregnancy considerations in women with polycystic ovary syndrome, *Clin Obstet Gynecol* 50:295, 2007.
459. **Legro RS, Kunselman AR, Brzyski RG**, et al., The pregnancy in polycystic ovary syndrome II (PPCOS II) trial: rationale and design of a double-blind randomized trial of clomiphene citrate and letrozole for the treatment of infertility in women with polycystic ovary syndrome, *Contemp Clin Trials* 33: 470, 2012.
460. **Legro RS, Brzyski RG, Diamond MP**, et al., Letrozole versus clomiphene for infertility in the polycystic ovary syndrome, *N Engl J Med* 371:119, 2014.
461. **Morley LC, Tang T, Yasmin E, Norman RJ, Balen AH**, Insulin-sensitising drugs (metformin, rosiglitazone, pioglitazone, D-chiro-inositol) for women with polycystic ovary syndrome, oligo amenorrhoea and subfertility,

Cochrane Database Syst Rev 11:CD003053, 2017.

462. **Practice Committee of the American Society for Reproductive Medicine, Practice Committee of the American Society for Reproductive Medicine**, Role of metformin for ovulation induction in infertile patients with polycystic ovary syndrome (PCOS): a guideline, *Fertil Steril* 108:426, 2017.
463. **Moll E, Bossuyt PM, Korevaar JC, Lambalk CB, van der Veen F**, Effect of clomifene citrate plus metformin and clomifene citrate plus placebo on induction of ovulation in women with newly diagnosed polycystic ovary syndrome: randomised double blind clinical trial, *BMJ* 332:1485, 2006.
464. **Legro RS, Barnhart HX, Schlaff WD, Carr BR, Diamond MP, Carson SA, Steinkampf MP, Coutifaris C, McGovern PG, Cataldo NA, Gosman GG, Nestler JE, Giudice LC, Leppert PC, Myers ER**, Clomiphene, metformin, or both for infertility in the polycystic ovary syndrome, *N Engl J Med* 356:551, 2007.
465. **Zain MM, Jamaluddin R, Ibrahim A, Norman RJ**, Comparison of clomiphene citrate, metformin, or the combination of both for first-line ovulation induction, achievement of pregnancy, and live birth in Asian women with polycystic ovary syndrome: a randomized controlled trial, *Fertil Steril* 91:514, 2009.
466. **Creanga AA, Bradley HM, McCormick C, Witkop CT**, Use of metformin in polycystic ovary syndrome, *Obstet Gynecol* 111:959, 2008.
467. **Vandermolen DT, Ratts VS, Evans WS, Stovall DW, Kauma SW, Nestler JE**, Metformin increases the ovulatory rate and pregnancy rate from clomiphene citrate in patients with polycystic ovary syndrome who are resistant to clomiphene citrate alone, *Fertil Steril* 75:310, 2001.
468. **Kocak M, Caliskan E, Simsir C, Haberal A**, Metformin therapy improves ovulatory rates, cervical scores, and pregnancy rates in clomiphene citrate-resistant women with polycystic ovary syndrome, *Fertil Steril* 77:101, 2002.
469. **Malkawi HY, Qublan HS**, The effect of metformin plus clomiphene citrate on ovulation and pregnancy rates in clomiphene-resistant women with polycystic ovary syndrome, *Saudi Med J* 23:663, 2002.
470. **Hwu YM, Lin SY, Huang WY, Lin MH, Lee RK**, Ultra-short metformin pretreatment for clomiphene citrate-resistant polycystic ovary syndrome, *Int J Gynecol Obstet* 90:39, 2005.
471. **Baillargeon J, Jakubowicz D, Iuorno M, Jakubowicz S, Nestler J**, Effects of metformin and rosiglitazone, alone and in combination, in nonobese women with polycystic ovary syndrome and normal indices of insulin sensitivity, *Fertil Steril* 82:893, 2004.
472. **Rouzi AA, Ardawi MSM**, A randomized controlled trial of the efficacy of rosiglitazone and clomiphene citrate versus metformin and clomiphene citrate in women with clomiphene citrate-resistant polycystic ovary syndrome, *Fertil Steril* 85:428, 2006.
473. **Gilbert C, Valois M, Koren G**, Pregnancy outcome after first-trimester exposure to metformin: a meta-analysis, *Fertil Steril* 86:658, 2006.
474. **Homburg R**, Pregnancy complications in PCOS, *Best Pract Res Clin Endocrinol Metab* 20:281, 2006.
475. **Palomba S, Falbo A, Orio F, et al.**, A randomized controlled trial evaluating metformin pre-treatment and co-administration in non-obese insulin-resistant women with polycystic ovary syndrome treated with controlled ovarian stimulation plus timed intercourse or intrauterine insemination, *Hum Reprod* 20:2879, 2005.
476. **Palomba S, Orio F Jr, Nardo LG, Falbo A, Russo T, Corea D, Doldo P, Lombardi G, Tolino A, Colao A, Zullo F**, Metformin administration versus laparoscopic ovarian diathermy in clomiphene citrate-resistant women with polycystic ovary syndrome: a prospective parallel randomized double-blind placebo-controlled trial, *J Clin Endocrinol Metabol* 89:4801, 2004.
477. **Glueck CJ**, Metformin during pregnancy reduces insulin, insulin resistance, insulin secretion, weight, testosterone and development of gestational diabetes: prospective longitudinal assessment of women with polycystic ovary syndrome from preconception throughout pregnancy, *Hum Reprod* 19:510, 2004.
478. **Mathur R, Alexander CJ, Yano J, Trivax B, Azziz R**, Use of metformin in polycystic ovary syndrome, *Am J Obstet Gynecol* 199:596, 2008.
479. **van Santbrink EJ, Fauser BC**, Ovulation induction in normogonadotropic anovulation (PCOS), *Best Pract Res Clin Endocrinol Metab* 20:261, 2006.
480. **López E, Joanne G, Daya S, et al.**, Ovulation induction in women with polycystic ovary syndrome: randomized trial of clomiphene citrate versus low-dose recombinant FSH as first line therapy, *Reprod Biomed*

Online 9:382, 2004.

481. **Christin-Maitre S**, A comparative randomized multicentric study comparing the step-up versus step-down protocol in polycystic ovary syndrome, *Hum Reprod* 18:1626, 2003.
482. **Mulders AG, Eijkemans MJ, Imani B, Fauser BC**, Prediction of chances for success or complications in gonadotrophin ovulation induction in normogonadotrophic anovulatory infertility, *Reprod Biomed Online* 7:170, 2003.
483. **Tummon I, Gavrilova-Jordan L, Allemand MC, Session D**, Polycystic ovaries and ovarian hyperstimulation syndrome: a systematic review, *Acta Obstet Gynecol Scand* 84:611, 2005.
484. **Navot D, Goldstein N, Mor-Josef S, Simon A, Relou A, Birkenfeld A**, Multiple pregnancies: risk factors and prognostic variables during induction of ovulation with human menopausal gonadotrophins, *Hum Reprod* 6:1152, 1991.
485. **Huang X, Wang P, Tal R, Lv F, Li Y, Zhang X**, A systematic review and meta-analysis of metformin among patients with polycystic ovary syndrome undergoing assisted reproductive technology procedures, *Int J Gynaecol Obstet* 131:111, 2015.
486. **Palomba S, Falbo A, La Sala GB**, Effects of metformin in women with polycystic ovary syndrome treated with gonadotrophins for in vitro fertilisation and intracytoplasmic sperm injection cycles: a systematic review and meta-analysis of randomised controlled trials, *BJOG* 120:267, 2013.
487. **Moll E, van der Veen F, van Wely M**, The role of metformin in polycystic ovary syndrome: a systematic review, *Hum Reprod Update* 13:527, 2007.
488. **Sortino MA, Salomone S, Carruba MO, Drago F**, Polycystic ovary syndrome: insights into the therapeutic approach with inositols, *Front Pharmacol* 8:341, 2017.
489. **Amer SA, Shamy TTE, James C, Yosef AH, Mohamed AA**, The impact of laparoscopic ovarian drilling on AMH and ovarian reserve: a meta-analysis, *Reproduction* 154(1):R13, 2017.
490. **Farquhar C, Lilford RJ, Marjoribanks J, Vandekerckhove P**, Laparoscopic “drilling” by diathermy or laser for ovulation induction in anovulatory polycystic ovary syndrome, *Cochrane Database Syst Rev* (3):CD001122, 2005.
491. **Farquhar C, Brown J, Marjoribanks J**, Laparoscopic drilling by diathermy or laser for ovulation induction in anovulatory polycystic ovary syndrome, *Cochrane Database Syst Rev* (6):CD001122, 2012.
492. **Lepine S, Jo J, Metwally M, Cheong YC**, Ovarian surgery for symptom relief in women with polycystic ovary syndrome, *Cochrane Database Syst Rev* 11:CD009526, 2017.
493. **Chu J, Gallos I, Tobias A, Tan B, Eapen A, Coomarasamy A**, Vitamin D and assisted reproductive treatment outcome: a systematic review and meta-analysis, *Hum Reprod* 33:65, 2018.
494. **Pal L, Zhang H, Williams J, Santoro NF, Diamond MP, Schlaff WD, Coutifaris C, Carson SA, Steinkampf MP, Carr BR, McGovern PG, Cataldo NA, Gosman GG, Nestler JE, Myers E, Legro RS**, Reproductive Medicine Network, *J Clin Endocrinol Metab* 101(8):3027–3035, 2016.
495. **Norman RJ, Masters L, Milner CR, Wang JX, Davies MJ**, Relative risk of conversion from normoglycaemia to impaired glucose tolerance or non-insulin dependent diabetes mellitus in polycystic ovarian syndrome, *Hum Reprod* 16:1995, 2001.
496. **Legro RS, Gnatuk CL, Kunselman AR, Dunaif A**, Changes in glucose tolerance over time in women with polycystic ovary syndrome: a controlled study, *J Clin Endocrinol Metab* 90:3236, 2005.
497. **Rubin KH, Glintborg D, Nybo M, Abrahamsen B, Andersen M**, Development and risk factors of type 2 diabetes in a nationwide population of women with polycystic ovary syndrome, *J Clin Endocrinol Metab* 102:3848, 2017.
498. **Moran LJ, Misso ML, Wild RA, Norman RJ**, Impaired glucose tolerance, type 2 diabetes and metabolic syndrome in polycystic ovary syndrome: a systematic review and meta-analysis, *Hum Reprod Update* 16:347, 2010.
499. **Luque-Ramirez M, Mendieta-Azcona C, Alvarez-Blasco F, Escobar-Morreale HF**, Androgen excess is associated with the increased carotid intima-media thickness observed in young women with polycystic ovary syndrome, *Hum Reprod* 22:3197, 2007.
500. **Dokras A**, Cardiovascular disease risk factors in polycystic ovary syndrome, *Semin Reprod Med* 26:39, 2008.

501. **Orio F, Palomba S, Colao A**, Cardiovascular risk in women with polycystic ovary syndrome, *Fertil Steril* 86:S20, 2006.
502. **Kelly CC, Lyall H, Petrie JR, Gould GW, Connell JM, Sattar N**, Low grade chronic inflammation in women with polycystic ovarian syndrome, *J Clin Endocrinol Metabol* 86:2453, 2001.
503. **Morin-Papunen L, Rautio K, Ruukonen A, Hedberg P, Puukka M, Tapanainen JS**, Metformin reduces serum C-reactive protein levels in women with polycystic ovary syndrome, *J Clin Endocrinol Metabol* 88:4649, 2003.
504. **Boulman N, Levy Y, Leiba R**, et al., Increased C-reactive protein levels in the polycystic ovary syndrome: a marker of cardiovascular disease, *J Clin Endocrinol Metabol* 89:2160, 2004.
505. **Ibáñez L, de Zegher F**, Flutamide-metformin plus ethinylestradiol-drospirenone for lipolysis and antiatherogenesis in young women with ovarian hyperandrogenism: the key role of metformin at the start and after more than one year of therapy, *J Clin Endocrinol Metabol* 90:39, 2005.
506. **Orio F, Palomba S, Cascella T**, et al., The increase of leukocytes as a new putative marker of low-grade chronic inflammation and early cardiovascular risk in polycystic ovary syndrome, *J Clin Endocrinol Metabol* 90:2, 2005.
507. **Tarkun I, Arslan BC, Canturk Z, Turemen E, Sahin T, Duman C**, Endothelial dysfunction in young women with polycystic ovary syndrome: relationship with insulin resistance and low-grade chronic inflammation, *J Clin Endocrinol Metabol* 89:5592, 2004.
508. **Sampson M, Kong C, Patel A, Unwin R, Jacobs HS**, Ambulatory blood pressure profiles and plasminogen activator inhibitor (PAI-1) activity in lean women with and without the polycystic ovary syndrome, *Clin Endocrinol (Oxf)* 45:623, 1996.
509. **Schneider DJ, Sobel BE**, Synergistic augmentation of expression of plasminogen activator inhibitor type-1 induced by insulin, very-low-density lipoproteins, and fatty acids. *Coron Artery Dis* 7:813, 1996.
510. **Lakhani K, Prelevic GM, Seifalian AM, Atiomo WU, Hardiman P**, Polycystic ovary syndrome, diabetes and cardiovascular disease: risks and risk factors, *J Obstet Gynaecol* 24:613, 2004.
511. **Essah PA, Nestler JE**, The metabolic syndrome in polycystic ovary syndrome, *J Endocrinol Invest* 29:270, 2006.
512. **Dahlgren E, Janson PO, Johansson S, Lapidus L, Odén A**, Polycystic ovary syndrome and risk for myocardial infarction: evaluated from a risk factor model based on a prospective population study of women, *Acta Obstet Gynecol Scand* 71:599, 1992.
513. **Lo JC, Feigenbaum SL, Yang J, Pressman AR, Selby JV, Go AS**, Epidemiology and adverse cardiovascular risk profile of diagnosed polycystic ovary syndrome, *J Clin Endocrinol Metabol* 91:1357, 2006.
514. **Reaven GM**, Banting lecture 1988. Role of insulin resistance in human disease, *Diabetes* 37:1595, 1988.
515. **Carmina E, Napoli N, Longo RA, Rini GB, Lobo RA**, Metabolic syndrome in polycystic ovary syndrome (PCOS): lower prevalence in southern Italy than in the USA and the influence of criteria for the diagnosis of PCOS, *Eur J Endocrinol* 154:141, 2005.
516. **Alberti KG, Zimmet PZ**, Definition, diagnosis and classification of diabetes mellitus and its complications. Part 1: diagnosis and classification of diabetes mellitus. Provisional report of a WHO Consultation, *Diabet Med* 15:539, 1998.
517. **Balkau B, Charles MA**, Comment on the provisional report from the WHO consultation, *Diabet Med* 16:442, 1999.
518. **Expert Panel on Detection, Evaluation, and Treatment of High Blood Cholesterol in Adults**, Treatment of high blood cholesterol in A. Executive summary of the third report of the national cholesterol education program (NCEP) expert panel on detection, evaluation, and treatment of high blood cholesterol in adults (adult treatment panel III), *JAMA* 285:2486, 2001.
519. **Alberti KG, Zimmet P, Shaw J; IDF Epidemiology Task Force Consensus Group**, The metabolic syndrome—a new worldwide definition, *Lancet* 366:1059, 2005.
520. **Cameron AJ, Shaw JE, Zimmet PZ**, The metabolic syndrome: prevalence in worldwide populations, *Endocrinol Metab Clin North Am* 33:351, 2004.
521. **Tan CE, Ma S, Wai D, Chew SK, Tai ES**, Can we apply the national cholesterol education program adult

- treatment panel definition of the metabolic syndrome to Asians? *Diabetes Care* 27:1182, 2004.
522. **Alberti KG, Eckel RH, Grundy SM, et al.**, Harmonizing the metabolic syndrome: a joint interim statement of the International Diabetes Federation Task Force on Epidemiology and Prevention; National Heart, Lung, and Blood Institute; American Heart Association; World Heart Federation; International Atherosclerosis Society; and International Association for the Study of Obesity, *Circulation* 120:1640, 2009.
  523. **Bailey CJ, Turner RC**, Metformin, *N Engl J Med* 334:574, 1996.
  524. **Morin-Papunen L**, Metformin therapy improves the menstrual pattern with minimal endocrine and metabolic effects in women with polycystic ovary syndrome, *Fertil Steril* 69:691, 1998.
  525. **Musi N, Hirshman MF, Nygren J, et al.**, Metformin increases AMP-activated protein kinase activity in skeletal muscle of subjects with type 2 diabetes, *Diabetes* 51:2074, 2002.
  526. **Zhou G, Myers R, Li Y, et al.**, Role of AMP-activated protein kinase in mechanism of metformin action, *J Clin Invest* 108:1167, 2001.
  527. **Zou M-H, Kirkpatrick SS, Davis BJ, et al.**, Activation of the AMP-activated protein kinase by the anti-diabetic drug metformin in vivo, *J Biol Chem* 279:43940, 2004.
  528. **Fryer LG, Parbu-Patel A, Carling D**, The anti-diabetic drugs rosiglitazone and metformin stimulate AMP-activated protein kinase through distinct signaling pathways, *J Biol Chem* 277:25226, 2002.
  529. **Hawley SA, Gadalla AE, Olsen GS, Hardie DG**, The antidiabetic drug metformin activates the AMP-activated protein kinase cascade via an adenine nucleotide-independent mechanism, *Diabetes* 51:2420, 2002.
  530. **Marcondes JAM, Yamashita SAY, Maciel GAR, Baracat EC, Halpern A**, Metformin in normal-weight hirsute women with polycystic ovary syndrome with normal insulin sensitivity, *Gynecol Endocrinol* 23:273, 2007.
  531. **Yilmaz M, Biri A, Karakoç A, et al.**, The effects of rosiglitazone and metformin on insulin resistance and serum androgen levels in obese and lean patients with polycystic ovary syndrome, *J Endocrinol Invest* 28:1003, 2005.
  532. **Ortega-González C, Luna S, Hernández L, et al.**, Responses of serum androgen and insulin resistance to metformin and pioglitazone in obese, insulin-resistant women with polycystic ovary syndrome, *J Clin Endocrinol Metabol* 90: 1360, 2005.
  533. **Palomba S, Falbo A, Russo T, Manguso F, Tolino A, Zullo F, De Feo P, Orio F Jr**, Insulin sensitivity after metformin suspension in normal-weight women with polycystic ovary syndrome, *J Clin Endocrinol Metabol* 92:3128, 2007.
  534. **Nawrocka J, Starczewski A**, Effects of metformin treatment in women with polycystic ovary syndrome depends on insulin resistance, *Gynecol Endocrinol* 23:231, 2007.
  535. **Tang T, Norman RJ, Balen AH, Lord JM**, Insulin-sensitising drugs (metformin, troglitazone, rosiglitazone, pioglitazone, D-chiro-inositol) for polycystic ovary syndrome, *Cochrane Database Syst Rev* (3):CD003053, 2003.
  536. **Wang J, Zhu L, Hu K, et al.**, Effects of metformin treatment on serum levels of C-reactive protein and interleukin-6 in women with polycystic ovary syndrome: a meta-analysis: a PRISMA-compliant article, *Medicine (Baltimore)* 96:e8183, 2017.
  537. **Salpeter SR, Buckley NS, Kahn JA, Salpeter EE**, Meta-analysis: metformin treatment in persons at risk for diabetes mellitus, *Am J Med* 121:149.e2, 2008.
  538. **Diamanti-Kandarakis E, Paterakis T, Alexandraki K, et al.**, Indices of low-grade chronic inflammation in polycystic ovary syndrome and the beneficial effect of metformin, *Hum Reprod* 21:1426, 2006.
  539. **Samy N, Hashim M, Sayed M, Said M**, Clinical significance of inflammatory markers in polycystic ovary syndrome: their relationship to insulin resistance and body mass index, *Dis Markers* 26:163, 2009.
  540. **Tarkun I, Cetinarslan B, Turemen E, Sahin T, Canturk Z, Komsuoglu B**, Effect of rosiglitazone on insulin resistance, C-reactive protein and endothelial function in non-obese young women with polycystic ovary syndrome, *Eur J Endocrinol* 153:115, 2005.
  541. **Topcu S, Tok D, Caliskan M, et al.**, Metformin therapy improves coronary microvascular function in patients with polycystic ovary syndrome and insulin resistance, *Clin Endocrinol (Oxf)* 65:75, 2006.
  542. **Agarwal N, Rice SP, Bolusani H, Luzio SD, Dunseath G, Ludgate M, Rees DA**, Metformin reduces arterial stiffness and improves endothelial function in young women with polycystic ovary syndrome: a

- randomized, placebo-controlled, crossover trial, *J Clin Endocrinol Metabol* 95:722, 2010.
543. **Teede HJ, Meyer C, Hutchison SK, Zoungas S, McGrath BP, Moran LJ**, Endothelial function and insulin resistance in polycystic ovary syndrome: the effects of medical therapy, *Fertil Steril* 93:184, 2010.
544. **Nestler JE**, Metformin for the treatment of the polycystic ovary syndrome, *N Engl J Med* 358:47, 2008.
545. **Azziz R, Ehrmann D, Legro RS**, et al., Troglitazone improves ovulation and hirsutism in the polycystic ovary syndrome: a multicenter, double blind, placebo-controlled trial, *J Clin Endocrinol Metabol* 86:1626, 2001.
546. **Ehrmann DA, Schneider DJ, Sobel BE**, et al., Troglitazone improves defects in insulin action, insulin secretion, ovarian steroidogenesis, and fibrinolysis in women with polycystic ovary syndrome, *J Clin Endocrinol Metabol* 82:2108, 1997.
547. **Dunaif A, Scott D, Finegood D, Quintana B, Whitcomb R**, The insulin-sensitizing agent troglitazone improves metabolic and reproductive abnormalities in the polycystic ovary syndrome, *J Clin Endocrinol Metabol* 81:3299, 1996.
548. **Legro RS, Zaino RJ, Demers LM**, et al., The effects of metformin and rosiglitazone, alone and in combination, on the ovary and endometrium in polycystic ovary syndrome, *Am J Obstet Gynecol* 196:402.e1, 2007.
549. **Glintborg D, Hermann AP, Andersen M, Hagen C, Beck-Nielsen H, Veldhuis JD, Henriksen JE**, Effect of pioglitazone on glucose metabolism and luteinizing hormone secretion in women with polycystic ovary syndrome, *Fertil Steril* 86:385, 2006.
550. **Koo YA, Shin SY, Yoon BK, Choi D**, Pioglitazone for treating polycystic ovary syndrome in non-obese women of reproductive age with different clinical presentations, *Gynecol Endocrinol* 23:461, 2007.
551. **Aroda VR, Ciaraldi TP, Burke P, Mudaliar S, Clopton P, Phillips S, Chang RJ, Henry RR**, Metabolic and hormonal changes induced by pioglitazone in polycystic ovary syndrome: a randomized, placebo-controlled clinical trial, *J Clin Endocrinol Metabol* 94:469, 2009.
552. **Jayasena CN, Franks S**, The management of patients with polycystic ovary syndrome, *Nat Rev Endocrinol* 10:624, 2014.
553. **Kennedy S, Bergqvist A, Chapron C**, et al., ESHRE guideline for the diagnosis and treatment of endometriosis, *Hum Reprod* 20:2698, 2005.
554. **Meier JJ, Nauck MA**, Incretin-based therapies: where will we be 50 years from now? *Diabetologia* 58:1745, 2015.
555. **Niafar M, Pourafkari L, Porhomayon J, Nader N**, A systematic review of GLP-1 agonists on the metabolic syndrome in women with polycystic ovaries, *Arch Gynecol Obstet* 293:509, 2016.
556. **Elkind-Hirsch KE, Paterson MS, Seidemann EL, Gutowski HC**, Short-term therapy with combination dipeptidyl peptidase-4 inhibitor saxagliptin/metformin extended release (XR) is superior to saxagliptin or metformin XR monotherapy in prediabetic women with polycystic ovary syndrome: a single-blind, randomized, pilot study, *Fertil Steril* 107:253.e1, 2017.
557. **Mastorakos G, Koliopoulos C, Creatsas G**, Androgen and lipid profiles in adolescents with polycystic ovary syndrome who were treated with two forms of combined oral contraceptives, *Fertil Steril* 77:919, 2002.
558. **Diamanti-Kandarakis E, Baillargeon J-P, Iuorno MJ, Jakubowicz DJ, Nestler JE**, A modern medical quandary: polycystic ovary syndrome, insulin resistance, and oral contraceptive pills, *J Clin Endocrinol Metabol* 88:1927, 2003.
559. **Ibáñez L, de Zegher F**, Flutamide-metformin therapy to reduce fat mass in hyperinsulinemic ovarian hyperandrogenism: effects in adolescents and in women on third-generation oral contraception, *J Clin Endocrinol Metabol* 88:4720, 2003.
560. **Ibáñez L, de Zegher F**, Ethinylestradiol-drospirenone, flutamide-metformin, or both for adolescents and women with hyperinsulinemic hyperandrogenism: opposite effects on adipocytokines and body adiposity, *J Clin Endocrinol Metabol* 89:1592, 2004.
561. **Rautio K, Tapanainen JS, Ruokonen A, Morin-Papunen LC**, Effects of metformin and ethinyl estradiol-cyproterone acetate on lipid levels in obese and non-obese women with polycystic ovary syndrome, *Eur J Endocrinol* 152: 269, 2005.
562. **Mitkov M, Pehlivanov B, Terzieva D**, Combined use of metformin and ethinyl estradiol-cyproterone

acetate in polycystic ovary syndrome, *Eur J Obstet Gynecol Reprod Biol* 118:209, 2005.

563. **Duleba AJ, Banaszewska B, Spaczynski RZ, Pawelczyk L**, Simvastatin improves biochemical parameters in women with polycystic ovary syndrome: results of a prospective, randomized trial, *Fertil Steril* 85:996, 2006.
564. **Banaszewska B, Pawelczyk L, Spaczynski RZ, Dziura J, Duleba AJ**, Effects of simvastatin and oral contraceptive agent on polycystic ovary syndrome: prospective, randomized, crossover trial, *J Clin Endocrinol Metabol* 92:456, 2007.
565. **Sathyapalan T, Kilpatrick ES, Coady A-M, Atkin SL**, The effect of atorvastatin in patients with polycystic ovary syndrome: a randomized double-blind placebo-controlled study, *J Clin Endocrinol Metabol* 94:103, 2009.
566. **Banaszewska B, Pawelczyk L, Spaczynski RZ, Duleba AJ**, Comparison of simvastatin and metformin in treatment of polycystic ovary syndrome: prospective randomized trial, *J Clin Endocrinol Metabol* 94:4938, 2009.
567. **Goldstein JL, Brown MS**, Regulation of the mevalonate pathway, *Nature* 343:425, 1990.
568. **Izquierdo D, Foyouzi N, Kwintkiewicz J, Duleba AJ**, Mevastatin inhibits ovarian theca–interstitial cell proliferation and steroidogenesis, *Fertil Steril* 82:1193, 2004.
569. **Edison RJ, Muenke M**, Mechanistic and epidemiologic considerations in the evaluation of adverse birth outcomes following gestational exposure to statins, *Am J Med Genet* 131A:287, 2004.
570. **Muscogiuri G, Mitri J, Mathieu C**, et al., Mechanisms in endocrinology: vitamin D as a potential contributor in endocrine health and disease, *Eur J Endocrinol* 171:R101, 2014.
571. **Akbari M, Ostadmohammadi V, Lankarani KB**, et al., The effects of vitamin D supplementation on biomarkers of inflammation and oxidative stress among women with polycystic ovary syndrome: a systematic review and meta-analysis of randomized controlled trials, *Horm Metab Res* 50(4):271, 2018.
572. **Rocha ALL, Faria LC, Guimaraes TCM**, et al., Non-alcoholic fatty liver disease in women with polycystic ovary syndrome: systematic review and meta-analysis, *J Endocrinol Invest* 40:1279, 2017.
573. **Setji TL, Holland ND, Sanders LL, Pereira KC, Diehl AM, Brown AJ**, Nonalcoholic steatohepatitis and nonalcoholic fatty liver disease in young women with polycystic ovary syndrome, *J Clin Endocrinol Metab* 91:1741, 2006.
574. **Kahal H, Kyrou I, Tahrani AA, Randeve HS**, Obstructive sleep apnoea and polycystic ovary syndrome: a comprehensive review of clinical interactions and underlying pathophysiology, *Clin Endocrinol (Oxf)* 87:313, 2017.
575. **Zhou XS, Rowley JA, Demirovic F, Diamond MP, Badr MS**, Effect of testosterone on the apneic threshold in women during NREM sleep, *J Appl Physiol (1985)* 94:101, 2003.
576. **Lindberg E, Theorell-Haglow J, Svensson M, Gislason T, Berne C, Janson C**, Sleep apnea and glucose metabolism: a long-term follow-up in a community-based sample, *Chest* 142:935, 2012.
577. **Dunaif A, Graf M, Mandeli J, Laumas V, Dobrjansky A**, Characterization of groups of hyperandrogenic women with acanthosis nigricans, impaired glucose tolerance, and/or hyperinsulinemia, *J Clin Endocrinol Metabol* 65:499, 1987.
578. **Chang RJ, Nakamura RM, Judd HL, Kaplan SA**, Insulin resistance in nonobese patients with polycystic ovarian disease, *J Clin Endocrinol Metabol* 57:356, 1983.
579. **Dunaif A, Segal KR, Futterweit W, Dobrjansky A**, Profound peripheral insulin resistance, independent of obesity, in polycystic ovary syndrome, *Diabetes* 38:1165, 1989.
580. **Dunaif A, Segal KR, Shelley DR, Green G, Dobrjansky A, Licholai T**, Evidence for distinctive and intrinsic defects in insulin action in polycystic ovary syndrome, *Diabetes* 41:1257, 1992.
581. **Jahanfar S, Eden JA, Warren P, Seppälä M, Nguyen TV**, A twin study of polycystic ovary syndrome, *Fertil Steril* 63:478, 1995.
582. **Campbell PJ, Gerich JE**, Impact of obesity on insulin action in volunteers with normal glucose tolerance: demonstration of a threshold for the adverse effect of obesity, *J Clin Endocrinol Metabol* 70:1114, 1990.
583. **Bjorntorp PER**, The android woman—a risky condition, *J Intern Med* 239:105, 1996.
584. **Holte J, Gennarelli G, Wide L, Lithell H, Berne C**, High prevalence of polycystic ovaries and associated clinical, endocrine, and metabolic features in women with previous gestational diabetes mellitus, *J Clin Endocrinol Metabol* 83:1143, 1998.
585. **Talbott E, Guzick D, Clerici A, Berga S, Detre K, Weimer K, Kuller L**, Coronary heart disease risk

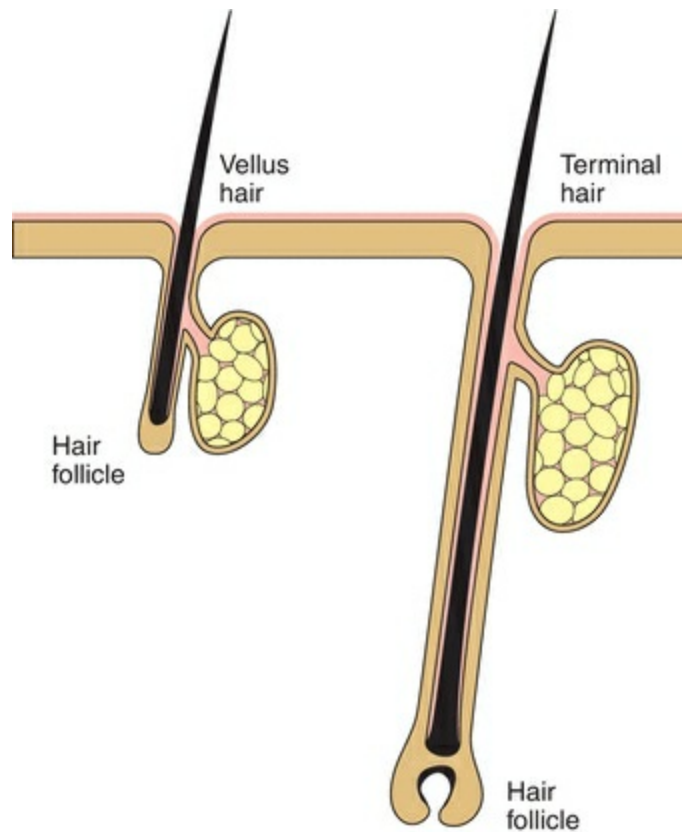
- factors in women with polycystic ovary syndrome, *Arterioscler Thromb Vasc Biol* 15:821, 1995.
586. **Wild RA**, Obesity, lipids, cardiovascular risk, and androgen excess, *Am J Med* 98:S27, 1995.
587. **Wild RA, Alaupovic P, Parker IJ**, Lipid and apolipoprotein abnormalities in hirsute women, *Am J Obstet Gynecol* 166:1191, 1992.
588. **Reaven GM**, Relationship between insulin resistance and hypertension, *Diabetes Care* 14:33, 1991.
589. **Velazquez EM, Mendoza SG, Wang P, Glueck CJ**, Metformin therapy is associated with a decrease in plasma plasminogen activator inhibitor-1, lipoprotein(a), and immunoreactive insulin levels in patients with the polycystic ovary syndrome, *Metabolism* 46:454, 1997.
590. **Diamanti-Kandarakis E, Spina G, Kouli C, Migdalis I**, Increased endothelin-1 levels in women with polycystic ovary syndrome and the beneficial effect of metformin therapy, *J Clin Endocrinol Metabol* 86:4666, 2001.
591. **Dahlgren E, Landin K, Krotkiewski M, Holm G, Janson PO**, Effects of two antiandrogen treatments on hirsutism and insulin sensitivity in women with polycystic ovary syndrome, *Hum Reprod* 13:2706, 1998.
592. **Godsland IF, Walton C, Felton C, Proudler A, Patel A, Wynn V**, Insulin resistance, secretion, and metabolism in users of oral contraceptives, *J Clin Endocrinol Metabol* 74:64, 1992.
593. **Chasan-Taber L, Willett WC, Stampfer MJ**, et al., A prospective study of oral contraceptives and NIDDM among U.S. women, *Diabetes Care* 20:330, 1997.
594. **Rimm EB, Manson JE, Stampfer MJ**, et al., Oral contraceptive use and the risk of type 2 (non-insulin-dependent) diabetes mellitus in a large prospective study of women, *Diabetologia* 35:967, 1992.
595. **WHO Collaborative Study of Cardiovascular Disease and Steroid Hormone Contraception**, Acute myocardial infarction and combined oral contraceptives: results of an international multicentre case-control study, *Lancet* 349: 1202, 1997.
596. **Croft P, Hannaford PC**, Risk factors for acute myocardial infarction in women: evidence from the Royal College of General Practitioners' oral contraception study, *BMJ* 298:165, 1989.
597. **Sidney S, Bpetitti D, Pquesenberryjr C, Lklatsky A, Kziel H, Wolf S**, Myocardial infarction in users of low-dose oral contraceptives, *Obstet Gynecol* 88:939, 1996.
598. **Lewis MA, Heinemann LAJ, Spitzer WO, MacRae KD, Bruppacher R**, The use of oral contraceptives and the occurrence of acute myocardial infarction in young women, *Contraception* 56:129, 1997.
599. **Dunaif A, Green G, Phelps RG, Lebwohl M, Futterweit W, Lewy L**, Acanthosis nigricans, insulin action, and hyperandrogenism: clinical, histological, and biochemical findings, *J Clin Endocrinol Metabol* 73:590, 1991.
600. **Sharma S, Wickham E, Nestler J**, Changes in glucose tolerance with metformin treatment in polycystic ovary syndrome: a retrospective analysis, *Endocr Pract* 13:373, 2007.
601. **Feng W, Jia YY, Zhang DY, Shi HR**, Management of polycystic ovarian syndrome with Diane-35 or Diane-35 plus metformin, *Gynecol Endocrinol* 32:147, 2016.
602. **Diamanti-Kandarakis E, Economou F, Palimeri S, Christakou C**, Metformin in polycystic ovary syndrome, *Ann N Y Acad Sci* 1205:192, 2010.
603. **Ibanez L, Dimartino-Nardi J, Potau N, Saenger P**, Premature adrenarche—normal variant or forerunner of adult disease? *Endocr Rev* 21:671, 2000.
604. **Hickey M, Doherty DA, Atkinson H**, et al., Clinical, ultrasound and biochemical features of polycystic ovary syndrome in adolescents: implications for diagnosis, *Hum Reprod* 26:1469, 2011.
605. **Williams RM, Ong KK, Dunger DB**, Polycystic ovarian syndrome during puberty and adolescence, *Mol Cell Endocrinol* 373:61, 2013.
606. **Lewy VD, Danadian K, Witchel SF, Arslanian S**, Early metabolic abnormalities in adolescent girls with polycystic ovarian syndrome, *J Pediatr* 138:38, 2001.
607. **Palmert MR, Gordon CM, Kartashov AI, Legro RS, Emans SJ, Dunaif A**, Screening for abnormal glucose tolerance in adolescents with polycystic ovary syndrome, *J Clin Endocrinol Metabol* 87:1017, 2002.
608. **Li J, Eriksson M, Czene K, Hall P, Rodriguez-Wallberg KA**, Common diseases as determinants of menopausal age, *Hum Reprod* 31:2856, 2016.
609. **Carmina E, Campagna AM, Lobo RA**, Emergence of ovulatory cycles with aging in women with polycystic ovary syndrome (PCOS) alters the trajectory of cardiovascular and metabolic risk factors, *Hum Reprod*



28:2245, 2013.

# Hirsutism

**Hirsutism** (Latin origin) is defined as excessive growth of **terminal** or coarse hair in a male-pattern distribution on the face and body and affects between 5% and 10% of reproductive age women.<sup>1</sup> Circulating androgen levels (discussed in detail in [Chapters 11 and 13](#)) are often, although not always, elevated, and hirsutism can be the initial or the only sign of androgen excess. Hirsutism in the setting of normal circulating androgen profile is termed “idiopathic.” Hirsutism is most frequently seen in women with polycystic ovary syndrome (PCOS, reviewed in [Chapter 11](#)). Unlike hirsutism, **hypertrichosis** (Greek origin) refers to a generalized overgrowth of soft, fine vellus hair ([Figure 12.1](#)) and is not caused by androgen excess but rather may be genetic or result from exposure to certain medications. **Virilization** describes the signs and symptoms of more severe androgen excess, which include deepening of the voice, temporal male-pattern balding (androgenic alopecia), breast atrophy, changes in body habitus that include an increase in muscle mass, and clitoromegaly. Unlike hirsutism, virilization is rare and most commonly results from congenital adrenal hyperplasia (CAH) or androgen-producing tumors of the ovary or adrenal (discussed in [Chapter 13](#)).



**FIGURE 12.1**

Hirsutism is both an endocrine and a cosmetic problem that can contribute to significant psychological stress and deserves a concerned and sympathetic response. Excessive hair growth on the face, chest, or abdomen may be quite distressing and raises a number of concerns about the possibility of underlying disease, effects on body image and fertility, and questions about availability and efficacy of existing treatments.

This chapter reviews the biology of hair growth and the causes and pathophysiology of hirsutism and presents a simplified, evidence-based approach to the diagnostic evaluation and effective clinical management.

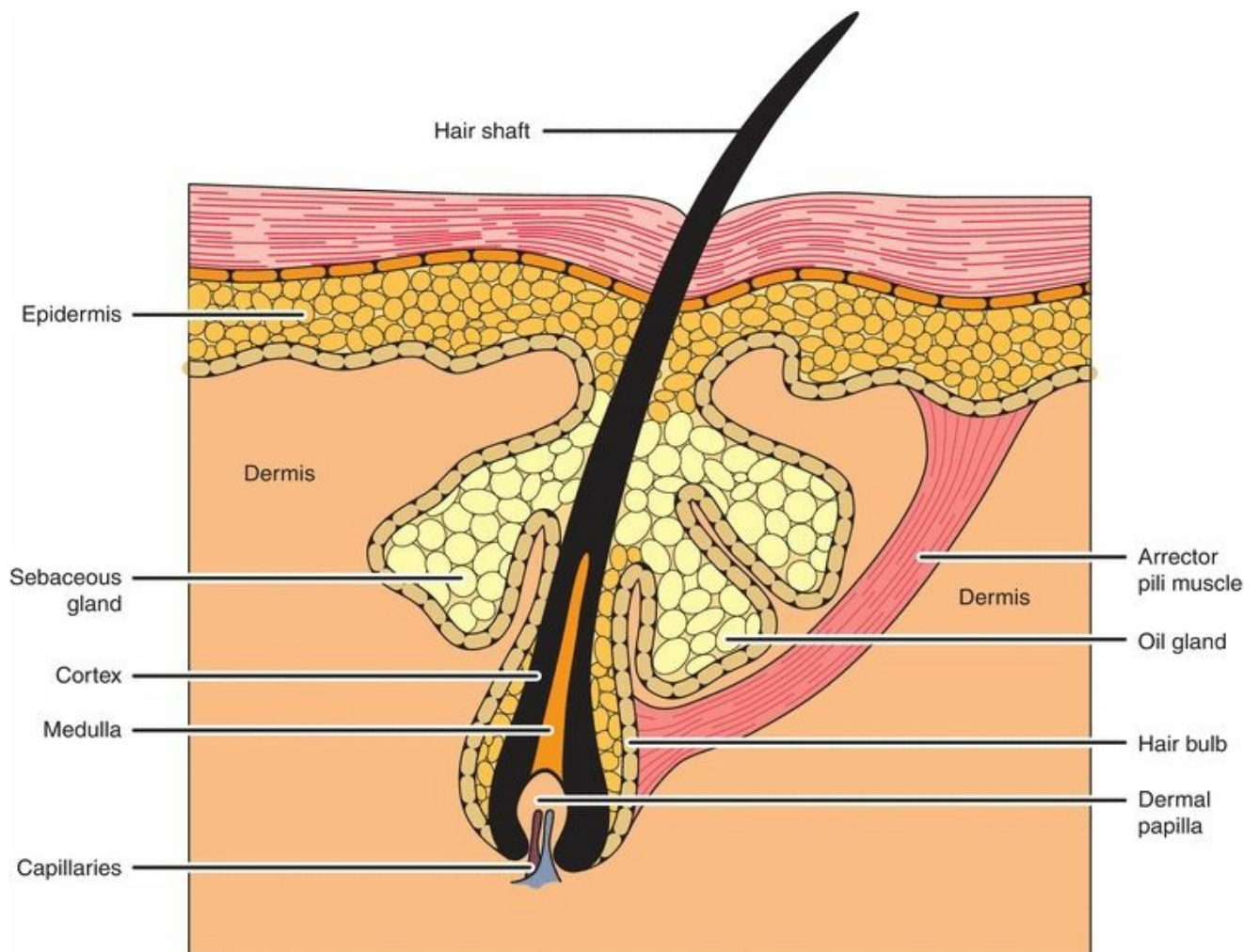
# THE BIOLOGY OF HAIR GROWTH

---

Hair is a distinguishing characteristic of mammals and serves a wide range of functions, including thermoregulation, physical protection, sensory activity, and social interactions. Androgens are required for development of sexual hair and sebaceous glands, but numerous other factors are also involved, including growth hormone, insulin, insulin-like growth factors (IGFs), glucocorticoids, estrogen, and thyroid hormones.<sup>2,3</sup>

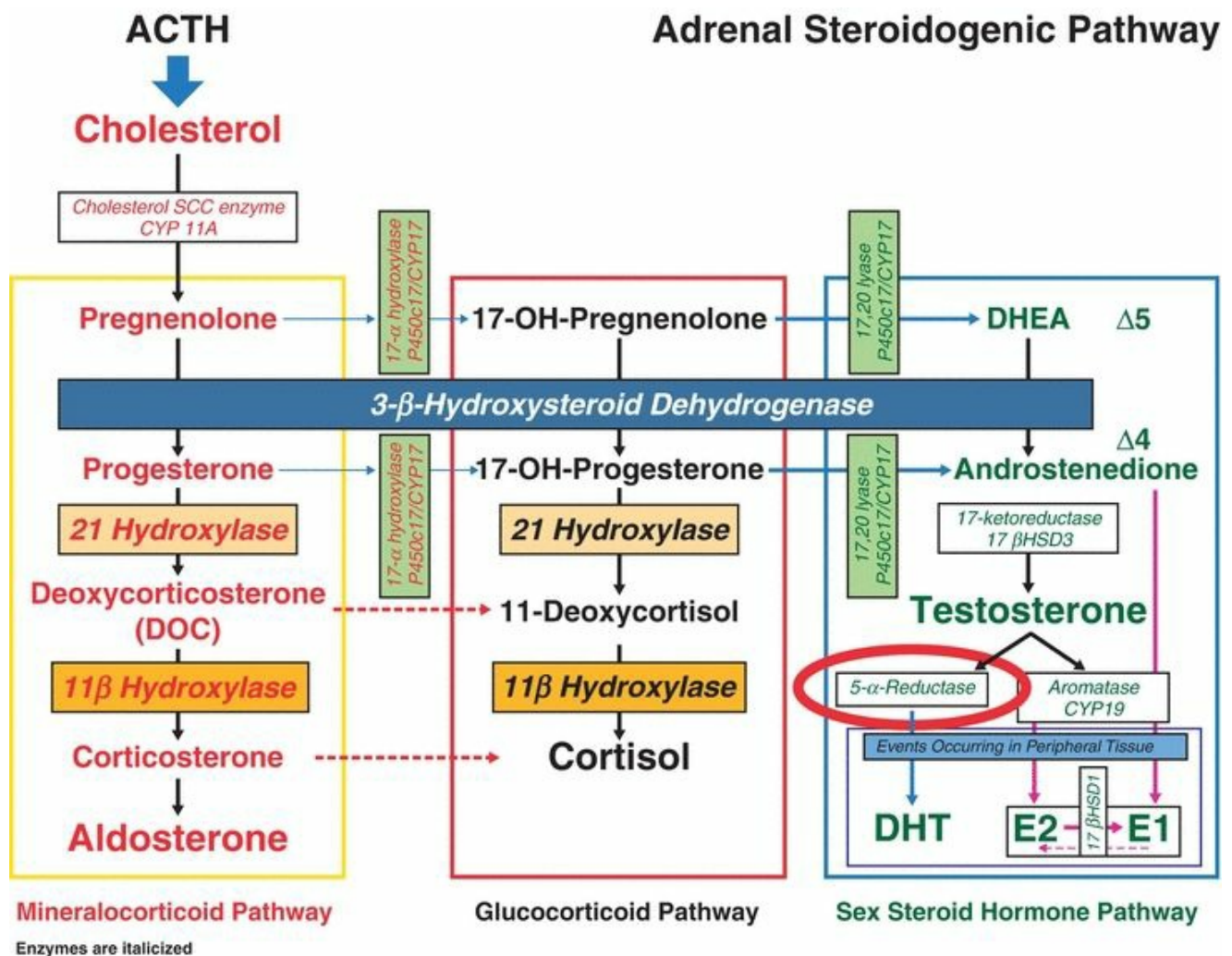
# Embryology

Hair follicles develop at approximately 8–10 weeks of gestation from a small group of epidermal cells overlying undifferentiated mesenchyme. Members of the transforming growth factor beta (TGF $\beta$ ) superfamily, activins and bone morphogenetic proteins (BMPs) in particular, play an important role in the communication between the epithelial and the mesenchymal compartments during normal hair follicle development.<sup>4,5</sup> Initially, the hair follicle is composed of a solid column of cells that proliferates from the basal layers of the epidermis and extends downward into the dermis. As the column elongates, it encounters a cluster of mesenchymal cells (the dermal papilla) that envelop its bulbous tip (bulb). The solid epithelial column then hollows to create a hair canal, and the **pilosebaceous unit (PSU)** is formed. A PSU is composed of a hair follicle, the adjoining sebaceous gland, and the arrector pili (**Figure 12.2**), a small muscle that connects the hair follicle to the dermis, and when it contracts, it causes the hair to “stand” such as occurs in fear or following exposure to cold. Hair color is determined by the pigments produced by melanocytes located in the hair bulb.



**FIGURE 12.2**

One's total endowment of hair follicles is determined by 22 weeks of gestation, and no new hair follicles develop de novo thereafter. The concentration of hair follicles in facial skin does not differ significantly between the sexes but does differ between races and ethnic groups. Whereas Asian and Native American women generally have little body hair, women of Mediterranean descent typically have increased amounts of body hair, although serum androgen concentrations are similar in the three groups.<sup>6</sup> Differences in hair growth among races and ethnic groups probably also reflect differences in the local levels of 5 $\alpha$ -reductase activity, the enzyme that converts testosterone to the more potent and active androgen, dihydrotestosterone (DHT)<sup>7</sup> (Figure 12.3).



**FIGURE 12.3**

# The Hair Growth Cycle

Hair growth is cyclic, rather than continuous, and exhibits three distinct phases, known as **anagen** (growth phase), **catagen** (involution phase), and **telogen** (quiescent or resting phase)<sup>2</sup> (Figure 12.4). As growth (anagen) begins, cells in the epithelial matrix at the base of the hair follicle begin to proliferate, extending downward into the dermis in a column that elongates to approximately 4–6 times its resting length. With continued rapid growth, the epithelial column also pushes upward to the skin surface, breaking its tenuous contact with the previous hair, which gets shed. The most superficial epithelial cells differentiate to form a keratinized column, and growth continues as long as active mitosis persists in the basal epithelial cells. As the growth phase comes to a close, the column rapidly shrinks and the bulb at the base of the epithelial canal shrivels (catagen) before the hair follicle enters a quiescent phase (telogen).



**FIGURE 12.4**

The length of hair is determined primarily by the duration of the anagen (growth) phase. Scalp hair remains in anagen for 2–5 years and spends only a relatively short time in telogen (rest). Elsewhere, such as on the forearm, the hair cycle has a short anagen and a

long telogen, yielding a short hair of relatively stable length. The outward appearance of continuous growth or periodic shedding reflects the extent to which hair follicles act in synchrony with others in the area. Typically, scalp hair are asynchronous and, therefore, always appear to be growing; the resting phase of some hair (approximately 10–15%) is not apparent. If a larger proportion of hair becomes synchronous and enters telogen simultaneously, excess shedding may occur, a process known as **telogen effluvium**. Although women occasionally may notice and complain of scalp hair loss, the interval of shedding usually lasts no longer than 6–8 months. Growth resumes when asynchrony again becomes established. Telogen effluvium can be precipitated by pregnancy, by certain drugs including hormonal contraceptives, by febrile illness, and even by significant psychological stress.

Based on physical characteristics, bodily hair are categorized as **vellus** (fine, soft, short, and unpigmented) or **terminal** (long, coarse, and pigmented, see [Figure 12.1](#)).<sup>3</sup> Vellus hair that cover the body of infants are called **lanugo**. **Hypertrichosis** describes an uncommon condition characterized by a generalized increase in vellus body hair, usually associated with drugs (e.g., phenytoin, penicillamine, diazoxide, minoxidil, cyclosporine), systemic illness (e.g., hypothyroidism, anorexia nervosa, malnutrition, porphyria, dermatomyositis), or malignancy (as a paraneoplastic syndrome). Hirsutism implies an irreversible transformation from vellus to terminal hair.

## The Control of Hair Growth

The fate of a hair follicle depends on the health and function of the dermal papilla. Despite major injury to its epithelial component (e.g., from freezing or damage from x-rays), the hair follicle will regenerate and regrow the hair shaft provided the dermal papilla survives intact. Serious injury or degeneration of the dermal papilla (e.g., electrolysis or laser hair removal) results in permanent hair loss.

**Sexual hair are those which responds to sex steroids and grow primarily on the face, chest, lower abdomen, the pubis, and in the axillae.** In androgen-sensitive areas, androgens, particular if in excess, stimulate hair follicles, inducing the growth of thicker, longer, and darker hairs. **Thereafter, the hair exhibits typical cycles of growth, involution, and rest. However, once transformed from vellus to terminal fate, the coarse texture of the terminal hair does not revert back to the soft and fine vellus character, even if the androgen levels normalize.** Because androgen stimulation of hair follicles requires the conversion of testosterone to DHT, the sensitivity of hair follicles to androgens is determined, in part, by the local level of 5 $\alpha$ -reductase activity in the vicinity of the PSU, helping to explain the varying extent of hirsutism observed in women with similar serum androgen levels.<sup>8</sup>

**Based on data from animal studies and on patterns of human disease, the**



## following summarizes the effects of steroid hormones on hair growth:

1. Androgens, particularly testosterone, stimulate growth and increase the diameter and pigmentation of hair. Androgens also increase the proportion of time terminal hairs spend in anagen,<sup>9</sup> except on the scalp, where androgen decreases the duration of anagen.
2. Estrogens have actions opposite those of androgens, generally resulting in slower growth of finer and lighter hair.
3. Natural progesterone has little or no direct effect on hair growth. Synthetic progestins, particularly the 19-nortestosterone derivatives, may exert androgen like effects at the PSU.
4. Pregnancy, characterized by high levels of both estrogen and progesterone, can induce greater synchrony among hair follicles, leading to finite periods of synchronized growth (hair density appears to improve) followed by shedding (excessive hair shedding becomes apparent).

Observations in studies of the effects of male castration demonstrate an important clinical characteristic of hair growth. Males castrated before puberty do not grow a beard or other sexual hair, but when castrated after puberty is completed, the beard and sexual hair continue to grow, albeit more slowly and with finer caliber of hair.

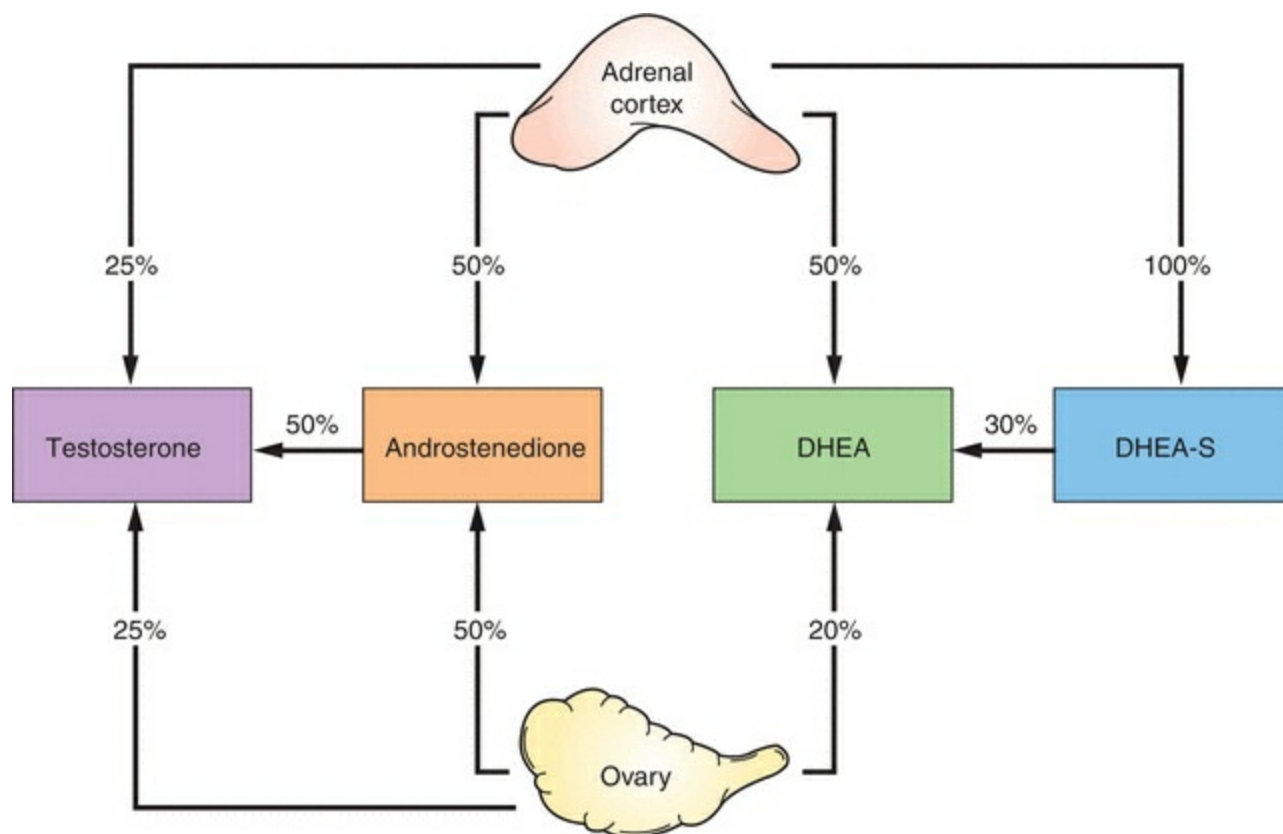
Endocrine disorders can affect the growth of both sexual and nonsexual hair. Hair growth is markedly reduced in individuals with hypopituitarism. Hypothyroidism sometimes is associated with hair loss on the scalp, the pubis, in the axillae, and, curiously, the lateral third of the eyebrows. Hyperthyroidism generally results in finer hair that are lost easily. Approximately 10–15% of patients with acromegaly are hirsute. IGF-1, which stimulates  $5\alpha$ -reductase activity,<sup>10</sup> often is increased in women with chronic anovulation, insulin resistance, and hyperinsulinemia.

Hair growth also can be influenced by other factors, such as local skin temperature, blood flow, and edema. Hair grow faster in the summer than in the winter.<sup>11</sup> Hair growth also can be observed in association with central nervous system pathology (e.g., encephalitis, cranial trauma, multiple sclerosis) and with certain drugs. Hair loss and thinning can be associated with micronutrient deficiencies, such as iron, biotin, folate, and B12 deficiencies.

# ANDROGENS IN WOMEN

Hirsutism reflects the interaction between circulating androgen levels and the sensitivity of hair follicles to androgen stimulation. Sources and types of androgens in women are discussed in detail in [Chapter 13](#) and [Chapter 11](#) and are briefly reviewed here. In women, the major circulating androgens (in descending order of serum concentration) are dehydroepiandrosterone sulfate (DHEA-S), dehydroepiandrosterone (DHEA), androstenedione, testosterone, and DHT ([Figure 12.3](#)).<sup>12</sup>

**Figure 12.5** outlines the sources and respective organ contributions to the circulating pool of androgens in women. **DHEA-S, DHEA, and androstenedione can be considered prehormones because they have little or no intrinsic androgenic activity and require conversion to testosterone to exert androgenic effects.**



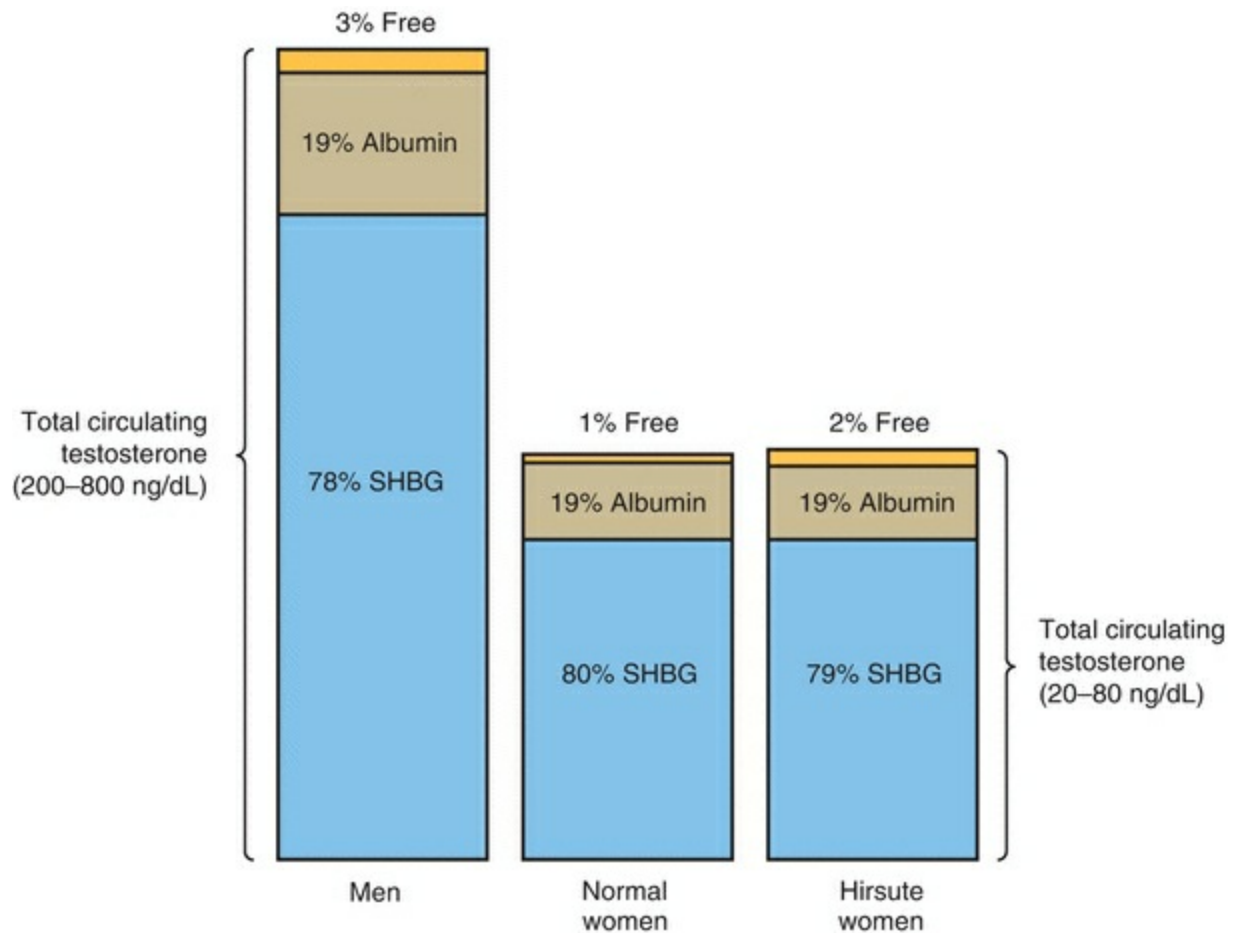
**FIGURE 12.5**

DHEA-S is produced almost exclusively by the adrenal glands, at a rate ranging between 3.5 and 20 mg/day<sup>13</sup>; the normal serum concentration is 100–350 µg/dL in most laboratories. DHEA is produced by both the adrenals (50%) and the ovaries (20%) and from the peripheral conversion of DHEA-S (30%). The production rate of DHEA is

between 6 and 8 mg/day,<sup>14</sup> and normal serum concentrations range between 1 and 10 ng/mL. Androstenedione production is divided equally between the ovaries and the adrenals; the production rate is between 1.4 and 6.2 mg/day, and the normal serum concentration is 0.5–2.0 ng/mL.<sup>15,16</sup>

Testosterone production derives from the adrenals (25%), the ovaries (25%), and from peripheral conversion of androstenedione (50%). The production rate ranges between 0.1 and 0.4 mg/day, and the normal serum concentration is 20–80 ng/dL; levels do not fluctuate widely but are lowest during the early follicular phase, and approximately 20% higher at midcycle.<sup>14</sup> In normal women, about 80% of circulating testosterone is bound to a beta globulin known as **sex hormone–binding globulin (SHBG)**, another 19% is loosely bound to albumin, leaving only about 1% unbound or free. Routine serum immunoassays for testosterone measure the total testosterone concentration, including both bound and unbound hormone. However, the androgenic actions of testosterone relate primarily to the amount of free hormone and, to a limited extent, to the fraction associated with albumin. Anything that affects the SHBG concentration also affects the concentration of free/active testosterone. Serum immunoassays for DHEA-S, DHEA, and androstenedione generally reflect the amount of biologically available hormone because unlike testosterone, none of these three is protein bound to any significant extent.

Androgens themselves decrease SHBG production in the liver. Consequently, testosterone binding capacity in men is lower than in normal women; approximately 3% of total testosterone circulates in the free, active form in men. Whereas insulin and glucocorticoids also decrease SHBG levels, estrogens and thyroid hormone increase SHBG production. Therefore, binding capacity is increased in women with hyperthyroidism, in pregnancy, and during treatment with estrogens. In hirsute women, excess androgen production (and hyperinsulinemia, when present) depresses SHBG levels, increasing the amount of free/active testosterone to approximately 2%, even though the total testosterone level may remain within the normal range. **Although specific assays to measure the level of free testosterone are available, they are costly and rarely necessary. The very presence of hirsutism or virilization indicates androgen excess. In hirsute women with “normal” serum total testosterone levels, decreased binding capacity and increased free testosterone can be assumed (Figure 12.6).**



**FIGURE 12.6**

In women with hirsutism, only about 25% of circulating testosterone arises from peripheral conversion; rather, most comes from direct secretion, with the ovary being the primary source of both increased testosterone and androstenedione.<sup>17</sup> By far, the most common cause of hirsutism is PCOS (discussed in [Chapter 11](#)), with the excess androgen production occurring in the ovaries. Adrenal causes of hyperandrogenemia (discussed in [Chapter 13](#)) as a cause of hirsutism are uncommon.

Although testosterone is the major circulating androgen, DHT is the major nuclear androgen in many androgen-sensitive tissues, including the hair follicles and sebaceous glands. DHT is produced only in the periphery, by intracellular conversion of testosterone (via the enzyme  $5\alpha$ -reductase). Circulating levels of DHT, therefore, do not reflect the tissue level of  $5\alpha$ -reductase activity.<sup>18</sup>  $3\alpha$ -Androstanediol is the peripheral tissue metabolite of DHT, and its glucuronide conjugate,  $3\alpha$ -androstanediol glucuronide ( $3\alpha$ -AG), can be used as a marker of peripheral androgen metabolism.<sup>19,20</sup> **Serum  $3\alpha$ -AG levels correlate highly with levels of  $5\alpha$ -reductase activity in the genital skin and are elevated almost uniformly in hirsute women,<sup>21</sup> including those with normal**

**serum androgen levels, indicating that “idiopathic” hirsutism likely results from increased peripheral 5 $\alpha$ -reductase activity.** After the menopause, the production rate and serum concentration of androstenedione fall by about half, with approximately 80% derived from the adrenals.<sup>22</sup> Testosterone production and serum levels also decline, primarily due to the decrease in peripheral production (i.e., via the conversion of androstenedione).<sup>23,24</sup> **Ovarian testosterone production is largely maintained after the menopause,** as demonstrated by the 40–50% decrease in serum testosterone levels after oophorectomy in postmenopausal women.<sup>25,26</sup> Because the decrease in estrogen production far exceeds that in androgen production after menopause, the postmenopausal ovary is primarily an androgen-producing organ.<sup>27</sup> The elevated pituitary gonadotropin levels that are a hallmark of menopausal state stimulate androgen synthesis in ovarian hilar and stromal cells.<sup>28,29</sup> Unlike the ovaries, the adrenal androgen production declines progressively with age; serum DHEA concentrations in women between ages 40 and 50 years are approximately half those in younger women.<sup>30</sup>

# CAUSES OF HIRSUTISM

---

In reproductive age women, PCOS (discussed in [Chapter 11](#)) is probably the most common cause of hirsutism. Almost 5–10% of cases, however, represent idiopathic hirsutism (IH). Other less common causes of hirsutism include specific endocrine disorders, such as classical and nonclassical CAH, androgen-secreting ovarian or adrenal tumors, Cushing syndrome, and the hyperandrogenic insulin-resistant acanthosis nigricans (HAIR-AN) syndrome. In a case series of 873 women presenting with symptoms of androgen excess, the prevalence of these disorders is described in [Table 12.1](#).<sup>31</sup>

## TABLE 12.1 Causes of Hirsutism

Diagnosis	Number	Prevalence (%)
<b>Specific Disorders</b>		
Androgen-secreting neoplasm	2	0.23
Classical congenital adrenal hyperplasia	6	0.69
Nonclassical congenital adrenal hyperplasia	18	2.06
HAIR-AN syndrome	33	3.78
<b>Disorders of Exclusion</b>		
Polycystic ovary syndrome	716	82.02
Idiopathic hirsutism	39	4.47
Hyperandrogenemia, hirsutism, and normal ovulation	59	6.75
<b>Total</b>	<b>873</b>	<b>100.00</b>

**PCOS is by far the most common cause of androgen excess in women.** The diagnostic criteria, clinical features, and treatment of PCOS are considered in-depth in [Chapter 11](#). The prevalence of PCOS among populations of hirsute women varies with differences in the diagnostic criteria proposed by the National Institutes of Health Conference on PCOS (The NIH Criteria, NIH, 1990),<sup>32</sup> the European Society of Human Reproduction and Embryology/American Society for Reproductive Medicine Consensus Workshop Group (The Rotterdam Criteria, ESHRE/ASRM, 2003),<sup>33</sup> and the Androgen

Excess Society (The AE-PCOS Criteria, AES, 2009).<sup>34</sup> All include oligo/anovulation and clinical or biochemical evidence of hyperandrogenism as diagnostic criteria, two of the three (the Rotterdam and AE-PCOS Criteria) regard polycystic ovarian morphology (as defined by ultrasonographic imaging) as a criterion, and all three require exclusion of other specific diagnoses (e.g., CAH, Cushing syndrome, androgen-secreting tumors, hypothyroidism, and hyperprolactinemia). In three large case series of women presenting with symptoms of androgen excess, the prevalence of PCOS ranged between 57% and 82%.<sup>31,35,36</sup>

**Hyperandrogenic insulin-resistant acanthosis nigricans (HAIR-AN) syndrome** has the same clinical features as PCOS but in the extreme. The primary underlying pathology is severe insulin resistance, with acanthosis nigricans being an epiphenomenon.<sup>37,38</sup> A compensatory chronic and severe hyperinsulinemia stimulates a marked increase in ovarian androgen production by signaling via theca cell receptors for insulin and IGF-1. The marked hyperinsulinemia additionally induces a profound decrease in hepatic synthesis of SHBG with suppression of serum SHBG concentrations, yielding a large increase in free testosterone levels. In turn, high circulating androgen levels exacerbate the underlying insulin resistance, resulting in a self-propagating positive feedback loop that increases in severity over time, ultimately causing severe hirsutism and, in many, even features of virilization (temporal balding, deepening of the voice, changes in body habitus, clitoromegaly). **Ovarian stromal hyperthecosis** is a histologic diagnosis, based on the observation of distinct clusters of luteinized thecal cells scattered throughout the ovarian stroma.<sup>39</sup> Patients with hyperthecosis typically are obese, severely hirsute, and often virilized, most having serum testosterone concentrations greater than 150 ng/dL and exhibiting severe insulin resistance and hyperinsulinemia.<sup>40</sup> It is likely that most, if not all, patients with the HAIR-AN syndrome have ovarian hyperthecosis. However, hyperthecosis can occur in postmenopausal women where elevated pituitary output of gonadotropins, specifically of luteinizing hormone (LH), is recognized as the driving mechanism for theca cell proliferation and testosterone production.<sup>41,42,43</sup>

**Idiopathic hirsutism** describes hirsutism in women who report regular menstrual cycles and who exhibit serum androgen levels in the normal range.<sup>8,44,45</sup> Although existence of subtle forms of ovarian or adrenal enzymatic dysfunction can be hypothesized in some with IH,<sup>46</sup> an increased sensitivity to androgens (mediated by increased peripheral 5 $\alpha$ -reductase activity)<sup>21</sup> is likely the most logical explanation, as improvement in hair growth is described with the use of inhibitors of 5 $\alpha$ -reductase. More recently, it has been appreciated that in many women previously assigned a diagnosis of IH, menstrual cycles are anovulatory despite their regularity. Thus, many previously classified as IH may in fact represent cases of PCOS.<sup>33</sup>



**Congenital adrenal hyperplasia (CAH)** is a specific but uncommon cause of hirsutism. The clinical features, diagnostic criteria, and treatment of CAH are discussed in detail in [Chapter 13](#). Whereas females with classical CAH usually are recognized at birth or during early infancy, the nonclassical form of the disorder (also known as late-onset CAH) presents later, at or after puberty, with hirsutism and menstrual irregularity or amenorrhea. In different studies, the prevalence of nonclassical CAH has ranged between 1% and 15%.<sup>47,48,49,50</sup> The most common cause of both classical and nonclassical CAH is an adrenal 21-hydroxylase (P450c21) deficiency, resulting in excess production of 17 $\alpha$ -hydroxyprogesterone (17OHP), which is a precursor for androgen synthesis ([Chapter 13](#)).

**Androgen-secreting neoplasms of the ovary or adrenal** are a rare cause of androgen excess and hirsutism. Androgen-secreting tumors account for only 5% of all ovarian tumors. Most are Sertoli-Leydig cell tumors, lipid and theca cell (stromal) tumors, or hilus cell tumors. Most are associated with frankly elevated serum testosterone concentrations (i.e., >150–200 ng/dL),<sup>51,52,53</sup> and most can be imaged by transvaginal ultrasonography. Although some adrenal adenomas secrete testosterone, most androgen-secreting adrenal tumors are carcinomas that secrete DHEA, DHEA-S, and cortisol, in addition to testosterone (discussed in [Chapter 13](#)).<sup>54</sup>

Some women with hirsutism also have mild **hyperprolactinemia**. Elevated serum prolactin concentrations can be associated with increased serum DHEA-S levels.<sup>55,56</sup> Prolactin receptors have been identified in the human adrenal, and prolactin can increase adrenal DHEA production in vitro.<sup>57</sup> Although DHEA-S is a weak androgen, it can be converted in the periphery to potent androgens such as testosterone and DHT. Prolactin stimulation of adrenal androgen production, excessive ovarian androgen production due to the chronic anovulation that often results from hyperprolactinemia (discussed in [Chapter 4](#)), and increased free testosterone levels consequent to anovulation may all be relevant to causation of hirsutism in women with chronic hyperprolactinemia.

Virilization during pregnancy should raise suspicion for a **pregnancy luteoma**, which is a hyperplastic mass of luteinized ovarian cells rather than a true tumor. Although most luteomas produce little androgen or have little or no androgenic effect, serum concentrations of androstenedione, testosterone, and DHT can be increased, sometimes dramatically<sup>58,59,60</sup>; only approximately one-third of reported pregnancy luteomas have been associated with maternal hirsutism or virilization,<sup>58,61</sup> probably because any increase in serum free testosterone is limited by the large increase in SHBG levels that occurs during pregnancy. Typically, luteomas are solid ovarian masses, yellow-brown in color and hence the name, that range in size between 6 and 10 cm; in approximately half of cases, they are bilateral.<sup>59,62</sup> Pregnancy luteomas typically

regress promptly after delivery, suggesting that the pregnancy hormone human chorionic gonadotropin (hCG) plays a role in stimulating or perpetuating their androgen production,<sup>63</sup> although most are identified late in gestation, long after the peak in maternal serum hCG concentrations ([Chapter 7](#)). Incidence of pregnancy luteomas may be higher in black compared to white women, although the mechanisms for this racial differential are unclear. In contrast to luteoma of pregnancy, **theca lutein cysts (hyperreactio luteinalis)** are functional androgen-producing ovarian cysts, which can develop during pregnancy, and almost always occur bilaterally. They are more often seen in pregnancies characterized by high maternal circulating levels of hCG, such as in women with multiple pregnancies, isoimmunized or diabetic mothers, and those with molar pregnancies or gestational trophoblastic disease. Similar to pregnancy-related luteomas discussed earlier, almost a third of women with theca lutein cysts manifest symptoms of androgen excess, which can be progressive and of varying degrees of severity. Rarely, mothers with preexisting hirsutism related to PCOS or ovarian stromal hyperthecosis also can develop theca lutein cysts and become hirsute or virilize.<sup>64,65,66</sup> In those who do, serum concentrations of testosterone and androstenedione are elevated. The placental enzyme aromatase acts as a safeguard against fetal exposure to maternal androgen excess by converting maternal testosterone and androstenedione to estrogens, although risk for virilization of a female fetus is plausible particularly when maternal hyperandrogenemia is severe and occurs early in the first trimester of pregnancy. Fetal virilization has been described more often with pregnancy luteoma compared to theca lutein cysts.<sup>58</sup>

# EVALUATION OF WOMEN WITH HIRSUTISM

---

Accepting that the large majority of women with hirsutism have PCOS or IH, the evaluation of hirsute women is aimed at quantifying the severity of hair excess and identifying the few having other causes that require additional specific evaluation and/or treatment (such as hyperprolactinemia, CAH, or androgen-secreting tumors). As always, evaluation should begin with a careful history and physical examination, which always provide important diagnostic clues. Laboratory investigation and imaging are used primarily to exclude other rare or potentially serious possibilities.

# History and Physical Examination

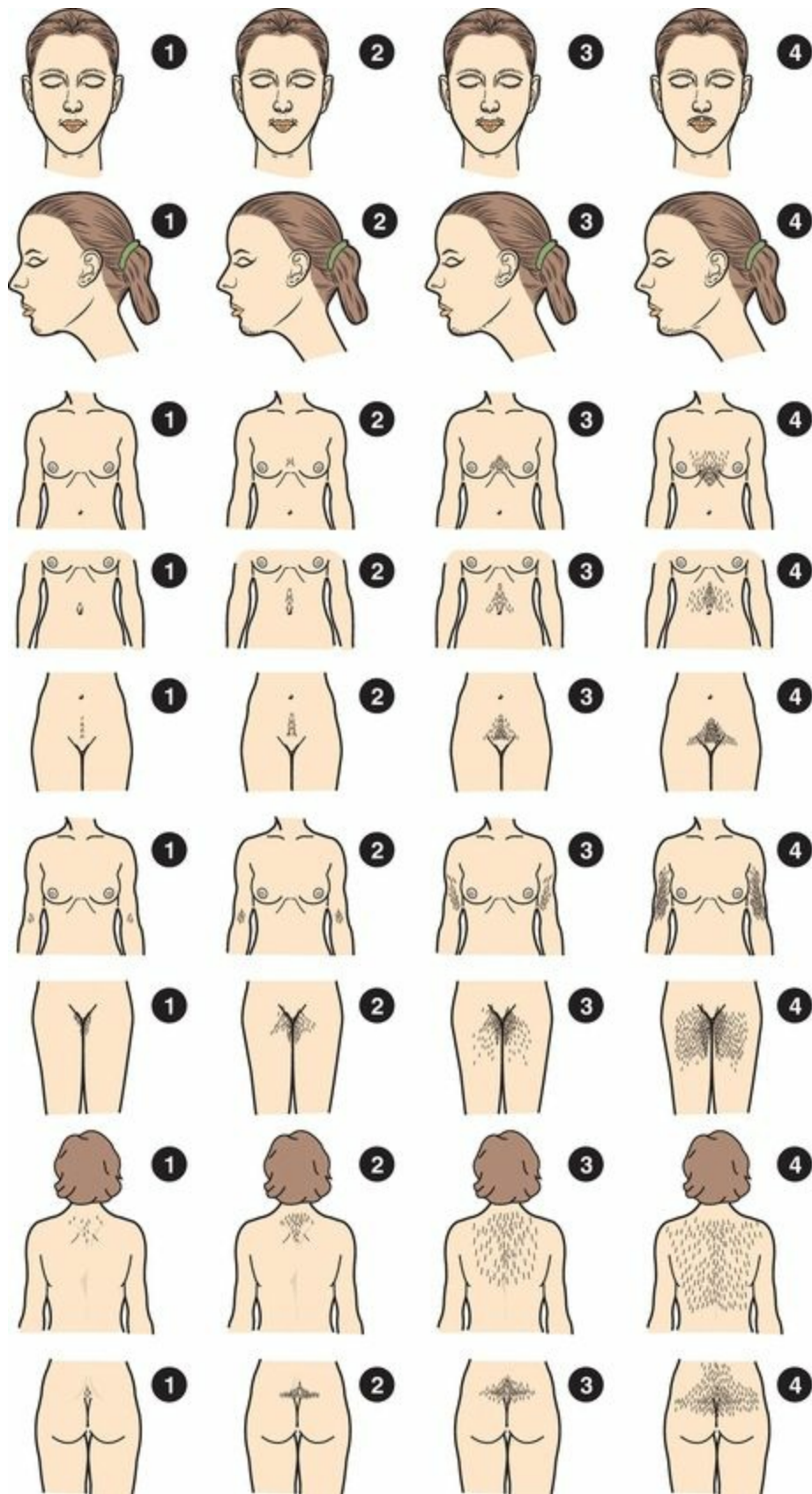
The key elements of the medical history in women with hirsutism include the menstrual history, the age at onset, and the rate of progression of hirsutism; other signs of androgen excess (such as acne and hair loss), symptoms and signs of virilization, family, and medication histories also provide important information.

The **menstrual history** should include age at menarche, the frequency as well as regularity of menses (eight or fewer menses per year is consistent with oligoovulation), a characterization of premenstrual molimina (breast tenderness, mood changes) presence of which is suggestive of ovulatory cycles, and information regarding any previous pregnancies and methods of contraception. Whereas women with PCOS typically report menstrual irregularity beginning at or soon after menarche, an abrupt departure from a previously established pattern of regular menses suggests another diagnosis. Although the clinical presentation of nonclassical CAH can closely resemble that of PCOS, hirsutism tends to present early in life and be more severe in women with CAH.<sup>67,68</sup> A later age at onset of hirsutism (after age 25) or rapid progression over a period of months are suggestive of an androgen-producing neoplasm. **It is important to correlate changes in menstrual pattern with changes in weight and to remember that previous hormonal contraception could have obscured or delayed the onset of symptoms of menstrual dysfunction or androgen excess.** Hirsutism in childhood usually is caused by classical CAH or an androgen-secreting tumor. Rare genetic causes of hirsutism, such as Y chromosome mosaicism or incomplete androgen insensitivity, usually present with signs of androgen excess at puberty ([Chapter 8](#)).

A **family history** of hirsutism, oligo/amenorrhea, obesity, and infertility are suggestive of a familial predisposition to PCOS, as well as should alert clinicians to consider nonclassical CAH as a differential diagnosis; the latter is more common in women with Hispanic, Mediterranean, Slavic, or Ashkenazi Jewish heritage.<sup>69</sup> Iatrogenic contributors to hair excess should also be considered. Drugs that can stimulate hair growth include methyltestosterone, anabolic steroids (e.g., norethandrolone), phenytoin, diazoxide, danazol, cyclosporine, and minoxidil. A variety of supplements are available over the counter containing DHEA or androstenedione, which can increase testosterone levels, and their use by women cause hirsutism and acne, even at relatively low doses. The hair growth caused by medications other than androgens is typically diffuse and vellus in nature (hypertrichosis). Recognizing that there are ethnic differences in hair density and texture, it is meaningful to enquire about whether the patient perceives herself as hairier than the remainder of female family members.

The **physical examination** should include a calculation of the body mass index

(BMI) and document the distribution and extent of hirsutism.<sup>70,71,72</sup> The modified **Ferriman-Gallwey (FG) score** is the most common method utilized for grading the presence and severity of hirsutism in clinical practice.<sup>73,74</sup> The modified FG method scores hair growth from 0 to 4 in each of 9 androgen-sensitive areas (the original version included 11 bodily areas, first described in 1961), including the upper lip, chin, chest, upper and lower abdomen, upper arm, thighs, and the upper and lower back; scale scores range from 0 to 36 and each point increase in site specific score reflects greater terminal hair density and involvement of greater affected body surface area (**Figure 12.7**).



**FIGURE 12.7**

## Modified Ferriman-Gallwey Scoring System for Hirsutism (Figure 12.7)

The originally described scoring method was based on studies undertaken in white women. Since its initial introduction in clinical practice, FG scoring system has been utilized to quantify hair excess in various ethnic populations, providing an understanding that ethnicity must be considered when categorizing threshold scores that differentiate normal from abnormal,<sup>75</sup> as both the number of hair follicles per unit skin area as well as rate of hair growth vary by ethnicity and race.<sup>76</sup> While there is no universally accepted cutoff score that defines hirsutism, a score  $\geq 8$  is generally used to define hirsutism in white and black women as approximately 95% will manifest a modified FG score less than 8; scores of 8–15 and greater than 15 are accepted to reflect mild to moderate and severe hirsutism, respectively. Given the recognized ethnic differences in hair growth, a higher FG score threshold has been suggested to define hirsutism in women of Mediterranean and Middle Eastern descent. In contrast, FG score as low as 3 is adequate for East Asian women (Chinese, Japanese, Thai, Korean) to be considered hirsute.<sup>72,77</sup> Notably, approximately 15% of women with scores less than 3 also consider themselves hirsute.

**There are no significant differences between white and black women with regard to the distribution of scores or the proportions that complain of hirsutism or use some method of hair removal.**<sup>78</sup> Taken together, these data indicate that it is quite normal for most women to have at least some hair growth in androgen-sensitive areas and that a score of 8 or higher reflects significant androgen excess that warrants evaluation. **Although the modified FG score is the accepted standard for clinical investigations involving hirsute women, it is difficult to use clinically, primarily because most women who seek medical attention for the complaint already are using one or more methods of hair removal. Moreover, the score is an unreliable indicator of hyperandrogenism for women in racial or ethnic groups having relatively little body hair (such as East Asian populations); although less likely to develop hirsutism, they can exhibit other signs of androgen excess, such as acne and thinning or loss of scalp hair. The easiest and most practical way to assess the severity of hirsutism is to determine the methods used to remove hair (e.g., shaving, plucking, waxing) and the frequency of their use, which also provides a clinically relevant measure for assessing the response to treatment.** Overall, approximately 25% women use some sort of cosmetic treatment for excess hair, such as bleaching, plucking, shaving, waxing, or electrolysis; the frequency of self-treatment correlates positively with the FG score.

The physical examination also should note other relevant skin manifestations as

well as any signs of virilization. Acne, seborrhea, and temporal balding are signs of androgen excess. Acanthosis nigricans (a gray or brown velvety discoloration of the skin, most commonly observed at the nape of the neck, groin, and axillae) indicates insulin resistance, and thin skin, broad pink-purple cutaneous striae, or easy bruising are signs of hypercortisolism. Frontal, temporal, or crown balding, deepening of the voice, increased muscle mass, breast atrophy, and clitoromegaly, are some signs of virilization. Normal clitoral size varies significantly among women<sup>79</sup>; in one study, the mean length of the glans clitoris was  $5.1 \pm 1.4$  mm and the mean width was  $3.4 \pm 1.0$  mm.<sup>80</sup> Clitoromegaly generally is defined by a clitoral glans longer than 10 mm or by a clitoral index (length times width) greater than  $35 \text{ mm}^2$ .<sup>81</sup> Other noteworthy physical findings include spontaneous or expressible galactorrhea, suggesting hyperprolactinemia, and abdominal or pelvic masses that may represent an androgen-secreting tumor. The large majority of functional ovarian tumors are palpable in women of normal body mass.

The physical manifestations of androgen excess generally reflect the extent to which androgen levels are elevated. Hirsutism is the most common complaint associated with androgen excess, and essentially all women with hirsutism have an increased production rate of testosterone and androstendione<sup>82</sup>; however, hirsutism can be seen in the presence of normal circulating androgen levels.<sup>8</sup> Worsening acne, increased libido, clitoromegaly, and virilization reflect progressively higher serum androgen levels.

**Scalp hair thinning or Alopecia** is an uncommon symptom of androgen excess that often is a cause of significant stress for the patient and is a vexing problem for the clinician. In many cases, alopecia is only temporary, resulting from telogen effluvium induced by some transient change that synchronizes a larger than normal proportion of scalp hair follicles, such as pregnancy or a febrile illness, and resolves after a period of 6–8 months. In a series of 109 consecutive women presenting with a complaint of diffuse alopecia, two thirds had no clinical evidence of hirsutism or menstrual dysfunction, two had nonclassical CAH, and two had hyperprolactinemia associated with a pituitary adenoma.<sup>83</sup> Of the 42 (38.5%) that had elevated serum androgens, 11 were ovulatory and not hirsute, 13 were ovulatory and hirsute, and 18 had both oligomenorrhea or amenorrhea and hirsutism.<sup>83</sup> While hair loss can be a normal consequence of aging, beginning in both sexes around the age of 50 years,<sup>84</sup> women with complaints of alopecia deserve evaluation for hyperandrogenism, as well as thyroid disorders (serum TSH) and chronic illness. Because alopecia can reflect increased scalp  $5\alpha$ -reductase activity, normal circulating androgen levels do not necessarily preclude effective treatment.<sup>85,86</sup> More than half (up to 60%) of women with acne and normal serum androgen concentrations exhibit evidence of increased peripheral  $5\alpha$ -reductase activity and may benefit from treatment for hyperandrogenism.<sup>87</sup> Some degree



of benefit for scalp hair can be anticipated with use of antiandrogen therapy in those where an up-regulation of scalp  $5\alpha$ -reductase activity is the underlying mechanism.

# LABORATORY EVALUATION

---

The relationship between hirsutism and circulating androgen concentrations is not entirely clear. Whereas some studies have found a correlation between hirsutism and androgen levels,<sup>88</sup> others have observed that only 50% of women with mild hirsutism have elevated free testosterone levels and that almost a third with moderately elevated free testosterone concentrations have no hirsutism.<sup>89</sup> These observations suggest that factors other than circulating androgen levels (such as insulin, individual variations in 5 $\alpha$ -reductase activity and in androgen sensitivity) have substantial influence on the development and severity of hirsutism. In a cross-sectional study of self-reported hair loss in women with PCOS, metabolic abnormalities including abnormalities of glucose homeostasis and dyslipidemia were significantly more prevalent in women acknowledging thinning of scalp hair.<sup>90</sup>

**Laboratory evaluation is indicated for many but not all women with hirsutism.<sup>91</sup>** The primary aim is to identify those having potentially serious endocrine disorders requiring specific treatment (such as nonclassical CAH, androgen-secreting tumors, Cushing syndrome). Thyroid disorders and hyperprolactinemia should be considered and excluded, particularly in women with menstrual dysfunction. **Laboratory evaluation is recommended for women with moderate or severe hirsutism, or hirsutism that is sudden in onset, rapidly progressive, or associated with symptoms or signs of virilization.<sup>92</sup>** Routine laboratory evaluation of women with isolated mild hirsutism is neither necessary nor cost-effective. In women with oligo/amenorrhea, mild hirsutism can be attributed confidently to increased ovarian androgen production resulting from chronic anovulation. In women with regular menses, hirsutism is most likely idiopathic, with increased sensitivity of PSUs to androgens as well as excessive peripheral 5 $\alpha$ -reductase activity as plausible underlying mechanisms.

**The serum total testosterone concentration provides the best overall measure of androgen production. Testing for nonclassical CAH is of highest yield for patients with an early onset of hirsutism (pre- or perimenarcheal onset, including those with premature adrenarche), women with a family history of the disorder, and those in high-risk ethnic groups (Hispanic, Mediterranean, Slavic, or Ashkenazi Jewish heritage); see Chapter 13 for a thorough discussion of such testing. The serum DHEA-S concentration can be grossly elevated ( $\geq 700$   $\mu\text{g/dL}$ ) in women with rare androgen-secreting adrenal tumors. However, as discussed in Chapter 13, serum testosterone levels also are greatly elevated in almost all such patients,<sup>93</sup> so the test has little or no clinical utility in the evaluation of hirsutism.**

# Serum Testosterone Concentration

Serum testosterone levels (normal 20–80 ng/dL) are elevated in most (70%), but not all, women with chronic anovulation and hirsutism. The total testosterone concentration can be normal in hirsute women because SHBG levels are depressed by androgen and insulin, thereby increasing the amount of unbound or free testosterone. Indeed, free testosterone levels are approximately twice normal (an increase from 1% to 2%) in women with PCOS.<sup>94</sup>

**Laboratory testing for elevated androgen levels should begin with a serum total testosterone concentration.** Total testosterone assays measure free testosterone, albumin-bound testosterone, and testosterone bound to SHBG. Although the free testosterone level is a more sensitive indicator of androgen excess, direct immunoassays of free testosterone are inaccurate,<sup>95</sup> yielding values only 20–60% of those measured by other, more precise methods.<sup>96,97</sup> The best method for measuring the free testosterone level is equilibrium dialysis, a method only offered by select laboratories.<sup>95</sup> In fact, surveys suggest that over 80% of U.S. clinical laboratories send free testosterone measurements to centralized reference labs.<sup>98</sup> The free testosterone concentration also can be calculated using equations derived from the laws of mass action, knowing the serum total testosterone, SHBG, and albumin concentrations, and the association constants for the interactions of testosterone with SHBG and albumin.<sup>99,100</sup> Calculated values generally correlate well with those determined by equilibrium dialysis, although accuracy varies with the specific assays used to measure total testosterone and SHBG. However, measurement or calculation of the free testosterone level generally is useful only in patients who have worsening hirsutism despite active treatment and normal total testosterone levels. **Total testosterone is most reliably evaluated in the early morning during the follicular phase for women with normal menstrual cycles. When undertaking testing in the setting of prolonged oligomenorrhea or amenorrhea, concomitant measurement of gonadotropins as well as estradiol and progesterone levels can allow reliable interpretation of hormone profile as a rise in total testosterone levels in the periovulatory period is quite normal.**

**A serum total testosterone concentration greater than 150 ng/dL identifies almost all women with a possible androgen-producing tumor.**<sup>35,51,52,54,101,102</sup> However, because serum testosterone concentrations can vary significantly in women with and without tumors,<sup>52</sup> a tumor still should be suspected, and excluded, in women with rapidly progressive hirsutism or signs or symptoms of virilization, even when the serum testosterone concentration is below the tumor threshold value. Nearly all women with PCOS have a testosterone level less than 150 ng/dL, as

do all women with IH, by definition. The suggested threshold value of 150 ng/dL has very high sensitivity and negative predictive value, indicating that it captures virtually all women with tumors as well as can effectively exclude this diagnosis.<sup>102</sup> The positive predictive value of a serum total testosterone level greater than 150 ng/dL, however, is quite low, indicating that only a few women demonstrating this degree of hyperandrogenemia will, in fact, have an androgen-secreting tumor, primarily because such tumors are very rare and the large majority will have PCOS or hyperthecosis. Taken together, the clinical history (age at onset, rate of progression of hirsutism, other symptoms of hyperandrogenism such as acne and hair loss), physical examination (severity of hirsutism, alopecia, signs of virilization, pelvic masses), and the serum total testosterone concentration will identify women with androgen-producing tumors.

It also is important to remember that testosterone levels are elevated significantly during normal pregnancy. Concentrations are greater than 100 ng/dL during the first trimester and can reach 500–800 ng/dL by term,<sup>103</sup> primarily due to the estrogen-induced increase in SHBG. Mother and fetus normally are protected from virilization because free testosterone levels rise only modestly and are rapidly converted to estrogen via placental aromatization. Because testosterone levels normally are lower in postmenopausal women, concentrations greater than 100 ng/dL should raise suspicion for a tumor.

## **Serum DHEA-S Concentration**

DHEA-S derives almost exclusively from the adrenal gland and is a direct measure of adrenal androgen activity. DHEA-S serves primarily as a prehormone, providing substrate for conversion to testosterone and DHT in the periphery.<sup>104</sup> **In evaluation of hirsutism, serum DHEA-S concentrations may offer guidance in identifying women with adrenal causes of hyperandrogenism. The serum DHEA-S concentration is moderately elevated in over half of women with PCOS.<sup>105</sup> Persistent elevation in serum DHEAS levels in the setting of hirsutism should also raise concerns regarding possibility of nonclassical CAH due to 3 $\beta$ -hydroxysteroid dehydrogenase deficiency.<sup>106,107</sup> The serum DHEA-S concentration can be grossly elevated ( $\geq 700$   $\mu\text{g/dL}$ ) in women with rare androgen-secreting adrenal tumors. However, in almost all such patients, serum testosterone levels also are greatly elevated,<sup>93</sup> via peripheral conversion of high circulating DHEA-S levels, or because the tumor also secretes testosterone. A serum DHEA-S concentration may be useful in women whose clinical presentation suggests strongly the possibility of a tumor, but the test otherwise has little or no clinical utility in the evaluation of hirsutism.**

# Evaluation for a Suspected Androgen-Producing Tumor

When the serum total testosterone concentration ( $>150$  ng/dL) or the clinical presentation (e.g., rapidly progressive hirsutism or symptoms or signs of virilization) suggests the possibility of a rare androgen-producing ovarian or adrenal tumor, evaluation is indicated to exclude the diagnosis or localize the lesion.

Androgen-secreting tumors of the ovary (in decreasing order of prevalence) include Sertoli-Leydig tumors, lipid cell tumors, hilar cell tumors, and rare androgen-producing theca cell and Brenner tumors; virtually all are associated with grossly elevated serum total testosterone levels ( $>150$  ng/dL). Occasionally, virilization results from a nonfunctioning ovarian tumor that creates a mass effect with resulting stimulation of the surrounding stroma.<sup>108</sup> Most functioning ovarian tumors are palpable on pelvic examination, but small tumors easily can go unrecognized, particularly in the overweight to obese women. **Transvaginal ultrasonography** can identify almost all solid ovarian mass lesions, although very small tumors located in the hilar region still can escape detection. Imaging approaches for detecting the rare androgen-producing adrenal adenoma or carcinoma, as reviewed in [Chapter 13](#), should be considered when in the setting of clinical suspicion, pelvic examination and transvaginal ultrasonography fail to reveal an ovarian tumor.<sup>109</sup> **Selective ovarian venous catheterization** can be considered for the rare patient having no demonstrable ovarian or adrenal mass lesion.<sup>53,101,110,111,112</sup> **However, because the overall clinical utility of the technique is still uncertain,<sup>113</sup> the procedure should be reserved only for women desiring future fertility (and thus desiring to avoid bilateral oophorectomy) in whom an ovarian androgen-secreting tumor is strongly suspected despite negative imaging.** An analysis of results obtained in 136 reported patients with hirsutism who had selective ovarian venous sampling yielded a number of important observations.<sup>113</sup> A right:left ovarian venous effluent testosterone ratio greater than 1.44 correctly identified 90% of right-sided tumors and lower values correctly identified 86% of women with left-sided or bilateral lesions. In three women with a left-sided tumor, the left:right testosterone ratio was greater than 15. The differing anatomy of the right (draining into the vena cava) and left ovarian vein (draining into the left renal vein) and the related technical difficulty of catheterization might explain why venous sampling was more effective for identifying right-sided ovarian tumors.

When suspicion for a tumor is insufficient to warrant ovarian venous catheterization, or the procedure reveals no significant gradient in testosterone concentrations, the likelihood of an occult ovarian tumor is very small, leaving the HAIR-AN syndrome or stromal hyperthecosis as the most likely cause of severe

hyperandrogenism. Both are associated with severe insulin resistance, which can be documented by performing an **oral glucose tolerance test including insulin levels**, as discussed below. The likelihood of an informative yield from open surgical exploration of the ovaries in the setting of negative imaging is slim; however, in resource poor settings, this may be necessary to establish a diagnosis; laparoscopic inspection and biopsy are not sufficient.

Dynamic endocrine evaluation, using dexamethasone, contraceptive steroids, or a GnRH agonist in attempts to isolate adrenal or ovarian androgen production, is not recommended, because results are unreliable and can be misleading.<sup>108,114,115,116</sup>

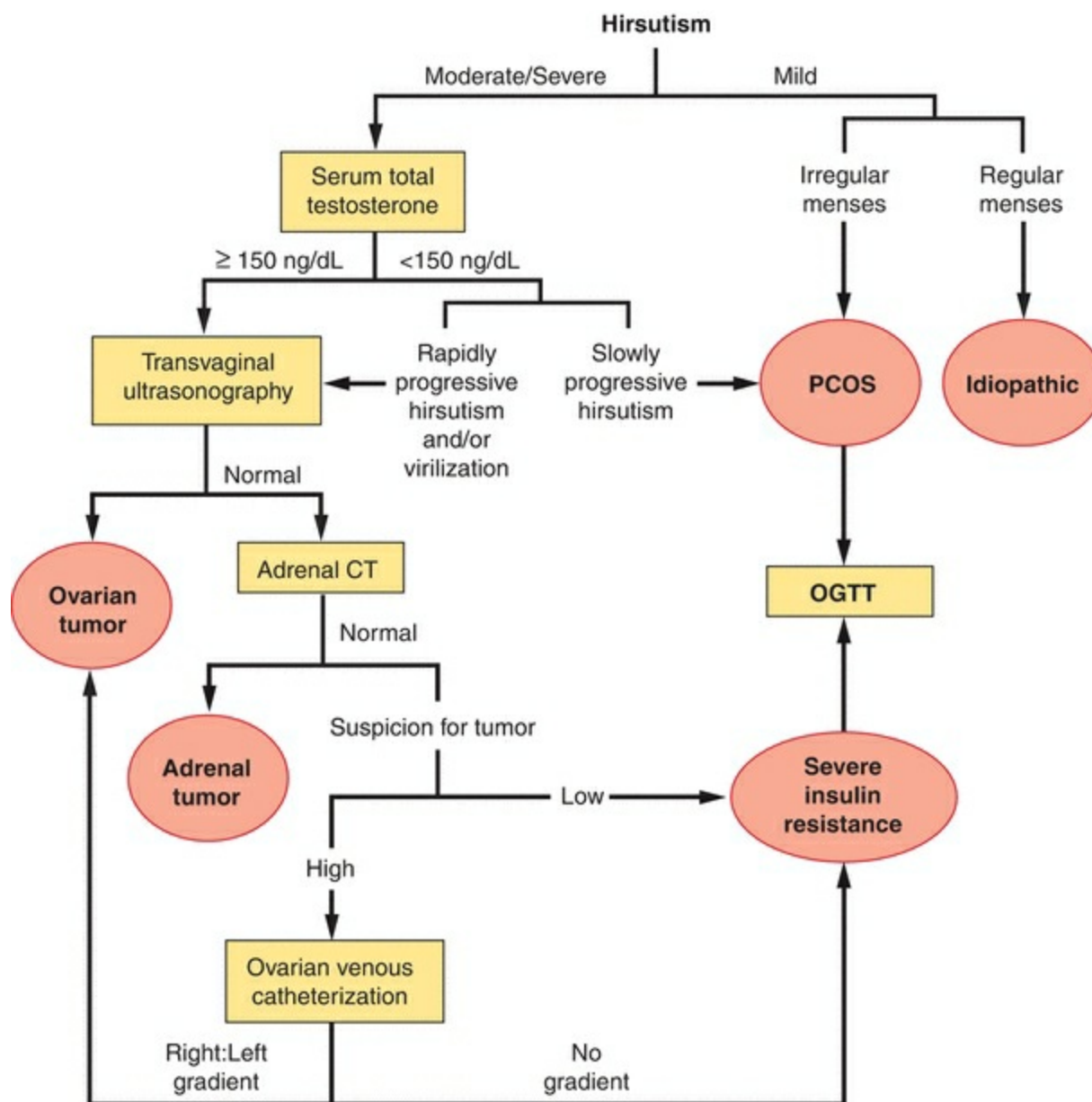
**Ovarian androgen-secreting tumors are sensitive to LH stimulation and thus respond to ovarian suppression and stimulation.**<sup>117,118,119</sup>

# Insulin Resistance

Insulin resistance is a common feature of women with PCOS and a key component of the HAIR-AN syndrome and ovarian stromal hyperthecosis. **Although high circulating androgen concentrations decrease insulin sensitivity, the primary pathology in women with HAIR-AN and hyperthecosis is severe insulin resistance, resulting in grossly elevated insulin levels that stimulate ovarian androgen production in theca cells (via insulin, IGF-1, and hybrid receptors) and markedly decrease hepatic SHBG production, thereby greatly increasing the amount of circulating free androgen.** Insulin resistance and hyperinsulinemia also explain the occasional elderly woman who presents with severe progressive hirsutism and elevated total testosterone levels. The problem does not simply reflect an ovarian response to elevated pituitary gonadotropin levels but actually relates to the development of hyperinsulinemia-driven hyperthecosis. Insulin appears to have a direct effect on the severity of hirsutism and a synergistic interaction with testosterone.<sup>120</sup> A number of methods have been described to quantify both insulin sensitivity and insulin resistance and are further discussed in [Chapter 11](#). Evidence of acanthosis nigricans is a reliable clinical indicator of significant insulin resistance.

**A baseline 2-hour oral glucose tolerance test (75-g glucose load) is recommended for all women with PCOS,<sup>33,121,122</sup> because up to 35% exhibit impaired glucose tolerance (glucose 140–199 mg/dL) and up to 10% have non-insulin-dependent diabetes mellitus (glucose  $\geq$ 200 mg/dL).<sup>123</sup>** In patients with severe hyperandrogenism having no evidence of an androgen-secreting tumor, the corresponding fasting and 2-hour insulin concentrations can be used to document the degree of insulin resistance, in support of the diagnosis of HAIR-AN syndrome or hyperthecosis; most have grossly elevated insulin levels.<sup>40</sup> The 2-hour glucose/insulin ratio (mg/dL/ $\mu$ U/mL) provides an estimate of insulin sensitivity, with values less than 1.0 indicating insulin resistance. Plasma insulin concentrations that exceed an upper limit of normal or a defined threshold value (e.g., a 2-hour plasma insulin  $>$ 80–100  $\mu$ U/mL) also have been used as a quantitative test for insulin resistance ([Figure 12.8](#)).





**FIGURE 12.8**

Although the use of insulin-sensitizing agents in women with PCOS has been associated with improvements in circulating androgen levels, any evidence that such an approach offers benefit against hirsutism is lacking and treatment with insulin-sensitizing agents specifically for hirsutism (i.e., in the absence of menstrual or metabolic abnormalities) is likely of minimal value.<sup>124</sup> **Consequently, routine assessment of insulin sensitivity in the evaluation of isolated hirsutism is not recommended.**

## Key Points: Evaluation of Hirsutism

- Laboratory evaluation is recommended for women with moderate or severe hirsutism, or hirsutism that is sudden in onset, rapidly progressive, or associated with symptoms or signs of virilization. Routine laboratory evaluation of women with mild hirsutism is unnecessary.
- The serum total testosterone concentration is the best overall measure of androgen production and is the first hormone that should be measured in women with hirsutism that merit evaluation.
- An androgen-secreting tumor should be suspected, and excluded, in women with rapidly progressive hirsutism, symptoms or signs of virilization, or a serum testosterone concentration 150 ng/dL or greater. However, most such patients will not have a tumor.
- Nonclassical congenital adrenal hyperplasia should be suspected, and excluded, in patients with an early onset of hirsutism (pre- or perimenarcheal, including those with a premature adrenarche), in women with a family history of the disorder, and those in high-risk ethnic groups (Hispanic, Mediterranean, Slavic, and Ashkenazi Jewish heritage).
- Cushing syndrome should be suspected, and excluded, in hirsute women manifesting symptoms and signs of hypercortisolism (discussed in [Chapter 13](#)). Coexistence of hypertension and diabetes in women with hirsutism should prompt consideration for screening for Cushing syndrome.

# TREATMENT OF HIRSUTISM

---

The treatment of hirsutism should be directed toward its cause, whenever possible, but also must consider the extent to which the patient views it as a problem, and her therapeutic and reproductive goals. Whereas laboratory evaluation is recommended only for women with moderate or severe hirsutism, treatment should be considered for all women who judge themselves hirsute. Excess facial and bodily hair can be a source of significant psychological stress, and many with mild hirsutism often seek treatment.<sup>78</sup>

Although hirsutism can be managed using cosmetic measures such as shaving, plucking, waxing, and depilatory agents, most women with hirsutism have increased androgen production, and hair growth promptly recurs if managed only by physical removal; most already are using one or more such methods. Consequently, almost all who seek treatment for hirsutism require and will benefit from pharmacologic therapy.

The severity of hirsutism should be defined before treatment begins to provide the means for monitoring response; the methods and frequency of hair removal provide the most practical and clinically relevant measure of treatment efficacy. **Serial measurements of serum androgen levels during treatment are neither necessary nor helpful. However, repeated hormonal evaluation is indicated when hirsutism progresses despite treatment.**

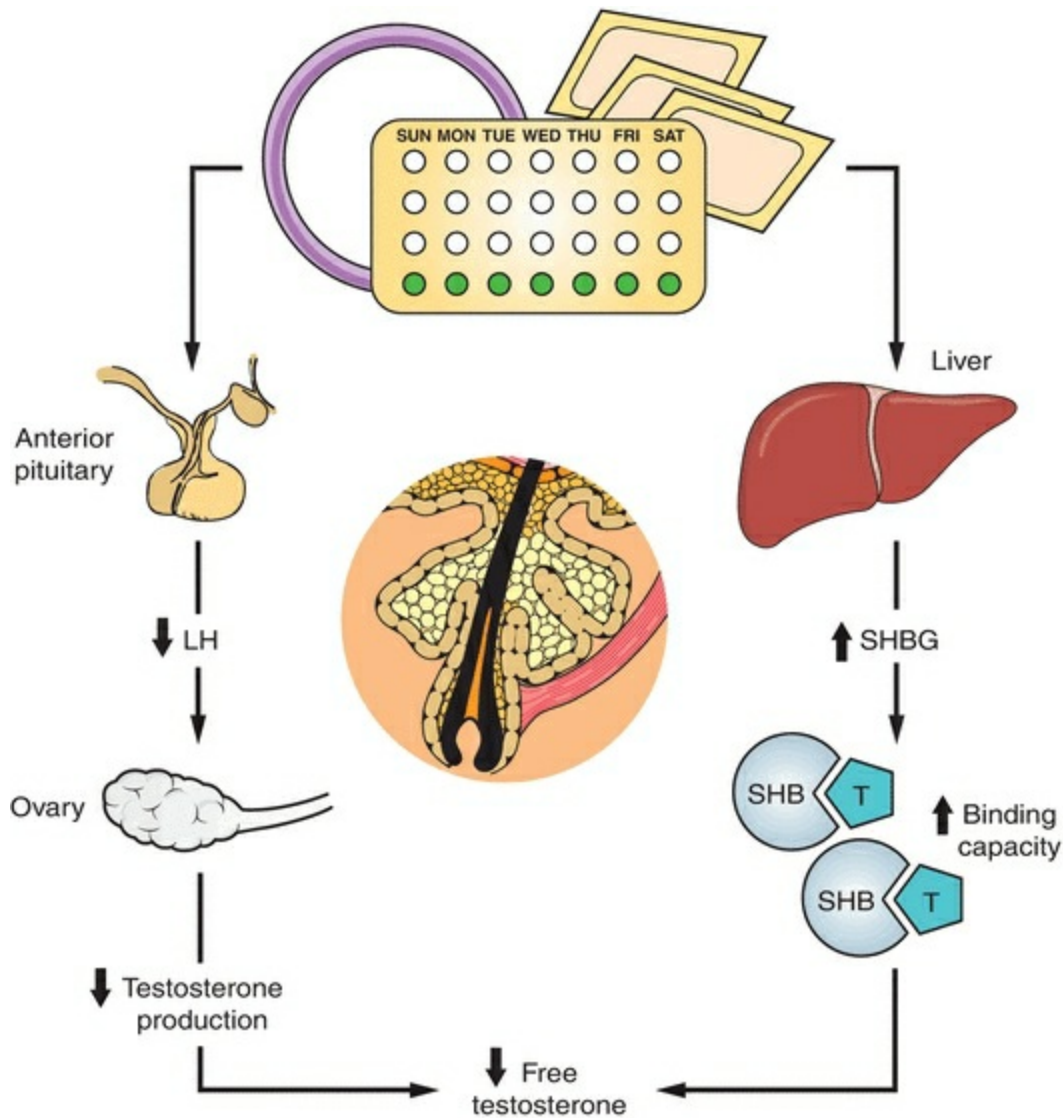
Before treatment begins, it also is important to foster reasonable expectations regarding its likely impact as well as timeline for anticipated benefit. Finer, lighter, and slower hair growth, and the prevention of new terminal hair growth, all can be expected; a complete cessation or elimination of hair growth however cannot. **No significant reduction in hair growth may occur for up to 6 months, which approximates the half-life of a hair follicle growth cycle.** After 6 months, a change in dose or drug, or the addition of a second drug, should be considered if the patient judges her response as inadequate. In general, treatment, once initiated, should be continued indefinitely or until the time that the patient is ready to pursue fertility because the problem of hair excess rarely goes away and almost always recurs following treatment discontinuation.<sup>125</sup> Almost all treatment options that are available for management of hirsutism either actively prevent the possibility of conception (such as hormonal contraceptive formulations) or are contraindicated for use in pregnancy (such as antiandrogens that due to known and potential teratogenic effects as in utero exposure of male fetus to antiandrogens can interfere with the normal development of male external genitalia).

Treatments for hirsutism are aimed at reducing the production, increasing the protein-bound proportion, and/or blocking the action of androgens. Combined estrogen-progestin hormonal contraceptives and antiandrogens are the primary weapons in the

therapeutic arsenal against hirsutism. It is important to emphasize that even women with IH relating to increased end-organ sensitivity to androgens can benefit from treatments that lower free/active androgen concentrations or block the androgen receptor<sup>126</sup>; clinical response correlates with circulating levels of 3 $\alpha$ -androstane-20-one glucuronide (the peripheral metabolite of DHT), supporting increased peripheral 5 $\alpha$ -reductase activity as the cause of IH.<sup>127</sup>

# Estrogen–Progestin Hormonal Contraceptives

Estrogen–progestin contraceptives have a number of complementary noncontraceptive actions that make them a logical and effective treatment for hirsutism ([Figure 12.9](#)):



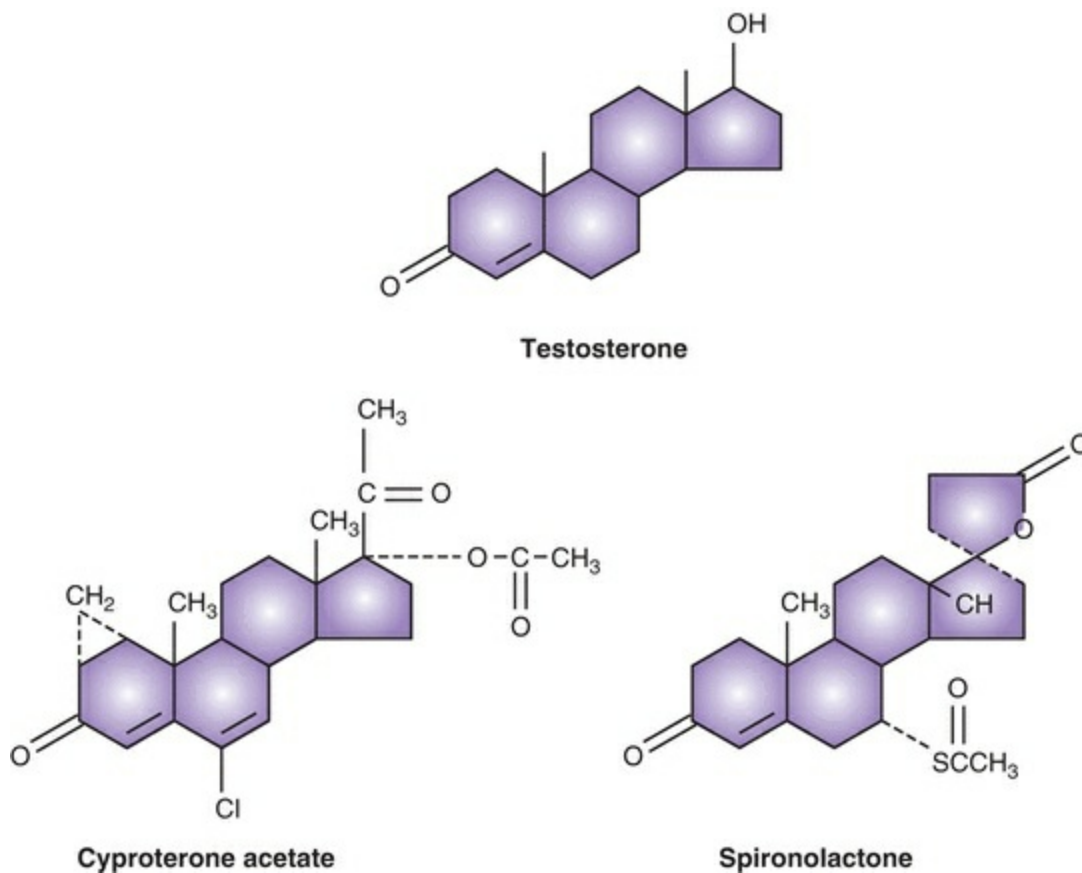
**FIGURE 12.9**

## Key Points: Estrogen–Progestin Hormonal Contraceptives

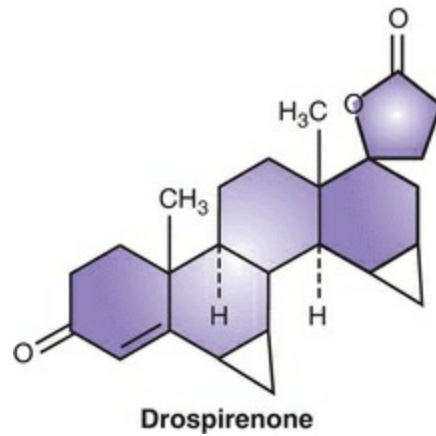
- In hirsute women, ovarian androgen production usually is an LH-dependent process. The progestin component of the combination estrogen–progestin

contraceptives, through negative feedback, suppresses pituitary LH secretion and thereby also suppresses ovarian androgen production.<sup>128,129,130,131</sup>

- The high level of estrogen component in combination contraceptives stimulates hepatic SHBG production, thereby increasing binding capacity for circulating androgens and decreasing the amount of free/active androgen.<sup>131,132,133</sup>
- Directly or indirectly, combination estrogen–progestin contraceptives can also decrease adrenal DHEA-S secretion to variable degrees.<sup>134,135,136,137</sup>
- Certain synthetic progestogens (19-nor-derivatives such as levonorgestrel and norethindrone) in high doses can inhibit  $5\alpha$ -reductase activity in the skin,<sup>138</sup> which decreases the production of dihydrotestosterone (DHT), the major nuclear androgen in hair follicles and sebaceous glands. Others, such as cyproterone acetate (**Figure 12.10**) and drospirenone (**Figure 12.11**), inhibit androgen signaling at the level of the androgen receptor, thereby acting as antiandrogens.<sup>139,140,141,142</sup>



**FIGURE 12.10**



**FIGURE 12.11**

The large majority of the benefits resulting from treatment with estrogen–progestin contraceptives derive from the first two actions. In addition to these specific actions on androgen production, binding, and metabolism, combination contraceptives have other effects that often are equally important in the clinical management of women with hirsutism. Most women with hirsutism have underlying chronic anovulation and menstrual irregularity as well as episodic dysfunctional bleeding is often encountered in this population. Combinations of chronic anovulation and insulin resistance often predispose to abnormal patterns of endometrial growth. Treatment with estrogen–progestin contraceptives addresses not just the mechanisms underlying hirsutism but additionally offers endometrial protection due to continuous progestin exposure, thereby mitigating risk for developing endometrial pathology including hyperplasia and even cancer. The predictability of the induced withdrawal bleeding, lessening in volume and duration of menstrual flow, and thereby improved menstrual discomfort as well as reliable contraceptive efficacy are additional benefits that make combination estrogen–progestin contraceptive formulations as a first-line approach for managing hirsutism.

Current oral contraceptives contain ethinyl estradiol, in doses ranging from 20 to 50  $\mu\text{g}$  daily, and one of a variety of progestins. **In general, all low-dose oral contraceptives (containing 20–35  $\mu\text{g}$  ethinyl estradiol) have similar effectiveness in the treatment of acne and hirsutism.** Although estrogen induces a dose-dependent increase in serum SHBG concentrations,<sup>131,132</sup> low- and higher-dose pills suppress free testosterone levels to a comparable extent.<sup>143,144</sup> Although contraceptive progestins have varying impact on SHBG levels, most studies show no detectable differences in their overall clinical effectiveness.<sup>143,144,145,146,147</sup> **Notable, however, are a few studies that demonstrate superiority against symptoms of hyperandrogenism of formulations containing antiandrogenic progestins.**<sup>139,141</sup> Cyproterone acetate (CPA, [Figure 12.10](#)) is an antiandrogenic progestin that has long been available in combination with ethinyl

estradiol as oral contraceptive formulations in many countries; these, however, remain absent from the U.S. market. CPA has been shown to cause greater improvement to hirsutism (as measured by the modified FG score) than other contraceptive progestins after 12 months of use.<sup>139</sup> Drospirenone (**Figure 12.11**), a derivative of spironolactone, is a newer progestin that has some intrinsic antiandrogenic properties.<sup>148,149</sup> The dose of drospirenone utilized in contraceptive formulations (3 mg) is equivalent to approximately 25 mg spironolactone,<sup>92</sup> and although this low dose was considered ineffective in providing additive benefit beyond that already offered by the estrogen component of contraceptive formulations,<sup>139,150</sup> recent data demonstrate superiority of drospirenone-containing contraceptives against hyperandrogenism compared to formulations containing other progestins.<sup>141</sup> Yet another consideration that relates to the progestin component of a hormonal contraceptive formulation is that of androgenic potential. Progestins that are 19-nortestosterone derivatives (such as levonorgestrel, norethindrone), while being potent in their progestogenic effects, are innately androgenic and can theoretically worsen symptoms of hyperandrogenism, specifically acne.<sup>147,151</sup> **Although the evidence is limited that levonorgestrel-containing contraceptive formulations are less effective for hirsutism, it is prudent to preferentially choose contraceptive formulations containing less androgenic or even antiandrogenic progestin to manage hirsutism, particularly so when acne is also present.**

The transdermal contraceptive patch (delivering 20 µg ethinyl estradiol and 150 µg norelgestromin daily) and the vaginal contraceptive ring (releasing 15 µg ethinyl estradiol and 120 µg etonogestrel daily) are effective hormonal contraceptives. The average circulating ethinyl estradiol concentration in transdermal hormonal contraceptive patch users is approximately 60% higher than in women using an oral contraceptive containing 35 µg ethinyl estradiol, resulting in a greater increase in SHBG and thus a probability of greater benefit against hyperandrogenism; however, the overall decrease in androgen levels is no different from oral formulations.<sup>152</sup> Data regarding effects of transdermal and vaginal estrogen–progestin hormonal contraceptive formulations on hirsutism are nonexistent.

The progestin-only contraceptive formulations, and in particular higher-dose progestin regimens, such as medroxyprogesterone acetate 10–20 mg orally daily, or 150 mg intramuscularly every 3 months, may be considered in women with evidence of hyperandrogenemia in the setting of elevated LH levels for whom use of estrogen–progestin combination formulations is contraindicated. Although the progestin-alone regimen suppresses gonadotropins secretion to a lesser extent than estrogen–progestin regimens, LH still is suppressed sufficiently to cause a significant decrease in ovarian androgen production. In addition, testosterone clearance increases during treatment with



medroxyprogesterone acetate,<sup>153</sup> due to induction of hepatic enzyme activity. Although SHBG levels are decreased during treatment, the decrease in androgen production is so great that free testosterone levels still are decreased overall.<sup>154</sup>

Subjectively, 60–100% of women report improvement in their hirsutism during treatment with oral contraceptives,<sup>128,129,130,131,155</sup> which agrees with observations in studies using objective measures of hirsutism.<sup>131,132,155,156,157</sup> Combination oral contraceptives have similar effectiveness for improving acne and seborrhea.<sup>158,159</sup> Clinical improvement reflects the decrease in free/active androgen during treatment: new terminal hair growth decreases or stops, terminal hairs already present grow more slowly and produce finer hair, and acne gradually improves or disappears. **Hormone therapy must be continued for at least 6 months before judging its effectiveness.** In the meantime, the patient can continue to use her preferred method of hair removal (e.g., shaving, plucking, waxing). After 1–2 years, or when pregnancy becomes the goal, treatment can be discontinued and the patient observed for a return of ovulatory cycles, although most again will exhibit chronic anovulation. **Permanent hair removal by electrolysis or laser methods (discussed below) may be required ultimately, at least in some patients, but is best postponed until hormonal suppression has achieved its maximum benefits.**

# Antiandrogens

**Antiandrogens are an effective treatment for hirsutism but are best used in combination with hormonal contraceptives or another means of highly effective contraception because they have the potential to adversely affect sexual development in a genetic male fetus if the patient conceives during treatment.** In patients with contraindications to combined hormonal contraceptives, an alternative means of reliable contraception (e.g., an intrauterine device) should be provided during treatment with antiandrogens. Combination of hormonal contraceptives and antiandrogens also is a logical choice for patients who respond inadequately to contraceptives alone.

## Spironolactone

Spironolactone is an aldosterone antagonist having structural similarity to progestins that predominantly acts as an androgen receptor antagonist (**Figure 12.10**). Spironolactone competes with DHT for binding to the androgen receptor and, to varying extent, also inhibits ovarian and adrenal androgen synthesis.<sup>160</sup> Although serum androstenedione levels decrease, those of DHEA, DHEA-S, and cortisol do not significantly change during treatment with spironolactone.

The effects of spironolactone are dose dependent, and best results are achieved with doses of 50–100 mg twice daily.<sup>161,162,163,164</sup> In two clinical trials comparing spironolactone (100 mg daily) with placebo, active treatment resulted in significantly greater subjective improvement in hirsutism.<sup>165,166</sup> As with all treatments for hirsutism, maximal effects are observed only after approximately 6 months of therapy. Side effects are relatively few, including diuresis in the early days of treatment and occasional complaints of fatigue and abnormal uterine bleeding. Although spironolactone can cause hyperkalemia, the effect is rare and monitoring of potassium levels is not necessary in women with normal renal function.

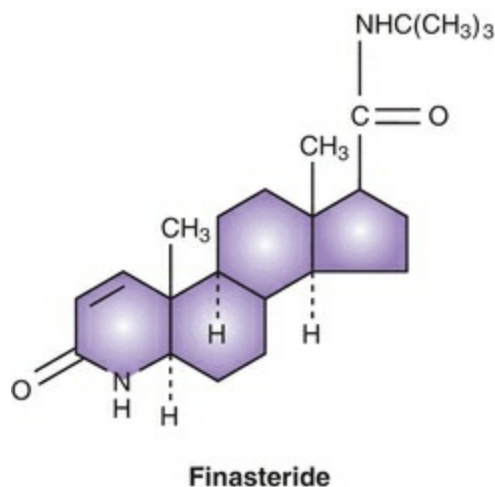
The action of spironolactone, peripheral androgen receptor blockade, nicely complements the androgen lowering effects of combined oral contraceptives and may thus provide additional benefit for those who fail to achieve adequate results from oral contraceptives alone. Although the results achieved with combined treatment are not greatly different from monotherapy,<sup>167,168,169</sup> the predominant benefits of the combined approach include reliable contraception and avoidance of erratic uterine bleeding that can be encountered with use of spironolactone alone. The abnormal bleeding pattern associated with spironolactone use can often be avoided by deferring spironolactone until after implementation of a hormonal contraceptive (e.g., by the addition of spironolactone as a second agent after 6 months of oral contraceptive use).

## Cyproterone Acetate

Cyproterone is a derivative of  $17\alpha$ -hydroxyprogesterone (17OHP) having potent progestational activity that inhibits gonadotropin secretion but also acts as a competitive androgen receptor antagonist and inhibits enzymes involved in androgen synthesis, like spironolactone (**Figure 12.10**). Cyproterone acetate is the progestin in the combined estrogen–progestin oral contraceptive called “Diane” (2 mg CPA and 50  $\mu$ g ethinyl estradiol) in common use in many parts of the world but not available in the United States. The lesser estrogen dose formulation “Dianette” or “Diane 35” contains 2 mg CPA and 35  $\mu$ g ethinyl estradiol. The drug also has been used in higher doses (12.5–100 mg), alone or in combination with estrogen.<sup>170,171</sup> A systematic review including data from nine clinical trials concluded that combined treatment with CPA and ethinyl estradiol is more effective than placebo and yields results comparable to those achieved with oral contraceptives, spironolactone, and other treatments.<sup>172</sup> The most common side effects associated with cyproterone treatment are fatigue, edema, loss of libido, weight gain, and mastalgia.

## Finasteride

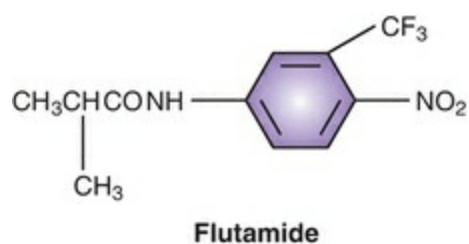
Finasteride inhibits  $5\alpha$ -reductase and thus blocks the conversion of testosterone to the more androgenic DHT. The enzyme  $5\alpha$ -reductase exists in two forms, with type 1 being most prevalent in the skin and type 2 predominating in reproductive tissues.<sup>173</sup> Although finasteride inhibits the type 1 enzyme only to a limited extent, evidence from clinical trials indicates its efficacy is comparable to those of spironolactone and another antiandrogen, flutamide.<sup>166,169,174</sup> Because fetal external male genital development requires the action of DHT, the risks of inadvertent finasteride treatment during pregnancy are a particular concern, and finasteride should not be used without a highly effective method of contraception (**Figure 12.12**).



## FIGURE 12.12

### Flutamide

Flutamide is a nonsteroidal androgen receptor antagonist used primarily in the treatment of prostate cancer. The drug (250–750 mg daily) inhibits hair growth directly and is as effective as spironolactone,<sup>157,166,169,175,176</sup> but its higher cost and potential for causing severe hepatotoxicity make it an unattractive therapeutic choice, by comparison<sup>177,178</sup> (Figure 12.13).



## FIGURE 12.13

In the absence of significant clinical benefit, combination of two different antiandrogen regimens (such as combining spironolactone and finasteride) has also been reported to offer benefit.<sup>179,180</sup>

# Insulin-Sensitizing Drugs

Given that PCOS is the most common cause of hirsutism and that insulin resistance is a common feature of the disorder, insulin-sensitizing drugs offer another potential approach to the treatment of hirsutism.<sup>92,181</sup> Treatment with metformin and thiazolidinediones (rosiglitazone, pioglitazone) decreases both circulating insulin and androgen levels in women with PCOS.<sup>182,183,184,185,186,187,188,189</sup> Improvements in hirsutism scores with use of metformin alone are described in the pediatric population.<sup>190</sup> However, a systematic review and meta-analysis including nine placebo-controlled trials concluded that insulin-sensitizing drugs have no important benefits for the treatment of hirsutism.<sup>124</sup> Accordingly, guidelines issued by the Endocrine Society suggest against their use for the treatment of hirsutism.<sup>92</sup>

## Other Treatments

The mainstay of medical treatment for hirsutism has been, and remains, estrogen–progestin contraceptives, with the addition of an antiandrogen as a second-line strategy, often introduced approximately 6 months after initiating trial of combination hormonal contraceptives if the desired cosmetic result has not yet been achieved. However, for women who are significantly bothered by symptoms of hyperandrogenism, and for those interested in use of levonorgestrel-containing intrauterine system, antiandrogen regimen can be initiated earlier and even concomitantly with contraceptive regimen.

## Gonadotropin-Releasing Hormone Agonists

In women with severe hyperandrogenism who fail to respond to or cannot tolerate treatment with estrogen–progestin contraceptives and antiandrogens, and particularly in those with evidence of LH dominance, GnRH agonist therapy can be considered. The effectiveness of GnRH agonist therapy relates directly to the suppression of LH-dependent ovarian androgen production. GnRH agonists (e.g., leuprolide, nafarelin, goserelin) are not recommended for routine use, primarily because they induce a severe hypoestrogenism but also because they are more costly and inconvenient to use.<sup>92</sup>

Serum androgen levels decrease dramatically during GnRH agonist treatment, typically falling to near-castrate levels within as little as a month.<sup>191,192,193,194</sup> The addition of estrogen to GnRH agonist therapy to eliminate estrogen deficiency symptoms and prevent bone loss does not diminish its efficacy for treating hirsutism. Cyclic or continuous treatment with estrogen (e.g., 0.3–0.625 mg conjugated estrogens daily, or equivalent) and progestin (e.g., 5–10 mg medroxyprogesterone), or an estrogen–progestin contraceptive, can be used as “add back” strategy, particularly when GnRH agonist use is planned for longer than 3-month duration. Combined treatment decreases free testosterone concentrations to lower levels than GnRH therapy alone, due to the added benefit of increased SHBG concentrations induced by estrogen.<sup>195,196,197,198</sup> **Nevertheless, combined treatment with a GnRH agonist and oral contraceptives is no more effective than treatment with a GnRH agonist alone, and somewhat less effective than combined treatment with oral contraceptives and an antiandrogen.**<sup>199</sup>

GnRH agonist therapy can also be considered in management of women with ovarian hyperthecosis who typically have severe hyperandrogenism. However, the impact of treatment on their hirsutism may be less than expected, even when gonadotropin secretion is suppressed profoundly, because most also have severe insulin resistance with hyperinsulinemia driving their androgen production.<sup>200</sup> Adequate suppression of ovarian androgens may not be achieved in obese women, given

concomitant insulin resistance. Although a combination of GnRH agonist and metformin can be considered in situations of significant insulin resistance, it is important to appreciate that there data on efficacy of this combination against hirsutism are currently lacking.

## Glucocorticoids

Glucocorticoids are used to suppress endogenous ACTH secretion in the long-term management of women with classical CAH. They also have been used for the treatment of hirsutism in women with the nonclassical, late-onset form of the disorder, with varying benefit. **Although glucocorticoids suppress serum adrenal androgen levels effectively in women with nonclassical CAH, they are less effective than oral contraceptives or antiandrogens for the treatment of hirsutism.**<sup>201,202</sup> Consequently, glucocorticoid treatment has even less to offer women with other causes for hirsutism.<sup>194,203,204</sup>

## Eflornithine Hydrochloride

Eflornithine hydrochloride (13.9% cream) is a topically applied inhibitor of ornithine decarboxylase, an enzyme active in the dermal papilla that is essential for hair growth; it is not a depilatory agent. In clinical trials, twice daily application produced noticeable improvement in facial hair growth within a few weeks in the majority of patients. However, the drug must be used continuously, because hair growth reverts to pretreatment characteristics within approximately 8 weeks after treatment is discontinued.<sup>205</sup> When used in conjunction with laser hair removal, eflornithine produces a more rapid response than laser treatment alone.<sup>206,207</sup> Treatment with topical eflornithine hydrochloride is perhaps best suited for patients with mild facial hirsutism.

# Permanent Hair Removal

A number of options exist for the removal of unwanted hair including plucking, waxing, shaving, or use of depilatory agents and are commonly utilized by women with hirsutism; while effective to varying degrees, the results achieved are only temporary. After removal by plucking, new hair become apparent at the skin surface after approximately 6–8 weeks. Waxing can be used on larger areas of the body, but results last no longer. Both methods remove the entire hair but typically not the dermal papilla. Because shaving removes hair to a level only slightly below the skin surface, its results are short-lived and most women will need to shave again within 1–3 days. Electrolysis and photoepilation (laser and pulsed light therapies) strategies are aimed at destruction of the dermal papilla, and results of these interventions vary both in the magnitude of benefit and in degrees of permanence of hair removal.

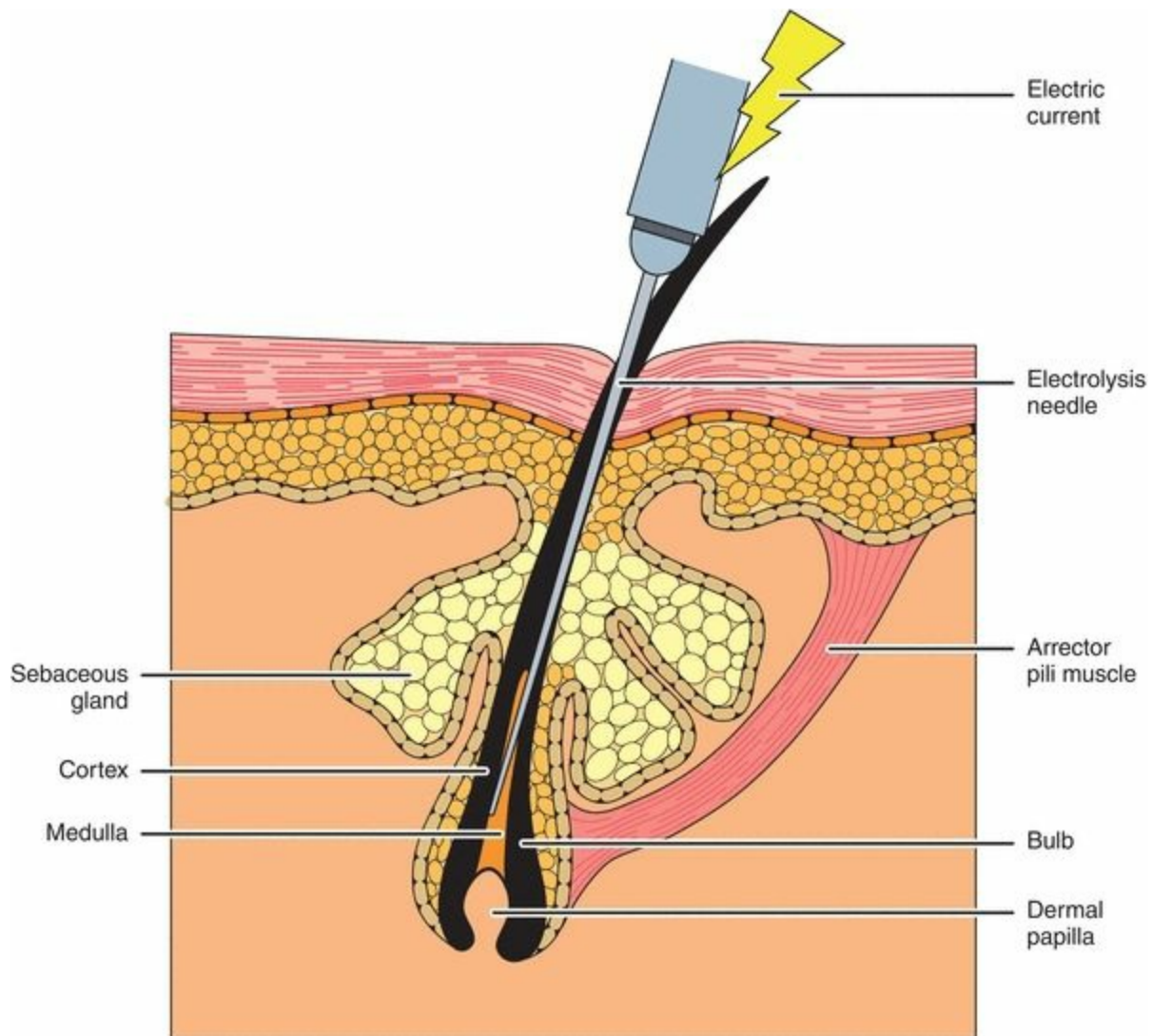
## Electrolysis

Electrolysis has been used as a method of permanent hair reduction for more than 100 years.<sup>208</sup> The earliest method, called galvanic electrolysis, used direct current applied to a fine needle inserted into the hair follicle, which produced sodium hydroxide from saline in tissues, causing a chemical destruction of the dermal papilla. Modern “thermolytic” techniques use high-frequency alternating current, causing thermal destruction of the hair follicle, or a “blend” of the two methods.<sup>209,210</sup>

Although electrolysis is an effective method of “permanent” hair reduction through damaging the dermal papilla,<sup>211</sup> hair growth recurs in up to 25% of women by 6 months after the treatment is discontinued.<sup>209,210</sup> In sensitive areas, topical anesthetic creams typically are applied first, because electrolysis can be painful. Electrolysis also can cause inflammation and erythema and, in some, pigmentation changes and scarring.

Unfortunately, there are no governing standards of practice for electrolysis and no formal training is required in many jurisdictions before starting a practice. In experienced hands, electrolysis can produce satisfying results, but the quality of care, and results, can vary considerably (**Figure 12.14**).





**FIGURE 12.14**

## Laser and Pulsed Light Therapies

Photoepilation therapies use laser or intense pulsed light to destroy hair follicles.<sup>212,213</sup> Both methods attempt to selectively target the hair bulb by using wavelengths absorbed specifically by melanin, but absorption by pigment in the epidermis also can occur. Consequently, they are best suited for light-skinned individuals with dark hair, in whom most of the energy will be absorbed by melanin in the hair bulb; the risk of burns and other complications such as postinflammatory pigment changes increases with the amount of skin pigmentation, although advances in technology are improving options for patients with darker skin.<sup>214,215,216</sup> Photoepilation therapies can be used for removal of any color of hair but, as might be expected, are more effective in patients with black or brown hair than in those with red or blonde hair.

Success rates achieved with laser and pulsed light therapies vary with hair growth

phase, skin and hair color, location, the type of laser, and the number of treatments.<sup>217,218</sup> Most patients require a series of four to six treatments at 4- to 6-week intervals to achieve the desired result,<sup>214</sup> followed by maintenance treatments every 6–12 months to remove any hairs that grow back.

Head-to-head split face comparison studies have demonstrated superiority of pulse light treatments over electrolysis in managing facial hirsutism.<sup>219</sup>

## Key Points: Treatment of Hirsutism

- The response to all medical treatments for hirsutism is relatively slow, generally requiring 6 months to achieve significant benefits, which approximates the duration of the life cycle of a hair follicle.
- In the absence of contraindications, the first treatment of choice for hirsutism, particularly if there is evidence of hyperandrogenemia, is a low-dose estrogen–progestin contraceptive.
- In patients having an inadequate response to treatment with estrogen–progestin contraceptives alone, an antiandrogen should be added, with spironolactone generally being the best choice.
- A trial of 5 $\alpha$ -reductase inhibitor can be considered in preference over spironolactone in hirsute women with normal circulating androgen profile.
- The use of GnRH agonists should be reserved for patients who fail to respond to or cannot tolerate more traditional treatments and particularly so in women with disproportionately high serum LH levels. GnRH agonist should be combined with sex steroid add-back therapy, which prevents the consequences of hypoestrogenism and does not diminish the efficacy of GnRH agonist treatment.
  - Permanent hair removal using electrolysis or photoepilation therapies (laser, pulsed light), when necessary, is best postponed until hormonal suppression has achieved its maximum benefits.

# REFERENCES

1. **Knochenhauer ES, Key TJ, Kahsar-Miller M**, et al., Prevalence of the polycystic ovary syndrome in unselected black and white women of the southeastern United States: a prospective study, *J Clin Endocrinol Metab* 83(9):3078, 1998.
2. **Paus R, Cotsarelis G**, The biology of hair follicles, *N Engl J Med* 341(7):491, 1999.
3. **Deplewski D, Rosenfield RL**, Role of hormones in pilosebaceous unit development, *Endocr Rev* 21(4):363, 2000.
4. **McDowall M, Edwards NM, Jahoda CA**, et al., The role of activins and follistatins in skin and hair follicle development and function, *Cytokine Growth Factor Rev* 19(5–6):415, 2008.
5. **Schneider MR, Schmidt-Ullrich R, Paus R**, The hair follicle as a dynamic miniorgan, *Curr Biol* 19(3):R132, 2009.
6. **Carmina E, Koyama T, Chang L**, et al., Does ethnicity influence the prevalence of adrenal hyperandrogenism and insulin resistance in polycystic ovary syndrome? *Am J Obstet Gynecol* 167(6):1807, 1992.
7. **Lookingbill DP, Demers LM, Wang C**, et al., Clinical and biochemical parameters of androgen action in normal healthy Caucasian versus Chinese subjects, *J Clin Endocrinol Metab* 72(6):1242, 1991.
8. **Azziz R, Carmina E, Sawaya ME**, Idiopathic hirsutism, *Endocr Rev* 21(4):347, 2000.
9. **Messenger AG**, The control of hair growth: an overview, *J Invest Dermatol* 101(1 Suppl):4S, 1993.
10. **Horton R**, Dihydrotestosterone is a peripheral paracrine hormone, *J Androl* 13(1):23, 1992.
11. **Randall VA, Ebling FJ**, Seasonal changes in human hair growth, *Br J Dermatol* 124(2):146, 1991.
12. **Burger HG**, Androgen production in women, *Fertil Steril* 77(Suppl 4):S3, 2002.
13. **Endoh A, Kristiansen SB, Casson PR**, et al., The zona reticularis is the site of biosynthesis of dehydroepiandrosterone and dehydroepiandrosterone sulfate in the adult human adrenal cortex resulting from its low expression of 3 beta-hydroxysteroid dehydrogenase, *J Clin Endocrinol Metab* 81(10):3558, 1996.
14. **Longcope C**, Adrenal and gonadal androgen secretion in normal females, *Clin Endocrinol Metab* 15(2):213, 1986.
15. **Horton R, Tait JF**, Androstenedione production and interconversion rates measured in peripheral blood and studies on the possible site of its conversion to testosterone, *J Clin Invest* 45(3):301, 1966.
16. **Judd HL, Yen SS**, Serum androstenedione and testosterone levels during the menstrual cycle, *J Clin Endocrinol Metab* 36(3):475, 1973.
17. **Chang RJ**, Ovarian steroid secretion in polycystic ovarian disease, *Semin Reprod Endocrinol* 2:244, 1984. Copyright© 1984 by Thieme Medical Publishers, Inc.
18. **Abraham GE**, Ovarian and adrenal contribution to peripheral androgens during the menstrual cycle, *J Clin Endocrinol Metab* 39(2):340, 1974.
19. **Serafini P, Lobo RA**, Increased 5 alpha-reductase activity in idiopathic hirsutism, *Fertil Steril* 43(1):74, 1985.
20. **Serafini P, Ablan F, Lobo RA**, 5 alpha-Reductase activity in the genital skin of hirsute women, *J Clin Endocrinol Metab* 60(2):349, 1985.
21. **Paulson RJ, Serafini PC, Catalino JA**, et al., Measurements of 3 alpha,17 beta-androstenediol glucuronide in serum and urine and the correlation with skin 5 alpha-reductase activity, *Fertil Steril* 46(2):222, 1986.
22. **Judd HL, Judd GE, Lucas WE**, et al., Endocrine function of the postmenopausal ovary: concentration of androgens and estrogens in ovarian and peripheral vein blood, *J Clin Endocrinol Metab* 39(6):1020, 1974.
23. **Adashi EY**, The climacteric ovary as a functional gonadotropin-driven androgen-producing gland, *Fertil Steril* 62(1):20, 1994.
24. **Longcope C**, Androgen metabolism and the menopause, *Semin Reprod Endocrinol* 16(2):111, 1998.
25. **Judd HL, Lucas WE, Yen SS**, Effect of oophorectomy on circulating testosterone and androstenedione levels in patients with endometrial cancer, *Am J Obstet Gynecol* 118(6):793, 1974.
26. **Laughlin GA, Barrett-Connor E, Kritz-Silverstein D**, et al., Hysterectomy, oophorectomy, and endogenous sex hormone levels in older women: the Rancho Bernardo Study, *J Clin Endocrinol Metab* 85(2):645, 2000.

27. **Judd HL, Fournet N**, Changes of ovarian hormonal function with aging, *Exp Gerontol* 29(3–4):285, 1994.
28. **Dennefors BL, Janson PO, Knutson F**, et al., Steroid production and responsiveness to gonadotropin in isolated stromal tissue of human postmenopausal ovaries, *Am J Obstet Gynecol* 136(8):997, 1980.
29. **Dennefors BL, Janson PO, Hamberger L**, et al., Hilus cells from human postmenopausal ovaries: gonadotrophin sensitivity, steroid and cyclic AMP production, *Acta Obstet Gynecol Scand* 61(5):413, 1982.
30. **Nakano R, Shima K, Yamoto M**, et al., Binding sites for gonadotropins in human postmenopausal ovaries, *Obstet Gynecol* 73(2):196, 1989.
31. **Azziz R, Sanchez LA, Knochenhauer ES**, et al., Androgen excess in women: experience with over 1000 consecutive patients, *J Clin Endocrinol Metab* 89(2):453, 2004.
32. **Zawadzki JK, Dunaif A**, Diagnostic criteria for polycystic ovary syndrome: towards a rational approach. In: Dunaif A, Givens JR, Haseltine FP, Merriam GR, eds. *Polycystic Ovary Syndrome*. Blackwell Scientific Publications, Boston, 1992, pp. 377–384.
33. **Rotterdam ESHRE/ASRM-Sponsored PCOS Consensus Workshop Group**, Revised 2003 consensus on diagnostic criteria and long-term health risks related to polycystic ovary syndrome (PCOS), *Hum Reprod* 19(1):41, 2004.
34. **Azziz R, Carmina E, Dewailly D**, et al., The Androgen Excess and PCOS Society criteria for the polycystic ovary syndrome: the complete task force report, *Fertil Steril* 91(2):456, 2009.
35. **O'Driscoll JB, Mamtora H, Higginson J**, et al., A prospective study of the prevalence of clear-cut endocrine disorders and polycystic ovaries in 350 patients presenting with hirsutism or androgenic alopecia, *Clin Endocrinol (Oxf)* 41(2):231, 1994.
36. **Carmina E, Rosato F, Janni A**, et al., Extensive clinical experience: relative prevalence of different androgen excess disorders in 950 women referred because of clinical hyperandrogenism, *J Clin Endocrinol Metab* 91(1):2, 2006.
37. **Barbieri RL, Ryan KJ**, Hyperandrogenism, insulin resistance, and acanthosis nigricans syndrome: a common endocrinopathy with distinct pathophysiologic features, *Am J Obstet Gynecol* 147(1):90, 1983.
38. **Moller DE, Cohen O, Yamaguchi Y**, et al., Prevalence of mutations in the insulin receptor gene in subjects with features of the type A syndrome of insulin resistance, *Diabetes* 43(2):247, 1994.
39. **Geist SH, Gaines JA**, Diffuse luteinization of the ovaries associated with the masculinization syndrome, *Am J Obstet Gynecol* 43:975, 1942.
40. **Nagamani M, Vandinh T, Kolver ME**, Hyperinsulinemia in hyperthecosis of the ovaries, *Am J Obstet Gynecol* 154(2):384, 1986.
41. **Nagamani M, Hannigan EV, Dinh TV**, et al., Hyperinsulinemia and stromal luteinization of the ovaries in postmenopausal women with endometrial cancer, *J Clin Endocrinol Metab* 67(1):144, 1988.
42. **Goldman JM, Kapadia LJ**, Virilization in a postmenopausal woman due to ovarian stromal hyperthecosis, *Postgrad Med J* 67(785):304, 1991.
43. **Barth JH, Jenkins M, Belchetz PE**, Ovarian hyperthecosis, diabetes and hirsuties in post-menopausal women, *Clin Endocrinol (Oxf)* 46(2):123, 1997.
44. **Moore A, Magee F, Cunningham S**, et al., Adrenal abnormalities in idiopathic hirsutism, *Clin Endocrinol (Oxf)* 18(4):391, 1983.
45. **Glickman SP, Rosenfield RL**, Androgen metabolism by isolated hairs from women with idiopathic hirsutism is usually normal, *J Invest Dermatol* 82(1):62, 1984.
46. **EscobarMorreale HF, SerranoGotarredona J, GarciaRobes R**, et al., Mild adrenal and ovarian steroidogenic abnormalities in hirsute women without hyperandrogenemia: does idiopathic hirsutism exist? *Metabolism* 46(8):902, 1997.
47. **Chetkowski RJ, Defazio J, Shamonki I**, et al., The incidence of late-onset congenital adrenal-hyperplasia due to 21-hydroxylase deficiency among hirsute women, *J Clin Endocrinol Metab* 58(4):595, 1984.
48. **Kuttann F, Couillin P, Girard F**, et al., Late-onset adrenal-hyperplasia in hirsutism, *N Engl J Med* 313(4):224, 1985.
49. **Dewailly D, Vantyghem MC, Lemaire C**, et al., Screening heterozygotes for 21-hydroxylase deficiency among hirsute women—lack of utility of the adrenocorticotropic hormone test, *Fertil Steril* 50(2):228, 1988.

50. **Hawkins LA, Chasalow FI, Blethen SL**, The role of adrenocorticotropin testing in evaluating girls with premature adrenarche and hirsutism oligomenorrhea, *J Clin Endocrinol Metab* 74(2):248, 1992.
51. **Meldrum DR, Abraham GE**, Peripheral and ovarian venous concentrations of various steroid-hormones in virilizing ovarian tumors, *Obstet Gynecol* 53(1):36, 1979.
52. **Friedman CI, Schmidt GE, Kim MH**, et al., Serum testosterone concentrations in the evaluation of androgen-producing tumors, *Am J Obstet Gynecol* 153(1):44, 1985.
53. **Moltz L, Pickartz H, Sorensen R**, et al., Ovarian and adrenal vein steroids in 7 patients with androgen-secreting ovarian neoplasms—selective catheterization findings, *Fertil Steril* 42(4):585, 1984.
54. **Derksen J, Nagesser SK, Meinders AE**, et al., Identification of virilizing adrenal-tumors in hirsute women, *N Engl J Med* 331(15):968, 1994.
55. **Seppala M, Hirvonen E**, Raised serum prolactin levels associated with hirsutism and amenorrhea, *Br Med J* 4(5989):144, 1975.
56. **Buvat J, Buvatherbaut M, Marcolin G**, et al., A double-blind controlled-study of the hormonal and clinical effects of bromocriptine in the polycystic-ovary-syndrome, *J Clin Endocrinol Metab* 63(1):119, 1986.
57. **Glasow A, Breidert M, Haidan A**, et al., Functional aspects of the effect of prolactin (PRL) on adrenal steroidogenesis and distribution of the PRL receptor in the human adrenal gland, *J Clin Endocrinol Metab* 81(8):3103, 1996.
58. **Mcclamrock HD, Adashi EY**, Gestational hyperandrogenism, *Fertil Steril* 57(2):257, 1992.
59. **Garciabunuel R, Berek JS, Woodruff JD**, Luteomas of pregnancy, *Obstet Gynecol* 45(4):407, 1975.
60. **Spitzer RF, Wherrett D, Chitayat D**, et al., Maternal luteoma of pregnancy presenting with virilization of the female infant, *J Obstet Gynaecol Can* 29(10):835, 2007.
61. **Joshi R, Dunaif A**, Ovarian disorders of pregnancy, *Endocrinol Metab Clin North Am* 24(1):153, 1995.
62. **Shortle BE, Warren MP, Tsin D**, Recurrent androgenicity in pregnancy: a case report and literature review, *Obstet Gynecol* 70(3 Pt 2):462, 1987.
63. **Nagamani M, Gomez LG, Garza J**, In vivo steroid studies in luteoma of pregnancy, *Obstet Gynecol* 59(6 Suppl):105S, 1982.
64. **Magendantz HG, Jones DE, Schomberg DW**, Virilization during pregnancy associated with polycystic ovary disease, *Obstet Gynecol* 40(2):156, 1972.
65. **Ben-Chetrit A, Greenblatt EM**, Recurrent maternal virilization during pregnancy associated with polycystic ovarian syndrome: a case report and review of the literature, *Hum Reprod* 10(11):3057, 1995.
66. **Wajda KJ, Lucas JG, Marsh WL**, Hyperreactio-Luteinalis—benign disorder masquerading as an ovarian neoplasm, *Arch Pathol Lab Med* 113(8):921, 1989.
67. **Azziz R, Zacur HA**, 21-Hydroxylase deficiency in female hyperandrogenism—screening and diagnosis, *J Clin Endocrinol Metab* 69(3):577, 1989.
68. **Romaguera J, Moran C, Diaz-Montes TP**, et al., Prevalence of 21-hydroxylase-deficient nonclassic adrenal hyperplasia and insulin resistance among hirsute women from Puerto Rico, *Fertil Steril* 74(1):59, 2000.
69. **Speiser PW**, Congenital adrenal hyperplasia owing to 21-hydroxylase deficiency, *Endocrinol Metab Clin North Am* 30(1):31, 2001.
70. **Yildiz BO, Bolour S, Woods K**, et al., Visually scoring hirsutism, *Hum Reprod Update* 16(1):51, 2010.
71. **Wang ET, Kao CN, Shinkai K**, et al., Phenotypic comparison of Caucasian and Asian women with polycystic ovary syndrome: a cross-sectional study, *Fertil Steril* 100(1):214, 2013.
72. **Chan JL, Kar S, Vanky E**, et al., Racial and ethnic differences in the prevalence of metabolic syndrome and its components of metabolic syndrome in women with polycystic ovary syndrome: a regional cross-sectional study, *Am J Obstet Gynecol* 217(2):189.e1, 2017.
73. **Ferriman D, Gallwey JD**, Clinical assessment of body hair growth in women, *J Clin Endocrinol Metab* 21(11):1440, 1961.
74. **Hatch R, Rosenfield RL, Kim MH**, et al., Hirsutism—implications, etiology, and management, *Am J Obstet Gynecol* 140(7):815, 1981.
75. **Escobar-Morreale HF, Carmina E, Dewailly D**, et al., Epidemiology, diagnosis and management of hirsutism: a consensus statement by the Androgen Excess and Polycystic Ovary Syndrome Society, *Hum*

Reprod Update 18(2):146, 2012.

76. **Zhao Y, Qiao J**, Ethnic differences in the phenotypic expression of polycystic ovary syndrome, *Steroids* 78(8):755, 2013.
77. **Huang ZW, Yong EL**, Ethnic differences: is there an Asian phenotype for polycystic ovarian syndrome? *Best Pract Res Clin Obstet Gynaecol* 37:46, 2016.
78. **DeUgarte CM, Woods KS, Bartolucci AA**, et al., Degree of facial and body terminal hair growth in unselected black and white women: toward a populational definition of hirsutism, *J Clin Endocrinol Metab* 91(4):1345, 2006.
79. **Lloyd J, Crouch NS, Minto CL**, et al., Female genital appearance: “normality” unfolds, *BJOG* 112(5):643, 2005.
80. **Verkauf BS, Von Thron J, O’Brien WF**, Clitoral size in normal women, *Obstet Gynecol* 80(1):41, 1992.
81. **Tagatz GE, Kopher RA, Nagel TC**, et al., The clitoral index: a bioassay of androgenic stimulation, *Obstet Gynecol* 54(5):562, 1979.
82. **Bardin CW, Lipsett MB**, Testosterone and androstenedione blood production rates in normal women and women with idiopathic hirsutism or polycystic ovaries, *J Clin Invest* 46(5):891, 1967.
83. **Futterweit W, Dunaif A, Yeh HC**, et al., The prevalence of hyperandrogenism in 109 consecutive female patients with diffuse alopecia, *J Am Acad Dermatol* 19(5 Pt 1):831, 1988.
84. **Reid RL, van Vugt DA**, Hair loss in the female, *Obstet Gynecol Surv* 43(3):135, 1988.
85. **Matteri RK, Stanczyk FZ, Gentschein EE**, et al., Androgen sulfate and glucuronide conjugates in nonhirsute and hirsute women with polycystic ovarian syndrome, *Am J Obstet Gynecol* 161(6 Pt 1):1704, 1989.
86. **Legro RS, Carmina E, Stanczyk FZ**, et al., Alterations in androgen conjugate levels in women and men with alopecia, *Fertil Steril* 62(4):744, 1994.
87. **Carmina E, Lobo RA**, Evidence for increased androsterone metabolism in some normoandrogenic women with acne, *J Clin Endocrinol Metab* 76(5):1111, 1993.
88. **Reingold SB, Rosenfield RL**, The relationship of mild hirsutism or acne in women to androgens, *Arch Dermatol* 123(2):209, 1987.
89. **Chang WY, Knochenhauer ES, Bartolucci AA**, et al., Phenotypic spectrum of polycystic ovary syndrome: clinical and biochemical characterization of the three major clinical subgroups, *Fertil Steril* 83(6):1717, 2005.
90. **Ikhena DE, Williams J, Naqvi N**, et al., Predictors of scalp hair thinning in women with polycystic ovary syndrome, *US Endocrinol* 12(1):26, 2016.
91. **Rosenfield RL**, Clinical practice. Hirsutism, *N Engl J Med* 353(24):2578, 2005.
92. **Martin KA, Anderson RR, Chang RJ**, et al., Evaluation and treatment of hirsutism in premenopausal women: an endocrine society clinical practice guideline, *J Clin Endocrinol Metab* 103:1233, 2018.
93. **Kamilaris TC, DeBold CR, Manolas KJ**, et al., Testosterone-secreting adrenal adenoma in a peripubertal girl, *JAMA* 258(18):2558, 1987.
94. **Easterling WE Jr, Talbert LM, Potter HD**, Serum testosterone levels in the polycystic ovary syndrome. Effect of an estrogen-progestin on protein binding of testosterone, *Am J Obstet Gynecol* 120(3):385, 1974.
95. **Miller KK, Rosner W, Lee H**, et al., Measurement of free testosterone in normal women and women with androgen deficiency: comparison of methods, *J Clin Endocrinol Metab* 89(2):525, 2004.
96. **Gruschke A, Kuhl H**, Validity of radioimmunological methods for determining free testosterone in serum, *Fertil Steril* 76(3):576, 2001.
97. **Morley JE, Patrick P, Perry HM III**, Evaluation of assays available to measure free testosterone, *Metabolism* 51(5):554, 2002.
98. **Le M, Flores D, May D**, et al., Current practices of measuring and reference range reporting of free and total testosterone in the United States, *J Urol* 195(5):1556, 2016.
99. **Sodergard R, Backstrom T, Shanbhag V**, et al., Calculation of free and bound fractions of testosterone and estradiol-17beta- to human-plasma proteins at body-temperature, *J Steroid Biochem Mol Biol* 16(6):801, 1982.
100. **Vermeulen A, Verdonck L, Kaufman JM**, A critical evaluation of simple methods for the estimation of free testosterone in serum, *J Clin Endocrinol Metab* 84(10):3666, 1999.
101. **Surrey ES, Deziegler D, Gambone JC**, et al., Preoperative localization of androgen-secreting tumors—

- clinical, endocrinologic, and radiologic evaluation of 10 patients, *Am J Obstet Gynecol* 158(6):1313, 1988.
102. **Waggoner W, Boots LR, Azziz R**, Total testosterone and DHEAS levels as predictors of androgen-secreting neoplasms: a populational study, *Gynecol Endocrinol* 13(6):394, 1999.
  103. **Bammann BL, Coulam CB, Jiang NS**, Total and free testosterone during pregnancy, *Am J Obstet Gynecol* 137(3):293, 1980.
  104. **Haning RV, Flood CA, Hackett RJ**, et al., Metabolic clearance rate of dehydroepiandrosterone sulfate, its metabolism to testosterone, and its intrafollicular metabolism to dehydroepiandrosterone, androstenedione, testosterone, and dihydrotestosterone in vivo, *J Clin Endocrinol Metab* 72(5):1088, 1991.
  105. **Azziz R, Black V, Hines GA**, et al., Adrenal androgen excess in the polycystic ovary syndrome: sensitivity and responsiveness of the hypothalamic-pituitary-adrenal axis, *J Clin Endocrinol Metab* 83(7):2317, 1998.
  106. **Fujieda K, Faiman C, Feyes FI**, et al., The control of steroidogenesis by human fetal adrenal cells in tissue culture. IV. The effect of exposure to placental steroids, *J Clin Endocrinol Metab* 54(1):89, 1982.
  107. **Gell JS, Carr BR, Sasano H**, et al., Adrenarche results from development of a 3beta-hydroxysteroid dehydrogenase-deficient adrenal reticularis, *J Clin Endocrinol Metab* 83(10):3695, 1998.
  108. **Molta L, Schwartz U**, Gonadal and adrenal androgen secretion in hirsute females, *Clin Endocrinol Metab* 15(2):229, 1986.
  109. **Heinz-Peer G, Memarsadeghi M, Niederle B**, Imaging of adrenal masses, *Curr Opin Urol* 17(1):32, 2007.
  110. **Wentz AC, White RI, Migeon CJ**, et al., Differential ovarian and adrenal vein catheterization, *Am J Obstet Gynecol* 125(7):1000, 1976.
  111. **Kirschner MA, Jacobs JB**, Combined ovarian and adrenal vein catheterization to determine site(s) of androgen overproduction in hirsute women, *J Clin Endocrinol Metab* 33(2):199, 1971.
  112. **Sorensen R, Moltz L, Schwartz U**, Technical difficulties of selective venous-blood sampling in the differential-diagnosis of female hyperandrogenism, *Cardiovasc Intervent Radiol* 9(2):75, 1986.
  113. **Levens ED, Whitcomb BW, Csokmay JM**, et al., Selective venous sampling for androgen-producing ovarian pathology, *Clin Endocrinol (Oxf)* 70(4):606, 2009.
  114. **Gabrilove JL, Seman AT, Sabet R**, et al., Virilizing adrenal adenoma with studies on the steroid content of the adrenal venous effluent and a review of the literature, *Endocr Rev* 2(4):462, 1981.
  115. **Brumsted JR, Chapitis J, Riddick D**, et al., Norethindrone inhibition of testosterone secretion by an ovarian Sertoli-Leydig cell tumor, *J Clin Endocrinol Metab* 65(1):194, 1987.
  116. **Ehrmann DA, Rosenfield RL, Barnes RB**, et al., Detection of functional ovarian hyperandrogenism in women with androgen excess, *N Engl J Med* 327(3):157, 1992.
  117. **Kennedy L, Traub AI, Atkinson AB**, et al., Short-term administration of gonadotropin-releasing-hormone analog to a patient with a testosterone-secreting ovarian tumor, *J Clin Endocrinol Metab* 64(6):1320, 1987.
  118. **Pascale MM, Pugeat M, Roberts M**, et al., Androgen suppressive effect of GnRH agonist in ovarian hyperthecosis and virilizing tumors, *Clin Endocrinol (Oxf)* 41(5):571, 1994.
  119. **Cohen I, Shapira M, Cuperman S**, et al., Direct in-vivo detection of atypical hormonal expression of a Sertoli-Leydig cell tumor following stimulation with human chorionic-gonadotropin, *Clin Endocrinol (Oxf)* 39(4):491, 1993.
  120. **Landay M, Huang A, Azziz R**, Degree of hyperinsulinemia, independent of androgen levels, is an important determinant of the severity of hirsutism in PCOS, *Fertil Steril* 92(2):643, 2009.
  121. **American Association of Clinical Endocrinologists Polycystic Ovary Syndrome Writing Committee**, American Association of clinical endocrinologists position statement on metabolic and cardiovascular consequences of polycystic ovary syndrome, *Endocr Pract* 11(2):126, 2005.
  122. **Salley KE, Wickham EP, Cheang KI**, et al., Glucose intolerance in polycystic ovary syndrome—a position statement of the Androgen Excess Society, *J Clin Endocrinol Metab* 92(12):4546, 2007.
  123. **Ehrmann DA, Barnes RB, Rosenfield RL**, et al., Prevalence of impaired glucose tolerance and diabetes in women with polycystic ovary syndrome, *Diabetes Care* 22(1):141, 1999.
  124. **Cosma M, Swiglo BA, Flynn DN**, et al., Insulin sensitizers for the treatment of hirsutism: a systematic review and metaanalyses of randomized controlled trials, *J Clin Endocrinol Metab* 93(4):1135, 2008.
  125. **Kokaly W, McKenna TJ**, Relapse of hirsutism following long-term successful treatment with oestrogen-

progestogen combination, *Clin Endocrinol (Oxf)* 52(3):379, 2000.

126. **Lumachi F, Rondinone R**, Use of cyproterone acetate, finasteride, and spironolactone to treat idiopathic hirsutism, *Fertil Steril* 79(4):942, 2003.
127. **Kirschner MA, Samojlik E, Szmaj E**, Clinical usefulness of plasma androstenediol glucuronide measurements in women with idiopathic hirsutism, *J Clin Endocrinol Metab* 65(4):597, 1987.
128. **Givens JR, Andersen RN, Wiser WL**, et al., Dynamics of suppression and recovery of plasma FSH, LH, androstenedione and testosterone in polycystic ovarian disease using an oral-contraceptive, *J Clin Endocrinol Metab* 38(5):727, 1974.
129. **Givens JR, Andersen RN, Wiser WL**, et al., The effectiveness of two oral contraceptives in suppressing plasma androstenedione, testosterone, LH, and FSH, and in stimulating plasma testosterone-binding capacity in hirsute women, *Am J Obstet Gynecol* 124(4):333, 1976.
130. **Raj SG, Raj MHG, Talbert LM**, et al., Normalization of testosterone levels using a low estrogen-containing oral-contraceptive in women with polycystic ovary syndrome, *Obstet Gynecol* 60(1):15, 1982.
131. **Dewis P, Petsos P, Newman M**, et al., The treatment of hirsutism with a combination of desogestrel and ethinyl estradiol, *Clin Endocrinol (Oxf)* 22(1):29, 1985.
132. **Cullberg G, Hamberger L, Mattsson LA**, et al., Effects of a low-dose desogestrel-ethinylestradiol combination on hirsutism, androgens and sex-hormone binding globulin in women with a polycystic ovary syndrome, *Acta Obstet Gynecol Scand* 64(3):195, 1985.
133. **Granger LR, Roy S, Mishell DR Jr**, Changes in unbound sex steroids and sex hormone binding globulin—binding capacity during oral and vaginal progestogen administration, *Am J Obstet Gynecol* 144(5):578, 1982.
134. **Madden JD, Milewich L, Parker CR Jr**, et al., The effect of oral contraceptive treatment on the serum concentration of dehydroisoandrosterone sulfate, *Am J Obstet Gynecol* 132(4):380, 1978.
135. **Fern M, Rose DP, Fern EB**, Effect of oral-contraceptives on plasma androgenic steroids and their precursors, *Obstet Gynecol* 51(5):541, 1978.
136. **Wild RA, Umstot ES, Andersen RN**, et al., Adrenal function in hirsutism. II. Effect of an oral contraceptive, *J Clin Endocrinol Metab* 54(4):676, 1982.
137. **Wiebe RH, Morris CV**, Effect of an oral contraceptive on adrenal and ovarian androgenic steroids, *Obstet Gynecol* 63(1):12, 1984.
138. **Cassidenti DL, Paulson RJ, Serafini P**, et al., Effects of sex steroids on skin 5 alpha-reductase activity in vitro, *Obstet Gynecol* 78(1):103, 1991.
139. **Bhattacharya SM, Jha A**, Comparative study of the therapeutic effects of oral contraceptive pills containing desogestrel, cyproterone acetate, and drospirenone in patients with polycystic ovary syndrome, *Fertil Steril* 98(4):1053, 2012.
140. **van Zuuren EJ, Fedorowicz Z, Carter B**, et al., Interventions for hirsutism (excluding laser and photoepilation therapy alone). *Cochrane Database Syst Rev* (4):CD010334, 2015.
141. **Kriplani A, Periyasamy AJ, Agarwal N**, et al., Effect of oral contraceptive containing ethinyl estradiol combined with drospirenone vs. desogestrel on clinical and biochemical parameters in patients with polycystic ovary syndrome, *Contraception* 82(2):139, 2010.
142. **Luque-Ramirez M, Nattero-Chavez L, Ortiz Flores AE**, et al., Combined oral contraceptives and/or antiandrogens versus insulin sensitizers for polycystic ovary syndrome: a systematic review and meta-analysis. *Hum Reprod Update* 24(2): 225–241, 2017.
143. **van der Vange N, Blankenstein MA, Kloosterboer HJ**, et al., Effects of seven low-dose combined oral contraceptives on sex hormone binding globulin, corticosteroid binding globulin, total and free testosterone, *Contraception* 41(4):345, 1990.
144. **Lemay A, Dewailly SD, Grenier R**, et al., Attenuation of mild hyperandrogenic activity in postpubertal acne by a triphasic oral contraceptive containing low doses of ethinyl estradiol and D,L-norgestrel, *J Clin Endocrinol Metab* 71(1):8, 1990.
145. **Palatsi R, Hirvensalo E, Liukko P**, et al., Serum total and unbound testosterone and sex hormone binding globulin (SHBG) in female acne patients treated with two different oral contraceptives, *Acta Derm Venereol* 64(6):517, 1984.



146. **Coenen CM, Thomas CM, Borm GF**, et al., Changes in androgens during treatment with four low-dose contraceptives, *Contraception* 53(3):171, 1996.
147. **Breitkopf DM, Rosen MP, Young SL**, et al., Efficacy of second versus third generation oral contraceptives in the treatment of hirsutism, *Contraception* 67(5):349, 2003.
148. **Elger W, Beier S, Pollow K**, et al., Conception and pharmacodynamic profile of drospirenone, *Steroids* 68(10–13):891, 2003.
149. **Mathur R, Levin O, Azziz R**, Use of ethinylestradiol/drospirenone combination in patients with the polycystic ovary syndrome, *Ther Clin Risk Manag* 4(2):487, 2008.
150. **van Vloten WA, van Haselen CW, van Zuuren EJ**, et al., The effect of 2 combined oral contraceptives containing either drospirenone or cyproterone acetate on acne and seborrhea, *Cutis* 69(4 Suppl):2, 2002.
151. **Sanam M, Ziba O**, Desogestrel+ethinylestradiol versus levonorgestrel+ethinylestradiol. Which one has better affect on acne, hirsutism, and weight change, *Saudi Med J* 32(1):23, 2011.
152. **White T, Jain JK, Stanczyk FZ**, Effect of oral versus transdermal steroidal contraceptives on androgenic markers, *Am J Obstet Gynecol* 192(6):2055, 2005.
153. **Gordon GG, Southren AL, Tochimoto S**, et al., Effect of medroxyprogesterone acetate (Provera) on the metabolism and biological activity of testosterone, *J Clin Endocrinol Metab* 30(4):449, 1970.
154. **Wortzman J, Khan MS, Rosner W**, Suppression of testosterone-estradiol binding globulin by medroxyprogesterone acetate in polycystic ovary syndrome, *Obstet Gynecol* 67(5):705, 1986.
155. **Guido M, Romualdi D, Giuliani M**, et al., Drospirenone for the treatment of hirsute women with polycystic ovary syndrome: a clinical, endocrinological, metabolic pilot study, *J Clin Endocrinol Metab* 89(6):2817, 2004.
156. **Batukan C, Muderris II**, Efficacy of a new oral contraceptive containing drospirenone and ethinyl estradiol in the long-term treatment of hirsutism, *Fertil Steril* 85(2):436, 2006.
157. **Venturoli S, Marescalchi O, Colombo FM**, et al., A prospective randomized trial comparing low dose flutamide, finasteride, ketoconazole, and cyproterone acetate-estrogen regimens in the treatment of hirsutism, *J Clin Endocrinol Metab* 84(4):1304, 1999.
158. **Redmond GP, Olson WH, Lippman JS**, et al., Norgestimate and ethinyl estradiol in the treatment of acne vulgaris: a randomized, placebo-controlled trial, *Obstet Gynecol* 89(4):615, 1997.
159. **Völpe A, Silferi M, Mauri A**, et al., Efficacy on hyperandrogenism and safety of a new oral contraceptive biphasic formulation containing desogestrel, *Eur J Obstet Gynecol Reprod Biol* 53(3):205, 1994.
160. **Young RL, Goldzieher JW, Elkindhirsch K**, The endocrine effects of spironolactone used as an antiandrogen, *Fertil Steril* 48(2):223, 1987.
161. **Lobo RA, Shoupe D, Serafini P**, et al., The effects of two doses of spironolactone on serum androgens and anagen hair in hirsute women, *Fertil Steril* 43(2):200, 1985.
162. **Evans DJ, Burke CW**, Spironolactone in the treatment of idiopathic hirsutism and the polycystic ovary syndrome, *J R Soc Med* 79(8):451, 1986.
163. **Barth JH, Cherry CA, Wojnarowska F**, et al., Spironolactone is an effective and well tolerated systemic antiandrogen therapy for hirsute women, *J Clin Endocrinol Metab* 68(5):966, 1989.
164. **Brown J, Farquhar C, Lee O**, et al., Spironolactone versus placebo or in combination with steroids for hirsutism and/or acne, *Cochrane Database Syst Rev* (2):CD000194, 2009.
165. **McLellan AR, Rentoul J, Mackie R**, et al., Lack of effect of spironolactone on hair shaft diameter in hirsute females, *Postgrad Med J* 65(765):459, 1989.
166. **Moggetti P, Tosi F, Tosti A**, et al., Comparison of spironolactone, flutamide, and finasteride efficacy in the treatment of hirsutism: a randomized, double blind, placebo-controlled trial, *J Clin Endocrinol Metab* 85(1):89, 2000.
167. **Pittaway DE, Maxson WS, Wentz AC**, Spironolactone in combination-drug therapy for unresponsive hirsutism, *Fertil Steril* 43(6):878, 1985.
168. **Kelestimir F, Sahin Y**, Comparison of Diane 35 and Diane 35 plus spironolactone in the treatment of hirsutism, *Fertil Steril* 69(1):66, 1998.
169. **Swiglo BA, Cosma M, Flynn DN**, et al., Antiandrogens for the treatment of hirsutism: a systematic review and metaanalyses of randomized controlled trials, *J Clin Endocrinol Metab* 93(4):1153, 2008.

170. **Belisle S, Love EJ**, Clinical efficacy and safety of cyproterone-acetate in severe hirsutism—results of a multicentered Canadian study, *Fertil Steril* 46(6):1015, 1986.
171. **Barth JH, Cherry CA, Wojnarowska F**, et al., Cyproterone acetate for severe hirsutism: results of a double-blind dose-ranging study, *Clin Endocrinol (Oxf)* 35(1):5, 1991.
172. **Van der Spuy ZM, le Roux PA**, Cyproterone acetate for hirsutism, *Cochrane Database Syst Rev* (4):CD001125, 2003.
173. **Russell DW, Wilson JD**, Steroid 5 alpha-reductase: two genes/two enzymes, *Annu Rev Biochem* 63:25, 1994.
174. **Wong IL, Morris RS, Chang L**, et al., A prospective randomized trial comparing finasteride to spironolactone in the treatment of hirsute women, *J Clin Endocrinol Metab* 80(1):233, 1995.
175. **Marcondes JA, Minnani SL, Luthold WW**, et al., Treatment of hirsutism in women with flutamide, *Fertil Steril* 57(3):543, 1992.
176. **Cusan L, Dupont A, Gomez JL**, et al., Comparison of flutamide and spironolactone in the treatment of hirsutism: a randomized controlled trial, *Fertil Steril* 61(2):281, 1994.
177. **Wysowski DK, Freiman JP, Tourtelot JB**, et al., Fatal and nonfatal hepatotoxicity associated with flutamide, *Ann Intern Med* 118(11):860, 1993.
178. **Wysowski DK, Fourcroy JL**, Flutamide hepatotoxicity, *J Urol* 155(1):209, 1996.
179. **Kelestimir F, Everest H, Unluhizarci K**, et al., A comparison between spironolactone and spironolactone plus finasteride in the treatment of hirsutism, *Eur J Endocrinol* 150(3):351, 2004.
180. **Unluhizarci K, Everest H, Bayram F**, et al., Comparison of spironolactone and spironolactone plus finasteride in the treatment of hirsutism. *Fertil Steril* 78(6):1331, 2002.
181. **Morin-Papunen LC, Vauhkonen I, Koivunen RM**, et al., Endocrine and metabolic effects of metformin versus ethinyl estradiol-cyproterone acetate in obese women with polycystic ovary syndrome: a randomized study, *J Clin Endocrinol Metab* 85(9):3161, 2000.
182. **Moggetti P, Castello R, Negri C**, et al., Metformin effects on clinical features, endocrine and metabolic profiles, and insulin sensitivity in polycystic ovary syndrome: a randomized, double-blind, placebo-controlled 6-month trial, followed by open, long-term clinical evaluation, *J Clin Endocrinol Metab* 85(1):139, 2000.
183. **Ehrmann DA, Schneider DJ, Sobel BE**, et al., Troglitazone improves defects in insulin action, insulin secretion, ovarian steroidogenesis, and fibrinolysis in women with polycystic ovary syndrome, *J Clin Endocrinol Metab* 82(7):2108, 1997.
184. **Ehrmann DA, Cavaghan MK, Imperial J**, et al., Effects of metformin on insulin secretion, insulin action, and ovarian steroidogenesis in women with polycystic ovary syndrome, *J Clin Endocrinol Metab* 82(2):524, 1997.
185. **Nestler JE, Jakubowicz DJ, Evans WS**, et al., Effects of metformin on spontaneous and clomiphene-induced ovulation in the polycystic ovary syndrome, *N Engl J Med* 338(26):1876, 1998.
186. **Velazquez EM, Mendoza S, Hamer T**, et al., Metformin therapy in polycystic-ovary-syndrome reduces hyperinsulinemia, insulin-resistance, hyperandrogenemia, and systolic blood-pressure, while facilitating normal menses and pregnancy, *Metabolism* 43(5):647, 1994.
187. **Nestler JE, Jakubowicz DJ**, Decreases in ovarian cytochrome P450c17 alpha activity and serum free testosterone after reduction of insulin secretion in polycystic ovary syndrome, *N Engl J Med* 335(9):617, 1996.
188. **Dunaif A, Scott D, Finegood D**, et al., The insulin-sensitizing agent troglitazone improves metabolic and reproductive abnormalities in the polycystic ovary syndrome, *J Clin Endocrinol Metab* 81(9):3299, 1996.
189. **Nestler JE, Jakubowicz DJ, Reamer P**, et al., Ovulatory and metabolic effects of D-chiro-inositol in the polycystic ovary syndrome, *N Engl J Med* 340(17):1314, 1999.
190. **Ibanez L, Valls C, Potau N**, et al., Sensitization to insulin in adolescent girls to normalize hirsutism, hyperandrogenism, oligomenorrhea, dyslipidemia, and hyperinsulinism after precocious pubarche, *J Clin Endocrinol Metab* 85(10):3526, 2000.
191. **Andreyko JL, Monroe SE, Jaffe RB**, Treatment of hirsutism with a gonadotropin-releasing-hormone agonist (nafarelin), *J Clin Endocrinol Metab* 63(4):854, 1986.
192. **Steingold K, Deziegler D, Cedars M**, et al., Clinical and hormonal effects of chronic gonadotropin-

- releasing-hormone agonist treatment in polycystic ovarian disease, *J Clin Endocrinol Metab* 65(4):773, 1987.
193. **Chang RJ, Laufer LR, Meldrum DR**, et al., Steroid secretion in polycystic ovarian disease after ovarian suppression by a long-acting gonadotropin-releasing hormone agonist, *J Clin Endocrinol Metab* 56(5):897, 1983.
  194. **Rittmaster RS, Thompson DL**, Effect of leuprolide and dexamethasone on hair growth and hormone levels in hirsute women: the relative importance of the ovary and the adrenal in the pathogenesis of hirsutism, *J Clin Endocrinol Metab* 70(4):1096, 1990.
  195. **Elkind-Hirsch KE, Anania C, Mack M**, et al., Combination gonadotropin-releasing hormone agonist and oral contraceptive therapy improves treatment of hirsute women with ovarian hyperandrogenism, *Fertil Steril* 63(5):970, 1995.
  196. **Falsetti L, Pasinetti E**, Treatment of moderate and severe hirsutism by gonadotropin-releasing hormone agonists in women with polycystic ovary syndrome and idiopathic hirsutism, *Fertil Steril* 61(5):817, 1994.
  197. **Ciotta L, Cianci A, Giuffrida G**, et al., Clinical and hormonal effects of gonadotropin-releasing hormone agonist plus an oral contraceptive in severely hirsute patients with polycystic ovary disease, *Fertil Steril* 65(1):61, 1996.
  198. **Azziz R, Ochoa TM, Bradley EL Jr**, et al., Leuprolide and estrogen versus oral contraceptive pills for the treatment of hirsutism: a prospective randomized study, *J Clin Endocrinol Metab* 80(12):3406, 1995.
  199. **Pazos F, Escobar-Morreale HF, Balsa J**, et al., Prospective randomized study comparing the long-acting gonadotropin-releasing hormone agonist triptorelin, flutamide, and cyproterone acetate, used in combination with an oral contraceptive, in the treatment of hirsutism, *Fertil Steril* 71(1):122, 1999.
  200. **Steingold KA, Judd HL, Nieberg RK**, et al., Treatment of severe androgen excess due to ovarian hyperthecosis with a long-acting gonadotropin-releasing-hormone agonist. *Am J Obstet Gynecol* 154(6):1241, 1986.
  201. **Spritzer P, Billaud L, Thalabard JC**, et al., Cyproterone-acetate versus hydrocortisone treatment in late-onset adrenal-hyperplasia, *J Clin Endocrinol Metab* 70(3):642, 1990.
  202. **Frank-Raue K, Junga G, Raue F**, et al., Therapy of hirsutism in females with adrenal enzyme defects of steroid hormone biosynthesis: comparison of dexamethasone with cyproterone acetate, *Klin Wochenschr* 68(12):597, 1990.
  203. **Carmina E, Lobo RA**, Peripheral androgen blockade versus glandular androgen suppression in the treatment of hirsutism, *Obstet Gynecol* 78(5 Pt 1):845, 1991.
  204. **Carmina E, Lobo RA**, The addition of dexamethasone to antiandrogen therapy for hirsutism prolongs the duration of remission, *Fertil Steril* 69(6):1075, 1998.
  205. **Wolf JE Jr, Shander D, Huber F**, et al., Randomized, double-blind clinical evaluation of the efficacy and safety of topical eflornithine HCl 13.9% cream in the treatment of women with facial hair, *Int J Dermatol* 46(1):94, 2007.
  206. **Smith SR, Piacquadio DJ, Beger B**, et al., Eflornithine cream combined with laser therapy in the management of unwanted facial hair growth in women: a randomized trial, *Dermatol Surg* 32(10):1237, 2006.
  207. **Hamzavi I, Tan E, Shapiro J**, et al., A randomized bilateral vehicle-controlled study of eflornithine cream combined with laser treatment versus laser treatment alone for facial hirsutism in women, *J Am Acad Dermatol* 57(1):54, 2007.
  208. **Michel CE**, Trichiasis and Distichiasis: Reflections Upon Their Nature and Pathology. With a Radical Method of Treatment. St Louis Courier of Med, 1879.
  209. **Wagner RF, Tomich JM, Grande DJ**, Electrolysis and thermolysis for permanent hair removal, *J Am Acad Dermatol* 12(3):441, 1985.
  210. **Olsen EA**, Methods of hair removal, *J Am Acad Dermatol* 40(2):143, 1999.
  211. **Urushibata O, Kase K**, A comparative study of axillar hair removal in women: plucking versus the blend method, *J Dermatol* 22(10):738, 1995.
  212. **Goldberg DJ**, Laser hair removal, *Dermatol Clin* 20(3):561, 2002.
  213. **Tse Y**, Hair removal using a pulsed-intense light source, *Dermatol Clin* 17(2):373, 1999.
  214. **Hussain M, Polnikorn N, Goldberg DJ**, Laser-assisted hair removal in Asian skin: efficacy, complications, and the effect of single versus multiple treatments, *Dermatol Surg* 29(3):249, 2003.

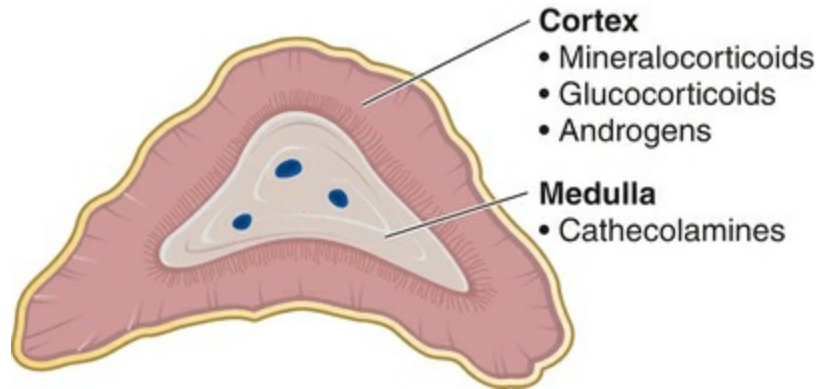
215. **Battle EF, Hobbs LM**, Laser therapy on darker ethnic skin, *Dermatol Clin* 21(4):713, 2003.
216. **Tanzi EL, Lupton JR, Alster TS**, Lasers in dermatology: four decades of progress, *J Am Acad Dermatol* 49(1):1, 2003.
217. **Liew SH, Grobbelaar AO, Gault D**, et al., Ruby laser-assisted hair removal: a preliminary report of the correlation between efficacy of treatment and melanin content of hair and the growth phases of hair at a specific site, *Ann Plast Surg* 42(3):255, 1999.
218. **McBurney EI**, Side effects and complications of laser therapy, *Dermatol Clin* 20(1):165, 2002.
219. **Harris K, Ferguson J, Hills S**, A comparative study of hair removal at an NHS hospital: luminette intense pulsed light versus electrolysis, *J Dermatolog Treat* 25(2):169, 2014.

# Reproduction and the Adrenal

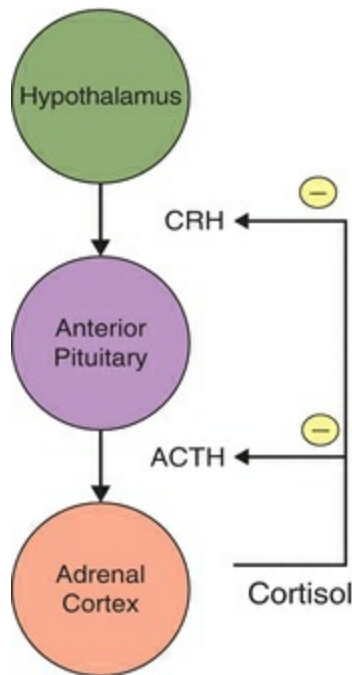
The adrenals are a pair of endocrine glands, one located along the upper medial pole of each kidney. Normal function of the adrenals is not just critical to survival but also contributes toward the earliest signs of physical and sexual maturity, namely, the development of axillary and pubic hair. Menstrual abnormalities such as oligomenorrhea or amenorrhea are often seen in women with adrenal disorders. On the other hand, certain adrenal disorders, the classic example being congenital adrenal hyperplasia (CAH), can mimic common gynecologic conditions, such as polycystic ovary syndrome (PCOS, discussed in detail in [Chapter 11](#)). **The goal of including this chapter in a gynecology textbook is to sensitize this readership to differential diagnoses to consider when evaluating women presenting with menstrual abnormalities, with features that mimic PCOS discussed in [Chapter 11](#), or manifesting certain clinical features that suggest the possibility of an underlying adrenal disorder.**<sup>1,2</sup> Detailed discussion on the management of adrenal disorders is beyond the scope of a gynecologist/reproductive endocrinologist, and patients should be referred promptly to an internist-endocrinologist for completion of evaluation and management.

Each adrenal gland is composed of two distinct hormone-producing compartments, the outer cortex, and the inner medulla ([Figure 13.1](#)). Adrenal cortical cells are organized into three distinct functional layers, each responsible for a distinct functional category of steroid hormones.<sup>3,4</sup> Cells constituting the outermost cortical layer, the zona granulosa, are responsible for secreting a class of hormones called mineralocorticoids. Mineralocorticoids, of which aldosterone is the prototype, are responsible for bodily fluid and electrolyte homeostasis, and their secretion is governed by the renal renin-angiotensin system. Glucocorticoids, of which cortisol is the prototype, are the second class of adrenal steroid hormones, which are secreted by cells that comprise the zona fasciculata of the adrenal cortex. Cortisol is critical to a number of biologic processes including cellular homeostasis, energy balance, and immunity. Adrenal secretion of cortisol is under the control of ACTH (adrenocorticotrophic hormone), and in turn, circulating cortisol maintains a tight control of secretion of both the ACTH (by the anterior pituitary) and of the hypothalamic CRH (corticotropin-releasing hormone) ([Figure 13.2](#)). It is the ACTH that drives the steps involved in the adrenal steroidogenic processes, starting from the initial step of transportation of the parent cholesterol from the cellular cytosol to the mitochondria, as well as regulating the synthesis of the

cytochrome P-450 enzymes that are involved in the steroidogenic pathways (**Figure 13.3**). The innermost layer of the adrenal cortex is the zona fasciculata, and cells of this layer contain the 17,21-lyase enzyme (CYP17/P450c17) that preferentially leads to production of the glucocorticoid precursors, 17-hydroxyprogesterone and 17-hydroxypregnenolone, intermediaries in the synthesis of androgens (see **Figure 13.3**).

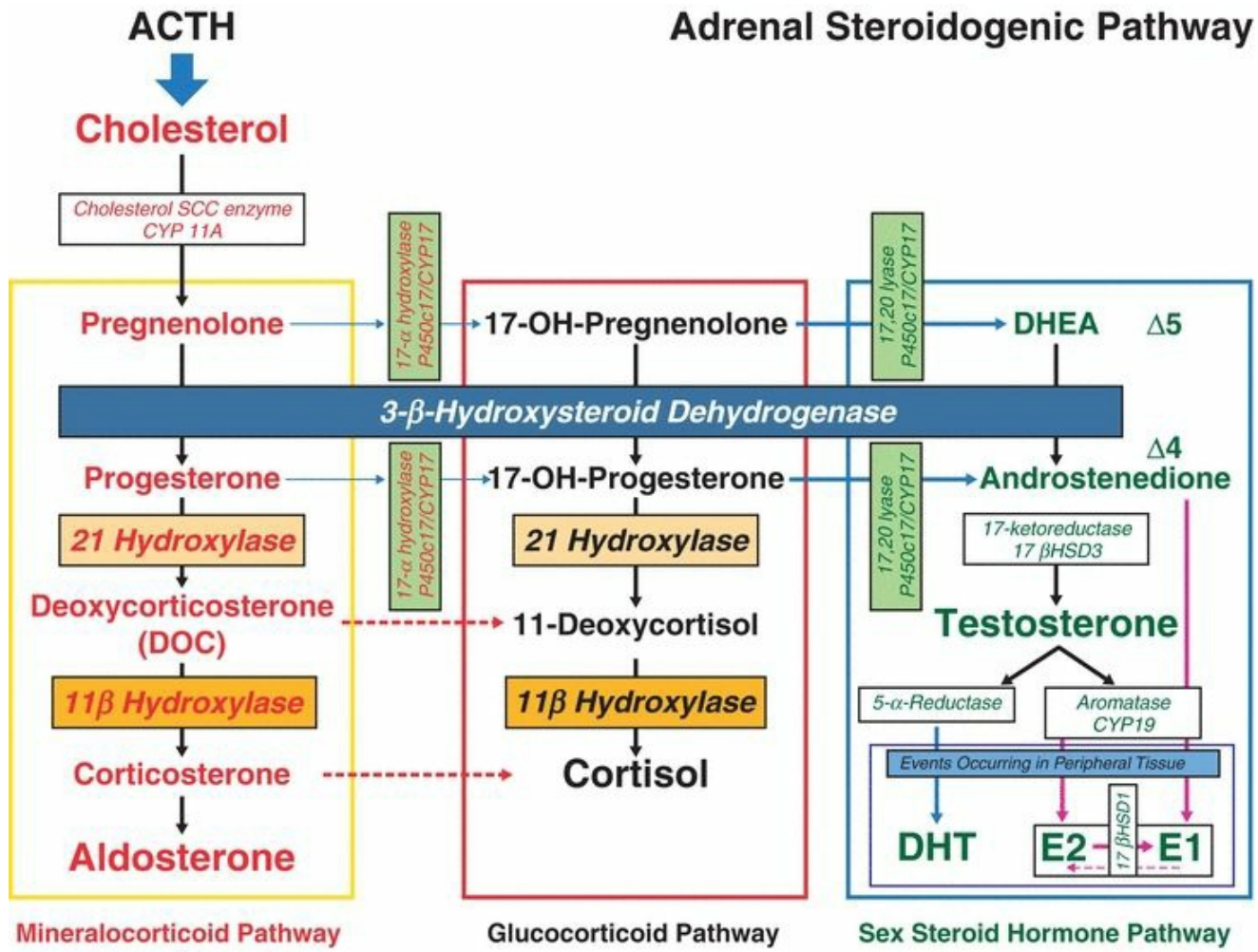


**FIGURE 13.1**



**FIGURE 13.2**

# Adrenal Steroidogenic Pathway



**FIGURE 13.3**

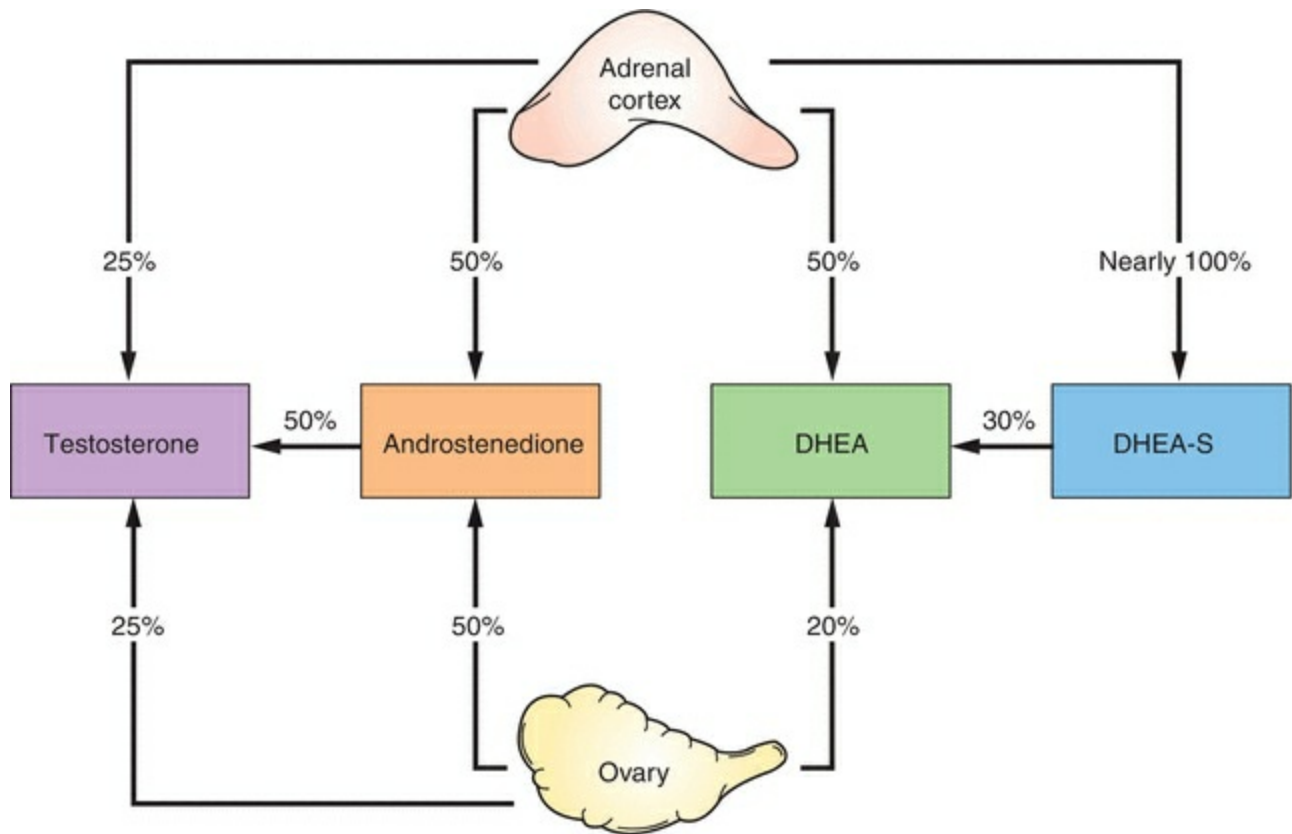
# ANDROGENS IN WOMEN

---

The ovaries and the adrenal cortex are the two major sources of circulating androgens in women. In women, the major circulating androgens (in descending order of serum concentration) are dehydroepiandrosterone sulfate (DHEA-S), dehydroepiandrosterone (DHEA), androstenedione, testosterone, and DHT.<sup>5,6,7,8</sup> **DHEA-S, DHEA, and androstenedione can be considered prehormones because they have little or no intrinsic androgenic activity and require conversion to testosterone to exert androgenic effects.** DHEA-S is produced almost exclusively by the adrenal glands, at a rate ranging between 3.5 and 20 mg/day<sup>3</sup>; the normal serum concentration is 100–350 µg/dL in most laboratories. DHEA is produced by both the adrenals (50%) and the ovaries (20%) and from the peripheral conversion of DHEA-S (30%). The production rate of DHEA is between 6 and 8 mg/day,<sup>6</sup> and normal serum concentrations range between 1 and 10 ng/mL. Androstenedione production is divided equally between the ovaries and the adrenals; the production rate is between 1.4 and 6.2 mg/day and the normal serum concentration is 0.5–2.0 ng/mL.<sup>7,8</sup> Serum immunoassays for DHEA-S, DHEA, and androstenedione generally reflect the amount of biologically available hormone because none of the three is protein bound to any significant extent.

In women, testosterone production derives from the adrenals (25%), from the ovaries (25%), and from peripheral conversion of androstenedione (50%) (**Figure 13.4**). The production rate ranges between 0.1 and 0.4 mg/day, and the normal serum concentration is 20–80 ng/dL; levels do not fluctuate widely but are lowest during the early follicular phase and approximately 20% higher at midcycle.<sup>6</sup> Testosterone bioavailability and metabolism, relevance of the hepatic sex hormone-binding globulin for tissue effects of androgens, and changes in the ovarian androgen production and in circulating profile in the postmenopausal period are discussed in **Chapter 12**. Adrenal androgen production is recognized to progressively decline with advancing age regardless of menopausal state; serum DHEA concentrations in women between ages 40 and 50 years are approximately half those in younger women.





**FIGURE 13.4**

Cells of the adrenal medulla are entirely distinct, both functionally and developmentally, from the cortex. The adrenal medulla is responsible for the production of catecholamines, norepinephrine and epinephrine, which play critical roles in regulating cardiovascular and renal systems. Although any major systemic disorder will ultimately affect reproductive function, disorders of the adrenal medulla are less likely to manifest as reproductive dysfunction and therefore will not be further discussed in this chapter.

# Adrenal Cortical Disorders Relevant to Female Reproduction

## Congenital Adrenal Hyperplasia (CAH)

Congenital adrenal hyperplasia (CAH) includes a group of autosomal recessive inherited endocrine disorders that are characterized by impaired cortisol synthesis due to inherited deficiencies in certain steroidogenic pathway enzymes.<sup>9,10,11,12,13,14,15,16,17,18</sup> Varying degrees of adrenal androgen excess are a hallmark. Clinical presentation is dictated by the severity of enzyme deficiency (and hence degree of cortisol deficiency) and consequent severity of androgen excess. Females with classical CAH (Table 13.1) usually are recognized at birth or during early infancy due to ambiguous appearance of genitalia (discussed in Chapter 8).<sup>11</sup> The nonclassical form of CAH (NCCAH, also known as late-onset CAH), however, tends to manifest later, with stigmata that are often subtle. NCCAH can present as premature adrenarche or precocious puberty (discussed in Chapter 9) and are often misdiagnosed as PCOS due to accompanying symptoms of hyperandrogenism (hirsutism and/or acne) and irregular menses (discussed in Chapter 11).<sup>19,20,21,22,23,24,25</sup> Data from neonatal screening programs for detection of classical CAH indicate that the overall prevalence of classical CAH is approximately 1 in 10,000 to 1 in 15,000 live births and varies with ethnicity. Among different races, the prevalence reportedly ranges from 1 in 28,000 Chinese<sup>26</sup> to between 1 in 5,000 and 1 in 23,000 Caucasians,<sup>27,28</sup> to as high as 1 in 280 Yupik Eskimos.<sup>29</sup> In the United States, the reported prevalence of classical CAH is 1 in 15,500 White and 1 in 42,000 African Americans.<sup>30</sup> In contrast to the general population, the prevalence of NCCAH among American White and Hispanic women with evidence of hyperandrogenism is higher, reported between 1% and 4%.<sup>14</sup> In other countries, prevalence has ranged from as low as 0.3% among Northern Italians to as high as 6–10% among women from Israel, India, and Jordan.<sup>15,16</sup> In different studies, the prevalence of nonclassical CAH has ranged between 1% and 15%.<sup>14,15,16,17</sup>

### TABLE 13.1 Congenital Adrenal Hyperplasia: Common Genetic Variants

Enzymatic Defects for Common CAH Variants	Affected Gene	Phenotype	Endocrine Hallmarks
21-Hydroxylase deficiency (most common cause of CAH)	CYP21A2	<p><b>Classic</b> (severe deficiency)</p> <ul style="list-style-type: none"> <li>• <b>Salt wasting accounts for 75% of cases:</b> Ambiguous genitalia in genetic female child, rapid-onset adrenal insufficiency in the first few weeks of neonatal life</li> <li>• <b>Simple virilizing (less severe deficiency)</b> <ul style="list-style-type: none"> <li>◦ Postnatal virilization, pseudoprecocious puberty</li> </ul> </li> </ul> <p><b>Nonclassic (least severe deficiency)</b></p> <ul style="list-style-type: none"> <li>• Hyperandrogenism during childhood, early activation of HPA and HPO axes (early adrenarche, early or precocious puberty)</li> <li>• May present a PCOS-like picture</li> <li>• May be asymptomatic</li> </ul>	<p>Elevated 17OHP (&gt;800 ng/dL)</p> <p>Elevated DHEA-S</p> <p>Elevated total testosterone</p> <p>Elevated ACTH</p> <p>As above (lesser degree of abnormalities)</p> <p>As above (lesser degree of abnormalities)</p> <p>ACTH may be in upper normal range</p>
11 $\beta$ -Hydroxylase deficiency (second most common cause of CAH)	CYP11B1	<p><b>Classic</b> (severe deficiency):</p> <ul style="list-style-type: none"> <li>• Ambiguous genitalia in genetic female child, postnatal virilization, hypertension</li> </ul> <p><b>Nonclassic (less severe deficiency)</b></p> <ul style="list-style-type: none"> <li>• Hyperandrogenism during childhood or early adulthood</li> <li>• Hypertension is common</li> <li>• May be asymptomatic</li> </ul>	<p>Elevated deoxycorticosterone</p> <p>Elevated deoxycortisol</p> <p>As above (lesser degree of abnormalities)</p>
3 $\beta$ -Hydroxysteroid dehydrogenase type 2 deficiency (least common cause of CAH)	HSD3B2	<p><b>Classic</b> (severe deficiency)</p> <ul style="list-style-type: none"> <li>• Ambiguous genitalia in both male and female infants, adrenal insufficiency and salt wasting in the first few weeks of neonatal life</li> </ul> <p><b>Nonclassic (less severe deficiency)</b></p> <ul style="list-style-type: none"> <li>• Hyperandrogenism during childhood or early adulthood</li> <li>• May be asymptomatic</li> </ul>	<p>Elevated DHEA-S</p> <p>Elevated 17OH pregnenolone</p> <p>Elevated 17OH pregnenolone to 17OH progesterone ratio (&gt;6 after ACTH stimulation test)</p>

The most common cause of both classical and nonclassical CAH is adrenal 21-hydroxylase (CYP21 or P450c21) deficiency caused by mutations in the CYP21A2 gene.<sup>12, 13, 14, 15, 16, 17, 18, 19, 20, 21, 22, 23, 24, 25, 26, 27</sup> The enzyme 21-hydroxylase is responsible for a critical step in the synthesis of both glucocorticoids and mineralocorticoids (see [Figure 13.3](#)), and its deficiency results in accumulation and overproduction of the precursor steroidogenic hormone 17 $\alpha$ -hydroxyprogesterone (17OHP). 17OHP represents a steroid metabolism intermediary, which not only is the substrate for 21-hydroxylase enzyme but also represents a critical precursor for both adrenal cortisol and androgen synthesis (see [Figure 13.3](#)). Deficiency of 21-hydroxylase accounts for the vast majority of cases of CAH (almost 90%). Deficiencies involving 11 $\beta$ -hydroxylase (second most common type of CAH caused by mutations in CYP11B1) occur in 1 in 100,000 live births in the general population and account for approximately 5% of cases of CAH. Deficiency of 3 $\beta$ -hydroxysteroid dehydrogenase

represents the least common type of CAH that results from mutations in the HSD3B gene. Regardless of the involved enzyme, the pathophysiology of CAH stems from decreased cortisol production, which stimulates a compensatory increase in pituitary ACTH secretion; the net results of chronic ACTH excess are adrenal hyperplasia and excessive levels of steroid hormones proximal to the enzyme block, which then seek an alternative metabolic pathway, resulting in increased production of androgens. These disorders are also reviewed in a context-specific manner in [Chapters 8, 9, 11, and 12](#). The severity of hormonal abnormalities depends on the degree of the enzymatic impairment, which depends on the genotype.<sup>31, 32, 33</sup> Compound heterozygotes for two different mutations usually have a phenotype compatible with the milder mutation ([Table 13.1](#)).

Females with classical CAH (both salt-wasting and simple virilizing forms) typically present at birth with ambiguous genitalia. In clinical settings with appropriate resources, cases of classic CAH in female newborns are likely to be diagnosed early given the abnormal appearing genitalia. Unless biochemically screened, this diagnosis will be missed in the male newborns who exhibit normal-appearing male genitalia. Unless diagnosed in a timely manner, infants with classic CAH have a poor prognosis due to rapid onset of electrolyte and fluid imbalance (salt wasting) due to deficiencies of both mineralocorticoids and glucocorticoids. In the United States and many other countries, routine screening of newborns is instituted to ensure a timely initiation of supplementation with the deficient hormones and consequent normalization of adrenal androgens.<sup>18, 28, 34</sup> In contrast to the classic variant, those with the NCCAH or “late-onset” form of CAH present later, during childhood or early adolescence with precocious puberty, or as young adults with signs of hyperandrogenism, very much like those with PCOS.<sup>18, 19, 20, 21, 22, 23, 24, 25</sup> **NCCAH must be considered in the differential diagnoses of all girls and women presenting with signs and symptoms of hyperandrogenism<sup>25</sup> and particularly so for those having an early onset of hirsutism (pre- or perimenarcheal, including girls with premature adrenarche), those with a family history of the disorder, and girls and women in high-risk ethnic groups presenting with features of androgen excess (Hispanic, Mediterranean, Slavic, Ashkenazi Jewish, or Yupik Eskimo heritage).**

Diagnostic yield from routine screening of CAH is very low, because the disorder is uncommon.<sup>2, 13, 35</sup> The importance of a prompt diagnosis of NCCAH lies in timeliness of interventions to help minimize severity of androgen excess–related symptoms and to ensure access to preconception genetic counseling given the heritable nature of this disorder. The diagnosis of NCCAH itself is unlikely to change the choice of recommended treatment. Inclusion of glucocorticoids in the management of NCCAH has been shown to effectively improve hyperandrogenemia through suppressing the ACTH

drive by negative feedback. The field however, has long shifted away from using glucocorticoids as a first-line approach and currently recommended management strategies aim at targeting the symptoms, for example, using combined hormonal contraceptives and antiandrogens to manage hirsutism. Glucocorticoids are less effective than estrogen-progestin contraceptives and/or antiandrogens for the treatment of chronic anovulation and hirsutism in women with NCCAH.<sup>36,37</sup>

## Androgen-Secreting Neoplasms of Adrenals


**Adrenal neoplasms** are a rare cause of androgen excess. The majority of these are malignant, although testosterone production has been described by some adrenal adenomas. In addition to androgens (DHEA, DHEA-S testosterone), cortisol excess may be seen.<sup>38</sup> Clinical presentation can be quite similar to that of ovarian androgen-secreting tumors (as discussed in [Chapter 12](#)).

## Cushing Syndrome

A disorder of cortisol excess, Cushing syndrome, can be confused with PCOS as symptoms of hyperandrogenism, such as hirsutism, as well as menstrual irregularities are often seen. **However, the prevalence of Cushing syndrome in women presenting with hyperandrogenism is extremely low, well below 1%.**<sup>2, 35, 39</sup>

One must be alerted to symptoms and signs of hypercortisolism, which, however, may vary with the duration and extent of excess cortisol secretion. In addition to hirsutism, the classical features of Cushing syndrome include progressive central obesity, excess fat accumulation in the cheeks (“moon face”) or at the back of the neck (“buffalo hump”), severe fatigue and muscle weakness, hypertension, atrophy of the skin, and subcutaneous tissue (easy bruising and purple striae on the abdomen and flanks).<sup>40</sup> Hyperpigmentation is also common<sup>41, 42</sup> and can be particularly prominent in cases of Cushing disease (caused by excess secretion of  $\alpha$ -melanocyte-stimulating hormone, a by-product of ACTH synthesis from proopiomelanocortin, the common precursor molecule) in areas most exposed to light (the face, neck, and back of the hands) or areas subject to chronic mild trauma, friction, or pressure (the elbows, knees, knuckles, and shoulders). Hypertension, diabetes, osteoporosis, and depression are common ([Table 13.2](#)).<sup>43, 44, 45, 46</sup>

### TABLE 13.2 Causes of Cortisol Excess



Iatrogenic (commonest cause)  
ACTH-driven cortisol excess (80%)  
    ACTH-secreting pituitary tumor (80%)  
        Adenomas  
        Carcinomas  
    Ectopic ACTH production (20%)  
ACTH independent  
    Autonomous adrenal overactivity (20%)  
Rare causes  
    Ectopic CRH release  
    Primary pigmented nodular adrenal disease  
    McCune-Albright syndrome

---

The clinical presentation of Cushing syndrome can also be caused by (1) long-term ingestion of prescribed glucocorticoids for chronic medical conditions, (2) an ACTH-secreting pituitary corticotroph adenoma (termed Cushing disease, accounting for most cases of cortisol excess), (3) cortisol-secreting adrenal adenomas and carcinomas, or (4) ectopic CRH or ACTH secretion by tumors (commonly bronchial carcinoids). The use of prescribed glucocorticoids (oral, rectal, inhaled, topical, or injected) is the most common cause of Cushing syndrome overall. **The first step in the evaluation of suspected Cushing syndrome is to exclude exogenous glucocorticoid exposure.**

# EVALUATION OF WOMEN WITH SUSPECTED ADRENAL DISORDERS

---

Gynecologists in general and reproductive endocrinologists in particular may be the first to encounter patients with adrenal disorders as menstrual dysfunction is a common initial presentation in reproductive-age women. Additionally, adrenal conditions that result in excessive production of glucocorticoids and/or androgens may mimic features of PCOS, the most common endocrine disorder of reproductive-age women. Gynecologists and reproductive endocrinologists therefore should be familiar with the initial screening process aimed at identifying the few who will benefit from prompt referral to endocrinologists for additional specific evaluation and definitive management. **As always, evaluation should begin with a careful history and physical examination, which always provide important diagnostic clues.** Laboratory investigation and imaging are used primarily to exclude other rare or potentially serious possibilities.

# HISTORY AND PHYSICAL EXAMINATION

---

Adrenal disorders should be considered in the differential diagnosis of any girl or woman presenting with features of androgen excess as well as menstrual irregularity. Similar to evaluation of hirsutism ([Chapter 12](#)), the key elements of the medical history in women with suspected adrenal disorders include the menstrual history, presence, timing of onset, and rate of progression of features of androgen excess (such as acne, hirsutism, hair loss, or features of virilization discussed in [Chapters 11 and 12](#)). Information on race and ethnicity and family history is particularly important when considering genetic disorders of an autosomal recessive inheritance, such as the nonclassical CAH.

Although the clinical presentation of nonclassical CAH can closely resemble that of PCOS, hirsutism tends to present earlier in life and be more severe in women with CAH often accompanied by history of early-onset adrenarche and precocious puberty.<sup>47,48</sup> A relatively short history and later age at onset of hirsutism (after age 25) or rapid progression over a period of months are highly concerning for an androgen-producing neoplasm. Symptoms of androgen excess (hirsutism, acne) if accompanied by progressive weight gain, easy bruising, and depressive symptoms should lead one to consider Cushing syndrome as a differential diagnosis.

A **family history** of hirsutism, menstrual irregularity, obesity, and infertility should raise concerns for possibility of nonclassical CAH, which is more common in women of Hispanic, Mediterranean, Slavic, or eastern European Jewish (Ashkenazi) heritage.

The **physical examination** should include attention to the general appearance with particular vigilance for signs and symptoms that can suggest a possibility of an underlying adrenal disorder. The classic descriptions of an excess glucocorticoid milieu include distinct physical features such as moon facies; buffalo hump and facial plethora; presence of wide cutaneous striae of purple hue along the anterior and lateral abdominal wall; proximal muscle weakness; evidence of hypertension, hyperglycemia, hypokalemia, and osteoporosis and tendency toward easy bruising and depression. Features of androgen excess due to nonclassical CAH are often confused with PCOS presentation, whereas signs of virilization (such as worsening hirsutism, male pattern baldness, clitoromegaly, deepening of voice, increasing libido, and changes in physique that include a regression in breast size and an increase in muscle mass) should alert one to the possibility of an underlying androgen-secreting tumor, particularly when the onset of symptoms is recent and progression is rapid (months and not years). Clitoral size varies significantly among women<sup>49</sup>; in one study, the mean length of the glans clitoris was  $5.1 \pm 1.4$  mm and the mean width was  $3.4 \pm 1.0$  mm.<sup>50</sup> Clitoromegaly generally is defined by a clitoral length greater than 10 mm or by a clitoral index (length times



width) greater than 35 mm<sup>2</sup>.<sup>51</sup> Other relevant physical findings include spontaneous or expressible galactorrhea, suggesting hyperprolactinemia (discussed in [Chapter 4](#)), and abdominal or pelvic masses that may represent an androgen-secreting tumor. As discussed in [Chapter 12](#), the modified **Ferriman-Gallwey score** is commonly utilized to quantify the severity of hirsutism.<sup>52</sup>

# LABORATORY EVALUATION

---

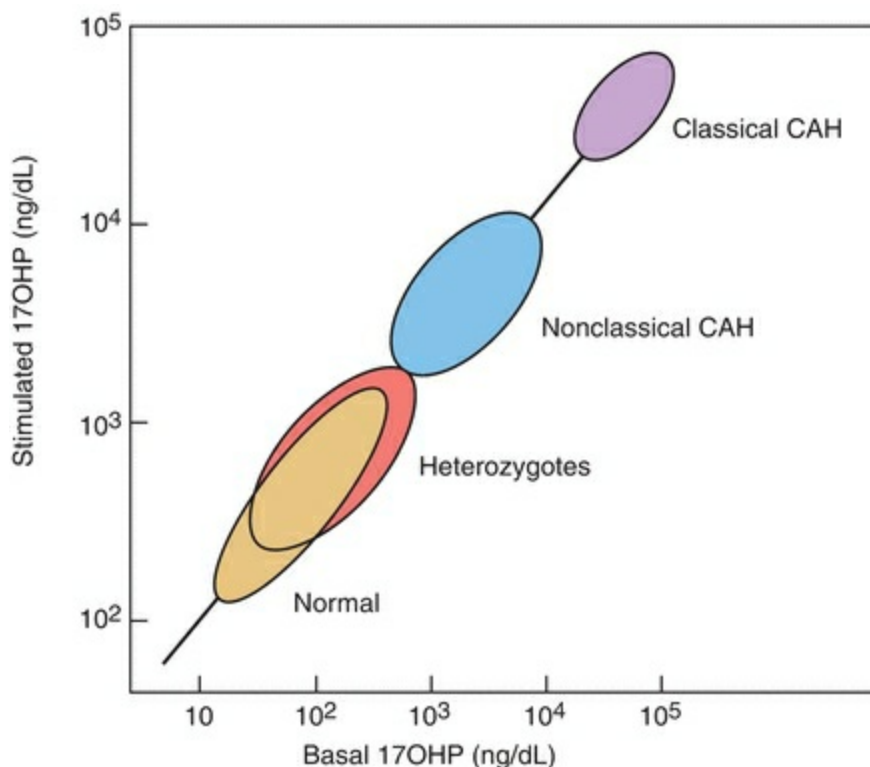
As discussed in [Chapter 12](#), the relationship between symptoms of hyperandrogenism such as hirsutism and circulating androgen concentrations is not entirely clear. The primary aim is to identify those having potentially serious endocrine disorders requiring specific treatment (nonclassical CAH, androgen-secreting tumors, Cushing syndrome). Thyroid disorders and hyperprolactinemia should be excluded in women with menstrual dysfunction. Elevated serum prolactin concentrations can be associated with increased serum DHEA-S levels,<sup>53</sup> prolactin receptors have been identified in the human adrenal, and prolactin can increase adrenal DHEA production in vitro.<sup>54</sup>

# Screening for Congenital Adrenal Hyperplasia

## Serum 17 $\alpha$ -Hydroxyprogesterone Concentration

In both normal women and those with NCCAH, the normal diurnal pattern of pituitary ACTH secretion is reflected in serum 17-hydroxyprogesterone (17OHP) concentrations, which peak in the morning and nadir late in the day. Morning serum 17OHP levels during the follicular phase of the menstrual cycle are clearly higher in women with NCCAH than in normal women, whereas evening concentrations may overlap significantly. **A follicular-phase morning serum 17OHP concentration less than 200 ng/dL (<2 ng/mL) effectively excludes the diagnosis of nonclassical CAH.**<sup>19,55,56</sup> Levels greater than 1,000 ng/dL (>10 ng/mL) are virtually diagnostic for 21-hydroxylase deficiency, and concentrations between 200 and 800 ng/dL (2–8 ng/mL) strongly suggest the diagnosis, which should be confirmed by performing an ACTH stimulation test.<sup>57</sup>

ACTH stimulation test is performed by obtaining blood samples before and 60 minutes after administering cosyntropin (synthetic ACTH 1–24, 0.25 mg intramuscularly or intravenously). **In most affected women, the response to ACTH stimulation is exaggerated, and the 17OHP level rises above 1,500 ng/dL (Figure 13.5).**<sup>17,55,56,58</sup>



## Genetic Screening

More than 95% of CAH cases are caused by mutations of the CYP21A2 that encodes 21-hydroxylase, a cytochrome P-450 type II enzyme of 495 amino acids.<sup>58</sup> The functioning CYP21A2 gene and its duplicated, but nonfunctional pseudogene (CYP21A1P), are both located on the short arm of chromosome 6 (band 6p21.3).<sup>59</sup> A variety of structural abnormalities ranging from deletions, gene duplications, rearrangements, substitutions, and point mutations to splicing mutations have been described to impact the enzyme activity, which in turn is a determinant of the degree of virilization.<sup>60,61,62,63,64,65,66</sup> Because of the high degree of sequence homology between CYP21A2 and its pseudogene, recombination occurs, and more than two-thirds of CYP21A2 disease-causing mutations are pseudogene-derived variants due to gene conversion, the transfer of deleterious pseudogene mutations to the active CYP21A2 gene.<sup>14</sup> De novo mutations in CYP21A2 that are not carried by either parent and uniparental disomy of chromosome 6 are rare mechanisms accounting for less than 2% of the cases.<sup>65,66</sup> Genotyping should be considered for confirming the diagnosis or elucidating a carrier state. Genotype correlates with disease severity, and the information provided is essential for preconception counseling. Heterozygote carriers exhibit lesser responses to ACTH stimulation that overlap with those of normal subjects,<sup>67</sup> (Figure 13.5).

## Diagnosis of Androgen-Producing Adrenal Tumor

### Hormones

**Testing for elevated androgen levels should begin with a serum total testosterone concentration.** Serum testosterone levels (normal 20–80 ng/dL) are elevated in most (70%), but not all, women with chronic anovulation and hirsutism. **A serum total testosterone concentration greater than 150 ng/dL identifies almost all women with a potential androgen-producing tumor.**<sup>68,69,70</sup> However, because serum testosterone concentrations can vary significantly in women with and without tumors, a tumor still should be suspected and excluded, in women with rapidly progressive hirsutism or signs or symptoms of virilization, even when the serum testosterone concentration is below the threshold value. DHEA-S circulates in higher concentration than any other steroid and derives almost exclusively from the adrenal gland. It is, therefore, a direct measure of adrenal androgen activity. The upper limit of normal in most laboratories is approximately 350 µg/dL, but ranges vary among laboratories. DHEA-S serves primarily as a prehormone, providing substrate for conversion to testosterone and henceforth to dihydrotestosterone in the periphery.

**Although the serum DHEA-S concentration would seem useful for identifying women with adrenal causes of hyperandrogenism, the test lacks both sensitivity and specificity for that purpose.** DHEA-S levels frequently are not grossly elevated in women with nonclassical CAH or Cushing syndrome and often are elevated in women with PCOS.<sup>71</sup> However, unlike NCCAH, the levels of ACTH are not elevated in women with PCOS.<sup>72,73</sup> **Serum DHEA-S concentration can be grossly elevated ( $\geq 700$   $\mu\text{g/dL}$ ) in women with rare androgen-secreting adrenal tumors. However, in almost all such patients, serum testosterone levels also are greatly elevated,<sup>74</sup> via peripheral conversion of high circulating DHEA-S levels or because the tumor also secretes testosterone. A serum DHEA-S concentration may be useful in women who's clinical presentation suggests strongly the possibility of a tumor, but the test otherwise has little or no clinical utility in the evaluation of hirsutism.**

**Adrenal CT (Computed Tomography) imaging is extremely sensitive for detecting the rare androgen-producing adrenal adenoma or carcinoma, and this step should be undertaken when a tumorous source for androgen excess is suspected and when pelvic examination and transvaginal ultrasonography fail to reveal an ovarian tumor.<sup>38</sup> Most androgen-secreting adrenal tumors are malignant.<sup>38,75,76</sup>** Adrenal adenomas typically are smaller (<4 cm in diameter) than carcinomas and have smooth borders and characteristically low unenhanced CT attenuation values; irregular margins, areas of necrosis, hemorrhage, or calcification suggest a carcinoma.<sup>77</sup> When needed, additional information to help define the nature of an adrenal mass lesion can be obtained by magnetic resonance imaging (MRI), by functional nuclear imaging with scintigraphy using a labeled cholesterol analog (<sup>131</sup>I-6-iodomethyl norcholesterol),<sup>78</sup> or by positron emission tomography (PET) scanning.

Findings of bilateral disease require further evaluation to distinguish among the causes, which include metastatic cancer (most commonly from the breast, kidney, or lung), adrenal hyperplasia (caused by long-term stimulation by pituitary or ectopic sources of ACTH and by rare forms of ACTH-independent macro- and micronodular disease),<sup>79,80</sup> infection (tuberculosis and fungal), hemorrhage, pheochromocytoma, and amyloidosis.

Routine adrenal imaging is not recommended and can be misleading, because nonfunctioning adrenal masses (incidentalomas) are common and their incidental detection demands additional, otherwise unnecessary, evaluation.<sup>81</sup> In autopsy studies, the prevalence of incidental adrenal adenomas approaches 10%.<sup>82,83</sup> In two case series of patients having abdominal CT scanning for a variety of indications, the prevalence of adrenal incidentaloma was 3–4%.<sup>84,85</sup>

Incidentally detected adrenal masses require evaluation to determine whether they

are functional; up to 15% secrete excess hormones, such as cortisol, catecholamines, and aldosterone.<sup>86</sup> The requisite tests include a 24-hour urine collection for fractionated metanephrines and catecholamines (pheochromocytoma), blood samples for fractionated metanephrines, testosterone and DHEA-S (adrenal carcinoma), plasma aldosterone and renin activity (primary aldosteronism), and an overnight dexamethasone suppression test (Cushing syndrome).<sup>81</sup> Fine-needle aspiration (FNA) biopsy may be indicated when there is reason to suspect a malignancy outside of the adrenal gland or in patients undergoing staging evaluation of a known cancer.<sup>83,87</sup> Although FNA is a relatively safe procedure, potential complications include adrenal hematoma and abscess, abdominal pain, hematuria, pancreatitis, and pneumothorax.<sup>88,89</sup> Because inadvertent FNA of a pheochromocytoma can precipitate an acute hypertensive crisis, the diagnosis always should be excluded by biochemical tests before FNA is performed.<sup>90</sup> When testing detects no evidence of hormone function and there is no reason to suspect a cancer, expectant management is appropriate; current recommendations include repeated imaging after 6, 12, and 24 months (to detect evidence of progressive growth) and repeated endocrine evaluation annually (to detect autonomous function not identified at baseline) for at least 4 years.<sup>81,91,92</sup>

## Diagnosis of Cushing Syndrome

**When symptoms of androgen excess are accompanied by distinct symptoms and signs of hypercortisolism, screening for Cushing syndrome is indicated.** However, because Cushing syndrome is rare, the risk of false-positive diagnostic tests is high. Widespread screening of overweight and obese women has a negligible yield and results in false-positive tests and needless anxiety.<sup>93</sup> Therefore, screening is best limited to individuals having a relatively high pretest probability of having the disorder. The currently recommended testing strategy is aimed at reducing the number of false-positive tests while using threshold values with high sensitivity to minimize false-negative results and emphasizes the most convenient and least costly tests.<sup>40</sup>

There are three methods of screening for Cushing syndrome that have comparable diagnostic accuracy<sup>94</sup>: the 24-hour urinary free cortisol excretion (measured twice), the late-night (11:00 P.M.–midnight) plasma or salivary cortisol level (measured twice), and the overnight dexamethasone suppression test.

The **24-hour urinary free cortisol excretion** provides a direct and reliable integrated measure of the serum free cortisol concentration.<sup>95,96</sup> Because a reliable 24-hour urine collection can be difficult to obtain, creatinine excretion should be measured in the same specimen to judge compliance with instructions. A systematic review and meta-analysis of diagnostic tests for Cushing syndrome reported a likelihood ratio of

10.6 (95% CI = 5.5–20.5) for an abnormal result and 0.16 (95% CI = 0.08–0.33) for a normal result (reflecting how the odds of the condition increase when the test is abnormal and decrease when the test is normal).<sup>94</sup> **Whereas values for 24-hour urinary free cortisol excretion greater than 3 times the upper normal limit are clearly abnormal, lower abnormal values are equivocal and more likely to represent a false-positive result.**<sup>97</sup> Patients must be instructed to avoid excessive fluid intake and the use of any products containing glucocorticoids during the collection. Because the hypercortisolism of Cushing syndrome can wax and wane, the test should be performed at least twice before judging the result.

The **late-night salivary cortisol level** is based on the fact that whereas serum cortisol levels normally peak at 7:00–9:00 A.M. and fall throughout the day to very low levels late at night, the normal circadian rhythm is lost in patients with Cushing syndrome.<sup>98,99</sup> Moreover, because free cortisol in the blood is in equilibrium with cortisol in saliva,<sup>100</sup> the late-night salivary cortisol (11:00 P.M.–midnight) level can be used to establish a diagnosis of Cushing syndrome.<sup>101,102,103,104,105</sup> Saliva is easy to collect by the patient at home, by passive drooling or after chewing on a cotton pledget for 1–2 minutes. Specimens are stable at room or refrigerator temperature for several weeks.<sup>40</sup> In contrast to salivary sex steroid hormone assays, salivary cortisol assays yield reliable results. Results are interpreted by comparison to established normal ranges, which vary among studies, probably due to differences in assays. The meta-analysis of diagnostic tests for Cushing syndrome reported a likelihood ratio of 9.5 (95% CI = 1.7–54.1) for an abnormal result and 0.09 (95% CI = 0.08–0.33) for a normal result.<sup>94</sup> Again, because the hypercortisolism of Cushing syndrome can fluctuate, the late-night cortisol level should be performed at least twice. Patients should be advised to avoid using licorice, chewing tobacco, and smoking, which may falsely elevate salivary cortisol levels. The method also probably is not the best choice for shift workers and those with bedtimes well after midnight.

The **overnight dexamethasone suppression test** is based on the concept that dexamethasone (a potent synthetic glucocorticoid) should suppress ACTH secretion by the normal pituitary gland, thereby also suppressing cortisol secretion. The test is performed by administering 1.0 mg of dexamethasone by mouth, between 11:00 P.M. and midnight and measuring the serum cortisol at 8:00 A.M. the next morning; values less than 1.8 µg/dL are normal.<sup>40</sup> The aforementioned systematic review and meta-analysis reported a likelihood ratio of 16.4 (95% CI = 9.3–28.8) for an abnormal result and 0.06 (95% CI = 0.03–0.14) for a normal result.<sup>94</sup> A 2-day low-dose dexamethasone suppression test also can be used (0.5 mg dexamethasone every 6 hours for a total of 8 doses beginning at 9:00 A.M. on day 1, with measurement of serum cortisol 6 hours after the last dose), applying the same criteria for normal suppression (<1.8 µg/dL).

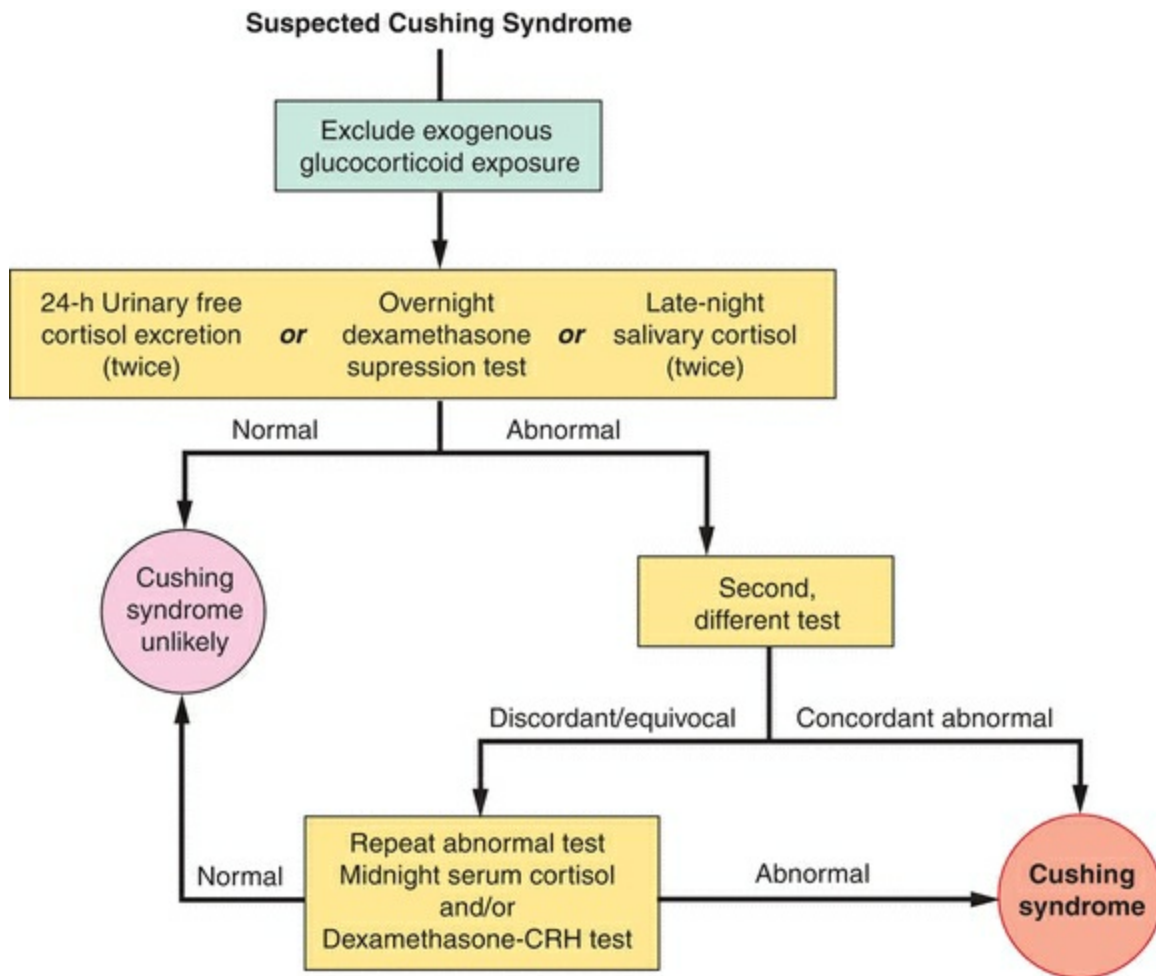
However, the 2-day test has lower diagnostic accuracy than the overnight test, with a likelihood ratio of 7.3 (95% CI = 3.6–15.2) for an abnormal result and 0.18 (95% CI = 0.06–0.52) for a normal result.<sup>94</sup> **Given its simplicity and ability to discriminate, the overnight dexamethasone suppression test is the best first test to perform when Cushing syndrome is suspected in patients with hirsutism.** Because estrogens increase the cortisol-binding globulin concentration and serum assays measure total cortisol, false-positive overnight dexamethasone test results are common in women using oral contraceptives.<sup>106</sup> Therefore, whenever possible, estrogen-containing drugs should be discontinued for 6 weeks before testing or retesting.<sup>107</sup>

**If the first screening test is normal, Cushing syndrome is excluded and no further testing is necessary, unless clinical suspicion (based on clinical presentation) is strong; re-evaluation in 6 months or sooner is indicated if symptoms or signs of Cushing syndrome progress. If the first test yields an abnormal result, a second, different, test should be performed. The diagnosis of Cushing syndrome is confirmed when two different tests are unequivocally abnormal. Patients with discordant or equivocal test results require further evaluation.**<sup>40</sup>

When necessary, additional evaluation should begin by repeating the abnormal test. Expanded evaluation also should include a midnight serum cortisol concentration and/or the dexamethasone-CRH test.

The **midnight serum cortisol concentration** has the same rationale as the late-night salivary cortisol level. Although the test is difficult to perform, it can be useful when 24-hour urinary free cortisol excretion or the overnight dexamethasone suppression test is normal but clinical suspicion for Cushing syndrome is high. A sleeping midnight serum cortisol greater than 1.8  $\mu\text{g/dL}$  or an awake midnight value greater than 7.5  $\mu\text{g/dL}$  increases the probability of Cushing syndrome.<sup>108,109</sup> Conversely, when the clinical suspicion for Cushing syndrome is low, as in simple obesity, but 24-hour urinary free cortisol excretion or the overnight dexamethasone suppression test is mildly abnormal, a sleeping midnight serum cortisol less than 1.8  $\mu\text{g/dL}$  or awake value less than 7.5  $\mu\text{g/dL}$  effectively excludes Cushing syndrome.<sup>109</sup> The test has similar utility in patients receiving anticonvulsant medications, which can accelerate metabolism of dexamethasone, causing a false-positive overnight dexamethasone suppression test<sup>110</sup> (**Figure 13.6**).

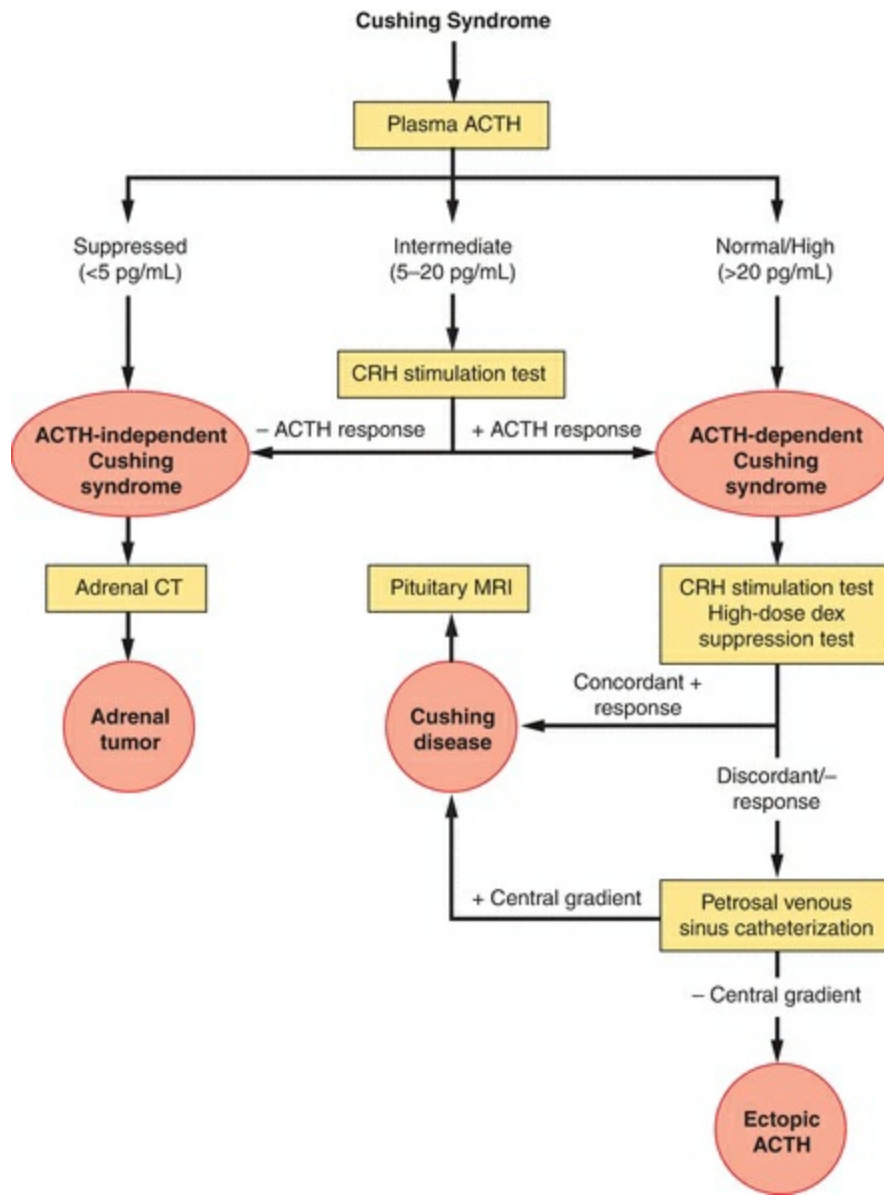




**FIGURE 13.6**

The **dexamethasone-CRH test** helps to differentiate patients with Cushing syndrome from those whose hypercortisolism relates to physical or psychological stress or depression (pseudo-Cushing syndrome).<sup>97</sup> The test is performed by administering dexamethasone 0.5 mg every 6 hours over 2 days for a total of 8 doses, administering CRH (1 µg/kg, intravenously) 2 hours after the last dose of dexamethasone, and measuring the serum cortisol 15 minutes later; in patients with pseudo-Cushing syndrome, values generally are less than 1.4 µg/dL.

## Establishing Cause of Cortisol Excess (Figure 13.7)



**FIGURE 13.7**

Once the diagnosis of Cushing syndrome is made, its cause must be determined. The tests used for diagnosis of Cushing syndrome cannot distinguish between pituitary, adrenal, and other causes of the disorder, because normal pituitary corticotrophs behave and respond in much the same way as a corticotroph adenoma. **The evaluation required to establish the cause of Cushing syndrome can be challenging and complicated and is best conducted by an endocrinologist having the necessary training and experience.**

The first step in the process is to measure the **plasma ACTH concentration**, to determine whether the hypercortisolism is ACTH dependent (due to an ACTH-secreting tumor) or ACTH independent (due to a primary adrenal source). The best ACTH test is

a two-site immunoradiometric assay.<sup>111</sup> Although plasma ACTH levels normally exhibit a circadian rhythm (20–80 pg/mL at 8:00 A.M., falling to <20 pg/mL at 4:00 P.M. and to <10 pg/mL within an hour after the usual time of falling asleep), ACTH can be measured at any time in patients with hypercortisolism, because the normal circadian rhythm is lost. At least two measurements should be obtained. Values less than 5 pg/mL indicate ACTH-independent disease,<sup>112</sup> and values greater than 20 pg/mL indicate ACTH-dependent disease. Values in between are less easily interpreted but usually are associated with ACTH-dependent disease; in such unusual cases, a CRH stimulation test can help steer evaluation in the right direction.

The **CRH stimulation test** (described below) is based on the fact that plasma ACTH and serum cortisol concentrations increase promptly after CRH stimulation in most patients with an ACTH-secreting pituitary adenoma, but not in those with a primary adrenal source, because pituitary ACTH secretion is suppressed.<sup>113,114,115,116,117</sup> An ACTH response to CRH stimulation thus indicates ACTH-dependent Cushing syndrome, and the lack of response indicates ACTH-independent disease.<sup>80,118</sup>

## **ACTH-Independent Cushing Syndrome**

For patients with ACTH-independent Cushing syndrome, the workup follows as described earlier under section “Diagnosis for androgen secreting adrenal tumors”. A **thin-section computed tomography (CT)** imaging of the adrenal glands should be considered as first line approach, seeking to identify an adrenal mass. If imaging reveals a unilateral adrenal adenoma, no further testing is necessary, and patient should be referred to an endocrine surgeon for definitive management. Findings suggesting a possible carcinoma require additional evaluation to stage the suspected cancer. Whereas most benign cortisol-secreting adenomas produce relatively little androgens, most androgen-secreting adrenal tumors are malignant.<sup>75,76</sup> Findings of bilateral disease also require further evaluation to determine whether bilateral masses are both functional or if one is a nonfunctional incidentaloma or to distinguish among the various causes of bilateral adrenal hyperplasia, which include long-term adrenal stimulation by pituitary or ectopic sources of ACTH and rare forms of ACTH-independent macro- and micronodular disease.<sup>79,80</sup>

## **ACTH-Dependent Cushing Syndrome**

For patients with ACTH-dependent Cushing syndrome, evaluation is aimed at identifying the source of ACTH secretion. By far, most such patients will have a pituitary corticotroph adenoma (Cushing disease). Ectopic ACTH-secreting or CRH-secreting tumors are rare.

The **CRH stimulation test** helps to distinguish pituitary from ectopic sources of

ACTH, for the same reason that it helps distinguish ACTH-dependent from ACTH-independent Cushing syndrome in women with equivocal plasma ACTH concentrations. ACTH and cortisol levels increase promptly after CRH stimulation in most patients with an ACTH-secreting pituitary adenoma, but not in those with ectopic sources of ACTH because pituitary ACTH secretion is suppressed.<sup>113,114,115,116,117</sup> After a period of fasting for 4 hours or more, blood samples are obtained 15 minutes and immediately before administering an intravenous bolus of synthetic ovine or human CRH (1 µg/kg or 100 µg total dose) and every 15 minutes for 60 minutes thereafter; samples are assayed for both ACTH and cortisol.<sup>114,115,116,117,118,119</sup> There are no established uniform criteria for interpretation of the CRH stimulation test in patients with Cushing syndrome. In various studies, a 35–50% increase in ACTH and a 20–50% increase in cortisol over basal concentrations excluded all patients with ectopic ACTH secretion and correctly identified over 90% of patients with Cushing disease.<sup>113,114</sup> In approximately 8–10% of patients with Cushing disease, ACTH levels do not rise appreciably in response to CRH.<sup>120</sup>

The **high-dose dexamethasone suppression test** also helps to distinguish pituitary from ectopic sources of ACTH. The test is based on the fact that ACTH-secreting pituitary adenomas are only relatively resistant to negative feedback by glucocorticoids; low doses of dexamethasone do not suppress their ACTH secretion, but high doses typically do.<sup>121</sup> In contrast, ectopic sources of ACTH are completely resistant to glucocorticoid suppression because they are not controlled by feedback inhibitory mechanisms.<sup>122</sup> The overnight high-dose dexamethasone suppression test is easier to perform than the standard 2-day test (2 mg every 6 hours for a total of 8 doses) and has comparable sensitivity and specificity.<sup>123</sup> The test is performed by administering 8 mg of dexamethasone between 11:00 P.M. and midnight and measuring the serum cortisol level at 8:00 A.M. the next morning; the cortisol concentration is less than 5 mg/dL in most, but not all, patients with an ACTH-secreting pituitary adenoma (Cushing disease).<sup>124</sup> Alternatively, the morning serum cortisol on the days before and after dexamethasone treatment can be compared, with 50% or greater suppression indicating Cushing disease.<sup>123,125,126</sup>

Combined, results obtained with the CRH stimulation test and the high-dose dexamethasone suppression test point to the source of ACTH in most patients with ACTH-dependent Cushing syndrome. Those whose cortisol levels are suppressed by high-dose dexamethasone (positive test) and stimulated by CRH (positive test) almost certainly have a pituitary ACTH-secreting adenoma.<sup>127,128</sup> Patients with discordant or negative test results are still more likely to have Cushing disease than ectopic ACTH secretion but require additional evaluation to establish the source of ACTH.

**Petrosal venous sinus catheterization** is the most direct way to demonstrate the

presence or absence of excessive pituitary ACTH secretion, by comparing the ACTH concentrations in the petrosal venous sinuses (draining the pituitary via the cavernous sinus) to that in the peripheral blood.<sup>129,130,131</sup> Blood samples are obtained from the petrosal sinuses and from a peripheral vein before and within 10 minutes after administration of CRH. A petrosal venous ACTH concentration twofold or greater than the peripheral venous concentration, or threefold or greater after CRH stimulation, distinguishes pituitary from ectopic sources of ACTH, with rare exceptions.<sup>120,132,133,134</sup> Some have reported that an ACTH concentration gradient between the two petrosal sinuses of 1.4 or greater can predict the location of the pituitary adenoma,<sup>120</sup> but others have found the measure unreliable.<sup>135,136</sup> Petrosal venous sinus catheterization also has significant potential risks, including cerebrovascular accident, cranial nerve palsies, pulmonary embolus, and deep vein thromboses and hematomas. Therefore, the procedure is difficult to justify solely for the purpose of localizing a tumor.

**Pituitary MRI** (unenhanced and gadolinium-enhanced) is more sensitive than CT for detecting corticotroph adenomas but still identifies only about half of such tumors.<sup>137</sup> The imaging protocol (field of view and repetition time/echo time value) should be optimized for detection of corticotroph adenomas.<sup>138</sup> When results obtained with CRH stimulation and high-dose dexamethasone suppression support the diagnosis of Cushing disease and imaging demonstrates an obvious tumor (>6 mm), no further evaluation is required. When endocrine test results are discordant or negative, petrosal venous sinus catheterization generally is required to isolate the source of ACTH, although preliminary pituitary imaging to exclude an obvious tumor still is prudent, in order to avoid unnecessary petrosal sinus sampling and its attendant risks.

Ectopic ACTH-secreting tumors can be difficult to localize. Chest CT or MRI is the logical first step because that is where most such tumors (e.g., bronchial carcinoids) are found<sup>139</sup> (see **Figure 13.7**).

## Key Points: Evaluation of Adrenal Disorders

- Adrenal sources of androgen excess should be considered in women presenting with features of hyperandrogenism.
- Nonclassical CAH should be suspected, and excluded, in patients with an early onset of hirsutism (pre- or perimenarcheal, including those with a premature adrenarche), in women with a family history of the disorder, and those belonging to high-risk ethnic groups (Hispanic, Mediterranean, Slavic, and Ashkenazi Jewish heritage). Reproductive endocrinologists should be familiar with the hormones of steroidogenic pathway to be able to interpret data (**Table 13.3**), as

well as be familiar with the rationale and methodology of some tests ([Table 13.4](#)) that are often utilized in the evaluation of suspected adrenal disorders.

- Androgen-secreting adrenal tumor should be considered in the differential diagnosis if symptoms of androgen excess are of short duration, are severe, and are rapidly progressive, serum total testosterone level is greater than 150 ng/mL, and the ovaries appear unremarkable on imaging. Elevated serum DHEA-S levels identify adrenals as source of androgen excess.
- Cushing syndrome should be suspected, and excluded, in women with symptoms and signs of hypercortisolism ([Table 13.4](#)).

## **TABLE 13.3      Circulating      Steroid      Hormones, Interpretation and Considerations**

	Intervention	Testing	Normal Response	Interpretation
<b>Dexamethasone (Dex) suppression test (DST)</b>				
• Overnight DST	• Oral 1 mg Dex between 11 PM and midnight	• Plasma/serum cortisol (drawn between 8 and 9 A.M.)	Normal <1.8 µg/dL	Suppression of cortisol levels rules out Cushing syndrome or adrenal tumor as a cause for cortisol excess
• 2-d DST	• Oral Dex 500 µg every 6 h starting at 9 A.M. × 8 doses for a total dose of 2 mg	• Plasma/serum cortisol drawn 6 h after last dose	Normal <1.8 µg/dL	
<b>ACTH stimulation test</b>	250 µg of synthetic ACTH (Cortrosyn) given intramuscularly or intravenously	<ul style="list-style-type: none"> <li>• 0- and 60-min blood sampling for assessment of 17OP</li> <li>• Testing of other steroidogenic hormones can offer additional information in certain circumstances, such as DHEA-S, 17OHPreg, 11-deoxycortisol, and cortisol</li> </ul>	<ul style="list-style-type: none"> <li>• Patients with classic and NCCAH will have 17OHP values &gt;1000 ng/dL</li> <li>• &lt;1000 ng/dL excludes CAH</li> </ul>	<ul style="list-style-type: none"> <li>• Screening test for CAH</li> <li>• Ratio of 17OHPreg to 17OHP of &gt;6 on ACTH stimulation is suggestive of 3βHSD deficiency</li> <li>• Also used to screen for primary adrenal insufficiency when lower ACTH dose (1 µg) is suggested</li> </ul>

**TABLE 13.4 Commonly Utilized Provoked Tests in the Evaluation of Adrenal Disorders**

<b>Steroid Hormones</b>	<b>Interpretation</b>	<b>Considerations</b>
<b>17-Hydroxyprogesterone</b>	Elevated in CAH due to 21-hydroxylase and 11-hydroxylase deficiencies Baseline normal <2 ng/mL Baseline >10 ng/mL is diagnostic of CAH	May be elevated in periovulatory period Best assessed in early follicular phase of menstrual cycle Measure in morning
<b>17-Hydroxypregnenolone</b>	Elevated in CAH due to 3 $\beta$ -hydroxysteroid dehydrogenase deficiency	May be elevated in periovulatory period. Best assessed in the early follicular phase of menstrual cycle
<b>Total testosterone</b>	Level >150 ng/mL should raise concerns for androgen-secreting tumor	May be elevated in periovulatory period. Best assessed in the early follicular phase of menstrual cycle
<b>DHEA-S</b>	Almost entirely adrenal source	May be elevated in periovulatory period. Best assessed in the early follicular phase of menstrual cycle
<b>ACTH</b>	Elevated in all types of CAH Elevated in Cushing disease (>20 pg/mL) Suppressed in Cushing syndrome (<5 pg/mL)	Suppressed with iatrogenic glucocorticoid use Preferably drawn between 8 and 9 A.M.
<b>Cortisol</b>	Elevated in Cushing syndrome and disease May be normal in nonclassical CAH	Midnight plasma/serum cortisol >7.5 $\mu$ g/dL has 95% diagnostic accuracy for Cushing syndrome (normally cortisol levels are lowest at midnight and peak in between 7 and 9 A.M.) Midnight salivary cortisol thresholds vary by assay Integrated 24-h urine free cortisol (UFC)
<b>11-Deoxycortisol</b>	May be elevated in CAH due to 11- $\beta$ hydroxylase deficiency	Hypertension is often encountered in cases of CAH due to 11- $\beta$ hydroxylase deficiency

17OHP, 17-hydroxyprogesterone; 17OHPreg, 17-hydroxypregnenolone; Dex, dexamethasone; DST, dexamethasone suppression test; ACTH, adrenocorticotropic hormone; CAH, congenital adrenal hyperplasia; NCCAH, nonclassical or late-onset CAH.



# MANAGEMENT OF ADRENAL DISORDERS

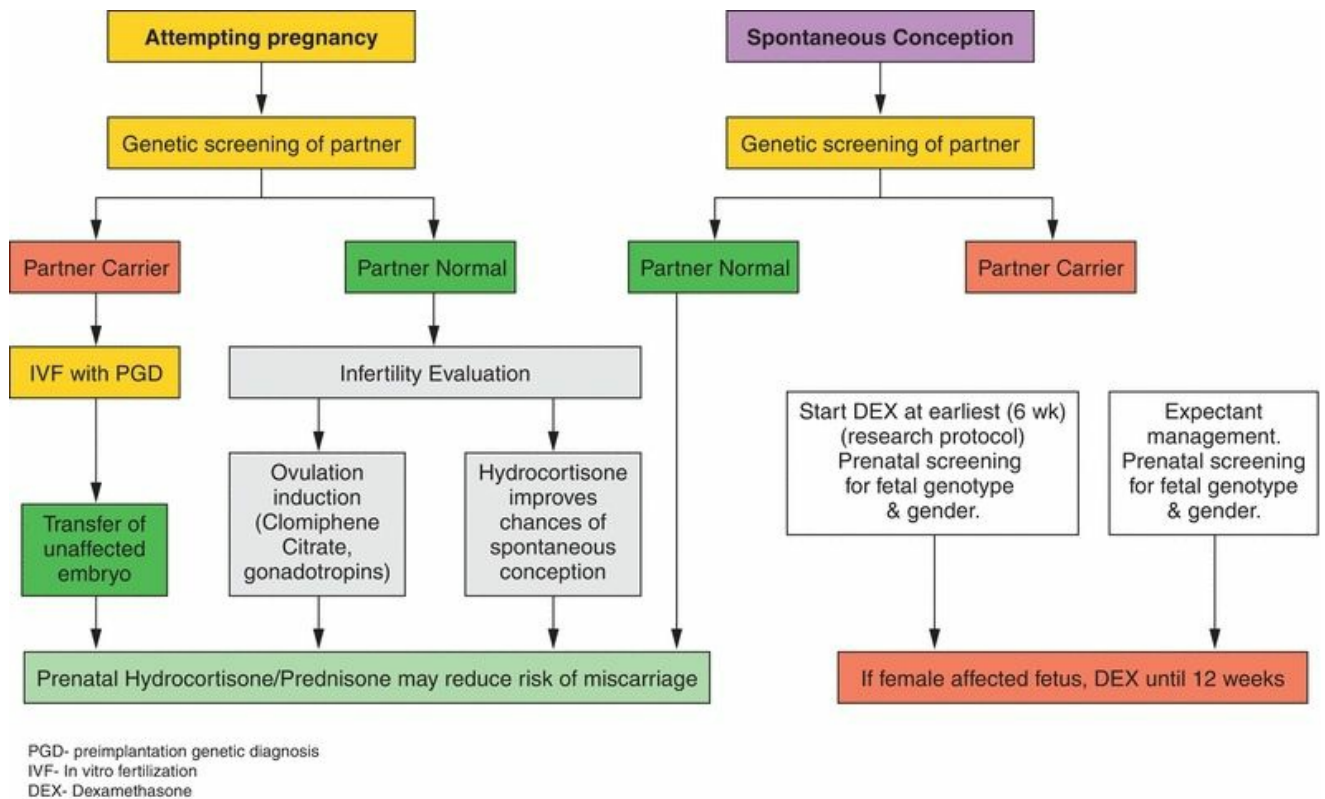
---

As mentioned at the start, our aim for including this chapter is not for gynecologists to practice endocrinology. Rather, our goal is to familiarize obstetricians, gynecologists, and reproductive endocrinologists with certain disorders of the adrenal gland where the presentation may mimic common gynecologic conditions. Glucocorticoids are used to suppress endogenous ACTH secretion in the long-term management of women with classical CAH, as well as for management of hirsutism in women with NCCAH, although with limited benefit. **While glucocorticoids suppress serum adrenal androgen levels effectively in women with NCCAH, they are less effective than oral contraceptives or antiandrogens for the treatment of hirsutism.**<sup>36,37</sup> Consequently, glucocorticoid treatment has even less to offer women with other causes for hirsutism.

# Unique Considerations

Girls and women with nonclassical CAH are likely to present to gynecologists for evaluation of menstrual dysfunction and symptoms of androgen excess, and providers should be alert to the possibility of nonclassical CAH as a differential diagnosis for this presentation. Particular vigilance is required of reproductive endocrinologists catering to fertility needs of women, as this differential diagnosis must be entertained and ruled out for patients presenting with features of chronic hyperandrogenism and ovulatory dysfunction. Given that nonclassical CAH can mimic PCOS (discussed in [Chapter 11](#)), a timely diagnosis and appropriate partner screening can mitigate the risk of conceiving a baby affected with classical CAH.

## Fertility and Pregnancy in Women at Risk for Conceiving CAH-Affected Child ([Figure 13.8](#))



**FIGURE 13.8**

### Infertility

Ovulatory disturbances are common in nonclassic forms of CAH, and fertility treatment,

either ovulation induction or assisted reproductive technology, may be required to achieve pregnancy, although spontaneous conceptions are well described.<sup>140,141,142,143,144</sup> Spontaneous ovulation is likely to resume with use of corticosteroids. Steroid-induced suppression of ACTH secretion with consequent suppression of the HPA axis and lowering of androgens and progesterone levels and thereby improved endometrial receptivity is an additional mechanism that could explain improved fertility rates described with the use of steroids in women with CAH.<sup>18,144,145</sup>

It is important to identify women at risk for conceiving a child with the more severe classical form of the disorder; the risk among women with hyperandrogenism is limited to those who carry one classic mutation and a variant allele associated with mild enzyme deficiency (compound heterozygotes), also having a male partner who carries an occult classic mutation. When both patient and partner are identified as genetic carriers of one of the common mutant genes or for women and couples with a prior CAH-affected child, judicious consideration of assisted reproductive technologies, such as in vitro fertilization (IVF) with preimplantation genetic diagnosis (PGD, also called preimplantation genetic testing for monogenic disorders, PGT-M), can virtually eliminate the risk of transmission of mutant genes to the next generation, and thereby eliminating the risk of a child affected by CAH.<sup>146,147</sup>

## **Fetal Risks and Risk Reduction**

If risk elimination through the use of IVF with PGD is not a feasible option, maternal supplementation with glucocorticoids that can reach the fetal circulation by crossing the placenta (such as dexamethasone) has been utilized as a strategy to reduce the risk of ambiguous genitalia in a CAH-affected female fetus.<sup>18,60,148,149,150</sup> The premise of this approach is based on assumptions that (1) the conceptus is homozygous for the mutant gene (CYP21 being the commonest) and (2) is a genetic female. Among women diagnosed with nonclassic CAH, the probability of conceiving an affected child is much higher than in the general population. Assuming a population prevalence of heterozygosity for severe CYP21A2 mutations at 1:60 and assuming that almost ½ of the women with the nonclassic CAH are actually compound heterozygotes (carrying a combination of one severe and one mild), the likelihood of women with nonclassic CAH for having a CAH-affected child is calculated at 1:480, which is dramatically higher than the risk in the general population (1:12,000–1:23,000 or even higher).<sup>13,142</sup> In an affected fetus, the specific steroidogenic enzyme deficiency (21-hydroxylase being the commonest) causes a reduction in fetal cortisol production, which in turn results in an up-regulation in fetal ACTH production through suppression of negative feedback (see **Figure 13.2**). The resulting high levels of fetal ACTH strive to stimulate the steroidogenic pathway in attempts to achieve normal cortisol levels; this perpetual stimulation of the steroidogenic pathway results in shunting of steroid precursors

proximal to the enzymatic block toward androgen production (**Figure 13.3**), resulting in hyperandrogenemia within the fetal compartment. The role of androgens in the development of normal and abnormal sexual development is discussed in **Chapter 8**. Given that it is cortisol deficiency that serves as the prime mechanism for HPA axis overdrive in pregnancies affected by CAH, by increasing fetal cortisol levels through maternal supplementation with a glucocorticoid that can cross the placenta without being metabolized (such as dexamethasone-DEX), down-regulation of fetal ACTH and thereby normalization of fetal androgen levels are achievable. Proponents of this approach recommend utilization of this approach from earliest knowledge of pregnancy (by 6 weeks at the latest) until the fetal gender can be determined using prenatal genetic screening (discussed in detail in **Chapter 31**).<sup>151,152,153,154,155,156</sup> Maternal supplementation can be safely discontinued for male fetuses as high androgen levels confer no risk of deformity of male external genitalia. If the affected fetus is genetically female, maternal supplementation within the first 8–12 weeks of gestation, when the external genitalia are differentiating, can reduce the risk as well as magnitude of virilization and thereby, future need for reconstructive surgery. Using a similar rationale, maternal use of corticosteroids through the course of pregnancy is described as a strategy to prevent fetal virilization. Available data on maternal glucocorticoid use to prevent fetal virilization thus far are entirely observational and comparative, and in recent years, the practice of maternal supplementation with corticosteroids has been placed in question, particularly given the lack of long-term safety data. Consensus by a number of professional societies including the Endocrine Society is that maternal supplementation with corticosteroids for fetal benefit be considered experimental, studies be conducted under purview of institutional review boards, and long-term surveillance of in utero steroid-treated children be prioritized.<sup>18</sup> Prenatal utilization of corticosteroids for fetal benefit in cases of CAH represents an off-label use of this class of drugs. Women with nonclassical CAH are deemed at a higher risk for spontaneous miscarriage compared to unaffected population, and this risk may be lower in women being treated with glucocorticoids in early pregnancy.<sup>18</sup> Glucocorticoid therapy may shorten time to pregnancy. Hydrocortisone and prednisone are preferred glucocorticoids for this indication as these get metabolized by placental 11 $\beta$ -hydroxysteroid dehydrogenase type 2, with minimal fetal exposure.

## Key Points

- Although management of adrenal endocrine disorders is deemed beyond the scope of practice of gynecologists, gynecologists must familiarize themselves with commoner adrenal disorders that may mimic PCOS, so as to ensure that patients

are appropriately referred for definitive care.

- Gynecologists should be familiar with screening tests for evaluation of common adrenal disorders such as CAH and Cushing syndrome (Tables 13.3 and 13.4) and be familiar with symptoms and signs that may suggest an underlying tumor as a mechanism for androgen excess symptoms.
- Rapidly progressive signs and symptoms of hyperandrogenism should alert clinician to possibility of an androgen-secreting tumor. If the ovaries appear normal on transvaginal ultrasound, adrenal glands as a source of androgen excess must be considered.
- Nonclassic congenital adrenal hyperplasia should be ruled out in young women manifesting features of androgen excess and menstrual irregularities.
- Late-onset CAH due to 11 $\beta$ -hydroxylase deficiency (second most common type of CAH) and Cushing syndrome should be considered when evaluating women with features of chronic hyperandrogenism and menstrual irregularities.
- Preconception genetic counseling should be made available to all girls/women as well as men who are diagnosed with CAH and prenatal genetic diagnosis used where feasible.
- In women with known NCCAH, prenatal use of corticosteroids (hydrocortisone/prednisone) in the first trimester may offer some benefit against risk of spontaneous miscarriage.
- Routine maternal treatment with dexamethasone to minimize risk of virilization in an affected female fetus is currently discouraged, except under research settings. If considered, treatment should be initiated at the earliest (around 6 weeks of gestation) and then continued until at least the completion of developmental stages of the external genitalia (around 12 weeks). Long-term follow-up of exposed children is recommended.

# REFERENCES

1. **O'Driscoll JB, Mamtora H, Higginson J, Pollock A, Kane J, Anderson DC**, A prospective study of the prevalence of clear-cut endocrine disorders and polycystic ovaries in 350 patients presenting with hirsutism or androgenic alopecia, *Clin Endocrinol (Oxf)* 41:231, 1994.
2. **Carmina E, Rosato F, Janni A, Rizzo M, Longo RA**, Extensive clinical experience: relative prevalence of different androgen excess disorders in 950 women referred because of clinical hyperandrogenism, *J Clin Endocrinol Metab* 91:2, 2006.
3. **Endoh A, Kristiansen SB, Casson PR, Buster JE, Hornsby PJ**, The zona reticularis is the site of biosynthesis of dehydroepiandrosterone and dehydroepiandrosterone sulfate in the adult human adrenal cortex resulting from its low expression of 3 beta-hydroxysteroid dehydrogenase, *J Clin Endocrinol Metab* 81:3558, 1996.
4. **Xing Y, Lerario A, Rainey W, Hammer GD**, Development of adrenal cortex zonation, *Endocrinol Metab Clin North Am* 44(2):243, 2015.
5. **Burger HG**, Androgen production in women, *Fertil Steril* 77(Suppl 4):S3, 2002.
6. **Longcope C**, Adrenal and gonadal androgen secretion in normal females, *Clin Endocrinol Metab* 15:213, 1986.
7. **Horton R, Tait JF**, Androstenedione production and interconversion rates measured in peripheral blood and studies on the possible site of its conversion to testosterone, *J Clin Invest* 45:301, 1966.
8. **Judd HL, Yen SS**, Serum androstenedione and testosterone levels during the menstrual cycle, *J Clin Endocrinol Metab* 36:475, 1973.
9. **White PC, New MI, Dupont B**, Congenital adrenal hyperplasia, *N Engl J Med* 316:1519, 1987.
10. **White PC, New MI, Dupont B**, Congenital adrenal hyperplasia, *N Engl J Med* 316:1580, 1987.
11. **New MI**, Female pseudohermaphroditism, *Semin Perinatol* 16:289, 1992.
12. **Moran C, Azziz R**, 21-hydroxylase-deficient nonclassic adrenal hyperplasia: the great pretender, *Semin Reprod Med* 21:295, 2003.
13. **White PC, Speiser PW**, Congenital adrenal hyperplasia due to 21-hydroxylase deficiency, *Endocr Rev* 21:245, 2000.
14. **Speiser PW, White PC**, Congenital adrenal hyperplasia, *N Engl J Med* 349:776, 2003.
15. **Azziz R, Dewailly D, Owerbach D**, Clinical review 56: nonclassic adrenal hyperplasia: current concepts, *J Clin Endocrinol Metab* 78:810, 1994.
16. **Speiser PW, Dupont B, Rubenstein P, Piazza A, Kastelan A, New MI**, High frequency of non-classical steroid 21-hydroxylase deficiency, *Am J Hum Genet* 37:650, 1985.
17. **Speiser PW**, Congenital adrenal hyperplasia owing to 21-hydroxylase deficiency, *Endocrinol Metab Clin North Am* 30:31, 2001.
18. **Carmina E, Dewailly D, Escobar-Morreale HF, Kelestimur F, Moran C, Oberfield S, Witchel SF, Azziz R**, Non-classic congenital adrenal hyperplasia due to 21-hydroxylase deficiency revisited: an update with a special focus on adolescent and adult women, *Hum Reprod Update* 23(5):580, 2017. doi:10.1093/humupd/dmx014.
19. **Azziz R, Zacur H**, 21-Hydroxylase deficiency in female hyperandrogenism: screening and diagnosis, *J Clin Endocrinol Metab* 69:577, 1989.
20. **Chetkowski RJ, DeFazio J, Shamonki I, Judd HL, Chang RJ**, The incidence of late-onset congenital adrenal hyperplasia due to 21-hydroxylase deficiency among hirsute women, *J Clin Endocrinol Metab* 58:595, 1984.
21. **Kuttann F, Couillin P, Girard F, Billaud L, Vincens M, Boucekkine C, Thalabard JC, Maudelonde T, Spritzer P, Mowszowicz I, et al.**, Late-onset adrenal hyperplasia in hirsutism, *N Engl J Med* 313:224, 1985.
22. **Dewailly D, Vantyghem MC, Lemaire C, Dufosse F, Racadot A, Fossati P**, Screening heterozygotes for 21-hydroxylase deficiency among hirsute women: lack of utility of the adrenocorticotropin hormone test, *Fertil Steril* 50:228, 1988.
23. **Pignatelli D**, Non-classic adrenal hyperplasia due to the deficiency of 21-hydroxylase and its relation to

- polycystic ovarian syndrome, *Front Horm Res* 40:158, 2013. doi:10.1159/000342179.
24. **Pall M, Azziz R, Beires J, Pignatelli D**, The phenotype of hirsute women: a comparison of polycystic ovary syndrome and 21-hydroxylase-deficient nonclassic adrenal hyperplasia, *Fertil Steril* 94(2):684, 2010. doi:10.1016/j.fertnstert.2009.06.025.
  25. **Escobar-Morreale HF, Sanchón R, San Millán JL**, A prospective study of the prevalence of nonclassical congenital adrenal hyperplasia among women presenting with hyperandrogenic symptoms and signs, *J Clin Endocrinol Metab* 93(2):527, 2008.
  26. **Lee HH, Kuo JM, Chao HT, Lee YJ, Chang JG, Tsai CH, Chung BC**, Carrier analysis and prenatal diagnosis of congenital adrenal hyperplasia caused by 21-hydroxylase deficiency in Chinese, *J Clin Endocrinol Metab* 85:597, 2000.
  27. **New MI, White PC**, Genetic disorders of steroid hormone synthesis and metabolism, *Baillieres Clin Endocrinol Metab* 9:525, 1995.
  28. **Cutfield WS, Webster D**, Newborn screening for congenital adrenal hyperplasia in New Zealand, *J Pediatr* 126:118, 1995.
  29. **Pang S, Murphey W, Levine LS, Spence DA, Leon A, LaFranchi S, Surve AS, New MI**, A pilot newborn screening for congenital adrenal hyperplasia in Alaska, *J Clin Endocrinol Metab* 55:413, 1982.
  30. **Therrell BL Jr, Berenbaum SA, Manter-Kapanke V, Simmank J, Korman K, Prentice L, Gonzalez J, Gunn S**, Results of screening 1.9 million Texas newborns for 21-hydroxylase-deficient congenital adrenal hyperplasia, *Pediatrics* 101:583, 1998.
  31. **Lee HH**, CYP21 mutations and congenital adrenal hyperplasia, *Clin Genet* 59(5):293, 2001.
  32. **Gurgov S, Bernabé KJ, Stites J, Cunniff CM, Lin-Su K, Felsen D, New MI, Poppas DP**, Linking the degree of virilization in females with congenital adrenal hyperplasia to genotype, *Ann N Y Acad Sci* 1402(1):56, 2017. doi:10.1111/nyas.13370.
  33. **New MI, Abraham M, Gonzalez B, Dunic M, Razzaghy-Azar M, Chitayat D, Sun L, Zaidi M, Wilson RC, Yuen T**, Genotype-phenotype correlation in 1,507 families with congenital adrenal hyperplasia owing to 21-hydroxylase deficiency, *Proc Natl Acad Sci U S A* 110(7):2611, 2013. doi:10.1073/pnas.1300057110.
  34. **Pang S, Wallace MA, Hofman L, Thuline HC, Dorche C, Lyon IC, Dobbins RH, Kling S, Fujieda K, Suwa S**, Worldwide experience in newborn screening for classical congenital adrenal hyperplasia due to 21-hydroxylase deficiency, *Pediatrics* 81:866, 1988.
  35. **Azziz R, Sanchez LA, Knochenhauer ES, Moran C, Lazenby J, Stephens KC, Taylor K, Boots LR**, Androgen excess in women: experience with over 1000 consecutive patients, *J Clin Endocrinol Metab* 89:453, 2004.
  36. **Spritzer P, Billaud L, Thalabard JC, Birman P, Mowszowicz I, Raux-Demay MC, Clair F, Kuttenn F, Mauvais-Jarvis P**, Cyproterone acetate versus hydrocortisone treatment in late-onset adrenal hyperplasia, *J Clin Endocrinol Metab* 70:642, 1990.
  37. **Frank-Raue K, Junga G, Raue F, Vecsei P, Ziegler R**, [Therapy of hirsutism in females with adrenal enzyme defects of steroid hormone biosynthesis: comparison of dexamethasone with cyproterone acetate], *Klin Wochenschr* 68:597, 1990.
  38. **Derksen J, Nagesser SK, Meinders AE, Haak HR, van de Velde CJ**, Identification of virilizing adrenal tumors in hirsute women, *N Engl J Med* 331:968, 1994.
  39. **Moran C, Tapia MC, Hernandez E, Vazquez G, Garcia-Hernandez E, Bermudez JA**, Etiological review of hirsutism in 250 patients, *Arch Med Res* 25:311, 1994.
  40. **Nieman LK, Biller BM, Findling JW, Newell-Price J, Savage MO, Stewart PM, Montori VM**, The diagnosis of Cushing's syndrome: an endocrine society clinical practice guideline, *J Clin Endocrinol Metab* 93:1526, 2008.
  41. **Stratakis CA**, Skin manifestations of Cushing's syndrome, *Rev Endocr Metab Disord* 17(3):283, 2016.
  42. **Jabbour SA**, Cutaneous manifestations of endocrine disorders: a guide for dermatologists, *Am J Clin Dermatol* 4(5):315, 2003.
  43. **Carmina E, Chu MC, Longo RA, Rini GB, Lobo RA**, Phenotypic variation in hyperandrogenic women influences the findings of abnormal metabolic and cardiovascular risk parameters, *J Clin Endocrinol Metab*

90:2545, 2005.

44. **Warriner AH, Saag KG**, Glucocorticoid-related bone changes from endogenous or exogenous glucocorticoids, *Curr Opin Endocrinol Diabetes Obes* 20(6):510, 2013.
45. **Hermus AR, Smals AG, Swinkels LM**, et al., Bone mineral density and bone turnover before and after surgical cure of Cushing's syndrome, *J Clin Endocrinol Metab* 80(10):2859, 1995.
46. **Sonino N, Fallo F, Fava GA**, Psychosomatic aspects of Cushing's syndrome, *Rev Endocr Metab Disord* 11(2):95, 2010.
47. **Ghanny BA, Malhotra S, Kumta S, Kazachkova I, Homel P, Jacobson-Dickman E, Motaghedi R**, Should children with isolated premature adrenarche be routinely evaluated for non-classical congenital adrenal hyperplasia? *J Pediatr Endocrinol Metab* 29(3):351, 2016.
48. **Armengaud JB, Charkaluk ML, Trivin C, Tardy V, Bréart G, Brauner R, Chalumeau M**, Precocious pubarche: distinguishing late-onset congenital adrenal hyperplasia from premature adrenarche, *J Clin Endocrinol Metab* 94(8):2835, 2009.
49. **Lloyd J, Crouch NS, Minto CL, Liao LM, Creighton SM**, Female genital appearance: "normality" unfolds, *Br J Obstet Gynaecol* 112:643, 2005.
50. **Verkauf BS, Von Thron J, O'Brien WF**, Clitoral size in normal women, *Obstet Gynecol* 80:41, 1992.
51. **Tagatz GE, Kopher RA, Nagel TC, Okagaki T**, The clitoral index: a bioassay of androgenic stimulation, *Obstet Gynecol* 54:562, 1979.
52. **Ferriman D, Gallwey JD**, Clinical assessment of body hair growth in women, *J Clin Endocrinol Metab* 21:1440, 1961.
53. **Seppala M, Hirvonen E**, Raised serum prolactin levels associated with hirsutism and amenorrhoea, *Br Med J* 4:144, 1975.
54. **Glasow A, Breidert M, Haidan A, Anderegg U, Kelly PA, Bornstein SR**, Functional aspects of the effect of prolactin (PRL) on adrenal steroidogenesis and distribution of the PRL receptor in the human adrenal gland, *J Clin Endocrinol Metab* 81:3103, 1996.
55. **Azziz R, Hincapie LA, Knochenhauer ES, Dewailly D, Fox L, Boots LR**, Screening for 21-hydroxylase deficient nonclassic adrenal hyperplasia among hyperandrogenic women: a prospective study, *Fertil Steril* 72:915, 1999.
56. **Moran C, Azziz R, Carmina E, Dewailly D, Fruzzetti F, Ibañez L, Knochenhauer ES, Marcondes JA, Mendonca BB, Pignatelli D, Pugeat M, Rohmer V, Speiser PW, Witchel SF**, 21-Hydroxylase-deficient nonclassic adrenal hyperplasia is a progressive disorder: a multicenter study, *Am J Obstet Gynecol* 183:1468, 2000.
57. **Hawkins LA, Chasalow FI, Blethen SL**, The role of adrenocorticotropin testing in evaluating girls with premature adrenarche and hirsutism/oligomenorrhea, *J Clin Endocrinol Metab* 74:248, 1992.
58. **Fiet J, Gueux B, Gourmelen M, Kuttenn F, Vexiau P, Couillin P, Pham-Huu-Trung MT, Villette JM, Raux-Demay MC, Galons H**, et al., Comparison of basal and adrenocorticotropin-stimulated plasma 21-deoxycortisol and 17-hydroxyprogesterone values as biological markers of late-onset adrenal hyperplasia, *J Clin Endocrinol Metab* 66:659, 1988.
59. **Nebert DW, Nelson DR, Coon MJ**, et al., The P450 super family: update on new sequences, gene mapping, and recommended nomenclature, *DNA Cell Biol* 10:1, 1991.
60. **Merke DP, Nieman LK**, Diagnosis and treatment of nonclassic (late-onset) congenital adrenal hyperplasia due to 21-hydroxylase deficiency. UpToDate. September 16, 2014. <http://www.uptodate.com/contents/diagnosis-and-treatment-of-nonclassic-late-onset-congenital-adrenal-hyperplasia-due-to-21-hydroxylase-deficiency>
61. **Higashi Y, Yoshioka H, Yamane M**, et al., Complete nucleotide sequence of two steroid 21-hydroxylase genes tandemly arranged in human chromosome: a pseudogene and a genuine gene, *Proc Natl Acad Sci U S A* 83:2841, 1986.
62. **Speiser PW, Dupont J, Zhu D**, et al., Disease expression and molecular genotype in congenital adrenal hyperplasia due to 21-hydroxylase deficiency, *J Clin Invest* 90:584, 1992.
63. **New MI, Speiser PW**, Genetics of adrenal steroid 21-hydroxylase deficiency, *Endocr Rev* 7(3):331, 1986.



64. **Hannah-Shmouni F, Chen W, Merke DP**, Genetics of congenital adrenal hyperplasia, *Endocrinol Metab Clin North Am* 46(2):435, 2017.
65. **Tusie-Luna MT, White PC**, Gene conversions and unequal crossovers between CYP21 (steroid 21-hydroxylase gene) and CYP21P involve different mechanisms, *Proc Natl Acad Sci U S A* 92:10796, 1995.
66. **Parker EA, Hovanes K, Germak J, et al.**, Maternal 21-hydroxylase deficiency and uniparental isodisomy of chromosome 6 and X results in a child with 21-hydroxylase deficiency and Klinefelter syndrome, *Am J Med Genet A* 140:2236, 2006.
67. **Gutai JP, Kowarski AA, Migeon CJ**, The detection of the heterozygous carrier for congenital virilizing adrenal hyperplasia, *J Pediatr* 90:924, 1977.
68. **Friedman CI, Schmidt GE, Kim MH, Powell J**, Serum testosterone concentrations in the evaluation of androgen-producing tumors, *Am J Obstet Gynecol* 153:44, 1985.
69. **Surrey ES, de Ziegler D, Gambone JC, Judd HL**, Preoperative localization of androgen-secreting tumors: clinical, endocrinologic, and radiologic evaluation of ten patients, *Am J Obstet Gynecol* 158:1313, 1988.
70. **Waggoner W, Boots LR, Azziz R**, Total testosterone and DHEAS levels as predictors of androgen-secreting neoplasms: a populational study, *Gynecol Endocrinol* 13:394, 1999.
71. **Azziz R, Black V, Hines GA, Fox LM, Boots LR**, Adrenal androgen excess in the polycystic ovary syndrome: sensitivity and responsivity of the hypothalamic-pituitary-adrenal axis, *J Clin Endocrinol Metab* 83:2317, 1998.
72. **Chang RJ, Mandel FP, Wolfren AR, Judd HL**, Circulating levels of plasma adrenocorticotropin in polycystic ovary disease, *J Clin Endocrinol Metab* 54:1265, 1982.
73. **Stewart PM, Penn R, Holder R, Parton A, Ratcliffe JG, London DR**, The hypothalamo-pituitary-adrenal axis across the normal menstrual cycle and in polycystic ovary syndrome, *Clin Endocrinol (Oxf)* 38:387, 1993.
74. **Kamilaris TC, DeBold CR, Manolas KJ, Hoursanidis A, Panageas S, Yiannatos J**, Testosterone-secreting adrenal adenoma in a peripubertal girl, *JAMA* 258:2558, 1987.
75. **Moreno S, Montoya G, Armstrong J, Leteurtre E, Aubert S, Vantyghe MC, Dewailly D, Wemeau JL, Proye C**, Profile and outcome of pure androgen-secreting adrenal tumors in women: experience of 21 cases, *Surgery* 136:1192, 2004.
76. **Kamenicky P, Houdoin L, Ferlicot S, Salenave S, Brailly S, Droupy S, Meduri G, Sasano H, Suzuki T, Young J, Chanson P**, Benign cortisol-secreting adrenocortical adenomas produce small amounts of androgens, *Clin Endocrinol (Oxf)* 66:778, 2007.
77. **Blake MA, Kalra MK, Sweeney AT, Lucey BC, Maher MM, Sahani DV, Halpern EF, Mueller PR, Hahn PF, Boland GW**, Distinguishing benign from malignant adrenal masses: multi-detector row CT protocol with 10-minute delay, *Radiology* 238:578, 2006.
78. **Ilias I, Sahdev A, Reznik RH, Grossman AB, Pacak K**, The optimal imaging of adrenal tumours: a comparison of different methods, *Endocr Relat Cancer* 14:587, 2007.
79. **Swain JM, Grant CS, Schlinkert RT, Thompson GB, van Heerden JA, Lloyd RV, Young WF**, Corticotropin-independent macronodular adrenal hyperplasia: a clinicopathologic correlation, *Arch Surg* 133:541, 1998.
80. **Horvath A, Mericq V, Stratakis CA**, Mutation in PDE8B, a cyclic AMP-specific phosphodiesterase in adrenal hyperplasia, *N Engl J Med* 358:750, 2008.
81. **Young WF Jr**, Clinical practice. The incidentally discovered adrenal mass, *N Engl J Med* 356:601, 2007.
82. **Hedeland H, Ostberg G, Hokfelt B**, On the prevalence of adrenocortical adenomas in an autopsy material in relation to hypertension and diabetes, *Acta Med Scand* 184:211, 1968.
83. **Cook DM, Loriaux DL**, The incidental adrenal mass, *Am J Med* 101:88, 1996.
84. **Herrera MF, Grant CS, van Heerden JA, Sheedy PF, Ilstrup DM**, Incidentally discovered adrenal tumors: an institutional perspective, *Surgery* 110:1014, 1991.
85. **Bovio S, Cataldi A, Reimondo G, Sperone P, Novello S, Berruti A, Borasio P, Fava C, Dogliotti L, Scagliotti GV, Angeli A, Terzolo M**, Prevalence of adrenal incidentaloma in a contemporary computerized tomography series, *J Endocrinol Invest* 29:298, 2006.
86. **Mantero F, Terzolo M, Arnaldi G, Osella G, Masini AM, Ali A, Giovagnetti M, Opocher G, Angeli A**

A survey on adrenal incidentaloma in Italy. Study Group on Adrenal Tumors of the Italian Society of Endocrinology, *J Clin Endocrinol Metab* 85:637, 2000.

87. **Jhala NC, Jhala D, Eloubeidi MA, Chhieng DC, Crowe DR, Roberson J, Eltoum I**, Endoscopic ultrasound-guided fine-needle aspiration biopsy of the adrenal glands: analysis of 24 patients, *Cancer* 102:308, 2004.
88. **Welch TJ, Sheedy PF II, Stephens DH, Johnson CM, Swensen SJ**, Percutaneous adrenal biopsy: review of a 10-year experience, *Radiology* 193:341, 1994.
89. **Arellano RS, Harisinghani MG, Gervais DA, Hahn PF, Mueller PR**, Image-guided percutaneous biopsy of the adrenal gland: review of indications, technique, and complications, *Curr Probl Diagn Radiol* 32:3, 2003.
90. **Casola G, Nicolet V, vanSonnenberg E, Withers C, Bretagnolle M, Saba RM, Bret PM**, Unsuspected pheochromocytoma: risk of blood-pressure alterations during percutaneous adrenal biopsy, *Radiology* 159:733, 1986.
91. **Barzon L, Scaroni C, Sonino N, Fallo F, Paoletta A, Boscaro M**, Risk factors and long-term follow-up of adrenal incidentalomas, *J Clin Endocrinol Metab* 84:520, 1999.
92. **Bulow B, Jansson S, Juhlin C, Steen L, Thoren M, Wahrenberg H, Valdemarsson S, Wangberg B, Ahren B**, Adrenal incidentaloma—follow-up results from a Swedish prospective study, *Eur J Endocrinol* 154:419, 2006.
93. **Baid SK, Rubino D, Sinaii N, Ramsey S, Frank A, Nieman LK**, Specificity of screening tests for Cushing's syndrome in an overweight and obese population, *J Clin Endocrinol Metab* 94:3857, 2009.
94. **Elamin MB, Murad MH, Mullan R, Erickson D, Harris K, Nadeem S, Ennis R, Erwin PJ, Montori VM**, Accuracy of diagnostic tests for Cushing's syndrome: a systematic review and meta-analyses, *J Clin Endocrinol Metab* 93:1553, 2008.
95. **Crapo L**, Cushing's syndrome: a review of diagnostic tests, *Metabolism* 28:955, 1979.
96. **Mengden T, Hubmann P, Muller J, Greminger P, Vetter W**, Urinary free cortisol versus 17-hydroxycorticosteroids: a comparative study of their diagnostic value in Cushing's syndrome, *Clin Investig* 70:545, 1992.
97. **Yanovski JA, Cutler GB Jr, Chrousos GP, Nieman LK**, Corticotropin-releasing hormone stimulation following low-dose dexamethasone administration. A new test to distinguish Cushing's syndrome from pseudo-Cushing's states, *JAMA* 269:2232, 1993.
98. **Glass AR, Zavadil AP III, Halberg F, Cornelissen G, Schaaf M**, Circadian rhythm of serum cortisol in Cushing's disease, *J Clin Endocrinol Metab* 59:161, 1984.
99. **Refetoff S, Van Cauter E, Fang VS, Laderman C, Graybeal ML, Landau RL**, The effect of dexamethasone on the 24-hour profiles of adrenocorticotropin and cortisol in Cushing's syndrome, *J Clin Endocrinol Metab* 60:527, 1985.
100. **Read GF, Walker RF, Wilson DW, Griffiths K**, Steroid analysis in saliva for the assessment of endocrine function, *Ann N Y Acad Sci* 595:260, 1990.
101. **Raff H, Raff JL, Findling JW**, Late-night salivary cortisol as a screening test for Cushing's syndrome, *J Clin Endocrinol Metab* 83:2681, 1998.
102. **Putignano P, Toja P, Dubini A, Pecori Giraldi F, Corsello SM, Cavagnini F**, Midnight salivary cortisol versus urinary free and midnight serum cortisol as screening tests for Cushing's syndrome, *J Clin Endocrinol Metab* 88:4153, 2003.
103. **Papanicolaou DA, Mullen N, Kyrou I, Nieman LK**, Nighttime salivary cortisol: a useful test for the diagnosis of Cushing's syndrome, *J Clin Endocrinol Metab* 87:4515, 2002.
104. **Yaneva M, Mosnier-Pudar H, Dugue MA, Grabar S, Fulla Y, Bertagna X**, Midnight salivary cortisol for the initial diagnosis of Cushing's syndrome of various causes, *J Clin Endocrinol Metab* 89:3345, 2004.
105. **Viardot A, Huber P, Puder JJ, Zulewski H, Keller U, Muller B**, Reproducibility of nighttime salivary cortisol and its use in the diagnosis of hypercortisolism compared with urinary free cortisol and overnight dexamethasone suppression test, *J Clin Endocrinol Metab* 90:5730, 2005.
106. **Nickelsen T, Lissner W, Schoffling K**, The dexamethasone suppression test and long-term contraceptive treatment: measurement of ACTH or salivary cortisol does not improve the reliability of the test, *Exp Clin*

Endocrinol 94:275, 1989.

107. **Qureshi AC, Bahri A, Breen LA, Barnes SC, Powrie JK, Thomas SM, Carroll PV**, The influence of the route of oestrogen administration on serum levels of cortisol-binding globulin and total cortisol, *Clin Endocrinol (Oxf)* 66:632, 2007.
108. **Newell-Price J, Trainer P, Perry L, Wass J, Grossman A, Besser M**, A single sleeping midnight cortisol has 100% sensitivity for the diagnosis of Cushing's syndrome, *Clin Endocrinol (Oxf)* 43:545, 1995.
109. **Papanicolaou DA, Yanovski JA, Cutler GB Jr, Chrousos GP, Nieman LK**, A single midnight serum cortisol measurement distinguishes Cushing's syndrome from pseudo-Cushing states, *J Clin Endocrinol Metab* 83:1163, 1998.
110. **Ma RC, Chan WB, So WY, Tong PC, Chan JC, Chow CC**, Carbamazepine and false positive dexamethasone suppression tests for Cushing's syndrome, *Br Med J* 330:299, 2005.
111. **Raff H, Findling JW**, A new immunoradiometric assay for corticotropin evaluated in normal subjects and patients with Cushing's syndrome, *Clin Chem* 35:596, 1989.
112. **Invitti C, Pecori Giraldi F, de Martin M, Cavagnini F**, Diagnosis and management of Cushing's syndrome: results of an Italian multicentre study. Study Group of the Italian Society of Endocrinology on the Pathophysiology of the Hypothalamic-Pituitary-Adrenal Axis, *J Clin Endocrinol Metab* 84:440, 1999.
113. **Reimondo G, Paccotti P, Minetto M, Termine A, Stura G, Bergui M, Angeli A, Terzolo M**, The corticotrophin-releasing hormone test is the most reliable noninvasive method to differentiate pituitary from ectopic ACTH secretion in Cushing's syndrome, *Clin Endocrinol (Oxf)* 58:718, 2003.
114. **Nieman LK, Oldfield EH, Wesley R, Chrousos GP, Loriaux DL, Cutler GB Jr**, A simplified morning ovine corticotropin-releasing hormone stimulation test for the differential diagnosis of adrenocorticotropin-dependent Cushing's syndrome, *J Clin Endocrinol Metab* 77:1308, 1993.
115. **Tsagarakis S, Tsigos C, Vasiliou V, Tsiotra P, Kaskarelis J, Sotiropoulou C, Raptis SA, Thalassinos N**, The desmopressin and combined CRH-desmopressin tests in the differential diagnosis of ACTH-dependent Cushing's syndrome: constraints imposed by the expression of V2 vasopressin receptors in tumors with ectopic ACTH secretion, *J Clin Endocrinol Metab* 87:1646, 2002.
116. **Newell-Price J, Morris DG, Drake WM, Korbonits M, Monson JP, Besser GM, Grossman AB**, Optimal response criteria for the human CRH test in the differential diagnosis of ACTH-dependent Cushing's syndrome, *J Clin Endocrinol Metab* 87:1640, 2002.
117. **Pecori Giraldi F, Invitti C, Cavagnini F**, The corticotropin—releasing hormone test in the diagnosis of ACTH-dependent Cushing's syndrome: a reappraisal, *Clin Endocrinol (Oxf)* 54:601, 2001.
118. **Carney JA, Young WF Jr**, Primary pigmented nodular adrenocortical disease and its associated conditions, *Endocrinologist* 2:6, 1992.
119. **Sheldon WRJ, DeBold CR, Evans WS, DeCherney GS, Jackson RV, Island DP, Thorner MO, Orth DN**, Rapid sequential intravenous administration of four hypothalamic releasing hormones as a combined anterior pituitary function test in normal subjects, *J Clin Endocrinol Metab* 60:623, 1985.
120. **Oldfield EH, Doppman JL, Nieman LK, Chrousos GP, Miller DL, Katz DA, Cutler GB Jr, Loriaux DL**, Petrosal sinus sampling with and without corticotropin-releasing hormone for the differential diagnosis of Cushing's syndrome, *N Engl J Med* 325:897, 1991.
121. **Liddle GW**, Tests of pituitary-adrenal suppressibility in the diagnosis of Cushing's syndrome, *J Clin Endocrinol Metab* 20:1539, 1960.
122. **Liddle GW, Nicholson WE, Island DP, Orth DN, Abe K, Lowder SC**, Clinical and laboratory studies of ectopic humoral syndromes, *Recent Prog Horm Res* 25:283, 1969.
123. **Dichek HL, Nieman LK, Oldfield EH, Pass HI, Malley JD, Cutler GB Jr**, A comparison of the standard high dose dexamethasone suppression test and the overnight 8-mg dexamethasone suppression test for the differential diagnosis of adrenocorticotropin-dependent Cushing's syndrome, *J Clin Endocrinol Metab* 78:418, 1994.
124. **Aron DC, Raff H, Findling JW**, Effectiveness versus efficacy: the limited value in clinical practice of high dose dexamethasone suppression testing in the differential diagnosis of adrenocorticotropin-dependent Cushing's syndrome, *J Clin Endocrinol Metab* 82:1780, 1997.

125. **Bruno OD, Rossi MA, Contreras LN, Gomez RM, Galparsoro G, Cazado E, Kral M, Leber B, Arias D**, Nocturnal high-dose dexamethasone suppression test in the aetiological diagnosis of Cushing's syndrome, *Acta Endocrinol (Copenh)* 109:158, 1985.
126. **Tyrrell JB, Findling JW, Aron DC, Fitzgerald PA, Forsham PH**, An overnight high-dose dexamethasone suppression test for rapid differential diagnosis of Cushing's syndrome, *Ann Intern Med* 104:180, 1986.
127. **Nieman LK, Chrousos GP, Oldfield EH, Avgerinos PC, Cutler GB Jr, Loriaux DL**, The ovine corticotropin-releasing hormone stimulation test and the dexamethasone suppression test in the differential diagnosis of Cushing's syndrome, *Ann Intern Med* 105:862, 1986.
128. **Hermus AR, Pieters GF, Pesman GJ, Smals AG, Benraad TJ, Kloppenborg PW**, The corticotropin-releasing-hormone test versus the high-dose dexamethasone test in the differential diagnosis of Cushing's syndrome, *Lancet* 2:540, 1986.
129. **Doppman JL, Oldfield E, Krudy AG, Chrousos GP, Schulte HM, Schaaf M, Loriaux DL**, Petrosal sinus sampling for Cushing syndrome: anatomical and technical considerations. Work in progress, *Radiology* 150:99, 1984.
130. **Oldfield EH, Girton ME, Doppman JL**, Absence of intercavernous venous mixing: evidence supporting lateralization of pituitary microadenomas by venous sampling, *J Clin Endocrinol Metab* 61:644, 1985.
131. **Oldfield EH, Chrousos GP, Schulte HM, Schaaf M, McKeever PE, Krudy AG, Cutler GB Jr, Loriaux DL, Doppman JL**, Preoperative lateralization of ACTH-secreting pituitary microadenomas by bilateral and simultaneous inferior petrosal venous sinus sampling, *N Engl J Med* 312:100, 1985.
132. **Bonelli FS, Huston J III, Carpenter PC, Erickson D, Young WF Jr, Meyer FB**, Adrenocorticotropic hormone-dependent Cushing's syndrome: sensitivity and specificity of inferior petrosal sinus sampling, *AJNR Am J Neuroradiol* 21:690, 2000.
133. **Colao A, Faggiano A, Pivonello R, Pecori Giraldi F, Cavagnini F, Lombardi G**, Inferior petrosal sinus sampling in the differential diagnosis of Cushing's syndrome: results of an Italian multicenter study, *Eur J Endocrinol* 144:499, 2001.
134. **Ilias I, Torpy DJ, Pacak K, Mullen N, Wesley RA, Nieman LK**, Cushing's syndrome due to ectopic corticotropin secretion: twenty years' experience at the National Institutes of Health, *J Clin Endocrinol Metab* 90:4955, 2005.
135. **Tabarin A, Greselle JF, San-Galli F, Leprat F, Caille JM, Latapie JL, Guerin J, Roger P**, Usefulness of the corticotropin-releasing hormone test during bilateral inferior petrosal sinus sampling for the diagnosis of Cushing's disease, *J Clin Endocrinol Metab* 73:53, 1991.
136. **Lopez J, Barcelo B, Lucas T, Salame F, Alameda C, Boronat M, Salto L, Estrada J**, Petrosal sinus sampling for diagnosis of Cushing's disease: evidence of false negative results, *Clin Endocrinol (Oxf)* 45:147, 1996.
137. **Hall WA, Luciano MG, Doppman JL, Patronas NJ, Oldfield EH**, Pituitary magnetic resonance imaging in normal human volunteers: occult adenomas in the general population, *Ann Intern Med* 120:817, 1994.
138. **Chowdhury IN, Sinaï N, Oldfield EH, Patronas N, Nieman LK**, A change in pituitary MRI protocol detects ACTH-secreting tumours in patients with previously negative results, *Clin Endocrinol (Oxf)* 72:502, 2010.
139. **Pacak K, Ilias I, Chen CC, Carrasquillo JA, Whatley M, Nieman LK**, The role of [(18)F]fluorodeoxyglucose positron emission tomography and [(111)In]-diethylenetriaminepentaacetate-D-Pentetate scintigraphy in the localization of ectopic adrenocorticotropic-secreting tumors causing Cushing's syndrome, *J Clin Endocrinol Metab* 89:2214, 2004.
140. **Eyal O, Ayalon-Dangur I, Segev-Becker A, Schachter-Davidov A, Israel S, Weintrob N**, Pregnancy in women with nonclassic congenital adrenal hyperplasia: time to conceive and outcome, *Clin Endocrinol (Oxf)* 87(5):552, 2017.
141. **Moran C, Azziz R, Weintrob N, Witchel SF, Rohmer V, Dewailly D, Marcondes JA, Pugeat M, Speiser PW, Pignatelli D, Mendonca BB, Bachega TA, Escobar-Morreale HF, Carmina E, Fruzzetti F, Kelestimur F**, Reproductive outcome of women with 21-hydroxylase-deficient nonclassic adrenal hyperplasia, *J Clin Endocrinol Metab* 91(9):3451, 2006.

142. **Bidet M, Bellané-Chantelot C, Galand-Portier MB, Golmard JL, Tardy V, Morel Y, Clauin S, Coussieu C, Boudou P, Mowzowicz I, Bachelot A, Touraine P, Kuttenn F**, Fertility in women with nonclassical congenital adrenal hyperplasia due to 21-hydroxylase deficiency, *J Clin Endocrinol Metab* 95:1182, 2010.
143. **Hagenfeldt K, Janson PO, Holmdahl G, Falhammar H, Filipsson H, Frisé L, Thorén M, Nordenskjöld A**, Fertility and pregnancy outcome in women with congenital adrenal hyperplasia due to 21-hydroxylase deficiency, *Hum Reprod* 23:1607, 2008.
144. **Feldman S, Billaud L, Thalabard JC, Raux-Demay MC, Mowszowicz I, Kuttenn F, Mauvais-Jarvis P**, Fertility in women with late-onset adrenal hyperplasia due to 21-hydroxylase deficiency, *J Clin Endocrinol Metab* 74(3):635, 1992.
145. **Okon MA, Laird SM, Tuckerman EM, Li TC**, Serum androgen levels in women who have recurrent miscarriages and their correlation with markers of endometrial function, *Fertil Steril* 69:682, 1998.
146. **Altarescu G, Barenholz O, Renbaum P, Beerl R, Levy-Lahad E, Margalioth EJ, Brooks B, Varshaver I, Eldar-Geva T**, Preimplantation genetic diagnosis (PGD)—prevention of the birth of children affected with endocrine diseases, *J Pediatr Endocrinol Metab* 24(7-8):543, 2011.
147. **Van de Velde H, Sermon K, De Vos A, Lissens W, Joris H, Vandervorst M, Van Steirteghem A, Liebaers I**, Fluorescent PCR and automated fragment analysis in preimplantation genetic diagnosis for 21-hydroxylase deficiency in congenital adrenal hyperplasia, *Mol Hum Reprod* 5(7):691, 1999.
148. **Evans MI, Chrousos GP, Mann DW, Larsen JW Jr, Green I, McCluskey J, Loriaux DL, Fletcher JC, Koons G, Overpeck J, Schulman JD**, Pharmacologic suppression of the fetal adrenal gland in utero. Attempted prevention of abnormal external genital masculinization in suspected congenital adrenal hyperplasia, *JAMA* 253:1015, 1985.
149. **David M, Forest MG**, Prenatal treatment of congenital adrenal hyperplasia resulting from 21-hydroxylase deficiency, *J Pediatr* 105:799, 1984.
150. **Forest MG, Morel Y, David M**, Prenatal treatment of congenital adrenal hyperplasia, *Trends Endocrinol Metab* 9:284, 1998.
151. **Speiser PW, Laforgia N, Kato K, Pareira J, Khan R, Yang SY, Whorwood C, White PC, Elias S, Schriock E, Simpson JL, Taslimi M, Najjar J, May S, Mills G, Crawford C, New MI**, First trimester prenatal treatment and molecular genetic diagnosis of congenital adrenal hyperplasia (21-hydroxylase deficiency), *J Clin Endocrinol Metab* 70:838, 1990.
152. **New MI, Carlson A, Obeid J, Marshall I, Cabrera MS, Goseco A, Lin-Su K, Putnam AS, Wei JQ, Wilson RC**, Prenatal diagnosis for congenital adrenal hyperplasia in 532 pregnancies, *J Clin Endocrinol Metab* 86:5651, 2001.
153. **Ma D, Yuan Y, Luo C, Wang Y, Jiang T, Guo F, Zhang J, Chen C, Sun Y, Cheng J, Hu P, Wang J, Yang H, Yi X, Wang W, Asan, Xu Z**, Noninvasive prenatal diagnosis of 21-Hydroxylase deficiency using target capture sequencing of maternal plasma DNA, *Sci Rep* 7(1):7427, 2017.
154. **New MI, Tong YK, Yuen T, Jiang P, Pina C, Chan KC, Khattab A, Liao GJ, Yau M, Kim SM, Chiu RW, Sun L, Zaidi M, Lo YM**, Noninvasive prenatal diagnosis of congenital adrenal hyperplasia using cell-free fetal DNA in maternal plasma, *J Clin Endocrinol Metab* 99(6):E1022, 2014. doi:10.1210/jc.2014-1118.
155. **Motaghedi R, Betensky BP, Slowinska B, Cerame B, Cabrer M, New MI, Wilson RC**, Update on the prenatal diagnosis and treatment of congenital adrenal hyperplasia due to 11beta-hydroxylase deficiency, *J Clin Endocrinol Metab* 99(6):E1022, 2014. doi:10.1210/jc.2014-1118.
156. **Mao R, Nelson L, Kates R, Miller CE, Donaldson DL, Tang W, Ward K**, Prenatal diagnosis of 21-hydroxylase deficiency caused by gene conversion and rearrangements: pitfalls and molecular diagnostic solutions, *Prenat Diagn* 22(13):1171, 2002.

# Menstruation-Related Disorders

Since antiquity, the temporal relationship between menses and the lunar phases has inspired names for menstruation, such as the “period.” The regularity of menses was easily appreciated by the ancients, even if they had no understanding of its cause or purpose. Ancient physicians viewed menstruation as a process of detoxification, and throughout history, myths and superstitions have perpetuated negative attitudes toward menses.<sup>1</sup>

The health care profession has an obligation to provide and to promote education on menstruation and related subjects. Clinicians must have a thorough understanding of reproductive physiology before they can impart that knowledge to their patients and must be sensitive to the need to present the information in a positive and culturally appropriate context that fosters healthy attitudes toward sexual and reproductive functions. An educated understanding of normal reproductive processes is a powerful tool for addressing the symptoms and disorders of menstruation.

Some menstrual disorders, such as dysmenorrhea, can be explained in a physiologic framework that both educates and provides the foundation for appropriate treatment. Unfortunately, others, such as the premenstrual syndrome (PMS), still remain relatively poorly understood. **This chapter considers several medical problems that are temporally linked with menstruation** and their pathophysiology when that is known.

# HISTORICAL VIEWS OF MENSTRUATION AND MENSTRUATING WOMEN

---

Recorded history includes a wide variety of myths regarding menstruation and menstruating women. In ancient times, menstruating women commonly were thought possessed by an evil spirit. Aristotle (384–322 B.C.), the Greek philosopher, student of Plato, and teacher of Alexander the Great, said that a menstruous woman could dull a mirror with a look and that the next person to peer into it would be bewitched. Pliny, born in 23 A.D., consulted approximately 2,000 available books by physicians while writing his treatise, *Historia Naturalis*, a resource used throughout the Dark Ages; more than a hundred copies, all 37 volumes, still exist. Pliny wrote extensively on menstruation, including the following<sup>2</sup>:

Contact with it turns new wine sour, crops touched by it become barren, grafts die, seeds in gardens are dried up, the fruit of trees falls off, the edge of steel and the gleam of ivory are dulled, hives of bees die, even bronze and iron are at once seized by rust, and a horrible smell fills the air; to taste it drives dogs mad and infects their bites with an incurable poison. If a woman strips herself naked while she is menstruating and walks around a field of wheat, the caterpillars, worms, beetles, and other vermin will fall off from the ears of corn. All plants will turn of a yellow complexion on the approach of a woman who has the menstrual discharge upon her. Bees will forsake their hives at her touch, for they have a special aversion to a thief and a menstruous woman, and a glance of her eyes suffices to kill a swarm of bees.

Throughout early history, the fear of blood spawned many ancient taboos. Almost universally, menstruating women were isolated and prevented from handling food. Most primitive peoples regarded women as unclean during menstruation and subjected them to segregation and special rituals. It is therefore not surprising that, even with growing sophistication, negative attitudes toward menstruation persisted into modern times.

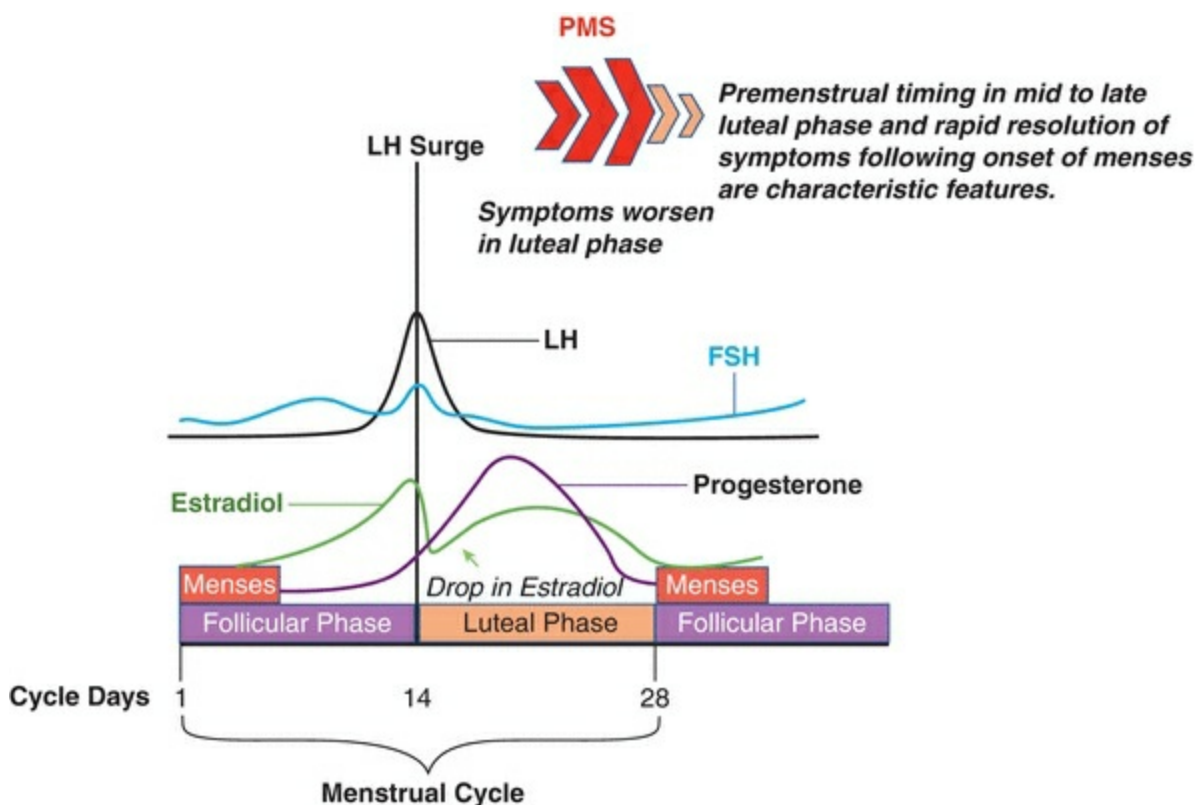
In 19th and early 20th century Europe, menstruation was commonly associated with antisocial behavior.<sup>3</sup> In 1845, a domestic servant who murdered one of her employer's children was acquitted on the grounds of insanity due to obstructed menstruation. In 1851, a woman was acquitted of murdering her baby niece due to insanity arising from disordered menstruation. As recently as 1984, Dalton argued that the premenstrual phase of the cycle was associated with an increased incidence of crime, jailing for alcoholism, poor academic performance, sickness in industry, and hospitalization for accidents.<sup>4</sup> However, careful studies have found no significant variations in cognitive or

motor functions across the menstrual cycle,<sup>5,6,7,8</sup> suggesting that, to a large extent, behaviors merely reflect societal expectations. Unfortunately, even today, expectations and attitudes toward menstruation are influenced heavily by old traditions and social and cultural beliefs.



# THE PREMENSTRUAL SYNDROME AND PREMENSTRUAL DYSPHORIC DISORDER

The simplest definition of the premenstrual syndrome (PMS) is a common sense one: cyclic physical and behavioral symptoms that appear in the days preceding menses, are bothersome enough to interfere with work or lifestyle, and are followed by a symptom-free interval (Figure 14.1). Premenstrual dysphoric disorder (PMDD) describes a severe form of PMS that some consider a distinct clinical entity, characterized by prominent symptoms of irritability, anger, internal tension, dysphoria, and mood lability.<sup>9</sup>



**FIGURE 14.1**

Historically, the phrase “premenstrual syndrome” was used first by Greene and Dalton in their report of 84 cases in 1953.<sup>10</sup> However, R.T. Frank, then the chief of obstetrics and gynecology at Mt. Sinai Hospital in New York City, generally is credited with having first described PMS, in 1931<sup>11</sup>:

The group of women to whom I refer especially complains of a feeling of

indescribable tension from 10 to 7 days preceding menstruation, which in most instances continues until the time that the menstrual flow occurs. The patients complain of unrest, irritability, like jumping out of their skin, and a desire to find relief by foolish and ill-considered actions. Their personal suffering is intense and manifests itself in many reckless and sometimes reprehensible actions. Not only do they realize their own suffering, but they feel conscience-stricken toward their husbands and families, knowing well that they are unbearable in their attitude and reactions. Within an hour or two after the onset of the menstrual flow, complete relief from both physical and mental tension occurs.

An extraordinary array of different physical and behavioral symptoms has been attributed to PMS. The most common physical symptoms include abdominal bloating, extreme fatigue, breast tenderness, and headaches, all occurring in 50–90% of cases. The most prevalent behavioral symptoms of PMS are mood lability, irritability, depressed mood, increased appetite, forgetfulness, and difficulty with concentration, occurring in 50–80% of cases. Other less common symptoms include anxiety or tension, easy crying, thirst, acne, gastrointestinal upset, hot flushes, palpitations, dizziness, and lower extremity edema. Symptoms of PMS typically arise during the last 7–10 days of the menstrual cycle.<sup>12</sup>

Premenstrual symptoms are very common, reported by up to 75% of women with regular menstrual cycles. However, because women naturally relate symptoms and behaviors to menstruation retrospectively, estimates of their frequency are subjective and inherently biased.<sup>13</sup> Moreover, both men and women have been conditioned to expect symptoms during the premenstrual phase of the cycle, such as fluid retention, pain, and emotional lability, and not surprisingly, they report such symptoms when asked in retrospect.<sup>14</sup> The power of conditioned response was illustrated in a classic study by Ruble, in which 44 undergraduates at Princeton University were deliberately deceived about the phase of their menstrual cycle.<sup>15</sup> A mock electroencephalogram was performed, complete with electrodes attached to the head, after being described as a new technique that could predict the onset of menstruation. Subjects were informed that they were premenstrual (expected menses in 1–2 days) or intermenstrual (expected menses in 7–10 days), and only those led to believe they were premenstrual reported increased symptoms of pain, water retention, and changes in eating habits—a self-fulfilling prophecy. Subjects tend to comply with what they believe is the investigator's hypothesis, and in studies of PMS, no differences in symptoms can be demonstrated when the purpose of the study is disguised or expectations are manipulated.<sup>16,17,18</sup> Carefully designed prospective studies have revealed that some women who have no demonstrable cyclic premenstrual symptoms or changes in cognitive function

nonetheless believe that they do,<sup>13</sup> even including some diagnosed with PMDD.<sup>5,19,20</sup>  
**When strictly defined based on prospective symptom diaries, clinically significant PMS occurs in 20–30% and PMDD affects 2–8% of women.**<sup>9,21,22,23,24</sup>

# Diagnostic Criteria

The diagnosis of both PMS and PMDD depends on the presence of typical symptoms, their timing, severity, and the exclusion of other diagnoses. **Both diagnoses require a prospective symptom diary documenting specific cyclic symptoms associated with the luteal and menstrual phases of the cycle and are severe enough to adversely impact social functioning and quality of life of the affected women.**<sup>25</sup> The specific collection of symptoms in a given individual is much less important than the cyclic nature of the symptom complex and its temporal relationship with menses. When symptoms are charted accurately, as much as 40% of women presenting with presumed PMS do not exhibit the distinctly cyclic pattern required for diagnosis and actually have an underlying mood or anxiety disorder.<sup>26</sup>

The most commonly used criteria for diagnosis of PMS are those proposed by investigators at the University of California at San Diego (UCSD).<sup>12,27</sup> The diagnostic criteria were based on prospective symptom diaries of women in whom underlying medical conditions and psychiatric disorders were carefully excluded and on an analysis of cycle phase defined by daily urinary steroid metabolites.<sup>27</sup> A symptom survey instrument known as the Calendar of Premenstrual Experiences (COPE) was constructed, including the 10 most commonly reported physical symptoms and the 12 most commonly reported behavioral symptoms, with each ranked on a 4-point Likert scale of severity across the menstrual cycle (**Figure 14.2**).<sup>12,28</sup>

Calendar of Premenstrual Experiences<sup>12, 28</sup>

Name \_\_\_\_\_ Month/Year \_\_\_\_\_ Age \_\_\_\_\_

Begin your calendar on the first day of your menstrual cycle. Enter the date below the cycle day. Day 1 is your first day of bleeding. Shade the box above the cycle day if you have bleeding.  Enter an X for spotting .

If more than one symptom is listed in a category (i.e., nausea, diarrhea, constipation), you do not need to experience all of these. Rate the most disturbing of the symptoms on the 0–3 scale below.

Weight: Weigh yourself before breakfast. Record your weight in the box below date. Symptoms: Indicate the severity of your symptoms by using the 1–3 scale below. Rate each symptom at about the same time each evening.

- 0 = None (symptoms not present)                    2 = Moderate (interferes with normal activities)  
 1 = Mild (noticeable but not troublesome)        3 = Severe (intolerable, unable to perform normal activities)

Other Symptoms: If there are other symptoms you experience, list and indicate severity.  
 Medications: List any medications taken and enter an X on the corresponding day(s).

Bleeding	1	2	3	4	5	6	7	8	9	10	11	12	13	14	15	16	17	18	19	20	21	22	23	24	25	26	27	28	29	30
Cycle Day																														
Date																														
Weight																														
Symptoms																														
Acne																														
Bloating																														
Breast tenderness																														
Dizziness																														
Fatigue																														
Headache																														
Hot flashes																														
Nausea, diarrhea, constipation																														
Palpitations																														
Swelling (hands, ankles, feet)																														
Angry outbursts, arguments, violent tendencies																														
Anxiety, tension, nervousness																														
Confusion, poor concentration																														
Easy crying																														
Depression																														
Food cravings (salt, sweets)																														
Forgetfulness																														
Irritability																														
Increased appetite																														
Mood swings																														
Overly sensitive																														
Wish to be alone																														
Other symptoms																														
1.																														
2.																														
Medications																														
1.																														
2.																														

**FIGURE 14.2**

The COPE survey instrument yields reliably reproducible scores that correlate well with those derived from administering the Profile of Mood States<sup>29</sup> and the Beck Depression Inventory.<sup>30</sup> Although a number of other scales can be used for diagnosis of PMS (Table 14.1), the COPE survey remains among the most popular, primarily because analysis of data derived from its use has revealed that virtually all women with PMS can be identified using a simplified list of six behavioral symptoms and four physical symptoms, yielding a set of diagnostic criteria that can be applied easily in a patient interview, as follows<sup>12</sup>:

**TABLE 14.1 Survey Tools for Assessing Premenstrual Syndrome and Premenstrual Dysphoric Disorder**

Tool Acronym/Abbreviation	Tool (Full) Title	Reference and Resources
COPE	Calendar of Premenstrual Experiences	See Ref. <sup>12</sup>
MDQ	Moos Menstrual Distress Questionnaire	See Ref. <sup>31</sup>
PAF	Premenstrual Assessment Form	See Ref. <sup>32,33</sup>
PRISM	Prospective Record of Severity of Menstruation	See Ref. <sup>34</sup>
DRSP	Daily Record of Severity of Problems	See Ref. <sup>35</sup>
PSST	Premenstrual Symptoms Screening Tool	See Ref. <sup>36</sup>

1. Self-report of 1 or more affective symptoms **and** 1 or more somatic symptoms during the 5 days preceding menses in each of three menstrual cycles. See Table 14.2.
2. Relief from symptoms within 4 days after the onset of menses, without recurrence before cycle day 12 in a 28-day cycle.
3. Absence of any medications, hormone therapy, drug, or alcohol use.
4. Social dysfunction and personal distress, as indicated by one of the following:
  - Discord in the relationship with a partner, confirmed by the partner
  - Parenting difficulties
  - Poor work/school performance or attendance
  - Increased social isolation
  - Legal problems
  - Suicidal ideation
  - Seeking medical care for somatic symptoms

## **TABLE 14.2 Affective and Somatic Symptoms**

## Affective Symptoms

## Somatic Symptoms

Depression

Breast tenderness

Angry outbursts

Abdominal bloating

Irritability

Headache

Confusion

Swollen extremities

Social withdrawal

Fatigue

According to the guidelines from the National Institute of Mental Health (NIMH),<sup>37</sup> the diagnosis of PMS also should require at least a 30% increase in the severity of symptoms over the 5 days before menses, compared with the 5 days after onset of menses. **Based on the UCSD and NIMH criteria, it is estimated that approximately 5% of women of reproductive age can be diagnosed with disruptive PMS.**<sup>38,39,40</sup>

The most commonly used criteria for the diagnosis of PMDD are those proposed by the American Psychiatric Association, as they appear in the current Diagnostic and Statistical Manual of Mental Disorders (DSM-V)<sup>41</sup>:

- A. In the majority of menstrual cycles, at least five symptoms must be present in the final week before the onset of menses, start to improve within a few days after the onset of menses, and become minimal or absent in the week postmenses.
- B. One (or more) of the following symptoms must be present:
  1. Marked affective lability (e.g., mood swings; feeling suddenly sad or tearful, or increased sensitivity to rejection).
  2. Marked irritability or anger or increased interpersonal conflicts.
  3. Marked depressed mood, feelings of hopelessness, or self-deprecating thoughts.
  4. Marked anxiety, tension, and/or feelings of being keyed up or on edge.
- C. One (or more) of the following symptoms must additionally be present, to reach a total of five symptoms when combined with symptoms from Criterion B above.



1. Decreased interest in usual activities (e.g., work, school, friends, hobbies).
2. Subjective difficulty in concentration.
3. Lethargy, easy fatigability, or marked lack of energy.
4. Marked change in appetite; overeating; or specific food cravings.
5. Hypersomnia or insomnia.
6. A sense of being overwhelmed or out of control.
7. Physical symptoms such as breast tenderness or swelling, joint or muscle pain, a sensation of “bloating,” or weight gain.

**Note:** The symptoms in Criteria A–C must have been met for most menstrual cycles that occurred in the preceding year.

D. The symptoms are associated with clinically significant distress or interference with work, school, usual social activities, or relationships with others (e.g., avoidance of social activities; decreased productivity and efficiency at work, school, or home).

E. The disturbance is not merely an exacerbation of the symptoms of another disorder, such as major depressive disorder, panic disorder, persistent depressive disorder (dysthymia), or a personality disorder (although it may co-occur with any of these disorders).

F. Criterion A should be confirmed by prospective daily ratings during at least two symptomatic cycles. (**Note:** The diagnosis may be made provisionally prior to this confirmation.)

G. The symptoms are not attributable to the physiological effects of a substance (e.g., a drug of abuse, a medication, other treatment) or another medical condition (e.g., hyperthyroidism).

**It is important to note that whereas the diagnosis of PMS requires both affective and somatic symptoms, the diagnosis of PMDD can include, but does not require, somatic symptoms.** Another distinction between the two disorders is that PMDD may be superimposed on another psychiatric disorder, whereas the diagnosis of PMS can only be made in their absence.

**The diagnoses of PMS and PMDD must be differentiated from other underlying psychiatric disorders, which are common among women with similar symptoms.**<sup>26,42,43</sup> Medical conditions, such as hyperthyroidism and hypothyroidism, also should be excluded. A study involving a group of women evaluated in a specialty PMS clinic found that 13% had a distinct affective psychiatric disorder, 38% had premenstrual exacerbation of an underlying depressive or anxiety disorder, and only 44% of PMS-like presentations actually met strict diagnostic criteria for PMS.<sup>44</sup> Women with PMS often have a history of a previous major depressive episode and also are at increased risk for major depression in the future.<sup>45,46</sup> **Women who have no**

**demonstrable symptom-free interval during the follicular phase of the cycle merit careful evaluation for a mood or anxiety disorder.**

Migraine headache and symptoms of chronic fatigue syndrome and irritable bowel syndrome frequently are more pronounced during the premenstrual phase of the cycle. However, in women with these syndromes, symptoms also occur at other times in the cycle.<sup>47</sup>

# Pathophysiology

Scientific evidence for the mechanism(s) involved in PMS and PMDD has been difficult to produce, but there has been no shortage of theories; the list is impressive:

- Low progesterone levels
- High estrogen levels
- Falling estrogen levels
- Changes in the estrogen/progesterone ratio
- Increased aldosterone activity
- Increased rennin-angiotensin activity
- Increased adrenal activity
- Endogenous opiate withdrawal
- Subclinical hypoglycemia
- Central changes in catecholamines
- Responsiveness to prostaglandins
- Vitamin and mineral deficiencies
- Excess prolactin secretion

In his original description of PMS, R.T. Frank summarized 15 cases, theorized that the problem resulted from an excess of female sex hormones due to inadequate excretion, and reported that he could provide relief by withdrawing blood from his patients. Accordingly, he applied treatments designed to increase excretion, such as calcium lactate, caffeine, and laxatives. For severe cases, he prescribed pelvic irradiation to cause ovarian failure. In 1934, S. Leon Israel proposed the opposite theory—that PMS was caused by defective luteinization, progesterone deficiency, and relative hyperestrogenism.<sup>48</sup>

The role of ovarian steroid hormones in PMS is suggested strongly by the lasting response to oophorectomy in women unresponsive to medical therapy<sup>49,50</sup> and by the dramatic decrease in symptoms after suppression of the hypothalamic-pituitary-ovarian axis by treatment with a long-acting gonadotropin-releasing hormone (GnRH) agonist.<sup>51,52,53,54</sup> However, studies comparing serum estrogen and progesterone levels have failed to identify any consistent differences between women with and without PMS/PMDD.<sup>55,56,57</sup> Moreover, an early onset of menses induced by treatment with a progesterone antagonist during the luteal phase does not decrease or otherwise change the symptoms of PMS, even when progesterone levels are maintained by simultaneous treatment with hCG.<sup>58,59</sup> In women with PMS treated with a GnRH agonist, symptoms recur when exogenous estrogen or progesterone is added to the treatment regimen, but not in those receiving add-back placebo treatment and not in normal women receiving

the same treatment.<sup>60</sup> Studies involving well-defined patient populations also have failed to demonstrate any differences in the levels of testosterone, follicle-stimulating hormone (FSH), luteinizing hormone (LH), prolactin, sex hormone-binding globulin, and aldosterone between women with and without symptoms of PMS, in any phase of the menstrual cycle.<sup>61</sup> **Taken together, these observations suggest that the symptoms of PMS are not caused directly by endocrine events during the luteal phase but reflect an abnormal response to normal cyclic changes in ovarian steroid hormone levels.**

The menstrual cycle is associated with significant changes in the opioid,<sup>62</sup> gamma-aminobutyric acid (GABA),<sup>63</sup> and serotonin neurotransmitter systems,<sup>64</sup> suggesting a possible pathophysiologic mechanism for PMS. Lower midcycle and luteal phase serum  $\beta$ -endorphin levels have been observed in women with PMS, compared to normal women.<sup>65,66,67</sup> The anxiolytic actions of certain progesterone metabolites that act as ligands for the GABA-A receptor<sup>63</sup> and the effectiveness of alprazolam (a short-acting benzodiazepine) in relieving symptoms of PMS<sup>68</sup> suggest the disorder might involve a disturbance in the GABAergic system. However, studies comparing the levels of anxiolytic progesterone metabolites in women with and without PMS have observed no consistent differences.<sup>57,69</sup> Several lines of evidence suggest that the mood symptoms of PMS may relate to serotonin depletion. Whole blood serotonin concentrations and platelet serotonin uptake and imipramine binding (a marker of CNS binding and serotonergic activity) during the luteal phase are lower in women with PMS than in asymptomatic women.<sup>70,71,72,73,74</sup> Symptoms of PMS are aggravated by acute dietary tryptophan depletion, which suppresses brain serotonin synthesis,<sup>75</sup> and relieved by treatment with fenfluramine, a serotonin agonist,<sup>76</sup> or fluoxetine, a selective serotonin reuptake inhibitor (SSRI). Moreover, mood symptoms in women with PMDD receiving treatment with fluoxetine promptly return after treatment with metergoline, a serotonin antagonist.<sup>77</sup> **The weight of current evidence thus suggests strongly that PMS and PMDD result from an abnormal or exaggerated effect of cyclic changes in ovarian steroid hormones on central neurotransmitter mechanisms and that serotonin, in particular, plays an important role in their pathophysiology.**

In general, thyroid function is normal in women with PMS.<sup>78</sup> Approximately 10% of women with PMS have demonstrably abnormal thyroid function, but the prevalence is not significantly different from that of subclinical hypothyroidism in the general population. Overall, the thyroid-stimulating hormone (TSH) response to thyroid-releasing hormone (TRH) is normal. Although abnormal responses (both exaggerated and blunted) are observed more often in women with PMS,<sup>79</sup> they occur just as often during the follicular phase as in the luteal phase. Moreover, the effect of treatment with

thyroxine is no different from that of placebo, even in patients with an abnormal response to TRH.

Studies of twins have found evidence to suggest that genetic factors might predispose to PMS and PMDD.<sup>80,81</sup> The correlation between menstrual symptoms in mothers and daughters and between sisters suggests a genetic influence but also might merely reflect a learned or conditioned response, at least to some extent.<sup>82,83</sup> Whereas many have speculated that differences in personality, stress levels, or coping mechanisms may play a role in PMS, there is little or no evidence to support the hypothesis.<sup>84,85,86</sup>

Some evidence suggests that women with PMS ingest more alcohol than others and that women with a family history of alcoholism exhibit more premenstrual anxiety and other behavioral symptoms, but a link between alcoholism and PMS has not been established.<sup>87,88</sup> Efforts have examined roles for vitamin and mineral deficiencies in women with PMS. Studies comparing serum levels of vitamin A and vitamin E in women with and without PMS have observed no significant differences.<sup>89,90</sup> The results of treatment with vitamin B<sub>6</sub> generally are unimpressive and inconsistent.<sup>91,92</sup> A number of studies have found that intracellular and circulating magnesium concentrations are lower in women with PMS than in asymptomatic control women, but the significance of these observation remains unclear.<sup>93,94,95,96,97</sup> Vitamin D insufficiency has been linked with PMS, and dietary intake of calcium and vitamin D has been shown to relate to risk for PMS.<sup>98,99</sup>

# Treatment

The key to effective treatment of PMS and PMDD is accurate diagnosis, which rests primarily on the collection of objective evidence that the patient's symptoms are clearly cyclic, as documented by use of the COPE survey or other similar calendar-based screening tool over the interval spanning three menstrual cycles.

A number of medications have proven beneficial to women with PMS or PMDD, including SSRIs,<sup>100,101</sup> alprazolam (a benzodiazepine),<sup>68,102,103</sup> and GnRH agonists (Table 14.3).<sup>53,104</sup> Accumulated evidence indicates that certain oral contraceptives,<sup>105,106,107</sup> exercise,<sup>108,109</sup> relaxation techniques,<sup>110,111</sup> spironolactone,<sup>112,113,114,115</sup> and danazol<sup>114</sup> also have some value. Older treatment regimens involving progesterone or progestins,<sup>117,118,119,120,121</sup> tricyclic antidepressants, monoamine oxidase inhibitors, lithium, evening primrose oil,<sup>122</sup> essential free fatty acids,<sup>123</sup> dietary restrictions, vitamin supplements, and ginkgo biloba generally are not effective. Improvements in symptoms have been described with vitamin D and calcium supplementation.<sup>99,124,125,126,129</sup>

## TABLE 14.3 Treatments for Premenstrual Syndrome and Premenstrual Dysphoric Disorder

Demonstrated as Effective	Possibly Effective	Ineffective
Selective serotonin reuptake inhibitors	Oral contraceptives	Progesterone
Alprazolam	Spironolactone	Vitamins B, E
GnRH agonists	Exercise	Dietary restrictions
Drospirenone containing OCP's	CBT	
Danazol	Magnesium	

## The Placebo Response

The strange-sounding word placebo is derived from the Latin verb meaning “I shall please.” Clinicians and patients have been conditioned to observe a prescription ritual. Many patients seem to feel that their complaints are not taken seriously unless a medication is prescribed. However, placebo is more than a pill; it is a process.<sup>128</sup>

The process begins with confidence in the clinician and extends to the patient’s own healing system. Interaction with a clinician provides a better understanding of a patient’s symptoms, eliminates some unfounded fears, and offers hope for improvement. Many of the treatments for PMS that provide women with a greater sense of control, even simple measures such as changes in diet and lifestyle, can yield benefits. The very process of making detailed, prospective observations of events in life can improve one’s sense of self-control, which is intrinsically therapeutic.

Leon Eisenberg penned some very insightful thoughts regarding the placebo response, which plays a prominent role in the therapeutics of PMS and PMDD<sup>129</sup>:

So emphatically does the phrase “placebo response” discredit the psychosocial aspects of the therapeutic encounter that it may be time to eradicate it from our language. Let us replace it by some such term as “the response to care,” “the response to the doctor,” or “the healing response” in order to emphasize that it is (a) powerful, (b) no less “real” than drug actions, and (c) embedded in every therapeutic transaction. Its mechanisms are some compound of the arousal of hope, the comfort of reassurance, taking an active rather than a passive role in managing the illness experience, and reinterpreting the meaning of the illness. It is perverse that “placebo” has almost become an epithet implying charlatanism rather than a descriptor of a fundamental characteristic of medical practice. We ought equally to seek an understanding of the healing response rather than disdaining it, as the “hard” scientist does, or being deceived by it, as practitioners often are.<sup>130</sup>

## **Selective Serotonin Reuptake Inhibitors (SSRIs) and Selective Serotonin and Norepinephrine Reuptake Inhibitors (SNRIs)**

There is substantial evidence for the effectiveness of SSRIs in the treatment of PMS and PMDD.<sup>100,101,131</sup> Fluoxetine (Prozac), in a daily dose of 20 mg, has demonstrated sustained efficacy for relieving both somatic and mood symptoms and generally is well tolerated.<sup>132,133,134,135</sup> Other SSRIs also are effective, including sertraline (Zoloft, 50–150 mg daily),<sup>136,137</sup> paroxetine (Paxil, 20–30 mg daily),<sup>138</sup> and citalopram (Celexa, 20–30 mg daily).<sup>139</sup> Venlafaxine (Effexor, 50–200 mg daily), an SNRI, also has efficacy,<sup>140</sup> as do other antidepressants that inhibit serotonin reuptake or antagonize its action, such as clomipramine<sup>141,142</sup> and nefazodone.<sup>143</sup>

Although SSRIs and related drugs are administered most commonly on a continuous daily basis, an intermittent treatment regimen limited to the luteal phase, or one beginning at the onset of symptoms, can be equally or more effective while offering the potential advantages of lower cost and fewer side effects.<sup>139,142,144,145</sup> In some clinical trials, treatment for as few as 3 days was effective.<sup>146,147</sup> However, some women require higher doses or continuous treatment to achieve benefit.<sup>148,149,150</sup> **If SSRIs and SNRIs are initiated as a continuous regimen, it is important for prescribers to ensure that these agents should be discontinued gradually to minimize withdrawal symptoms; luteal regimens do not require taper.**

## **Alprazolam**



Alprazolam, a benzodiazepine, is another medication that may be useful in the treatment of PMS and PMDD,<sup>68,102,103</sup> although its effectiveness may be limited to the relief of depressive symptoms. Because the drug also has addictive potential, it generally is considered a second-line agent and is best used only intermittently.

## **Gonadotropin-Releasing Hormone Agonists**

The clinical utility of GnRH agonists in the treatment of PMS/PMDD was first demonstrated in 1984.<sup>151</sup> Although now an established treatment,<sup>53,104</sup> GnRH agonists generally are more effective for relieving irritability and physical symptoms than for the treatment of prominent symptoms of depression or dysphoria.<sup>53,152</sup> GnRH agonist treatment is associated with the well-known symptoms of hypoestrogenism (e.g., hot flashes), which can be severe, and prolonged use invites longer-term consequences (bone mineral depletion).<sup>52</sup> However, these limitations can be negated largely by simultaneous “add-back” treatment with low doses of estrogen or estrogen and progestin, which does not reduce the overall efficacy of GnRH agonist therapy.<sup>51,153,154,155</sup>

## **Combined Hormonal Contraceptives**

Combined oral contraceptives (COC's) are one of the oldest and simplest methods for treatment of PMS/PMDD, based on the idea of substituting a constant hormonal environment for the dynamic cyclic pattern of the normal menstrual cycle. Early clinical studies found that oral contraceptives helped to relieve breast pain and symptoms of bloating but had no detectable benefits for relieving mood symptoms.<sup>156</sup> More recent studies involving the use of an oral contraceptive containing the progestin drospirenone have observed that treatment can achieve modest improvement in a wide range of symptoms, including behavioral and mood symptoms, particularly when the usual 7-day pill-free interval is shortened to 4 days.<sup>105,106,157,158</sup> Extended regimens can be superior to cyclic by providing a relative hormonal steady state. Similar to oral contraceptives, improvement in PMS is described with use of vaginal combined hormonal contraceptive ring.<sup>159</sup>

## **Complementary Therapies**

### **Exercise and Relaxation Techniques**

There is some evidence to indicate that aerobic exercise,<sup>108,109</sup> relaxation,<sup>110</sup> and reflexology<sup>111</sup> can help to relieve the symptoms of PMS. These approaches are of particular relevance for women who may not tolerate the hormonal or neuromodulator

options discussed earlier. Existing data suggest that their efficacy is not compelling and may reflect only a placebo response.

## Alternative Therapies

Alternative therapies are limited, although inconsistent benefits have been implied in trials of chasteberry and St. John's Wort.<sup>130,160,161</sup>

## Spironolactone

Spironolactone is a potassium-sparing diuretic having structural similarity to steroid hormones and has been used widely in the treatment of PMS. In clinical trials, spironolactone has proven more effective than placebo in relieving symptoms of irritability, depression, bloating, breast tenderness, and food craving.<sup>113,114,115</sup> In one placebo-controlled randomized trial, a significant difference in serum androgen levels from the follicular to the luteal phase of the cycle was observed in those who subsequently responded to treatment with spironolactone.<sup>112</sup>

## Progesterone

In the past, progesterone treatment by injection or suppository was used commonly in the management of PMS, having been actively promoted by Dalton.<sup>4</sup> Early studies that failed to detect a benefit were criticized for the size of the study population and doses of progesterone that were employed.<sup>162,163,164,165</sup> In a study that attempted to negate the placebo response by eliminating any contact with the investigators or any health care providers during the trial, both progesterone and placebo failed to achieve any measurable benefits.<sup>166</sup> Controversies regarding the value of progesterone treatment were largely put to rest by the results of large double-blind, placebo-controlled trials finding that the effects of progesterone (400, 800, 1,200 mg daily) were not different from those of placebo.<sup>117,167</sup> A meta-analysis including 10 trials of progesterone therapy involving 531 women and 4 trials of progestin therapy involving 378 women found that neither is effective for management of the symptoms of PMS.<sup>118</sup> A recent Cochrane systematic review concluded the available data do not indicate that progesterone is an effective treatment for PMS.<sup>168</sup>

## Danazol<sup>169</sup>

A synthetic derivative of 17 $\alpha$ -ethinyltestosterone with diverse modes of actions that include suppression of pituitary gonadotropins, receptor-mediated androgenic and progestational effects, as well as immunomodulation. Danazol has demonstrated

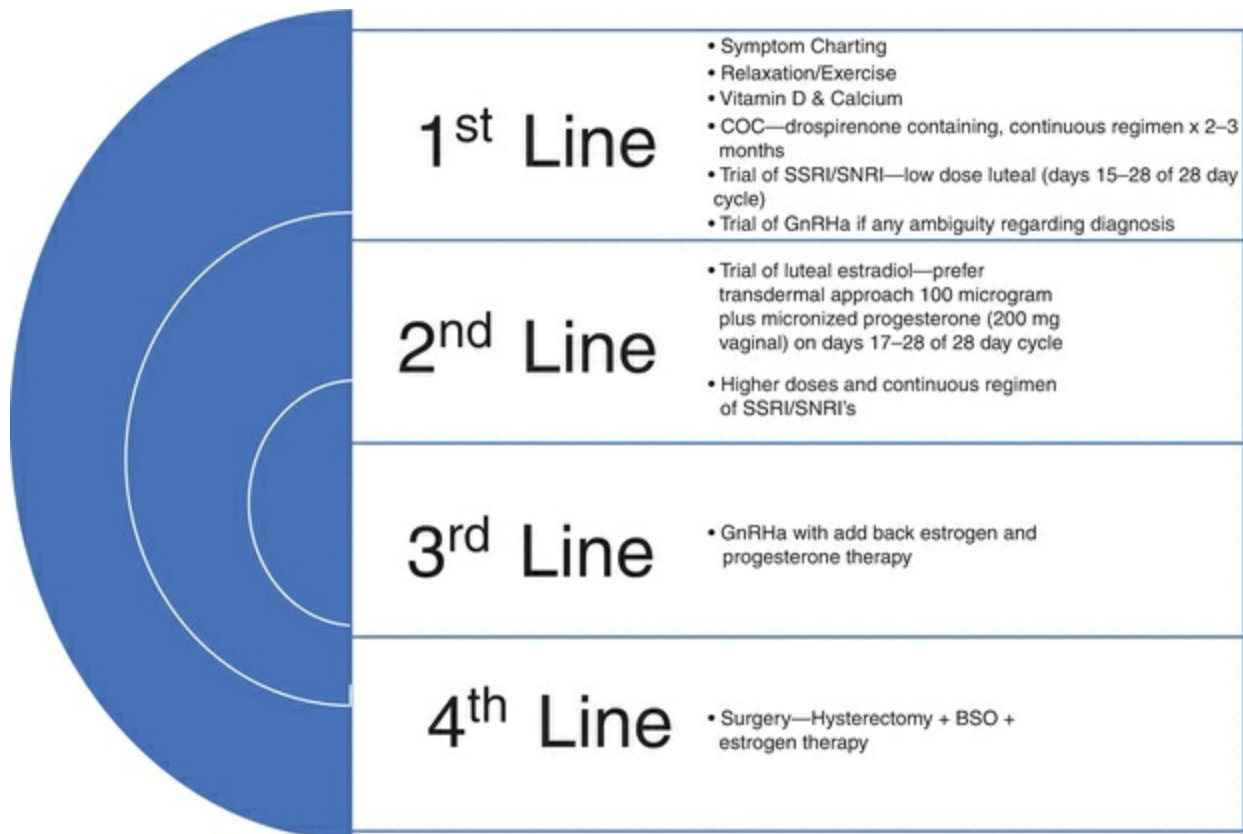
efficacy in the management of endometriosis as well as reduced severity of PMS symptoms when used in 200 mg twice daily regimen.<sup>116</sup>

## Role of Surgery

Hysterectomy and bilateral salpingo-oophorectomy have on rare occasions shown to offer benefit in severe cases of PMS/PMDD,<sup>170,171</sup> when medical therapy has failed, when patient is unwilling to commit to long-term use of GnRHa, or when additional gynecologic comorbidities such as symptomatic fibroids exist. Proven efficacy of benefit from ovarian suppression with GnRHa and tolerance of add-back estrogen therapy should precede a decision to proceed with surgery. Hormone therapy is advised following surgical menopause to minimize symptom burden of resulting hypoestrogenemia and the long-term sequelae therefrom (discussed in detail in [Chapter 17](#)). While removal of the ovaries alone will confer benefit, retention of the uterus necessitates a need for adding progesterone (which is associated with PMS-like symptoms) to hormone therapy regimen. Surgical absence of the uterus simplifies hormone therapy as there is no more need for adding progesterone to the hormone replacement regimen.

## Choice of Treatment

When symptoms are mild and evidence of significant psychosocial dysfunction is lacking, a trial of relaxation strategies and aerobic exercise can be tried as first-line approach. If symptoms of bloating and fluid retention are prominent, a trial of spironolactone can be justified. Women in need of contraception are logical candidates for treatment with oral contraceptives, with a shorter than usual pill-free interval, or in a daily continuous regimen. **In our opinion, drospirenone containing combined hormonal contraceptives, dispensed as a continuous regimen, should be considered as a first-line pharmaceutical approach to bothersome PMS ([Figure 14.3](#)).**



COC: Combined oral contraceptive  
 SSRI: Selective serotonin reuptake inhibitor  
 SNRI: Selective norepineprine reuptake inhibitor  
 GnRHa: GnRH agonist  
 BSO: Bilateral salpingo-oophorectomy

**FIGURE 14.3**

**Women who meet strict criteria for diagnosis of PMS or PMDD, including psychosocial dysfunction, are candidates for treatment with an SSRI (fluoxetine, sertraline, paroxetine) or an SNRI (venlafaxine); based on the severity of both, these agents can be administered daily or only during the luteal phase. Common side effects of SSRIs include nausea, jitteriness, and headache. When side effects prove limiting, a trial with a lower dose or alternative drug is warranted. Sexual dysfunction, including anorgasmia and diminished sexual interest, is perhaps the most significant potential adverse effect of SSRI treatment, and women should be advised of this specific possibility before treatment begins.** Unfortunately, lower doses often do not eliminate this side effect. Approximately 30–40% of women may not respond to treatment with an SSRI over several cycles; a switch to another drug in the class is reasonable and often effective. Those who fail to respond to intermittent luteal phase treatment or to daily therapy may do better with the alternative treatment regimen. When SSRI treatment proves unsuccessful, low-dose alprazolam is a logical choice to try, although sedating side effects may limit its usefulness.

**In women diagnosed with PMS or PMDD who fail to respond to the treatments usually effective, it is important to consider underlying conditions such as major depression, a generalized anxiety disorder, or substance abuse.** In those with severe PMDD unassociated with such disorders, treatment with a GnRH agonist can be considered, preferably administered with low doses of add-back estrogen or estrogen/progestin. In those who respond well to this last-resort therapy, GnRH agonist treatment with add-back can be extended beyond the usual 6 months without risk for loss of bone density.

# DYSMENORRHEA

Dysmenorrhea is pain with menstruation, usually cramping in nature and centered in the lower abdomen (Figure 14.4). Dysmenorrhea generally is classified as primary or secondary.<sup>172</sup> **Primary dysmenorrhea is associated with ovulatory cycles and results from myometrial contractions, in the absence of demonstrable disease. Secondary dysmenorrhea refers to pain during menstruation that is associated with pelvic pathology, such as endometriosis, adenomyosis, or uterine myomas (Figure 14.5).**



FIGURE 14.4

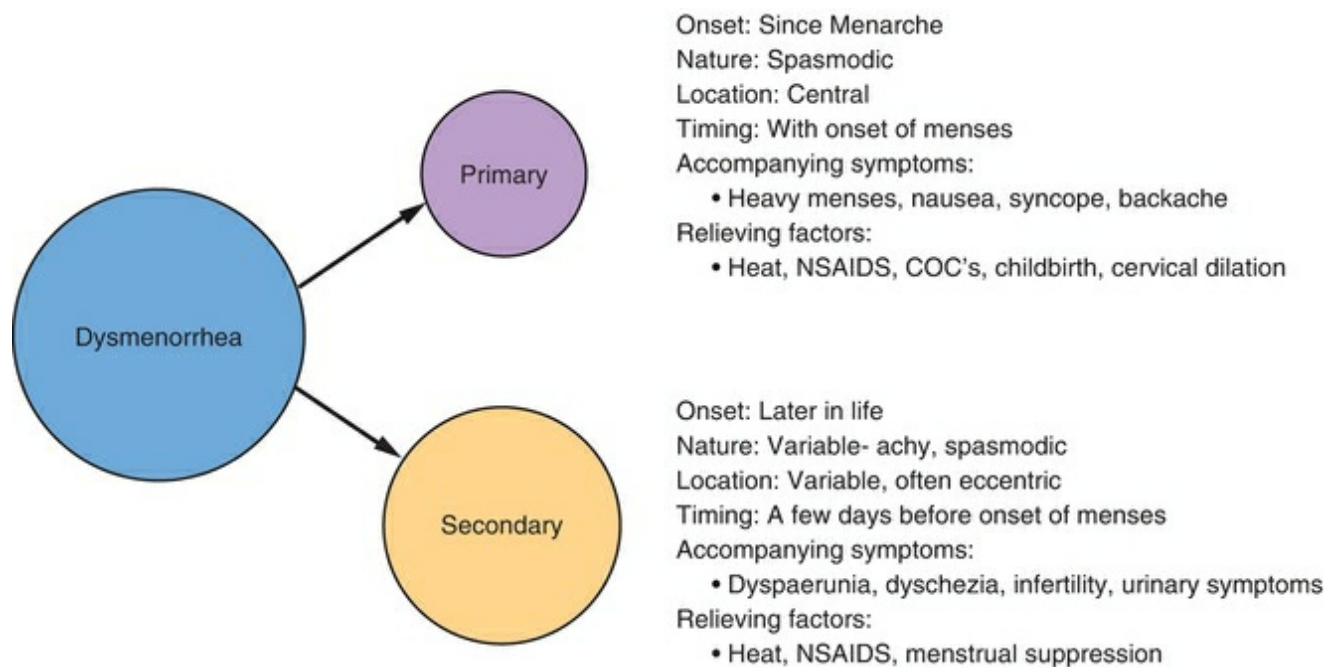


FIGURE 14.5

# Epidemiology

Dysmenorrhea is one of the most common gynecologic problems in reproductive age women. Primary dysmenorrhea usually begins during adolescence, but only after ovulatory cycles are established; 20–45% of teenage girls are ovulatory by 2 years after menarche, and 80% by 4–5 years.<sup>173</sup>

The overall prevalence of primary dysmenorrhea among adolescent girls is between 60% and 90% and decreases as age increases.<sup>174,175,176,177</sup> However, only approximately 15% of adolescent girls seek medical attention for complaints of menstrual pain.<sup>177</sup> In a random sample of 19-year-old women in Göteborg, Sweden, 72% reported dysmenorrhea, 38% regularly used medication, 15% had to limit their daily activity despite use of medication, and 8% missed school or work during every menses.<sup>178</sup> The severity of dysmenorrhea related directly to the volume and duration of menstrual flow. A later survey of the same cohort of women found that the prevalence of dysmenorrhea was decreased to 67% by age 24, with 10% still reporting limitation of daily activities.<sup>179</sup> The severity of dysmenorrhea also was reduced in women who had delivered a child in the intervening years, but not in those who had a miscarriage or abortion, and also was decreased in oral contraceptive users. A Canadian survey in a random sample of over 1,500 menstruating women observed that the prevalence of moderate or severe dysmenorrhea was 60%, resulting in decreased activity in 50% and missed school or work in 17%.<sup>180</sup> In the United States, approximately 60% of menstruating adolescents report dysmenorrhea, causing 14% to miss school regularly.<sup>177</sup> In a longitudinal American study of college women ages 17–19 years, 13% reported severe pain in more than half of their menstrual periods and 42% indicated that dysmenorrhea interfered with daily activities at least once.<sup>181</sup>

Risk factors for dysmenorrhea include a body mass index less than 20, early menarche (before age 12), longer intermenstrual intervals and duration of bleeding, irregular or heavy flow, premenstrual molimina, previous sterilization or history of sexual assault, and smoking.<sup>182</sup> Oral contraceptives, exercise, being married or in a stable relationship, and higher parity decrease the likelihood of dysmenorrhea.<sup>182</sup>

# Pathophysiology

**Accumulated evidence indicates that primary dysmenorrhea is caused by myometrial ischemia due to frequent and prolonged uterine contractions.** Studies of uterine blood flow using Doppler ultrasonography have revealed that uterine and arcuate artery resistance on the first day of menses is significantly higher in women with primary dysmenorrhea than in women without dysmenorrhea, suggesting that constriction of uterine vessels is the proximate cause for pain.<sup>183</sup>

The secretory endometrium contains substantial stores of arachidonic acid, which is converted to prostaglandin  $F_{2\alpha}$  ( $PGF_{2\alpha}$ ), prostaglandin  $E_2$  ( $PGE_2$ ), and leukotrienes during menses.  $PGF_{2\alpha}$  always stimulates uterine contractions and is the primary mediator of dysmenorrhea.<sup>184</sup> Endometrial concentrations of  $PGF_{2\alpha}$  and  $PGE_2$  correlate with the severity of dysmenorrhea.<sup>185</sup> Treatment with cyclooxygenase (COX) inhibitors decreases prostaglandin levels in menstrual fluid and uterine contractile activity; response curves correlate closely with serum drug levels.<sup>186,187</sup>

Uterine smooth muscle contractions cause the crampy, spasmodic lower abdominal and low back pain typical of dysmenorrhea and of prostaglandin-induced labor or abortion. In women with primary dysmenorrhea, uterine contractions during menses begin from an elevated level of basal tone ( $>10$  mm Hg), generate higher intrauterine pressures that frequently reach 150–180 mm Hg and can exceed 400 mm Hg, occur more frequently ( $>4$ – $5/10$  minutes), and are not rhythmic or coordinated.<sup>187</sup> When intrauterine pressure exceeds arterial pressure for a sustained period of time, ischemia results in the production of anaerobic metabolites that stimulate small type C pain neurons, which contributes to the pain of dysmenorrhea. Moreover,  $PGF_{2\alpha}$  and  $PGE_2$  can stimulate bronchial, bowel, and vascular smooth muscle contractions, causing bronchoconstriction, nausea, vomiting, diarrhea, and hypertension.

Classically, primary dysmenorrhea begins just before or coincident with the onset of menses and declines gradually over the subsequent 72 hours. The menstrual cramps are intermittent, vary in intensity, and usually are centered in the suprapubic region, although some women also experience pain in their thighs and lower back. Typically, the pattern is consistent across cycles. In contrast, women with secondary dysmenorrhea related to pelvic pathology, such as endometriosis, frequently report increasingly severe pain that often occurs at midcycle and during the week preceding menses, in addition to symptoms of deep dyspareunia and dyschezia (painful bowel movements). In those with secondary dysmenorrhea related to uterine myomas, pain results primarily from menorrhagia, with an intensity that correlates with the volume of menstrual flow.



# Diagnosis

**Primary dysmenorrhea is a clinical diagnosis, based primarily on a history of characteristic symptoms and a physical examination yielding no evidence or suspicion of specific pelvic pathology such as endometriosis, adenomyosis, uterine myomas, or chronic pelvic inflammatory disease.** In general, laboratory tests, imaging, and laparoscopy are not necessary for diagnosis.

A careful menstrual history should include the age at menarche and at onset of dysmenorrhea, intermenstrual interval, and volume and duration of flow: note any symptoms of intermenstrual or premenstrual spotting or staining. The relationship between the onset of pain and the onset of flow, the severity and location of pain, and the presence of any associated nausea, vomiting, diarrhea, back pain, or headache should be determined. The extent to which the pain interferes with daily activities (work, school, or exercise), the use of medications and their effectiveness, any progression in severity over time, and the presence of pain at times other than during menses also should be defined. These historical features generally can distinguish reliably women with primary dysmenorrhea from those with secondary dysmenorrhea.

Whereas women with primary dysmenorrhea typically report the onset of menstrual pain before the age of 25, those with adenomyosis tend to present later, generally after age 35, and often also report noncyclic chronic pelvic pain. Women with endometriosis typically have pain at times other than during menses and frequently also report premenstrual spotting, dyspareunia, dyschezia, limited relief from treatment with non-steroidal anti-inflammatory drugs (NSAIDs), and increasing severity over time. Because NSAIDs generally are highly effective in relieving the pain of primary dysmenorrhea, pain that proves refractory to such treatment suggests pelvic pathology.

Women with primary dysmenorrhea usually have a normal pelvic examination. In those with secondary dysmenorrhea related to pelvic pathology, the pelvic examination can be normal but often is not, providing clues to the underlying cause. Adenomyosis often is associated with a bulky, globular, and tender uterus, whereas those with myomas frequently have an enlarged uterus with irregular contours. Women with secondary dysmenorrhea related to endometriosis often have abnormal physical examination findings, which can include thickening, nodularity, or focally tender uterosacral ligaments, lateral cervical displacement due to shortening of one uterosacral ligament, cervical stenosis, or an enlarged ovary due to an endometrioma.<sup>188,189</sup> Interestingly, red hair, scoliosis, and dysplastic nevi also are observed more frequently in women with endometriosis.<sup>190,191,192</sup>

The diagnosis of primary dysmenorrhea does not require laboratory tests or imaging. However, transvaginal ultrasonography can be very helpful in identifying

uterine myomas, endometriomas, and adenomyosis in women with secondary dysmenorrhea.<sup>193</sup> Although numerous studies have demonstrated that serum CA 125 often is elevated in women with endometriosis, the test has limited clinical utility due to its low negative predictive value.<sup>194,195</sup>

# Treatment

A wide variety of therapies has been proposed for the treatment of dysmenorrhea. These include the application of heat, dietary and vitamin or herbal therapies, exercise, and behavioral interventions, as well as more traditional medications such as NSAIDs and oral contraceptives.

Data from two clinical trials suggest that application of a heated abdominal patch or wrap for 8–12 hours daily is more effective than placebo and can be as effective as treatment with an NSAID.<sup>196,197</sup> Results from a few small clinical studies have suggested that a vegetarian diet,<sup>198</sup> vitamin E,<sup>199,200</sup> combinations of vitamins (B<sub>1</sub>, B<sub>6</sub>, E), and Asian herbal remedies are more effective than placebo, but two systematic reviews have concluded that evidence is insufficient to justify recommending dietary and herbal therapies for the treatment of dysmenorrhea.<sup>201,202</sup> Studies of the effects of exercise on dysmenorrhea have yielded mixed results, with some reporting improvement and others finding that regular exercise worsened symptoms.<sup>203,204</sup> Although behavioral interventions aimed at changing the way women think about or respond to pain appear to help some women with dysmenorrhea, evidence for their effectiveness derives from small studies in heterogeneous populations and is not compelling.<sup>205</sup>

**For both adolescent girls and women with primary dysmenorrhea, NSAIDs are the first treatment of choice.**<sup>206,207,208</sup> There are numerous NSAIDs to choose from, including the propionic acid derivatives (e.g., naproxen, ibuprofen, and ketoprofen) and fenamates (e.g., mefenamic acid, tolfenamic acid, flufenamic acid, and meclofenamate); all are very effective (Table 14.4). Numerous clinical trials have demonstrated that NSAIDs provide effective relief in 70–90% of patients.<sup>209,210,211,212,213,214</sup> Their efficacy derives from both a decrease in endometrial prostaglandin production and from decreased menstrual flow. The fenamates also block prostaglandin actions.<sup>215</sup> Although some selective COX-2 inhibitors have been approved for treatment of primary dysmenorrhea, their higher cost and greater potential risks suggest their use should be limited to women at high risk for serious gastrointestinal side effects.

## TABLE 14.4 Common NSAID Treatment Regimens for Dysmenorrhea

<b>Drug</b>	<b>Initial Dose (mg)</b>	<b>Maintenance Dose (mg)</b>
<i>Propionic acid derivatives</i>		
Ibuprofen	400	400 q6h
Naproxen	500	250 q6–8h
Naproxen sodium	550	275 q6–8h
Ketoprofen	75	75 q8h
<i>Fenamates</i>		
Mefenamic acid	500	250 q4h
Meclofenamate	100	50–100 q6h

NSAID treatment can be started at the onset of menses and continued for the usual duration of pain. Women with severe dysmenorrhea might benefit from starting treatment 1–2 days before menstrual bleeding begins. NSAIDs should be taken with food to minimize common gastrointestinal side effects. The propionic acid derivatives are a good initial choice because they are inexpensive and available over the counter without a prescription. Patients do exhibit variations in response to different NSAIDs. Consequently, if one fails, substituting another in a different drug class is reasonable and appropriate (e.g., changing from ibuprofen to mefenamic acid). Because prostaglandins play a role in ovulation, treatment with NSAIDs has the potential to delay or prevent ovulation.<sup>214,215,216</sup> However, given that NSAID treatment for dysmenorrhea is remote from ovulation, women attempting to conceive generally can be reassured that treatment will not adversely affect their fertility.<sup>219</sup>

**Combined hormonal contraceptives also are effective treatment for dysmenorrhea. They can be considered a first-line agent in sexually active women**

**who require contraception and are a logical alternative for those who do not tolerate or gain sufficient relief from NSAID treatment.**<sup>220</sup> The efficacy of hormonal contraceptives derives from their inhibition of ovulation, thereby decreasing endometrial prostaglandin production, and from the decrease in the volume and duration of flow that results from endometrial attenuation after months of use.<sup>220,221,222,223</sup> Oral combined hormonal contraceptives can be used in the standard cyclic fashion (21–24 active pills followed by 4–7 inactive pills for oral) or in an “extended” cyclic manner that aims at reducing the frequency of withdrawal bleeding to every 3 months by either utilizing one of the newer oral formulations that contain 12 weeks of active pills, followed by 7 pills that are inactive or contain a low dose of estrogen only.<sup>224,225</sup> Alternatively, extended regimens can be achieved using the traditional 28-day pill packets by discarding placebo pills and starting a new set of 21 active pills until the 3rd pill packet, when placebo or hormone-free period will result in withdrawal bleeding. All regimens are effective. Extended cycles offer the added advantage of fewer menses, but also are associated with a higher prevalence of unscheduled spotting or bleeding.<sup>226</sup>

The contraceptive ring is as effective as oral contraceptives for the treatment of dysmenorrhea.<sup>227</sup> Similar to the pills, an extended regimen can be achieved when using a vaginal ring by postponing the hormone-free week to every 3rd month of use. Although no studies have focused on the use of depot medroxyprogesterone acetate for dysmenorrhea, a small study in adolescents found that two-thirds of subjects reported decreased dysmenorrhea during treatment.<sup>228</sup> Efficacy of contraceptive patch against dysmenorrhea remains less clear.

The levonorgestrel intrauterine system (device) has emerged as an effective and well tolerated approach for the management of both primary dysmenorrhea and secondary dysmenorrhea.<sup>229,230,231,232</sup> Hormonal contraceptive implants, such as the single-rod implantable hormonal contraceptive containing etonogestrel (Implanon), have also shown benefit.<sup>233</sup>

Women who fail to respond to treatment with NSAIDs and/or hormonal contraceptives and those having recurrent or worsening pain merit re-evaluation to exclude causes of secondary dysmenorrhea, such as endometriosis.<sup>208</sup> In a study of women with pelvic pain who failed to obtain adequate relief from treatment with NSAIDs, the large majority had demonstrable endometriosis at laparoscopy.<sup>234</sup> These observations suggest that women with severe dysmenorrhea who fail to respond adequately to treatment with NSAIDs or oral contraceptives are candidates for diagnostic laparoscopy. Women with endometriosis should have their disease ablated, to the extent possible. Postoperative treatment with a GnRH agonist (e.g., leuprolide acetate depot 3.75 mg every 4 weeks) is effective for the management of those (with or without endometriosis) who have persistent dysmenorrhea. Although empirical

treatment with GnRH agonists, based on clinical criteria,<sup>234</sup> has been promoted as an alternative to surgery in women having a high likelihood of endometriosis, surgical treatment offers the advantages of a specific diagnosis, immediate pain relief, and better informed longer-term management.

# MENSTRUAL MIGRAINE

Headaches are very common, but the cause is rarely serious. Most headaches result from vasodilation, muscle contraction, or psychological stress. Menstrual headaches include all headaches that are temporally related to menses, beginning before or during menstruation (Figure 14.6).<sup>235</sup> For many women with PMS, headache is part of their cyclic symptom complex. The focus here is on pure menstrual migraine, describing headaches that occur exclusively in association with menses, and on “menstrually related migraine,” describing patients who have migraines with menses but also at other times in the cycle, such as in the middle of cycle, soon after ovulation.<sup>236</sup>

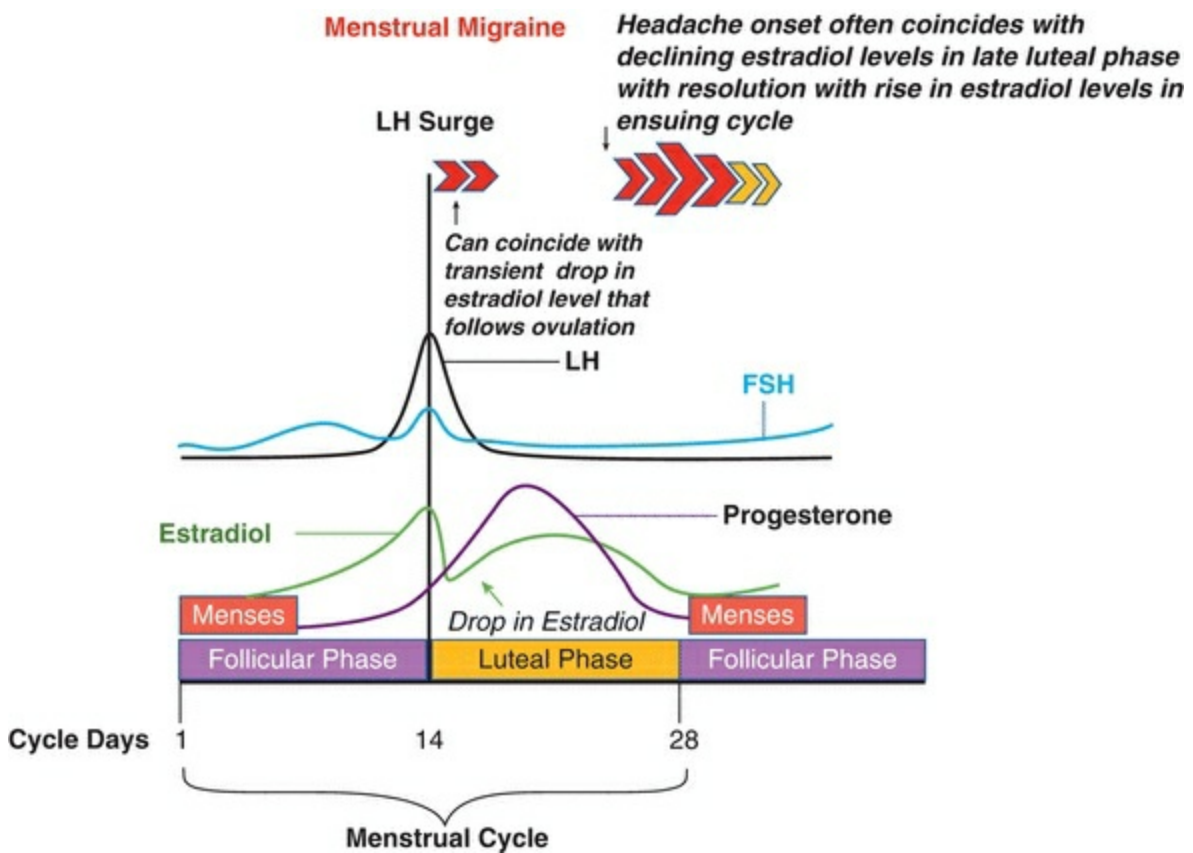


FIGURE 14.6

# Pathophysiology

The traditional “vascular theory,” holding that migraine and cluster headaches result from vasodilation and the preceding aura from vasoconstriction, is no longer considered viable.<sup>237</sup> Instead, vasodilation is probably an epiphenomenon that results from instability in central neurovascular control. **Current concepts of the pathophysiology of migraine center on the trigeminovascular system.** The large cerebral vessels, those of the pia and dura mater, and the large venous sinuses are innervated by sensory afferents originating from the trigeminal ganglion and upper cervical dorsal roots.<sup>238</sup> The two converge at the trigeminal nucleus caudalis, explaining the distribution of migraine pain, which typically involves the front and back of the head and upper neck. When the trigeminal ganglion is stimulated, vasoactive neuropeptides (substance P, calcitonin gene-related peptide, neurokinin) are released,<sup>239</sup> causing neurogenic inflammation, which results in vasodilation, extravasation of plasma proteins, and pain. In turn, neurogenic inflammation may cause sensitization, describing a process in which neuronal response thresholds decrease, the magnitude of response increases, and receptive fields expand.<sup>240,241,242</sup> The sensitization phenomenon helps to explain some of the clinical symptoms of migraine, which include a worsening with coughing or bending, hyperalgesia (increased sensitivity to painful stimuli), and allodynia (pain caused by normally nonpainful stimuli). The classical aura associated with migraine headaches (visual or auditory symptoms, nausea or vomiting, paresthesias) is attributed to “cortical spreading depression,” describing a self-propagating wave of neuronal and glial depolarization that spreads across the cerebral cortex.<sup>237</sup> Migraine without aura may involve areas of the brain where depolarization is not consciously perceived.<sup>243</sup>

The incidence of migraine headache increases significantly between the ages of 15 and 19 years, peaks in women in their late 30s to early 40s, and falls after menopause.<sup>244,245,246,247</sup> Up to 70% of women with migraine headaches observe an association with menses; 7–21% have pure menstrual migraine and the remainder has menstrually related migraines.<sup>248</sup> Compared with headaches that occur at other times of the month, menstrual migraines usually are more resistant to treatment, generally not associated with aura, of longer duration, and associated with more functional disability.<sup>249,250,251,252</sup>

The association between changes in the clinical course of migraine headaches and reproductive milestones, such as menarche, pregnancy, and menopause, suggests that ovarian steroid hormones are involved in their pathophysiology. Migraine appears to be associated with declining hormone levels, as occurs at the end of the normal menstrual cycle, postpartum, and during scheduled pill-free weeks in women using oral contraceptives.<sup>253,254</sup> **Biochemical and genetic evidence suggests that menstrual**



**migraine is triggered primarily by declining estrogen levels.** Estrogen has a number of actions within the central nervous system. Its effects on the serotonergic neurotransmitter system, in particular, may explain its association with migraine.<sup>248</sup> In women, serotonergic tone correlates with estrogen levels; when estrogen levels decline, serotonin concentrations also fall, due both to a decrease in production and to an increase in clearance. Estrogen also may modulate the balance between excitatory and inhibitory neurotransmission via its effects on other chemical mediators, such as nitric oxide, magnesium, or prostaglandins.<sup>248,255</sup>

# Evaluation

Although headaches are common, they also can be an indication of a serious condition, such as an intracranial space-occupying mass, vascular lesion, infection, or a metabolic disease. Chronic headaches should be characterized according to their location, quality, changes over time, and associated symptoms and signs.

Common tension-type headaches are classified as episodic (<15 per month) or chronic ( $\geq 15$  per month).<sup>256</sup> Tension-type headaches were named originally for their suspected cause, excessive stress or tension, resulting in muscle contraction, but that traditional explanation is no longer considered viable.<sup>257</sup> Although their pathogenesis remains unclear, current models center on heightened sensitivity of pain pathways in the central nervous system and possibly in the peripheral nervous system,<sup>258,259,260</sup> nitric oxide,<sup>261</sup> and genetic factors.<sup>262,263</sup> Tension-type headaches generally are mild to moderate in intensity, are bilateral, and usually are described as “dull,” “pressure,” “a tight cap,” “band-like,” or a sense of weight on the head and shoulders. They can vary in intensity and frequency, but generally do not exhibit progression over time.

When headaches are cyclic, completely absent for periods of time, and exhibit characteristic features, they generally can be ascribed comfortably to migraine. **Migraines are characteristically throbbing in nature, frequently but not always are preceded by a prodrome, and typically begin slowly, rising to a crescendo over 1–2 hours. Most patients with migraines have had numerous similar headaches in the past.** Migraines can be precipitated by stress, alcohol, or tyramine- and tryptophan-rich foods (e.g., red wine, chocolate, ripe cheeses). Classic migraine is now known as “migraine with aura” and common migraine as “migraine without aura.” **Menstrual migraine headaches typically are migraines without aura.**<sup>247</sup>

**Headaches that are sudden in onset, persistent headaches that worsen over time, and those that become severe shortly after their onset or are associated with changes in mental status warrant careful and thorough evaluation.** Focal neurologic symptoms, other than a typical visual or sensory aura, suggest a mass lesion, arteriovenous malformation, or collagen vascular disease. Fever is not a characteristic of migraine headache and suggests an intracranial, systemic, or local infection (e.g., paranasal or mastoid sinusitis). New headaches in women over 50 or in patients with cancer or human immunodeficiency virus (HIV) infection suggest pathology. Chronic nasal congestion suggests sinusitis. Blurred vision, headaches upon waking in the morning that improve after sitting or standing, double vision or loss of balance, and worsening headaches associated with chronic nausea suggest increased intracranial pressure. Sudden unilateral loss of vision suggests optic neuritis. **Brain imaging generally is indicated for patients having a recent significant change in the pattern,**

**frequency, or severity of headaches, worsening headaches despite treatment, focal neurologic symptoms or signs, or an onset of headaches with exertion or after the age of 40 years.**<sup>264</sup>

# Treatment

The treatment for acute menstrual migraine is similar to that for common migraine; serotonin agonists (known as triptans), such as sumatriptan (50–100 mg), rizatriptan (10 mg), and frovatriptan (2.5 mg), are effective in aborting migraine headaches.<sup>265,266,267</sup> Triptans inhibit the release of vasoactive peptides, promote vasoconstriction, and inhibit neurotransmission in the trigeminal nucleus, which blocks afferent input to second-order neurons. They also help in relieving associated nausea and photophobia. When acute abortive therapy is required repeatedly or proves inadequate, prevention strategies, both hormonal and nonhormonal, merit consideration.

Hormonal prevention therapies are aimed at minimizing or eliminating the premenstrual decline in serum estrogen levels.<sup>268</sup> They are a logical choice for patients with other menstrual pathology, such as irregular cycles, dysmenorrhea, or menorrhagia, and generally are preferred over nonhormonal prevention therapies. If menstrual migraines represent a reaction to cyclic changes in circulating levels of sex steroid hormones, it's logical to try to minimize or eliminate cyclicality, which can be achieved with continuous, daily oral contraceptives. For women who prefer to have menses, extended cycle oral contraceptives containing 9–12 consecutive weeks of active pills greatly reduce their frequency; standard formulations also can be used, but in either case, estrogen supplementation should be provided during any scheduled placebo week to prevent the estrogen withdrawal migraine.<sup>269</sup> The use of oral contraceptives in women who have migraine with aura has been controversial due to concerns about a potential increase in the risk for stroke. Whereas European studies have suggested that oral contraceptives may increase the risk,<sup>270,271,272</sup> American studies have not,<sup>273,274</sup> probably because low-dose pills are more prevalent and smoking over age 35 has been regarded as a relatively strong contraindication to use of oral contraceptives in the United States (discussed in detail in [Chapter 22](#)). Nonetheless, both the World Health Organization and the American College of Obstetricians and Gynecologists currently discourage the use of oral contraceptives in women over age 35 whose migraines are associated with focal neurologic symptoms or signs.

In women with contraindications to use of oral contraceptives, estrogen supplementation still can be used to buffer the decline in estrogen levels at the end of the cycle, beginning just before the onset of menses and continuing for a total of approximately 7 days. In clinical trials, a transdermal estradiol patch (0.1 mg/day) or gel (1.5 mg/day) was effective<sup>275,276</sup> but must be continued until endogenous estrogen levels rise again or treatment merely postpones estrogen withdrawal and related migraine.<sup>276</sup> A long-acting GnRH agonist is another alternative. Clinical studies in women with menstrual migraine indicate that treatment with leuprolide acetate can

decrease markedly the frequency of headaches, even when add-back estrogen/progestin treatment is provided.<sup>277,278</sup>

The prevalence of migraine is relatively high during the perimenopause, especially in women with a history of menstrual migraine.<sup>279</sup> In the Women's Health Study, 11% of more than 17,000 postmenopausal female health professionals reported migraine; current users of hormone therapy were more often affected than never users (OR = 1.42; 95% CI = 1.24–1.62) and prevalence correlated with the dose of estrogen therapy.<sup>280</sup> **The treatment of migraine in menopausal women is not different from that in premenopausal women.** Again, hormone regimens that minimize changes in circulating estrogen levels are preferable; therefore, continuous treatment is a better choice than cyclic therapy. Addition of a progestin, when needed, does not affect the frequency of migraines.<sup>280</sup>

Nonhormonal therapies for menstrual migraines include treatment with an NSAID or a triptan. Treatment with NSAIDs, beginning 7 days before onset and continuing through the end of menses, can help to decrease the frequency, duration, and severity of menstrual migraine.<sup>281</sup> Triptan treatment, beginning 2–3 days before menses and continuing for a total of 5–6 days, effectively prevents or decreases the severity of headaches in the majority of patients. Proven regimens include sumatriptan 25 mg 3 times daily,<sup>282</sup> naratriptan 1 mg twice daily,<sup>283</sup> and frovatriptan 2.5 mg daily or twice daily.<sup>284</sup>

The newest class of agents for preventive treatment of migraine target calcitonin gene-related peptide (CGRP) signaling. Erenumab is a monoclonal antibody to CGRP receptor that has recently been approved in the United States for the preventive treatment of migraine in adults<sup>285</sup>; efficacy of this class of drugs against menstrual migraines is, however, yet to be demonstrated.

# CATAMENIAL EPILEPSY

---

In ancient times, catamenial epilepsy was attributed to the moon, giving rise to the word, “lunatic.”<sup>286</sup> The word, “catamenial,” derives from the Greek word katomenios, meaning “monthly.” Catamenial epilepsy describes seizures that are clustered around specific points in the menstrual cycle, usually during the perimenstrual or periovulatory intervals. **The diagnosis of catamenial epilepsy is based on demonstrating the temporal relationship between menstruation and seizure activity; a twofold or greater increase in seizure frequency during a particular phase of the menstrual cycle generally is considered as evidence of catamenial epilepsy.**<sup>287,288</sup> Based on that definition, catamenial epilepsy affects from 30% to 60% of women with epilepsy.<sup>289,290,291</sup> Given that epilepsy affects an estimated 1.3 million women in the United States,<sup>292,293</sup> approximately 400,000 women with epilepsy experience catamenial seizures, which often are quite resistant to treatment.<sup>294</sup>

# Pathophysiology

Catamenial seizures are associated with every type of epilepsy but are more common among women with focal epilepsy (e.g., temporal lobe epilepsy) than in those with generalized epilepsy.<sup>295</sup> Their specific cause is still unclear. Hypotheses include fluctuations in antiepileptic drug levels, changes in water and electrolyte balance, and variations in ovarian steroid hormone secretion.<sup>288</sup> Cyclic changes in estrogen and progesterone across the menstrual cycle are widely regarded as playing a central role. There are three recognized patterns that relate to timing of occurrence of seizures in the menstrual cycle: perimenstrual, periovulatory, and inadequate luteal (in anovulatory cycles).<sup>296</sup>

**Estrogens generally are considered as proconvulsant, although their effects depend on the duration of treatment, dosage, the mode of administration, and the seizure model.** Estrogens affect neuronal excitability via modulation of gene expression, regulation of neurotransmitter release, and direct interaction with neurotransmitter receptors. Estrogen acts on neurons within the limbic system, cerebral cortex, and other regions important for seizure susceptibility.<sup>297</sup> Estrogen also interacts with neurotrophins, which enhance hippocampal excitability. In women with epilepsy, seizure susceptibility correlates with the estrogen/progesterone ratio, which peaks in the premenstrual and preovulatory intervals. Although serum estradiol concentrations in women with catamenial epilepsy are similar to those in normal controls across the menstrual cycle, evidence suggests that progesterone levels are lower and estrogen/progesterone ratios are higher.<sup>291,298</sup> Seizure frequency decreases during the midluteal phase when progesterone levels are highest and increases in the premenstrual phase when progesterone levels fall and the estrogen/progesterone ratio increases.

**Progesterone generally is considered to have an anticonvulsant action, by lowering seizure susceptibility.** Changes in serum progesterone levels have been correlated directly with catamenial seizures,<sup>291,298</sup> and evidence from studies in mice supports the concept that 5 $\alpha$ -reduced metabolites of progesterone, particularly allopregnanolone, are responsible for its antiseizure activity.<sup>288,299</sup> Neurosteroids like allopregnanolone are synthesized locally within the brain, both de novo and from circulating steroid precursors, and modulate neural excitability. Allopregnanolone potentiates the action of GABA, the major inhibitory neurotransmitter in the brain, via modulation and direct interaction with GABA-A receptors.<sup>300</sup>

The interactions between gonadal steroid hormones, seizures, and antiepileptic drugs are complex. Whereas gonadal steroid hormones can affect seizure susceptibility, seizures may disrupt patterns of steroid hormone secretion, and antiepileptic drugs can affect sex steroid hormone levels by altering their metabolism. In adolescents with

epilepsy, the incidence of generalized tonic-clonic seizures often increases during puberty,<sup>301</sup> when the levels of steroid hormones increase and menses begin. At menopause, seizure activity increases in some women but decreases or remains unchanged in others.<sup>302,303,304</sup> Hormone therapy can increase seizure activity in postmenopausal women, particularly in those having a history of catamenial epilepsy.<sup>305,306</sup> On the other hand, the prevalence of menstrual disorders such as polycystic ovary syndrome is increased,<sup>307</sup> and fertility is decreased among women with epilepsy,<sup>308</sup> suggesting that seizures may predispose to reproductive dysfunction, possibly by altering the pattern of hypothalamic GnRH release. The association between epilepsy and reproductive dysfunction also might reflect the effects of antiepileptic drugs on steroid hormone metabolism. Some, such as phenytoin, carbamazepine, and phenobarbital, induce hepatic cytochrome P450 enzymes, which can accelerate the metabolism of steroid hormones that share common metabolic pathways.<sup>309,310</sup> They also can increase serum SHBG concentrations, thereby further decreasing the concentrations of free or biologically active steroids. Other antiepileptic drugs, such as sodium valproate, inhibit hepatic enzymes, which may increase bioactive steroid hormone levels. However, there is no direct evidence linking catamenial epilepsy with specific antiepileptic drugs. The extent to which all of these competing mechanisms contribute to catamenial epilepsy remains to be determined.

Some studies have suggested that oral contraceptives might increase seizure activity, but most have observed no effect<sup>305,311,312</sup> or a decrease in seizure frequency.<sup>313,314</sup> Although certain antiepileptic drugs have the potential to reduce the efficacy of oral contraceptives by accelerating their metabolism,<sup>305,315</sup> there is no evidence the effect is clinically important.<sup>316,317,318,319</sup> Conversely, oral contraceptives can decrease circulating concentrations of some antiepileptic drugs via the same mechanism, which may increase the risk of seizures<sup>320</sup>; evidence indicates that women receiving treatment with lamotrigine or valproic acid may need dosage adjustments if also using oral contraceptives.<sup>319,321,322</sup>



# Treatment

Antiepileptic drugs are the mainstay in the management of catamenial epilepsy. However, approximately one-third of women with catamenial seizures require treatment with more than one drug, partly because catamenial epilepsy often proves refractory to conventional medications. At least in theory, gabapentin, levetiracetam, tiagabine, zonisamide, and pregabalin are attractive choices, because they do not induce hepatic enzymes. Acetazolamide, a potent inhibitor of carbonic anhydrase, has been used empirically for years in the treatment of catamenial epilepsy, but there are few direct studies attesting to its effectiveness<sup>324</sup>; drug tolerance, requiring progressive dosage escalation, is a common problem. Benzodiazepines, such as clonazepam and clobazam, increase GABA-A receptor activity and have broad-spectrum antiseizure activity. Clobazam (20–30 mg daily), administered intermittently from 2 to 4 days before menses through the first 3 days of bleeding, has proven effective for the treatment of catamenial epilepsy; intermittent treatment helps to avoid problems with tolerance, which otherwise is common.<sup>325</sup> Limited evidence suggests that treatment with lamotrigine (25–200 mg daily) can decrease or eliminate catamenial seizures, at least in some women.<sup>326</sup> Ganaxolone, a synthetic neurosteroid (a 3 $\beta$ -methyl analog of allopregnanolone) that has shown promise in preclinical models of catamenial epilepsy and preliminary investigations in women,<sup>327</sup> is now in clinical trials.<sup>328</sup>

Hormonal therapies for the management of catamenial seizures also deserve consideration, particularly for women who prove resistant to antiepileptic drugs. Treatment with depot medroxyprogesterone acetate in doses that typically eliminate menses (e.g., 150 mg intramuscularly every 3 months) can improve seizure control in many women.<sup>329</sup> Cyclic natural progesterone also has been demonstrated effective for the treatment of catamenial seizures; 100–200 mg, administered orally or vaginally 3 times daily between days 15 and 28 of the cycle, decreased seizure frequency by approximately 50–75%.<sup>330,331</sup> A randomized controlled trial that was sponsored by the National Institute of Health in the United States compared bioidentical progesterone with placebo in the treatment of focal onset epilepsy. While progesterone was no better than placebo against seizures, subgroup analyses identified benefit of progesterone in women specifically experiencing perimenstrual exacerbation of seizure activity.<sup>332,333</sup> Evidence from studies in animal models and clinical data suggest the antiseizure effects of progesterone derive from its metabolic conversion to neurosteroids, primarily allopregnanolone.<sup>334,335</sup> Continuous oral contraceptives, the progestin-only minipill,<sup>336</sup> and GnRH agonists with add-back estrogen/progestin therapy also have demonstrated some effectiveness in small numbers of women with catamenial epilepsy.<sup>337,338,339</sup>

In sum, catamenial epilepsy is a complex and multifaceted condition. Ovarian

hormones play a central role but the exact cause is unknown. Evidence indicates that estrogen, progesterone, and endogenous neurosteroids are involved in its pathophysiology, but no specific hormonal dynamic predisposing to seizures has been identified. Neurosteroid withdrawal may be the critical factor that increases seizure susceptibility during the perimenstrual interval, acting via changes in central GABA-A receptors. Conventional antiepileptic drugs are not effective in most patients with catamenial seizures, possibly because they can alter sex steroid concentrations and metabolism. Hormonal therapies, such as progesterone, oral contraceptives, and GnRH agonists, have proven efficacy. Finally, newly developed synthetic neurosteroids have shown considerable promise in animal studies of catamenial epilepsy and may offer a specific treatment in the future.

# PREMENSTRUAL ASTHMA

---

Approximately 20–40% of women with asthma have an increase in symptoms associated with menstruation.<sup>340,341,342</sup> Even asthmatics not aware of a link to menses demonstrate a worsening of pulmonary function during menstruation.<sup>343,344</sup> Women with hormonally triggered asthma generally tend to have more severe asthma than those whose asthma is not affected by changes in hormones. The mechanism is unknown, but prostaglandin release, changes in the immune system, and a direct effect of declining estrogen and progesterone levels on bronchial smooth muscle all have been suggested.

The best method for treating premenstrual asthma has not been established. Treatment with estrogen (micronized estradiol, 2 mg orally daily) has been reported to improve symptoms and measures of pulmonary function.<sup>344</sup> A randomized clinical trial found no difference between the effects of estrogen and placebo, although the subjects all had mild asthma generally under good control.<sup>345</sup> Another study found that administration of intramuscular progesterone helped to ameliorate premenstrual asthma.<sup>346</sup> The logic of eliminating menstrual periods by daily treatment with oral contraceptives, intramuscular depot medroxyprogesterone acetate, or treatment with a long-acting GnRH agonist is tempting, but there are no available data demonstrating their efficacy. Alternatives include a rescue inhaler, when necessary, or a leukotriene modifier, such as montelukast, zafirlukast, or zileuton.

# CATAMENIAL PNEUMOTHORAX, HEMOTHORAX, AND HEMOPTYSIS

---

Thoracic endometriosis syndromes are closely linked to the presence of pelvic endometriosis. In a retrospective analysis of 110 cases, the mean age at presentation of thoracic endometriosis was  $35 \pm 0.6$  years, with a range from 15 to 54 years.<sup>347</sup> Catamenial pneumothorax was the most common presentation, occurring in 80/110 patients (73%); catamenial hemothorax occurred in 15 (14%), catamenial hemoptysis occurred in 8 (7%), and lung nodules were observed in 7 (6%). Fifty-one of sixty-one patients who underwent laparoscopy or laparotomy had evidence of pelvic endometriosis. Pleural implants were observed in less than 15% of those who had thoracostomy or thoracotomy, and diaphragmatic defects, parenchymal cysts, or blebs were observed in approximately 25% of cases.<sup>347</sup>

The most plausible explanations for catamenial pneumothorax, hemothorax, and hemoptysis are peritoneal to pleural transfer of endometrial tissue through diaphragmatic defects<sup>348,349</sup> and microembolization through pelvic veins.<sup>347</sup> A review of 154 cases of catamenial pneumothorax treated surgically found that 16% of patients had demonstrable diaphragmatic perforations in the absence of thoracic endometriosis and 12% had visible diaphragmatic endometriosis associated with one or more perforations.<sup>350</sup>

In affected women, symptoms of thoracic endometriosis typically arise within 24–48 hours after the onset of menses. Chest pain is the most common symptom, occurring in 90% of patients, and one-third have dyspnea. Pneumothorax occurs most commonly on the right side and usually is small to moderate in size; hemothorax also usually is right sided.<sup>351,352</sup> Women with endobronchial or pulmonary parenchymal endometriosis usually present with catamenial hemoptysis.

The diagnosis of thoracic endometriosis should be suspected in reproductive-aged women presenting with recurrent chest pain, pneumothorax, or hemoptysis during menses. Although not required, diagnosis can be established by pleural fluid cytology,<sup>353</sup> needle aspiration of lung masses,<sup>354</sup> cytology performed on bronchoscopic aspirations,<sup>355</sup> or video thoracoscopy.<sup>356</sup> In a systematic review of 182 women with catamenial pneumothorax who underwent video-assisted thoracoscopic surgery, endometrial implants were noted in 59% and 57% had evidence of diaphragmatic perforations. Pelvic endometriosis was reported in 39.5%. Notably, those with diagnosed pelvic endometriosis showed a significantly higher rate of thoracic endometrial implants and histologically confirmed endometriosis lesions than patients without pelvic endometriosis.<sup>355</sup> In women with catamenial pneumothorax, chest

computerized tomography (CT) can reveal bullae, cavities, or fibrosis and, in those with hemoptysis, can demonstrate small parenchymal nodules, which may be visible only during the menstrual phase of the cycle.<sup>358,359</sup>

The initial treatment of patients with symptomatic thoracic endometriosis is the same as for others with pneumothorax, hemothorax, or hemoptysis. Longer-term, successful treatment requires suppression or excision of thoracic endometrial implants, prevention of re-seeding from the pelvis, and prevention of air leakage across diaphragmatic perforations. Although hormonal suppressive treatments (e.g., oral contraceptives, progestins, danazol, GnRH analogs) generally are considered first-line therapy, the recurrence rate is greater than 50%.<sup>347</sup> When they fail, surgical treatment is indicated. Direct inspection of the pleura via video thoracoscopy or thoracotomy can identify diaphragmatic endometrial implants or perforations, which can be excised or closed, usually followed by chemical pleurodesis using talc poudrage (blowing powder or an aerosol into the pleural cavity) or pleural abrasion.<sup>350,352</sup> Surgical treatments generally are very effective for preventing recurrent catamenial pneumothorax or hemothorax, but some who continue to have cyclic chest pain due to pleuropulmonary implants may require longer-term medical suppressive therapy.<sup>360</sup>

# VASOVAGAL SYNCOPE

---

Vasovagal syncope (VVS) is a disorder of autonomic regulation, in which sudden postural changes contribute to transient global cerebral hypoperfusion that results in brief loss of consciousness.<sup>361,362</sup> VVS is much more common in women than men, and in some women, the frequency of episodes is higher in the menstrual phase.<sup>363</sup> In a prospective study, the occurrence of syncope induction by head-up tilt test (HUTT) differed by the phase of menstrual cycle (follicular and luteal), among premenopausal women; a vasodepressive type of vasovagal syndrome occurred more often in follicular than in luteal phase.<sup>364</sup> Others have failed to identify any relevance of timing of menstrual cycles on results of tilt table test.<sup>365</sup> Notably, provoked responses did not differ between pre and postmenopausal women.<sup>364</sup>

# REFERENCES

1. **Golub S**, *Periods, from Menarche to Menopause*, Sage Publications, Newbury Park, 1992.
2. **Secundus Plinius C**, *Historia Naturalis*, Southern Illinois Press, 1962.
3. **d'Orban PT**, Medicolegal aspects of the premenstrual syndrome, *Br J Hosp Med* 30(6):404, 1983.
4. **Dalton K**, *The Premenstrual Syndrome and Progesterone Therapy*, 2nd ed, Yearbook Medical Publishers, Inc., Chicago, 1984.
5. **Sommer B**, The effect of menstruation on cognitive and perceptual-motor behavior: a review, *Psychosom Med* 35:515, 1973.
6. **Gannon FL**, Evidence for a psychological etiology of menstrual disorders: a critical review, *Psychol Rep* 48:287, 1981.
7. **Morgan M, Rapkin AJ, D'Elia L, Reading A, Goldman L**, Cognitive functioning in premenstrual syndrome, *Obstet Gynecol* 88:961, 1996.
8. **Walsh RM, Budtz-Olsen I, Leader C, Cummins RA**, The menstrual cycle, personality, and academic performance, *Arch Gen Psychiatry* 38:219, 1981.
9. **Steiner M, Born L**, Diagnosis and treatment of premenstrual dysphoric disorder: an update, *Int Clin Psychopharmacol* 15(Suppl 3):S5, 2000.
10. **Greene R, Dalton K**, The premenstrual syndrome, *Br Med J* 1:1007, 1953.
11. **Frank RT**, The hormonal causes of premenstrual tension, *Arch Neurol Psychiatry* 26:1052, 1931.
12. **Mortola JF, Girton L, Beck L, Yen SS**, Diagnosis of premenstrual syndrome by a simple prospective and reliable instrument: the calendar of premenstrual experiences, *Obstet Gynecol* 76:302, 1990.
13. **Rubinow DR, Roy-Byrne P**, Premenstrual syndromes: overview from a methodologic perspective, *Am J Psychiatry* 141:2, 1984.
14. **Brooks J, Ruble D, Clark A**, College women's attitudes and expectations concerning menstrual-related changes, *Psychosom Med* 39:288, 1977.
15. **Ruble DN**, Premenstrual symptoms: a reinterpretation, *Science* 197:291, 1977.
16. **Vila J, Breech HR**, Premenstrual symptomatology: an interaction hypothesis, *Br J Soc Clin Psychol* 19:73, 1980.
17. **AuBuchon PG, Calhoun KS**, Menstrual cycle symptomatology: the role of social expectancy and experimental demand characteristics, *Psychosom Med* 47:35, 1985.
18. **Olasov B, Jackson J**, Effects of expectancies on women's reports of moods during the menstrual cycle, *Psychosom Med* 49:65, 1987.
19. **Resnick A, Perry W, Parry B, Mostofi N, Udell C**, Neuropsychological performance across the menstrual cycle in women with and without premenstrual dysphoric disorder, *Psychiatry Res* 77:147, 1998.
20. **Morgan M, Rapkin A**, Cognitive flexibility, reaction time, and attention in women with premenstrual dysphoric disorder, *J Gend Specif Med* 5:28, 2002.
21. **Deuster PA, Adera T, South-Paul J**, Biological, social, and behavioral factors associated with premenstrual syndrome, *Arch Fam Med* 8:122, 1999.
22. **Borenstein J, Chiou CF, Dean B, Wong J, Wade S**, Estimating direct and indirect costs of premenstrual syndrome, *J Occup Environ Med* 47:26, 2005.
23. **Rivera-Tovar AD, Frank E**, Late luteal phase dysphoric disorder in young women, *Am J Psychiatry* 147:1634, 1990.
24. **Soares CN, Cohen LS, Otto MW, Harlow BL**, Characteristics of women with premenstrual dysphoric disorder (PMDD) who did or did not report history of depression: a preliminary report from the Harvard Study of Moods and Cycles, *J Womens Health Gend Based Med* 10:873, 2001.
25. **Mortola JF**, Issues in the diagnosis and research of premenstrual syndrome, *Clin Obstet Gynecol* 35:587, 1992.
26. **Bailey JW, Cohen LS**, Prevalence of mood and anxiety disorders in women who seek treatment for premenstrual syndrome, *J Womens Health Gend Based Med* 8:1181, 1999.

27. **Mortola JF, Girton L, Yen SS**, Depressive episodes in premenstrual syndrome, *Am J Obstet Gynecol* 161:1682, 1989.
28. **Jelley MJ, Mutzig EM, Walsh J**, Women, In: **Feldman MD, Christensen JF**, eds. *Behavioral Medicine in Primary Care: A Practical Guide*, McGraw-Hill Companies, Inc., New York, 2003, p. 127.
29. **Lorr M, McNair DM, Fisher SU**, Evidence for bipolar mood states, *J Pers Assess* 46:432, 1982.
30. **Beck AT, Ward CH, Mendelson M, Mock J, Erbaugh J**, An inventory for measuring depression, *Arch Gen Psychiatry* 4:561, 1961.
31. **Moos RH**, The development of a menstrual distress questionnaire, *Psychosom Med* 30:853, 1968.
32. **Halbreich U, Endicott J, Schacht S, Nee J**, The diversity of premenstrual changes as reflected in the Premenstrual Assessment Form, *Acta Psychiatr Scand* 65:46, 1982.
33. **Halbreich U, Endicott J, Lesser J**, The clinical diagnosis and classification of premenstrual changes, *Can J Psychiatry* 30:489, 1985.
34. **Reid RL**, Premenstrual syndrome, *Curr Prob Obstet Gynecol Fertil* 8:1, 1985.
35. **Borenstein JE, Dean BB, Yonkers KA, Endicott J**, Using the daily record of severity of problems as a screening instrument for premenstrual syndrome, *Obstet Gynecol* 109(5):1068, 2007.
36. **Steiner M, Macdougall M, Brown E**, The premenstrual symptoms screening tool (PSST) for clinicians, *Arch Womens Ment Health* 6(3):203, 2003.
37. **Osofsky JH, Blumenthal SJ**, eds. *Premenstrual Syndrome: Current Findings and Future Directions*, American Psychiatric Press, Washington, 1985.
38. **Ramacharan S, Love EJ, Fick GH, Goldfien A**, The epidemiology of premenstrual symptoms in a population based sample of 2650 urban women, *J Clin Epidemiol* 45:377, 1992.
39. **Merikangas KR, Foeldenyi M, Angst J**, The Zurich Study. XIX. Patterns of menstrual disturbances in the community: results of the Zurich Cohort Study, *Eur Arch Psychiatry Clin Neurosci* 243:23, 1993.
40. **Wittchen HU, Becker E, Lieb R, Krause P**, Prevalence, incidence and stability of premenstrual dysphoric disorder in the community, *Psychol Med* 32:119, 2002.
41. **American Psychiatric Association**, *Diagnostic and Statistical Manual of Mental Disorders*, 5th ed, American Psychiatric Association, Washington, 2013.
42. **Pearlstein TB, Frank E, Rivera-Tovar A, Thoft JS, Jacobs E, Mieczkowski TA**, Prevalence of axis I and axis II disorders in women with late luteal phase dysphoric disorder, *J Affect Disord* 20:129, 1990.
43. **Endicott J**, The menstrual cycle and mood disorders, *J Affect Disord* 29:193, 1993.
44. **Plouffe L Jr, Stewart K, Craft KS, Maddox MS, Rausch JL**, Diagnostic and treatment results from a southeastern academic center-based premenstrual syndrome clinic: the first year, *Am J Obstet Gynecol* 169:295, 1993.
45. **Bancroft J, Rennie D, Warner P**, Vulnerability to perimenstrual mood change: the relevance of a past history of depressive disorder, *Psychosom Med* 56:225, 1994.
46. **Graze KK, Nee J, Endicott J**, Premenstrual depression predicts future major depressive disorder, *Acta Psychiatr Scand* 81:201, 1990.
47. **American College of Obstetricians and Gynecologists**, *Premenstrual Syndrome*. ACOG Practice Bulletin 15, American College of Obstetricians and Gynecologists, Washington, 2000.
48. **Israel SL**, Premenstrual tension, *JAMA* 110:1721, 1934.
49. **Casson P, Hahn PM, Van Vugt DA, Reid RL**, Lasting response to ovariectomy in severe intractable premenstrual syndrome, *Am J Obstet Gynecol* 162:99, 1990.
50. **Casper RF, Hearn MT**, The effect of hysterectomy and bilateral oophorectomy in women with severe premenstrual syndrome, *Am J Obstet Gynecol* 162:105, 1990.
51. **Mortola JF, Girton L, Fischer U**, Successful treatment of severe premenstrual syndrome by combined use of gonadotropin-releasing hormone agonist and estrogen/progestin, *J Clin Endocrinol Metab* 71:252, 1991.
52. **Hussain SY, Massil JH, Matta WH, Shaw RW, O'Brien PMS**, Buserelin in premenstrual syndrome, *Gynecol Endocrinol* 6:57, 1992.
53. **Brown CS, Ling FW, Andersen RN, Farmer RG, Arheart KL**, Efficacy of depot leuprolide in premenstrual syndrome: effect of symptom severity and type in a controlled trial, *Obstet Gynecol* 84:779, 1994.



54. **Budeiri DJ, Li Wan Po A, Dornan JC**, Clinical trials of treatments of premenstrual syndrome: entry criteria and scales for measuring treatment outcomes, *Br J Obstet Gynaecol* 101:689, 1994.
55. **Andersch B, Abrahamsson L, Wendestam C, Ohman R, Hahn L**, Hormone profile in premenstrual tension: effects of bromocriptine and diuretics, *Clin Endocrinol (Oxf)* 11:657, 1979.
56. **Taylor JW**, Plasma progesterone, oestradiol 17 beta and premenstrual symptoms, *Acta Psychiatr Scand* 60:76, 1979.
57. **Schmidt PJ, Purdy RH, Moore PH Jr, Paul SM, Rubinow DR**, Circulating levels of anxiolytic steroids in the luteal phase in women with premenstrual syndrome and in control subjects, *J Clin Endocrinol Metab* 79:1256, 1994.
58. **Schmidt PJ, Nieman LK, Grover GN, Muller KL, Merriam GR, Rubinow DR**, Lack of effect of induced menses on symptoms in women with premenstrual syndrome, *N Engl J Med* 324:1174, 1991.
59. **Chan AF, Mortola JF, Wood SH, Yen SS**, Persistence of premenstrual syndrome during low-dose administration of the progesterone antagonist RU 486, *Obstet Gynecol* 84:1001, 1994.
60. **Schmidt PJ, Nieman LK, Danaceau MA, Adams LF, Rubinow DR**, Differential behavioral effects of gonadal steroids in women with and in those without premenstrual syndrome, *N Engl J Med* 338:209, 1998.
61. **Rubinow DR, Schmidt PJ**, Premenstrual syndrome: a review of endocrine studies, *Endocrinologist* 2:47, 1992.
62. **Wardlaw SL, Thoron L, Frantz AG**, Effects of sex steroids on brain beta-endorphin, *Brain Res* 245:327, 1982.
63. **Majewska MD, Harrison NL, Schwartz RD, Barker JL, Paul SM**, Steroid hormone metabolites are barbiturate-like modulators of the GABA receptor, *Science* 232:1004, 1986.
64. **Bethea CL**, Regulation of progestin receptors in raphe neurons of steroid-treated monkeys, *Neuroendocrinology* 60:50, 1994.
65. **Chuong CJ, Coulam CB, Kao PC, Bergstralh EJ, Go VL**, Neuropeptide levels in premenstrual syndrome, *Fertil Steril* 44:760, 1985.
66. **Chuong CJ, Hsi BP, Gibbons WE**, Periovulatory beta-endorphin levels in premenstrual syndrome, *Obstet Gynecol* 83:755, 1994.
67. **Giannini AJ, Martin DM, Turner CE**, Beta-endorphin decline in late luteal phase dysphoric disorder, *Int J Psychiatry Med* 20:279, 1990.
68. **Smith S, Rinehart JS, Ruddock VE, Schiff I**, Treatment of premenstrual syndrome with alprazolam: results of a double-blind, placebo-controlled, randomized crossover clinical trial, *Obstet Gynecol* 70:37, 1987.
69. **Rapkin AJ, Morgan M, Goldman L, Brann DW, Simone D, Mahesh VB**, Progesterone metabolite allopregnanolone in women with premenstrual syndrome, *Obstet Gynecol* 90:709, 1997.
70. **Rapkin AJ, Edelmuth E, Chang LC, Reading AE, McGuire MT, Su TP**, Whole-blood serotonin in premenstrual syndrome, *Obstet Gynecol* 70:533, 1987.
71. **Taylor DL, Mathew RJ, Ho BT, Weinman ML**, Serotonin levels and platelet uptake during premenstrual tension, *Neuropsychobiology* 12:16, 1984.
72. **Ashby CR Jr, Carr LA, Cook CL, Steptoe MM, Franks DD**, Alteration of platelet serotonergic mechanisms and monoamine oxidase activity in premenstrual syndrome, *Biol Psychiatry* 24:225, 1988.
73. **Steege JF, Stout AL, Knight DL, Nemeroff CB**, Reduced platelet tritium-labeled imipramine binding sites in women with premenstrual syndrome, *Am J Obstet Gynecol* 167:168, 1992.
74. **Rojansky N, Halbreich U, Zander K, Barkai A, Goldstein S**, Imipramine receptor binding and serotonin uptake in platelets of women with premenstrual changes, *Gynecol Obstet Invest* 31:146, 1991.
75. **Menkes DB, Coates DC, Fawcett JP**, Acute tryptophan depletion aggravates premenstrual syndrome, *J Affect Disord* 32:37, 1994.
76. **Brzezinski AA, Wurtman JJ, Wurtman RJ, Gleason R, Greenfield J, Nader T**, D-Fenfluramine suppresses the increased calorie and carbohydrate intakes and improves the mood of women with premenstrual depression, *Obstet Gynecol* 76:296, 1990.
77. **Roca CA, Schmidt PJ, Smith MJ, Danaceau MA, Murphy DL, Rubinow DR**, Effects of metergoline on symptoms in women with premenstrual dysphoric disorder, *Am J Psychiatry* 159:1876, 2002.
78. **Korzekwa MI, Lamont JA, Steiner M**, Late luteal phase dysphoric disorder and the thyroid axis revisited, *J*

Clin Endocrinol Metab 81:2280, 1996.

79. **Schmidt PJ, Grover GN, Roy-Byrne PP, Rubinow DR**, Thyroid function in women with premenstrual syndrome, *J Clin Endocrinol Metab* 76:671, 1993.
80. **Kendler KS, Karkowski LM, Corey LA, Neale MC**, Longitudinal population-based twin study of retrospectively reported premenstrual symptoms and lifetime major depression, *Am J Psychiatry* 155:1234, 1998.
81. **Treloar SA, Heath AC, Martin NG**, Genetic and environmental influences on premenstrual symptoms in an Australian twin sample, *Psychol Med* 32(1):25, 2002.
82. **Freeman EW, Sondheimer SJ, Rickels K**, Effects of medical history factors on symptom severity in women meeting criteria for premenstrual syndrome, *Obstet Gynecol* 72:236, 1988.
83. **Wilson CA, Turner CW, Keye WR**, Firstborn adolescent daughters and mothers with and without premenstrual syndrome: a comparison, *J Adolesc Health* 12:130, 1991.
84. **Fontana AM, Palfai TG**, Psychosocial factors in premenstrual dysphoria: stressors, appraisal, and coping processes, *J Psychosom Res* 38:557, 1994.
85. **Beck LE, Gevirtz R, Mortola JF**, The predictive role of psychosocial stress on symptom severity in premenstrual syndrome, *Psychosom Med* 52:536, 1990.
86. **Gallant SJ, Popiel DA, Hoffman DM, Chakraborty PK, Hamilton JA**, Using daily ratings to confirm premenstrual syndrome/late luteal phase dysphoric disorder. Part I. Effects of demand characteristics and expectations, *Psychosom Med* 54:149, 1992.
87. **Tobin MB, Schmidt PJ, Rubinow DR**, Reported alcohol use in women with premenstrual syndrome, *Am J Psychiatry* 151:1503, 1994.
88. **McLeod DR, Foster GV, Hoehn-Saric R, Svikis DS, Hipsley PA**, Family history of alcoholism in women with generalized anxiety disorder who have premenstrual syndrome: patient reports of premenstrual alcohol consumption and symptoms of anxiety, *Alcohol Clin Exp Res* 18:664, 1994.
89. **Chuong CJ, Dawson EB, Smith ER**, Vitamin A levels in premenstrual syndrome, *Fertil Steril* 54:643, 1990.
90. **Chuong CJ, Dawson EB, Smith ER**, Vitamin E levels in premenstrual syndrome, *Am J Obstet Gynecol* 163:1591, 1990.
91. **Kleijnen J, Ter Riet G, Knipschild P**, Vitamin B6 in the treatment of the premenstrual syndrome—a review, *Br J Obstet Gynaecol* 97:847, 1990.
92. **Stewart A**, Vitamin B6 in the treatment of the premenstrual syndrome—review, *Br J Obstet Gynaecol* 98:329, 1991.
93. **Sherwood RA, Rocks BF, Stewart A, Saxton RS**, Magnesium and the premenstrual syndrome, *Ann Clin Biochem* 23(Pt 6):667, 1986.
94. **Rosenstein DL, Elin RJ, Hosseini JM, Grover G, Rubinow DR**, Magnesium measures across the menstrual cycle in premenstrual syndrome, *Biol Psychiatry* 35:557, 1994.
95. **Cerin A, Collins A, Landgren BM, Eneroth P**, Hormonal and biochemical profiles of premenstrual syndrome. Treatment with essential fatty acids, *Acta Obstet Gynecol Scand* 72:337, 1993.
96. **Posaci C, Erten O, Uren A, Acar B**, Plasma copper, zinc and magnesium levels in patients with premenstrual tension syndrome, *Acta Obstet Gynecol Scand* 73:452, 1994.
97. **Saeedian Kia A, Amani R, Cheraghian B**, The association between the risk of premenstrual syndrome and vitamin D, calcium, and magnesium status among university students: a case control study, *Health Promot Perspect* 5(3):225, 2015. doi: 10.15171/hpp.2015.027. eCollection 2015. Erratum in: *Health Promot Perspect* 6(1):54, 2016.
98. **Bertone-Johnson ER, Hankinson SE, Bendich A, Johnson SR, Willett WC, Manson JE**, Calcium and vitamin D intake and risk of incident premenstrual syndrome, *Arch Intern Med* 165(11):1246, 2005.
99. **Bahrami A, Avan A, Sadeghnia HR, Esmaeili H, Tayefi M, Ghasemi F, Nejati Salehkhani F, Arabpour-Dahoue M, Rastgar-Moghadam A, Ferns GA, Bahrami-Taghanaki H, Ghayour-Mobarhan M**, High dose vitamin D supplementation can improve menstrual problems, dysmenorrhea, and premenstrual syndrome in adolescents, *Gynecol Endocrinol* 34(8):659, 2018.
100. **Dimmock PW, Wyatt KM, Jones PW, O'Brien PM**, Efficacy of selective serotonin-reuptake inhibitors in

premenstrual syndrome: a systematic review, *Lancet* 356:1131, 2000.

101. **Wyatt KM, Dimmock PW, O'Brien PM**, Selective serotonin reuptake inhibitors for premenstrual syndrome, *Cochrane Database Syst Rev* (4):CD001396, 2002.
102. **Harrison WM, Endicott J, Nee J**, Treatment of premenstrual dysphoria with alprazolam. A controlled study, *Arch Gen Psychiatry* 47:270, 1990.
103. **Berger CP, Presser B**, Alprazolam in the treatment of two subsamples of patients with late luteal phase dysphoric disorder: a double-blind, placebo-controlled crossover study, *Obstet Gynecol* 84:379, 1994.
104. **Freeman EW, Sondheimer SJ, Rickels K**, Gonadotropin-releasing hormone agonist in the treatment of premenstrual symptoms with and without ongoing dysphoria: a controlled study, *Psychopharmacol Bull* 33:303, 1997.
105. **Yonkers KA, Brown C, Pearlstein TB, Foegh M, Sampson-Landers C, Rapkin A**, Efficacy of a new low-dose oral contraceptive with drospirenone in premenstrual dysphoric disorder, *Obstet Gynecol* 106:492, 2005.
106. **Pearlstein TB, Bachmann GA, Zacur HA, Yonkers KA**, Treatment of premenstrual dysphoric disorder with a new drospirenone-containing oral contraceptive formulation, *Contraception* 72:414, 2005.
107. **Lopez LM, Kaptein A, Helmerhorst FM**, Oral contraceptives containing drospirenone for premenstrual syndrome, *Cochrane Database Syst Rev* (1):CD006586, 2008.
108. **Steege JF, Blumenthal JA**, The effects of aerobic exercise on premenstrual symptoms in middle-aged women: a preliminary study, *J Psychosom Res* 37:127, 1993.
109. **Aganoff JA, Boyle GJ**, Aerobic exercise, mood states and menstrual cycle symptoms, *J Psychosom Res* 38:183, 1994.
110. **Goodale IL, Domar AD, Benson H**, Alleviation of premenstrual syndrome symptoms with the relaxation response, *Obstet Gynecol* 75:649, 1990.
111. **Oleson T, Flocco W**, Randomized controlled study of premenstrual symptoms treated with ear, hand, and foot reflexology, *Obstet Gynecol* 82:906, 1993.
112. **Burnet RB, Radden HS, Easterbrook EG, McKinnon RA**, Premenstrual syndrome and spironolactone, *Aust N Z J Obstet Gynaecol* 31:366, 1991.
113. **Hellberg D, Claesson B, Nilsson S**, Premenstrual tension: a placebo-controlled efficacy study with spironolactone and medroxyprogesterone acetate, *Int J Gynaecol Obstet* 34:243, 1991.
114. **Wang M, Hammarback S, Lindhe BA, Backstrom T**, Treatment of premenstrual syndrome by spironolactone: a double-blind, placebo-controlled study, *Acta Obstet Gynecol Scand* 74:803, 1995.
115. **O'Brien PM, Craven D, Selby C, Symonds EM**, Treatment of premenstrual syndrome by spironolactone, *Br J Obstet Gynaecol* 86:142, 1979.
116. **Hahn PM, Van Vugt DA, Reid RL**, A randomized, placebo-controlled, crossover trial of danazol for the treatment of premenstrual syndrome, *Psychoneuroendocrinology* 20(2):193, 1995.
117. **Freeman E, Rickels K, Sondheimer SJ, Polansky M**, Ineffectiveness of progesterone suppository treatment for premenstrual syndrome, *JAMA* 264:349, 1990.
118. **Wyatt K, Dimmock P, Jones P, Obhrai M, O'Brien S**, Efficacy of progesterone and progestogens in management of premenstrual syndrome: systematic review, *Br Med J* 323:776, 2001.
119. **Magill PJ**, Investigation of the efficacy of progesterone pessaries in the relief of symptoms of premenstrual syndrome. Progesterone Study Group, *Br J Gen Pract* 45:589, 1995.
120. **Vanselow W, Dennerstein L, Greenwood KM, de Lignieres B**, Effect of progesterone and its 5 alpha and 5 beta metabolites on symptoms of premenstrual syndrome according to route of administration, *J Psychosom Obstet Gynaecol* 17:29, 1996.
121. **Ford O, Lethaby A, Mol B, Roberts H**, Progesterone for premenstrual syndrome, *Cochrane Database Syst Rev* (4):CD003415, 2006.
122. **Khoo SK, Munro C, Battistutta D**, Evening primrose oil and treatment of premenstrual syndrome, *Med J Aust* 153:189, 1990.
123. **Collins A, Cerin A, Coleman G, Landgren BM**, Essential fatty acids in the treatment of premenstrual syndrome, *Obstet Gynecol* 81:93, 1993.

124. **Karimi Z, Dehkordi MA, Alipour A, Mohtashami T**, Treatment of premenstrual syndrome: appraising the effectiveness of cognitive behavioral therapy in addition to calcium supplement plus vitamin D, *Psych J* 7(1):41, 2018.
125. **Shehata NA**, Calcium versus oral contraceptive pills containing drospirenone for the treatment of mild to moderate premenstrual syndrome: a double blind randomized placebo controlled trial, *Eur J Obstet Gynecol Reprod Biol* 198: 100, 2016.
126. **Shobeiri F, Araste FE, Ebrahimi R, Jenabi E, Nazari M**, Effect of calcium on premenstrual syndrome: a double-blind randomized clinical trial, *Obstet Gynecol Sci* 60(1):100, 2017.
127. **Whelan AM, Jurgens TM, Naylor H**, Herbs, vitamins and minerals in the treatment of premenstrual syndrome: a systematic review, *Can J Clin Pharmacol* 16(3):e407, 2009.
128. **Cousins N**, *Anatomy of an Illness*, Bantam Books, New York, 1979.
129. **Eisenberg L**, The subjective in medicine, *Perspect Biol Med* 27:48, 1983.
130. **Panay N**, Treatment of premenstrual syndrome: a decision-making algorithm, *Menopause Int* 18(2):90, 2012.
131. **Brown J, O'Brian PM, Marjoribanks J, Wyatt K**, Selective serotonin reuptake inhibitors for premenstrual syndrome, *Cochrane Database Syst Rev* (2):CD001396, 2009.
132. **Stone AB, Pearlstein TB, Brown WA**, Fluoxetine in the treatment of late luteal phase dysphoric disorder, *J Clin Psychiatry* 52:290, 1991.
133. **Wood SH, Mortola JF, Chan YF, Moossazadeh F, Yen SS**, Treatment of premenstrual syndrome with fluoxetine: a double-blind, placebo-controlled, crossover study, *Obstet Gynecol* 80:339, 1992.
134. **Steiner M, Steinberg S, Stewart D, Carter D, Berger C, Reid R, Grover D, Streiner D**, Fluoxetine in the treatment of premenstrual dysphoria. Canadian Fluoxetine/Premenstrual Dysphoria Collaborative Study Group, *N Engl J Med* 332:1529, 1995.
135. **Steiner M, Romano SJ, Babcock S, Dillon J, Shuler C, Berger C, Carter D, Reid R, Stewart D, Steinberg S, Judge R**, The efficacy of fluoxetine in improving physical symptoms associated with premenstrual dysphoric disorder, *Br J Obstet Gynaecol* 108:462, 2001.
136. **Yonkers KA, Halbreich U, Freeman E, Brown C, Endicott J, Frank E, Parry B, Pearlstein T, Severino S, Stout A, Stone A, Harrison W**, Symptomatic improvement of premenstrual dysphoric disorder with sertraline treatment. A randomized controlled trial. Sertraline Premenstrual Dysphoric Collaborative Study Group, *JAMA* 278:983, 1997.
137. **Freeman EW, Rickels K, Sondheimer SJ, Polansky M**, Differential response to antidepressants in women with premenstrual syndrome/premenstrual dysphoric disorder: a randomized controlled trial, *Arch Gen Psychiatry* 56: 932, 1999.
138. **Eriksson E, Hedberg MA, Andersch B, Sundblad C**, The serotonin reuptake inhibitor paroxetine is superior to the noradrenaline reuptake inhibitor maprotiline in the treatment of premenstrual syndrome, *Neuropsychopharmacology* 12:167, 1995.
139. **Wikander I, Sundblad C, Andersch B, Dagnell I, Zylberstein D, Bengtsson F, Eriksson E**, Citalopram in premenstrual dysphoria: is intermittent treatment during luteal phases more effective than continuous medication throughout the menstrual cycle?, *J Clin Psychopharmacol* 18:390, 1998.
140. **Freeman EW, Rickels K, Yonkers KA, Kunz NR, McPherson M, Upton GV**, Venlafaxine in the treatment of premenstrual dysphoric disorder, *Obstet Gynecol* 98:737, 2001.
141. **Sundblad C, Modigh K, Andersch B, Eriksson E**, Clomipramine effectively reduces premenstrual irritability and dysphoria: a placebo-controlled trial, *Acta Psychiatr Scand* 85:39, 1992.
142. **Sundblad C, Hedberg MA, Eriksson E**, Clomipramine administered during the luteal phase reduces the symptoms of premenstrual syndrome: a placebo-controlled trial, *Neuropsychopharmacology* 9:133, 1993.
143. **Freeman EW, Rickels K, Sondheimer SJ, Denis A, Pfeifer S, Weil S**, Nefazodone in the treatment of premenstrual syndrome: a preliminary study, *J Clin Psychopharmacol* 14:180, 1994.
144. **Steiner M, Korzekwa M, Lamont J, Wilkins A**, Intermittent fluoxetine dosing in the treatment of women with premenstrual dysphoria, *Psychopharmacol Bull* 33:771, 1997.
145. **Halbreich U, Bergeron R, Yonkers KA, Freeman E, Stout AL, Cohen L**, Efficacy of intermittent, luteal phase sertraline treatment of premenstrual dysphoric disorder, *Obstet Gynecol* 100:1219, 2002.

146. **Yonkers KA, Holthausen GA, Poschman K, Howell HB**, Symptom-onset treatment for women with premenstrual dysphoric disorder, *J Clin Psychopharmacol* 26:198, 2006.
147. **Landen M, Erlandsson H, Bengtsson F, Andersch B, Eriksson E**, Short onset of action of a serotonin reuptake inhibitor when used to reduce premenstrual irritability, *Neuropsychopharmacology* 34:585, 2009.
148. **Cohen LS, Miner C, Brown EW, Freeman E, Halbreich U, Sundell K, McCray S**, Premenstrual daily fluoxetine for premenstrual dysphoric disorder: a placebo-controlled, clinical trial using computerized diaries, *Obstet Gynecol* 100: 435, 2002.
149. **Miner C, Brown E, McCray S, Gonzales J, Wohlreich M**, Weekly luteal-phase dosing with enteric-coated fluoxetine 90 mg in premenstrual dysphoric disorder: a randomized, double-blind, placebo-controlled clinical trial, *Clin Ther* 24:417, 2002.
150. **Shah NR, Jones JB, Aperi J, Shemtov R, Karne A, Borenstein J**, Selective serotonin reuptake inhibitors for premenstrual syndrome and premenstrual dysphoric disorder: a meta-analysis, *Obstet Gynecol* 111:1175, 2008.
151. **Muse KN, Cetel NS, Futterman LA, Yen SC**, The premenstrual syndrome. Effects of “medical ovariectomy”, *N Engl J Med* 311:1345, 1984.
152. **West CP, Hillier H**, Ovarian suppression with the gonadotrophin-releasing hormone agonist goserelin (Zoladex) in management of the premenstrual tension syndrome, *Hum Reprod* 9:1058, 1994.
153. **Mezrow G, Shoupe D, Spicer D, Lobo R, Leung B, Pike M**, Depot leuprolide acetate with estrogen and progestin add-back for long-term treatment of premenstrual syndrome, *Fertil Steril* 62:932, 1994.
154. **Wyatt KM, Dimmock PW, Ismail KM, Jones PW, O’Brien PM**, The effectiveness of GnRH $\alpha$  with and without ‘add-back’ therapy in treating premenstrual syndrome: a meta analysis, *Br J Obstet Gynaecol* 111:585, 2004.
155. **Mitwally MF, Gotlieb L, Casper RF**, Prevention of bone loss and hypoestrogenic symptoms by estrogen and interrupted progestogen add-back in long-term GnRH-agonist down-regulated patients with endometriosis and premenstrual syndrome, *Menopause* 9:236, 2002.
156. **Graham CA, Sherwin BB**, A prospective treatment study of premenstrual symptoms using a triphasic oral contraceptive, *J Psychosom Res* 36:257, 1992.
157. **Freeman EW, Kroll R, Rapkin A, Pearlstein T, Brown C, Parsey K, Zhang P, Patel H, Foegh M**, Evaluation of a unique oral contraceptive in the treatment of premenstrual dysphoric disorder, *J Womens Health Gend Based Med* 10:561, 2001.
158. **Lopez LM, Kaptein AA, Helmerhorst FM**, Oral contraceptives containing drospirenone for premenstrual syndrome, *Cochrane Database Syst Rev* (2):CD006586, 2009.
159. **Merki-Feld GS, Hund M**, Clinical experience with the combined contraceptive vaginal ring in Switzerland, including a subgroup analysis of previous hormonal contraceptive use, *Eur J Contracept Reprod Health Care* 15(6):413, 2010.
160. **Dante G, Facchinetti F**, Herbal treatments for alleviating premenstrual symptoms: a systematic review, *J Psychosom Obstet Gynaecol* 32(1):42, 2011.
161. **Canning S, Waterman M, Orsi N, Ayres J, Simpson N, Dye L**, The efficacy of *Hypericum perforatum* (St John’s wort) for the treatment of premenstrual syndrome: a randomized, double-blind, placebo-controlled trial, *CNS Drugs* 24(3):207, 2010.
162. **Sampson GA**, Premenstrual syndrome: a double-blind controlled trial of progesterone and placebo, *Br J Psychiatry* 135:209, 1979.
163. **Van der Meer YG, Benedek-Jaszmann LJ, Van Loenen AC**, Effects of high-dose progesterone on the premenstrual syndrome: a double-blind cross-over trial, *J Psychosom Obstet Gynecol* 2:220, 1983.
164. **Andersch B, Hahn L**, Progesterone treatment of premenstrual tension—a double blind study, *J Psychosom Res* 29:489, 1985.
165. **Richter MA, Haltvick R, Shapiro SS**, Progesterone treatment of premenstrual syndrome, *Curr Ther Res* 36:840, 1984.
166. **Maddocks S, Hahn P, Moller F, Reid RL**, A double-blind placebo-controlled trial of progesterone vaginal suppositories in the treatment of premenstrual syndrome, *Am J Obstet Gynecol* 154:573, 1986.

167. **Freeman EW, Richels K, Sondheimer SJ, Polansky M**, A double-blind trial of oral progesterone, alprazolam, and placebo in treatment of severe premenstrual syndrome, *JAMA* 274:51, 1995.
168. **Ford O, Lethaby A, Roberts H, Mol BW**, Progesterone for premenstrual syndrome, *Cochrane Database Syst Rev* (2):CD003415, 2009.
169. **Jenkin G**, Review: the mechanism of action of danazol, a novel steroid derivative, *Aust N Z J Obstet Gynaecol* 20(2):113, 1980.
170. **Cronje WH, Vashisht A, Studd JW**, Hysterectomy and bilateral oophorectomy for severe premenstrual syndrome, *Hum Reprod* 19(9):2152, 2004.
171. **Reid RL**, When should surgical treatment be considered for premenstrual dysphoric disorder? *Menopause Int* 18(2):77, 2012.
172. Dawood MY, ed. *Dysmenorrhea*, Williams & Wilkins, Baltimore, 1981.
173. **Hertweck SP**, Dysfunctional uterine bleeding, *Obstet Gynecol Clin North Am* 19:129, 1992.
174. **Campbell MA, McGrath PJ**, Use of medication by adolescents for the management of menstrual discomfort, *Arch Pediatr Adolesc Med* 151:905, 1997.
175. **Wilson CA, Keye WR Jr**, A survey of adolescent dysmenorrhea and premenstrual symptom frequency. A model program for prevention, detection, and treatment, *J Adolesc Health Care* 10:317, 1989.
176. **Johnson J**, Level of knowledge among adolescent girls regarding effective treatment for dysmenorrhea, *J Adolesc Health Care* 9:398, 1988.
177. **Klein JR, Litt IF**, Epidemiology of adolescent dysmenorrhea, *Pediatrics* 68:661, 1981.
178. **Andersch B, Milsom I**, An epidemiologic study of young women with dysmenorrhea, *Am J Obstet Gynecol* 144:655, 1982.
179. **Sundell G, Milsom I, Andersch B**, Factors influencing the prevalence and severity of dysmenorrhea in young women, *Br J Obstet Gynaecol* 97:588, 1990.
180. **Burnett MA, Antao V, Black A, Feldman K, Grenville A, Lea R, Lefebvre G, Pinsonneault O, Robert M**, Prevalence of primary dysmenorrhea in Canada, *J Obstet Gynaecol Can* 27:765, 2005.
181. **Harlow SD, Park M**, A longitudinal study of risk factors for the occurrence, duration and severity of menstrual cramps in a cohort of college women, *Br J Obstet Gynaecol* 103:1134, 1996.
182. **Latthe P, Mignini L, Gray R, Hills R, Khan K**, Factors predisposing women to chronic pelvic pain: systematic review, *Br Med J* 332:749, 2006.
183. **Altunyurt S, Gol M, Sezer O, Demir N**, Primary dysmenorrhea and uterine blood flow: a color Doppler study, *J Reprod Med* 50:251, 2005.
184. **Ylikorkala O, Dawood MY**, New concepts in dysmenorrhea, *Am J Obstet Gynecol* 130:833, 1978.
185. **Chan WY, Dawood MY, Fuchs F**, Relief of dysmenorrhea with the prostaglandin synthetase inhibitor ibuprofen: effect on prostaglandin levels in menstrual fluid, *Am J Obstet Gynecol* 135:102, 1979.
186. **Smith RP**, The dynamics of nonsteroidal anti-inflammatory therapy for primary dysmenorrhea, *Obstet Gynecol* 70:785, 1987.
187. **Dawood MY**, Primary dysmenorrhea: advances in pathogenesis and management, *Obstet Gynecol* 108:428, 2006.
188. **Barbieri RL, Callery M, Perez SE**, Directionality of menstrual flow: cervical os diameter as a determinant of retrograde menstruation, *Fertil Steril* 57:727, 1992.
189. **Propst AM, Storti K, Barbieri RL**, Lateral cervical displacement is associated with endometriosis, *Fertil Steril* 70:568, 1998.
190. **Woodworth SH, Singh M, Yussman MA, Sanfilippo JS, Cook CL, Lincoln SR**, A prospective study on the association between red hair color and endometriosis in infertile patients, *Fertil Steril* 64:651, 1995.
191. **Cramer DW, Hornstein MD, Ng WG, Barbieri RL**, Endometriosis associated with the N314D mutation of galactose-1-phosphate uridyl transferase (GALT), *Mol Hum Reprod* 2:149, 1996.
192. **Hornstein MD, Thomas PP, Sober AJ, Wyshak G, Albright NL, Frisch RE**, Association between endometriosis, dysplastic naevi and history of melanoma in women of reproductive age, *Hum Reprod* 12:143, 1997.
193. **Meredith SM, Sanchez-Ramos L, Kaunitz AM**, Diagnostic accuracy of transvaginal sonography for the

diagnosis of adenomyosis: systematic review and metaanalysis, *Am J Obstet Gynecol* 201:107 e1, 2009.

194. **Barbieri RL, Niloff JM, Bast RC Jr, Scaetzel E, Kistner RW, Knapp RC**, Elevated serum concentrations of CA-125 in patients with advanced endometriosis, *Fertil Steril* 45:630, 1986.
195. **Hornstein MD, Thomas PP, Gleason RE, Barbieri RL**, Menstrual cyclicity of CA-125 in patients with endometriosis, *Fertil Steril* 58:279, 1992.
196. **Akin MD, Weingand KW, Hengehold DA, Goodale MB, Hinkle RT, Smith RP**, Continuous low-level topical heat in the treatment of dysmenorrhea, *Obstet Gynecol* 97:343, 2001.
197. **Akin M, Price W, Rodriguez G Jr, Erasala G, Hurley G, Smith RP**, Continuous, low-level, topical heat wrap therapy as compared to acetaminophen for primary dysmenorrhea, *J Reprod Med* 49:739, 2004.
198. **Barnard ND, Scialli AR, Hurlock D, Bertron P**, Diet and sex-hormone binding globulin, dysmenorrhea, and premenstrual symptoms, *Obstet Gynecol* 95:245, 2000.
199. **Ziaei S, Faghihzadeh S, Sohravand F, Lamyian M, Emamgholy T**, A randomised placebo-controlled trial to determine the effect of vitamin E in treatment of primary dysmenorrhoea, *Br J Obstet Gynaecol* 108:1181, 2001.
200. **Ziaei S, Zakeri M, Kazemnejad A**, A randomised controlled trial of vitamin E in the treatment of primary dysmenorrhoea, *Br J Obstet Gynaecol* 112:466, 2005.
201. **Proctor ML, Murphy PA**, Herbal and dietary therapies for primary and secondary dysmenorrhoea, *Cochrane Database Syst Rev* (3):CD002124, 2001.
202. **Zhu X, Proctor M, Bensoussan A, Smith CA, Wu E**, Chinese herbal medicine for primary dysmenorrhoea, *Cochrane Database Syst Rev* (4):CD005288, 2007.
203. **Golomb LM, Solidum AA, Warren MP**, Primary dysmenorrhea and physical activity, *Med Sci Sports Exerc* 30:906, 1998.
204. **Metheny WP, Smith RP**, The relationship among exercise, stress, and primary dysmenorrhea, *J Behav Med* 12:569, 1989.
205. **Proctor ML, Murphy PA, Pattison HM, Suckling J, Farquhar CM**, Behavioural interventions for primary and secondary dysmenorrhoea, *Cochrane Database Syst Rev* (3):CD002248, 2007.
206. **Proctor M, Farquhar C**, Dysmenorrhoea, *Clin Evid* (9):1994, 2003.
207. **Zhang WY, Li Wan Po A**, Efficacy of minor analgesics in primary dysmenorrhoea: a systematic review, *Br J Obstet Gynaecol* 105:780, 1998.
208. **French L**, Dysmenorrhea, *Am Fam Physician* 71:285, 2005.
209. **Alvin PE, Litt IF**, Current status of the etiology and management of dysmenorrhea in adolescence, *Pediatrics* 70:516, 1982.
210. **Chan WY, Dawood MY, Fuchs F**, Prostaglandins in primary dysmenorrhea. Comparison of prophylactic and nonprophylactic treatment with ibuprofen and use of oral contraceptives, *Am J Med* 70:535, 1981.
211. **Henzl MR, Buttram V, Segre EJ, Bessler S**, The treatment of dysmenorrhea with naproxen sodium: a report on two independent double-blind trials, *Am J Obstet Gynecol* 127:818, 1977.
212. **Larkin RM, Van Orden DE, Poulson AM, Scott JR**, Dysmenorrhea: treatment with an antiprostaglandin, *Obstet Gynecol* 54:456, 1979.
213. **Smith RP**, Cyclic pelvic pain and dysmenorrhea, *Obstet Gynecol Clin North Am* 20:753, 1993.
214. **Owen PR**, Prostaglandin synthetase inhibitors in the treatment of primary dysmenorrhea. Outcome trials reviewed, *Am J Obstet Gynecol* 148:96, 1984.
215. **Budoff PW**, Use of mefenamic acid in the treatment of primary dysmenorrhea, *JAMA* 241:2713, 1979.
216. **Athanasίου S, Bourne TH, Khalid A, Okokon EV, Crayford TJ, Hagstrom HG, Campbell S, Collins WP**, Effects of indomethacin on follicular structure, vascularity, and function over the periovulatory period in women, *Fertil Steril* 65:556, 1996.
217. **Uhler ML, Hsu JW, Fisher SG, Zinaman MJ**, The effect of nonsteroidal anti-inflammatory drugs on ovulation: a prospective, randomized clinical trial, *Fertil Steril* 76:957, 2001.
218. **Pall M, Friden BE, Brannstrom M**, Induction of delayed follicular rupture in the human by the selective COX-2 inhibitor rofecoxib: a randomized double-blind study, *Hum Reprod* 16:1323, 2001.
219. **Norman RJ, Wu R**, The potential danger of COX-2 inhibitors, *Fertil Steril* 81:493, 2004.

220. **Davis AR, Westhoff C, O'Connell K, Gallagher N**, Oral contraceptives for dysmenorrhea in adolescent girls: a randomized trial, *Obstet Gynecol* 106:97, 2005.
221. **Endrikat J, Jaques MA, Mayerhofer M, Pelissier C, Muller U, Dusterberg B**, A twelve-month comparative clinical investigation of two low-dose oral contraceptives containing 20 micrograms ethinylestradiol/75 micrograms gestodene and 20 micrograms ethinylestradiol/150 micrograms desogestrel, with respect to efficacy, cycle control and tolerance, *Contraception* 52:229, 1995.
222. **Proctor ML, Roberts H, Farquhar CM**, Combined oral contraceptive pill (OCP) as treatment for primary dysmenorrhoea, *Cochrane Database Syst Rev* (4):CD002120, 2001.
223. **Hendrix SL, Alexander NJ**, Primary dysmenorrhea treatment with a desogestrel-containing low-dose oral contraceptive, *Contraception* 66:393, 2002.
224. **Anderson FD, Hait H**, A multicenter, randomized study of an extended cycle oral contraceptive, *Contraception* 68:89, 2003.
225. **Anderson FD, Gibbons W, Portman D**, Safety and efficacy of an extended-regimen oral contraceptive utilizing continuous low-dose ethinyl estradiol, *Contraception* 73:229, 2006.
226. **Edelman AB, Gallo MF, Jensen JT, Nichols MD, Schulz KF, Grimes DA**, Continuous or extended cycle vs. cyclic use of combined oral contraceptives for contraception, *Cochrane Database Syst Rev* (3):CD004695, 2005.
227. **Roumen FJ**, The contraceptive vaginal ring compared with the combined oral contraceptive pill: a comprehensive review of randomized controlled trials, *Contraception* 75:420, 2007.
228. **Harel Z, Biro FM, Kollar LM**, Depo-Provera in adolescents: effects of early second injection or prior oral contraception, *J Adolesc Health* 16:379, 1995.
229. **Varma R, Sinha D, Gupta JK**, Non-contraceptive uses of levonorgestrel-releasing hormone system (LNG-IUS)—a systematic enquiry and overview, *Eur J Obstet Gynecol Reprod Biol* 125:9, 2006.
230. **Heikinheimo O, Gemzell-Danielsson K**, Emerging indications for the levonorgestrel-releasing intrauterine system (LNG-IUS), *Acta Obstet Gynecol Scand* 91(1):3, 2012. doi: 10.1111/j.1600-0412.2011.01303.x.
231. **Yucel N, Baskent E, Karamustafaoglu Balci B, Goynumer G**, The levonorgestrel-releasing intrauterine system is associated with a reduction in dysmenorrhoea and dyspareunia, a decrease in CA 125 levels, and an increase in quality of life in women with suspected endometriosis, *Aust N Z J Obstet Gynaecol* 58(5):560, 2018.
232. **Lindh I, Milsom I**, The influence of intrauterine contraception on the prevalence and severity of dysmenorrhea: a longitudinal population study, *Hum Reprod* 28(7):1953, 2013.
233. **Croxatto HB**, Clinical profile of Implanon: a single-rod etonogestrel contraceptive implant, *Eur J Contracept Reprod Health Care* 5 (Suppl 2):21, 2000.
234. **Ling FW**, Randomized controlled trial of depot leuprolide in patients with chronic pelvic pain and clinically suspected endometriosis. Pelvic Pain Study Group, *Obstet Gynecol* 93:51, 1999.
235. **Nattero G**, Menstrual headache, *Adv Neurol* 33:215, 1982.
236. **Olesen J**, The International Classification of Headache Disorders, 2nd edition: application to practice, *Funct Neurol* 20:61, 2005.
237. **Charles A**, Advances in the basic and clinical science of migraine, *Ann Neurol* 65:491, 2009.
238. **Arbab MA, Wiklund L, Svendgaard NA**, Origin and distribution of cerebral vascular innervation from superior cervical, trigeminal and spinal ganglia investigated with retrograde and anterograde WGA-HRP tracing in the rat, *Neuroscience* 19:695, 1986.
239. **Goadsby PJ, Edvinsson L, Ekman R**, Release of vasoactive peptides in the extracerebral circulation of humans and the cat during activation of the trigeminovascular system, *Ann Neurol* 23:193, 1988.
240. **Burstein R**, Deconstructing migraine headache into peripheral and central sensitization, *Pain* 89:107, 2001.
241. **Strassman AM, Raymond SA, Burstein R**, Sensitization of meningeal sensory neurons and the origin of headaches, *Nature* 384:560, 1996.
242. **Kaube H, Katsarava Z, Przywara S, Drepper J, Ellrich J, Diener HC**, Acute migraine headache: possible sensitization of neurons in the spinal trigeminal nucleus?, *Neurology* 58:1234, 2002.
243. **Takano T, Nedergaard M**, Deciphering migraine, *J Clin Invest* 119:16, 2009.



244. **Waters WE, O'Connor PJ**, Epidemiology of headache and migraine in women, *J Neurol Neurosurg Psychiatry* 34:148, 1971.
245. **Sheftell FD, Silberstein SD, Rapoport AM, Rossum RW**, Migraine and women: diagnosis, pathophysiology, and treatment, *J Women's Health* 1: 5, 1992.
246. **Neri I, Granella F, Nappi R, Manzoni GC, Facchinetti F, Genazzani AR**, Characteristics of headache at menopause: a clinico-epidemiologic study, *Maturitas* 17:31, 1993.
247. **MacGregor EA**, Menstruation, sex hormones, and migraine, *Neurol Clin* 15:125, 1997.
248. **Martin VT, Behbehani M**, Ovarian hormones and migraine headache: understanding mechanisms and pathogenesis—part 2, *Headache* 46:365, 2006.
249. **Johannes CB, Linet MS, Stewart WF, Celentano DD, Lipton RB, Szklo M**, Relationship of headache to phase of the menstrual cycle among young women: a daily diary study, *Neurology* 45:1076, 1995.
250. **MacGregor EA, Hackshaw A**, Prevalence of migraine on each day of the natural menstrual cycle, *Neurology* 63:351, 2004.
251. **Couturier EG, Bomhof MA, Neven AK, van Duijn NP**, Menstrual migraine in a representative Dutch population sample: prevalence, disability and treatment, *Cephalalgia* 23:302, 2003.
252. **Brandes JL**, The influence of estrogen on migraine: a systematic review, *JAMA* 295:1824, 2006.
253. **Somerville BW**, Estrogen-withdrawal migraine. I. Duration of exposure required and attempted prophylaxis by premenstrual estrogen administration, *Neurology* 25:239, 1975.
254. **Somerville BW**, Estrogen-withdrawal migraine. II. Attempted prophylaxis by continuous estradiol administration, *Neurology* 25:245, 1975.
255. **Martin VT, Behbehani M**, Ovarian hormones and migraine headache: understanding mechanisms and pathogenesis—part I, *Headache* 46:3, 2006.
256. **The International Classification of Headache Disorders: 2nd edition**, *Cephalalgia* 24(Suppl 1):9, 2004.
257. **Jensen R**, Peripheral and central mechanisms in tension-type headache: an update, *Cephalalgia* 23(Suppl 1):49, 2003.
258. **Zagami AS**, Pathophysiology of migraine and tension-type headache, *Curr Opin Neurol* 7:272, 1994.
259. **Bendtsen L**, Central sensitization in tension-type headache—possible pathophysiological mechanisms, *Cephalalgia* 20:486, 2000.
260. **Ashina M**, Neurobiology of chronic tension-type headache, *Cephalalgia* 24:161, 2004.
261. **Thomsen LL, Olesen J**, Nitric oxide in primary headaches, *Curr Opin Neurol* 14:315, 2001.
262. **Russell MB, Iselius L, Ostergaard S, Olesen J**, Inheritance of chronic tension-type headache investigated by complex segregation analysis, *Hum Genet* 102:138, 1998.
263. **Russell MB, Ostergaard S, Bendtsen L, Olesen J**, Familial occurrence of chronic tension-type headache, *Cephalalgia* 19:207, 1999.
264. **Kumar KL, Cooney TG**, Headaches, *Med Clin North Am* 79:261, 1995.
265. **Ashkenazi A, Silberstein S**, Menstrual migraine: a review of hormonal causes, prophylaxis and treatment, *Expert Opin Pharmacother* 8:1605, 2007.
266. **Pringsheim T, Davenport WJ, Dodick D**, Acute treatment and prevention of menstrually related migraine headache: evidence-based review, *Neurology* 70:1555, 2008.
267. **Goldstein J, Keywood C**, Frovatriptan for the acute treatment of migraine: a dose-finding study, *Headache* 42:41, 2002.
268. **Calhoun A, Ford S**, Elimination of menstrual-related migraine beneficially impacts chronification and medication overuse, *Headache* 48:1186, 2008.
269. **Calhoun AH**, A novel specific prophylaxis for menstrual-associated migraine, *South Med J* 97:819, 2004.
270. **World Health Organization**, Ischaemic stroke and combined oral contraceptives: results of an international, multicentre, case-control study. WHO Collaborative Study of Cardiovascular Disease and Steroid Hormone Contraception, *Lancet* 348:498, 1996.
271. **Chan WS, Ray J, Wai EK, Ginsburg S, Hannah ME, Corey PN, Ginsberg JS**, Risk of stroke in women exposed to low-dose oral contraceptives: a critical evaluation of the evidence, *Arch Intern Med* 164:741, 2004.
272. **Etminan M, Takkouche B, Isorna FC, Samii A**, Risk of ischaemic stroke in people with migraine:

systematic review and meta-analysis of observational studies, *Br Med J* 330:63, 2005.

273. **Petitti DB, Sidney S, Bernstein A, Wolf S, Quesenberry C, Ziel HK**, Stroke in users of low-dose oral contraceptives, *N Engl J Med* 335:8, 1996.
274. **Schwartz SM, Petitti DB, Siscovick DS, Longstreth WT, Jr., Sidney S, Raghunathan TE, Quesenberry CP Jr, Kelaghan J**, Stroke and use of low-dose oral contraceptives in young women: a pooled analysis of two US studies, *Stroke* 29:2277, 1998.
275. **Dennerstein L, Morse C, Burrows G, Oats J, Brown J, Smith M**, Menstrual migraine: a double-blind trial of percutaneous estradiol, *Gynecol Endocrinol* 2:113, 1988.
276. **MacGregor EA, Frith A, Ellis J, Aspinall L, Hackshaw A**, Prevention of menstrual attacks of migraine: a double-blind placebo-controlled crossover study, *Neurology* 67:2159, 2006.
277. **Murray SC, Muse KN**, Effective treatment of severe menstrual migraine headaches with gonadotropin-releasing hormone agonist and “add-back” therapy, *Fertil Steril* 67:390, 1997.
278. **Martin V, Wernke S, Mandell K, Zoma W, Bean J, Pinney S, Liu J, Ramadan N, Rebar R**, Medical oophorectomy with and without estrogen add-back therapy in the prevention of migraine headache, *Headache* 43:309, 2003.
279. **Mattsson P**, Hormonal factors in migraine: a population-based study of women aged 40 to 74 years, *Headache* 43:27, 2003.
280. **Misakian AL, Langer RD, Bensenor IM, Cook NR, Manson JE, Buring JE, Rexrode KM**, Postmenopausal hormone therapy and migraine headache, *J Womens Health (Larchmt)* 12:1027, 2003.
281. **Sances G, Martignoni E, Fioroni L, Blandini F, Facchinetti F, Nappi G**, Naproxen sodium in menstrual migraine prophylaxis: a double-blind placebo controlled study, *Headache* 30:705, 1990.
282. **Newman LC, Lipton RB, Lay CL, Solomon S**, A pilot study of oral sumatriptan as intermittent prophylaxis of menstruation-related migraine, *Neurology* 51:307, 1998.
283. **Newman L, Mannix LK, Landy S, Silberstein S, Lipton RB, Putnam DG, Watson C, Jobsis M, Batenhorst A, O’Quinn S**, Naratriptan as short-term prophylaxis of menstrually associated migraine: a randomized, double-blind, placebo-controlled study, *Headache* 41:248, 2001.
284. **Goldstein J**, Frovatriptan: a review, *Expert Opin Pharmacother* 4:83, 2003.
285. **Tepper SJ**, History and review of anti-Calcitonin Gene-Related Peptide (CGRP) therapies: from translational research to treatment, *Headache* 58(Suppl 3):238, 2018.
286. **Newmark ME, Penry JK**, Catamenial epilepsy: a review, *Epilepsia* 21:281, 1980.
287. **Reddy DS**, Role of neurosteroids in catamenial epilepsy, *Epilepsy Res* 62:99, 2004.
288. **Reddy DS**, The role of neurosteroids in the pathophysiology and treatment of catamenial epilepsy, *Epilepsy Res* 85:1, 2009.
289. **Herzog AG, Harden CL, Liporace J, Pennell P, Schomer DL, Sperling M, Fowler K, Nikolov B, Shuman S, Newman M**, Frequency of catamenial seizure exacerbation in women with localization-related epilepsy, *Ann Neurol* 56:431, 2004.
290. **Bazan AC, Montenegro MA, Cendes F, Min LL, Guerreiro CA**, Menstrual cycle worsening of epileptic seizures in women with symptomatic focal epilepsy, *Arq Neuropsiquiatr* 63:751, 2005.
291. **El-Khayat HA, Soliman NA, Tomoum HY, Omran MA, El-Wakad AS, Shatla RH**, Reproductive hormonal changes and catamenial pattern in adolescent females with epilepsy, *Epilepsia* 49:1619, 2008.
292. **Kaplan PW, Norwitz ER, Ben-Menachem E, Pennell PB, Druzin M, Robinson JN, Gordon JC**, Obstetric risks for women with epilepsy during pregnancy, *Epilepsy Behav* 11:283, 2007.
293. **Pennell PB**, Antiepileptic drugs during pregnancy: what is known and which AEDs seem to be safest?, *Epilepsia* 49(Suppl 9):43, 2008.
294. **Reddy DS, Rogawski MA**, Neurosteroid replacement therapy for catamenial epilepsy, *Neurotherapeutics* 6:392, 2009.
295. **Foldvary-Schaefer N, Falcone T**, Catamenial epilepsy: pathophysiology, diagnosis, and management, *Neurology* 61:S2, 2003.
296. **Reddy DS**, Neuroendocrine aspects of catamenial epilepsy, *Horm Behav* 63(2):254, 2013.
297. **Scharfman HE, Mercurio TC, Goodman JH, Wilson MA, MacLusky NJ**, Hippocampal excitability

- increases during the estrous cycle in the rat: a potential role for brain-derived neurotrophic factor, *J Neurosci* 23:11641, 2003.
298. **Tuveri A, Paoletti AM, Orru M, Melis GB, Marotto MF, Zedda P, Marrosu F, Sogliano C, Marra C, Biggio G, Concas A**, Reduced serum level of THDOC, an anticonvulsant steroid, in women with perimenstrual catamenial epilepsy, *Epilepsia* 49:1221, 2008.
  299. **Stoffel-Wagner B**, Neurosteroid biosynthesis in the human brain and its clinical implications, *Ann N Y Acad Sci* 1007:64, 2003.
  300. **Lambert JJ, Belelli D, Peden DR, Vardy AW, Peters JA**, Neurosteroid modulation of GABAA receptors, *Prog Neurobiol* 71:67, 2003.
  301. **Nijima S, Wallace SJ**, Effects of puberty on seizure frequency, *Dev Med Child Neurol* 31:174, 1989.
  302. **Abbasi F, Krumholz A, Kittner SJ, Langenberg P**, Effects of menopause on seizures in women with epilepsy, *Epilepsia* 40:205, 1999.
  303. **Harden CL, Pulver MC, Ravdin L, Jacobs AR**, The effect of menopause and perimenopause on the course of epilepsy, *Epilepsia* 40:1402, 1999.
  304. **Roste LS, Tauboll E, Svalheim S, Gjerstad L**, Does menopause affect the epilepsy?, *Seizure* 17:172, 2008.
  305. **Harden CL, Leppik I**, Optimizing therapy of seizures in women who use oral contraceptives, *Neurology* 67:S56, 2006.
  306. **Harden CL**, Hormone replacement therapy: will it affect seizure control and AED levels?, *Seizure* 17:176, 2008.
  307. **Bilo L, Meo R**, Epilepsy and polycystic ovary syndrome: where is the link?, *Neurol Sci* 27:221, 2006.
  308. **Herzog AG**, Disorders of reproduction in patients with epilepsy: primary neurological mechanisms, *Seizure* 17:101, 2008.
  309. **Rogawski MA, Loscher W**, The neurobiology of antiepileptic drugs, *Nat Rev Neurosci* 5:553, 2004.
  310. **Isojarvi JI, Tauboll E, Herzog AG**, Effect of antiepileptic drugs on reproductive endocrine function in individuals with epilepsy, *CNS Drugs* 19:207, 2005.
  311. **Betts T, Yarrow H, Dutton N, Greenhill L, Rolfe T**, A study of anticonvulsant medication on ovarian function in a group of women with epilepsy who have only ever taken one anticonvulsant compared with a group of women without epilepsy, *Seizure* 12:323, 2003.
  312. **Veliskova J**, Estrogens and epilepsy: why are we so excited?, *Neuroscientist* 13:77, 2007.
  313. **Mattson RH, Cramer JA, Darney PD, Naftolin F**, Use of oral contraceptives by women with epilepsy, *JAMA* 256:238, 1986.
  314. **Vessey M, Painter R, Yeates D**, Oral contraception and epilepsy: findings in a large cohort study, *Contraception* 66:77, 2002.
  315. **Crawford P**, Best practice guidelines for the management of women with epilepsy, *Epilepsia* 46(Suppl 9):117, 2005.
  316. **Klostervskov Jensen P, Saano V, Haring P, Svenstrup B, Menge GP**, Possible interaction between oxcarbazepine and an oral contraceptive, *Epilepsia* 33:1149, 1992.
  317. **Rosenfeld WE, Doose DR, Walker SA, Nayak RK**, Effect of topiramate on the pharmacokinetics of an oral contraceptive containing norethindrone and ethinyl estradiol in patients with epilepsy, *Epilepsia* 38:317, 1997.
  318. **Fattore C, Cipolla G, Gatti G, Limido GL, Sturm Y, Bernasconi C, Perucca E**, Induction of ethinylestradiol and levonorgestrel metabolism by oxcarbazepine in healthy women, *Epilepsia* 40:783, 1999.
  319. **Sidhu J, Job S, Singh S, Philipson R**, The pharmacokinetic and pharmacodynamic consequences of the co-administration of lamotrigine and a combined oral contraceptive in healthy female subjects, *Br J Clin Pharmacol* 61:191, 2006.
  320. **Sabers A, Ohman I, Christensen J, Tomson T**, Oral contraceptives reduce lamotrigine plasma levels, *Neurology* 61:570, 2003.
  321. **Galimberti CA, Mazzucchelli I, Arbasino C, Canevini MP, Fattore C, Perucca E**, Increased apparent oral clearance of valproic acid during intake of combined contraceptive steroids in women with epilepsy, *Epilepsia* 47:1569, 2006.

322. **Montouris G**, Importance of monotherapy in women across the reproductive cycle, *Neurology* 69:S10, 2007.
323. **Wegner I, Edelbroek PM, Bulk S, Lindhout D**, Lamotrigine kinetics within the menstrual cycle, after menopause, and with oral contraceptives, *Neurology* 73:1388, 2009.
324. **Lim LL, Foldvary N, Mascha E, Lee J**, Acetazolamide in women with catamenial epilepsy, *Epilepsia* 42:746, 2001.
325. **Feely M, Gibson J**, Intermittent clobazam for catamenial epilepsy: tolerance avoided, *J Neurol Neurosurg Psychiatry* 47:1279, 1984.
326. **Gilad R, Sadeh M, Rapoport A, Dabby R, Lampl Y**, Lamotrigine and catamenial epilepsy, *Seizure* 17:531, 2008.
327. **McAuley JW, Moore JL, Reeves AL, Flyak J, Monaghan EP, Data J**, A pilot study of the neurosteroid ganaxolone in catamenial epilepsy: clinical experience in two patients, *Epilepsia* 42:85, 2001.
328. **Nohria V, Giller E**, Ganaxolone, *Neurotherapeutics* 4:102, 2007.
329. **Mattson RH, Cramer JA, Caldwell BV, Siconolfi BC**, Treatment of seizures with medroxyprogesterone acetate: preliminary report, *Neurology* 34:1255, 1984.
330. **Herzog AG**, Progesterone therapy in women with complex partial and secondary generalized seizures, *Neurology* 45:1660, 1995.
331. **Herzog AG**, Progesterone therapy in women with epilepsy: a 3-year follow-up, *Neurology* 52:1917, 1999.
332. **Herzog AG**, Catamenial epilepsy: update on prevalence, pathophysiology and treatment from the findings of the NIH Progesterone Treatment Trial, *Seizure* 28:18, 2015.
333. **Valencia-Sanchez C, Crepeau AZ, Hoerth MT, Butler KA, Almader-Douglas D, Wingerchuk DM, O'Carroll CB**, Is adjunctive progesterone effective in reducing seizure frequency in patients with intractable catamenial epilepsy? A critically appraised topic, *Neurologist* 23(3):108, 2018.
334. **Frye CA, Rhodes ME, Walf A, Harney J**, Progesterone reduces pentylentetrazol-induced ictal activity of wild-type mice but not those deficient in type I 5alpha-reductase, *Epilepsia* 43(Suppl 5):14, 2002.
335. **Reddy DS, Castaneda DC, O'Malley BW, Rogawski MA**, Anticonvulsant activity of progesterone and neurosteroids in progesterone receptor knockout mice, *J Pharmacol Exp Ther* 310:230, 2004.
336. **Hall SM**, Treatment of menstrual epilepsy with a progesterone-only oral contraceptive, *Epilepsia* 18:235, 1977.
337. **Haider Y, Barnett DB**, Catamenial epilepsy and goserelin, *Lancet* 338:1530, 1991.
338. **Bauer J, Wildt L, Flugel D, Stefan H**, The effect of a synthetic GnRH analogue on catamenial epilepsy: a study in ten patients, *J Neurol* 239:284, 1992.
339. **Reid BA, Gangar KF**, Catamenial epilepsy and goserelin, *Lancet* 339:253, 1992.
340. **Hanley SP**, Asthma variation with menstruation, *Br J Dis Chest* 75:306, 1981.
341. **Enright T, Lim DT, Devnani R, Mariano R**, Cyclical exacerbations of bronchial asthma, *Ann Allergy* 58:405, 1987.
342. **Skobeloff EM, Spivey WH, Silverman RA, Eskin BA, Harchelroad FP, Alessi TV**, The effect of the menstrual cycle on asthma presentations in the emergency department, *Arch Intern Med* 156:1837, 1996.
343. **Pauli BD, Reid RL, Munt PW, Wigle RD, Forkert L**, Influence of the menstrual cycle on airway function in asthmatic and normal subjects, *Am Rev Respir Dis* 140:358, 1989.
344. **Chandler MHH, Schuldheisz S, Phillips BA, Muse KN**, Premenstrual asthma: the effect of estrogen on symptoms, pulmonary function, and b2-receptors, *Pharmacotherapy* 17:224, 1997.
345. **Ensom MH, Chong G, Zhou D, Beaudin B, Shalansky S, Bai TR**, Estradiol in premenstrual asthma: a double-blind, randomized, placebo-controlled, crossover study, *Pharmacotherapy* 23:561, 2003.
346. **Beynon HLC, Garbett ND, Barnes PJ**, Severe premenstrual exacerbations of asthma: effect of intramuscular progesterone, *Lancet* ii:370, 1988.
347. **Joseph J, Sahn SA**, Thoracic endometriosis syndrome: new observations from an analysis of 110 cases, *Am J Med* 100:164, 1996.
348. **Leong AC, Coonar AS, Lang-Lazdunski L**, Catamenial pneumothorax: surgical repair of the diaphragm and hormone treatment, *Ann R Coll Surg Engl* 88:547, 2006.
349. **Funatsu K**, Catamenial pneumothorax: an example of porous diaphragm syndromes?, *Chest* 122:1865; author reply 1865, 2002.

350. **Korom S, Canyurt H, Missbach A, Schneiter D, Kurrer MO, Haller U, Keller PJ, Furrer M, Weder W**, Catamenial pneumothorax revisited: clinical approach and systematic review of the literature, *J Thorac Cardiovasc Surg* 128:502, 2004.
351. **Alifano M, Roth T, Broet SC, Schussler O, Magdeleinat P, Regnard JF**, Catamenial pneumothorax: a prospective study, *Chest* 124:1004, 2003.
352. **Alifano M, Jablonski C, Kadiri H, Falcoz P, Gompel A, Camilleri-Broet S, Regnard JF**, Catamenial and noncatamenial, endometriosis-related or nonendometriosis-related pneumothorax referred for surgery, *Am J Respir Crit Care Med* 176:1048, 2007.
353. **Zaatari GS, Gupta PK, Bhagavan BS, Jarboe BR**, Cytopathology of pleural endometriosis, *Acta Cytol* 26:227, 1982.
354. **Granberg I, Willems JS**, Endometriosis of lung and pleura diagnosed by aspiration biopsy, *Acta Cytol* 21:295, 1977.
355. **Wang HC, Kuo PH, Kuo SH, Luh KT**, Catamenial hemoptysis from tracheobronchial endometriosis: reappraisal of diagnostic value of bronchoscopy and bronchial brush cytology, *Chest* 118:1205, 2000.
356. **Peikert T, Gillespie DJ, Cassivi SD**, Catamenial pneumothorax, *Mayo Clin Proc* 80:677, 2005.
357. **Bricelj K, Srpčič M, Ražem A, Snoj Ž**, Catamenial pneumothorax since introduction of video-assisted thoracoscopic surgery: a systematic review, *Wien Klin Wochenschr* 129(19–20):717, 2017.
358. **Elliot DL, Barker AF, Dixon LM**, Catamenial hemoptysis. New methods of diagnosis and therapy, *Chest* 87:687, 1985.
359. **Kalapura T, Okadigwe C, Fuchs Y, Veloudios A, Lombardo G**, Spiral computerized tomography and video thoracoscopy in catamenial pneumothorax, *Am J Med Sci* 319:186, 2000.
360. **Dotson RL, Peterson M, Doucette RC, Quinton R, Rawson DY, Parker Jones K**, Medical therapy for recurring catamenial pneumothorax following pleurodesis, *Obstet Gynecol* 82:656, 1993.
361. **Moya A, Sutton R, Ammirati F, Blanc J-J, Brignole M, Dahm JB, Deharo J-C, Gajek J, Gjesdal K, Krahn A, Massin M, Pepi M, Pezawas T, Ruiz Granell R, Sarasin F, Ungar A, Van Dijk JG, Walma EP, Wieling W**, Guidelines for the diagnosis and management of syncope (version 2009), *Eur Heart J* 30:2631, 2009.
362. **Muppa P, Sheldon RS, McRae M**, et al., Gynecological and menstrual disorders in women with vasovagal syncope. *Clin Auton Res*. 2013;23(3):117–122. doi:10.1007/s10286-013-0190-1
363. **Peggs KJ, Nguyen HV, Enayat D, Keller NR, Al-Hendy A, Raj SR**, Gynecological disorders and menstrual cycle lightheadedness in postural tachycardia syndrome, *Int J Gynecol Obstet* 118(3):242, 2012.
364. **Pietrucha AZ, Jędrzejczyk-Spaho J, Konduracka E, Bzukała I, Krawczyk K, Kruszelnicka-Kwiatkowska O, Nessler J**, How does the estimated phase of menstrual cycle or menopause influence the prevalence of vasovagal syncope induced by head-up tilt test, *Cardiol J* 24(5):523, 2017.
365. **Zyśko D, Gajek J, Terpilowski L, Agrawal AK, Wróblewski P, Rudnicki J**, Effects of the menstrual cycle phases on the tilt testing results in vasovagal patients, *Arch Gynecol Obstet* 286(2):429, 2012.

---

# Abnormal Uterine Bleeding

Abnormal uterine bleeding (AUB) is the single most common complaint that reproductive-age women bring to their clinicians. All clinicians who provide primary care for women must therefore be familiar with its causes and have an organized, logical approach to the evaluation and treatment of the problem.

Management of AUB requires familiarity with the reproductive endocrinology and functioning of the hypothalamo-pituitary-ovarian (HPO) axis and determinants of ovulatory response, awareness of mechanisms that underlie both onset as well as cessation of menstruation, and knowledge of the various common and uncommon gynecologic and systemic disorders that can contribute to AUB. Dysfunctions of endocrinology, disorders of physiology of ovulation, and disturbances of hematologic factors as well as local uterine anatomical structures that are important for cessation of menses can all present as AUB. A careful menstrual as well as medical history and physical examination usually provide most of the information needed to distinguish functional causes (such as anovulation) from structural causes (such as endometrial polyps, fibroids) of abnormal bleeding.

# TERMINOLOGY (OLD AND NEW)

---

Historically, clinicians have used a wide variety of terms to describe abnormal patterns of menstrual bleeding that do not always mean or communicate the same thing to others. Traditional terms ([Table 15.1](#)) having Greek or Latin roots have long been used to describe different abnormalities relating to the frequency, regularity, duration, and volume of menstrual bleeding.

## **TABLE 15.1 Traditional Terms Describing Abnormalities of Menstrual Bleeding (Old Nomenclature)**

Term	Description
Amenorrhea	Absent menses
Oligomenorrhea	Menses less frequent than every 35 days
Polymenorrhea	Menses more frequent than every 21 days
Metrorrhagia	Menses at irregular intervals
Menorrhagia	Abnormally long or heavy menses, lasting >7 d
<i>or</i>	<i>or</i>
Hypermenorrhea	Involving blood loss >80 mL

Although these definitions are reasonably well established, the terms are not always used or understood accurately.<sup>1,2</sup> For example, in the United States, the term **abnormal uterine bleeding** generally describes all abnormal patterns of bleeding that may result from a wide variety of causes, including anovulation, pregnancy, uterine pathology, and coagulopathies.<sup>3</sup> The older term **dysfunctional uterine bleeding** has been used as synonymous with anovulatory bleeding, in the absence of pregnancy or any demonstrable pathology (a diagnosis of exclusion), and the term **menorrhagia** describes regular, but heavy or prolonged, bleeding. However, in other countries, dysfunctional uterine bleeding and menorrhagia often are used to describe both ovulatory (regular) and anovulatory (irregular) bleeding that is heavy or prolonged.<sup>1</sup> The confusion surrounding the exact meaning of the traditional terms has spurred a call to abandon them, in favor of simple terms that can be understood by patients and translated easily into languages other than English, with the ultimate goal of improving communication among health care providers, investigators, and patients. To that end, recommendations arising from an international consensus conference proposed terms to describe the most important features of menstrual bleeding during the reproductive years, as shown in [Table 15.2](#).<sup>1</sup>



**TABLE 15.2 Descriptive Terms for Menstrual Abnormalities**

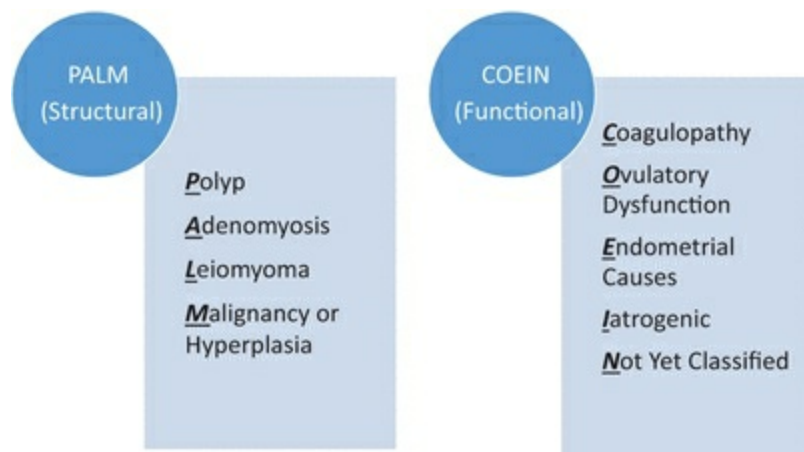
<b>Characteristic</b>	<b>Descriptive Terms</b>	<b>Normal Limits</b>
Frequency of menses	Frequent	<24 d
	Normal	24–38 d
	Infrequent	>38 d
Regularity (cycle to cycle variation)	Absent	—
	Regular	±2–20 d
	Irregular	>20 d
Duration of flow	Prolonged	>8 d
	Normal	4–8 d
	Shortened	<4 d
Volume of monthly blood loss	Heavy	>80 mL
	Normal	5–80 mL
	Light	<5 mL

The suggested normal limits for frequency, regularity, and duration of menstrual flow were based on the 5th and 95th percentiles for data drawn from population studies.<sup>4,5,6</sup> As such, they are influenced by the prevalence of common anovulatory disorders, such

as the polycystic ovary syndrome (PCOS), in a given population. Consequently, the population-based norms are wider than the generally accepted norms for menstrual frequency (24–35 days), regularity ( $\pm 5$  days variation), and duration (2–7 days) among ovulatory women. The normal limits for the volume of menstrual blood loss were based primarily on measurements of hemoglobin loss in a Swedish community.<sup>4</sup> It is important to note that, while heavy menstrual bleeding is officially defined by a volume measurement, it is more meaningful and clinically recommended to define heavy menstrual bleeding based upon its impact on a woman’s quality of life, with consideration to both objective and subjective measures. The expectation is that a structured menstrual history can clarify the details needed to categorize a patient’s complaint in clear and simple terms (e.g., irregular, heavy menstrual bleeding).<sup>7,8</sup>

### International Federation of Gynecology and Obstetrics (FIGO) Classification System for AUB: New Nomenclature

In the early 2000s, there was a global push to move away from the traditional terminology that focused on descriptives with little guidance on interpretability across regions and populations, toward a more standardized nomenclature.<sup>9,10,11,12</sup> The proposed system leaves little room for misinterpretation while allowing an appreciation of the underlying mechanisms for the clinical presentation of AUB. The differential diagnoses for AUB are comprehensively encapsulated in the acronym PALM-COEIN, as shown in **Figure 15.1**. This new classification scheme for AUB was developed by the FIGO with input from clinicians across the globe to maximize its applicability in a variety of contexts.



**FIGURE 15.1**

# NORMAL MENSTRUAL BLEEDING

---

It is ovulation (or, more specifically, the organized sequence of endocrine signals that characterizes the ovulatory cycle) that gives menses regularity, predictability, and consistency. The endocrinology of the normal menstrual cycle is discussed in detail in [Chapter 5](#). Only the most basic concepts and characteristics are summarized here, with a focus on the major events and mechanisms that control the endometrial cycle and the volume and duration of menstrual flow.

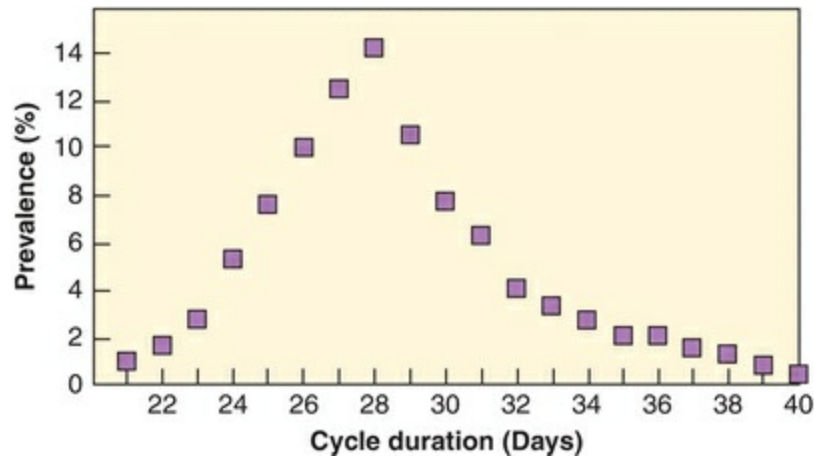
During the follicular phase of the normal ovarian cycle (corresponding to the proliferative phase of the endometrial cycle), estrogen levels rise, slowly at first and then more rapidly, as the dominant ovarian follicle emerges, grows, and matures. In response to that estrogen, the functional layer of the endometrium regrows, after having been shed during the preceding menses. After ovulation, the corpus luteum derived from the ovulatory follicle continues to produce estrogen but now (and more importantly) also progesterone. During the luteal phase of the ovarian cycle (corresponding to the secretory phase of the endometrial cycle), estrogen and progesterone levels rise together as the corpus luteum grows to maturity. In response to the combined actions of estrogen and progesterone, the endometrium transforms and organizes in preparation for the anticipated arrival and implantation of a conceptus. If pregnancy and rapidly rising levels of human chorionic gonadotropin (hCG) do not come to its “rescue,” the corpus luteum regresses spontaneously in a form of preprogrammed cell death. As it does, estrogen and progesterone levels fall steadily, eventually withdrawing the functional support for the endometrium. Menses begin, marking the end of one endometrial cycle and the beginning of another.

From the endometrial perspective, the endocrine features of the ovarian cycle are quite simple; the quantities of hormones produced are not nearly as important as the sequence in which they appear: estrogen, followed by estrogen and progesterone, followed by withdrawal of both hormones. Of all the different hormone effects on the endometrium, estrogen-progesterone stimulation produces the most stable endometrium, and their combined withdrawal yields the most consistent menstrual characteristics. **The sequence is so controlling that most ovulatory women have a pattern, volume, and duration of menstrual flow they recognize as their own and come to expect, very often accompanied by an equally consistent and predictable pattern of premenstrual molimina (such as bloating, breast tenderness, and mood swings).** Even slight deviations from the usual pattern in the timing, amount, or length of flow can cause concern. Careful attention to the finer details of the menstrual history can be very helpful in distinguishing anovulatory bleeding from other causes.

Variations in menstrual flow and cycle length are common at the extremes of

reproductive age (i.e., during the early teenage years and those preceding the menopause). Menstrual cycles often are irregular for the first 12–18 months after menarche, due to immaturity of the HPO axis.<sup>13,14</sup> In a study conducted by the World Health Organization, the median length of the first cycle after menarche was 34 days; almost 40% of cycles were longer than 40 days and fewer than 10% were less than 20 days.<sup>15</sup> Cycles remain relatively long for the first 5–7 years after menarche, thereafter decreasing gradually in length and becoming more regular.<sup>15</sup> The prevalence of anovulatory cycles is higher in women under age 20 and over age 40.<sup>16,17</sup> Menstrual cycle characteristics generally do not change appreciably during the reproductive years,<sup>6</sup> although overall cycle length and variability slowly decrease. On average, mean cycle length and range reach their lows at about age 40–42.<sup>6,18</sup> Over the subsequent 8–10 years before the menopause, the trend is reversed; both average cycle length and variability increase steadily as ovulation becomes less regular and frequent.<sup>5,18,19,20</sup> Mean cycle length is greater in women at the extremes of body mass and composition; both high and low body mass index (BMI), body fat mass, and body lean mass are associated with an increased mean cycle length.<sup>21,22</sup>

In general, variations in cycle length reflect differences in the length of the follicular phase of the ovarian cycle (**Figure 15.2**). Women who have a 25-day cycle ovulate on or about cycle day 10–12, and those with a 35-day cycle ovulate approximately 10 days later. Within a few years after menarche, the luteal phase becomes extremely consistent (13–15 days in duration) and remains so until the perimenopause.<sup>5,18</sup> At age 25, over 40% of cycles are between 25 and 28 days in length, and between age 25 and 35, over 60% are. **Although 28 days is the most commonly reported intermenstrual interval, only approximately 15% of cycles among reproductive-aged women actually are 28 days in length.** Less than 1% of women have a regular cycle lasting less than 24 days or more than 35 days.<sup>23</sup> Most women have cycles that last from 24 to 35 days, but at least 20% of women experience irregular cycles.<sup>6</sup>



**FIGURE 15.2**

The usual duration of menstrual flow is 4–6 days, but for some women (approximately 3%), menses may last as few as 2 days or as many as 7 days.<sup>24</sup> The average volume of menstrual blood loss is approximately 30 mL<sup>4</sup>; greater than 80 mL is abnormal. Flow can be excessive without being abnormally long because most of the menstrual blood loss occurs during the first 3 days.<sup>25,26</sup>

**Women who menstruate more often than every 24 days or less often than every 35 days deserve evaluation,<sup>5,6</sup> as do those who consistently flow for more than 7 days and women with monthly menstrual blood loss exceeding 80 mL.** Any of these abnormal patterns can result in anemia that also requires treatment.<sup>27,28</sup> The intermenstrual interval and duration of menses are relatively easy to determine, but the volume of menstrual blood loss is difficult to measure. The correlation between perceived and actual blood loss is relatively poor.<sup>29</sup> In population-based studies, one-fourth to one-third of women with normal periods considered their menstrual blood loss excessive, and 40% of those with documented menorrhagia (blood loss >80 mL) described their menses as light or moderate.<sup>4,30</sup> Complaints of heavy menstrual bleeding appear to relate more to perceived interference with daily function than to actual blood loss,<sup>31</sup> and evidence indicates that psychosocial factors may have significant influence on those perceptions; the incidence of depression and anxiety is increased among women with complaints of heavy menstrual bleeding.<sup>32,33,34</sup>

# Mechanisms Controlling Onset and Cessation of Normal Menstruation

A conceptual understanding of the mechanisms involved in the onset and cessation of normal menstrual bleeding provides both the foundation and the context for understanding the pathophysiology of anovulatory bleeding.

The classic concepts of normal menstruation derived primarily from direct observations of the cyclic changes in endometrium transplanted from the uterus to the anterior chamber of the eye in nonhuman primates; vascular events played the key role in the explanation of how menses both began and ended.<sup>35,36</sup> Basically, menstruation was envisioned as ischemic necrosis of the endometrium caused by vasoconstriction of the spiral arterioles in the basal layer, triggered by withdrawal of estrogen and progesterone. Similarly, the end of menses was explained by longer and more intense waves of vasoconstriction, combined with coagulation mechanisms activated by vascular stasis and endometrial collapse, aided by rapid reepithelialization mediated by estrogen derived from the emerging new follicular cohort.

The results of more contemporary investigations do not support the classic hypoxia theory of menstruation. Perfusion studies in women have failed to demonstrate reduced endometrial blood flow just before menses.<sup>37</sup> Hypoxia-inducible factor (HIF)-1, a nuclear protein that activates gene transcription in response to reduced cellular oxygen (the earliest known marker of response to hypoxia), is barely detectable and not widely distributed in human premenstrual endometrium cultured under hypoxic conditions.<sup>38</sup> Histologically, early menstrual endometrium exhibits focal necrosis, inflammation, and coagulation rather than the diffuse hyalinization or coagulation necrosis that would be expected to result from vasoconstriction and hypoxia.<sup>39</sup> Thus, the operational paradigm for menstruation has shifted. **Instead of vascular events, the central theme of the current model of the initiation of menstruation is an enzymatic autodigestion of the functional layer of the endometrium and its subsurface capillary plexus, possibly extending to the spiral arteriolar system in the basal layer.**<sup>39</sup> **The classic concept of the mechanisms that end normal menstruation is essentially unchanged; coagulation mechanisms, local vasoconstriction, and reepithelialization all contribute to hemostasis in the menstrual endometrium with vascular events playing the key role.**

The enzymatic degradation of the endometrium triggered by estrogen-progesterone withdrawal involves a number of different but interrelated mechanisms including the release of intracellular lysosomal enzymes, proteases from infiltrating inflammatory cells, and the actions of matrix metalloproteinases (MMPs). In the first half of the

secretory phase, acid phosphatase and other potent lytic enzymes are confined to intracellular lysosomes, their release inhibited by progesterone via stabilization of lysosomal membranes. As estrogen and progesterone levels fall in the days preceding menses, lysosomal membranes destabilize, and the enzymes within are released into the cytoplasm of epithelial, stromal, and endothelial cells and, eventually, into the intercellular space. These proteolytic enzymes digest their cellular constraints as well as surface membranes and desmosomes (intercellular bridges). In the vascular endothelium, their actions result in platelet deposition, prostaglandin release, vascular thrombosis, extravasation of red blood cells, and tissue necrosis.<sup>39,40</sup>

Progesterone withdrawal also stimulates an inflammatory response in the endometrium. Just before menstruation, the total number of leukocytes in the endometrium increases markedly to as much as 40% of the stroma.<sup>41,42</sup> The inflammatory infiltrate (including neutrophils, eosinophils, and macrophages or monocytes) is drawn by chemoattractive molecules (chemokines) synthesized by endometrial cells, some of which are down-regulated by progesterone (such as IL-8 and MCP-1).<sup>41</sup> When activated, the leukocytes produce a wide assortment of regulatory molecules including cytokines, chemokines, and a range of enzymes (including MMPs) that contribute to degradation of the extracellular matrix, directly or indirectly, via activation of other proteases.

Matrix metalloproteinases are a family of proteolytic enzymes that degrade components of the extracellular matrix and basement membrane.<sup>43</sup> The metalloproteinases include collagenases that degrade interstitial and basement membrane collagens, gelatinases that further digest collagens, and stromelysins that attack fibronectin, laminin, and glycoproteins. Each member of the family is substrate specific and secreted as an inactive zymogen that requires activation by plasmin, leukocyte proteases, or other metalloproteinases. The expression, secretion, and activation of endometrial MMPs are cycle dependent and increases markedly in the late secretory phase just before menstruation.<sup>44,45</sup> Overall, progesterone inhibits endometrial metalloproteinase expression, an action mediated by transforming growth factor beta (TGF- $\beta$ ).<sup>46</sup> Progesterone withdrawal has the opposite effect—increased metalloproteinase secretion and activation, followed by dissolution of the extracellular matrix.<sup>47</sup> Local modulators (predominantly cytokines), derived from endometrial epithelial, stromal, and endothelial cells, and natural tissue inhibitors of MMPs (which bind the active form of the enzymes) also play an important role in their regulation.<sup>48</sup> In cycles of conception wherein elevated progesterone levels are sustained, MMP activity remains effectively suppressed. In the normal menstrual cycle, metalloproteinase expression is suppressed again after menses, presumably by increasing estrogen levels.

Progressive enzymatic degradation of the endometrium eventually disrupts the



subsurface capillary and venous vascular system, causing interstitial hemorrhage; dissolution of the surface membrane allows blood to escape into the endometrial cavity. Ultimately, degeneration extends to the deepest extent of the functional layer where rupture of the basal arterioles contributes to bleeding. A natural cleavage plane develops at the junction of the loose, vascular, edematous stroma with the basal layer. Desquamation begins in the fundus and gradually extends toward the isthmus. The end result is the typical deflated and shallow but dense menstrual endometrium.<sup>49,50</sup>

The menstrual fluid is comprised of an autolyzed endometrium rich in inflammatory exudates, red blood cells, and proteolytic enzymes.<sup>39,50</sup> One of those enzymes, plasmin (formed by activation of its inactive precursor, plasminogen), has potent fibrinolytic actions that help to prevent clotting of menstrual fluid and to facilitate the expulsion of degenerated tissue. Plasminogen activators that mediate the conversion of plasminogen to plasmin are found in late secretory and menstrual endometrium and are released from degenerated endometrial vascular endothelium.<sup>39,50</sup> The volume of menstrual bleeding is controlled, at least to some extent, by the local balance between fibrinolysis and clotting. Endometrial stromal cell tissue factor and plasminogen activator inhibitor (PAI)-1 promote clotting and help to balance fibrinolytic processes.<sup>51,52,53</sup> Early in menstruation, intravascular platelet plugs (and, later, thrombi) form at the shedding surface, helping to limit blood loss. Their importance to hemostasis in the menstrual endometrium can be inferred from the increased volumes of menstrual blood loss observed in women with thrombocytopenia and von Willebrand disease. Ultimately, however, the cessation of menstrual bleeding depends on vasoconstriction in the denuded spiral arterioles in the basal layer of the endometrium and also possibly in the radial arteries of the superficial myometrium. Endothelins are potent long-acting vasoconstrictors of vascular smooth muscle produced by endometrial glandular, stromal, and endothelial cells. Menstrual endometrium contains high concentrations of endothelins and prostaglandins, which together cause intense vasoconstriction in the spiral arterioles.<sup>39</sup> The myometrial contractions associated with menstrual events very likely reflect the actions of prostaglandin  $F_{2\alpha}$ ; however, in contrast to postpartum bleeding, myometrial contractions are not important for control of menstrual bleeding.

Surface reepithelialization also contributes to hemostasis in the menstrual endometrium. The process occurs very rapidly, beginning at the mouth of the basal portions of residual glands in areas otherwise completely denuded and spreading outward. The peripheral regions of the cavity at the isthmus and near the tubal ostia (which do not shed during menses) also contribute to its resurfacing.<sup>42,50</sup> Generally, by cycle day 5, these scattered areas of epithelial proliferation converge and fuse; bleeding stops completely only when the new epithelial surface is complete. The mechanisms that govern this initial phase of tissue repair and the role that estrogen has, if any, are

uncertain. In the first few days of the new cycle, circulating estrogen levels and endometrial estrogen and progesterone receptor concentrations are low and unchanged from premenstrual levels.<sup>54,55</sup> Moreover, even after oophorectomy and vigorous endometrial denudation, the endometrium heals, suggesting that the initial phase of tissue repair is largely independent of estrogen.<sup>42,50</sup>

The stroma regenerates from stem cells located in the basal layer of the endometrium but only after a confluent surface epithelium has been restored. Damaged endometrial vessels are quickly repaired. New vessel growth and mitotic activity in all parts of the regenerated human endometrium coincide with increasing serum estrogen levels and rising endometrial estrogen and progesterone receptor concentrations.<sup>42,50</sup> MMPs present in the menstrual endometrium and other proteases may be important mediators of the release and activation of growth factors needed for endometrial repair. Vascular endothelial growth factor (VEGF) is an important promoter of endometrial mitosis and can be induced by tumor necrosis factor (TNF)- $\alpha$ , TGF- $\beta$ , and insulin-like growth factor-1.<sup>39,56,57</sup> Experimental evidence derived from model systems suggests that activins and other members of the TGF- $\beta$  superfamily also may play a role.<sup>42,58</sup>

**There are two basic reasons why normal menstrual bleeding is self-limited.**

1. In response to a simultaneous estrogen-progesterone withdrawal, endometrial shedding is universal. Because the onset and end of menses relate to organized cyclic hormonal events, menstrual changes occur uniformly, throughout the endometrial cavity. Shedding of the functional layer and exposure of the basal regenerative layer of the endometrium stimulate coagulation, vasoconstriction, and epithelial reconstruction mechanisms that effectively limit the volume and duration of bleeding.
2. In response to cyclic sequential estrogen-progesterone stimulation, growth and development of the endometrial epithelium, stroma, and microvasculature is structurally stable and random breakdown is avoided. The sequence of events leading to the enzymatic disintegration of the endometrium proceeds in an orderly and synchronous fashion. The endometrium is not just repaired, but is completely remodeled, at regular intervals.

# **ENDOMETRIAL RESPONSES TO STEROID HORMONES: PHYSIOLOGIC AND PHARMACOLOGIC**

---

The normal menstrual bleeding that occurs at the end of an ovulatory cycle results from estrogen-progesterone withdrawal. The same mechanism operates when the corpus luteum is removed or when its gonadotropin support is suddenly interrupted during the luteal phase, such as by treatment with a gonadotropin-releasing hormone (GnRH) antagonist. Other examples include the bleeding that follows discontinuation of both estrogen and progesterone in women receiving cyclic postmenopausal hormone therapy and the bleeding that comes at the end of a standard cycle of treatment with an estrogen-progestin contraceptive. The bleeding that follows estrogen-progesterone withdrawal generally is regular, predictable, and consistent in volume and duration. However, estrogen-progesterone withdrawal is not the only pattern of steroid hormone signals that can provoke endometrial bleeding. Bleeding also can result from estrogen withdrawal, estrogen breakthrough, progestogen withdrawal, and progestogen breakthrough.

# **Estrogen Withdrawal Bleeding**

One clinical example of estrogen withdrawal bleeding is that which may follow bilateral oophorectomy during the follicular phase of the cycle. The bleeding that occurs after removal of the ovaries can be delayed by exogenous estrogen therapy but will occur when treatment stops. Other examples include cyclic estrogen-only hormone therapy in castrate or postmenopausal women and the midcycle bleeding that can accompany the transient but abrupt fall in estrogen levels immediately preceding and following ovulation.

# Estrogen Breakthrough Bleeding

The best clinical examples of estrogen breakthrough bleeding are the different patterns of bleeding observed in women with chronic anovulation. The amount and duration of estrogen breakthrough bleeding can vary widely, depending on the amount and duration of unopposed estrogen stimulation that the endometrium has received. **Relatively low levels of chronic estrogen exposure typically result in intermittent spotting or staining that is generally light in volume but may be prolonged. In contrast, sustained high-level estrogen stimulation commonly results in long intervals of amenorrhea punctuated by acute episodes of often profuse bleeding that vary in duration and can be severe enough to necessitate emergent care.**

# Progestogen Withdrawal Bleeding

Progestogen withdrawal bleeding is observed when treatment with exogenous progesterone or a synthetic progestin is discontinued. **Progestogen withdrawal bleeding occurs only when the endometrium has first been primed with estrogen (endogenous or exogenous).** The amount and duration of bleeding can vary widely and generally correlate with the level and duration of previous estrogen-stimulated endometrial proliferation. In women with marginal to frankly low estrogen levels or short intervals of amenorrhea, bleeding is generally light to scant and may not occur at all. In those with sustained high estrogen levels or long intervals of amenorrhea, bleeding can be heavy and somewhat prolonged but still is self-limited. Between the extremes, the amount and duration of bleeding induced by progestogen withdrawal are typically similar to that observed at the end of a normal ovulatory cycle. In women receiving cyclic hormone therapy with exogenous estrogen and progestin, bleeding follows withdrawal of progestin even if estrogen treatment continues; progestin withdrawal bleeding can be delayed but only if estrogen levels are increased by 10- to 20-fold.<sup>59</sup>

# Progestogen Breakthrough Bleeding

Progestogen breakthrough bleeding occurs when the ratio of progestogen to estrogen is unfavorably high. Unless there is sufficient estrogen to balance its action, continuous treatment with exogenous progesterone or synthetic progestins will result in intermittent bleeding of varying duration that is generally light, a pattern very similar to low-level estrogen breakthrough bleeding described above. Clinical examples of progestogen breakthrough bleeding are the bleeding observed in women using the progestin-only contraceptive “minipill” or other long-acting progestin-only contraceptive methods (such as progestin implants or depot medroxyprogesterone acetate).<sup>60</sup> The breakthrough bleeding observed in women using combination estrogen-progestin contraceptives also is a form of progestogen breakthrough bleeding. Such breakthrough bleeding is more common with contraceptives containing a lower estradiol dose but can be seen with any combination hormonal formulation.<sup>61</sup> **Although all estrogen-progestin contraceptive regimens contain pharmacologic quantities of both estrogen and progestin, the progestin component is always the dominant hormone, and the net effect on the endometrium is profoundly progestational.**

# PATHOPHYSIOLOGY OF ANOVULATORY BLEEDING

---

Anovulatory bleeding can result from estrogen withdrawal bleeding, reflecting the transient fall in estrogen levels that accompanies spontaneous regression of a follicular cohort. More commonly, however, AUB in anovulatory women reflects estrogen breakthrough bleeding, due to focal breakdown of an overgrown and structurally fragile endometrium under continuous estrogen stimulation. The heaviest episodes of anovulatory bleeding tend to occur in women following prolonged periods of exposure to estrogen, unopposed by progesterone, such as in women with PCOS, obese women, postmenarcheal adolescents, and perimenopausal women. The clinical presentation spans the spectrum from the pale frightened teenager who has bled for weeks to the older woman who is deeply concerned that she may have cancer.

In contrast to the organized predictable pattern of sequential estrogen-progesterone stimulation and withdrawal that characterizes the normal ovulatory menstrual cycle, the patterns of ovarian steroid hormone production and endometrial stimulation in anovulatory women are disorganized and unpredictable. By definition, the anovulatory woman is always in the follicular phase of the ovarian cycle and in the proliferative phase of the endometrial cycle. There is no luteal or secretory phase because there is no ovulation or cycle. The only ovarian steroid signal the endometrium receives is estrogen, levels of which constantly fluctuate, rising and falling as each new cohort of follicles begins to grow, but ultimately loses its developmental momentum and, sooner or later, lapses into atresia. Although the amplitude of the signal (estrogen contributed by inefficient follicular growth) may vary, the message for endometrial growth stays the same.

Over a period of time, an unrelenting, uninterrupted estrogen signal can stimulate the endometrium to proliferate to achieve abnormal degrees of thickness where the tissue outgrows its own blood supply and becomes fragile. Without the growth-limiting and growth-organizing effects of progesterone, the endometrium lacks the stromal support structure to maintain stability. Focal areas break down and bleed; as those areas heal under the influence of continued estrogen stimulation, others break down and bleed. Persistent proliferative and hyperplastic endometrium characteristically exhibits numerous discrete foci of stromal breakdown near the epithelial surface, associated with pools of extravasated red blood cells, capillary platelet/fibrin thrombi, and repair-related changes recognized as ball-like aggregates of tightly packed stromal cells beneath a cap of intact but hypertrophied epithelium.<sup>39</sup> The cause for the focal breakdowns in persistent proliferative endometrium is not entirely clear.

Abnormal endometrial growth involves not only epithelial and stromal cells but



also the microvasculature. Venous capillaries in persistent proliferative and hyperplastic endometrium are increased, dilated, and often form abnormal irregular channels; ultrastructural studies have revealed a number of abnormal structural elements that predispose to fragility.<sup>62,63</sup> The abnormal microvasculature could be the result, but is more likely the proximate cause, of abnormal bleeding. **The weight of available evidence from histologic and molecular studies indicates that anovulatory bleeding results from an increased density of abnormal vessels having a fragile structure prone to focal rupture, followed by release of lysosomal proteolytic enzymes from surrounding epithelial and stromal cells and migratory leukocytes and macrophages.** Once initiated, the process is further aggravated by local release of prostaglandins, with greater sensitivity to those that vasodilate (PGE<sub>2</sub>) than to those that vasoconstrict (PGF<sub>2α</sub>).<sup>64</sup> Other molecules (perforins) inhibit capillary plug formation and further degrade the capillary venous network. Vasoconstriction of basal endometrial and superficial myometrial vessels does not occur because tissue loss is only focal and superficial and does not typically reach the basal layer where denudation triggers an intense vasoconstrictive response. The final mechanism that normally controls menstrual bleeding, surface epithelial reconstruction, operates in persistent proliferative endometrium, but not in a normal way. Epithelial repair is focal, in the areas of breakdown, and not universal; the result is a constantly changing patchwork of small repairs instead of an organized and well-structured remodeling as what follows after the endometrial shedding of normal menstruation.<sup>39</sup>

# DIFFERENTIAL DIAGNOSIS OF ABNORMAL UTERINE BLEEDING

---

The differential diagnoses for AUB include a wide spectrum of possibilities that range from pregnancy to ovulation disorders, uterine/vaginal/cervical abnormalities (benign and malignant), trauma, infection, coagulopathies, endocrine disorders, foreign bodies, systemic disease, to bleeding relating to medications. **The prevalent causes of AUB vary with age.** In premenarcheal girls, foreign bodies, trauma, and infection are the most common. In postmenarcheal adolescents, anovulatory bleeding, coagulopathies, infections, and complications of pregnancy head the list. During the reproductive years, most abnormal bleeding results from anovulation, hormonal contraception, complications of pregnancy, infections, endocrine disorders, and polyps and myomas. In perimenopausal women, anovulation, benign uterine neoplasia, and endometrial hyperplasia cause the majority of problems, and in postmenopausal women, vaginal/endometrial atrophy and hormone therapy are the most common causes of abnormal bleeding; only about 10% of postmenopausal bleeding results from endometrial cancer.

**Complications of pregnancy** always should be considered and excluded, particularly in adolescents who may be reluctant to reveal their sexual history. **It is important to emphasize that the most common cause of a sudden departure from a well-established pattern of regular and predictable menses is a complication of pregnancy; threatened or spontaneous abortion and ectopic pregnancy are the most common, but possibilities also include retained products of conception and gestational trophoblastic disease.**

The PALM portion of the FIGO classification acronym encompasses structural causes for AUB: **polyps, adenomyosis, leiomyomata, and malignancy/hyperplasia (Figure 15.1).** Two-thirds of women with endometrial polyps will experience AUB, with intermenstrual bleeding and heavy menses as the most common patterns. Women with adenomyosis are more likely to experience heavy menses but may instead have intermenstrual bleeding (or dysmenorrhea alone). Myomas generally cause heavy menstrual bleeding, which is mediated by alteration to the usual hemostatic mechanisms of the uterus through changes in vascular compression and the release of vasoactive growth factors. Women with malignancy or hyperplasia may have a variety of abnormal bleeding patterns, including intermenstrual bleeding, frequent menses, or heavy or prolonged bleeding. **Nonstructural causes of AUB are represented in the “COEIN” portion of the PALM-COEIN acronym, where COEIN stands for coagulopathy, ovulatory dysfunction, endometrial factors, iatrogenic, and “not yet classified.”**

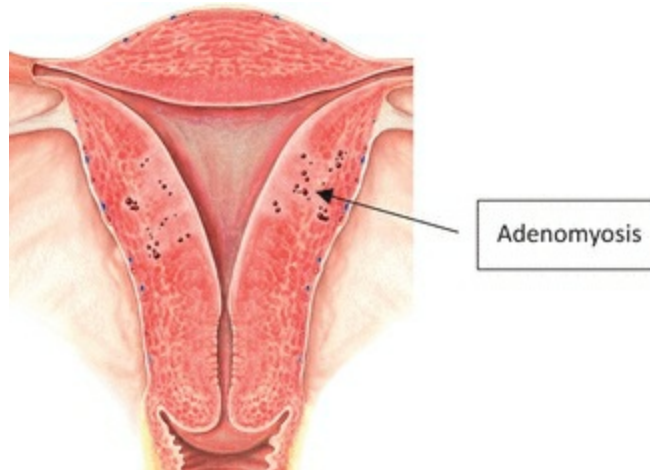
## AUB-P (Polyps) (Figure 15.3)



Modified from **Anatomical Chart Company**, Common Gynecological Disorders Anatomical Chart, Wolters Kluwer, Philadelphia, 2007.

Endometrial polyps often cause abnormal bleeding, most likely due to vascular fragility, chronic inflammation, and surface erosions. Larger pedunculated polyps may develop ischemic necrosis at their apex that extends to the subsurface capillaries as a consequence of intermittent torsion and related thrombosis.

## AUB-A (Adenomyosis) (Figure 15.4)



Modified from **Anatomical Chart Company**, Common Gynecological Disorders Anatomical Chart, Wolters Kluwer, Philadelphia, 2007.

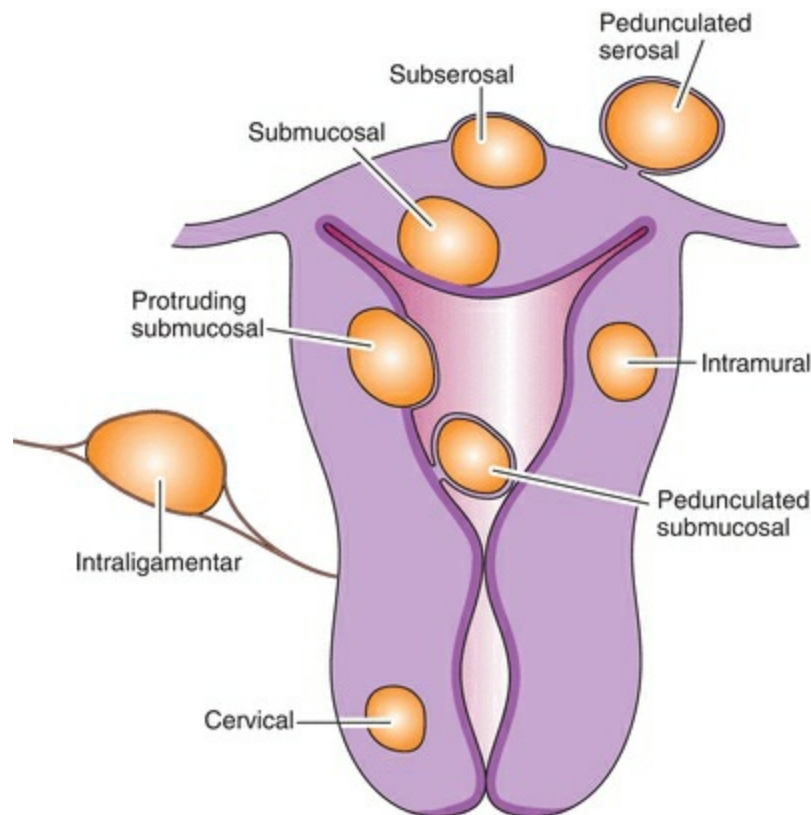
Adenomyosis is a disorder characterized by the extension of endometrial glands and stroma into the myometrium, a relatively common finding in hysterectomy specimens from women with menorrhagia unrelated to uterine myomas or endometrial pathology. Hypertrophy and hyperplasia in the surrounding myometrium generally result in diffuse uterine enlargement.<sup>65</sup> However, some women develop focal nodular lesions called adenomyomas (exaggerated myometrial proliferation around foci of ectopic endometrium), which resemble leiomyomas clinically. The pathogenesis of adenomyosis and associated menorrhagia is unknown. The disease may develop from endomyometrial invagination of the endometrium or develop de novo from müllerian rests.<sup>66,67,68</sup>

In symptomatic women, transvaginal ultrasonography can suggest the diagnosis; while asymmetric thickening and heterogeneity of the myometrium are suggestive features, myometrial cysts are the most specific diagnostic criterion.<sup>69</sup> A meta-analysis including 14 studies involving women who had ultrasonography performed before hysterectomy found that sonography has 83% sensitivity and 85% specificity for diagnosis of adenomyosis.<sup>70</sup> Magnetic resonance imaging (MRI) is a more sensitive diagnostic technique,<sup>71</sup> particularly in the presence of uterine myomas; thickening of the junctional zone on T2-weighted imaging is characteristic.<sup>65,69,72</sup> However, the costs of MRI are difficult to justify if the results do not affect clinical management. In recent years, a role of hysteroscopy in diagnosing adenomyosis has also emerged; irregular appearance of the endometrium and evidence of hemorrhagic foci are suspicious for

underlying adenomyosis, and use of a resectoscope also allows an opportunity for confirming a histologic diagnosis in appropriately selected cases.<sup>73,74,75</sup>

## AUB-L (Leiomyoma)

Uterine leiomyomas are extremely common (Figure 15.5). Heavy menstrual bleeding is the most common form of AUB encountered in women with fibroids, although most women with uterine fibroids do not experience abnormal bleeding. The high prevalence of uterine myomas guarantees that they will often be identified in women who are undergoing gynecologic evaluation for any form of AUB or even reasons other gynecologic disorders. **Myomas cannot, therefore, be regarded as the cause of abnormal bleeding before other obvious possibilities have been excluded, particularly when they do not protrude into or displace the uterine cavity.** Fibroids may be the cause of heavy or prolonged bleeding in ovulatory women; they may aggravate the bleeding that results from anovulation or other causes. Many times, uterine fibroids represent only an incidental finding. Transvaginal ultrasonography generally provides accurate information regarding the size, number, and location of myomas, but images can be difficult to interpret when fibroids are multiple and large. Sonohysterography more clearly defines the proximity of myomas to the uterine cavity and can thus help to differentiate clinically relevant myomas from those that are not.<sup>76</sup>



**FIGURE 15.5**

The mechanisms by which uterine myomas may cause abnormal bleeding are not entirely clear but seem closely related to their location. Histologic studies suggest that submucous and large deep intramural myomas cause the overlying endometrium to stretch. Compression from below and trauma from intracavitary friction at the epithelial surface combine to cause focal chronic inflammation or even ulceration, resulting in bleeding.<sup>77</sup> In compressed or damaged endometrium, other hemostatic mechanisms like platelet plug formation also may be impaired. Erosion and rupture of the larger caliber surface vessels observed on some myomas can further contribute to prolonged or heavy bleeding.<sup>39,78</sup> The greater surface area of a grossly enlarged uterine cavity probably explains menorrhagia in women with fibroids that are numerous and large but distant from the endometrium.

## AUB-M (Malignancy or Hyperplasia)

Endometrial hyperplasia is a histologic diagnosis based on findings of proliferating glands of varying size and shape and a greater gland-to-stroma ratio than is observed in normal endometrium.<sup>79</sup> Endometrial hyperplasia results almost exclusively from unopposed chronic estrogen stimulation.

Historically, endometrial hyperplasia was classified as simple or complex (reflecting the architectural pattern), with or without nuclear atypia (enlargement, rounding, pleomorphism, and aneuploidy). The simple and complex designations, based upon the gland-to-stroma ratio in the endometrium, were abandoned by the World Health Organization in 2014,<sup>80</sup> both to simplify terminology and to reflect the molecular understanding that only the presence of atypia is reflective of the genetic changes seen in the development of invasive endometrial cancer. Lesions without atypia basically represent only exaggerated forms of persistent proliferative endometrium; they regress spontaneously, after curettage or with progestin treatment, and are associated with little risk (1–3%) for progression to adenocarcinoma.<sup>81,82,83,84</sup> In contrast, atypical endometrial hyperplasia exhibits an entirely different behavior; it does not often spontaneously regress and can be quite resistant to even repeated curettage or prolonged high-dose progestational therapy. **Endometrial hyperplasia with atypia has significant risk (10–30%) of progression to adenocarcinoma if left untreated and must therefore be regarded as a precancerous lesion.**<sup>81,82,83,84</sup> Atypical lesions are distinguished from invasive carcinomas by the absence of stromal invasion. It is important to note that, despite concerted efforts to standardize classification criteria, there is significant interobserver variability in the classification assigned by pathologists, even within the same institution.<sup>85,86</sup> Other classification systems have been proposed,<sup>87,88</sup> but none has gained wide acceptance.

**When an office biopsy (discussed under evaluation) reveals endometrial hyperplasia, further evaluation is required to exclude atypia or a coexisting cancer that was not represented in the tissue specimen, and if subsequent curettage reveals atypical endometrial hyperplasia, there is significant risk of an unrecognized adenocarcinoma.** In a retrospective study involving 824 women with a diagnosis of complex atypical hyperplasia after office sampling, 100 were diagnosed with cancer after further evaluation with curettage, but 298 of the remaining 724 (41%) had unexpected cancer in a hysterectomy specimen obtained within 6 months of the original diagnosis; among those having an occult cancer, 30% had been further evaluated with curettage and 45% had not.<sup>89</sup>



## AUB-C (Coagulation or Bleeding Disorders)

The possibility of a coagulopathy should be particularly kept in mind, particularly for adolescents whose menstrual history is short and not yet well defined. The most common cause of AUB in adolescents is anovulation, but up to a third may have a coagulation defect,<sup>90,91,92,93</sup> including von Willebrand disease, Glanzmann thrombasthenia, and idiopathic thrombocytopenic purpura. In patients diagnosed with malignancy, platelet dysfunction and thrombocytopenia may be related to the underlying cancer or result from treatment of malignancy. Bleeding disorders usually are associated with cyclic, regular, heavy, or prolonged bleeding (older terminology, menorrhagia). The same pattern may be observed in women receiving treatment with anticoagulants.<sup>94</sup> **Previous history of postpartum hemorrhage or excessive bleeding with surgery, dental procedures, or trauma should raise suspicion, but heavy menstrual bleeding since menarche may be the only clue.**<sup>95</sup> **Coagulation defects are not as rare as is generally perceived and may be found in 10–20% of women with unexplained heavy menses.**<sup>95,96,97,98</sup> Numerous studies have documented the association between heavy menstrual bleeding and inherited coagulation defects.<sup>95,96,97,99,100,101</sup> Combined, they provide ample justification for performing screening coagulation studies in women with long-standing and unexplained heavy menstrual flow.

**Von Willebrand disease is the most common inherited bleeding abnormality affecting women.** The disease is the consequence of quantitative or qualitative defects of von Willebrand factor, a protein that plays an important role in primary hemostasis by binding to both platelets and the vascular endothelium, forming a bridge between them and adjacent platelets at the site of injury.<sup>102,103</sup> By serving as a carrier protein for factor VIII and thereby prolonging its half-life in the circulation, von Willebrand factor also contributes to fibrin clot formation. There are three types of inherited von Willebrand disease.<sup>104,105,106</sup> The tendency of excess bleeding can vary widely, even within individuals and their families. There are also acquired forms of von Willebrand disease associated with a variety of different diseases ([Table 15.3](#)).

### TABLE 15.3 Types of von Willebrand Disease

Type	Inheritance	Characteristics
I	Autosomal dominant	Most common variant (85%) Results from <i>quantitative</i> deficiency of von Willebrand factor
II	Autosomal dominant	Has four subtypes ALL of which involve <i>qualitative</i> abnormalities of von Willebrand factor
III	Autosomal recessive	Rare Total deficiency of von Willebrand factor—this results in the most severe form of coagulopathy

## **AUB-O (Ovulatory Dysfunction)**

Anovulatory bleeding (previously referred to as “dysfunctional uterine bleeding”) describes the spectrum of abnormal bleeding patterns that can occur in anovulatory women. The mechanisms involved in anovulatory bleeding reflect an abnormal pattern of steroid hormone stimulation that deviates from the sequence characterizing the normal ovulatory menstrual cycle. Anovulation and oligoovulation can result from a variety of endocrinologic disturbances either directly involving or influencing the functioning of the HPO axis, including thyroid disease (hyper- and hypothyroidism), hyperprolactinemia, PCOS, and hypothalamic dysfunction from nutritional deficiency, systemic illness, or stress. In the case of **systemic illnesses** that predispose to anovulation, the abnormal bleeding can be compounded by concomitant coagulation abnormalities; for example, chronic renal disease is associated with both ovulatory and platelet dysfunction, while liver disease can adversely affect estrogen metabolism (predisposing to anovulation) and impair the synthesis of clotting factors. Many of the endocrinopathies predisposing to or characterized by anovulation are discussed in further detail in other chapters of this textbook.

## **AUB-E (Endometrial)**

Endometrial causes of AUB other than the polyps and the fibroids discussed earlier (particularly the submucous myomas that distort the endometrium) are less common. Chronic endometritis is a poorly understood entity that can be categorized under endometrial cause as much as under the “not otherwise specified” category, as discussed below. Acute endometritis in the postpartum or postabortal period is a well-defined entity that can cause heavy menstrual bleeding. Abnormal bleeding has also been described in patients with subclinical *Chlamydia trachomatis* infections, pelvic tuberculosis, and pelvic inflammatory disease. Bleeding abnormalities associated with placental site nodule belong under this category.<sup>107</sup>

## AUB-I (Iatrogenic)

A variety of different **medications** can predispose to abnormal bleeding, by interfering with hemostasis (usually resulting in menorrhagia), by affecting the concentrations of endogenous or exogenous hormones (causing fluctuations in circulating levels), or by disrupting the HPO axis. Drugs associated with abnormal menstrual bleeding include hormonal contraceptives, those used for postmenopausal hormone therapy, digitalis, anticonvulsants, anticoagulants, and psychopharmacologic medications. Some common herbs have estrogenic activity (e.g., ginseng) and may be associated with abnormal bleeding.<sup>108</sup> Use of various forms of **hormonal contraceptives is probably the most common iatrogenic cause of abnormal bleeding in reproductive-age women. Similarly**, abnormal bleeding is well described in users of **menopausal hormone therapy**. When assessing women experiencing AUB who are on hormone regimens, the possibility of issues of compliance as well as of underlying pathology must be given consideration. Abnormal bleeding patterns are commonly reported in association with both copper (Cu) and levonorgestrel (LNG)-containing intrauterine contraceptive device (IUD) use; whereas heavy menstrual bleeding is often encountered with use of Cu-containing IUDs, erratic spotting is more common in the initial few months following placement of LNG-IUD, followed by eventual development of amenorrhea.

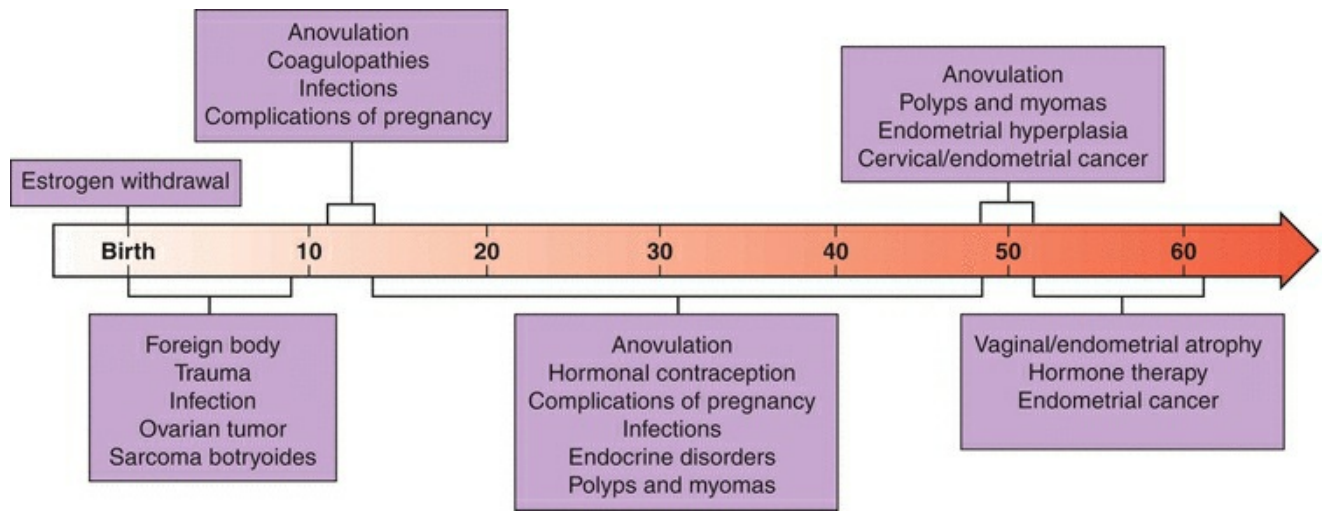
## AUB-N (Not Otherwise Classified)

This remains the vaguest category of the new classification system. Chronic endometritis can be placed under this heading given that the exact mechanism contributing to nor clinical implications of this histologic entity are entirely clear. Chronic endometritis is a histologic diagnosis, based on the finding of plasma cells in the endometrial stroma. The condition can result from infections (chlamydia, tuberculosis, mycoplasma), intrauterine foreign bodies or growths (IUD, submucous myoma), and radiation exposure, but no cause can be identified in about one-third of cases.<sup>109</sup> **Women with symptomatic chronic endometritis typically present with AUB, which can vary from intermenstrual spotting and postcoital bleeding to heavy menstrual bleeding.** Some may have vague, crampy lower abdominal pain, although many or most have no symptoms at all.

Chronic endometritis is seldom the direct cause but often may be an indirect or contributing cause of abnormal bleeding. Inflammatory cells release proteolytic enzymes that damage the subepithelial capillary plexus and surface epithelium, rendering them fragile and prone to breaks and microerosions. Proteases also interfere with both repair processes and new vessel formation. In addition, leukocytes and macrophages release platelet-activating factor and prostaglandins, which are potent vasodilators. Histologic studies suggest that chronic endometritis also contributes to abnormal bleeding relating to submucous and deep intramural myomas and endometrial polyps.<sup>77</sup>

Abnormal bleeding associated with arteriovenous malformations can also be categorized in this section.<sup>110</sup>

**Although the effort by FIGO to simplify and standardize the terminology used to describe menstrual abnormalities is reasoned and laudable, the adoption of this new nomenclature has been slow because the traditional terms, however ambiguous, still remain entrenched (Figure 15.6).**



**FIGURE 15.6**

# DIAGNOSTIC EVALUATION OF ABNORMAL UTERINE BLEEDING

---

A careful history and physical examination narrow the number of possibilities meriting serious consideration and define the scope and content of the evaluation required to establish a definitive diagnosis.

The history should seek to define each of the following characteristics:

- **Onset of abnormal menses (perimenarcheal, sudden, gradual)**
- **Duration (normal or prolonged, consistent or variable)**
- **Intermenstrual interval (number of days, regularity)**
- **Volume (heavy, light, or variable)**
- **Temporal associations (postcoital, postpartum, postpill, weight gain or loss)**
- **Associated symptoms (premenstrual molimina, dysmenorrhea, dyspareunia, galactorrhea, hirsutism)**
- **Underlying systemic illness (renal, hepatic, hematopoietic, thyroid)**
- **Medications (hormones, anticoagulants, antipsychotics, antidepressants, antiseizure)**

**In the majority of women with true anovulatory bleeding, the menstrual history alone can establish the diagnosis with sufficient confidence that treatment can begin without extensive laboratory evaluation or expensive imaging.** Infrequent, irregular, unpredictable menstrual bleeding that varies in amount, duration, and character and is not preceded by any recognizable or consistent pattern of premenstrual molimina or accompanied by any visible or palpable genital tract abnormality is not difficult to interpret. **Conversely, regular monthly periods that are heavy or prolonged are more likely related to an anatomical lesion or a bleeding disorder than to anovulation.** Objective methods for measuring menstrual blood loss include the photometric alkaline hematin test (the historical gold standard for research purposes but clinically impractical)<sup>111,112</sup> and menstrual pictograms (illustrations of blood stains of different sizes on feminine hygiene products),<sup>113,114</sup> both of which provide objective means of quantifying menstrual blood loss.<sup>115</sup> However, the most practical approach is the menstrual history. Although subjective, a history of changing pads or tampons more often than every 3 hours, use of more than 20 over single menses, the need to change protection during the night, frequent episodes of accidental soiling of clothing and bedsheets, the passage of clots larger than an inch in diameter, menses lasting longer than 7 days, and diagnosis of anemia should all raise concerns about abnormally heavy menstrual bleeding.<sup>30</sup> **Regardless of the actual amount of blood loss, menstrual**



**bleeding that interferes with daily activities or causes anxiety and concern merits evaluation.**

During the physical examination, attention should be given to the general well-being of the patient. Clinicians must be vigilant for signs that could reflect an underlying disorder as a cause of ovulatory dysfunction, such as signs of hyperandrogenism (discussed in [Chapter 11](#)), or features suggesting thyroid disorder (discussed in [Chapter 20](#)), or prolactin excess ([Chapter 4](#)). Gynecologic examination should systematically evaluate for potential anatomical contributors to AUB. Extrauterine sources for abnormal bleeding include the urethra (urethritis or caruncle), bladder (urinary tract infections and cancers), vagina (vaginitis, trauma, and ulcerative lesions), cervix (ectropion, cervicitis, polyps, focal lesions), vulva (trauma, skin lesions), and anorectal region (anal fissures, hemorrhoids, inflammatory bowel disease, cancers). During pelvic examination, attention should be paid to uterine size (normal or enlarged), contour (smooth and symmetrical or irregular), consistency (firm or soft), mobility and tenderness, and presence of adnexal masses.

# Laboratory Evaluation

Laboratory tests can be very helpful but are not always necessary. A sensitive urine or serum **pregnancy test** can quickly exclude the possibility that abnormal bleeding relates to a complication of pregnancy; a positive test leaves only a few diagnostic possibilities, which generally are not difficult to distinguish. A **complete blood count** to exclude anemia and thrombocytopenia is prudent in all women with complaints of abnormal bleeding. Iron studies should be considered especially when bleeding is heavy.

After excluding pregnancy, the most important question to answer is whether the patient is ovulating, because the causes and clinical management of ovulatory and anovulatory uterine bleeding are quite different. When the menstrual history alone does not allow a confident conclusion, a well-timed **serum progesterone** assessment during the putative luteal phase of the cycle can help to document ovulation or anovulation. A logical strategy is to obtain the test between cycle day 22 and 24 in women reporting a 28-day cycle, after ovulation in the longest normal cycle and before the end of the shortest normal cycle; any value greater than 3 ng/mL provides reliable evidence that ovulation has occurred recently.<sup>116</sup> However, when bleeding episodes are frequent or poorly documented, proper timing for a progesterone measurement can be difficult to determine. It also is important to remember that many women with abnormal bleeding, especially perimenarcheal and perimenopausal women, ovulate at least occasionally. Although most commonly applied to assess ovulatory function in women with infertility (and now seldom used even for that purpose), basal body temperature recordings can be quite informative in women with a confusing pattern of bleeding. Attainment of a dominant ovarian follicle can be followed and evidence of rupture ascertained by serial pelvic ultrasound imaging. Endometrial biopsy also can be used to assess ovulatory function (by identifying proliferative vs. secretory endometrium) but cannot be justified for that purpose alone when a less costly and less invasive serum progesterone measurement provides the same qualitative information. Thus, endometrial sampling should be reserved for those at risk for endometrial pathology, such as hyperplasia or neoplasia, as discussed below.

In sexually active women, a nucleic acid–based test for **chlamydia and gonorrhea** and a **wet prep** to exclude trichomonas infection merit consideration, particularly in those with evidence of vaginitis and/or cervicitis. In presumed or proven anovulatory women, a **serum thyroid-stimulating hormone (TSH)** level evaluates for an associated thyroid disorder, and prolactin level should be similarly checked to assess for hyperprolactinemia. **Liver or renal function tests** are indicated only for those with known or strongly suspected disease.

Adolescents, women with a suspicious personal or family history of bleeding symptoms (such as easy bruising, frequent gum bleeding when flossing or brushing teeth, epistaxis), and women with unexplained and protracted history of heavy menses warrant evaluation with **coagulation studies** to exclude coagulopathies, such as von Willebrand disease, factor deficiencies, and platelet function abnormalities.<sup>95,97,117,118</sup> **In addition to a platelet count, screening should include both a prothrombin (PT), which evaluates the extrinsic and final common clotting pathways, and an activated partial thromboplastin time (aPTT), which tests the intrinsic and common pathways of coagulation.** Although the PT and aPTT have relatively low positive and negative predictive value for detecting underlying bleeding disorders,<sup>119</sup> they are adequate screens for severe factor deficiencies.<sup>120</sup> **The high prevalence of von Willebrand disease among women with AUB (approximately 13%) warrants specific exclusion of the diagnosis and justifies measurement of von Willebrand factor, ristocetin cofactor activity (von Willebrand factor activity), the factor VIII level, and blood typing.**<sup>99,118,121</sup> It is important to note that test results can fluctuate over time<sup>122</sup> and also may vary across the menstrual cycle; repeated testing, ideally during the first few days of the cycle, may be required to establish the diagnosis of von Willebrand disease.<sup>99,123</sup> The blood type is helpful because von Willebrand factor and factor VIII levels are 25% lower in patients with type O blood than in those with other blood types.<sup>124</sup> For patients with abnormal coagulation studies, consultation with a hematologist is recommended.<sup>100,125</sup>

# Endometrial Sampling

An endometrial biopsy can exclude endometrial hyperplasia or cancer. Age over 35 or 40 years is widely considered a risk factor for endometrial disease and cited as an indication for biopsy in women with abnormal bleeding. **Endometrial hyperplasia and cancer are more commonly detected in older than in younger women, but the duration of exposure to unopposed estrogen stimulation is the more critical risk factor.** Long-term exposure is more likely in older than in younger women, but women under age 30, and even teenagers, can develop endometrial cancer.<sup>126,127,128,129</sup> In premenopausal women, the likelihood of abnormal endometrial histology is relatively high (14%) when menses are irregular but very low (<1%) when cycles are regular.<sup>130</sup> Thus, the prolonged unopposed estrogen exposure seen in obesity or anovulatory conditions like PCOS also merits endometrial sampling. Such sampling should also be pursued in a woman of any age who has persistent AUB despite reasonable attempts of medical management.

The small flexible suction cannulas now widely available (e.g., Pipelle suction curette) for endometrial biopsy cause less discomfort than older traditional biopsy instruments and yield comparable results.<sup>131,132,133</sup> Unfortunately, hospital-based curettage without hysteroscopy is still commonly performed, even though it is no longer the gold standard. Current indications for dilation and curettage (D&C) include a nondiagnostic office biopsy (for instance, in the setting of insufficient tissue for diagnosis or persistent AUB despite normal histology) or when the office biopsy cannot be completed, due to such factors as cervical stenosis or patient discomfort. When D&C is pursued, however, it is recommended that hysteroscopy be done beforehand to obtain targeted biopsies, if needed; this is warranted because of the significant likelihood of missing focal pathology with a diagnostic D&C.

In addition to revealing any intrinsic endometrial disease, such as hyperplasia, adenocarcinoma, or chronic endometritis, biopsy can help to direct further evaluation or to guide the choice of treatment in women with a confusing history of abnormal bleeding. An inactive or atrophic endometrium identifies women unlikely to respond to progestational therapy. **In women with no recent exposure to exogenous progestins, a secretory endometrium provides reliable evidence of recent ovulation and signals the need to search for an anatomical cause.**

# Imaging

Pelvic ultrasonography, preferably utilizing a transvaginal approach, can provide reliable information about the size and location of any uterine fibroids and raise suspicion for endometrial pathology or even adenomyosis as mechanisms for abnormal bleeding.<sup>134,135</sup>

Ultrasonography may reveal an obvious intracavitary lesion or an abnormally thin or thick endometrium. A very thin endometrial “stripe” (<5 mm), similar to a biopsy that yields minimal tissue, suggests an attenuated or denuded endometrium that is best treated first with estrogen rather than with a progestin or an estrogen-progestin combination (discussed below). **In perimenopausal and postmenopausal women with abnormal bleeding, endometrial biopsy generally is considered unnecessary when the endometrial thickness is less than 4 mm because the risk of endometrial hyperplasia or cancer is remote.**<sup>136,137,138</sup> It seems logical to apply the same criterion for the same reason in premenopausal women with abnormal bleeding, although there is no substantial direct evidence to support the extrapolation. Otherwise, the decision to biopsy or not should be based primarily on clinical suspicion and risk factors rather than on ultrasonographic measurements of endometrial thickness. That does not mean that endometrial thickness has no bearing on the decision whether to perform a biopsy; a grossly increased endometrial thickness (>12 mm) increases the risk of disease and is an indication for sampling, even when clinical suspicion of pathology is otherwise low.<sup>139</sup> **In summary, we believe that biopsy is unnecessary when the endometrial thickness is less than 4 mm and that biopsy is indicated when the clinical history suggests long-term unopposed estrogen exposure even when the endometrial thickness is “normal” (5–12 mm).**

Sonohysterography utilizes introduction of sterile saline via a catheter into the uterine cavity, while transvaginal ultrasound is being performed (the procedure is also known as hydrosalpingography and saline infusion sonography). The saline sharply defines the uterine cavity contours and readily demonstrates even small intrauterine lesions. The sensitivity and specificity of sonohysterography exceed that of standard transvaginal ultrasonography and compare favorably with hysteroscopy.<sup>76,140,141,142</sup> **The combination of sonohysterography and endometrial biopsy offers a high sensitivity and high negative predictive value for detection of endometrial and uterine pathology in women with abnormal bleeding.**<sup>143</sup> One disadvantage of the technique is that minor cavity contour abnormalities or blood clots may be misinterpreted as polyps; in this case, hysteroscopy and/or tissue sampling is often needed to clarify the true nature of the structural finding.

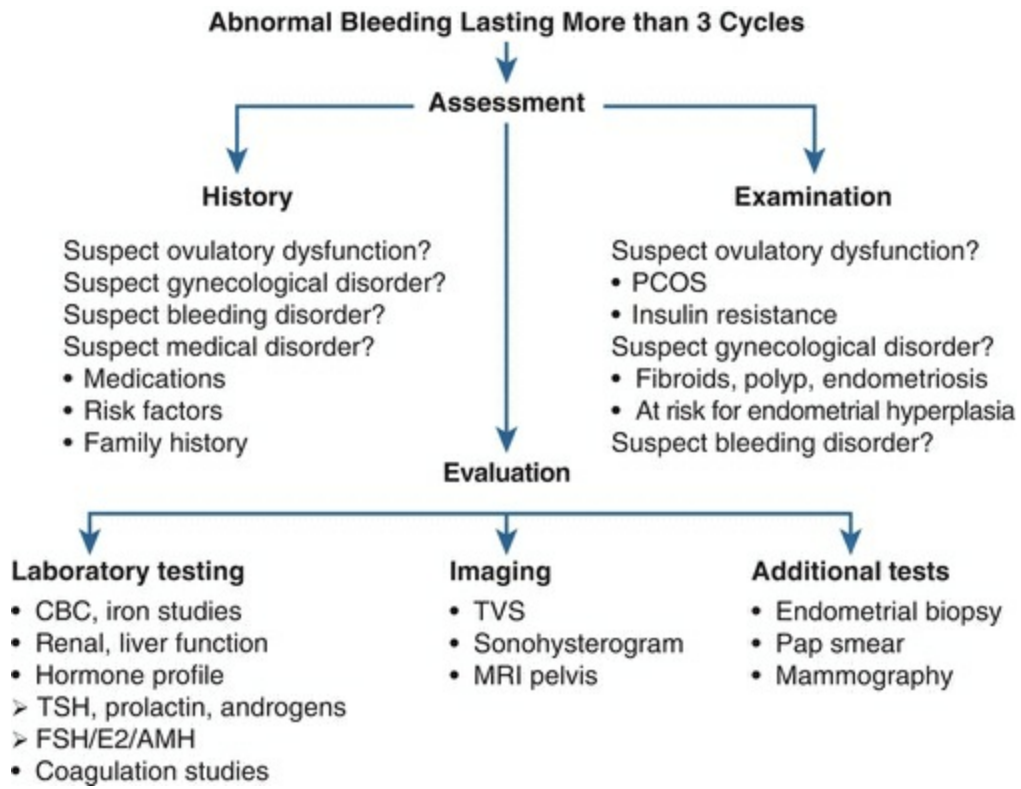
**Magnetic resonance imaging** is gaining acceptance in the evaluation of AUB. It

can reliably define uterine anatomy, distinguish between adenomyosis and leiomyomata, and demonstrate the proximity of myomas to the uterine cavity.<sup>144</sup> Although costly, MRI can be helpful in women who cannot be imaged adequately with ultrasonography or when surgical planning is needed.

**Hysteroscopy** is the definitive method for both diagnosis and treatment of symptomatic intrauterine pathology, particularly submucosal myomas and endometrial polyps; additionally, with technologic advances and better magnification, classic hysteroscopic findings attributable to adenomyosis and chronic endometritis are also recognized.<sup>75,145</sup> Traditionally, hysteroscopy has been reserved for treatment of disease identified by other less invasive methods, but modern hysteroscopes having an outer diameter of 2–5.5 mm now permit diagnostic and minor operative procedures to be performed in the office setting with minimal anesthesia.<sup>146</sup> For clinicians having the necessary training and experience, office hysteroscopy has a very low incidence of complications, which may include uterine perforation, infections, and excessive bleeding. Major intrauterine pathology generally requires more traditional operative hysteroscopy using instruments having a larger caliber and greater capabilities.

**In general, diagnostic uterine imaging can be reserved for women in whom the menstrual history or the results of other evaluations provide strong evidence for an anatomical cause of abnormal bleeding, including any of the following:**

- **Regular monthly cycles with increasing volume or duration of bleeding**
- **Regular monthly cycles complicated by intermenstrual bleeding in the absence of a vaginal or cervical lesion.**
- **Abnormal bleeding despite objective evidence of ovulation from measurement of serum progesterone (>3 ng/mL) or from endometrial sampling (secretory endometrium)**
- **Failed empirical medical management ([Figure 15.7](#))**



**FIGURE 15.7**

# MANAGING ABNORMAL UTERINE BLEEDING

---

As in all aspects of clinical medicine, the success of treatment hinges on an accurate diagnosis. When there is good reason to suspect a coagulopathy or uterine pathology as the cause of abnormal bleeding, diagnostic laboratory tests, endometrial biopsy, or uterine imaging should be considered carefully before beginning empiric medical management. **However, when there is every reason to believe that anovulation is the cause, empiric medical management based on that premise is entirely reasonable; a prompt resolution of the problem also should be expected. When bleeding persists despite appropriate empiric medical management, further diagnostic evaluation is more productive than a higher dose or otherwise different medical treatment regimen.**



# TREATMENT OF ANOVULATORY BLEEDING

---

The primary objective of treatment in women with anovulatory bleeding is to induce or restore the natural control mechanisms that are not operating—orderly, synchronous growth, development, and shedding of a structurally stable endometrium. Without treatment or correction of the cause of chronic anovulation, recurrent episodes of heavy or prolonged bleeding can be expected.

Although most women with anovulatory bleeding can be managed effectively on an outpatient basis, acute bleeding occasionally may be severe enough to require hospitalization and emergency treatment. **Hospitalization is indicated for women with active hemorrhage who are hemodynamically unstable and those with symptomatic anemia or a serious underlying medical illness.** The most effective initial strategy in emergent circumstances is to insert a Foley catheter with a 30-mL balloon into the uterus to **tamponade** the bleeding while establishing intravenous access for fluid administration and, if necessary, transfusion.<sup>147</sup> Once the patient is stabilized, the diagnostic evaluation can proceed to determine the cause of the bleeding and the most appropriate treatment strategy. Acute anovulatory bleeding can be treated with estrogen, estrogen-progestin, or progestin alone. The best choice in a given patient depends primarily on the condition of the endometrium at the time. **It is important to emphasize that progestin treatment (remembering that the net effect of all estrogen-progestin contraceptives is progestational) is unlikely to be effective in patients with a thin, attenuated, or denuded endometrium.** Ideally, given the importance of making the correct choice in women with acute bleeding, transvaginal ultrasonography should be performed before treatment begins, to identify any obvious pathology that may dictate management and to assess the endometrial thickness.<sup>134</sup> **Possibility of pregnancy complications must be excluded in any patient presenting with AUB.**

# Progestin Therapy

Just as progesterone is the dominant and controlling influence in normal menstrual cycles, progestins are the mainstay of treatment for anovulatory bleeding. Progestins are powerful antiestrogens. Progestins stimulate  $17\beta$ -hydroxysteroid dehydrogenase and sulfotransferase activity, the enzymes that work in concert to convert estradiol to estrone sulfate (which is rapidly cleared from the body).<sup>148</sup> Progestins further antagonize estrogen action by inhibiting estrogen's induction of its own receptor (estrogen receptor replenishment). Progestins also suppress estrogen-mediated transcription of oncogenes.<sup>149</sup> Together, these actions explain the antimitotic, growth-limiting effects of progesterone and progestins on the endometrium (arrest of growth during the secretory phase of the cycle, prevention and reversal of hyperplasia, and marked attenuation during pregnancy or treatment with estrogen-progestin contraceptives).

In most circumstances, progestin therapy will control anovulatory bleeding once uterine pathology has been excluded. **In oligomenorrheic anovulatory women with episodic abnormal bleeding, orderly, predictable, self-limited progestogen withdrawal bleeding can be induced by cyclic treatment with an orally active progestin (e.g., medroxyprogesterone acetate 5–10 mg daily for 10–14 days each month).** Cyclic progestin therapy restores the normal sequence of endometrial steroid hormone stimulation—estrogen, followed by estrogen plus progestogen, followed by withdrawal. The interval of progestin therapy can be fixed to the calendar (beginning on the first of every month) or to the timing of menses (beginning 15–16 days after onset of the last progestin-induced menses); both regimens work well. **Failed progestin treatment suggests strongly that another pathology is causing or contributing to the problem and signals the need for additional diagnostic evaluation.**

**Although cyclic progestin therapy generally works well in women who are completely anovulatory and not sexually active, treatment with an estrogen-progestin contraceptive is a better choice for those who likely still ovulate (albeit infrequently) or want to avoid pregnancy.** Inevitably, programmed cyclic progestin treatment will not coincide with endogenous progesterone production in random ovulatory cycles like those that occur in aging women. When that happens, bleeding may deviate from the predicted pattern and be misinterpreted or cause alarm. **Moreover, standard cyclic progestin treatment regimens do not reliably suppress the HPO axis, so they will not prevent random ovulation and are not contraceptive.** In contrast, contraceptive doses of exogenous steroids effectively suppress endogenous function and prevent such confusion.

Acute severe anovulatory bleeding also can be treated effectively with high-dose progestin alone (medroxyprogesterone acetate 10–20 mg twice daily, megestrol acetate

20–40 mg twice daily, norethindrone 5 mg twice daily), provided that the endometrial thickness on ultrasound is in normal range or is thickened, suggestive of some degree of target tissue estrogen exposure.<sup>150,151,152</sup> Once initiated, progestin treatment should continue for approximately 3 weeks, decreasing frequency of dosing to once daily treatment after 7–10 days. High-dose progestin treatment induces stabilizing predecidual changes in a thickened, vascular, and fragile endometrium. However, a substantial amount of tissue remains to be shed upon progestin withdrawal, resulting in a so-called medical curettage. **If not warned to expect heavy menses and increased dysmenorrhea likely to arrive within 2–4 days after progestin treatment stops, most women will interpret this heavy bleeding experience as “treatment failure.”** Thereafter, standard cyclic progestin treatment or an estrogen-progestin contraceptive may be offered for longer-term management.

Depot-medroxyprogesterone acetate (150 mg intramuscularly every 3 months) can be a useful option for maintenance therapy in women who have difficulty with or cannot take estrogen-progestin contraceptives. **However, depot progestin treatment has no place in the acute management of abnormal bleeding. Once given, it cannot be withdrawn, and resulting intolerable side effects can be difficult to overcome.** Episodic breakthrough bleeding is relatively common and can be treated with estrogen as discussed below.

The levonorgestrel-releasing intrauterine system (LNG-IUS) is an effective progestin-based strategy for the long-term management of anovulatory bleeding in women who do not actively desire pregnancy. Beyond the first few months following insertion of a LNG-IUS during which time irregular spotting is not uncommon, almost two-thirds of users develop scant to absent menses. LNG-IUS is an ideal approach for managing AUB in women deemed at risk for endometrial pathology (such as those with chronic anovulation and who are obese), in those experiencing poor tolerance of systemic progestin regimens, and in those in whom estrogen use may be contraindicated.<sup>153</sup>

# Estrogen-Progestin Therapy

**Women with anovulatory bleeding who are sexually active and not planning on pursuing pregnancy are often effectively managed by treatment with an estrogen-progestin contraceptive.** A gradual but progressive decrease in the volume and duration of flow and improvement in associated dysmenorrhea can be expected and are reassuring. In women with normal uteri, estrogen-progestin contraceptives reduce menstrual flow by at least 60% from that in natural cycles.<sup>154</sup> Longer cycle regimens (discussed in [Chapter 22](#)) offer the advantage of fewer and lighter menses but increase the incidence of episodic breakthrough bleeding.

**Acute prolonged episodes of heavy anovulatory bleeding also can be treated effectively with high-dose estrogen-progestin therapy, provided that the endometrium is or normal or increased thickness.** Ideally, transvaginal ultrasonography should be performed before treatment begins to minimize the risk of unsuccessful treatment with continued heavy blood loss, as will occur in women with a denuded endometrium when either progestin alone or a low estrogen dose combined hormone regimen is chosen for managing heavy bleeding. In women with a thickened, vascular, and fragile endometrium, estrogen-progestin treatment inhibits further growth and induces structural changes that organize and stabilize the endometrium, thereby preventing further random breakdown. **Any monophasic combination oral contraceptive can be used in a multidose regimen as first-line approach to managing heavy abnormal bleeding in hemodynamically stable individuals** ([Table 15.4](#)).<sup>155,156,157</sup>

## **TABLE 15.4 High-Dose Oral Contraceptive Regimens for Control of Heavy Abnormal Bleeding**

Ethinyl Estradiol Dose in Combined Oral Contraceptive	Regimen	Anticipated effect
30–35 µg	1 pill 3 times daily × 48–72 h 2 pills daily × 1 wk 1 pill daily × 1 wk Stop Consider restarting at 1 pill daily	Reduction anticipated within 48 h. If nausea, consider adding an antiemetic Withdrawal bleeding Cycle control
20–25 µg	1 pill 4 times daily 3 pills daily × 1 wk 2 pills daily × 1 wk 1 pill daily × 1 wk Stop Consider restarting at 1 pill daily	Reduction anticipated within 48 h. If nausea, consider adding an antiemetic Withdrawal bleeding Cycle control
30–35 µg	1 pill <ul style="list-style-type: none"> <li>• 4 times daily × 4 d</li> <li>• 3 times daily × 3 d</li> <li>• 2 times daily × 2 d</li> <li>• 1 tablet daily × 3 wk</li> </ul>	Reduction anticipated within 48 h. If nausea, consider adding an antiemetic
30–35 µg	Day#1—5 pills Day#2—4 pills Day#3—3 pills Day#4—2 pills Days#5 to days 14–21—1 pill daily Stop Consider restarting at 1 pill daily	Reduction anticipated within 48 h. If nausea, consider adding an antiemetic Withdrawal bleeding Cycle control

Data from Ely JW, Kennedy CM, Clark EC, Bowdler NC, Abnormal uterine bleeding: a management algorithm, J Am Board Fam Med 19(6):590, 2006.

**The dose of ethinyl estradiol in the contraceptive regimen should be considered when deciding on the multidose regimens as higher starting number of pills should be considered for pills containing 20–25 µg or lesser doses of ethinyl estradiol. These regimens achieve reduction in bleeding within 24–40 hours in most women. Once control of bleeding is achieved, a taper in hormone dosing should be planned over the next 1–2 weeks with the goal of continuing one pill daily for at least 1 week after the bleeding completely subsides. Patient should be informed that stopping the hormone regimen will be followed by withdrawal bleeding, following which starting a standard dose of oral contraceptives can be considered to prevent future episodes of abnormal bleeding and to allow the opportunity for hemoglobin levels to increase in anemic patients. Failed estrogen-progestin treatment indicates the need for additional diagnostic evaluation.**

# Estrogen Therapy

Intermittent vaginal spotting frequently is associated with marginal or frankly low levels of estrogen stimulation (estrogen breakthrough bleeding) and a very thin, unstable endometrium. In this setting, the usual beneficial effect of progestin treatment cannot be achieved because estrogen levels are insufficient to stimulate the growth that serves as the foundation for the actions of progestin; the growth-limiting effects of progestin are not helpful and may further aggravate the problem, as in women whose endometrium becomes denuded after prolonged heavy bleeding. Logically, estrogen therapy is the most effective initial treatment strategy.

Estrogen also is the obvious and best choice for management of episodic progestogen breakthrough bleeding, as commonly observed in women receiving low-dose estrogen-progestin contraceptives, depot medroxyprogesterone acetate, or other forms of continuous progestin treatment utilized for contraception (e.g., the progestin-only “minipill” or progestin implants) or in the management of endometriosis.<sup>158</sup> A common clinical story involves long-term use of estrogen-progestin contraception with reports of markedly decreased or absent menstrual flow during the pill-free week and episodes of breakthrough bleeding at other times. Over time, unless there is sufficient endogenous or exogenous estrogen to effectively balance its effects, progestin attenuates the endometrium, inducing pseudoatrophy. Histologically, the endometrium has little height and is composed almost entirely of pseudodecidualized stroma and blood vessels with relatively few glands. Although the mechanism is different, the light spotting, staining, or bleeding that may occur is in many ways similar to the type of estrogen breakthrough bleeding observed in women with marginal or very low levels of circulating estrogen. In all such scenarios, a short interval of added estrogen (e.g., conjugated estrogens 1.25 mg or micronized estradiol 2.0 mg daily for 7–10 days) is generally highly effective. In some women, the problem recurs frequently or persists. Higher doses, longer durations, or repeated courses of estrogen treatment are sometimes needed. When treatment fails, further evaluation with transvaginal ultrasound or sonohysterography can exclude the possibility of a previously unrecognized endometrial polyp or submucous myoma. Rarely, only a brief hiatus in estrogen-progestin or progestin alone treatment will resolve the problem.

**When acute, heavy bleeding results in a thin, denuded endometrium, high-dose estrogen therapy is the best initial treatment; progestin or estrogen-progestin therapy is unlikely to succeed and may aggravate the problem.** Estrogen stimulates endometrial re-epithelialization and proliferation and stabilizes lysosomal enzymes. Evidence suggests that high-dose estrogen therapy also stimulates clotting at the capillary level.<sup>159,160</sup> **In patients who are hemodynamically unstable, intravenous estrogen therapy (25 mg conjugated equine estrogens every 4 hours intravenously**

**until bleeding subsides, for up to 24 hours) is very effective.** Treatment with an antiemetic is recommended (e.g., promethazine, 12.5–25 mg intramuscularly or rectally), because high-dose estrogen results in nausea and vomiting in up to 40% of patients.<sup>161</sup> The regimen controls acute bleeding effectively in more than 70% of patients, usually within 4–8 hours.<sup>161</sup> Thereafter, high-dose estrogen therapy should continue orally (2.5 mg conjugated estrogens or 2.0 mg micronized estradiol every 6 hours), tapering to a once daily dose after bleeding is controlled and adding a progestin (e.g., medroxyprogesterone acetate 5–10 mg daily × 7–10 days) or changing to an estrogen-progestin contraceptive after 14–21 days to stabilize the estrogen-stimulated endometrial growth. In the hemodynamically stable patient with a denuded endometrium whose bleeding is less emergent but still acute and quite heavy, the same high-dose oral estrogen and antiemetic treatment regimen generally is effective.

**High-dose intravenous or oral estrogen treatment may increase the risk of thromboembolism. There are no data that quantify the risk, but venous and pulmonary embolism is a potential complication and has been reported.<sup>162</sup> As with any therapeutic decision, the benefits of treatment must be weighed against its potential risks and those of alternative methods for the management of AUB. In women with a personal or family history of thromboembolism, high-dose estrogen treatment should be avoided, if at all possible.**

# Curettage

In women with acute bleeding, **dilation and curettage** can be performed as both a therapeutic and diagnostic procedure. Curettage is an expeditious and effective way to stop acute uncontrollable uterine bleeding in the absence of any apparent pathology.<sup>163</sup> The mechanism responsible for the therapeutic effects of curettage is not entirely clear, but surgical denudation of the basal layer of the endometrium is presumed to acutely stimulate all of the normal processes involved in cessation of normal menstrual bleeding—local clotting mechanisms, vasoconstriction of basal arterioles, and re-epithelialization.<sup>39</sup> Blind curettage however can easily miss focal lesions and, in most cases, does not treat the underlying cause of bleeding.<sup>164</sup> Consequently, curettage ideally should be combined with hysteroscopy to improve diagnostic accuracy and the effectiveness of postoperative treatment, thereby minimizing the risk for recurrence.<sup>26,147</sup>



# TREATMENT OF ABNORMAL BLEEDING FROM SPECIFIC CAUSES

---

As reviewed above, not all irregular or abnormally heavy or prolonged menstrual bleeding relates to anovulation. History and physical examination generally are all that is needed to exclude trauma and foreign bodies. With few exceptions (retained nonviable products of conception), complications of pregnancy are easily excluded with a simple pregnancy test. Cervical biopsy of any suspicious lesion and endometrial biopsy in women with risk factors for endometrial cancer eliminate reproductive tract malignancies as a possibility. Otherwise, the differential diagnosis of abnormal bleeding in ovulatory women and in anovulatory women who fail appropriate hormonal treatment centers on a few major possibilities that are captured by the PALM-COEIN mnemonic and which require an individualized management approach.

# Endometrial Polyps

**When polyps are identified by transvaginal ultrasonography or sonohysterography, hysteroscopic surgery offers a simple and highly effective remedy.<sup>39</sup>** In premenopausal women, endometrial polyps have only a 1.7% chance of malignancy, but the risk is increased if the patient has AUB. Thus, for patients with AUB-P, polyp removal is recommended to both address the presenting symptom and assess for malignancy.

# Adenomyosis

Symptomatic adenomyosis can be particularly challenging. There have been no large or controlled studies of medical or limited surgical treatment for adenomyosis. In individual patients, continuous treatment with progestins, suppression by treatment with a GnRH agonist, and use of aromatase inhibitors can be effective, similar to their use in patients with endometriosis.<sup>165</sup> **Growing evidence indicates that insertion of a LNG-IUS can be very effective in providing relief from both menorrhagia and dysmenorrhea in women with adenomyosis.**<sup>166,167,168,169,170</sup> Conservative surgery can be technically challenging because, unlike the pseudocapsule that typically surrounds leiomyomas, there is no clear plane separating adenomyotic nodules from normal myometrium. Uterine artery embolization has proven effective in some women but is not appropriate for women who have not completed childbearing.<sup>171,172,173</sup>

# Leiomyomas

The nature and severity of symptoms; the size, location, and multiplicity of myomas; and desire for fertility are all relevant to the choice of management approach to symptomatic uterine myomas. In some women, medical treatment can be helpful in the management of abnormal bleeding directly related to uterine myomas. Estrogen-progestin contraceptives can decrease the volume and duration of blood loss in the same way they do in women without fibroids; benefits are less likely in women with submucous myomas. Nonsteroidal anti-inflammatory drugs (NSAIDs), GnRH agonists, and, most recently, GnRH antagonists all offer benefits and are individually discussed below.

**The surgical management of abnormal bleeding resulting from or aggravated by uterine myomas must be individualized after considering the size, number, and location of the fibroids; the relative risks, benefits, and consequences of different surgical treatments; age; and desire for future fertility.** In general, hysteroscopic myomectomy is a logical choice for a single symptomatic small submucous myoma, regardless of age and future reproductive goals. Hysteroscopic surgery for large and multiple submucous myomas requires greater technical expertise and poses greater risks, including sterility resulting from severe postoperative intrauterine adhesions—an important consideration in women who hope to preserve their fertility. Patients should be counseled that a hysteroscopic approach for resection of a large or numerous submucosal fibroids may require a staged or “two-step” surgery, if visibility is compromised due to poor distention of the cavity or attainment of maximal fluid deficit before complete resection is achieved. Submucous myomas that extend deeply into the myometrium (>50%) can be managed by subtotal hysteroscopic myomectomy, abdominal myomectomy, or hysterectomy, depending on the surgeon’s skills and the need to preserve fertility potential. For those experienced with the procedure, laparoscopic or robotic myomectomy approaches are options that are increasingly utilized by women who have not yet completed childbearing; while offering quicker postoperative recovery and cosmetic benefits from smaller size incisions, these minimally invasive approaches do not eliminate the risk of pelvic adhesions nor the need for cesarean delivery in a future pregnancy. Hysterectomy is certainly an option for women with AUB, multiple large fibroids, and no interest in future pregnancy.

# Endometrial Hyperplasia

Endometrial hyperplasia is a histologic diagnosis based on findings of proliferating glands of varying size and shape and a greater gland-to-stroma ratio than is observed in the normal endometrium.<sup>79</sup> Endometrial hyperplasia results almost exclusively from unopposed chronic estrogen stimulation.

Historically, endometrial hyperplasia was classified as simple or complex (reflecting the architectural pattern), with or without nuclear atypia (enlargement, rounding, pleomorphism, and aneuploidy). The simple and complex designations, based upon the gland-to-stroma ratio in the endometrium, were abandoned by the World Health Organization in 2014,<sup>80</sup> both to simplify the terminology and to better reflect the molecular understanding that only the presence of atypia is reflective of the genetic changes that are relevant to the risk of progression of hyperplasia to invasive endometrial cancer. Lesions without atypia basically represent only exaggerated forms of persistent proliferative endometrium; they regress spontaneously, after curettage or with progestin treatment, and are associated with little risk (1–3%) for progression to adenocarcinoma.<sup>81,82,83,84</sup> In contrast, atypical endometrial hyperplasia exhibits an entirely different behavior; it does not often spontaneously regress, can be quite resistant to even repeated curettage or prolonged high-dose progestational therapy, has significant risk (10–30%) of progression to adenocarcinoma if left untreated, and must therefore be regarded as a precancerous lesion.<sup>81,82,83,84</sup> Atypical lesions are distinguished from invasive carcinomas by the absence of stromal invasion. It is important to note that, despite concerted efforts to standardize classification criteria, there is significant interobserver variability in the classification assigned by pathologists, even within the same institution.<sup>85,86</sup> Other classification systems have been proposed,<sup>87,88</sup> but none has gained wide acceptance.

**When an office biopsy reveals endometrial hyperplasia, further evaluation is required to exclude atypia or a coexisting cancer that was not represented in the tissue specimen, and if subsequent curettage reveals atypical endometrial hyperplasia, there is significant risk of an unrecognized adenocarcinoma.** In a retrospective study involving 824 women with a diagnosis of complex atypical hyperplasia after office sampling, 100 were diagnosed with cancer after further evaluation with curettage, but 298 of the remaining 724 (41%) had unexpected cancer in a hysterectomy specimen obtained within 6 months of the original diagnosis; among those having an occult cancer, 30% had been further evaluated with curettage and 45% had not.<sup>89</sup>

Endometrial hyperplasia without atypia has a low risk for progression to endometrial cancer and can be corrected using progestin treatment regimens similar to

those recommended for the management of anovulatory bleeding. Cyclic progestin therapy (medroxyprogesterone acetate 5–10 mg daily or norethindrone acetate 5 mg daily for 14 days/month × 3–6 months) induces regression in at least 80–90% of patients<sup>82,174</sup>; alternatively, continuous progestin treatment for a similar interval is an effective option. Yet another option for women interested in longer-term contraception is LNG-IUS.<sup>175,176,177</sup> Repeat biopsy to confirm regression is recommended in 3 months following initiation of treatment, and in those with a LNG-IUS, it can be performed without removing the device.

**Hysterectomy should be considered in patients with persistent endometrial hyperplasia with atypia that is unresponsive to aggressive progestin regimens.** Women with intent on preserving their reproductive potential may be treated with progestins, but more potent and longer durations of treatment (megestrol acetate 80 mg twice daily for 3–6 months) are required and repeated biopsies to monitor response and confirm resolution of the lesion are essential. Insertion of an LNG-IUS is an effective treatment option<sup>178</sup>; in fact, multiple studies suggest it is more effective than oral progestins, with higher resolution and lower relapse rates. Most women with atypical hyperplasia will respond to medical treatment.<sup>179,180,181</sup> The median time to regression is approximately 9 months, and persistent disease after 7–9 months of treatment predicts failure.<sup>179,181</sup> Resistant lesions in women who remain adamantly opposed to surgery may require even higher and longer durations of progestational therapy. The resistance of atypical lesions to progestin therapy should not be surprising since nuclear atypia reflects a degree of cellular dedifferentiation. **Women who respond to medical management should be encouraged to pursue pregnancy at the earliest possible time and must be carefully monitored because recurrence is common. Once childbearing is completed, placement of LNG-IUS and periodic endometrial surveillance utilizing transvaginal ultrasound and endometrial sampling may be considered.**

# Coagulation Disorders

Desmopressin (DDAVP) is a synthetic analog of arginine vasopressin that has been used to treat AUB in women with coagulation disorders, especially those with von Willebrand disease.<sup>182,183,184</sup> The drug promotes the release of von Willebrand factor from endothelial cell storage sites and also may have other actions.<sup>185</sup> Desmopressin can be administered intravenously, subcutaneously, or by intranasal spray. The nasal spray formulation generally is recommended for home and prophylactic treatment of von Willebrand disease. Treatment induces a rapid increase in coagulation factor VIII and von Willebrand factor that lasts 6–12 hours. **Although its effects may be only modest, desmopressin has been used successfully in the management of heavy menstrual bleeding in women with von Willebrand disease, beginning treatment with the onset of menses.**<sup>183,184,186, 187,188</sup>

Antifibrinolytic therapy is an alternative to treatment with desmopressin in women with menorrhagia relating to von Willebrand disease. Tranexamic acid prevents clot dissolution, particularly in mucous membranes having naturally high fibrinolytic activity such as the endometrium.<sup>188,189</sup> Estrogen-progestin contraceptives or the LNG-IUS also help to reduce the volume and duration of menses in women with von Willebrand disease.<sup>190,191</sup>

# Chronic Endometritis

Although there is no single etiology that has been identified as a mechanism for chronic endometritis, a number of infectious etiologies have been suggested including gut bacteria, mycoplasma, ureaplasma, chlamydia, and even yeast. While there is no consensus on the choice of antimicrobial regimen nor on duration of therapy, a number of empiric regimens are in clinical use ([Table 15.5](#)).<sup>192,193,194,195</sup>

## **TABLE 15.5 Common Approaches to Managing Chronic Endometritis (CE) Chronic Endometritis**



Approach	Who for?	With what?	How long?
<b>Expectant</b>	If CE is an incidental finding	Vigilant Watching	—
<b>Antimicrobial treatment</b>	If evidence of CE is accompanied by: <ul style="list-style-type: none"> <li>• Abnormal bleeding</li> <li>• Pregnancy loss</li> <li>• Infertility</li> </ul>	<ol style="list-style-type: none"> <li>1. Doxycycline</li> <li>2. Metronidazole</li> <li>3. Levaquin</li> <li>4. Ciprofloxacin</li> <li>5. Combinations <ul style="list-style-type: none"> <li>• 1 + 2</li> <li>• 1 + 3 or 1 + 4</li> <li>• 1 + 2 + 3</li> </ul> </li> </ol>	7–21 d

If the abnormal bleeding does not improve with this treatment, efforts should be made to identify another explanation for the abnormal bleeding.

# OTHER TREATMENTS FOR HEAVY MENSTRUAL BLEEDING

---

A specific cause for heavy or prolonged menstrual bleeding in ovulatory women cannot always be identified; local defects in endometrial hemostasis are presumed responsible.<sup>196</sup> Nevertheless, the problem still can be effectively managed using a variety of nonspecific medical and surgical therapies.

# Nonsteroidal Anti-Inflammatory Drugs

There is little question that prostaglandins have important actions on the endometrial vasculature and in endometrial hemostasis. The concentrations of PGE<sub>2</sub> and PGF<sub>2α</sub> increase progressively in human endometrium during the menstrual cycle and are found in high concentrations in menstrual endometrium.<sup>39</sup> The NSAIDs inhibit prostaglandin synthesis and decrease menstrual blood loss and may also alter the balance between thromboxane A<sub>2</sub> (a vasoconstrictor and promoter of platelet aggregation) and prostacyclin (a vasodilator and inhibitor of platelet aggregation).<sup>197</sup>

Although the exact mechanism involved is unclear, NSAIDs decrease both normal menstrual bleeding and the increased bleeding associated with an intrauterine device.<sup>198,199</sup> **In general, NSAID treatment reduces menstrual blood loss by approximately 20–40% and to a greater extent in those with heavy menstrual bleeding.**<sup>200,201,202</sup> Ibuprofen (400 mg, taken 3 times daily) and mefenamic acid (500 mg, taken 3 times daily) have been studied most extensively, but no specific NSAID offers any clear advantage.<sup>202</sup> Treatment with NSAIDs might be considered the first-line therapy for ovulatory women with heavy menstrual bleeding and no demonstrable pathology. Side effects are few because treatment is limited, usually beginning with the onset of bleeding and continuing for 3–5 days as necessary. NSAIDs have the added advantage of providing relief from dysmenorrhea, even when menses are normal, and can be taken perimenstrually by women attempting to conceive.

# Estrogen-Progestin Contraceptives

In addition to their role in anovulatory women, estrogen-progestin contraceptives can be used to reduce menstrual blood loss in ovulatory women with heavy menstrual bleeding, regardless whether the bleeding is associated with pathology (e.g., myomas, adenomyosis) or is unexplained. **In women with unexplained menorrhagia, estrogen-progestin contraceptives can be expected to decrease bleeding by up to 40%.** <sup>203,204</sup>

# The Levonorgestrel-Releasing Intrauterine System

The LNG-IUS is available in multiple models with different doses and release rates of progestin, as well as different physical sizes and durations of efficacy. The best-studied model is LNg 52/5, marketed in the United States under the brand name Mirena. Mirena has a reservoir containing 52-mg levonorgestrel mixed with polydimethylsiloxane, which controls the rate of hormone release. For contraceptive purposes, the device is approved for 5 years but lasts for 7 years and perhaps up to 10 years. **Menstrual blood loss in women with heavy menstrual bleeding can be reduced by 75–95%, due to progestin-induced decidualization of the endometrium.**<sup>205,206</sup> Data from randomized trials indicate that the decrease in menstrual blood loss achieved with the LNg 52/5 is greater than with cyclic administration of norethindrone (5 mg 3 times daily, cycle days 5–26),<sup>206,207</sup> NSAIDs,<sup>208,209</sup> or tranexamic acid<sup>210</sup> and approaches or even equals that achieved with endometrial ablation.<sup>211,212</sup> Patient satisfaction with the LNG-IUS also compares favorably to that with ablation or hysterectomy.<sup>211</sup> **The LNG-IUS is an attractive option for ovulatory women with heavy menstrual bleeding and for women with intractable bleeding associated with chronic illnesses (renal failure).**

# Gonadotropin-Releasing Hormone Agonists

Treatment with a long-acting gonadotropin-releasing hormone agonist (GnRHa) can achieve short-term relief from a bleeding problem and has been used effectively as a preoperative adjunct in women awaiting conservative (myomectomy, endometrial ablation) or definitive surgery (hysterectomy) for abnormal bleeding.

**In women with severe anemia resulting from menorrhagia, preoperative GnRHa-induced amenorrhea can provide temporary relief from further bleeding, allow hemoglobin levels to return to normal, and decrease the probability of transfusion with surgery.** GnRHa treatment also will often decrease the size of myomas and overall uterine mass. In women with large fibroids awaiting hysterectomy, the effect can provide an added benefit by allowing a minimally invasive surgical approach when an abdominal operation might otherwise have been required. While the same benefit can be obtained for women with plans for myomectomy (along with a small decrease in intraoperative blood loss), GnRHa can decrease the size and firmness of myomas, making their identification and removal more difficult. This can result in both an increase in surgical difficulty and an increased chance of persistent myomas that remain after the surgery. As a method for thinning the endometrium before an ablation procedure (particularly using a resectoscope), GnRHa treatment improves operating conditions and outcomes.<sup>213</sup>

GnRHa treatment is also useful in the management of abnormal menstrual bleeding that may follow organ transplantation where the toxicity of immunosuppressive drugs makes use of sex steroids less desirable. However, the expense and side effects resulting from estrogen deficiency (hot flashes, bone mineral depletion) make GnRHa an unattractive long-term strategy for treatment of abnormal bleeding.

# **Gonadotropin-Releasing Hormone Antagonists**

An oral formulation of a GnRH antagonist was recently approved in the United States (Elagolix) for the management of moderate to severe pain associated with endometriosis but also offers a potential for benefit for the management of heavy uterine bleeding related to uterine fibroids.<sup>214</sup>

# Selective Progesterone Receptor Modulators

This class of agents includes mifepristone and ulipristal acetate (UPA), which in the past decade has emerged as an effective strategy against heavy menstrual bleeding related to uterine fibroids. Selective progesterone receptor modulators (SPRMs) are highly effective in improving fibroid-related menstrual loss and health-related quality of life.<sup>215</sup> In clinical studies, repeated doses of UPA reduced the median fibroid volume by 45% with nearly 90% of patients reporting a significant reduction in menstrual bleeding.<sup>216</sup> Long-term use of SPRMs however has been associated with unique endometrial effects described as progesterone receptor modulator–associated endometrial changes (PAEC), which are considered as both benign and reversible.<sup>217</sup>



# Tranexamic Acid

Tranexamic acid is an antifibrinolytic agent that has been used widely in Europe for the treatment of menorrhagia. The drug reversibly blocks lysine binding sites on plasminogen, thereby preventing fibrin degradation. An oral form of the drug was approved by the U.S. Food and Drug Administration in 2009 for the treatment of heavy menstrual bleeding. The drug is administered for 4–7 days during menses (1000–1500 mg 3–4 times daily; the FDA-approved formulation sold in the United States is taken as 1300 mg 3 times daily for 5 days during menstruation) and decreases menstrual blood loss by 35–60%.<sup>218,219</sup> The risk for thrombosis associated with tranexamic acid is controversial.<sup>220,221</sup> Consequently, it has limited value in women with contraindications to hormone therapy, because most relate to the risk of thrombosis.

# Endometrial Ablation

Persistent bleeding despite treatment is both frustrating and concerning. Myomas and polyps usually can be removed, with improvement or resolution of abnormal bleeding. Hysterectomy is an appropriate choice for some, but many prefer to avoid a major operation if possible, and still others have conditions that make them poor candidates for major surgery. Endometrial ablation is another option for the management of unexplained heavy menstrual bleeding when medical treatments are rejected, unsuccessful, or poorly tolerated.<sup>222</sup>

A wide variety of methods have been developed for endometrial ablation. The first method described was hysteroscopic Nd:YAG (neodymium-doped yttrium aluminum garnet) laser photovaporization, almost 40 years ago.<sup>223</sup> Soon thereafter, less costly techniques were developed using electro-surgical instruments (resectoscopic loop, roller ball).<sup>224,225</sup> A number of randomized controlled trials have compared hysteroscopic electro-surgical endometrial ablation to hysterectomy as treatment for heavy menstrual bleeding. Overall, hysterectomy involves longer operating and recovery time, a higher risk for complications, and greater expense but provides a permanent solution; the need for retreatment of many women after ablation narrows the cost difference over time. Satisfaction rates with both procedures are high.<sup>226</sup>

Several additional techniques for endometrial ablation have been developed.<sup>227</sup> Hysteroscopic approaches include a bipolar vaporizing electrode<sup>228</sup> and a hydrothermal technique.<sup>229</sup> There are also balloon devices that contain heated water ( $87^{\circ}\text{C} \pm 5^{\circ}\text{C}$ )<sup>230,231</sup> and another method that uses a gold-plated mesh electrode that conforms to the uterine cavity and ablates with bipolar radiofrequency.<sup>232,233</sup> Still, others employ microwave<sup>234</sup> or cryosurgical technologies.<sup>235</sup> **Compared to traditional hysteroscopic methods, the “blind” techniques for ablation are technically easier to perform, take less time, are more likely to require only local anesthesia, and achieve similar results, but equipment problems are more common.**<sup>196,236</sup>

Although all methods are effective, there are reasons for choosing one method over another in individual women. Cryoablation and thermal balloon ablative devices are available for office use for women who prefer an office-based procedure using minimal or no anesthesia.<sup>236</sup> Radiofrequency electro-surgical ablation is another excellent office-based method and does not require medical pretreatment to thin the endometrium. Hydrothermal ablation is the procedure of choice for women having an abnormally shaped uterine cavity, unrelated to uterine myomas. For women with submucous fibroids smaller than 3 cm, microwave ablation may be ideal, although hysteroscopic myomectomy and roller ball electro-surgical ablation also is appropriate and is

preferred for women with larger submucous myomas ([Table 15.6](#)).

## **TABLE 15.6**

Method	Advantages	Disadvantages
Cryoablation	Not completely blind Less pain than methods using heat energy Requires minimal or no anesthesia	No outcomes data for women with intracavitary lesions
Thermal balloon ablation	First global technique approved for use Easy to learn	Not recommended for women with an abnormal uterine cavity (anomaly, enlarged, polyps, myomas, adhesions)
Hydrothermal ablation	Circulating hot water contacts all endometrial surfaces, regardless of shape Direct visualization of uterine cavity	Not recommended for women with a uterus >10 cm Requires 8 mm hysteroscope Hot water stimulates pain Risk for burns to vagina and perineum
Bipolar radiofrequency ablation	Short procedure time Easy to perform Requires no endometrial pretreatment	Not recommended for women with an enlarged or abnormal uterine cavity
Microwave ablation	Applicable in women with large cavity or small myomas (<3 cm)	Requires pretreatment ultrasonography to document minimum 1 cm myometrial thickness in all areas Contraindicated for women with previous transmural myomectomy or classical cesarean section

Preoperative evaluation before ablation should include thorough examination of the uterine cavity by saline sonography or office hysteroscopy to exclude focal lesions such as polyps and myomas that can be resected and to identify women not having a normally shaped uterine cavity who may not be appropriate candidates for some global ablation methods like the thermal balloon. Best results with ablation can be achieved if the endometrium also is first rendered thin and inactive, to increase the likelihood that ablation will include the basal layer of the endometrium, which is 4–6 mm beneath the surface, depending on the phase of the cycle. Several methods to achieve that purpose have been described, including curettage immediately prior to performing the ablation and preoperative treatment with progestins, estrogen-progestin contraceptives, danazol, or GnRH agonists.<sup>213,237</sup> Bipolar radiofrequency ablation is an exception, in that the technique is equally effective with and without endometrial pretreatment.

**Among women with menorrhagia who undergo an endometrial ablation procedure, 80–90% report reduced bleeding, 25–50% develop amenorrhea, 70–80% report less menstrual pain, 75–90% are satisfied with the surgical outcome, and 80% require no additional surgery up to 5 years after ablation.**<sup>229,231,232,234,235,236,238,239,240</sup> Approximately 15–24% of women who have an endometrial ablation will later have a hysterectomy. Overall, despite the lower risks, fewer complications, and more rapid recovery associated with endometrial ablation, women treated with hysterectomy tend to be more satisfied with the outcome.<sup>241,242,243,244</sup>

For obvious reasons, endometrial ablation is not an appropriate treatment for women who have not completed childbearing. Conversely, endometrial ablation is not a sterilization procedure. Although uncommon, pregnancy is still possible after ablation and is associated with an increased risk for complications, including miscarriage, antepartum hemorrhage, preterm delivery, and abnormal placentation.<sup>245,246</sup> Consequently, sexually active women still require contraception after endometrial ablation.

There are legitimate concerns that endometrial carcinomas might be inadvertently managed by endometrial ablation<sup>247,248</sup> or that the procedure might obliterate portions of the uterine cavity leaving isolated, residual islands of endometrium in which adenocarcinoma could develop and go unrecognized in the absence of bleeding.<sup>249,250</sup> These observations emphasize the importance of thorough preoperative evaluation, to include endometrial biopsy, and proper patient selection for ablation procedures. **Although the risk can never be completely avoided, endometrial ablation is not recommended for women at increased risk for endometrial cancer (obesity, diabetes, hypertension, smoking, family history, chronic anovulation).**<sup>251</sup> **Importantly, in women who have had an endometrial ablation and receive postmenopausal hormone therapy, treatment must include a progestin to minimize the induction of endometrial hyperplasia or cancer from long-term use of estrogen alone.**

Other complications of endometrial ablation include hematometra, cervical stenosis, and uterine perforation. Hematometra develops when active islands of endometrium remain above ablated areas that adhere. Thorough ablation of the upper limits of the cavity, including the cornua and tubal ostia but excluding the cervix and cervical-uterine junction, decreases the risk for complication. Uterine perforation complicates 1% or less of endometrial ablation procedures.

Endometrial ablation can be an effective treatment for women with acute or prolonged bleeding who are hemodynamically stable when medical treatment fails or is contraindicated.<sup>252,253,254,255</sup> In one reported series of 26 women with acute severe bleeding treated by hysteroscopic endometrial resection, no further medical or surgical treatment was required for 24 of the women over 19 months of follow-up; 1 with endometrial cancer detected in the surgical specimen and another with uterine myomas required hysterectomy.<sup>252</sup>

## Key Point: Clinical Principles

Considering that abnormal menstrual bleeding is the single most common complaint

that reproductive-age women bring to their physician, all clinicians who provide primary care for women must have an organized, logical approach to the evaluation and treatment of the problem. The following summarizes the key elements of the clinical evaluation and treatment of abnormal menstrual bleeding in premenopausal women.

# DIAGNOSTIC EVALUATION SUMMARY

---

- Anovulatory bleeding is usually irregular, infrequent, and unpredictable; variable in amount, duration, and character; and most often observed in adolescents and aging women, the obese, and women with the clinical features of PCOS.
- Regular and predictable but increasingly heavy or prolonged periods or new onset of episodic intermenstrual bleeding more often results from a structural abnormality than from anovulation.
- Recurrent episodes of intermenstrual bleeding often result from intrauterine pathology and warrant evaluation.
- The most common cause of a sudden departure from a well-established pattern of predictable menses is a complication of pregnancy.
- The evaluation of women with a complaint of AUB should include a pregnancy test and complete blood count to exclude the possibility of pregnancy and to identify those with anemia and thrombocytopenia.
- When the clinical history and examination clearly point to anovulatory bleeding, empiric medical treatment can be offered without additional laboratory evaluation or imaging.
- A well-timed serum progesterone determination can help to confirm the diagnosis of anovulatory bleeding when doubt exists. A serum TSH can exclude thyroid disorders in anovulatory women. Liver or renal function tests are indicated only for those with known or strongly suspected disease.
- Bleeding disorders are more common than is generally perceived. Coagulation tests are indicated for adolescents with heavy menstrual bleeding from menarche, women with past episodes of excessive bleeding from trauma or surgery, and those with unexplained heavy or prolonged menstrual bleeding.
- Endometrial biopsy should be seriously considered before treatment begins when the clinical history suggests long-term unopposed estrogen exposure, regardless of age, but is unnecessary when the endometrium is very thin (<5 mm). Endometrial biopsy should be considered when the endometrium is abnormally thick (>12 mm), even when clinical suspicion of disease is low.
- Uterine imaging with ultrasound or sonohysterography should be performed when examination reveals abnormal uterine size or contours, when history (regular cycles of increasing volume or duration, new-onset intermenstrual bleeding), laboratory tests (serum progesterone >3 ng/mL), or biopsy results (secretory endometrium) provide objective evidence of ovulation, and when empiric medical treatment fails.
- The combination of sonohysterography and endometrial biopsy has high sensitivity and high negative predictive value for detection of endometrial and uterine

pathology in women with abnormal bleeding.



# TREATMENT SUMMARY

---

- Cyclic progestin therapy is an appropriate treatment for oligomenorrheic anovulatory women with episodic abnormal bleeding who do not need contraception; choice of an estrogen-progestin contraceptive or the LNG-IUS may be preferable in those seeking contraception. Standard cyclic progestin treatments do not reliably suppress the HPO axis, will not prevent random ovulation, and are not contraceptive.
- Estrogen therapy is the best initial treatment when a denuded or attenuated endometrium is strongly suspected or demonstrated. Clinical examples include women in whom optimally performed endometrial biopsy yields minimal tissue, women receiving chronic progestin treatment, and women with prolonged heavy bleeding. Progestin or estrogen-progestin therapy is unlikely to succeed in these situations and may even aggravate the problem.
- Failed medical management for presumed anovulatory bleeding suggests strongly that another pathology is causing or contributing to the bleeding and signals the need for additional diagnostic evaluation.
- In women with acute heavy bleeding, imaging with transvaginal ultrasonography helps to guide the choice of treatment by defining the endometrial thickness and revealing structural abnormalities not otherwise suspected.
- Acute prolonged episodes of heavy anovulatory bleeding can be treated effectively with high-dose estrogen-progestin therapy or with high-dose progestin alone (when estrogen is contraindicated), provided that the endometrium is normal or increased in thickness.
- Treatment with depot medroxyprogesterone acetate has no place in the acute management of abnormal bleeding. Once administered, it cannot be withdrawn, and if unsuccessful, its effects can be difficult to overcome.
- Endometrial curettage should be considered when bleeding is acute and demands immediate action or fails to respond promptly to intensive medical therapy. Hysteroscopy at time of curettage helps to ensure an accurate diagnosis.
- Endometrial hyperplasia without cytologic atypia is an exaggerated form of persistent proliferative endometrium resulting from long-term unopposed estrogen stimulation in women with chronic anovulation. With few exceptions, the lesion can be treated effectively with cyclic or continuous progestin therapy or by insertion of a LNG-IUS.
- Endometrial hyperplasia with cytologic atypia is a precancerous lesion best treated surgically except in women with intent on preserving reproductive potential. Medical management of atypical endometrial hyperplasia requires high doses and longer durations of progestin treatment or insertion of a LNG-IUS, serial

endometrial biopsies to monitor response, and longer-term close surveillance.

- Uterine myomas are extremely common and cannot be regarded as the cause of abnormal bleeding before other possibilities have been excluded, particularly when they do not protrude into or displace the uterine cavity. Sonohysterography clearly defines the proximity of myomas to the uterine cavity and helps to differentiate clinically relevant myomas from those that are not.
- Desmopressin is very effective for the management of heavy menstrual bleeding in women with von Willebrand disease, beginning treatment with the onset of menses. Tranexamic acid, estrogen-progestin contraceptives, or insertion of a LNG-IUS also helps to reduce the volume and duration of menses in women with coagulation disorders.
- Nonsteroidal anti-inflammatory drugs, estrogen-progestin contraceptives, LNG-IUS, and tranexamic acid are effective medical treatment options for the management of heavy menstrual bleeding in ovulatory women with adenomyosis, global cavity enlargement related to multiple intramural leiomyomata, and otherwise unexplained menorrhagia. SPRMs are the newest class of agents available for managing abnormal bleeding in patients with uterine fibroids. LNG-IUS and GnRH $\alpha$  are effective options for managing adenomyosis-related abnormal bleeding.
- Endometrial ablation using hysteroscopic or nonhysteroscopic techniques is an effective alternative to hysterectomy for management of abnormally heavy menstrual bleeding when medical treatments are rejected, unsuccessful, or poorly tolerated.

# REFERENCES

1. **Fraser IS, Critchley HO, Munro MG, Broder M**, A process designed to lead to international agreement on terminologies and definitions used to describe abnormalities of menstrual bleeding, *Fertil Steril* 87:466, 2007.
2. **Woolcock JG, Critchley HO, Munro MG, Broder MS, Fraser IS**, Review of the confusion in current and historical terminology and definitions for disturbances of menstrual bleeding, *Fertil Steril* 90:2269, 2008.
3. **Brenner PF**, Differential diagnosis of abnormal uterine bleeding, *Am J Obstet Gynecol* 175:766, 1996.
4. **Hallberg L, Högdahl A, Nilsson L, Rybo G**, Menstrual blood loss—a population study, *Acta Obstet Gynecol Scand* 45:320, 1966.
5. **Treloar AE, Boynton RE, Behn BG, Brown BW**, Variation of the human menstrual cycle through reproductive life, *Int J Fertil* 12:77, 1967.
6. **Belsey EM, Pinol APY**, Menstrual bleeding patterns in untreated women. Task Force on Long-Acting Systemic Agents for Fertility Regulation, *Contraception* 55:57, 1997.
7. **Ruta DA, Garratt AM, Chadha YC, Flett GM, Hall MH, Russell IT**, Assessment of patients with menorrhagia: how valid is a structured clinical history as a measure of health status?, *Qual Life Res* 4:33, 1995.
8. **Warner P, Critchley HO, Lumsden MA, Campbell-Brown M, Douglas A, Murray G**, Referral for menstrual problems: cross sectional survey of symptoms, reasons for referral, and management, *Br Med J* 323:24, 2001.
9. **Munro MG, Critchley HOD, Fraser IS; FIGO Menstrual Disorders Committee**, The two FIGO systems for normal and abnormal uterine bleeding symptoms and classification of causes of abnormal uterine bleeding in the reproductive years: 2018 revisions, *Int J Gynaecol Obstet* 143:393, 2018.
10. **Töz E, Sancı M, Özcan A, Beyan E, İnan AH**, Comparison of classic terminology with the FIGO PALM-COEIN system for classification of the underlying causes of abnormal uterine bleeding, *Int J Gynaecol Obstet* 133(3):325, 2016.
11. **Madhra M, Fraser IS, Munro MG, Critchley HO**, Abnormal uterine bleeding: advantages of formal classification to patients, clinicians and researchers, *Acta Obstet Gynecol Scand* 93(7):619, 2014.
12. **Munro MG, Critchley HO, Broder MS, Fraser IS; FIGO Working Group on Menstrual Disorders**, FIGO classification system (PALM-COEIN) for causes of abnormal uterine bleeding in nonpregnant women of reproductive age, *Int J Gynaecol Obstet* 113(1):3, 2011.
13. **Bravender T, Emans SJ**, Menstrual disorders. Dysfunctional uterine bleeding, *Pediatr Clin North Am* 46:545, 1999.
14. **Mitan LA, Slap GB**, Adolescent menstrual disorders. Update, *Med Clin North Am* 84:851, 2000.
15. **World Health Organization Task Force on Adolescent Reproductive Health**, World Health Organization multicenter study on menstrual and ovulatory patterns in adolescent girls. II. Longitudinal study of menstrual patterns in the early postmenarcheal period, duration of bleeding episodes and menstrual cycles, *J Adolesc Health Care* 7:236, 1986.
16. **Collett ME, Wertenberger GE, Fiske VM**, The effect of age upon the pattern of the menstrual cycle, *Fertil Steril* 5:437, 1954.
17. **Chiazze L Jr, Brayer FT, Macisco JJ Jr, Parker MP, Duffy BJ**, The length and variability of the human menstrual cycle, *JAMA* 203:377, 1968.
18. **Vollman RF**, The menstrual cycle, In: Friedman E, ed. *Major Problems in Obstetrics and Gynecology*, W.B. Saunders, Philadelphia, 1977.
19. **O'Connor KA, Holman DJ, Wood JW**, Menstrual cycle variability and the perimenopause, *Am J Hum Biol* 13:465, 2001.
20. **Taffe JR, Dennerstein L**, Menstrual patterns leading to the final menstrual period, *Menopause* 9:32, 2002.
21. **Symons JP, Sowers MF, Harlow SD**, Relationship of body composition measures and menstrual cycle length, *Ann Hum Biol* 24:107, 1997.
22. **Rowland AS, Baird DD, Long S, Wegienka G, Harlow SD, Alavanja M, Sandler DP**, Influence of medical conditions and lifestyle factors on the menstrual cycle, *Epidemiology* 13:668, 2002.

23. **Munster K, Schmidt L, Helm P**, Length and variation in the menstrual cycle—a cross-sectional study from a Danish county, *Br J Obstet Gynaecol* 99:422, 1992.
24. **Wood C, Larsen L, Williams R**, Menstrual characteristics of 2,343 women attending the Shepherd Foundation, *Aust N Z J Obstet Gynaecol* 19:107, 1979.
25. **Rybo G**, Menstrual blood loss in relation to parity and menstrual pattern, *Acta Obstet Gynecol Scand* 7:119, 1966.
26. **Haynes PJ, Hodgson H, Anderson ABM, Turnbull AC**, Measurement of menstrual blood loss in patients complaining of menorrhagia, *Br J Obstet Gynaecol* 84:763, 1977.
27. **Cohen BJ, Gibor J**, Anemia and menstrual blood loss, *Obstet Gynecol Surv* 35:597, 1980.
28. **Higham JM, O'Brien PM, Shaw RM**, Assessment of menstrual blood loss using a pictorial chart, *Br J Obstet Gynaecol* 97:734, 1990.
29. **Fraser IS, McCarron G, Markham R**, A preliminary study of factors influencing perception of menstrual blood loss volume, *Am J Obstet Gynecol* 149:788, 1984.
30. **Warner PE, Critchley HO, Lumsden MA, Campbell-Brown M, Douglas A, Murray GD**, Menorrhagia I: measured blood loss, clinical features, and outcome in women with heavy periods: a survey with follow-up data, *Am J Obstet Gynecol* 190:1216, 2004.
31. **Geller SE, Harlow SD, Bernstein SJ**, Differences in menstrual bleeding characteristics, functional status, and attitudes toward menstruation in three groups of women, *J Womens Health Gend Based Med* 8:533, 1999.
32. **Greenberg M**, The meaning of menorrhagia: an investigation into the association between the complaint of menorrhagia and depression, *J Psychosom Res* 27:209, 1983.
33. **Hurskainen R, Aalto AM, Teperi J, Grenman S, Kivela A, Kujansuu E, Vuorma S, Yliskoski M, Paavonen J**, Psychosocial and other characteristics of women complaining of menorrhagia, with and without actual increased menstrual blood loss, *Br J Obstet Gynaecol* 108:281, 2001.
34. **Wright B, Gannon MJ, Greenberg M, House A, Rutherford T**, Psychiatric morbidity following endometrial ablation and its association with genuine menorrhagia, *Br J Obstet Gynaecol* 110:358, 2003.
35. **Markee JE**, Menstruation in intraocular endometrial transplants in the rhesus monkey, *JAMA* 250:2167, 1946.
36. **Markee JE**, Morphological basis for menstrual bleeding: relation of regression to the initiation of bleeding, *Bull N Y Acad Med* 24:253, 1948.
37. **Gannon BJ, Carati CJ, Verco CJ**, Endometrial perfusion across the normal human menstrual cycle assessed by laser Doppler fluxmetry, *Hum Reprod* 12:132, 1997.
38. **Zhang J, Salamonsen LA**, Expression of hypoxia-inducible factors in human endometrium and suppression of matrix metalloproteinases under hypoxic conditions do not support a major role for hypoxia in regulating tissue breakdown at menstruation, *Hum Reprod* 17:265, 2002.
39. **Ferenczy A**, Pathophysiology of endometrial bleeding, *Maturitas* 45:1, 2003.
40. **Tabibzadeh S**, The signals and molecular pathways involved in human menstruation, a unique process of tissue destruction and remodeling, *Mol Hum Reprod* 2:77, 1996.
41. **Salamonsen LA, Zhang J, Brasted M**, Leukocyte networks and human endometrial remodeling, *J Reprod Immunol* 57:95, 2002.
42. **Salamonsen LA**, Tissue injury and repair in the female human reproductive tract, *Reproduction* 125:301, 2003.
43. **Salamonsen LA**, Matrix metalloproteinases and endometrial remodeling, *Cell Biol Int* 18:1139, 1994.
44. **Rodgers WH, Matrisian LM, Giudice LC, Dsupin B, Cannon P, Svitek C, Gorstein F, Osteen KG**, Patterns of matrix metalloproteinase expression in cycling endometrium imply differential functions and regulation by steroid hormones, *J Clin Invest* 94:946, 1994.
45. **Zhang J, Salamonsen LA**, In vivo evidence for active matrix metalloproteinases in human endometrium supports their role in tissue breakdown at menstruation, *J Clin Endocrinol Metab* 87:2346, 2002.
46. **Bruner KL, Rodgers WH, Gold LI, Korc M, Hargrove JT, Matrisian LM, Osteen KG**, Transforming growth factor beta mediates the progesterone suppression of an epithelial metalloproteinase by adjacent stroma in the human endometrium, *Proc Natl Acad Sci U S A* 92:7362, 1995.
47. **Irwin JC, Kirk D, Gwatkin RBL, Navre M, Cannon P, Giudice LC**, Human endometrial matrix metalloproteinase-2, a putative menstrual proteinase. Hormonal regulation in cultured stromal cells and

- messenger RNA expression during the menstrual cycle, *J Clin Invest* 97:438, 1996.
48. **Curry TE Jr, Osteen KG**, Cyclic changes in the matrix metalloproteinase system in the ovary and uterus, *Biol Reprod* 64:1285, 2001.
  49. **Christiaens GC, Sixma JJ, Haspels AA**, Hemostasis in menstrual endometrium: a review, *Obstet Gynecol Surv* 37:281, 1982.
  50. **Giudice LC, Ferenczy A**, The endometrial cycle. Morphologic and biochemical events, In: Adashi EY, Rock JA, Rosenwaks Z, eds. *Reproductive Endocrinology, Surgery, and Technology*, Lippincott-Raven, Philadelphia, 1996, p. 271.
  51. **Lockwood C, Krikun G, Papp C, Toth-Pal E, Markiewicz L, Wang EY, Kerenyi T, Zhou X, Hausknecht V, Papp Z**, The role of progestationally regulated stromal cell tissue factor and type-1 plasminogen activator inhibitor (PAI-1) in endometrial hemostasis and menstruation, *Ann N Y Acad Sci* 734:57, 1994.
  52. **Schatz F, Aigner S, Papp C, Toth-Pal E, Hausknecht V, Lockwood CJ**, Plasminogen activator activity during decidualization of human endometrial stromal cells is regulated by plasminogen activator inhibitor 1, *J Clin Endocrinol Metab* 80:1504, 1995.
  53. **Lockwood CJ, Schatz F**, A biological model for the regulation of peri-implantational hemostasis and menstruation, *J Soc Gynecol Investig* 3:159, 1996.
  54. **Okulicz WC, Scarrell R**, Estrogen receptor alpha and progesterone receptor in the rhesus endometrium during the late secretory phase and menses, *Proc Soc Exp Biol Med* 218:316, 1998.
  55. **Bigsby RM**, Control of growth and differentiation of the endometrium: the role of tissue interactions, *Ann N Y Acad Sci* 955:110, 2002.
  56. **Graubert MD, Ortega MA, Kessel B, Mortola JF, Iruela-Arispe ML**, Vascular repair after menstruation involves regulation of vascular endothelial growth factor-receptor phosphorylation by sFLT-1, *Am J Pathol* 158:1399, 2001.
  57. **Nayak NR, Brenner RM**, Vascular proliferation and vascular endothelial growth factor expression in the rhesus macaque endometrium, *J Clin Endocrinol Metab* 87:1845, 2002.
  58. **Jones RL, Salamonsen LA, Findlay JK**, Potential roles for endometrial inhibins, activins and follistatin during human embryo implantation and early pregnancy, *Trends Endocrinol Metab* 13:144, 2002.
  59. **de Ziegler D, Bergeron C, Cornel C, Medalie A, Massai MR, Milgrom E, Frydman R, Bouchard P**, Effects of luteal estradiol on the secretory transformation of human endometrium and plasma gonadotropins, *J Clin Endocrinol Metab* 74:322, 1992.
  60. **Belsey EM**, Vaginal bleeding patterns among women using one natural and eight hormonal methods of contraception, *Contraception* 38:181, 1988.
  61. **Gallo MF, Nanda K, Grimes DA, Lopez LM, Schulz KF**, 20 µg versus >20 µg estrogen combined oral contraceptives for contraception, *Cochrane Database Syst Rev* (8):CD003989, 2013.
  62. **Horbelt DV, Roberts DK, Parmley TH, Walker NJ**, Ultrastructure of the microvasculature in human endometrial hyperplasia, *Am J Obstet Gynecol* 174:174, 1996.
  63. **Abulafia O, Sherer DM**, Angiogenesis of the endometrium, *Obstet Gynecol* 94:148, 1999.
  64. **Smith SK, Abel MH, Kelly RW, Baird DT**, The synthesis of prostaglandins from persistent proliferative endometrium, *J Clin Endocrinol Metab* 55:284, 1982.
  65. **Levgur M**, Diagnosis of adenomyosis: a review, *J Reprod Med* 52:177, 2007.
  66. **Ferenczy A**, Pathophysiology of adenomyosis, *Hum Reprod Update* 4:312, 1998.
  67. **Enatsu A, Harada T, Yoshida S, Iwabe T, Terakawa N**, Adenomyosis in a patient with the Rokitansky-Küster-Hauser syndrome, *Fertil Steril* 73:862, 2000.
  68. **Mori T, Singtripop T, Kawashima S**, Animal model of uterine adenomyosis: is prolactin a potent inducer of adenomyosis in mice?, *Am J Obstet Gynecol* 165:232, 1991.
  69. **Bazot M, Darai E, Rouger J, Detchev R, Cortez A, Uzan S**, Limitations of transvaginal sonography for the diagnosis of adenomyosis, with histopathological correlation, *Ultrasound Obstet Gynecol* 20:605, 2002.
  70. **Meredith SM, Sanchez-Ramos L, Kaunitz AM**, Diagnostic accuracy of transvaginal sonography for the diagnosis of adenomyosis: systematic review and metaanalysis, *Am J Obstet Gynecol* 201:107.e1, 2009.

71. **Ascher SM, Arnold LL, Patt RH, Schrufer JJ, Bagley AS, Semelka RC, Zeman RK, Simon JA**, Adenomyosis: prospective comparison of MR imaging and transvaginal sonography, *Radiology* 190:803, 1994.
72. **Bazot M, Cortez A, Darai E, Rouger J, Chopier J, Antoine JM, Uzan S**, Ultrasonography compared with magnetic resonance imaging for the diagnosis of adenomyosis: correlation with histopathology, *Hum Reprod* 16:2427, 2001.
73. **Gordts S, Grimbizis G, Campo R**, Symptoms and classification of uterine adenomyosis, including the place of hysteroscopy in diagnosis, *Fertil Steril* 109(3):380.e1, 2018.
74. **Di Spiezio Sardo A, Calagna G, Santangelo F, Zizolfi B, Tanos V, Perino A, De Wilde RL**, The role of hysteroscopy in the diagnosis and treatment of adenomyosis, *Biomed Res Int* 2017:2518396, 2017.
75. **Molinas CR, Campo R**, Office hysteroscopy and adenomyosis, *Best Pract Res Clin Obstet Gynaecol* 20(4):557, 2006.
76. **Becker E Jr, Lev-Toaff AS, Kaufman EP, Halpern EJ, Edelweiss MI, Kurtz AB**, The added value of transvaginal sonohysterography over transvaginal sonography alone in women with known or suspected leiomyoma, *J Ultrasound Med* 21:237, 2002.
77. **Patterson-Keels LM, Selvaggi SM, Haefner HK, Randolph JF Jr**, Morphologic assessment of endometrium overlying submucosal leiomyomas, *J Reprod Med* 39:579, 1994.
78. **Sosic A, Skupski DW, Streltsoff J, Yun H, Chervenak FA**, Vascularity of uterine myomas: assessment by color and pulsed Doppler ultrasound, *Int J Gynaecol Obstet* 54:245, 1996.
79. **Kurman RJ, Norris HJ**, Endometrial hyperplasia and related cellular changes, In: Kurman RJ, ed. *Blaustein's Pathology of the Female Genital Tract*, Springer-Verlag, New York, 1994, p. 441.
80. **Emons G, Beckmann MW, Schmidt D, Mallmann P; Uterus commission of the Gynecological Oncology Working Group (AGO)**, New WHO classification of endometrial hyperplasias, *Geburtsh Frauenheilk* 75:135, 2015.
81. **Kurman RJ, Kaminski PF, Norris HJ**, The behavior of endometrial hyperplasia. A long-term study of "untreated" hyperplasia in 170 patients, *Cancer* 56:403, 1985.
82. **Ferenczy A, Gelfand M**, The biologic significance of cytologic atypia in progestogen-treated endometrial hyperplasia, *Am J Obstet Gynecol* 160:126, 1989.
83. **Hunter JE, Tritz DE, Howell MG, DePriest PD, Gallion HH, Andrews SJ, Buckley SB, Kryscio RJ, van Nagell JR Jr**, The prognostic and therapeutic implications of cytologic atypia in patients with endometrial hyperplasia, *Gynecol Oncol* 55:66, 1994.
84. **Tabata T, Yamawaki T, Yabana T, Ida M, Nishimura K, Nose Y**, Natural history of endometrial hyperplasia. Study of 77 patients, *Arch Gynecol Obstet* 265:85, 2001.
85. **Zaino RJ, Kauderer J, Trimble CL, Silverberg SG, Curtin JP, Lim PC, Gallup DG**, Reproducibility of the diagnosis of atypical endometrial hyperplasia: a Gynecologic Oncology Group study, *Cancer* 106:804, 2006.
86. **Kendall BS, Ronnett BM, Isacson C, Cho KR, Hedrick L, Diener-West M, Kurman RJ**, Reproducibility of the diagnosis of endometrial hyperplasia, atypical hyperplasia, and well-differentiated carcinoma, *Am J Surg Pathol* 22: 1012, 1998.
87. **Bergeron C, Nogales FF, Masseroli M, Abeler V, Duvillard P, Muller-Holzner E, Pickartz H, Wells M**, A multicentric European study testing the reproducibility of the WHO classification of endometrial hyperplasia with a proposal of a simplified working classification for biopsy and curettage specimens, *Am J Surg Pathol* 23:1102, 1999.
88. **Mutter GL**, Endometrial intraepithelial neoplasia (EIN): will it bring order to chaos? The Endometrial Collaborative Group, *Gynecol Oncol* 76:287, 2000.
89. **Suh-Burgmann E, Hung YY, Armstrong MA**, Complex atypical endometrial hyperplasia: the risk of unrecognized adenocarcinoma and value of preoperative dilation and curettage, *Obstet Gynecol* 114:523, 2009.
90. **Claessens EA, Cowell CL**, Acute adolescent menorrhagia, *Am J Obstet Gynecol* 139:377, 1981.
91. **Smith YR, Quint EH, Hertzberg RB**, Menorrhagia in adolescents requiring hospitalization, *J Pediatr Adolesc Gynecol* 11:13, 1998.
92. **Oral E, Cagdas A, Gezer A, Kaleli S, Aydin Y, Ocer F**, Hematological abnormalities in adolescent menorrhagia, *Arch Gynecol Obstet* 266:72, 2002.

93. **Kanbur NO, Derman O, Kutluk T, Gurgey A**, Coagulation disorders as the cause of menorrhagia in adolescents, *Int J Adolesc Med Health* 16:183, 2004.
94. **van Eijkeren MA, Christiaens GC, Haspels AA, Sixma JJ**, Measured menstrual blood loss in women with a bleeding disorder or using oral anticoagulant therapy, *Am J Obstet Gynecol* 162:1261, 1990.
95. **Edlund M, Blomback M, von Schoultz B, Andersson O**, On the value of menorrhagia as a predictor for coagulation disorders, *Am J Hematol* 53:234, 1996.
96. **Kadir RA, Economides DL, Sabin CA, Owens D, Lee CA**, Frequency of inherited bleeding disorders in women with menorrhagia, *Lancet* 351:485, 1998.
97. **Dilley A, Drews C, Miller C, Lally C, Austin H, Ramaswamy D, Lurye D, Evatt B**, von Willebrand disease and other inherited bleeding disorders in women with diagnosed menorrhagia, *Obstet Gynecol* 97:630, 2001.
98. **Kouides PA**, Evaluation of abnormal bleeding in women, *Curr Hematol Rep* 1:11, 2002.
99. **Kouides PA, Conard J, Peyvandi F, Lukes A, Kadir R**, Hemostasis and menstruation: appropriate investigation for underlying disorders of hemostasis in women with excessive menstrual bleeding, *Fertil Steril* 84:1345, 2005.
100. **Ghosh K, Trasi S, Nair S, Shetty S, Mohanty D**, Prevalence of inherited bleeding disorders in cases of idiopathic menorrhagia: a case of five blind men describing an elephant, *J Thromb Haemost* 1:2242, 2003.
101. **Philipp T, Philipp K, Reiner A, Beer F, Kalousek DK**, Embryoscopic and cytogenetic analysis of 233 missed abortions: factors involved in the pathogenesis of developmental defects of early failed pregnancies, *Hum Reprod* 18:1724, 2003.
102. **Ruggeri ZM, Ware J**, von Willebrand factor, *FASEB J* 7:308, 1993.
103. **Wagner DD**, Cell biology of von Willebrand factor, *Annu Rev Cell Biol* 6:217, 1990.
104. **Sadler JE**, Biochemistry and genetics of von Willebrand factor, *Annu Rev Biochem* 67:395, 1998.
105. **Sadler JE, Budde U, Eikenboom JC, Favaloro EJ, Hill FG, Holmberg L, Ingerslev J, Lee CA, Lillierap D, Mannucci PM, Mazurier C, Meyer D, Nichols WL, Nishino M, Peake IR, Rodeghiero F, Schneppenheim R, Ruggeri ZM, Srivastava A, Montgomery RR, Federici AB**, Update on the pathophysiology and classification of von Willebrand disease: a report of the Subcommittee on von Willebrand Factor, *J Thromb Haemost* 4:2103, 2006.
106. **Mazurier C, Ribba AS, Gaucher C, Meyer D**, Molecular genetics of von Willebrand disease, *Ann Genet* 41:34, 1998.
107. **Pramanick A, Hwang WS, Mathur M**, Placental site nodule (PSN): an uncommon diagnosis with a common presentation, *BMJ Case Rep* 2014, 2014.
108. **Hopkins MP, Androff L, Benninghoff AS**, Ginseng face cream and unexplained vaginal bleeding, *Am J Obstet Gynecol* 159:1121, 1988.
109. **Vasudeva K, Thrasher TV, Richart RM**, Chronic endometritis: a clinical and electron microscopic study, *Am J Obstet Gynecol* 112:749, 1972.
110. **Manolitsas T, Hurley V, Gilford E**, Uterine arteriovenous malformation—a rare cause of uterine haemorrhage, *Aust N Z J Obstet Gynaecol* 34(2):197, 1994.
111. **Hallberg L, Nillson L**, Determination of menstrual blood loss, *Scand J Clin Lab Invest* 16:244, 1964.
112. **Shaw ST Jr, Aaronson DE, Moyer MD**, Quantitation of menstrual blood loss—Further evaluation of the alkaline hematin method, *Contraception* 5:497, 1972.
113. **Wyatt KM, Dimmock PW, Walker TJ, O'Brien PM**, Determination of total menstrual blood loss, *Fertil Steril* 76:125, 2001.
114. **Magnay JL, O'Brien S, Gerlinger C, Seitz C**, A systematic review of methods to measure menstrual blood loss, *BMC Womens Health* 18(1):142, 2018.
115. **Fraser IS, Warner P, Marantos PA**, Estimating menstrual blood loss in women with normal and excessive menstrual fluid volume, *Obstet Gynecol* 98: 806, 2001.
116. **Wathen NC, Perry L, Lilford RJ, Chard T**, Interpretation of single progesterone measurement in diagnosis of anovulation and defective luteal phase: observations on analysis of the normal range, *Br Med J* 288:7, 1984.
117. **Drews CD, Dilley AB, Lally C, Beckman MG, Evatt B**, Screening questions to identify women with von

Willebrand disease, *J Am Med Womens Assoc* 57:217, 2002.

118. **Lukes AS, Kadir RA, Peyvandi F, Kouides PA**, Disorders of hemostasis and excessive menstrual bleeding: prevalence and clinical impact, *Fertil Steril* 84:1338, 2005.
119. **Fricke W, Kouides P, Kessler C, Schmaier AH, Krijanovski Y, Jagadeesan K, Joist J**, A multicenter clinical evaluation of the Clot Signature Analyzer, *J Thromb Haemost* 2:763, 2004.
120. **Mannucci PM, Duga S, Peyvandi F**, Recessively inherited coagulation disorders, *Blood* 104:1243, 2004.
121. **Demers C, Derzko C, David M, Douglas J**, Gynaecological and obstetric management of women with inherited bleeding disorders, *Int J Gynaecol Obstet* 95:75, 2006.
122. **Abildgaard CF, Suzuki Z, Harrison J, Jefcoat K, Zimmerman TS**, Serial studies in von Willebrand's disease: variability versus "variants", *Blood* 56:712, 1980.
123. **Miller CH, Dilley AB, Drews C, Richardson L, Evatt B**, Changes in von Willebrand factor and factor VIII levels during the menstrual cycle, *Thromb Haemost* 87:1082, 2002.
124. **Gill JC, Endres-Brooks J, Bauer PJ, Marks WJ Jr, Montgomery RR**, The effect of ABO blood group on the diagnosis of von Willebrand disease, *Blood* 69:1691, 1987.
125. **Philipp CS, Dilley A, Miller CH, Evatt B, Baranwal A, Schwartz R, Bachmann G, Saidi P**, Platelet functional defects in women with unexplained menorrhagia, *J Thromb Haemost* 1:477, 2003.
126. **Gallup DG, Stock RJ**, Adenocarcinoma of the endometrium in women 40 years of age or younger, *Obstet Gynecol* 64:417, 1984.
127. **Farhi DC, Nosanchuk J, Silverberg SG**, Endometrial adenocarcinoma in women under 25 years of age, *Obstet Gynecol* 68:741, 1986.
128. **Colafranceschi M, Taddei GL, Scarselli G, Branconi F, Tinacci G, Savino L**, Clinico-pathological profile of endometrial carcinoma in young women (under 40 years of age), *Eur J Gynaecol Oncol* 10:353, 1989.
129. **Gotlieb WH, Beiner ME, Shalmon B, Korach Y, Segal Y, Zmira N, Koupolovic J, Ben-Baruch G**, Outcome of fertility-sparing treatment with progestins in young patients with endometrial cancer, *Obstet Gynecol* 102:718, 2003.
130. **Ash SJ, Farrell SA, Flowerdew G**, Endometrial biopsy in DUB, *J Reprod Med* 41:892, 1996.
131. **Eddowes HA, Read MD, Codling BW**, Pipelle: a more acceptable technique for outpatient endometrial biopsy, *Br J Obstet Gynaecol* 97:961, 1990.
132. **Silver MM, Miles P, Rosa C**, Comparison of Novak and Pipelle endometrial biopsy instruments, *Obstet Gynecol* 78:828, 1991.
133. **Fothergill DJ, Brown VA, Hill AS**, Histological sampling of the endometrium—a comparison between formal curettage and the Pipelle sampler, *Br J Obstet Gynaecol* 99:779, 1992.
134. **Dubinsky T, Abu-Gazze Y, Stroehlein K**, Role of transvaginal sonography and endometrial biopsy in the evaluation of dysfunctional uterine bleeding in premenopausal women, *J Clin Ultrasound* 26:180, 1998.
135. **Caspi B, Appelman Z, Goldchmit R, Ashkenazi M, Haruvy Y, Hagay Z**, The bright edge of the endometrial polyp, *Ultrasound Obstet Gynecol* 15(4):327, 2000.
136. **Smith-Bindman R, Kerlikowske K, Feldstein VA, Subak L, Scheidler J, Segal M, Brand R, Grady D**, Endovaginal ultrasound to exclude endometrial cancer and other endometrial abnormalities, *JAMA* 280:1510, 1998.
137. **Gupta JK, Chien PF, Voit D, Clark TJ, Khan KS**, Ultrasonographic endometrial thickness for diagnosing endometrial pathology in women with postmenopausal bleeding: a meta-analysis, *Acta Obstet Gynecol Scand* 81:799, 2002.
138. **Gull B, Karlsson B, Milsom I, Granberg S**, Can ultrasound replace dilation and curettage? A longitudinal evaluation of postmenopausal bleeding and transvaginal sonographic measurement of the endometrium as predictors of endometrial cancer, *Am J Obstet Gynecol* 188:401, 2003.
139. **Paraskevaidis E, Kalantaridou SN, Papadimitriou D, Pappa L, Malamou-Mitsi V, Zikopoulos K, Kazantzis E, Lolis ED, Agnantis NJ**, Transvaginal uterine ultrasonography compared with endometrial biopsy for the detection of endometrial disease in perimenopausal women with uterine bleeding, *Anticancer Res* 22:1829, 2002.
140. **Breitkopf D, Goldstein SR, Seeds JW**, ACOG technology assessment in obstetrics and gynecology.



Number 3, September 2003. Saline infusion sonohysterography, *Obstet Gynecol* 102:659, 2003.

141. **Leone FP, Lanzani C, Ferrazzi E**, Use of strict sonohysterographic methods for preoperative assessment of submucous myomas, *Fertil Steril* 79:998, 2003.
142. **Sylvestre C, Child TJ, Tulandi T, Tan SL**, A prospective study to evaluate the efficacy of two- and three-dimensional sonohysterography in women with intrauterine lesions, *Fertil Steril* 79:1222, 2003.
143. **Mihm LM, Quick VA, Brumfield JA, Connors AF Jr, Finnerty JJ**, The accuracy of endometrial biopsy and saline sonohysterography in the determination of the cause of abnormal uterine bleeding, *Am J Obstet Gynecol* 186:858, 2002.
144. **Bradley LD, Falcone T, Magen AB**, Radiographic imaging techniques for the diagnosis of abnormal uterine bleeding, *Obstet Gynecol Clin North Am* 27:245, 2000.
145. **Cicinelli E, Resta L, Nicoletti R, Tartagni M, Marinaccio M, Bulletti C, Colafoglio G**, Detection of chronic endometritis at fluid hysteroscopy, *J Minim Invasive Gynecol* 12(6):514, 2005.
146. **Lindheim SR, Kavic S, Shulman SV, Sauer MV**, Operative hysteroscopy in the office setting, *J Am Assoc Gynecol Laparosc* 7:65, 2000.
147. **March CM**, Bleeding problems and treatment, *Clin Obstet Gynecol* 41:928, 1998.
148. **Gurpide E, Gusberg S, Tseng L**, Estradiol binding and metabolism in human endometrial hyperplasia and adenocarcinoma, *J Steroid Biochem* 7:891, 1976.
149. **Kirkland JL, Murthy L, Stancel GM**, Progesterone inhibits the estrogen-induced expression of c-fos messenger ribonucleic acid in the uterus, *Endocrinology* 130:3223, 1992.
150. **Bayer SR, DeCherney AH**, Clinical manifestations and treatment of dysfunctional uterine bleeding, *JAMA* 269:1823, 1993.
151. **Aksu F, Madazli R, Budak E, Cepni I, Benian A**, High-dose medroxyprogesterone acetate for the treatment of dysfunctional uterine bleeding in 24 adolescents, *Aust N Z J Obstet Gynaecol* 37:228, 1997.
152. **Munro MG, Mainor N, Basu R, Brisinger M, Barreda L**, Oral medroxyprogesterone acetate and combination oral contraceptives for acute uterine bleeding: a randomized controlled trial, *Obstet Gynecol* 108:924, 2006.
153. U.S. Medical Eligibility Criteria for Contraceptive Use, [www.cdc.gov/reproductivehealth/unintendedpregnancy/usmec.htm](http://www.cdc.gov/reproductivehealth/unintendedpregnancy/usmec.htm)
154. **Nelson L, Rybo G**, Treatment of menorrhagia, *Am J Obstet Gynecol* 110:713, 1971.
155. **Bradley LD, Gueye NA**, The medical management of abnormal uterine bleeding in reproductive-aged women, *Am J Obstet Gynecol* 214(1):31, 2016.
156. **Ely JW, Kennedy CM, Clark EC, Bowdler NC**, Abnormal uterine bleeding: a management algorithm, *J Am Board Fam Med* 19(6):590, 2006.
157. <https://www.uptodate.com/contents/managing-an-episode-of-severe-or-prolonged-uterine-bleeding#!>
158. **Diaz S, Croxatto HB, Pavez M, Belhadj H, Stern J, Sivin I**, Clinical assessment of treatments for prolonged bleeding in users of Norplant implants, *Contraception* 42:97, 1990.
159. **Livio M, Mannucci PM, Vigano G, Mingardi G, Lombardi R, Mecca G, Remuzzi G**, Conjugated estrogens for the management of bleeding associated with renal failure, *N Engl J Med* 315:731, 1986.
160. **Heisteringer M, Stockenhuber F, Schneider B, Pabinger I, Brenner B, Wagner B, Balcke P, Lechner K, Kyrle PA**, Effect of conjugated estrogens on platelet function and prostacyclin generation in CRF, *Kidney Int* 38:1181, 1990.
161. **DeVore GR, Owens O, Kase N**, Use of intravenous premarin in the treatment of dysfunctional uterine bleeding—a double-blind randomized control study, *Obstet Gynecol* 59:285, 1982.
162. **Zreik TG, Odunsi K, Cass I, Olive DL, Sarrel P**, A case of fatal pulmonary thromboembolism associated with the use of intravenous estrogen therapy, *Fertil Steril* 71:373, 1999.
163. **Hamilton JV, Knab DR**, Suction curettage: therapeutic effectiveness in dysfunctional uterine bleeding, *Obstet Gynecol* 45:47, 1975.
164. **Gimpelson RJ, Rappold HO**, A comparative study between panoramic hysteroscopy with directed biopsies and dilatation and curettage. A review of 276 cases, *Am J Obstet Gynecol* 158:489, 1988.
165. **Huang FJ, Kung FT, Chang SY, Hsu TY**, Effects of short-course buserelin therapy on adenomyosis. A

report of two cases, *J Reprod Med* 44:741, 1999.

166. **Fong YF, Singh K**, Medical treatment of a grossly enlarged adenomyotic uterus with the levonorgestrel-releasing intrauterine system, *Contraception* 60:173, 1999.
167. **Fedele L, Bianchi S, Raffaelli R, Portuese A, Dorta M**, Treatment of adenomyosis-associated menorrhagia with a levonorgestrel-releasing intrauterine device, *Fertil Steril* 68:426, 1997.
168. **Kitawaki J**, Adenomyosis: the pathophysiology of an oestrogen-dependent disease, *Best Pract Res Clin Obstet Gynaecol* 20:493, 2006.
169. **Bragheto AM, Caserta N, Bahamondes L, Petta CA**, Effectiveness of the levonorgestrel-releasing intrauterine system in the treatment of adenomyosis diagnosed and monitored by magnetic resonance imaging, *Contraception* 76:195, 2007.
170. **Sheng J, Zhang WY, Zhang JP, Lu D**, The LNG-IUS study on adenomyosis: a 3-year follow-up study on the efficacy and side effects of the use of levonorgestrel intrauterine system for the treatment of dysmenorrhea associated with adenomyosis, *Contraception* 79:189, 2009.
171. **Pelage JP, Jacob D, Fazel A, Namur J, Laurent A, Rymer R, Le Dref O**, Midterm results of uterine artery embolization for symptomatic adenomyosis: initial experience, *Radiology* 234:948, 2005.
172. **Kitamura Y, Allison SJ, Jha RC, Spies JB, Flick PA, Ascher SM**, MRI of adenomyosis: changes with uterine artery embolization, *Am J Roentgenol* 186:855, 2006.
173. **Kim MD, Kim S, Kim NK, Lee MH, Ahn EH, Kim HJ, Cho JH, Cha SH**, Long-term results of uterine artery embolization for symptomatic adenomyosis, *Am J Roentgenol* 188:176, 2007.
174. **Affinito P, Di Carlo C, Di Mauro P, Napolitano V, Nappi C**, Endometrial hyperplasia: efficacy of a new treatment with a vaginal cream containing natural micronized progesterone, *Maturitas* 20:191, 1994.
175. **Perino A, Quartararo P, Catinella E, Genova G, Cittadini E**, Treatment of endometrial hyperplasia with levonorgestrel releasing intrauterine devices, *Acta Eur Fertil* 18:137, 1987.
176. **Wildemeersch D, Dhont M**, Treatment of nonatypical and atypical endometrial hyperplasia with a levonorgestrel-releasing intrauterine system, *Am J Obstet Gynecol* 188:1297, 2003.
177. **Vereide AB, Arnes M, Straume B, Maltau JM, Orbo A**, Nuclear morphometric changes and therapy monitoring in patients with endometrial hyperplasia: a study comparing effects of intrauterine levonorgestrel and systemic medroxyprogesterone, *Gynecol Oncol* 91:526, 2003.
178. **Wildemeersch D, Janssens D, Pylyser K, De Wever N, Verbeeck G, Dhont M, Tjalma W**, Management of patients with non-atypical and atypical endometrial hyperplasia with a levonorgestrel-releasing intrauterine system: long-term follow-up, *Maturitas* 57:210, 2007.
179. **Randall TC, Kurman RJ**, Progestin treatment of atypical hyperplasia and well-differentiated carcinoma of the endometrium in women under age 40, *Obstet Gynecol* 90:434, 1997.
180. **Kaku T, Yoshikawa H, Tsuda H, Sakamoto A, Fukunaga M, Kuwabara Y, Hataeg M, Kodama S, Kuzuya K, Sato S, Nishimura T, Hiura M, Nakano H, Iwasaka T, Miyazaki K, Kamura T**, Conservative therapy for adenocarcinoma and atypical endometrial hyperplasia of the endometrium in young women: central pathologic review and treatment outcome, *Cancer Lett* 167:39, 2001.
181. **Wheeler DT, Bristow RE, Kurman RJ**, Histologic alterations in endometrial hyperplasia and well-differentiated carcinoma treated with progestins, *Am J Surg Pathol* 31:988, 2007.
182. **Kadir RA, Lukes AS, Kouides PA, Fernandez H, Goudemand J**, Management of excessive menstrual bleeding in women with hemostatic disorders, *Fertil Steril* 84:1352, 2005.
183. **Kadir RA, Economides DL, Sabin CA, Pollard D, Lee CA**, Assessment of menstrual blood loss and gynaecological problems in patients with inherited bleeding disorders, *Haemophilia* 5:40, 1999.
184. **Kadir RA, Lee CA, Sabin CA, Pollard D, Economides DL**, DDAVP nasal spray for treatment of menorrhagia in women with inherited bleeding disorders: a randomized placebo-controlled crossover study, *Haemophilia* 8:787, 2002.
185. **Moffat EH, Giddings JC, Bloom AL**, The effect of desamino-D-arginine vasopressin (DDAVP) and naloxone infusions on factor VIII and possible endothelial cell (EC) related activities, *Br J Haematol* 57:651, 1984.
186. **Lethagen S, Ragnarson Tennvall G**, Self-treatment with desmopressin intranasal spray in patients with

bleeding disorders: effect on bleeding symptoms and socioeconomic factors, *Ann Hematol* 66:257, 1993.

187. **Amesse LS, Pfaff-Amesse T, Leonardi R, Uddin D, French JA II**, Oral contraceptives and DDAVP nasal spray: patterns of use in managing vWD-associated menorrhagia: a single-institution study, *J Pediatr Hematol Oncol* 27:357, 2005.
188. **Kouides PA, Byams VR, Philipp CS, Stein SF, Heit JA, Lukes AS, Skerrette NI, Dowling NF, Evatt BL, Miller CH, Owens S, Kulkarni R**, Multisite management study of menorrhagia with abnormal laboratory haemostasis: a prospective crossover study of intranasal desmopressin and oral tranexamic acid, *Br J Haematol* 145:212, 2009.
189. **Mohri H**, High dose of tranexamic acid for treatment of severe menorrhagia in patients with von Willebrand disease, *J Thromb Thrombolysis* 14:255, 2002.
190. **Lee CA**, Women and inherited bleeding disorders: menstrual issues, *Semin Hematol* 36:21, 1999.
191. **Petitti DB**, Clinical practice. Combination estrogen-progestin oral contraceptives, *N Engl J Med* 349:1443, 2003.
192. **Song D, Feng X, Zhang Q, Xia E, Xiao Y, Xie W, Li TC**, Prevalence and confounders of chronic endometritis in premenopausal women with abnormal bleeding or reproductive failure, *Reprod Biomed Online* 36(1):78, 2018.
193. **Kitaya K, Matsubayashi H, Takaya Y, Nishiyama R, Yamaguchi K, Takeuchi T, Ishikawa T**, Live birth rate following oral antibiotic treatment for chronic endometritis in infertile women with repeated implantation failure, *Am J Reprod Immunol* 78(5), 2017.
194. **Cicinelli E, Matteo M, Tinelli R, Pinto V, Marinaccio M, Indraccolo U, De Ziegler D, Resta L**, Chronic endometritis due to common bacteria is prevalent in women with recurrent miscarriage as confirmed by improved pregnancy outcome after antibiotic treatment, *Reprod Sci* 21(5):640, 2014.
195. **Moreno I, Cicinelli E, Garcia-Grau I, Gonzalez-Monfort M, Bau D, Vilella F, De Ziegler D, Resta L, Valbuena D, Simon C**, The diagnosis of chronic endometritis in infertile asymptomatic women: a comparative study of histology, microbial cultures, hysteroscopy, and molecular microbiology, *Am J Obstet Gynecol* 218(6):602.e1, 2018.
196. **Munro MG**, Dysfunctional uterine bleeding: advances in diagnosis and treatment, *Curr Opin Obstet Gynecol* 13:475, 2001.
197. **Fraser IS**, Prostaglandin inhibitors in gynaecology, *Aust N Z J Obstet Gynecol* 25:114, 1985.
198. **Pedron N, Lozano M, Aznar R**, Treatment of hypermenorrhea with mefenamic acid in women using IUDs, *Contracept Deliv Syst* 3:135, 1982.
199. **Topozada M, Anwar M, Abdel Rahman H, Gaweesh S**, Control of IUD-induced bleeding by three non-steroidal anti-inflammatory drugs, *Contracept Deliv Syst* 3:117, 1982.
200. **Hall P, Maclachlan N, Thorn N, Nudd MWE, Taylor CG, Garrioch DB**, Control of menorrhagia by the cyclo-oxygenase inhibitors naproxen sodium and mefenamic acid, *Br J Obstet Gynaecol* 94:554, 1987.
201. **Shaw RW**, Assessment of medical treatments for menorrhagia, *Br J Obstet Gynaecol* 101(Suppl 11):15, 1994.
202. **Lethaby A, Augood C, Duckitt K**, Nonsteroidal anti-inflammatory drugs for heavy menstrual bleeding, *Cochrane Database Syst Rev* (2):CD000400, 2002.
203. **Fraser IS, McCarron G**, Randomized trial of 2 hormonal and 2 prostaglandin-inhibiting agents in women with a complaint of menorrhagia, *Aust N Z J Obstet Gynecol* 31:66, 1991.
204. **Iyer V, Farquhar C, Jepson R**, Oral contraceptive pills for heavy menstrual bleeding, *Cochrane Database Syst Rev* CD000154, 2003.
205. **Stewart A, Cummins C, Gold L, Jordan R, Phillips W**, The effectiveness of the levonorgestrel-releasing intrauterine system in menorrhagia: a systematic review, *Br J Obstet Gynaecol* 108:74, 2001.
206. **Lethaby AE, Cooke I, Rees M**, Progesterone/progestogen releasing intrauterine systems versus either placebo or any other medication for heavy menstrual bleeding, *Cochrane Database Syst Rev* CD002126, 2003.
207. **Lethaby A, Irvine G, Cameron I**, Cyclical progestogens for heavy menstrual bleeding, *Cochrane Database Syst Rev* CD001016, 2003.
208. **Reid PC, Virtanen-Kari S**, Randomised comparative trial of the levonorgestrel intrauterine system and mefenamic acid for the treatment of idiopathic menorrhagia: a multiple analysis using total menstrual fluid loss,

- menstrual blood loss and pictorial blood loss assessment charts, *Br J Obstet Gynaecol* 112:1121, 2005.
209. **Lethaby A, Augood C, Duckitt K**, Nonsteroidal anti-inflammatory drugs for heavy menstrual bleeding, *Cochrane Database Syst Rev* (2):CD000400, 2000.
  210. **Milsom I, Andersson K, Andersch B, Rybo G**, A comparison of flurbiprofen, tranexamic acid, and a levonorgestrel-releasing intrauterine contraceptive device in the treatment of idiopathic menorrhagia, *Am J Obstet Gynecol* 164:879, 1991.
  211. **Lethaby AE, Cooke I, Rees M**, Progesterone or progestogen-releasing intrauterine systems for heavy menstrual bleeding, *Cochrane Database Syst Rev* (4):CD002126, 2005.
  212. **Kaunitz AM, Meredith S, Inki P, Kubba A, Sanchez-Ramos L**, Levonorgestrel-releasing intrauterine system and endometrial ablation in heavy menstrual bleeding: a systematic review and meta-analysis, *Obstet Gynecol* 113:1104, 2009.
  213. **Sowter MC, Lethaby A, Singla AA**, Pre-operative endometrial thinning agents before endometrial destruction for heavy menstrual bleeding, *Cochrane Database Syst Rev* (3):CD001124, 2002.
  214. **Carr BR, Stewart EA, Archer DF, Al-Hendy A, Bradley L, Watts NB, Diamond MP, Gao J, Owens CD, Chwalisz K, Duan WR, Soliman AM, Dufek MB, Simon JA**, Elagolix alone or with add-back therapy in women with heavy menstrual bleeding and uterine leiomyomas: a randomized controlled trial, *Obstet Gynecol* 132:1252, 2018.
  215. **Murji A, Whitaker L, Chow TL, Sobel ML**, Selective progesterone receptor modulators (SPRMs) for uterine fibroids, *Cochrane Database Syst Rev* (4):CD010770, 2017.
  216. **Donnez J, Vazquez F, Tomaszewski J, Nouri K, Bouchard P, Fauser BC, Barlow DH, Palacios S, Donnez O, Bestel E, Osterloh I, Loumaye E; PEARL III and PEARL III Extension Study Group**, Long-term treatment of uterine fibroids with ulipristal acetate, *Fertil Steril* 101:1565, 2014.
  217. **Williams AR, Bergeron C, Barlow DH, Ferenczy A**, Endometrial morphology after treatment of uterine fibroids with the selective progesterone receptor modulator, ulipristal acetate, *Int J Gynecol Pathol* 31(6):556, 2012.
  218. **Lethaby A, Farquhar C, Cooke I**, Antifibrinolytics for heavy menstrual bleeding, *Cochrane Database Syst Rev* (4):CD000249, 2000.
  219. **Wellington K, Wagstaff AJ**, Tranexamic acid: a review of its use in the management of menorrhagia, *Drugs* 63:1417, 2003.
  220. **Sundstrom A, Seaman H, Kieler H, Alfredsson L**, The risk of venous thromboembolism associated with the use of tranexamic acid and other drugs used to treat menorrhagia: a case-control study using the General Practice Research Database, *Br J Obstet Gynaecol* 116:91, 2009.
  221. **Leminen H, Hurskainen R**, Tranexamic acid for the treatment of heavy menstrual bleeding: efficacy and safety, *Int J Womens Health* 4:413, 2012.
  222. **Cooper KG, Parkin DE, Garratt AM, Grant AM**, Two-year follow up of women randomised to medical management or transcervical resection of the endometrium for heavy menstrual loss: clinical and quality of life outcomes, *Br J Obstet Gynaecol* 106:258, 1999.
  223. **Goldrath MH, Fuller TA, Segal S**, Laser photovaporization of endometrium for the treatment of menorrhagia, *Am J Obstet Gynecol* 140:14, 1981.
  224. **DeCherney A, Polan ML**, Hysteroscopic management of intrauterine lesions and intractable uterine bleeding, *Obstet Gynecol* 61:392, 1983.
  225. **Vancaillie TG**, Electrocoagulation of the endometrium with the ball-end resectoscope, *Obstet Gynecol* 74:425, 1989.
  226. **Lethaby A, Shepperd S, Cooke I, Farquhar C**, Endometrial resection and ablation versus hysterectomy for heavy menstrual bleeding, *Cochrane Database Syst Rev* (2):CD000329, 2000.
  227. **Roy KH, Mattox JH**, Advances in endometrial ablation, *Obstet Gynecol Surv* 57:789, 2002.
  228. **Vilos GA**, Intrauterine surgery using a new coaxial bipolar electrode in normal saline solution (Versapoint): a pilot study, *Fertil Steril* 72:740, 1999.
  229. **Weisberg M, Goldrath MH, Berman J, Greenstein A, Krotec JW, Fronio L**, Hysteroscopic endometrial ablation using free heated saline for the treatment of menorrhagia, *J Am Assoc Gynecol Laparosc* 7:311, 2000.

230. **Meyer WR, Walsh BW, Grainger DA, Peacock LM, Loffer FD, Steege JF**, Thermal balloon and rollerball ablation to treat menorrhagia: a multicenter comparison, *Obstet Gynecol* 92:98, 1998.
231. **Grainger DA, Tjaden BL, Rowland C, Meyer WR**, Thermal balloon and rollerball ablation to treat menorrhagia: two-year results of a multicenter, prospective, randomized, clinical trial, *J Am Assoc Gynecol Laparosc* 7:175, 2000.
232. **Cooper JM, Erickson ML**, Global endometrial ablation technologies, *Obstet Gynecol Clin North Am* 27:385, 2000.
233. **Cooper J, Gimpelson R, Laberge P, Galen D, Garza-Leal JG, Scott J, Leyland N, Martyn P, Liu J**, A randomized, multicenter trial of safety and efficacy of the NovaSure system in the treatment of menorrhagia, *J Am Assoc Gynecol Laparosc* 9:418, 2002.
234. **Cooper KG, Bain C, Parkin DE**, Comparison of microwave endometrial ablation and transcervical resection of the endometrium for treatment of heavy menstrual loss: a randomised trial, *Lancet* 354:1859, 1999.
235. **Duleba AJ, Heppard MC, Soderstrom RM, Townsend DE**, A randomized study comparing endometrial cryoablation and rollerball electroablation for treatment of dysfunctional uterine bleeding, *J Am Assoc Gynecol Laparosc* 10:17, 2003.
236. **Lethaby A, Hickey M, Garry R, Penninx J**, Endometrial resection/ablation techniques for heavy menstrual bleeding, *Cochrane Database Syst Rev* (4):CD001501, 2009.
237. **Bhatia K, Doonan Y, Giannakou A, Bentick B**, A randomised controlled trial comparing GnRH antagonist cetrorelix with GnRH agonist leuprorelin for endometrial thinning prior to transcervical resection of endometrium, *Br J Obstet Gynaecol* 115:1214, 2008.
238. **Phipps JH, Lewis BV, Prior MF, Roberts T**, Experimental and clinical studies with radio frequency-induced thermal endometrial ablation for functional menorrhagia, *Obstet Gynecol* 76:876, 1990.
239. **Townsend DE, Richart RM, Paskowitz RA, Woolfork RE**, Rollerball coagulation of the endometrium, *Obstet Gynecol* 76:310, 1990.
240. **O'Connor H, Magos A**, Endometrial resection for the treatment of menorrhagia, *N Engl J Med* 335:151, 1996.
241. **Sculpher MJ, Dwyer N, Byford S, Stirrat GM**, Randomised trial comparing hysterectomy and transcervical endometrial resection: effect on health related quality of life and costs two years after surgery, *Br J Obstet Gynaecol* 103:142, 1996.
242. **Crosignani PG, Vercellini P, Apolone G, De Giorgi O, Cortesi I, Meschia M**, Endometrial resection versus vaginal hysterectomy for menorrhagia: long-term clinical and quality-of-life outcomes, *Am J Obstet Gynecol* 177:95, 1997.
243. **O'Connor H, Broadbent JA, Magos AL, McPherson K**, Medical Research Council randomised trial of endometrial resection versus hysterectomy in management of menorrhagia, *Lancet* 349:897, 1997.
244. **Zupi E, Zullo F, Marconi D, Sbracia M, Pellicano M, Solima E, Sorrenti G**, Hysteroscopic endometrial resection versus laparoscopic supracervical hysterectomy for menorrhagia: a prospective randomized trial, *Am J Obstet Gynecol* 188:7, 2003.
245. **Xia E, Li TC, Yu D, Huang X, Zheng J, Liu Y, Zhang M**, The occurrence and outcome of 39 pregnancies after 1621 cases of transcervical resection of endometrium, *Hum Reprod* 21:3282, 2006.
246. **Lo JS, Pickersgill A**, Pregnancy after endometrial ablation: English literature review and case report, *J Minim Invasive Gynecol* 13:88, 2006.
247. **Steed HL, Scott JZ**, Adenocarcinoma diagnosed at endometrial ablation, *Obstet Gynecol* 97:837, 2001.
248. **Vilos GA, Harding PG, Silcox JA, Sugimoto AK, Carey M, Ettler HC**, Endometrial adenocarcinoma encountered at the time of hysteroscopic endometrial ablation, *J Am Assoc Gynecol Laparosc* 9:40, 2002.
249. **Horowitz IR, Copas PR, Aaron M, Spann CO, McGuire WP**, Endometrial adenocarcinoma following endometrial ablation for postmenopausal bleeding, *Gynecol Oncol* 56:460, 1995.
250. **Brooks-Carter GN, Killackey MA, Neuwirth RS**, Adenocarcinoma of the endometrium after endometrial ablation, *Obstet Gynecol* 96:836, 2000.
251. **Valle RF, Baggish MS**, Endometrial carcinoma after endometrial ablation: high-risk factors predicting its occurrence, *Am J Obstet Gynecol* 179:569, 1998.

252. **Franchini M, Cianferoni L**, Emergency endometrial resection in women with acute, severe uterine bleeding, *J Am Assoc Gynecol Laparosc* 7:347, 2000.
253. **Milad MP, Valle RF**, Emergency endometrial ablation for life-threatening uterine bleeding as a result of a coagulopathy, *J Am Assoc Gynecol Laparosc* 5:301, 1998.
254. **Nichols CM, Gill EJ**, Thermal balloon endometrial ablation for management of acute uterine hemorrhage, *Obstet Gynecol* 100:1092, 2002.
255. **Osuga Y, Okagaki R, Ozaki S, Matsumi H, Fujii T, Iwase H, Taketani Y**, Successful emergency endometrial ablation for intractable uterine bleeding in a postmenopausal woman complicated with liver cirrhosis and morbid obesity, *Surg Endosc* 15:898, 2001.

---

# The Breast

The form, function, and pathology of the human female breast are major concerns of medicine and society. Mammals define our biologic class by the ability of the breast to nourish our young. As obstetricians, we seek to enhance or diminish function, and as gynecologists, the appearance of inappropriate lactation (galactorrhea), breast masses, breast pain, or changes in breast contour may signify serious disease. Cancer of the breast is the most prevalent cancer in women.

This chapter reviews the factors involved in normal growth and development of the breast, including the physiology of normal lactation, describes the numerous factors leading to inappropriate lactation, and, finally, discusses the endocrine aspects of breast cancer.

# GROWTH AND DEVELOPMENT

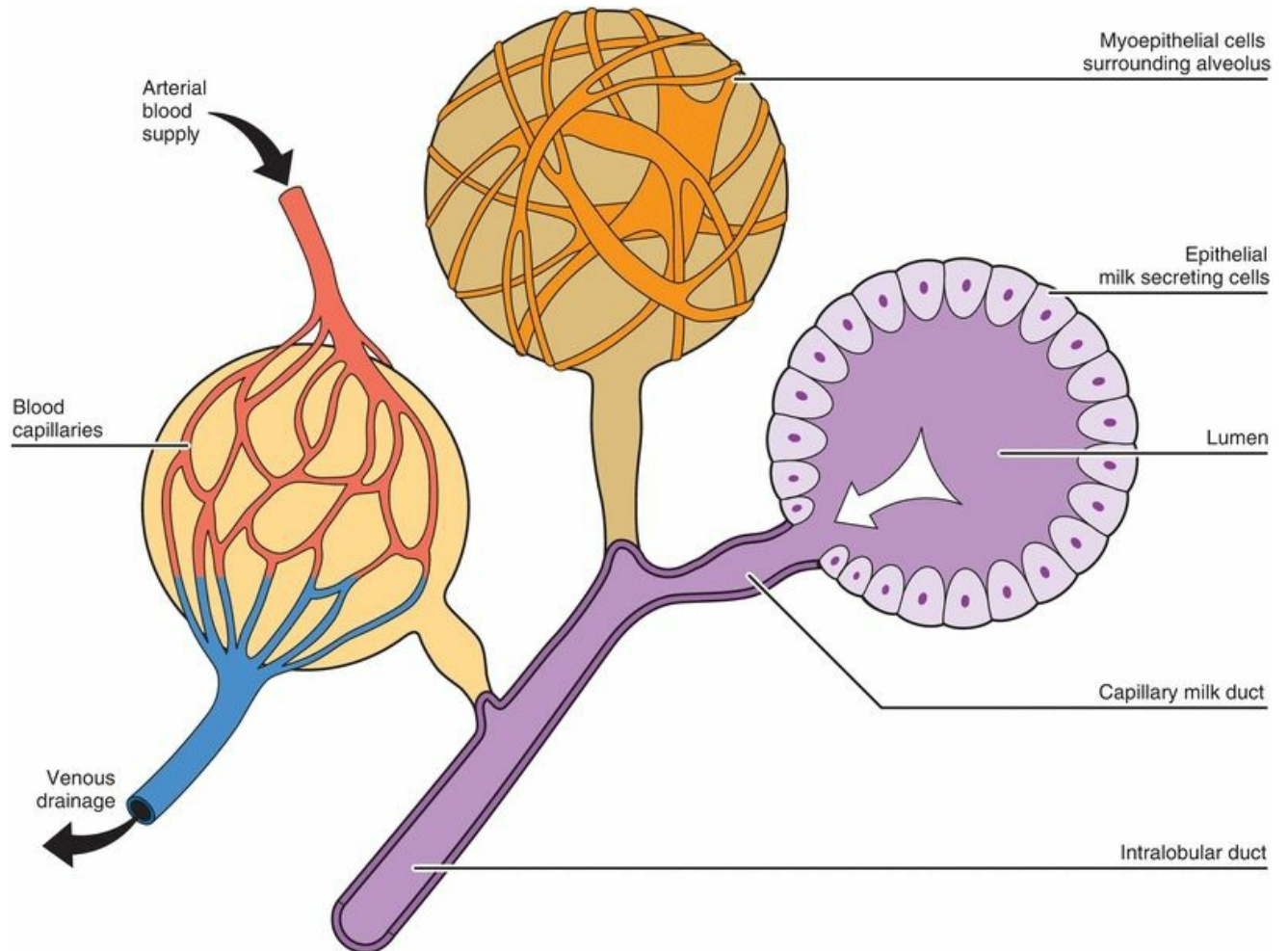
---

The basic component of the breast lobule is the hollow alveolus or milk gland lined by a single layer of milk-secreting epithelial cells, derived from an ingrowth of epidermis into the underlying mesenchyme at 10–12 weeks of gestation. Each alveolus is encased in a crisscrossing mantle of contractile myoepithelial strands and a rich capillary network.

The lumen of the alveolus connects to a collecting intralobular duct by means of a thin nonmuscular duct. There are 15–20 of these collecting intralobular ducts per breast, which are arranged radially into mammary lobules. The collecting intralobular ducts reach the exterior of the breast and are also lined by contractile muscle cells.

Growth of this milk-producing system is dependent on numerous hormonal factors that occur during embryologic development, at puberty, and then in pregnancy. Although there is considerable overlapping of hormonal influences, the differences in quantities of the stimuli in each circumstance and the availability of entirely unique inciting factors (human placental lactogen [hPL] and prolactin) during pregnancy permit this chronologic distinction. The strength of the hormonal stimulus to breast tissue during pregnancy is responsible for the fact that nearly half of the male and female newborns have breast secretions ([Figure 16.1](#)).





**FIGURE 16.1**

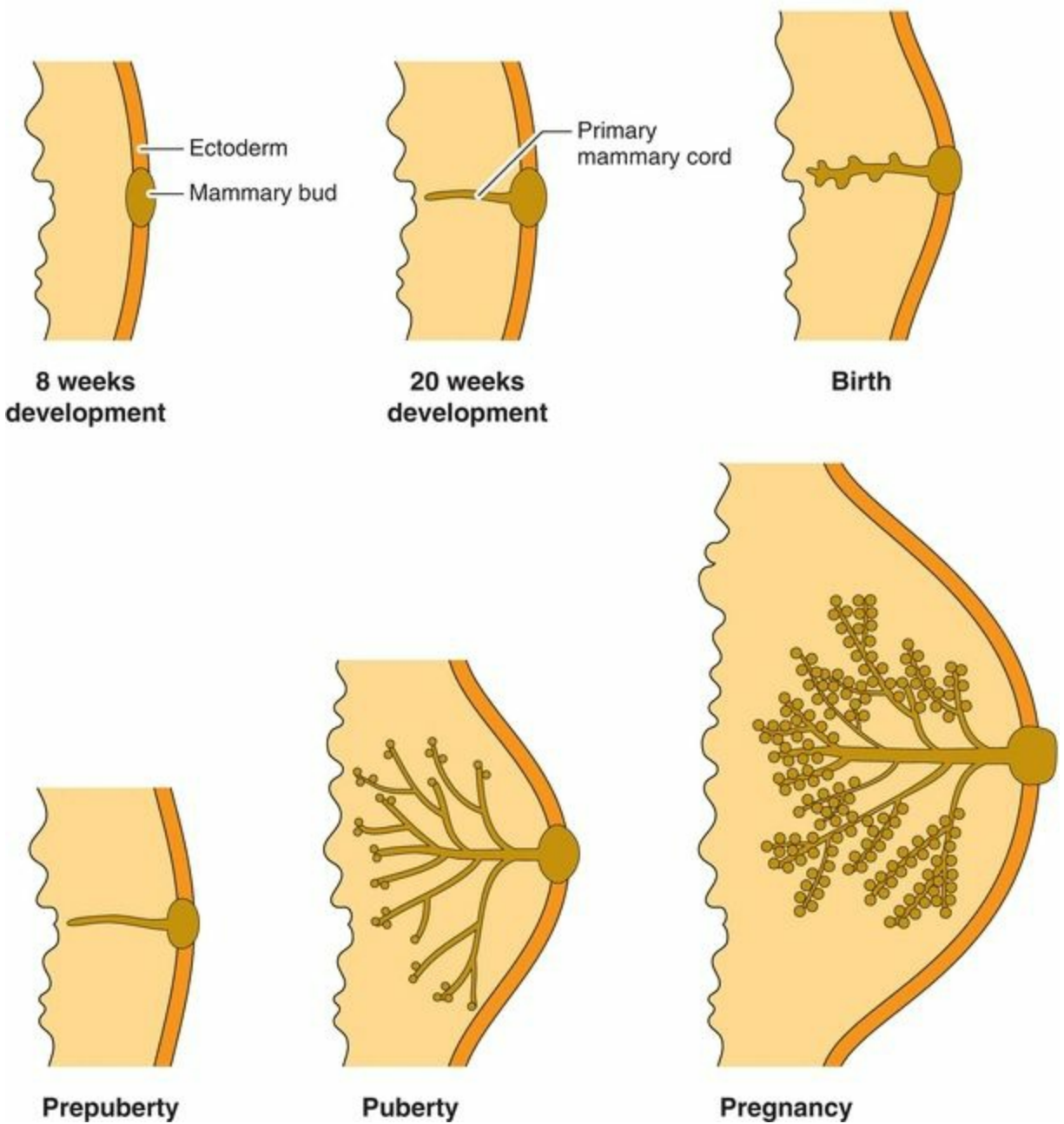
In embryologic development, the ectoderm gives rise to the epithelial component of the mammary gland and the mesoderm gives rise to the stroma. These initially form as mammary lines down the ventral surface of the embryo, resolving to one pair of placodes of mammary tissue in most humans due to complex signaling cascades from TBX3, BMP4, FGF10, Lef1, and Wnt10b.<sup>1,2</sup> These placodes descend from the surface epithelium into the underlying mesenchyme, leaving stalks of epithelium.<sup>3</sup> Once the mammary placode reaches the fat pad, the epithelium branches and lumenizes to form the rudimentary intralobular ducts. Nipple generation occurs by thickening of the epidermis and suppression of hair follicle growth, and this is regulated by parathyroid hormone–related protein.<sup>4</sup> In humans, these processes are similar in males and females.

Gender-specific breast differentiation in humans occurs at puberty. The major influences on breast growth at puberty are growth hormone as mediated by insulin-like growth factor 1 (IGF-1) and estrogen.<sup>5</sup> In most girls, the first response to the increasing levels of IGF-1, growth hormone, and estrogen is an increase in size and pigmentation

of the areola and the formation of a mass of breast tissue just underneath the areola. Breast tissue binds estrogen in a manner similar to the uterus and vagina. The human breast expresses both estrogen receptors, ER-alpha and ER-beta.<sup>6</sup> The development of estrogen receptors in the breast does not occur in the absence of prolactin. The primary effect of estrogen in subprimate mammals is to stimulate growth of the ductal portion of the gland system. Progesterone in these animals, in the presence of estrogen, influences growth of the alveolar components of the lobule that later become the milk-producing structures.<sup>7</sup> However, no hormone alone is capable of yielding optimal breast growth and development. Full differentiation of the gland requires insulin, cortisol, thyroxine, and prolactin.<sup>8</sup> Experimental evidence in mice knockout models supports the combined actions of estrogen and progesterone, mediated primarily by ER-alpha and progesterone receptor-B but dependent on epidermal growth factor and IGF-1.<sup>9,10,11,12</sup> Estrogen and progesterone receptors in normal breast tissue are located in nondividing epithelial cells and in stromal cells adjacent to proliferating epithelial cells, indicating the importance of paracrine communication using growth factors. Growth hormone–induced IGF-1 is essential in both mammary development and function.<sup>9</sup>

The pubertal response is a manifestation of closely synchronized central (hypothalamus-pituitary) and peripheral (ovary-breast) events. For example, gonadotropin-releasing hormone (GnRH) is known to stimulate prolactin release, and this action is potentiated by estrogen.<sup>13</sup> This suggests a paracrine interaction between gonadotrophs and lactotrophs, linked by estrogen, ultimately with an impact on the breast.

Changes occur routinely in response to the estrogen-progesterone sequence of a normal menstrual cycle. Maximal size of the breast occurs late in the luteal phase. Fluid secretion (**Figure 16.2**), mitotic activity, and DNA production of nonglandular tissue and glandular epithelium peak during the luteal phase.<sup>14,15,16</sup> This accounts for cystic and tender premenstrual changes.



**FIGURE 16.2**

During the normal menstrual cycle, estrogen receptors in mammary gland epithelium decrease in number during the luteal phase, whereas progesterone receptors remain at a high level throughout the cycle.<sup>17</sup> Studies using tissue from reduction mammoplasties or from breast tissue near a benign or malignant lesion have demonstrated a peak in mitotic activity during the luteal phase.<sup>15,18,19</sup> Using fine-needle biopsy tissue, an immunocytochemical marker of proliferation was higher in the luteal phase than in the proliferative phase.<sup>17</sup> And in this study, there was a direct correlation with serum progesterone levels. However, important studies indicate that with increasing duration

of exposure, progesterone imposes a limitation on breast cell proliferation.<sup>20,21,22</sup>

Final differentiation of the alveolar epithelial cell into a mature milk cell is accomplished by the gestational increase in estrogen and progesterone, combined with the presence of prolactin, but only after prior exposure to cortisol and insulin. The complete reaction depends on the availability of minimal quantities of thyroid hormone. Thus, the endocrinologically intact individual in whom estrogen, progesterone, thyroxine, cortisol, insulin, prolactin, hPL, and growth hormone are available can have appropriate breast growth and function. During the first trimester of pregnancy, growth and proliferation are maximal, changing to differentiation and secretory activity as pregnancy progresses.

Breast tissue changes with aging. During teenage years, the breasts are dense and predominantly glandular. As the years go by, the breasts contain progressively more fat, but after menopause, this process accelerates so that soon into the postmenopausal years, the breast glandular tissue is mostly replaced by fat.

# Abnormal Shape and Size

Early differentiation of the mammary gland anlage is under genetic and fetal hormonal control. Abnormalities in adult size or shape may reflect the impact of hormones (especially the presence or absence of testosterone) during this early period of development. This prenatal hormonal influence programs the breast development that will occur in response to the increase in hormones at puberty. Occasionally, the breast bud begins to develop on one side first. Similarly, one breast may grow faster than the other. These inequalities usually disappear by the time development is complete. However, exact equivalence in size may not be attained. Significant asymmetry is correctable only by a plastic surgeon. Likewise, hypoplasia and hypertrophy can be treated only by corrective surgery. Hormone therapy is ineffective in producing a permanent change in breast shape or size, with one exception, in patients with primary amenorrhea due to deficient ovarian function; estrogen treatment induces significant and gratifying breast growth. Breast size can be temporarily increased in current users of oral contraceptives, but there is no lasting effect associated with past use.<sup>23</sup>

**Accessory nipples** (almost always without underlying breast tissue) can be found anywhere from the groin to the neck, remnants of the mammary line that extends early in embryonic life (6th week) along the ventral, lateral body wall. They occur in approximately 1% of women (sporadic or familial) and require no therapy. Whether or not **polythelia** is associated with renal and urinary tract malformations is controversial.<sup>24,25,26,27,28</sup> It is recommended to investigate the renal-urinary tract by renal ultrasound in the presence of polythelia.<sup>29</sup>

**Accessory breast tissue** occurs because of incomplete embryologic regression of the mammary ridges, and for this reason, the location is along the mammary line that extends from the axilla to the pubic area. Ectopic breast tissue is usually detected during puberty, pregnancy, or lactation, a consequence of hormonally induced enlargement. Accessory breasts are commonly bilateral and occasionally are found in unusual locations such as the axilla, scapula, thigh, or labia majora, and when nipple and areola are absent, the mass can be a diagnostic dilemma.<sup>30</sup> Even when the diagnosis is obvious, surgical excision is indicated for cosmetic and comfort reasons.<sup>31</sup> Accessory breast tissue is subject to the same risk of cancer as normal breasts.

# **PREGNANCY AND LACTATION**

---

# Prolactin Secretion

In most mammalian species, prolactin is a single-chain polypeptide of 199 amino acids, 40% similar in structure to growth hormone and placental lactogen. All three hormones are believed to have originated from a common ancestral protein about 400 million years ago.

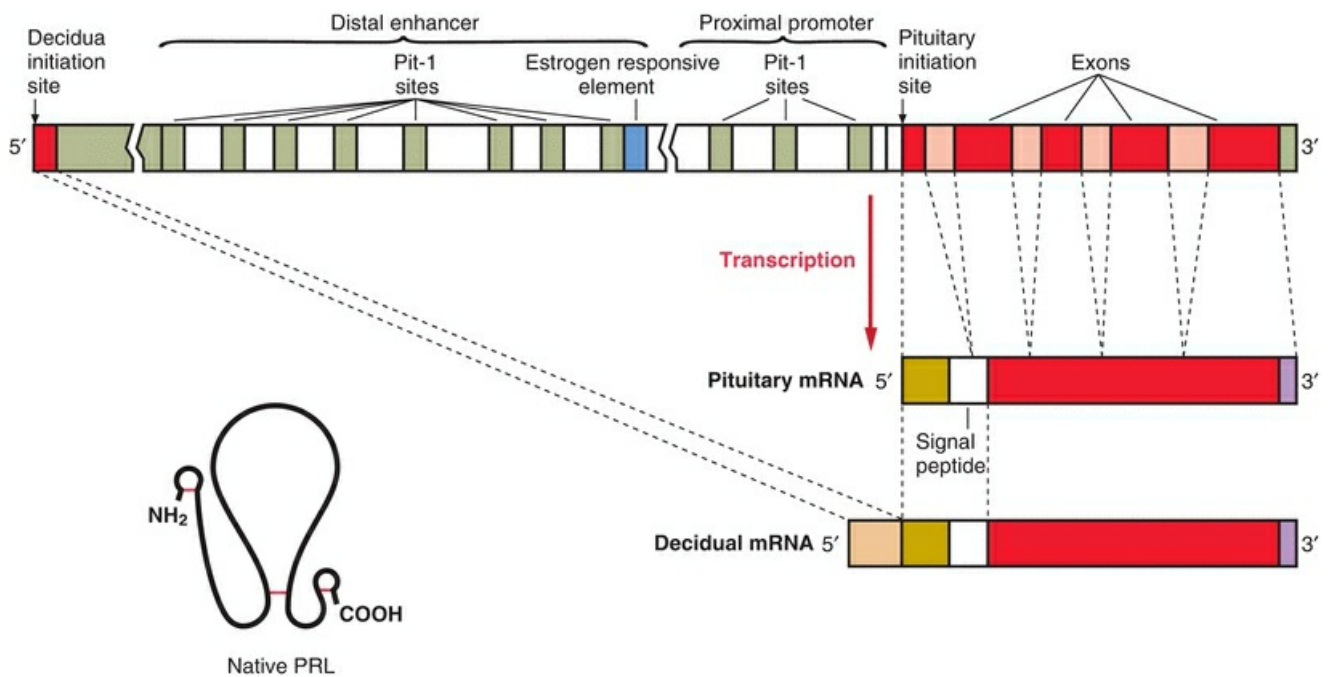
Prolactin is encoded by a single gene on chromosome 6, producing a molecule that in its major form is maintained in three loops by disulfide bonds.<sup>32</sup> Prolactin variants are the result of posttranslational modifications. Little prolactin represents a splicing variant resulting from the proteolytic deletion of amino acids. Big prolactin can result from the failure to remove introns; it has little biologic activity and does not cross-react with antibodies to the major form of prolactin. The so-called big variants of prolactin are due to separate molecules of prolactin binding to each other, either noncovalently or by interchain disulfide bonding. Some of the apparently larger forms of prolactin are prolactin molecules complexed to binding proteins. High levels of relatively inactive prolactin in the absence of a tumor can be due to the creation of macromolecules of prolactin by antiprolactin autoantibodies.<sup>33,34</sup> Overall, big prolactins account for somewhere between 10% and 25% of the hyperprolactinemia reported by commercial assays.<sup>35</sup>

Other modifications of prolactin exist, including glycosylation, phosphorylation, deamidation, and sulfation. Prolactin that has been glycosylated continues to exert activity, and other enzymatic cleavages of the prolactin molecule yield fragments that may be capable of biologic activity. Differences in the carbohydrate moieties can produce differences in biologic activity and immunoreactivity. However, the nonglycosylated form of prolactin is the predominant form of prolactin secreted into the circulation.<sup>36</sup>

**At any one point of time, the bioactivity (e.g., galactorrhea) and the immunoreactivity (circulating levels by immunoassay) of prolactin represent the cumulative effect of the family of structural variants. Remember, immunoassays do not always reflect the biologic situation (e.g., a normal prolactin level in a woman with galactorrhea). The routine radioimmunoassay of prolactin is generally clinically reliable, especially at extremely high levels associated with prolactin-secreting pituitary tumors.**

The anterior pituitary cells that produce prolactin, growth hormone, and thyroid-stimulating hormone (TSH; lactotrophs, somatotrophs, and thyrotrophs) require the presence of Pit-1, a transcription factor, for transactivation. Pit-1 binds to the prolactin gene in multiple sites in both the promoter region and in an adjacent region, designated as a distal enhancer; Pit-1 binding is a requirement for prolactin promoter activity and

gene transcription. Many hormones, neurotransmitters, and growth factors influence the prolactin gene, involved in a level of function beyond that allowed by Pit-1. Fundamental modulation of prolactin secretion is exerted by estrogen, producing both differentiation of lactotrophs and direct stimulation of prolactin production.<sup>37,38</sup> An estrogen response element is adjacent to one of the Pit-1 binding sites in the distal enhancer region, and estrogen stimulation of the prolactin gene involves interaction with this Pit-1 binding site. Estrogen additionally influences prolactin production by suppressing dopamine secretion.<sup>39</sup> Prolactin is also synthesized in extrapituitary tissues, including breast tissue and endometrial decidua.<sup>40</sup> In extrapituitary sites, the active promoter site is upstream of the pituitary initiation site and is not regulated by Pit-1, estrogens, or dopamine. Progesterone increases prolactin secretion in the decidua but has no effect in the pituitary (**Figure 16.3**).



**FIGURE 16.3**

Prolactin is involved in many biochemical events during pregnancy. Surfactant synthesis in the fetal lung is influenced by prolactin, and decidual prolactin modulates prostaglandin-mediated uterine muscle contractility.<sup>41,42</sup> Prolactin also contributes to the prevention of the immunologic rejection of the conceptus by suppressing the maternal immune response. Prolactin is both produced and processed in breast cells. The mechanisms and purpose for mammary production of prolactin remain to be determined, but prolactin in milk is believed to be derived from local synthesis. Transmission of this prolactin to the newborn may be important for immune functions.



# Prolactin-Inhibiting Dopamine

The basal hypothalamus maintains suppression of pituitary prolactin secretion by delivering dopamine, a prolactin-inhibiting factor (PIF), to the anterior pituitary via the portal circulation. Suckling suppresses the formation of dopamine.<sup>43</sup> Dopamine binds specifically to lactotroph cells and suppresses the secretion of prolactin into the general circulation; in its absence, prolactin is secreted. Dopamine binds to a G-protein-coupled receptor ([Chapter 2](#)) that exists in a long form and a short form, but only the D<sub>2</sub> (long form) is present on lactotrophs. There are several other PIFs, but a specific role has been established only for dopamine.

# Prolactin-Releasing Factor

Prolactin secretion may also be influenced by a positive hypothalamic factor, prolactin-releasing factor (PRF). PRF does exist in various birds. The identity of this material has not been elucidated or its function substantiated in normal human physiology. It is believed that most prolactin secretagogues work by inhibiting dopamine secretion, including thyrotropin-releasing hormone (TRH), growth factors, vasopressin, and oxytocin.<sup>44</sup> TRH stimulation of prolactin release involves calcium mechanisms (both internal release and influx via calcium channels) in response to the TRH receptor, also a member of the G-protein family. However, except in hypothyroidism, normal physiologic changes as well as abnormal prolactin secretion are easily explained and understood in terms of variations in the PIF, dopamine.

# The Prolactin Receptor

The prolactin receptor is encoded by a gene on chromosome 5p13–14 that is near the gene for the growth hormone receptor. The prolactin receptor belongs to a receptor family that includes many cytokines and some growth factors, supporting a dual role for prolactin as a classic hormone and as a cytokine.<sup>32</sup>

Prolactin receptors exist in more than one form, all containing an extracellular region, a single transmembrane region, and a relatively long cytoplasmic domain. There is evidence for more than one receptor, depending on the site of action (e.g., decidua and placenta).<sup>45</sup> The similar amino acid identity between prolactin and growth hormone receptors is approximately 30%, with certain regions having up to 70% homology.<sup>46</sup> Prolactin receptors are expressed in many tissues throughout the body. Because of the various forms and functions of prolactin, it is likely that multiple signal mechanisms are involved, and for that reason, no single second messenger for prolactin's intracellular action has been identified. A protein also exists that functions as a receptor/transporter, translocating prolactin from the blood into the cerebrospinal fluid, the amniotic fluid, and milk.

# Amniotic Fluid Prolactin

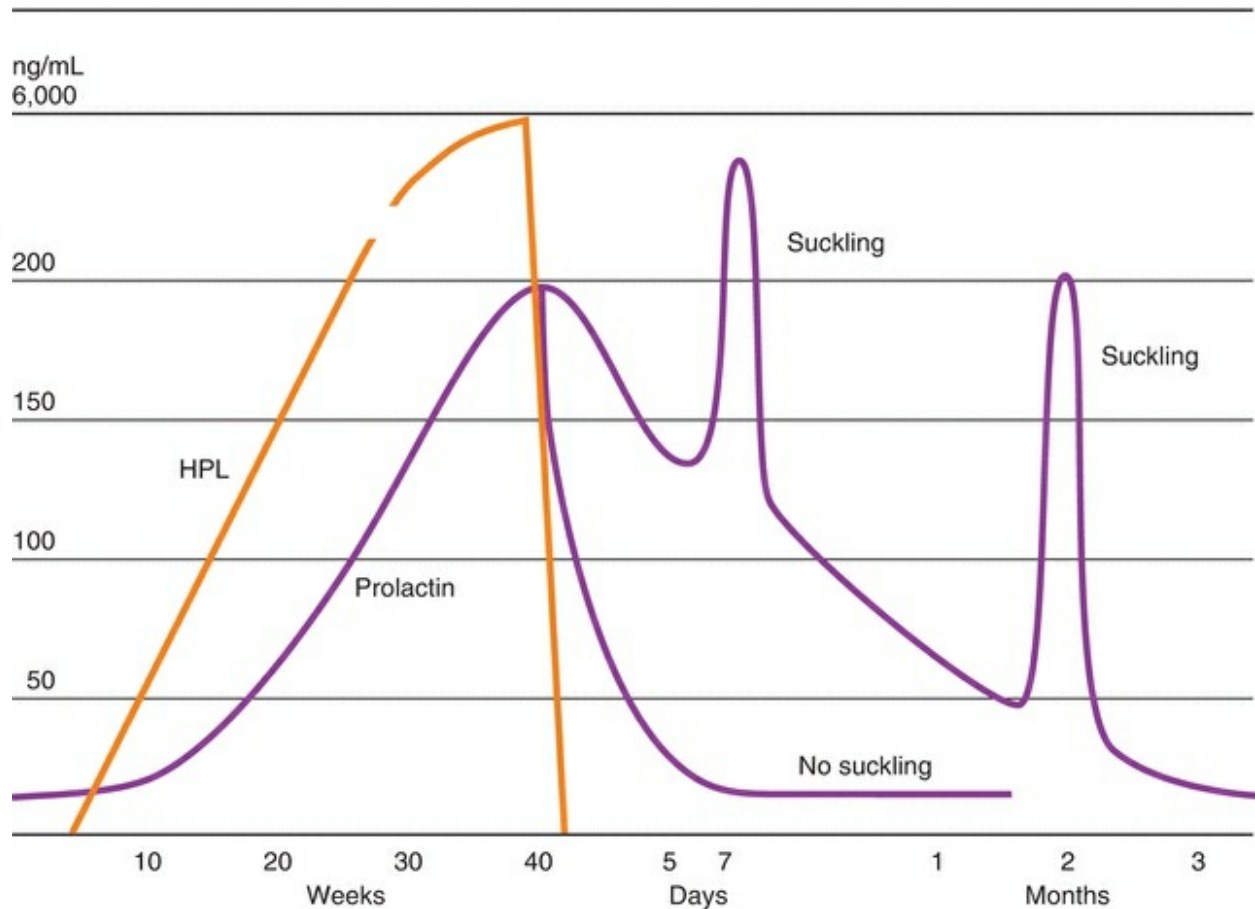
Amniotic fluid concentrations of prolactin parallel maternal serum concentrations until the 10th week of pregnancy, rise markedly until the 20th week, and then decrease. Maternal prolactin does not pass to the fetus in significant amounts. Indeed, the source of amniotic fluid prolactin is neither the maternal pituitary nor the fetal pituitary. The failure of dopamine agonist treatment to suppress amniotic fluid prolactin levels, and studies with in vitro culture systems indicate a primary decidual source with transfer via amnion receptors to the amniotic fluid, requiring the intactness of amnion, chorion, and adherent decidua. This decidual synthesis of prolactin is initiated by progesterone, but once decidualization is established, prolactin secretion continues in the absence of both progesterone and estradiol.<sup>47</sup> Various decidual factors regulate prolactin synthesis and release, including relaxin, insulin, and IGF-1. Prolactin produced in extrapituitary sites involves an alternative exon upstream of the pituitary start site, generating a slightly larger RNA transcript compared with the pituitary product. However, the amino acid sequence and the chemical and biologic properties of decidual prolactin are identical to those of pituitary prolactin. It is hypothesized that amniotic fluid prolactin plays a role in modulating electrolyte economy not unlike its ability to regulate sodium transport and water movement across the gills in fish (allowing the ocean-dwelling salmon and steelhead to return to freshwater streams for reproduction). Thus, prolactin would protect the human fetus from dehydration by control of salt and water transport across the amnion. Prolactin reduces the permeability of the human amnion in the fetal to maternal direction by a receptor-mediated action on the epithelium lining the fetal surface.<sup>48</sup> Decidual and amniotic fluid prolactin levels are lower in hypertensive pregnancies and in patients with polyhydramnios.<sup>49,50</sup> Prolactin receptors are present in the chorion laeve, and their concentration is lower in patients with polyhydramnios.<sup>51</sup> Thus, idiopathic polyhydramnios may be a consequence of impaired prolactin regulation of amniotic fluid.

# Lactation

During pregnancy, prolactin levels rise from the normal level of 10–25 ng/mL to high concentrations, beginning about 8 weeks and reaching a peak of 200–400 ng/mL at term.<sup>52,53</sup> The increase in prolactin parallels the increase in estrogen beginning at 7–8 weeks' gestation, and the mechanism for increasing prolactin secretion (discussed in [Chapter 7](#)) is believed to be estrogen suppression of the hypothalamic dopamine, as well as direct stimulation of prolactin gene transcription in the pituitary.<sup>54,55</sup> There is marked variability in maternal prolactin levels in pregnancy, with pulsatile secretion and a diurnal variation similar to that found in nonpregnant subjects. The peak level occurs 4–5 hours after the onset of sleep.<sup>56</sup>

Made by the placenta and actively secreted into the maternal circulation from the 6th week of pregnancy, hPL rises progressively, reaching a level of approximately 6,000 ng/mL at term. hPL, though displaying less activity than prolactin, is produced in such large amounts that it may exert a lactogenic effect.

Although prolactin stimulates significant breast growth, and is available for lactation, only colostrum (composed of desquamated epithelial cells and transudate) is produced during gestation. Full lactation is inhibited by progesterone, which interferes with prolactin action at the alveolar cell prolactin receptor level. Both estrogen and progesterone are necessary for the expression of the lactogenic receptor, but progesterone antagonizes the positive action of prolactin on its own receptor, while progesterone and pharmacologic amounts of androgens reduce prolactin binding.<sup>46,57,58</sup> In mice, progesterone stimulates a corepressor that blocks the promoter region of the casein milk protein gene, thus inhibiting transcription.<sup>59</sup> After delivery, the loss of progesterone leads to a decrease in the inhibitory peptide. The effective use of high doses of estrogen to suppress postpartum lactation indicates that pharmacologic amounts of estrogen also block prolactin action ([Figure 16.4](#)).



**FIGURE 16.4**

The principal hormone involved in milk biosynthesis is prolactin. Without prolactin, synthesis of lactose, lipids, and the primary protein, casein, will not occur, and true milk secretion will be impossible. The hormonal trigger for initiation of milk production within the alveolar cell and its secretion into the lumen of the gland is the rapid disappearance of estrogen and progesterone from the circulation after delivery. The clearance of prolactin is much slower, requiring 7 days to reach nonpregnant levels in a nonbreastfeeding woman. These discordant hormonal events result in removal of the estrogen and progesterone inhibition of prolactin action on the breast. Breast engorgement and milk secretion begin 3–4 days postpartum when the sex steroids have been sufficiently cleared. Maintenance of steroidal inhibition or rapid reduction of prolactin secretion (with a dopamine agonist) is effective in preventing postpartum milk synthesis and secretion. Augmentation of prolactin (by domperidone, metoclopramide, TRH, or sulpiride; all dopamine receptor blockers) results in increased milk yield.<sup>60</sup>

In the first postpartum week, prolactin levels in breastfeeding women decline approximately 50% (to about 100 ng/mL). Suckling elicits increases in prolactin, which is important in initiating milk production. Until 2–3 months postpartum, basal levels are approximately 40–50 ng/mL, and there are large (about 10–20-fold) increases after

suckling. Throughout breastfeeding, baseline prolactin levels remain elevated, and suckling produces a twofold increase that is essential for continuing milk production.<sup>61,62</sup> The pattern or values of prolactin levels do not predict the postpartum duration of amenorrhea or infertility.<sup>63</sup> The failure to lactate within the first 7 days postpartum may be the first sign of Sheehan syndrome (hypopituitarism following intrapartum infarction of the pituitary gland).

Maintenance of milk production at high levels is dependent on the joint action of both anterior and posterior pituitary factors. By mechanisms to be described in detail shortly, suckling causes the release of both prolactin and oxytocin as well as TSH.<sup>64,65</sup> Prolactin sustains the secretion of casein, fatty acids, and lactose and the volume of secretion, while oxytocin contracts myoepithelial cells and empties the alveolar lumen, thus enhancing further milk secretion and alveolar refilling. The increase in TSH with suckling suggests that TRH may play a role in the prolactin response to suckling. The optimal quantity and quality of milk are dependent upon the availability of thyroid, insulin and the insulin-like growth factors, cortisol, and the dietary intake of nutrients and fluids.

Secretion of calcium into the milk of lactating women approximately doubles the daily loss of calcium.<sup>66,67</sup> In women who breastfeed for 6 months or more, this is accompanied by significant bone loss even in the presence of a high calcium intake.<sup>68</sup> However, bone density rapidly returns to baseline levels in the 6 months after weaning.<sup>69,70</sup> The bone loss is due to increased bone resorption, probably secondary to the relatively low estrogen levels associated with lactation. It is possible that recovery is impaired in women with inadequate calcium intake; total calcium intake during lactation should be at least 1,500 mg/day. Nevertheless, calcium supplementation has no effect on the calcium content of breast milk or on bone loss in lactating women who have normal diets.<sup>71</sup> In addition, fetuses and lactating mothers, except in unusual circumstances, do not suffer from a significant deficiency in vitamin D.<sup>72</sup> Furthermore, studies indicate that any loss of calcium and bone associated with lactation is rapidly restored, and therefore, there is no impact on the risk of postmenopausal osteoporosis.<sup>73,74,75,76,77</sup> Rarely, a pregnant woman can present with osteoporosis and vertebral fractures, probably a consequence of very inadequate calcium intake and severe vitamin D deficiency.<sup>78</sup> Case reports of pregnancy-associated osteoporosis indicate that this acute condition can be successfully treated with either bisphosphonates or teriparatide, the parathyroid hormone fragment.<sup>79,80</sup>

Antibodies are present in breast milk and contribute to the health of an infant. Besides the proteins, carbohydrates, and fats that provide a complete and balanced diet, human milk prevents infections in infants both by transmission of immunoglobulins and

by modifying the bacterial flora of the infant's gastrointestinal tract. Viruses can be transmitted through breast milk; however, women infected with hepatitis B may breastfeed if the child is immunized with HBIG passive prophylaxis and vaccine active prophylaxis.<sup>81</sup> Women infected with hepatitis A and C or cytomegalovirus may breastfeed if following routine hygienic precautions. Women with human immunodeficiency viruses and active herpetic outbreaks on the breasts are advised not to breastfeed. Vitamin A, vitamin B<sub>12</sub>, and folic acid are significantly reduced in the breast milk of women with poor dietary intake. As a general rule, approximately 1% of any drug ingested by the mother appears in breast milk. Prolonged breastfeeding has many health benefits for both the mother and infant, including lowered risk of maternal breast cancer, ovarian cancer, diabetes, hypertension, and heart disease and lowered risk of infant infectious disease, sudden infant death syndrome, and metabolic disease including diabetes and obesity in childhood.

Frequent emptying of the lumen is important for maintaining an adequate level of secretion. Indeed, after the fourth postpartum month, suckling appears to be the only stimulant required; however, environmental and emotional states also are important for continued alveolar activity. Vigorous aerobic exercise does not affect the volume or composition of breast milk, and therefore, infant weight gain is normal.<sup>82</sup> Maternal diet and hydration have little impact on lactation; the primary control of milk output is under the control of the infant's suckling.<sup>83</sup>

Suckling studied with ultrasonography indicates that the infant's instinctive attachment to a nipple immediately establishes a vacuum seal.<sup>84</sup> The tongue moves up and down, increasing the vacuum and producing milk flow during the downward motion. However, the ejection of milk from the breast does not occur only as the result of a mechanically induced negative pressure produced by suckling. Tactile sensors concentrated in the areola activate, via thoracic sensory nerve roots 4, 5, and 6, an afferent sensory neural arc that stimulates the paraventricular and supraoptic nuclei of the hypothalamus to synthesize and transport oxytocin to the posterior pituitary. The efferent arc (oxytocin) is blood-borne to the breast alveolus-ductal systems to contract myoepithelial cells and empty the alveolar lumen. Milk contained in major ductal repositories is ejected from 15–20 openings in the nipple. This rapid release of milk is called "letdown." This important role for oxytocin is evident in knockout mice lacking oxytocin who undergo normal parturition but fail to nurse their offspring.<sup>85</sup> The milk ejection reflex involving oxytocin is present in all species of mammals. Oxytocin-like peptides exist in fish, reptiles, and birds, and a role for oxytocin in maternal behavior may have existed before lactation evolved.<sup>83</sup>

In many instances, the activation of oxytocin release leading to letdown does not require initiation by tactile stimuli. The central nervous system can be conditioned to



respond to the presence of the infant, or to the sound of the infant's cry, by inducing activation of the efferent arc. These messages are the result of many stimulating and inhibiting neurotransmitters. Suckling, therefore, acts to refill the breast by activating both portions of the pituitary (anterior and posterior) causing the breast to produce new milk and to eject milk. The release of oxytocin is also important for uterine contractions that contribute to involution of the uterus.

The oxytocin effect is a release phenomenon acting on secreted and stored milk. Prolactin must be available in sufficient quantities for continued secretory replacement of ejected milk. This requires the transient increase in prolactin associated with suckling. The amount of milk produced correlates with the amount removed by suckling. The breast can store milk for a maximum of 48 hours before production diminishes.

# Breastfeeding by Adopting Mothers

Adopting mothers occasionally request assistance in initiating lactation.<sup>86</sup> Successful breastfeeding can be achieved by ingestion of 25-mg chlorpromazine t.i.d. or metoclopramide 10 mg t.i.d. together with vigorous nipple stimulation using a breast pump every 3–4 hours.<sup>87</sup> Milk production will not appear for several weeks. This preparation ideally should begin about a month before the expected baby is due. Stasis of milk within the breast, without stimulation, will lead to cessation of lactation. Once adequate lactation is established, drug treatment should be discontinued, tapering the dose over 3 weeks.

# Cessation of Lactation

Lactation can be terminated by discontinuing suckling. The primary effect of this cessation is loss of milk letdown via the neural evocation of oxytocin. With passage of a few days, the swollen alveoli depress milk formation probably via a local pressure effect (although milk itself may contain inhibitory factors). With resorption of fluid and solute, the swollen engorged breast diminishes in size in a few days. In addition to the loss of milk letdown, the absence of suckling reactivates dopamine production so that there is less prolactin stimulation of milk secretion. Routine use of a dopamine agonist for suppression of lactation is not recommended because of reports of hypertension, seizures, myocardial infarctions, and strokes associated with its postpartum use.

# Contraceptive Effect of Lactation

A moderate contraceptive effect accompanies lactation and produces child spacing, which is very important in the developing world as a means of limiting family size. The contraceptive effectiveness of lactation depends on the intensity of suckling, the extent to which supplemental food is added to the infant diet, and the level of nutrition of the mother (if low, the longer the contraceptive interval; however, well-nourished and undernourished women resume ovulating at the same time postpartum<sup>88</sup>). If suckling intensity or frequency is diminished, contraceptive effect is reduced. Only amenorrheic women who exclusively breastfeed at least every hour, including nighttime, during the first 6 months have the contraceptive protection equivalent to that provided by oral contraception (98% efficacy); with menstruation or after 6 months, the chance of ovulation increases.<sup>89,90</sup> With full or nearly full breastfeeding, approximately 70% of women remain amenorrheic through 6 months and only 37% through 1 year; nevertheless, with exclusive breastfeeding, the contraceptive efficacy at 1 year is high, at 92%.<sup>90</sup> Fully breastfeeding women commonly have some vaginal bleeding or spotting in the first 8 postpartum weeks, but this bleeding is not due to ovulation.<sup>91</sup>

Supplemental feeding increases the chance of ovulation (and pregnancy) even in amenorrheic women.<sup>92</sup> Total protection is achieved by the exclusively breastfeeding woman for a duration of only 10 weeks.<sup>91</sup> Half of women studied who are not fully breastfeeding ovulate before the 6th week, the time of the traditional postpartum visit; a visit during the third postpartum week is strongly recommended for contraceptive counseling (Table 16.1).

**TABLE 16.1 Rule of 3s for Postpartum Initiation of Contraception**

Full breastfeeding	Begin in <i>3rd postpartum month</i>
Partial or no breastfeeding	Begin in <i>3rd postpartum week</i>

In nonbreastfeeding women, gonadotropin levels remain low during the early puerperium and return to normal concentrations during the 3rd to 5th week when

prolactin levels have returned to normal. In an assessment of this important physiologic event (in terms of the need for contraception), the mean delay before first ovulation was found to be approximately 45 days, while no woman ovulated before 25 days after delivery.<sup>89</sup> Half of women studied ovulated before the 6th postpartum week, underscoring the need to move the traditional postpartum medical visit to the 3rd week after delivery. In women who do receive dopamine agonist treatment at or immediately after delivery, return of ovulation is slightly accelerated, and contraception is required a week earlier, in the 2nd week postpartum.<sup>93,94</sup>

Prolactin concentrations are increased in response to the repeated suckling stimulus of breastfeeding.<sup>95</sup> Given sufficient intensity and frequency, prolactin levels remain elevated. Under these conditions, follicle-stimulating hormone (FSH) concentrations are in the low normal range (having risen from extremely low concentrations at delivery to follicular range in the 3 weeks postpartum), and luteinizing hormone (LH) values are also in the low normal range. Low levels of gonadotropins do not allow the ovary to display follicular development and secrete estrogen. Therefore, vaginal dryness and dyspareunia are commonly reported by breastfeeding women. **The use of vaginal estrogen preparations is discouraged because absorption of the estrogen can lead to inhibition of milk production. Vaginal lubricants should be used until ovarian function and estrogen production return.**

The mechanism of the contraceptive effect is of interest because a similar interference with normal pituitary-gonadal function is seen with elevated prolactin levels in nonpregnant women with breast milk production and amenorrhea. Earlier experimental evidence suggested that the ovaries might be refractory to gonadotropin stimulation while prolactin levels are high enough to produce galactorrhea.<sup>96</sup> Prolactin appears to affect granulosa cell function in vitro by inhibiting the synthesis of progesterone. It also may change the testosterone/dihydrotestosterone ratio, thereby reducing aromatizable substrate and increasing local antiestrogen concentrations. Nevertheless, a direct effect of prolactin on ovarian follicular development does not appear to be a major factor.

The alternative and predominant contraceptive mechanism is central. Elevated levels of prolactin inhibit the pulsatile secretion of GnRH.<sup>97,98</sup> Prolactin excess has short-loop positive feedback effects on dopamine. Increased dopamine reduces GnRH by suppressing arcuate nucleus function, perhaps in a mechanism mediated by endogenous opioid activity.<sup>99,100</sup> However, blockade of dopamine receptors with a dopamine antagonist or the administration of an opioid antagonist in breastfeeding women does not always affect gonadotropin secretion.<sup>101</sup> The exact mechanism for the suppression of GnRH secretion remains to be fully identified. The principle of GnRH suppression by prolactin is reinforced by the demonstration that treatment of

amenorrheic, lactating women with pulsatile GnRH fully restores pituitary secretion and normal ovarian cyclic activity.<sup>102</sup>

At weaning, as prolactin blood concentrations fall to normal, gonadotropin levels increase, and estradiol secretion rises. This prompt resumption of ovarian function is followed by the occurrence of ovulation within 14–30 days of weaning.

# INAPPROPRIATE

# LACTATION:

## GALACTORRHEA SYNDROMES

---

Galactorrhea refers to the mammary secretion of a milky fluid, which is nonphysiologic in that it is inappropriate (not immediately related to pregnancy or the needs of a child), persistent, and sometimes excessive. Although usually white or clear, the color may be yellow or even green. In the latter circumstance, local breast disease should be considered. To elicit breast secretion, pressure should be applied to all sections of the breast beginning at the base of the breast and working up toward the nipple. Galactorrhea can involve both breasts or just one breast. **Hormonally induced secretions usually come from multiple duct openings in contrast to pathologic discharge that usually comes from a single duct.** A bloody discharge is more typical of cancer. The quantity of secretion is not an important criterion. Amenorrhea does not necessarily accompany galactorrhea, even in the most serious provocative disorders. Any galactorrhea demands evaluation in a nulliparous woman or if at least 12 months has elapsed since the last pregnancy or weaning in a parous woman. This recommendation has evolved empirically, knowing that many women have the persistence of galactorrhea for many months after breastfeeding, and therefore, there is room for clinical judgment.

# Differential Diagnosis of Galactorrhea

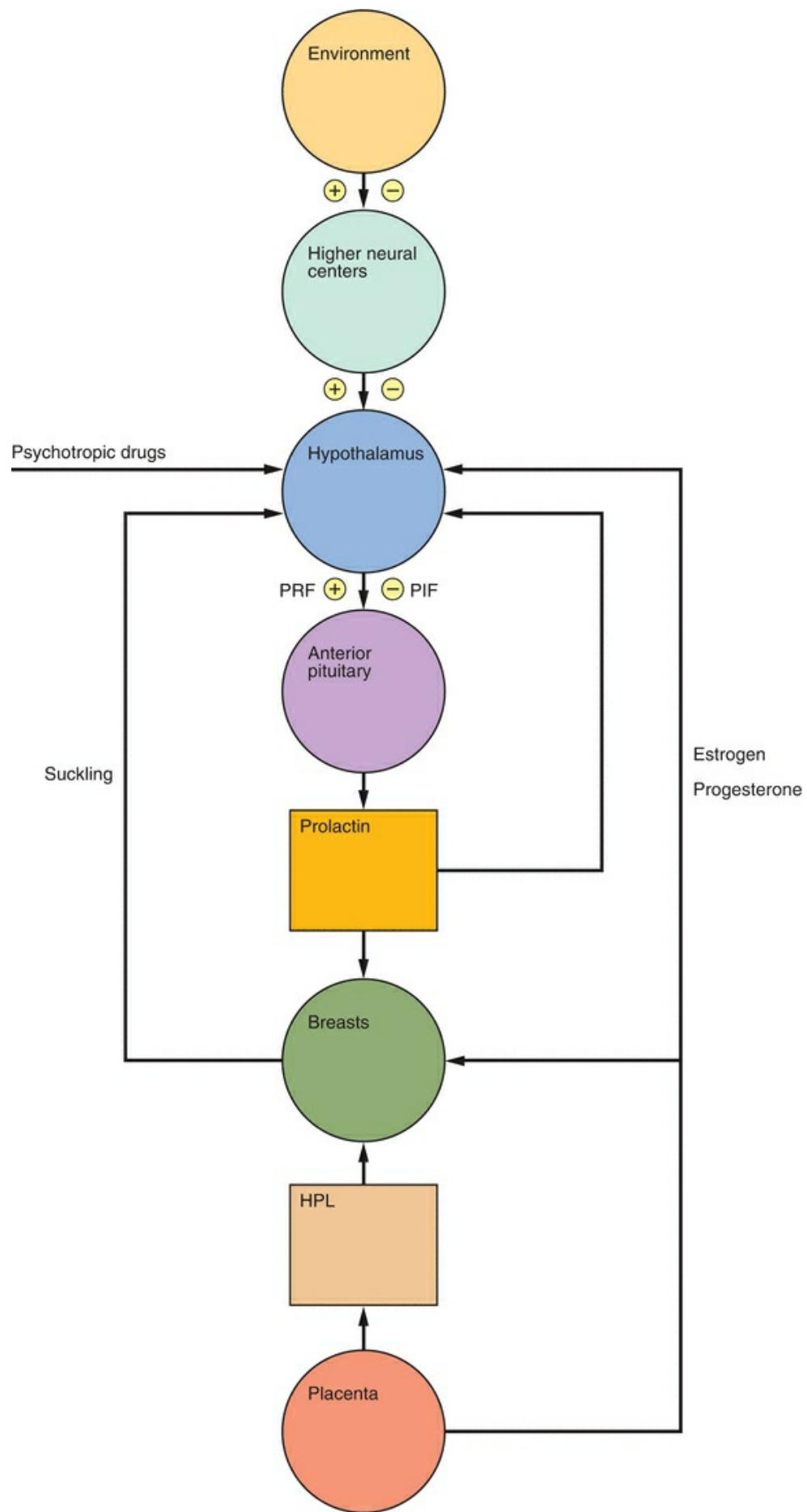
The differential diagnosis of galactorrhea is a complex clinical challenge. The difficulty arises from the multiple factors involved in the control of prolactin release. In most pathophysiologic states, the final common pathway leading to galactorrhea is an inappropriate augmentation of prolactin release. The following considerations are important:

1. Increased prolactin release can be a consequence of prolactin elaboration and secretion from pituitary tumors (discussed in [Chapter 10](#)), which function independently of the otherwise appropriate restraints exerted by PIFs from a normally functioning hypothalamus. This infrequent but potentially dangerous tumor, which has endocrine, neurologic, and ophthalmologic liabilities that can be disabling, makes the differential diagnosis of persistent galactorrhea a major clinical challenge. Beyond producing prolactin, the tumor may also suppress pituitary parenchyma by expansion and compression, interfering with the secretion of other tropic hormones. Other pituitary tumors may be associated with lactotroph hyperplasia and present with the characteristic syndrome of hyperprolactinemia and amenorrhea.
2. A variety of drugs can inhibit hypothalamic dopamine.<sup>103</sup> There are nearly 100 phenothiazine derivatives with indirect mammatropic activity. In addition, there are many phenothiazine-like compounds, reserpine derivatives, amphetamines, and an unknown variety of other drugs (opiates, diazepam, butyrophenones, verapamil,  $\alpha$ -methyldopa, and tricyclic antidepressants) that can initiate galactorrhea via hypothalamic suppression. The final action of these compounds is either to deplete dopamine levels or to block dopamine receptors. Chemical features common to many of these drugs are an aromatic ring with a polar substituent as in estrogen and at least two additional rings or structural attributes making spatial arrangements similar to estrogen. Thus, these compounds may act in a manner similar to estrogens to decrease dopamine and/or to act directly on the pituitary. In support of this conclusion, it has been demonstrated that estrogen and phenothiazine derivatives compete for the same receptors in the median eminence. Prolactin is uniformly elevated in patients on therapeutic amounts of these drugs, but essentially never as high as 100 ng/mL. Approximately 30–50% exhibit galactorrhea that should not persist beyond 3–6 months after drug treatment is discontinued.
3. Hypothyroidism (juvenile or adult) can be associated with galactorrhea. With diminished circulating levels of thyroid hormone, hypothalamic TRH is produced in excess and acts as a PRF to release prolactin from the pituitary. Reversal with thyroid hormone is strong circumstantial evidence to support the conclusion that



TRH stimulates prolactin.

4. Excessive estrogen (e.g., oral contraceptives) can lead to milk secretion via hypothalamic suppression, causing reduction of dopamine and release of pituitary prolactin, and direct stimulation of the pituitary lactotrophs. Galactorrhea developing during oral contraceptive administration may be most noticeable in the traditional dosing regimen during the 7 days free of medication (when the steroids are cleared from the body and the prolactin interfering action of the estrogen and progestin on the breast wanes). Galactorrhea caused by excessive estrogen disappears within 3–6 months after discontinuing medication. This is now a rare occurrence with the lower-dose pills.<sup>104</sup> A longitudinal study of 126 women did demonstrate a 22% increase in prolactin values over mean control levels, but the response to low-dose oral contraceptives was not out of the normal range.<sup>105</sup>
5. Prolonged intensive suckling can also release prolactin, via hypothalamic reduction of dopamine. Similarly, thoracotomy scars, cervical spinal lesions, eczema, and herpes (**Figure 16.5**) zoster can induce prolactin release by activating the afferent sensory neural arc, thereby simulating suckling. Galactorrhea and elevated prolactin levels have been observed secondary to nipple piercing.<sup>106</sup>
6. Stresses can inhibit hypothalamic dopamine, thereby inducing prolactin secretion and galactorrhea. Trauma, surgical procedures, and anesthesia can be seen in temporal relation to the onset of galactorrhea.
7. Hypothalamic lesions, stalk lesions, or stalk compression (events that physically reduce production or delivery of dopamine to the pituitary) allow release of excess prolactin leading to galactorrhea.
8. Increased prolactin concentrations can result from nonpituitary sources such as lung, ovarian, and renal tumors and even a uterine leiomyoma. Severe renal disease requiring hemodialysis is associated with elevated prolactin levels due to the decreased glomerular filtration rate.



## FIGURE 16.5

# The Clinical Problem of Galactorrhea

A variety of eponymic designations were applied in the past to variants of the lactation syndromes based on the presence of an intrasellar tumor or antecedent pregnancy. Currently, categorization of individual cases according to these eponymic guidelines neither is helpful nor does it permit discrimination of patients who have serious intrasellar or suprasellar pathology.

Galactorrhea and hyperprolactinemia are not completely correlated. The reported incidence of women with hyperprolactinemia displaying galactorrhea is about 33%. The disparity may be due partially to the variable zeal with which the presence of nipple milk secretion is sought during physical examination, the usually accompanying hypoestrogenic state, or heterogeneity of tropic hormones ([Chapter 1](#)). The immunoassay for prolactin may not discriminate among heterogeneous molecules of prolactin. A high circulating level of prolactin may not represent material capable of interacting with breast prolactin receptors. On the other hand, galactorrhea can be seen in women with normal prolactin serum concentrations. Episodic fluctuations and sleep increments may account for this clinical discordance, or in this case, bioactive prolactin may be present that is immunoreactive not detectable. Remember that at any one point in time, the bioactivity (galactorrhea) and the immunoreactivity (immunoassay result) of prolactin represent the cumulative effect of the family of structural and molecular prolactin variants present in the circulation.

Hyperprolactinemia or galactorrhea may be associated with a variety of menstrual cycle disturbances: corpus luteum insufficiency (luteal phase defect), oligoovulation, as well as amenorrhea. About one-third of women with secondary amenorrhea have elevated prolactin concentrations. Pathologic hyperprolactinemia inhibits the pulsatile secretion of GnRH, and the reduction of circulating prolactin levels restores menstrual function.

Mild hirsutism may accompany ovulatory dysfunction caused by hyperprolactinemia. Whether excess androgen is stimulated by a direct prolactin effect on adrenal cortex synthesis of dehydroepiandrosterone (DHEA) and its sulfate (DHEAS) or is primarily related to the chronic anovulation of these patients (and hence ovarian androgen secretion) is not settled. Another possibility is hyperinsulinemia. Women with elevated prolactin levels have been reported to have an association with hyperinsulinemia because of an increase in peripheral insulin resistance.<sup>107,108,109,110,111,112,113,114</sup> This association is independent of obesity; however, there is considerable variation and the mechanism is uncertain. We recommend that in patients with hyperprolactinemia who have a family history of early coronary heart disease or who have an abnormal lipid profile, consideration should be given to the evaluation and management of hyperinsulinemia as described in [Chapter 11](#).

In the pathophysiology of male hypogonadism, hyperprolactinemia is much less common, and the incidence of actual galactorrhea quite rare. Hyperprolactinemia in men usually presents with decreased libido and potency.

If galactorrhea has been present for 6 months to 1 year, or hyperprolactinemia is noted in the process of working up menstrual disturbances, infertility, or hirsutism, the probability of a pituitary tumor must be recognized. The evaluation and management of hyperprolactinemia are presented in detail in [Chapter 10](#).

Galactorrhea as an isolated symptom of hypothalamic dysfunction existing in an otherwise healthy woman does not require treatment. Periodic prolactin levels, if within normal range, confirm the stability of the underlying process. However, some patients find the presence or amount of galactorrhea sexually, cosmetically, and emotionally burdensome. Treatment with combined oral contraceptives, androgens, danazol, and progestins has met minimal success. Dopamine agonist treatment, as described in [Chapter 10](#), therefore, is the therapy of choice. Even with normal prolactin concentrations and normal imaging, treatment with a dopamine agonist can eliminate galactorrhea.

# THE MANAGEMENT OF MASTALGIA

---

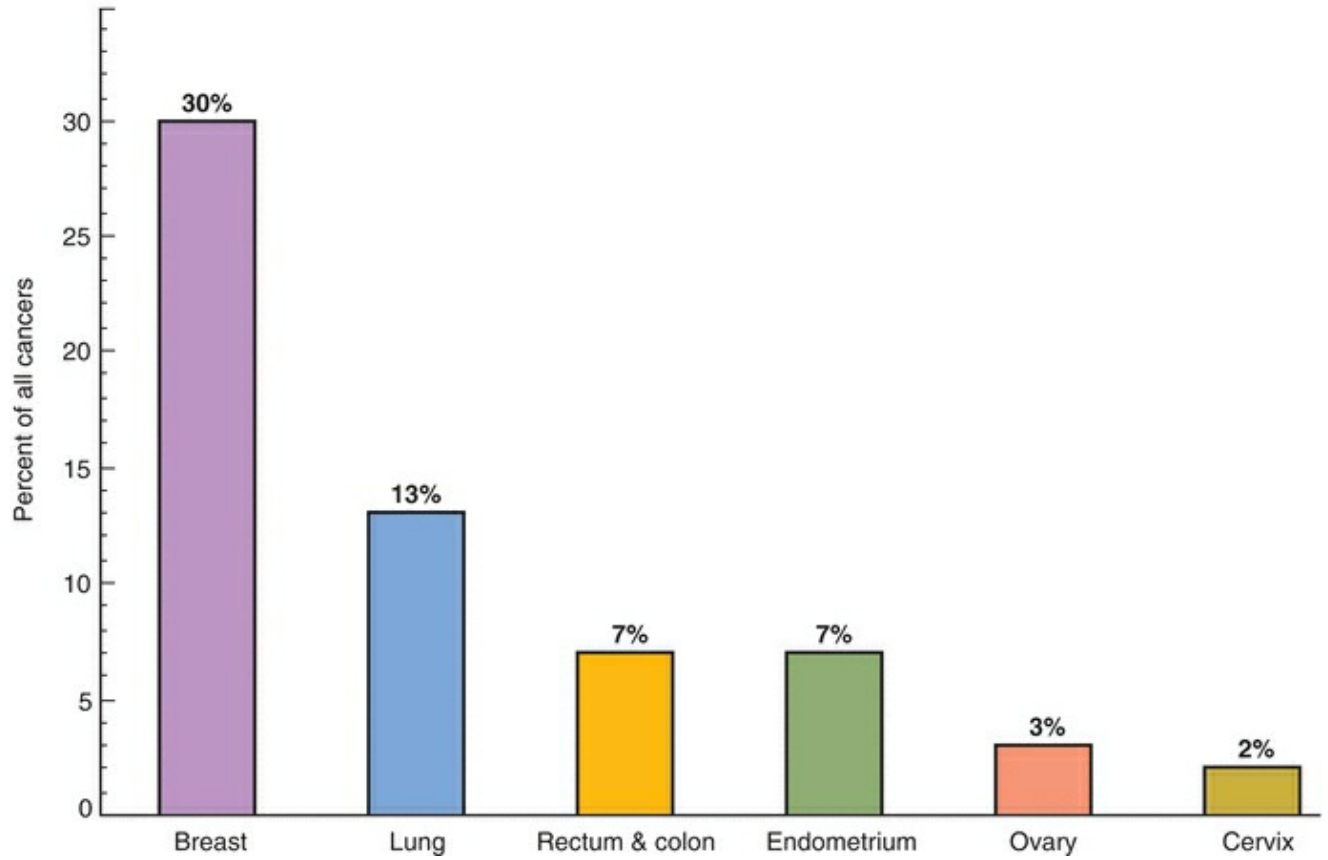
The cyclic premenstrual occurrence of breast discomfort is a common problem and is occasionally associated with dysplastic, benign histologic changes in the breast. Neither a specific etiology (although the response is probably secondary to the hormonal stimulation of the luteal phase) nor an adverse consequence (such as an increased risk of breast cancer) has been established.<sup>115</sup> Approximately 70% of women report premenstrual breast discomfort in surveys, and interference with activities is recorded in 10–30%.<sup>115</sup>

Medical treatment of mastalgia has historically included a bewildering array of options. Several are of questionable value. Diuretics have little impact, and thyroid hormone treatment is indicated only when hypothyroidism is documented. Steroid hormone treatment has been tried in many combinations, mostly unsupported by controlled studies. An old favorite, with many years of clinical experience testifying to its effectiveness, is testosterone. One must be careful, however, to avoid virilizing doses. In recent years, these methods have been supplanted by several new approaches.

Danazol in a dose of 100–200 mg/day is effective in relieving discomfort as well as decreasing nodularity of the breast.<sup>116,117</sup> A daily dose is recommended for a period of 6 months. This treatment may achieve long-term resolution of histologic changes in addition to the clinical improvement. Doses below 400 mg daily do not assure inhibition of ovulation, and a method of effective contraception is necessary because of possible teratogenic effects of the drug. Significant improvement has been noted with vitamin E, 600 units/day of the synthetic tocopherol acetate. No side effects have been noted, and the mechanism of action is unknown.<sup>118</sup> Bromocriptine (2.5 mg/day, which can be administered vaginally if side effects are a problem) and antiestrogens such as tamoxifen (10 or 20 mg daily) are also effective for treating mammary discomfort and benign disease.<sup>117,119,120</sup> In a comparison study, tamoxifen was more effective than danazol.<sup>117</sup>

Clinical observations suggested that abstinence from methylxanthines leads to resolution of symptoms. Methylxanthines (caffeine, theophylline, and theobromine) are present in coffee, tea, chocolate, and cola drinks. In controlled studies, however, a significant placebo response rate (30–40%) has been observed. Careful assessments of this relationship in controlled studies failed to demonstrate a link between methylxanthine use and mastalgia, mammographic changes, or atypia (pre-malignant tissue changes).<sup>121,122</sup> In addition, studies have consistently failed to detect a convincing link between methylxanthine-containing beverages and the risk of breast cancer<sup>123,124,125,126,127</sup> (**Figure 16.6**).

### Cancer Site Incidence in US Women<sup>128</sup>



**FIGURE 16.6**

# CANCER OF THE BREAST

---



## Scope of the Problem

Currently, female American newborns have a lifetime probability of developing breast cancer of 12.4%, about one in eight, double the risk in 1940.<sup>128,129</sup> There are about 252,000 new cases of invasive breast cancer and 63,000 new cases of in situ breast cancer per year in the United States. Between 2002 and 2003, there was a 7% decrease in the incidence of invasive breast cancer, and since 2004, breast cancer incidence has stabilized.<sup>128</sup> This decrease and stabilization are believed to reflect a reduction in the use of postmenopausal hormone therapy following the publicized results of the Women's Health Initiative in 2002 (Chapter 17), as well as an increase in the utilization of mammography in the 1990s. About 97% of all breast cancers in the United States occur in women over age 40; 77% of all cases occur over age 50.<sup>128</sup>

Mortality rates remained disappointingly constant until a decline began in the 1990s. The 5-year survival rate for localized breast cancer (about 61% of breast cancers) has risen from 72% in the 1940s to 99%.<sup>128</sup> This is attributed to better therapy and earlier diagnosis because of the greater utilization of screening mammography. With regional spread, the 5-year survival rate for breast cancer is 85%; with distant metastases, the rate is 27%. The breast is the leading site of cancer in US women and is the second highest cause of cancer death in US women (behind lung cancer)<sup>130</sup> (Table 16.2, Figures 16.7 and 16.8).

### **TABLE 16.2 The Chances of Developing Breast Cancer in the United States According to Age<sup>128</sup>**

---

Birth to age 39 1 in 228

---

Age 40–59 1 in 24

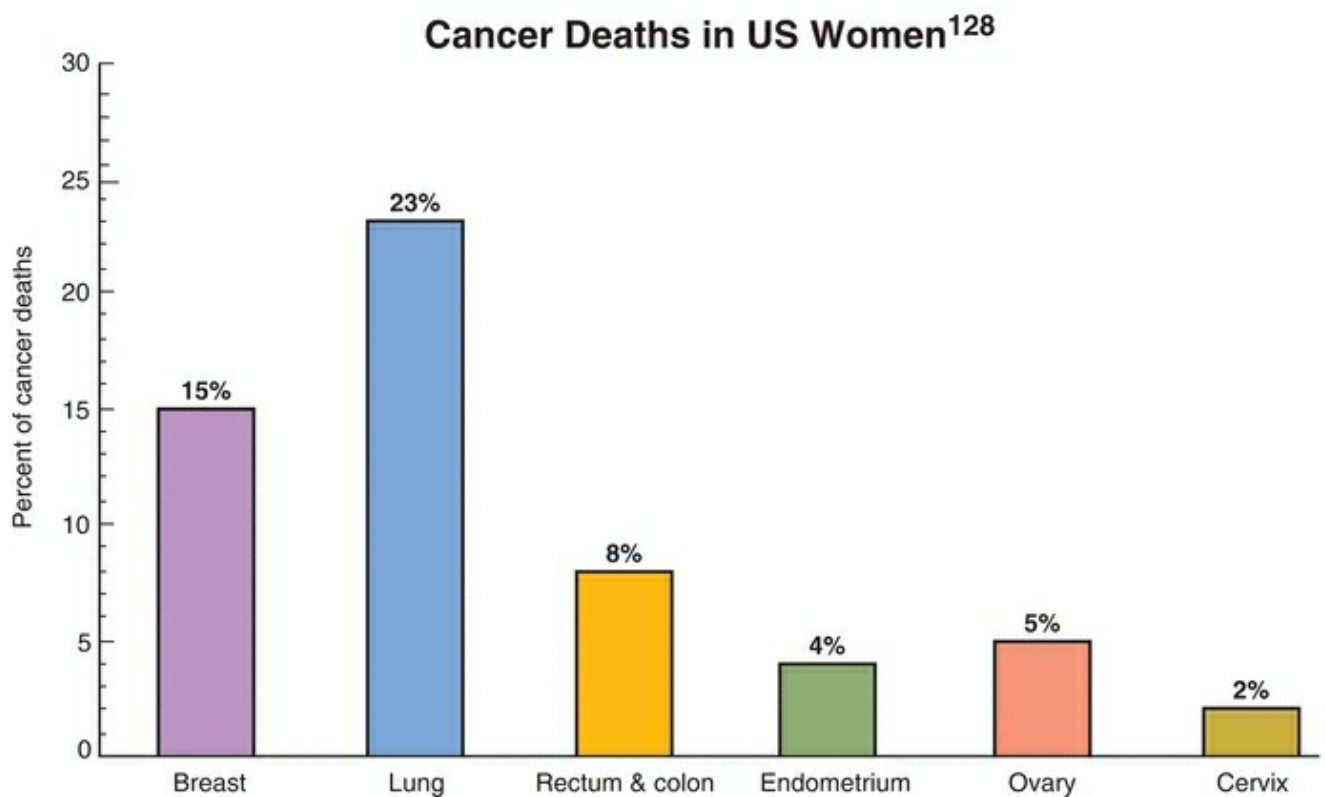
---

Age 60–79 1 in 14

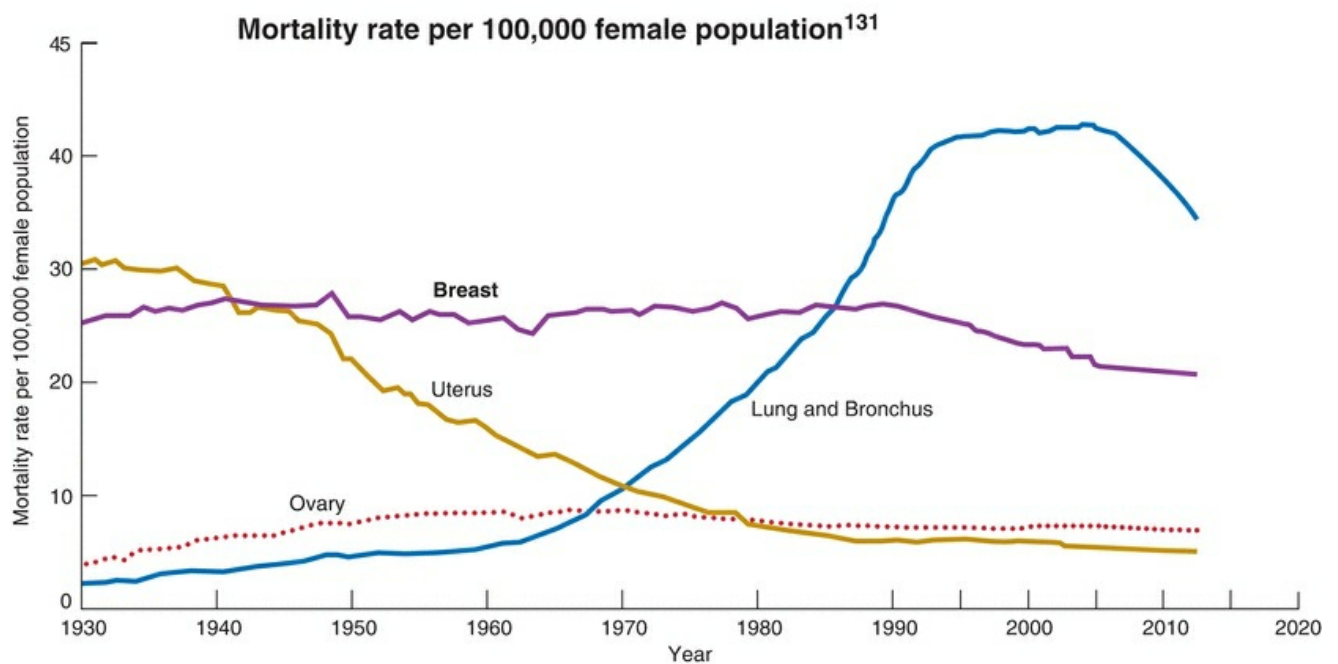
---

Birth to death 1 in 8

---



**FIGURE 16.7**



**FIGURE 16.8**

Over the years, breast cancer continued to have a deadly impact despite advances in surgical and diagnostic techniques. Classically, the single most useful prognostic information in women with operable breast cancer has been the histologic status of the axillary lymph nodes.<sup>131,132</sup> The survival rate is higher with axillary lymph nodes negative for disease compared with positive nodes. Because of this recognition of the importance of the axillary nodes, the traditional surgical approach to breast cancer was based on the concept that breast cancer is a disease of stepwise progression. **There is an important change in concept. Breast cancer is now viewed as a systemic disease, with spread to local and distant sites at the same time. Breast cancer is best viewed as occultly metastatic at the time of presentation.** Therefore, dissemination of tumor cells has occurred by the time of surgery in many patients with invasive lesions and even in some patients with noninvasive tumors.

Because we have been dealing with a disease that has already reached the point of dissemination in many patients, we must move the diagnosis forward several years in order to have an impact on breast cancer mortality. Earlier diagnosis requires that we should be aware of what it is that makes a high-risk patient. **However, keep in mind that the great majority of women (85%) who develop breast cancer do not have an identifiable risk factor other than age, and therefore, every woman must be considered at risk.**

# Risk Factors

A constellation of factors influences the risk for breast cancer. These include reproductive experience, ovarian activity, benign breast disease, familial tendency, genetic differences, dietary considerations, and specific endocrine factors. Clinicians can calculate the risk for an individual patient at the National Cancer Institute Internet site: <http://www.cancer.gov/bcrisktool/> (Table 16.3).

## TABLE 16.3 Risk Factors for Breast Cancer<sup>130</sup>

Relative risk >4.0

Over age 65

Inherited mutations

Two or more first-degree relatives with early disease

Postmenopausal breasts that are at least 75% dense on mammography

---

Relative risk 2.1–4.0

One first-degree relative with breast cancer

Atypical hyperplasia on breast biopsy

High-dose radiation to the chest

High postmenopausal bone density

---

Relative risk 1.1–2.0

First full-term pregnancy after age 30

Menarche before age 12

Menopause after age 55

Nulliparity

Never breastfed

Postmenopausal obesity

Previous cancer of the endometrium, ovary, or colon

Alcohol consumption, 2–5 drinks daily

---

# Reproductive Experience

The risk of breast cancer increases with the increase in age at which a woman bears her first full-term child. A woman pregnant before the age of 18 has about one-third the risk of one who first delivers after the age of 35. To be protective, pregnancy must occur before the age of 30. Age at first birth and multiparity in women who experience their first birth before age 25 reduce the risk of breast cancer that is positive for estrogen and progesterone receptors.<sup>131,132</sup> Women over the age of 30 years at the time of their first birth have a greater risk than women who never become pregnant.<sup>133</sup> There is reason to believe that the age at the time of birth of the last child is the most important influence (an increasing risk with increasing age).<sup>134</sup> There is, however, a significant protective effect with increasing parity, present even when adjusted for age at first birth and other risk factors.<sup>135,136</sup> Delayed childbearing and fewer children in modern times are believed to have contributed significantly to the increased incidence of breast cancer observed in the 1990s.

Although pregnancy at an early age produces an overall lifetime reduction in risk, there is evidence that the first few years after delivery are associated with a transient increase in risk.<sup>137</sup> This increase probably reflects accelerated growth of an already present malignancy by the hormones of pregnancy. A very large case-control study concluded that pregnancy transiently increases the risk (perhaps for up to 3 years) after a woman's first childbirth, and this is followed by a lifetime reduction in risk.<sup>138</sup> And some have found that a concurrent or recent pregnancy (3–4 years previously) adversely affects survival (even after adjustment for size of tumor and number of nodes).<sup>139,140</sup> It is argued that breast cells that have already begun malignant transformation are adversely affected by the hormones of pregnancy, while normal stem cells become more differentiated and resistant, reducing the number of stem cells capable of malignant change. The number of breast stem cells available for this beneficial response diminishes with age and succeeding pregnancies.<sup>141</sup> Although it is likely that this effect is mediated by estrogen and progesterone, experimental evidence indicates the presence of LH receptors in breast tissue, and it is possible that human chorionic gonadotropin (hCG) contributes to the protective differentiation of breast cells.<sup>142,143,144</sup> Another possibility is an antiproliferative action of alpha-fetoprotein, a peptide that is secreted in the fetal liver and stimulated by the hormones of pregnancy.<sup>145,146</sup>

Initially, conflicting results were reported in over 20 studies examining the risk of breast cancer associated with the number of abortions (both spontaneous and induced abortions) experienced by individual patients.<sup>147,148</sup> Concern for an adverse effect was based on the theoretical suggestion that a full-term pregnancy protects against breast cancer by invoking complete differentiation of breast cells, but abortion increases the

risk by allowing breast cell proliferation in the first trimester of pregnancy, but not allowing the full differentiation that occurs in later pregnancy. In these studies, there was a major problem of recall bias; women who develop breast cancer are more likely to truthfully reveal their history of induced abortion than healthy women. In studies that avoided recall bias (e.g., by deriving data from national registries instead of personal interviews), the risk of breast cancer was identical in women with and without induced abortions.<sup>148,149</sup> More careful case-control studies failed to link a risk of breast cancer with either induced or spontaneous abortions.<sup>150,151</sup> Similarly, newer prospective cohort studies, including the Nurses' Health Study, also reported no association between the incidence of breast cancer and induced or spontaneous abortions.<sup>152,153,154</sup>

The fact that pregnancy early in life is associated with a reduction in the risk of breast cancer implies that etiologic factors are operating during that period of life. The protection afforded only by the first pregnancy suggests that the first full-term pregnancy has a trigger effect that either produces a permanent change in the factors responsible for breast cancer or changes the breast tissue and makes it less susceptible to malignant transformation. There is evidence for a lasting impact of a first pregnancy on a woman's hormonal milieu. A small but significant elevation of estriol, a decrease in DHEA and DHEAS, and lower prolactin levels all persist for many years after delivery.<sup>155,156</sup> These changes take on significance when viewed in terms of the endocrine factors considered below.

Lactation may offer a weak to moderate protective effect (20% reduction) on the risk of breast cancer, both estrogen receptor–positive and estrogen receptor–negative tumors.<sup>132,133,157,158,159,160,161,162,163,164,165</sup> The same beneficial effect has been reported in BRCA mutation carriers in one study, but not in another.<sup>166,167</sup> The Nurses' Health Study could not detect a protective effect of lactation, and a Norwegian prospective study, including a high percentage of women with long durations of breastfeeding, found no benefit on either premenopausal or postmenopausal breast cancer incidence.<sup>168,169</sup> The impact of lactation, if significant, must be small. However, an analysis of the worldwide available data concluded that breastfeeding would reduce the risk of breast cancer by 4.3% per year of breastfeeding and potentially could reduce the cumulative incidence by age 70 by more than 50%.<sup>170</sup> A meta-analysis indicated that breastfeeding reduced the risk of breast cancer by about 10–20%, and the impact was limited to premenopausal women.<sup>171</sup> There is a unique and helpful study of the Chinese Tanka, who are boat people living on the coast of Southern China.<sup>172</sup> The women of the Chinese Tanka wear clothing with an opening only on the right side, and they breastfeed only with the right breast. All breast cancers were in postmenopausal women, and the cancers were equally distributed between the two sides, suggesting a protective effect only for premenopausal breast cancer.

In both cohort and case-control studies, there is good evidence that cosmetic breast augmentation does not increase the risk of breast cancer.<sup>173,174</sup> Specifically, studies have failed to indicate an increased risk of breast cancer in women who have had cosmetic breast implants.<sup>175,176,177,178,179</sup>



# Ovarian Activity

Women who have a premenopausal oophorectomy have a lower risk of breast cancer, and the lowered risk is greater the younger a woman is when ovariectomized. There is a 70% risk reduction in women who have oophorectomy before age 35. There is a small decrease in risk with late menarche and a moderate increase in risk with late natural menopause, indicating that ovarian activity plays a continuing role throughout reproductive life.<sup>180</sup>

Observational studies indicated that anovulatory and infertile women (exposed to less progesterone) have a small increased risk of breast cancer later in life.<sup>181,182,183,184</sup> However, the statistical power of these observational studies was limited by small numbers (all fewer than 15 cases). Larger numbers are available in the Nurses' Health Study, where the opposite result was apparent: a reduction in the incidence of breast cancer in women with infertility attributed to ovulatory disorders.<sup>185</sup>

# Benign Breast Disease

Benign breast lesions are present in over 70% of women undergoing breast biopsy and are stratified into nonproliferative lesions, proliferative without atypia, atypical hyperplasia, and lobular carcinoma in situ.<sup>186</sup> Women with prior benign breast disease form only a small proportion of breast cancer patients, approximately 5%. The risk of developing future breast cancer depends on the severity of the lesion. Nonproliferative lesions such as simple cysts portend a 1.17 relative risk of future breast cancer. Fibrocystic change, a proliferative lesion without atypia, is characterized by dilation of terminal ducts (ductal ectasia) and alveoli, a process caused by obstruction of ducts (probably by stromal fibrosis), persistent secretion, and retention of the secretory material. Fibroadenomas are the most common cause of breast masses in premenopausal women and account for 12% of breast masses in menopausal women.<sup>187</sup> Other examples of proliferative lesions without atypia are intraductal papillomas and moderate hyperplasia of the usual type. In the Nurses' Health Study, biopsies with proliferative disease had a relative risk of breast cancer of 1.6.<sup>188</sup> Women with atypical hyperplasia had a relative risk of 5.3, while women with atypia and a family history of breast cancer had a relative risk of 11. Only 4–10% of benign biopsies have atypical hyperplasia. For most women, benign breast lesions are not a disease but a physiologic change brought about by cyclic hormonal activity<sup>189</sup> (Table 16.4).

## TABLE 16.4 Classification of Breast Biopsy Tissue According to Risk for Breast Cancer



No increased risk

---

Adenosis

Duct ectasia

Fibrosis

Mild hyperplasia (3–4 cells deep)

Mastitis

Periductal mastitis

Squamous metaplasia

Ordinary cysts (fibrocystic disease)

---

Slightly increased risk (1.5–2 times)

---

Fibroadenoma with complex features

Moderate or florid hyperplasia

Several papillomas

Sclerosing adenosis

---

Moderately increased (4–5 times)

---

Atypical ductal hyperplasia

Atypical lobular hyperplasia

---

Markedly increased (8–10 times)

---

Ductal carcinoma in situ

Lobular carcinoma in situ

---

## Familial Tendency

Most breast cancers are sporadic, that is, they arise in individuals without a family history of breast cancer. However, female relatives of women with breast cancer have about twice the rate of the general population. There is an excess of bilateral disease among patients with a family history of breast cancer. Relatives of women with bilateral disease have about a 45% lifetime chance of developing breast cancer. The relative risks associated with first-degree relatives are presented in [Table 16.5](#).

**TABLE 16.5 Relative Risk with Affected First-Degree Relatives**<sup>190</sup>

One relative	1.80
Two relatives	2.93
Three relatives	3.90

It is worth emphasizing that only one of nine women who develop breast cancer has an affected first-degree relative, and most women with an affected relative will never have breast cancer.<sup>190</sup>

The breast and ovarian tumor suppressor gene (BRCA1) associated with familial cancer is on the long arm of chromosome 17, localized to 17q12–q21.<sup>191</sup> Although other genetic alterations have been observed in breast tumors, multiple, different mutations in BRCA1 are believed to be responsible for approximately 20% of familial breast cancer and 80% of families with both early-onset breast and ovarian cancer. **Overall, no more than 5–10% of breast cancers in the general population can be attributed to inherited mutations.**<sup>128,190</sup> Autosomal dominant inheritance of mutations in this gene can be either maternal or paternal; male carriers are at increased risk for colon and prostate cancers.<sup>192,193</sup> A second autosomal dominant locus of multiple mutations, BRCA2, on chromosome 13q12–q13 accounts for up to 35% of families with early-onset breast cancer (but a lower rate of ovarian cancer) and, in males, for prostate cancer, pancreatic cancer, and male breast cancer.<sup>193,194</sup> Together, BRCA1 and BRCA2


account for 80% of families with multiple cases of early-onset breast cancer.<sup>195</sup> **About 5–10% of women who develop ovarian cancer have mutations in BRCA1.**<sup>196,197,198</sup>

BRCA1 encodes a 1,863-amino acid protein with a zinc finger domain that is a tumor suppressor important in DNA repair. Mutations in many different regions of the BRCA1 gene cause a loss or reduction in its function.<sup>199,200</sup> Because not every individual with a mutation in this gene develops cancer, other factors are involved, making the accuracy of prediction more difficult and arguing against widespread screening for mutations of this gene. Providing accurate numbers is a difficult task, because breast cancer has a multifactorial etiology with both genetic and environmental factors. The BRCA1 gene could play a role in sporadic breast and ovarian cancer, but analysis of tumors has failed to find mutations in sporadic cancers that occur later in life.<sup>201</sup>

High-risk families have a high probability of harboring a mutation in a dominant breast cancer susceptibility gene. It is estimated that approximately 0.04–0.2% of women in the United States carry the BRCA1 susceptibility (and BRCA2 is less common).<sup>202</sup> Among women of Ashkenazi Jewish descent, the prevalence of BRCA1 and BRCA2 mutations is about 2%.<sup>203</sup> The percentage of breast cancer cases in the general population associated with a family history accounts for only a minor part of the overall prevalence, as low as 3%.<sup>204,205</sup> In addition, there appears to be great variability in different parts of the world, and the prevalence in minority populations has not been adequately measured.

The presence of ovarian cancer or breast cancer within a family should prompt genetic counseling and possibly genetic screening for hereditary breast and ovarian cancer syndromes.<sup>206</sup> High-risk families have the presence of multiple cases of breast cancer in close relatives (usually at least three cases) that follows an autosomal dominant pattern of inheritance; breast cancer is usually diagnosed before age 45; there may be cases of ovarian cancer in the family as well. Many of the cases, but not all, can be attributed to the susceptibility genes BRCA1 and BRCA2. High-risk families have the following cumulative breast cancer risk by the age of 80 as determined by the analysis of family histories<sup>202</sup> (Tables 16.6 and 16.7).

## **TABLE 16.6 Family History Characteristics Associated with the Presence of BRCA Mutations**



---

Early age of onset of breast cancer within a family

---

Relatives with ovarian, primary peritoneal, or fallopian tube cancer

---

Male relatives with breast cancer

---

Three or more close relatives with breast cancer

---

Close relatives with bilateral breast cancer

---

Ashkenazi (Eastern European Jewish), French Canadian, or Icelandic ancestry

---

**TABLE 16.7 Risk of Breast Cancer Based on Family History**

<b>Affected Relative</b>	<b>Age of Affected Relative</b>	<b>Cumulative Breast Cancer Risk by Age 80</b>
One first-degree relative	<50 years old	13–21%
	50 or more years old	9–11%
One second-degree relative	<50 years old	10–14%
	50 or more years old	8–9%
Two first-degree relatives	Both <50 years old	35–48%
	Both 50 years or older	11–24%
Two second-degree relatives but both paternal or maternal	Both <50 years old	21–26%
	Both 50 years or older	9–16%

Each child of a BRCA mutation carrier has a 50% chance of inheriting the mutation. In the United States, women who are carrying the BRCA1 mutation have a 46% cumulative risk of developing breast cancer by age 70, 57% risk overall, and a 39% risk for ovarian cancer.<sup>207,208</sup> There is also a small increase in the risk for other cancers, specifically of the pancreas, colon, uterus, and cervix.<sup>209</sup> The male relatives who are carrying this mutation have an increased risk of prostate cancer and colon cancer in addition to a cumulative risk of breast cancer of 1.2%.<sup>210</sup> The cancer risk for women with BRCA2 mutations is 43% for breast cancer and 22% for ovarian cancer by age 70 and a 49% risk of breast cancer overall.<sup>207,208</sup> Male BRCA2 mutation carriers have a higher cumulative risk of breast cancer, 6.8%, compared with male BRCA1 carriers.<sup>210</sup> In addition, BRCA2 mutation carriers have increased risks of cancers originating in the pancreas, prostate, gallbladder and bile duct, stomach, and skin.<sup>211</sup> Breast cancer associated with BRCA1 mutations is histologically different (more often aneuploid and

receptor-negative) compared to BRCA2 mutations and sporadic cancers and appears to grow faster but, paradoxically, has a better survival in response to treatment.<sup>212</sup> Outcome results, however, have not been consistent. A well-done Dutch study could not detect a difference in disease-free and overall survival comparing breast cancer cases from families with proven BRCA1 mutations to patients with sporadic breast cancer<sup>213</sup> (Table 16.8).

**TABLE 16.8 Summary of Breast and Ovarian Cancer Risk in BRCA Carriers<sup>207</sup>**

	Breast Cancer Risk by Age 70 (%)	Ovarian Cancer Risk by Age 70 (%)
<i>BRCA1</i>	46	39
<i>BRCA2</i>	43	22

Because not all families with breast cancer carry mutations of BRCA1 or BRCA2, these families probably have other less common breast cancer susceptibility genes, some of which remain to be identified. In addition, the current screening methods do not detect all BRCA mutations. For example, a mutation in a gene involved in the recognition and repair of damaged DNA, CHEK2, is prevalent in families with hereditary breast and colorectal cancer.<sup>214</sup> Other genes that infrequently cause inherited breast cancer include the ATM gene, the p53 tumor suppressor gene, and the PTEN gene.<sup>129</sup> **When three or more closely related individuals within a family have been diagnosed with breast cancer, the likelihood that an inherited dominant genetic mutation is present is very high.** The affected women need not be first-degree relatives, but they must be related either all on the mother’s side or the father’s side. Identifying the families that carry the BRCA2 gene uses the same historical criteria as that for the BRCA1 gene. **The family presence of just one case of ovarian cancer further increases the likelihood of the BRCA1 mutation.** In contrast to BRCA1 families, BRCA2 families have only a moderately increased incidence of ovarian cancer.

Once it has been determined that a family is at high risk for a breast cancer gene



mutation, it is recommended that this family be referred to an appropriate laboratory and service that can be identified through the medical genetics department at a regional referral institution. Although blood samples can be mailed by overnight mail, involvement with an appropriate center is highly urged because of the importance of accurate informed consent, counseling, and follow-up care. The way in which information is communicated to patients has a profound impact on decision-making and compliance with surveillance.

If a patient tests positive for a genetically inherited predisposition to breast cancer, or if a patient has two or more first-degree relatives in which breast cancer was diagnosed before age 50, or if a patient has three or more first-degree relatives with breast cancer at any age, we recommend following at-risk screening guidelines for early detection of breast cancer.<sup>215</sup> For patients aged 25–29, this means an annual breast MRI with contrast and breast exams every 6–12 months.<sup>216,217</sup> For women over age 30, alternating annual breast MRI with contrast and annual mammogram every 6 months, as well as breast exams every 6–12 months, are appropriate.<sup>216,218</sup> Prophylactic mastectomy should also be discussed with these patients. High-risk women who have undergone prophylactic mastectomy experience a major reduction (more than 90%) in the number of breast cancers, although total prevention is not achieved.<sup>219,220,221</sup> Because the mutation is present in every cell, and prophylactic mastectomy does not remove all tissue, there is no guarantee that breast cancer will be totally prevented. Any discussion of mastectomy should include psychosocial considerations and side effects of surgery, which can include decreased sexual satisfaction; negative body image; decreased anxiety about the development of breast cancer; pain, tingling, or numbness at the surgical site; and a routine discussion of typical surgical complications such as infection or bleeding issues.<sup>222,223,224,225</sup> The same situation applies with prophylactic oophorectomy in that a carcinoma can arise from peritoneal cells. However, prophylactic salpingo-oophorectomy reduces the risk of ovarian cancer by about 90% and the risk of breast cancer by about 50%.<sup>225,226</sup> Risk-reducing salpingo-oophorectomy is recommended at age 35 or when childbearing is complete for patients carrying BRCA1 mutations, and by age 40 in BRCA2 carriers. In patients with a PTEN mutation, annual endometrial biopsy starting at age 30 and hysterectomy when childbearing is complete are also recommended as these patients are at risk of uterine cancer in addition to breast cancer.<sup>216</sup>

In contrast to being associated with a lower ovarian cancer risk, the impact of oral contraceptives on the risk of breast cancer in patients carrying a BRCA1 or BRCA2 mutation is not clear. A case-control study concluded that BRCA1 (but not BRCA2) mutation carriers had small increases in the risk of breast cancer in users for at least 5 years (OR = 1.33, CI = 1.11–1.60), in users before age 30 (OR = 1.29, CI = 1.09–1.52),

and in those who developed breast cancer before age 40 (OR = 1.38, CI = 1.11–1.72).<sup>227</sup> In contrast, another case-control study concluded that oral contraceptive use for at least 5 years doubled the risk of breast cancer before age 50 in BRCA2 carriers, but not in BRCA1 carriers.<sup>228</sup> A retrospective analysis of an international cohort of BRCA carriers indicated that an increased risk of breast cancer with both BRCA1 and BRCA2 carriers was present only with 4 or more years of use before a first full-term pregnancy.<sup>229</sup> A study that focused on low-dose oral contraceptives could detect no association with breast cancer risk in BRCA mutation carriers.<sup>167</sup> Another case-control study found no increase in the risk of breast cancer diagnosed before age 40 in either BRCA1 or BRCA2 carriers.<sup>230</sup> And finally, a case-control study could detect no significant increase in the risk of contralateral breast cancer among BRCA1 and BRCA2 carriers or in noncarriers with the use of oral contraceptives or postmenopausal hormones.<sup>231</sup>

**The data with oral contraceptives in BRCA mutation carriers are all observational and not robust. Until better information is forthcoming, it seems reasonable to inform carriers of BRCA mutations that the use of oral contraceptives is likely to reduce the risk of ovarian cancer, but the effect on breast cancer risk is uncertain.**

The effect of chemoprevention by tamoxifen and raloxifene has not been tested in BRCA mutation carriers by randomized trials. However, in subgroup analyses of the American trial assessing the effect of tamoxifen for prevention, tamoxifen reduced the risk of breast cancer by 62% in BRCA2 carriers but had no impact in BRCA1 carriers.<sup>232,233</sup> This is consistent with the fact that women with BRCA2 mutations have predominately estrogen receptor–positive tumors and women with BRCA1 mutations have mostly estrogen receptor–negative tumors. Raloxifene has been shown to decrease primary breast cancer by 7 cases per 1,000 women when compared to placebo.<sup>234</sup> When compared with raloxifene, tamoxifen prevented 5 more cases of primary breast cancer per 1,000 women.<sup>234</sup> In a randomized controlled trial of postmenopausal women at high risk of breast cancer, the aromatase inhibitor anastrozole was shown to decrease risk of primary breast cancer by about 50% over placebo.<sup>235</sup> Given the side effects associated with these drugs, the decision to use one of these agents for chemoprevention is a difficult one for both clinician and patient. Prophylactic bilateral salpingo-oophorectomy remains as the superior choice for risk protection, a procedure that can in most cases be easily performed by laparoscopy. Serial sectioning of the ovaries and tubes is mandatory to detect microscopic cancers.

In a cohort of women with BRCA1/2 who had oophorectomy, hormone therapy of any type did not alter the reduction in breast cancer.<sup>236</sup> The average length of follow-up

was 3.6 years. A case-control study of 472 postmenopausal women with a BRCA1 mutation found that women who used hormone therapy after prophylactic oophorectomy, either estrogen only or combined estrogen-progestin, not only did not have an increased risk of breast cancer, but hormone use was actually associated with a decreased risk.<sup>237</sup> The findings were the same regardless of duration of use or current or past use. The conclusion is encouraging but limited by the fact that 68% of the tumors in the study were estrogen receptor– negative, making the estrogen receptor–positive tumors (that are more likely to be influenced by hormone use) relatively small in number.

Women who are BRCA carriers face difficult decisions regarding hormonal treatment for menopausal symptoms. The experience thus far indicates that hormone therapy can be used safely for several years. Continuing follow-up of these patients may extend this period of safety even longer.

# Dietary Factors

The geographic variation in incidence rates of breast cancer is considerable (the United States has the highest rates and Japan the lowest), and it has been correlated with the amount of animal fat in the diet.<sup>236</sup> Lean women, however, have an increased incidence of breast cancer, although this increase is limited to small, localized, and well-differentiated tumors.<sup>237</sup> Furthermore, studies have failed to find evidence for a positive relationship between breast cancer and dietary total or saturated fat or cholesterol intake.<sup>238,239,240,241</sup> One study found that dietary fat is a stronger risk factor for postmenopausal breast cancer than for premenopausal breast cancer, but another study had the opposite conclusion.<sup>242,243</sup> Although a cohort study concluded that dietary fat is a determinant of postmenopausal breast cancer, the association did not achieve statistical significance.<sup>244</sup> And another very large cohort study in Europe demonstrated only a very weak link between saturated fat intake and the risk of breast cancer, only in nonusers of hormone therapy.<sup>245</sup> Thus, the epidemiologic literature provides little support for a major contribution of dietary fat to the risk of breast cancer. Nevertheless, there is a correlation between intra-abdominal fat (android obesity) and the risk of breast cancer, a consequence of excessive caloric consumption, however, not a specific dietary component.<sup>246</sup> Presumably, the connection between android obesity and breast cancer is through the metabolic perturbations, especially hyperinsulinemia, associated with excessive body weight.

The incidence of breast cancer is increased in countries associated with affluent, unfavorable diets (high fat content) and a lack of physical exercise. Indeed, increased physical activity in postmenopausal women reduces the risk of breast cancer.<sup>247</sup> The common denominator may be the peripheral insulin resistance and hyperinsulinemia that become prevalent with aging and weight gain in affluent, modern societies. This specific metabolic change is becoming a common theme in various clinical conditions, particularly noninsulin-dependent diabetes mellitus, anovulation and polycystic ovaries, hypertension, and dyslipidemia. Hyperinsulinemia is found more often in women with breast cancer.<sup>248</sup> There are, indeed, many reasons to avoid excess body weight. The risk of breast cancer is reduced in women who exercise regularly.<sup>249</sup>

The increased circulating levels of insulin that are a consequence of obesity-induced insulin resistance can directly stimulate breast tissue growth and can also increase levels of biologically active estradiol by lowering sex hormone-binding globulin (SHBG) synthesis in the liver. In a cohort of women enrolled in the Women's Health Initiative, an increase in the risk of breast cancer in obese women who were not using hormone therapy correlated with hyperinsulinemia and elevated estradiol levels, but not with IGF-1 levels.<sup>250</sup> An adjustment for estrogen levels indicated that the

hyperinsulinemia acted independently and was the more robust factor. The inability to demonstrate this association with hyperinsulinemia in hormone users may be a consequence of the lower insulin levels caused by estrogen treatment.

In the parts of the world where soy intake is high, there is a lower incidence of breast, endometrial, and prostate cancers. For example, a case-control study concluded that there was a 54% reduced risk of endometrial cancer, and other case-control studies found a reduction in the risk of breast cancer, in women with a high consumption of soy and other legumes.<sup>251,252,253</sup> It is by no means certain, however, that there is a direct effect of soy intake.<sup>254</sup> Soy intake may be a marker for other factors in lifestyle or diet that are protective. Short-term studies on breast secretions have actually indicated that soy intake produces an estrogenic response.<sup>255,256,257</sup> The effect of soy intake on the risk of breast cancer is discussed in greater detail in [Chapter 17](#).

After migration to the United States, Asian women gradually increase (sixfold) their risk of breast cancer over several generations, eventually reaching the level of white women.<sup>258</sup> Evidence indicates that this reflects a change in diet and lifestyle, with an increase in risk associated with a gain in height and weight.<sup>259,260</sup> Recent weight gain is especially associated with increased risk. A reduced risk, however, is observed in heavy, younger women.

The effect of body weight on the risk of breast cancer differs in premenopausal and postmenopausal women. In premenopausal women who are overweight, the risk of breast cancer is lower compared with normal-weight individuals, and in postmenopausal women, especially in nonusers of hormone therapy, excess weight is associated with either an unchanged or slightly increased risk.<sup>261,262,263,264</sup> This is attributed to a more marked increase in total and free estrogen levels in overweight postmenopausal women, in contrast to lower levels with increasing weight in premenopausal women. Postmenopausal obese women have later menopause, higher estrone production rates and higher free estradiol levels (because of insulin-induced lower SHBG levels), and a slightly greater risk for breast cancer.<sup>265</sup> A large Swedish case-control study and an American prospective cohort study suggested that the principal factor is weight gain during adulthood and that the impact on breast cancer emerges 10 years after menopause.<sup>264,266</sup> In the Women's Health Initiative, subjects who prospectively reported weight gain in adulthood were more likely to develop breast cancer postmenopausally.<sup>267</sup> As noted, this weight gain may be the important determinant in the increasing risk experienced by migrants from low-risk parts of the world who move to high-risk areas.

Evidence indicates that the intake of vitamins A, C, and E has no effect on the risk of breast cancer.<sup>268</sup>

## Alcohol in the Diet

There is a modest increase in the risk for estrogen receptor–positive breast cancer with the consumption of one or more alcoholic drinks of all forms per day.<sup>269,270</sup> Almost all of many studies conclude that 2 drinks daily increase the risk by about 20%.<sup>271,272</sup> It is speculated that breast cancer and alcohol are linked through estrogen, either a direct or an indirect effect (e.g., on hepatic enzymes) on estrogen metabolism. An effect of alcohol ingestion by premenopausal women was not demonstrated on circulating levels of estrone, estradiol, DHEAS, or SHBG in a cross-sectional study that depended upon a questionnaire to assess alcohol intake.<sup>273</sup> However, when alcohol is administered under experimental conditions, circulating estrogen concentrations are increased.<sup>274,275,276</sup> And in a prospective cohort study of premenopausal women in Italy, higher estradiol levels were correlated with an increased alcohol intake over a 1-year period of time.<sup>277</sup> Similarly, the increased caloric intake associated with alcohol use may also lead to increased adiposity and elevated insulin levels.

# Specific Endocrine Factors

## Adrenal Steroids

Subnormal levels of etiocholanolone (a urinary excretion product of androstenedione) were found from 5 months to 9 years before the diagnosis of breast cancer in women living on the island of Guernsey, off the English Coast.<sup>278</sup> A subnormal excretion of this 17-ketosteroid was also found in sisters of patients with breast cancer. A sixfold increase in the incidence of breast cancer was found between women excreting less than 0.4 mg of etiocholanolone and those excreting over 1 mg/24 hours. After 37 years of follow-up, low levels of androsterone and etiocholanolone were observed to correlate with an increase in breast cancer only in women under age 50; over age 50, the reverse was true.<sup>279</sup> Measurement of these 17-ketosteroids might be a useful screening procedure to detect a high-risk group of patients because approximately 25% of the population excretes less than 1 mg/24 hours, but these early results have never been pursued.

## Endogenous Estrogens and Androgens

Epidemiologic and other information continue to suggest some estrogen-/progesterin-related promoter function. These include the following: (1) the condition is 100 times more common in women than in men; (2) breast cancer invariably occurs after puberty; (3) untreated gonadal dysgenesis and breast cancer are mutually exclusive; (4) a 65% excess rate of breast cancer has been observed among women who have had an endometrial cancer; and (5) breast tumors contain estrogen and progesterone receptors, which are biologically active. Taken together, these data suggest an element of estrogen/progesterin dependence, if not provocation, in many breast cancers.

Estriol generally has failed to produce breast cancer in rodents, and in fact, estriol protects the rat against breast tumors induced by various chemical carcinogens (but so did estradiol).<sup>280</sup> The hypothesis is that a higher estriol level protects against the more potent effects of estrone and estradiol. This might explain the protective effect of early pregnancies. Women having an early pregnancy continue to excrete more estriol than nulliparous women. Premenopausal healthy Asiatic women have a lower breast cancer risk than Caucasians and also have a higher rate of urinary estriol excretion.<sup>281</sup> When Asiatic women migrate to the United States, however, the risk of breast cancer increases, and their urinary excretion of estriol decreases, perhaps a consequence of dietary changes as noted above. A study of Westernized Asian women also documented a reduction in estrogen 2-hydroxy metabolites, with decreasing values linked to increasing breast cancer risk associated with measures of Westernization.<sup>282</sup>

A major factor in the potency differences among the various estrogens (estradiol, estrone, estriol) is the length of time the estrogen receptor complex occupies the nucleus. The higher rate of dissociation with the weak estrogen (estriol) can be compensated for by continuous application to allow prolonged nuclear binding and activity. Estriol has only 20–30% affinity for the estrogen receptor compared to estradiol; therefore, it is rapidly cleared from a cell. But if the effective concentration is kept equivalent to that of estradiol, it can produce a similar biologic response.<sup>283</sup>

In pregnancy, where the concentration of estriol is very great, it can be an important hormone, not just a metabolite. Thus, higher estriol levels are not necessarily protective. Indeed, antagonism of estradiol occurs only within a very narrow range of the ratio of estradiol to estriol, a range rarely encountered either physiologically or pharmacologically.<sup>284</sup> Below this range, estradiol is unimpeded; above this range, estriol itself exerts estrogenic activity. Indeed, no inhibition of mammary tissue proliferation markers could be detected in women administered with estriol in the presence of an estrogen-progestin oral contraceptive.<sup>285</sup> There have been no epidemiologic studies of breast cancer risk in women treated with estriol, and therefore, the contention that estriol protects against breast cancer remains speculative.

There have been many studies assessing the relationship between endogenous hormone levels and the risk of breast cancer. A pooled analysis of nine prospective studies concluded that the risk of breast cancer, especially estrogen receptor–positive tumors, increases with increasing concentrations of all endogenous estrogens and androgens, including estradiol, estrone, estrone sulfate, androstenedione, DHEA, DHEAS, and testosterone.<sup>286</sup> A prospective study in Sweden found that current use of any estrogen-containing product was associated with a slightly higher risk of breast cancer, but use of estriol specifically was associated with a lower risk of breast cancer, when compared to women who had never used exogenous hormones.<sup>287</sup> The overall increase in breast cancer risk was about twofold comparing the lowest endogenous levels in postmenopausal women with the highest levels. This relationship is seen with both estrogens and androgens.<sup>288,289</sup> Postmenopausal women who are overweight have an increased risk of breast cancer, and analyses that adjusted for the increase in circulating estrogens associated with obesity concluded that the increasing risk with increasing body weight is the result of the increase in estrogens and a decrease in SHBG.<sup>290,291</sup> The increased risk of breast cancer in a cohort of obese women not using hormone therapy in the Women’s Health Initiative was attributed to elevated circulating levels of insulin and biologically active estradiol, highlighting the critical role for hyperinsulinemia as discussed above.<sup>263</sup>

Bone mass is generally regarded as a marker of estrogen exposure, and women with the highest bone densities have a greater risk of breast cancer compared with women



who have low bone densities.<sup>292,293,294</sup> Another attempt to link the risk of breast cancer to the endogenous estrogen level focused on prenatal exposure. A reduced risk for breast cancer is observed for women born to mothers with pregnancy-induced hypertension, suggesting that this finding is due to the lower estrogen levels associated with preeclampsia.<sup>295,296</sup>

The biologic plausibility and epidemiologic support for a sex steroid link are impressive arguments. Whether the important factor is the total amount of estrogens or progestins, the amount of estrogen unopposed by progesterone, the amount of free (unbound) estradiol, the duration of exposure to estrogens and progestins, or some other combination is not known.

## Endogenous Progesterone

Because mitotic activity in the breast reaches its peak during the progesterone-dominant luteal phase of the menstrual cycle,<sup>297,298,299</sup> it is argued that progesterone is the key to influencing the risk of breast cancer. However, studies do not support a major role for a progestational influence. Indeed, evidence indicates that with increasing duration of exposure, progesterone can limit breast epithelial growth as it does with endometrial epithelium.<sup>14,15,16</sup> In vitro studies of normal breast epithelial cells reveal that progestins inhibit proliferation.<sup>300</sup> Human breast tissue specimens removed after the patients were treated with estradiol and progesterone indicate that progesterone inhibits in vivo estradiol-induced proliferation.<sup>14,16</sup> Women who ultimately develop breast cancer do not have different blood levels of progesterone.<sup>289,301</sup> In addition, several clinical observations would argue against progesterone as a key factor. Although there is some disagreement, most studies indicate that the high levels of estrogen and progesterone during pregnancy have no adverse impact on the course of breast cancer diagnosed during pregnancy or when pregnancy occurs subsequent to diagnosis and treatment.

## Exogenous Hormone Use

The large number of women taking or having taken oral contraceptive steroids, combined with the belief that sex steroids provoke or promote abnormal breast growth and possibly cancer, has provided a source of major concern for years. In Denmark, a recent prospective study has indicated a small increase in the risk of breast cancer associated with hormonal contraceptive users.<sup>302</sup> This study followed over 1.8 million women ages 15–49 for an average of 10.9 years, or 19.6 million person-years, to determine association between any type of hormonal birth control and development of breast cancer. They found an overall relative risk of breast cancer in women who used hormonal contraception for greater than 6 months of 1.08 (95% CI 1.03–1.13) as

compared to women who never used hormonal contraceptives. They found that the risk increased with increasing length of use of hormonal contraceptives, with women who used them for more than 10 years having a relative risk of 1.46 (95% CI 1.32–1.61). In women who used hormones for less than 1 year, the risk of breast cancer was not increased over women who never used hormones. Additionally, this study looked at the risk of developing breast cancer by hormone type. Patients who used norethindrone either alone or combined with estrogen in a pill, drospirenone with ethinyl estradiol orally, depot medroxyprogesterone acetate, and the contraceptive implant, patches, and rings did not appear to have an increased risk of breast cancer. Oral contraceptives with estrogen carrying levonorgestrel, norgestimate, desogestrel, oral contraceptives with levonorgestrel alone, and the levonorgestrel-releasing intrauterine device all appear to have a significant but modest increased risk for breast cancer development. To put this into perspective, for every 7,690 women using hormonal contraception for 1 year, there is one extra case of breast cancer.

Previous case-control studies focused on breast cancer diagnosed at a later age, varying histologic subtypes of breast cancer, and familial breast cancer in hormonal contraceptive uses and found no association. The largest case-control study is that performed by the Centers for Disease Control and Prevention, involving 4,575 American women with breast cancer, aged 35–64.<sup>303</sup> Initiation at a younger age had no impact. In this study, the risk of breast cancer was not increased in current users or past users of oral contraception. There was no adverse effect of increasing duration of use or higher doses of estrogen and no increase in risk in women with a family history of breast cancer. A multicenter, large case-control study of women younger than 55 years with breast cancer concluded that the use of oral contraceptives or postmenopausal hormone therapy either before or after diagnosis did not increase the risk of the first breast cancer or recurrent breast cancer.<sup>304</sup> This negative finding was not changed by the duration of use or age of use. Furthermore, no increase in breast cancer mortality can be detected in women who have used oral contraceptives.<sup>305,306</sup>

A team of epidemiologists from several institutions in the United States performed a case-control study of the association between oral contraceptive use and lobular and ductal breast cancer occurring in young women (under age 44), concluding that the use of oral contraceptives has no meaningful effects on breast cancer risk according to histologic subtype.<sup>307</sup> Lobular cancer is more hormonally sensitive than ductal breast cancer.

This is all to say that while clinicians should take heed of the prospective Danish study, the biggest risk in increases in breast cancer appears to be in early and recent use of oral contraceptives. It has long been a concern that studies showing this effect of hormones on a premenopausal population may affect the growth of a preexisting

malignancy. The literature we have on subpopulations, including patients with familial breast cancer, does not indicate that using hormonal birth control significantly increases their risk of developing breast cancer.<sup>308</sup>

Oral contraception appears to protect against benign breast disease. A French case-control study indicated a reduction of nonproliferative benign breast disease associated with low-dose oral contraceptives used before a first full-term pregnancy, but no effect on proliferative disease or with use after a pregnancy.<sup>309</sup> A Canadian cohort study that almost certainly reflected the use of modern low-dose oral contraceptives concluded that oral contraceptives do protect against proliferative benign disease, with an increasing reduction in risk with increasing duration of use.<sup>310</sup>

Women with a greater mammographic breast density have a higher risk of breast cancer.<sup>311</sup> If more than 75% of the breast is dense, the risk is 4–5 times increased. Mammographic density is associated with epithelial and stromal cell proliferation.<sup>312</sup> Studies in twins and families have indicated that there is a strong genetic determinant of an individual's breast density and that this genetic influence is shared with the other genetic factors that increase the risk of breast cancer.<sup>313,314,315,316</sup> In general, breast density declines with age and increasing body weight and numbers of pregnancies.

About 25% of women on estrogen-progestin therapy have an increase in their breast density. However, it is not certain that the short-term increase in density with hormone therapy changes an individual's risk of breast cancer. The increase in breast density associated with postmenopausal hormone therapy appears in some studies to be a transient, reversible change, a change not consistent with a persistent effect on cellular proliferation. After discontinuing hormone therapy, some reports indicated that breast density rapidly decreases.<sup>317,318,319,320</sup> However, in a large randomized trial of 1,704 women age 45–80, although suspension of hormone therapy for 1 or 2 months produced small but significant decreases in density, mammography recall rates of 10–12% were not affected.<sup>321</sup> In one small screening population of 47 women, a 4-week period without hormones before mammography had no measurable effect on density readings.<sup>322</sup> Therefore, the evidence is mixed regarding a recommendation to discontinue hormone therapy for 2–4 weeks prior to mammography in women who have dense breasts. Another approach is to consider lower doses of hormone therapy; there is some evidence that low-dose treatment has little effect on breast density.<sup>323</sup>

## **Thyroid, Prolactin, and Various Nonestrogen Drugs**

Despite isolated suggestions of increased risk, hypothyroidism, reserpine, and prolactin excess, whether spontaneous or drug-induced, are not associated with an enhanced risk of breast cancer.<sup>319,320</sup>

## Breast Cancer in Diethylstilbestrol-Exposed Women

From 1940 to 1970, diethylstilbestrol (DES), a potent synthetic estrogen, was prescribed in high doses in the mistaken belief that it would reduce the risk of pregnancy-related complications. Exposure to DES occurred in association with 2 million live births; therefore, the risk for induction of breast cancer during a period of breast differentiation could be significant if DES were a true breast carcinogen. The first study on this subject reported on the follow-up of women who participated in a controlled trial of DES in pregnancy between 1950 and 1952 at the University of Chicago. In this study, an increase in breast cancer risk that did not reach significance was observed with DES exposure.<sup>324</sup> A large collaborative study, involving approximately 6,000 women, concluded that there is a small but significant increase in the risk of breast cancer many years later in life in women exposed to DES during pregnancy.<sup>325</sup> In a longer follow-up (more than 30 years) of this large cohort of DES-exposed women, exposure to DES was associated with a significant, but modest (about twofold), increase in the risk of breast cancer.<sup>326</sup> Importantly, the relative risk did not increase with duration of follow-up and remained stable over time. This conclusion was confirmed in a prospective study by the American Cancer Society and in a national cohort of women followed since the 1970s.<sup>327,328</sup> Certainly, it is wise to recommend to DES-exposed women that they adhere to screening for breast cancer, including mammography as discussed later. More recently, as in utero-exposed DES daughters reach an age when breast cancer becomes more prevalent, an increased risk of cancer has been detected in daughters of DES-exposed women.<sup>329</sup> Thankfully, the relative risk is quite small and does not change the recommendations for breast screening. It will be important to track this population for further increases as they age.

# Receptors and Clinical Prognosis

There is a strong correlation between the presence of estrogen receptors and certain clinical characteristics of breast cancer.<sup>330</sup> Premenopausal, younger patients are more frequently receptor negative. Patients with receptor-positive tumors survive longer and have longer disease-free intervals after mastectomy than those with receptor-negative tumors. The presence of estrogen receptors correlates with increased disease-free interval regardless of the size and location of the tumors. Similarly, patients with estradiol receptor–negative tumors were noted to have the same high rate of recurrence as patients with axillary lymph node metastases. Patients with tumors that are positive for estrogen receptors are more likely to respond to endocrine treatment. Estrogen receptor status correlates with the degree of differentiation of the primary tumor. A large proportion of highly differentiated grade I carcinomas are receptor positive, while the reverse is true of grade III tumors.

Remember that estrogen stimulates the production of progesterone receptors. Overall, about 80% of breast cancers are positive for estrogen receptors, and of these, about 70% are positive for progesterone receptors; thus, about 58% of all breast cancers express both estrogen and progesterone receptors.<sup>331</sup> The best prognosis is seen in patients with positive progesterone receptors, even with subsequent disease if the recurrent disease is still progesterone receptor–positive. The loss of progesterone receptors is an ominous sign. Tumors that are estrogen receptor–positive, but progesterone receptor–negative, express higher levels of the epidermal growth factor receptors, HER-1 and HER-2, and are more aggressive and tamoxifen-resistant.<sup>331</sup> The total absence of estrogen and progesterone receptors indicates a very different disease, one that should be treated aggressively with chemotherapy.

# Hormone Therapy of Breast Cancer

## Tamoxifen

The purpose of adjuvant therapy of breast cancer is to provide treatment in the absence of recognized active disease in order to reduce the risk of future recurrence or to minimize systemic recurrence in the presence of metastatic disease. Tamoxifen is very similar to clomiphene (in structure and actions), both being nonsteroidal compounds structurally related to DES. In vitro, the estrogen binding affinity for its receptor is 100–1,000 times greater than that of tamoxifen. Thus, tamoxifen must be present in a concentration 100–1,000 times greater than estrogen to maintain inhibition of breast cancer cells. Dose-response studies with tamoxifen have failed to demonstrate an increase in activity with doses larger than the standard, 20 mg daily. When bound to the estrogen receptor, tamoxifen prevents gene transcription by the TAF-2 pathway. In vitro studies demonstrate that these actions are not cytotoxic, but rather cytostatic (and thus tamoxifen use must be long term). The mechanism of tamoxifen action is discussed in detail in [Chapter 1](#).

We have available a remarkable worldwide overview of 37,000 women involved in tamoxifen randomized trials.<sup>332</sup> Adjuvant treatment with the antiestrogen tamoxifen achieved highly significant reductions in recurrence and increases in survival. The beneficial effect of tamoxifen was evident no matter what the age of the patient, in both premenopausal and postmenopausal women, in node-positive and node-negative disease, and in both estrogen receptor–positive and estrogen receptor–negative tumors (however, the effect of tamoxifen on estrogen receptor–negative tumors is small). The impact on recurrence occurred in the first 5 years, but continued impact on survival occurred throughout 15 years.<sup>333</sup> Hormonal adjuvant treatment yields worldwide an extra 100,000 10-year survivors. With tamoxifen, there is an increased survival at 5 years of approximately 25%, most evident in women over age 50. Response rates in advanced breast cancer are 30–35%, most marked in patients with tumors that are positive for estrogen receptors, reaching 75% in tumors highly positive for estrogen receptors. There is a lower rate (a 47% reduction with 5 years of treatment) of a second primary breast cancer in the contralateral breast in women treated with tamoxifen.

Data from randomized clinical trials document that a treatment duration of 5 years is superior to 2 years.<sup>334</sup> It was previously thought that there was little reason to extend tamoxifen treatment of breast cancer patients beyond 5 years.<sup>335,336</sup> The data suggested that survival and recurrence rates worsened with longer therapy, probably due to the emergence of tamoxifen-resistant tumors. However, a randomized placebo-controlled trial looked at women with estrogen receptor–positive early breast cancer who had

completed 5 years of tamoxifen therapy and were considered disease-free, and these patients were randomized to either placebo or additional tamoxifen for 5 years.<sup>337</sup> In this study, it was found that women receiving 10 years of tamoxifen had fewer recurrences (relative risk after year 10 was 0.75, 95% CI was 0.62–0.9), lower breast cancer mortality (relative risk after year 10 was 0.71, 95% CI 0.58–0.88), and a lower overall mortality than women who received placebo (relative risk 0.87, 95% CI 0.78–0.97). The risk of pulmonary embolus and endometrial cancer was significantly higher in the tamoxifen continuation group, while the risk of ischemic heart disease was significantly lower.

The efficacy of tamoxifen is significantly dependent on the formation of active metabolites, 4-hydroxytamoxifen and endoxifen, which have a greater affinity for the estrogen receptor than tamoxifen. A cytochrome enzyme, P450 2D6, is involved in this metabolism, and genetic variants in the enzyme can account for lower activity leading to reduced efficacy for tamoxifen. Genotyping of CYP2D6 could allow better selection of patients for tamoxifen treatment.<sup>338</sup> However, others contend that the metabolite levels are sufficient for good efficacy even in the presence of reduced enzyme activity and that the studies linking CYP2D6 genotype and breast cancer recurrence have yielded heterogeneous results.<sup>339</sup> It is not certain that CYP2D6 variation is the explanation for recurrence of resistant tumors.

Tamoxifen has many important side effects, attributed to both its estrogen agonist action and its antiestrogen impact in different target tissues. The major disturbing side effect is an increase in hot flushing. The serious side effects of tamoxifen include endometrial cancer (discussed later), venous thrombosis, and cataracts. In a report from the prevention trial in England and in the US preventive trial, tamoxifen treatment of postmenopausal women prevented bone loss, but premenopausal women treated with tamoxifen had significant reductions in bone mineral density.<sup>234,340</sup> Blurred and decreased vision has been reported associated with retinal changes.<sup>341</sup> In a prospective study of 63 patients in Greece, 6.3% developed retinopathy, which was reversible except for retinal opacities.<sup>342</sup> In the 2,673 patients in the protocols of the Eastern Cooperative Oncology Group, premenopausal women who received tamoxifen and chemotherapy had significantly more venous and arterial thrombosis than those who received chemotherapy without tamoxifen, and in postmenopausal women, tamoxifen alone was associated with more venous thrombosis.<sup>343</sup>

Serum protein changes reflect the estrogenic (agonistic) action of tamoxifen. This includes decreases in antithrombin III, cholesterol, and LDL cholesterol, while HDL cholesterol and SHBG levels increase (as do other binding globulins). Because of the significant impact on SHBG, a marked increase in circulating estrogens has been observed in premenopausal women; however, unbound, free estrogen is actually

reduced. For example, in a clinical study of premenopausal women receiving tamoxifen, 20 mg daily, the percent free estradiol decreased from 1.72% to 1.47% after 3 months because of the increase in SHBG.<sup>344</sup>

The estrogenic activity of tamoxifen, 20 mg daily, is nearly as potent as 2-mg estradiol in lowering FSH levels in postmenopausal women, 26% versus 34% with estradiol.<sup>345</sup> The estrogenic actions of tamoxifen include the stimulation of progesterone receptor synthesis, an estrogen-like maintenance of the bone and the cardiovascular system, and estrogenic effects on the vaginal mucosa and the endometrium. Indeed, patients with breast cancer who have been treated with tamoxifen were reported to have less coronary heart disease in some studies, but not all.<sup>234,332,346,347</sup> Tamoxifen increases the frequency of hepatic carcinoma in rats at very large doses. This is consistent with its estrogenic, agonistic action, but this effect is unlikely to be a clinical problem, and it has not been observed at doses used clinically.<sup>332</sup>

## Gynecologic Problems with Tamoxifen

Tamoxifen is selective estrogen receptor modulator, having both estrogen receptor antagonist and agonist properties, depending on the tissue and genes examined. A tissue that is highly sensitive to estrogen, the endometrium, responds to the weak estrogenic action of tamoxifen, which is present in high doses for long durations in women receiving adjuvant treatment for breast cancer.

The National Surgical Adjuvant Breast and Bowel Project compared the rates of endometrial cancers in tamoxifen and non-tamoxifen-treated patients who had breast cancer.<sup>348</sup> The rate of endometrial cancer in the tamoxifen-treated group equaled an increased relative risk of 7.5. Although 88% of the endometrial tumors were stage I, four patients died of advanced endometrial cancer. It is worth noting that the incidence of endometrial cancer in the tamoxifen-treated group was estimated to be 6.3 per 1,000 patients after 5 years of treatment. This incidence is very similar to what would be expected with unopposed estrogen treatment, a similarity to be expected in that the agonistic estrogenic action of tamoxifen over the long term should be similar to the relatively low doses of estrogen used for postmenopausal hormone therapy. Similar results were reported from the Stockholm tamoxifen trial, and an increased rate of postmenopausal endometrial cancer was confirmed in the U.S. Breast Cancer Prevention Trial.<sup>234,349</sup> In the world overview of randomized trials, the incidence of endometrial cancer quadrupled with 5 years of tamoxifen treatment.<sup>332</sup> In addition, women being treated with tamoxifen were reported to develop atypical hyperplasia of the endometrium, endometrial polyps, ovarian cysts, growth of fibroids, adenomyosis, and rapid exacerbation of endometriosis.<sup>350,351,352,353</sup> The proper prevention, surveillance, and management of women being treated with tamoxifen are critical



problems.

It is inappropriate to advocate oral progestational treatment to prevent the endometrial response to tamoxifen. The progestational impact (at the low doses currently used for endometrial protection) on the risk of breast cancer recurrence and the interaction with tamoxifen are not known. Indeed, a relatively high dose of norethindrone (2.5 mg daily for 3 months) was **unable** to exert a protective effect on the endometrium in healthy women participating in the U.K. tamoxifen prevention trial, and a high dose of megestrol acetate failed to reverse endometrial hyperplasia.<sup>354,355</sup> **The levonorgestrel intrauterine device (IUD) effectively effectively protects the endometrium against hyperplasia and polyps in women using tamoxifen or postmenopausal estrogen therapy.**<sup>356,357,358,359,360,361,362,363,364</sup> **Breakthrough bleeding is a problem in the early months, but this method is suitable for both premenopausal and postmenopausal women using tamoxifen. This IUD can also be used to treat endometrial hyperplasia.**<sup>365,366,367,368,369,370</sup> **However, the persistence of atypia at biopsy follow-up after 6 months is an indication that regression is unlikely to occur. Although the levonorgestrel IUD confidently provides good protection against endometrial hyperplasia, clinicians should maintain a high degree of suspicion of unusual bleeding (bleeding that occurs after a substantial period of amenorrhea) and aggressively assess the endometrium.**

Most tamoxifen-treated women who have developed endometrial cancer have been symptomatic with vaginal bleeding, but not all. Vaginal bleeding in tamoxifen users should always prompt uterine evaluation. Unfortunately, some women with amenorrhea have had advanced, invasive uterine disease. Stage III and stage IV endometrial cancers with a poor prognosis were reported more frequently in long-term tamoxifen users.<sup>371</sup> In addition, tamoxifen is associated with a higher rate of mixed mesodermal tumors and sarcomas of the endometrium.<sup>371</sup> It makes sense to detect abnormal changes as early as possible, but an ideal surveillance method had eluded clinicians. The progestin challenge test may be a cost-effective method to detect the presence of stimulated endometrium, and small prospective studies reported 100% sensitivity and positive predictive value for endometrial pathology.<sup>372,373</sup> Periodic transvaginal ultrasound using a cutoff endometrial thickness of 9 mm has been studied as a surveillance method, and it has been shown to be ineffective at identifying endometrial cancer in this patient population with a sensitivity of 63%, specificity of 60%, and positive predictive value of only 1.4%.<sup>374</sup> The use of ultrasonographic measurement of endometrial thickness, with saline instillation sonohysterography when the appearance is not totally benign, may be used. In a retrospective study using endometrial thickness cutoffs of 9.5 mm on regular ultrasonography and 5.5 mm on saline sonography yielded sensitivities of 89% and 78% and specificities of 78% and 84%. When using either the presence of polypoid

lesions or endometrial thickness of 5.5 mm or greater on saline sonography, sensitivity increased to 100%.<sup>375</sup> Tamoxifen is associated with an ultrasonographic image that is unique, characterized by sonolucent changes that are subepithelial in the presence of atrophic epithelium, thus the usefulness of saline instillation to discriminate epithelial thickness from combined endometrial changes.<sup>376</sup> Periodic endometrial aspiration biopsy would likely be sufficient for surveillance, but this procedure carries with it the potential for a very significant negative effect on patient compliance (with her tamoxifen and with her clinician) and a low rate of positive results.

It is also logical to expect patients on tamoxifen to be at increased risk for the development and progression of endometriosis. There are case reports of women being treated with tamoxifen, 20 mg daily, who required hysterectomy and oophorectomy for severe endometriosis.<sup>377,378,379,380</sup> In addition, women receiving tamoxifen develop adenomyosis, ovarian cysts, and endometrioid cancer of the ovary.<sup>380,381,382,383</sup> In our view, an annual pelvic examination is not sufficient; every 6 months is best.

A woman being treated for breast cancer will naturally focus her attention and energy on the cancer itself, especially in the early years of treatment. The same can be said for the specialist who is monitoring the treatment. It falls to the patient's health care manager, her primary clinician, to look at the broader picture. A clinician interacting with patients being treated for breast cancer has an obligation to consider the impact of the patient's treatment on other body systems and functions. Tamoxifen offers the hope of adding many years to a woman's life. Medical intervention by a clinician can help make those years better with good preventive health care.

# Aromatase Inhibitors for the Treatment of Breast Cancer

Aromatase inhibitors block the conversion of androgen precursors to estrogen at all target tissue sites, nearly completely inhibiting total body estrogen production in postmenopausal women. This inhibition is not as complete in premenopausal women. The modern aromatase inhibitors include two nonsteroidal inhibitors, anastrozole (Arimidex) and letrozole (Femara), and one steroidal inactivator, exemestane (Aromasin).

The aromatase enzyme is present in the stromal tissue of normal and abnormal breast tissue and in breast epithelial cells. Aromatase activity is increased in breast cancer tissues, associated with a switch from a promoter controlled primarily by glucocorticoids and cytokines to a promoter regulated through cyclic AMP pathways.<sup>384</sup> However, aromatase activity in malignant breast epithelial cells is either undetectable or very low. Thus, growth stimulation of hormonally sensitive breast cancer is presumed to be influenced by local estrogen synthesis in adjacent stromal cells that is increased in a paracrine fashion by malignant cells activating alternative aromatase gene promoters.<sup>385</sup> A relationship between the aromatase and prostaglandin cyclooxygenase systems may explain the beneficial effects of nonsteroidal anti-inflammatory drugs in epidemiologic reports on the risk of breast cancer.<sup>386</sup> Cyclooxygenase is overexpressed in breast cancer, and the treatment combination of aromatase and cyclooxygenase inhibitors is being evaluated in clinical trials.<sup>387</sup>

The specific inhibitors of P450arom that have been developed produce intense blockage of estrogen production and, importantly, reduce estrogen biosynthesis in the cells adjacent to breast tumors. The initial development of drugs that reduce estrogen production focused on alterations of the androstenedione molecule to produce competitive inhibitors. The preparation of a large number of altered steroid agents yielded exemestane, a steroidal inactivator of the aromatase enzyme, that clinically is grouped in the family of aromatase inhibitors.

The first nonsteroidal inhibitors, such as aminoglutethimide, affected other CYP-450 enzymes, producing unwanted toxic effects. The current generation of nonsteroidal aromatase inhibitors containing a triazole ring, anastrozole and letrozole, are highly specific with no effect on the biosynthesis of other steroids. These agents are 100–3,000 times more potent than aminoglutethimide and reduce total body aromatization by 97–99%.<sup>388</sup>

The first studies with the nonsteroidal aromatase inhibitors demonstrated that anastrozole (1 mg daily) and letrozole (2.5 mg daily) were more effective than

tamoxifen in women with advanced breast cancer.<sup>389,390,391</sup> Similar results were reported with exemestane.<sup>392</sup> More recent clinical trials focused on the treatment of early breast cancer.

**The ATAC Trial.**<sup>393,394,395</sup> The Arimidex, Tamoxifen, Alone or in Combination trial included 9,366 patients in 380 sites in 23 countries. Eighty-four percent had estrogen receptor–positive tumors and one-third had positive lymph nodes. The patients were randomized to daily treatment with anastrozole, 1 mg; tamoxifen, 20 mg; or a combination of both for 5 years.

Compared with tamoxifen, anastrozole increased the disease-free survival by 14%, decreased the incidence of new contralateral primary tumors by 38% (although this difference did not reach statistical significance), and increased the time to recurrence by 17%. The combination treatment was not better than anastrozole alone. In patients negative for estrogen and progesterone receptors, the small effect of anastrozole was equivalent to that of tamoxifen. After long-term follow-up, it was apparent that the carryover effect after 5 years of treatment was greater with anastrozole compared with tamoxifen.<sup>395</sup>

There were significant differences in comparing the adverse effects of the two drugs (Table 16.9).

## **TABLE 16.9 Side Effects of Hormone Therapies for Breast Cancer**

	Anastrozole (%)	Tamoxifen (%)
Hot flushes	34.3	39.7
Vaginal bleeding	4.5	8.2
Endometrial cancer	0.1	0.5
Venus thromboembolism	2.1	3.5
Joint complaints	27.8	21.3
Fractures	5.9	3.7

Adverse gynecologic events occurred less frequently with anastrozole compared with tamoxifen in the ATAC trial.<sup>396</sup> These events included lower incidences of vaginal hemorrhage, vaginal discharge, endometrial polyps, endometrial hyperplasia, and endometrial cancer. As a result, there was a fourfold increase in hysterectomy in the women treated with tamoxifen. Importantly, more women remained adherent to treatment with anastrozole.

**The BIG Trial.** The Breast International Group trial randomized 8,028 women to either tamoxifen or letrozole for 5 years and reported an improved disease-free survival in the letrozole group.<sup>397,398</sup>

**The ITA Trial.** The Italian Tamoxifen Anastrozole Trial of 448 women compared 5 years of tamoxifen to a group switched to anastrozole after 2–3 years of tamoxifen.<sup>399</sup> The disease-free survival was significantly increased in the sequentially treated group.

**The IES Trial.** The Intergroup Exemestane Study included 4,742 patients and compared 5 years of tamoxifen with a sequential group switched to exemestane, 25 mg daily, after 2–3 years of tamoxifen.<sup>400,401</sup> There was a 32% reduction in risk with exemestane for recurrence, contralateral breast cancer, or death that equaled an improvement of 4.7% in disease-free survival. The risk of contralateral breast cancer was reduced by 56%.

**The TEAM Trial.** The Tamoxifen Exemestane Adjuvant Multinational Study randomized 9,775 women to either exemestane, 25 mg daily, or tamoxifen, 20 mg daily.<sup>402</sup> In 2004, the trial was modified, switching tamoxifen patients to exemestane after 2.5–3 years of treatment to complete 5 years of treatment total. After 10 years of follow-up, there was no difference in disease-free survival.<sup>403</sup>

**The MA.17 Trial.** After 5 years of tamoxifen treatment, 5,187 women were randomized to 5 years of letrozole or placebo.<sup>404,405</sup> The analysis indicated an improvement in disease-free survival with letrozole, 94.3% compared to 91.4% in the placebo group. This impact was present in both patients with positive nodes and negative nodes. Overall, the letrozole group experienced a 39% reduction in contralateral primary breast cancer, a 42% reduction in recurrences, and a 38% reduction in distant metastases. Because of these benefits, the trial was unblinded and patients were given the option of switching from placebo to letrozole. In an updated analysis, disease-free survival was improved with letrozole treatment.<sup>406,407</sup> This study reported significantly more joint complaints and more hot flushing compared with placebo and an increase in fractures and cardiovascular events.

Aromatase inhibitors are more effective than tamoxifen for the treatment of estrogen-sensitive breast cancers in postmenopausal women, either for early disease or for metastatic breast cancer. The three aromatase inhibitors have similar side effect profiles. The major problem has been an increase in fractures due to the bone loss associated with the profoundly low estrogen levels (nearly a 99% decrease), an effect that can be prevented with bisphosphonate treatment. Besides hot flushing, other major side effects are joint arthralgias, reduced sexual function, and myalgia.<sup>408</sup> Compared with tamoxifen, there is less, if any, endometrial stimulation and less venous thromboembolism. Anecdotal experience has suggested that anastrozole users have an increased prevalence of retinal hemorrhages, presumably due to vascular fragility secondary to estrogen depletion.<sup>409</sup>

A decision analysis using computer modeling suggested that a modestly improved outcome is associated with sequential therapy (tamoxifen for 2.5 years followed by an aromatase inhibitor) compared with 5 years of an aromatase inhibitor alone. The actual increase was only 1–2%.<sup>410</sup> This small difference was not supported by a phase 3 clinical trial, a continuation of the BIG trial, comparing letrozole monotherapy with tamoxifen-letrozole sequential therapy, in which the overall survival in the treatment groups did not differ.<sup>411</sup>

The American Society of Clinical Oncology and the National Comprehensive Cancer Network, based on the results of the clinical trials, now make the following recommendations<sup>405,412</sup>:

- Postmenopausal women with hormone-positive breast cancers should be treated with an aromatase inhibitor for 5–10 years, tamoxifen for 5–10 years, or tamoxifen for 5 years followed by 5 years of aromatase inhibitor treatment.
- Premenopausal women with hormone-positive breast cancers should be treated with tamoxifen for 5–10 years, with the option of switching to an aromatase inhibitor after 5 years if the patient becomes postmenopausal during treatment.
- Aromatase inhibitors are appropriate as initial treatment for women with contraindications to tamoxifen.
- Aromatase inhibitor treatment has been associated with better response rates compared with tamoxifen in postmenopausal women with tumors overexpressing HER-2. This evidence is not strong but should be considered.
- There is insufficient evidence available to support the use of tamoxifen after treatment with an aromatase inhibitor.

A reasonable and important addition to these recommendations is to promote adequate calcium and vitamin D supplementation and to consider prophylactic bisphosphonate treatment to prevent bone loss and fractures. Treatment with zoledronic acid (4 mg intravenously every 6 months) increased bone density in women being treated with letrozole and even improved disease-free survival rates.<sup>413,414</sup> Similar bone density results were obtained with the once-a-month oral bisphosphonate, ibandronate.<sup>415</sup> **More effective protection against bone loss and fractures is achieved by starting bisphosphonate treatment simultaneously with an aromatase inhibitor.**<sup>416</sup>

Bisphosphonates appeared to have an independent beneficial impact on the incidence of breast cancer in observational studies. In the Women's Health Initiative, oral bisphosphonate users had a significant 32% reduction in estrogen receptor–positive breast cancer incidence.<sup>417</sup> However, randomized controlled trials looking at 3–4 years of bisphosphonate use in women ages 55–89 showed no difference in the risk of developing breast cancer.<sup>418</sup>

A meta-analysis of randomized trials looking at 19,818 patients comparing aromatase inhibitors with tamoxifen in early breast cancer focused on cardiovascular risk.<sup>419</sup> The relative risk for grade III and IV cardiovascular adverse events with aromatase inhibitors as compared to tamoxifen was unexpectedly 1.31 (CI = 1.07–1.60). However, there was a 47% reduced risk of thromboembolic events with aromatase inhibitors, RR = 0.53 (CI = 0.42–0.65). Additionally, a meta-analysis of randomized controlled trials looking at 16,349 patients comparing extended aromatase inhibitor therapy with placebo in patients with early breast cancer showed an increase in relative risk of cardiovascular events of 1.18 (95% CI = 1.0–1.4).<sup>420</sup>

The increase in cardiovascular disease with aromatase inhibitors reflects the

absence of a beneficial influence of estrogen on the lipid profile and on important vascular epithelial functions such as nitric oxide synthesis. The meta-analyses suggest that this is a relatively low risk. Furthermore, it is inadvisable to consider only one of the estrogen deficiency side effects. The overall impact on a patient will be determined by the additive effects on all estrogen target tissues. The effects on cognition and the risk of Alzheimer disease are major potential issues. Cognitive assessments were performed in a subgroup of women in the IBIS anastrozole trial for prevention of breast cancer; no significant differences were observed comparing the treatment group with the placebo group; however, the duration of the study was only 2 years.<sup>421</sup> Another study reported worse verbal and visual learning in women treated with anastrozole compared with tamoxifen treatment.<sup>422</sup> Dutch women in the TEAM trial who were tamoxifen users performed worse than healthy controls on verbal memory and executive function testing, whereas no adverse effects were observed in exemestane users after 1 year.<sup>423</sup> Continuing follow-up of treated women over a longer period of time will be necessary to acquire a better understanding of the impact of aromatase inhibitors on cognition.

Some important questions regarding aromatase inhibitors remain unanswered. The optimal duration of therapy is not established. At the present time, treatment longer than 5 years awaits appropriate clinical trial data. The long-term safety is unknown; will a low estrogen and a relatively high androgen hormonal environment lead to clinical consequences? Balancing the benefits and risks will require this information. Nevertheless, aromatase inhibitor treatment has justifiably usurped the place of tamoxifen in the adjuvant treatment of breast cancer; the reason being that it is more effective to pharmacologically block estrogen biosynthesis, especially at the local level, than it is to interfere with estrogen action.



# Tamoxifen, Raloxifene, and Aromatase Inhibitors for Prevention of Breast Cancer

## Tamoxifen

Women at increased risk for breast cancer participated in a breast cancer prevention trial initiated in the United States in 1992. The study compared two groups of women, one treated with placebo and one with 20-mg tamoxifen daily for 5 years. Early in 1998 (after about 4 years of follow-up), the study was unblinded because there were 49% fewer cases of invasive breast cancer and 50% fewer cases of noninvasive breast cancer in the tamoxifen-treated arm of the study.<sup>232</sup> This outcome was not without risk. There was a 2.4-fold increase in postmenopausal endometrial cancer, a 2.8-fold increase in pulmonary embolism, a 1.6-fold increase in venous thrombosis, and a 1.6-fold increase in cataracts.

There have been four randomized placebo-controlled tamoxifen prevention trials. In the 7-year follow-up report of the American tamoxifen for prevention study, the risk for breast cancer was 0.57 (CI = 0.46–0.79), a 43% reduction, not the 50% cited in the results above, and the risk for in situ disease was 0.63 (CI = 0.45–0.89), a 37% reduction.<sup>233</sup> Follow-up of the Italian national trial demonstrated a 23% reduction of estrogen receptor–positive cancers in the group of women considered to be at the highest risk of cancer.<sup>424</sup>

The Royal Marsden randomized, double-blinded tamoxifen breast cancer prevention trial began in 1986, enrolling 2,494 women with a positive first-degree family history of breast cancer.<sup>425</sup> The treatment group received 20 mg tamoxifen daily for 8 years. Twenty years later (median follow-up of 13 years), there were 139 estrogen receptor–positive breast cancers for a 39% reduction (HR = 0.61, CI = 0.43–0.86). The lowered risk did not become statistically significant until after the 8-year treatment period.

The International Breast Cancer Intervention Study (IBIS), also a randomized, double-blinded trial, began in 1992 and enrolled 7,145 women; the treatment period with tamoxifen 20 mg daily was 5 years.<sup>426</sup> After a median follow-up of 8 years, there was a 34% reduction in estrogen receptor–positive cancers (RR = 0.66, CI = 0.50–0.87). The IBIS trial found a greater reduction during the treatment period, but when the analysis was restricted to estrogen receptor–positive cancers, the IBIS and Royal Marsden trials were similar, finding a greater effect after treatment. The differences among these trials are attributed to variations in risk factors in the studied populations. The American trial enrolled women with risk assigned by the Gail model, a risk

assessment tool for invasive breast cancer that has been validated in white women.<sup>427</sup> The women in the International trial were at a lower risk than those in the Royal Marsden trial, and the women in the Italian trial were not assessed for risk.

Epidemiologists from England, Italy, and Australia reviewed the combined results of the breast cancer tamoxifen prevention trials and added updated results.<sup>428</sup> The combined data indicated a 48% reduction in estrogen receptor–positive cancers and no effect on the incidence of estrogen receptor–negative cancers. The overall relative risk of endometrial cancer with tamoxifen was increased 2.4-fold, and the relative risk of venous thromboembolic events was 1.9. The length of follow-up and patient numbers do not allow data regarding breast cancer mortality. The impact of 5 years of tamoxifen treatment on 1,000 high-risk women should yield an 18% reduction in mortality within 10 years of diagnosis. Experts and organizations in the breast cancer world have agreed that tamoxifen reduces the incidence of estrogen receptor–positive cancers in high-risk women. In an assessment of the women in the American preventive trial, tamoxifen reduced the incidence of breast cancer among BRCA2 carriers, but not in BRCA1 carriers, perhaps reflecting the fact that most of the BRCA2 carriers have estrogen receptor–positive tumors in contrast to the prevalence of estrogen receptor–negative tumors in BRCA1 carriers (another problem was small numbers, 8 with BRCA1 mutations and 11 with BRCA2 mutations).<sup>429</sup>

The evidence supports tamoxifen reduction of the risk for estrogen receptor–positive breast cancer, but at the same time, tamoxifen should be recommended as a preventive agent only for women at very high risk. This conclusion is based upon the degree of reduction in risk compared with the incidence of side effects. An evaluation by the National Cancer Institute is very helpful.<sup>430,431</sup> Because the risks associated with tamoxifen (endometrial cancer, stroke, pulmonary embolism, and deep vein thromboembolism) increase with age, balancing the risks and benefit indicates that tamoxifen is best for younger women with an elevated risk of breast cancer (an increased relative risk of approximately 1.7). A similar conclusion was reached by a working group of the American Society of Clinical Oncology.<sup>432</sup> This means that only a relatively small number of women qualify, about 5% of American white women and 0.6% of black women.<sup>430</sup>

There is one lingering concern. There has been a slight increase in estrogen receptor–negative cancers in the follow-up period after treatment in all of the prevention trials. It is uncertain if this is related to tamoxifen exposure; however, in the trials assessing tamoxifen treatment of breast cancers, survival and recurrence rates worsened with longer therapy, probably due to the emergence of tamoxifen-resistant tumors.

In conclusion, tamoxifen exposure for 5–8 years is associated with about a 30–50%

reduction in estrogen receptor–positive breast cancers for at least 15 years after the treatment ends. An estimate of the absolute impact puts this in better perspective. The absolute reduction in cumulative overall incidence of breast cancer after 5 years is estimated to about 1.1% and after 10 years 1.7%. This small impact, combined with the serious side effects, has made tamoxifen treatment an unattractive option.

## Raloxifene

The MORE trial, the Multiple Outcomes of Raloxifene Evaluation trial, was a randomized, double-blind, multicenter clinical study of postmenopausal women with osteoporosis that reported a 72% reduction in estrogen receptor–positive invasive breast cancer in the treatment group after 4 years compared with placebo.<sup>433</sup> The CORE trial, the Continuing Outcomes Relevant to Evista trial, was designed to measure the impact of 4 additional years of raloxifene (60 mg/day), to begin during the fourth year of the MORE trial.<sup>434</sup> Of the 7,705 participants initially randomized in the MORE trial, 3,510 women elected to continue raloxifene treatment (2,336 completed the CORE trial) and 1,703 continued on placebo (1,106 completed the trial). During the 4-year CORE study, raloxifene treatment was associated with a 66% (HR = 0.34, CI = 0.18–0.66) reduction of estrogen receptor–positive invasive breast cancers in the treated group. There was no difference in estrogen receptor–negative tumors. Over the entire 8-year period, the reduction in estrogen receptor–positive cancers reached 76%. In the 8-year period, there was no difference in the number of deaths in the two groups.

The Study of Tamoxifen and Raloxifene (STAR) trial enrolled 19,747 women at increased risk of breast cancer who were randomized to treatment with either raloxifene, 60 mg daily, or tamoxifen, 20 mg daily, in more than 500 centers in the United States, Canada, and Puerto Rico.<sup>435</sup> The reported results after an average treatment period of almost 4 years were as follows<sup>435</sup> (Table 16.10).

### TABLE 16.10 STAR Trial Results

	<b>Raloxifene (9,745 Women)</b>	<b>Tamoxifen (9,726 Women)</b>
Invasive breast cancer	167 cases	163 cases
Breast cancer in situ	81	57
Deep venous thrombosis	65	87
Pulmonary embolus	35	54
Strokes	51	53
Fractures	96	104
Cataracts	313	394
Uterine cancer	23	36

The numbers of invasive breast cancers were identical in the two groups of women. It was estimated that these results were equivalent to about a 50% reduction (based on the previous results in the tamoxifen prevention trial),<sup>232,233</sup> but without a placebo arm, an accurate assessment was impossible. Thus, raloxifene appears to achieve the same reduction as tamoxifen in invasive breast cancers with a lesser increase in venous thrombosis and perhaps no increase in cataracts and uterine cancer. “Quality of life” was said to be the same for both drugs.

The fracture rates in the hip, wrist, and spine in the STAR trial were similar in the two groups. In the 7-year follow-up report of the U.S. Breast Cancer Prevention Trial with tamoxifen, osteoporotic fractures were reduced by 32%; compared with placebo, there were 11 fewer hip fractures, 13 fewer spinal fractures, and 9 fewer fractures of the radius.<sup>233</sup> However, even after 8 years of follow-up of the raloxifene trial involving women with osteoporosis, no effect of raloxifene has been evident on nonvertebral fractures.<sup>436</sup> A similar fracture rate in the STAR trial with the two treatments must

reflect the incidence of spinal fractures. Neither tamoxifen nor raloxifene can achieve the efficacy in preventing all fractures well-proven with both hormone therapy and bisphosphonate treatment. Raloxifene's lack of effect on the risk of hip fractures makes it less advantageous than tamoxifen for bone protection.

The rate of strokes was equivalent in the two treatment arms of the STAR trial. The rate of stroke was increased by 42% in the tamoxifen prevention trial (but this did not achieve statistical significance).<sup>233</sup> This is a serious risk for both drugs.

## Aromatase Inhibitors

Exemestane has been studied as a breast cancer prevention method in postmenopausal women at risk for breast cancer.<sup>437</sup> After 3 years of follow-up, this randomized control study has shown a 65% relative reduction in the annual incidence of invasive breast cancer, which is statistically significant, with no increased risk of adverse event including fracture or cardiovascular event. A randomized trial has also been completed with anastrozole.<sup>235</sup> After 5 years of follow-up, the hazard ratio is 0.47. A third study (STELLAR) has been proposed, comparing letrozole and raloxifene.<sup>438</sup> The MAP1 randomized trial evaluated the effect of letrozole treatment on breast density; no effect on breast density was observed after 1 year of treatment.<sup>439</sup> The French Onco-03/LIBER trial is assessing the use of letrozole in BRCA mutation carriers.

## Summary

These results lead us to recommend tamoxifen prophylaxis (20 mg daily for 5 years) or raloxifene prophylaxis (60 mg daily for 5 years) for those women who are diagnosed with carcinoma in situ of the breast or who have atypical hyperplasia in a breast biopsy (especially if a positive family history of breast cancer is also present). For others who seek preventive treatment, we advise that the final answers are not in and that clinical trial results from long-term follow-up will be necessary before fully informed decision-making is possible. Women at very high risk for breast cancer who choose tamoxifen or raloxifene treatment deserve support and appropriate surveillance. Bisphosphonate treatment is recommended to prevent bone loss and gain the added benefit of a further reduction in breast cancer risk.

# Vasomotor Symptoms with Tamoxifen and Aromatase Inhibitors in Breast Cancer Survivors

The problem of hot flushing should not be underrated. Women have vasomotor symptoms on tamoxifen, raloxifene, and aromatase inhibitors, and those that already had flushing sometimes have worse flushing. Various treatments are available, discussed in [Chapter 17](#).

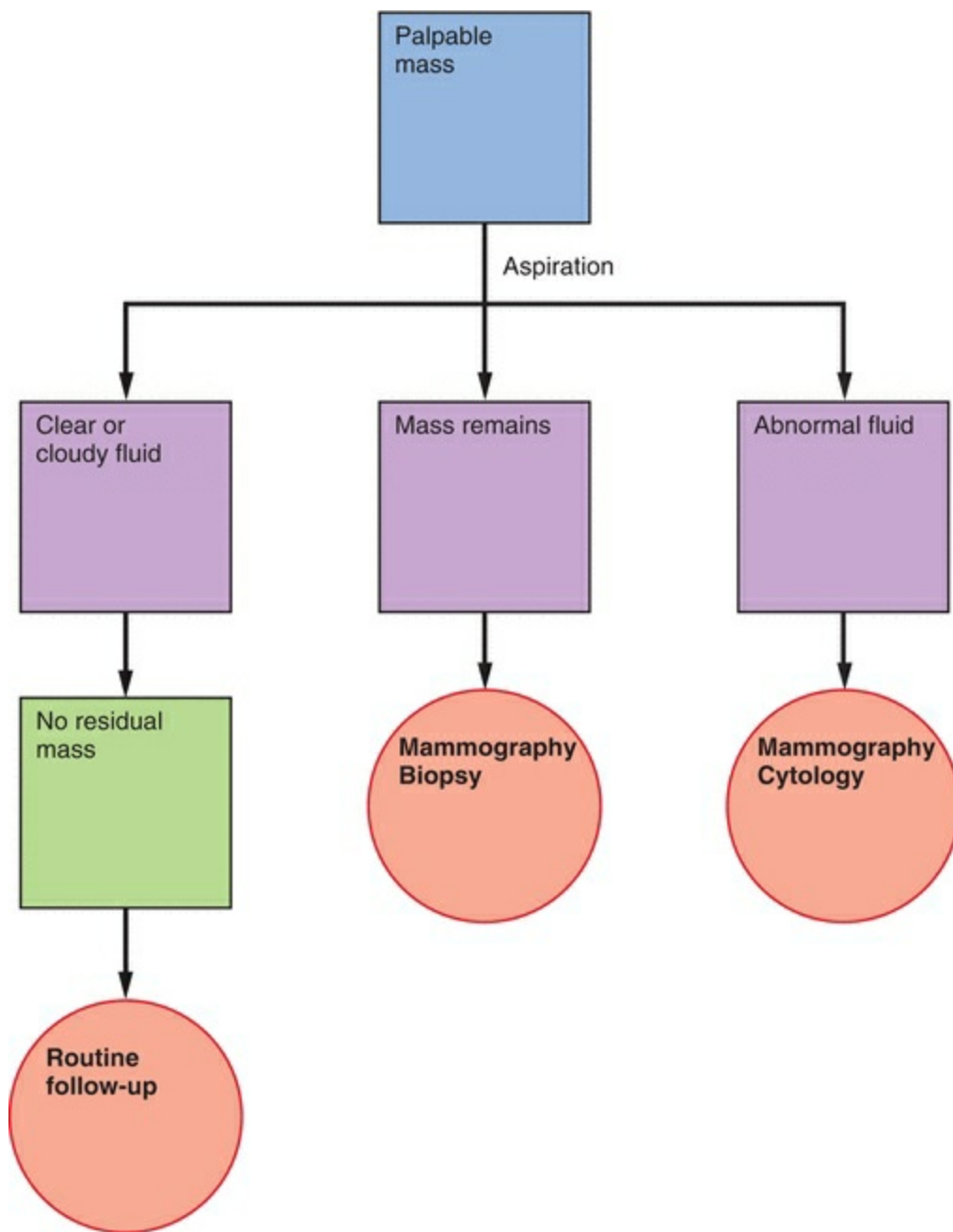
The SSRIs are the best choice after hormone therapy. It is worth trying to titer the dose down to its lowest effective level because of a low but bothersome incidence of decreased libido. In addition, clinical experience indicates that it is best to slowly titrate upward to the recommended dose and, likewise, to wean the patient slowly when discontinuing treatment. SSRIs are effective for flushing secondary to both tamoxifen and hypoestrogenemia, and the efficacy is similar in women with and without breast cancer.<sup>440</sup> An added advantage of the SSRIs is the fact that the clinical studies have also reported improvements in depression, anxiety, and sleep.

There is a concern that is of potential clinical importance. Tamoxifen is converted to an active metabolite by enzymes that are inhibited by SSRIs. Paroxetine coadministration decreases plasma concentrations of the active metabolite.<sup>441,442</sup> A lesser effect is associated with fluoxetine and sertraline. In a retrospective cohort study, only paroxetine use during tamoxifen therapy was associated with an increased risk of death due to breast cancer.<sup>443</sup> **Paroxetine, fluoxetine, and sertraline are best avoided in women being treated with tamoxifen.**

# NEEDLE ASPIRATION

---

Needle aspiration of breast lumps can be part of the practice of everyone who cares for women.<sup>444</sup> The technique is easy. A small infiltrate of lidocaine is placed in the skin (many clinicians believe that local anesthesia is unnecessary). Holding the lesion between thumb and index fingers with one hand, the other hand passes a 22-gauge needle attached to a 3-finger control syringe into the lesion. Aspiration will reveal the presence of cystic fluid from a cyst. If the mass is solid, the needle should be passed at least 2–4 times (even more if nothing is being obtained) back and forth through the lesion with continuous suction on the syringe. Air is forcibly ejected through the needle onto a cytology slide for smearing and fixing. The usual Pap smear fixative can be used (**Figure 16.9**). The procedure is very cost-effective. When aspiration yields clear or cloudy, green-gray, or yellow fluid and the mass disappears, the procedure is both diagnostic and therapeutic. Fluid of any other nature requires cytologic assessment.<sup>445</sup> Failure to obtain material for cytologic evaluation or the persistence of a mass requires biopsy. The mass should not have returned at the follow-up examination 1 month after the aspiration. Locally, recurrent cysts should be surgically removed for histologic diagnosis.

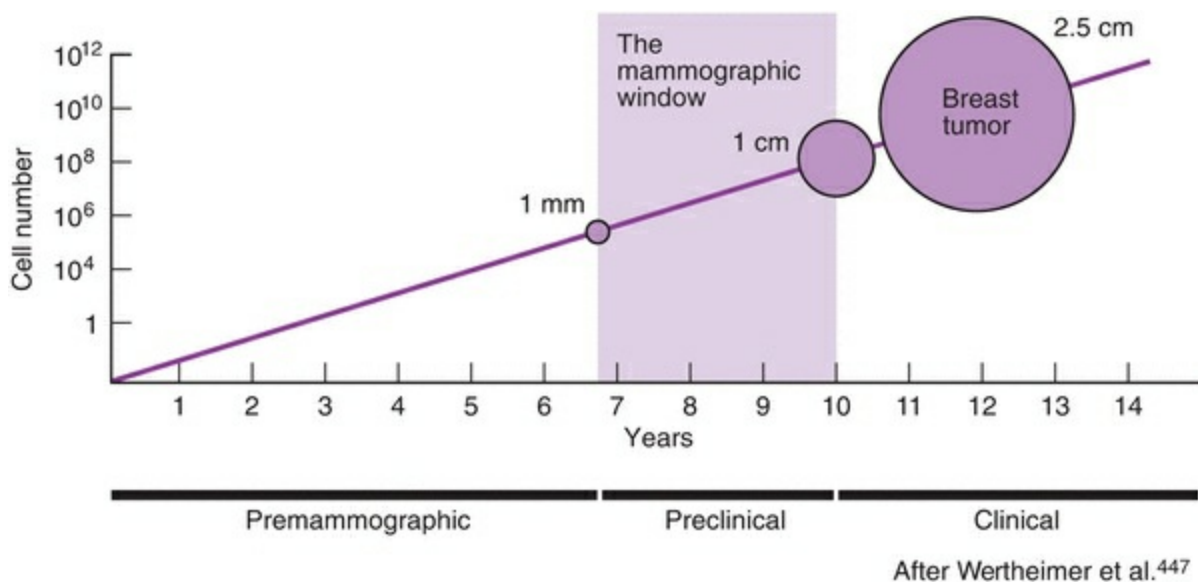


**FIGURE 16.9**



# SCREENING MAMMOGRAPHY

Mammography is a means of detecting a nonpalpable cancer. Technical advancements have significantly improved the mammographic image and reduced the radiation dose.<sup>446</sup> The doubling time of breast cancer is very variable, but in general, a tumor doubles in size every 100 days. Thus, it takes a single malignant cell approximately 10 years to grow to a clinically detectable 1-cm mass, but by this time, a tumor of 1 cm has already progressed through 30 of the 40 doublings in size, which is estimated to be associated with fatal disease.<sup>447</sup> Furthermore, the average size at which a tumor is detected has been (prior to mammography) 2.5 cm, a size that has a 50% incidence of lymph node involvement. Studies of breast self-examination have been disappointing in their failure to demonstrate an impact on breast cancer stage of disease and mortality.<sup>448</sup> To decrease the mortality from breast cancer, we must utilize a technique to find the tumors when they are smaller (**Figure 16.10**).



**FIGURE 16.10**

Mammography is the only method that detects clustered microcalcifications. These calcifications are less than 1 mm in diameter and are frequently associated with malignant lesions. More than five calcifications in a cluster are associated with cancer 25% of the time and require biopsy. Besides microcalcifications, the following mammographic findings usually require surgical evaluation: the appearance of a mass, calcifications associated with a mass, an area of distortion or asymmetrical density, and a stellate lesion. A pattern of dysplasia on the mammogram carries with it an increased risk (2.0–3.5 times normal) of breast cancer.

Mammography has a false-negative rate of 5–10%. This means that some masses are palpable but not visible. Mammography cannot and should not replace examination by patient and clinician. Breast examinations by clinicians do detect cancers that are missed by mammography.<sup>449</sup> Cancer commonly presents as a solitary, solid, painless (only 10% of cancers are painful), hard, unilateral, irregular nonmobile mass. A mass requires biopsy regardless of the mammographic picture.

# The Effectiveness of Mammography

Mammography reduces breast cancer mortality. The clinical trial results indicate increased survival with tumors detected by screening mammography, and in addition, early detection increases the options for treatment. About a 30% reduction in mortality can be expected with screening mammography of asymptomatic women over age 50.<sup>450,451</sup>

The U.S. Preventive Services Task Force recommends against routine screening mammography in women aged 40–49 and for extending the screening interval for women aged 50–74 to every 2 years.<sup>452</sup> The task force further recommends the discontinuation of breast self examinations. The recommendations of the U.S. Preventive Services Task Force represent the consensus of a panel of clinicians, academicians, and epidemiologists after a systematic review of the literature. The various task forces are often very conservative, refusing to make clinical judgments when evidence is deemed insufficient and focusing on a collective impact that includes not only clinical outcome but cost as well. We disagree with the task force recommendation on screening mammography for the following reasons.

About 20% of breast cancers occur in women 40–49, accounting for approximately 9% of all deaths due to breast cancer.<sup>128</sup> The American Breast Cancer Detection Demonstration Project demonstrated that screening was just as effective for women in their 40s as in women over their 50s.<sup>453</sup> This program that was organized by the American Cancer Society and the National Cancer Institute began operating in 1973 in 28 locations throughout the United States, enrolling more than 280,000 women. Despite the fact that this was not an organized research study with a control group, the massive database permits many valuable conclusions. From 1977 to 1982, similar high survival rates (87%) for women in their 40s compared with women in their 50s verify that screening was just as effective in the younger women. A 5-year survival rate for patients under 50 with breast cancers detected by examination was 77% compared to 95% in those patients with breast cancers detected by mammography.<sup>454</sup> In a randomized trial in Gothenburg, Sweden, women ages 39–49 undergoing mammographic screening every 18 months had a 45% reduction in breast cancer mortality in an early report and a 31% reduction after 13 years of follow-up.<sup>455,456</sup> Meta-analyses of randomized clinical trials concluded that in women aged 40–49 offered mammography screening, there was about a 20% reduction in breast cancer mortality.<sup>451,457,458</sup>

It takes longer for a significant difference in mortality to appear in 40–49-year-old women compared with women over age 50. There are two explanations. One is that tumors grow faster in younger women, and the other is the greater difficulty in achieving accurate mammography because of the denser, more glandular breasts in younger

women compared to the more fatty breasts in older women. Because the breast density changes gradually, rapid tumor growth must be the more critical factor.

Once detected by mammography, the stage of disease and survival expectations are the same in comparing women aged 40–49 with women over age 50.<sup>459</sup> However, cancers that are detected between screenings have lower survival rates (at all ages). Therefore, another reason that it has been difficult to demonstrate an impact of screening in the age group 40–49 is that because of less than annual screening, more of the cancers are detected late (between screenings). This in turn reflects the faster tumor growth in younger women.<sup>460</sup> Because the randomized clinical trials have screened younger women at 2-year or longer intervals, it is not surprising that screening has been less effective for these faster growing tumors. It is logical that women aged 40–49 should have annual screening mammography.<sup>461,462</sup> A randomized trial in the United Kingdom of annual mammographic screening beginning at age 40 indicated a 24% reduction in breast cancer mortality in the screened women.<sup>463</sup>

There are problems to be anticipated with extensive mammography screening. Small nonpalpable lesions have less than a 5% chance of being malignant, and overall only about 20–30% of biopsy specimens contain carcinoma. About 10% of mammograms require additional evaluation. That means there will be a large number of biopsies and mammograms performed (including the treatment of clinically irrelevant lesions), which involves costs to the health care system and cost to the individual in terms of stress and anxiety. Nevertheless, mammography is the most potent weapon we possess in the battle against breast cancer. Mammography not only lowers mortality, but it also decreases morbidity because less radical surgery is necessary for smaller lesions. Most importantly, the number of unnecessary surgical procedures can be minimized by combining physical examination and mammography with needle aspiration.<sup>464</sup> With the so-called triple approach (examination, mammography and possibly ultrasonography in young women, and needle aspiration), the detection of a malignancy with at least one of the three diagnostic tests is very reliable; open biopsy can be avoided.<sup>465,466,467</sup>

It is appropriate to be concerned over the increased cost of annual screening. However, analysis of the increased cost, taking into account the greater efficacy of capturing early tumors comparing annual to biannual screening, reveals that the overall benefit is worthwhile and compares favorably to the cost and benefits of Pap smear screening for cervical cancer.<sup>468,469</sup>

There is a special problem with elderly women. Old women are less likely to be screened with mammography, probably due to both patient misconceptions and erroneous clinician beliefs. Mammography reduces mortality and is cost-effective over age 65.<sup>470</sup> Decision analysis of available data predicts a major benefit for elderly

women, and a retrospective study indicated that screening mammography in women over age 74 is as beneficial as it is in younger women.<sup>471,472</sup> Older women need to be reminded that risk continues to increase with increasing age.

# Digital Mammography

Digital mammography replaces the screen and x-ray film with a detection system that converts x-ray photons to electric charge that is then converted to a digital image. This method performs better in women with dense breasts, accounting for the results in a randomized trial in which digital and film screening yielded equal results in women over age 50, but digital mammography was superior in younger women.<sup>473,474</sup> Digital mammography has some important advantages: easier access to images, more efficient storage of images, the use of computer-aided reading, and rapid data transfer between clinical sites. Studies have also indicated lower recall rates because of better image quality and fewer artifacts.

# Adding Ultrasound to Mammography

A prospective, multicenter, randomized trial was designed to validate the performance of screening ultrasound in conjunction with mammography in women with dense breasts and at high risk for breast cancer.<sup>475</sup> The study is known as ACRIN, the American College of Radiology Imaging Network, 6666 trial. Each patient underwent mammography and ultrasound in a randomized sequence. Forty cases of cancer were diagnosed, 12 on ultrasound alone, 12 on mammography alone, 8 suspicious with both techniques, and 8 with negative exams. Adding ultrasound yielded an additional 4.2 cancers per 1,000 high-risk women. The false-positive rate for mammography alone was 4.4%, for ultrasound alone 8.1%, and for combined mammography plus ultrasound 10.4%. Thus, adding ultrasound to mammography screening in high-risk women with dense breasts improved the sensitivity of screening but increased the rate of false-positive examinations. Breast cancer mortality was not an endpoint in this trial, but the fact that the cancers detected by ultrasound are usually asymptomatic, node-negative, and not detected by mammography should yield a reduction in mortality.

Ultrasound screening can detect cancers not seen on mammography, and its performance is not affected by dense breast tissue. Adding ultrasound to a screening program seems straightforward, even though its impact on mortality reduction has not been measured in a large trial. In the single-center studies of screening ultrasound that have been published, cancers were found only by ultrasound, and most were small, early-stage tumors. An Italian multicenter study reported that 29 cancers were found by ultrasound in 6,449 women with dense breasts and negative mammograms.<sup>476</sup> Nevertheless, a majority of facilities do not offer screening ultrasound because of a lack of qualified personnel and standardized protocols.

The problem with all screening methods is a substantial rate of false positives. In the American study, 91.4% of suspicious ultrasound findings were benign.<sup>475</sup> The positive predictive value for ultrasound was only 8.6%, but the value for mammography was only 14.7%. Remember that ultrasound tends to find earlier tumors. The crucial question is how many false positives are worth the gain in additional cancer diagnoses. In the American study, the gain was an additional 29% (the number of cancers detected only by ultrasound). In women with elevated risks or dense breasts, this seems worthwhile. **Women at high risk probably have a greater fear of diagnosing breast cancer late than of a false positive.**

# Adding MRI to Mammography

MRI is the most sensitive technique, but it is very expensive, requires the intravenous injection of contrast, and isn't always tolerated by patients. Ultrasound has the advantage of being less expensive, easily tolerated, and widely available. Thus, the combination of ultrasound and mammography seems best for women of intermediate risk. Ultrasound has a disadvantage of not detecting ductal carcinoma in situ, which is detected by mammography and MRI. **Combining MRI with mammography yields a very high sensitivity, and this is now recommended for women at very high risk for breast cancer, especially younger women.**<sup>477,478,479</sup>

MRI is more sensitive in diagnosing breast ductal carcinoma in situ.<sup>480</sup> Ductal carcinoma in situ is a precursor of invasive breast cancer, with progression occurring more often and more rapidly with higher-grade in situ lesions, and the subsequent invasive disease is of a higher grade with a poorer prognosis. Diagnosis of higher-grade ductal carcinoma in situ is, therefore, highly desirable. Mammography has led to an increase in the diagnosis of ductal carcinoma in situ from 2% of breast cancers in 1980 to 20% today. Earlier studies concluded that MRI was no better and even worse than mammography in diagnosing ductal carcinoma in situ. However, it has been learned that diagnostic criteria differ with the two techniques, incorporating not only morphology but enhancement kinetics with contrast during MRI. MRI detects lesions without microcalcifications (a different group of tumors), whereas mammography detects cases of ductal carcinoma in situ that have microcalcifications caused by necrosis.

Both film-screen mammography and digital mammography have limited sensitivity for diagnosing ductal carcinoma in situ (determined by the size of microcalcifications). An important message is that MRI is better for the detection of the higher-grade ductal carcinoma in situ associated with worse prognosis. The reason for this is the contribution of contrast enhancement. Tissues with higher-grade lesions will have greater capillary permeability and an increase in microvasculature, accounting for more contrast enhancement.

The availability of MRI in general population screening is currently limited by an insufficient number of radiologists with the required level of expertise, but there are an increasing number of specialty centers with the expertise and technology to perform accurate MRIs. The full use of MRI to detect breast cancer at its earliest stage awaits the results of a large multicenter trial that is obviously now indicated.

The final protocol for the best screening use of the three modalities, mammography, ultrasound, and MRI, will also require consideration of cost. The total cost is a complex summary of the technology, the time consumed, the increase in patient anxiety and



discomfort, and the expense of additional testing because of false positives. Nevertheless, the evidence now seems sufficient to individualize decision-making and to recommend more than the single technique of mammography for high-risk patients (defined as a combination of factors that produces a threefold increase in risk), especially in women with dense breasts. Thus far, over 90% of cancers detected only on ultrasound were in women with dense breasts.

Every woman should be regarded as at risk. Health care professionals who interact with women have the opportunity to initiate an aggressive program of preventive health care. The major deterrent to patient use of screening is the absence of a strong clinician recommendation. We urge you to follow these guidelines:

# SCREENING FOR BREAST CANCER

---

- **Women ages 25–39 should be offered a clinical breast examination every 1–3 years, and women ages 40 and over should be offered clinical breast examination annually.**
- **Women with a first-degree relative with premenopausal breast cancer should begin annual mammography 5 years before the age of the relative when diagnosed.**
- **Annual mammography should be performed in all women over age 39.**
- **Digital mammography is preferred for women with dense breasts.**
- **It is advisable to add ultrasonography to mammography for hormone users who develop dense breasts and density that persists despite a short period without hormone therapy.**
- **MRI should be added to mammography for women at very high risk for breast cancer (defined as a combination of factors that produces a threefold increase in risk), especially younger women. For an individual identified to be at high risk, especially women with inherited mutations, clinical breast examination is recommended every 6 months and annual mammography and MRI beginning at age 25. Clinical evaluation every 6 months is appropriate because the BRCA1-related tumors have been demonstrated to be faster growing tumors. Support should be provided for those women who choose prophylactic mastectomy. Risk-reducing salpingo-oophorectomy is recommended at age 35 or when childbearing is complete for patients carrying BRCA1 mutations, and by age 40 in BRCA2 carriers.**

# REFERENCES

1. **Jerome-Majewska LA, Jenkins GP, Ernstoff E, Zindy F, Sherr CJ, Papaioannou VE**, Tbx3, the ulnar-mammary syndrome gene, and Tbx2 interact in mammary gland development through p19Arf/p53-independent pathway, *Dev Dyn* 234:922, 2005.
2. **Bamshad M, Lin RC, Law DJ, Watkins WC, Krakowiak PA, Moore ME**, et al., Mutations in human TBX3 alter limb, apocrine and genital development in ulnar-mammary syndrome, *Nat Genet* 16:311, 1997.
3. **Cowin P, Wysolmerski J**, Molecular mechanisms guiding embryonic mammary gland development, *Cold Spring Harb Perspect Biol* 2(6):a003251, 2010.
4. **Hens JR, Dann P, Zhang JP, Harris S, Robinson GW, Wysolmerski J**, BMP4 and PTHrP interact to stimulate ductal outgrowth during embryonic mammary development and to inhibit hair follicle induction, *Development* 134:1221, 2007.
5. **Trott JF, Vonderhaar BK, Hovey RC**, Historical perspectives of prolactin and growth hormone as mammogenesis, lactogenesis, and galactagogues—agog for the future! *J Mammary Gland Biol Neoplasia* 13:3, 2008.
6. **Enmark E, Pelto-Huikko M, Grandien K, Lagercrantz S, Lagercrantz J, Fried G, Nordenskjöld M, Gustafsson J-Å**, Human estrogen receptor  $\beta$ -gene structure, chromosomal localization, and expression pattern, *J Clin Endocrinol Metab* 82:4258, 1997.
7. **Shyamala G**, Roles of estrogen and progesterone in normal mammary gland development. Insights from progesterone receptor null mutant mice and in situ localization of receptor, *Trends Endocrinol Metab* 8:34, 1997.
8. **Kleinberg DL, Niemann W, Flamm E, Cooper P, Babitsky G**, Primate mammary development, *J Clin Invest* 75:1943, 1985.
9. **Kleinberg DL, Wood TL, Furth PA, Lee AV**, Growth hormone and insulin-like growth factor-I in the transition from normal mammary development to preneoplastic mammary lesions, *Endocr Rev* 30:51, 2009.
10. **Feng Y, Manka D, Wagner KU, Khan SA**, Estrogen receptor-alpha expression in the mammary epithelium is required for ductal and alveolar morphogenesis in mice, *Proc Natl Acad Sci* 104:14718, 2007.
11. **Ruan W, Monaco ME, Kleinberg DL**, Progesterone stimulates mammary gland ductal morphogenesis by synergizing with and enhancing insulin-like growth factor-I action, *Endocrinology* 146:117, 2005.
12. **Mulac-Jericevic B, Lydon JP, DeMayo FJ, Conneely OM**, Defective mammary gland morphogenesis in mice lacking the progesterone receptor B isoform, *Proc Natl Acad Sci U S A* 100:9744, 2003.
13. **Christiansen E, Veldhuis JD, Rogol AD, Stumpf P, Evans WS**, Modulating actions of estradiol on gonadotropin-releasing hormone-stimulated prolactin secretion in postmenopausal individuals, *Am J Obstet Gynecol* 157:320, 1987.
14. **Ferguson DP, Anderson TJ**, Morphological evaluation of cell turnover in relation to menstrual cycle in the “resting” human breast, *Br J Cancer* 44:177, 1988.
15. **Longacre TA, Bartow SA**, A correlative morphologic study of human breast and endometrium in the menstrual cycle, *Am J Surg Pathol* 10:382, 1986.
16. **Going JJ, Anderson TJ, Battersby S, MacIntyre CC**, Proliferative and secretory activity in human breast during natural and artificial menstrual cycles, *Am J Pathol* 130:193, 1988.
17. **Söderqvist G, Isaksson E, von Schoultz B, Carlström K, Tani E, Skoog L**, Proliferation of breast epithelial cells in healthy women during the menstrual cycle, *Am J Obstet Gynecol* 176:123, 1997.
18. **Potten CS, Watson RJ, Williams GT, Tickle S, Roberts SA, Harris M, Howell A**, The effect of age and menstrual cycle upon proliferative activity of the normal human breast, *Br J Cancer* 58:163, 1988.
19. **Vogel PM, Georgiade NG, Fetter BF, Vogel FS, McCarty KS**, The correlation of histologic changes in the human breast with the menstrual cycle, *Am J Pathol* 104:23, 1981.
20. **Chang K-J, Lee TTY, Linarez-Cruz G, Fournier S, de Lignières B**, Influences of percutaneous administration of estradiol and progesterone on human breast epithelial cell cycle in vivo, *Fertil Steril* 63:785, 1995.
21. **Laidlaw IJ, Clarke RB, Howell A, Owen AW, Potten CS, Anderson E**, The proliferation of normal human

- breast tissue implanted into athymic nude mice is stimulated by estrogen but not progesterone, *Endocrinology* 136:164, 1996.
22. **Foidart J-M, Colin C, Denoo X, Desreux J, Béliard A, Fournier S, de Ligni eres B**, Estradiol and progesterone regulate the proliferation of human breast epithelial cells, *Fertil Steril* 69:963, 1998.
  23. **Jernstrom H, Olsson H**, Breast size in relation to endogenous hormone levels, body constitution, and oral contraceptive use in healthy nulligravid women aged 19–25 years, *Am J Epidemiol* 145:571, 1997.
  24. **Urbani CE, Betti R**, Familial aberrant mammary tissue: a clinicoepidemiological survey of 18 cases, *Dermatology* 190:207, 1995.
  25. **Urbani CE, Betti R**, Accessory mammary tissue associated with congenital and hereditary nephrourethral malformations, *Int J Dermatol* 35:349, 1996.
  26. **Armoni M, Filk D, Schlesinger M, Pollak S, Metzker A**, Accessory nipples: any relationship to urinary tract malformation?, *Pediatr Dermatol* 9:239, 1992.
  27. **Joart G, Seres E**, Supernumerary nipples and renal anomalies, *Int Urol Nephrol* 26:141, 1994.
  28. **Grotto I, Browner-Elhanan K, Mimouni D, Varsano I, Cohen HA, Mimouni M**, Occurrence of supernumerary nipples in children with kidney and urinary tract malformations, *Pediatr Dermatol* 18:291, 2001.
  29. **Ferraro P, Giorgio V, Vitelli O, Gatto A, Romanov V, Bufalo FD, Nicoletti A**, Polythelia: still a marker of urinary tract anomalies in children?, *Scand J Urol Nephrol* 43:47, 2009.
  30. **Loukas M, Clarke P, Tubbs R**, Accessory breasts: a historical and current perspective, *Am Surg* 73:525, 2007.
  31. **Lesavoy MA, Gomez-Garcia A, Nejdil R, Yospur G, Syiau TJ, Chang P**, Axillary breast tissue: clinical presentation and surgical treatment, *Ann Plast Surg* 35: 356, 1995.
  32. **Bole-Feysoot C, Goffin V, Edery M, Binart N, Kelly PA**, Prolactin (PRL) and its receptor: actions, signal transduction pathways and phenotypes observed in PRL receptor knockout mice, *Endocr Rev* 19:225, 1998.
  33. **Hattori N, Ishihara T, Ikekubo K, Moridera K, Hino M, Kurahachi H**, Autoantibody to human prolactin in patients with idiopathic hyperprolactinemia, *J Clin Endocrinol Metab* 75:1226, 1992.
  34. **Hattori N, Inagaki C**, Anti-prolactin (PRL) autoantibodies cause asymptomatic hyperprolactinemia: bioassay and clearance studies of PRL-immunoglobulin G complex, *J Clin Endocrinol Metab* 82:3107, 1997.
  35. **Smith TP, Suliman AM, Fahie-Wilson MN, McKenna TJ**, Gross variability in the detection of prolactin in sera containing big big prolactin (macroprolactin) by commercial immunoassays, *J Clin Endocrinol Metab* 87:5410, 2002.
  36. **Brue T, Caruso E, Morange I, Hoffmann T, Evrin M, Gunz G, Benkirane M, Jaquet P**, Immunoradiometric analysis of circulating human glycosylated and nonglycosylated prolactin forms: spontaneous and stimulated secretions, *J Clin Endocrinol Metab* 75:1338, 1992.
  37. **Boockfor FR, Hoeffler JP, Frawley LS**, Estradiol induces a shift in cultured cells that release prolactin or growth hormone, *Am J Physiol* 250:E103, 1986.
  38. **Maurer RA**, Estradiol regulates the transcription of the prolactin gene, *J Biol Chem* 257:2133, 1982.
  39. **Cramer OM, Parker CR, Porter JC**, Estrogen inhibition of dopamine release into hypophyseal portal blood, *Endocrinology* 104:419, 1979.
  40. **Zinger M, McFarland M, Ben-Jonathan N**, Prolactin expression and secretion by human breast glandular and adipose tissue explants, *J Clin Endocrinol Metab* 88:689, 2003.
  41. **Snyder JM, Dekowski SA**, The role of prolactin in fetal lung maturation, *Seminars Reprod Endocrinol* 10:287, 1992.
  42. **McCoshen JA, Bose R, Embree JE**, Uterine prolactin and labor: modulation by human chorionic gonadotropin affects prostaglandin (PG) E2 and PGF2a production, *Seminars Reprod Endocrinol* 10:294, 1992.
  43. **Ben-Jonathan N, Hnasko R**, Dopamine as a prolactin (PRL) inhibitor, *Endocr Rev* 22:724, 2001.
  44. **Grattan DR**, 60 years of neuroendocrinology: the hypothalamo-prolactin axis, *J Endocrinol* 226:T101, 2015.
  45. **Maaskant RA, Bogic LV, Gilger S, Kelly PA, Bryant-Greenwood GD**, The human prolactin receptor in the fetal membranes, decidua, and placenta, *J Clin Endocrinol Metab* 81:396, 1996.
  46. **Kelly PA, Kijane J, Postel-Vinay M-C, Edery M**, The prolactin/growth hormone receptor family, *Endocr Rev* 12:235, 1991.

47. **Daly DC, Kuslis S, Riddick DH**, Evidence of short-loop inhibition of decidual prolactin synthesis by decidual proteins, Part I, *Am J Obstet Gynecol* 155:358, 1986.
48. **Raabe MA, McCoshen JA**, Epithelial regulation of prolactin effect on amnionic permeability, *Am J Obstet Gynecol* 154:130, 1986.
49. **Luciano AA, Varner MW**, Decidual, amniotic fluid, maternal, and fetal prolactin in normal and abnormal pregnancies, *Obstet Gynecol* 63:384, 1984.
50. **Golander A, Kopel R, Lasebik N, Frenkel Y, Spirer Z**, Decreased prolactin secretion by decidual tissue of pre-eclampsia in vitro, *Acta Endocrinol* 108:111, 1985.
51. **Healy DL, Herington AC, O'Herlihy C**, Chronic polyhydramnios is a syndrome with a lactogen receptor defect in the chorion laeva, *Br J Obstet Gynaecol* 92:461, 1985.
52. **Tyson JE, Hwang P, Guyda H, Friesen HG**, Studies of prolactin secretion in human pregnancy, *Am J Obstet Gynecol* 113:14, 1972.
53. **Kletzky OA, Marrs RP, Howard WF, McCormick W, Mishell DR Jr**, Prolactin synthesis and release during pregnancy and puerperium, *Am J Obstet Gynecol* 136:545, 1980.
54. **Tyson JE, Friesen HG**, Factors influencing the secretion of human prolactin and growth hormone in menstrual and gestational women, *Am J Obstet Gynecol* 116:377, 1973.
55. **Barberia JM, Abu-Fadil S, Kletzky OA, Nakamura RM, Mishell DR Jr**, Serum prolactin patterns in early human gestation, *Am J Obstet Gynecol* 121:1107, 1975.
56. **Ehara Y, Siler TM, Yen SSC**, Effects of large doses of estrogen on prolactin and growth hormone release, *Am J Obstet Gynecol* 125:455, 1976.
57. **Murphy LJ, Murphy LC, Stead B, Sutherland RL, Lazarus L**, Modulation of lactogenic receptors by progestins in cultured human breast cancer cells, *J Clin Endocrinol Metab* 62:280, 1986.
58. **Simon WE, Pahnke VG, Holzel F**, In vitro modulation of prolactin binding to human mammary carcinoma cells by steroid hormones and prolactin, *J Clin Endocrinol Metab* 60:1243, 1985.
59. **Lee CS, Oka T**, Progesterone regulation of pregnancy-specific transcription repressor to b-casein gene promoter in mouse mammary gland, *Endocrinology* 131:2257, 1992.
60. **Zuppa AA, Sindico P, Orchi C, Carducci C, Cardiello V, Romagnoli C, Catenazzi P**, Safety and efficacy of galactogogues: substances that induce, maintain, and increase breast milk production, *J Pharm Pharm Sci* 13:162, 2010.
61. **Battin DA, Marrs RP, Fleiss PM, Mishell DR Jr**, Effect of suckling on serum prolactin, luteinizing hormone, follicle-stimulating hormone, and estradiol during prolonged lactation, *Obstet Gynecol* 65:785, 1985.
62. **Stern JM, Konner M, Herman TN, Reichlin S**, Nursing behaviour, prolactin, and postpartum amenorrhoea during prolonged lactation in American and !Kung mothers, *Clin Endocrinol* 25:247, 1986.
63. **Tay CCK, Glasier AF, McNeilly AS**, Twenty-four hour patterns of prolactin secretion during lactation and the relationship to suckling and the resumption of fertility in breast-feeding women, *Hum Reprod* 11:950, 1996.
64. **Dawood MY, Khan-Dawood FS, Wahl RS, Fuchs F**, Oxytocin release and plasma anterior pituitary and gonadal hormones in women during lactation, *J Clin Endocrinol Metab* 52:678, 1981.
65. **McNeilly AS, Robinson KA, Houston MJ, Howe PW**, Release of oxytocin and prolactin in response to suckling, *Br Med J* 286:257, 1983.
66. **Kumar R, Cohen WR, Epstein FH**, Vitamin D and calcium hormones in pregnancy, *N Engl J Med* 302:1143, 1980.
67. **Kovacs CS, Kronenberg HM**, Maternal-fetal calcium and bone metabolism during pregnancy, puerperium and lactation, *Endocr Rev* 18:832, 1997.
68. **Sowers M, Corton G, Shapiro B, Jannausch ML, Crutchfield M, Smith ML, Randolph JF, Hollis B**, Changes in bone density with lactation, *JAMA* 269:3130, 1993.
69. **Kalkwarf HJ, Specker BL**, Bone mineral loss during lactation and recovery after weaning, *Obstet Gynecol* 86:26, 1995.
70. **Kovacs CS**, Calcium and bone metabolism in pregnancy and lactation, *J Clin Endocrinol Metab* 86:2344, 2001.
71. **Kalkwarf HJ, Specker BL, Bianchi DC, Ranz J, Ho M**, The effect of calcium supplementation on bone density during lactation and after weaning, *N Engl J Med* 337:523, 1997.

72. **Kovacs CS**, Vitamin D in pregnancy and lactation: maternal, fetal, and neonatal outcomes from human and animal studies, *Am J Clin Nutr* 88(Suppl):520S, 2008.
73. **Laskey MA, Prentice A, Hanratty LA, Jarjou LM, Dibba B, Beavan SR, Cole TJ**, Bone changes after 3 mo of lactation: influence of calcium intake, breast-milk output, and vitamin D-receptor genotype, *Am J Clin Nutr* 67:685, 1998.
74. **Ritchie LD, Fung EB, Halloran BP, Turnlund JR, Van Loan MD, Cann CE, King JC**, A longitudinal study of calcium homeostasis during human pregnancy and lactation and after resumption of menses, *Am J Clin Nutr* 67:693, 1998.
75. **Polatti F, Capuzzo E, Viazzo F, Colleoni R, Klersy C**, Bone mineral changes during and after lactation, *Obstet Gynecol* 94:52, 1999.
76. **Kojima N, Douchi T, Kosha S, Nagata Y**, Cross-sectional study of the effects of parturition and lactation on bone mineral density later in life, *Maturitas* 41:203, 2002.
77. **Karlsson C, Obrant KJ, Karlsson M**, Pregnancy and lactation confer reversible bone loss in humans, *Osteoporosis Int* 12:828, 2001.
78. **Ofluoglu O, Ofluoglu D**, A case report: pregnancy-induced severe osteoporosis with eight vertebral fractures, *Rheumatol Int* 29:197, 2008.
79. **Stumpf UC, Kurth AA, Windolf J, Fassbender WJ**, Pregnancy-associated osteoporosis: an underestimated and underdiagnosed severe disease. A review of two cases in short- and long-term follow-up, *Adv Med Sci* 52:94, 2007.
80. **Hellmeyer L, Kuhnert M, Ziller V, Hadji P**, The use of i.v. bisphosphonate in pregnancy-associated osteoporosis—case study, *Exp Clin Endocrinol Diabetes* 115:139, 2007.
81. **Mast EE, Margolis HS, Fiore AE, Brink EW, Goldstein ST, Wang SA, et al.; Advisory Committee on Immunization Practices (ACIP)**, A comprehensive immunization strategy to eliminate transmission of hepatitis B virus infection in the United States: recommendations of the Advisory Committee on Immunization Practices (ACIP) part 1: immunization of infants, children, and adolescents. *MMWR Recomm Rep* 54(Rr-16):1, 2005.
82. **Dewey KG, Lovelady CA, Nommsen-Rivers LA, McCrory MA, Lönnerdal B**, A randomized study of the effects of aerobic exercise by lactating women on breast-milk volume and composition, *N Engl J Med* 330:449, 1994.
83. **McClellan HL, Miller SJ, Hartmann PE**, Evolution of lactation: nutrition v. protection with special reference to five mammalian species, *Nutr Res Rev* 21:97, 2008.
84. **Geddes DT, Kent JC, Mitoulas LR, Hartmann PE**, Tongue movement and intra-oral vacuum in breastfeeding infants, *Early Hum Dev* 84:471, 2008.
85. **Nishimori K, Young LJ, Guo Q, Wang Z, Insel TR, Matzuk MM**, Oxytocin is required for nursing but is not essential for parturition or reproductive behavior, *Proc Natl Acad Sci U S A* 93:11699, 1996.
86. **Auerbach KG, Avery JL**, Induced lactation, *Am J Dis Child* 135:340, 1981.
87. **Betzold CM**, Galactagogues, *J Midwifery Womens Health* 49:151, 2004.
88. **Wasalathanthri S, Tennekoon KH**, Lactational amenorrhea/anovulation and some of their determinants: a comparison of well-nourished and undernourished women, *Fertil Steril* 76:317, 2001.
89. **Campbell OM, Gray RH**, Characteristics and determinants of postpartum ovarian function in women in the United States, *Am J Obstet Gynecol* 169:55, 1993.
90. **Labbok MH, Hight-Laukaran V, Peterson AE, Fletcher V, von Hertzen H, Van Look PFA**, Multicenter study of the lactational amenorrhea method (LAM): I. Efficacy, duration, and implications for clinical application, *Contraception* 55:327, 1997.
91. **Visness CM, Kennedy KI, Gross BA, Parenteau-Carreau S, Flynn AM, Brown JB**, Fertility of fully breast-feeding women in the early postpartum period, *Obstet Gynecol* 89:164, 1997.
92. **Diaz S, Aravena R, Cardenas H, Casado ME, Miranda P, Schiappacasse V, Croxatto HB**, Contraceptive efficacy of lactational amenorrhea in urban Chilean women, *Contraception* 43:335, 1991.
93. **Kremer JAM, Thomas CMG, Rolland R, van der Heijden PF, Thomas CM, Lancranjan I**, Return of gonadotropic function in postpartum women during bromocriptine treatment, *Fertil Steril* 51:622, 1989.

94. **Haartsen JE, Heineman MJ, Elings M, Evers JLH, Lancranjan I**, Resumption of pituitary and ovarian activity post-partum: endocrine and ultrasonic observations in bromocriptine-treated women, *Hum Reprod* 7:746, 1992.
95. **Tyson JE, Carter JN, Andreassen B, Huth J, Smith B**, Nursing-mediated prolactin and luteinizing hormone secretion during puerperal lactation, *Fertil Steril* 30:154, 1978.
96. **Veldhuis JD**, Interactions among endocrine control systems in the regulation of ovarian function, *Clin Biochem* 14:252, 1981.
97. **Sauder SE, Frager M, Case GD, Kelch RP, Marshall JC**, Abnormal patterns of pulsatile luteinizing hormone secretion in women with hyperprolactinemia and amenorrhea: responses to bromocriptine, *J Clin Endocrinol Metab* 59:941, 1984.
98. **Tay CCK, Glasier A, McNeilly AS**, Twenty-four hour secretory profiles of gonadotropins and prolactin in breastfeeding women, *Hum Reprod* 7:951, 1992.
99. **Ishizuka B, Quigley ME, Yen SSC**, Postpartum hypogonadotrophinism: evidence for increased opioid inhibition, *Clin Endocrinol* 20:573, 1984.
100. **Petraglia F, De Leo V, Nappi C, Facchinetti F, Montemagno U, Brambilla F, Genazzani AR**, Differences in the opioid control of luteinizing hormone secretion between pathological and iatrogenic hyperprolactinemic states, *J Clin Endocrinol Metab* 64:508, 1987.
101. **Tay CCK, Glasier AF, McNeilly AS**, Effect of antagonists of dopamine and opiates on the basal and GnRH-induced secretion of luteinizing hormone, follicle stimulating hormone and prolactin during lactational amenorrhea in breastfeeding women, *Hum Reprod* 8:532, 1993.
102. **Zinaman MJ, Cartledge T, Tomai T, Tippett P, Merriam GR**, Pulsatile GnRH stimulates normal cyclic ovarian function in amenorrheic lactating postpartum women, *J Clin Endocrinol Metab* 80:2088, 1995.
103. **Sherman L, Fisher A, Klass E, Markowitz S**, Pharmacologic causes of hyperprolactinemia, *Seminars Reprod Endocrinol* 2:31, 1984.
104. **Davis JRE, Selby C, Jeffcoate C**, Oral contraceptive agents do not affect serum prolactin in normal women, *Clin Endocrinol* 20:427, 1984.
105. **Hwang PLH, Ng CSA, Cheong ST**, Effect of oral contraceptives on serum prolactin: a longitudinal study in 126 normal premenopausal women, *Clin Endocrinol* 24:127, 1986.
106. **Modest GA, Fangman JJ**, Nipple piercing and hyperprolactinemia, *N Engl J Med* 347:1626, 2002.
107. **Tuzcu A, Bahceci M, Dursun M, Turgut C, Bahceci S**, Insulin sensitivity and hyperprolactinemia, *J Endocrinol Invest* 26:341, 2003.
108. **Bahceci M, Tuzcu A, Bahceci S, Tuzcu S**, Is hyperprolactinemia associated with insulin resistance in non-obese patients with polycystic ovary syndrome? *J Endocrinol Invest* 26:655, 2003.
109. **Yavuz D, Deyneli O, Akpinar I, Yildiz E, Gozu H, Sezgin O, Haklar G, Akalin S**, Endothelial function, insulin sensitivity and inflammatory markers in hyperprolactinemic pre-menopausal women, *Eur J Endocrinol* 149:187, 2003.
110. **Kim SY, Sung YA, Ko KS, Cho BY, Lee HK, Koh CS, Min HK**, Direct relationship between elevated free testosterone and insulin resistance in hyperprolactinemic women, *Korean J Intern Med* 8:8, 1993.
111. **Seki K, Nagata I**, Levels of glucose and insulin during twenty-four hours in hyperprolactinemic women with pituitary microadenoma, *Gynecol Obstet Invest* 31:222, 1991.
112. **Serri O, Beauregard H, Rasio E, Hardy J**, Decreased sensitivity to insulin in women with microprolactinomas, *Fertil Steril* 45:572, 1986.
113. **Gustafson AB, Banasiak MF, Kalkhoff RK, Hagen TC, Kim HJ**, Correlation of hyperprolactinemia with altered plasma insulin and glucagon: similarity to effects of late human pregnancy, *J Clin Endocrinol Metab* 51:242, 1980.
114. **Johnston DG, Alberti KG, Nattrass M, Burrin JM, Blesa-Malpica G, Hall K, Hall R**, Hyperinsulinaemia in hyperprolactinemic women, *Clin Endocrinol* 13:361, 1980.
115. **Ader DN, Browne MW**, Prevalence and impact of cyclic mastalgia in a United States clinic-based sample, *Am J Obstet Gynecol* 177:126, 1997.
116. **Pye JK, Mansel RE, Hughes LE**, Clinical experience of drug treatments for mastalgia, *Lancet* ii:373, 1985.

117. **Kontostolis E, Stefanidis K, Navrozoglou I, Lolis D**, Comparison of tamoxifen with danazol for treatment of cyclical mastalgia, *Gynecol Endocrinol* 11:393, 1997.
118. **Parsay S, Olfati F, Nahidi S**, Therapeutic effects of vitamin E on cyclic mastalgia, *Breast J*, 15:510, 2009.
119. **Fentiman IS, Brame K, Caleffi M, Chaudary MA, Hayward JL**, Double-blind controlled trial of tamoxifen therapy for mastalgia, *Lancet* i:287, 1986.
120. **Ernster VL, Mason L, Goodson III WH, Sickles EA, Sacks ST, Selvin S, Dupuy ME, Hawkinson J, Hunt TK**, Effects of caffeine-free diet on benign breast disease: a randomized trial, *Surgery* 91:263, 1982.
121. **Schairer C, Brinton LA, Hoover RN**, Methylxanthines and benign breast disease, *Am J Epidemiol* 124:603, 1986.
122. **Allen S, Froberg D**, The effect of decreased caffeine consumption on benign proliferative breast disease: a randomized trial, *Surgery* 101:720, 1987.
123. **Lubin F, Ron E**, Consumption of methylxanthine-containing beverages and the risk of breast cancer, *Cancer Lett* 53:81, 1990.
124. **Zheng W, Doyle TJ, Kushi LH, Sellers TA, Hong CP, Folsom AR**, Tea consumption and cancer incidence in a prospective cohort study of postmenopausal women, *Am J Epidemiol* 144:175, 1996.
125. **Michels KB, Holmberg L, Bergkvist L, Wolk A**, Coffee, tea, and caffeine consumption and breast cancer incidence in a cohort of Swedish women, *Ann Epidemiol* 12:21, 2002.
126. **Ishitani K, Lin J, Manson JE, Buring JE, Zhang SM**, Caffeine consumption and the risk of breast cancer in a large prospective cohort of women, *Arch Intern Med* 168:2022, 2008.
127. **Ganmaa D, Willett WC, Li TY, Feskanich D, Van Dam RM, Lopez-Garcia E, Hunter DJ, Holmes MD**, Coffee, tea, caffeine and risk of breast cancer: a 22-year follow-up, *Int J Cancer* 122:2071, 2008.
128. **American Cancer Society**, Cancer Facts & Figures 2017–2018, <https://www.cancer.org/content/dam/cancer-org/research/cancer-facts-and-statistics/breast-cancer-facts-and-figures/breast-cancer-facts-and-figures-2017-2018.pdf>, 2017.
129. **Surveillance Epidemiology and End Results**, Cancer Stat Facts: Female Breast Cancer, <http://seer.cancer.gov/statfacts/html/breast.html>, April 16, 2018.
130. **Centers for Disease Controls and Prevention**, Unites States Cancer Statistics, <https://gis.cdc.gov/Cancer/USCS/DataViz.html>, November 2017.
131. **American Cancer Society**, Cancer Reference Information, [http://www.cancer.org/docroot/CRI/content/CRI\\_2\\_4\\_2X\\_What\\_are\\_the\\_risk\\_factors\\_for\\_breast\\_cancer\\_5.a](http://www.cancer.org/docroot/CRI/content/CRI_2_4_2X_What_are_the_risk_factors_for_breast_cancer_5.a) 2010.
132. **Ursin G, Bernstein L, Lord SJ, Karim R, Deapen D, Press MF, Daling JR, Norman SA, Liff JM, Marchbanks PA, Folger SG, Simon MS, Strom BL, Burkman RT, Weiss LK, Spirtas R**, Reproductive factors and subtypes of breast cancer defined by hormone receptor and histology, *Br J Cancer* 93:364, 2005.
133. **Lord SJ, Bernstein L, Johnson KA, Malone KE, McDonald JA, Marchbanks PA, Simon MS, Strom BL, Press MF, Folger SG, Burkman RT, Deapen D, Spirtas R, Ursin G**, Breast cancer risk and hormone receptor status in older women by parity, age of first birth, and breastfeeding: a case-control study, *Cancer Epidemiol Biomarkers Prev* 17:1723, 2008.
134. **Ewertz M, Duffy SW, Adami H-O, Kvale G, Lund E, Meirik O, Mellempgaard A, Soini I, Tulinius H**, Age at first birth, parity and risk of breast cancer: a meta-analysis of 8 studies from the Nordic countries, *Int J Cancer* 46:597, 1990.
135. **Kalache A, Maguire A, Thompson SG**, Age at last full-term pregnancy and risk of breast cancer, *Lancet* 341:33, 1993.
136. **Pathak DR, Speizer FE, Willett WC, Rosner B, Lipnick RJ**, Parity and breast cancer risk: possible effect on age at diagnosis, *Int J Cancer* 37:21, 1986.
137. **Talamini R, Franceschi S, La Vecchia C, Negri E, Borsa L, Montella M, Falcini F, Conti E, Rossi C**, The role of reproductive and menstrual factors in cancer of the breast before and after menopause, *Eur J Cancer* 32A:303, 1996.
138. **Cummings P, Stanford JL, Daling JR, Weiss NS, McKnight B**, Risk of breast cancer in relation to the interval since last full term pregnancy, *Br Med J* 308:1672, 1994.



139. **Lambe M, Hsieh C, Trichopoulos D, Ekblom A, Pavia M, Adami H-O**, Transient increase in the risk of breast cancer after giving birth, *N Engl J Med* 331:5, 1994.
140. **Guinee VF, Olsson H, Moller T, Hess KR, Taylor SH, Fahey T, Gladikov JV, van den Blink JW, Bonichon F, Dische S, et al.**, Effect of pregnancy on prognosis for young women with breast cancer, *Lancet* 343:1587, 1994.
141. **Kroman N, Wohlfart J, Andersen KW, Mouriudsen HT, Westergaard U, Melbye M**, Time since childbirth and prognosis in primary breast cancer: population based study, *Br Med J* 315:851, 1997.
142. **Siwko SK, Dong J, Lewis MT, Liu H, Hilsenbeck SG, Li Y**, Evidence that an early pregnancy causes a persistent decrease in the number of functional mammary epithelial stem cells—implications for pregnancy-induced protection against breast cancer, *Stem Cells* 26:3205, 2008.
143. **Meduri G, Charnaux N, Spyrtos F, Hacene K, Loosfelt H, Milgrom E**, Luteinizing hormone receptor status and clinical, pathological, and prognostic features in patients with breast carcinomas, *Cancer* 97:1810, 2003.
144. **Russo IH, Russo J**, Primary prevention of breast cancer by hormone-induced differentiation, *Rec Results Cancer Res* 174:111, 2007.
145. **Lukanova A, Andersson R, Wulff M, Zelenluch-Jacquotte A, Grankvist K, Dossus L, Afanasyeva Y, Johansson R, Arsian AA, Lenner P, Wadell G, Hallmans G, Toniolo P, Lundin E**, Human chorionic gonadotropin and alpha-fetoprotein concentrations in pregnancy and maternal risk of breast cancer: a nested case-control study, *Am J Epidemiol* 168:1284, 2008.
146. **Jacobson HI, Lemanski N, Narendran A, Agarwal A, Bennett JA, Andersen TT**, Hormones of pregnancy, alpha-feto protein, and reduction of breast cancer risk, *Adv Exp Med Biol* 617:477, 2008.
147. **Andrieu N, Clavel F, Gairard B, Piana L, Bremond A, Lansac JH, Flamant R, Renaud R**, Familial risk of breast cancer and abortion, *Cancer Detect Prev* 18:51, 1994.
148. **Daling JR, Malone KE, Voigt LF, White E, Weiss NS**, Risk of breast cancer among young women: relationship to induced abortion, *J Natl Cancer Inst* 86:1584, 1994.
149. **Rookus MA, van Leeuwen FE**, Induced abortion and risk for breast cancer: reporting (recall) bias in a Dutch case-control study, *J Natl Cancer Inst* 88:1759, 1996.
150. **Melbye M, Wohlfahrt J, Olsen JH, Frisch M, Westergaard T, Helweg-Larsen K, Andersen PK**, Induced abortion and the risk of breast cancer, *N Engl J Med* 336:81, 1997.
151. **Ye Z, Gao DL, Qin Q, Ray RM, Thomas DB**, Breast cancer in relation to induced abortion in a cohort of Chinese women, *Br J Cancer* 87:977, 2002.
152. **Mahue-Giangreco M, Ursin G, Sullivan-Halley J, Berstein L**, Induced abortion, miscarriage, and breast cancer of young women, *Cancer Epidemiol Biomarkers Prev* 12:209, 2003.
153. **Reeves GK, Kan SW, Key T, et al.**, Breast cancer risk in relation to abortion: results from the EPIC study, *Int J Cancer* 119:1741, 2006.
154. **Michels KB, Xue F, Colditz GA, Willett WC**, Induced and spontaneous abortion and incidence of breast cancer among young women. A prospective cohort study, *Arch Intern Med* 167:814, 2007.
155. **Henderson KD, Sullivan-Halley J, Reynolds P, Horn-Ross PL, Clarke CA, Chang ET, Neuhausen S, Ursin G, Berstein L**, Incomplete pregnancy is not associated with breast cancer risk: the California Teachers Study, *Contraception* 77:391, 2008.
156. **Musey VC, Collins DC, Brogan DR, Santos VR, Musey PI, Martino-Saltzman D, Preedy JRK**, Long term effects of a first pregnancy on the hormonal environment: estrogens and androgens, *J Clin Endocrinol Metab* 64:111, 1987.
157. **Musey VC, Collins DC, Musey PI, Martino-Saltzman D, Preedy JRK**, Long-term effects of a first pregnancy on the secretion of prolactin, *N Engl J Med* 316:229, 1987.
158. **McTiernan A, Thomas DB**, Evidence for a protective effect of lactation on risk of breast cancer in young women: results from a case-control study, *Am J Epidemiol* 124:353, 1986.
159. **Layde PM, Webster LA, Baughman L, Wingo PA, Rubin GL, Ory HW**, The independent associations of parity, age at first full term pregnancy, and duration of breastfeeding with the risk of breast cancer, *J Clin Epidemiol* 42:963, 1989.

160. **United Kingdom National Case-Control Study Group**, Breast feeding and risk of breast cancer in young women, *Br Med J*, 307:17, 1993.
161. **Newcomb PA, Storer BE, Longnecker MP, Mittendorf R, Greenberg ER, Clapp RW, Burke KP, Willett WC, MacMahon B**, Lactation and a reduced risk of premenopausal breast cancer, *N Engl J Med* 330:81, 1994.
162. **Newcomb P, Egan KM, Titus-Ernstoff L, Trentham-Dietz A, Greenberg ER, Baron JA, Willett WC, Stampfer MJ**, Lactation in relation to postmenopausal breast cancer, *Am J Epidemiol* 150:174, 1999.
163. **Faheem M, Khurram M, Jafri IA, Mehmood H, Hasan Z, Iqbal GS, Maqsood F, Jafri SR**, Risk factors for breast cancer in patients treated at NORI hospital, Islamabad, *J Pak Med Assoc* 57:242, 2007.
164. **Kim Y, Choi JY, Lee KM, Park SK, Ahn SH, Noh DY, Hong YC, Kang D, Yoo KY**, Dose-dependent protective effect of breast-feeding against breast cancer among ever-lactated women in Korea, *Eur J Cancer Prev* 16:124, 2007.
165. **Shema L, Ore I, Ben-Shachar M, Haj M, Linn S**, The association between breastfeeding and breast cancer occurrence among Israeli Jewish women: a case-control study, *J Cancer Res Clin Oncol* 133:539, 2007.
166. **Jerström H, Lubinski J, Lynch HT, Ghadirian P, Neuhausen S, Isaacs C, Weber BL, Horsman D, Rosen B, Foulkes WD, Friedman E, Gershoni-Baruch R, Ainsorth P, Daly M, Garber JE, Olsson H, Sun P, Narod SA**, Breast-feeding and the risk of breast cancer in BRCA1 and BRCA2 mutation carriers, *J Natl Cancer Inst* 96:1094, 2004.
167. **Lee E, Ma H, McKean-Cowdin R, Van Den Berg D, Bernstein L, Henderson BE, Ursin G**, Effect of reproductive factors and oral contraceptives on breast cancer risk in BRCA1/2 mutation carriers and noncarriers: results from a population based study, *Cancer Epidemiol Biomarkers Prev* 17:3170, 2008.
168. **Kvåle G, Heuch I**, Lactation and cancer risk: is there a relation specific to breast cancer?, *J Epidemiol Community Health* 2:30, 1987.
169. **London SJ, Colditz GA, Stampfer MJ, Willett WC, Rosner BA, Corsano K, Speizer FE**, Lactation and the risk of breast cancer in a cohort of US women, *Am J Epidemiol* 132:17, 1990.
170. **Collaborative Group on Hormonal Factors in Breast Cancer**, Breast cancer and breastfeeding: collaborative reanalysis of individual data from 47 epidemiological studies in 30 countries, including 50,302 women with breast cancer and 96,973 women without disease, *Lancet* 360:187, 2002.
171. **Bernier MO, Plu-Bureau G, Bossard N, Ayzac L, Thalabard JC**, Breastfeeding and risk of breast cancer: a meta-analysis of published studies, *Hum Reprod Update* 6:374, 2000.
172. **Ing R, Ho JHC, Petrakis NL**, Unilateral breast-feeding and breast cancer, *Lancet* ii:124, 1977.
173. **Berkel H, Birdsell DC, Jenkins H**, Breast augmentation: a risk factor for breast cancer? *N Engl J Med* 326:1649, 1992.
174. **Deapen DM, Brody GS**, Augmentation mammoplasty and breast cancer: a 5-year update of the Los Angeles study, *Plast Reconstr Surg* 89:660, 1992.
175. **Malone KE, Stanford JL, Daling JR, Voigt LF**, Implants and breast cancer, *Lancet* 339:1365, 1992.
176. **Deapen DM, Bernstein L, Brody GS**, Are breast implants anticarcinogenic? A 14-year follow-up of the Los Angeles Study, *Plast Reconstr Surg* 99:1346, 1997.
177. **McLaughlin JK, Nyrén O, Blot WJ, Yin L, Josefsson S, Fraumeni JF Jr, Adami H-O**, Cancer risk among women with cosmetic breast implants: a population-based cohort study in Sweden, *J Natl Cancer Inst* 90:156, 1998.
178. **Friis S, Hölmich LR, McLaughlin JK, Kjøller K, Fryzek JP, Henriksen TF, Olsen JH**, Cancer risk among Danish women with cosmetic breast implants, *Int J Cancer* 118:998, 2006.
179. **Lipworth L, Tarone RE, Friis S, Ye W, Olsen JH, Nyren O, McLaughlin JK**, Cancer among Scandinavian women with cosmetic breast implants: a pooled long-term follow-up study, *Int J Cancer* 124:490, 2009.
180. **La Vecchia C, Negri E, Bruzzi P, Dardanoni G, Decarli A, Franceschi S, Palli D, Talamini R**, The role of age at menarche and at menopause on breast cancer risk: combined evidence from four case-control studies, *Ann Oncol* 3:625, 1992.
181. **Coulam CB, Annegers JF**, Breast cancer and chronic anovulation syndrome, *Surg Forum* 33:474, 1982.

182. **Coulam CB, Annegers JF, Krans JS**, Chronic anovulation syndrome and associated neoplasia, *Obstet Gynecol* 61:403, 1983.
183. **Cowan LD, Gordis L, Tonascia JA, Jones GS**, Breast cancer incidence in women with a history of progesterone deficiency, *Am J Epidemiol* 114:209, 1981.
184. **Ron E, Lunenfeld B, Menczer J, Blumstein T, Katz L, Oelsner G, Serr D**, Cancer incidence in a cohort of infertile women, *Am J Epidemiol* 125:780, 1987.
185. **Terry KL, Willett WC, Rich-Edwards JW, Michels KB**, A prospective study of infertility due to ovulatory disorders, ovulation induction, and incidence of breast cancer, *Arch Intern Med* 166:2484, 2006.
186. **Dupont WD, Page DL**, Risk factors for breast cancer in women with proliferative breast disease, *N Engl J Med* 312:146, 1985.
187. **Pearlman MD, Griffin JL**, Benign breast disease, *Obstet Gynecol* 2116:747, 2010.
188. **London SJ, Connolly JL, Schnitt SG, Colditz GA**, A prospective study of benign breast disease and the risk of breast cancer, *JAMA* 267:941, 1992.
189. **Fitzgibbons PL, Henson DE, Hutter RVP**; for the **Cancer Committee of the College of American Pathologists**, Benign breast changes and the risk for subsequent breast cancer. An update of the 1985 consensus statement, *Arch Pathol Lab Med* 122:1053, 1998.
190. **Collaborative Group on Hormonal Factors in Breast Cancer**, Familial breast cancer: collaborative reanalysis of individual data from 52 epidemiological studies including 58,209 women with breast cancer and 101,986 women without the disease, *Lancet* 358:1389, 2001.
191. **Hall JM, Lee MK, Newman B**, Linkage of early-onset familial breast cancer to chromosome 17q21, *Science* 250:1684, 1990.
192. **Jatoi I, Anderson WF**, Management of women who have a genetic predisposition for breast cancer, *Surg Clin North Am* 88:845, 2008.
193. **Ford D, Easton DF, Bishop DT, Narod SA, Goldgar DE**; and the **Breast Cancer Linkage Consortium**, Risks of cancer in BRCA1-mutation carriers, *Lancet* 343:692, 1994.
194. **Wooster R, Neuhausen SL, Mangion J, Quirk Y, Ford D, Collins N, Nguyen K, Seal S, Tran T, Averill D**, et al., Localization of a breast cancer susceptibility gene, BRCA2, to chromosome 13q12–13, *Science* 265:2088, 1994.
195. **Gayther SA, Mangion J, Russell P, Seal S, Barfoot R, Ponder BA, Stratton MR, Easton D**, Variation of risks of breast and ovarian cancer associated with different germline mutations of the BRCA2 gene, *Nat Genet* 15:103, 1997.
196. **Gayther SA, Ponder BA**, Mutations of the BRCA1 and BRCA2 genes and the possibilities for predictive testing, *Mol Med Today* 3:168, 1997.
197. **Stratton JF, Gayther SA, Russell P, Dearden J, Gore M, Blake P, Easton D, Ponder BA**, Contribution of BRCA1 mutations to ovarian cancer, *N Engl J Med* 336:1125, 1997.
198. **Rubin SG, Blackwood MA, Bandera C, Behbakht K, Benjamin I, Rebbeck TR, Boyd J**, BRCA1, BRCA2, and hereditary nonpolyposis colorectal cancer gene mutations in an unselected ovarian cancer population: relationship to family history and implications for genetic testing, *Am J Obstet Gynecol* 178:670, 1998.
199. **Miki Y, Swensen J, Shattuck-Eidens D, Futreal PA, Harshman K, Tavtigian S, Liu Q, Cochran C, Bennett LM, Ding W**, et al., A strong candidate for the breast and ovarian cancer susceptibility gene BRCA1, *Science* 266:66, 1994.
200. **Shattuck-Eidens D, McClure M, Simard J, Labrie F, Narod S, Couch F, Hoskins K, Weber B, Castilla L, Erdos M**, et al., A collaborative survey of 80 mutations in the BRCA1 breast and ovarian cancer susceptibility gene: implications for presymptomatic testing and screening, *JAMA* 273:535, 1995.
201. **Futreal PA, Liu Q, Shattuck-Eidens D, Cochran C, Harshman K, Tavtigian S, Bennett LM, Haugen-Strano A, Swensen J, Miki Y**, et al., BRCA1 mutations in primary breast and ovarian carcinomas, *Science* 266:120, 1994.
202. **Krainer M, Silva-Arrieta S, FitzGerald MG, Shaimada A, Ishioka C, Kanamaru R, MacDonald DJ, Unsal H, Finkelstein DM, Bowcock A, Isselbacher KJ, Haber DJ**, Differential contributions of BRCA1

and BRCA2 to early-onset breast cancer, *N Engl J Med* 336:1416, 1997.

203. **Struwing JP, Hartge P, Wacholder S, Baker SM, Berlin M, McAdams M, Timmerman MM, Brody LC, Tucker MA**, The risk of cancer associated with specific mutations of BRCA1 and BRCA2 among Ashkenazi Jews, *N Engl J Med* 336:1401, 1997.
204. **Newman B, Mu H, Butler LM, Millikan RC, Moorman PG, King M-C**, Frequency of breast cancer attributable to BRCA1 in a population-based series of American women, *JAMA* 279:915, 1998.
205. **Malone KE, Daling JR, Thompson JD, O'Brien CA, Francisco LV, Ostrander EA**, BRCA1 mutations and breast cancer in the general population. Analyses in women before age 35 years and in women before age 45 years with first-degree family history, *JAMA* 279:922, 1998.
206. **Lancaster JM, Powell CB, Chen LM, Richardson DL**, Society of Gynecologic Oncology statement on risk assessment for inherited gynecologic cancer predispositions, *Gynecol Oncol* 136:3, 2015.
207. **Chen S, Parmigiani G**, Meta-analysis of BRCA1 and BRCA2 penetrance. *J Clin Oncol* 25:1329, 2007.
208. **Chen S, Iversen ES, Friebel T, Finkelstein D, Weber BL, Eisen A, Peterson LE, Schildkraut JM, Isaacs C, Peshkin BN, Corio C, Leondaridis L, Tomlinson G, Dutson D, Kerber R, Amos CI, Strong LC, Berry DA, Euhus DM, Parmigiani G**, Characterization of BRCA1 and BRCA2 mutations in a large United States sample, *J Clin Oncol* 24:863, 2006.
209. **Thompson D, Easton DF; the Breast Cancer Linkage Consortium**, Cancer incidence in BRCA1 mutation carriers, *J Natl Cancer Inst* 94:1358, 2002.
210. **Tai YC, Domchek S, Parmigiani G, Chen S**, Breast cancer among male BRCA1 and BRCA2 mutation carriers, *J Natl Cancer Inst* 99:1811, 2007.
211. **The Breast Cancer Linkage Consortium**, Cancer risks in BRCA2 mutation carriers, *J Natl Cancer Inst* 91:1310, 1999.
212. **Breast Cancer Linkage Consortium**, Pathology of familial breast cancer: differences between breast cancers in carriers of BRCA1 or BRCA2 mutations and sporadic cases, *Lancet* 349:1505, 1997.
213. **Verhoog LC, Brekelmans CTM, Seynaeve C, van den Bosch LMC, Dahmen G, van Geel AN, Tilanus-Linthorst MMA, Bartels CCM, Wagner A, van den Ouweland A, Devilee P, Meijers-Heijboer EJ, Klijn JGM**, Survival and tumour characteristics of breast-cancer patients with germline mutations of BRCA1, *Lancet* 351:316, 1998.
214. **Meijers-Heijboer H, Wijnen J, Vasen H, Wasielewski M, Wagner A, Hollestelle A, Elstrodt F, van den Bos R, de Snoo A, Fat GT, Brekelmans C, Jagmohan S, Franken P, Verkuijlen P, van den Ouweland A, Chapman P, Tops C, Moslein G, Burn J, Lynch H, Klijn J, Fodde R, Schutte M**, The CHEK2 1100delC mutation identifies families with a hereditary breast and colorectal cancer phenotype, *Am J Hum Genet* 72:1308, 2003.
215. **Metcalfé KA, Finch A, Poll A, Horsman D, Kim-Sing C, Scott J, Royer R, Sun P, Narod SA**, Breast cancer risks in women with a family history of breast or ovarian cancer who have tested negative for a BRCA1 or BRCA2 mutation, *Br J Cancer* 100:421, 2009.
216. **National Comprehensive Cancer Network**, Genetic/familial high risk assessment: breast and ovarian. Version 2.2017. NCCN Clinical Practice Guidelines in Oncology. NCCN, Fort Washington, 2016.
217. **Robson M, Offit K**, Clinical practice: management of an inherited predisposition to breast cancer, *N Engl J Med* 357:154, 2007.
218. **Wooster R, Weber BL**, Breast and ovarian cancer, *N Engl J Med* 348:2339, 2003.
219. **Hartmann LC, Schaid DJ, Woods JE, Crotty TP, Myers JL, Arnold PG, Petty PM, Sellers TA, Johnson JL, McDonnell SK, Frost MH, Jenkins RB**, Efficacy of bilateral prophylactic mastectomy in women with a family history of breast cancer, *N Engl J Med* 340:77, 1999.
220. **Meijers-Heijboer H, van Geel B, van Putten WL, Henzen-Logmans SC, Seynaeve C, Menke-Pluymers MB, Bartels CC, Verhoog LC, van den Ouweland AM, Niermeijer MF, Brekelmans CT, Klijn JG**, Breast cancer after prophylactic bilateral mastectomy in women with a BRCA1 or BRCA2 mutation, *N Engl J Med* 345:159, 2001.
221. **Hartmann LC, Sellers TA, Schaid DJ, Frank TS, Soderberg CL, Sitta DL, Frost MH, Grant CS, Donohue JH, Woods JE, McDonnell SK, Vockley CW, Deffenbaugh A, Couch FJ, Jenkins RB**,

- Efficacy of bilateral prophylactic mastectomy in BRCA1 and BRCA2 gene mutation carriers, *J Natl Cancer Inst* 93:1633, 2001.
222. **Dowdy SC, Stefanek M, Hartmann LC.** Surgical risk reduction: prophylactic salpingo-oophorectomy and prophylactic mastectomy. *Am J Obstet Gynecol* 23:1113, 2004.
  223. **Frost MH, Schaid DJ, Sellers TA, Slezak JM, Arnold PG, Woods JE, et al.,** Long-term satisfaction and psychological and social function following bilateral prophylactic mastectomy. *JAMA* 24:319, 2000.
  224. **Brandberg Y, Sandelin K, Erikson S, Jurell G, Liljegren A, Lindblom A, et al.,** Psychological reactions, quality of life, and body image after bilateral prophylactic mastectomy in women at high risk for breast cancer: a prospective 1-year follow-up study. *J Clin Oncol* 26:3943, 2008.
  225. **Rebbeck TR, Levin AM, Eisen A, Snyder C, Watson P, Cannon-Albright L, Isaacs C, Olopade OI, Garber JE, Godwin AK, Daly MB, Narod SA, Neuhausen SL, Lynch HT, Weber BL,** Breast cancer risk after bilateral prophylactic oophorectomy in BRCA1 mutation carriers, *J Natl Cancer Inst* 91:1475, 1999.
  226. **Rebbeck TR, Lynch HT, Neuhausen SL, Narod S, Van't Veer L, Garber JE, Evans G, Isaacs C, Daly MB, Matloff E, Olopade OI, Weber BL; Prevention and Observation of Surgical End Points Study Group,** Prophylactic oophorectomy in carriers of BRCA1 or BRCA2 mutations, *N Engl J Med* 346:1616, 2002.
  227. **Narod S, Dube MP, Klijn J, Lubinski J, Lynch HT, Ghadirian P, Provencher D, et al.,** Oral contraceptives and the risk of breast cancer in BRCA1 and BRCA2 mutation carriers, *J Natl Cancer Inst* 94:1773, 2002.
  228. **Haile RW, Thomas DC, McGuire V, Felberg A, John EM, Milne R, Hopper JL, Jenkins MA, Levine AJ, Daly MM, Buys SS, Senie RT, Andrulis IL, Knight JA, Godwin AK, Southey M, McCredie MR, Giles GG, Andrews L, Tucker K, Miron A, Apicella C, Tesoriero A, Bane A, Pike MC; ConFab Investigators, Ontario Cancer Genetics Network Investigators, Whittemore AS,** BRCA1 and BRCA2 mutation carriers, oral contraceptive use, and breast cancer before age 50, *Cancer Epidemiol Biomarkers Prev* 15:1863, 2006.
  229. **Brohet RM, Goldgar DE, Easton DF, Antonious AC, Andrieu N, Chang-Claude J, Peock S, Eeles RA, Cook M, Chu C, Noguès C, Lasset C, Berthet P, Meijers-Heijboer H, Gerdes AM, Olsson H, Caldes T, van Leeuwen FE, Rookus MA,** Oral contraceptives and breast cancer risk in the international BRCA1/2 carrier cohort study: a report from EMBRACE, GENEPSO, GEO-HEBON, and the IBCCS Collaborating Group, *J Clin Oncol* 25:3831, 2007.
  230. **Milne RL, Knight JA, John EM, Dite GS, Balbuena R, Ziogas A, Andrulis IL, West DW, Li FP, Southey MC, Giles GG, McCredie MR, Hopper JL, Whittemore AS,** Oral contraceptive use and risk of early-onset breast cancer in carriers and noncarriers of BRCA1 and BRCA2 mutations, *Cancer Epidemiol Biomarkers Prev* 14:350, 2005.
  231. **Figueiredo JC, Haile RW, Bernstein L, Malone KE, Largent J, Langholz B, Lynch CF, Bertelsen L, Capanu M, Concannon P, Borg A, Børresen-Dale AL, Diep A, Teraoka S, Torngren T, Xue S, Berstein JL,** Oral contraceptives and postmenopausal hormones and risk of contralateral breast cancer among BRCA1 and BRCA2 mutation carriers and noncarriers: the WECARE Study, *Breast Cancer Res Treat* 120:175, 2010.
  232. **Fisher B, Costantino JP, Wickerham DL, Redmond CK, Kavanah M, Cronin WM, Vogel V, Robidoux A, Dimitrov N, Atkins J, Daly M, Wieand S, Tan-Chiu E, Ford L, Wolmark N; Other National Surgical Adjuvant Breast and Bowel Project Investigators,** Tamoxifen for prevention of breast cancer: report of the National Surgical Adjuvant Breast and Bowel Project P-1 Study, *J Natl Cancer Inst* 90:1371, 1998.
  233. **Fisher B, Costantini JP, Wickerham DL, Cecchini RS, Cronin WM, Robidoux A, Bevers TB, Kavanah MT, Atkins JN, Margolese RG, Runowicz CD, James JM, Ford LG, Wolmark N,** Tamoxifen for the prevention of breast cancer: current status of the National Surgical Adjuvant Breast and Bowel Project P-1 Study, *J Natl Cancer Inst* 97:1652, 2005.
  234. **Nelson HD, Smith ME, Griffin JC, Fu R,** Use of medications to reduce risk for primary breast cancer: a systematic review for the U.S. Preventative Services Task Force, *Ann Intern Med* 158:604, 2013.
  235. **Cuzick J, Sestak I, Forbes JF, Dowsett M, Knox J, et al.,** Anastrozole for prevention of breast cancer in

high-risk postmenopausal women (IBIS-II): an international, double-blind, randomized placebo-controlled trial, *Lancet* 383:1040, 2014.

236. **Rebbeck TR, Friebel T, Wagner T, Lynch HT, Garber JE, Daly MB, Isaacs C, Olopade OI, Neuhausen SL, van't Veer L, Eeles R, Evans DG, Tomlinson G, Matloff E, Narod SA, Eisen A, Domchek S, Armstrong K, Weber BL**, Effect of short-term hormone replacement therapy on breast cancer risk reduction after bilateral prophylactic oophorectomy in BRCA1 and BRCA2 mutation carriers: the PROSE study, *J Clin Oncol* 23:7804, 2005.
237. **Eisen A, Lubinski J, Gronwald J, Moller P, Lynch HT, Kim-Sing C, Neuhausen SL, Gilbert L, Ghadirian P, Manoukian S, Rennert G, Friedman E, Isaacs C, Rosen E, Rosen B, Daly M, Sun P, Narod SA; Hereditary Breast Cancer Clinical Study Group**, Hormone therapy and the risk of breast cancer in BRCA1 mutation carriers, *J Natl Cancer Inst* 100:1361, 2008.
238. **Carroll KK**, Experimental studies on dietary fat and cancer in relation to epidemiological data, *Prog Clin Biol Res* 222:231, 1986.
239. **Willett WC, Browne ML, Bain C, Lipnick RJ, Stampfer MJ, Rosner B, Colditz GA, Hennekens CH, Speizer FE**, Relative weight and risk of breast cancer among premenopausal women, *Am J Epidemiol* 122:731, 1985.
240. **Jones DY, Schatzkin A, Green SB, Block G, Brinton LA, Ziegler RG, Hoover R, Taylor PR**, Dietary fat and breast cancer in the National Health and Nutrition Examination Survey Epidemiologic Follow-up Study, *J Natl Cancer Inst* 79:465, 1987.
241. **Willett WC, Hunter DJ, Stampfer MJ, Colditz G, Manson JE, Spiegelman D, Rosner B, Hennekens CH, Speizer FE**, Dietary fat and fiber in relation to risk of breast cancer: an 8-year follow-up, *JAMA* 268:2037, 1992.
242. **Hunter DJ, Spiegelman D, Adami H-O, Beeson L, van den Brandt PA, Folsom AR, Fraser GE, Goldbohm A, Graham S, Howe GR, Kushi LH, Marshall JR, McDermott A, Miller AB, Speizer FE, Wolk A, Yaun S-S, Willett W**, Cohort studies of fat intake and the risk of breast cancer—a pooled analysis, *N Engl J Med* 334:356, 1996.
243. **Byrne C, Rockett H, Holmes MD**, Dietary fat, fat subtypes, and breast cancer risk: lack of an association among postmenopausal women with no history of benign breast disease, *Cancer Epidemiol Biomarkers Prev* 11:261, 2003.
244. **Howe GR, Hirohata R, Hislop TG, Iscovich JM, Yuan JM, Katsouyami K, Lubin F, Marubini E, Modan B, Rohan T, et al.**, Dietary factors and risk of breast cancer: Combined analysis of 12 case-control studies, *J Natl Cancer Inst* 82:561, 1990.
245. **Cho E, Spiegelman D, Hunter DJ, Chen WY, Stampfer MJ, Colditz GA, Willett WC**, Premenopausal fat intake and risk of breast cancer, *J Natl Cancer Inst* 95:1079, 2003.
246. **Kushi LH, Sellers TA, Potter JD, Nelson CL, Munger RG, Kaye SA, Folsom AR**, Dietary fat and postmenopausal breast cancer, *J Natl Cancer Inst* 84:1092, 1992.
247. **Sieri S, Krogh V, Ferrari P, Berrino F, Pala V, Thiébaud AC, Tjønneland A, et al.**, Dietary fat and breast cancer risk in the European Prospective Investigation into Cancer and Nutrition, *Am J Clin Nutr* 88:1304, 2008.
248. **Schapira DV, Clark RA, Wolff PA, Jarrett A, Kumar NB, Aziz NM**, Visceral obesity and breast cancer risk, *Cancer* 74:632, 1994.
249. **McTiernan A, Kooperberg C, White E, Wilcox S, Coates RJ, Adams-Campbell LL, Woods N, Ockene J; Women's Health Initiative Cohort Study**, Recreational physical activity and the risk of breast cancer in postmenopausal women: the Women's Health Initiative Cohort Study, *JAMA* 290:1331, 2003.
250. **Bruning PF, Bonfrère JMG, van Noord PAH, Hart AAM, De Jong-Bakker M, Nooijen WJ**, Insulin resistance and breast cancer risk, *Int J Cancer* 52:511, 1992.
251. **Thune I, Brenn T, Lund E, Gaard M**, Physical activity and the risk of breast cancer, *N Engl J Med* 336:1269, 1997.
252. **Gunter MJ, Hoover DR, Yu HWassertheil-Smoller S, Rohan T, Manson JE, Li J, Ho GYF, Xue X, Anderson GL, Kaplan RC, Harris TG, Howard BV, Wylie-Rosett J, Burk RD, Strickler HD**, Insulin, insulin-like growth factor-I, and risk of breast cancer in postmenopausal women, *J Natl Cancer Inst* 101:48,

2009.

253. **Goodman MT, Wilkens LR, Hankin JH, Lyu L-C, Wu AH, Kolonel LN**, Association of soy and fiber consumption with the risk of endometrial cancer, *Am J Epidemiol* 146:294, 1997.
254. **Ingram D, Sanders K, Kolybaba M, Lopez D**, Case-control study of phyto-oestrogens and breast cancer, *Lancet* 350:990, 1997.
255. **Zhang C, Ho SC, Cheng S, Fu J, Chen Y**, Soy product and isoflavone intake and breast cancer risk defined by hormone receptor status, *Cancer Sci* 101(2):501, 2010.
256. **Messina MJ, Persky V, Setchell KDR, Barnes S**, Soy intake and cancer risk: a review of the in vitro and in vivo data, *Nutr Cancer* 21:113, 1994.
257. **Petrakis NL, Barnes S, King EB, Lowenstein J, Wiencke J, Lee MM, Müike R, Kirk M, Coward L**, Stimulatory influence of soy protein isolate on breast secretion in pre- and postmenopausal women, *Cancer Epidemiol Biomarkers Prev* 5:785, 1996.
258. **Hargreaves DF, Potten CS, Harding C, Shaw LE, Morton MS, Roberts SA, Howell A, Bundred NJ**, Two-week dietary soy supplementation has an estrogenic effect on normal premenopausal breast, *J Clin Endocrinol Metab* 84:4017, 1999.
259. **McMichael-Phillips DF, Harding C, Morton M, Roberts SA, Howell A, Potten CS, Bundred NJ**, Effects of soy-protein supplementation on epithelial proliferation in the histologically normal breast, *Am J Clin Nutr* 68(Suppl):1431S, 1998.
260. **Deapen D, Liu L, Perkins C, Bernstein L, Ross RK**, Rapidly rising breast cancer incidence rates among Asian-American women, *Int J Cancer* 99:747, 2002.
261. **Wu AH, Ziegler RG, Pike MC, Nomura AMY, West DW, Kolonel LN, Horn-Ross PL, Rosenthal JF, Hoover RN**, Menstrual and reproductive factors and risk of breast cancer in Asian-Americans, *Br J Cancer* 73:680, 1996.
262. **Ziegler RG, Hoover RN, Nomura AM, West DW, Wu AH, Pike MC, Lake AJ, Horn-Ross PL, Kolonel LN, Siitleri PK, Fraumeni JF Jr**, Relative weight, weight change, height, and breast cancer risk in Asian-American women, *J Natl Cancer Inst* 88:650, 1996.
263. **Potischman N, Swanson CA, Siitleri P, Hoover RN**, Reversal of relation between body mass and endogenous estrogen concentrations with menopausal status, *J Natl Cancer Inst* 88:756, 1996.
264. **Yong L-C, Brown CC, Schatzkin A, Schairer C**, Prospective study of relative weight and risk of breast cancer: the Breast Cancer Detection Demonstration Project follow-up study, 1979 to 1987–1989, *Am J Epidemiol* 143:985, 1996.
265. **Morimoto LM, White E, Chen Z, Chlebowski RT, Hays J, Kuller L, Lopez AM, Manson JE, Margolis KL, Muti PC, Stefanick ML, McTiernan A**, Obesity, body size, and risk of postmenopausal breast cancer: the Women's Health Initiative (United States), *Cancer Causes Control* 13:741, 2002.
266. **Ahn J, Schatzkin A, Lacey JV Jr, Albanes D, Ballard-Barbash R, Adams KF, Kipnis V, Mouw T, Hollenbeck AR, Letizmann MF**, Adiposity, adult weight change, and postmenopausal breast cancer risk, *Arch Intern Med* 167:2091, 2007.
267. **Sherman B, Wallace R, Beam J, Schlabaugh L**, Relationship of body weight to menarcheal and menopausal age: implication for breast cancer risk, *J Clin Endocrinol Metab* 52:488, 1981.
268. **Magnusson C, Baron J, Persson I, Wolk A, Bergström R, Trichopoulos D, Adami H-O**, Body size in different periods of life and breast cancer risk in post-menopausal women, *Int J Cancer* 76:29, 1998.
269. **Welti LM, Beavers DP, Caan BJ, Sangi-Haghpeykar H, Vitolins MZ, Beavers KM**, Weight fluctuation and cancer risk in postmenopausal women: the Women's Health Initiative, *Cancer Epidemiol Biomarkers Prev* 26:779, 2017.
270. **Kushi LH, Fee RM, Sellers TA, Zheng W, Folsom AR**, Intake of vitamins A, C, and E and postmenopausal breast cancer. The Iowa Women's Health Study, *Am J Epidemiol* 144:165, 1996.
271. **Longnecker MP**, Alcoholic beverage consumption in relation to risk of breast cancer: meta-analysis and review, *Cancer Causes Control* 5:73, 1995.
272. **Suzuki R, Ye W, Rylander-Rudqvist T, Saji S, Colditz GA, Wolk A**, Alcohol and postmenopausal breast cancer risk defined by estrogen and progesterone receptor status: a prospective cohort study, *J Natl Cancer*

Inst 97:1601, 2005.

273. **Fentiman IS**, Fixed and modifiable risk factors for breast cancer, *Int J Clin Pract* 55:527, 2001.
274. **Li Y, Baer D, Friedman GD, Udaltsova N, Shim V, Klatsky AL**, Wine, liquor, beer and risk of breast cancer in a large population, *Eur J Cancer* 45:843, 2009.
275. **Dorgan JF, Reichman ME, Judd JT, Brown C, Longcope C, Schatzkin A, Campbell WS, Franz C, Kahle L, Taylor PR**, The relation of reported alcohol ingestion to plasma levels of estrogens and androgens in premenopausal women, *Cancer Causes Control* 5:53, 1994.
276. **Gavaler JS, Van Thiel DH**, The association between moderate alcoholic beverage consumption and serum estradiol and testosterone levels in normal postmenopausal women: relationship to the literature, *Alcohol Clin Exp Res* 16:87, 1992.
277. **Ginsburg EL, Mello NK, Mendelson JH, Barbieri RL, Teoh SK, Rothman M, Gao X, Sholar JW**, Effects of alcohol ingestion on estrogens in postmenopausal women, *JAMA* 276:1747, 1996.
278. **Dorgan JF, Baer DJ, Albert PS, Judd JT, Brown ED, Corkle DK, Campbell WS, Hartman TJ, Tejpar AA, Clevidence BA, Giffen CA, Chandler DW, Stanczyk FZ, Taylor PR**, Serum hormones and the alcohol-breast cancer association in postmenopausal women, *J Natl Cancer Inst* 93:710, 2001.
279. **Muti P, Trevisan M, Micheli A, Krogh V, Boelli G, Sciajno R, Schünemann HJ, Berrino F**, Alcohol consumption and total estradiol in premenopausal women, *Cancer Epidemiol Biomarkers Prev* 7:189, 1998.
280. **Bulbrook RD**, Urinary androgen excretion and the etiology of breast cancer, *J Natl Cancer Inst* 48:1039, 1972.
281. **Wang DY, Allen DS, De Stavola BL, Fentiman IS, Brussen J, Bulbrook RD, Thomas BS, Hayward JL, Reed MJ**, Urinary androgens and breast cancer risk: results from a long-term prospective study based in Guernsey, *Br J Cancer* 82:1577, 2000.
282. **Lemon HM**, Estriol prevention of mammary carcinoma induced by 7,12-dimethylbenz(a)anthracene, *Cancer Res* 35:1341, 1975.
283. **Dickinson LE, MacMahon B, Cole P, Brown JB**, Estrogen profiles of Oriental and Caucasian women in Hawaii, *N Engl J Med* 291:1211, 1974.
284. **Ziegler RG, Fuhrman BJ, Xu X, Gail MH, Keefer LK, Veenstra TD, Hoover RN**, In Asian-American women, Westernization influences estrogen metabolism, but not total endogenous estrogen production, *San Antonio Breast Cancer Symposium, Abstract 3063, December 9–13, 2009*.
285. **Katzenellenbogen BS**, Biology and receptor interactions of estriol and estriol derivatives in vitro and in vivo, *J Steroid Biochem* 20:1033, 1984.
286. **Melamed M, Castraño E, Notides AC, Sasson S**, Molecular and kinetic basis for the mixed agonist/antagonist activity of estriol, *Mol Endocrinol* 11:1868, 1997.
287. **Estavão RA, Baracat EC, Logullo AF, Oshima CT, Nazário AC**, Efficacy of estriol in inhibiting epithelial proliferation in mammary fibroadenoma: randomized clinical trial, *Sao Paulo Med J* 125:343, 2007.
288. **The Endogenous Hormones and Breast Cancer Collaborative Group**, Endogenous sex hormones and breast cancer in postmenopausal women: reanalysis of nine prospective studies, *J Natl Cancer Inst* 94:606, 2002.
289. **Brusselaers N, Tamimi RM, Konings P, Rosner B, Adami HO, Lagergren J**, Different menopausal hormone regimens and risk of breast cancer, *Ann Oncol* 29(8):1771, 2018.
290. **Kaaks R, Rinaldi S, Key TJ, Berrino F, Peeters PH, Biessy C, Dossus L, et al.**, Postmenopausal serum androgens, oestrogens and breast cancer risk: the European prospective investigation into cancer and nutrition, *Endocr Relat Cancer* 12:1071, 2005.
291. **Eliassen AH, Missmer SA, Tworoger SS, Spiegelman D, Barbieri RL, Dowsett M, Hankinson SE**, Endogenous steroid hormone concentrations and risk of breast cancer among premenopausal women, *J Natl Cancer Inst* 98:1406, 2006.
292. **Key TJ, Appleby PN, Reeves GK, Roddam A, Dorgan JF, Longcope C, Stanczyk FZ, et al.; Endogenous Hormones Breast Cancer Collaborative Group**, Body mass index, serum sex hormones, and breast cancer risk in postmenopausal women, *J Natl Cancer Inst* 95:1218, 2003.
293. **Rinaldi S, Key TJ, Peeters PH, Lahmann P, Lukanova A, Dossus L, Biessy C, et al.**, Anthropometric



measures, endogenous sex steroids and breast cancer risk in postmenopausal women: a study within the EPIC cohort, *Int J Cancer* 118:2832, 2006.

294. **Zhang Y, Kel DP, Kreger BE, Cupples LA, Ellison RC, Dorgan JE, Schatzkin A, Levy D, Felson DT**, Bone mass and the risk of breast cancer among postmenopausal women, *N Engl J Med* 336:611, 1997.
295. **Nguyen TV, Center JR, Eisman JA**, Association between breast cancer and bone mineral density: the Dubbo Osteoporosis Epidemiology Study, *Maturitas* 36:27, 2000.
296. **van der Klift M, de Laet CE, Coebergh JW, Hofman A, Pols HA; Rotterdam Study**, Bone mineral density and the risk of breast cancer: the Rotterdam Study, *Bone* 32:211, 2003.
297. **Thompson WD, Jacobson HI, Negrini B, Janerich DT**, Hypertension, pregnancy, and risk of breast cancer, *J Natl Cancer Inst* 81:1571, 1989.
298. **Ekbom A, Trichopoulos D, Adami H-O, Hsieh C-C, Lan S-J**, Evidence of prenatal influences on breast cancer risk, *Lancet* 340:1015, 1992.
299. **Key TJA, Pike MC**, The role of oestrogens and progestogens in the epidemiology and prevention of breast cancer, *Eur J Cancer Clin Oncol* 24:29, 1988.
300. **Henderson BE, Ross RK, Judd HL, Krailo MD, Pike MC**, Do regular ovulatory cycles increase breast cancer risk?, *Cancer* 56:1206, 1985.
301. **Anderson TJ, Ferguson DJP, Raab GM**, Cell turnover in the “resting” human breast: influence of parity, contraceptive pill, age and laterality, *Br J Cancer* 46:376, 1982.
302. **Gompel A, Malet C, Spritzer P, Lalardrie J-P, Kuttenn F, Mauvais-Jarvis P**, Progestin effect on cell proliferation and 17-hydroxysteroid dehydrogenase activity in normal human breast cells in culture, *J Clin Endocrinol Metab* 63:1174, 1986.
303. **Helzlsouer KJ, Alberg AJ, Bush TL, Longcope C, Gordon GB, Comstock GW**, A prospective study of endogenous hormones and breast cancer, *Cancer Detect Prev* 18:79, 1994.
304. **Mørch LS, Skovlund CW, Hannaford PC, Iversen L, Fielding S, Lidegaard Ø**, Contemporary hormonal contraception and the risk of breast cancer, *N Engl J Med* 377:2228, 2017.
305. **Marchbanks PA, McDonald JA, Wilson HG, Folger SG, Mandel MG, Daling JR, Bernstein L, Malone KE, Ursin G, Strom BL, Norman SA, Wingo PA, Burkman RT, Berlin JA, Simon JS, Spirtas R, Weiss LK**, Oral contraceptives and the risk of breast cancer, *N Engl J Med* 346:2025, 2002.
306. **Figueiredo JC, Bernstein L, Capanu M, Malone KE, Lynch CF, Anton-Culver H, Stovall M, Bertelsen L, Haile RW, Bernstein JL**, Oral contraceptives, postmenopausal hormones, and risk of asynchronous bilateral breast cancer: the WECARE Study Group, *J Clin Oncol* 26:1411, 2008.
307. **Wingo PA, Austin H, Marchbanks PA, Whitman MK, Hsia J, Mandel MG, Peterson HB, Ory HW**, Oral contraceptives and the risk of death from breast cancer, *Obstet Gynecol* 110:793, 2007.
308. **Trivers KF, Gammon MD, Abrahamson PE, Lund MJ, Flagg EW, Moorman PG, Kaufman JS, Cai J, Porter PL, Brinton LA, Eley JW, Coates RJ**, Oral contraceptives and survival in breast cancer patients aged 20 to 54 years, *Cancer Epidemiol Biomarkers Prev* 16:1822, 2007.
309. **Nyante SJ, Gammon MD, Malone KE, Daling JR, Brinton LA**, The association between oral contraceptive use and lobular and ductal breast cancer in young women, *Int J Cancer* 122:936, 2007.
310. **Holmberg L, Lund E, Bergstrom R, Adami HO, Merik O**, Oral contraceptives and prognosis in breast cancer: effects of duration, latency, recency, age at first use and relation to parity and body mass index in young women with breast cancer, *Eur J Cancer* 30A:351, 1994.
311. **Charreau I, Plu-Bureau G, Bachelot A, Contesso G, Guinebretiere JM, L'e MG**, Oral contraceptive use and risk of benign breast disease in a French case-control study of young women, *Eur J Cancer Prev* 2:147, 1993.
312. **Rohan TE, Miller AB**, A cohort study of oral contraceptive use and risk of benign breast disease, *Int J Cancer* 82:191, 1999.
313. **Byrne C, Schairer C, Wolfe J, Parekh N, Salane M, Brinton LA, Hoover R, Haile R**, Mammographic features and breast cancer risk: effects with time, age, and menopause status, *J Natl Cancer Inst* 87:1622, 1995.
314. **Boyd NF, Martin LJ, Rommens JM, Paterson AD, Minkin S, Yaffe MJ, Stone J, Hopper JL**,

- Mammographic density: a heritable risk factor for breast cancer, *Methods Mol Biol* 472:343, 2009.
315. **Stone J, Dite GS, Gunasekara A, English DR, McCredie MR, Giles GG, Cawson JN, Hegele RA, Chiarelli AM, Yaffe MJ, Boyd NF, Hopper JL**, The heritability of mammographically dense and nondense breast tissue, *Cancer Epidemiol Biomarkers Prev* 15:612, 2006.
  316. **Douglas JA, Roy-Gagnon MH, Zhou C, Mitchell BD, Shuldiner AR, Chan HP, Helvie MA**, Mammographic breast density—evidence for genetic correlations with established breast cancer risk factors, *Cancer Epidemiol Biomarkers Prev* 17:3509, 2008.
  317. **Rutter CM, Mandelson MT, Laya MB, Seger DJ, Taplin S**, Changes in breast density associated with initiation, discontinuation, and continuing use of hormone replacement therapy, *JAMA* 285:171, 2001.
  318. **Berkowitz JE, Gatewood OMB, Goldblum LE, Gayler BW**, Hormonal replacement therapy: mammographic manifestations, *Radiology* 174:199, 1990.
  319. **Harvey JA, Pinkerton JV, Herman CR**, Short-term cessation of hormone replacement therapy and improvement of mammographic specificity, *J Natl Cancer Inst* 89:1623, 1997.
  320. **Colacurci N, Fornaro F, De Franciscis P, Mele E, Palermo M, del Vecchio W**, Effects of a short-term suspension of hormone replacement therapy on mammographic density, *Fertil Steril* 76:451, 2001.
  321. **Buist DS, Anderson ML, Reed SD, Aiello Bowles EJ, Fitzgibbons ED, Gandara JC, Seger D, Newton KM**, Short-term hormone therapy suspension and mammography recall: a randomized trial, *Ann Intern Med* 150:752, 2009.
  322. **Weaver K, Kataoka M, Murray J, Muir B, Anderson E, Warren R, Warsi I, Highnam R, Glasier A**, Does a short cessation of HRT decrease mammographic density? *Maturitas* 59:315, 2008.
  323. **Lundström E, Bygdesson M, Svane G, Azavedo E, Von Schoultz B**, Neutral effect of ultra-low-dose continuous combined estradiol and norethisterone acetate on mammographic breast density, *Climacteric* 10:249, 2007.
  324. **Bibbo M, Haenszel W, Wied GL, Hubby M, Herbst AL**, A twenty-five year follow-up study of women exposed to DES during pregnancy, *N Engl J Med* 298:763, 1978.
  325. **Greenburg ER, Barnes AB, Resseguie L, Barrett JA, Burnside S, Lanza LL, Neff RK, Stevens M, Young RH, Colton T**, Breast cancer in mothers given diethylstilbestrol in pregnancy, *N Engl J Med* 311:1393, 1984.
  326. **Colton T, Greenberg ER, Noller K, Resseguie L, Van Bennekom C, Heeren T, Zhang Y**, Breast cancer in mothers prescribed diethylstilbestrol in pregnancy, *JAMA* 269:2096, 1993.
  327. **Calle EE, Mervis CA, Thun MJ, Rodriguez C, Wingo PA, Heath CW Jr**, Diethylstilbestrol and risk of fatal breast cancer in a prospective cohort of US women, *Am J Epidemiol* 144:645, 1996.
  328. **Pallmer JR, Wise LA, Hatch EE, Troisi R, Titus-Ernstoff L, Strohsnitter W, Kaufman R, Herbst AL, Noller KL, Hyer M, Hoover RN**, Prenatal diethylstilbestrol exposure and risk of breast cancer, *Cancer Epidemiol Biomarkers Prev* 15:1509, 2006.
  329. **Hoover RN, Hyer M, Pfeiffer RM, Adam E, Bond B, Cheville AL, Colton T, Hartge P, Hatch EE, Herbst AL, Karlan BY, Kaufman R, Noller KL, Palmer JR, Robboy SJ, Saal RC, Strohsnitter W, Titus-Ernstoff L, Troisi R**, Adverse health outcomes in women exposed in utero to diethylstilbestrol. *N Engl J Med* 365(14):1304, 2011.
  330. **McGuire WL, Clark GM**, Prognostic factors and treatment decisions in axillary-node-negative breast cancer, *N Engl J Med* 326:1756, 1992.
  331. **Arpino G, Weiss H, Lee AV, Schiff R, De Placido S, Osborne CK, Elledge RM**, Estrogen receptor-positive, progesterone receptor-negative breast cancer: association with growth factor receptor expression and tamoxifen resistance, *J Natl Cancer Inst* 97:1254, 2005.
  332. **Early Breast Cancer Trialists' Collaborative Group**, Tamoxifen for early breast cancer, *Cochrane Database Syst Rev* CD000486, 2001.
  333. **Early Breast Cancer Trialists' Collaborative Group**, Effects of chemotherapy and hormonal therapy for early breast cancer on recurrence and 15-year survival: an overview of randomised trials, *Lancet* 365:1687, 2005.
  334. **Swedish Breast Cancer Cooperative Group**, Randomized trial of two versus five years of adjuvant

tamoxifen for postmenopausal early stage breast cancer, *J Natl Cancer Inst* 88:1543, 1996.

335. **Fisher B, Dignam J, Bryant J, Wolmark N**, Five versus more than five years of tamoxifen for lymph node-negative breast cancer: updated findings from the National Surgical Adjuvant Breast and Bowel Project B-14 randomized trial, *J Natl Cancer Inst* 93:684, 2001.
336. **Stewart HJ, Prescott RJ, Forest APM**, Scottish adjuvant tamoxifen trial: a randomized study updated to 15 years, *J Natl Cancer Inst* 93:456, 2001.
337. **Davies C, Pan H, Godwin J, Gray R, Arriagada R, et al.**, Long-term effects of continuing adjuvant tamoxifen to 10 years versus stopping at 5 years after diagnosis of oestrogen receptor-positive breast cancer: ATLAS, a randomized trial, *Lancet* 381:805, 2013.
338. **Brauch H, Jordan VC**, Targeting of tamoxifen to enhance antitumour action for the treatment and prevention of breast cancer: the 'personalized' approach? *Eur J Cancer* 45:2274, 2009.
339. **Lash TL, Lien EA, Sørensen HT, Hamilton-Dutoit S**, Genotype-guided tamoxifen therapy: time to pause for reflection? *Lancet Oncol* 10:825, 2009.
340. **Powles TJ, Hickish T, Kanis JA, Tidy A, Ashley S**, Effect of tamoxifen on bone mineral density measured by dual-energy x-ray absorptiometry in healthy premenopausal and postmenopausal women, *J Clin Oncol* 14:78, 1996.
341. **Bentley CR, Davies G, Aclimandos WA**, Tamoxifen retinopathy: a rare but serious complication, *Br Med J* 304:495, 1992.
342. **Pavlidis NA, Petris C, Briassoulis E, Klouvas G, Psilas C, Rempapis J, Petroutsos G**, Clear evidence that long-term low-dose tamoxifen treatment can induce ocular toxicity, *Cancer* 69:2961, 1992.
343. **Saphner T, Tormey DC, Gray R**, Venous and arterial thrombosis in patients who received adjuvant therapy for breast cancer, *J Clin Oncol* 9:286, 1991.
344. **Caleffi M, Fentiman IS, Clark GM, Wang DY, Needham J, Clark K, La Ville A, Lewis B**, Effect of tamoxifen on oestrogen binding, lipid and lipoprotein concentrations and blood clotting parameters in premenopausal women with breast pain, *J Endocrinol* 119:335, 1988.
345. **Helgason S, Wilking N, Carlstrom K, Damber MG, von Schoultz B**, A comparative study of the estrogenic effects of tamoxifen and 17 $\beta$ -estradiol in postmenopausal women, *J Clin Endocrinol Metab* 54:404, 1982.
346. **Costantino JP, Kuller LH, Ives DG, Fisher B, Dignam J**, Coronary heart disease mortality and adjuvant tamoxifen therapy, *J Natl Cancer Inst* 89:776, 1997.
347. **Reis SE, Costantino JP, Wickerham DL, Tan-Chiu E, Wang J-P, Kavanah M; for the National Surgical Adjuvant Breast and Bowel Project Breast Cancer Prevention Trial Investigators**, Cardiovascular effects of tamoxifen in women with and without heart disease: breast cancer prevention trial, *J Natl Cancer Inst* 93:16, 2001.
348. **Fisher B, Costantino JP, Redmond CK, Fisher ER, Wickerham DL, Cronin WM; Other NSABP Contributors**, Endometrial cancer in tamoxifen-treated breast cancer patients: findings from the National Surgical Adjuvant Breast and Bowel Project (NSABP) B-14, *J Natl Cancer Inst* 86:527, 1994.
349. **Rutqvist LE, Johansson H, Signomklao T, Johansson U, Fornander T, Wilking N**, Adjuvant tamoxifen therapy for early stage breast cancer and second primary malignancies. Stockholm Breast Cancer Study Group, *J Natl Cancer Inst* 87:645, 1995.
350. **Lahti E, Blanco G, Kauppila A, Apaja-Sarkkinen M, Taskinen PJ, Laatikainen T**, Endometrial changes in postmenopausal breast cancer patients receiving tamoxifen, *Obstet Gynecol* 81:660, 1993.
351. **Cohen I, Rosen DJD, Altaras M, Beyth Y, Shapira J, Yigael D**, Tamoxifen treatment in premenopausal breast cancer patients may be associated with ovarian overstimulation, cystic formations and fibroid overgrowth, *Br J Cancer* 69:620, 1994.
352. **Cohen I, Figer A, Tepper R, Shapira J, Altaras MM, Yigael D, Beyth Y**, Ovarian overstimulation and cystic formation in premenopausal tamoxifen exposure: comparison between tamoxifen-treated and nontreated breast cancer patients, *Gynecol Oncol* 72:202, 1999.
353. **Ebert AD, Rosenow G, David M, Mechsner S, Magalov IS, Papadopoulos T**, Co-occurrence of atypical endometriosis, subserous uterine leiomyomata, sactosalpinx, serous cystadenoma and bilateral hemorrhagic

corpora lutea in a perimenopausal adipose patient taking tamoxifen (20 mg/day) for invasive lobular breast cancer, *Gynecol Obstet Invest* 66:209, 2008.

354. **Powles TJ, Bourne T, Athanasious S, Chang J, Grubock K, Ashley S, Oakes L, Tidy A, Davey J, Viggers J, Humphries S, Collins W**, The effects of norethisterone on endometrial abnormalities identified by transvaginal ultrasound screening of healthy post-menopausal women on tamoxifen or placebo, *Br J Cancer* 78:272, 1998.
355. **Rose PG, Brandewie EV, Abdul-Karim FW**, Failure of megestrol acetate to reverse tamoxifen induced endometrial neoplasia: two case reports, *Int J Gynecol Cancer* 9:362, 1999.
356. **Gardner FJE, Konje JC, Abrams KR, Brown LJR, Khanna S, Al-Azzawi F, Bell SC, Taylor DJ**, Endometrial protection from tamoxifen-stimulated changes by a levonorgestrel-releasing intrauterine system: a randomised controlled trial, *Lancet* 356:1711, 2000.
357. **Kesim MD, Aydin Y, Atis A, Mandiraci G**, Long-term effects of the levonorgestrel-releasing intrauterine system on serum lipids and the endometrium in breast cancer patients taking tamoxifen, *Climacteric* 11:252, 2008.
358. **Raudaskoski TH, Lahti EI, Kauppila AJ, Apaja-Sarkkinen MA, Laatikainen TJ**, Transdermal estrogen with a levonorgestrel-releasing intrauterine device for climacteric complaints: clinical and endometrial responses, *Am J Obstet Gynecol* 172:114, 1995.
359. **Suhonen S, Holmstrom T, Lahteenmaki P**, Three-year follow-up of the use of a levonorgestrel-releasing intrauterine system in hormone replacement therapy, *Acta Obstet Gynecol Scand* 76:145, 1997.
360. **Suvanto-Luukkonen E, Kauppila A**, The levonorgestrel intrauterine system in menopausal hormone replacement therapy: five-year experience, *Fertil Steril* 72:161, 1999.
361. **Varila E, Wahlstrom T, Rauramo I**, A 5-year follow-up study on the use of a levonorgestrel intrauterine system in women receiving hormone replacement therapy, *Fertil Steril* 76:969, 2001.
362. **Raudaskoski T, Tapanainen J, Tomas E, Luotola H, Pekonen F, Ronni-Sivula H, Timonen H, Riphagen F, Laatikainen T**, Intrauterine 10 microg and 20 microg levonorgestrel systems in postmenopausal women receiving oral oestrogen replacement therapy: clinical, endometrial and metabolic responses, *Br J Obstet Gynaecol* 109:136, 2002.
363. **Chan SS, Tam WH, Yeo W, Yu MM, Ng DP, Wong AW, Kwan WH, Yuen PM**, A randomised controlled trial of prophylactic levonorgestrel intrauterine system in tamoxifen-treated women, *Br J Obstet Gynaecol* 114:1510, 2007.
364. **Gardner FJ, Konje JC, Bell SC, Abrams KR, Brown LJ, Taylor DJ, Habiba M**, Prevention of tamoxifen induced endometrial polyps using a levonorgestrel releasing intrauterine system: long-term follow-up of a randomised control trial, *Gynecol Oncol* 114:452, 2009.
365. **Bahamondes L, Ribeiro-Huguet P, de Andrade KC, Leon-Martins O, Petta CA**, Levonorgestrel-releasing intrauterine system (Mirena) as a therapy for endometrial hyperplasia and carcinoma, *Acta Obstet Gynecol Scand* 82:580, 2003.
366. **Vereide AB, Kaino T, Sager G, Arnes M, Ørbo A**, Effect of levonorgestrel IUD and oral medroxyprogesterone acetate on glandular and stromal progesterone receptors (PRA and PRB), and estrogen receptors (ER-alpha and ER-beta) in human endometrial hyperplasia, *Gynecol Oncol* 101:214, 2006.
367. **Wildemeersch D, Pylser K, De Wever N, Dhont M**, Treatment of non atypical and atypical endometrial hyperplasia with a levonorgestrel-releasing intrauterine system: long-term follow-up, *Maturitas* 57:210, 2007.
368. **Wheeler DT, Bristow RE, Kurman RJ**, Histologic alterations in endometrial hyperplasia and well-differentiated carcinoma treated with progestins, *Am J Surg Pathol* 31:988, 2007.
369. **Varma R, Soneja H, Bhatia K, Ganesan R, Rollason T, Clark TJ, Gupta JK**, The effectiveness of a levonorgestrel-releasing intrauterine system (LNG-IUS) in the treatment of endometrial hyperplasia—a long-term follow-up study, *Eur J Obstet Gynecol Reprod Biol* 139:169, 2008.
370. **Haimovich S, Checa MA, Mancebo G, Fusté P, Carreras R**, Treatment of endometrial hyperplasia without atypia in peri- and postmenopausal women with a levonorgestrel intrauterine device, *Menopause* 15:1002, 2008.
371. **Bergman L, Beelen MLR, Gallee MPW, Hollema H, Benraadt J, van Leeuwen FE**; the

- Comprehensive Cancer Centres' ALERT Group**, Risk and prognosis of endometrial cancer after tamoxifen for breast cancer, *Lancet* 356:881, 2000.
372. **Guerrieri JP, Elkas JC, Nash JD**, Evaluating the endometrium in women on tamoxifen: a pilot study to compare a "gold standard" with an "old standard", *Menopause* 4:6, 1997.
373. **Lopez L, Fernandez YG, Rodriguez BR, Lopex FM, Delgado RC**, Value of progesterone test in screening for endometrial pathology in asymptomatic postmenopausal women receiving treatment with tamoxifen, *Menopause* 17:487, 2010.
374. **Fung MF, Reid A, Faught W, Le T, Chenier C**, et al., Prospective longitudinal study of ultrasound screening for endometrial abnormalities in women with breast cancer receiving tamoxifen, *Gynecol Oncol* 91:154, 2003.
375. **Develioglu OH, Omak M, Bilgin T, Esmer A, Tufekci M**, The endometrium in asymptomatic breast cancer patients on tamoxifen: value of transvaginal ultrasonography with saline infusion and Doppler flow, *Gynecol Oncol* 93:328, 2004.
376. **Goldstein SR**, Unusual ultrasonographic appearance of the uterus in patients receiving tamoxifen, *Am J Obstet Gynecol* 170:447, 1994.
377. **Ford MRW, Turner MJ, Wood C, Soutter WP**, Endometriosis developing during tamoxifen therapy, *Am J Obstet Gynecol* 158:1119, 1988.
378. **Hajjar LR, Kim W, Nolan GH, Turner S, Raju UR**, Intestinal and pelvic endometriosis presenting as a tumor and associated with tamoxifen therapy: report of a case, *Obstet Gynecol* 82:642, 1993.
379. **Rose PG, Alvarez B, MacLennan GT**, Exacerbation of endometriosis as a result of premenopausal tamoxifen exposure, *Am J Obstet Gynecol* 183:507, 2000.
380. **Cohen I, Altaras MM, Lew S, Tepper R, Beyth Y, Ben-Baruch G**, Ovarian endometrioid carcinoma and endometriosis developing in a post-menopausal breast cancer patient during tamoxifen therapy: a case report and review of the literature, *Gynecol Oncol* 55:443, 1994.
381. **Cohen I, Beyth Y, Shapira J, Tepper R, Fishman A, Cordoba M, Bernheim J, Yigael D, Altaras MM**, High frequency of adenomyosis in postmenopausal breast cancer patients treated with tamoxifen, *Gynecol Obstet Invest* 44:200, 1997.
382. **McCluggage WG, Bryson C, Lamki H, Boyle DD**, Benign, borderline, and malignant endometrioid neoplasia arising in endometriosis in association with tamoxifen therapy, *Int J Gynecol Pathol* 19:276, 2000.
383. **Okugawa K, Hirakawa T, Ogawa S, Kaku T, Nakano H**, Ovarian endometrioid adenocarcinoma arising from an endometriotic cyst in a postmenopausal woman under tamoxifen therapy for breast cancer: a case report, *Gynecol Oncol* 87:231, 2002.
384. **Zhao Y, Agarwal VR, Mendelson CR, Simpson ER**, Estrogen biosynthesis proximal to a breast tumor is stimulated by PGE2 via cyclic AMP, leading to activation of promoter II of the CYP19 (aromatase) gene, *Endocrinology* 137:5739, 1996.
385. **Bulun SE, Lin Z, Imir G, Amin S, Demura M, Yilmaz B, Martin R, Utsunomiya H, Thung S, Gurates B, Tamura M, Langoi D, Deb S**, Regulation of aromatase expression in estrogen-responsive breast and uterine disease: from bench to treatment, *Pharmacol Rev* 57:359, 2005.
386. **Terry MB, Gammon MD, Zhang FF, Tawfik H, Teitelbaum SL, Britton JA, Subbaramaiah K, Dannenberg AJ, Neugut AI**, Association of frequency and duration of aspirin use and hormone receptor status with breast cancer risk, *JAMA* 291:2433, 2004.
387. **Bundred NJ, Barnes NLP**, Potential use of COX-2-aromatase inhibitor combinations in breast cancer, *Br J Cancer* 93(Suppl 1):S10, 2005.
388. **Brueggemeier RW, Hackett JC, Diaz-Cruz ES**, Aromatase inhibitors in the treatment of breast cancer, *Endocr Rev* 26:331, 2005.
389. **Bonnetterre J, Thurlimann B, Robertson JF, Drzakowski M, Mauriac L, Koralewski P, Vergote I, Webster A, Steinberg M, von Euler M**, Anastrozole versus tamoxifen as first-line therapy for advanced breast cancer in 668 postmenopausal women: results of the Tamoxifen or Arimidex Randomized Group Efficacy and Tolerability Study, *J Clin Oncol* 18:3748, 2000.
390. **Nabholtz JM, Buzdar A, Pollak M, Harwin W, Burton G, Mangalik A, Steinberg M, Webster A, von**

- Euler M, Anastrozole is superior to tamoxifen as first-line therapy for advanced breast cancer in postmenopausal women: results of a North American multicenter randomized trial, *J Clin Oncol* 18:3758, 2000.
391. Mouridsen H, Gershanovich M, Sun Y, Perez-Carrion R, Boni C, Monnier A, Apffelstaedt J, et al., Phase III study of letrozole versus tamoxifen as first-line therapy of advanced breast cancer in postmenopausal women: analysis of survival and update of efficacy from the International Letrozole Breast Cancer Group, *J Clin Oncol* 21:2101, 2003.
392. Paridaens R, Dirix L, Lohrisch C, Beex L, Nooij M, Cameron D, Biganzoli L, Cufer T, Duchateau L, Hamilton A, Lobelle JP, Piccart M, Mature results of a randomized phase II multicenter study of exemestane versus tamoxifen as first-line hormone therapy for postmenopausal women with metastatic breast cancer, *Ann Oncol* 14:1391, 2003.
393. Baum M, Budzar AU, Cuzick J, Forbes J, Houghton JH, Klijn JG, Sahmoud T; The ATAC (Arimidex Tamoxifen Alone or in Combination) Trialists' Group, Anastrozole alone or in combination with tamoxifen versus tamoxifen alone for adjuvant treatment of postmenopausal women with early breast cancer: first results of the ATAC randomised trial, *Lancet* 359:2131, 2002.
394. Baum M, Buzdar A, Cuzick J, Forbes J, Houghton JH, Howell A, Sahmoud T, Anastrozole alone or in combination with tamoxifen versus tamoxifen alone for adjuvant treatment of postmenopausal women with early-stage breast cancer: results of the ATAC (Arimidex, Tamoxifen Alone or in Combination) trial efficacy and safety update analyses, *Cancer* 98:1802, 2003.
395. Arimidex, Tamoxifen, Alone or in Combination (ATAC) Trialists' Group; Forbes JF, Cuzick J, Buzdar A, Howell A, Tobias JS, Baum M, Effect of anastrozole and tamoxifen as adjuvant treatment for early-stage breast cancer: 100-month analysis of the ATAC trial, *Lancet Oncol* 9:45, 2008.
396. Duffy SR, Distler W, Howell A, Cuzick J, Baum M, A lower incidence of gynecologic adverse events and interventions with anastrozole than with tamoxifen in the ATAC trial, *Am J Obstet Gynecol* 200:80.e1, 2009.
397. Thurlimann B, Letrozole vs tamoxifen as adjuvant endocrine therapy for postmenopausal women with receptor positive breast cancer. BIG 1-98: a prospective randomized double-blind phase III study, [http://www.ibcsg.org/public/documents/pdf/divers/BIG\\_1098\\_StGallen\\_2005.pdf](http://www.ibcsg.org/public/documents/pdf/divers/BIG_1098_StGallen_2005.pdf), 2005.
398. The Breast International Group (BIG) I-98 Collaborative Group, A comparison of letrozole and tamoxifen in postmenopausal women with early breast cancer, *N Engl J Med* 353:2747, 2005.
399. Boccardo F, Rubagotti A, Puntoni M, Guglielmini P, Amoroso D, Fini A, Paladini G, Mesiti M, Romeo D, Rinaldini M, Scali S, Porpiglia M, Benedetto C, Restuccia N, Buzzi F, Frnachi R, Maddidda B, Distante V, Amadori D, Sismondi P, Switching to anastrozole versus continued tamoxifen treatment of early breast cancer: preliminary results of the Italian Tamoxifen anastrozole Trial, *J Clin Oncol* 23:5138, 2005.
400. Coombes RC, Hall E, Gibson LJ, Paridaens R, Jassem J, Delozier T, Jones SE, et al., A randomized trial of exemestane after two to three years of tamoxifen therapy in postmenopausal women with primary breast cancer, *N Engl J Med* 350:1081, 2004.
401. Coombes RC, Kilburn LS, Snowdon CF, Paridaens R, Coleman RE, Jones SE, Jassem J, et al.; Intergroup Exemestane Study, Survival and safety of exemestane versus tamoxifen after 2-3 years' tamoxifen treatment (Intergroup Exemestane Study): a randomised controlled trial, *Lancet* 369:559, 2007.
402. Rea D, Hasenburg A, Seynaeve C, Jones SE, Vannetzel J-M, Paridaens R, Markopoulos C, Hozumi Y, Putter H, Hille E, Asmar L, Urbanski R, van de Velde CH, Bartlett JMS, Smeets J, Kieback DG, Five years of exemestane as initial therapy compared to 5 years of tamoxifen followed by exemestane: the TEAM trial, a prospective, randomized, phase III trial in postmenopausal women with hormone-sensitive early breast cancer, San Antonio Breast Cancer Symposium, Abstract 11 December 9-13, 2009.
403. Derks MGM, Blok EJ, Seynaeve C, Nortier JWR, Kranenborg EM, et al., Adjuvant tamoxifen and exemestane in women with postmenopausal early breast cancer (TEAM): 10-year follow up of a multicenter, open-label, randomized, phase 3 trial, *Lancet Oncol* 18:1211, 2017.
404. Goss PE, Ingle JN, Martino S, Robert NJ, Muss HB, Piccart MJ, Castiglione M, et al., A randomized trial of letrozole in postmenopausal women after five years of tamoxifen therapy for early-stage breast cancer, *N Engl J Med* 349:1793, 2003.

405. **Ingle JN, Tu D, Pater JL, Muss HB, Martino S, Robert NJ, Piccart MJ**, et al., Intent-to-treat analysis of the placebo-controlled trial of letrozole for extended adjuvant therapy in early breast cancer: NCIC CTG MA.17, *Ann Oncol* 19:877, 2008.
406. **Winer EP, Hudis C, Burstein HJ, Wolff AC, Pritchard KI, Ingle JN, Chlebowski RT, Gelber R, Edge SB, Gralow J, Cobleigh MA, Mamounas EP, Goldstein LJ, Whelan TJ, Powles TJ, Bryant J, Perkins C, Perotti J, Braun S, Langer AS, Browman GP, Somerfield MR**, American Society of Clinical Oncology technology assessment on the use of aromatase inhibitors as adjuvant therapy for postmenopausal women with hormone receptor-positive breast cancer: status report 2004, *J Clin Oncol* 23:619, 2005.
407. **Goss PE, Ingle JN, Pater JL, Martino S, Robert NJ, Muss HB, Piccart MJ**, et al., Late extended adjuvant treatment with letrozole improves outcome in women with early-stage breast cancer who complete 5 years of tamoxifen, *J Clin Oncol* 26:1948, 2008.
408. **Smith IE, Dowsett M**, Aromatase inhibitors in breast cancer, *N Engl J Med* 348:2431, 2003.
409. **Eisner A, Falardeau J, Toomey MD, Vetto JT**, Retinal hemorrhages in anastrozole users, *Optom Vis Sci* 85:E301, 2008.
410. **Punglia RS, Kuntz KM, Winer EP, Weeks JC, Burstein HJ**, Optimizing adjuvant endocrine therapy in postmenopausal women with early-stage breast cancer: a decision analysis, *J Clin Oncol* 23:5178, 2005.
411. **The BIG1–98 Collaborative Group**, Letrozole therapy alone or in sequence with tamoxifen in women with breast cancer, *N Engl J Med* 361:766, 2009.
412. **National Comprehensive Cancer Network**, NCCN Clinical Practice Guidelines in Oncology, [http://www.nccn.org/professionals/physician\\_gls/f\\_guidelines.asp](http://www.nccn.org/professionals/physician_gls/f_guidelines.asp), 2018.
413. **Brufsky A, Bundred N, Coleman R, Lambert-Falls R, Mena R, Hadji P, Jin L, Schenk N, Ericson S, Perez EA; Z-FAST and ZO-FAST Study Groups**, Integrated analysis of zoledronic acid for prevention of aromatase inhibitor-associated bone loss in postmenopausal women with early breast cancer receiving adjuvant letrozole, *Oncologist* 13:503, 2008.
414. **Gnant M, Mlineritsch B, Schippinger W, Luschin-Ebengreuth G, Pörtlberger S, Menzel C, Jakesz R, Seifert M, Hubalek M, Bjelic-Radisic V, Samonigg H, Tausch C, Eidtmann H, Steger G, Kwasny W, Dubsy P, Fridrik M, Fitzal F, Stierer M, Rücklinger E, Greil R; for the ABCSG-12 Trial Investigators**, Endocrine therapy plus zoledronic acid in premenopausal breast cancer, *N Engl J Med* 360:679, 2009.
415. **Lester JE, Dodwell D, Purohit OP, Gutcher SA, Ellis SP, Thorpe R, Horsman JM, Brown JE, Hannon RA, Coleman RE**, Prevention of anastrozole-induced bone loss with monthly oral ibandronate during adjuvant aromatase inhibitor therapy for breast cancer, *Clin Cancer Res* 14:6336, 2008.
416. **Brufsky AM, Bosserman LD, Caradonna RR, Haley BB, Jones CM, Moore HC, Jin L, Warsi GM, Ericson SG, Perez EA**, Zoledronic acid effectively prevents aromatase inhibitor-associated bone loss in postmenopausal women with early breast cancer receiving adjuvant letrozole: Z-FAST study 36-month follow-up results, *Clin Breast Cancer* 9:77, 2009.
417. **Chlebowski RT, Chen Z, Cauley JA, Rodabough RJ, McTiernan A, Lane DS, Manson JE, Snetselaar L, Yasmeen S, O’Sullivan MJ, Stafford M, Hendrix SL, Wallace RB**, Oral bisphosphonate and breast cancer: prospective results from the Women’s Health Initiative (WHI), San Antonio Breast Cancer Symposium, Abstract 21, December 9–13, 2009.
418. **Hue TF, Cummings SR, Cauley JA, Bauer DC, Ensrud KE, Barrett-Connor E, Black DM**, Effect of bisphosphonate use on risk of postmenopausal breast cancer: results from the randomized clinical trials of alendronate and zoledronic acid, *JAMA Intern Med* 174:1550, 2014.
419. **Cuppone F, Bria E, Verma S, Pritchard KI, Gandhi S, Carlini P, Milella M, Nistico C, Terzoli E, Cognetti F, Giannarelli D**, Do adjuvant aromatase inhibitors increase the cardiovascular risk in postmenopausal women with early breast cancer? Meta-analysis of randomized trials, *Cancer* 112:260, 2008.
420. **Goldvase H, Barnes TA, Seruga B, Cescon DW, Ocaña A, Ribnikar D, Amir E**, Toxicity of extended adjuvant therapy with aromatase inhibitors in early breast cancer: a systemic review and meta-analysis, *J Natl Cancer Inst* 110, 2018.
421. **Jenkins VA, Ambroisine LM, Atkins L, Cuzick J, Howell A, Fallowfield LJ**, Effects of anastrozole on

cognitive performance in postmenopausal women: a randomised, double-blind chemoprevention trial (IBIS II), *Lancet Oncol* 9:953, 2008.

422. **Bender CM, Sereika SM, Brufsky AM, Ryan CM, Vogel VG, Rastogi P, Cohen SM, Casillo FE, Berga SL**, Memory impairments with adjuvant anastrozole versus tamoxifen in women with early-stage breast cancer, *Menopause* 14:995, 1997.
423. **Schilder CM, Seynaeve C, Beex LV, Boogerd W, Linn SC, Gundy CM, Huizenga HM, Nortier JW, van de Velde CJ, van Dam FS, Schagen SB**, Effects of tamoxifen and exemestane on cognitive functioning of postmenopausal patients with breast cancer: results from the neuropsychological side study of the Tamoxifen and Exemestane Adjuvant Multinational trial, *J Clin Oncol* 28(8):1294, 2010.
424. **Veronesi U, Maisonneuve P, Rotmensz N, Bonanni B, Boyle P, Viale G, Costa A, Sacchini V, Travaglini R, D’Aiuto G, Oliviero P, Lovison F, Gucciardo G, del Turco MR, Muraca MG, Pizzichetta MA, Conforti S, Decensi A; Italian Tamoxifen Study Group**, Tamoxifen for the prevention of breast cancer: late results of the Italian randomized tamoxifen prevention trial among women with hysterectomy, *J Natl Cancer Inst* 99:727, 2007.
425. **Powles TJ, Ashley S, Tidy A, Smith IE, Dowsett M**, Twenty-year follow-up of the Royal Marsden randomized, double-blinded tamoxifen breast cancer prevention trial, *J Natl Cancer Inst* 99:283, 2007.
426. **Cuzick J, Forbes JF, Sestak I, Cawthorn S, Hamed H, Holli K, Howell A; For the International Breast Cancer Intervention (IBIS) Investigators**, Long-term results of tamoxifen prophylaxis for breast cancer—96-month follow-up of the randomized IBIS-I trial, *J Natl Cancer Inst* 99:272, 2007.
427. **Gail MH, Brinton LA, Byar DP, Corle DK, Green SB, Shairer C, Mulvihill JJ**, Projecting individualized probabilities of developing breast cancer for white females who are being examined annually. *J Natl Cancer Inst* 81(24):1879, 1989.
428. **Cuzick J, Powles T, Veronesi U, Forbes J, Edwards R, Ashley S, Boyle P**, Overview of the main outcomes in breast-cancer prevention trials, *Lancet* 361:296, 2003.
429. **King M-C, Wieand S, Hale K, Lee M, Walsh TL, Owens K, Tait J, Ford L, Dunn BK, Costantino JP, Wickerham L, Wolmark N, Fisher B**, Tamoxifen and breast cancer incidence among women with inherited mutations in BRCA1 and BRCA2. National Surgical Adjuvant Breast and Bowel Project (NSABP-P1) Breast Cancer Prevention Trial, *JAMA* 286:2251, 2001.
430. **Gail MH, Costantino JP, Bryant J, Croyle R, Freedman L, Helzlsouer K, Vogel V**, Weighing the risks and benefits of tamoxifen treatment for preventing breast cancer, *J Natl Cancer Inst* 91:1829, 1999.
431. **Freedman AN, Graubard BI, Rao SR, McCaskill-Stevens W, Ballard-Barbash R, Gail MH**, Estimates of the number of US women who could benefit from tamoxifen for breast cancer chemoprevention, *J Natl Cancer Inst* 95:526, 2003.
432. **Chlebowski RT, Col N, Winer EP, Collyar DE, Cummings SR, Vogel III VG, Burstein JH, Eisen A, Lipkus I, Pfister DG; American Society of Clinical Oncology Breast Cancer Technology Assessment Working Group**, American Society of Clinical Oncology technology assessment of pharmacologic interventions for breast cancer risk reduction including tamoxifen, raloxifene, and aromatase inhibition, *J Clin Oncol* 20:3328, 2002.
433. **Cauley JA, Norton L, Lippman ME, Eckert S, Krueger KA, Purdie DW, Farrerons J, Karasik A, Mellstrom D, Ng KW, Stepan JL, Powles TJ, Morrow M, Costa A, Silfen SL, Walls EL, Schmitt H, Muchmore DB, Jordan VC**, Continued breast cancer risk reduction in postmenopausal women treated with raloxifene: 4-year results from the MORE trial, *Breast Cancer Res Treat* 65:125, 2001.
434. **Martino S, Cauley JA, Barrett-Connor E, Powles TJ, Mershon J, Disch D, Secrest RJ, Cummings SR; for the CORE Investigators**, Continuing outcomes relevant to Evista: breast cancer incidence in postmenopausal osteoporotic women in a randomized trial of raloxifene, *J Natl Cancer Inst* 96:1651, 2004.
435. **Vogel VG, Costantino JP, Wickerham DL, Cronin WM, Cecchini RS, Atkins JN, Bevers TB, Fehrenbacher L, Pajon ERJ, Wade JL III, Robidoux A, Margolese RG, James J, Lippman SM, Runowicz CD, Ganz PA, Reis SE, McCaskill-Stevens W, Ford LG, Jordan VC, Wolmark N; National Surgical Adjuvant Breast and Bowel Project (NSABP)**, Effects of tamoxifen vs raloxifene on the risk of developing invasive breast cancer and other disease outcomes: the NSABP Study of Tamoxifen and Raloxifene



(STAR) P-2 trial, JAMA 295:2727, 2006.

436. **Siris ES, Harris ST, Eastell R, Zanchetta JR, Goemaere S, Diez-Perez A, Stock JL, Song J, Qu Y, Kulkarni PM, Siddhanti SR, Wong M, Cummings SR;** for the **Continuing Outcomes Relevant to Evista (CORE) Investigators**, Skeletal effects of raloxifene after 8 years: results from the Continuing Outcomes Relevant to Evista (CORE) Study, *J Bone Miner Res* 20:1514, 2005.
437. **Goss PE, Ingle JN, Ales-Martinez JE, Cheung AM, Chlebowski RT,** et al., Exemestane for breast-cancer prevention in postmenopausal women, *N Engl J Med* 364:2381, 2011.
438. **Dunn BK, Ryan A,** Phase 3 trials of aromatase inhibitors for breast cancer prevention: following in the path of the selective estrogen receptor modulators, *Ann N Y Acad Sci* 1155:141, 2009.
439. **Cigler T, Tu D, Yaffe MJ, Findlay B, Verma S, Johnston D, Richardson H, Hu H, Qi S, Goss PE,** A randomized, placebo-controlled trial (NCIC CTG MAP1) examining the effects of letrozole on mammographic breast density and other end organs in postmenopausal women, *Breast Cancer Res Treat* 120(2):427, 2010.
440. **Bardia A, Novotny PJ, Sloan JA, Barton D, Loprinzi C,** Efficacy of nonestrogenic hot flash therapies among women stratified by breast cancer history and tamoxifen use: a pooled analysis, *Menopause* 16:477, 2009.
441. **Stearns V, Johnson MD, Raae JM, Morocho A, Novielli A, Bhargava P, Hayes DF, Desta Z, Flockhart DA,** Active tamoxifen metabolite plasma concentrations after coadministration of tamoxifen and the selective serotonin reuptake inhibitor paroxetine, *J Natl Cancer Inst* 95:1758, 2003.
442. **Jin Y, Desta Z, Stearns V, Ward B, Ho H, Lee KH, Skaar T, Storniolo AM, Li L, Araba A, Blanchard R, Nguyen A, Ullmer L, Hayden J, Lemier S, Weinsilboum RM, Rae JM, Hayes DF, Flockhart DA,** CYP2D6 genotype, antidepressant use, and tamoxifen metabolism during adjuvant breast cancer treatment, *J Natl Cancer Inst* 97:30, 2005.
443. **Kelly CM, Juurlink DN, Gomes T, Duong-Hua M, Pritchard KI, Austin PC, Paszat LF,** Risk of death due to breast cancer in women treated with selective serotonin reuptake inhibitor antidepressants and tamoxifen, *San Antonio Breast Cancer Symposium, Abstract 2049*, December 9–13, 2009.
444. **Hindle WH,** Breast cancer: adaptation of fine-needle aspiration to office practice, *Clin Obstet Gynecol* 45:761, 2002.
445. **Donegan WL,** Evaluation of a palpable breast mass, *N Engl J Med* 327:937, 1992.
446. **Yaffe MJ, Mainprize JG, Jong RA,** Technical developments in mammography, *Health Phys* 95:599, 2008.
447. **Wertheimer MD, Costanza ME, Dodson TF, D’Orsi C, Pastides H, Zapka JG,** Increasing the effort toward breast cancer detection, *JAMA* 255:1311, 1986.
448. **Thomas DB, Gao DL, Self SG, Allison CJ, Tao Y, Mahloch J, Ray R, Qin Q, Presley R, Porter P,** Randomized trial of breast self-examination in Shanghai: methodology and preliminary results, *J Natl Cancer Inst* 89:355, 1997.
449. **Barton MB, Harris R, Fletcher SW,** Does this patient have breast cancer? The screening clinical breast examination: should it be done? How? *JAMA* 282:1270, 1999.
450. **Humphrey LL, Helfand M, Chan BK, Wolf SH,** Breast cancer screening: a summary of the evidence for the U.S. Preventive Services Task Force, *Ann Intern Med* 137:347, 2002.
451. **Tabar L, Yen M-F, Vitak B, Chen HT, Smith RA, Duffy SW,** Mammography service screening and mortality in breast cancer patients: 20-year follow-up before and after introduction of screening, *Lancet* 361:1405, 2003.
452. **Nelson HD, Fu R, Cantor A, Pappas M, Daeges M, Humphrey L,** Effectiveness of breast cancer screening: systematic review and meta-analysis to update the 2009 U.S. Preventive Services Task Force recommendation. *Ann Intern Med* 164(4):244, 2016.
453. **Seidman H, Gelb SK, Silverberg E, LaVerda N, Lubera JA,** Survival experience in the breast cancer detection demonstration project, *CA Cancer J Clin* 37:258, 1987.
454. **Stacey-Clear A, McCarthy KA, Hall DA, Pile-Spellman E, White G, Hulka G, Whitman GJ, Mahoney E, Kopans DB,** Breast cancer survival among women under age 50: is mammography detrimental?, *Lancet* 340:991, 1992.
455. **Bjurstam N, Björneld L, Duffy SW, Smith TC, Cahlin E, Eriksson O, Hafström L-O, Lingaas H,**

- Mattsson J, Persson S, Rudenstam C-M, Söderbergh JS; The Gothenburg Breast Screening Trial,** First results on mortality, incidence, and mode of detection for women ages 39–49 years at randomization, *Cancer* 80:2091, 1997.
456. **Bjurstam N, Björnelid L, Warwick J, Sala ES, Duffy SW, Nyström L, Walker N, Cahlin E, Eriksoon O, Hafström LO, Lingaas H, Mattsson J, Persson S, Rudenstam CM, Salander H, Säve-Söderbergh J, Wahlin T,** The Gothenburg breast screening trial, *Cancer* 97:2387, 2003.
457. **Smart CR, Hendrick RE, Rutledge JH III, Smith RA,** Benefit of mammography screening in women ages 40–49 years: current evidence from randomized controlled trials, *Cancer* 75:1619, 1995.
458. **Berry DA,** Benefits and risks of screening mammography for women in their forties: a statistical appraisal, *J Natl Cancer Inst* 90:431, 1998.
459. **Curpen BN, Sickles EA, Sollito RA, Ominsky SH, Galvin HB, Frankel SD,** The comparative value of mammographic screening for women 40–49 years old versus women 50–64 years old, *Am J Roentgenol* 164:1099, 1995.
460. **Kerlikowske K, Grady D, Barclay J, Sickles EA, Ernster V,** Effect of age, breast density, and family history on the sensitivity of first screening mammography, *JAMA* 276:33, 1996.
461. **Kerlikowske K, Grady D, Barclay J, Sickles E, Ernster V,** Likelihood ratios for modern screening mammography: risk of breast cancer based on age and mammographic interpretation, *JAMA* 276:39, 1996.
462. Report of the **Organizing Committee and Collaborators, Falun Meeting,** Breast cancer screening with mammography in women aged 40–49 years, *Int J Cancer* 68:693, 1996.
463. **Moss SM, Cuckle H, Evans A, Johns L, Waller M, Bobrow L; Trial Management Group,** Effect of mammographic screening from age 40 years on breast cancer mortality at 10 years' follow-up: a randomised controlled trial, *Lancet* 368:2053, 2006.
464. **Hermansen C, Poulsen HS, Jensen J, Langfeldt B, Steenskov V, Frederiksen P, Jensen OM,** Diagnostic reliability of combined physical examination, mammography, and fine-needle puncture (“triple-test”) in breast tumors: a prospective study, *Cancer* 60:1866, 1987.
465. **Kaufman Z, Shpitz B, Shapiro M, Roma R, Lew S, Dinbar A,** Triple approach in the diagnosis of dominant breast masses: combined physical examination, mammography, and fine-needle aspiration, *J Surg Oncol* 56:254, 1994.
466. **Vetto J, Pommier R, Schmidt W, Wachtel M, Du Bois P, Jones M, Thurmond A,** Use of the “triple test” for palpable breast lesions yields high diagnostic accuracy and cost savings, *Am J Surg* 169:519, 1995.
467. **Morris KT, Pommier RF, Morris A, Schmidt WA, Beagle G, Alexander PW, Toth-Fejel S, Schmidt J, Vetto JT,** Usefulness of the triple test score for palpable breast masses, *Arch Surg* 136:1008, 2001.
468. **Feig SA,** Mammographic screening of women aged 40–49 years: benefit, risk, and cost considerations, *Cancer* 76:2097, 1995.
469. **Lindfors K, Rosenquist C,** The cost-effectiveness of mammographic screening strategies, *JAMA* 274:881, 1995.
470. **Mandelblatt J, Saha S, Teutsch S, Hoerger T, Siu AL, Atkins D, Klein J, Helfand M; Cost Work Group of the U.S. Preventive Services Task Force,** The cost-effectiveness of screening mammography beyond age 65 years: a systematic review for the U.S. Preventive Services Task Force, *Ann Intern Med* 139:835, 2003.
471. **Mandelblatt JS, Wheat ME, Monane M, Moshief RD, Hollenberg JP, Tang J,** Breast cancer screening for elderly women with and without comorbid conditions: a decision analysis model, *Ann Intern Med* 116:722, 1992.
472. **Randolph WM, Goodwin JS, Mahnken JD, Freeman JL,** Regular mammography use is associated with elimination of age-related disparities in size and stage of breast cancer at diagnosis, *Ann Intern Med* 137:783, 2002.
473. **Pisano ED, Gatsonis C, Hendrick E, Yaffe M, Baum JK, Acharyya S, Conant EF, Fajardo LL, Bassett L, D’Orsi C, Jong R, Rebner M; Digital Mammographic Imaging Screening Trial (DMIST) Investigators Group,** Diagnostic performance of digital versus film mammography for breast-cancer screening, *N Engl J Med* 353:1773, 2005.

474. **Pisano ED, Hendrick RE, Yaffe MJ, Baum JK, Acharyya S, Cormack JB, Hanna LA, Conant EF, Fajardo LL, Bassett LW, D'Orsi C, Jong RA, Rebner M, Tosteson AN, Gatsonis CA; DMIST Investigators Group**, Diagnostic accuracy of digital versus film mammography: exploratory analysis of selected population subgroups in DMIST, *Radiology* 246:376, 2008.
475. **Berg WA, Blume JD, Cormack JB, Mendelson EB, Lehrer D, Böhm-Vélez M, Pisano ED, Jong RA, Evans WP, Morton MJ, Mahoney MC, Larsen LH, Barr RG, Farria DM, Marques HS, Boparai K; for the ACRIN 6666 Investigators**, Combined screening with ultrasound and mammography vs mammography alone in women at elevated risk of breast cancer, *JAMA* 299:2151, 2008.
476. **Corsetti V, Ferrari A, Ghirardi M, Bergonzini R, Bellarosa S, Angelina O, Bani C, Ciotto S**, Role of ultrasonography in detecting mammographically occult breast carcinoma in women with dense breasts, *Radiol Med* 111:440, 2006.
477. **Warner E, Plewes DB, Hill KA, Causer PA, Zubovits JT, Jong RA, Cutrara MR, DeBoer G, Yaffe MJ, Messner SJ, Meschino WS, Piron CA, Narod SA**, Surveillance of BRCA1 and BRCA2 mutation carriers with magnetic resonance imaging, ultrasound, mammography, and clinical breast examination, *JAMA* 292:1317, 2004.
478. **Lehman CD, Isaacs C, Schnall MD, Pisano ED, Ascher SM, Weatherall PT, Bluemke DA, Bowen DJ, Marcom PK, Armstrong DK, Domchek SM, Tomlinson G, Skates SJ, Gatsonis C**, Cancer yield of mammography, MR, and US in high-risk women: prospective multi-institution breast cancer screening study, *Radiology* 244:281, 2007.
479. **Warner E, Messersmith H, Causer P, Eisen A, Shumak R, Plewes D**, Systematic review: using magnetic resonance imaging to screen women at high risk for breast cancer, *Ann Intern Med* 148:671, 2008.
480. **Kuhl CK, Schrading S, Bieling HB, Wardelmann E, Leutner CC, Koenig R, Kuhn W, Schild HH**, MRI for diagnosis of pure ductal carcinoma in situ: a prospective observational study, *Lancet* 370:485, 2007.

# Menopause Transition and Menopause Hormone Therapy

# AN OVERVIEW

---

Throughout recorded history, multiple physical and mental conditions have been attributed to the menopause. Although medical writers often wrote colorfully in the past, unfortunately they were also less than accurate, unencumbered by scientific information and data.

A good example of the stereotypical, inaccurate thinking promulgated over the years is the following written in 1887<sup>1</sup>:

The ovaries, after long years of service, have not the ability of retiring in graceful old age, but become irritated, transmit their irritation to the abdominal ganglia, which in turn transmit the irritation to the brain, producing disturbances in the cerebral tissue exhibiting themselves in extreme nervousness or in an outburst of actual insanity.

The belief that behavioral disturbances are related to manifestations of the female reproductive system is an ancient one that has persisted to contemporary times. This belief regarding the menopause is not totally illogical; there is reason to associate the middle years of life with negative experiences. The events that come to mind are impressive: onset of a major illness or disability (and even death) in a spouse, relative, or friend; retirement from employment; financial insecurity; the need to provide care for very old parents and relatives; and separation from children. Thus, it is not surprising that a middle-aged event, the menopause, shares in this negative outlook.

The scientific study of all aspects of menstruation has been hampered by the overpowering influence of social and cultural beliefs and traditions. Problems arising from life events have often been erroneously attributed to the menopause. But data, especially more reliable community-based longitudinal data, now establish that the increase in most symptoms and problems in middle-aged women reflects social and personal circumstances, not the endocrine events of the menopause.<sup>2,3,4,5,6,7,8,9,10,11</sup> The variability in menopausal reactions makes the cross-sectional study design particularly unsuitable. Longitudinal studies are better for documenting what is normal and the variations around normal.

The Massachusetts Women's Health Study, a large and comprehensive prospective, longitudinal study of middle-aged women, provides a powerful argument that the menopause is not and should not be viewed as a negative experience by the vast majority of women.<sup>3,12</sup> The cessation of menses was perceived by these women (as have the women in other longitudinal studies) as having almost no impact on subsequent physical and mental health. This was reflected by women expressing either positive or

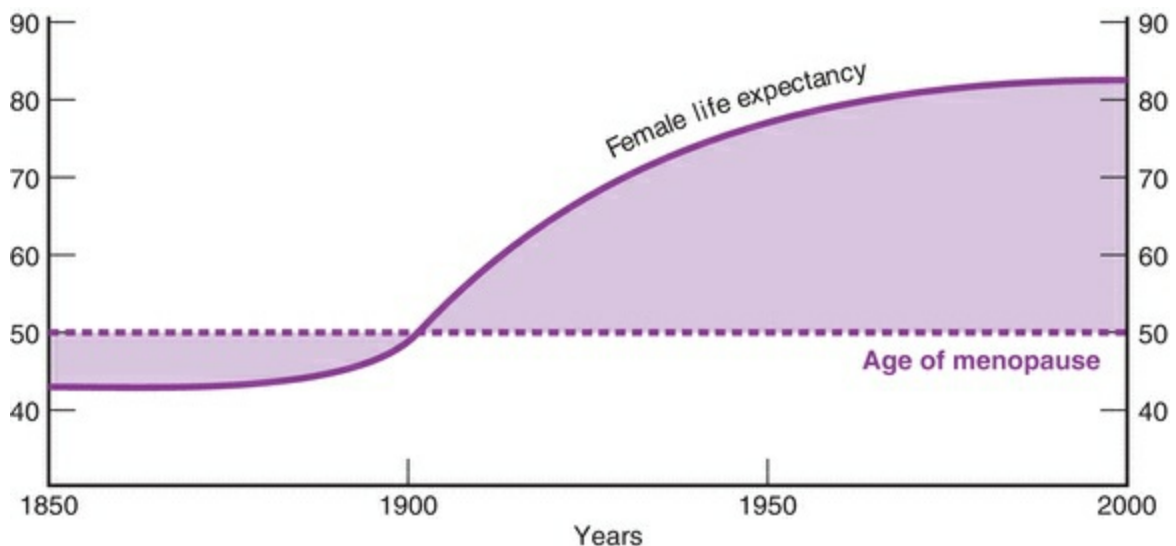
neutral feelings about menopause. An exception was the group of women who experienced surgical menopause, but there is good reason to believe that the reasons for the surgical procedure were more important than the cessation of menses.

Changes in menstrual function are not symbols of some ominous “change.” There are good physiologic reasons for changing menstrual function, and understanding the physiology will do much to reinforce a healthy, normal attitude. Attitude and expectations about the menopause are very important. Women who have been frequent users of health services and who expect to have difficulty do experience greater symptoms and higher levels of depression.<sup>4,8,9</sup> The symptoms that women report are related to many variables within their lives, and the hormonal change at menopause cannot be held responsible for the common psychosocial and lifestyle problems we all experience. It is important to stress the normalcy of this physiologic event. Menopausal women do not suffer from a disease (specifically a hormone deficiency disease), and postmenopausal hormone therapy should be viewed as specific treatment for symptoms in the short term and preventive pharmacology in the long term.

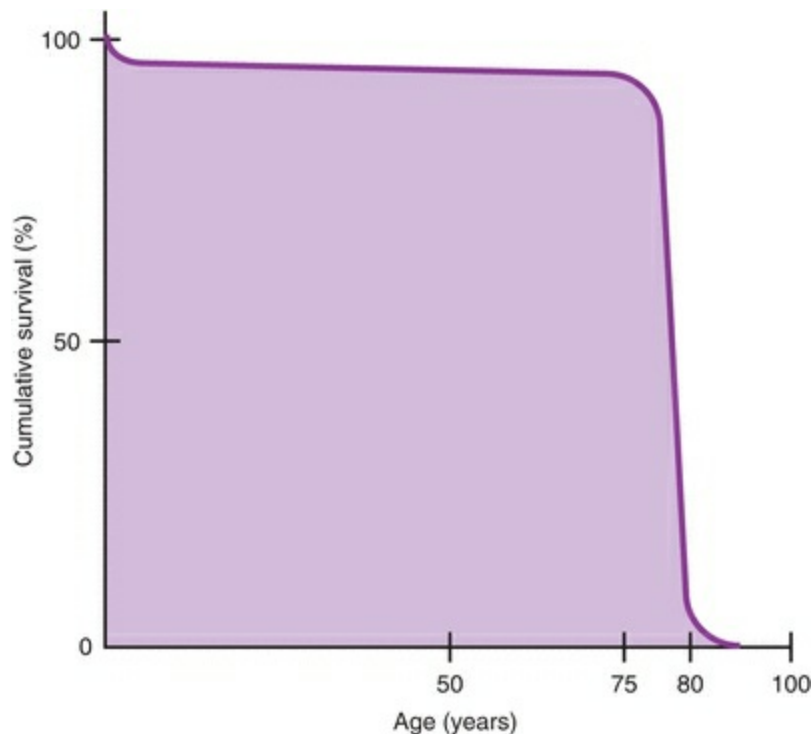
It can be further argued that physicians have had a biased (negative) point of view, because the majority of women, being healthy and happy, do not seek contact with physicians.<sup>13,14</sup> It is vital, therefore, that clinicians not only are familiar with the facts relative to the menopause but also have an appropriate attitude and philosophy regarding this period of life. Medical intervention at this point of life should be regarded as an opportunity to provide and reinforce a program of preventive health care. The issues of preventive health care for women are familiar ones. They include family planning, cessation of smoking, control of body weight and alcohol consumption, prevention of cardiovascular disease and osteoporosis, maintenance of mental well-being (including sexuality), cancer screening, and treatment of urologic problems.

# GROWTH OF THE OLDER POPULATION

We are experiencing a relatively new phenomenon: we can expect to become old. We are on the verge of becoming a rectangular society. This is a society in which nearly all individuals survive to advanced age. In 1,000 b.c., life expectancy was only 18 years. By 100 b.c., the time of Julius Caesar, it had reached 25 years. In 1900, in the United States, life expectancy still had reached only 49 years (**Figure 17.1**). In 2005, the average life expectancy was 80.7 years for women and 75.4 for men.<sup>15</sup> Today, once you reach 65, if you are a man, you can expect to reach 83 and if you are a woman, age 85.<sup>16</sup> We can anticipate that eventually, about two-thirds of the population will survive to 85 or more, and more than 90% will live past age 65—this would be the nearly perfect rectangular society (**Figure 17.2**).<sup>17,18</sup> Currently, Sweden and Switzerland are closest to this demographic composition.



After **Cope E.** Physical changes associated with the post-menopausal years, In: Campbell S, ed. *The Management of the Menopause & Post-Menopausal Years*, University Park Press, Baltimore, 1976, p. 33.

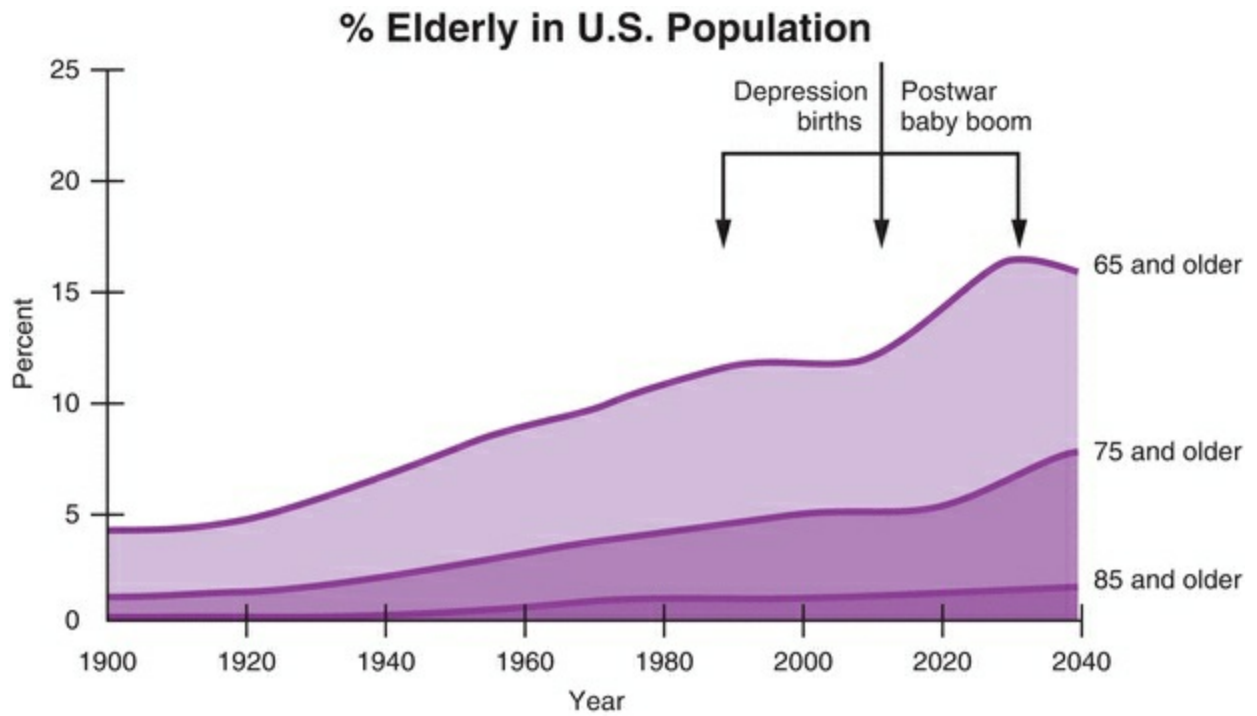


After Fries JF, Crapo LM, Vitality and Aging, W.H. Freeman and Co., San Francisco, 1981.<sup>29</sup>

A good general definition of elderly is 65 and older, although it is not until age 75 that a significant proportion of older people show the characteristic decline and problems. Today, the elderly population is the largest contributor to illness and human need in the United States. There are more old people (with their greater needs) than ever before.<sup>19</sup> In 1900, there were approximately 3 million Americans 65 and older (about 4% of the total population), and in 2000, there were 35 million (about 12% of the total population). By 2030, the elderly population in the United States will reach about 70 million, and about one in five Americans will be elderly.<sup>19</sup> The world's elderly population will be more than double from 1998 to 2025, rising from 264 million in 2009 to 416 million in 2050.<sup>20</sup> Population aging must be added to population growth as very important social problems.

Two modern phenomena have influenced the rate of change. The first was the post-World War II baby boom (1946–1964) that temporarily postponed the aging of the population, but now is causing a faster aging of the general population. The second major influence has been the decline in old-age mortality. Our success in postponing death has increased the upper segment of the demographic contour (**Figure 17.3**). By 2050, the current developed nations will be rectangular societies. China, by 2050, will contain more people over age 65 than the number of people of all ages currently living in the United States (**Table 17.1**).





**FIGURE 17.3**

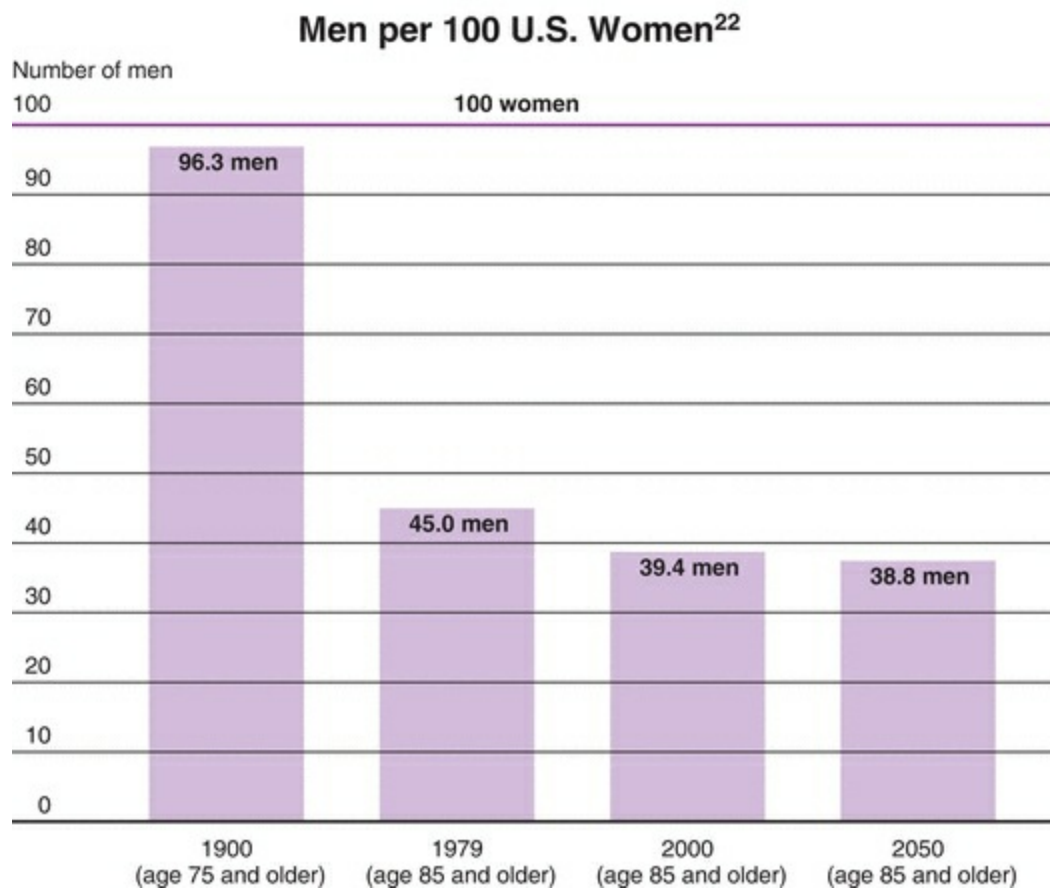
**TABLE 17.1 Current World Population Figures**

	<b>Births</b>	<b>Deaths</b>	<b>Growth</b>
<b>Year</b>	140,773,000	51,315,000	89,458,000
<b>Month</b>	11,731,080	4,276,250	7,454,834
<b>Week</b>	2,707,173	140,589	245,090
<b>Hour</b>	16,070	5,858	10,212
<b>Minute</b>	268	96	170
<b>Second</b>	4.5	1.6	2.8

From McDevitt TM, Stanecki KA, Way PO , Report WP/98, World Population Profile: 1998, Washington, DC: US Census Bureau; 1999.<sup>21</sup>

This is a worldwide development, not limited to affluent societies.<sup>21</sup> The population of the earth will continue to grow until the year 2100 or 2150, when it is expected to stabilize at approximately 11 billion. After 2020, all of this growth will occur in developing countries.<sup>20</sup> In 2000, the poorest countries (located in Africa and Asia) accounted for 87% of the world's population. In 1950, only 40% of people 60 and older lived in developing countries. By 2050, about 80% will live in those countries, as fertility in the developing regions is expected to drop from 2.73 children per woman in 2005–2010 to 2.05 by 2050.<sup>20</sup>

In aging populations, a gender differential in survival is recognized. In 1900, men over age 65 in the United States outnumbered women by 102 to 100. Now, there are only 70 men for every 100 women over age 65.<sup>22</sup> By age 85, only 39 men are alive for every 100 women. Nearly 90% of white American women can expect to live to age 70. Vital statistics data indicate that this gender difference is similar in both the black and white populations in the United States (**Figure 17.4**).<sup>23</sup> Approximately 55% of girls, but only 35% of boys, live long enough to celebrate their 85th birthday.<sup>24</sup> One in 5,600 individuals can expect to live to be 100.<sup>22</sup>



**FIGURE 17.4**

The 10 leading causes of death in the United States in 2016 were as follows<sup>16</sup>:

- 1. Heart disease**
- 2. Cancer**
- 3. Unintentional injuries**
- 4. Chronic lower respiratory diseases**
- 5. Stroke**
- 6. Alzheimer disease**
- 7. Diabetes mellitus**
- 8. Influenza and pneumonia**
- 9. Kidney diseases**
- 10. Suicides**

Men and women reach old age with different prospects for older age, a sex differential that (it can be argued) is due in significant part to the sex hormone–induced differences in the cholesterol-lipoprotein profile and other cardiovascular factors and thus the greater incidence of atherosclerosis and earlier death in men. From a public health point

of view, the greatest impact on the sex differential in mortality would be gained by concentrating on lifestyle changes designed to diminish atherosclerosis: low-cholesterol diet, no smoking, optimal body weight, and active exercise. The death rate is higher for men at all ages, and therefore women are overrepresented in aging populations (Table 17.2). Coronary heart disease (CHD) accounts for 40% of the mortality difference between men and women. Another one-third is from lung cancer, emphysema, cirrhosis, accidents, and suicides. It is interesting to note that in our society, the mortality difference between men and women is largely a difference in lifestyle. Smoking, drinking, coronary-prone behavior, and accidents account for most of the higher male mortality rate over age 65. It has been estimated that perhaps two-thirds of the difference have been due to cigarettes alone. But we should emphasize that this is due to a greater prevalence of smoking in men. Women whose smoking patterns are similar to those of men have a similar increased risk of morbidity and mortality.<sup>25</sup>

## **TABLE 17.2 The Older US Female Population**

Age	1990	2000	2010	2020
55–64	10.8 mill. (8.6%)	12.1 mill. (9.0%)	17.1 mill. (12.1%)	19.3 mill. (12.9%)
65–74	10.1 (8.1%)	9.8 (7.3%)	11.0 (7.8%)	15.6 (10.4%)
≥75	7.8 (6.2%)	9.3 (7.0%)	9.8 (6.9%)	11.0 (7.3%)
<b>Total</b>	28.7	31.2	37.9	45.9

From McDevitt TM, Stanecki KA, Way PO, Report WP/98, World Population Profile: 1998, Washington, DC: US Census Bureau; 1999.<sup>21</sup>

The mortality sex difference has been decreasing since 1979. The U.S. Census Bureau projects that the difference in life expectancy between men and women will increase until the year 2050 and then level off. In 2050, life expectancy for women will be 82 years and for men, 76.7 years.<sup>26</sup> There will be 33.4 million women 65 years and older, compared with 22.1 million men.

In addition to the growing numbers of elderly people, the older population itself is getting older. For example, in 1984, the 65–74 age group in the United States was over 7 times larger than in 1900, but the 75–84 group was 11 times larger, and the 85 and older group was 21 times larger. In the 1990s, the population 85 years and older increased by 38%.<sup>22</sup> The most rapid increase is expected between 2010 and 2030 when the post–World War II baby boom generation will be age 65 and over. In the next century, the only age groups in the United States expected to experience significant growth will be those past age 55. In this older age group, women will outnumber men by 2.6 to 1. By the year 2040, in the United States, there will be 8 million to 13 million people 85 years of age or older; the estimate varies according to pessimistic to optimistic projections regarding disease prevention and treatment.

Unmarried women will be an increasing proportion of the elderly. Elderly women are more likely to be widowed (59%) than elderly men (22%).<sup>27</sup> Half of men 85 and older live with their wives, but only 10% of elderly women live with their husbands.<sup>28</sup> Because the unmarried tend to be more disadvantaged, there will be a need for more

services for this segment of the elderly population. Older unmarried people are more vulnerable, demonstrating higher mortality rates and lower life satisfaction.

# The Rectangularization of Life

The life span is the biologic limit to life, the maximal obtainable age by a member of a species. The general impression is that the human life span is increasing. Actually, life span is fixed, and it is a biologic constant for each species.<sup>29</sup> In fact, differences in species' life spans argue in favor of a species-specific genetic basis for longevity. If life span were not fixed, it would mean an unlimited increase of our elderly. But a correct analysis of survival reveals that death converges at the same maximal age; what has changed is life expectancy—the number of years of life expected from birth. Life expectancy cannot exceed the life span, but it can closely approximate it. Thus, the number of old people will eventually hit a fixed limit, but the percentage of a typical life spent in the older years will increase (**Figure 17.2**).

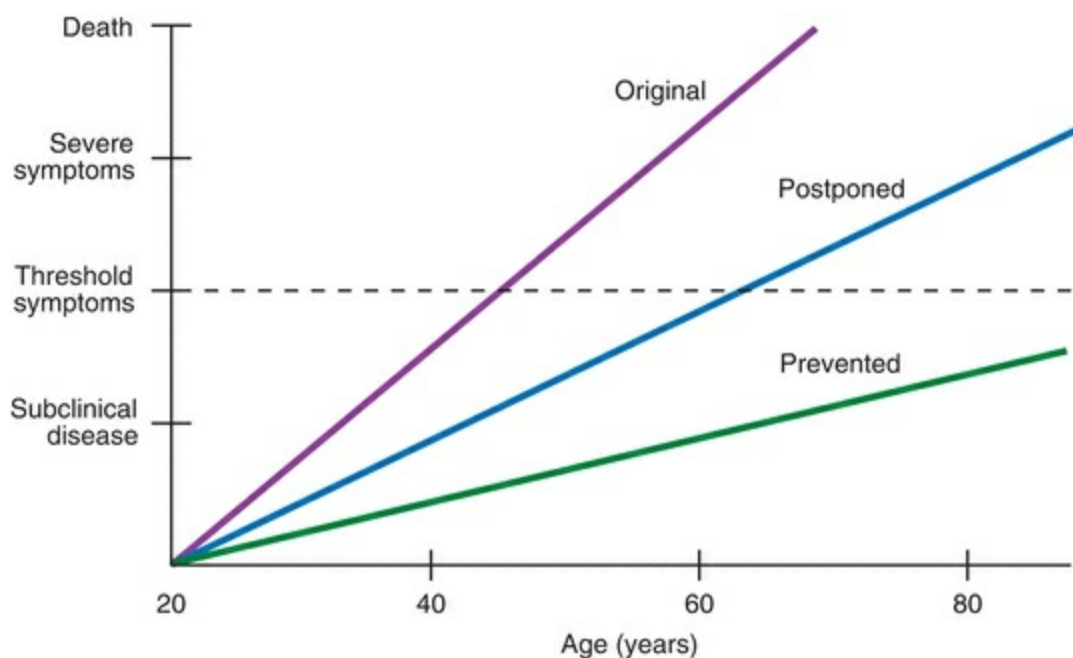
Our society has almost eliminated premature death. Diseases of the heart and the circulation, and cancers are now the leading causes of death. The reason for this is not an increase or an epidemic; it is a result of our success in virtually eliminating infectious diseases. Now, the major determinant is chronic disease, affected by genetics, lifestyle, the environment, and aging itself. Even if cancer, diabetes, and all circulatory diseases were totally eliminated, life expectancy would not exceed 90 years.<sup>17</sup>

J.F. Fries described three eras in health and disease.<sup>30</sup> The first era existed until sometime in the early 1900s and was characterized by acute infectious diseases. The second era, highlighted by cardiovascular diseases and cancer, is now beginning to fade into the third era, marked by problems of advancing age (fading eyesight and hearing, impaired memory and cognitive function, decreased strength and reserve). Much of our medical approach is still based on the first era (find the disease and cure it), and now we have conditions that require a combination of medical, psychological, and social approaches. Our focus has been on age-dependent, fatal chronic diseases. The new challenge is with the nonfatal, age-dependent conditions, such as Alzheimer disease, osteoarthritis, osteoporosis, obesity, and incontinence. It can be argued that health programs in the future should be evaluated by their impact on years free of disability, rather than on mortality.

# The Concept of the Compression of Morbidity

Chronic illnesses are incremental in nature. The best health strategy is to change the slope, the rate at which illness develops, thus postponing the clinical illness and, if it is postponed long enough, effectively preventing it. There has been a profound change in public consciousness toward disease. Disease is increasingly seen as something not necessarily best treated by medication or surgery but by prevention.

Preventing illness was expressed by J.F. Fries as the **compression of morbidity**.<sup>29,31</sup> We would live relatively healthy lives and compress our illnesses into a short period of time just before death. Is this change really possible? A good affirmative example is the decrease in atherosclerosis in the United States. Reasons include changes in the use of saturated fat, more effective detection and treatment of hypertension, increased exercise, and decreased smoking (**Figure 17.5**).



After Fries JF, Crapo LM, Vitality and Aging, W.H. Freeman and Co., San Francisco, 1981.<sup>29</sup>

Physician smokers have declined from a high of 79% to a small minority.<sup>32</sup> It is interesting, and amusing, to note that the greatest decrease has been among pulmonary surgeons, not surprising, while the least decrease has been among proctologists. From the mid-1970s to the early 1990s, smoking among physicians in the United States declined from 18.8% to 3.3%. Unfortunately, that still amounted to approximately 18,000 physicians who smoke. Approximately 35% of people in the United States who have not obtained a high school diploma are smokers, but only 12% of those with higher



education are smoking and only 5.7% of those with graduate degrees. Currently, approximately 17.5% of men and 13.5% of women are smokers.<sup>16</sup> Cigarette smoking among high school students peaked in 1997 and then declined to the current level of 15.5%.<sup>16</sup> In addition, 14% of high school students smoke cigars and 8% use chewing tobacco. The use of chewing tobacco, pipe smoking, and cigars contributes significantly to morbidity and mortality. Tobacco, therefore, continues to be the single most preventable cause of premature illness and death in the United States. It is important to note that smoking has a greater adverse effect on women compared with men.<sup>33</sup> Women who smoke only 1–4 cigarettes per day have a 2.5-fold increased risk of fatal CHD.<sup>34</sup>

Quitting smoking after decades of smoking is beneficial, and the beneficial effects are seen as early as 1 month after quitting.<sup>35</sup> In the Nurses' Health Study, 61% of the excess risk of CHD mortality and 42% of stroke mortality were eliminated within 5 years after quitting smoking.<sup>36</sup> The improvement in respiratory disease mortality is slower, and a small increased risk of lung cancer mortality persists even after 30 years. However, by 20 years after cessation, all the excess risk of vascular mortality and death due to respiratory diseases other than lung cancer reached the level of a never smoker. Even older patients who already have coronary artery disease have improved survival if they quit smoking.<sup>37</sup> No matter how old you are, if you continue to smoke, you have an increased relative risk of death. But no matter how old you are, if you quit smoking, your risk of death decreases. Nevertheless, the risk of lung cancer remains elevated even in long-term ex-smokers.<sup>38</sup>

Since 1970, the death rate from CHD has declined approximately 50% in the United States. Between 1973 and 1987, in the United States, cardiovascular mortality declined in nearly every age group. In the combined age groups up to 54 years, cardiovascular mortality decreased to 42% and in people 55–84 years old, 33%.<sup>33</sup> Despite our progress, we must continue to exert preventive efforts on the risk factors associated with cardiovascular disease, especially obesity, hypertension, and lack of physical activity.

The effort to improve the quality of life has an important value to society; it will decrease the average number of years that people are disabled, which is a major health and social problem of society. Most significantly, this is a major financial challenge for health care systems and social programs. With evolution toward a rectangular society, the ratio of beneficiaries to taxpayers grows rapidly, jeopardizing the financial support for health and social programs. Compression of morbidity is at least one attractive solution to this problem.

# MENOPAUSE AS AN OPPORTUNITY

---

Menopause is a normal phase of life, much like puberty; it should not be viewed as abnormal. For many women, it is a welcome change—no further menses or premenstrual syndrome (PMS) and no need for contraception/concern for conceiving. Clinicians who interact with women at the time of the menopause have a wonderful opportunity and, therefore, a significant obligation. Medical intervention at this point of life offers women years of benefit from preventive health care. This phase of life represents an opportunity that should be seized.

**While not underrating the importance of good health habits among the young, we would argue that the impact of teaching preventive care is more observable and more tangible at middle age. The prospects of limited mortality and the morbidity of chronic diseases are viewed with belief, understanding, and appreciation during these older years. The chance of illness is higher, but the impact of changes in lifestyle is greater.**

# Stages of Reproductive Aging: Reproductive Years to Perimenopause (Older Terminology) or Menopausal Transition (Newer Term) to Menopause

In 2001, the Stages of Reproductive Aging Workshop (STRAW) standardized the nomenclature for the stages of the menopausal transition.<sup>39</sup> Prior to this workshop, there was no accepted system for defining the stages of reproductive aging leading up to menopause. In 2010, at a follow-up workshop (“STRAW + 10”), the criterion was updated to reflect advances in changes in the hypothalamic-pituitary function occurring throughout reproductive aging.<sup>40</sup> The STRAW staging system divides female life span into three broad phases: reproductive phase, menopausal transition phase, and postmenopause phase. Each of the three phases is divided into stages based on information obtained through clinical (menstrual cycle pattern, symptoms) and investigative (serum levels of follicle-stimulating hormone [FSH] and antimüllerian hormone [AMH] and ultrasound-based ovarian antral follicle count [AFC]) data. The menopausal transition is a finite period of physiologic changes that eventually culminates in reproductive senescence. This phase of life can be associated with unique challenges that can have significant effects on population’s well-being and on quality of life.<sup>39</sup> A woman is said to have reached menopause if she has remained amenorrheic for a consecutive of 12-month interval and demonstrates biochemical evidence of hypergonadotropic (elevated FSH and luteinizing hormone [LH] levels) hypogonadism (low estradiol levels). The last or final menstrual period (FMP) is identified as stage “0” marking a watershed between reproductive and postreproductive periods of life. The reproductive phase itself is broken down into five stages (early [−5], peak [−4], and late [−3]). The menopause transition phase is broken down into two stages (early [−2] and late [−1]). The postmenopause phase is also divided into two stages (early [+1] and late [+2]).<sup>40</sup> **The FMP thus serves as the reference point for interpretation of the rest of the stages across the three specified phases of reproductive aging (Figure 17.6).**

Stages	-5	-4	-3b	-3a	-2	01	0	+1	+2a	+2b	
<b>Phase</b>	<b>Reproductive</b>				<b>Transition</b>		<b>FMP</b>	<b>Post Menopause</b>			
<b>Clinical profile</b>	Fertile	Fertility problems for some	<ul style="list-style-type: none"> <li>Fertility problems</li> <li>Menstrual irregularity</li> <li>Occasional VMS</li> </ul>		<ul style="list-style-type: none"> <li>Fertility problems</li> <li>Menstrual irregularity</li> <li>VMS are common</li> </ul>			<ul style="list-style-type: none"> <li>VMS are common</li> <li>Declining bone density</li> </ul>		<ul style="list-style-type: none"> <li>Improving VMS in many</li> <li>Worsening GUSM symptoms</li> <li>Worsening risk for osteoporosis, cardiovascular disease</li> </ul>	
<b>Biochemical finding</b>	<ul style="list-style-type: none"> <li>Normal AMH &amp; inhibin</li> <li>Low FSH</li> </ul>	<ul style="list-style-type: none"> <li>Normal AMH &amp; inhibin</li> <li>Low FSH</li> </ul>	<ul style="list-style-type: none"> <li>Declining AMH</li> <li>Declining inhibin</li> <li>Rising FSH</li> </ul>		<ul style="list-style-type: none"> <li>Low or undetectable AMH &amp; inhibin levels</li> <li>High FSH</li> </ul>			<ul style="list-style-type: none"> <li>High FSH</li> <li>AMH &amp; inhibin undetectable</li> </ul>		<ul style="list-style-type: none"> <li>Stable FSH</li> <li>AMH &amp; inhibin undetectable</li> </ul>	<ul style="list-style-type: none"> <li>Slight decline in FSH</li> <li>AMH &amp; inhibin undetectable</li> </ul>
<b>Ultrasound findings</b>	Adequate AFC >>8		Decline in AFC		Few antral follicles			Occasional antral follicle			

AMH: Antimüllerian hormone  
 FSH: Follicle stimulating hormone  
 AFC (Antral follicle count)  
 AMS: Vasomotor symptoms  
 GUSM: Genitourinary Syndrome of Menopause  
 FMP: Final menstrual period

Adapted and modified from Harlow SD, Gass M, Hall JE, Lobo R, Maki P, Rebar RW, Sherman S, Sluss PM, de Villiers TJ; STRAW + 10 Collaborative Group, Executive summary of the Stages of Reproductive Aging Workshop + 10: addressing the unfinished agenda of staging reproductive aging, *Climacteric* 15(2):105, 2012.<sup>40</sup>

## Late Reproductive Stage (STRAW Stage -3)

A decline in fecundability is apparent as the earliest hallmark of transition followed by a spectrum of clinically apparent phenomenon, such as changes in menstrual cycle pattern. As covert endocrinologic changes set in well before noticeable and clinically apparent features (such as changes in the menstrual cycle), STRAW +10 recommended that the late reproductive stage be divided into substages -3b and -3a. In stage -3b, the menstrual cycles are relatively unchanged, the early follicular phase serum levels of FSH are relatively low and in normal premenopausal range, whereas AMH and AFC (and likely inhibin B) are low.<sup>41</sup> In stage -3a, menstrual cycles become shorter and early follicular FSH increases, while AMH, AFC, and inhibin B are low.<sup>41</sup>

## Early Menopausal Transition (STRAW Stage -2)

This stage is characterized by increasing irregularity of the menstrual cycle length. This irregularity is defined as a recurrence of 7-day difference in cycle length over 10 cycles. This stage is also characterized by variable elevations in early follicular phase FSH levels, with persistently low AMH levels and low AFC.<sup>41</sup>

## Late Menopausal Transition (STRAW Stage -1)

This stage is characterized by missed menses with periods of amenorrhea lasting greater than or equal to 60 days. Menstrual cycles are increasingly irregular in length, with variability in reproductive hormonal levels and high incidence of anovulation. FSH levels are usually elevated in the menopausal range, although at times can be in the premenopausal range with concomitant high estradiol levels. An FSH level of greater than 25 IU/L is commonly seen in this late transition stage. This stage lasts 1–3 years and is when vasomotor symptoms such as hot flashes begin to occur.<sup>41</sup>

## **Early Postmenopause (STRAW Stage 1, Substages +1a, +1b, +1c)**

In the early postmenopause, FSH levels continue to rise, while estradiol levels continue to decline until 2 years after the FMP, after which these hormone levels stabilize. The substages +1a and +1b in early menopause last 1 year each and culminate once fluctuations in FSH levels stabilize. Stage +1a marks the completion of the 12-month interval required to define the FMP. This substage also marks the end of the perimenopause (i.e., the time near menopause, which starts at stage –2 and ends 12 months following the FMP).<sup>41</sup> Stage +1b includes the continued changes in levels of FSH and estradiol; vasomotor symptoms are most common in stage +1a and +1b. In stage +1c, the elevated FSH and low estradiol levels become the new normal. This substage lasts for up to 3–6 years. As such, the early postmenopause stage spans a total of 5–8 years.<sup>41</sup>

## **Late Postmenopause (Stage +2)**

At this stage, reproductive hormone levels are essentially plateaued and stable. While the burden of vasomotor symptoms eases off for many, physical symptoms attributable to lack of estrogen, such as vaginal dryness and urogenital symptoms, become more prominent at this stage. Interestingly, FSH levels may decline further with age, although more research is needed to confirm this observation.<sup>41</sup>

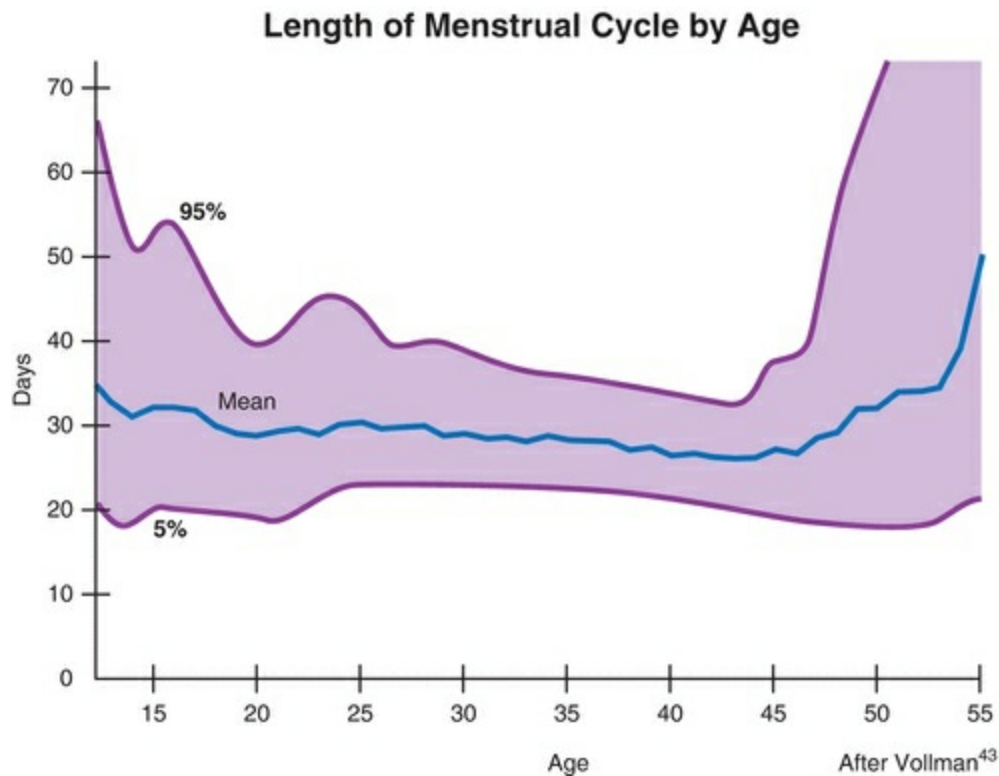
# THE MENOPAUSAL TRANSITION

---

There is only one marker, menstrual irregularity, that can be used to objectively define and establish what is called the menopausal transition. This irregularity will be perceived by patients as skipped menstrual periods or longer durations (about 40–60 days) between periods.<sup>42</sup> There is no universal pattern; each woman will perceive a change that is her own individual characteristic alteration.

The **menopause** is that point in time when permanent cessation of menstruation occurs following the loss of ovarian activity. Menopause is derived from the Greek words men (month) and pausis (cessation). **Climacteric**, an older, more general, and less precise term, indicates the period of time when a woman passes from the reproductive stage of life through the menopausal transition and the menopause to the postmenopausal years. Climacteric is from the Greek word for ladder. **Perimenopause** is the newer term that includes the years prior to the FMP during which menstrual cycles progress from a regular ovulatory and predictable pattern to irregular and increasingly anovulatory cycles to eventual cessation of menses.<sup>41</sup>

Menstrual cycle length is determined by the rate and quality of follicular growth and development, and it is normal for the cycle to vary in individual women. Informative data come from two seminal longitudinal studies (with very similar results): the study of Vollman of more than 30,000 cycles recorded by 650 women and the study of Treloar of more than 25,000 woman-years in a little over 2,700 women.<sup>43,44</sup> The earlier observations of Vollman and Treloar that documented a normal evolution in length and variation in menstrual cycles. were subsequently confirmed by Cole et al.<sup>45</sup> (**Figure 17.7**).



**FIGURE 17.7**

Following onset of menarche, there is approximately a 2- to 3-year period of relatively long menstrual cycles at first, and then, there is increasing regularity as cycles shorten to reach the usual reproductive age pattern. In the 40s, cycle length may begin to alter again. The highest incidence of anovulatory cycles is under age 20 and over age 40.<sup>46,47</sup> At age 25, over 40% of cycles are between 25 and 28 days in length; from 25 to 35, over 60% are between 25 and 28 days. The perfect 28-day cycle is indeed the most common mode, but it totaled only 12.4% of cycles described by Völlman whereby overall, approximately 15% of reproductive age cycles are 28 days in length. Only 0.5% of women experience a cycle less than 21 days long and only 0.9% a cycle greater than 35 days.<sup>48</sup> Most women have cycles that last from 24 to 35 days, but at least 20% of women experience irregular cycles.<sup>49</sup>

When women are in their 40s, anovulation becomes more prevalent, and prior to anovulation, menstrual cycle length increases, beginning 2–8 years before menopause.<sup>44</sup> Cycles greater than 40 days in length are quite prevalent in the year before menopause.<sup>50</sup> In an Australian longitudinal study, when cycle length exceeded 42 days, menopause predictably followed within 1 or 2 years.<sup>51</sup> This period of longer cycles commonly precedes menopause no matter the age when menses cease, whether menopause is early or late.<sup>52</sup> The duration of the follicular phase is the major determinant of cycle

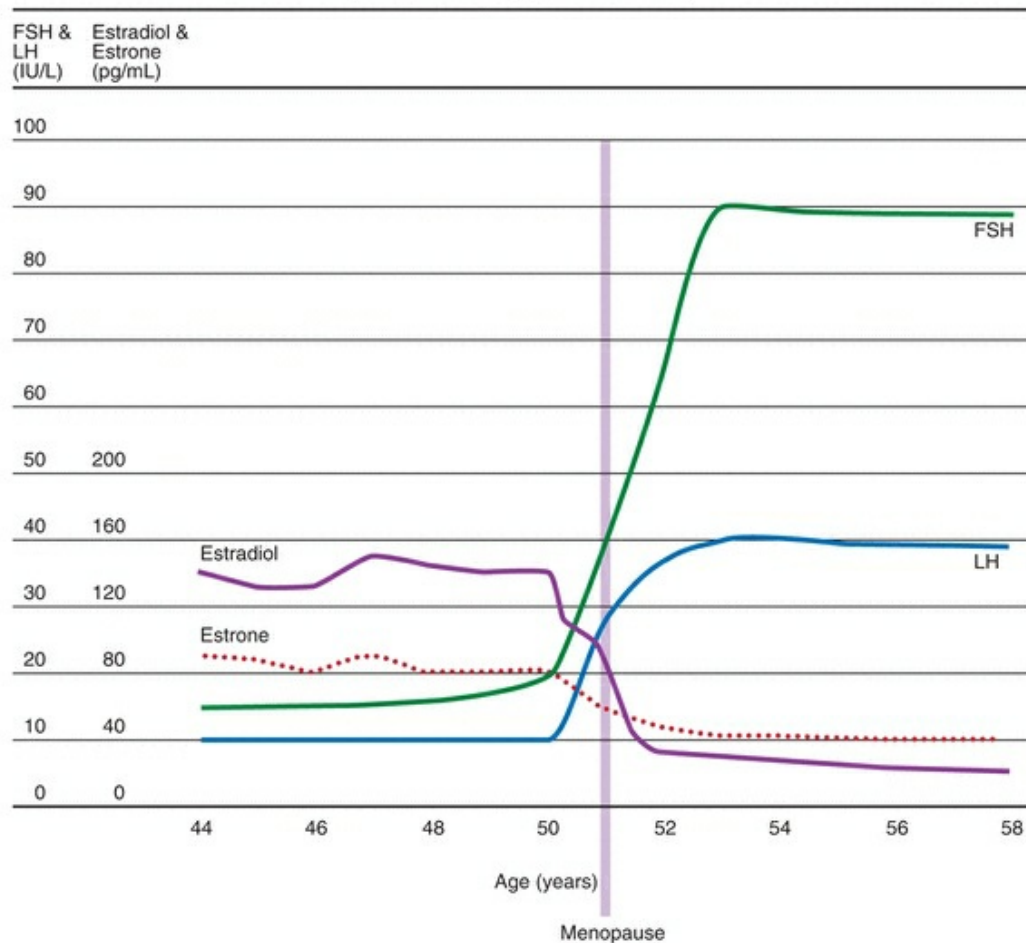
length.<sup>53,54</sup> This menstrual cycle change prior to menopause is marked by elevated FSH levels and decreased levels of inhibin but normal levels of LH and slightly elevated levels of estradiol.<sup>55,56,57,58,59,60,61</sup> **Importantly, even irregular cycles with long intervals (>50–60 days) can be ovulatory, as many as 25%, and although fecundity is markedly reduced, late perimenopausal women remain at risk for unplanned pregnancy.**<sup>62</sup>

**In the average woman, a decline in fertility begins around age 37–38, and menopause follows approximately 13 years later (average age 51).** However, in epidemiologic studies, approximately 10% of women in the general population become menopausal by the age of 45,<sup>63,64</sup> while the exact mechanisms underlying spontaneous early menopause (before age 45) remain unclear, and are not generalizable, it is probable that some women are born with a smaller than normal ovarian follicular pool that gets functionally depleted at an earlier age. Menopause occurs when the number of remaining ovarian follicles falls below a critical threshold, about 1,000, regardless of age.

Contrary to older belief (based on a seminal report by Sherman et al. in 1976<sup>53</sup>), **estradiol levels do not gradually wane in the years before the menopause, but remain in the normal range, and even be slightly elevated, until about 1 year before follicular growth and development cease.** Sherman et al. conducted a small cross-sectional study wherein serum samples were collected over a single menstrual cycle from eight women, aged 46–56, for the study of reproductive hormones. More recent longitudinal studies of women as they pass through the menopausal transition reveal that estrogen levels do not begin a major decline until about a year before menopause (**Figure 17.8**).<sup>59,65,66</sup> Indeed, women experiencing the menopausal transition actually have higher overall estrogen levels, a response that is logically explained by an increased ovarian follicular reaction in response to the higher circulating FSH levels during this period.<sup>67</sup> Variability in estrogen levels is characteristic of the menopausal transition, with greater hormonal variability observed in menstrual cycles that display greater irregularity.<sup>68</sup>



**Reproductive Hormone Profile From Menopause Transition (or Perimenopause) Into Menopause**  
(mean circulating hormone levels)



**FIGURE 17.8**

As noted, most women experience a 2- to 8-year period of time prior to the FMP when the occurrence of anovulation becomes common.<sup>44</sup> During this time, ovarian follicles continue their rate of loss until eventually the reservoir is finally depleted.<sup>69,70</sup> In a study of human ovaries, the loss that began when the total number of follicles reached approximately 25,000, usually at age 37–38, correlated with a subtle but real increase in FSH and decrease in inhibin levels.<sup>71</sup> Aging-related decline in the quantity of ovarian follicles is directly related to the rise in FSH levels that occurs with advancing age; this rise in FSH results from reduced secretion of inhibin, a granulosa cell product that exerts an important negative feedback influence over FSH secretion by the pituitary gland. It is possible that both inhibin A and inhibin B may be involved, because luteal phase levels of inhibin A and follicular phase levels of inhibin B decrease with aging and antedate the rise in FSH.<sup>72,73,74</sup> A careful study in Australia, however, indicated that the increase in FSH was correlated only with a decrease in inhibin B, and in response to elevated FSH, estradiol levels increased slightly.<sup>65</sup>

Decrease in inhibin production by the follicular granulosa cells could reflect either a shrinking number of ovarian follicles, or a reduced functional capacity of the older follicles, or both.<sup>75</sup> **The observation that preovulatory follicular fluid inhibin concentrations are similar in young and older cycling women suggests that the number of remaining follicles is the most important factor.**<sup>76</sup>

In the late reproductive stage, driven by higher FSH levels, the process of follicular recruitment and development gets accelerated with resulting shortening of the follicular phase. This accelerated pace of follicular development in the late reproductive stage is reflected in higher estradiol levels being attained earlier in the follicular phase, suggesting that higher FSH levels stimulate more rapid follicular development.<sup>77</sup> **Careful studies indicated that the earlier acute rise in estradiol levels results from advanced follicular development at the beginning of the cycle and earlier selection of the dominant follicle.**<sup>78,79</sup> Follicular phase and overall cycle length reach their nadir at approximately age 42. Over the subsequent 8–10 years preceding the FMP, average cycle length and variability steadily increase as ovulations become less regular and less frequent.<sup>43</sup> The aging-related changes in the endocrine characteristics of the menstrual cycle that result from progressive follicular depletion correlate with a measurable decrease in the ovarian volume and in the number of antral follicles observed by transvaginal ultrasonography during the early follicular phase.<sup>80,81,82,83,84,85,86</sup>

The inverse and tight relationship between FSH and inhibin indicates that inhibin is a sensitive marker of ovarian follicular competence and, in turn, that FSH measurement is a reflection of inhibin.<sup>56,57</sup> The decrease in inhibin secretion by the ovarian follicles begins early (around age 35), but accelerates after 40 years of age, and parallels the decline in fecundity that occurs with aging (as discussed in [Chapter 25](#)). **Furthermore, the ineffective ability to achieve suppression of gonadotropins with menopausal hormone therapy is a consequence of the loss of inhibin, and for this reason, FSH levels cannot be used to titrate estrogen dosage in menopausal women on hormone therapy regimens.**

The Michigan Bone Health and Metabolism Study is a longitudinal assessment of the menopausal transition in a cohort of 629 women initiated in 1992–1993. The initial rise in FSH in these women was modest until 7 years prior to menopause and then accelerated with an even greater increase in the 2 years before menopause, finally reaching a plateau about a year after menopause.<sup>87</sup> The major decrease in estradiol levels began about 2 years before menopause.<sup>88</sup> Declining levels of inhibin B and AMH reached a low to nondetectable point about 5 years before menopause.<sup>89</sup> Although the inhibin B and AMH results are in agreement with other reports, an exactness of the timing is limited by the fact that the blood samples were obtained from only 50 women

in the study. Furthermore, Depmann et al. also demonstrated that while AMH can help in predicting impending menopause as it relates to aging, this predictability is far from being robust.<sup>90</sup> Nevertheless, the Michigan study confirms the validity of AMH as a marker for residual ovarian follicles, a concept that is referred to as ovarian reserve. Unlike inhibin B, AMH is not a participant in the feedback relationship between the ovary and the pituitary gonadotropins, rather AMH, a product of the granulosa cells, and reflects the number of residual follicles awaiting FSH stimulation.<sup>91</sup> **The variability in these hormone measurements from individual to individual, however, precludes the practical use of these biomarkers to predict with accuracy the future date of menopause.**<sup>90</sup>

The transition or perimenopausal years are a time period during which postmenopausal levels of FSH (>20 IU/L) can be seen despite continued menstrual bleeding, while LH levels still remain in the normal range. Occasionally, corpus luteum formation and function occur, and the perimenopausal woman is not safely beyond the risk of an unplanned and unexpected pregnancy until persistently elevated levels of both FSH (25 IU/L) and LH (30 IU/L) can be demonstrated.<sup>58</sup> However, even under these circumstances, fluctuations can occur, with a transient period of ovarian failure (reflected in amenorrhea, elevated gonadotropins, and low estradiol levels) followed by spontaneous resumption of ovarian function for a brief period.<sup>57</sup> **Because variability is the rule, it would be wise to recommend the use of contraception until the postmenopausal stage is definitely established.** According to the Guinness Book of World Records, a woman from the United Kingdom holds the modern record for the oldest spontaneous pregnancy, conceiving when 59 years old via cesarean section. **Several months of amenorrhea together with a persistently elevated FSH level of 40 IU/L or more are reliable signals that menopause is either near or has already happened.**<sup>92</sup>

In the longitudinal Massachusetts Women's Health Study, women who reported the onset of menstrual irregularity were considered to be in the perimenopausal period of life.<sup>93</sup> The median age for the onset of this period was 47.5 years. **Only 10% of women ceased menstruating abruptly with no period of prolonged irregularity.** The menopausal transition from reproductive to postreproductive status was, for most women, approximately 4 years in duration. In the study by Treloar, the average age for entry into the menopausal transition was 45.1, and the age range that included 95% of the women was 39–51.<sup>63</sup> The mean duration of the menopausal transition was 5.0 years, with a range of 2–8 years (Table 17.3).

## **TABLE 17.3 The Menopause Transition (or**

## Perimenopause)

Average age of onset—46

---

Age of onset for 95% of women—39–51

---

Average duration—5 y

---

Duration for 95% of women—2–8 y

---

Data from **Treloar AE, Boynton RE, Borghild GB, Brown BW**, Variation of the human menstrual cycle through reproductive life, *Int J Fertil* 12:77, 1967<sup>44</sup>; **Treloar AE**, Menstrual cyclicity and the pre-menopause, *Maturitas* 3:249, 1981<sup>63</sup>; **McKinlay SM, Brambilla DJ, Posner JG**, The normal menopause transition, *Maturitas* 14:103, 1992.<sup>93</sup>

# Preventive Health Screening of Healthy Perimenopausal Women

The most important contribution a clinician can provide to the perimenopausal woman is the awareness and the knowledge that is required to allow aging women to make timely lifestyle and indicated therapeutic choices. This early educational process will help to build a solid relationship with patients, a relationship they will want to continue as they age. The following recommendations are derived from our own clinical experience:

- Provide reassurance that reproductive aging is a normal phenomenon and menopause is not a disorder.
- Provide guidance and education to facilitate a patient's decision-making.
- Provide time and an appropriate location for sensitive and uninterrupted discussions.
- Use educational materials, especially handouts, but also explain them using your own words.
- Involve family members during counseling and educational visits.
- Be accessible. Consider designating a member of your staff as the menopause resource person. Encourage phone calls and emails.
- Be involved in community and hospital educational programs for the public.
- Use an effective, well-trained counselor for patients who need in-depth help in coping with life's trials and tribulations.

Preventive intervention during the perimenopausal years has three major goals. The overall objective is to demystify reproductive aging and ensure that phases of menopause transition and postmenopause are approached as physiology and not pathology. The overarching goal is to optimize mental, physical, and social well-being. A specific goal is to detect as early as possible any of the major chronic diseases, including hypertension, heart disease, diabetes mellitus, and cancer, as well as impairments of vision, hearing, and teeth. Finally, the clinician should help symptomatic perimenopausal women to smoothly traverse the menopausal period of life. Preventive health care and management of the later reproductive years give clinicians an excellent opportunity to function as a woman's primary care provider.

## Key Points

- Regardless of chronological age, women should undergo annual medical

evaluations that should include a thorough medical history as well as physical examination.

- Annual visits should include assessment of vitals (blood pressure and pulse), body weight and BMI (body mass index), breast and pelvic examinations, and screening for sexually transmitted infections when appropriate. Thyroid function (TSH) should be assessed in the 40's and annually beginning at age 60 (as hypothyroidism, discussed in [Chapter 20](#), increases with aging and is more common in women).
- Annual screening mammography should begin at age 40 (discussed in [Chapter 16](#)).
- At each visit, appropriate testing is scheduled for specific chronic conditions (including abnormal lipids), indicated immunizations are provided, and counseling covers changing nutritional needs; physical activities; injury prevention; occupational, sexual, marital, and parental problems; urinary function; and use of tobacco, alcohol, and drugs. Stool hemocult testing should be performed annually after age 50.
- For low risk individuals without a family history of colon cancer, screening colonoscopy is recommended starting at age 50, and then every 10 years through age 75.

# Timing of Natural Menopause

Designating the average age of menopause has been somewhat difficult. Based on cross-sectional studies, the median age was estimated to be somewhere between 50 and 52.<sup>94</sup> These studies relied on retrospective memories and the subjective vagaries of the individual being interviewed. Until recently, studies with longitudinal follow-up to observe women and record their experiences as they pass through menopause were hampered by relatively small numbers. The Massachusetts Women's Health Study provides us with data from 2,570 women.<sup>93</sup>

The median age for menopause in the Massachusetts Study was 51.3 years. Only current smoking could be identified as a cause of earlier menopause, a shift of approximately 1.5 years. Those factors that did not affect the age of menopause in this study included the use of oral contraception, socioeconomic status, and marital status. Keep in mind that a **median** age of menopause means that only half the women have reached menopause at this age. In the classic longitudinal study by Treloar, the **average** age of menopause was 50.7 years, and the range that included 95% of the women was 44–56 years.<sup>95</sup> In a survey in the Netherlands, the average age of menopause was 50.2, and in an Italian longitudinal study, it was 50.9 years.<sup>64,96</sup>

The Study of Women's Health Across the Nation (SWAN) is an ongoing, national study, recording the health of American women as they pass through the perimenopausal transition (<http://www.edc.gsph.pitt.edu/swan/>). The study began in 1994 in seven research centers and enrolled 3,302 participants with five racial/ethnic groups and a variety of backgrounds for an initial cross-sectional survey. In 1996, these women began a longitudinal, follow-up study with extensive data collection occurring annually.

In the SWAN study, the median age of menopause was 51.4, with an earlier onset associated with current smoking, lower education, and lower socioeconomic status, whereas a later age was associated with parity and prior use of oral contraceptives.<sup>97</sup> In contrast, a Dutch study concluded that prior use of oral contraceptives was associated with earlier (<1 year) menopause.<sup>98</sup> About 1% of women have been reported to experience menopause before the age of 40.<sup>99</sup> The SWAN study reported a similar percentage of 1.1%, with a slightly higher rate in Black and Hispanic women and a lower rate of 0.5% in Chinese women and 0.1% in Japanese women.<sup>100</sup> Hispanic women experienced menopause about 6 months earlier compared with other ethnic groups, whereas Japanese women were about 3 months later.

Two large cohorts of European women reported average ages of menopause in various countries that centered around age 51 years, slightly higher in Northern Europe and slightly lower in Southern Europe.<sup>101</sup> Some countries, like India, report an average

age of menopause as much as 5 years earlier.<sup>102</sup> In epidemiologic studies, approximately 10% of women in the general population become menopausal by the age of 45.<sup>63,64</sup> Pedigree analysis has revealed that the genetic features of early menopause (age 40–45) and premature ovarian insufficiency (POI) or failure (cessation of ovarian function occurring at an age <40) are similar and suggest a dominant pattern of inheritance through maternal or paternal relatives.<sup>103,104</sup> There are two studies indicating that daughters of mothers with an early menopause (before age 46) also have an early menopause, with up to 15% of women having a first-degree relative with early menopause.<sup>105,106,107,108</sup>

There is sufficient evidence to suggest that chronically undernourished women and vegetarians may experience an earlier menopause.<sup>105,109</sup> Because of the contribution of body fat to estrogen production, thinner women experience a slightly earlier menopause.<sup>110</sup> Frequent consumption of alcohol is associated with a later menopause.<sup>106</sup> This is consistent with the reports that women who consume alcohol have higher blood and urinary levels of estrogen.<sup>111,112,113,114,115</sup>

In multiple studies, there has been no correlation between age of menarche and age of menopause, with the exception of one Swedish study concluding that an earlier menarche and earlier menopause go together.<sup>64,95,105,116,117</sup> In most studies, race, parity, and height have no influence on the age of menopause; however, three cross-sectional studies found later menopause to be associated with increasing parity.<sup>64,93,97,105,110</sup> Two studies found that irregular menses among women in their early 40s predicts an earlier menopause.<sup>118,119</sup> A French survey detected no influence of heavy physical work on early menopause (before age 45).<sup>120</sup> An earlier menopause has been reported to be associated with living at high altitudes.<sup>121,122</sup> And most intriguing, an earlier age of menopause has been reported in left-handed women compared with right-handed women.<sup>123,124</sup> Finally, intrauterine growth restriction in late gestation may predispose the affected female progeny to earlier menopause.<sup>125</sup>

It has been suggested, albeit inconsistently, that time to FMP may get accelerated in women undergoing pelvic surgery wherein ovarian vascular supply may get compromised, such as following an abdominal hysterectomy. Effects of pelvic surgery on biomarkers of ovarian reserve have been examined, with mixed results. A prospective study could find no elevations of FSH within the first 2 years after surgery.<sup>126,127,128</sup> Furthermore, in a cross-sectional study assessing ovarian reserve following ovarian cystectomy (for cysts other than endometriomas) and, or salpingectomy, there was no appreciable effect on ovarian reserve.<sup>129</sup>

Multiple studies have consistently documented that an earlier menopause (an



average of 1.5 years earlier) is a consequence of smoking. There is a dose-response relationship with the number of cigarettes smoked and the duration of smoking.<sup>130,131</sup> Even former smokers show evidence of an impact.<sup>101</sup>

Unlike the decline in age of menarche that occurred with an improvement in health and living conditions, most historical investigation indicates that the age of menopause has changed little since early Greek times.<sup>132,133</sup> Others (a minority) have disagreed, concluding that the age of menopause did undergo a change, starting with an average age of about 40 years in ancient times, and in Sweden, an increase of about 1 year over a span of 80 years.<sup>117,134</sup> If there has been a change, however, history indicates that it has been minimal. Even in ancient writings, 50 years is not uncommonly cited as the age of menopause.

# Sexuality, Aging, and Menopause

Sexuality is behavior that evolves and changes across the life span. It begins with birth (maybe before) and ends with death. The notion that sexuality ends with aging is inherently illogical. The need for closeness, caring, and companionship is lifelong. Old people today live longer, are healthier, have more education and leisure time, and have had their consciousness raised in regard to sexuality.

Younger people, especially physicians, underrate the extent of sexual interest in older people. In a random sample of women aged 50–82 in Madison, Wisconsin, nearly one-half of the women reported an ongoing sexual relationship.<sup>135</sup> In the Duke longitudinal study on aging, 70% of men in the 67–77 age group were sexually active, and 80% reported continuing sexual interest, while 50% of all older women were still interested in sex.<sup>136</sup> In the Postmenopausal Estrogen/Progestin Interventions (PEPI) trial, 60% of women 55–64 years old were sexually active.<sup>137</sup> In a national sample of American men and women, the prevalence of sexual behavior declined with aging; however, 26% of individuals aged 75–85 years were still sexually active.<sup>138</sup> The prevalence of self-reported sexual problems peaks in middle-aged women, sufficient to cause distress in about 22% of U.S. women and about 12% of women aged 45–64.<sup>139</sup> Up to 23% of menopausal women are negatively affected by decreased sexual desire.<sup>140</sup>

The decline in sexual activity with aging is influenced by culture and attitudes, as well as by nature and physiology (or hormones). As estradiol regulates serotonergic function, it can affect desire and sexual function.<sup>140</sup> In addition, the discomfort resulting from vaginal dryness and tissue atrophy consequent to low estradiol levels can make coitus unwelcome, even to the point of avoidance. Thus, a significant component of decline in sexual activity in reproductively aging women can be attributed to menopausal symptoms associated with decreasing estrogen levels, a problem that is easily ameliorated by targeted treatment.

There are two main sexual changes in the aging woman. There is a reduction in the rate of production and volume of vaginal lubricating fluid, and there is some loss of vaginal elasticity and thickness of the epithelium. Less vaginal atrophy is noted in sexually active women than in inactive women; presumably, the activity maintains vaginal vasculature and circulation. The spectrum of uncomfortable symptoms that are often described by transitioning and menopausal women with evidence of genital atrophy include a feeling of dryness and tightness, vaginal irritation and burning with penetration, and postcoital spotting and soreness. Given that these symptoms are the direct result of tissue estrogen deprivation, the underlying tissue changes can be effectively prevented by focal estrogen treatment. Systemic estrogen therapy may even have a positive impact on sexuality beyond effects on vaginal tissue.<sup>137</sup> In an ancillary

sexual study of the Kronos Early Estrogen Prevention Study (KEEPS)—a randomized, double-blinded, placebo-controlled trial—early menopausal women were randomized to receive either low-dose oral conjugated equine estrogen (CEE) or transdermal estradiol (transdermal E2), over the 4 years of intervention, while both routes of estrogen treatment resulted in an improvement in vaginal dryness and dyspareunia,<sup>140</sup> improvements in libido and sexual satisfaction were observed only in transdermal E2 users.<sup>140</sup> In an Australian study assessing changes in sexual functioning during the menopausal transition, a correlation with a decline in sexuality was demonstrated with estradiol levels, but not with testosterone levels. There are likely many important factors other than hormone levels that are relevant in determining midlife sexual function.<sup>140,141</sup>

## Illness and Sex

It is not uncommon to encounter medical or surgical underpinnings to disorders of sexuality. Surgical menopause (removal of both ovaries in premenopausal women) is probably one of the most commonly encountered iatrogenic contributors to altered sexual function. Remember that vaginal lubrication is an important physiologic sexual response, and therefore, vaginal dryness is a likely consequence following total hysterectomy even if the premenopausal ovaries are retained. Sexual problems are not limited, however, to surgical procedures and illnesses of the genitalia. Altered self-image such as following vulvectomy or mastectomy can also impact sexual function. However, studies have not found postmenopausal hysterectomy to have a detrimental impact on sexuality.<sup>137,142</sup>

Sexual counseling, to be effective, must be provided to couples both before and after surgery. It is not unexpected that the surgeon may not be fully capable of providing this counseling. A major contribution from an older woman's primary clinician is to arrange for competent and experienced sexual counseling. Unfortunately, most physicians operate on the principle that if no questions are raised, there is no problem. The expert surgeon should be grateful for the help of experts in psychosexual therapy. Seek out the potential for posttreatment sexual morbidity before the surgery. Assess the patient's abilities for coping and her sense of body image. Consider the quality of the patient's relationship, and be sensitive to the absence of a relationship. This entire effort may take some time. The normal state of presurgical anxiety, fear, and denial hampers good communication.

Increasing use of SSRI (selective serotonin reuptake inhibitor) antidepressants is another iatrogenic contributor to female sexual dysfunction that merits attention.<sup>143</sup>

Antihypertensive agents are frequently responsible for male sexual dysfunction, but little information is available regarding female sexual function. Adrenergic blocking

agents are especially noted to affect libido and potency in men. Similarly, psychotropic drugs of all categories have been associated with inhibition of sexual function. Finally, one should always suspect alcoholism when patients complain of sexual dysfunction. Androgen treatment for decreased female sexuality is discussed later in this chapter.

The two most important influences on sexual satisfaction in aging couples are the strength of relationship and the physical condition of each partner.<sup>137,138,144</sup> The single most significant determinant of sexual activity for older women is the lack of availability of partners due to divorce or demise as women are outliving men. Given availability of a partner, the same general high or low rate of sexual activity can be maintained throughout life.<sup>4,145</sup> Longitudinal studies indicate that the level of sexual activity is more stable over time than previously suggested.<sup>146,147,148</sup> Individuals who are sexually active earlier in life continue to be sexually active into old age. However, aging is associated with a decline in sexual function in many women, and this decline has been documented in the years well before the FMP.<sup>149,150</sup>

# HORMONE PROFILE OF MENOPAUSAL TRANSITION AND POSTMENOPAUSE

---

Shortly after the menopause, one can safely say that there are no remaining ovarian follicles.<sup>66,151</sup> Eventually, there is a 10–20-fold increase in FSH and approximately a 3-fold increase in LH, reaching a maximal level 1–3 years after menopause, after which there is a gradual, but slight, decline in both gonadotropins.<sup>152,153</sup> Elevated levels of both FSH and LH at this time in life are conclusive evidence of ovarian failure. FSH levels are higher than LH because LH is cleared from the blood so much faster (initial half-lives are about 20 minutes for LH and 3–4 hours for FSH) and perhaps because there is no specific negative feedback peptide for LH like inhibin. An aging-related decline in the gonadotropin levels in the latter years of postmenopausal life is well described and is believed to reflect aging of the pituitary gonadotropin-secreting cells, specifically a decrease in the ability to respond to the hypothalamic gonadotropin-releasing hormone (GnRH).

After menopause, the ovary secretes primarily androstenedione and testosterone, but the circulating level of androstenedione after menopause is about one-half that seen prior to menopause.<sup>154</sup> Most of this postmenopausal androstenedione is derived from the adrenal gland, with only a small amount secreted from the ovary, even though androstenedione is the principal steroid secreted by the postmenopausal ovary.<sup>155,156</sup> Dehydroepiandrosterone (DHEA) and its sulfate (DHEA-S), originating in the adrenal gland, decline markedly with aging; in the decade after menopause, the circulating levels of DHEA are approximately 70% less and levels of DHEA-S are about 74% less than the levels in young adult life.<sup>157,158</sup>

Testosterone production decreases by approximately 25% after menopause, but the postmenopausal ovary in most, but not all women, secretes more testosterone than the premenopausal ovary, at least in the first years of the postmenopausal period. With the disappearance of follicles and estrogen, the elevated gonadotropins drive the remaining tissue in the ovary to a level of increased testosterone secretion. The ovarian cells of origin are uncertain; presumably, the steroidogenic tissue is that which has accumulated from ovarian follicles undergoing atresia because stromal cells believed to be of mesenchymal origin lack steroidogenic capability.<sup>159</sup> Suppression of gonadotropins with GnRH agonist or antagonist treatment of postmenopausal women results in a significant decrease in circulating levels of testosterone, indicating the gonadotropin-dependent postmenopausal ovarian origin.<sup>160,161,162</sup>

The total amount of testosterone produced after menopause, however, is decreased because the amount of the primary source, peripheral conversion of androstenedione, is

reduced. The early postmenopausal circulating level of androstenedione decreases approximately 62% from young adult life.<sup>157</sup> **The menopausal decline in the circulating levels of testosterone is not great, from no change in many women to as much as 15% in others.**<sup>59,153,157,163,164</sup> In an excellent longitudinal Australian study from 5 years before menopause to 7 years after menopause, the circulating levels of testosterone did not change.<sup>158</sup> Indeed, because of a decrease in sex hormone-binding globulin (SHBG), this Australian study calculated an increase in free androgens. Late postmenopause may be considered as a state of **relative androgen excess**.

Later in the postmenopausal years, the circulating androgen levels are nearly all, if not all, derived from the adrenal gland. A careful study could detect no circulating androgens in postmenopausal women (averaging 12 years distant from menopause) with complete adrenal insufficiency and no intraovarian testosterone or androstenedione.<sup>165</sup>

The circulating estradiol level after menopause is approximately 10–20 pg/mL, most of which is derived from peripheral conversion of estrone, which in turn is mainly derived from the peripheral conversion of androstenedione.<sup>154,166,167</sup> The circulating level of estrone in postmenopausal women is higher than that of estradiol, approximately 30–70 pg/mL (Table 17.4). The average postmenopausal production rate of estrogen is approximately 45 µg/24 h, almost all, if not all, being estrogen derived from the peripheral conversion of androgens. The androgen/estrogen ratio changes drastically after menopause because of the more marked decline in estrogen, and an onset of mild hirsutism is common, reflecting this marked shift in the sex hormone ratio. With increasing postmenopausal age, a decrease can be measured in the circulating levels of dehydroepiandrosterone sulfate (DHEA-S) and DHEA, whereas the circulating postmenopausal levels of androstenedione, testosterone, and estrogen remain relatively constant.<sup>153,154</sup>

## TABLE 17.4

**Blood Production Rates of Steroids<sup>168</sup>**

	<i>Reproductive Age</i>	<i>Postmenopausal</i>	<i>Oophorectomized</i>
Androstenedione	2–3 mg/day	0.5–1.5 mg/day	0.4–1.2 mg/day
Dehydroepiandrosterone	6–8	1.5–4.0	1.5–4.0
Dehydroepiandrosterone sulfate	8–16	4–9	4–9
Testosterone	0.2–0.25	0.05–0.18	0.02–0.12
Estrogen	0.350	0.045	0.045

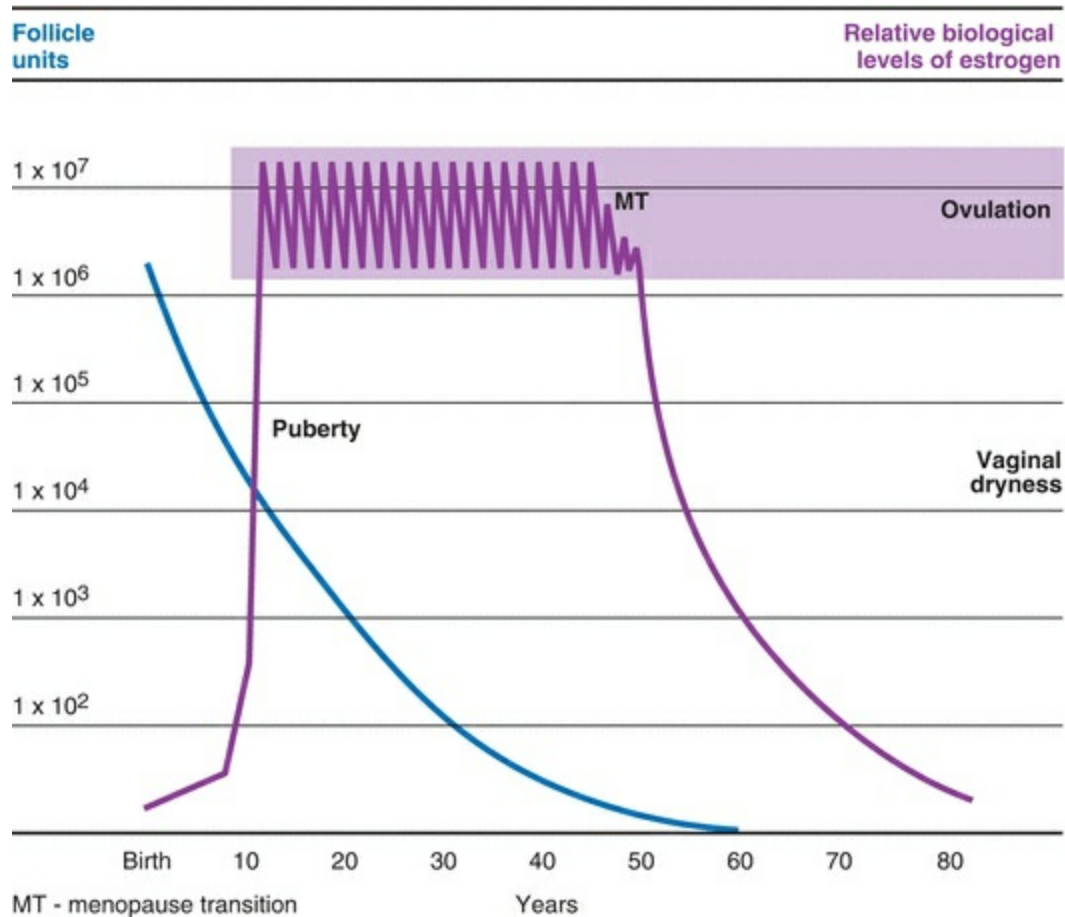
**Changes in Circulating Hormone Levels at Menopause<sup>59,154,166</sup>**

	<i>Premenopause</i>	<i>Postmenopause</i>
Estradiol	40–400 pg/mL	10–20 pg/mL
Estrone	30–200 pg/mL	30–70 pg/mL
Testosterone	20–80 ng/dL	15–70 ng/dL
Androstenedione	60–300 ng/dL	30–150 ng/dL

Estrogen production by the ovaries does not continue beyond the menopause; however, estrogen levels in postmenopausal women can be significant, principally due to the extraglandular conversion of androstenedione and testosterone to estrogen. The clinical impact of this estrogen varies from one postmenopausal woman to another, depending on the degree of extraglandular production, modified by a variety of factors.

The percent conversion of androstenedione to estrogen correlates with body weight. Increased production of estrogen from androstenedione with increasing body weight is probably due to the ability of fat to aromatize androgens. This fact and a decrease in the levels of SHBG (which results in increased free estrogen concentrations) contribute to the well-recognized association between obesity and the development of endometrial cancer. Body weight, therefore, has a positive correlation with the circulating levels of estrone and estradiol.<sup>154</sup> Aromatization of androgens to estrogens is not limited to adipose tissue, however, because almost every tissue tested has this activity.

Eventually, the ovarian steroidogenic tissue is exhausted and, despite huge reactive increments in FSH and LH, no further steroidogenesis of importance results from gonadal activity. The postmenopausal ovary weighs less than 10 g, but it can be visualized by ultrasonography.<sup>169</sup> With increasing age, the adrenal contribution of precursors for estrogen production proves inadequate. In this final stage of estrogen availability, levels are insufficient to sustain secondary sex tissues, such as the genitourinary epithelium (**Figure 17.9**).



**FIGURE 17.9**

In summary, the symptoms frequently seen and related to decreasing ovarian follicular competence and then estrogen loss in this protracted climacteric are:

- Disturbances in menstrual pattern, including anovulation and reduced fertility, decreased flow or hypermenorrhea, irregular frequency of menses, and then, ultimately, amenorrhea
- Vasomotor instability (hot flashes and sweats)
- Atrophic conditions: atrophy of the vaginal epithelium; formation of urethral caruncles; dyspareunia and pruritus due to vulvar, introital, and vaginal atrophy; general skin atrophy; and urinary difficulties such as urgency and abacterial urethritis and cystitis
- Health problems secondary to long-term deprivation of estrogen: the consequences of osteoporosis and cardiovascular disease

A precise understanding of the symptom complex the individual patient may display is often difficult to achieve. Some patients experience severe multiple reactions that may be disabling. Others show no reactions or minimal reactions that go unnoticed until



careful medical evaluation.

**It is helpful to classify the hormonal problems in three categories:**

- 1. Those associated with relative estrogen excess such as abnormal uterine bleeding, endometrial hyperplasia, and endometrial cancer**
- 2. Those associated with estrogen deprivation such as flushes, atrophic vaginitis, urethritis, and osteoporosis**
- 3. Those associated with hormone therapy (discussed later in this chapter)**

# SYMPTOMATOLOGY OF PERIMENOPAUSE AND MENOPAUSE

---

The period of transition should serve to remind both the patients and the clinicians that this is a time for communication to ensure improvements in patient awareness through education. Certainly, preventive health care education is important throughout life, but at the time of the menopause, a review of the major health issues can be especially rewarding. Besides the general issues of good health, attention is appropriately focused on cardiovascular disease and osteoporosis.

During the transition and early postmenopausal years in particular, some women may experience significantly bothersome symptoms, whereas others show no reactions or minimal reactions that can go unnoticed. The differences in menopause experience and in the spectrum and severity of symptoms across different cultures are poorly documented, and indeed, it is difficult to do so. Individual reporting is so conditioned by sociocultural factors that it is hard to determine what is due to biologic versus cultural variability.<sup>170,171</sup> For example, there is no word to describe a hot flush in Japanese, Chinese, and Mayan.<sup>172</sup> Nevertheless, there is reason to believe that the nature and prevalence of menopausal symptoms are common to most women and that variations among cultures and within cultures reflect not physiology, but differences in attitudes, lifestyles, socioeconomic status, and individual perceptions across societies.<sup>173,174,175,176,177,178</sup> Hormone levels during the perimenopausal years vary little among different ethnic groups; differences are mainly because of varying body sizes.<sup>179</sup>

# Abnormal Uterine Bleeding

Period of transition is characterized by an increasing incidence of anovulatory uterine bleeding. Thus, the late reproductive and early menopausal stages are characterized by longer periods of exposure to unopposed estrogen, of ovarian and extraovarian (from aromatization of androgens) origins. In the SWAN study, about 20% of cycles even early in the menopausal transition were anovulatory, associated with shorter intervals at the beginning of the transition and longer intervals later.<sup>180</sup> Irregular bleeding was most often due to anovulation, whereas heavy menstrual bleeding was associated with obesity and uterine abnormalities. The menopause transition and early menopause can thus be considered as times of relative estrogen excess. Although the greatest concern emerging from prolonged periods of exposure to estrogen unopposed by progesterone is of endometrial neoplasia, the most common of tissue finding is that of nonneoplastic tissue displaying estrogen effects unopposed by progesterone.

**In addition to relative excess of estrogen resulting from anovulation, there are four mechanisms that could result in higher endogenous estrogen levels in perimenopausal and menopausal women:**

- 1. Increased precursor androgen (functional endocrine tumors, liver disease, stress)**
- 2. Increased aromatization (obesity, hyperthyroidism, and liver disease)**
- 3. Increased direct secretion of estrogen (ovarian tumors)**
- 4. Decreased levels of SHBG (sex hormone–binding globulin) leading to increased levels of free estrogen**

In those presenting with abnormal uterine bleeding, whether perimenopausal or postmenopausal, whether on or off hormone therapy, specific organic causes for abnormal uterine bleeding (neoplasia, complications of unexpected pregnancy, or bleeding from extrauterine sites) must be ruled out. In addition to a careful history and physical examination, abnormal uterine bleeding, particularly in an aging individual, requires systematic endometrial evaluation. Transvaginal ultrasound (TVUS) measurement of endometrial thickness can be utilized in postmenopausal women to avoid unnecessary biopsies.<sup>181</sup> In postmenopausal women with abnormal bleeding, endometrial biopsy is considered unnecessary when the endometrial thickness on ultrasound is less than 4 mm as the risk of endometrial hyperplasia or cancer in this setting is unlikely.<sup>182,183,184</sup> Substantial evidence is however lacking to support the application of this criterion to the premenopausal population. **We believe that biopsy is unnecessary in postmenopausal women when the endometrial thickness is 4 mm or less. We further believe that endometrial biopsy is indicated when the clinical**

**history suggests long-term unopposed estrogen exposure (either prolonged periods of oligo-/amenorrhea in pre- and perimenopausal women or with iatrogenic estrogen use) even when the endometrial thickness is “normal” (5–12 mm for premenopausal women) and that biopsy should be considered when endometrial thickness is greater than 12 mm in the absence of abnormal uterine bleeding, even when clinical suspicion of disease is low.** A TVUS study can also help in identifying intracavitary lesions, particularly with intracavitary instillation of saline.<sup>185</sup> Saline infusion sonohysterogram (SHG) can identify intracavitary lesions (i.e., polyps and submucosal fibroids) that can be missed on routine 2D TVUS.<sup>185</sup> The sensitivity and specificity of TVUS for identifying intrauterine pathology are 56–73%,<sup>186</sup> whereas SHG has a sensitivity of 96–100% and a negative predictive value of 94–100% in evaluating for uterine pathology.<sup>185</sup> Hysteroscopy has an accuracy of 96% for intracavitary pathology, with abnormalities seen in about 47% of premenopausal and postmenopausal women with abnormal uterine bleeding.<sup>154</sup>

If the endometrial assessment is unremarkable but abnormal bleeding persists, then for reasons of both accuracy and cost-effectiveness, the next step should be of endometrial biopsy; when no focal pathology is evident on screening, then it is appropriate for the method of endometrial biopsy to be an office-based procedure. We recommend the use of a plastic endometrial suction device (such as a pipelle) as the procedure is easy to perform, requires no cervical dilation, and is frequently well tolerated and equipment is routinely available even in low-resource settings. An office-based endometrial biopsy has been shown to offer tissue yield that is near comparable to dilation and curettage (D&C) and has an 83% sensitivity for detecting endometrial cancer. Insertion should first be attempted without the use of a tenaculum. In many patients, this is feasible and avoids the sensation of the tenaculum grasping the cervix. Once the suction is applied, the endometrial cavity should be thoroughly curetted in all directions, just as one would with a sharp curette during a D&C. Although most patients report no problems with cramps or pain, the application of suction in some patients stimulates cramping that usually passes within 5–10 minutes. Because cramping can occur, an inhibitor of prostaglandin synthesis given at least 20 minutes before the procedure has been shown to minimize procedure-related discomfort. Less than 10% of postmenopausal women cannot be adequately evaluated by office biopsy. Most commonly, the reason is the inability to negotiate the cervical canal and gain entry into the uterine cavity. In such instances, it is very reasonable to proceed with procedure under anesthesia when a D&C can be performed in the operating room; however, pretreatment with misoprostol or cervical laminaria may allow completion of office endometrial biopsy and thus avoid the need for anesthesia and D&C. We recommend consideration for office hysteroscopy or a SHG prior to proceeding with office endometrial biopsy and undertaking concomitant hysteroscopy at the time of D&C being

undertaken for evaluation of abnormal uterine bleeding,<sup>154</sup> provided access to the equipment is available and the surgeon has the requisite expertise. Following a negative hysteroscopy result, the chance of endometrial cancer diagnosis is 0.4–0.5%.<sup>154</sup> If the vulva, vagina, and cervix appear normal on inspection, menopausal bleeding can be assumed to be intrauterine in origin. Confirmation requires the absence of abnormal cytology on the Pap smear. The principal symptom of endometrial cancer is abnormal vaginal bleeding, but carcinoma will be encountered in patients with bleeding in less than 3% of postmenopausal endometrial biopsies.<sup>187,188,189</sup> Normal endometrium is found over half the time, polyps in approximately 3%, endometrial hyperplasia about 15% of the time, and atrophic endometrium in the rest of patients with postmenopausal bleeding. Postmenopausal bleeding should always be taken seriously. Approximately 10% of patients who have benign findings at the initial evaluation subsequently develop significant pathology within 2 years.<sup>188</sup> **The persistence of abnormal bleeding demands repeated evaluation.**

Additional procedures to consider include the following:

- **Colposcopy and cervical biopsy** for abnormal cytology or obvious lesions
- **Endocervical assessment** by curettage for abnormal cytology (the endocervix must always be kept in mind as a source for abnormal cytology)

Keep in mind that the pathologic reading, “tissue insufficient for diagnosis,” when a patient is on estrogen-progestin treatment, often represents atrophic, decidualized endometrium that yields little to the exploring curette. If the clinician is confident in his or her technique, knowing that a full investigation of the intrauterine cavity has been accomplished, then as long as the patient does not persist in bleeding, this reading can be interpreted as comforting and benign, the absence of pathology. Specifically, as long as the clinician is certain that the true uterine cavity was sampled (i.e., no false passage or stenotic os encountered), then no further testing is indicated unless abnormal bleeding persists and risk factors for neoplasia are present. In the event of continued bleeding or concerning risk factors (i.e., long-standing history of unopposed estrogen, obesity, hypertension, diabetes, nulliparous), consideration for referral to a gynecologic oncologist would be a prudent approach.

In the absence of organic disease, appropriate management of uterine bleeding is dependent on the age of the woman and endometrial tissue findings. In the menopausal woman with abnormal uterine bleeding associated with evidence of simple endometrial hyperplasia (uncomplicated by atypia or dysplastic constituents), periodic oral progestin therapy is mandatory (such as 10 mg medroxyprogesterone acetate or 5–10 mg norethindrone acetate for 14 days each month). Intrauterine placement of a levonorgestrel intrauterine device (LNG-IUD) is increasingly being utilized as an

effective management approach with high regression rates. Higher-dose oral progestins (such as 10–20 mg medroxyprogesterone acetate or 10–15 mg norethindrone acetate) are always an option and should be considered in the setting of obesity.<sup>190,191</sup> Repeat endometrial sampling should be performed at 3 and 6 months of therapy. Most cases of simple hyperplasia will regress at 6 months; however, if there is no regression at 3–6 months, then consideration of increasing progestin dose or switching regimen (such as to megestrol acetate in daily doses of 40–80 mg or LNG-IUD) should be entertained. Persistence or progression of abnormal endometrium was observed in 28.4% of women with complex hyperplasia and in 26.9% of women with atypical hyperplasia despite treatment with a progestational agent.<sup>192</sup> At least two consecutive repeat negative biopsies should be conducted prior to stopping surveillance.<sup>190</sup> In the absence of any regression after 1 year of progestin therapy, or if there is evidence of progression from simple or complex without atypia to atypical hyperplasia despite progestin therapy, then hysterectomy is indicated and referral to a gynecologic oncologist is strongly advised.<sup>190</sup> Because hyperplasia with atypia carries with it a risk of concomitant cancer (even invasive), hysterectomy is the treatment of choice. However, progestational response was better with higher-dosage and longer-duration treatment. If histologic regression is not observed on office biopsy, a D&C should be considered before proceeding with hysterectomy.

Clinicians have often utilized a traditional postmenopausal hormone regimen to treat a woman with the kind of irregular cycles usually experienced in the perimenopausal years. This addition of exogenous estrogen without a contraceptive dose of progestin when a woman is not amenorrheic or experiencing menopausal symptoms is inappropriate and even risky (exposing the endometrium to excessively high levels of estrogen). **And most importantly, a postmenopausal hormonal regimen does not inhibit ovulation and provide contraception.**<sup>193</sup> The appropriate response is to regulate anovulatory cycles with monthly progestational treatment along with an appropriate contraceptive method or to utilize low-dose estrogen-progestin contraception. An oral contraceptive that contains 20 µg estrogen provides effective contraception, improves menstrual cycle regularity, diminishes bleeding, and relieves menopausal symptoms.<sup>194</sup> Treatment with the transdermal or vaginal method of estrogen-progestin contraception would also be appropriate.

A common clinical dilemma is when to change from estrogen-progestin contraception to postmenopausal hormone therapy. It is important to change because even with the lowest estrogen dose contraceptive available, the estrogen dose is fourfold greater than the standard postmenopausal dose, and with increasing age, the dose-related risks with estrogen become significant. One approach to establish the onset of the postmenopausal years is to measure the FSH level, beginning at age 50, on an

annual basis, being careful to obtain the blood sample on day 6 or 7 of the estrogen-progestin-free week in a standard 3-week regimen (when steroid levels have declined sufficiently to allow FSH to rise). Friday afternoon works well for patients who start new estrogen-progestin treatment on Sunday. When FSH is greater than 20 IU/L, it is time to change to a postmenopausal hormone program. Because of the variability in FSH levels experienced by women around the menopause, this method is not always accurate.<sup>195,196</sup> Indeed, in some women, FSH will not rise until 2 weeks after the last steroid contraception exposure. A 2-week wait is not very practical and places the patient at risk for an unwanted pregnancy. The treatment-free week method is practical and works for most women. Women who are dependent on contraceptives to prevent pregnancy can be allowed to enter their mid-50s on low-dose estrogen-progestin contraception and then empirically switched to a postmenopausal hormone regimen. **The empirical approach is necessary with patients using the newer extended-day or continuous dosing regimens of estrogen-progestin contraception.**

Because of the favorable impact of locally released progestin on the endometrium, the LNG-IUD is very effective for the treatment of menorrhagia, as effective as the administration of oral progestins (with less side effects), and compares favorably with endometrial resection or ablation.<sup>197,198,199,200,201</sup> In addition, this IUD can be used to treat endometrial hyperplasia.<sup>202,203,204,205,206,207</sup> Comparison studies of endometrial hyperplasia indicate that the levonorgestrel IUD is more effective than standard treatment with an oral progestin.<sup>203,208,209,210</sup> The levonorgestrel IUD may be associated with a slight increase in the formation of ovarian cysts, but they are asymptomatic and resolve spontaneously.<sup>211</sup>

In postmenopausal women, one must view any adnexal mass as cancer until proven otherwise. Surgical intervention is usually necessary, and appropriate consultation must be obtained not only for the surgical procedure but also for suitable preoperative evaluation and preparation. Nonpalpable, asymptomatic ovarian cysts are commonly detected by ultrasonography. Cysts that are less than 10 cm in diameter and without septations or solid components (unilocular) have a very low potential for malignant disease and can be managed with serial ultrasound surveillance (at 3 months, 6 months, 12 months, and then annually), especially if the serum CA 125 is normal.<sup>212,213</sup> Surgery is recommended for symptomatic cases, if growth occurs, if internal echoes are obtained, if fluid develops in the pelvis, or if there is a family history of breast or ovarian cancer.

# Vasomotor Symptoms

The vasomotor flush is viewed as the hallmark of the female climacteric, experienced to some degree by most postmenopausal women. The term “hot flush” or “hot flash” is descriptive of a sudden onset of reddening of the skin over the head, neck, and chest, accompanied by an increase in heart rate and a feeling of intense body heat. The flush is sometimes concluded by profuse perspiration. The duration varies from a few seconds to several minutes and, rarely, for an hour. The frequency may be rare to recurrent every few minutes. Flushes are more frequent and severe at night (when a woman is often awakened from sleep) or during times of stress. In a cool environment, hot flushes are fewer, less intense, and shorter in duration compared with a warm environment.<sup>214</sup> Most importantly, hot flushing can affect a woman’s quality of life and interfere with work or recreational activities.

In the longitudinal follow-up of a large number of women, fully 10% of the women experienced hot flushes before menopause, while in other studies, as many as 15–25% of premenopausal women reported hot flushes.<sup>8,93,215,216</sup> The frequency has been reported to be even higher in premenopausal women diagnosed with PMS.<sup>217</sup> In the Massachusetts Women’s Health Study, the incidence of hot flushes increased from 10% during the premenopausal period to about 50% just after cessation of menses.<sup>93</sup> By approximately 4 years after menopause, the rate of hot flushes declined to 20%. In a community-based Australian survey, 6% of premenopausal women, 26% of perimenopausal women, and 59% of postmenopausal women complained of hot flushing.<sup>218</sup> A large American cross-sectional survey reported that 57% of perimenopausal women and 49% of early postmenopausal women experienced significant hot flushing.<sup>177</sup> Another national survey in the United States reported hot flushing in 79% of perimenopausal women and 65% of postmenopausal women.<sup>219</sup>

In cross-sectional surveys, up to 40% of premenopausal women and 85% of menopausal women report some vasomotor complaints.<sup>216</sup> A longitudinal study in Gothenburg, Sweden, recorded a maximal prevalence of 60% at age 52–54, with a decline to 30% at age 60 and 9% at age 72.<sup>220</sup> In the SWAN study, 57% of perimenopausal women experienced hot flushing and about 50% after menopause up to age 55.<sup>221</sup> There is no difference in the prevalence of vasomotor complaints in U.S. surveys of black and white women.<sup>222,223</sup> Overweight women report more hot flushing, perhaps reflecting the effect of body fat causing a higher core body temperature.<sup>177,179,224</sup> Exact estimates on prevalence are hampered by inconsistencies and differences in methodologies, cultures, and definitions.<sup>225</sup> The prevalence in different societies is influenced by personal and social attitudes, individual psychological and physical health, familiarity with the portrayal of menopausal issues in



the literature and media, ethnic variation, different diets, and dissimilar living conditions; however, accounting for cultural differences, the overall prevalence and experience are similar throughout the world.<sup>226,227</sup>

**Although the flush can occur in the premenopause, it is a major feature of the menopause transition and postmenopause, peaking in the first year after the last menses, lasting in 50% of women for 4–5 years, but in some (as many as 25%) for longer than 5 years, and even up to 15 years in 10% (Table 17.5).<sup>228</sup> In an excellent Australian longitudinal cohort study, the average duration of vasomotor symptoms was 5.2 years (with a range of 2–10 years) in nonusers of hormone therapy and slightly longer, 5.5 years, in hormone users.<sup>229</sup> In the SWAN cohort, the median total duration of vasomotor symptoms was 7.4 years. Women who were premenopausal or early perimenopausal at first reporting of frequent symptoms experienced the longest duration (median, >11.8 years) and post-FMP persistence (median, 9.4 years), whereas women who first experienced vasomotor symptoms after onset of menopause had the shortest total duration of symptom (median, 3.4 years).<sup>230</sup>**

## **TABLE 17.5 The Hot Flush**



Premenopausal	10–25% of women
Perimenopausal	60%
Postmenopausal:	
No flushes	15–25%
Daily flushing	15–25%
Duration	1–2 years average: 15–20% 5 or more years: 25%
Other Causes	Psychosomatic Stress Thyroid disease Subacute, chronic infections Pheochromocytoma Carcinoid Leukemia Cancer

The physiology of the hot flush is still not understood. Studies suggest that women with hot flushes have a more narrow zone of temperature regulation, and therefore, smaller changes in core body temperature produce compensatory responses, such as shivering or flushing.<sup>231</sup> MRI scanning of the brain during hot flushing indicates widely distributed cortical activation rather than a precise location.<sup>232</sup> Hot flushes are definitely brought about by a decline in estrogen; however, not all hot flushes are due to estrogen deficiency. Flushes and sweating can be secondary to diseases, including pheochromocytoma, carcinoid, leukemias, pancreatic tumors, and thyroid

abnormalities.<sup>233</sup> **When the clinical situation is not clear and obvious, estrogen deficiency as the cause of hot flushes should be documented by elevated levels of FSH.**

The correlation between the onset of flushes and estrogen reduction is clinically supported by the effectiveness of estrogen therapy and the absence of flushes in hypoestrogen states, such as gonadal dysgenesis. Only after estrogen is administered and withdrawn do hypogonadal women experience the hot flush. Although the clinical impression that premenopausal surgical castrates suffer more severe vasomotor reactions is widely held, this was not borne out in the only objective study ever performed.<sup>234</sup>

Although the hot flush is the most common problem of the postmenopause, it presents no inherent health hazard. The flush is accompanied by a discrete and reliable pattern of physiologic changes.<sup>231,235</sup> The flush coincides with a surge of LH (not FSH) and is preceded by a subjective prodromal awareness that a flush is beginning. This aura is followed by measurable increased heat over the entire body surface. A flush is triggered by a small elevation in core body temperature. The body surface experiences an increase in temperature, accompanied by changes in skin conductance, and then the flush is followed by a fall in core temperature—all of which can be objectively measured. In short, the flush is not a release of accumulated body heat but is a sudden inappropriate excitation of heat release mechanisms. Its relationship to the LH surge and temperature change within the brain is not understood. The observation that flushes occur after hypophysectomy indicates that the mechanism is not dependent on or due directly to LH release. In other words, the same brain event that causes flushes also stimulates GnRH secretion and elevates LH. This is probably secondary to hypothalamic changes in neurotransmitters that increase neuronal and autonomic activity.<sup>236</sup>

Premenopausal women experiencing hot flushes should be screened for thyroid disease and other illnesses. A comprehensive review of all possible causes is available.<sup>237</sup> Clinicians should be sensitive to the possibility of an underlying emotional problem. Looking beyond the presenting symptoms into the patient's life is an important service to the patient and her family that eventually will be appreciated. This is far more difficult than simply prescribing estrogen, but confronting problems is the only way of reaching some resolution.

A striking and consistent finding in most studies dealing with menopause and hormonal therapy is a marked placebo response (at least 51% in the first weeks of treatment)<sup>238</sup> in a variety of symptoms, including flushing. In an English randomized, placebo-controlled study of women being treated with estrogen implants and requesting repeat implants, there was no difference in outcome in terms of psychological and

physical symptoms comparing the women who received an active implant to those receiving a placebo.<sup>239</sup>

A significant clinical problem encountered in our referral practice is the following scenario: a woman will occasionally undergo an apparently beneficial response to estrogen, only to have the response wear off in several months despite ongoing use of prescribed hormonal regimen. Rather than continuously increasing the estrogen dose, it is important to consider altering the mode of delivery (i.e., switching from oral to transdermal) or timing of medication (i.e., if administering orally, consider twice-daily dosing if giving estradiol as opposed to CEE). Importantly, uncommon differential diagnoses, such as pheochromocytoma or carcinoid, must be entertained when encountering recalcitrant vasomotor symptoms that remain unresponsive to increasing doses of estrogen therapy. Additionally, a careful inquiry must be undertaken to search for underlying psychosocial problems. To help persuade a patient that her symptoms are not due to low levels of estrogen, we find it very helpful and convincing to measure the patient's blood level of estradiol and share the result with her.

# Atrophic Changes: The Genitourinary Syndrome of Menopause

With extremely low estrogen production in the late postmenopausal age, or many years after castration, atrophy of vaginal mucosal surfaces takes place, accompanied by vaginitis, pruritus, dyspareunia, and stenosis. Genitourinary atrophy leads to a variety of symptoms that affect the ease and quality of living. Urethritis with dysuria, urgency incontinence, and urinary frequency are further results of mucosal thinning, in this instance, of the urethra and bladder. Recurrent urinary tract infections are effectively prevented by postmenopausal intravaginal estrogen treatment.<sup>240</sup> Vaginal relaxation with cystocele, rectocele, and uterine prolapse, and vulvar dystrophies are not a consequence of estrogen deprivation.

Deprived of estrogen, the vagina loses collagen, adipose tissue, and the ability to retain water. As the vaginal walls shrink, the rugae flatten and disappear. The surface epithelium loses its outer fibrous layer and thins to a few layers of cells, markedly reducing the ratio of superficial to basal cells. As a result, the vaginal surface is left friable, prone to bleeding with minimal trauma. While these changes are occurring, the blood vessels in the vaginal walls narrow, and secretions from sebaceous glands diminish. Over time, the vagina itself contracts and loses flexibility, while the labia minora become paler and smaller. In addition, pH becomes more alkaline, making the vaginal environment less hospitable to lactobacilli and more susceptible to infection by urogenital and fecal pathogens. Infecting organisms can ascend into the urinary system to cause urethritis, urinary tract infections, and cystitis.

Dyspareunia, sometimes with postcoital bleeding, is the inevitable consequence of a severely atrophied vagina and scanty lubrication. Even for women who are not sexually active, atrophic vaginitis can cause itching, irritation, and burning. These symptoms often go unmentioned, and it is important to inspect for signs of vaginal atrophy even in the absence of complaints. **Measuring pH is a simple way to determine estrogen's influence or absence. A pH greater than 4.5 is almost always observed with estrogen deficiency.**<sup>241,242</sup>

Dyspareunia seldom brings older women to our offices. A basic reluctance to discuss sexual behavior still permeates our society, especially among older patients and physicians. Gentle questioning may lead to estrogen treatment of atrophy and enhancement of sexual enjoyment. Objective measurements have demonstrated that vaginal factors that influence the enjoyment of sexual intercourse can be maintained by appropriate doses of estrogen.<sup>243</sup> Both patient and clinician should be aware that a significant response can be expected by 1 month, but it takes a long time to fully restore the genitourinary tract (6–12 months), and clinicians and patients should not be

discouraged by an apparent lack of immediate response. Raloxifene and tamoxifen have little impact on the vaginal epithelium, and vaginal dryness is worse with aromatase inhibitors. Sexual activity by itself supports the circulatory response of the vaginal tissues and enhances the therapeutic effects of estrogen. Therefore, sexually active older women have less atrophy of the vagina even without estrogen.

Although it is argued that genuine stress incontinence is not affected by treatment with estrogen, others contend that estrogen treatment improves or cures stress incontinence in over 50% of patients due to a direct effect on the urethral mucosa.<sup>244,245,246</sup> A meta-analysis concluded that improvement was reported only in nonrandomized studies.<sup>247</sup> Two randomized trials dedicated to this clinical problem failed to demonstrate a beneficial effect of estrogen treatment.<sup>248,249</sup> Most cases of urinary incontinence in elderly women are a mixed problem with a significant component of urge incontinence that is believed to be improved by estrogen therapy. However, the Heart and Estrogen-Progestin Replacement Study (HERS) randomized trial indicated a worsening of incontinence with hormone therapy for both urge and stress incontinence, and the Nurses' Health Study reported a small increase of incontinence in hormone users.<sup>250,251</sup> In the SWAN study, only 15% of incontinent women reported a worsening of urinary incontinence during the menopausal transition, largely because of weight gain.<sup>252</sup> The majority of incontinent women experienced either no change or an improvement. The SWAN study results imply that urinary incontinence is not a major symptom of menopause and the perimenopausal transition.<sup>252,253</sup> In contrast, a Cochrane review from 2012 found that compared to placebo, women who received local estrogen-based therapy for incontinence noted improvement in symptoms.<sup>254</sup> Interestingly, in trials using oral estrogen, women reported worsening of urinary symptoms.<sup>255</sup> **New-onset incontinence at midlife is not a consequence of hormonal changes.**

A decline in skin collagen content, elasticity, and skin thickness that occurs with aging can be considerably avoided by postmenopausal estrogen therapy.<sup>256,257,258,259,260</sup> The effect of estrogen on collagen is evident in both bone and skin; bone mass and collagen decline in parallel after menopause, and estrogen treatment reduces collagen turnover and improves collagen quality.<sup>261,262</sup> One study demonstrated not only an increase in facial skin thickness, but an improvement in wrinkles with topical estrogen.<sup>263</sup> A randomized trial demonstrated improvements in skin elasticity, skin hydration, and skin thickness comparing hormone treatment with placebo.<sup>264</sup> More impressively, data from the U.S. First National Health and Nutrition Examination Survey (NHANES) indicated that estrogen use was associated with a lower prevalence of skin wrinkling and dry skin.<sup>265</sup> Smoking is a major risk factor for facial skin

wrinkling, and hormone therapy cannot diminish this impact of smoking.<sup>266</sup> In a 1-year clinical trial, hormone therapy did not improve skin wrinkling already present.<sup>267</sup>

One of the features of aging in men and women is a steady reduction in muscular strength. Many factors affect this decline, including height, weight, and level of physical activity. Women currently using estrogen have been reported to demonstrate a lesser decline in muscular strength, although at least one study could detect no impact of estrogen.<sup>268,269,270,271,272,273</sup> This is an important issue because of the potential protective consequences against fractures, as well as a benefit due to the ability to maintain vigorous physical exercise.

# Mental Health

The view that menopause has a deleterious effect on mental health is not supported in the psychiatric literature or in surveys of the general population.<sup>215,216,274,275</sup> The concept of a specific menopause-induced psychiatric disorder (involutional melancholia) has been abandoned. Indeed, depression is less common, not more common, among middle-aged women, and the menopause cannot be linked to psychological distress.<sup>2,3,4,5,6,7,8,276</sup> The longitudinal study of premenopausal women indicates that hysterectomy with or without oophorectomy is not associated with a negative psychological impact among middle-aged women.<sup>277</sup> Longitudinal data from the Massachusetts Women's Health Study document that menopause is not associated with an increased risk of depression.<sup>278</sup> Although women are more likely to experience depression than men, this sex difference begins in early adolescence, not at menopause.<sup>279</sup>

The U.S. National Health Examination Follow-up Study includes both longitudinal and cross-sectional assessments of a nationally representative sample of women. This study has found no evidence linking either natural or surgical menopause to psychological distress.<sup>280</sup> Indeed, the only longitudinal change was a slight decline in the prevalence of depression as women aged through the menopausal transition. Results in this study were the same in estrogen users and nonusers.

**A negative view of mental health at the time of the menopause is not justified; many of the problems reported at the menopause are due to life events.**<sup>10,11,281,282</sup> Thus, there are problems encountered in the perimenopausal transition and the early postmenopause that are seen frequently, but their causal relation with estrogen is unlikely. These problems include fatigue, nervousness, headaches, insomnia, depression, irritability, and palpitations. Indeed, at this stage of life, both men and women express a multitude of complaints that do not reveal a gender difference that could be explained by a hormonal cause.<sup>283,284</sup> Nevertheless, midlife women report complaints more often than men,<sup>284</sup> perhaps reflecting the generally negative perceptions and connotations our cultures and societies have attributed to the menopause.

Sleep disturbances are a common complaint during the menopausal transition and in early postmenopausal years.<sup>285</sup> Difficulties with falling to sleep and with staying asleep, sleep interruptions, and early awakenings are all more often encountered during menopause transition and postmenopause compared to during the reproductive stage of aging. Disordered sleep itself can negatively affect health outcomes, including risk of depression.<sup>285</sup> While hormonal changes can affect sleep, it has been difficult to establish the extent to which hormonal changes contribute to poor sleep. Several epidemiologic



studies have demonstrated that men and women, upon entering midlife, experience poor sleep quality.<sup>286</sup> Increased nighttime awakening and overall loss of total sleep time are common in women in the menopausal transition and postmenopausal.<sup>286</sup> Perhaps not surprisingly, nocturnal vasomotor symptoms (hot flushes and night sweats) likely contribute to sleep disturbances.<sup>286</sup> The underlying body temperature dysregulation and stress activation during episodes of vasomotor phenomenon are detrimental to sleep.<sup>286</sup> Studies assessing correlation between vasomotor symptoms and sleep patterns on polysomnography, however, are conflicting suggesting existence of unidentified confounders.<sup>286</sup>

The high prevalence of sleep issues during menopause transition and postmenopause has been suggested to contribute to depressive symptoms and to an overall decline in quality of life.<sup>287,288,289</sup> Two longitudinal cohort studies assessed the new onset of depressive symptoms and disorders during the menopausal transition. The Penn Ovarian Aging Study followed over 8 years 436 women with no history of depression and correlated hormonal changes with the onset of depressed mood.<sup>290</sup> Fifty percent of the women developed an increase in measures of depression and 26% met the criteria for a clinical diagnosis of depressive disorder. Using the women as their own controls, the depression group was 2.5 times more likely to develop clinical depression comparing status during the perimenopausal transition to the premenopausal state. These symptoms during the perimenopausal transition were associated with greater variability (but no average differences) in estradiol levels, suggesting that fluctuations of estradiol can be an important destabilizing factor.

The Harvard Study of Moods and Cycles is a prospective cohort of women with and without histories of depression.<sup>291</sup> In the women who entered the menopausal transition, the risk of new depression was almost doubled compared with premenopausal women, from 9.5% to 16.6%, and this risk was linked to the presence of vasomotor symptoms. Importantly, a statistically significant increase in risk of new depressive symptoms was present only in women with a history of adverse life events (the events are not defined or specified in the report). Also of note, 83% of the women experienced no mood changes.

The SWAN study reported similar results. A first episode of depression in perimenopausal women was linked to poor physical health, anxiety disorders, stressful life events, and hot flushing.<sup>292</sup>

Additional studies have shed further light on the role of VMS, sleep disturbances, and depressive symptoms. In a pooled analysis of eight studies from the InterLACE consortium, it was found that sleep difficulties related to VMS explained to a large extent the relationship between VMS and depressed mood.<sup>288</sup> Interestingly, the OR of

depressed mood associated with often/severe vasomotor symptoms was not significant when adjusted for sleep disturbances at baseline.<sup>288</sup> However, having an often/severe depressed mood remained associated with subsequent risk of VMS.<sup>288</sup> Alternatively, using the SWAN cohort, a study by Kravitz et al. noted that while sleep disturbances increase across the menopausal transition, they did not necessarily worsen over time.<sup>293</sup> It is important to note, however, that vasomotor symptoms were significantly associated with the number of sleep disturbances experienced throughout the menopausal transition.<sup>293</sup>

This area of concern has been very difficult to study. Inconsistent results can reflect variations in study designs, selection of subjects, methods used to measure mood, and the definition of menopausal status. **However, the best reports provide reliable evidence of a vulnerable population of women.** Depressive mood changes are influenced by other factors, including body weight, smoking, PMS (discussed in [Chapter 14](#)), employment, and marital status. **PMS during reproductive years is a strong predictor of depressive symptoms arising in the menopausal transition.**

The most important questions are whether truly normal women experience an increase in depression during the menopausal transition and are there subtle or even clinically apparent psychological problems that identify a susceptible subgroup. In a cross-sectional analysis of the SWAN cohort, it was found that only 5% of women were affected with the “triad” of depressed mood, disturbed sleep, and sexual problems, suggesting that perhaps there is in fact a susceptible group of women predisposed to psychological consequences in the menopause.<sup>294</sup> Cohort studies support the argument that there is a vulnerable group of women who are at risk for experiencing new-onset depressive symptoms during the menopausal transition. Existing data are consistent with the idea that fluctuations in reproductive hormone levels, as is particularly prevalent during the menopause transition, are related to mood symptoms; however, it is impossible to know if this is a true cause-and-effect relationship. Until such a cause-and-effect relationship is elucidated, current efforts should focus on identifying and treating menopausal women suffering from sleep disturbances related to vasomotor symptoms. In a pooled analysis of individual participant data from four RCTs assessing the effect of various interventions for insomnia related to vasomotor symptoms, cognitive behavioral therapy (CBT) was most successful in reducing insomnia symptoms.<sup>289</sup> Exercise, venlafaxine, escitalopram, yoga, and estradiol were also effective, but less so when compared to CBT.<sup>289</sup>

**In summary, most women (over 85%) experience the menopausal transition without mood difficulties. Some however are at greater risk of new-onset depressive symptoms, and this is probably enhanced by hormonal variations and vasomotor symptoms. This “vulnerable” population is likely derived from a group**

**of premenopausal women with underlying psychological underpinnings. Although it can be hypothesized that the perimenopausal hormone milieu makes an individual less able to deal with adverse events in life, concrete data to support this concept are lacking.**

Attempts to study the effects of estrogen on these problems have been hampered by the subjectivity of the complaints (high placebo responses) and the “domino effect” of what a reduction of hot flushes does to the frequency of the symptoms. Using a double-blind crossover prospective study format, Campbell and Whitehead concluded many years ago that many symptomatic “improvements” ascribed to estrogen therapy result from relief of hot flushes—a “domino” effect.<sup>295</sup> Studies that have controlled for menopausal symptoms conclude that mood is very affected by vasomotor symptoms and sleep disturbances, besides reflecting life problems.<sup>149,296</sup>

A study of 2,001 Australian women aged 45–55 focused on the utilization of the health care system by women in the perimenopausal period of life.<sup>13</sup> Users of the health care system in this age group were frequent previous users of health care, were less healthy, and had more psychosomatic symptoms and vasomotor reactions. These women were more likely to have had a significant previous adverse health history, including a past history of premenstrual complaints. This study emphasized that perimenopausal women who seek health care help are different from those who do not seek help, and they often embrace hormone therapy in the hope it will solve their problems. Similar findings have been reported in a cohort of British women.<sup>297</sup> It is this population that is seen most often, producing biased opinions among clinicians regarding the menopause. We must be careful not to generalize to the entire female population the behavior experienced by a few. Most importantly, menopausal women who present to clinicians often end up being treated with estrogen inappropriately and unnecessarily. Nevertheless, it is well established that a woman’s quality of life is disrupted by vasomotor symptoms, and estrogen therapy provides impressive improvement.<sup>298,299,300</sup> Patients are grateful to be the recipients of this “domino” effect.

The Women’s Health Initiative (WHI, discussed later under Menopausal Hormone Therapy) concluded that estrogen-progestin therapy had no beneficial impact on health-related quality of life.<sup>301</sup> However, only 12.7% of the participants had moderate to severe vasomotor symptoms at entry to the study, and the symptom burden in this population can be questioned because the participants were willing to take placebo medication. The overall baseline quality of life in this study was relatively high, and the study participants were older (the average number of years distant from menopause was 12+). This randomized, clinical trial did not study the appropriate population of women in order to assess the effect of hormone therapy on measures of quality of life.

The Women’s International Study of Long Duration Oestrogen after the Menopause

(WISDOM) trial was a randomized, controlled trial in the United Kingdom, Australia, and New Zealand of 3,721 women aged 50–69 treated with either combined 0.625 mg conjugated estrogens to 2.5/5.0 mg medroxyprogesterone or placebo.<sup>302</sup> The original plan was to randomize 22,300 women to the study that would last 10 years. The study was canceled in October 2002 in reaction to the initial reports from the WHI. Unfortunately, the premature cancellation precludes the possibility of any long-term data from WISDOM. In 2,130 women who completed 1 year, there were statistically significant improvements in the treated women in the categories of vasomotor, sexual, and sleep symptoms. Treated women reported a reduction in aching joints and muscles, night sweats, insomnia, and vaginal dryness. The treated group reported more breast tenderness, but the percentages were notably low (16% in the treated group and 7% in the placebo group).

The WISDOM trial investigators argued that the small effects on quality of life reported by the WHI and HERS can be attributed to the insensitive measurement tools used in those clinical trials. The WISDOM trial used a survey tool specifically designed to assess postmenopausal physical and emotional well-being, plus a validated, generic questionnaire, the European quality of life instrument. Only the specific questionnaire detected significant changes; the European generic tool did not. This emphasizes the importance of using the appropriate study tool to investigate this area of postmenopausal health. Similar results with vasomotor symptoms, sleep, and joint complaints were actually reported by the WHI, but with a smaller difference between treated and placebo groups. The WHI survey had only one question devoted to sexuality.

The results of the WISDOM trial are not surprising; they reflect what all clinicians have observed in their own practices. The most important point to be made is this: the WISDOM, WHI, and HERS trials were all similar in that they enrolled postmenopausal women heavily tilted toward the oldest age group without symptoms. It is a simple and logical conclusion that hormone therapy in a younger, symptomatic group of postmenopausal women would produce greater quality of life benefits than that quantified in the clinical trials. All three clinical trials, therefore, underestimated the beneficial impact because of age and symptom status of their participants. However, in the WISDOM trial, even older postmenopausal women who were symptomatic benefited from hormone therapy. Age should not be the sole guiding factor in decision-making.

Emotional stability during the perimenopausal period can be disrupted by poor sleep patterns. Hot flushing does have an adverse impact on the quality of sleep.<sup>303,304,305</sup> Estrogen therapy improves the quality of sleep, decreasing the time to onset of sleep and increasing the rapid eye movement (REM) sleep time.<sup>298,306,307</sup> In the SWAN study, one-third of the women reported sleep problems, even without hot flushes or night sweats, and the prevalence of vasomotor symptoms was associated with an

increased risk of sleep disturbances; hormone therapy improved sleep quality.<sup>308,309</sup> Perhaps, flushing may be insufficient to awaken a woman but sufficient to affect the quality of sleep, thereby diminishing the ability to handle the next day's problems and stresses. An improvement in sleeping with estrogen treatment can even be documented in postmenopausal women who are reportedly asymptomatic.<sup>307</sup>

Thus, the overall "quality of life" reported by women can be improved by better sleep and alleviation of hot flushing. However, it is still uncertain whether estrogen treatment has an additional direct pharmacologic antidepressant effect or whether the mood response is totally an indirect benefit of relief from physical symptoms and, consequently, improved sleep. Utilizing various assessment tools for measuring depression, improvements with estrogen treatment were recorded in oophorectomized women.<sup>310,311</sup> In the large prospective cohort study of the Rancho Bernardo retirement community, no benefit could be detected in measures of depression in current users of postmenopausal estrogen compared with untreated women.<sup>312</sup> Indeed, treated women had higher depressive symptom scores, presumably reflecting treatment selection bias; symptomatic and depressed women seek hormone therapy. Others report that estrogen therapy has a more powerful impact on women's well-being beyond the relief of symptoms such as hot flushes.<sup>298,313,314</sup> In elderly depressed women, improvements in response to fluoxetine were enhanced by the addition of estrogen therapy.<sup>315</sup> In a 12-week, randomized, placebo-controlled trial of 55 perimenopausal women with clinically significant major depression, estradiol treatment with the 100 mg transdermal method significantly improved mood.<sup>316</sup> A similar American short-term study of 34 perimenopausal women with both major and minor depressions treated with 50 mg estradiol transdermally demonstrated improvements independently of an effect on vasomotor symptoms.<sup>317</sup> These small clinical trials argue that estrogen treatment is beneficial for the treatment of clinical depression. This conclusion is supported by the successful treatment of postpartum depression with estradiol treatment.<sup>318,319</sup>

**The most common cause of mood problems is already-existing depression,<sup>9,320</sup> but there does exist a small population of women whose moods are sensitive to hormonal changes.** In the American SWAN study, the prevalence of mood changes increased from the premenopause to the early menopause, from about 10% to about 16.5%.<sup>320</sup> There are three possible explanations: (1) the decline in estrogen at menopause affects neurotransmitters that regulate mood; (2) mood is adversely affected by vasomotor symptoms (the domino theory); and (3) mood is affected by the vicissitudes of life that are commonly prevalent around menopause. Some would argue that these mood swings are in response to the hormonal fluctuations that occur during the perimenopausal years. These fluctuations do indeed occur,<sup>67</sup> but whether they cause any symptoms remains to be determined. It seems logical that individuals with mood

problems can reflect all of these mechanisms.

# Cognition and Dementia

Depending on the method of assessment, evidence for beneficial effects of estrogen on cognition can be found in the literature, especially in verbal memory.<sup>321,322</sup> However, the effects in healthy women are not impressive and perhaps of little clinical value. A short-term study failed to document an objective improvement in memory, although a slight improvement in mood was recorded.<sup>323</sup> Another short-term (3 months) randomized, double-blind study could detect no improvement in cognitive performance compared with placebo treatment.<sup>324</sup> The Melbourne Women's Midlife Health Project could not document an effect on verbal memory during the menopausal transition.<sup>325</sup> A longitudinal study in Chicago could not detect a cognitive decline through the menopause, as assessed by working memory and perceptual speed.<sup>326</sup> On the other hand, estrogen treatment of women immediately after bilateral oophorectomy was associated with improvement in certain, but not all, specific tests of memory, and healthy postmenopausal women taking estrogen scored higher on tests of immediate and delayed recall.<sup>327,328,329</sup> In a case-control study of women aged 55–93 years, estrogen users had better recall of proper names, but no improvement in word recall.<sup>330</sup> Women in the Baltimore Longitudinal Study of Aging who were using estrogen performed better in tests of visual learning and memory.<sup>331,332</sup> In a New York City cohort of women, the use of estrogen was associated with better performance in tests of cognition, and better performance in verbal memory, but the cohort in the Study of Osteoporotic Fractures demonstrated no effect of estrogen use on the age-related decline in cognition.<sup>333,334</sup> In Connecticut, a randomized, placebo-controlled trial demonstrated better reading ability and verbal memory in the estrogen-treated group of postmenopausal women.<sup>335</sup> Perhaps, a lack of agreement is due to the variability in test vehicles and the specific aspects of memory function studied. Furthermore, there is impressive individual variability, and when differences have been observed, they have not been large and perhaps of little clinical importance. In addition, any beneficial effects may be attenuated by progestational agents.<sup>322</sup>

Another possibility for the variable effects of estrogen treatment on cognition is the variability among women in endogenous estrogen levels. Using sensitive assays for free, non-protein-bound estradiol and bioavailable (loosely bound) estradiol, cognitive decline occurred at a greater rate in women with low estradiol levels.<sup>336</sup> Studies of cognition may have to differentiate between low- and high-risk women according to endogenous, biologically active estradiol levels. Similarly, a beneficial effect on cognitive decline has been observed only in women negative for the gene associated with Alzheimer disease, APOE- $\epsilon$ 4, which encodes the  $\epsilon$ 4 allele of the glycoprotein known as apolipoprotein E, which has, as one of its functions, the shuttling of lipids

during neuronal repair.<sup>337</sup>

Up to 3 times as many women as men develop Alzheimer disease. Estrogen is capable of protecting central nervous system function by means of multiple mechanisms. For example, estrogen protects against neuronal cytotoxicity induced by oxidation; estrogen reduces the serum concentration of amyloid P component (the glycoprotein found in Alzheimer amyloid plaques); and estrogen increases synapses and neuronal growth, especially dendritic spine density.<sup>338,339,340</sup> Estrogen protects against the cerebrovascular toxicity exerted by amyloid peptides and promotes synaptic formation and neuronal growth and survival.<sup>341,342,343</sup> Progestational agents do not exert similar actions.

Case-control and cohort findings indicated that Alzheimer disease and related dementia occurred less frequently (perhaps as much as 60% less) in estrogen users, and the effect was greater with increasing dose and duration of use.<sup>344,345,346</sup> In the Baltimore Longitudinal Study of Aging (a prospective cohort), the risk of Alzheimer disease was 54% reduced; in a cohort in New York City, the risk was reduced 60%; and in the Italian Longitudinal Study of Aging, the risk was 72% reduced in estrogen users.<sup>347,348,349</sup> The findings are not uniformly positive; a case-control study with accurate information on clinical diagnoses and estrogen use from the U.K. General Practice Research Database could detect no impact of estrogen treatment on the risk of developing Alzheimer disease, but the number of estrogen users was very small.<sup>350</sup>

The short-term administration of unopposed estrogen to patients with Alzheimer disease (secondary prevention) has been reported to improve cognitive performance, but mostly to have no effect.<sup>351,352,353,354,355</sup> The administration of combinations of estrogen and progestin has also failed to demonstrate a beneficial impact in Alzheimer disease.<sup>356</sup> The presence of estrogen therapy has been reported to enhance the beneficial response to tacrine in women with Alzheimer disease,<sup>357</sup> but overall, the evidence is consistent with a failure of estrogen to influence already-existing Alzheimer disease or other forms of dementia.<sup>358</sup>

**The data do support, however, a primary preventive effect.** Most revealing is a prospective cohort study of women living in Cache County, Utah.<sup>359</sup> Hormone therapy provided about a 41% reduced risk of developing Alzheimer with any use and an 83% reduction with 10 or more years of use. This cohort also demonstrated improved cognition in estrogen users.<sup>360</sup> Most importantly, if women had initiated hormone therapy within a period of time that encompassed 10 years before the development of clinical symptoms, there was no effect. The Utah study strongly suggested that hormone therapy must be used for a significant duration of time very early in the postmenopausal period in order to have an impact on the risk of Alzheimer disease. As neurons become



changed by the pathology of dementia, they lose their ability to respond favorably to estrogen.<sup>293</sup>

The importance of timing is supported by findings from the large WHI clinical trial. The oldest women in the WHI being treated with either estrogen alone or combined estrogen-progestin (treatment began at age 65 or older) had impaired cognition and an increased risk of dementia.<sup>361,362,363</sup> In a subset of these women, MRI scans demonstrated greater brain atrophy in the women receiving hormone therapy.<sup>364</sup> The mechanism for this adverse effect of hormonal therapy in old women may be a neurotoxic action because the WHI study with MRI scanning could not detect an increase in ischemic brain lesions.<sup>365</sup> Smaller MRI studies of younger women treated with hormone therapy found beneficial trophic changes in brain morphology, associated with improved cognition.<sup>366,367,368</sup> The KEEPS-Cognitive and Affective Study was an ancillary study to the KEEPS, a randomized, double-blind, placebo-controlled trial of menopausal hormone therapy (further discussed later in this chapter under the section on Menopausal Hormone Therapy). While the parent study examined the timing hypothesis from the perspective of cardiovascular disease, the ancillary study examined the timing hypothesis from the perspective of cognition and mood.<sup>369</sup> In KEEPS, postmenopausal women within 3 years of the last menstrual period were randomized to oral versus transdermal estrogen versus placebo. Over a 4-year intervention period, 220 women received daily 0.45 mg oral conjugated equine estrogens (o-CEEs), 211 women received 50 µg/day transdermal estradiol (t-E2), and 262 women were assigned to placebo pills and patches. Women assigned to oral and transdermal estrogen additionally received micronized progesterone 200 mg/day for the first 12 days of each month. The primary outcomes for the Cognitive and Affective ancillary study included the Modified Mini-Mental State Examination, verbal learning/memory, auditory attention/working memory, visual attention/executive function, and speeded language/mental flexibility, and a mood measure (Profile of Mood States).<sup>369</sup> The KEEPS cognitive study failed to demonstrate any neuroprotective effects of menopausal hormone therapy on the studied cognitive outcomes. However, improvement in mood parameters (tension-anxiety, depression-dejection, anger-hostility, fatigue, vigor, and confusion-bewilderment) was observed in the subgroup of women assigned to o-CEE.<sup>369</sup> In a subsample of KEEPS subjects, the effect of hormone therapy on beta-amyloid protein deposition was studied using positron emission tomography (PET) scan. Of the 112 KEEPS eligible participants, 61 women with a median age of 60 were included in the analysis. While there were no differences in baseline characteristics of the subjects, carriers of the apolipoprotein e4 allele (a known risk factor for developing Alzheimer disease) who were assigned to transdermal estradiol arm of the clinical trial had evidence of reduced beta-amyloid protein deposition on PET scan.<sup>370</sup> While the

sample size is small, KEEPS data suggest that effects of estrogen on the brain may differ by route and formulation of hormone regimen.<sup>370</sup>

**The theme that emerges is that maintenance of health in target organs by estrogen requires normal tissue, a principle of timing that will also be discussed in regard to the heart later in this chapter under the section on Menopausal Hormone Therapy. Following the failure of secondary prevention trials to demonstrate a beneficial impact of hormone therapy on coronary disease in older women, it is increasingly argued that healthy cardiovascular endothelium is needed to respond to estrogen; that by the time, the endothelium is involved with excessive atherosclerosis, it is too late for estrogen to exert a beneficial effect. A similar argument is made for brain tissue, focusing on biochemical and signaling pathways that are progressively compromised with the neuronal involvement with disease.<sup>371</sup> The requirement for normal tissue, at least in the heart and in the brain, would explain the beneficial effects in studies of primary prevention and the lack of effect in secondary prevention trials.**

# CARDIOVASCULAR DISEASE

---

Diseases of the heart are the leading cause of death for women in the United States, followed by cerebrovascular disease and malignant neoplasms. In 2016, one in four female deaths were from CHD compared with one in eight women who develop breast cancer.<sup>372</sup> More female deaths in 2016 were caused by cardiovascular diseases than the combined total from cancer, chronic lower respiratory disease, Alzheimer disease, accidents, and diabetes mellitus.

Most cardiovascular disease results from atherosclerosis in major vessels. The risk factors are the same for men and women: family history of cardiovascular disease, high blood pressure, smoking, diabetes mellitus, an abnormal cholesterol/lipoprotein profile (Table 17.6), and obesity. However, when controlling for these risk factors, men prior to age 40 have a risk of developing CHD twice that of women. With increasing age, this advantage is gradually lost, and cardiovascular disease becomes the leading cause of death for both older women and older men.

Cardiovascular disease, especially atherosclerosis, is a consequence of multiple metabolic changes that interact with each other:

## TABLE 17.6 The Optimal Cholesterol/ Lipoprotein Profile

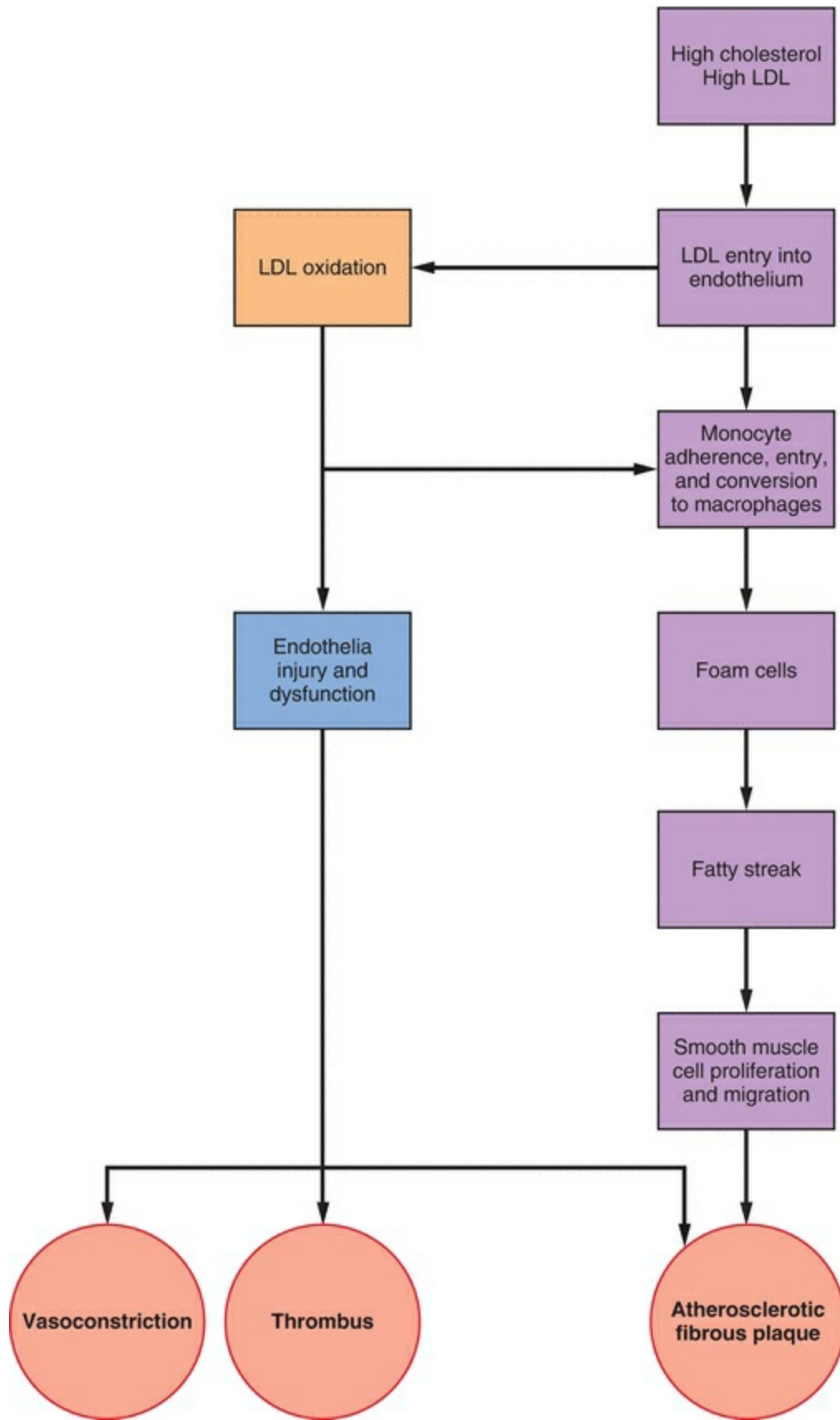
Total cholesterol	<200 mg/dL
HDL cholesterol	>50 mg/dL
LDL cholesterol	<100 mg/dL
Triglycerides	<150 mg/dL

- Adverse changes in the circulating lipid-lipoprotein profile.
- Oxidation of low-density lipoprotein (LDL), producing a modified LDL that is chemotactic for circulating monocytes and inhibits macrophage motility (thus trapping macrophages in the intima) and that causes cell injury and death in the endothelium.
- Endothelial injury and dysfunction affecting nitric oxide and prostacyclin production.
- Macrophage migration and functions, influenced by growth factors and cytokines.
- Proliferation and migration of smooth muscle cells, also influenced by growth factors and cytokines; these cells become the dominant cell type and the source of the connective tissue matrix in the atherosclerotic lesion, the fibrous plaque.
- Vasoconstriction and thrombogenic events.
- Remodeling of coronary arteries. An artery is able to respond to a developing atherosclerotic plaque by increasing its overall diameter in an attempt to maintain flow.<sup>373</sup>

The mechanism of this adaptive remodeling is not known, but the extent of this process must affect the risk of occlusion and infarction.

There is an established sequence of events leading to atherosclerosis (**Figure 17.10**). The process starts with endothelial dysfunction that leads to the fatty streak in arterial vessels, the precursor to clinically significant lesions. The fatty streak lesion, therefore, antedates the fibrous plaque, developing under the endothelial surface and dominated by fat-laden macrophages (the foam cells). The damaged endothelium expresses cytokines, adhesion molecules, and other inflammatory agents that are involved in the formation of atherosclerotic plaques. The formation of a plaque is initiated by the aggregation and adherence of circulating monocytes (macrophages) to a site on the arterial endothelium, stimulating an inflammatory response. When the

monocytes penetrate through the endothelium and enter the intima, they become loaded with lipids and converted to foam cells. Modification of LDL, especially oxidation, is crucial in this conversion of monocytes to foam cells. The adherence of monocytes to endothelium can be induced by elevated cholesterol and LDL cholesterol in the circulation. Most of the cholesterol that accumulates in atherosclerotic plaques is derived from circulating LDL cholesterol. As plaques become significant in size, they are prone to instability, rupturing, and creating a prothrombotic state. Matrix metalloproteinase enzymes are secreted by inflammatory cells and smooth muscle cells. These enzymes digest the proteins in the fibrous cap of an atherosclerotic plaque, making the plaque unstable and predisposed to rupture. **Estrogen induces matrix metalloproteinase production or activity, which digests the fibrous cap of a plaque exposing the underlying thrombogenic collagen, and this is believed to be the mechanism involved in the adverse thrombotic effects of estrogen in the presence of established atherosclerosis.**<sup>374</sup> In addition, 27-hydroxycholesterol, a cholesterol metabolite elevated in atherosclerotic lesions, competitively antagonizes estrogen receptor activity in cardiovascular epithelium.<sup>375</sup>



**FIGURE 17.10**

During the reproductive years, women are “protected” from CHD. For this reason, women lag behind men in the incidence of CHD by 10 years, and for myocardial infarction and sudden death, women have a 20-year advantage. The reasons for this are complex, but a significant contribution to this protection can be assigned to the higher high-density lipoprotein (HDL) levels in younger women, an effect of estrogen and lower levels of testosterone. Throughout adulthood, the blood HDL cholesterol level is about 10 mg/dL higher in women, and this difference continues through the postmenopausal years. Total and LDL cholesterol levels are lower in premenopausal women than in men, although the levels gradually increase with aging and after menopause they rise rapidly.<sup>376,377,378,379,380</sup> After menopause, the risk of CHD doubles for women as the atherogenic lipids at about age 60 reach levels greater than those in men. These changes can be favorably reduced by dietary modifications.<sup>381,382</sup> Of course, these lipid changes at menopause (whether natural or surgical) can be reversed with estrogen treatment.<sup>383</sup>

Prospective studies have documented the strong association between total cholesterol and CHD in women, although CHD risk appears at higher total cholesterol levels for women than for men.<sup>384,385</sup> Women with total cholesterol concentrations greater than 265 mg/dL have rates of CHD 3 times that of women with low levels. Even in elderly women, a high total cholesterol remains a significant predictor of heart disease, but the strength of the association between the cholesterol level and cardiovascular disease decreases with aging, and by age 80, the cost and benefits may not justify cholesterol intervention.<sup>386</sup> This is the reason for ceasing lipoprotein screening after age 75 in patients with normal lipids. However, this decision should be individualized, taking into account the vigor and health of the patient.

The strongest predictor of CHD in women is a low HDL cholesterol.<sup>384,385,387</sup> The average HDL cholesterol in women is approximately 55–60 mg/dL. A decrease in HDL cholesterol of 10 mg/dL increases CHD risk by 40–50%. In women (and men) who had normal total cholesterol and LDL cholesterol levels, but low HDL cholesterol levels, treatment with lovastatin reduced the risk of an acute major coronary event by approximately 37%.<sup>388</sup> High HDL cholesterol levels are uncommon in women with CHD, but even women with high levels do develop CHD.<sup>389</sup> **Because of the increased risk of CHD observed in individuals with low HDL, it is appropriate to be concerned when HDL cholesterol levels are less than 50 mg/dL.** It should be emphasized that modest elevations in blood pressure markedly increase the overall cardiovascular risk associated with an elevated LDL cholesterol or a low HDL cholesterol.

Keep in mind that low HDL cholesterol levels are a component of the metabolic syndrome related to insulin resistance. The metabolic syndrome is partly a result of

heredity but is also strongly influenced by obesity and physical inactivity. In the United States, the overall estimated prevalence of the metabolic syndrome is 24%, higher in women (40% by age 60) and increasing with age.<sup>390</sup> The prevalence increases with increasing body weight, from about 5% in normal-weight individuals to 60% in obese men and women, and the prevalence is highest in Mexican Americans and lowest in Blacks.<sup>391</sup>



# Metabolic Syndrome and Cardiovascular Disease

As defined by the National Heart, Lung, and Blood Institute and the American Heart Association, a diagnosis of metabolic syndrome requires the presence of any three of the following five clinical characteristics<sup>392</sup>:

1. Increased waist circumference (population specific, >88 cm for women in the United States)
2. Increased blood pressure ( $\geq 130$  mm Hg systolic;  $\geq 85$  mm Hg diastolic) or receiving medication for hypertension
3. Increased triglycerides ( $\geq 150$  mg/dL) or receiving medication for hypertriglyceridemia
4. Decreased HDL cholesterol ( $< 50$  mg/dL) or receiving medication for reduced HDL
5. Increased fasting glucose ( $\geq 100$  mg/dL) or receiving medication for hyperglycemia

An increasing prevalence of metabolic syndrome during the menopausal transition is correlated with increasing androgen dominance, as estrogen secretion declines.<sup>393,394</sup> Adiposity of the trunk is a risk factor for CHD in women and is associated with a relatively androgenic hormonal state, as well as hypertension, and disorders of lipid and carbohydrate metabolism.<sup>395</sup> Central fat distribution in women is positively correlated with increases in total cholesterol, triglycerides, and LDL cholesterol and negatively correlated with HDL cholesterol.<sup>396</sup> The atherogenic lipid profile associated with abdominal adiposity is at least partly mediated through an interplay with insulin and estrogen.<sup>397</sup> It is worth noting that there is a strong correlation between the magnitude of the worsening in cardiovascular risk factors (lipid and lipoprotein changes, blood pressure, and insulin levels) and the amount of weight gained during the menopausal transition.<sup>398</sup> Attention to weight gain during middle age is one of the most important components of good preventive health care. However, **weight gain at menopause is not an effect of hormonal changes, but rather it reflects aging-related alterations in lifestyle such as changes in diet and exercise that accompany aging.**<sup>398</sup>

Current recommendations regarding the optimal cholesterol/lipoprotein profile are more aggressive, urging more intensive treatment aimed at lowering LDL cholesterol levels; in the presence of CHD, the goal is to lower LDL cholesterol to less than 100 mg/dL.<sup>399</sup> Cholesterol-lowering drugs, specifically the statin family, have been repeatedly demonstrated in clinical trials to have a marked reduction in the risk of

clinical cardiovascular events in both men and women.<sup>400,401</sup>

Triglycerides are also an important risk factor for CHD in women, but are most commonly encountered in individuals with the metabolic syndrome.<sup>399</sup> If the triglyceride level is greater than 400 mg/dL and the HDL cholesterol is less than 50 mg/dL, the risk of heart disease is substantially increased. Patients with an elevated triglyceride level and a positive family history for heart disease most likely have an autosomal dominant disorder classified as familial combined hyperlipidemia. This disorder accounts for most myocardial infarctions in women less than 40 years old. Triglyceride levels of 150–200 mg/dL are considered borderline elevated. Triglyceride levels can be elevated because of obesity, smoking, and lack of exercise. Weight loss alone can return elevated triglyceride levels to normal.

Observational studies and clinical trials indicate that the major determinants of blood lipid levels are the same for both sexes. A diet high in saturated fatty acids and dietary cholesterol unfavorably increases blood lipids. Excess caloric intake and obesity decrease HDL cholesterol and increase total cholesterol, LDL cholesterol, and triglycerides. Smoking decreases HDL cholesterol (and also produces lower estrogen levels and an earlier menopause). Genetic defects of receptor-mediated cholesterol uptake account for only a small percentage of hyperlipidemia in men and women. There is also evidence that men and women who had impaired fetal growth have increased levels of cholesterol and LDL cholesterol in middle age.<sup>402</sup> The speculation is that impaired liver growth in utero produces a permanent adverse change in cholesterol and lipoprotein metabolism. Reduced fetal growth also leads in adulthood to insulin resistance and lower HDL cholesterol levels, most severe in those who become obese.<sup>403</sup>

# C-Reactive Protein and Cardiovascular Disease

The immune system (monocytes, cytokines, and cell adhesion molecules) and inflammatory processes both play an active role in the process of atherosclerosis.<sup>404</sup> Studies indicate that C-reactive protein (CRP) is a marker of cardiovascular risk in both men and women.<sup>405,406,407</sup> This risk is limited, however, to arterial disease; CRP levels are not linked to venous thrombosis or pulmonary embolus.<sup>405</sup> CRP predicts an increased risk of cardiovascular events even in individuals who have normal lipid levels, and, therefore, it is argued that both CRP and lipid profiles should be used for screening purposes.<sup>407,408</sup>

CRP is a protein synthesized in the liver and atherosclerotic arteries and was given its name because it reacts with the C-polysaccharide of *Streptococcus pneumoniae*. Thus, the circulating level of CRP increases in response to various inflammatory stimuli, but specifically bacterial infections and chronic inflammatory conditions such as systemic lupus erythematosus (SLE). Sensitive assays now detect small increases associated with low-grade inflammation in the vascular system.

Increased levels of CRP in patients with angina predict poor outcome, an increase in the relative risk of a coronary event. Prospective studies have documented an increased risk of cardiovascular events in patients without known cardiovascular disease who have high CRP levels, an association that is even greater in smokers.<sup>409</sup> Higher mean levels are found in both men and women who subsequently have myocardial infarctions. Stroke and peripheral vascular disease are also increased in men with higher CRP levels, and in women, CRP is also elevated in stroke.<sup>410</sup> In a meta-analysis of 14 prospective studies, individuals with CRP levels in the top third compared with individuals in the bottom third had a twofold increase in relative risk for CHD.<sup>411</sup> Thus, CRP levels have predictive value in both healthy individuals and individuals with cardiac disease. In addition, statin treatment lowers CRP levels,<sup>412</sup> and evidence indicates that statins and aspirin achieve greater benefits in individuals with high CRP levels.<sup>405,413</sup>

In general, studies have indicated that oral estrogen treatment (with or without progestin) increases CRP levels and raloxifene does not. In a double-blind, randomized trial, menopausal hormone therapy and raloxifene equally lowered homocysteine levels (a marker for vascular risk), but estrogen-progestin treatment increased CRP levels, whereas raloxifene had no effect.<sup>414</sup> These results were duplicated in a Dutch randomized study.<sup>415</sup> Tibolone (discussed later in this chapter under the section on Menopausal Hormone Therapy) increases CRP levels to the same degree as oral estrogen therapy.<sup>416</sup> A cross-sectional study found higher levels of CRP in healthy

postmenopausal women using hormone therapy.<sup>417</sup> In the PEPI randomized trial, hormone therapy increased CRP levels, but the levels of E-selectin, another marker of inflammation, were reduced.<sup>418</sup>

An estrogen-induced increase in CRP levels may be due to the known stimulant effects of estrogen on hepatic synthesis of proteins, especially because of the first-pass phenomenon with oral administration. For this reason, transdermal estrogen treatment does not change CRP levels.<sup>416,419,420</sup> Studies on multiple inflammatory markers report that oral estrogen therapy increases only CRP, the only marker synthesized in the liver. In fact, oral hormone therapy while increasing CRP reduces the circulating levels of other inflammatory markers (E-selectin, intercellular adhesion molecule-1, vascular cell adhesion molecule-1, monocyte chemoattractant protein-1, and tumor necrosis factor- $\alpha$ ) with inconsistent effects on interleukin-6 (IL-6).<sup>421,422</sup> Most importantly, it is not certain that the decrease in CRP levels with statins and the increase with estrogen are actually instrumental in clinical outcomes or reflect other effects. Thus, raising or lowering CRP levels will not necessarily increase and decrease the risk of clinical disease. A study from the WHI confirmed the correlation between baseline levels of CRP and an elevated risk of CHD, **but the increase in CRP induced by oral hormone therapy did not further increase this risk!**<sup>423</sup> **The uncertainties and questions regarding the clinical relevance of CRP levels make it premature to conclude that changes in CRP levels with hormone therapy have any direct clinical consequence. This does not detract, however, from the utility of CRP levels in quantifying the overall risk of cardiovascular disease in an individual patient.**

# Homocysteine and Cardiovascular Disease

Hyperhomocysteinemia is associated with an increase in risk for CHD.<sup>407</sup> Increasing folic acid intake and hormone therapy both reduce the circulating levels of homocysteine. In the WHI observation study, assessment of inflammation and hemostasis biomarkers for predicting stroke was undertaken in postmenopausal women, and homocysteine was not found to be of any value as a predictive biomarker in this population.<sup>410</sup> **The value of homocysteine measurements in a screening program and the efficacy of therapy directed to lowering homocysteine levels remain to be determined.**

# Lipoprotein(a) and Cardiovascular Disease

Lp(a) is composed of two parts, a lipoprotein particle that is similar to LDL and a glycoprotein component that resembles a clotting protein. Lp(a) is an independent risk factor for CHD. Menopausal hormone therapy has been associated with reduction in circulating Lp(a) levels.<sup>424</sup> Unlike other markers, the levels of Lp(a) are unaffected by lifestyle, and no clinical use has been established for Lp(a) measurements.

# Sex Steroids and Cardiovascular Disease

By a large margin, the leading cause of death among women continues to be CHD. Coronary atherosclerosis is a lifelong process that varies in its slope of development according to the presence or absence of risk factors. The landmark Pathobiological Determinants of Atherosclerosis in Youth (PDAY) study documented the presence of fatty streaks in adolescents and an increasing prevalence with increasing age.<sup>425</sup> The PDAY study further established that abnormal lipid profiles early in life are a major factor in determining the extent and age of onset of atherosclerosis.<sup>426</sup> It is important for clinicians caring for women to appreciate the importance of premenopausal atherosclerosis and to understand that appropriate medical interventions can reduce the risk of later clinical events. Because atherosclerosis begins early in life, it is logical to conclude that the postmenopausal risk of coronary clinical events is influenced by the degree of coronary artery atherosclerosis already present at the time of menopause.

Women with POI (older terminology is “premature ovarian failure or POF”) are at increased risk for cardiovascular disease.<sup>427</sup> In other words, there is an inverse relationship between the risk of cardiovascular disease and the age of menopause.<sup>428</sup> Endothelial function in women with POI is impaired, as measured by dilation of the brachial artery in response to blood flow, a response known to be mediated by estrogen-modulated endothelial nitric oxide.<sup>429,430</sup> This association between endothelial dysfunction and hypoestrogenemia is reinforced by the observation that endothelial dysfunction in women with POF was improved by hormone therapy.<sup>429</sup>

An important contribution to the gender difference in cardiovascular disease prevalence and age of onset is the favorable effect of estrogen on important endothelial events. Vasodilatory and antithrombotic activities can be attributed to endothelial production of nitric oxide and prostacyclin, a process favorably influenced by estrogen. Hypercholesterolemia adversely affects this important endothelial process, and estrogen protects this important endothelial function in the presence of hypercholesterolemia.<sup>431</sup> Estrogen inhibits the oxidation of LDL and also protects against the toxic effects of oxidized LDL on the endothelium. Women in the SWAN study who complained of hot flushing had more evidence of subclinical cardiovascular disease, such as aortic calcification, compared to those without hot flushes.<sup>432</sup>

A Chinese comparison study concluded that Chinese men and women with angiographically determined coronary artery disease differ in the circulating sex steroid hormone milieu, compared with age-matched healthy individuals.<sup>433</sup> Straightforward reasoning has led investigators to connect the different prevalence of coronary artery disease in men and women to the obvious differences in circulating sex steroids determined by the testicles and ovaries. The newly appreciated importance of estrogen

in the premenopausal years has added strength to this connection. For many years, it has been generally believed that higher estrogen exposure in women protects against coronary artery disease, and the difference in coronary artery disease prevalence between men and women diminishes after menopause because of the loss of estrogen. At the heart of the matter is the gonadal difference between men and women.

Acute coronary events in premenopausal women occur more frequently when estrogen levels are the lowest during the menstrual cycle.<sup>434</sup> In the national SWAN study, cardiovascular risk factors were more favorable in women with higher levels of estrogen and less favorable in women with longer menstrual cycles.<sup>435</sup> Even amenorrheic athletes in good physical condition have demonstrated endothelial dysfunction, a condition that responded favorably to estrogen-containing oral contraceptives.<sup>436,437</sup>

In the WISE (Women's Ischemia Syndrome Evaluation) study, a study of premenopausal women undergoing coronary angiography for suspected myocardial infarction, coronary artery disease was more prevalent in those women who had low estrogen levels because of hypothalamic suppression.<sup>438</sup> These findings are similar to the pioneering studies in monkeys that demonstrated acceleration of atherosclerosis in animals with low estrogen because of stress-induced hypothalamic suppression, an effect that could be prevented by oral contraceptive treatment.<sup>439,440,441</sup> Postmenopausal women studied with coronary angiography in the WISE study who had used oral contraceptives in the past had less coronary artery disease.<sup>442</sup> In addition, premenopausal women with coronary artery disease have lower circulating levels of estrogen compared with normal women.<sup>443</sup>

Depression is a recognized risk factor for heart disease, but its contribution to premenopausal atherosclerosis is just beginning to be appreciated. Premenopausal monkeys that exhibit depressive behavior (induced by their lower social rank in a colony of animals) develop a more adverse lipid profile and an increasing degree of atherosclerosis when fed atherogenic diets.<sup>444</sup> Premenopausal women with a history of recurrent depression and without known coronary disease are more likely to have coronary and aortic calcification, a marker for early atherosclerosis.<sup>445</sup> The SWAN study found more aortic calcification in black women with depressive symptoms, although an association between coronary calcification and depression in black or white women could not be detected.<sup>446</sup>

Thus, hypoestrogenemia in the premenopausal years, whatever the cause, can increase the progression of atherosclerosis. This would include suppressed ovarian function associated with stress, depression, or intense athletic activity. The progressively deleterious effects of hypoestrogenemia include endothelial dysfunction,



lower levels of HDL cholesterol, an increase in central obesity, and possibly depression. **In monkeys and in women, lipid effects account for only 25–30% of the atheroprotective effects of estrogen.**<sup>447,448</sup>

A vast literature has documented multiple mechanisms favorably influenced by estrogen that would inhibit the development of atherosclerosis.<sup>449</sup> Clinicians tend to view testosterone as an estrogen opponent, and this is supported, for example, by studies such as lipid responses to testosterone that move in the opposite directions to those of estrogen.<sup>450</sup> Both beneficial and detrimental vascular actions of testosterone have been described in in vitro and animal studies. Clinical studies in women have in general supported an association between hyperandrogenism and an increase in risk for cardiovascular disease. The lipid and lipoprotein profile in androgenized women with polycystic ovaries (who are also exposed to relatively lower estrogen levels over time) is similar to the male pattern with higher levels of cholesterol, triglycerides, and LDL cholesterol and lower levels of HDL cholesterol, and this abnormal pattern is independent of body weight.<sup>451,452,453,454,455</sup> An adverse lipid and lipoprotein profile is a distinguishing feature of these patients even when body mass index (BMI), insulin, and age are controlled in case-control studies.<sup>456</sup> Subclinical atherosclerosis can be demonstrated by carotid ultrasonography to be prevalent in premenopausal women with a history of anovulation and polycystic ovaries.<sup>457</sup> In women undergoing coronary angiography, the prevalence of polycystic ovaries is increased, and women with polycystic ovaries have more extensive coronary atherosclerosis.<sup>458</sup> In the Nurses' Health Study, women with very irregular cycles compared to women with regular cycles had an adjusted increased risk of CHD.<sup>459</sup> **Thus, anovulatory women with polycystic ovaries develop risk factors for atherosclerosis and ultimately clinical disease comparable with that found in older postmenopausal women.**

Given the variability in circulating sex steroid levels between individuals, between sexes, and within individuals, we should not be surprised that random blood sampling does not always document meaningful differences in blood levels of gonadal steroids in men and women with coronary artery disease. Nevertheless, some cross-sectional studies have documented lower circulating testosterone levels in men with coronary artery disease and higher levels in men with a reduced risk of metabolic syndrome.<sup>460,461</sup> A prospective cohort study determined that lower testosterone levels were associated with an increased risk of developing metabolic syndrome in men.<sup>462</sup> Men with heart failure demonstrate improvements in symptoms and functional capacity when treated with testosterone.<sup>463</sup>

In healthy postmenopausal women, higher androgen levels are associated with increased metabolic markers for the risk of coronary artery disease, and increasing

testosterone levels during the perimenopausal transition correlated with an increasing prevalence of metabolic syndrome in the SWAN study.<sup>393,464,465</sup> Higher testosterone levels, although still in the normal range, have also been found to correlate with a reduction in atherosclerosis progression in naturally postmenopausal women.<sup>466,467</sup>

**In summary, existing data suggest that higher testosterone levels within the normal physiologic range may be protective against atherosclerosis (perhaps by target tissue aromatization to estrogens), whereas elevated androgen levels above the normal range, such as in anovulatory women with polycystic ovaries, are atherogenic.**

The important studies in women and monkeys reviewed above indicate that there exists an innate trajectory of atherosclerosis for each individual that can be modulated by various risk factors and that the slope of this process determines the age of onset for clinical events.<sup>468</sup> The contribution of premenopausal atherosclerosis to the development of clinical events highlights the important role for clinicians in aggressively promoting preventive interventions that can favorably change the slope of progression of atherosclerosis. An important risk factor is exposure to protective levels of estrogen at all stages of life. Conditions associated with hypoestrogenemia during the premenopausal years, therefore, require evaluation and treatment. There are many causes of hypoestrogenemia, and the treatments will vary according to the etiology. When indicated, appropriate hormone treatment can reduce the risk of cardiovascular disease later in life. In addition, appropriate interventions in insulin-resistant women with the metabolic abnormalities associated with polycystic ovaries can reduce the risks of both cardiovascular disease and diabetes mellitus.

A logical continuum of this reasoning is that hormone therapy in the early postmenopausal years likewise can provide primary prevention of clinical coronary disease. **The “timing hypothesis” proposes that adequate estrogen exposure prior to the onset of clinical events provides protection against cardiovascular disease (discussed in further detail under the section on Menopause Hormone Therapy).** A meta-analysis of 23 randomized hormone therapy trials concluded that treatment reduced the risk of CHD events in younger women compared with older women (10 or more years since menopause or >60 years of age).<sup>469</sup> This is a conclusion that is less firm now than when first proposed, because most of these trials were not designed to measure an endpoint of cardiovascular disease. However, another meta-analysis by the same authors concluded that hormone therapy reduced overall mortality in women with an average age of less than 60.<sup>470</sup>

## Cardiovascular Disease: Concluding Thoughts

In the last 30 years, mortality from CHD has declined substantially in the United States. Improvements in medical and surgical care can account for some of this decline, but 60–70% of the improvement is due to timely implementation of preventive measures. Excellent data from epidemiologic studies and clinical trials demonstrate substantial contributions from strategies such as smoking cessation, blood pressure reduction, and lowering of cholesterol toward a documented decline in stroke and heart disease–related morbidity and mortality.<sup>471,472,473</sup> The most effective means to lower CHD in a population is through primary prevention, especially smoking cessation and body weight reduction. While physiologic levels of estrogen are clearly relevant for maintenance of cardiovascular health, however, the impact of exogenous estrogen on cardiovascular risk in aging postmenopausal women who are remote from the FMP is not clearly delineated.<sup>474</sup> When attempting to understand the role of estrogens on cardiovascular risk, it is important to distinguish between endogenous and exogenous estrogens. In addition, more recent work has begun assessing the role of additional reproductive hormones (i.e., FSH) as well as the relevance of vasomotor instability in itself as predictors of cardiovascular risk.<sup>474</sup> While the loss of premenopausal estradiol levels is felt to contribute to the escalation in cardiovascular disease in postmenopausal years, the bulk of existing clinical data are “associative.” Appropriately designed studies are needed to better understand the spectrum of players (hormonal and nonhormonal) that may be relevant as causative to the processes that result in risk escalation for cardiovascular disease as women progress along the stages of reproductive aging.<sup>474</sup>

# MENOPAUSAL HORMONE THERAPY

---

There is little question that estrogen is the most effective of available remedies for women who suffer from bothersome vasomotor symptoms such as hot flashes and night sweats or from consequences of atrophy of reproductive tract tissues that naturally follows cessation of ovarian function; these benefits of estrogens have been long recognized. In the 1990s, however, based on accruing observational studies and a rationale that was driven by biologic plausibility, the focus of postmenopausal hormone therapy changed from short-term use in the management of symptom burden to long-term utilization as a preventative strategy against common diseases and disorders of aging including cardiovascular disease, dementia, and osteoporosis. HT was found to be very effective in treating vasomotor symptoms. Similarly, skeletal benefits in preventing osteoporosis were also clear. However, long-term use of HT for the sole purpose of targeting cardiovascular disease and dementia was challenged by a sequence of seminal clinical trial, with WHI being at the forefront. Not only did the clinical trial data indicate that HT did not protect against cardiovascular disease, nor mitigate the risk of aging-related dementia, but, on the contrary, raised concerns regarding the potential for harm as evident in an increased risk of thrombotic phenomenon, stroke, and breast cancer. In WHIMS (Women's Health Initiative Memory Study), incidence of cognitive deterioration was higher in the hormone-using postmenopausal women compared to those assigned to placebo. The ensuing decades following publication of WHI findings witnessed passionate and widespread quests attempting to unravel potential mechanisms that could explain HT-related harm; for a brief period, the field of menopause was rendered complex and decision-making by clinicians and patients very difficult. In this section of the chapter, we offer a comprehensive review of the literature, including more recent data and analyses, to help serve as a guide for the practicing clinician caring for menopausal women.

# History<sup>475,476,477,478</sup>

The existence of hormones was unknown 200 years ago. In the last half of the 19th century, a scattering of chemists and physiologists began to produce hormonally active extracts from glands, bile, and urine of animals. Adventurous clinicians used these extracts to treat patients, for example, supplying thyroid hormone to treat severely hypothyroid individuals, and the specialty of endocrinology was born. The word “endocrine” was adopted to designate the “glands of internal secretion,” the multiple sources of hormones.

Charles-Édouard Brown-Séquard, the son of a French woman and an American sea captain, was born on the island of Mauritius. Speaking fluent English and French, he practiced medicine and lectured in London and New York before settling in Paris. Brown-Séquard reported in 1889 that he was rejuvenated by the self-administration of extracts from dog testicles, most likely a placebo effect considering the scant amount of testosterone he could have extracted using his aqueous method, and he suggested that ovarian extracts would have the same revitalizing effect in women. Efforts to treat women around the end of the 19th century were largely unsuccessful, but in 1897, ovarian extract was reported to be effective for menopausal hot flushing.<sup>479</sup>

The first American attempt to treat menopausal symptoms is attributed to E.L. Severinghaus and J. Evans of Madison, Wisconsin, who in 1929 administered a derivative from the amniotic fluid of cattle.<sup>476,480</sup> In the 1930s, the ovarian hormones were isolated, and the “estrin” products and the synthetic estrogens, stilbestrol and ethinyl estradiol, were administered to menopausal women. Edgar Allen and Edward Doisy were the first to isolate the ovarian hormone, estrogen. Allen was born in Colorado, educated at Brown University, and served in France during World War I. In 1933, he became the chairman of the Department of Anatomy at Yale University. He died of a heart attack while on patrol off Long Island for the U.S. Coast Guard in February 1943. Doisy was born in Illinois and educated at the University of Illinois and Harvard. During World War I, he was assigned to the Rockefeller Institute in New York City and then to the Walter Reed Hospital in Washington. Doisy was the first chairman of biochemistry at the St. Louis University School of Medicine. He received the Nobel Prize in Medicine, along with Henrik Dam, in 1943 for his isolation and synthesis of vitamin K. Doisy died in 1986 at the age of 92.

In 1919, Allen and Doisy, both discharged from the army after World War I, joined the faculty at the Washington University School of Medicine in St. Louis. They became friends playing on a faculty baseball team and planned their first experiments while driving to work together. In 1922, Allen moved to the University of Missouri to be professor of anatomy, and Doisy went to St. Louis University, but they continued their

collaboration. Doisy prepared ovarian extracts and mailed them to Allen for experiments. In 1923 and 1924, Allen and Doisy reported the isolation from pig ovaries and the administration to animals of “an ovarian hormone.”

In 1926, Sir Alan S. Parkes and C.W. Bellerby coined the basic word “estrin” to designate the hormone or hormones that induce estrus in animals, the time when female mammals are fertile and receptive to males. Doisy and his students Veler and Thayer in St. Louis isolated a few milligrams of estrogen in crystalline form in 1929 from large amounts of urine from pregnant women. The terminology was extended to include the principal estrogens in humans, estrone, estradiol, and estriol, in 1932 at the first meeting of the International Conference on the Standardization of Sex Hormones in London, although significant amounts of pure estradiol were not isolated until 1936. At this same meeting, the pioneering chemists were bemoaning the problem of scarcity that limited supplies to milligram amounts when a relatively unknown biochemist, A. Girard from France, offered 20 g of crystalline estrogen derived by the use of a new reagent to treat mare’s urine.<sup>481</sup>

In the 1920s, George W. Corner at the University of Rochester invited Willard Myron Allen, an organic chemist who was then a medical student, to join him in the study of the corpus luteum. Within 2 years, they had a pure extract, but it was not until 1934 that crystalline progesterone was isolated almost simultaneously in several countries. It took the corpora lutea of 50,000 pigs to yield a few milligrams. At the Second International Conference on the Standardization of Sex Hormones in London, Corner and Allen proposed the name progestin. Others proposed luteosterone, and, at a cocktail party, the various biochemists agreed to call the chemical progesterone.<sup>481</sup>

Hormones were being administered to patients in the 1940s, but supplies were very limited. And with a scarce supply, hormones were incredibly expensive. Progesterone, for example, cost \$200 per gram. “To secure barely enough androsterone to cover the head of a pin, Adolph Butenandt had had to start with nearly four thousand gallons of urine; to obtain less than one hundredth of an ounce of pure testosterone crystals, Ernst Laqueur had had to process nearly a ton of bulls’ testicles. It took a full ton of cholesterol, from the spinal cords or brains of cattle or from the grease of sheep’s wool, to yield just twenty pounds of the starting material from which progesterone ultimately could be obtained. Edward Doisy had had to process the ovaries of more than 80,000 sows to get just 12,000ths of a gram of estradiol.”<sup>482</sup>

In the 1930s, the Ayerst Company was extracting estrogens from the urine of pregnant women. Limited by the problems of supply, low activity, and bad taste and odor, Gordon A. Grant, head of biochemistry for Ayerst, suggested in 1939 that they use urine from horses. The process produced sodium salts from the sulfate esters of the various estrogens, yielding a water-soluble conjugate. Premarin (conjugated estrogens)

was approved in Canada in 1941 and in the United States in 1942 for the treatment of symptoms associated with menopause.<sup>483</sup> The tablets were and are still designated as variations of 1.25 mg, based on the equivalent amounts of Premarin and estrone (1.25 mg) that could produce the same effect in the Allen-Doisy bioassay (amount required to produce an increase in rat uterine weight). It was not until 1972 that the first quantitative analysis of Premarin was performed, based on gas chromatography. Modern studies indicate that there is a large number of steroids in Premarin, even androgens and progestins, but only the 10 estrogens are present in sufficient quantity to have clinical effects ([Table 17.7](#)).

## **TABLE 17.7 Postmenopausal Hormone Therapy**

## Composition of Conjugated Estrogens (Premarin)

Sodium estrone sulfate	49.3%
Sodium equilin sulfate	22.4%
Sodium 17 $\alpha$ -dihydroequilin sulfate	13.8%
Sodium 17 $\alpha$ -estradiol sulfate	4.5%
Sodium $\Delta$ 8,9-dehydroestrone sulfate	3.5%
Sodium equilenin sulfate	2.2%
Sodium 17 $\beta$ -dihydroequilin sulfate	1.7%
Sodium 17 $\alpha$ -dihydroequilenin sulfate	1.2%
Sodium 17 $\beta$ -estradiol sulfate	0.9%
Sodium 17 $\beta$ -dihydroequilenin sulfate	0.5%



# **ESTROGEN FORMULATIONS AND ROUTES OF ADMINISTRATION**

---

## Oral Administration

The relative potencies of commercially available estrogens are of great importance when prescribing estrogen, and the clinician should be familiar with the following potencies ([Table 17.8](#)).

### **TABLE 17.8 Relative Estrogen Potencies**

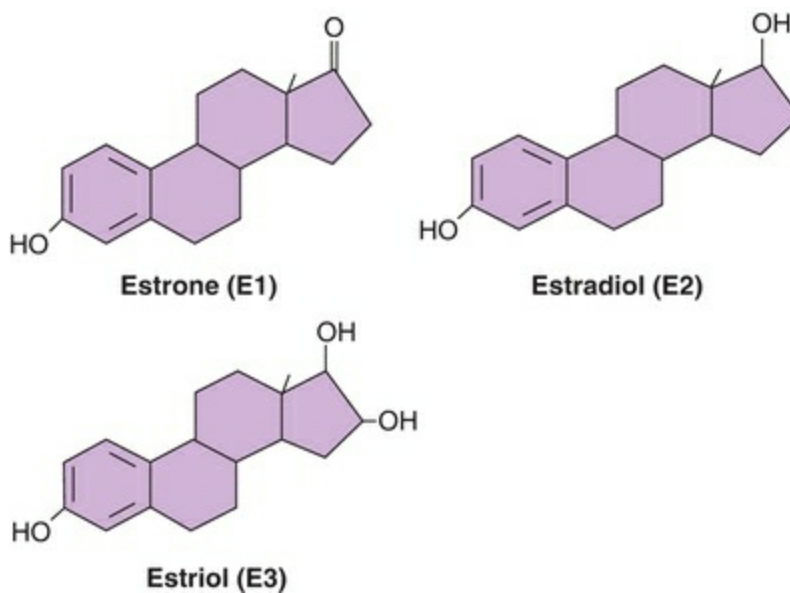
<b>Estrogen</b>	<b>FSH Levels</b>	<b>Liver Proteins</b>	<b>Bone</b>
Conjugated estrogens	1.0 mg	0.625 mg	0.625 mg
Micronized estradiol	1.0 mg	1.0 mg	1.0 mg
Estropipate (piperazine estrone sulfate)	1.0 mg	1.25 mg	1.25 mg
Ethinyl estradiol	5.0 µg	2–10 µg	5.0 µg
Estradiol valerate	—	—	1.0 mg
Esterified estrogens	—	—	0.625 mg
Transdermal estradiol	—	—	50 µg

Data from **Dennerstein L, Lehert P, Burger HG, Dudley E**, Mood and the menopause transition, *J Nerv Ment Dis* 187:685, 1999; **Smith-DiJulio K, Woods NF, Mitchell ES**, Well-being during the menopausal transition and early postmenopause: a within-stage analysis, *Womens Health Issues* 18:310, 2008; **Woods NF, Mitchell ES, Percival DB, Smith-DiJulio K**, Is the menopausal transition stressful? Observations of perceived stress from the Seattle Midlife Women's Health Study, *Menopause* 16:90, 2009; **Avis NE, McKinlay SM**, A longitudinal analysis of women's attitudes toward the menopause: results from the Massachusetts Women's Health Study, *Maturitas* 13:65, 1991; **Morse CA, Smith A, Dennerstein L, Green A, Hopper J, Burger H**, The treatment-seeking woman at menopause, *Maturitas* 18:161, 1994; **Defey D, Storch E, Cardozo S, Diaz O, Fernandez G**, The menopause: women's psychology and health care, *Soc Sci Med* 42:1447, 1996.<sup>9,10,11,12,13,14</sup>

The 17 $\alpha$ -ethinyl group of ethinyl estradiol (by resisting metabolism) enhances hepatic effects, because no matter by which route it is administered, liver function is affected.<sup>484</sup> The same is true for CEEs. Contrary to the case with estradiol, the liver appears to preferentially extract ethinyl estradiol and CEEs regardless of the route of administration. Thus, the route of administration appears to influence the metabolic responses only in the case of specific estrogens, most notably estradiol.

A major factor in the potency differences among the various estrogens (estradiol,

estrone, estriol; **Figure 17.11**) is the length of time that the estrogen binds to its receptor. The higher rate of dissociation with the weak estrogen (estriol) can be compensated for by continuous application to allow prolonged binding and activity. Estriol has only 20–30% affinity for the estrogen receptor compared with estradiol; therefore, it is rapidly cleared from a cell. However, if the effective concentration is kept equivalent to that of estradiol, it can produce a similar biologic response.<sup>485</sup> However, at least two studies have been unable to demonstrate prevention of bone loss with the administration of 2 mg estriol daily, suggesting that target organ response may vary.<sup>486,487</sup> In pregnancy, where the concentration of estriol is very great, it can be an important hormone not just a metabolite. Because estriol protects the rat against breast tumors induced by various chemical carcinogens,<sup>488</sup> it has been hypothesized that a higher estriol level protects against the more potent effects of estrone and estradiol. But, antagonism of estradiol occurs only within a very narrow range of the ratio of estradiol to estriol, a range that is rarely encountered either physiologically or pharmacologically.<sup>489</sup> Below this range, estradiol is unimpeded; above this range, estriol itself exerts estrogenic activity. Commercial preparations containing estriol, estradiol, and estrone comprise sufficient amounts of estrone and estradiol to produce standard clinical effects.<sup>490</sup>



**FIGURE 17.11**

Esterified estrogens are synthetically prepared from plant precursors and are composed mostly of sodium estrone sulfate with a 6–15% component of sodium equilin sulfate. Estradiol valerate is rapidly hydrolyzed to estradiol; therefore, the pharmacology and effects are comparable at similar dosages.<sup>491</sup>

# Transdermal Estrogen Administration

Transdermal estradiol can also be administered by a patch, gel, emulsion, or spray. The patches first used for transdermal administration of estrogen contained an alcohol reservoir; estrogen was released through a semipermeable membrane attached to the skin with an adhesive. In the current generation of estrogen patches, the hormone is dissolved and distributed throughout the adhesive matrix. In a study of women who had previously discontinued hormone patches because of skin irritation (contact dermatitis), skin reactions were less common with the newer matrix patches.<sup>492</sup> In addition, the matrix patches are better tolerated in tropical environments.<sup>493</sup> The patches are designated according to the amount of estradiol delivered per day with formulations delivering as little as 14 to as much as 100  $\mu\text{g}$  daily and are available in varying doses and various trade names (Climara and Vivelle are commonly available in the United States). The gel is similarly available under various trade names (Divigel, EstroGel, Estreva Gel) and in varying doses and can be applied once daily on an arm, anywhere from the wrist to the shoulder, or the thigh, without rubbing or massaging and alternating sides.<sup>494,495</sup> The emulsion, Estrasorb, is packaged in foil pouches; usually two packets are applied daily, one to each thigh, and rubbed in thoroughly. Evamist is the transdermal spray, and the usual dose is one spray daily to the forearm (if more than one dose is required daily, each spray is on a separate site).<sup>496</sup> Elestrin is available in a metered dispenser. Simultaneous use of sunscreen on the site of administration should be avoided. If dosage is being monitored by blood estradiol levels, blood should be drawn from a site where transdermal estradiol has not been applied for several days. **The ideal dose of estrogen is that which allows for systemic symptom relief.**

## Circulating Estradiol Levels in Users of Oral Versus Transdermal Estrogen

The concentration of estrogen in the hepatic portal system after oral administration is 4 to 5 times higher than that in the periphery.<sup>497</sup> Because of first-pass metabolism in the liver, oral estradiol results in a circulating estrone to estradiol ratio of approximately 5; with transdermal administration, the ratio is 1. The first-pass effect has important lipoprotein effects. For example, studies have demonstrated an increase in HDL and decrease in LDL and cholesterol with oral estrogens (discussed earlier in this chapter), an effect that is less prominent with transdermal estrogen administration.<sup>498,499</sup> However, English data indicate that the transdermal administration of 50  $\mu\text{g}$  estradiol twice a week is as effective as 0.625 mg oral conjugated estrogens, when combined with a progestin in sequential regimens, on bone mineral density (BMD) and lipids over a duration of 3 years.<sup>500</sup> Standard doses of estrogen administered transdermally (50  $\mu\text{g}$ )

protect against fractures as do standard doses of oral formulations.<sup>501</sup> While lower doses of estrogens can provide effective suppression of vasomotor symptoms as well as improve BMD, data on fracture risk reduction with low-dose regimens are lacking.<sup>502</sup>

Studies comparing circulating estradiol levels in women receiving oral or transdermal estrogen reveal that while estradiol levels are in therapeutic range for bone protection, there exists substantial variation among individuals.<sup>503</sup> Furthermore, due to the chemical components of CEEs (which are not measurable in serum samples on routine assays), it is difficult to measure a therapeutic level of estrogen in CEE users. In addition, individual women metabolize estrogen differently, depending on the route of administration, liver function, body composition, body size, potential medication interactions, skin absorption (for transdermal preparations), and the presence of binding proteins; all these can contribute to individual variations in serum estradiol levels.<sup>504</sup> The only way to accurately compare clinical effectiveness of oral and transdermal estrogen delivery is to determine if the two methods of administration yield comparable blood levels; however, the first-pass hepatic effect may account for differences in clinical effectiveness and this is difficult to quantify. The first-pass effect is particularly pronounced with oral estrogen formulations and raises SHBG levels such that total serum estradiol levels are greatly affected. A potential advantage of transdermal treatment because it has minimal to no effect on SHGB levels is the absence of a reduction in free, unbound testosterone levels (which may have implications for sexual function in a subset of users) as are observed with oral estrogen therapy.<sup>503</sup>

## **Systemic Effects of Hormone Therapy**

### **Clotting Factors**

First-pass hepatic metabolism affects the synthesis of clotting proteins, markers of coagulation and fibrinolysis that can influence the risk of thrombosis and CHD events. Oral estrogen increases factor VII and prothrombin 1 and 2 fragment, whereas transdermal estrogen decreases factor VII.<sup>505,506,507,508</sup> Oral estrogen also increases circulating levels of matrix metalloproteinases, MMP-2 and MMP-9, enzymes that are associated with a tendency for clotting.<sup>509</sup> However, what is important is to understand the different effects of oral and transdermal delivery on clotting factors and how they translate into clinical differences and cardiovascular risk.

### **Activated Protein C (APC) Resistance and Risk of Venous Thromboembolism (VTE)**

Resistance to APC is an important marker for venous thrombosis in individuals with

inherited thrombogenic mutations and even in the absence of these mutations. Oral estrogen increases APC resistance, whereas transdermal estrogen has no significant effect on this marker.<sup>510,511</sup> Based on this difference, one would predict that transdermal delivery of estrogen would be less likely than oral delivery of estrogen to be associated with VTE.

A French case-control study (epidemiologic studies of the link between the transdermal route of administration and a relatively rare event are possible in France because of the popularity of the transdermal method) reported no increased risk of VTE in users of transdermal estrogen, as compared with a fourfold increase in oral estrogen users.<sup>512,513,514</sup> Estrogen users who carried a factor V Leiden mutation or a prothrombin mutation had a 25-fold higher risk of VTE than did women who did not use estrogen and did not have either mutation. The women with a prothrombotic mutation who used transdermal estrogen had a VTE risk that was similar to that of women with a prothrombotic mutation who did not use estrogen. The French E3N prospective cohort study also reported an increased risk of VTE with current users of oral therapy, a hazard ratio of 1.7 (CI = 1.1–2.8), a ratio that is similar to the usual twofold increase repeatedly documented in the literature, and no increase with transdermal estrogen.<sup>515</sup> Analysis of the WHI trials noted that despite an increase in APC resistance, this did not explain the increase in ischemic stroke noted in oral HT users.<sup>516,517</sup> Venous thrombosis is discussed in more detail in the hormone therapy section of this chapter.

## **Lipids and Hepatic Enzymes**

Both oral and transdermal estrogens reduce total cholesterol, LDL cholesterol, and lipoprotein(a). Compared with transdermal estrogen, oral estrogen produces significantly greater elevations in HDL cholesterol and increases triglycerides, whereas transdermal estrogen decreases triglyceride levels.<sup>505,507,518,519,520</sup> Indeed, triglyceride levels markedly elevated in response to oral therapy return to normal when treatment is changed to transdermal administration.<sup>521</sup> In addition, oral estrogen therapy is associated with an increased risk of gallstones.<sup>522</sup> This risk is present in current and former estrogen users and is somewhat attenuated with the addition of progestin to estrogen therapy.<sup>522</sup>

## **Inflammatory Markers**

Women on oral estrogen have increased levels of CRP, whereas those taking transdermal estrogen do not.<sup>421,422,505,507,518,523,524</sup> In fact, oral hormone therapy while increasing CRP reduces the circulating levels of other inflammatory markers (E-selectin, intercellular adhesion molecule-1, vascular cell adhesion molecule-1, monocyte chemoattractant protein-1, and tumor necrosis factor- $\alpha$ ) with inconsistent

effects on IL-6.<sup>421,525</sup> Transdermal estrogen does not affect levels of these inflammatory markers. It is not certain that the decrease in CRP levels with statins and the increase with oral estrogen are instrumental in clinical outcomes or reflect other effects.

A longitudinal study of 346 postmenopausal women taking oral HT reported that elevated CRP was a strong predictor of future cardiac events, but only in those with increased IL-6 levels.<sup>523</sup> An increase in CRP alone was not associated with an excess of events. **The difference in CRP levels between users of oral versus transdermal therapy, especially in younger postmenopausal women, is of little clinical significance.** In fact, in the Estrogen Replacement on Progression of Coronary Atherosclerosis trial, estrogen-induced increases in CRP had no effect on disease progression, as measured by serial angiograms.<sup>524</sup> A study from the WHI confirmed the correlation between baseline levels of CRP and an elevated risk of CHD, **but the increase in CRP induced by oral hormone therapy did not further increase the risk.**<sup>423</sup> While CRP may cause endothelial inflammation and subsequent atherosclerosis, it may also very well be elevated secondary to first-pass hepatic metabolism (i.e., pharmacologic effect); unlike IL-6, its elevation has an overall proinflammatory effect.<sup>517</sup>

## Myocardial Infarction Risk

Both oral and transdermal administration of hormone therapy are associated with a decrease in myocardial infarction risk in observational studies.<sup>526</sup> However, the WHI trials and postintervention data offer additional insight and will be discussed in further detail later in this chapter.

## Metabolic Syndrome

The menopausal transition itself is associated with increased likelihood of metabolic dysfunction. However, in a review of several RCTs, it was noted that overall effects on markers of the metabolic syndrome, including insulin resistance, suggested a neutral or improved metabolic profile.<sup>527</sup> Despite this favorable effect, in women with the metabolic syndrome, caution is recommended given the increased risk of cardiovascular events, as noted in a nested case-control study of CHD in the WHI trials.<sup>527,528</sup> Transdermal estradiol has minimal effects on inflammation, coagulation, and insulin sensitivity.<sup>528,529</sup>

## Effects in Smokers

Limited evidence suggests that postmenopausal women who smoke may have a better response to transdermal estrogen than to oral estrogen, including greater reductions in



total peripheral resistance, vascular sympathetic tone, and norepinephrine levels, and increased vascular responsiveness.<sup>530</sup> Smokers receiving transdermal estradiol have decreased plasma viscosity and thromboxane B<sub>2</sub> levels.<sup>530</sup> These results raise the possibility, although the data are limited, that smokers may represent a group of women for whom transdermal estrogen would be an advantage.

## **Carbohydrate Metabolism**

There is little difference between the oral and transdermal methods of delivery on carbohydrate metabolism. Both methods have a beneficial impact on central abdominal fat content, glucose levels, and insulin resistance, associated with a reduced risk of developing adult-onset diabetes mellitus.<sup>531,532,533,534,535,536</sup> The effect of hormone therapy on carbohydrate metabolism/diabetes risk will be discussed in further detail in the hormone therapy section of this chapter.

## **Skeleton**

Effects of menopausal hormones on bone metabolism and BMD are discussed later in this chapter in the section on osteoporosis.

## Estradiol Implants

Estradiol pellets are available in doses of 25, 50, and 75 mg for subcutaneous administration twice yearly. The 25-mg pellet provides blood levels in the range of 40–60 pg/mL, levels that are comparable with those obtained with standard oral doses.<sup>537,538</sup> However, the effect of subcutaneous regimens is cumulative, and after several years, the blood levels are 2 to 3 times higher and can persist for up to 2 years following last insertion. We believe that estradiol pellets do not confer any advantage over the standard hormone regimens. We recommend that women receiving estradiol pellets be monitored with blood levels of estradiol. In women in whom serum estradiol levels are greater than 200 pg/mL (or even >100 pg/mL), prolonging intervals between insertions should be considered.

## Oral Versus Transdermal Administration

It is difficult to draw conclusions about clinical differences between oral and transdermal hormone delivery based on secondary markers. Epidemiologic studies on clinical events are needed. However, this is a challenge because of the relatively small number of women receiving transdermal estrogen. In addition, the studies must adjust for individual variability of dosing to ensure that circulating estrogen levels in the patients being studied are similar.

Given that transdermal route of delivery is suggested to lessen the risk for thrombotic events linked with exogenous estrogen use, it often is preferred by patients and, when applicable, allows monitoring of serum estradiol levels. Although comparison studies have not been performed, it is reasonable to expect similar pharmacokinetics for all transdermal methods—more stable/constant estradiol levels, less fluctuation, and theoretical benefits over oral therapy. Furthermore, because of lack of effects of transdermal delivery on serum SHBG levels and thereby with minimal effect on free androgen levels, transdermal method for estradiol delivery may be preferable in women with impaired sexual function.

## Key Points

- **Based on the evidence to date, transdermal estrogen therapy seems a preferred option for women who are deemed eligible for HT use after taking into account individual woman's personal and family histories and after ruling out absolute and relative contraindications to HT use.**
- **Sufficient evidence suggests that transdermal route of estrogen**

**administration be preferentially considered if decision for initiating HT is made after detailed counseling and weighing of risks versus benefits of HT for the following patients:**

- **Women deemed at risk for VTE**
- **Women with spontaneous or estrogen-induced hypertriglyceridemia**
- **Obese women with metabolic syndrome**
- **Diabetic and hypertensive women**
- **Smokers**
- **Transdermal route for estrogen therapy should be preferentially considered in women with complaints of hypoactive sexual desire or decreased libido.**

# Vaginal Administration of Estrogen

## Very-Low-Dose Method

Some patients do not gain full relief from the symptoms of vaginal atrophy with oral or transdermal administration of estrogen. Local vaginal administration makes sense for these patients. Vaginal treatment is especially helpful when a rapid response is desired. In addition, there are many women who desire the genitourinary effects of estrogen, but either must or wish to avoid systemic therapy. Overall, there is no evidence that one method or preparation is superior to the others in achieving clinical response. **Measurement of vaginal pH from the lateral vaginal wall is a simple and inexpensive way to assess adequate treatment of the vagina. It has been impressive in our experience and others how an acidic pH (<4.5) obtained from the lateral, outer third of the vagina correlates well with good estrogen effects. In a recent randomized controlled trial, it was also found to correlate with vaginal maturation index, symptomatic vulvovaginal atrophy, and visual inspection of vaginal epithelium.**<sup>241,242,539</sup>

Estrogen in the form of vaginal creams is absorbed very readily from a vagina with immature, atrophic mucosa.<sup>540</sup> Indeed, the initial absorption is rapid, and relatively high circulating levels of estrogen are easily reached. As the vaginal mucosa matures, absorption decreases.<sup>541</sup> This decline takes approximately 3–4 months, after which lesser but still significant absorption takes place.<sup>542</sup> Effective treatment of vaginal atrophy with minimal absorption can be achieved with the administration of 0.3 mg conjugated estrogens, 2 to 3 times per week.<sup>543,544</sup> Typically, addition of a progestogen is not indicated with low-dose therapy; however, data regarding endometrial safety for  $\geq 1$  year are not available. **We believe that treatment with a vaginal cream longer than 12 months requires endometrial surveillance.**

The amount of estradiol delivered in low-dose tablet form or a ring is not sufficient to treat menopausal symptoms, but effectively improves local urogenital atrophy and reduces recurrent urinary tract infections. This has been accepted as a method to relieve atrophic vaginal symptoms in women with contraindications to estrogen treatment; however, systemic effects do occur, although not deleterious effects.<sup>6</sup>

**Estring** is a 55-mm-diameter silicone ring that contains 2 mg estradiol, with a release rate of 7.5  $\mu\text{g}/\text{day}$  for 90 days.<sup>545</sup> European studies have demonstrated that vaginal maturation can be achieved with this ring that can be left in place for 3 months, with a low level of systemic absorption.<sup>546,547</sup> The subjective symptoms associated with vaginal atrophy are rapidly relieved. No change in endometrial thickness was observed

after 1 year of treatment.<sup>548</sup>

**Vagifem** is a vaginal formulation that is currently available in the United States as a tablet that contains 10 µg estradiol (was previously also available in a higher strength of 25 µg); the initial dose of one tablet daily provides relief from atrophic symptoms within 2 weeks.<sup>549</sup> After the first 2 weeks, the maintenance dose is twice weekly, and endometrial thickness has been reported to not change from baseline; however, the study was only 6 months in duration.<sup>550</sup> One 2-month study found no evidence of endometrial stimulation; another reported one case of vaginal bleeding with endometrial proliferation.<sup>551,552,553</sup>

The systemic absorption of estrogen from vaginally administered formulations (low-dose estradiol ring or tablet) is very low, especially after the vagina achieves estrogen-induced maturation (about 3 months). Is this low level of absorption free of the risk of endometrial hyperplasia? The problem is that all studies have been too short (all 1 year or less, except one 2-year study) to determine long-term endometrial safety. Although systemic absorption occurs, the circulating estradiol levels with these low-dose methods remain in the normal postmenopausal range.<sup>548,550,554,555,556,557</sup> But, because the small increase in circulating estradiol levels causes distant target tissue responses (e.g., an increase in bone density or an improvement in the lipid profile<sup>558,559</sup>), clinicians cannot assure patients that these methods are totally free of systemic activity.<sup>560</sup> **Although the change in blood levels is very slight and for that reason not effective for the relief of vasomotor symptoms, we believe long-term treatment requires ultrasonographic monitoring of endometrial thickness with biopsy when indicated. This ultrasonographic approach is more preferable than complicating the treatment regimen with the addition of a progestational agent. We further suggest that each patient titrate her dose and schedule of treatment to balance an effective response with minimal dosing. For women who are breast cancer survivors and are considering this treatment, decisions should involve patients' oncologist, given the potential risk of increased systemic estrogen levels.**<sup>561</sup> Of note, postmenopausal women taking an AI in particular require special consideration given their lower estradiol levels. In a recent nested case-control study assessing the risk of breast cancer recurrence in women on tamoxifen or AI receiving vaginal estrogen therapy, there was no increase in breast cancer recurrence; caution with interpretation for the AI group however as statistical power was lacking.<sup>562</sup>

## Standard Dose Method

A vaginal ring (Femring, estradiol acetate) that releases estradiol acetate provides 50 or 100 µg estradiol per day over a 3-month time span.<sup>563,564</sup> Estradiol acetate is a

prohormone, which is rapidly hydrolyzed to estradiol that is reflected in blood estradiol levels similar to those achieved with oral and transdermal methods. The systemic levels achieved effectively suppress hot flushing, and a beneficial impact on bone is to be expected. Endometrial protection requires the addition of a progestin in the presence of a uterus.

# Role of Monitoring Blood Levels of Estradiol in Estrogen Users

Monitoring the estradiol blood level in postmenopausal women does not have a role in routine management. However, in women not responding to standard HT dosing, it may be beneficial to assess serum estradiol levels. Monitoring however is not as straightforward as it would seem. There are two primary difficulties. First, the clinical assays available differ considerably in their technique and quality (laboratory and antibody variations). Second, the various commercial products represent a diverse collection of estrogenic compounds, ranging from estradiol to unique equine estrogens. Although the body interconverts various estrogens into estrone and estradiol, is this process relatively consistent within and between individuals? A highly specific assay for estradiol will detect very low levels of estradiol in women receiving 0.625 mg CEEs; nevertheless, most clinical assays will report a level of 40–100 pg/mL in these women.

We find measurement of blood estradiol levels very useful in selected patients, such as the patient who requests ever-increasing doses of estrogen for the treatment of symptoms, which in the presence of very high blood levels of estradiol can be confidently diagnosed as psychosomatic. What each clinician must do is learn what blood level of estradiol as performed by the local laboratory is associated with the standard doses of hormone therapy (0.625 mg conjugated estrogens, 1 mg estradiol, 50 µg transdermal estradiol) and consistently use the same laboratory. This range is 40–100 pg/mL estradiol when the estrogen is taken the evening before the office visit (with transdermal administration, blood sampling should be obtained the day before new patch placement); the range reflects individual variation including the variability from peak to nadir values. **Remember that because FSH is also regulated by a factor other than estrogen (i.e., inhibin), FSH levels cannot be used to monitor estrogen dosage.** Postmenopausal hormone therapy will produce only a 10–20% decrease in FSH and LH, and there is great individual variability in the responses.<sup>565</sup>

**Products containing ethinyl estradiol (commonly used in combined hormonal contraceptives) will not affect the measurement of circulating estradiol levels.** Ethinyl estradiol circulates without being changed, and the antibodies in the immunoassays for estradiol will not recognize it. It is for this reason that women on oral contraceptives have very low measurements of estradiol. This problem for the postmenopausal use of ethinyl estradiol is not a major handicap because ethinyl estradiol is slowly metabolized, and blood levels are relatively stable with less variation from individual to individual compared with the other estrogen formulations.

# Menopausal Hormone Therapy: Sequential and Continuous Regimens

Postmenopausal hormone therapy initially consisted only of sequential regimens that were logical reflections of the cyclic estrogen and progesterone patterns in a premenopausal menstrual cycle. Clinical trials established the doses and durations for progestin administration that would effectively protect the endometrium against unchecked estrogen-driven proliferation.<sup>566</sup> Progestin withdrawal bleeding occurs in 80–90% of women on a sequential regimen.<sup>567,568,569</sup> The continuous combined method of treatment evolved to improve patient continuance that was adversely affected by bleeding and other symptoms triggered by the cyclic hormonal changes. The addition of a daily dose of a progestin to the daily administration of estrogen allowed the progestin dose to be smaller, provided effective protection against endometrial hyperplasia, and resulted in amenorrhea within 1 year of treatment in 80–90% of patients.<sup>568,570,571,572</sup>

In the sequential regimen, estrogen is administered daily and progestins for 2 weeks of every month, using the comparable doses of the following progestogens noted below and listed in [Table 17.9](#)<sup>569,570,573,574</sup>:

## TABLE 17.9 Progestins Available Worldwide



**Estimated  
Comparable  
Oral Doses**

Progesterone	Oral peanut oil tablet	200 mg
21-Carbon derivatives	Medroxyprogesterone acetate	5.0 mg
	Megestrol acetate	5.0 mg
	Cyproterone acetate	1.0 mg
	Dydrogesterone	10.0 mg
	Chlormadinone acetate	5–10.0 mg
	Medrogestone	10.0 mg
19-Norpregnanes	Trimegestone	0.0625–0.50 mg
	Promegestone	0.5 mg
	Nomegestrol	5.0 mg
	Nomegestrol acetate	3.75–5.0 mg
	Demegestone	
	Nestorone (nonoral)	0.05–0.1 mg
19-Nortestosterone family		
Ethinylated	Norethindrone	0.7–1.0 mg
	Norethindrone acetate	1.0 mg
	Levonorgestrel	0.075 mg
	Desogestrel	0.15 mg
	Norgestimate	0.09 mg
	Gestodene	0.20 mg
	Norethynodrel	
	Lynestrenol	
	Ethinodiol diacetate	
Nonethinylated	Dienogest	2.0 mg
Derived from spironolactone and nonethinylated	Drospirenone	2.0 mg

- 5 mg medroxyprogesterone acetate
- 1.0 mg norethindrone acetate
- 200 mg micronized progesterone

In the daily continuous, combined regimen, progestins are combined with estrogen in the following comparable doses<sup>571,572,575</sup>:

- 1.5 or 2.5 mg medroxyprogesterone acetate
- 0.35 mg norethindrone
- 0.5 or 1.0 mg norethindrone acetate
- 100 mg micronized progesterone
- 2 mg drospirenone
- 2 mg dienogest

# Menopausal Hormone Therapy: Estrogen Dose

There has been a progressive decrease in estrogen doses in postmenopausal hormone therapy regimens. For many years, the standard dose of estrogen was 0.625 mg conjugated estrogens, 1–2 mg micronized estradiol, 1–2 mg estradiol valerate, or equivalent doses of other estrogens such as 5 µg ethinyl estradiol. Lower doses have been proven on the average to be as effective as these “standard” doses, providing clinicians and patients with more options. Conjugated estrogens in a dose of 0.3 or 0.45 mg effectively produce a gain in bone density when combined with 1.5 mg medroxyprogesterone acetate, and a dose of 0.5 mg micronized estradiol produces comparable effects.<sup>576,577,578,579</sup> The 0.45/1.5 mg and 0.3/1.5 mg conjugated estrogens/medroxyprogesterone acetate combinations improve vaginal atrophy, reduce hot flushing, and improve measures of sexual function in a pattern that is quantitatively and qualitatively similar to the 0.625/2.5 mg combination with less mastalgia.<sup>580,581</sup> These lower-dose combinations are associated with less breakthrough bleeding and a higher rate of cumulative amenorrhea compared with older standard doses and retain the favorable changes in the lipid profile.<sup>582,583</sup> At these lower doses of conjugated estrogens, the combination with progestin produces an additive effect; therefore, when these lower doses of estrogen are used without progestin, the effect on hot flushing will not be as great. In a dose-response study, the most efficacious dose of oral micronized estradiol was 1 mg/day.<sup>584</sup> The lower-dose combination of ethinyl estradiol and norethindrone acetate (2.5 µg/0.5 mg) is nearly as effective in treating hot flushes as the higher-dose combination (5.0 µg/1.0 mg).<sup>585</sup> **Vigilance is advised in assessing response with lower doses as there will be more women who respond poorly, probably because of a greater rate of metabolism and clearance.**

# Menopausal Hormone Therapy: Progestational Component

Many women do not tolerate treatment with progestational hormones. Typical side effects include breast tenderness, bloating, and depression. These reactions are significant detrimental factors with continuance. Breast discomfort associated with postmenopausal hormone therapy can be attributed largely to progestins. Comparison studies have not been performed to address whether this symptom is minimized by particular progestins. Can the progestational agent be administered less frequently? We are secure in our position, supported by clinical data, that a daily combination program effectively prevents endometrial hyperplasia. A sequential regimen that incorporates progestin exposure for less than 14 days has over time an increased risk of endometrial hyperplasia.<sup>586,587</sup> Sequential regimens with less than 14 days of progestin monthly or even long-term use of recommended schedules do not match the protection offered by the daily, continuous method of estrogen-progestin treatment.

Two metabolites of progesterone, allopregnanolone and pregnanolone, are believed to be responsible for progesterone's unique sedative effect. Treatment regimens with micronized progesterone should be taken at bedtime, and these estrogen-progesterone combinations are a good choice for women with sleep difficulties. A study in a sleep laboratory has demonstrated a significant improvement in sleep quantity and quality in women using a sequential regimen of estrogen and micronized progesterone in contrast to no effect in the group using medroxyprogesterone acetate.<sup>588</sup>

Some patients are very sensitive to medroxyprogesterone acetate. One can consider a trial of norethindrone instead. In a sequential regimen, the dose of norethindrone is 0.7 mg (available in the progestin-only, minipill oral contraceptive; each pill contains 0.35 mg norethindrone). In the continuous, combined regimen, the dose of norethindrone is 0.35 mg daily. Commercial combination products are available containing estradiol and norethindrone acetate.

Progesterone can also be administered vaginally. A vaginal gel allows the delivery of very low doses that can effectively protect the endometrium with low systemic levels because of a first-pass effect on the uterus.<sup>589</sup> The administration of 90 mg every 2 days produces secretory changes in the endometrium.<sup>590</sup> An application of the 4% commercial preparation (Crinone) twice weekly protects the endometrium and is associated with amenorrhea in most patients. In a sequential regimen, the 4% preparation should be applied daily for at least 14 days each month; however, long-term data on endometrial safety are lacking.<sup>591</sup> The application of a 100-mg vaginal tablet (Endometrin) every other day is also effective, with long-term follow-up of 3 years

demonstrating no endometrial hyperplasia.<sup>592</sup>

The transdermal estrogen-progestin combinations incorporate norethindrone acetate in a daily dose of 0.140 or 0.250 mg; or levonorgestrel in daily doses of 0.007, 0.015, 0.030, and 0.040 mg/day; and, in a sequential regimen, norethindrone acetate, 0.250 mg, or levonorgestrel, 0.010 mg.<sup>593,594,595</sup>

## **Infrequent Progestational Exposure: Long Sequential Regimens**

Such regimens are increasingly being considered, either for the convenience of lesser frequency of withdrawal bleeding episodes associated with cyclic progesterone use or for those wishing to minimize progestin exposure duration. Experience with extended-cycle regimens, however, is very limited. The administration of medroxyprogesterone acetate every 3 months was associated in one study with longer, heavier menses and unscheduled bleeding and a 1.5% incidence of hyperplasia at 1 year, whereas in another study, overall bleeding was less, but the incidence of hyperplasia was approximately 4%.<sup>596,597</sup> In a Dutch study that was only 12 weeks in length, simple endometrial hyperplasia was encountered at the end of the unopposed estrogen phase.<sup>133,598</sup> In yet another study, there was no endometrial hyperplasia encountered by 143 women who completed 2 years of treatment; however, the progestin administered every 3 months was of high dosage, 20 mg medroxyprogesterone acetate daily for 14 days.<sup>599</sup> In Finland, the addition of progestin at 3-month intervals was associated with a striking increase in the risk of endometrial cancer when this regimen was used for many years.<sup>600</sup> Most impressively, the Scandinavian Long Cycle Study, a clinical trial scheduled to last 5 years, was canceled after 3 years because of a 12.5% incidence of endometrial pathology and 1 case of endometrial cancer.<sup>575,601</sup> Given the lack of long-term data on safety of extended regimens, if a patient chooses such an approach, endometrial monitoring is advised. **Any program that differs from the standard regimen should consider periodic surveillance of the endometrium (as discussed earlier in this chapter). Even the long-term use of standard sequential regimens is subject to a small increase in the risk for endometrial cancer, and endometrial surveillance should be considered in women using this method.**

**We caution against long regimens in women who may be at an innately higher risk for endometrial hyperplasia and cancer, such as those with a personal history of endometrial hyperplasia, those who are obese, those who are insulin-resistant, and diabetic women.**

## **The Progestin Intrauterine Device**

The levonorgestrel-releasing IUDs (such as the Mirena or Skyla) are increasingly being used in estrogen-taking postmenopausal women to confer endometrial protection.<sup>602,603,604,605,606</sup> The intrauterine presence of the progestin effectively protects the endometrium against hyperplasia and cancer.<sup>209</sup> The local site of action provides endometrial protection while minimizing systemic progestin side effects; for example, estrogen's favorable lipid effects are not attenuated with intrauterine progestin.<sup>607</sup> As with the oral continuous, combined regimens, irregular breakthrough bleeding may occur in the first 6 months, and after 1 year, approximately 60–70% of the women are amenorrheic. The levonorgestrel system has the advantage of a 5- to 7-year duration of use. These methods provide treatment options that minimize substantially the systemic effects of progestins.

## Special Considerations for Progestin Use

Inclusion of progestational agent in menopausal hormone therapy regimen is exclusively for endometrial benefit. Thus, use of estrogen-alone hormone formulations reflects the standard of clinical care in managing menopausal symptoms in women without a uterus. However, there are some special conditions that warrant consideration of a combined estrogen-progestin regimen even in hysterectomized women.

### Key Points

- In women in whom hysterectomy and bilateral salpingo-oophorectomy is undertaken for management of endometriosis, we recommend a combination of estrogen plus progestogen. In general, following hysterectomy estrogen-only HT is required, if needed. However, given the role of estrogen in endometriosis growth/progression, this is one situation where combined HT is indicated following hysterectomy. Cases of adenocarcinoma have been reported in patients with pelvic endometriosis treated with unopposed estrogen.<sup>151,152,153,154,155,156</sup>
- Patients who have undergone procedures that have the potential to leave residual endometrium (e.g., a supracervical hysterectomy) should be treated with an estrogen-progestin combination. Responsive endometrium may be sequestered in patients who have undergone endometrial ablation,<sup>423,526</sup> and combined estrogen-progestin treatment is also recommended for these women.
- In women undergoing hysterectomy for management of early stage endometrial adenocarcinoma, if HT is being considered for symptom control, a combination regimen is advised given the potential protective action of the progestational agent.
- The combined estrogen-progestin approach makes sense for patients previously

treated for endometrioid tumors of the ovary.<sup>608</sup>

# ROLE OF ANDROGENS IN MENOPAUSE MANAGEMENT

---

The total amount of testosterone produced after menopause is decreased because the amount of the primary source, peripheral conversion of androstenedione, is reduced. The early postmenopausal circulating level of androstenedione decreases approximately 62% from young adult life.<sup>157</sup> Nevertheless, the menopausal decline in the circulating levels of testosterone is not great, from no change in many women to as much as 15% in others.<sup>59,153,157,163</sup> Testosterone therapy has been shown to improve sexual interest and overall psychological well-being in menopausal women. In an excellent longitudinal Australian study from 5 years before menopause to 7 years after menopause, the circulating levels of testosterone did not change.<sup>158</sup> Indeed, because of a decrease in SHBG, this Australian study calculated an increase in free androgens. The total amount of testosterone produced per day, however, is slightly decreased because the primary source, the peripheral conversion of androstenedione, is reduced. Because of this decrease, some argue that androgen treatment is indicated in the postmenopausal period.

The potential benefits of androgen treatment include improvement in psychological well-being and an increase in sexually motivated behavior. **Hypoactive sexual desire disorder is defined as a decrease in sexual activity sufficient to cause distress.** Beneficial effects of androgen treatment have been reported with the administration of relatively large doses of androgen.<sup>609</sup> In a well-designed, placebo-controlled study, lower doses of androgen (but still very pharmacologic, 5 mg methyltestosterone) contributed little to actual sexual behavior, although an increase in sexual fantasies and masturbation could be documented.<sup>610</sup> The transdermal testosterone treatment of women improved sexual function compared with a placebo group only in the dose that raised circulating testosterone levels to about 100 ng/dL (the upper limit of normal for reproductive-age women is 80 ng/dL in most laboratories).<sup>611</sup>

Any benefit must be balanced by the unwanted effects, in particular, virilization (acne, alopecia, and hirsutism) and a negative impact on the cholesterol-lipoprotein profile. In a short-term study comparing a product with estrogen and a relatively low oral dose of testosterone (1.25 mg methyltestosterone) to estrogen alone, a negative impact on the lipid profile was apparent within 3 months.<sup>612</sup> Over a 2-year period, the administration of estrogen (1.25 mg) combined with 2.5 mg methyltestosterone produced a significant overall adverse impact on the cholesterol-lipoprotein profile.<sup>613</sup> In addition, 30% of the patients experienced acne, and 36% developed facial hirsutism. A lower dose of this combination (0.625 mg esterified estrogens and 1.25 mg methyltestosterone) also significantly lowered HDL cholesterol.<sup>614</sup> The adverse impact



on the lipid profile is less (and may even be avoided) by the parenteral administration of testosterone.<sup>615</sup> Of course, the clinical effects of these metabolic changes are not known.

**It should be remembered that androgens do not protect the endometrium, and the addition of a progestin is still necessary.** It is uncertain (and unstudied) how much aromatization, especially local aromatization in target tissues, of the administered testosterone increases the estrogen impact and whether this might increase the risk of endometrial and/or breast cancer. The addition of androgen does not reduce the amount of breakthrough bleeding women experience with a continuous combination regimen.<sup>616</sup> Adding testosterone to an estrogen therapy program has been reported to provide no additional beneficial impact on the bone or on relief from hot flashes.<sup>613,617</sup> On the other hand, others have demonstrated a greater increase in bone density with an estrogen-androgen combination compared with estrogen alone, although the blood levels achieved were higher than those associated with standard postmenopausal hormone therapy.<sup>615</sup> In another study, only a very pharmacologic dose of methyltestosterone added to the bone density achieved with estrogen alone.<sup>618</sup> A greater effect on bone associated with androgen treatment may be indirect, reflecting higher free estrogen levels because of a reduction in SHBG and/or androgen-induced changes in muscle mass.

There is no doubt that pharmacologic amounts of androgen can increase libido, but these same doses result in supraphysiologic levels and produce unwanted effects.<sup>619</sup> In addition, patients on high doses of androgens often are somewhat addicted to this therapy. Small amounts of androgen supplementation can be provided in situations in which the patient and clinician are convinced that a depressed libido cannot be explained by psychosocial circumstances. In these cases, the lipid profile should be carefully monitored. Any positive clinical response may well be a placebo effect. The products that are available in various parts of the world include testosterone undecanoate (used orally), sublingual micronized testosterone, intramuscular injections, subcutaneous implants, and transdermal preparations (Intrinsa, applied twice a week).<sup>620</sup> For example, the testosterone transdermal gel marketed for use in men (AndroGel), 5 g/day, can be used at a starting dose of about 1 g/day. Testosterone undecanoate produces very high testosterone levels with great variability and is not recommended.<sup>621</sup> **If testosterone use is considered, our preferred method is to use a product that will allow dose to be titered by measuring the total testosterone blood level with the goal of maintaining concentration in the range of 20–80 ng/dL.**

The initial clinical trials concluding that the 300 µg transdermal dose of testosterone was effective for low libido consisted of women with either surgical (1,172 women) or natural menopause (549 women) who were being also treated with

estrogen.<sup>622,623</sup> A 1-year, randomized, placebo-controlled clinical trial of 814 women with hypoactive sexual desire disorder and not on estrogen therapy from 65 centers in the United States, Canada, Australia, the United Kingdom, and Sweden assessed the impact of transdermal testosterone that delivered 150 or 300 µg/day.<sup>624</sup> The higher dose of testosterone increased sexuality (including desire, arousal, orgasm, and pleasure) by 1.4 episodes per month compared with placebo. This increase appeared as early as the second month of treatment. The lower dose did not differ from placebo. In the higher-dose group, 30% reported unwanted androgenic effects (essentially an increase in facial hair). In addition, one woman in the low-dose group and three women in the high-dose group developed clitoral enlargement (the enlargement resolved in the woman receiving the low dose, but not in the high-dose women). The frequency of acne, alopecia, and voice deepening was the same in all groups. It is certainly plausible that with longer exposure to the high dose, more and more women would develop androgenic side effects. There were four cases of breast cancer in the treatment groups and none in the placebo group; however, one was diagnosed after only 4 months of treatment and one had a bloody nipple discharge before the trial started, making it difficult to determine if these were preexisting or de novo cancers.

In the Nurses' Health Study, the risk of invasive breast cancer associated with the use of combined estrogen and testosterone was nearly twofold increased.<sup>625</sup> This report from the Nurses' Health Study is complicated by the same problem in other breast cancer reports from this cohort: the hormone users (in this case, estrogen and testosterone) differ substantially from never-users. This requires multiple statistical adjustments, a process that is further influenced by the number of cases involved. The analysis is limited by relatively small numbers; there were only 29 cases of breast cancer among the estrogen-testosterone users. Nevertheless, the results should raise caution regarding the postmenopausal use of androgens.

If testosterone affects breast tissue, does it do so directly or is it aromatized locally into estrogen? The majority of studies indicate that testosterone inhibits proliferation of breast cancer cell lines in vitro, as well as in vivo markers of breast epithelial proliferation in animals and women,<sup>626,627</sup> suggesting that aromatization is of greater concern. Testosterone preparations such as implants and transdermal applications do carry the risk of target tissue aromatization, perhaps raising local estrogen levels to high levels in breast tissue. Perhaps, an argument against this possibility was the failure to demonstrate any increase in breast density associated with transdermal testosterone treatment, even with the higher dose.<sup>628</sup> However, the mean age of the women in this study was 54.6, and an increase in breast density with estrogen-progestin therapy is largely observed in women over age 55; in younger women, it is difficult to find any differences between hormone users and nonusers.<sup>629</sup>

In the transdermal testosterone trial with women not on estrogen treatment, there was a 10.6% incidence of vaginal bleeding in the women who had not undergone hysterectomy and were receiving the higher dose, compared with 2.6% in the placebo group and 2.7% in the low-dose group.<sup>624</sup> Was this due to aromatization of testosterone in the endometrium? There were no cases of endometrial hyperplasia or cancer in this trial, but again, a longer duration of exposure might have unwanted consequences. This issue cannot be resolved without long-term data. In addition, the long-term effects on the cardiovascular system are unknown.

Response in the clinical trials with transdermal testosterone did not correlate with testosterone levels at baseline, and higher levels during treatment did not predict androgenic side effects. This is not surprising because measurement of free and bioavailable testosterone is subject to considerable inaccuracy and variability. For this reason, testosterone levels cannot be used to diagnose the hypoactive sexual desire disorder.<sup>630</sup> The transdermal clinical trials have reported that all testosterone levels remained within the premenopausal ranges. However, the mean level of free testosterone was relatively high at 6.8 pg/mL, although within the reference range. According to the data in the supplemental appendix, available only online, the mean levels were at or above the upper end of the reference age. In addition, because of individual variability, there was a wide range of testosterone levels, with a significant number of values elevated above normal. For many women, these are not physiologic levels. We do not know if it is possible to avoid unwanted consequences by careful monitoring of blood levels.

The only testosterone formulation approved for exclusive use in female population in the United States is of a combination of esterified estrogen with methyltestosterone—a higher (2.5 mg methyltestosterone) and lower (1.5 mg methyltestosterone) dose combination formulation is available.<sup>631</sup> Compounded testosterone formulations in the form of gels, pellets, and injectable testosterone (decanoate, enanthate, cypionate) have been varyingly utilized, but are not FDA approved. With gels, 5 mg (1%) is recommended.<sup>632</sup> Varying doses have been used for injectable testosterone with currently no adverse effects noted; however, outcomes have only been measured over a 6-month period.<sup>633</sup> Exercising extreme caution when considering testosterone pellet therapy is warranted given concern for supraphysiologic doses achieved. Furthermore, in women with breast cancer, uterine cancer, cardiovascular disease, or liver disease, testosterone use is generally contraindicated.<sup>631</sup>

There is little doubt that the pharmacologic amounts of testosterone can produce favorable effects on sexuality, but it remains doubtful that maintaining testosterone levels within the normal physiologic range can have a beneficial impact on well-being and health. Some women receiving pharmacologic amounts of testosterone develop very

high circulating levels. The fundamental problem is that the long-term consequences of pharmacologic amounts of testosterone are unknown. **If a clinician and a patient choose to use supplemental androgens, our advice is to select a treatment that can be monitored with measurements of total testosterone in serum.** The choices include the testosterone transdermal patch, a testosterone skin gel (on the market for use in men), and testosterone compounded for individual use by a pharmacist. We are left with this question: is a modest increase of one or two episodes per month sufficient to offset the unanswered question of long-term safety? Some women would say yes, but the clinician has an obligation to avoid excessive doses and to educate the patient regarding the unanswered questions. **Prior to initiation, we recommend obtaining baseline lipid, and liver function tests and periodic surveillance (3 months following initiation and yearly thereafter) are recommended to ensure safety.** The free testosterone index can be used to monitor testosterone levels (goal of physiologic levels) with all testosterone formulations. Of note, oral methyltestosterone cannot be measured, as it is not detected in existing testosterone assays.<sup>631</sup> As long-term safety data are limited, it is highly recommended that a discussion for treatment discontinuation be made with patients at 6 months following initiation.<sup>631</sup>

**While a role of testosterone therapy in women's health remains somewhat controversial, in the setting of reduced libido, particularly in surgically menopausal women, testosterone may be beneficial for some menopausal women not responding to traditional HT.**

# Dehydroepiandrosterone

Adrenal androgen production decreases dramatically with aging. The mechanism is not known, but it is not due to the loss of estrogen at menopause nor can it be reversed with estrogen treatment.<sup>634</sup> The impressive decline (75–85%) in circulating levels of DHEA that occur with aging (greater in men than in women) has stimulated a search for a beneficial impact of DHEA supplementation.<sup>635</sup>

The only proven function of DHEA and its sulfate, DHEA-S, is to provide a pool of prohormone for conversion to androgens and ultimately estrogens. By age 70 or 80, the circulating levels in men and women are about 10% of peak levels that occur between 20 and 30 years of age. Systemic DHEA supplementation does not produce improvements in menopausal symptoms, mood, libido, cognition, or memory, but it does increase testosterone and decrease HDL cholesterol.<sup>636</sup> The acute administration of DHEA did produce a modest effect on sexual response in postmenopausal women, but the dose was enormous, 300 mg.<sup>637</sup>

Although low levels of DHEA and DHEA-S have been reported to be associated with increased risk of cardiovascular disease in men, in women conflicting results are found in cross-sectional data. In a longitudinal study of 236 women, higher levels of DHEA and DHEA-S in middle-aged women correlated with an increased risk of cardiovascular disease.<sup>638</sup>

DHEA supplementation, 50 mg/day, produced reproductive levels of DHEA-S in elderly men, did not change levels of testosterone and dihydrotestosterone, and raised estradiol and estrone levels, although still within normal range.<sup>639</sup> In women, 25 or 50 mg/day increased testosterone levels, decreased SHBG levels, and produced adverse effects on the lipid profile.<sup>640,641</sup> Exogenously administered DHEA is converted to potent androgens and estrogens. Potential long-term effects include hirsutism, alopecia, voice changes, prostate and breast effects, and an increased risk of CHD. Supplementation with DHEA requires titrating of dosage using the circulating level of total testosterone and keeping the concentration below 80 ng/dL. This is difficult because the U.S. Food and Drug Administration measured the DHEA content of 45 commercial products, and assayed values varied from 0% to 109.5%!<sup>642</sup>

In contrast to systemic DHEA formulations, a prospective, randomized, placebo-controlled trial of daily intravaginal use of DHEA (trade name Prasterone) in a dose of 0.5% (6.5 mg) demonstrated significantly improved symptoms of vaginal atrophy, with little change in the serum levels of DHEA, estradiol, and testosterone.<sup>643,644,645,646,647</sup> Presumably, the vaginally administered DHEA is converted locally to estrogen and testosterone within the vaginal tissue. In clinical trials comparing DHEA to 0.3 mg CEE

or 10 µg E2 daily, DHEA was found to be at least as effective as CEE and/or estradiol in improving vulvovaginal symptoms.<sup>648</sup> There was no effect of vaginal DHEA on the following tissues: the endometrium and liver; the effects on the bone are not yet known.

# SELECTIVE ESTROGEN RECEPTOR MODULATORS

---

A greater understanding of the estrogen receptor mechanism ([Chapter 1](#)) allows us to understand how mixed estrogen agonists/antagonists can have selective actions on specific target tissues. New agents are continuously being developed in efforts to isolate desired actions (vasomotor symptom benefit and bone effect) from unwanted side effects (endometrial and breast tissue effects). Indeed, in time, we can expect to see new products with progressively better agonist/antagonist profiles, yielding increasingly user-friendly drugs.

# Raloxifene

Raloxifene exerts no proliferative effect on the endometrium but produces favorable responses in bone and lipids.<sup>649,650,651,652</sup> The MORE (Multiple Outcomes of Raloxifene Evaluation) study of raloxifene administration to osteoporotic women reported results from 8 years of follow-up.<sup>653,654</sup> Women with low T-scores had approximately a 50% reduction in vertebral fractures with raloxifene treatment and with previous vertebral fractures, approximately 35%. However, **there has been no evidence of a reduction in hip or wrist fractures.** The major side effect was about a threefold increase in VTE. Raloxifene (and tamoxifen) shares with estrogen an increased risk for VTE.<sup>655</sup> The size of the risk is comparable for all three drugs, and nearly all the cases occur in the first 1 or 2 years of exposure. A small number of women experience hot flushing with raloxifene. Raloxifene treatment in the MORE trial had neither a positive nor a negative effect on cognition.<sup>656</sup>

Women who received raloxifene in the MORE trial had about an 80% reduction in the incidence of estrogen receptor–positive breast cancers. The CORE study, the Continuing Outcomes Relevant to Evista trial, was designed to measure the impact of four additional years of raloxifene (60 mg/day), beginning during the fourth year of the MORE trial.<sup>657</sup> Of the 7,705 participants initially randomized in the MORE trial, 3,510 women elected to continue raloxifene treatment (2,336 completed the CORE trial) and 1,703 continued on placebo (1,106 completed the trial). During the 4-year CORE study, raloxifene treatment was associated with a 66% (HR = 0.34; CI = 0.18–0.66) reduction of estrogen receptor–positive invasive breast cancer in the treated group. There was no difference in estrogen receptor–negative tumors. Over the entire 8-year period, the reduction in estrogen receptor–positive cancers reached 76%. In the 8-year period, there was no difference in the number of deaths in the two groups.

The Study of Tamoxifen and Raloxifene (STAR) trial enrolled 19,747 women at increased risk of breast cancer who were randomized to treatment with either raloxifene, 60 mg daily, or tamoxifen, 20 mg daily, in more than 500 centers in the United States, Canada, and Puerto Rico.<sup>658</sup> After an average treatment period of almost 4 years, the numbers of invasive breast cancers were identical in the two groups of women. It was estimated that these results were equivalent to about a 50% reduction (based on the previous results in the tamoxifen prevention trial),<sup>659,660</sup> but without a placebo arm, an accurate assessment was impossible. Thus, raloxifene appears to achieve the same reduction as tamoxifen in invasive breast cancers with a lesser increase in venous thrombosis and perhaps no increase in cataracts and uterine cancer. Fractures, as well as strokes and heart attacks, were equally prevalent in the two groups. “Quality of life” was said to be the same for both drugs.



Tamoxifen has been demonstrated to reduce the incidence of both lobular carcinoma in situ and ductal carcinoma in situ.<sup>659,660</sup> In the 7-year follow-up report of the tamoxifen for prevention study, the risk for breast cancer was 0.57 (CI = 0.46–0.79), a 43% reduction, not the 50% cited in the results above, and the risk for in situ disease was 0.63 (CI = 0.45–0.89), a 37% reduction.<sup>659</sup> Not only did raloxifene not yield a reduction in in situ cancers, the number with raloxifene in the STAR trial was greater. If raloxifene is truly preventing breast cancer, this should produce a reduction in in situ disease. Perhaps, with longer follow-up, a difference between the two treatment groups will no longer be apparent.

In a 2-year randomized trial in monkeys, raloxifene exerted no protection against coronary artery atherosclerosis despite changes in circulating lipids similar to those achieved in women.<sup>661</sup> The Raloxifene Use for The Heart (RUTH) study included more than 10,000 women from 26 countries, either at high risk for myocardial infarction or with known CHD.<sup>662,663</sup> The participants were randomized to placebo or raloxifene, 60 mg daily, and followed for up to 7 years. There was no effect of raloxifene treatment on CHD events; however, there was a small increase in stroke mortality. The results of the RUTH trial are not surprising. The known favorable impact of raloxifene on the cholesterol-lipid profile was not robust enough to prevent coronary events.

Because the Nurses' Health Study reported a reduction in coronary events associated with estrogen therapy administered to young postmenopausal women, the RUTH trial performed a post hoc analysis of the impact of raloxifene according to age of the women at entry to the study as well as subgroups such as the use of medications, including statins.<sup>663</sup> Overall, raloxifene did not increase or decrease coronary events in either of the treated groups. The only category demonstrating a significant difference, a 40% reduction in coronary events, consisted of women less than 60 years of age. Despite the statistically significant reduction in coronary events in women under age 60, there was no relationship in any subgroup according to years since menopause, even in the group less than 10 years postmenopausal. The women who were less than 60 years of age were an average of 9.9 years since menopause, compared with 19.4 years for the overall study population. A decision to use raloxifene should not be influenced by its effects on the cardiovascular system. This is a bone and breast decision.

**In our view, raloxifene is an option for prevention of osteoporosis-related spinal fractures, especially for patients reluctant to use hormone therapy or in those wanting to combine some bone protection with a reduction in the risk of breast cancer. We recommend, however, periodic evaluation of bone density at the hip, and if bone loss occurs, patient and clinician should consider another treatment option.**

# Ospemifene

Ospemifene (Ophena), the newest of these agents, has been approved by the FDA in the United States and Europe for its beneficial effects on vaginal tissue. It is being primarily given in a dose of 60 mg/day given orally for the treatment of vulvar and vaginal atrophy, sites where ospemifene exerts a significant estrogenic impact.<sup>664</sup> Ospemifene suppressed the development of breast cancer in the drug-induced mouse model, and post hoc analysis of safety data is reassuring in terms of effects on the breast, endometrium, and bone; vasomotor symptoms can worsen, however.<sup>665</sup> More recently, improvements in urinary urge incontinence and in sexual function were observed following a 12-week treatment with ospemifene in postmenopausal women with symptoms of overactive bladder syndrome.<sup>666</sup>

# Effect of SERMs on the Skeleton

These effects are discussed later in the chapter, in the section on osteoporosis.

## Tissue-Selective Estrogen Complex

The combination of an estrogen combined with a selective estrogen receptor modulator (SERM) is called a TSEC (tissue-selective estrogen complex). The idea is to gain the benefits of estrogen (improved vasomotor symptoms and improved BMD and reduced fracture risk) while mitigating potential for adverse effects of estrogen on certain end organs (such as the endometrium and the breast). A series of randomized controlled trials (SMART) have paired conjugated estrogen with a SERM, bazedoxifene (BZA), with the goal of achieving symptom benefit without the need for adding progestational agent to HT regimen in women who have a uterus, while allowing synergy of both agents on certain end organs such as the bone.<sup>667</sup> BZA belongs to the estrogen agonist-antagonist family of drugs. It has favorable effects on the bone and lipids, but does not affect the endometrium or the breast.<sup>668,669</sup> BZA in a dose of 20 mg daily decreased the risk of all clinical fractures in randomized clinical trials, with a potency comparable to other antiresorptive agents in postmenopausal women at high risk for fractures.<sup>670,671</sup> In a subgroup of women at higher risk for fractures, BZA had a reduced risk of nonvertebral fractures (50% reduction with 20 mg), compared with both raloxifene and placebo. Treatment for 2 years had no effect on mammographic breast density.<sup>672</sup> Furthermore, in the Selective Estrogens, Menopause, And Response to Therapy (SMART)-5 trial (using BZA paired with CEE), there was no increased incidence of breast density or tenderness when compared to CEE/MPA.<sup>673</sup> The results of these trials indicate that the effect of BZA on the bone should be comparable to that of estrogen and bisphosphonates.

BZA combined with conjugated estrogens effectively suppresses hot flashes, improves vaginal atrophy, prevents bone loss, and does not stimulate the endometrium or cause breast tenderness.<sup>668,673,674,675,676,677</sup> The combination of 20 mg BZA with CEE prevents endometrial hyperplasia and has an extremely high rate of amenorrhea (at least 80%).<sup>678,679</sup> Given BZA's antiestrogenic effects specific to the endometrium (even in the presence of CEE), the TSEC approach may be the future of HT given that it maximizes the benefits of HT and also minimizes harm. It also allows for the avoidance of a progestational agents. **The first TSEC to be approved by the FDA in the United States is Duavee.**

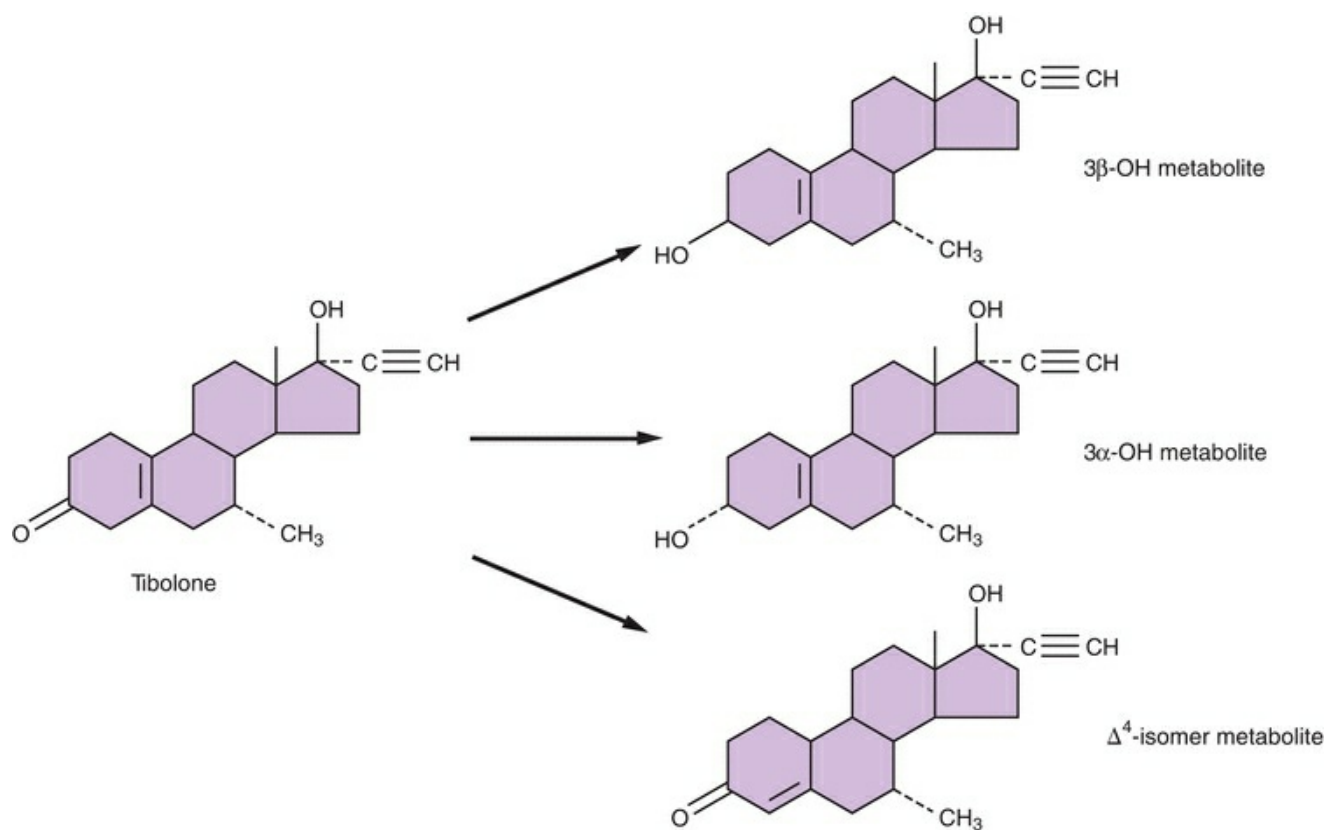
# TIBOLONE

---

Tibolone is marketed for menopausal HT in many countries throughout the world, but is not approved in the United States. It was first introduced in the Netherlands, the home country of its manufacturer Organon (now Schering-Plough), which initiated research on this product in the 1960s. Although tibolone was specifically developed as a drug to treat osteoporosis, the clinical performance of tibolone led rapidly to its approval for the treatment of menopausal symptoms as well as prevention of osteoporosis. Because of its unique metabolism, tibolone can exert different hormonal activities at different sites. It has beneficial effects on bone density, improves vasomotor symptoms, and does not have estrogenic effects on the endometrium.<sup>680</sup> However, there are concerns regarding its safety. Adverse effects of tibolone on breast tissue and increased stroke risk are described with its use, and overall it is felt to be less effective than estrogen-based HT.<sup>681</sup> Given these concerns, we do not recommend it as a first-line management approach to menopause.

# The Chemistry of Tibolone

Tibolone is structurally related to the 19-nortestosterone progestins that are used clinically in oral contraceptives; however, its activity depends on its metabolism. Tibolone {7- $\alpha$ ,17- $\alpha$ -17-hydroxy-7-methyl-19-norpregn-5(10)-en-20-yn-3-one} is metabolized among human and nonhuman primates into three biologically active metabolites (**Figure 17.12**); the 3 $\alpha$ -hydroxy (3 $\alpha$ -OH) metabolite and the 3 $\beta$ -hydroxy (3 $\beta$ -OH) metabolite have estrogen agonist properties, whereas the  $\Delta$ -4 ketoisomer has progestogenic and androgenic effects.<sup>682,683</sup> Although tibolone itself binds to the estrogen receptor, in vivo the activity of the 3-hydroxymetabolites is 100 times greater, with a greater affinity for the estrogen receptor-alpha than for estrogen receptor-beta.<sup>683</sup> The loss of the hydroxyl group at position 3 of the A ring eliminates estrogenic activity in the  $\Delta$ -4 isomer. The  $\Delta$ -4 isomer exerts its androgenic effects primarily in the liver and brain.



**FIGURE 17.12**

The conversion of tibolone into metabolites occurs chiefly in the liver and intestine. The metabolism of the parent compound is rapid and very near total, yielding mainly the 3 $\alpha$ -OH and the 3 $\beta$ -OH metabolites in the circulation; the level of the 3 $\alpha$ -OH metabolite is

threefold higher compared with the  $3\beta$ -OH metabolite.<sup>684,685</sup> Tibolone and the  $\Delta$ -4 isomer can be detected only at peak levels 2 hours after ingestion, and, even then, the levels are very low, at the limit of detection. The half-life of the metabolites that predominate in the circulation (the  $3\alpha$ -OH and  $3\beta$ -OH metabolites) is approximately 7–8 hours, and a steady state is attained by day 5.<sup>686</sup> Eating does not affect the metabolism, and tibolone can be taken at any time of the day.<sup>684</sup> The pharmacokinetics of tibolone are not affected by impaired renal function. There is a very weak effect of the metabolites on cytochrome P450 enzymes, and no interference is to be expected with coadministered drugs.<sup>685</sup> After the initial metabolism of tibolone, the products are rapidly sulfated, and more than 75% of the metabolites circulate as the sulfates to be activated by tissue sulfatases.<sup>685</sup>

Tibolone is available in two daily doses, 1.25 and 2.5 mg. There is considerable variability (about 30–40%) within and between subjects, but the 1.25- and 2.5-mg doses produce the same bioequivalence as measured by maximum levels and areas under the curve for the  $3\alpha$ -OH and  $3\beta$ -OH metabolites.<sup>684</sup> However, there are differences in clinical responses, which influence the choice of dose.

The metabolism of tibolone is not limited to the liver and intestine. Important effects are explained by specific local tissue metabolism. For example, the  $\Delta$ -4 isomer is primarily produced within the endometrium, binds to the progesterone receptor, and protects the endometrium from the agonist effects of the two estrogenic metabolites.<sup>685,686,687,688,689,690</sup>

# Effect of Tibolone on Menopausal Symptoms

Menopausal symptoms provide the main motivation for women to use postmenopausal hormonal therapy. Tibolone must perform well in this category in order for it to be an attractive option for clinicians and patients. Clinical studies have established without question that tibolone exerts an estrogenic beneficial impact on hot flushing and vaginal dryness. Appropriate studies have documented that tibolone in a daily dose of 2.5 mg is as effective as standard postmenopausal hormone regimens in treating hot flushing.<sup>691,692,693,694,695,696,697</sup> The 1.25-mg dose takes longer to be effective, and this dose also has a higher incidence of persistent flushing.<sup>698</sup> In addition, tibolone effectively treats the side effect of hot flushing associated with GnRH agonist therapy.<sup>699</sup> Fortunately, tibolone treatment provides an estrogenic effect on the vagina. Tibolone, 2.5 mg daily, relieves vaginal dryness and dyspareunia, and in most studies, tibolone is as effective as estrogen treatment.<sup>693,694,695,696,697,700,701,702,703</sup>

A decided advantage for tibolone can be found in studies examining sexuality. In prospective, randomized trials comparing tibolone with estrogen or estrogen-progestin therapy, tibolone has been associated with a better sexual response.<sup>694,697,704,705,706,707</sup> An increase in libido has been reported in studies comparing tibolone with placebo,<sup>703,708</sup> and the response has been greater than that with estrogen therapy, comparable to that associated with androgen treatment.<sup>709</sup> The overall effect has included an increase in sexual interest and sexual performance, specifically fantasies, arousal, and orgasm.

There are two possible mechanisms for tibolone's effect on sexuality: a direct androgenic effect of the  $\Delta$ -4 isomer and/or an increase in the circulating level of free testosterone. Tibolone is associated with a profound change in the circulating levels of SHBG, about a 50% decrease.<sup>703,710</sup> This is undoubtedly due to the  $\Delta$ -4 isomer and an androgenic effect on the liver. Tibolone treatment, therefore, produces a decrease in the concentration of total testosterone (bound and unbound) but a substantial increase in the amount of free, unbound testosterone. This hormonal profile is a striking contrast to that associated with estrogen therapy, which increases SHBG and decreases both total and free testosterone levels. The androgen side effects of acne and hirsutism, however, have not been reported with tibolone treatment.

When women who had been on tibolone for 10 years were compared with a matched group, the treated women were less clumsy, were less anxious in response to mild stress, and demonstrated better memory for facts, although there was no difference in memory for events and worse performance on sustained attention and planning.<sup>711</sup> Overall, tibolone exerts a positive effect on mood that is modest in impact.<sup>710,712</sup> However, this is an area in which it is not easy to achieve consistent effects, a problem

often due to the differences in measurement tools and definitions. The study of cognition is difficult because of the need to match treated and control groups for intelligence, age, occupation, education, and mental state (e.g., depression). Because of this difficulty, the literature reporting the effects of hormone therapy on cognition provides an inconsistent picture. This is further complicated by the sensitivity and appropriateness of the assessment tools that are used. This is an area that requires standardization and new approaches for research, not only for tibolone but for all pharmacologic treatments that affect the central nervous system.



# Effect of Tibolone on the Cardiovascular System

Consistent with reports of tibolone's effects on HDL cholesterol in postmenopausal women, tibolone-treated monkeys have much lower HDL cholesterol compared with control monkeys.<sup>713,714</sup> Although tibolone treatment resulted in lower circulating HDL cholesterol, coronary artery atherosclerosis extent in monkeys was not significantly different from the control group. Similar results were observed in the carotid arteries.<sup>714</sup> That observation prompted the question of whether the HDL cholesterol reductions noted among the animals treated with tibolone were associated with physiologically meaningful reductions in HDL cholesterol function. HDL cholesterol has a critical role in reverse cholesterol transport, the mechanism by which cell cholesterol (i.e., artery wall cholesterol) can be returned through the plasma to the liver for excretion.<sup>715</sup> Further, it has been found that cholesterol efflux capacity predicts the severity and extent of coronary artery disease in human patients.<sup>716</sup> Postmenopausal monkeys treated with tibolone had no reduction in cholesterol efflux.<sup>717</sup> This disassociation between reductions in circulating concentrations of HDL cholesterol and the lack of change in HDL cholesterol function suggests the likelihood that this may account in large part for the finding that coronary artery atherosclerosis was not increased or decreased in the monkey model.

Short-term clinical studies uniformly document that tibolone treatment, 2.5 mg/day, reduces HDL cholesterol levels in women by about 20%; however, there is also a reduction in total cholesterol (about 10%) and triglycerides (about 20%) and a slight decrease or no change in LDL cholesterol levels.<sup>705,718,719,720,721,722,723,724</sup> In women, therefore, tibolone does not increase LDL cholesterol, and the reduction in HDL cholesterol is less than that recorded in monkeys. In addition, tibolone decreases LDL cholesterol oxidation and produces a shift away from small dense LDL cholesterol (which is more atherogenic); both changes would be beneficial.<sup>724</sup> The potential harmful effects associated with reductions in HDL cholesterol are further balanced by tibolone-associated reductions in endothelin and lipoprotein(a), anti-ischemic effects detected in women with angina, and an improvement in insulin sensitivity.<sup>723,725,726,727,728</sup> In longer-term studies, HDL cholesterol levels did not come back to baseline at the end of 2 years of treatment, but did return to baseline at the end of 3 years.<sup>723,729,730,731</sup> And other studies have found that the decrease in HDL cholesterol is statistically insignificant.<sup>732,733</sup>

The recognition that reductions in HDL cholesterol are potentially harmful is based on the important roles for HDL cholesterol in the mediation of cholesterol movement from lipid-laden cells and inhibition of LDL cholesterol oxidation. However, the experimental results in the monkey model indicate that reductions in HDL cholesterol

concentrations are not directly paralleled by reductions in important HDL cholesterol functions. At least one reason for this lack of direct correlation is the complex nature of HDL cholesterol lipoproteins, a heterogeneous collection of particles that differ in their activities.<sup>734</sup> The overall change in HDL cholesterol levels will not reflect specific changes in particles that can affect specific biologic activities. Similar to results in the monkey model, a randomized trial in women demonstrated that significant reductions in HDL cholesterol levels (average 27%) caused by tibolone treatment, 2.5 mg/day, were due to a decrease in one subclass of HDL cholesterol particles, and measures of HDL cholesterol antiatherogenic functions (reverse cholesterol transport and inhibition of LDL cholesterol oxidation) were not impaired.<sup>728</sup> The study was limited by the short, 12-week duration of treatment; however, the findings are consistent with those obtained in the 2-year monkey experiment. These human results were confirmed and strengthened by a study of 68 postmenopausal women randomized to daily treatment for 3 months with either 2.5 mg tibolone or placebo.<sup>735</sup> Changes in HDL cholesterol were associated with an increase in hepatic lipase activity, an androgenic effect, again without impairing the ability of plasma to maintain cholesterol efflux.

Results in the monkey model are consistent with an overall neutral impact on the cardiovascular system.<sup>714</sup> A long-term (average of 7.5 years) follow-up of women treated with tibolone found no increase in carotid artery intimal-medial thickness and the number of atherosclerotic plaques, results that are consistent with the monkey model.<sup>736</sup> This neutral impact is further supported by failing to find any effect of tibolone on experimentally induced brachial artery dilation or on vascular resistance measured in the carotid and middle cerebral arteries.<sup>732,737</sup> On the other hand, a method studying venous dilation in the hand found an improvement in endothelium-dependent responses after tibolone treatment.<sup>738</sup> Myocardial infarction and heart failure have been reported to be associated with overactivity of the sympathetic component of the cardiac autonomic nervous system, and tibolone treatment decreases plasma levels of free fatty acids, an effect that results in an improved ratio of cardiac sympathetic tone to parasympathetic tone.<sup>739</sup> Another favorable effect connected to tibolone and its metabolites is a direct impact on endothelial cells that results in a beneficial decrease in endothelial-leukocyte adhesion molecules, another human finding similar to that in the monkey trial.<sup>740</sup>

The OPAL (Osteoporosis Prevention and Arterial effects of tibolone) study was a 3-year, randomized, double-blind trial in six U.S. centers and five European centers, treating 866 postmenopausal women with either 2.5 mg tibolone daily, 0.625/2.5 mg daily of conjugated estrogens/medroxyprogesterone acetate, or placebo.<sup>741</sup> The arterial endpoint of the study was carotid intima-media thickness measured by ultrasonography every 6 months. Both the tibolone-treated group and the estrogen-progestin-treated

group demonstrated an increase in intima-media thickness over the time period of the study, at a rate significantly greater than the placebo group, leading to the conclusion that both tibolone and estrogen/progestin treatment increased atherosclerosis compared with the placebo group.

In the OPAL trial, European women differed from American women in multiple ways: higher lipids, higher blood pressure levels, and more smokers. Hysterectomized women were excluded in the United States but not in Europe (28% of the study population). The overall mean results, indeed, indicated a difference comparing both treatment groups to placebo. But in the European women, atherosclerosis, measured by intima-media thickness, improved in the placebo group, making it easy to calculate a significant difference compared to the treated groups. In American women, there were no differences comparing the three treatment groups; all demonstrated progression of thickness. Thus, the overall conclusion was inordinately influenced by the results in the European women. The investigators could not explain these differences. Unfortunately, the OPAL trial did not achieve its goal of providing robust data on cardiovascular effects, due to the older age of the women and the notably different results in American and European women. There continues to be good reason to believe that tibolone has a neutral effect on the cardiovascular system. In addition, tibolone does not adversely affect the blood pressure in women with established hypertension.<sup>721</sup>

A case-control study assessed the risk of VTE in a very large population of postmenopausal women (23,505 cases and 231,562 controls) derived from the U.K. General Practice Research Database.<sup>742</sup> No increase in risk was observed with the current use of either tibolone or transdermal estrogen compared with a significant increase associated with the current use of oral estrogen.

# Effect of Tibolone on Diabetes

The administration of tibolone, 2.5 mg/day, to older women with type 2 diabetes mellitus produced no significant changes in the lipid profile.<sup>743</sup> Tibolone treatment is associated with an increase in insulin sensitivity in women with insulin resistance, although some have reported no effect in normal women.<sup>720,728,744,745</sup> Therefore, tibolone is an attractive option for postmenopausal women with diabetes mellitus.

## Effect of Tibolone on the Uterus

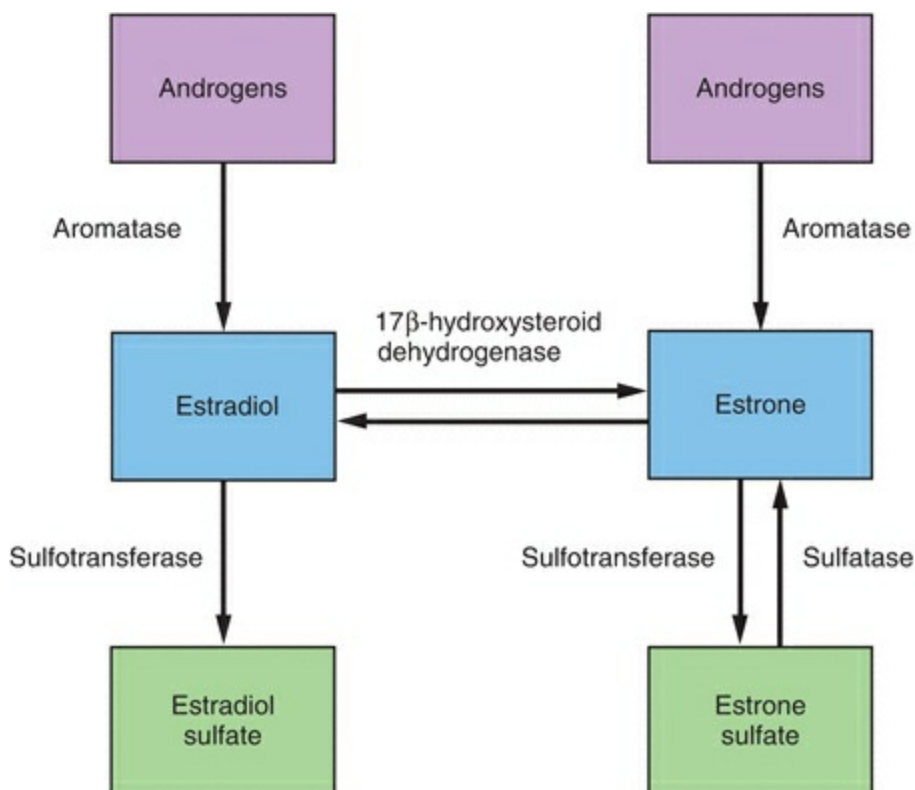
Tibolone does not stimulate endometrial proliferation. This is because the predominant if not exclusive tibolone metabolite produced within the endometrium is the  $\Delta$ -4 isomer, which binds to the progesterone receptor and protects the endometrium from the agonist effects of the two estrogenic metabolites.<sup>687,688,689,690</sup> This protective effect has been documented in long-term (up to 8 years) human studies.<sup>689,690,693,701,702,746,747,748</sup> Isolated cases of endometrial proliferation have been reported, for example, 4 of 150 women treated with 2.5 mg daily for 2 years.<sup>749</sup> In a 5-year follow-up, 47 of 434 women experienced bleeding, and of these, 11 had endometrial polyps or fibroids, but there were 2 with simple hyperplasia and 2 with endometrial carcinoma in situ.<sup>750</sup> This underscores the standard clinical principle to investigate persistent vaginal bleeding in any postmenopausal woman. In the major U.S. clinical trial, three cases of endometrial cancer were observed, but, in each case, preexisting carcinoma was later detected when the initial biopsy samples were more extensively examined.<sup>723</sup> Nevertheless, a second large 2-year trial was conducted, the THEBES study, and no endometrial hyperplasia or cancer occurred in the tibolone-treated groups.<sup>751</sup>

The reported breakthrough bleeding rates with tibolone treatment have been comparable to treatment with combined, continuous estrogen-progestin therapy,<sup>694,696,719,746</sup> but well-designed comparison clinical trials indicate that the rate is less with tibolone.<sup>695,697,703,752,753</sup> In addition, amenorrhea is achieved more rapidly; 90% of tibolone-treated women are amenorrheic by 6 months.<sup>695,750,754</sup> Bleeding is less in older women and can be greater with the 2.5-mg dose compared with the 1.25-mg dose, but the difference is too small to be detected in some studies.<sup>698,723,755</sup> Importantly, a lack of correlation has been observed between bleeding and endometrial thickness measured by ultrasonography.<sup>755,756</sup> **This again emphasizes the need to biopsy tibolone-treated women with persistent bleeding.**

Careful evaluations of women with fibroids who have been treated with tibolone have revealed no evidence of myoma growth, with up to 3 years of follow-up.<sup>757,758,759</sup> Furthermore, add-back treatment with tibolone effectively prevents flushing and bone loss and does not impair the fibroid response to therapy with GnRH analogs.<sup>760</sup>

# Effect of Tibolone on the Breast

The breast is a complicated estrogen factory. The breast tissue, normal and abnormal, contains all the enzymes necessary for the formation of estrogens (sulfatase, aromatase, and  $17\beta$ -hydroxysteroid dehydrogenase) and the conversion of estrogens into their sulfates (sulfotransferase) (Figure 17.13). Estrone sulfate concentrations are high in the breast (higher than in plasma) and even higher in cancer tissue. This state is achieved in postmenopausal women with very low systemic levels of estrogen, indicating that a local mechanism is operative.



**FIGURE 17.13**

The major pathway of estrogen synthesis in human breast tumor cells is by conversion of estrone sulfate to estrone by estrone sulfatase, a pathway that is more important than the aromatase pathway.<sup>761</sup> Aromatase is an enzyme complex that produces the irreversible conversion of androgens to estrogens. The location of aromatase activity is predominantly in the stromal tissue of the breast. Comparing normal to tumor tissue, the levels of estrone sulfate and estradiol were higher in the tumor tissue.<sup>762</sup> Sulfatase activity is higher (130–200 times) than aromatase activity in all breast tissues examined, and the sulfatase and aromatase activity was higher in the tumor tissue than in normal

tissue. Thus, estrogen concentrations in the breast are higher in women with breast cancer, and formation of estradiol from sulfated estrogen is the primary pathway. Most importantly, this increase in estrogen activity is independent of the estrogen receptor status of the tissue.

Tibolone and its metabolites inhibit estrone sulfatase and 17 $\beta$ -hydroxysteroid dehydrogenase in normal stromal cells and in hormone-dependent breast cancer cells (MCF-7 and T-47D).<sup>763,764,765,766</sup> This inhibits conversion of estrone sulfate to estradiol. In addition, tibolone and its 3-hydroxymetabolites increase the conversion of estrone back to estrone sulfate by increasing the activity of sulfotransferase.<sup>767</sup> Tibolone and all three metabolites inhibit the conversion of estrone to estradiol by 17 $\beta$ -hydroxysteroid dehydrogenase.<sup>764</sup> Although these effects resemble progestin activity, tibolone is more potent. Tibolone increases aromatase activity in stromal cells but only at high concentrations that are beyond in vivo levels.<sup>765</sup> These tibolone-induced enzyme changes would lower the active estrogen concentrations in breast tissue.

In the rat and mouse breast cancer models (cancer induced by 7,12-dimethylbenz[a]anthracene, DMBA), tibolone exerts protective effects to the same degree as tamoxifen.<sup>768</sup> However, tibolone is not antiestrogenic and does not inhibit aromatase. Therefore, the mechanism is explained by the enzyme effects summarized previously, inhibition of sulfatase and 17 $\beta$ -hydroxysteroid dehydrogenase and stimulation of sulfotransferase to increase the production of inactive sulfates.<sup>765</sup> In addition, tibolone increases cellular differentiation and stimulates apoptosis, at least with normal breast cells in vitro.<sup>769</sup> An increase in apoptosis is an action of the parent tibolone and its  $\Delta$ -4 isomer. Thus, tibolone acts like progestins and weak androgens in breast cell line studies examining proliferation, differentiation, and apoptosis.

Tibolone and its metabolites do not display the same activity directed toward the sulfatase enzyme in all tissues. Strong inhibition of sulfatase is a major feature in breast cells, but tibolone and its metabolites inhibit sulfatase only moderately in the endometrium (contributing to an antiestrogenic action) and provide no inhibition in the bone (allowing a greater estrogenic impact).<sup>770</sup>

Postmenopausal hormone therapy increases breast density on mammography in about 10–20% of estrogen users and about 20–35% of estrogen-progestin users, an effect that occurs within the first months of treatment. In contrast, tibolone does not increase breast density and causes far less mastalgia than that seen with estrogen treatment.<sup>695,707,723,753,771,772,773,774,775</sup> It is logical to conclude that these favorable responses are a consequence of the tibolone effects on the breast tissue enzymes involved in local estrogen production.

The Livial Intervention following Breast cancer: Efficacy, Recurrence, And

Tolerability Endpoints (LIBERATE) trial was a multinational, placebo-controlled, randomized study of women with vasomotor symptoms who had had breast cancer surgically treated within the previous 5 years.<sup>776</sup> The study was designed to demonstrate that tibolone was superior to placebo, but when the drug monitoring safety board notified the sponsor that there appeared to be an excess of breast cancers in the treated group, the trial was canceled on July 31, 2007, 5 months before its scheduled end. The median duration of participation and treatment was about 3 years, with a wide range from a few weeks to almost 5 years. The participants used a variety of adjuvant treatments, mostly tamoxifen, 66.8%; 6.5% used aromatase inhibitors. The dose of tibolone was 2.5 mg daily. Final numbers for analysis were 1,556 women in the treated group and 1,542 in the placebo group. The women ranged in age from under 40 to 79, with a mean age of 52.7 years. 57.8% had positive lymph nodes and 70% had a tumor stage of IIA or higher. Estrogen receptor status was known in 2,808 women in whom the tumors were estrogen receptor positive in 77.8%. In the intent-to-treat analysis, the hazard ratio for recurrent breast cancer in the tibolone-treated women was 1.40 (CI = 1.14–1.70). The absolute risk for tibolone was 51 cancers per 1,000 women per year and 36 in the placebo group. The increase occurred only in women with estrogen receptor–positive tumors. There was no difference in mortality rates between the two groups during the 5-year study period. There were no differences in cardiovascular events or gynecologic cancers, and not surprisingly, vasomotor symptoms, quality of life measures, and bone density improved with tibolone treatment.

How do the LIBERATE results that indicate an estrogenic action of tibolone in breast cancer survivors jibe with the literature indicating that tibolone exerts a nonestrogenic effect on breast tissue? Indeed, it was realistic to expect tibolone to have a salutary effect on the breast. It is well documented that the breast responds to tibolone with less stimulation compared with estrogen, judged by changes in mammographic breast density and the characteristics of tissue obtained by fine-needle aspiration. In the LIFT clinical trial (discussed under bone) that had vertebral fractures as the primary endpoint and breast cancer as a secondary endpoint, the risk of breast cancer after 3 years was significantly 68% reduced with tibolone treatment, although the dose was lower, 1.25 mg daily.<sup>777</sup>

The previous literature documenting beneficial actions of tibolone on the breast reflected, however, the impact of tibolone on normal breast tissue, and tibolone's activity to lower local bioactive estrogen levels in target tissues might be lost in cancer cells. The contrary results in the LIFT trial could reflect its older population of women at high risk for fractures, a population that also differed by having lower body weights, no history of tamoxifen treatment, and lower risk factors for breast cancer.

Although the LIBERATE trial may apply to all breast cancer survivors, speaking strictly in a scientific sense, the results were derived mainly from tamoxifen users with



10-fold fewer users of aromatase inhibitors. The possibility that estrogen or tibolone would interfere with the beneficial effects of tamoxifen or aromatase inhibitors has always been one of the objections to treating breast cancer survivors with estrogenic hormones. In a subgroup analysis of the LIBERATE trial, the group of women who had used aromatase inhibitors had a greater risk of recurrent breast cancer compared with tamoxifen; however, the confidence interval was wide because of relatively small numbers. Possibly, the estrogenic effect of tibolone would be more pronounced on an occult breast cancer in estrogen-depleted tissue compared with tissue where tamoxifen was bound to the estrogen receptor and prevented estrogenic stimulation. We don't know if the LIBERATE data are meaningful for future treatment regimens. Nevertheless, **until there are new data, the use of tibolone in women with a history of breast cancer remains relatively contraindicated.**

# Effect of Tibolone on the Bone

These effects are discussed later in the chapter in the section on osteoporosis.

## Key Points: Tibolone

- Tibolone is an appropriate choice for hormonal therapy, suitable for many postmenopausal women.
- The standard dose of tibolone for many years was 2.5 mg daily, but the clinical trials support the use of the lower dose, 1.25 mg daily, with no major loss of efficacy.
- Because of its unique and varied metabolism, tibolone has different actions in different tissues, which provide an overall favorable risk-benefit profile.
- Tibolone treats menopausal symptoms, including hot flushes and vaginal dryness, as effectively as estrogen therapy and, most importantly, improves sexual response.
- Endometrial safety and prevention of bone loss (discussed in under the section on osteoporosis of this chapter) are comparable to that achieved with continuous, combined estrogen-progestin regimens and with a lower rate of breakthrough bleeding.

The sum of the various biologic effects of tibolone and its metabolites on the cardiovascular system should neither increase nor decrease the risk of coronary artery disease. Thus far, there has been no indication for an increased risk of VTE, but this is a potential side effect that requires further epidemiologic studies. Tibolone does not stimulate the proliferation of breast cells and affects enzyme activity in the breast to lower breast tissue concentrations of active estrogen. Tibolone does not increase breast density on mammography and does not increase the frequency of mastalgia. The reported increased risks of breast cancer and endometrial cancer in observational studies very likely represent “preferential prescribing” of tibolone in Europe.<sup>778,779</sup> Women prescribed tibolone in Europe more often had chronic breast disease, a personal history of breast cancer, previous dysfunctional uterine bleeding, hypertension, and previous uterine operations. Most importantly, more women prescribed tibolone had a history of previous treatment with unopposed estrogen. Thus, clinicians were more likely to prescribe tibolone to women they believed were at higher risks for these two cancers, and this would

**yield higher rates in treated groups compared with control groups.**

# NON-HORMONAL TREATMENT OPTIONS FOR VASOMOTOR SYMPTOMS

---

The treatment of choice for vasomotor symptoms (hot flashes and night sweats) is hormone therapy (HT). However, there exist a substantial number of women who either cannot, should not, or will not accept HT. Pharmacologic non-hormonal options for managing vasomotor symptoms are listed in [Table 17.10](#).

## TABLE 17.10 Drugs for Hot Flushing—Randomized Clinical Trial Results

<b>Drug</b>	<b>Dose</b>	<b>Reduction in Flushing</b>
Citalopram (Celexa) placebo	20 mg/day	50%, same as placebo
Fluoxetine (Prozac)	20 mg/day	50%, same as placebo
Sertraline (Zoloft)	50,100 mg/day	40%, same as placebo
Paroxetine (Paxil)	12.5 mg/day	62%
	25 mg/day	65%
Venlafaxine (Effexor)	37.5 mg/day	37%
	75 mg/day	61%
	150 mg/day	61%
Desvenlafaxine succinate (Pristiq)	100 mg/day	64%
Gabapentin (Neurontin)	900 mg/day	50%
Pregabalin (Lyrica)	150 mg/day	65%

Clonidine, bromocriptine, and naloxone given orally are only partially effective for the relief of hot flushes and require high doses with a high rate of side effects such as drowsiness and dry mouth. Bellergal treatment (a combination of belladonna alkaloids, ergotamine tartrate, and phenobarbital) is slightly better than a placebo and a potent

sedative in the short term; however, one study documented a similar response with Bellergal and placebo after 8 weeks.<sup>780,781</sup> Veralipride, a dopamine antagonist that is active in the hypothalamus, is relatively effective in inhibiting flushing at a dose of 100 mg daily, but is associated with major side effects, including mastodynia and galactorrhea.<sup>782,783,784</sup> Vitamin E, 800 IU daily, is barely more effective than placebo.<sup>785</sup> Dong quai, ginseng, black cohosh, isoflavones (including soy protein), yoga, and acupuncture all have little clinical difference compared with placebo treatment.<sup>786,787,788,789,790,791,792,793,794,795,796</sup> Clonidine (given as a patch or orally at 0.1 mg/day) is only partially effective for the relief of hot flushes and has a high rate of side effects such as drowsiness and dry mouth.<sup>797,798</sup> Medroxyprogesterone acetate (10–20 mg daily) and megestrol acetate (20 mg daily) are also effective (as effective as estrogen), but concerns regarding exogenous steroids, especially in patients who have had breast cancer, would apply to progestins as well.<sup>799,800,801</sup>

In the last few years, SSRIs (Selective Serotonin Reuptake Inhibitors), and SNRIs (Selective Norepinephrine Reuptake Inhibitors) have gained a reputation for significant efficacy in treating hot flushing. The drugs that have been studied include citalopram (Celexa), fluoxetine (Prozac), sertraline (Zoloft), paroxetine (Paxil, Brisdelle), and SNRIs, venlafaxine (Effexor) and desvenlafaxine succinate (Pristiq). In addition, antiseizure medications, gabapentin (Neurontin) and pregabalin (Lyrica), have been demonstrated to reduce vasomotor symptoms (see [Table 17.10](#)).

Paroxetine is FDA approved for the treatment of hot flushes. In a randomized control trial comparing low-dose paroxetine to placebo for treatment of hot flushes, treatment with paroxetine had a statistically significant reduction in vasomotor symptoms compared to placebo.<sup>802</sup> However, it is less effective than HT in relieving vasomotor symptoms and should be reserved for use in those women who have a contraindication to HT.

Venlafaxine was studied in breast cancer survivors; although the optimal dose was 75 mg, an appreciable response with 37.5 mg indicated that it would be worthwhile to begin treatment with the lower dose.<sup>803,804,805</sup> The response was very rapid, within days, and therefore the dose can be increased in 1–2 weeks. The main side effects were mouth dryness, anorexia, nausea, and constipation. The efficacy of venlafaxine was demonstrated to be the same in women taking or not taking tamoxifen. Desvenlafaxine succinate is a metabolite of venlafaxine and equally effective as the parent compound.<sup>806,807</sup> **The effects of citalopram, fluoxetine, and sertraline are no more effective than placebo, about a 50% reduction in short-term trials.**<sup>808,809,810,811,812</sup>

Gabapentin (Neurontin) is a  $\gamma$ -aminobutyric acid analog that has been used for seizures since 1994. It is also effective for migraine headaches, tremors, and panic

disorder. In a gabapentin clinical trial, 67% of the treated women experienced more than a 50% reduction in flushes at week 12, compared with 38% in the placebo group.<sup>813</sup> The most common side effects were somnolence (20%) and dizziness (13%). Peripheral edema occurs occasionally because of an induced decrease in serum protein. The potency of this agent appears to be more modest than the SSRIs in a dose of 900 mg/day.<sup>814,815</sup> Side effects are common at higher doses, and further studies are needed to compare gabapentin to HT.<sup>816,817</sup>

Pregabalin (Lyrica), a more potent form of gabapentin, is an anticonvulsant drug that has been used in doses of 150–300 mg daily to treat anxiety and neuropathic pain, for example, diabetic neurogenic pain, pain after shingles, and fibromyalgia. Side effects include dizziness, drowsiness, visual disturbances, tremor, weight gain, and a decrease in libido. In a phase III randomized trial, a dose of 75 mg b.i.d. (the recommended dose because of more side effects with higher doses), hot flushing was reduced by 65% after 6 weeks of treatment, an impact that was only 15% greater than placebo.<sup>818</sup> Although the data are limited to this short-term, small clinical trial, the effect of pregabalin appears to be comparable to gabapentin.

**The SSRIs are a logical choice if HT is contraindicated or not accepted by patients, although the reduction in hot flushing is considerably less than what can be achieved with estrogen treatment.** It is worth trying to titer the dose down to its lowest effective level because of a bothersome incidence of decreased libido. In addition, clinical experience indicates that it is best to slowly titrate upward to the recommended dose and, likewise, to wean the patient slowly when discontinuing treatment. SSRIs are effective for flushing secondary to both tamoxifen and hypoestrogenemia, and the efficacy is similar in women with and without breast cancer.<sup>819</sup> **An added advantage of the SSRIs is the fact that the clinical studies have also reported improvements in depression, anxiety, and sleep. Gabapentin is useful in those with difficulty sleeping, while clonidine may be more beneficial in women who also have hypertension.**

**Caution is advised when considering SSRIs in women with a history of breast cancer being treated with tamoxifen.** Tamoxifen is converted to an active metabolite by enzymes that are inhibited by certain SSRIs. Paroxetine coadministration decreases plasma concentrations of the active tamoxifen metabolite.<sup>820,821</sup> A lesser effect is associated with fluoxetine and sertraline. In a retrospective cohort study, only paroxetine use during tamoxifen therapy was associated with an increased risk of death due to breast cancer.<sup>822</sup> **Paroxetine, fluoxetine, and sertraline are therefore best avoided in women with a history of breast cancer who are being treated with tamoxifen.**

# BIOIDENTICAL HORMONES

---

Publication of the WHI Hormone Trials was followed by a period of much confusion and concern regarding safety of prescription HT. In the wake of both prescriber and patient distrust of HT, an upsurge of interest in bioidentical hormones occurred. Bioidentical hormones have since garnered much interest from the lay public, as well as generated much political, financial, and legal conflict. Bruce Patsner, research professor in the Health Law and Policy Institute at the University of Houston Law Center, has written what is, in our view, a masterful analysis of the problem, with suggestions for its resolution.<sup>122</sup>



# The History of the Conflict

The operations of a pharmacy are regulated in the individual states by state boards of pharmacy, in a system similar to the regulation of medical practice. The first federal law regulating drugs, the Federal Food, Drug, and Cosmetic Act, was passed in 1938, at a time when most drugs were compounded according to a doctor's prescription. The American Pharmacists Association defines pharmacy compounding as the preparation of a prescription drug that is "individualized" to the needs of the patient. This changed after World War II with the development and growth of the pharmaceutical industry. The Kefauver-Harris Amendment in 1964 extended the role of the Food and Drug Administration (FDA) to include safety and efficacy.

In the 1990s, the FDA began to regard the drugs coming from compounding pharmacies as falling under the "new drug" regulations, and therefore, the FDA had jurisdiction over the marketing and promotion of those drugs. The pharmacy world was immediately challenged; there was no way that an individual pharmacy could carry out the kind of clinical studies required for the approval of new drugs. Thus, the pharmacists immediately realized that all compounded drugs would be illegal. At the same time, the FDA was a bit ambivalent, acknowledging that there were examples where the individual needs of a patient required the compounding of a drug, for example, the creation of a liquid preparation when none was available. This was before compounding took to the Internet for marketing and promotion.

In 1992, the FDA issued its Compliance Policy Guide on Compounding, reserving a right for "selective enforcement," as a compromise between believing it was correct in assuming that compounded drugs represented new drugs and admitting that some patients required compounding. The pharmacy profession immediately rejected the idea that the FDA had any regulatory jurisdiction over pharmacies. The 1997 Food and Drug Modernization Act attempted to clarify the situation. An amendment was added to the existing laws stating that compounded drugs were not "new drugs," but at the same time, the 1997 act prohibited the marketing of compounded drugs.

The pharmacy profession sued the FDA, arguing that a restriction on advertising and promotion of compounded drugs was unconstitutional, a restriction of free speech. The District Court ruled against the FDA in 1999. The FDA appealed and lost again in the ninth Circuit Court of Appeals, which further invalidated the entire 1997 act. In 2002, the U.S. Supreme Court upheld the Circuit Court decision.

The FDA issued a new Compliance Policy Guide in 2002, stating that selective enforcement would hinge on three major factors: (1) a potential adverse effect of a drug, (2) whether drugs were compounded from non-FDA-approved components, and (3) whether compounded drugs were similar to drugs already removed from the market for safety reasons. At this point, the FDA affirmed that it did not want to infringe on the

traditional practice of compounding, the preparation of a drug according to a doctor's prescription to fit an individual patient's requirements.

Wyeth Pharmaceuticals filed a Citizen Petition with the FDA in October 2005 requesting that the FDA take action against several compounding pharmacies that were primarily Internet-based. The Petition's major allegation was that these pharmacies were essentially manufacturing new drugs and should be subject to new drug regulations. On January 9, 2008, the FDA announced it would take action against seven pharmacies providing prescription bioidentical hormones and issued warning letters that potentially could be followed by seizures of drugs and injunctions against production.

The FDA would like to regard compounded drugs as "new drugs," but the legal precedent has now been set by the courts: compounded drugs are not "new drugs." This was reaffirmed in a 2006 decision in the U.S. District Court for Texas. The FDA would further like to regard the giant compounding pharmacies, especially those operating over the Internet, as manufacturers, like pharmaceutical companies, but again, the court decisions have prevented the FDA from requiring compounding pharmacies to meet "new drug" standards. The "new drug" argument doesn't work.

"Bioidentical" and "natural" are often used in concert. Strictly defined, to meet the definition of bioidentical, the hormones must reflect the endogenous milieu (i.e., the right balance of estrone, estradiol, and estriol, the three endogenous estrogens) and natural progesterone (the progestational agent synthesized by the ovarian corpus luteum after ovulation) and right levels and ratio of circulating androgens (testosterone, androstenedione, and DHEA). The formulations that are available as bioidentical are created in compounding pharmacies and can contain several of the aforementioned hormones, but neither the regimens nor the formulations are standardized. Furthermore, batch-to-batch variability in dosage is inherent.<sup>561</sup> The term bioidentical holds marketing value, erroneously implying greater safety and better efficacy. The situation is further complicated because consumers assume that the marketed formulation offers better efficacy and safety. This, however, is not the case as these compounded hormones are not subject to the same regulations as approved HT nor are there studies that have demonstrated long-term safety or better efficacy in comparison to the approved "natural" formulations.<sup>823</sup> The problem is that compounding pharmacies are not required to compare the formulation with the performance of an approved product, nor is there any way for a patient to be assured that the dosage is correct (that the drug contains what it is supposed to contain). Thus, there are no randomized controlled trials demonstrating safety and efficacy, let alone superiority to the approved formulations.<sup>823</sup>

Lay proponents of bioidentical compounded hormones often propose testing of salivary hormone levels to guide dosing of compounded formulations. Assessments of

this approach by researchers, as well as organizations such as the American College of Obstetricians and Gynecologists and the Endocrine Society, have concluded that the variations in salivary sex steroid levels from individual to individual and from specimen to specimen preclude clinical interpretation.<sup>561,824,825,826</sup> For the majority of patients, laboratory testing is not necessary in hormone decision-making. Furthermore, given the lack of scientific data demonstrating safety, the use of bioidentical hormones over approved HT regimens is not recommended.<sup>827</sup>

# A Better Approach

The American Pharmacists Association and the National Association of Boards of Pharmacies define compounding as the steps required in order to provide a drug in response to a clinician's prescription according to an individual patient's needs and the preparation of drugs in anticipation of a demand. Therefore, there are three people involved: the patient, the clinician, and the pharmacist. This is in contrast to the production of large amounts of a drug for a national market of unknown users. **The American Pharmacists Association says that if an FDA-approved product is commercially available that meets a patient's needs, it should be the drug provided.**

The key to the position of the pharmacists is the contention that there are circumstances, decided by the patient, that make the use of commercial products not a good choice. This seems reasonable, but it is also reasonable that this decision requires the involvement of the clinician because ultimately a prescription is still required. The traditional view of compounding, therefore, is one of personal relationships with patient, clinician, and pharmacists. This becomes a totally different story when a large Internet pharmacy responds to thousands of prescriptions with no knowledge of the patients. What happened to the "individualization" aspect of compounding? Is it practicing medicine by the pharmacy to have a registered clinician employed by the pharmacy to interpret hormone levels and adjust doses?

Clinicians are appropriately frustrated by the claims made that bioidentical compounded drugs have greater efficacy and safety. Bruce Patsner argues that it should be accepted that bioidentical drugs from the big compounding pharmacies do not meet the definition of compounding supported by the pharmacist's own organization, the American Pharmacists Association—a personal relationship of patient, clinician, and pharmacist addressing an individual's needs.<sup>828</sup> The FDA can argue that the big operations are not legitimate compounding, but big commercial operations directed to unknown consumers.

Patsner also argues that the most vulnerable point is the false safety and efficacy claims. The contention should not be that the safety and efficacy claims are inaccurate, because the pharmacies can always compose their words to avoid legal assaults. The point of emphasis should go back to the pharmacist's published credo: if a commercial, approved product is available to meet the patient's needs, a compounded product is not indicated. Replacing a commercial product with a "natural," untested, unregulated product is not the same thing as prescribing a compounded product when no commercial product will meet the individual's needs.

Patsner summarizes his argument by saying that the large compounding pharmacies are not true compounders because they advertise and promote their products as

replacements for commercially available, approved, and tested drugs and that the attempt at “individualization” uses an unsubstantiated method that marginalizes clinicians.<sup>828</sup>

The bioidentical hormones and the various commercial female hormone products are produced by pharmaceutical companies using similar methods that start from the same raw material, usually soy or yams. Some of the commercial products available consist of estradiol, testosterone, and progesterone, the exact same steroid drugs provided by compounding pharmacies. A major difference between the commercial products and products from compounding pharmacies is the important fact that commercial products are federally regulated and tested for purity and potency; compounding pharmacies have not been regulated in this fashion.

The compounded estrogen formulations that contain combinations of estrone, estriol, and estradiol contain sufficient estradiol to produce the same biologic effects associated with commercial preparations. There are no clinical studies documenting that these combinations confer better results or safety. Whether the presence of estriol reduces the risk of breast cancer has not been tested in appropriate clinical studies. Case-control data indicate that estriol used without a progestational agent increases the risk of endometrial cancer; thus, its biologic behavior is similar to that of other estrogens.<sup>829</sup>

**Custom-compounded formulations have not been proven to be safer or better and therefore should not be regarded as having similar risks and benefits as commercial products. Claims for custom-compounded products have not been scientifically tested. Tailor-making a hormone therapy regimen according to salivary testing is an appealing idea that has not been addressed scientifically, and given the variability in salivary hormone levels, it is unlikely that clinical studies would yield useful information. Recommendations promoting customized compounded formulations individualized to salivary sex steroid hormone profiles thus should be viewed with cynicism as the salivary hormone levels vary widely between individuals and from measurement to measurement within the same individual. Books and pharmacies promoting their own products should similarly be viewed with caution. Patients who wish to use products similar to endogenous hormones should be made aware of the content of available commercial formulations and reassured that marketed and approved 17 $\beta$  estradiol and micronized progesterone formulations are indeed reliable bioidentical representatives. Books and pharmacies promoting their own products should be viewed with caution; don't confuse marketing with science.**

# ALTERNATIVE THERAPIES

---

The business of selling alternative therapies is now a worldwide phenomenon. The promotion of many of these treatments relies on a network of alternative providers, authors, and compounding pharmacies. Why are herbs and botanicals not regulated? In the United States, the Dietary Supplement Health and Education Act of 1994 deregulated the industry by classifying dietary supplements as neither foods nor drugs. Thus, manufacturers of dietary supplements are not required to demonstrate that they are safe or effective. In addition to a lack of regulation, there are many other problems associated with herbs and botanicals. The products vary in the amount and purity of active ingredients; indeed, products on the shelf often are adulterated and contaminated with drugs or metals.<sup>830</sup> And very importantly, there is enormous variation in the plants themselves because of genetic, harvest year, and processing differences and in individual metabolism of the products.

# Alternative Therapies for Vasomotor Symptoms: Phytoestrogens

“Phytoestrogens” is a descriptive term applied to nonsteroidal compounds that have estrogenic activity or are metabolized into compounds with estrogen activity. Phytoestrogens are classified into three groups: isoflavones, lignans, and coumestans.<sup>831,832</sup> They are present in about 300 plants, especially legumes, and bind to the estrogen receptor. Soybeans, a rich source of phytoestrogens, contain isoflavones, the most common form of phytoestrogens, mainly genistein and daidzein, and a little glycitin.

Examples of phytoestrogens:

- **Isoflavones (genistein, daidzein, glycitin): soybeans, lentils, chickpeas (garbanzo beans), and red clover**
- **Lignans: flaxseed, cereals, vegetables, and fruits**
- **Coumestans: sunflower seeds and bean sprouts**

Isoflavones exist in plants bound as glycoside conjugates attached at the 3 position, called glycones. The carbohydrate component requires gut bacteria to remove the sugar moiety to produce active compounds, the aglycones. Individual variability in gastrointestinal microflora, as well as absorption, influences the bioavailability of isoflavones. Biochanin and formononetin are methylated precursors that are metabolized to genistein and daidzein. Red clover and lentils contain significant amounts of these precursors. The isoflavones are in the active, deconjugated forms in fermented soy foods like miso and tempeh. The concentration of isoflavones in tofu is highly variable.

The phytoestrogens are characterized by mixed estrogenic and antiestrogenic actions, depending on the target tissue and local estrogen concentration. Variations in activity may also be due to the fact that the soy phytoestrogens have a greater affinity for the estrogen receptor- $\beta$  compared with estrogen receptor- $\alpha$ , although the affinity for the beta-receptor is still only 35% that of estradiol.<sup>833</sup> Despite a low affinity for the alpha-receptor, circulating levels many times that of steroidal estrogens produce the potential for biologic activity.

You can eat soybeans every day and never see a bean. Soybeans are defatted to produce soy flour. Soy flour is then prepared to remove the carbohydrates. Ninety-five percent of soy flour is toasted and used as animal feed. Alcohol washing is used to get a taste-free product, but alcohol extraction removes the phytoestrogens.<sup>834</sup> SUPRO, known as “isolated soy protein,” from Protein Technologies International, the major supplier for commercial products and research, is extracted by aqueous washing and

retains the isoflavones.

The reason why most of the soybean crop is devoted to animal feed is because what is left after removing lipids is totally bland. The solution is to mix soybeans with other foods, for example, beans and soups. Unfortunately, they require standing in water for about 12 hours and simmering for 2–3 hours to be cooked. The average Japanese intake of isoflavones is about 50 mg/day.<sup>835</sup> The rest of Asia has an average consumption of about 25–45 mg/day, and Western consumption is less than 5 mg/day.<sup>836,837</sup>

Equol is the active metabolite in all phytoestrogens. Interestingly, not all individuals have the ability to convert phytoestrogens into their active metabolite.<sup>797</sup> Given conflicting results, regarding efficacy, routine use is not recommended, especially with data from a Cochrane review demonstrate no conclusive evidence.<sup>797,838</sup> Furthermore, phytoestrogens are **generally** contraindicated in women with hormone-dependent **cancers**, thromboembolic disease, or **cardiovascular** disease, as the amount of estrogen from consumption of these products is not known.<sup>797</sup>

## Other Alternative Therapies for Flushing

### Red Clover

Promensil is an extract of red clover (*Trifolium pratense*) containing formononetin, biochanin, daidzein, and genistein. Formononetin and biochanin are metabolized to daidzein and genistein, respectively. Red clover is a legume used to enrich nitrogen levels in soils. Promensil is produced by Novogen in Australia and marketed by Solvay in the United States. A 500-mg tablet contains 200–230 mg of dried extract, which contains 40 mg of isoflavones. Two randomized, placebo-controlled studies of the effect of Promensil on hot flushes were reported in 1999.<sup>839,840</sup> Neither demonstrated a significant difference compared with the placebo group. In one of the reports, 4 times the recommended dose (four tablets daily) also had no effect.<sup>840</sup> On the other hand, an appropriately designed Dutch study, two tablets daily, detected a significant reduction of flushing in a 12-week period of time.<sup>841</sup> A large placebo-controlled trial randomized 252 women with severe hot flushing to either Promensil (two tablets daily) or another red clover extract Rimostil (two tablets daily for an intake of 57 mg isoflavones).<sup>842</sup> The quantitative reduction in flushing (about 41% in 12 weeks) was identical in the Promensil, Rimostil, and placebo groups, although Promensil had a very slightly faster response. In another randomized clinical trial, the effect of red clover (a daily intake of 128 mg isoflavones) on vasomotor symptoms was no better than placebo treatment.<sup>843</sup> The best evidence indicates that the impact of red clover on vasomotor symptoms is the same as placebo treatment.



**Why do these randomized, blinded, and placebo-controlled trials lack agreement? One reasonable explanation is that isoflavones have a mild impact on hot flushing, detectable only in women with frequent and severe flushing. A major clinical response should not be expected. Another possibility is the role of equol (see later discussion).**

## **Don Quai, Ginseng, and Vitamin E**

One randomized, placebo-controlled trial examined the effect of dong quai on hot flushing.<sup>786</sup> No estrogenic effects could be detected on flushing, endometrium, or vagina; furthermore, it could have potential adverse effects including light sensitivity and increased bleeding risk in those taking warfarin.<sup>786</sup> Ginseng has the same impact on menopausal symptoms as placebo treatment.<sup>787</sup> Similarly, vitamin E supplementation is ineffective for VMS.<sup>785</sup>

## **Evening Primrose**

Evening primrose is often recommended for mastalgia, PMS, and menopausal symptoms. Evening primrose oil is extracted from the seed of the evening primrose; it provides linoleic and gamma-linoleic acids (precursors of prostaglandin E). Appropriately blinded and controlled studies have failed to find any differences comparing primrose oil with placebo.<sup>844,845,846</sup>

## **Black Cohosh**

Black cohosh (*Cimicifuga racemosa*) is also called black snakeroot and bugbane. It has been widely promoted to treat hot flashes. Unfortunately, most of the early reports supporting the efficacy of black cohosh were case series or studies without placebo control groups, or the studies did not directly and quantitatively measure hot flushing.

Overall, black cohosh has been reported to contain formononetin, a methylated precursor that is metabolized to the two primary phytoestrogens, genistein and daidzein. More sophisticated analysis, however, using liquid chromatography methods, has failed to detect the presence of formononetin in various black cohosh preparations, nor in black cohosh roots and rhizomes.<sup>847</sup>

An older clinical trial was noteworthy and alone in finding a similar impact on hot flushing with black cohosh and placebo treatment.<sup>788</sup> Well-designed trials are confirming that early study and providing us with a uniform story. The Herbal Alternatives for Menopause (HALT) Study is centered in Seattle, Washington. This double-blind trial randomized 351 women to placebo or one of the four treatment groups: (1) black cohosh 160 mg daily (note the higher dose); (2) a multibotanical

treatment containing 50-mg black cohosh, alfalfa, chaste tree, dong quai, false unicorn, licorice, oats, pomegranate, and Siberian ginseng, four capsules daily; (3) the multibotanical plus counseling to increase dietary soy intake; and (4) conjugated estrogens 0.625 mg with or without 2.5 mg medroxyprogesterone acetate.<sup>848</sup> After 1 year, no differences were observed in hot flushing comparing any of the three herbal treatment groups to placebo.<sup>848</sup> The herbal remedies also had no effect on sleep quality as reported after 3 months.<sup>849</sup>

A randomized trial in Chicago compared black cohosh, 128 mg, and red clover, 120 mg, to standard hormone therapy and placebo treatment.<sup>843</sup> Over a period of 1 year, only hormone therapy reduced vasomotor symptoms greater than placebo. In this same clinical trial, neither black cohosh nor red clover had an impact on measures of cognition.<sup>850</sup> A Mayo Clinic study reported the results of a double-blind, randomized, crossover clinical trial to assess the efficacy of black cohosh for the treatment of menopausal hot flashes.<sup>792</sup> The dose was 20 mg b.i.d., the dose of the most commonly marketed black cohosh product in the United States. The similarity of the studied product with Remifemin was confirmed by high-performance liquid chromatography and proton nuclear magnetic resonance analysis. One hundred and thirty-two patients were treated for two 4-week crossover periods. Black cohosh reduced hot flushing scores by 20% in the fourth treatment week compared with 27% in the placebo group, and frequency was reduced 17% on black cohosh and 26% on placebo. A randomized trial in Australia found no difference between placebo and a combination of black cohosh with Chinese herbs.<sup>851</sup>

**Black cohosh is not estrogenic, and black cohosh has no effect on menopausal symptoms.**

An expert committee of the U.S. Pharmacopoeia concluded that black cohosh may be associated with hepatotoxicity; however, a European review of cases with hepatotoxicity emphasized the difficulty in establishing a cause-effect relationship.<sup>852,853</sup> Hepatotoxicity remains a concern, awaiting the accumulation of definitive data.

# Ginkgo Biloba

Ginkgo biloba is an extract prepared from the leaves of the G. biloba tree. It contains flavonoids and unique terpene lactones. Ginkgo biloba is a multimillion-dollar herb sold in the United States for the preservation of memory. In vitro studies suggested that ginkgo had antioxidant (from the flavonoids) and antiamyloid (from the lactones) effects. Indeed, the biologic studies provided a rationale for the use of ginkgo to prevent dementia.

A randomized, double-blind, placebo-controlled trial comparing Ginkgo biloba with placebo for the prevention of dementia enrolled 3,069 elderly individuals (over age 75) in five academic centers in the United States.<sup>854,855</sup> The participants were randomized to b.i.d. doses of 120-mg ginkgo or placebo (45% female in the ginkgo group and 47% female in the placebo group). The ginkgo formulation and dosage were that used in many of the brands sold in the United States. The dementia rate steadily increased in both groups over a 7-year period of follow-up, accumulating 277 cases (17.9%) in the treatment group and 246 cases (16.1%) in the placebo group. The rate of dementia did not differ between the two groups, nor did the rate of Alzheimer disease. In addition, treatment with Ginkgo biloba did not produce less cognitive decline in either adults with normal cognition or with mild cognitive impairment. Other randomized trials have failed to demonstrate any beneficial effects on Alzheimer's, learning, memory, attention, verbal fluency, or concentration.<sup>856,857</sup> Caution is warranted however when considering treatment in those with cardiovascular disease as it may be proarrhythmic; further studies in those with cardiac disease are needed.<sup>858</sup>

**The American trial robustly demonstrated that Ginkgo biloba in the tested and commonly used dose did not delay the onset of dementia or cognitive decline.**<sup>854,855</sup> The concept of “delay” is important. A treatment that could delay the onset of dementia by 5 years would reduce the number of dementia cases by 50%. In fact, this clinical trial found a statistically significant increase in the risk for developing dementia with ginkgo treatment in the 25% of participants who had cardiovascular disease prior to enrollment. However, the authors appropriately urged caution in interpreting this subgroup analysis. **A Cochrane review in 2007 of 35 clinical trials with 4,247 participants concluded that there was no convincing evidence that ginkgo treatment benefited individuals who already had dementia or cognitive impairment.**<sup>859</sup>

# St. John's Wort

St. John's wort has been reported to be comparable to tricyclic antidepressants in treating mild to moderate depression, based on eight appropriate trials.<sup>860</sup> This is the conclusion of two meta-analyses.<sup>861,862</sup> All studies were short term, about 4–6 weeks in duration, and with small numbers. The treatment consisted of a 300-mg plant extract in tablet form, administered t.i.d. However, two large, American 8-week trials found no difference between treatment and placebo.<sup>863,864</sup>

The U.S. Food and Drug Administration (FDA) issued an alert in February 2000 that St. John's wort may interact with drugs known to be metabolized by the cytochrome P450 pathway: theophylline, digoxin, immune suppressants, and oral contraceptives.<sup>865,866</sup> St. John's wort activates an orphan receptor that induces the expression of metabolic enzymes.<sup>867</sup> In clinically depressed individuals being treated with prescription antidepressants, manic reactions can result (the central serotonergic syndrome).

# Phytoestrogens and Cardiovascular Disease

The cardiovascular story with phytoestrogens received a large boost in 1995, when a meta-analysis concluded that an intake of an average of 47 g soy protein/day lowered total cholesterol and LDL cholesterol.<sup>868</sup> This was supported by studies in the monkey indicating that isoflavone increased HDL cholesterol, enhanced vasodilation, and decreased atherosclerosis.<sup>869</sup>

Only intact soy protein has a beneficial effect on lipids. Separation of the protein component from dietary soy protein loses the effect. This effect depends on the inhibition of cholesterol absorption by the nonisoflavone protein.<sup>870,871</sup> The mechanism involves up-regulation of the LDL cholesterol receptor and catabolism of LDL cholesterol, leading to an increase in bile excretion. The soy peptide binds bile acids and prevents resorption. Alcohol extraction removes the isoflavones from soy protein and causes a loss of the beneficial effect on atherosclerosis in monkeys.<sup>872</sup> Thus, both the isoflavone portion and the protein component are required for a full cardiovascular effect. Non-alcohol-washed soy protein extract has been extensively studied in monkeys. This preparation lowers total cholesterol and LDL cholesterol and raises HDL cholesterol,<sup>873,874</sup> produces coronary artery vasodilation,<sup>875</sup> inhibits reduction in coronary flow after collagen induced platelet aggregation and serotonin release,<sup>876</sup> and inhibits atherosclerosis but not as robustly as estrogen.<sup>869,874</sup>

In women, soy protein reduces total and LDL cholesterol and does not affect triglycerides or HDL cholesterol; ethanol-extracted soy protein has no effect.<sup>877,878,879,880</sup> The minimal dose is about 60 mg isoflavones daily, which is present in 25 g soy protein/day.<sup>881</sup> LDL cholesterol must be above 130 mg/dL in order to have an effect. Studies of healthy men and women could detect no effect of phytoestrogens (25–80 mg isoflavones per day) on lipids or brachial vasodilation.<sup>882,883,884</sup> In a 12-week study of women with type 2 diabetes mellitus, dietary supplementation of 30 g soy protein (132 mg isoflavones) daily improved insulin resistance and glucose control in addition to lowering total cholesterol and LDL cholesterol levels.<sup>885</sup> In addition, soy intake prevents LDL cholesterol oxidation in hyperlipidemic men and women even when circulating LDL cholesterol levels are unaffected.<sup>886</sup> Promensil, in a 10-week study, had no effect on lipids (it only contains isoflavones, no protein) but did improve arterial compliance.<sup>887</sup>

The U.S. FDA, in October 1999, authorized the use in food labeling of health claims related to the association between soy protein and reduced risk of CHD, “based on the totality of publicly available scientific evidence, soy protein included in a diet low in saturated fat and cholesterol may reduce the risk of CHD by lowering blood cholesterol

levels.”<sup>888</sup>

Remember that both protein and isoflavones are needed for a cardiovascular effect. Isoflavones by themselves have no effect on lipids.<sup>887,889,890</sup> Protein without isoflavones has no effect on vasodilation and atherosclerosis.<sup>872</sup> The FDA has stated that there is insufficient evidence to allow them to exclude alcohol-washed products from the health claim, but it makes sense that a combined protein-isoflavone product is best. Even in older women with moderate hypercholesterolemia, a high intake of soy phytoestrogens (purified isoflavones without protein) had no effect on the lipid profile.<sup>891</sup> And also remember that there is no effect on the lipids in individuals who already have a normal profile. Even in individuals with high cholesterol levels, the beneficial impact of soy protein intake is modest and likely to have little clinical effect.

It will require appropriate clinical trials to determine how phytoestrogens compare in the cardiovascular system with estrogens and to determine the efficacy, safety, and correct dosage (studies thus far recommend a daily intake of 60 g soy protein). In addition, the intake of sufficient soy to produce a clinical response is not easy; intake is handicapped by gastrointestinal symptoms, a major alteration in diet or the use of an unpalatable supplement, and great variability in plant contents and products (due to processing). A dietary intake to match the isoflavone dose used in the studies on the lipid profile, for example, would require about 1 lb daily of tofu! In addition, individuals demonstrate great variability in absorption and metabolism. A user-friendly preparation must be developed that minimizes individual variability in response. **Despite the abovementioned observations, there is no clinical evidence that supports a preventative role for soy intake against cardiovascular disease.**

# Phytoestrogens and Cognition

Phytoestrogens up-regulate cognition markers and improve memory in rats equally when compared with estrogen.<sup>892,893</sup> Soy supplementation has been suggested to improve measurements of memory and attention in postmenopausal women.<sup>894,895</sup> On the other hand, randomized trials detected no effects of soy protein, red clover, or black cohosh on tests of memory, executive function, language, visual perception, cognition, or measures of quality of life.<sup>850,884,896,897</sup> On the contrary, there is one human study involving men that is disturbing. In a National Institutes of Health study that began in 1965, men reported their tofu consumption.<sup>898</sup> Cognition was tested in 1991–1993 between the ages 71 and 93. Higher midlife tofu consumption (two or more servings per week) was associated with poor cognitive test performance, enlargement of ventricles, and low brain weight.

**At the present time, there is no role for phytoestrogens for cognitive benefit.**

# Phytoestrogens and the Breast

In the parts of the world where soy intake is high, there is a lower incidence of breast, endometrial, and prostate cancers.<sup>899</sup> For example, a case-control study concluded that there was a 54% reduced risk of endometrial cancer, and another case-control study indicated a reduction in the risk of breast cancer in women with a high consumption of soy and other legumes.<sup>900,901</sup> Daidzein and genistein urinary excretion is lower in Australian women who develop breast cancer.<sup>902</sup> High soy and tofu consumption, and high urinary excretion of isoflavones have been reported to be associated with a lower risk of breast cancer in Singapore, China, and Australia. There is even a lowered risk of breast cancer in American women consuming a diet rich in isoflavones.<sup>901,903,904,905,906,907</sup> These studies have supported the belief that high phytoestrogen intake protects against breast cancer. It is by no means certain, however, that there is a direct effect of soy intake.<sup>908</sup> Indeed, a 6-month study of the impact of administered soy protein on breast secretions in premenopausal and postmenopausal women revealed increased breast secretions with the appearance of hyperplastic epithelial cells.<sup>909</sup> Epithelial hyperplasia based on cytology in breast secretions was demonstrated in 7 of 24 (29.2%) of the subjects. Swedish and English cohort studies could not detect a relationship between dietary phytoestrogens and the risk of breast cancer.<sup>910,911</sup>

Genistein increases epidermal growth factor in immature rat mammary tissue, and it has been hypothesized that earlier exposure to genistein promotes early cell differentiation leading to breast glands that are more resistant to the development of cancer.<sup>912</sup> On the other hand, using the chemically induced rat breast cancer model, no evidence of isoflavone inhibition on tumor development has been detected.<sup>913</sup> In the monkey, treated for 6 months, no proliferation was reported in either endometrium or mammary tissue.<sup>914,915</sup>

One hypothesis speculates that phytoestrogens protect the breast by decreasing exposure to the more potent endogenous estrogens. The evidence does not support this idea. High-dose treatment (100 mg of daidzein plus 100 mg genistein) does lower estradiol and DHEA-S levels in premenopausal women and increases cycle length.<sup>916</sup> However, these are extremely high doses. One study reported that treatment with Asian soy foods (approximately 32 mg isoflavones per day) was associated with a 9.3% significant decrease in luteal serum estradiol levels, but there were no other changes, including follicular phase estradiol, progesterone levels, and SHBG levels, or cycle length.<sup>917</sup> Interestingly, the reduction in luteal estradiol was observed only in Asian participants in whom urinary excretion of isoflavones was higher than non-Asians.<sup>917</sup> These same investigators reported that a high intake of the soy protein alone (with the



isoflavones removed) reduced estradiol and progesterone levels throughout the cycle.<sup>918</sup> Other studies have found no effects on estradiol, FSH, LH, or SHBG in premenopausal women<sup>919</sup> and, most importantly, no effects on circulating hormones in postmenopausal women.<sup>920,921</sup> The lack of an effect on gonadotropin and steroid levels is important, depriving the clinician of a method to assess dosage.

Catechol estrogens (2-hydroxy- and 4-hydroxyestrogens) have long been proposed as a metabolite pathway that could be protective or at least antiestrogenic. Hydroxylation in the 2 or 4 position produces inactive metabolites. In one study, eight premenopausal women treated with a soy milk supplement increased their urinary excretion of 2-hydroxyestrone by an average of 47%.<sup>922</sup> Another study could detect no change in 2-hydroxyestrogens.<sup>919</sup> A study limited to Asian American women also was unable to identify an impact of soy intake on overall estrogen metabolite excretion; however, an increase in catechol estrogens was observed with greater soy intake, balanced by a decrease in 16-hydroxylation.<sup>923</sup>

In response to soy, no significant increase in nipple aspirate levels of genistein and daidzein could be detected.<sup>924</sup> However, an indication of estrogenic stimulation occurred, as measured by pS2 (a protein up-regulated by estrogen) levels, but there was no evidence of an effect on epithelial cell proliferation, estrogen and progesterone receptors, apoptosis, or mitosis. Thus, no antiestrogenic effect could be detected, and at best, there was a very weak estrogen effect. In another study, 48 women with normal breasts received a 60 g soy supplement for 14 days, and in these women, lobular epithelial proliferation and progesterone receptor expression increased, an indication of estrogen stimulation.<sup>925</sup> Some argue that the key to a beneficial impact on the breast may be early exposure, and a sudden increase late in life of dietary phytoestrogens may be harmful. On the other hand, a Chinese cohort study of 5,042 breast cancer survivors documented a reduced risk of recurrence and death associated with increasing levels of soy intake, evident among women with either estrogen receptor–positive or receptor–negative disease and among either tamoxifen users or nonusers.<sup>926</sup> In an American cohort of 1,954 breast cancer survivors, a 60% greater decrease in breast cancer recurrence was observed in postmenopausal women using tamoxifen comparing the highest level of soy intake with the lowest.<sup>927</sup> **Most of the evidence indicates that a high intake of phytoestrogens is associated with a reduced risk of breast cancer, including recurrence in breast cancer survivors. It is not known whether this effect is a marker for beneficial metabolic responses to phytoestrogens or whether there is a direct impact on breast tissue. The evidence also indicates that phytoestrogen consumption does not adversely interfere with tamoxifen’s mechanism of action.**

There is agreement that phytoestrogens have no effects on the uterus or

vagina.<sup>786,839,840,889,920,921,928,929,930,931,932</sup> A beneficial effect on vaginal dryness and dyspareunia cannot be expected; however, the lack of a proliferative stimulus on the endometrium is a wanted consequence of phytoestrogen supplementation (Table 17.11).

## **TABLE 17.11 Summary of Phytoestrogen Clinical Effects**



Flushes	Insignificant effect
Coronary heart disease	Weak impact
Bone	No effect
Cognition	Unknown
Breast	May be protective
Endometrium	No effect
Vagina	No effect

**Currently, the recommended intake expected to have some effect on CHD is 50–60 mg isoflavones per day, an amount that is in 25 g of soy protein aqueous extract. A beneficial impact on CHD in women with abnormal lipid profiles is to be expected, a consequence of a decrease in total and LDL cholesterol and an increase in vascular reaction, but the actual clinical effect is unknown. Excess intake can cause gastrointestinal upset and flatulence, inhibition of enzymes necessary for the digestion of proteins, possibly obstruction of mineral uptake, and weight gain.**

# The Role of Equol

Equol is a bacterial metabolite and the only hormonally active metabolite of the soy phytoestrogen, daidzein. It is one of the estrogenic compounds in pregnant mare's urine, hence its name. At least in vitro, equol stimulates gene transcription with both estrogen receptors and with a greater potency than any other isoflavone.<sup>933</sup> Equol formation is totally dependent on intestinal microflora; therefore, strictly speaking, it is not a phytoestrogen. To be accurate, equol is a nonsteroidal estrogen, a member of the isoflavone family, and exclusively a metabolic product of intestinal bacteria.

The most important observation regarding equol is that 30–50% of adults do not produce equol, even when challenged with high doses of soy.<sup>934</sup> This is in contrast to nonhuman primates and other animals; all that have been studied produce high levels of equol. Thus, there are two human populations: equol producers and equol nonproducers. The key question is whether equol producers receive greater clinical effects from phytoestrogens than nonequol producers. As noted, thus far, the clinical effects of isoflavones on the bone have not been impressive. In a 2-year randomized trial of postmenopausal women, isoflavone-rich soy milk increased spinal bone mass in the 45% of the subjects who were equol producers, with essentially no effect in equol nonproducers.<sup>935</sup> More profound beneficial effects on the lipid profile have been reported in equol-producing women.<sup>934</sup> Therefore, the population destined to receive a benefit from soy intake may be limited to equol producers. Studies need to be repeated measuring the responses in individuals who are identified as equol producers or equol nonproducers. If the population destined to receive a benefit from soy intake is limited to equol producers, a convenient, inexpensive method must be developed to identify equol production. It may be possible to convert nonproducers to producers.

An emerging approach is to administer equol itself. Daidzein yields two forms of equol, the R-equol inactive isomer and S-equol, the active isomer that binds to estrogen receptor- $\beta$ . S-equol has been synthesized and its administration is effective for the treatment of menopausal symptoms.<sup>936</sup> Another alternative is the S-equol supplement made by incubating equol-producing bacteria with soy isoflavones.<sup>937,938</sup> S-equol also blocks the activity of dihydrotestosterone, and thus, it has potential to treat androgenic effects such as acne, hirsutism, male pattern baldness, and prostate cancer.<sup>939</sup>

# Estriol

Interest in estriol can be traced to Lemon's report in 1975 that estriol limited the growth of breast tumors in the chemical-induced rat tumor model. However, it is usually overlooked that estradiol worked equally well in that model. Estriol treatment of postmenopausal women has no overall effect on lipids and no effect in the prevention of myocardial infarction.<sup>940,941</sup> Estriol, without concomitant progestin treatment, does increase the risk of endometrial cancer with the long-term oral use of 1–2 mg/day.<sup>829</sup> At least two studies have been unable to demonstrate prevention of bone loss with the administration of 2 mg estriol daily.<sup>486,487</sup> And one case-control study found no reduction in hip fractures with estriol compared with a lower risk with estradiol.<sup>941</sup> There is no evidence indicating any beneficial effects unique to estriol.

# Transdermal Progesterone

Transdermal (or percutaneous) compounded progesterone cream has been erroneously promoted to have multiple benefits. In order to achieve widespread effects, absorption must yield adequate blood levels. Two English randomized, blinded, placebo-controlled studies used 2 to 4 times the recommended dose and reported blood levels of about 1 ng/mL, supported by very low urinary pregnanediol levels.<sup>942,943</sup> An American study achieved progesterone blood levels of 2–3 ng/mL with application twice daily.<sup>944</sup> An Italian 1-year study did not measure blood levels but could detect no effects on bone density, lipid profiles, or depression scores.<sup>945</sup>

These studies indicate very little systemic absorption of progesterone from the cream product (the levels do not reach normal luteal phase concentrations), and there is great variability.

An English randomized clinical trial using transdermal doses of 5, 20, 40, and 60 mg progesterone cream could detect no differences in measures of psychological, somatic, and vasomotor symptoms compared with placebo.<sup>946</sup> An Australian study of 16, 32, or 64 mg transdermal progesterone cream administered daily could detect no significant absorption and, most importantly, no endometrial response and no effect on flushes, lipids, bone, moods, or sexuality.<sup>947,948</sup> Incidentally, this study found salivary progesterone levels to be so variable that they had no meaning. Progesterone cream can produce high salivary levels, without a significant change in serum or urinary levels (the mechanism is unknown).<sup>949,950</sup> Red cell levels reflect serum levels and do not indicate preferential transport or sequestration.<sup>950</sup> Wild yam creams are marketed as progesterone precursors or “balancing” formulas. Yam contains diosgenin, a plant steroid that can be converted to progesterone in a chemical laboratory but not in the human body. Predictably, a wild yam cream has no effects on a wide range of measurements in postmenopausal women.<sup>930</sup> Some do contain progesterone, added by the manufacturer. Creams with less than 0.016% progesterone can be sold over the counter. There is no evidence to indicate that these preparations produce systemic effects.

Better absorption is provided by progesterone gels, an alcoholic solution with hydroxypropyl methylcellulose and water.<sup>931</sup> With a 100-mg dose of a progesterone gel, serum progesterone levels are well into the luteal phase range, but clinical use awaits studies documenting the impact on the endometrium.<sup>951</sup>

**Clinicians and patients should be aware that transdermal progesterone cream will not reduce hot flashes more than a placebo response, but most importantly, this treatment will not protect the endometrium against the risk of endometrial cancer**

**associated with estrogen therapy.**

Lastly, for women with VSMs, additional nonpharmacologic options include environmental and lifestyle changes. Remaining in a cool environment and weight loss have been shown to decrease the number of hot flashes. Complementary and alternative medicine can also be attempted; however, treatments with dong quai, ginseng, black cohosh, isoflavones (including soy protein), yoga, and acupuncture with placebo treatment.<sup>786,787,788,789,790,791,792,793,794,795,796</sup>

## Key points: Vasomotor Symptom Management

- HT remains the most effective of available therapeutic options for managing VMS.
- In patients in whom HT is contraindicated, non-hormonal pharmaceuticals can be effective against VMS.
- Patients and providers should be reassured regarding availability of effective standardized and approved bioidentical HT formulations.
- Utilization by patients of non-standardized, unapproved compounded formulations that are being advertised direct to consumers is to be discouraged due to concerns regarding safety as well as effectiveness of such products.
- Benefit of alternative therapies is at best minimal, if any.

# MANAGING BLEEDING DURING MENOPAUSAL HORMONE THERAPY

---

With sequential therapy, approximately 80–90% of women experience monthly withdrawal bleeding. With continuous, combined estrogen-progestin therapy, one can expect 40–60% of patients to experience breakthrough bleeding during the first 6 months of treatment; however, this percentage decreases to 10–20% after 1 year.<sup>568,569,952</sup> Although this percentage of amenorrhea with continuous, combined therapy is a gratifying accomplishment, the number of women who experience breakthrough bleeding is considerable, and it is a difficult management problem. Indeed, the single most aggravating and worrisome problem with daily, continuous therapy is this breakthrough bleeding.

Why call it breakthrough bleeding? The bleeding experienced by women on continuous, combined therapy is similar to that seen with oral contraceptives. It originates from an endometrium dominated by progestational influence; hence, the endometrium is usually atrophic and yields little, if anything, to the exploring biopsy instrument. Breakthrough bleeding is due to a progestational effect on vascular strength and integrity, producing a fragility that is prone to breakdown and bleeding. It is helpful to explain to patients that this bleeding represents tissue breakdown as the endometrium adjusts to its new hormonal stimulation. From our experience with oral contraceptives, we have learned to be comfortable with this type of bleeding. We have learned that for most patients, the incidence of breakthrough bleeding with oral contraceptives is greatest in the first few months of treatment and usually disappears in the majority of women. Indeed, this is the same pattern exhibited by postmenopausal women on continuous, combined therapy, and, therefore, the most effective management strategy is patient education and support.

It is common for women on a sequential regimen to begin bleeding while in the midst of progestin administration. The timing of withdrawal bleeding in women on a sequential estrogen-progestin program was suggested as a screening method for biopsy decision-making. In women taking a variety of progestins for 12 days each month, bleeding on or before day 10 after the addition of the progestin was associated with proliferative endometrium. Bleeding beginning on day 11 or later was associated with secretory endometrium, presumably indicating less need for biopsy.<sup>953</sup> But does this correlate with the risk of hyperplasia and cancer? According to a study of 413 postmenopausal women, the day of bleeding did not predict endometrial safety.<sup>954</sup> Late regular withdrawal bleeding on a sequential program does not give 100% assurance that there is no hyperplasia and perhaps endometrial cancer. This uncertainty with the sequential program is another reason to turn to the daily, combined method where



irregular bleeding and sonographic measurement of increased endometrial thickness provide good indications for endometrial biopsy.

Evaluation of abnormal uterine bleeding in the setting of hormone use is identical to the paradigm discussed earlier in this chapter. The thickness of the postmenopausal endometrium as measured by TVUS in postmenopausal women correlates with the presence or absence of pathology. However, the severity of pathologic change does not correlate with the measured thickness.<sup>955</sup> Endometrial thickness (the two layers of the anterior and posterior walls in the longitudinal axis) equal to or less than 4 mm is highly<sup>956</sup> reassuring (negative predictive value is >99%), supported by the American College of Obstetricians and Gynecologists, and allows conservative management.<sup>957,958,959,960,961</sup>

It is estimated that 50–75% of patients experiencing abnormal uterine bleeding on hormone therapy and evaluated by TVUS will eventually require a biopsy.<sup>955,962</sup> It seems logical that endometrial thickness by TVUS in patients on a sequential regimen can be affected by day in the treatment cycle, and for that reason, ultrasonography assessment should be obtained toward the end of the progestin phase or at the beginning of the cycle.<sup>963,964</sup> An Italian study concluded that endometrial thickness measured soon after withdrawal bleeding in women on a sequential regimen was comparable to thickness in women on a continuous, combined program of estrogen-progestin treatment.<sup>965</sup> When a thick endometrium is associated with atrophic endometrium on biopsy, polyps or submucous myomas should be suspected. A thorough curettage can miss such pathology, and either a SHG or hysteroscopy should be considered as the next step as discussed earlier.<sup>181</sup> Doppler velocimetry does not improve the accuracy of discriminating between normal and abnormal endometrium.<sup>966</sup> **A clinician should not be satisfied with “normal” findings on ultrasonography if a patient has persistent bleeding. The pursuit of abnormal bleeding despite “normal” findings should reduce missed cases of pathology to nearly zero.**<sup>967</sup> **In this circumstance, hysteroscopy is recommended.**

There is no effective method supported by clinical studies, or a large experience, of drug alteration or substitution to manage breakthrough bleeding. The breakthrough bleeding rate is only slightly better with a higher dose of progestin (5.0 mg medroxyprogesterone acetate) than with a lower dose (2.5 mg).<sup>568,952</sup> Therefore, there is not a strong reason to use the higher dose, thus minimizing side effects. The best approach is to gain time, because most patients will cease bleeding. This means good educational preparation of the patient beforehand and frequent contact to allay anxiety and encourage persistence. Estrogen-progestin combinations that contain a 19-nortestosterone progestin (e.g., norethindrone acetate) demonstrate the same pattern of

bleeding, but fewer patients bleed in the first 6 months and the amenorrhea rate by 1 year is higher than with other regimens.<sup>968,969,970</sup>

There is a subgroup of patients (10–20% at the end of 1 year) who continue to experience breakthrough bleeding. The closer a patient is to having been bleeding (either to her premenopausal state or to having been on a sequential method with withdrawal bleeding), the more likely that patient will experience breakthrough bleeding. Some clinicians, therefore, prefer to start patients near the menopause on the sequential method and convert to the continuous method some years later. Some patients may choose to undergo a progestin IUD as a menopausal hormone therapy strategy, discussed in detail in [Chapter 23](#). The local release of progestin is effective in suppressing endometrial response and preventing unscheduled bleeding in the long term. The LNG-IUD in menopausal women can be left in place for up to 10 years, a decided advantage.<sup>603,971</sup> **A combined estrogen-progestin program however, will not totally prevent endometrial cancer.<sup>972</sup> Vigilance on the part of the clinician, however, will detect endometrial cancer at an early stage, a stage that can be treated with excellent results.**

For the smaller subset of hormone-using menopausal women who are bothered by persistent unscheduled bleeding that remains unresponsive to above strategies, consideration for definitive surgery (such as vaginal hysterectomy) may not be unreasonable.

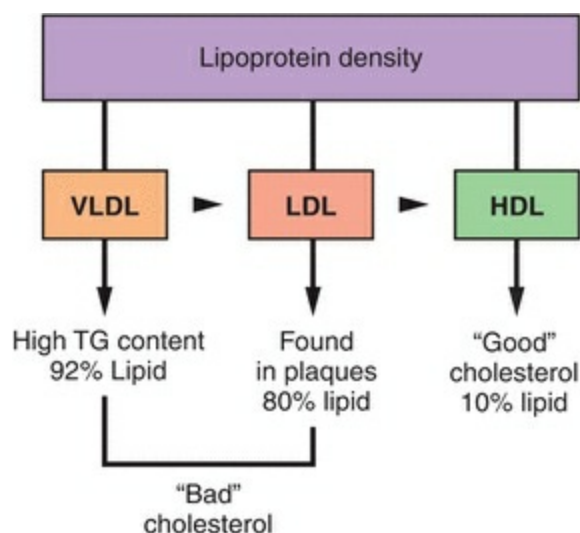
# HEALTH IMPLICATIONS OF MENOPAUSAL HORMONE THERAPY

---

# Cardiovascular Effects

## A Favorable Impact on Lipids and Lipoproteins

The most important lipid effects of postmenopausal estrogen treatment are the reduction in LDL cholesterol and the increase in HDL cholesterol. Estrogen increases triglyceride levels and LDL cholesterol catabolism as well as lipoprotein receptor numbers and activity, resulting in decreasing LDL cholesterol levels.<sup>973,974,975</sup> Estrogen induces a change in LDL cholesterol toward a smaller more dense particle, but it is in a form with a more rapid turnover in the circulation, allowing less time for oxidation and acquisition of cholesterol.<sup>976,977</sup> The increase in HDL cholesterol levels, particularly due to the HDL<sub>2</sub> subfraction, is to an important degree the consequence of the inhibition of hepatic lipase activity, which converts HDL<sub>2</sub> to HDL<sub>3</sub> (Figure 17.14). Postmenopausal estrogen therapy with or without added progestin also produces a reduction in the circulating levels of lipoprotein(a).<sup>424,978</sup>



**FIGURE 17.14**

The changes in circulating apoprotein levels mirror those of the lipoproteins: apolipoprotein B (the principal surface protein of LDL cholesterol) levels diminish in response to estrogen, and apolipoprotein A-I (the principal apolipoprotein of HDL cholesterol) increases. The positive effects of estrogens on cholesterol may be mitigated by the concomitant use of progestins.<sup>569,571,979,980,981,982,983,984</sup> The concomitant administration of estrogen and an HMG-CoA reductase inhibitor (such as pravastatin) produced a more favorable change in the lipid profile in hypercholesterolemic women

than either treatment alone.<sup>985</sup>

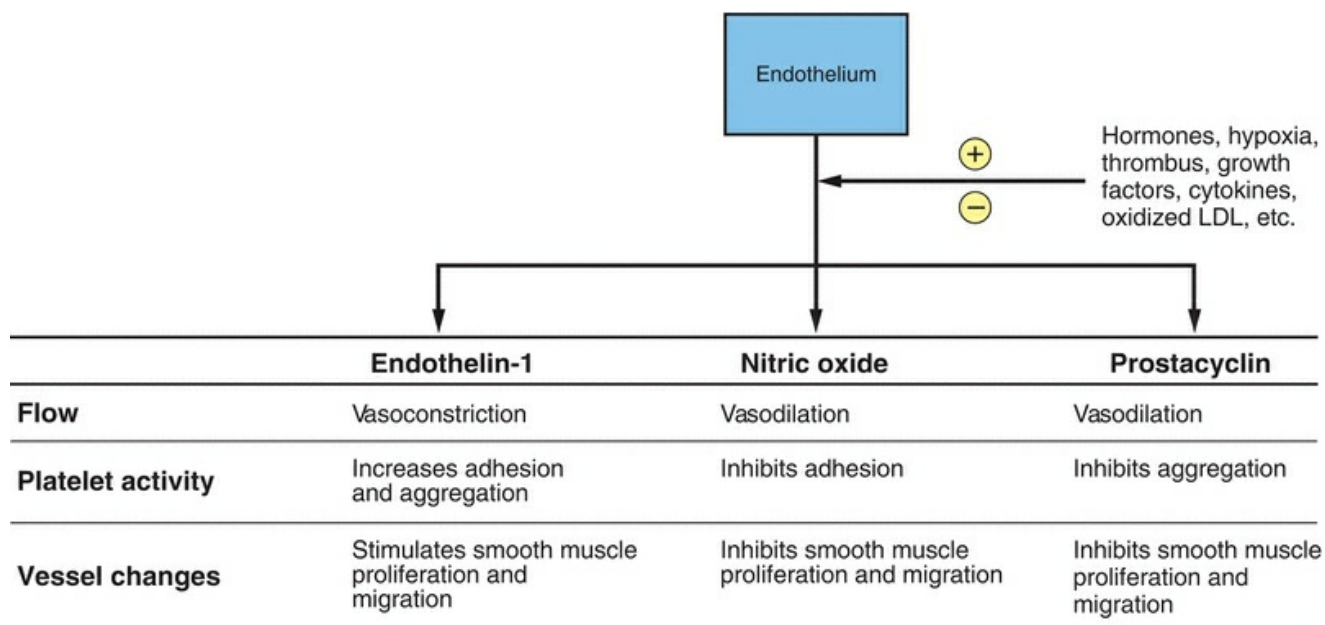
## Direct Antiatherosclerotic Effects

Studies in nonhuman primates (such as monkeys) have suggested that estrogen may have antiatherosclerotic effects that are independent of the cholesterol-lipoprotein profile. Oral administration of a combination of estrogen and a high dose of progestin to monkeys fed a high-cholesterol diet decreased the extent of coronary atherosclerosis despite a reduction in HDL cholesterol levels.<sup>986,987,988</sup> In somewhat similar experiments, estrogen treatment markedly prevented arterial lesion development in rabbits, and this effect was not reduced by adding progestin to the treatment regimen.<sup>989,990,991,992</sup>

The monkey studies were extended to a postmenopausal model (ovariectomized monkeys). Compared with no hormone treatment, treatment with either estrogen alone or estrogen with progesterone in a sequential manner significantly reduced atherosclerosis, once again independently of the circulating lipid and lipoprotein profile.<sup>993,994</sup> A direct inhibition of LDL cholesterol accumulation and an increase in LDL cholesterol metabolism in arterial vessels could be demonstrated in these monkeys being fed a highly atherogenic diet.<sup>995</sup> The daily administration of medroxyprogesterone acetate in this monkey model did not prevent the beneficial effect of CEE on coronary artery atherosclerosis.<sup>869</sup>

Estradiol fatty acid esters are present in low concentrations in the circulation, transported in lipoproteins. These esters are potent estrogens and protect against the oxidation of LDL cholesterol; the antioxidant efficacy of estradiol may require esterification and incorporation into LDL cholesterol.<sup>996</sup> Estradiol fatty acid ester concentrations are increased by oral estrogen but not by transdermal administration.<sup>997</sup>

## Endothelium-Dependent Vasodilation and Antiplatelet Aggregation (see [Figure 17.15](#))



**FIGURE 17.15**

Endothelium modulates the degree of contraction and function of the surrounding smooth muscle, primarily by the release of endothelium-derived relaxing and contracting factors. In hypertension and other cardiovascular diseases, the release of relaxing factors (such as nitric oxide) is blunted, and the release of contracting factors (the most important being endothelin-1) is augmented. The endothelins are a family of peptides that act in a paracrine fashion on smooth muscle cells. Endothelin-1 appears to be exclusively synthesized by endothelial cells. Endothelin-induced vasoconstriction is a consequence of a direct action on vascular smooth muscle cells, an action that is reversed by nitric oxide. Impaired release of nitric oxide, therefore, enhances endothelin action. Hypertension and atherosclerosis are believed to be influenced by the balance among these factors. Women have lower circulating levels of endothelin, which decrease in response to oral and transdermal estrogen treatment.<sup>998,999</sup>

Nitric oxide (and estrogen) also inhibits the adhesion and aggregation of platelets in a synergistic manner with prostacyclin (also a potent vasodilator derived from the endothelium).<sup>1000,1001</sup> Increased blood flow due to vasodilation and decreased peripheral resistance can be observed to occur rapidly following the administration of estrogen. This response can be produced by both transdermal and oral administration.<sup>1002,1003,1004</sup> The synthesis and secretion of nitric oxide (the potent endothelial vasodilating product) can be directly stimulated by estrogen in in vitro experimental preparations of coronary arteries.<sup>1005</sup> In both normotensive postmenopausal women and women with hypertension, hypercholesterolemia, diabetes mellitus, or coronary artery disease, the intra-arterial infusion of physiologic amounts of

estradiol into the forearm potentiates endothelium-dependent vasodilation, and there is a dose-response effect.<sup>1006,1007</sup> Similarly, brachial artery dilation has been reported with 0.3 and 0.625 mg conjugated estrogens.<sup>1008</sup> Comparing brachial artery responses in hormone therapy users versus nonusers (estrogens with/without progestin), improved endothelium-dependent vasodilation was observed with standard doses.<sup>1009</sup> Furthermore, the addition of norethindrone acetate or medroxyprogesterone acetate did not reduce the beneficial effect of estrogen on peripheral artery blood flow.<sup>1010,1011</sup> However, not all studies agree. A Danish assessment of brachial artery responses demonstrated no difference between postmenopausal women on long-term combined estrogen-progestin therapy compared with those receiving no treatment.<sup>1012</sup>

The synthesis of nitric oxide is involved in the regulation of vascular (and gastrointestinal) tone and in neuronal activity. A family of isozymes (nitric oxide synthases) catalyzes the oxidation of L-arginine to nitric oxide and citrulline. The action of nitric oxide synthase in the endothelium is calcium dependent.<sup>1013</sup> In animal experiments, the endothelial basal release of nitric oxide is greater in females, a gender difference that is mediated by estrogen.<sup>1005,1014</sup> In women treated with postmenopausal estrogen and either cyproterone acetate or medroxyprogesterone acetate, circulating nitric oxide (as reflected in nitrite-nitrate levels) is increased, a consequence of estrogen-induced nitric oxide production in the endothelium.<sup>1015,1016</sup> In contrast, long-term treatment with estradiol and norethindrone acetate was not associated with changes in nitric oxide, endothelin-1, prostacyclin, or thromboxane A<sub>2</sub>, suggesting that different progestins have differential effects.<sup>1017</sup>

Acetylcholine induces vasoconstriction in coronary arteries; however, the direct administration of estradiol in physiologic doses into the coronary arteries of postmenopausal women with and without CHD converts acetylcholine-induced vasoconstriction into vasodilation with increased flow.<sup>1018</sup> This favorable vasomotor response to acetylcholine can also be demonstrated in acute experiments with transdermal administration of estradiol (achieving blood levels of 67–89 pg/mL).<sup>1019</sup> This is an endothelium-dependent response, mediated to a significant degree by an increase in nitric oxide.<sup>1020</sup> In the monkey, the vasodilatory response to acetylcholine required a blood level of estradiol higher than 60 pg/mL.<sup>1021</sup>

## **Endothelium-Independent Vasodilation**

Estrogen causes relaxation in coronary arteries that are denuded of endothelium.<sup>1022</sup> This response is not prevented by the presence of inhibitors of nitric oxide synthase or prostaglandin synthase, thus suggesting that some degree of vasodilation in response to estrogen is achieved through a mechanism that is independent of the vascular

endothelium, perhaps acting via calcium-mediated events.<sup>1023</sup> The vasodilation produced by sodium nitroprusside is endothelium-independent. In otherwise healthy postmenopausal women and in those with risk factors for atherosclerosis (hypertension, hypercholesterolemia, diabetes mellitus, coronary artery disease), administration of physiologic doses of estradiol increased forearm vasodilation induced by sodium nitroprusside.<sup>1006</sup> However, others have reported no effect of estrogen administration on endothelium-independent vasodilation.<sup>1004</sup>

## **Actions on the Heart and Large Blood Vessels**

Estrogen treatment in some studies was associated with increased left ventricular diastolic filling and stroke volume,<sup>1004,1024,1025,1026</sup> an effect that probably reflects a direct inotropic action of estrogen.<sup>1027</sup> In a 3-month study, medroxyprogesterone acetate (5 mg daily for 10 days each month) did not attenuate the increase in left ventricular output (systolic flow velocity) observed with estrogen treatment.<sup>1028</sup> On the other hand, others have detected attenuation of estrogen's beneficial effects on compliance (stiffness) associated with combined estrogen-progestin treatment.<sup>1027,1029</sup> And others have not been able to demonstrate an effect of short-term oral estrogen or long-term transdermal estrogen treatment on cardiac structure and function.<sup>1030,1031</sup> The reasons for these observations as well as the differences remain unclear.

## **Actions on Glucose Metabolism**

An age-related decline in the basal metabolic rate is accentuated at menopause, associated with an increase in body fat, especially central (android) body fat.<sup>1032,1033</sup> Insulin resistance and circulating insulin levels increase in women after menopause, and impaired glucose tolerance predicts an increased risk of CHD.<sup>1034,1035</sup> Estrogen (with or without progestin) prevents the tendency to increase central body fat with aging.<sup>1036,1037,1038,1039</sup> The WHI randomized clinical trial documented improvements in fasting glucose and insulin levels in the estrogen-progestin-treated group.<sup>1040</sup> Hyperinsulinemia also has a direct atherogenic effect on blood vessels, perhaps secondary to insulin propeptides. In addition to its vasoconstrictive properties, endothelin-1 exerts a mitogenic effect and, therefore, contributes to the atherosclerotic process. Insulin directly stimulates the secretion of endothelin-1 in endothelial cells, and the circulating levels of endothelin-1 are correlated with insulin levels.<sup>1041</sup>

Postmenopausal women being treated with oral estrogen have lower fasting insulin levels and a lesser insulin response to glucose.<sup>981,1040,1042,1043,1044,1045</sup> In a 1-year randomized trial comparing unopposed conjugated estrogens to the usual sequential and



continuous regimens of conjugated estrogens and medroxyprogesterone acetate, no differences in the treatment groups were observed in the favorable decreases in fasting insulin levels.<sup>981</sup> Nonoral administration of estrogen has little effect on insulin metabolism, unless a dose is administered that is equivalent to 1.25 mg conjugated estrogens.<sup>1043,1046</sup> Because a lower oral dose produces a beneficial impact, this suggests that the hepatic first-pass effect is important in this response, at least in normal women; reports with transdermal hormone therapy have indicated improvements in insulin resistance and hyperinsulinemia, but no effect in women with normal insulin sensitivity.<sup>1047,1048</sup> In double-blind, crossover, placebo-controlled studies of postmenopausal women with type 2, non-insulin-dependent diabetes mellitus, estrogen treatment improved all glucose metabolic parameters (including insulin resistance), the lipoprotein profile, and measurements of androgenicity.<sup>1049,1050</sup>

**The evidence strongly indicates that postmenopausal estrogen therapy improves glucose metabolism. Epidemiologic studies impressively document that this beneficial metabolic effect associated with estrogen lowers the incidence of adult-onset, type 2 diabetes mellitus.** Three large cohort studies, the Nurses' Health Study, the Finnish Kuopio Osteoporosis Risk Factor and Prevention Study, and the French E3N study, reported decreases in new-onset diabetes associated with estrogen therapy.<sup>1051,1052,1053</sup> In the French cohort, no effect of progestins was observed, and the reduction in the incidence of diabetes (32%) was greater with oral administration of estrogen compared with the transdermal method.<sup>1053</sup> Clinical trial results are in agreement. In the HERS trial, the hormone-treated group developed diabetes at a rate that was 35% lower compared with the placebo group.<sup>1045</sup> Similar findings were observed in the Women's Health Initiative Hormone Trials wherein a 21% reduction in incident diabetes was observed in the combined E and P trial, whereas a 12% reduction with the estrogen-alone trial.<sup>534,1054</sup>

## **Inhibition of Lipoprotein Oxidation**

The oxidation of LDL cholesterol particles is a step (perhaps the initial step) in the formation of atherosclerosis, and smoking is associated with a high level of lipoprotein oxidation. In animal experiments, the administration of large amounts of antioxidants inhibits the formation of atherosclerosis and causes the regression of existing lesions. Estrogen is an antioxidant. Estradiol directly inhibits LDL cholesterol oxidation in response to copper and decreases the overall formation of lipid oxides.<sup>1055,1056</sup> Importantly, this antioxidant action of estradiol is associated with physiologic blood levels.<sup>1057</sup> In addition, estrogen may regenerate circulating antioxidants (tocopherols and beta-carotene) and preserve these antioxidants within LDL cholesterol particles.

This antioxidant action of estrogen preserves endothelial-dependent vasodilator function by preventing the deleterious effect that oxidized LDL cholesterol has on endothelial production of vasoactive agents.<sup>1058</sup> In an assessment of peroxide formation by platelets, women treated with both estrogen and medroxyprogesterone acetate in a sequential regimen had greater antioxidant activity compared with the days on estrogen alone.<sup>1059</sup> In a 1-year study, the presence of levonorgestrel did not attenuate the antioxidant activity of estradiol.<sup>1060</sup>

## A Favorable Impact on Fibrinolysis

Menopause is followed by increases in factor VII, fibrinogen, and plasminogen activator inhibitor-1 (PAI-1).<sup>1061,1062</sup> These changes produce a relatively hypercoagulable state and are associated with an increased risk of cardiovascular events. Postmenopausal women treated with estrogen have lower fibrinogen and plasminogen levels. Reduced levels of fibrinogen, factor VII, and PAI-1 have been observed in premenopausal women compared with postmenopausal women, and oral estrogen alone or combined with a progestin prevents the usual increase in these clotting factors associated with menopause.<sup>1063,1064,1065,1066,1067</sup> This would be consistent with increased fibrinolytic activity, a possible cardioprotective mechanism probably mediated, at least partially, by nitric oxide and prostacyclin. Platelet aggregation is also reduced by postmenopausal estrogen treatment, and this response is slightly attenuated by medroxyprogesterone acetate.<sup>1000</sup> In a randomized 1-year trial, the addition of medroxyprogesterone acetate, either sequentially or continuously, produced a more favorable change in coagulation factors compared with unopposed estrogen.<sup>1068</sup>

The transdermal and oral routes of administration of estrogen (combined with medroxyprogesterone acetate) have puzzling differences in the reported effects on most hemostatic risk factors, such as factor VII, fibrinogen, PAI-1, and antithrombin III. In at least one study, antithrombin III levels were reduced by oral estrogen but not transdermal administration; however, the values remained within the normal range.<sup>1069</sup> In regard to PAI-1, studies with transdermal estrogen have provided conflicting data, varying from favorable changes in PAI-1 levels to no effect.<sup>506,1070,1071</sup> However, in a crossover study designed to compare 100 µg transdermal estradiol with 0.625 mg oral conjugated estrogens (both combined with 2.5 mg medroxyprogesterone acetate daily), only the oral estrogen had a favorable reduction in PAI-1 levels.<sup>1071</sup> Appropriate doses of hormone therapy have been reported to not have an adverse impact on clotting factors<sup>1064,1072,1073</sup>; however, the clotting story is difficult to unravel. While no randomized control trials have analyzed the difference in VTE risk between oral and transdermal estrogen, observational studies have demonstrated a difference in risk based on routes of administration. A recent meta-analysis showed that oral estrogen

administration resulted in an increased risk of VTE, which was not seen with transdermal estrogen administration.<sup>1074,1075</sup> Additionally, oral estrogen use in conjunction with progesterone has been associated with a greater risk of VTE than oral estrogen use alone.<sup>1076</sup> Several factors, which are not controlled for in observational trials, also make it difficult to draw a conclusion from the aforementioned data. The frequency (cyclic vs. continuous) and derivative of progesterone used were not controlled for in observational trials. Inherent differences in estrogen's route of administration also likely affected the observed results—estrogens' effects on hepatic first-pass metabolism (namely, oral estrogen's ability to alter the synthesis and clearance of hemostatic proteins), oral estrogens' ability to activate the coagulation cascade, and estrogens' effects on thrombin generation. Thus, a randomized control study comparing the effects of oral versus transdermal estrogen, with or without the addition of progesterone derivative, is needed before a definitive statement regarding the superiority of one form of administration or another can be made.

How can there be favorable changes indicating an increase in fibrinolysis and at the same time an increased risk of venous thrombosis, and why in elderly women, especially those with clinically apparent CHD, does estrogen seem to have a prothrombotic effect? Decreases in antithrombin III and protein S associated with estrogen treatment, a hypercoagulable change, may have a greater impact on the venous system.<sup>1077</sup> There also may be subtle variations of inherited susceptibilities that tilt the balance toward thrombosis; for example, concentrations of factors that favor arterial thrombosis have been reported (tissue factor pathway coagulation inhibitor and thrombin-activatable fibrinolysis inhibitor) in women treated with estrogens.<sup>1078</sup> Another possibility is that the fibrinolysis is a response to coagulation activity and, therefore, not necessarily a beneficial response.

Estrogen has adverse effects on already established atherosclerosis. Matrix metalloproteinase enzymes are secreted by inflammatory cells and smooth muscle cells. These enzymes digest the proteins in the fibrous cap of an atherosclerotic plaque, making the plaque unstable and predisposed to rupture. Estrogen induces matrix metalloproteinase enzymes and decreases their specific inhibitors (TIMP); this is a mechanism involved in the prothrombotic effects of estrogen in the presence of established atherosclerosis. This effect of estrogen may be dose-related and might be avoided with transdermal administration.<sup>1079</sup>

## **Inhibition of Intimal Thickening**

Hypertension and atherosclerosis are associated with increased proliferation of vascular smooth muscle cells. This growth of smooth muscle cells is also characterized by migration into the intima. Arterial intimal thickening is an early indicator of

atherosclerosis. The proliferation and migration of human aortic smooth muscle cells in response to growth factors are inhibited by estradiol, and, importantly, this inhibition is not prevented by the presence of progestins.<sup>1080,1081</sup> Nitric oxide, which is regulated by estrogen, also inhibits smooth muscle proliferation and migration.<sup>1082</sup> Imaging studies have documented a reduction in intimal thickening in postmenopausal women who are estrogen users compared with nonusers, and this beneficial effect is not compromised by the addition of a progestational agent to the treatment regimen.<sup>1029,1083,1084,1085</sup> Thus, postmenopausal hormonal therapy can bring about a reduction in atherosclerosis, and this effect is comparable with that produced by a lipid-lowering drug.<sup>1083,1086</sup>

## **Protection of Endothelial Cells**

Endothelial cells can respond to injury by initiating the clotting process. Animal studies indicate that estrogen accelerates healing and recovery of the endothelium in response to injury.<sup>1087</sup> This is correlated with inhibition of intimal thickening and recovery of important functions such as nitric oxide production. In vitro studies of human endothelial cells demonstrate that estrogen can inhibit cytokine-induced apoptosis.<sup>1088</sup> In the rat, medroxyprogesterone acetate blocked the estrogen-induced healing response after carotid artery injuries.<sup>1089</sup>

## **Inhibition of Macrophage Foam Cell Formation**

A feature of atherosclerotic plaque formation is monocytic infiltration into the arterial wall and the formation of macrophage foam cells. In a non-antioxidant activity, estrogen inhibits macrophage foam cell accumulation in atherosclerotic lesions.<sup>1090</sup>

## **Reduction of ACE and Renin Levels**

Although oral estrogen, but not transdermal estrogen, increases angiotensinogen levels, ACE (angiotensin-converting enzyme) and renin levels are decreased (with or without progestin) by both routes of administration.<sup>1091,1092</sup> The angiotensin II receptor (the AT<sub>1</sub> receptor) is involved in vasoconstriction, aldosterone release, sodium and water retention, and growth and proliferation of myocardial and vascular cells. Estrogen induces down-regulation of the AT<sub>1</sub> receptor, and hypercholesterolemia is associated with AT<sub>1</sub> up-regulation and function.<sup>1093,1094</sup>

## **Reduction of Adhesion Molecules**

Adhesion molecules recruit leukocytes to the endothelium and play a role in attaching platelets to endothelium. Studies with multiple markers report that oral estrogen therapy

increases only CRP, the only marker synthesized in the liver. Although oral hormone therapy increases CRP, it reduces the circulating levels of other markers (E-selectin, P-selectin, intercellular adhesion molecule-1, vascular cell adhesion molecule-1, monocyte chemoattractant protein-1, and tumor necrosis factor- $\alpha$ ) with inconsistent effects on IL-6.<sup>418,421,422,1095</sup> An increase in CRP levels may be due to estrogen's well-known effect to stimulate the hepatic synthesis of proteins, especially because of the first-pass phenomenon with oral administration. For this reason, transdermal estrogen treatment reduces adhesion markers but does not change CRP levels.<sup>419,420,1096</sup>

## **Reduction of Homocysteine**

Increased circulating levels of homocysteine are correlated with increased risks of atherosclerosis and thrombosis. Homocysteine levels increase after menopause and are associated with hypertension and a degree of atherosclerosis.<sup>1097</sup> Homocysteine levels are significantly lowered by estrogen or estrogen-progestin treatment, administered either orally or transdermally.<sup>1098,1099</sup>

# Menopausal Hormone Use and Cardiovascular Disease: Evidence from Observational Studies

A review of case-control studies in the literature finds overwhelming support for about a 50% reduced risk of CHD in estrogen users.<sup>1100,1101,1102,1103,1104,1105,1106,1107,1108,1109,1110,1111,1112,1113,1114,1115,1116,1117</sup> In three studies of women undergoing angiography, a comparison of coronary artery occlusion in users and nonusers of estrogen indicated a significant protective effect of postmenopausal estrogen.<sup>1109,1110,1111</sup> Women using hormone therapy at the time of a myocardial infarction or with congestive heart failure have been reported to have an improved rate of survival.<sup>1118,1119</sup> Little attention has been given to peripheral artery disease, but one case-control study did report a decrease in risk in users of hormone therapy.<sup>1120</sup>

In a large number of cohort studies, most uniformly reported a reduction in CHD in estrogen users; only three produced conflicting data.<sup>1121,1122,1123,1124,1125,1126,1127,1128,1129,1130,1131,1132,1133,1134,1135,1136</sup> In the Nurses' Health Study with 20 years of follow-up, the age-adjusted relative risk of coronary disease in current users of hormone therapy was 39% reduced (RR = 0.61; CI = 0.52–0.71).<sup>1137</sup> The benefit was observed with both the 0.625-mg and the 0.3-mg doses of conjugated estrogens. The beneficial impact was observed to diminish beginning 3 years after discontinuation. It was suggested that higher doses might be harmful because there was an apparent increase in the risk of coronary disease among women taking more than 0.625 mg conjugated estrogens per day. Current postmenopausal hormone users in the Nurses' Health Study have had a 37% reduced risk of mortality due largely to protection against CHD, an effect that was still present after adjusting for dietary factors, alcohol intake, vitamin or aspirin use, and exercise.<sup>1132</sup>

Electron beam tomography (also called ultrafast computed tomography) can assess for the presence of coronary artery disease by quantifying the amount of calcium in the coronary arteries, a measure that is known to correlate with the degree of disease and the risk of coronary events. Studies using this technique have demonstrated a lower prevalence of coronary artery calcium (CAC) in women younger than age 60, a prevalence comparable to men (of any age) in women older than 60, and less calcium (and, therefore, less coronary artery disease) in women using postmenopausal hormone therapy compared with nonusers.<sup>1138,1139</sup> In women with an average age of 59 who had used hormone therapy for an average of 9 years, coronary artery calcification was significantly reduced, with a greater effect observed with increasing duration of use.<sup>1140</sup> This salutary effect of estrogen was confirmed in a substudy of the WHI estrogen-only

arm.<sup>1141</sup>

These observational studies have been criticized by arguing that estrogen treatment is a marker for variables (e.g., better diet and better health care) that place postmenopausal estrogen users in a low-risk group for cardiovascular disease (the “healthy user” effect). And indeed, women who choose to use hormone therapy have been reported to have a better cardiovascular risk profile than nonusers.<sup>1142</sup> This question was addressed by the Lipid Research Clinics Study, the Leisure World Study, and the Nurses’ Health Study.<sup>1125,1143,1144</sup> These epidemiologists concluded that their evidence strongly indicated that in women receiving estrogen treatment who have the same risk factors for cardiovascular disease as those not receiving treatment, the same beneficial effect of estrogen was present. This is especially the case in the Nurses’ Health Study, in which the participants are of a relatively homogeneous socioeconomic group. A cohort follow-up study in Southeastern New England documented similar levels of total cholesterol, HDL cholesterol, BMI, and blood pressure in estrogen users and nonusers, indicating that selection of significantly more healthy women for estrogen use could not fully explain the beneficial effect of estrogen on the risk of cardiovascular disease.<sup>1145</sup> In a comparison of health variables among users and nonusers in South Australia, there was no evidence to support the presence of a “healthy user” effect.<sup>1146</sup> In Chile, users and nonusers of hormone therapy had identical risk factors for cardiovascular disease.<sup>1147</sup>

In contrast to the uniform results from observational studies of the association between postmenopausal hormone therapy and CHD, epidemiologic data over the last 30 years regarding estrogen use and stroke have not been consistent. The many studies have indicated either a small increase or no effect of postmenopausal hormone therapy on the risk of stroke or a reduction in risk associated with estrogen or estrogen-progestin use.<sup>1123,1125,1131,1137,1148,1149,1150,1151,1152,1153,1154,1155,1156,1157</sup> A prospective cohort study in Denmark recorded an increase in ischemic strokes, but only among hypertensive women, and a large cohort study from Sweden found no link between stroke and hormone therapy.<sup>1158,1159</sup>

Within this confusing mixture of results on stroke, there was one consistent observation. The cohort studies (with a sufficient number of cases) that have assessed the impact of hormone use on the risk of death from stroke have all indicated a beneficial impact. For example, the NHANES recruited a very large cohort of women in 1971–1975 for epidemiologic analysis. The follow-up longitudinal study of this cohort yielded a U.S. national sample of 1,910 white postmenopausal women. Postmenopausal hormone use in this cohort provided a 31% reduction in stroke incidence and a strongly significant 63% reduction in stroke mortality.<sup>1152</sup> These relative risks were present even after adjusting for age, hypertension, diabetes, body weight, smoking, socioeconomic

status, and previous cardiovascular disease. This study specifically addressed the criticism that one should expect less disease in estrogen users because they are healthier. After adjusting for physical activity as a marker of general health status, the risk estimates remained identical.

Hypertension is both a risk factor for cardiovascular mortality and a common problem in older people. Studies have either shown no effect or a small, but statistically significant, decrease in blood pressure due to estrogen treatment.<sup>1160,1161,1162,1163,1164,1165</sup> This has been the case in both normotensive and hypertensive women.<sup>1166,1167,1168,1169,1170,1171</sup> The addition of a progestin did not affect this response.<sup>569,1172</sup> Discontinuing hormone therapy in women with hypertension does not result in a decrease in blood pressure (an expected response if the treatment were raising blood pressure), and in some patients, discontinuation is followed by an increase in blood pressure.<sup>1173</sup> The acute administration of estrogen to women with hypertension is followed by decreases in blood pressure, pulse rate, and circulating levels of norepinephrine.<sup>1174</sup> **The very rare cases of increased blood pressure due to oral estrogen therapy truly represent idiosyncratic reactions. Blood pressure should be assessed every 6 months in hypertensive women being treated with postmenopausal hormones, and if the blood pressure is labile, blood pressure should be measured every 3 months.**

Observational studies have also reported that hormone users have a decreased risk of developing venous leg ulcers or pressure ulcers.<sup>1175,1176</sup>



# Menopausal Hormone Use and Cardiovascular Disease: Evidence from Clinical Trials

## The Women's Health Initiative

The WHI was organized by the U.S. National Institutes of Health in 1992 to study the health of postmenopausal women and was scheduled to be completed in 2007.<sup>1177</sup> From 1993 to 1998, the WHI enrolled 161,809 women aged 50–79 in 40 clinical centers. The major components of the WHI were (1) two randomized trials of postmenopausal hormone therapy scheduled to conclude in 2005, (2) a dietary modification trial that randomized 48,000 women to either a sustained low-fat or a self-determined diet, (3) a calcium/vitamin D supplementation trial, and (4) an observational study. One of the randomized trials of postmenopausal hormone therapy, the combined estrogen-progestin arm (daily 0.625 mg conjugated estrogens and 2.5 mg medroxyprogesterone acetate), randomized 16,608 women to either treatment or placebo. The other hormone trial, an estrogen-only arm (daily 0.625 mg conjugated estrogens), randomized 10,739 hysterectomized women to treatment or placebo.

On May 31, 2002, the Data and Safety Monitoring Board (DSMB) made its periodic review of the data accumulated by the WHI. The DSMB made two recommendations that were announced on July 9, 2002: (1) to discontinue the trial arm administering daily estrogen-progestin and (2) to continue the trial arm with daily unopposed estrogen in hysterectomized women. The combined estrogen-progestin arm was discontinued after about 5 years of follow-up because of a statistically significant increase in invasive breast cancer and an increase in cardiovascular events.<sup>1178</sup> The statistical parameters for benefit or harm were established in 1997 early in the study. When the increase in breast cancer exceeded the predetermined boundary, the DSMB was obligated to recommend discontinuation of this arm of the trial.

On March 2, 2004, the National Heart, Lung, and Blood Institute of the U.S. National Institutes of Health canceled the estrogen-only arm of the WHI. This arm of the WHI included 10,739 hysterectomized, postmenopausal women who had completed an average of 6.8 years of follow-up. The WHI Data and Safety Monitoring Board made their last periodic review of the study data in December 2003. The DSMB was not unanimous in its decision; some members wanted to stop the study, and others wanted the study to continue after sending a letter to the participants describing the findings. Even though none of the findings had crossed the predefined boundaries, the NIH made the decision to stop the study on February 2, 2004. The decision was based on the following results<sup>1179</sup>:

- An increased risk of stroke similar to that reported in the canceled estrogen-progestin arm of the WHI
- No increase or decrease in CHD
- A trend toward an increased risk of probable dementia and/or mild cognitive impairment
- A reduction in hip fractures
- No increase in breast cancer

**With the exception of breast cancer and CHD, the results in the estrogen-only arm were essentially identical to those in the estrogen-progestin arm of the study.** But keep in mind that the populations in the two clinical, randomized trial arms of the WHI were not identical.<sup>1180</sup> Considering risk factors for cardiovascular disease, the women in the estrogen-only arm were more obese, were less active, and had more pre-existing cardiovascular disease. The estrogen-only arm also differed in regard to risk factors for breast cancer: more early births and bilateral oophorectomy and more and longer duration of previous hormone therapy. **Therefore, these were two different trials with two different populations and treatments, making direct comparisons inappropriate.**

**The published results of the WHI trial agree with more than 30 years of case-control and cohort data with the exception (as first presented by the WHI) of the cardiovascular results.** The updated results on the risk of CHD from the canceled estrogen-progestin arm of the WHI reflected central adjudication of the cardiac diagnoses in contrast to the initial report that relied on local diagnoses.<sup>1181</sup> The final report covered an average of 5.6 years of follow-up, compared with 5.2 years in the initial report. Based on these data, there would be an increase of six cases of CHD per 10,000 women per year in the treated group.

Central adjudication disagreed with 10% of the diagnoses for myocardial infarction and 3% for death due to CHD. This small degree of disagreement changed the strength of the conclusions comparing the initial report<sup>1178</sup> with the updated report. Indeed, the overall results by definition did not achieve statistical significance in the follow-up report, and only the first year results were statistically significant in the year-by-year analysis, a conclusion based on a difference of only 19 cases. In all of the WHI reports, the intent-to-treat analyses were adjusted for multiple outcomes, the Bonferroni adjustment. All adjusted results were not statistically significant. It is difficult to understand the clinical meaning of this manipulation, but most believe that this indicates a slightly lower mathematical conclusion than presented in the nonadjusted data. This, of course, would further weaken the power of the reported results.

Consider also the possibility of diagnostic bias. 40.5% of the estrogen-progestin

group in the WHI (nearly 5,000 of the 8,500 in the treated group), in contrast to 6.8% of the placebo group, were unblinded because of vaginal bleeding. What was the impact on the clinicians' final management and diagnosis when told that the patient is in the WHI study and experiencing vaginal bleeding? This problem affects the data not only in regard to cardiovascular disease but also for breast cancer. Unblinding was not a problem in the estrogen-only arm of the WHI and no increase in CHD was recorded—was this because of an absence of diagnostic bias in the estrogen-only arm?

The characteristics of the participants in the two WHI hormone trials are noted in [Table 17.12](#).

## **TABLE 17.12 WHI Hormone Trials**

	Estrogen-Progestin Arm	Estrogen-Only Arm
Average age	63.3 y	63.6 y
Drop-out rate	42%	53.8%
Drop-in rate (began hormone use)	6.2%	5.7%

The women in the estrogen-progestin arm were an average of slightly more than 12 years distant from menopause.<sup>1179</sup> Most had been without hormone therapy for more than a decade. In the estrogen-only arm, the published results do not specify the number of years distant from menopause, but this duration may have been even greater, influenced by the age of subjects at the time of bilateral salpingo-oophorectomy. Women with significant menopausal symptoms were excluded from the study to avoid an exceedingly high drop-out rate in the placebo group. Women who had been on hormone therapy (about 25% of the participants in the estrogen-progestin arm and 35% in the estrogen-only arm) and then underwent a 3-month “washout” period and experienced menopausal symptoms were discouraged from participation (about 12.5% of the participants in the estrogen-progestin arm reported vasomotor symptoms on entry but were willing to be assigned to placebo, and, therefore, their symptoms were unlikely to have had a major disturbing effect). This exclusion means that only a small number of women in the WHI were close to their age of menopause (about 16.5% of the participants in the estrogen-progestin arm were <5 years since their menopause). For example, there was only a total of 574 women who were age 50–54 in the estrogen-progestin arm.<sup>301</sup>

Over the time of the studies, the participants discontinued their medication at a consistently increasing rate, so that at termination, about half were no longer adhering to treatment. The WHI investigators argued that the high drop-out rate could lead to an underestimation of adverse effects; however, this would not be the case if longer duration of treatment exerts a beneficial effect. For example, a case-control study in the United Kingdom found a significant reduction in the risk of myocardial infarction only

with the use of hormone therapy for more than 5 years.<sup>1182</sup> Indeed, a trend for an emerging protection against CHD was observed in both arms of the WHI with increasing duration of treatment. Analysis of subsamples in the WHI revealed that the treated group had greater reductions in total cholesterol, LDL cholesterol, glucose, and insulin levels and greater increases in HDL cholesterol and triglyceride levels. It is tempting to link these findings with the test for trend that revealed a favorable, decreasing relative risk of CHD over time, which was statistically significant. However, this analysis was hampered by decreasing numbers over time, and the conclusion was not a strong one.

**In subgroup analyses, only the women in the estrogen-progestin arm who were 20 or more years distant from menopause had a statistically significant increased risk of CHD. Subtracting this group from the rest of the participants, CHD now was observed in an identical prevalence comparing the treated and placebo groups. It is not appropriate to conclude, based on the WHI, that hormone therapy increases the risk of coronary clinical events in all postmenopausal women; this conclusion can only be applied to a specific older group of women. Indeed, as early as 2004, the data from the estrogen-only arm suggested that younger women experienced a reduced risk of CHD with estrogen treatment.<sup>1179</sup>**

A reanalysis of the CHD data in the canceled estrogen-progestin arm of the WHI, published 7 years after the initial report, contributed nothing new, confirming that a statistically significant increase in coronary heart events occurred only in the women 10 or more years distant from their menopause.<sup>1183</sup>

One response to the publications from the WHI has been a scientific and clinical effort to assess and use lower doses of estrogen. Half of the standard dose of CEEs has been demonstrated to effectively treat menopausal symptoms and to prevent bone loss. It is reasonable to ask whether symptoms and bone are especially sensitive to the effects of estrogen and whether lower doses of estrogen will beneficially impact other target tissues. The cardiovascular system is of obvious concern because it was already apparent that lower doses of estrogen do have a lesser effect on circulating lipids and lipoproteins.

Clarkson and his colleagues studied the effects of a lower-dose estrogen trial in a monkey model of coronary atherosclerosis.<sup>1184</sup> The animals were fed an atherogenic diet for 10 months, calculated to induce atherosclerosis comparable to that observed in early postmenopausal women. After oophorectomy, the animals were randomized to treatment for 2 years with a placebo or a dose of CEEs equivalent to 0.3 mg/day in women. This dose had no effect on circulating lipid levels; nevertheless, the treated animals had an average of 52% reduction in coronary atherosclerosis. This degree of protection was similar to studies in this model using a dose of conjugated estrogens

equivalent to 0.625 mg/day.

The reliability and value of results obtained in Clarkson's monkey model have stood the test of time. Repeatedly, results from this model proved to be predictive of hormonal effects in women. Therefore, this experiment using a lower dose of estrogen is important, providing information regarding the effect of a lower dose on coronary atherosclerosis. Consistent with some reports in women, the lower dose of estrogen had no effect on levels of LDL cholesterol, HDL cholesterol, or triglycerides. But the treatment markedly reduced the extent of coronary artery atherosclerosis, a further indication that estrogen-induced inhibition of atherosclerosis occurs to a large extent independently of changes in lipids and lipoproteins. In the dose-response clinical trial that led to FDA approval of lower doses of CEEs, the 0.3-mg dose still produced statistically significant beneficial changes in lipids and lipoproteins, and this dose prevented bone loss.<sup>577,583</sup>

## The WHI and Stroke

The WHI reported an overall increase in the estrogen-progestin arm of ischemic stroke, but no increase in fatal strokes.<sup>1178,1185</sup> The increase in nonfatal ischemic stroke in the estrogen-only arm of the WHI was of similar magnitude.<sup>1159,1186</sup> A randomized, double-blind, placebo-controlled secondary prevention trial (the WEST trial) of daily 1 mg estradiol therapy was conducted in postmenopausal women after a recent (within 90 days) ischemic stroke or transient ischemic attack (25% of the women).<sup>1187</sup> After an average of 2.8 years of follow-up (range 16–50 months), there were no significant overall differences comparing the treatment and placebo groups in any of the assessed outcomes, including nonfatal stroke, fatal stroke, coronary death, nonfatal myocardial infarction, or transient ischemic attack. The WEST trial retrospectively analyzed the time course of cerebrovascular events and found a significantly increased risk of stroke only at 6 months based on 21 strokes in the estradiol group and 9 strokes in the placebo group.

A major limitation of the WEST study was the reduced compliance with treatment because of the problems associated with unopposed estrogen treatment. Over a 3-year period, 116 women in the estradiol group discontinued treatment (34%) compared with 79 in the placebo group (24%). **Nevertheless, the clinical meaning is straightforward: patients should not be given estrogen treatment after a vascular event in the expectation that recurrent vascular events would be prevented by the initiation of estrogen treatment. However, this recommendation is specifically targeted to women with existing vascular disease.**

The Nurses' Health Study reported an update of its data on the use of hormone therapy and stroke, focusing on the timing of initiation of treatment and the effect of

estrogen doses.<sup>1188</sup> In the analyses adjusted for age, BMI, cholesterol levels, diabetes, hypertension, smoking, and family history of early CHD, the following relative risks were observed for ischemic stroke (there was no significant increase in hemorrhagic stroke):

**Current use of estrogen alone:** RR = 1.43 (CI = 1.17–1.74)

**Current use of estrogen-progestin:** RR = 1.53 (CI = 1.21–1.95)

Comparing initiation of hormone therapy near menopause with initiation 10 or more years after menopause, there was no major difference.

The Nurses' Health Study also reported an increasing risk of stroke with an increasing dose of estrogen (Table 17.13).

**TABLE 17.13 Estrogen Dose and Stroke Risk**

TABLE 17.13 Estrogen Dose and Stroke Risk		
0.3 mg estrogen	25 cases	RR = 0.93 (CI = 0.62–1.40)
0.625 mg	268 cases	RR = 1.54 (CI = 1.31–1.81)
1.25 mg	60 cases	RR = 1.62 (CI = 1.23–2.14)

It is not easy to derive a take-home message from the Nurses' Health Study report. The authors stated that their findings are “virtually identical to those of the WHI trials.” However, in the last report from the WHI, when women with prior cardiovascular disease or those older than 60 years were excluded, the risk of stroke with hormone use in women less than 10 years since their menopause was not significantly increased.<sup>1189</sup> Therefore, there is disagreement.

In women with risk factors for stroke, it is prudent to use low doses of estrogen and to vigorously address the risk factors, such as effective treatment of hypertension. Would the transdermal route of hormone administration be safer? This is an important question that cannot be categorically answered because of lack of high quality prospective data. However, as has been discussed earlier in this chapter, it is quite plausible that transdermal HT confers a lower risk of thrombosis

**compared to oral formulations. Therefore, it seems wise to preferentially recommend transdermal route of HT for older postmenopausal hormone users.**



# Secondary Prevention Randomized Clinical Trials

## The Heart and Estrogen-Progestin Replacement Study

HERS was a randomized, double-blind, placebo-controlled clinical trial designed to determine whether daily treatment with 0.625 mg conjugated estrogens and 2.5 mg medroxyprogesterone acetate would reduce CHD events in women with pre-existing coronary disease.<sup>1190,1191,1192</sup> 2,763 women (average age 66.7 years) were enrolled in 20 U.S. clinical centers and randomized to treatment and placebo beginning in February 1993 and ending in July 1998. Overall, there were 172 myocardial infarctions and coronary deaths in the hormone group and 176 in the placebo group—no difference.

At baseline, the use of statins and aspirin was essentially equally prevalent in the treated and placebo groups (about 40% of the subjects used statins and 80% used aspirin). However, more women in the placebo group began treatment with statins, so that by the end of the follow-up period, the 69% versus 65% difference comparing placebo with treatment was statistically significant. The authors addressed this potential confounder by adjusting for the difference in statin use (as well as other confounders) and concluded that the adjusted analyses were essentially identical to the original analyses. However, no mention is made of the fact that the percentage use of statin use is impressively high. What if any beneficial effect of estrogen is lost because of the impact of statin therapy? Indeed, in a primary prevention trial, inhibition of atherosclerosis with estrogen treatment was observed only in women not receiving statins.<sup>1193</sup> The HERS investigators compared CHD events in the hormone group with the placebo group in women not using statins or aspirin and found no difference, but this very important possible explanation for the lack of a beneficial effect of estrogen in HERS cannot be answered by the analysis of the HERS data because statin and aspirin treatments were not randomized and the number of events in women not on statins or aspirin was very small.

Of the 2,763 postmenopausal women in the HERS trial, 2,321 (93%) agreed to be involved in additional follow-up evaluation, HERS II. The original study<sup>1190</sup> lasted 4.1 years, and the average extended follow-up equaled 2.7 years, for a mean total of 6.8 years. At the beginning of the follow-up period, the average age of the participants was 71 (67 at baseline and 74 at closure). The investigators could detect no significant differences in the rates of coronary events or secondary cardiovascular events comparing the treated group with the placebo group. There was no statistical trend for a beneficial effect of hormone therapy with longer duration of treatment. Because of the absence of a difference, the follow-up period, scheduled to last 4 years, was terminated

early.

The additional follow-up period was unblinded; patients and physicians could choose to continue, discontinue, or initiate hormonal or other therapy. Hormone use in the original treated group in HERS declined from 81% after 1 year to 45% during the sixth year (and 11% were using preparations other than the original 0.625 mg conjugated estrogens and 2.5 mg medroxyprogesterone acetate). During the sixth year, 8% of the placebo group were now receiving hormone therapy. Raloxifene or tamoxifen had even been initiated, 3% in the hormone group and 4% in the placebo group. The investigators recognized this problem conceding that their power to detect an increasing benefit was eroded by the changing treatments; however, their analysis indicated an ability to detect at least an 18% reduction in cardiac risk.

The original HERS report indicated a two- to threefold increase in deep vein thrombosis and pulmonary embolism in the hormone-treated group. In the follow-up period, there was no longer a statistically significant increase in deep vein thrombosis. There was no reduction in pulmonary embolism, but the number of events was too small to provide accurate assessment. The event rates for venous thrombosis were 5.9 per 1,000 women per year of treatment and 2.8 in the placebo group. Overall, there was a 48% increase in risk for biliary tract surgery in the treated group, 6 more cases per 1,000 women per year compared with placebo.

Intention-to-treat analysis compares all individuals in the treated group to all in the placebo group, regardless of individual compliance or completion of the study. Proponents argue that this is the best method of analysis for clinical trials because it reflects the full impact of randomization. Opponents contend that this method is intuitively wrong; how can the long-term benefit of a treatment be assessed if subjects receiving treatment for only a short period of time are included? HERS II performed an “as-treated” analysis, focusing on women with 80% or more compliance, and found relative hazards (like relative risk) similar to those in the intent-to-treat analysis. However, the relative hazard in the as-treated analysis for primary CHD events in HERS II was reduced, although not statistically significant (RH = 0.81; CI = 0.52–1.32). Events were fewer in the as-treated analyses because only 37% of the events qualified. Adjustment for statin use was performed only in the intent-to-treat analysis (“only a trivial effect on the findings”). The HERS clinical trial results that reflect intent-to-treat analyses are compromised by a difficulty in detecting a long-term effect, and the results that reflect the as-treated analysis are compromised by few events because of compliance and drop-out problems. Therefore, unanswered questions remain: whether reported increases in cardiovascular events early after the initiation of hormone therapy reflect a true risk of hormone therapy or the effect of reduced events in the placebo groups because of new-onset treatment with statins and aspirin, or an effect limited to women with significant preexisting coronary artery disease.

## Other Secondary Prevention Trials

The results of a multicenter trial (the Estrogen Replacement and Atherosclerosis [ERA] trial) examined the effect of postmenopausal hormone therapy on the progression of coronary atherosclerosis as assessed by angiography.<sup>1194</sup> A total of 309 women were randomly assigned to receive either unopposed estrogen, 0.625 mg conjugated estrogens per day; a daily combination of estrogen and progestin, 0.625 mg conjugated estrogens and 2.5 mg medroxyprogesterone acetate; or placebo. Over 3.5 years of treatment, angiography did not detect any differences in disease progression between any of the groups. The women in this study had documented heart disease on entry and were a relatively older group of women (mean age 65.8 years). Half had a previous myocardial infarction. There were no reported increases in cardiac events in any of the three treatment groups.

The ERA trial joins the HERS trial in demonstrating no secondary preventive effect of postmenopausal hormone therapy on older women with significant CHD. However, **in comparing the two trials, there is an important observation. The ERA trial contained an estrogen-only arm, and the absence of a difference between the estrogen-only arm and the estrogen-progestin arm argues against a negative effect due to the daily administration of medroxyprogesterone acetate.**

Another secondary prevention, 3-year trial (Women's Estrogen-progestin Lipid-Lowering Hormone Atherosclerosis Regression Trial, WELL-HART) assessed whether unopposed estradiol or a sequential regimen of estradiol and medroxyprogesterone acetate could slow the progression of atherosclerosis.<sup>1195</sup> The double-blind, placebo-controlled trial involved 226 postmenopausal women with an average age of 63.5 years (range 48–75), who already had at least one demonstrated coronary artery lesion. The results were based on follow-up angiograms in 59 women in the placebo group, 54 in the estradiol group, and 53 in the estradiol-medroxyprogesterone acetate group. A reduction of LDL cholesterol to less than 130 mg/dL was achieved by dietary intervention, but coronary angiography to measure the change from baseline in the percent stenosis failed to demonstrate a difference among the groups receiving placebo; unopposed, daily 1 mg estradiol; or daily 1 mg estradiol and 12 days each month of 5 mg medroxyprogesterone acetate. **There were also no differences in cardiovascular events during treatment. The results indicated that medroxyprogesterone acetate administered in a sequential regimen is not associated with an adverse cardiovascular effect.**

At least three other secondary prevention trials in women with CHD failed to demonstrate a beneficial impact of hormone therapy.<sup>1196,1197,1198</sup> These various trials tested oral conjugated estrogens, oral estradiol valerate, and transdermal estradiol

combined with either medroxyprogesterone acetate or norethindrone. **The results of the secondary prevention trials in older women with established heart disease are uniformly consistent in finding no beneficial effects of hormone therapy, and the data indicate that different estrogens and different progestins behave similarly.**

# The Timing Hypothesis

The timing hypothesis argues that estrogen can reduce the risk of CHD when administered to relatively young postmenopausal women before atherosclerosis has developed to the stage of unstable plaques (plaques with necrosis and inflammation).

The WHI investigators conducted a secondary analysis of the two canceled clinical hormone trial arms.<sup>1189</sup> The results in the estrogen-only arm, in the combined estrogen-progestin arm, and with the participants combined were separated into age groups at randomization (50–59, 60–69, and 70–79) and according to years since menopause (<10, 10–19, and 20 or more). **An increased risk for CHD was present only in the oldest women in the trials. There were no increases for CHD, stroke, or total mortality in women aged 50–59. In fact, only the increase in CHD events in women 20+ years since menopause reached statistical significance. There was no apparent increase in cardiovascular disease risk in treated women close to their menopause. Indeed, a statistically significant reduced risk was present for total mortality in women aged 50–59.**

The data in this 2007 WHI report were not new. A careful reading of the initial adjudicated reports reveals that the risk of CHD was present only in the oldest women in the trials.<sup>1181,1199</sup> In subgroup analyses, the only significant increase in stroke occurred in the estrogen-only arm in women aged 60–69. But as noted previously, when women with prior cardiovascular disease or those older than 60 years were excluded, the risk of stroke in women less than 10 years since their menopause was not significantly increased. In a meta-analysis of RCTs examining CHD outcomes when HT was used in younger versus older women, lower CHD was noted in the younger group.<sup>1200</sup> To further assess the effects of ET on coronary health, CAC was measured in women aged 50–59 years by computed tomography (CT). Calcium atheromas are indicative of the chronic inflammatory process associated with atherosclerosis and are the best known predictors of clinical heart disease. As such, calcium atheroma scores were used to assess cardiovascular disease. Women in the ET group had a statistically significant lower calcium atheroma score than those in the placebo group ( $p = 0.02$ ). Moreover, in participants with greater than 80% adherence (to ET or placebo), there was a 61% lower risk of severe coronary calcium in the ET group ( $p = 0.002$ ).<sup>1200</sup>

Will postmenopausal hormone therapy begun at or near the time of the menopause, and maintained for a relatively long duration of time, provide protection against coronary artery disease (primary prevention)? The design of the canceled arms of the WHI did not allow an answer to this question. As previously noted, women with significant menopausal symptoms were excluded from the study to avoid an exceedingly high drop-out rate in the placebo group. The WHI addressed this problem by pointing

out that the ratios of cardiovascular events in the treated and placebo arms were the same when assessed by decades of age, 50s, 60s, and 70s. However, this was not the critical analysis. By excluding women with menopausal symptoms, it is very likely that a small number of the participants were close to their age of menopause. Only 574 in both the treated and placebo groups were age 50–54 in the estrogen-progestin arm, and it is likely that even some of these women were relatively distant from their menopause. Even with the appropriate analysis according to years from menopause, the results are limited by very small numbers of women in their early postmenopausal years. Furthermore, the high drop-out rates in these clinical trials erode the statistical power for assessing year-by-year new statin or aspirin treatment.

There is a small primary prevention trial of 199 healthy postmenopausal women randomized to a daily dose of 1 mg estradiol or placebo and followed for 2 years measuring with ultrasonography the change in carotid artery intimal-medial thickness.<sup>1193</sup> The women receiving estradiol had a small decrease in intimal-medial thickness in contrast to a marked increase in the placebo group. Interestingly, in those participants taking lipid-lowering medications, there was no difference comparing estrogen treatment with placebo (both groups had a small decrease in thickness), indicating that lipid-lowering drugs and estrogen had similar beneficial effects on atherosclerosis that were not additive. There have been two other similar ultrasonography studies. A 2-year Dutch study did not achieve a significant difference comparing treatment with placebo, but the results were handicapped by a very high drop-out rate and problems with follow-up.<sup>1201</sup> A German study that found no effect of hormone therapy enrolled women who already had increased intimal-medial thickness, and the duration of the study was only 1 year.<sup>1202</sup>

A meta-analysis of 23 randomized hormone therapy trials concluded that treatment reduced the risk of CHD events by 32% in younger women compared with older women (10 or more years since menopause or >60 years of age).<sup>469</sup> This is a conclusion that is less firm than at first apparent, because most of these trials were not designed to measure an endpoint of cardiovascular disease. However, another meta-analysis by the same authors concluded that hormone therapy reduced overall mortality in women with an average age of less than 60.<sup>470</sup> There is a growing story that adequate estrogen exposure prior to the onset of clinical events provides protection against cardiovascular disease.

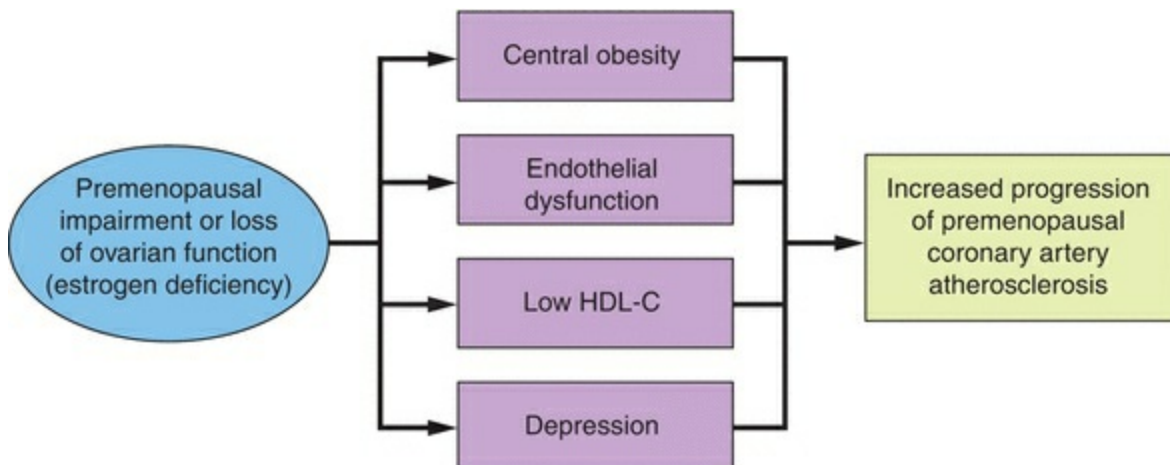
The timing hypothesis originated in the hormone trials conducted in monkeys by the Wake-Forest group headed by Tom Clarkson and provides some of the initial support of the timing hypothesis.<sup>468</sup>

## Key Points: Timing Hypothesis

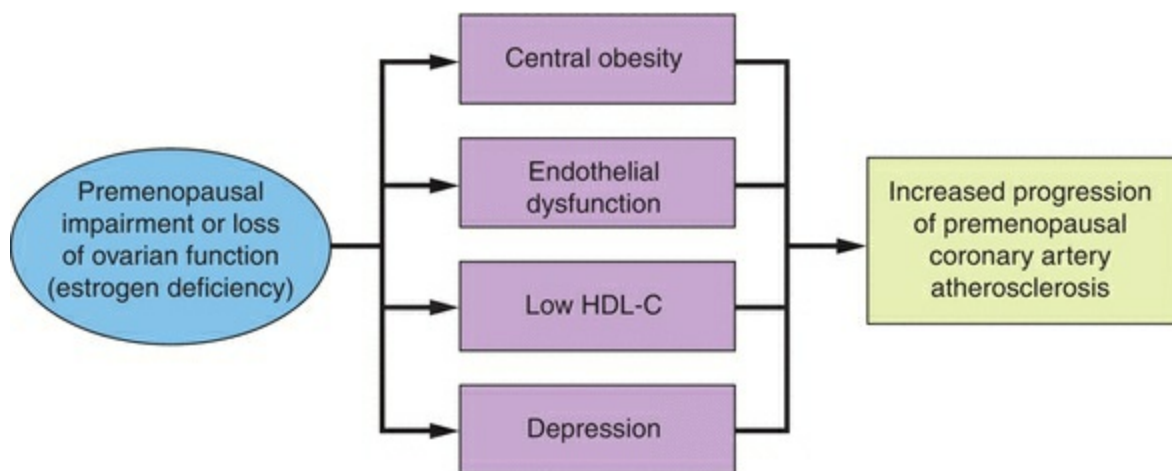
- Estrogen treatment initiated immediately after menopause in monkeys inhibited progression of coronary artery atherosclerosis by about 70%. When treatment was delayed by 2 years (equivalent to about 6 years in women), there was no effect.<sup>468</sup>
- Next in line, according to strength of evidence in our view, would be the WHI reports of reduced coronary artery calcium in estrogen-treated women and an increase in cardiac events only in the oldest women in the trials.<sup>1141,1189</sup> The problem of low event rates in younger women in the WHI was addressed by lumping together, in one hazard ratio, myocardial infarction, coronary death, coronary revascularization, and confirmed angina—the risk in women aged 50–59 years for all of these events was significantly reduced (HR = 0.66; CI = 0.45–0.96).<sup>1199</sup> In addition, the WHI measured coronary artery calcium in a substudy of the estrogen-only arm and found that women with bilateral oophorectomies who were not treated with estrogen had an increase in subclinical coronary heart disease.<sup>1203</sup>
- Every woman has a trajectory of atherosclerosis development, the slope of which determines the age of onset for clinical events. Premenopausal women with lower estrogen levels have higher cardiovascular risk factors and develop more and earlier coronary heart disease.<sup>1204</sup>
- The importance of premenopausal estrogen is also supported by Clarkson's monkey studies. Premenopausal monkeys with normal ovarian function have less progression of coronary artery atherosclerosis as compared with monkeys with impaired ovarian function.<sup>468</sup>
- The Mayo Clinic Cohort Study of Oophorectomy and Aging included 1,274 premenopausal women with unilateral oophorectomy (followed for a median of 29.5 years) and 1,091 premenopausal women with bilateral oophorectomy (followed for a median of 25 years) who had surgery from 1950 to 1987, compared with 2,383 matched women from the same population of women who had not undergone oophorectomy.<sup>1205</sup> Women with bilateral oophorectomy before age 45 had about a fivefold increase in risk of mortality for neurologic or mental diseases and experienced almost a twofold increase in mortality from cardiovascular disease, increased risks of parkinsonism, cognitive impairment and dementia, and an increase in depressive and anxiety symptoms later in life (**Figures 17.16**).<sup>1206,1207,1208,1209</sup>
- The Nurses' Health Study compared, after 24 years of follow-up, ovarian conservation (13,035 women) and bilateral oophorectomy (16,345 women) at the

time of premenopausal hysterectomy.<sup>1210</sup> An all-cause increase in mortality, coronary heart disease, and stroke was observed in those women who never used estrogen after surgery; this amounted to one additional death for every nine surgeries.

- The results in observational studies strongly indicate that hormone treatment of young postmenopausal women reduces the risk of coronary heart disease. In the Nurses' Health Study, the reduction was approximately 50%.<sup>1137</sup> The women in the Nurses' Health Study who were under age 60 when hormone treatment was initiated had a significant reduction in coronary heart disease risk compared with no effect in women over age 60.<sup>1211</sup> A similar reduction was present in the observational arm of the WHI.<sup>1212</sup> In fact, after adjustment for confounding influences in the WHI observational arm such as behavioral, dietary, physical activity, and cardiovascular risk factors, the relative risks for cardiovascular events were 30–38% lower than in the clinical trials. These data were derived from populations of women usually treated with postmenopausal hormone therapy, women close to their natural age of menopause.
- In a primary prevention trial using ultrasound measurement of carotid artery intima-media thickness, estradiol-treated women had slower progression of atherosclerosis.<sup>1193</sup> These same investigators demonstrated no effect of estrogen treatment in older women who had angiographic evidence of coronary atherosclerosis.<sup>1195</sup>







**FIGURE 17.16**

## **Primary Prevention Randomized Clinical Trials Addressing the Timing Hypothesis**

**Kronos Early Estrogen Prevention Study (KEEPS)** was a randomized, double-blind placebo-controlled trial aimed at assessing the effects of early initiation of oral or transdermal HT on progression rates of subclinical atherosclerosis.<sup>1213</sup> Women were eligible for enrollment if they were healthy, aged 42–58 years, between 6 and 36 months from their last menstrual period with no prior CVD events, a CAC score less than 50 Agatston units, and without exogenous estrogen exposure or lipid-lowering therapy for the past 90 days. Women were randomized to receive oral (o) CEE 0.45 mg/day, or transdermal (t) E2 50 µg/day, each with 200 mg oral progesterone for 12 days per month, or placebo for 48 months. The primary endpoint was annual change in carotid artery intima-media thickness (CIMT) by ultrasonography, with secondary endpoints of changes in markers of CVD risk, including CAC scores (determined by computed tomography scan of the chest).<sup>1213</sup> Of the 727 randomized women, 89.3% had at least one follow-up CIMT, while 79.8% had a CIMT annually. The KEEPS trial found that the mean CIMT increase of 0.007 mm/year was similar among all three groups. Similarly, the percentage of subjects in whom CAC scores increased was not different. LDL and HDL levels improved, levels of CRP and SHBG increased with o-CEE, but IL-6 did not. Insulin resistance decreased with t-E2; there were no changes in blood pressure with either o-CEE or t-E2 use.<sup>1213</sup> Thus, the KEEPS trial did not demonstrate a significant difference in CIMT (a measure of preclinical progression of atherosclerosis) among oral, transdermal, or placebo groups. In a follow-up of a subgroup of subjects (representative of the placebo, o-CEE, and t-E2 groups) 3 years after stopping HT from the KEEPS trial, the effects of cessation of HT on CIMT were analyzed.<sup>1214</sup> There did not appear to be a “rebound” effect on CIMT progression upon discontinuation of o-

CEE or t-E2.<sup>1214</sup> Regardless of HT regimen, there was an overall increase in CIMT over time, which may be inherent to the aging process.<sup>1214</sup>

**Early versus Late Intervention Trial with Estradiol (ELITE)** also assessed the effect of early administration of HT on the development/progression of atherosclerosis.<sup>1215</sup> Six hundred and forty-three healthy postmenopausal women are stratified by years since menopause (early equal to <6 years or late [>10 years]) and randomly assigned to oral E2 1 mg/day plus vaginal progesterone 45 mg for 10 days/month for women with a uterus or placebo (including sequential vaginal gel for subjects with a uterus). The primary outcome was the rate of change in CIMT (measured every 6 months). Secondary outcomes included assessment of coronary artery atherosclerosis by cardiac CT scan (performed at completion of study medication). Following 5 years, it was found that oral E2 with/without vaginal progesterone resulted in a significantly slower increase in CIMT in the early postmenopause group, compared to placebo.<sup>1215</sup> In women who were greater than 10 years past menopause, CIMT progression rates were not different from placebo. Measures of CAC by CT, total stenosis, and plaque burden did not differ between placebo groups and the estradiol groups for early or late menopause status.<sup>1215</sup> Thus, unlike KEEPS, results of the ELITE trial support the timing hypothesis in that early initiation (i.e., closer to the timing of menopause) of HT was associated with more favorable cardiovascular outcomes. The differences between ELITE and KEEPS may, among many possibilities, relate to inherent differences in the studied populations or reflect differences in the choice and dose of estrogen formulations utilized.<sup>1216,1217</sup>

## Key Points: Hormones and CHD

- **The message from multiple secondary prevention trials is clear: exogenous estrogen should be avoided in postmenopausal women with existing CHD, and there are no grounds for an expectation that such treatment will reduce subsequent cardiac events.**
- **Evidence from primary prevention clinical trials, while less clear, suggests that early initiation of estrogen may confer cardioprotective effects (as evident in the ELITE trial); however, additional studies are needed to establish consistency of such a benefit across populations and to clarify if such benefit may depend on the type and dose of estrogen formulation given the discrepant findings between ELITE and KEEPS trials. Until clarity is attained, cardioprotection alone should not be used as an indication for prescribing hormone therapy.**

- **A reasonable goal is to maintain a healthy level of estrogen during the premenopausal years and in the early postmenopausal period.**
- **Experimental evidence in the monkey indicates that the beneficial effects of hormonal treatment are progressively diminished with increasing atherosclerosis.**<sup>1216</sup>
- **In postmenopausal women, the vasodilatory effects of estrogen dissipate with increasing age.**<sup>1217</sup>

# VENOUS THROMBOSIS

---

Results from multiple studies indicate that postmenopausal hormone therapy increases the risk of VTE about twofold, mostly in the first year or two of treatment, a conclusion supported by the results from the canceled estrogen-progestin arm of the WHI.<sup>1178,1218</sup> The absolute risk in the WHI estrogen-progestin arm was 18 additional cases per 10,000 women per year. In the estrogen-only arm of the WHI, a smaller increase in deep vein thrombosis was observed, and an increase in pulmonary embolism was not statistically significant.<sup>1179,1219</sup> There are some notable observations in the WHI data on venous thrombosis. Most of the cases occurred in the first 2 years of exposure, and the risk was greatest in the women over age 70 and in overweight women. The risk was higher in women who were susceptible to venous thrombosis, specifically those with the Leiden mutation. This raises a very important question: is it possible that the risk of venous thrombosis is very low in younger, normal postmenopausal women?

**It should be emphasized that the risk of VTE appears to apply only to new hormone starters; women who have been on hormone therapy can be reassured that the evidence indicates that the increased risk of venous thrombosis is concentrated in the first 1–2 years of treatment.<sup>1076</sup> The actual risk is very low because of the low frequency of this event. If the relative risk is increased twofold, this would increase the incidence of VTE by about 2 cases per 10,000 women per year of hormone use. Furthermore, venous thrombosis carries with it a very low risk of mortality, around 1%, and most of the fatal cases have followed venous thrombosis associated with trauma, surgery, or a major illness.<sup>1220</sup>**

VTE is a risk that is reduced with the use of statins and low-dose aspirin,<sup>1221,1222</sup> although it is not known whether statin and aspirin use would completely protect against the increased risk associated with postmenopausal use of hormone therapy.

Accruing data are reassuring in regarding lesser VTE risk with transdermal route of estrogen compared to oral use, a benefit that is attributed to avoidance of the first-pass hepatic effect with nonoral route. For example, oral administration of estrogen compared with transdermal administration in male-to-female transsexuals is associated with a greater prothrombotic state and risk of venous thrombosis; however, this effect could be at least partly attributed to major differences in the estrogen doses.<sup>1223</sup> It would be better to have evidence uninfluenced by dosage, and for this purpose, we can consider responses of APC resistance, recognized as a marker for venous thrombosis risk. In one randomized trial, oral estrogen treatment increased APC resistance, but transdermal estrogen was no different than placebo.<sup>511</sup> Another randomized trial found that both routes of administration increased APC resistance; however, the increase with

oral estrogen was about 4 times greater compared with transdermal estrogen.<sup>510</sup> A French case-control study concluded that there was a fourfold increase in VTE with current use of oral estrogen but no increase in risk with transdermal estrogen.<sup>512</sup> In addition, this study reported that oral estrogen treatment adds to the risk of VTE associated with obesity, but transdermal estrogen does not.<sup>1224</sup> The French study also reported (although limited by small numbers) that transdermal treatment, in contrast to oral estrogen, does not further increase the risk of VTE associated with known prothrombotic conditions such as factor Leiden or prothrombin mutations.<sup>513</sup>

However, there are some problems with the French case-control study. There are wide confidence intervals for the significant odds ratio associated with oral estrogen treatment. Usually, this reflects small numbers, but the number of cases and controls in this study should allow greater precision. It is possible that this imprecise conclusion is influenced by the fact that the cases and controls differed significantly in several characteristics that influence the risk of VTE, specifically greater body weight and a positive family history of VTE. We know that a twofold increased risk of VTE is uniformly reported, including the data from the WHI.<sup>1218,1219</sup> It is very likely that the French estimate is higher compared with the usual twofold increased risk because of confounding differences between their cases and controls. **It is worth noting again that in the WHI, the cases of venous thrombosis were concentrated in the first years of exposure, in the oldest and in the heaviest women in the study.**

The French case-control study found no increase in VTE risk associated with estrogen combined with progesterone or pregnane derivatives and an increase with norpregnane derivatives. The pregnane group includes synthetic progestins familiar to use such as medroxyprogesterone acetate, chlormadinone, and cyproterone. The norpregnanes (progesterone without the 19-carbon) included two progestins, nomegestrol acetate and promegestone, that are not used in the United States (nomegestrol acetate is the progestin in Uniplant, a single-rod implant contraceptive, and combined with estradiol in an oral contraceptive). But can we make the conclusion that the norpregnanes are thrombogenic? The confidence interval in the norpregnane group was very wide, again apparently not due to small numbers, but this makes this conclusion shaky and suspect. Similar results were reported from the E3N French prospective cohort study, with an increased risk of VTE of 1.7 (CI = 1.1–2.8) associated with current users of oral therapy (a hazard ratio more in keeping with the usual twofold increase reported in the literature) and no increase with transdermal estrogen.<sup>515</sup> Again, an increase was observed with norpregnane progestins, this time with tighter confidence intervals. In contrast, several other studies have demonstrated an increased VTE risk in women using medroxyprogesterone.<sup>1225</sup>

In the French studies, oral hormone users used almost exclusively estradiol in doses

that averaged 1.5 mg/day. Transdermal users most commonly used an estradiol dose of 50 µg or less daily. To legitimately compare oral and transdermal methods, one would have to be sure the two groups had similar blood levels, to account for the wide variation in metabolism and clearance among individuals. It is possible that the difference between the oral and transdermal groups represents differences in estrogen doses. Nevertheless, the French conclusions are supported by a very large case-control study (23,505 cases of VTE) using the U.K. General Practice Research Database.<sup>742</sup> The use of transdermal estrogen alone or combined with a progestin was not associated with an increase in VTE, compared with about a 1.5-fold increase with oral estrogen alone and oral estrogen-progestin.

A greater safety with transdermal administration of estrogen with regard to VTE makes some sense because of the known lesser impact on clotting proteins when the first-pass liver effect is avoided. This is supported by transdermal estrogen's almost negligible effect on APC resistance when compared with oral therapy.<sup>510,1226</sup> A randomized trial assessing the risk of recurrent VTE in women with a prior history of thrombosis being treated with an oral hormone regimen was canceled after 1 year when eight women in the treated group developed recurrent venous thrombosis compared with only one in the placebo group.<sup>1227</sup> The eight women were studied retrospectively, and six of the eight had an inherited susceptibility to venous thrombosis. The numbers were not large, but the results are a strong argument for the recommendations detailed in [Chapter 22](#). There is no argument that inherited abnormalities in the clotting scheme increase the risk for VTE. The evidence is mixed for arterial thrombosis, but most of the evidence fails to find an association between specific inherited defects (thrombophilia) and arterial thrombosis, although this is still unsettled.<sup>1228,1229,1230,1231</sup>

If a patient has a close family history (parent or sibling) or a previous episode of idiopathic thromboembolism, an evaluation to search for an underlying abnormality in the coagulation system is warranted before exposing the patient to exogenous hormone therapy. The following measurements are recommended, and abnormal results require consultation with a hematologist regarding prognosis and consideration for prophylactic treatment with an anticoagulant. The list of laboratory tests is long, and, because this is a dynamic and changing field, the best advice is to consult with a hematologist ([Table 17.14](#)). When a diagnosis of a hereditary thrombotic tendency is made, screening should be offered to other family members.

## **TABLE 17.14**

## Hypercoagulable Conditions

## Screening Test/s

Antithrombin III deficiency

Antithrombin III

Protein C deficiency

Protein C

Protein S deficiency

Protein S

Factor V Leiden mutation

Activated protein C resistance ratio

Prothrombin gene mutation

Prothrombin G mutation (DNA test)

Antiphospholipid syndrome

Hexagonal activated partial thromboplastin time

Anticardiolipin antibodies

Lupus anticoagulant

Beta2 glycoprotein antibodies

Hyperhomocysteinemia

Homocysteine level

Malignancy

Complete blood count (leukemias, lymphoma)

Fibrinogen

Other risk factors for thromboembolism that should be considered by clinicians include an acquired predisposition, such as the presence of lupus anticoagulant or malignancy, and obesity, immobility, or trauma. Varicose veins are not a risk factor unless they are very extensive, and, unlike arterial thrombosis, smoking either has no effect or at best is

a weak risk factor for VTE. Raloxifene (and tamoxifen) shares with estrogen an increased risk for VTE.<sup>655</sup> The size of the risk is comparable for all three drugs, about a twofold increase.

## Key Points: Hormone Therapy and VTE

- **Observational studies support the clinical choice of a transdermal method for women who are at higher risk for VTE and for whom menopausal HT is being considered due to failure of symptom benefit from nonhormonal strategies.**
- **Although existing data are overall reassuring regarding safety of progestin regimens commonly used in menopause hormone regimens, an absence of good data does not allow making any statements with confidence regarding an absence of thrombogenic risk for the various progestins. However, it may be prudent to consider transdermal E2 with micronized progesterone (in women with a uterus) in those deemed at risk for VTE until RCTs confirm/refute the safety of alternative progestogens.<sup>1225</sup> The clinician and patient can together consider a combination of hormone therapy (preferably transdermal administration) and chronic anticoagulation, in consultation with a hematologist.**
- **We recommend appropriate prophylactic anticoagulant treatment in hormone users anticipating immobility with hospitalization, especially if other risk factors (most notably, obesity) are present. Some patients may elect to discontinue hormone treatment 4 weeks prior to major surgery if extended immobility is to be expected, but this is an empiric, individual decision. Hormone therapy can be resumed when the patient is ambulatory.**



# BREAST CANCER AND POSTMENOPAUSAL HORMONE THERAPY

---

Women and clinicians are regularly reminded about the threat of breast cancer, in the media, by advertisements, and by the experience of a friend or family member fighting this disease. Breast cancer is a major focus in the health concerns and care for postmenopausal women because it has an increasing frequency with age. About 95% of all breast cancers and 97% of breast cancer deaths in the United States occur in women over age 40.<sup>1232</sup> Thus, there are good reasons why this medical condition is a prominent factor in clinical decision-making regarding postmenopausal hormone therapy.

The long-term use of postmenopausal hormone therapy has been challenged by data that have been interpreted to indicate that the risk of breast cancer is increased in hormone users. The debate and publicity over this issue have made decision-making very difficult for both patients and clinicians. **The most important unanswered question is whether postmenopausal hormone therapy initiates the growth of new breast cancers or whether the epidemiologic results reflect an impact on pre-existing tumors.**

## Biologic Plausibility

The most compelling reason to believe that long-term use of postmenopausal estrogen increases the risk of breast cancer is the inherent biologic plausibility. Factors known to increase a woman's exposure to estrogen are known to increase the risk of breast cancer; for example, there is a small decrease in risk with late menarche and a moderate increase in risk with late natural menopause.<sup>1233</sup> In premenopausal women who are overweight, the risk of breast cancer is lower compared with normal-weight individuals, and in postmenopausal women, excess weight is associated with either an unchanged or slightly increased risk.<sup>1234,1235,1236</sup> This is attributed to an increase in total and free estrogen levels in overweight postmenopausal women, in contrast to lower levels with increasing weight in premenopausal women. Postmenopausal obese women have later menopause, higher estrone production rates and higher free estradiol levels (lower SHBG), and a slightly greater risk for breast cancer.<sup>1237</sup> Greater bone density, believed to be a marker for estrogen exposure, is also associated with an increased risk of breast cancer.<sup>1238,1239,1240</sup>

Studies seeking a correlation between circulating levels of sex hormones and breast cancer have yielded conflicting results. In the Rancho Bernardo cohort, no relationship between estrogen, androgen, and SHBG levels and the incidence of breast cancer could be demonstrated.<sup>1241</sup> Using serum collected earlier in life, no differences in endogenous hormones could be detected in 51 women who subsequently developed breast cancer, including the various estrogens, progesterone, androstenedione, and even SHBG.<sup>1242</sup> On the other hand, in a very large prospective study in Italy, estradiol, testosterone, and SHBG levels were higher in postmenopausal women who subsequently developed breast cancer.<sup>1243</sup> In a British report, women who subsequently developed breast cancer had higher levels of estradiol.<sup>1244</sup> Two North American prospective studies also found higher levels of estrogen in women who subsequently developed breast cancer, and most impressively, an increasing risk of breast cancer correlated with increasing levels of free estradiol.<sup>1245,1246</sup> In another study, women who developed breast cancer displayed higher levels of nonbound, free estradiol and lower levels of SHBG.<sup>1247</sup> In the Nurses' Health Study, an association was reported between an increased risk of breast cancer and higher levels of estradiol, estrone, and DHEA-S, whereas no association could be demonstrated with the percent free or bioavailable levels of estradiol, androstenedione, testosterone, or DHEA.<sup>1248</sup> **The discrepancies among the various studies seeking a correlation between hormone blood levels and the risk of breast cancer reflect the fact that the differences are very small, and it is a struggle to achieve statistical significance.**

Overall, the biologic plausibility for an estrogen link with breast cancer is an

impressive argument. This argument is further strengthened by the proven benefit of reducing the incidence of breast cancer with the antiestrogen, tamoxifen. However, as we shall see, establishing a clinically real cause-and-effect relationship with epidemiologic data requires more than the rationale of biologic plausibility.

## Key Points: Postmenopausal Breast Cancer Risk

- **The risk of breast cancer is increased with increasing duration of lifelong exposure to estrogen.**
- **Postmenopausal women who are overweight have a slightly increased risk of breast cancer.**

# Results from Observational Studies

In the past decade, a large number of case-control and cohort studies indicated a slightly increased risk of breast cancer with postmenopausal hormone therapy. Overall, most of these studies indicated a greater risk associated with estrogen-progestin compared with unopposed estrogen treatment.<sup>1249,1250,1251,1252,1253,1254,1255,1256,1257,1258,1259,1260,1261,1262,1263,1264,1265</sup>

## A Reanalysis of the World's Literature

Prior to the publications from the WHI, the 1997 report of a reanalysis of the world's literature was the most referenced article on this subject. A team of epidemiologists invited all investigators who had previously studied the association of postmenopausal hormone use and the risk of breast cancer (51 studies) to submit their original data for a collaborative combined reanalysis, an undertaking more rigorous than a standard meta-analysis. This analysis reached the following conclusions<sup>1266</sup>:

- Ever users of postmenopausal hormones had an overall increased relative risk of breast cancer of 1.14.
- Current users for 5 or more years had a relative risk of 1.35 (CI = 1.21–1.49), and the risk increased with increasing duration of use.
- Current and recent users had evidence of having only localized disease (no metastatic disease) and ever users had less metastatic disease.
- There was no effect of a family history of breast cancer.

This was the first important indication that women with a positive family history of breast cancer do not have a further increase in risk with hormone therapy, a finding also reported in the WHI.<sup>1267</sup> There were two other notable conclusions: all of the increase in risk was localized disease, and women who used hormone therapy and developed breast cancer had better survival rates than nonusers; these observations have been repeatedly confirmed.

## The Million Women Study

The Million Women Study recruited 1,084,110 women between 1996 and 2001 from those invited by the U.K. National Health Service Breast Screening Programme to have screening mammography every 3 years (about half had ever used postmenopausal hormone therapy).<sup>1260</sup> The study data were recorded from questionnaires returned prior to the initial mammography, and the women were followed to determine cancer incidence and death. The study is noteworthy for its large numbers and adjustments for

the well-recognized factors associated with risk of breast cancer. No increase in risk of breast cancer was measured in past users of any hormone preparation, regardless of length of time since discontinuation, from less than 5 years to 10 or more years (with the exception of discontinuation in the year previous to diagnosis), and regardless of duration of use. Based on an average follow-up of 2.6 years (a very short exposure; indeed, the breast cancers were diagnosed on an average of 1.2 years after the study began), the relative risk for invasive breast cancer in current users of estrogen only was 1.30 (CI = 1.22–1.38) and, for current users of estrogen-progestin, 2.00 (CI = 1.91–2.09).

There are many criticisms of the Million Women Study. For example, the study reported a lower risk of breast cancer for perimenopausal and postmenopausal women compared with premenopausal women despite the well-established fact that breast cancer risk increases with aging. There were many differences comparing users and nonusers, requiring multiple adjustments. Hormone use or nonuse was established at entry and not changed during follow-up despite multiple crossovers in treatment among the women. Validation of the questionnaire data was claimed based on information obtained from only 570 women. Breast cancer mortality was assessed after an average of 4.1 years of follow-up, based on a total of 517 deaths; however, breast cancer was diagnosed very rapidly (an average of 1.2 years) and deaths occurred swiftly (within an average of 1.7 years). Current users and past users were compared with the never-users, and, although the risk of mortality was increased, it did not reach statistical significance (1.22; CI = 1.00–1.48). This finding was highlighted because it differed with a consistent story reported in the literature over a decade that hormone users had better survival rates. The Million Women Study calculated their risk of mortality by dividing deaths from breast cancer by the total number of users or nonusers. When the data are recalculated appropriately by dividing deaths from breast cancer by the total number of cases of breast cancer in the user and nonuser groups, the results agree with the literature—the risk of mortality was reduced about 27% in the hormone users.

## **The Danish Nurse Cohort**

The Danish Nurse Cohort of 10,874 women was established in 1993.<sup>1268</sup> The results reflected a variety of hormone products and regimens, and an increased hazard ratio for breast cancer was associated with hormone therapy (HR = 2.42; CI = 1.81–3.26), with a twofold increase in breast cancer mortality. Stated simply, hormone users had a greater mortality rate from breast cancer because they had more breast cancers. Even though the case fatality rate was better (more favorable prognosis), the increased incidence produced a net effect of an increase in mortality.

Danish case-control and cohort studies are noted for their ability to accurately

obtain information from the national registries. Nevertheless, there were important limitations to this study. The most glaring problem was that not all causes of death could be verified and a death in a woman with a diagnosis of breast cancer was assumed to be a breast cancer death. The authors state that this problem would be balanced by similar numbers in the user and nonuser groups, but this is an assumption. In this population of older women, one would expect deaths from other causes to outnumber deaths from breast cancer. This single assumption by the epidemiologists could have skewed the results.

In addition, the case fatality and breast cancer mortality calculations were adjusted only for age. The authors stated that a relatively small number of deaths precluded multiple adjusting. But there are so many factors that influence the risk of breast cancer, including age of menarche, age at menopause, age at first full-term pregnancy, parity and age at diagnosis, use of mammography, presence of benign breast disease (specifically with atypical hyperplasia), body size, and alcohol intake. How can we know that the results did not reflect an imbalance in some of these factors?

## **Hormone Therapy and Lobular Breast Cancer**

A population-based, case-control study adds to the previous reports from this Seattle group of epidemiologists focusing on the relationship between postmenopausal hormone therapy and the histologic subtype of breast cancer.<sup>1269</sup> The main conclusions are an increased risk of tumors of the lobular type or with a lobular component and an increase in the odds ratio that appeared with 3 or more years of use with combined estrogen-progestin therapy. Similar results were reported in Swedish and German case-control studies.<sup>1263,1270</sup>

It is a logical conclusion that the results reflect increasing proportions of hormonally sensitive tissue. Lobular tumors are characteristically estrogen receptor positive and more hormone sensitive. If hormone therapy is affecting pre-existing tumors, one would expect the hormonally sensitive lobular cancers to be detected earlier.

### **Key Points: Hormone Use and Breast Cancer**

- **Case-control and cohort studies have identified an increased risk of breast cancer associated with hormone therapy, greater with combined estrogen-progestin regimens.**
- **The incident cases of breast cancer associated with hormone therapy use are predominantly estrogen receptor–positive tumors, perhaps mostly tumors**

**with lobular tissue.**

- **An increased risk of breast cancer is predominantly observed only in current users and is detected relatively rapidly.**

# The Women's Health Initiative

The impression gained from the observational data concluding that exposure to estrogen-progestin was more harmful was reinforced when clinicians were confronted by the results in the prematurely stopped estrogen and progestin arm of the WHI.<sup>1271</sup> Invasive breast cancer was increased, 199 cases in the treated group and 150 in the placebo group (HR = 1.24; CI = 1.01–1.54). The absolute risk was four to six additional cancers per 10,000 women per year. The WHI performed subgroup analyses focusing on how prior hormone therapy use influenced the risk of breast cancer found in the estrogen-progestin trial arm.<sup>1272</sup> Prior hormone users totaled 4,311 participants (26%), with 42% reporting less than 2 years of use (17% used hormones 5–10 years previously and 26% more than 10 years before enrolling in the WHI study). Prior users had an increased hazard ratio compared to placebo (1.96; CI = 1.17–3.27) in contrast to no increase among never-users (1.02; CI = 0.77–1.36). The WHI concluded that this difference could reflect an increasing risk with cumulative exposure to hormone therapy.

Many of the factors associated with the risk of breast cancer were slightly but significantly more prevalent in the group of prior hormone users in the WHI, such as younger age, more education, lower body mass, more physical activity, smoking, alcohol use, vasomotor symptoms, and lower bone density. The overall risk of breast cancer in the treated estrogen-progestin group was the same as previously reported by the WHI (1.24; CI = 1.02–1.50).<sup>1271</sup> However, after adjusting for the multiple factors recognized to influence the risk of breast cancer, the hazard ratio was 1.20 and no longer statistically significant (CI = 0.94–1.53). The placebo group failed to demonstrate an age-related increase over the duration of the trial, and the treatment group and the placebo group differed in regard to breast cancer risk factors, forcing the investigators to perform multiple adjustments. Why did not the randomization of large numbers avoid this confounding problem? The strength of the WHI conclusion is limited by the fact that the participants in the treatment and placebo groups differed considerably.

The updated results in the second estrogen-only arm of the WHI, which too was prematurely stopped, failed to detect an increase in breast cancer risk associated with estrogen-alone use (RR = 0.80; 95% CI = 0.62–1.04).<sup>1273</sup> Indeed, the decreased risk of breast cancer in the CEE group reached statistical significance in the postintervention phase (HR = 0.77; 95% CI = 0.62–0.95).<sup>1274,1275</sup> In addition, there was a significantly lower mortality risk from breast cancer in the estrogen-treated group compared to placebo (HR = 0.37; 95% CI = 0.13–0.91).<sup>1275</sup> This striking difference between the two canceled arms led many to conclude that the results indicated an adverse effect of progestin exposure or, more bluntly, that there is no increase in risk with up to 5 years of



estrogen-only use in contrast to an increased risk with estrogen-progestin.

It cannot be emphasized too strongly that it is not appropriate to compare the two hormone treatment WHI trials and conclude that differences reflect the effects of progestin exposure. Even the WHI investigators cautioned clinicians to avoid comparing the two trial arms because the participants in the two arms differed considerably.<sup>1180</sup> In regard to breast cancer risk, women in the estrogen-only arm had a higher rate of previous exposure to hormones and longer durations of prior use. It is possible that earlier and greater use of hormone therapy before participation in the study identified those individuals with pre-existing tumors who were then excluded from participation, accounting for the lower incidence of breast cancer in the treated group. **The breast cancer results in the WHI do not allow us to answer the important question whether exposure to estrogen-progestin has a greater risk of breast cancer or whether preexisting tumors respond differently to the various hormone regimens, accounting for differences in epidemiologic reports. This will be addressed in detail later in the chapter.**

# BREAST CANCER RISK AND DURATION OF HORMONE USE

---

A cohort study assessed the risk of breast cancer in postmenopausal Finnish women using oral, transdermal, and vaginal estrogen-only or estrogen-progestin products containing either estradiol or estriol.<sup>1276,1277</sup> The use of estradiol for 5 or more years and the use of estrogen-progestin for 3 or more years were associated with a statistically significant increased risk. The risk was similar comparing oral and transdermal therapy. An increase was observed in both localized and metastatic diseases. A statistically significant increase was noted with carcinoma in situ.

Only 7% of Finnish postmenopausal women use hormone therapy for more than 5 years. This study reported an increase in breast cancer risk in this long-term user group of women. No increase in breast cancer risk was detected either in association with estriol given orally or with vaginal estrogen products; however, it is inappropriate to conclude that these formulations can be used without risk. To make this conclusion, users and nonusers of these formulations would have to be identical in terms of breast cancer risk factors and to be comparable in terms of bioequivalent blood levels of estrogen. Only then could a valid comparison be made. This study could not adjust for these factors.

The use of postmenopausal hormone therapy in Finland can be accurately recorded because all treatments must be prescribed and then paid for by the National Social Insurance Institution. However, the study is affected by an overwhelming problem: the results are questionable because of an inability to control for confounders. The risk was expressed as incidence ratios, calculated by dividing the observed number of cases by the numbers expected (based on the general statistics in Finland). Therefore, the study could not be controlled for confounders. Risk ratios less than 2.0 can easily be inaccurate because they can reflect confounding factors. It is well-demonstrated that hormone users differ when compared to nonusers in terms of recognized risk factors for breast cancer. The differences also include a greater prevalence of mammography among hormone users. A good example can be found in the report from the Nurses' Health Study that, like the cohort from Finland, indicated an increased risk of breast cancer with long-term users of estrogen only.<sup>1278</sup> The long-term users in the Nurses' Health Study had more bilateral salpingo-oophorectomies, more nulliparity, more benign breast disease, and greater alcohol consumption, and they were thinner—all factors that make a comparison of users to nonusers very difficult.

In order to minimize the problem of confounders, the Finnish report argued that “there are no socioeconomic differences between postmenopausal hormone therapy users and the general population in Finland,” citing a previous report. This statement is

not totally accurate. The previous report in 1999 was based on population surveys and measured only two things: length of education and rural versus urban living.<sup>1279</sup> A lack of educational differences was present in Finnish women under the age of 55, but older postmenopausal women had more years of education. In addition, there were regional differences at all ages, with the current use of hormone therapy being most common in the Helsinki area (especially among older women). Therefore, the 1999 study does not imply a lack of differences in hormone users in Finland, in fact, just the opposite. Age information is not provided in the reports on breast cancer, but the longer-term hormone users were probably an older group of women, and according to the 1999 Finnish report, they do differ when compared to the general population of Finland. Remember, this cohort study is not comparing users with nonusers. It compares users to general population statistics. Therefore, we cannot know whether the results of this study reflect long-term use of estrogen or whether the results reflect a greater prevalence of risk factors and mammography in the hormone-using group (see [Table 17.13](#)).

# Hormone Therapy and Breast Cancer Outcome

Long-term use of HT increases the risk of breast cancer, yet cause-and-effect mechanisms are unclear. In the WHI trials, estrogen plus progestin use showed increased risk, while use of estrogen alone did not result in added risk for breast cancer. This disparity in results of the two WHI hormone trials raised concerns that progestin may be the culprit in causing breast cancer in hormone-using menopausal women. Most of the studies that have examined breast cancer mortality rates of women who had used postmenopausal hormone therapy at the time of diagnosis have documented improved survival rates.<sup>1132,1143,1151,1280,1281,1282,1283,1284,1285,1286,1287,1288,1289</sup> Even a study that indicated a reduction in mammographic sensitivity also reported smaller, more differentiated tumors among the users compared with the nonusers.<sup>773</sup> Evidence indicates that hormone users develop smaller, better-differentiated (lower grade), and lower-stage tumors, evidence that is consistent with effects on preexisting tumors and that surveillance/detection bias is not the only explanation for better survival.<sup>1259,1288,1289,1290,1291,1292,1293,1294,1295,1296,1297,1298,1299,1300,1301,1302,1303,1304,1305,1306</sup>

Lower-grade tumors are present even when there is no difference in the prevalence of mammography comparing hormone users and nonusers or when the data are adjusted for the method of detection.<sup>1284,1286,1297,1307</sup> This is not a totally uniform story, in that at least one prospective study concluded that estrogen-progestin users had both lower and higher stage and grade tumors.<sup>1259</sup> However, nearly all reports indicate that more tumors in hormone users are detected by screening mammography, and when assessing outcomes in all cancers detected by mammography, hormone users have more ductal in situ tumors, more node-negative cancers, smaller tumors, and less invasive disease and, thus, better survival rates.<sup>1289,1302</sup>

In contrast, the WHI results in the estrogen-progestin arm indicated an earlier appearance of invasive, lymph node-positive tumors than previously reported in case-control and cohort studies. The WHI argued that the results (both the invasive breast cancers and the mammography findings) are consistent with stimulation of growth of established breast cancers (supported by no statistical difference in in situ tumors in the WHI trial) but at the same time a delay in diagnosis. This certainly challenges the idea that hormone users have better outcomes because of earlier detection. The WHI suggested that this disagreement could be because of a difference of mammography use in the observational studies. However, as pointed out, even studies that examine tumor characteristics and outcome in users and nonusers who have equally used mammography, lower-grade and lower-stage disease with a better outcome is identified in the users.<sup>1284,1286,1302</sup> In addition, a prospective cohort study found little impact of hormone use on mammography specificity.<sup>1308</sup>

Differing with many reports in the literature, the WHI concluded that their results suggested that invasive breast cancers diagnosed in women who use hormone therapy may have a worse prognosis, basing this conclusion on the differences observed in tumor size and spread of disease. As previously discussed, it is well-recognized that the participants in the WHI represent an older postmenopausal population (average age 63 and an average of about 12 years since menopause in the estrogen-progestin arm). This older population is more likely to have preexisting occult tumors that would become detectable quickly after hormonal stimulation. In addition, breast tissue in older postmenopausal women may respond differently to hormone stimulation than breast tissue in women close to their menopause. It is possible that the WHI results reflect this older population that might have occult tumors that are in fact larger and more prone to respond to hormonal stimulation than tumors in younger women.

There is another problem with the WHI data on tumor size and stage of disease. The WHI reported that estrogen-progestin users had slightly larger tumors (an average of 2 mm) and less localized disease. However, there are reasons, both apparent and not apparent, why the WHI data disagree with the great bulk of the literature. First, no nodes were examined in nearly 10% of the subjects who developed breast cancer; information was missing on node involvement in 4.0% of the treated group and 4.7% of the placebo group and on tumor size in 6.5% of the treated group and 6.0% of the placebo group. Because case numbers were not large, a change in a few cases could change the conclusions. Next, the WHI investigators assumed that tumors less than 1 cm in size with no node information should be classified as localized disease, and those greater than 1 cm in size were not staged. According to the U.S. SEER data, breast tumors 1 cm in diameter have a 20% incidence of positive nodes.<sup>1309</sup> Finally, there is a major problem that is hard to explain. The WHI conclusion of less localized disease in hormone users is based on, once again, a difference in the placebo group, a surprisingly low incidence of positive nodes. There is a linear relationship between tumor diameter and the percent of cases with positive nodes.<sup>1309</sup> The average tumor size in the placebo group was 1.5 cm, and according to U.S. data, this should give about a 25% incidence of positive nodes, not the 15.8% that was reported.<sup>1309,1310,1311,1312</sup> Why is the placebo group different? Whatever the reason, it influences the conclusion.

The WHI investigators reported health outcomes at 3 years after the estrogen-progestin arm of the clinical trial was terminated.<sup>1313</sup> This follow-up report included 15,730 participants who were followed from July 2002 to April 2005 (95% of randomized women). No increase in cardiovascular events, including venous thrombosis, in the women treated with estrogen-progestin was observed in the follow-up period. There were 79 cases of invasive breast cancer in the treated group in the follow-up period compared with 60 in the placebo group, a difference that gave a hazard ratio of 1.27, but it was not statistically significant. There was no difference in

cases of colorectal cancer or fractures and a nonsignificant decrease in endometrial cancer in the treated group. There was a greater rate of mortality in the treatment group in the follow-up period, but this difference was small and not statistically significant.

A strong case can be made that the epidemiologic data on breast cancer reflect an impact of hormone therapy on pre-existing tumors. This WHI follow-up report concluded that the trend of increasing breast cancer during the trial period did not extend into the follow-up period. This is the pattern one would expect if hormone therapy is causing earlier detection of pre-existing tumors only in current users. An adverse interpretation of the WHI follow-up report was based on a small and nonsignificant increase in mortality in the treated group, because of deaths from various cancers, but most prominently lung cancers (discussed later under the heading “Lung Cancer”).

## Key Points: Breast Cancer in Hormone Users

- **Lower grade and stage of disease account for the better survival rates in hormone users who develop breast cancer compared with nonusers.**
- **Hormone users who develop breast cancer usually have earlier detection of their tumors.**
- **The survival and detection results are consistent with an impact of hormone therapy on preexisting tumors.**

# The Impact of Hormone Therapy on Breast Density

An increase in mammographic breast density occurs at a greater rate in postmenopausal hormone users who develop mastalgia.<sup>1314</sup> According to the PEPI and WHI clinical trials, about 25–30% of women receiving combinations of estrogen and progestin develop breast tenderness.<sup>1314,1315</sup>

The subject of greatest clinical relevance, in our view, is the connection between breast tenderness and breast density and ultimately the impact on the risk of breast cancer. Although the increase in new-onset breast tenderness is associated with a greater increase in mammographic breast density compared with women who do not develop mastalgia, it is worth noting that one study asking whether hormone-induced changes in breast density increase the risk of breast cancer could find no evidence that this was so.<sup>1316</sup>

A report from the WHI concluded that new-onset breast tenderness in the canceled estrogen-progestin arm of the WHI was associated with an increased risk of breast cancer (HR = 1.48; CI = 1.08–2.03) when compared to women who did not develop mastalgia.<sup>1315</sup> The WHI report gave the impression that this linkage was of sufficient magnitude that it should be a major clinical concern, but there are reasons to place it in a different perspective.

The WHI compared the numbers for sensitivity, specificity, and positive predictive value with the Gail model, implying clinical worthiness by their similarity. However, the positive predictive value of new-onset mastalgia in the WHI was 2.7%, meaning that 97.3% of the women would be expected not to develop breast cancer. Furthermore, in the references cited by the WHI to buttress their use of the Gail model, one actually concluded that the Gail model is not particularly sensitive in identifying individuals at risk, and the other was a study of false-positive mammogram screening.<sup>1317,1318</sup> A positive predictive value of 2.7% is not clinically strong.

The WHI report appropriately acknowledges the increase in breast tenderness noted in some postmenopausal women treated with hormone therapy and the link between mastalgia and an increase in mammographic density; however, the WHI report discusses these subjects as if it has accepted that the hormone-induced increase in density is associated with an increased risk of breast cancer. Let's consider these issues.

Increased density impairs the detection of breast masses.<sup>1319</sup> A failure to detect masses because of high tissue density causes an increase in interval cancers (cancers that present between mammographic screenings; in other words, cancers diagnosed after a negative mammogram).<sup>1320</sup> Difficulties in reading high-density mammograms also

produce false-positive recalls (patients who are recalled for assessment and found not to have cancer). Being recalled for reassessment after an initial mammogram is a cause of significant psychological stress.<sup>1321</sup> In addition, at least 25% of the overall cost of mammographic screening in one U.S. program was attributed to investigations of false-positive readings.<sup>1318</sup>

These two problems, an increase in interval cancers (a decrease in mammographic sensitivity) and an increase in false-positive recalls (a decrease in mammographic specificity), are consistent with a possible decrease in the detection of cancer. Thus, the concern with dense breasts in postmenopausal women is a reduced quality of mammograms that would decrease the ability to detect early breast cancers.

Factors that are associated with greater breast density are nulliparity, older age at first birth, and current use of postmenopausal hormone therapy.<sup>1322</sup> Mammographically, dense breasts reflect a high proportion of stromal, ductal, and glandular tissue, associated with epithelial and stromal cell proliferation.<sup>1323</sup> The likelihood of dense breasts in hormone nonusers decreases with advancing age and increasing body weight as glandular tissue is replaced by fat.<sup>1322</sup> The link with nulliparity supports the contention that a full-term pregnancy early in life produces a change in structure in the breast that persists throughout life and is associated with resistance to proliferation.

Assessing the impact of breast density on the risk of breast cancer is complicated by two factors that produce heterogeneous data: (1) results from programs with biennial screening are less favorable when compared with annual screening and the available data are derived from both, and (2) results from recent years are better, reflecting improvements in technology. Nevertheless, high breast density (75% dense) on mammography in hormone nonusers is reported to be associated with a four- to sixfold increased risk of breast cancer.<sup>1324,1325,1326,1327</sup> **Although hormone therapy increases breast density in some women, it is not certain that the short-term increase in density with hormone therapy changes an individual's risk of breast cancer.**

More current users of hormone therapy have dense breasts than nonusers.<sup>1322,1328,1329,1330,1331</sup> In women younger than age 55, it is difficult to find any differences between hormone users and nonusers.<sup>629</sup> The impact is essentially limited to women older than age 55. The effect of hormone therapy on breast density occurs rapidly; thus, duration of use has no effect.<sup>629</sup> In the PEPI 3-year randomized trial, almost all increases occurred within the first year, with an increase in breast density observed in 8% of estrogen users and 19–24% of estrogen-progestin users and only 2% in the placebo group.<sup>1332</sup> The users of estrogen-progestin combined regimens had a greater risk of developing denser breasts compared with estrogen-alone treatment (7–13-fold greater in the PEPI trial with no differences observed comparing



medroxyprogesterone acetate to micronized progesterone).<sup>1332</sup> In the WHI, estrogen-progestin use increased density in an average of 6.0% of users in the first year, with attenuation in the second year to 4.9%.<sup>1333</sup> In careful studies, the daily, continuous, combined estrogen-progestin regimens have been reported to have a greater effect than sequential regimens, with an increase in density occurring within the first months of treatment and then maintained with no change.<sup>772,773,1334,1335,1336</sup>

**Therefore, hormone therapy increases breast density mainly in older postmenopausal women, more women respond to combined estrogen-progestin regimens (especially the daily, continuous programs), and the effect occurs within the first months of use and remains stable with no changes or some attenuation with increasing duration of use. However, this effect is only seen in at most about 25% of estrogen-progestin users, but usually around 10% of hormone users; indeed, it should be emphasized that most women do not respond in this fashion.**

Overall, studies have suggested that hormone users experience a decrease in mammographic sensitivity with a lesser impact on specificity (false-recall rates). However, the studies are based on small numbers of interval cancers, and it is uncertain how real or how large this effect is because of the difficulty in controlling for confounding factors (e.g., age, age at menopause, and time since menopause). If the effectiveness of breast cancer screening is reduced by postmenopausal hormone therapy, one would expect an adverse impact on breast cancer mortality. Instead, a study that indicated a reduction in mammographic sensitivity also reported smaller, more differentiated (grade I) tumors among the users compared with the nonusers,<sup>773</sup> and most of the studies that have examined the breast cancer mortality rates of women who had used postmenopausal hormone therapy, as reviewed above, have documented improved survival rates.

If breast density and breast cancer were a reflection only of hormone exposure, a strong preponderance of estrogen receptor–positive tumors would be expected in women with increased density. However, women with increased density demonstrated equal increases in risk for both estrogen receptor–positive and estrogen receptor–negative breast cancers, and one study found a preponderance of estrogen receptor–negative tumors in hormone users with dense breasts.<sup>1337,1338</sup> This suggests that other factors besides hormone exposure are involved in the relationship between density and breast cancer. For example, there is an association between breast density and family history of breast cancer, indicating an underlying genetic basis for both density and breast cancer.<sup>1339</sup> In a case-control study that assessed the relationship between hormone therapy and breast density, leaner women were more likely to increase their breast densities with hormone therapy, but there was no association between the response to hormones and family history, late age at first birth, or history of benign

breast disease; the study concluded that recognized risk factors influenced the response to hormone therapy only to a minor degree, suggesting again that unknown genetic factors are involved.<sup>1340</sup> In a study designed to correlate histologic findings in dense breast tissue, an increase in fibrous stroma and type 1 lobules was observed to be more prevalent in hormone users, but these changes were also present in nonhormone users, and overall, there was no statistically significant difference between histologic features and breast density in women undergoing mastectomy for breast cancer.<sup>1341</sup> If breast density in postmenopausal women were strictly related to the hormonal environment, a drastic reduction in the estrogen milieu of the breast should have a salutary impact on density. The MAP1 randomized trial evaluated the effect of letrozole treatment on breast density; no effect of aromatase inhibitor administration on breast density was observed despite 1 year of treatment.<sup>1342</sup>

The increase in breast density associated with postmenopausal hormone therapy appears in some studies to be a transient, reversible change, a change not consistent with a persistent effect on cellular proliferation. After discontinuing hormone therapy, it was reported that breast density rapidly decreases so that former users do not display an increase compared to never-users.<sup>1322,1331,1343,1344</sup> In a retrospective analysis, regression of hormone-induced abnormalities was found to occur within 2 weeks of cessation of treatment.<sup>1344</sup> Similar results were observed in a prospective study observing a reduction in density 3 weeks after stopping treatment.<sup>1345</sup> However, in a large randomized trial of 1,704 women aged 45–80, although suspension of hormone therapy for 1 or 2 months produced small but significant decreases in density, mammography recall rates of 10–12% were not affected.<sup>1346</sup> Furthermore, a nonrandomized before and after study (but of only 47 women) detected no significant changes in mammographic density after a 4-week cessation of hormone therapy.<sup>1347</sup> Besides discontinuing hormone therapy, another approach is to consider lower doses of hormone therapy; there is some evidence that low-dose treatment has little effect on breast density.<sup>1348</sup> The combination of the levonorgestrel intrauterine contraceptive device and estrogen therapy in postmenopausal women does not seem to increase breast density.<sup>1349,1350</sup>

## Key Points: Breast Density and Hormone Use

- **Some women develop an increase in breast density with the current use of postmenopausal hormone therapy, more often associated with continuous, combined use of estrogen-progestin regimens.**
- **The older a postmenopausal patient is, the greater the risk of developing an increase in breast density with hormone therapy.**

- **There is no strong evidence to indicate that new-onset tenderness or the increase in density with hormone therapy changes an individual's risk of breast cancer.**
- **The evidence to support a recommendation that hormone therapy should be discontinued for several weeks prior to mammography in women who have dense breasts is mixed, and the only randomized study found no impact of suspension of treatment on a mammography recall rate of about 10%. Nevertheless, this is a reasonable recommendation.**
- **In women who develop breast tenderness and/or an increase in density with postmenopausal hormone therapy, consider a dosage reduction of the administered hormones.**

# The Effect of Hormone Therapy on Mammographic Screening

The impact of screening mammography has been established by multiple randomized trials: about a 28% reduction in breast cancer mortality in women 50 years and older.<sup>1351</sup> At the same time, it is recognized that it is difficult for mammography to detect noncalcified masses, especially in dense breasts. This sensitivity problem has been improved by digital mammography, but not eliminated.

Does the hormonal effect on breast density impair mammographic screening? In other words, is there an increase in interval cancers and false-positive recalls in postmenopausal hormone users? In a review of seven studies, there were relatively few interval cancers in the user groups; nevertheless, six of the seven studies reported decreased mammographic sensitivity in hormone users with a small increase in interval cancers in users compared with nonusers.<sup>1352</sup> Excluding women under age 50, the relative risk for an interval cancer was summarized as 1.7 (CI = 1.2–2.4). American, Scottish, and Australian studies have indicated a 5–20% decrease in mammographic sensitivity in hormone users who have dense breasts.<sup>1353,1354,1355,1356</sup> A Finnish study concluded that women with the densest breasts, and using hormones, had the highest relative risk of breast cancer, but this conclusion was based on only four cases of cancer in women with dense breasts.<sup>1357</sup>

The risk of false-positive recall (mammographic specificity) was investigated in five studies.<sup>1353,1357,1358,1359,1360</sup> The rate of false-positive recall in nonusers ranged from 2.1% in the United Kingdom to as high as 14.7% in an American program; four of the five studies found a slight increase in the risk of false-positive recalls in hormone users. In a French study, mammographic sensitivity was reduced from 92% to 71% in users because of an incidence of interval cancers that was 3.5 times that of nonusers within the first year of the initial exam and 1.7 times greater during the following 2 years.<sup>1358</sup> Most of the hormone users were on combined estrogen-progestin regimens. The false-positive recall rate was only slightly higher, 3.3% in users and 2.8% in nonusers. A prospective study of screening mammograms from Massachusetts General Hospital concluded that recall rates were essentially the same comparing hormone users and nonusers and that hormone therapy rarely causes a diagnostic dilemma.<sup>1359</sup> However, in New Hampshire, increased breast density and use of hormone therapy independently increased the need for supplemental imaging.<sup>1360</sup>

Treatment with either estrogen alone or estrogen-progestin in the WHI was associated with more abnormal mammograms compared with placebo.<sup>1274,1361</sup> The difference was about 12% with estrogen-progestin and 8% with estrogen alone, but

remember the characteristics of the participants differed in the two arms of the clinical trial. Nevertheless, the higher prevalence with estrogen-progestin is consistent with the other studies in the literature. Overall, the studies have suggested a decrease in mammographic sensitivity with a small impact on specificity (false-recall rates).

## **Adding Ultrasound to Mammography**

The American College of Radiology conducted a prospective, multicenter, randomized trial in 21 centers in the United States, with 2,725 women, designed to validate the performance of screening ultrasound in conjunction with mammography in women with dense breasts and at high risk for breast cancer.<sup>1362</sup> Each patient underwent mammography and ultrasound in a randomized sequence. Forty cases of cancer were diagnosed, 12 on ultrasound alone, 12 on mammography alone, 8 suspicious with both techniques, and 8 with negative exams. Adding ultrasound yielded an additional 4.2 cancers per 1,000 high-risk women. The false-positive rate for mammography alone was 4.4%, for ultrasound alone 8.1%, and for combined mammography plus ultrasound 10.4%. **Thus, adding ultrasound to mammography screening in high-risk women with dense breasts improved the sensitivity of screening, but increased the rate of false-positive examinations. Breast cancer mortality was not an endpoint in this trial, but the fact that the cancers detected by ultrasound are usually asymptomatic, node-negative, and not detected by mammography should yield a reduction in mortality.**

Ultrasound screening can detect cancers not seen on mammography and its performance is not affected by dense breast tissue. Adding ultrasound to a screening program seems straightforward, but its impact on mortality reduction has not been measured in a large trial. In the single center studies of screening ultrasound that have been published, cancers have been found only by ultrasound, and most are small, early-stage tumors. An Italian multicenter study reported that 29 cancers were found by ultrasound in 6,449 women with dense breasts and negative mammograms.<sup>1363</sup>

The problem with all screening methods is a substantial rate of false positives. In the American study, 91.4% of suspicious ultrasound findings were benign.<sup>1362</sup> The positive predictive value for ultrasound was only 8.6%, but the value for mammography was 14.7%. The crucial question is how many false positives are worth the gain in additional cancer diagnoses. In the American study, the gain was an additional 29% (the number of cancers detected only by ultrasound). In women with elevated risks, this seems worthwhile.

**Combining MRI with mammography yields a very high sensitivity, and this is now recommended for women at very high risk for breast cancer.** Breast MRI is the most sensitive technique, but it is very expensive, requires the intravenous injection of

contrast, and isn't always tolerated by patients. Ultrasound has the advantage of being less expensive, easily tolerated, and widely available. Thus, the combination of ultrasound and mammography seems best for women of intermediate risk. Ultrasound has a disadvantage of not detecting ductal carcinoma in situ, which is detected by mammography and MRI.

In general, supplemental screening for dense breasts (either ultrasound or MRI) will identify more breast cancers (invasive cancers), but it may come at the cost of increased false-positive rates and biopsies.<sup>1364</sup> What is not known however is if cancers identified from ultrasound and MRI have improved outcomes and reduced mortality.<sup>1364</sup> **Further research studies are clearly needed.**

## Key Points: Mammography Screening

- **There is sufficient evidence to support utilizing more than one screening technique (mammography, ultrasound and MRI) for high risk patients defined as a combination of factors that produces a threefold increase in risk), especially in women with radiographically dense breast tissue. Thus far, over 90% of cancers detected only on ultrasound have been in women with dense breasts. Therefore, it seems advisable to add ultrasonography to mammography for hormone users who develop dense breasts, and the density persists despite a short period without hormone therapy. In addition, digital screening mammography is superior to conventional film screening for women with dense breasts.**<sup>1365</sup>
- **Hormone users who develop an increase in breast density have a small decrease in mammography sensitivity and an increase in false recalls. An adverse impact of this increase in breast density is not apparent in breast cancer mortality statistics in hormone users. Digital mammography is preferred for women with dense breasts.**
- **Ultrasonography should be added to mammography screening in hormone users who develop dense breasts with no regression after a short period without hormone treatment.**

# The Effect of Progestins in Combined Regimens

Recent studies support the conclusion that the relative risk of breast cancer is higher in users of combinations of estrogen and progestin. The effect is confined to estrogen receptor–positive, progesterone receptor-positive (ER+/PR+) tumors, mainly lobular cancers. **What if this conclusion reflects early detection of better-differentiated tumors, a consequence of a favorable response of pre-existing tumors to estrogen-progestin exposure?**

Almost every study that has reported an increase in breast cancer risk with postmenopausal hormone therapy has found the increase within a few years. Remember that although the doubling time of breast cancer is variable, in general, a tumor doubles in size every 100 days. Thus, it takes a single malignant cell approximately 7 years to become detectable by mammography and 10 years to grow to a clinically detectable 1-cm mass.<sup>1366</sup> The rapid finding of an increased risk within a few years of exposure to hormone therapy suggests that the epidemiologic studies are detecting preexisting tumors.

Older studies on the hormone receptor content in breast cancers diagnosed in hormone users were limited by small numbers. Furthermore, recent studies examining receptor status are likely to be more accurate in that receptor status assays have improved. In the Nurses' Health Study, the use of postmenopausal hormone therapy has been associated with a significant increase in ER+/PR+ breast cancer, but not receptor-negative disease.<sup>1367</sup> This relationship, greatest in lean women, was stronger and observed sooner with the use of estrogen-progestin, a significant increase with 5 or fewer years of combined use and no increase with 5 or fewer years of the use of estrogen alone. In a cohort of women from the area of Lund, Sweden, an increased risk of breast cancer was reported only in users of continuous combined estrogen-progestin, and this increase was observed within 2 years of use.<sup>1368</sup> Other epidemiologic studies have reported a similar greater risk in current users of continuous, combined estrogen-progestin, concentrated in estrogen receptor–positive disease.<sup>1255,1258,1261,1369,1370</sup> Indeed, use of hormone therapy is the greatest predictor of estrogen receptor–positive disease.<sup>1371</sup> In a retrospective study in the Northern California Kaiser program, only the current use of combined estrogen and progestin increased the odds of estrogen receptor–positive tumors.<sup>1372</sup>

E3N is a French prospective cohort study initiated in 1990, which concluded that it would be preferable to use progesterone or dydrogesterone because estrogen use with these two progestins was not associated with an increase in the relative risk of invasive breast cancer.<sup>1373,1374</sup> For any given progestin, the route of administration of estrogen (oral or transdermal) had no effect on relative risk. A statistically significant increase in

relative risk was associated with estrogen alone (RR = 1.29; CI = 1.02–1.65) and with progestins other than progesterone or dydrogesterone (RR = 1.69; CI = 1.50–1.91). The increased relative risks seemed to rapidly dissipate after discontinuation of treatment; although this analysis was initially limited by small numbers, it was confirmed in a later follow-up.<sup>1375</sup>

The French study argued that their results indicate that the “natural” progestins are safer than “synthetic” progestins. But to accurately differentiate among various agents, one would have to be certain that the doses administered represented bioequivalent doses in terms of target tissue impact, something that would be difficult to do. Let’s focus on the rapidity at which cases of breast cancer were identified. The use of estrogen combined with “other progestins” had an increased relative risk even with less than 2 years of exposure (RR = 1.37; CI = 1.07–1.72). In their earlier report, an increased relative risk was even apparent with less than 1 year of exposure of estrogen combined with synthetic progestins.<sup>1373</sup> **The results in the French study could be due to earlier detection of pre-existing tumors, an effect accelerated by specific progestins with greater potency.**

A follow-up report from the French study indicated that the increased risk of breast cancer was evident only in women with recent use of hormone therapy and not in past users.<sup>1375</sup> Furthermore, the risk with short-term use was confined to hormone use with synthetic progestins for 2 or fewer years in the 3-year period immediately following menopause. With longer duration of hormone use, the risk was apparent even in those who initiated treatment years after the menopause. The logical conclusion is that this striking finding with short-term use early in the postmenopausal years reflects an impact of hormone therapy on pre-existing tumors.

Molecular biology studies provide support for a favorable effect of estrogen-progestin exposure. In vitro studies using microarray analysis have profiled the gene network both up- and down-regulated by estrogen.<sup>1376</sup> Genes that are up-regulated by estrogen are down-regulated by estrogen-progestin treatment.<sup>1377</sup> Comparing hormone users and nonusers, 276 genes were activated by hormone exposure (11 of the 13 women used estrogen-progestin and 2 used estrogen alone). All patients in this cluster were free of recurrence 5 years after diagnosis. In a cohort of 131 women, those patients exhibiting the gene profile associated with estrogen-progestin exposure preferentially benefited from tamoxifen treatment.<sup>1377</sup> This Swedish study found that estrogen-progestin use altered the gene expression profile only in estrogen receptor-positive cancers. Among the genes regulated, many were involved in either DNA repair or cell cycle regulation. For example, the p63 gene, involved in tumor differentiation, was overexpressed in estrogen-progestin users. Previous reports have found this gene to be expressed in normal tissue, partially expressed in ductal hyperplasia, and not



expressed in invasive cancers.<sup>1378</sup>

It is well recognized that early pregnancy produces a mammary gland that is resistant to carcinogenesis. In rodents, this is accomplished by treatment with estrogen plus a progestin. The refractory phenotype that is produced is associated with progestin-induced changes in gene expression involved in cell proliferation.<sup>1379</sup>

The progesterone receptor is induced by estrogens at the transcriptional level and decreased by progestins at both the transcriptional and translational levels (probably through receptor phosphorylation).<sup>1380</sup> The progesterone receptor has two major isoforms, designated the A and B receptors.<sup>1381</sup> The two forms are expressed by a single gene, a consequence of transcription from distinctly different promoters, in a complex system of transcription regulation.<sup>1382</sup> Progestational agents can elicit a variety of responses determined by target tissue production and activity of the two receptor forms with dimerization as AA and BB (homodimers) or AB (heterodimer).

PR-A and PR-B are expressed in varying amounts in breast cancer and endometrial cancer cell lines. Studies indicate that the two receptors can be regulated independently; for example, the relative levels differ in endometrium during the menstrual cycle.<sup>1383</sup> Tissue specificity with the progesterone receptor is influenced by which receptor and which dimer is active, and in addition, the transcriptional activities of PR-A and PR-B depend on target cell differences, especially in promoter context. In most cells, PR-B is the positive regulator of progesterone-responsive genes, and PR-A inhibits PR-B activity. Thus, repression of human estrogen receptor transcriptional activity (as well as glucocorticoid, mineralocorticoid, and androgen transcription) is dependent on the expression of PR-A.<sup>1384,1385</sup> The PR-A and PR-B progesterone receptors have different molecular functions, affecting different genes, and, therefore, target tissue response to progesterone will be influenced by the differential expression of each receptor and the ratio of their concentrations, as well as the target tissue context of adaptor proteins.<sup>1386,1387</sup>

**PR-A–positive breast cells exhibit more aggressive growth, and PR-A isoforms are dominant in the absence of progesterone.** Even without its ligand, PR-A can exert gene regulation in estrogen receptor–positive breast cell lines.<sup>1388</sup> In the absence of progesterone, PR-A up-regulates genes known to be associated with invasion and poor prognosis, including those genes that provide resistance to apoptosis. In the presence of progesterone, PR-B is a stronger regulator of gene transcription. The breasts of normal women express equal amounts of PR-A and PR-B.

PR-A excess and breast cancer are linked. Estrogen receptor–positive tumors with a higher rate of recurrence are rich in the PR-A isoform.<sup>1388</sup> As breast cancers become less differentiated, metastatic tumors become dominated either by PR-A or PR-B. PR-

A-rich tumors with a low PR-A:PR-B ratio do poorly and respond less well to tamoxifen.<sup>1389</sup> PR-A excess is also present in breast tissue from women with the BRCA mutations.<sup>1390</sup>

Thus, progesterone receptors are not just passive markers of estrogen activity. ER+/PR+ tumors are well differentiated and have better outcomes. In the absence of progesterone, the unliganded PR-A can adversely influence the cell biology of estrogen receptor-positive tumors. Cells rich in PR-A are more likely to be invasive, poorly differentiated, and aggressive. In monkeys, the breast levels of PR-A were unchanged after 3 years of treatment with conjugated estrogens alone.<sup>1391</sup> Treatment with conjugated estrogens and medroxyprogesterone acetate produced a decline in PR-A levels, producing a 10-fold beneficial change in the PR-A:PR-B ratio. It is possible that the exposure of an estrogen receptor-positive tumor to estrogen-progestin treatment can prevent an unfavorable PR-A:PR-B ratio, promoting the beneficial actions of PR-B. In addition, progestins may activate androgen receptors, a factor that has been demonstrated to inhibit growth and cause apoptosis in breast cancer cells.<sup>1392,1393</sup>

In a series of in vitro experiments, estradiol and its catechol metabolites induced neoplastic transformation in human breast epithelial cells.<sup>1394</sup> This, of course, would be consistent with a genomic impact of estrogen that initiates breast cancer, an effect earlier than a promoting influence on already-established cancers. However, it is difficult to transfer in vitro effects on cell lines to the in vivo situation, and this is especially true with breast tissue that is bathed in a complicated and large collection of stimulating and inhibiting substances. Furthermore, the cells in the in vitro experiments were negative for both estrogen and progesterone receptors. These receptor-negative malignant cells may well be something different than the receptor-positive tumors associated with postmenopausal hormone therapy.

Favorable effects of progestin exposure are reflected in the studies of the association between endogenous hormone levels and the risk of breast cancer. A pooled analysis of nine prospective studies of postmenopausal women concluded that the risk of breast cancer increases with increasing concentrations of all endogenous estrogens and androgens, including estradiol, estrone, estrone sulfate, androstenedione, DHEA, DHEA-S, and testosterone.<sup>1395</sup> The overall increase in breast cancer risk was about twofold comparing the lowest endogenous levels in postmenopausal women with the highest levels. Women who ultimately develop breast cancer do not have different blood levels of progesterone.<sup>1242</sup> Postmenopausal women who are overweight have an increased risk of breast cancer, and an analysis that adjusted for the increase in circulating estrogens associated with obesity concluded that the increasing risk with increasing body weight is the result of the increase in estrogens.<sup>1396</sup>

In contrast to the endometrium, epithelial cell proliferation in the normal breast and

in estrogen receptor–positive tumors reaches its peak during the progesterone-dominant luteal phase of the menstrual cycle.<sup>1368,1397,1398,1399</sup> This observation has been the driving force behind the argument that progesterone (progestins) is the major hormonal mitogen in the breast. However, studies do not support a major role for an adverse progestational influence. In animal models, it is estrogen that is the major inducer of proliferation and not progesterone. Indeed, evidence indicates that with increasing duration of exposure, progesterone can limit breast epithelial growth as it does with endometrial epithelium.<sup>1400,1401,1402</sup> In vitro studies of normal breast epithelial cells reveal that progestins inhibit proliferation.<sup>1403</sup> The story with human breast tissue specimens removed after the patients were treated with estradiol and progestin is more confusing, indicating on one hand that progestins inhibit in vivo estradiol-induced proliferation<sup>1400,1402,1404</sup> and, on the other hand, markers of epithelial and stromal cell proliferation were higher in women being treated with estrogen-progestin.<sup>627,1405</sup> Nevertheless, progestins have been demonstrated to decrease antiapoptotic protein expression,<sup>1406</sup> and apoptosis in breast tissue is higher in the luteal phase than in the follicular phase.<sup>1407</sup> Conversely, research comparing human breast cancer cell lines to noncancerous cells has demonstrated that progestogens differentially affect breast cell proliferative activity.<sup>1408</sup> A study by Courtin et al. analyzed the effects of estradiol (E2) alone, E2 + progesterone (P4), and E2 + medroxyprogesterone acetate (MPA) on cellular proliferation and apoptosis in breast cancer cells, as well as normal human breast cells.<sup>1409</sup> Treatment with E2 alone in all cell types resulted in increased cell proliferation. In normal human breast cells, the addition of P4 blocked estradiol's proliferative effect and also resulted in an increased number of apoptotic cells. When normal cells were treated with E2 + MPA, however, there was little effect on cellular proliferation, and the number of apoptotic cells was decreased. In MCF-7 and T47-D breast cancer cell lines, MPA did not induce cellular proliferation and neither MPA nor P4 affected apoptosis in these cells. Microarray studies revealed induction of different sets of genes in hormonally treated cells, compared to control cells. E2 + MPA modified genes in a distinctly different pattern from E2 + P4. In a study by Sweeney et al., it was found that MPA combined with E2 stimulated proliferation in long-term estrogen-deprived MCF-7 (MCF-7:5C) cells, while E2 alone resulted in cell death.<sup>1410</sup> Additional support for progestogens' role in breast cancer comes from studies analyzing MPA's effects on estrogen-metabolizing enzymes in breast cancer cells. Using T47-D and MCF-7 cells, it was demonstrated that E2 + MPA increased the expression of estrogen-activating enzymes but did not increase expression of estrogen-inactivating enzymes.<sup>1411</sup> The increase was greater than cells treated with E2 alone. Although there was an increase in estrogen-activating enzymes, there was no associated increase in cell proliferation. It is important to note, however, that locally increased estrogen levels can be seen in the breast cancer cell milieu, and this high-estrogen environment facilitates

cancer cell growth.<sup>1411</sup> Thus, MPA may exert its carcinogenic effect via induction of a local state of estrogen excess. However, as mentioned earlier, these in vitro models must be interpreted with caution, as what happens in vivo is influenced by many other factors.

In the postmenopausal monkey model, greater breast cell proliferation was observed after 30 months of treatment with estrogen-progestin compared with estrogen alone.<sup>1412</sup> In this same model, the administration of progesterone produced no differences in proliferation markers, but adding medroxyprogesterone acetate to estrogen increased breast proliferation by about 30% compared with placebo.<sup>1413,1414</sup> However, in this 2-month study, the administration of progesterone inexplicably lowered the blood levels of estradiol and estrone by 30–50%, in contrast to no effect with medroxyprogesterone acetate. Thus, the tissue results may reflect estrogen differences, not progestin differences. Nevertheless, the monkey experiments do not detect a beneficial effect of medroxyprogesterone acetate; a 2-year monkey study recorded lower levels of p53, a tumor suppressor gene, and lower levels of caspase-3, an enzyme involved in apoptosis.<sup>1415</sup> Given the marked similarities in macaques to human gene coding sequences, this primate serves as a more reliable model for studying the effects of menopausal hormone therapy on breast cancer acquisition.

A prospective study of premenopausal women in Italy found that higher progesterone levels in the luteal phase were associated with a reduction in breast cancer risk.<sup>1416</sup> However, a nested case-control analysis based on the Nurses' Health Study could find no influence of progesterone levels on breast cancer risk.<sup>1417</sup> In this study, women with the highest levels of total and free estradiol in the early follicular phase had about a twofold increase in breast cancer risk, predominantly ER+/PR+ tumors, and a similar increase in risk was associated with higher levels of total and free testosterone and androstenedione. There was no association with luteal estradiol levels, and the authors speculated that this is because early follicular phase levels reflect nonovarian target tissue levels and also that progesterone down-regulation of estrogen receptors may occur in the breast during the luteal phase.

Although it is not a uniform story, it is possible that favorable breast tissue effects of progestins translate into better differentiation and earlier detection of pre-existing tumors. Supporting data can be found in two important American studies. A retrospective cohort study in the Southern California Kaiser program found a reduction in breast cancer case mortality that was significant only among women with breast cancer who were users of estrogen-progestin, not with estrogen alone.<sup>1418</sup> An increase in lower-grade, lower-stage, estrogen receptor-positive cancers was found only in current users of estrogen-progestin in a study remarkable for its size, 374,465 women screened in six U.S. mammography centers.<sup>1259</sup> These data are consistent with a

beneficial effect of estrogen-progestin treatment.

Breast cancer mortality was recorded in the Collaborative Breast Cancer Study Cohort, a prospective cohort of 12,269 postmenopausal women from Wisconsin, Massachusetts, and New Hampshire.<sup>1419</sup> Women were followed for an average of 10.3 years after breast cancer diagnosis. After adjusting for BMI, smoking, and history of mammography screening, compared with nonusers, mortality from breast cancer was lower among current users of estrogen-progestin and an even greater effect, a 40% reduction, with 5 or more years of use. These are striking data. The strength of the study is the large size of the cohort. Indeed, this is the strongest evidence thus far published that the use of estrogen-progestin is associated with the development of less aggressive breast cancers. Even in studies that adjusted for the prevalence of mammography screening, breast cancers in hormone users were smaller, had fewer positive axillary lymph nodes, and were of lower-grade disease.

**The following evidence supports a beneficial impact of progestins on preexisting tumors:**

- **An increase in estrogen receptor–positive tumors is seen sooner with estrogen-progestin treatment, and greater risk is observed with continuous, daily estrogen-progestin use.**
- **Genes up-regulated by estrogen are down-regulated by estrogen-progestin therapy.**
- **Genes that are activated by estrogen-progestin are involved in DNA repair and cell cycle regulation.**
- **Progestins decrease breast tissue levels of PR-A, causing a beneficial change in the PR-A:PR-B ratio that is associated with better differentiation and outcome.**
- **A reduction in breast cancer case mortality has been reported with estrogen-progestin use, and not with estrogen alone.**

# Prevalence of Breast Cancer and Hormone Therapy

Multiple reports have documented a U.S. decline in breast cancer incidence that paralleled the decrease in use of postmenopausal hormone therapy that followed the publications from the WHI.<sup>1420,1421,1422,1423</sup> A similar decline was documented in France, Scotland, Switzerland, and Australia.<sup>1424,1425,1426,1427</sup> The decline was partially influenced by a decrease in screening mammography in the United States, but the correlation with hormone use exists even when the examined population includes only women screened with mammography. A similar pattern was evident in the WHI in the years following the cancellation of the estrogen-progestin arm as well as among the women in the observational arm, despite no change in the frequency of mammography in the WHI population.<sup>1428</sup>

This decrease in prevalence is consistent with the uniform findings in case-control and cohort studies of an increase in breast cancer risk only in current users, with a rapid reduction after cessation of treatment. An impact on existing tumors is supported by the other side of the coin, apparent in breast cancer statistics derived from the area around Geneva, Switzerland. Beginning in 1997, the peak breast cancer incidence in the Geneva area moved to a younger group of women (ages 60–64), with an increase occurring only in stage I and stage II disease with estrogen receptor–positive tumors in hormone users.<sup>1429</sup>

A median 8-year follow-up from the WHI was an anticipated postintervention follow-up report from the canceled arms of the WHI.<sup>1313,1430</sup> The trend of increasing breast cancer during the trial period did not extend into the follow-up period. Thus, it is very likely that the WHI results agree with the national data, and furthermore, the absence of a trend for increasing cases of breast cancer is the pattern one would expect if hormone therapy is causing earlier detection of preexisting tumors in current users. This agreement with national data was confirmed when the prevalence of breast cancer in the estrogen-progestin arm and the observational arm was reported by the WHI, indicating a marked decline after cancellation of the randomized trial.<sup>1428</sup>

The national decline in prevalence and the WHI results are both consistent with an impact of hormone therapy on preexisting tumors. If hormone therapy is affecting preexisting tumors, one would expect small, undetectable tumors to stop changing (at least temporarily) when women discontinue hormone therapy. This response would be consistent with the effects being reported, a decrease in estrogen receptor–positive tumors in younger postmenopausal women. The data most likely primarily reflect existing cancers just below the detection limit in 2002 that slowed or stopped their

growing.

The choice of estrogen used in the estrogen-alone arm of the WHI (CE) has been suggested to explain the favorable effects seen on the breast. The CE formulation contains a mixture of multiple estrogens, and each estrogen type not only preferentially binds the two estrogen receptors (ER-alpha and ER-beta), but may also exert differential actions depending on the target tissue.<sup>1431,1432</sup> In studying the effects of 11 equine estrogens (in CE preparations) on the transcriptional activity of ER-alpha and ER-beta, it was found that many of the equine estrogens preferentially bind ER-beta; ER-beta activation can inhibit ER-alpha activity on cell proliferation.<sup>1433,1434,1435</sup> The potential SERM-like properties of CE have also been demonstrated in breast cancer cells treated with CE and estradiol, where CE and estradiol were noted to have distinct effects on gene expression.<sup>1436</sup> Furthermore, it has been demonstrated that several estrogenic compounds in CE act as partial estrogen agonists; thus, like SERMs, the differences in binding and downstream cell signaling may afford CE with specific tissue manifestations that are unlike estradiol's purely stimulatory effects (i.e., manifestation of ER antagonistic effects).<sup>1436,1437</sup> This inhibition induced by equine estrogens may in part explain the decreased risk of breast cancer in the WHI estrogen-alone study; however, additional research is needed before definitive conclusions can be made. Lastly, the SERM BZA paired with a CE may further allow for favorable effects on breast tissue; BZA/CE also has the added benefit of avoiding a progestin.<sup>1438</sup>

## Key Points: Breast cancer prevalence and hormone use

- **A decrease in breast cancer prevalence paralleled the decrease in hormone use following the publicity generated by the WHI publications.**
- **The decrease in prevalence is consistent with the removal of hormonal effects on small undetectable tumors.**

# Hormone Therapy and the BRCA Mutations

Women with either BRCA1 or BRCA2 germline mutations are advised to undergo bilateral prophylactic oophorectomy after completion of childbearing because of a high lifetime risk (approximately 90%) for developing breast or ovarian cancer. This surgery reduces the risk of ovarian cancer by about 90% and the risk of breast cancer by about 50%. These relatively young women must consider the postoperative consequences of surgical menopause in their decision-making. In a cohort of 462 women with BRCA1/2 mutations from 13 medical centers in North America and Europe, the incidence of breast cancer was compared in 155 of the women who had undergone bilateral prophylactic oophorectomy with 307 women who did not have the operation.<sup>1439</sup> The women who had oophorectomy had a 60% reduction in the risk of developing breast cancer. Hormone therapy of any type did not alter the reduction in breast cancer experienced by the women undergoing oophorectomy. Thus, short-term use (several years) of hormone therapy did not have an adverse effect on the beneficial reduction in breast cancer risk following prophylactic oophorectomy. In a later follow-up of this group of women, 93 (60%) of the women who underwent oophorectomy used hormone therapy.<sup>1440</sup> The average length of follow-up was 2.6 years (more than 5 years in 16%) in the surgically treated group and 4.1 years (more than 5 years in 33%) in the nonoophorectomized group. There was no hint of a difference in breast cancer reduction comparing hormone users and nonusers. The findings were similar in 34 women who used a combination of estrogen and progestin, but the power of this finding was limited by the small number in this category.

A case-control study of 472 postmenopausal women with a BRCA1 mutation found that women who used hormone therapy after prophylactic oophorectomy, either estrogen only or combined estrogen-progestin, not only did not have an increased risk of breast cancer, but hormone use was actually associated with a decreased risk.<sup>1441</sup> The findings were the same regardless of duration of use or current or past use. The conclusion is encouraging, but limited by the fact that 68% of the tumors in the study were estrogen receptor–negative, making the estrogen receptor–positive tumors (that are more likely to be influenced by hormone use) relatively small in number.

Women who are BRCA carriers face difficult decisions. **The experience thus far indicates that hormone therapy can be used safely for several years.** Continuing follow-up of these patients may extend this period of safety even longer. A TSEC (CE paired with a SERM BZA) may be particularly suitable HT option in this population given its efficacy for symptom control and skeletal benefit while having neutral effects on the breast and potential of BZA for blockade of breast cancer cell proliferation as has been demonstrated in vitro.<sup>673,1436,1438</sup> However, future studies are needed to establish both safety and efficacy of this newer class of menopausal hormonal regimen



in breast cancer survivors as well as those who are at risk for breast cancer, such as BRCA1/2 carriers.

Prophylactic oophorectomy in women with BRCA mutations reduces the risk of breast cancer by about 50%. Thus far, hormone use after prophylactic oophorectomy has not diminished the beneficial reduction in breast cancer risk.

# Summary: Postmenopausal Hormone Therapy and Breast Cancer

## Key Points

- The WHI agrees with case-control and cohort studies indicating that current use of hormone therapy has a slightly increased risk of breast cancer.
- The increased risk is observed sooner with the use of combined estrogen-progestin regimens.
- The increased risk with hormone therapy is confined to estrogen receptor-positive tumors, mainly lobular cancers.
- Epidemiologic data indicate that a positive family history of breast cancer or other risk factors should not be contraindications to the use of postmenopausal hormone therapy.
- Women who develop breast cancer while using postmenopausal hormone therapy have a reduced risk of dying from breast cancer compared with never-users. This is probably because of two factors: (1) increased surveillance and early detection and (2) an effect on preexisting tumors so that tumors appear at a less virulent and less aggressive stage.
- The most important unanswered question in regard to breast cancer is whether postmenopausal hormone therapy initiates the growth of new breast cancers or whether the epidemiologic findings reflect an impact on preexisting tumors. A summary of the wide range of evidence supports a favorable effect of hormone therapy on preexisting tumors.
- Epidemiologic studies find an increased risk within a few years of hormonal exposure.
- Breast cancer associated with estrogen-progestin therapy is estrogen receptor-positive, lower-grade, lower-stage disease with better survival rates.
- Epidemiologic studies find an increased risk only in current users; 5 years after discontinuation, the risk returns to baseline.
- A recent rapid decrease in breast cancer prevalence coincides with a decrease in the use of postmenopausal hormone therapy.

**Postmenopausal hormone therapy may be associated with a small increase in the risk of breast cancer. Of course, even a small increase in risk for breast cancer is frightening for patients to contemplate. It is helpful to remind patients of the risk**

**of lung cancer associated with smoking (a relative risk of 10–20), a risk magnitude that provides perspective on the possible risk associated with hormone therapy. It is also worth pointing out that the reported risk with hormone therapy is even smaller than that associated with recognized risk factors such as a positive family history, being overweight after menopause, and alcohol intake. In our view, because the literature is sufficiently strong, it is appropriate to share with patients an alternative explanation for the epidemiologic reports regarding breast cancer and postmenopausal hormone therapy. It is helpful to emphasize the possibility that the studies reflect an effect of hormone therapy on pre-existing tumors and that hormone users who develop breast cancer have a reduced risk of dying of breast cancer because their tumors are better differentiated, more localized, and smaller. Contrary to the prevailing belief, estrogen-progestin exposure may cause greater differentiation and earlier detection of preexisting tumors, resulting in better outcomes.**

# ENDOMETRIAL NEOPLASIA

---

There are two different types of endometrial cancer. The more common form, endometrioid carcinoma, develops slowly from a precursor lesion in response to estrogen stimulation. This type is less aggressive, is better differentiated, and responds to progestational treatment. In contrast, the uncommon form (perhaps 10–20%) develops rapidly, usually in older women, with a histologic pattern that is more characteristic of serous or clear cell carcinomas, in a background of atrophic endometrium.

Estrogen normally promotes mitotic growth of the endometrium. Abnormal progression of growth through simple hyperplasia, complex hyperplasia, atypia, and early carcinoma has been associated with unopposed estrogen activity, administered either continuously or in cyclic fashion. **Only 1 year of treatment with unopposed estrogen (0.625 mg conjugated estrogens or the equivalent) will produce a 20% incidence of endometrial hyperplasia, largely simple hyperplasia.** In the 3-year PEPI trial, 30% of the women on unopposed estrogen developed adenomatous or atypical hyperplasia.<sup>566,569,570</sup> Some 10% of women with complex hyperplasia progress to frank cancer, and complex hyperplasia is observed to antedate adenocarcinoma in 25–30% of cases. **If histologic evidence of atypia is present, 20–25% of these cases will progress to carcinoma within a year.**<sup>1442</sup>

Approximately 40 case-control and cohort studies estimated that the risk of endometrial cancer in women on estrogen therapy (unopposed by a progestational agent) is increased by a factor of somewhere from 2 to 10 times the background incidence of 1 per 1,000 postmenopausal women per year.<sup>1443,1444</sup> **The risk increases with the dose of estrogen and with the duration of exposure** (reaching a 10-fold increase with 10–15 years of use, perhaps an incidence of 1 in 10 with very long-term use) **and lingers for up to 10 years after estrogen is discontinued.**<sup>1445,1446,1447</sup> The risk of cancer that has already spread beyond the uterus is increased threefold in women who have used estrogen a year or longer.<sup>1445,1448</sup> Although most endometrial cancer associated with estrogen use is of low grade and stage, and associated with better survival (probably because of early detection), the overall risk of invasive cancer and death is increased. The risk of endometrial hyperplasia and cancer is not reduced by the administration of unopposed estrogen in a cyclic fashion (a period of time each month without treatment).<sup>1443,1449</sup>

A short-term study (2 years) indicated that estrogen-only treatment in one-half the usual standard dose of estrogen (in this case, 0.3 mg esterified estrogens) was not associated with an increased incidence of endometrial hyperplasia compared with a placebo group.<sup>1450</sup> In a similar 2-year study, endometrial stimulation with the

transdermal delivery of a very low dose of estradiol, 14 µg/day, also did not differ compared with placebo.<sup>1451</sup> However, **we have learned that long-term exposure to low levels of estrogen can induce abnormal endometrial growth (it just takes longer), and, in our view, lower-dose estrogen therapy requires either endometrial assessment annually or the addition of a progestin to the treatment regimen.** This is supported by a case-control study from Washington that contained 18 cases and 9 controls who had exclusively used only 0.3 mg/day of unopposed conjugated estrogens.<sup>1452</sup> The use of this half-dose estrogen was associated with an overall fivefold increased risk of endometrial cancer, reaching a relative risk of 9.2 in current users for more than 8 years' duration. Although limited by small numbers, the conclusion is logical and consistent with our understanding of the importance of duration of exposure to any increased level of endometrial estrogen stimulation. In a randomized trial, endometrial hyperplasia was increased after 2 years of treatment with 0.3 mg conjugated estrogens without a progestin.<sup>572</sup>

**The risk of endometrial excessive proliferation is reduced by the addition of a progestational agent to the treatment regimen.**<sup>566,570</sup> Although estrogen promotes the growth of endometrium, progestins inhibit that growth. This counter effect is accomplished by progestin-induced reduction in cellular receptors for estrogen and by induction of target cell enzymes that convert estradiol to the excreted metabolite estrone sulfate. As a result, the number of estrogen receptor complexes that are retained in the endometrial nuclei is decreased, as is the overall intracellular availability of the powerful estradiol. In addition, progestational agents suppress estrogen-mediated transcription of oncogenes.

Reports of the clinical impact of adding progestin in sequence with estrogen include both the reversal of hyperplasia and a diminished incidence of endometrial cancer.<sup>1453,1454,1455,1456,1457,1458</sup> The protective action of progestational agents operates via a mechanism that requires time in order to reach its maximal effect. For that reason, the duration of exposure to the progestin each month is critical. Studies indicate that in estrogen users, the minimal requirement for progestin exposure is for a period of 10 days each month.<sup>188,1459,1460</sup> More recently, this recommendation has been extended to 12–14 days of progestin exposure each month. **About 2–3% of estrogen-using women per year develop endometrial hyperplasia when the progestin is administered for less than 10 days monthly.**

Important unanswered questions are the following: what is the actual incidence of endometrial cancer in very long-term users of postmenopausal hormone therapy, and are there differences among the various regimens and routes of administration? A case-control study from Seattle reported that the use of combined estrogen-progestin (essentially all sequential and oral) for 5 or more years was associated with an

increased relative risk of endometrial cancer, even with 10–21 days of added progestin per month.<sup>1461</sup> However, the increased risk was confined to those women who had been previously exposed to unopposed estrogen treatment; remember, **after discontinuing unopposed estrogen treatment, the risk of endometrial cancer lingers for up to 10 years, even if a subsequent regimen includes a progestin.** In the Swedish prospective cohort in Uppsala, a reduced risk of mortality due to endometrial cancer was observed in women receiving an estrogen-progestin combination; however, there were only two deaths, precluding statistical significance.<sup>1135</sup> A case-control study from Los Angeles found no increased risk of endometrial cancer with the continuous, combined estrogen-progestin regimen or when at least 10 days of progestin were provided in a sequential regimen.<sup>1460</sup> **Epidemiologic studies have suggested that continuous, combined estrogen-progestin regimens provide superior protection against endometrial cancer. Long-term sequential regimens still carry a small increase in the risk of endometrial cancer.**<sup>600,1462,1463</sup> **In our view, periodic endometrial surveillance (annual sonohysterogram and/or endometrial biopsy) is recommended in estrogen users exposed only intermittently to progestin treatment.**

It is not an uncommon perception that protection against endometrial cancer requires periodic “shedding” of the endometrium. However, we know that at least one-third and up to one-half of the functioning endometrium are not lost during withdrawal bleeding, and it has not been established that endometrial shedding is essential to protect against cancer.<sup>1464</sup> It is just as logical to believe that prevention of growth with the development of atrophic endometrium is protective. Case-control studies have indicated that not only is the excess risk associated with unopposed estrogen prevented by continuous, combined estrogen-progestin regimens, but with increasing duration of use, the risk of endometrial cancer is lower than that in never-users.<sup>1462,1465</sup> In a small number of women who developed hyperplasia on a sequential regimen, conversion to continuous, combined treatment produced a return to normal endometrium, and in 345 women who completed 5 years of treatment with a continuous, combined regimen, not a single case of hyperplasia was detected.<sup>587</sup>

The WHI reported a 21% decrease in endometrial cancers in the canceled estrogen-progestin arm after 5 years of this clinical trial, although this difference was not statistically significant.<sup>1466</sup>

The lowest daily dose of progestin that protects the endometrium has not been established. Currently, the sequential program with conjugated estrogens uses 5 or 10 mg medroxyprogesterone acetate, and the combined daily method uses 1.5 or 2.5 mg. A 2-year study has indicated that 1.5 mg medroxyprogesterone acetate combined with 0.3 or 0.45 mg conjugated estrogens effectively prevents endometrial hyperplasia.<sup>572</sup> The

dose of norethindrone that is comparable with 2.5 mg medroxyprogesterone acetate is 0.25 mg.<sup>573</sup> The French E3N cohort study has demonstrated that endometrial safety effects vary by type of progestin; the risk of endometrial cancer in estrogen users was higher when micronized progesterone and dydrogesterone were used compared to other progestin formulations.<sup>1467</sup>

**Although the protective effect of progestin is considerable and predictable, it is unwise to expect all patients on estrogen-progestin therapy to never develop endometrial cancer. Appropriate monitoring of patients cannot be disregarded. Although routine assessments are not cost-effective, interventions directed by clinical responses are prudent and necessary. Greater surveillance is warranted in women on sequential estrogen-progestin regimens.**

# OVARIAN CANCER

---

Prospective cohort studies concluded that the risk of fatal ovarian cancer is increased with long-term estrogen use.<sup>1468,1469,1470,1471,1472,1473,1474</sup> And some case-control studies reported a small increase in risk in ever users that was higher with long duration of use.<sup>1475</sup> However, by no means is it certain if this association between menopausal hormone use and ovarian cancer is real. A pooled analysis of 12 case-control studies could find no consistent evidence for an association between ovarian cancer and estrogen therapy.<sup>1476</sup> A meta-analysis concluded that there is a 14% increased risk of ovarian carcinoma among ever users of hormone therapy and that this risk increased to 27% with more than 10 years of hormone use.<sup>1477</sup> However, existing data included in this meta-analysis are subject to multiple potential biases. Among the six studies included in the analysis of duration of use, only one reported a statistically significant increase in risk with 10 or more years of hormone use. Another meta-analysis concluded that there was no clear evidence of an increased risk of ovarian cancer with estrogen therapy and no effect of increasing duration of hormone use.<sup>1478</sup>

Individual studies have been hampered by relatively small numbers, but the lack of a uniform and consistent association argues against a major impact of postmenopausal estrogen treatment on the risk of ovarian cancer. In a relatively large case-control study, no indication could be found for an association between postmenopausal hormone therapy and the risk of epithelial ovarian cancer, even with long-term treatment.<sup>1479</sup> Another case-control study reported a slightly increased risk, but it was not statistically significant.<sup>1480</sup> And another case-control study could find no increase in risk with ever use, past use, or long duration of use (and no differences comparing various estrogens and regimens).<sup>1481</sup> In a comparison of users and nonusers of hormone therapy in the state of Washington, the risk of epithelial ovarian cancer was increased among current and recent users of estrogen only, but not in past users or in users of estrogen-progestin.<sup>1482</sup>

The canceled estrogen-progestin arm of the WHI reported an increase in ovarian cancer that was not statistically significant (HR = 1.58; CI = 0.77–3.24), prompting this statement: “The possibility of an increased risk of ovarian cancer incidence and mortality remains worrisome and needs confirmation.”<sup>1466</sup> The Kaplan-Meier curves suggested an increasing effect over time, but this, too, was not statistically significant. There were no differences reported in histologic type, stage, or grade (but the small numbers made it essentially impossible to assess subcategories).

All of the studies found it difficult to control for most of the factors that influence the risk of ovarian cancer. This is because there are multiple factors, and information regarding each factor is not readily available.



## Factors that decrease the risk of ovarian cancer

- Use of steroid hormone contraceptives
- Pregnancy and parity; a greater effect with a recent pregnancy and pregnancy at older age<sup>1483,1484</sup>
- Breastfeeding<sup>1485</sup>
- Hysterectomy and tubal ligation<sup>1486</sup>
- NSAIDs<sup>1487</sup>

## Factors that increase the risk of ovarian cancer

- Increasing BMI<sup>1488,1489</sup>
- Infertility<sup>1490</sup>

Family history of ovarian and breast cancer<sup>1473</sup>

### Mixed reports on risk

- Alcohol intake<sup>1491,1492</sup>
- Cigarette smoking<sup>1493,1494,1495</sup>

Because of the many factors that influence the risk of ovarian cancer, case-control and cohort studies have found it difficult (in fact, impossible) to match cases and controls. Hormone users usually have used more oral contraceptives, have had fewer children, and are more educated and thinner. Adjustments have been made only for major factors, such as oral contraceptive use. The technique of meta-analysis is especially hampered by these confounding issues.

A major problem has been the impact of endometrioid cancers, an ovarian cancer that logically can be expected to be influenced by estrogen therapy. In many of the studies, the overall results are swayed by the increase in endometrioid cancers, a cancer that could originate in hormonally stimulated endometriosis.<sup>1496</sup> An accurate analysis requires a separate consideration of endometrioid cancers, but this is difficult because the small numbers do not allow effective subcategorization.

An Australian case-control study reported a statistically significant increase only in the 18 cases with endometrioid cancer.<sup>1497</sup> A Swedish case-control study reported a small but significant increase in risk with unopposed estrogen and with sequential estrogen-progestin, but 49% of the cases were endometrioid cancers.<sup>1475</sup> In a cohort report from the Breast Cancer Detection Demonstration Project, only endometrioid cancer was significantly increased.<sup>1469</sup> In the WHI, there were two endometrioid

cancers in the treated group and none in the placebo group.

It should also be noted that in one randomized trial, a case-control study, and two retrospective cohort analyses, no detrimental effect on prognosis after surgery for ovarian cancer could be detected in patients subsequently treated with hormones.<sup>1498,1499,1500,1501</sup>

**Overall, there is an indication that ever users of hormone therapy, no matter what formulation, progestin, or treatment regimen, have a small increase in the risk of epithelial ovarian cancers. The data are consistent with a promotional effect on existing malignancies because the risk diminishes after discontinuation of treatment. It is not difficult to review the epidemiologic data and conclude that there is no uniform story, that there are studies with both positive and negative results, and that most of the studies struggled with limited power because of small numbers and all of the studies are affected with confounding because of the difficulties in assessing and controlling for risk factors. The case-control and cohort studies inconsistently controlled for level of education, parity, oral contraceptive use, BMI, tubal ligation, and family history of ovarian and breast cancer (not a single study controlled for all the known risk factors!). It is a real possibility that there exists an increased risk for the hormonally sensitive ovarian cancer of the endometrioid type, and studies should carefully segregate this cancer for separate analysis. It is appropriate to emphasize the weak associations and the mixed story, but at the same time, the seriousness of the specific relationship dictates that the association between postmenopausal hormone therapy and the risk of ovarian cancer remains an unresolved issue.**

# COLORECTAL CANCER

---

A number of observational studies show a reduced risk of colorectal cancer in those taking hormone therapy.<sup>1502,1503,1504,1505,1506,1507,1508,1509,1510,1511</sup> The effect is greatest in current users and most studies have not indicated an increased effect with increasing duration of use; for example, the Nurses' Health Study (which found a 34% reduced risk in current users) could not demonstrate an added benefit with longer duration of hormone use.<sup>1512</sup> A reduction in fatal colon cancer has also been documented in current users.<sup>1505,1513</sup> In addition, there appears to be a reduced risk of polyps, especially large polyps, among current and recent hormone users. A reduced risk of colorectal cancer has also been reported with a high intake of phytoestrogens.<sup>911,1514</sup>

The canceled estrogen-progestin arm of the WHI reported a statistically significant 44% reduction in incidence of colorectal cancer, and this was achieved within only a few years of estrogen-progestin therapy.<sup>1040</sup> This result in the estrogen-progestin arm was not without concern however, in that the hormone-treated group had more advanced disease. Indeed, the conclusion was largely because of a difference in localized disease, 10 cases in the treated group and 36 in the placebo group. The results suggest that already-present cancers were influenced by hormone therapy to reach a more advanced stage, but that estrogen-progestin treatment reduced the risk of new colonic cancers. Unlike the combination regimen arm of WHI, there was no significant difference in the occurrence of colorectal cancer among hormone users or placebo group in the estrogen-alone WHI trial.<sup>1515</sup> However, it must be appreciated that the E-alone WHI trial had two important problems when contrasted with the EP trial: a very high drop-out rate and about 6,000 fewer participants. Furthermore, interpretability of WHI results must be confined to older postmenopausal women, an age group where carcinogenetic events are likely already underway. Analysis of the California Teacher study for risk of invasive colon cancer also revealed a decreased risk in postmenopausal women taking hormone therapy.<sup>1516</sup> In another case-control study, both oral and transdermal hormone therapies reduced the risk for developing colorectal cancer.<sup>1517</sup>

While the mechanisms underlying decreased colorectal cancer risk in HT users remain unclear, a few hypotheses have been put forth. The estrogen-induced change in the bile (a decrease in bile acids with an increase in cholesterol saturation) favors gallstone formation but may reduce the promotion (by bile acids) of colonic cancer. Other possible mechanisms include a direct suppressive effect of hormones on mucosal cell growth and an effect on beneficial mucosal secretions. The colon contains only estrogen receptor- $\beta$ , and the reduction in the risk of colonic cancer associated with postmenopausal estrogen therapy may reflect an antiproliferative activity of the beta

estrogen receptor. **This potential benefit deserves greater attention; colorectal cancer ranks third in women, both in incidence and mortality, and is more prevalent than cancers of the uterus or ovary.**<sup>1232</sup> **However, it should be noted that data supporting benefits of HT against colon cancer are not uniform, and until clarity is attained, there is no place for use of HT for prevention of colon cancer.**

# LUNG CANCER

---

The leading cause of cancer mortality in American men and women is lung cancer; 87% of the deaths occur in smokers and there are twice as many deaths from lung cancer in women as with breast cancer, annually.<sup>1232</sup> In a post hoc analysis that combined data from 0 to 4 years of follow-up with the treatment period in the canceled estrogen-progestin arm of the WHI, the incidence of non-small cell lung cancer, the type that accounts for about 80% of cases of lung cancer, was nonsignificantly increased, but the number of deaths and the number of poorly differentiated and metastatic tumors were increased in the treatment group.<sup>1518</sup> The cases were essentially limited to past and current smokers and to women over age 60. Although the WHI was not designed to assess lung cancer and chest imaging was not part of the study protocol, the results are provocative and concerning.

There is reason to believe lung cancer might be a target tissue for estrogen; at the same time, there is evidence to indicate that the impact is not uniformly detrimental and may even be protective. Estrogen receptors are present in normal and non-small cell lung cells.<sup>1519</sup> Case-control studies have indicated a decrease in risk for lung cancer and specifically for non-small cell tumors.<sup>1520,1521,1523,1524</sup> Two studies even reported a protective effect in hormone users against lung cancer especially in smokers.<sup>1525,1526</sup> One study reported decreased survival in women with lung cancer who used hormone therapy,<sup>1527</sup> but others did not detect a decreased survival in lung cancer patients with a history of hormone therapy.<sup>1528,1529</sup> The Nurses' Health Study found an increase in lung cancer mortality in women who underwent early bilateral oophorectomy and did not use estrogen.<sup>1210</sup> Gene expression is stimulated in non-small cell lung cancer cells by estrogen, and proliferation of these cells is reduced by an estrogen antagonist.<sup>1530,1531</sup> In the Rancho Bernardo cohort study, there was no significant association between hormone use and lung cancer; however, there was a suggestion that women over age 55 had a small nonsignificant increase in lung cancer; no such increase was noted in younger women using hormones (although not statistically significant, the results with stratification by age are similar to the WHI findings).<sup>1532</sup> **The overall data, including the WHI analysis, suggest that hormone therapy initiated in older women with a history of smoking may promote the growth of existing lung cancers. The WHI evidence in women under the age of 60 is reassuring, and case-control and cohort data that reflect hormone use in a younger population than in the WHI indicate that estrogen is associated with some protection against lung cancer.**

# CERVICAL CANCER

---

Any association between postmenopausal hormone therapy and cancer of the uterine cervix has not been extensively studied. Evidence from one cohort study and one case-control study is reassuring and indicates that the postmenopausal use of estrogen does not increase the risk of cervical cancer.<sup>1533,1534</sup> Indeed, these studies observed protection against cervical cancer in the estrogen users, but this may reflect detection bias (more examinations and Pap smears in estrogen users). Another case-control study suggested an increased risk in cervical adenocarcinomas, but there were only 13 cases.<sup>1535</sup> In a follow-up report of 120 women treated for stage I and II cervical cancers, no associations with hormone therapy as regards survival or recurrence were observed.<sup>1536</sup>

# MALIGNANT MELANOMA

---

The possibility of a relationship between exogenous hormones and cutaneous malignant melanoma has been the subject of many observational studies. Accurate evaluation utilizing the Royal College of General Practitioners and Oxford Family Planning Association prospective cohorts and accounting for exposure to sunlight did not indicate a significant difference in the risk of melanoma comparing users of oral contraceptives to nonusers.<sup>1537,1538</sup> Results with the use of postmenopausal estrogen therapy have not indicated a major impact. A slightly increased risk with long-term use of estrogen was noted in one case-control study (a conclusion based on 10–20 cases and not achieving statistical significance), whereas other case-control studies could find no association with postmenopausal estrogen treatment.<sup>1539,1540,1541,1542,1543</sup> Others have reported slight increases in the risk of malignant melanoma associated with the use of exogenous estrogen, but all failed to reach statistical significance.<sup>1533,1539,1544</sup> In an analysis of cancer incidence in a Swedish cohort of women prescribed postmenopausal hormone therapy, no increase in malignant melanoma was observed.<sup>1281</sup> On the adverse side, a Dutch case-control study reported a significant 42% increase in melanoma risk in postmenopausal hormone users, but it was based on only 33 cases and there was no consideration of sun exposure.<sup>1545</sup> In post hoc analyses of the two WHI trials, HT did not affect the incidence of melanoma.<sup>961</sup> **No solid evidence exists to suggest an increase in risk for cutaneous malignant melanoma with the use of hormone therapy.**

# METABOLIC EFFECTS

---

Severe hypertriglyceridemia and pancreatitis can be precipitated by the administration of oral estrogen to women with elevated triglyceride levels.<sup>1546,1547</sup> In women with triglyceride levels between 250 and 500 mg/dL, estrogen should be provided with great caution, and a nonoral route of administration is strongly advised in those being considered for hormone therapy. **The triglyceride response to estrogen is rapid, and a repeat level should be obtained in 2–4 weeks. If levels are substantially increased, hormone therapy must be discontinued. A level greater than 500 mg/dL represents an absolute contraindication to estrogen treatment.** Triglyceride levels in the normal range were not affected by progestins in the PEPI trial.<sup>569</sup> An exaggerated triglyceride response to estrogen might be attenuated by a progestin, especially a progestin of the 19-nortestosterone family, and, therefore, the daily, combination method of treatment could be considered for women with slightly elevated triglycerides. **However, the treatment of choice is transdermal estrogen, a route of administration that does not affect triglyceride levels; indeed, triglyceride levels markedly elevated in response to oral therapy return to normal when route of administration is changed to transdermal administration.**<sup>518,521</sup>

Although physiologic and epidemiologic evidence indicates that estrogen use increases the risk of gallbladder disease, the overall impact is not great. The Nurses' Health Study indicated that oral estrogen therapy may carry a 1.5- to 2.0-fold increased risk of gallbladder disease.<sup>1548</sup> The risk of cholecystectomy appeared to increase with dose and duration of use and to persist for 5 or more years after stopping treatment. Other observational studies also reported increased risks of cholecystectomy in past and current users of estrogen.<sup>1192,1549,1550</sup> At least two case-control studies concluded that estrogen use is not a risk factor for gallstone disease in postmenopausal women, although the statistical power was limited by small numbers.<sup>1551,1552</sup> A cross-sectional study of gallstone disease could detect no association with postmenopausal hormone treatment.<sup>1553</sup> In the HERS clinical trial, the relative risk of gallbladder disease was 1.38; however, this did not achieve statistical significance.<sup>1190,1554</sup> The risk of gallbladder disease and gallbladder surgery was significantly increased in both the estrogen-progestin and estrogen-only WHI hormone trials.<sup>1555</sup> This amounted to an increase of 20–30 cases per 10,000 per year in this older population of postmenopausal women. The routine, periodic use of blood chemistries is not cost-effective, and careful monitoring for the appearance of the symptoms and signs of biliary tract disease suffices. It is not certain that this potential problem is limited to oral therapy. Nonoral routes of estrogen administration have been reported to inconsistently increase biliary cholesterol saturation (a lithogenic response).<sup>1556,1557</sup> In the Million Women Study in the



United Kingdom, the risk of gallbladder disease was actually lower with transdermal estrogen compared with oral estrogen, but the many problems with this observational cohort make it difficult to allow a confident statement.<sup>1558</sup>

# Weight Gain

Weight gain in midlife is common, and lifestyle remains the dominant contributor to this occurrence; specifically, the balance of dietary intake and exercise is tilted toward excessive caloric intake because of a decline in physical fitness and the age-related decrease in basal metabolic rate. Despite common perception, the weight gain in women around menopause is not due to the hormonal changes associated with menopause.<sup>398,1557,1558,1559,1560</sup> Likewise, postmenopausal hormone therapy cannot be blamed for weight gain. The large Rancho Bernardo prospective cohort study and the randomized PEPI clinical trial documented that hormone therapy with or without progestin does not cause an increase in body weight.<sup>1561,1562</sup> In fact, in the PEPI trial, the hormone-treated groups actually gained less weight than the placebo group. In the 2-year clinical HOPE trial assessing the efficacy of lower estrogen-progestin doses, hormonal treatment was associated with lesser increases in body weight and body fat compared with placebo.<sup>1563</sup>

After menopause, there is an increase in abdominal fat and total body fat that is associated with an increase in insulin resistance, a consequence of the decrease in estrogen levels.<sup>1564</sup> Postmenopausal estrogen therapy maintains the premenopausal body habitus, preventing the increases in abdominal fat, insulin resistance, blood pressure, and diabetes mellitus associated with estrogen deficiency.<sup>1565</sup> Estrogen (with or without progestin) prevents the tendency to increase central body fat with aging.<sup>1036,1037,1038,1039,1566</sup> This would inhibit the interaction among abdominal adiposity, hormones, insulin resistance, hyperinsulinemia, blood pressure, and an atherogenic lipid profile that results in the metabolic syndrome. An excellent randomized trial in Denmark documented less weight gain with hormone therapy because of a smaller increase in fat mass.<sup>1567</sup> In a substudy of the WHI, assessments of body composition by dual-energy x-ray absorptiometry (DEXA) indicated that estrogen-progestin users had less fat and greater lean mass.<sup>1568</sup> This same salutary effect on central body fat has also been observed with tibolone treatment.<sup>1569</sup> **Rather than causing body weight gain, therefore, postmenopausal hormone therapy reduces the increase in insulin resistance and abdominal fat usually seen with aging, with a beneficial impact on the risks of hypertension, diabetes mellitus, and dyslipidemia.**

# **PRESENTATIONS REQUIRING CLINICAL JUDGMENT**

---

# Patients with Endometrial Cancer, Endometrioid Tumors, and Endometriosis

Gynecologic oncologists have reported that hormone therapy can be safely considered in patients who have had stage I and stage II adenocarcinoma of the endometrium without fear of an increased risk of recurrence or a decrease in disease-free interval.<sup>1570,1571,1572,1573</sup> In a matched cohort of 249 women with stage I, stage II, and stage III endometrial cancer with a long follow-up, there was no indication of an increase in recurrent disease with hormone therapy.<sup>1574</sup> Similar negative results were reported in a Turkish case-control study.<sup>1575</sup> The only randomized trial, organized by the Gynecologic Oncology Group, closed prematurely because of recruitment difficulties following the publicity associated with the WHI.<sup>1576</sup> Nevertheless, a total of 1,236 patients with stage I or stage II endometrial cancer were randomized to either estrogen-only or placebo, and although the participants constituted a low-risk group, the recurrence rate was low, 14 recurrences with 5 deaths in the treatment group and 12 recurrences and 9 deaths in the placebo group. If a high-risk tumor is estrogen- and progesterone receptor negative, it seems reasonable to allow immediate initiation of hormone therapy. Because the latent period with endometrial cancer is relatively short, a period of time under observation (5 years) without evidence of recurrence would increase the likelihood of long-term safety on an estrogen program. **We recommend that hormone therapy be avoided in patients with high-risk tumors that are receptor positive until 5 years have elapsed. The combination of estrogen-progestin is recommended in view of the potential protective action of the progestational agent. A similar approach makes sense for patients previously treated for endometrioid tumors of the ovary. In view of the fact that adenocarcinoma has been reported in patients with pelvic endometriosis and on unopposed estrogen, and that estrogen-alone may allow for recurrence of endometriosis, the combined estrogen-progestin program is also advised in patients with a past history of endometriosis.**<sup>1577,1578,1579,1580,1581,1582</sup>

# Should a Postmenopausal Woman Who Has Had Breast Cancer Use Hormones?

The argument that postmenopausal hormone therapy should not be given to women who have had breast cancer is a reasonable one. It is based on the recognition of a large body of evidence that indicates that breast cancer is often a hormone-responsive tumor. The overriding fear of many clinicians (and patients) is that metastatic cells are present (perhaps being controlled by various host defense factors) that will be susceptible to stimulation by exogenous hormones.<sup>1583</sup> However, many women who have had breast cancer are aware of the benefits of postmenopausal hormone treatment and are asking clinicians to help make this risk-benefit decision. In addition, some women suffer from such severe hot flushing and vaginal dryness that they are willing to consider hormonal treatment. Tibolone treatment of breast cancer survivors is relatively contraindicated as discussed earlier in this chapter.

The rate of recurrent breast cancer in hormone users has been reported in multiple case series with more than 1,000 breast cancer survivors.<sup>1584,1585,1586,1587,1588,1589,1590,1591,1592,1593,1594,1595,1596,1597,1598,1599,1600</sup> It is reassuring that the recurrence rates in these reports are not different from the expected rate of breast cancer recurrence. In one series, 25 and then 77 women with breast cancer ranging from in situ to stage III disease received estrogen-progestin therapy for 24–82 months; the recurrence rate was not greater than that expected.<sup>1587,1588</sup> From this group of patients, 41 breast cancer survivors receiving hormone therapy had the same outcomes when compared with 82 women selected from a cancer registry and not taking hormones.<sup>1588</sup> In a report from Australia, 90 women with a history of breast cancer who were given a combination of estrogen and progestin had lower mortality and recurrence rates; however, the dose of progestin was very high (which in itself can be therapeutic) and treatment was not randomized.<sup>1592</sup> In a follow-up of 319 women treated with estrogen after treatment for localized breast cancer, only one patient developed recurrent disease.<sup>1593</sup> In a matched-controlled series of 277 breast cancer survivors, there was no difference in the estrogen-treated group and the control group for recurrent disease.<sup>1600</sup> A series with 114 women who received hormone treatment had a low rate of recurrence.<sup>1589</sup> These patients have had both positive and negative nodes and positive and negative estrogen receptor status. Although the results conform to an incidence of recurrent disease no greater than expected, the outcomes can reflect biases in clinician and patient decision-making that can only be overcome with a proper long-term, randomized clinical trial.

A case-control study of hormone therapy after breast cancer actually found a

significant reduction in risk of recurrent disease, breast cancer mortality, and total mortality in hormone users.<sup>1601</sup> Again, these are reassuring observational data that hormone therapy after breast cancer has no adverse impact on recurrence.

A U.S. trial at the University of Texas M.D. Anderson Cancer Center provided estrogen to randomized women who had been treated for localized stage I and stage II breast cancer with either ER-negative or ER status unknown tumors.<sup>1602</sup> After 5 years of follow-up, 56 women in the trial receiving estrogen were compared with 243 women with comparable disease not receiving estrogen; there was no adverse effect of estrogen treatment on disease-free survival.<sup>1603</sup>

A multicenter, large case-control study of women younger than 55 years with breast cancer concluded that the use of oral contraceptives or postmenopausal hormone therapy either before or after diagnosis did not increase the risk of the first breast cancer or recurrent breast cancer.<sup>1604</sup> This negative finding was not changed by duration of use or age of oral contraceptive use or by BMI, duration of use, or type of postmenopausal hormone use (estrogen only or combined estrogen-progestin).

## **The HABITS Trial**

“Hormonal replacement therapy After Breast cancer—Is it Safe?” (HABITS) began in multiple centers in Sweden in May 1997, to compare breast cancer survivors treated for at least 2 years with hormone therapy with treatment other than hormones. A similar trial was initiated in Stockholm. Because recruitment was slower than anticipated, the two trials agreed in February 2002 to pool their patients and to use a joint safety and monitoring committee. In October 2003, the safety committee recommended that the trial be discontinued because there were 26 women in the treated group with new breast cancers compared with 7 in the nontreated group. The HABITS trial was terminated in December 2003.<sup>1605</sup> Confronted with this outcome, the Stockholm investigators decided to cancel their trial as well even though the hazard ratio in the Stockholm patients was 0.82 (CI = 0.35–1.9).

HABITS was a randomized but not placebo-controlled trial in which hormone therapy was compared to management without hormones in women with menopausal symptoms who had been previously treated for stage I or stage II breast cancer. Concomitant use of tamoxifen treatment was allowed in the HABITS patients but not of aromatase inhibitors. Hormone therapy consisted of the variety of products and methods on the Swedish market, but not tibolone. Most of the treated women used products with the relatively high dose of 2 mg estradiol. After 4 more years of follow-up of 442 women, there were 39 cases of new breast cancer in women using hormone therapy compared with 17 in the nontreated group, for a hazard ratio of 2.4 (CI = 1.3–4.2).<sup>1606</sup>

It is important to appreciate some significant concerns related to the study design and methodology in HABITS. The treated and nontreated groups of women were very different in terms of characteristics and behaviors. More of the women in the treated group had hormone receptor-positive cancers (62.3%) compared with the nontreated group (54.5%). Protocol deviations occurred; 11 women in the treated group never received hormones, whereas 43 in the nontreated group did receive hormones. There was a very wide range of exposure times, ranging from 0 to 80 months. About one-third of the women who received hormones changed products during the study. The method of analysis of the HABITS data was intent-to-treat, and thus the impact of these differences cannot be ascertained.

Analysis of the new breast cancers in HABITS (either local recurrences or contralateral cancers) indicated statistically significant increases only in hormone receptor-positive cancers. However, when adjusted for use of hormone therapy before diagnosis of the original breast cancer, use of tamoxifen, and hormone receptor status, the hazard ratio was 2.2 with a CI that included 1 (1.0–5.1), which by definition, while close, is not statistically significant.

The Stockholm trial reported in 2005, after a median follow-up of 4.1 years, 11 new breast cancers in the treated arm and 13 new breast cancers in the nontreated arm.<sup>1607</sup> Why there is difference between the Stockholm trial and HABITS? The HABITS investigators suggest that their patients had more node-positive disease and thus “probably” had more women with subclinical disease that would be stimulated by hormone therapy. Another possibility was more protection with higher tamoxifen use in the Stockholm trial, although the HABITS trial could detect no impact of tamoxifen. The HABITS investigators believe that another possible explanation was the greater use of norethindrone and norethindrone acetate in HABITS compared with the use of medroxyprogesterone acetate in Stockholm. All of these explanations are speculations; the difference between the two trials remains and calls into question the reliability and accuracy of the data.

The cancellation of HABITS and the Stockholm trials made it impossible for the English and Italian trials to continue recruitment, and they were also canceled. Thus, the scientific community was left with many questions, but without ongoing efforts to elucidate answers. In our view, the existing data on risk of breast cancer recurrence or new-onset cancers related to hormone therapy are far from being definitive.

**Although intuitively it seems that the risk/benefit ratio would be more favorable in the presence of negative nodes, negative receptors, and small tumors, are negative estrogen and progesterone receptor assessments by themselves sufficient to conclude that the cancer is not sensitive to hormones? And if the patient is in the high cure category, does it make any difference what the receptor**

**status is? The answers to these questions are not known. Receptor status is not absolute; it is always a relative measure and can change over the course of disease progression.**

**Patients and clinicians have to incorporate all of the previously mentioned considerations into medical decision-making. But when all is said and done, patients have to take an unknown risk if they want the benefits of hormone treatment; the prescribing clinicians too take an unknown medical-legal risk. Some patients who are burdened by severe menopausal symptoms that remain unresponsive to nonhormonal interventions may and do choose to take estrogen, judging the benefits to their quality of life with hormone use to be worth the unknown risk. Until definitive data are available from clinical trials, clinicians should support patients in this decision. Other patients will prefer to avoid any unknown risks. These patients, too, deserve support in their decision.**



# IMPLICATIONS OF HORMONE THERAPY FOR WOMEN WITH DIABETES MELLITUS

---

Estrogen can improve the metabolic changes associated with diabetes. Indeed, in prospective studies of postmenopausal women with type 2, non-insulin-dependent diabetes mellitus, estrogen-only or estrogen-progestin therapy improved all glucose metabolic parameters, including insulin resistance, the lipoprotein profile, and measurements of androgenicity.<sup>1049,1050,1466,1608,1609,1610,1611,1612</sup> One study, however, could detect no impact with transdermal administration.<sup>1610</sup> These changes should reduce the risk of cardiovascular disease, and in a very large cohort of 24,420 women from the Northern California Kaiser Permanente Diabetes Registry, current use of hormone therapy reduced the risk of myocardial infarction, but in women with a recent heart attack, an increased risk of a recurrent myocardial infarction was observed in hormone users (again a difference between primary prevention and secondary prevention).<sup>1613</sup> Tibolone also has a beneficial impact in short-term studies on insulin resistance in normal women and in women with non-insulin-dependent diabetes mellitus.<sup>720,744</sup> Raloxifene, a SERM, has no effects on glucose metabolism or insulin sensitivity in normal women but exerts a modest improvement in insulin resistance in women who are hyperinsulinemic.<sup>1614,1615</sup>

# IMPLICATIONS OF HORMONE THERAPY FOR WOMEN WITH LIVER DISEASE

---

In an evaluation of liver chemistries in a group of patients with primary biliary cirrhosis, standard hormone therapy doses produced no adverse changes over a period of 1 year.<sup>1616</sup> Estrogen treatment, either oral or transdermal, has not been associated with worsening cholestasis in women with primary biliary cirrhosis.<sup>1617,1618</sup> We recommend measurement of liver chemistries after 1 month of treatment and every 6 months, with continuing hormone therapy in the absence of deterioration.

A French cohort study concluded that hormone therapy protects against the progression of hepatic fibrosis from chronic hepatitis C.<sup>1619</sup> Most individuals with hepatitis C virus infection develop chronic disease, a major cause of worldwide morbidity and mortality from liver fibrosis. The time course is relatively slow, taking years to progress from infection to cirrhosis. Progression is increased by consumption of alcohol, excess body weight, diabetes, and the degree of fatty degeneration in the liver. The severity of liver fibrosis is greater in men, and progression in women accelerates around age 60. In vitro and animal experiments have documented a beneficial effect of estrogen on the development of fibrosis, an effect that is consistent with the data in the French study finding greater progression of fibrosis after menopause and amelioration with hormone therapy. Another French study, a retrospective survey, reported a greater rate of fibrosis progression with hepatitis C in postmenopausal and nulliparous women and a lower rate in postmenopausal women treated with hormone therapy compared with nontreated women.<sup>1620</sup>

Liver fibrosis from hepatitis C infection is not the result of viral destruction of hepatic cells. Fibrosis is a response to the inflammatory activity incited by the virus. By now, it is well known that estrogen can suppress the secretion of proinflammatory cytokines. Because of the prevalence of hepatitis C infection, these French reports are very important. Many clinicians are reluctant to prescribe hormone therapy to women with a history of liver disease. However, as long as liver enzymes are normal, there is no reason to withhold treatment, and these French studies indicate that estrogen therapy is beneficial. Postmenopausal hormone therapy should be discussed when women present with a history of hepatitis C infection.

The lesson learned from the above conditions is that estrogen-alone and estrogen-progestin treatment including contraception is acceptable as long as liver enzyme function is normal. This caveat is also true for women who have undergone organ transplantation surgery.<sup>1621</sup>

**Hormone therapy should be avoided in the setting of chronically impaired liver**

**function.**

# HORMONE TREATMENT IN THE PRESENCE OF UTERINE LEIOMYOMAS (FIBROIDS)

---

Uterine leiomyomas are monoclonal tumors that retain sensitivity to both estrogen and progestin (Chapter 3); therefore, it is appropriate to be concerned over whether leiomyomas will grow in response to postmenopausal hormone therapy. As assessed by vaginal ultrasonography, the number and size of uterine leiomyomas increased in women being treated with an intramuscular depot form of estrogen-progestin therapy.<sup>1622</sup> However, the hormonal dose in this study was relatively high, certainly higher than standard regimens. At the end of 1 year, women with small asymptomatic fibroids administered with a daily combination of 0.625 mg conjugated estrogens and 2.5 mg medroxyprogesterone acetate had no sonographic evidence of growth in contrast to an increase in size observed with transdermal estradiol (50 µg) and 5 mg medroxyprogesterone acetate daily (a response that probably reflects the effect of a higher progestin dose).<sup>1623</sup> In follow-up studies with standard doses of estrogen-progestin or tibolone, ultrasonography detected no changes in uterine or myoma volumes.<sup>1624,1625,1626</sup> Clinical experience indicates that fibroid tumors of the uterus almost always are not stimulated to grow by the commonly utilized postmenopausal doses of estrogen and progestin. Tibolone and raloxifene also do not stimulate myoma growth.<sup>757,1627,1628</sup> Interestingly, however, a vulvar leiomyoma with growth stimulated by estrogen-progestin treatment has been reported.<sup>1629</sup> A case-control study could find no statistically significant increase in the risk of uterine sarcomas associated with estrogen therapy.<sup>1630</sup> **Nevertheless, in women with known fibroids, periodic surveillance by pelvic examination and transvaginal ultrasound scans is prudent.**

# IMPLICATIONS OF HORMONE THERAPY FOR WOMEN WITH SLEEP APNEA

---

The low prevalence of sleep apnea in premenopausal women and the increased frequency after menopause suggest a hormonal link. In careful studies, however, postmenopausal hormone therapy had no significant adverse effect on sleep-disordered breathing in women with more than mild obstructive sleep apnea.<sup>1631,1632</sup> And other sleep laboratory studies found that estrogen treatment reduced difficulties with sleep-disordered breathing.<sup>1633,1634,1635</sup> The slight rise in basal body temperature induced by a progestational agent may be sufficient to disrupt the quality of sleep in some women, a problem that may be more noticeable with a sequential regimen and with nighttime administration.

# IMPLICATIONS OF HORMONE THERAPY FOR WOMEN WITH ASTHMA

---

In some women, changes in asthma activity have been noted to correlate with phases of the menstrual cycle. The impact of postmenopausal hormone therapy on asthma activity has not been well investigated, but there is an indication that estrogen has an adverse effect. A worsening in spirometry assessment was detected in asthmatics after estrogen therapy; however, the difference was judged to be subclinical, and the patients did not report any changes in their perceptions of symptoms.<sup>1636</sup> A similar study could detect no adverse effects with either discontinuation or reinitiation of estrogen treatment.<sup>1637</sup> And another study concluded that estrogen therapy improved asthma and decreased the need for glucocorticosteroid treatment.<sup>1638</sup> In a prospective assessment of a cohort of women, the use of postmenopausal hormone therapy (estrogen with or without progestin) was associated with a 50% increase in the risk of developing adult-onset asthma, and the risk was greater with long-term use and with higher doses of estrogen.<sup>1639</sup> Similar results were reported in the French E3N cohort study, except an increased risk was observed only in estrogen-alone users.<sup>1640</sup> In the Nurses' Health Study, newly diagnosed asthma was increased about twofold by hormone therapy.<sup>1641</sup> Because hormonal changes may precipitate asthmatic activity (e.g., catamenial asthma), attention should be directed to the symptomatic pattern and consideration given to the daily, continuous, combined regimen.

# MENOPAUSAL HORMONE THERAPY, DEMENTIA, AND COGNITION

---

The WHIMS analyzed the effects of hormone therapy on cognition and on risk of dementia in postmenopausal women participating in the WHI hormone trials. Contrary to earlier assumptions that menopausal estrogen therapy should offer cognitive benefit, the WHIMS concluded that estrogen-progestin and estrogen-only therapy actually increased the risk for dementia in women 65 years and older and did not prevent mild cognitive impairment.<sup>361,362,363,1642</sup> However, the only statistically significant finding in the estrogen-progestin arm was increased dementia (vascular dementia, not Alzheimer disease) in elderly women (22 cases in the treated group and 10 cases in the placebo group) who were 75 and older and who had been exposed to a relatively short term of estrogen-progestin therapy. The estrogen-only arm of the WHI contained more obese women with pre-existing cardiovascular disease, and the trend for an increase in dementia likely reflected an effect in older women with established atherosclerosis. Both timing and duration hypothesis, similar to ones proposed for cardiovascular effects of hormone therapy, emerged in the wake of WHIMS, raising questions that outcomes may differ for those women who initiate hormone therapy early in the course of menopause and in those who following early initiation continue to use hormone therapy for longer durations; hypotheses proposed that unlike WHIMS, women initiating hormone therapy proximate to final menses and who then continue to use hormones for prolonged periods may be protected against dementia. The WHI report recognized that these hypotheses could not be tested in this clinical trial because of the older age of the study participants and remoteness of hormone initiation from onset of menopause. A prospective study of a homogeneous population in Utah (thus minimizing, if not eliminating, the healthy user bias) concluded that a reduction in the risk of Alzheimer's required long-term treatment, initiated at least 10 years before symptoms of dementia appear.<sup>359</sup> Thus, any favorable effects of hormone therapy on cognition and on the risk of Alzheimer disease, if any, appear to be limited to women who initiate treatment close to onset of menopause. However, KEEPSCog, an ancillary study to KEEPS that examined the timing hypothesis as regards effects of hormone therapy initiated within 3 years of onset of menopause, similarly failed to identify cognitive benefit.<sup>369</sup>

## OTHER CONDITIONS

---

Close surveillance is indicated for some patients with seizure disorders and migraine headaches. Patients with migraine headaches often improve with strategies that minimize fluctuations in circulating hormone levels that can serve to trigger headaches. Transdermal route of estrogen administration is preferable given stable hormone profile in comparison to following oral ingestion. Conditions that do not represent contraindications include controlled hypertension, smoking, and varicose veins. The belief that estrogen is potentially harmful with each of these clinical situations is derived from old studies of high-dose oral contraceptives. Estrogen in appropriate doses is acceptable in the presence of these conditions.

No other cancers (in addition to those mentioned previously) are known to be adversely affected by hormone therapy. Postmenopausal hormone therapy can be administered to all patients with a history of cervical, ovarian, or vulvar malignancies.

Highly unusual anecdotal happenings include the following:

- Provocation of chorea by estrogen therapy in a woman with a history of Sydenham chorea<sup>1643</sup>
- Exacerbation of pulmonary leiomyomatosis by estrogen therapy<sup>1644</sup>
- Psychiatric symptoms in response to estrogen in patients with acute intermittent porphyria<sup>1645</sup>
- Idiosyncratic ocular symptoms associated with estrogen<sup>1646</sup>
- Sudden deafness and tinnitus with commencement of hormone therapy<sup>1647</sup>
- Resolution of an infection with *Trichomonas vaginalis* after discontinuation of estrogen-progestin therapy<sup>1648</sup>
- Successful treatment of Sjögren syndrome with tibolone<sup>1649</sup>



# **BEYOND SYMPTOM CONTROL**

---

Some Additional Benefits of Hormone Therapy.

# Estrogen Therapy and Autoimmune Diseases

## Rheumatoid Arthritis

No clear conclusion is apparent from the studies of effects of estrogen on rheumatic diseases, especially rheumatoid arthritis. Some have indicated that exogenous estrogen, either in oral contraceptives or as postmenopausal therapy, protects against the onset of rheumatoid arthritis, whereas other studies find no such effect.<sup>1650,1651,1652,1653</sup> Existing data are hampered by small numbers. In a randomized, placebo-controlled clinical trial, maintenance of standard serum estradiol levels was associated with improvements in some measurements of disease activity in patients with rheumatoid arthritis.<sup>1654</sup> Reassuringly, there has been no evidence that postmenopausal hormone therapy aggravates rheumatoid arthritis or causes a flare in disease activity. **Postmenopausal hormone therapy can be safely considered in symptomatic postmenopausal women with rheumatoid arthritis. Hormone therapy can additionally be considered as a fracture risk reduction strategy in appropriately selected patients (skeletal effects of hormone therapy are discussed in the section on osteoporosis).**

## Systemic Lupus Erythematosus

In the Nurses' Health Study, the use of postmenopausal estrogen was associated with approximately a twofold increase in SLE, an observation based on 30 cases in past and current users of estrogen.<sup>1655</sup> In a follow-up of 60 postmenopausal women with stable SLE, no adverse effects of hormone therapy could be detected.<sup>1656</sup> Patients with SLE develop early atherosclerosis and those treated with glucocorticoids are especially at greater risk for osteoporosis,<sup>1657</sup> but there is a concern that exogenous estrogen will increase flares and stimulate thrombosis because of an existing hypercoagulable state in these patients. Importantly, no increase in arterial or venous thrombosis was observed with postmenopausal hormonal therapy in a longitudinal study of a large cohort of U.S. women with SLE.<sup>1658</sup> **Postmenopausal hormone therapy can be considered in patients with stable or inactive disease, without renal involvement, or high antiphospholipid antibodies, and transdermal route for estrogen administration is advised.**

# Estrogen Therapy and Osteoarthritis

Osteoarthritis is the most common form of arthritis in older people, and its prevalence increases rapidly in women after menopause. Increasing severity of osteoarthritis of the knee has been reported to be associated with increasing bone density and the current use of postmenopausal hormone therapy in middle-aged women.<sup>1659</sup> However, estrogen treatment reduced osteoarthritis in a monkey model, and a cross-sectional study concluded that current users of estrogen had a reduced prevalence of osteoarthritis of the hip, and there was protection against the severity of osteoarthritis, with a greater effect with longer duration of use.<sup>1660,1661</sup> Arthritic complaints are a major side effect of the low estrogen state induced in women with breast cancer treated with aromatase inhibitors, and osteoarthritis develops more frequently in women with the lowest levels of estrogen.<sup>1662,1663</sup> Because there are no known treatments that modify the course of osteoarthritis, this potential benefit of postmenopausal hormone therapy deserves study in appropriately designed randomized clinical trials.

# Estrogen Therapy and the Oral Cavity

Oral complaints are common among postmenopausal women. The administration of estrogen provides significant relief from oral discomfort, burning, bad taste, and dryness<sup>1664</sup>. Estrogen therapy is also associated with a reduction in periodontal disease, including gingival inflammation and bleeding.<sup>1665,1666</sup> These changes may reflect epithelial responses to estrogen by the oral mucosa, in a manner similar to that of the vaginal mucosa. Oral alveolar bone loss (which can lead to loss of teeth) is strongly correlated with osteoporosis, and the salutary effect of estrogen on skeletal bone mass (discussed later in the section on osteoporosis) is also manifested on oral bone.<sup>1667,1668</sup> In the Leisure World Cohort, tooth loss and edentia were significantly reduced in estrogen users compared with nonusers (with a reduced need for dentures), and this beneficial effect was greater with increasing duration of estrogen use.<sup>1669</sup> Approximately a 25% reduced risk of tooth loss in current users of estrogen was observed in the Nurses' Health Study.<sup>1670</sup>

# Estrogen Therapy and the Larynx

Professional singers have used hormone therapy to prevent what they view as unwanted voice changes associated with menopause.<sup>1671</sup> In prospective studies, objective voice analyses have documented a more androgenic change in voice in the early postmenopausal years with a lesser change associated with estrogen treatment; although slightly attenuated by the addition of a progestin, the overall effect of estrogen treatment is to preserve voice quality.<sup>1672,1673,1674</sup> Laryngeal cytology demonstrated epithelial maturation in women on estrogen treatment, and these women reported better voice quality and fewer voice changes compared with a control group.<sup>1675</sup>

# Estrogen Therapy and Vision

There is some evidence that estrogen therapy improves visual acuity (or lessens the visual deterioration during the early postmenopausal years), perhaps due to a beneficial effect on lacrimal fluid.<sup>1676,1677</sup> An increased prevalence of keratoconjunctivitis sicca (dry eyes) in menopausal and postmenopausal women, with symptoms of scratchiness, burning, and photophobia, is recognized by ophthalmologists.<sup>1678</sup> Although reports concluded that there was no effect or even a worsening of dry eyes with hormone therapy, a clinical trial indicated relief from dry eye symptoms with the use of topical estrogen eye drops.<sup>1679,1680,1681,1682,1683</sup>

There is evidence that postmenopausal estrogen therapy has an effect that protects against lens opacities (cataracts).<sup>1684,1685,1686,1687,1688</sup> Estrogen-alone or estrogen-progestin treatment also lowers intraocular pressure in postmenopausal women with normal eyes or glaucoma.<sup>1682,1689,1690,1691</sup> In the Nurses' Health Study, current use of estrogen-progestin, but not estrogen alone, was associated with a reduced risk of glaucoma.<sup>1692</sup>

There is modest evidence that the risk of age-related macular degeneration is reduced in estrogen users, but some studies could detect no effect.<sup>1693,1694,1695,1696,1697</sup>

# Estrogen Therapy and Age-Related Hearing Loss

Demineralization of the cochlear capsule occurs with aging and with metabolic bone diseases, such as cochlear otosclerosis. This demineralization is associated with neural hearing loss. Postmenopausal women (age 60–85 years) who have lower than average femoral neck bone mass have an increased risk of having a hearing loss.<sup>1698</sup> This association between femoral neck bone mass and age-related hearing loss suggests that prevention of bone loss with estrogen therapy might also be exerted on the cochlear capsule. In addition, estrogen may have beneficial effects on cochlear blood flow and central nervous system auditory neurons. Hearing impairment in a Turkish family was associated with an inactivating mutation for estrogen receptor- $\beta$ .<sup>1699</sup> Mouse knockout studies indicate that estrogen receptor- $\beta$  is important for the prevention of age-related hearing loss.<sup>1700</sup> Studies have documented better hearing levels in estrogen users, with an indication that the addition of a progestin attenuated the favorable effect of estrogen.<sup>1701,1702</sup> Interestingly, however, older age at menopause and longer duration of postmenopausal HT were associated with a higher risk of hearing loss.<sup>1703</sup>

# HOW LONG POSTMENOPAUSAL HORMONE THERAPY SHOULD BE CONTINUED?

---

The answer to this question is relatively straightforward. Periodic reassessments of risk-to-benefit ratio must be undertaken in hormone-using women, and **duration of therapy should be guided by the principles of “net benefit” and “do no harm.”** Clarity on persistence of the indication for which hormone therapy was initiated in the first place and overall risk profile of the user should be periodically assessed, and a woman should continue her postmenopausal hormone regimen as long as the potential for benefit outweighs that of harm. The symptom, metabolic, and skeletal effects of hormones revert early following discontinuation, with longer times needed for others may take years (e.g., dissipation in breast cancer risk) after discontinuation.

Resurgence in menopausal symptoms after discontinuing hormonal therapy is not uncommon, and resulting disruption in quality of life has been reported in at least 25% of previously treated women and, in one Swedish study, 70%.<sup>1704,1705</sup> It seems intuitively advantageous to encourage a tapering, gradual discontinuation program to minimize recurrence of menopausal symptoms, although randomized trials comparing gradual discontinuation with abrupt cessation found no benefit with a tapering regimen.<sup>1706,1707,1708,1709</sup> Neither the recurrence rate nor the severity of menopausal symptoms differs comparing the two methods.



# SHOULD WOMEN REMOTE FROM MENOPAUSE BE STARTED ON HORMONE THERAPY?

---

The positive impact of hormone therapy on the bone has been demonstrated to take place even in women older than age 65.<sup>1710,1711</sup> This is a strong argument in favor of treating women remote from menopause who have never been on estrogen and who cannot take or afford the other alternatives for bone preservation. Estrogen treatment that is not begun until after age 60 can with long-term use achieve bone densities nearly but not totally comparable with those in women taking estrogen from menopause, and estrogen use between the ages of 65 and 74 has been documented to protect against hip fractures.<sup>1712,1713</sup> **Adding a hormonal regimen to women over the age of 60 is not a trivial consideration given the known risks of thromboembolism, stroke, and cognitive deterioration that were evident in the WHI hormone trials.** This judgment requires the conclusion that a relatively youthful and vigorous elderly woman has something to gain from the choice of hormone treatment. While patients with osteoporosis may qualify, alternative effective strategies are available to minimize fracture risk, which may prove to be safer alternatives to hormone therapy in the elderly. The primary and secondary prevention trials reviewed in this chapter have strongly indicated that estrogen administered to women with established atherosclerosis is associated with an increased risk of arterial thrombosis. The mechanism, as reviewed in earlier in this chapter, is presumed to be the creation of a prothrombotic environment by the stimulation of metalloproteinase enzyme activity in unstable atherosclerotic plaques. This effect is enhanced by the production of 27-hydroxycholesterol in atherosclerotic sites, a cholesterol metabolite that competitively inhibits estrogen's beneficial actions within blood vessels. Statin treatment is known to stabilize atherosclerotic plaques rapidly, within 3 months. Although there are no studies to support this recommendation, it seems reasonable to consider initiating statin treatment for several months before starting estrogen therapy in older women.

Older women who have been deficient in estrogen for many years often experience side effects when standard doses of estrogen are initiated. Breast tenderness can be especially disturbing. Because of these side effects and the experience in the WHI with its older population, it is better to start older women with lower doses, and transdermal products that deliver low amounts of estrogen must be considered preferentially. The benefits from initiating hormone therapy in aging women must be balanced against risks for harm, and a thorough clinician-patient dialogue must place existing data in perspective including findings from the WHI hormone trials.

# CAN THE DIET PRODUCE VARIATIONS IN SYSTEMIC ESTROGEN LEVELS?

---

Oral estrogens have an extensive first-pass metabolism, both in the gastrointestinal tract and the liver. This metabolism consists chiefly of sulfation and hydroxylation. The cytochrome P-450 system catalyzes the hydroxylation of estrogen, and antioxidants can inhibit this action. Flavonoids (e.g., naringenin and quercetin) are present in high concentrations in fruits and vegetables, and grapefruit juice inhibits estrogen metabolism, producing an increase in bioavailability that is consistent with an inhibition of hydroxylation.<sup>1714,1715</sup> This raises the possibility that dietary interactions with food products could produce a clinical impact. There is great variability within individuals and between individuals in the pharmacokinetics of exogenously administered estrogen. It is possible that this variability partially reflects the dietary habits of individuals and not intrinsic metabolism.

An effect of alcohol ingestion by premenopausal women was not demonstrated on circulating levels of estrone, estradiol, DHEA-S, or SHBG in a cross-sectional study that depended on a questionnaire to assess alcohol intake.<sup>1716</sup> However, when alcohol is administered under experimental conditions, circulating estrogen concentrations are raised to high levels.<sup>113,115</sup> In a prospective cohort study of premenopausal women in Italy, higher estradiol levels were correlated with an increased alcohol intake over a 1-year period of time.<sup>1717</sup> In the last decade, the gut microbiome has emerged as an important variable capable of influencing estrogen metabolism, the metabolic and carcinogenic milieu, as well as modifying interactions between dietary factors and hormones.<sup>1718</sup>

# CLINICAL APPROACH TO POSTMENOPAUSAL HORMONE THERAPY

---

We hope that we have convinced you that menopause is a normal life event, not a disease, and that for many women, postmenopausal hormone therapy can bring about marked improvement in quality of life and, with long-term use, provide health care benefits. Postmenopausal hormone therapy should be considered for symptomatic women traversing the menopause transition and early menopause as they consider their paths for successful aging; decision to initiate hormone therapy should be made after weighing individualized risks against patient's symptom burden and indicated benefits. **It is important to appreciate that the attitude and beliefs of the clinician have a major influence on the treatment-related decisions made by patients.** As beneficial as the impact of hormonal therapy may be, we must also emphasize the large improvement in health to be gained by lifestyle changes in smoking cessation, diet, regular exercise, and control of body weight.

It is the task of an epidemiologist to derive study conclusions based on research data. It is the obligation of a clinician to make a judgment whether the epidemiologist's conclusions have clinical meaning. For example, an epidemiologist may conclude that estrogen reduces coronary artery calcification and point out that a randomized clinical trial has not proved that such a reduction lowers the risk of CHD. But it is appropriate for a clinician, knowing the correlation between coronary artery calcification and CHD, to conclude that estrogen reduction of coronary calcification will translate into less CHD. Medical judgments require more than absolute evidence from randomized trials, and medical judgments frequently do not have the luxury of postponing clinically meaningful decisions until data are conclusive.

Long-term postmenopausal hormone therapy is not precluded by the results reported by the WHI. Protection against osteoporotic fractures, reduction in incidence of colorectal cancers and possibly new-onset diabetes mellitus, and a possibility of primary prevention of CHD are some of the benefits of long-term hormone therapy. Of course, these hormone use-related benefits must be weighed against the known hormone-related risks of VTE, stroke, and breast cancer (from estrogen and progestin use). Considerations must also be given to alternative proven therapies (e.g., statins) and to support beneficial lifestyle modifications. It remains the clinician's responsibility to weigh any purported benefit against hormone therapy-related risks for each patient to ensure that patients are not subjected to undue risks.

## **The WHI Agrees with 30 Years of Research**

- Coronary heart disease: potential for protection in young postmenopausal women

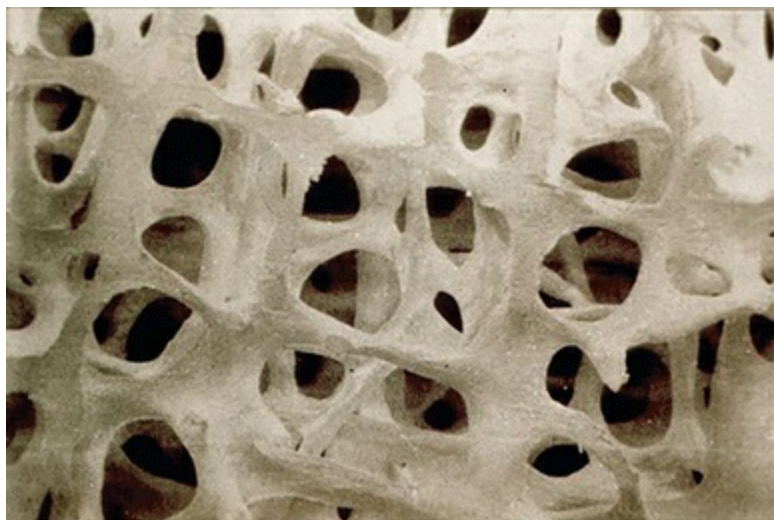
- Stroke: no increase in early postmenopausal, healthy women
- VTE: twofold increase in first years of use, concentrated in those at risk
- Cancer: slightly increased risk of breast cancer or an effect on preexisting tumors; reduction in colorectal cancer
- Osteoporosis: reduction in vertebral and nonvertebral fractures
- Diabetes mellitus: reduction in new-onset diabetes

A theme has emerged from the epidemiologic confusion of the last decade. It takes healthy tissue to allow effective response to estrogen and maintenance of health. Experimental evidence in monkeys and women indicates that as endothelial cells become involved with atherosclerosis and neurons become affected with the pathologic processes, beneficial responses to estrogen diminish.<sup>359,1216,1217</sup> Maximal benefit, therefore, requires early onset of treatment, near the time of menopause.

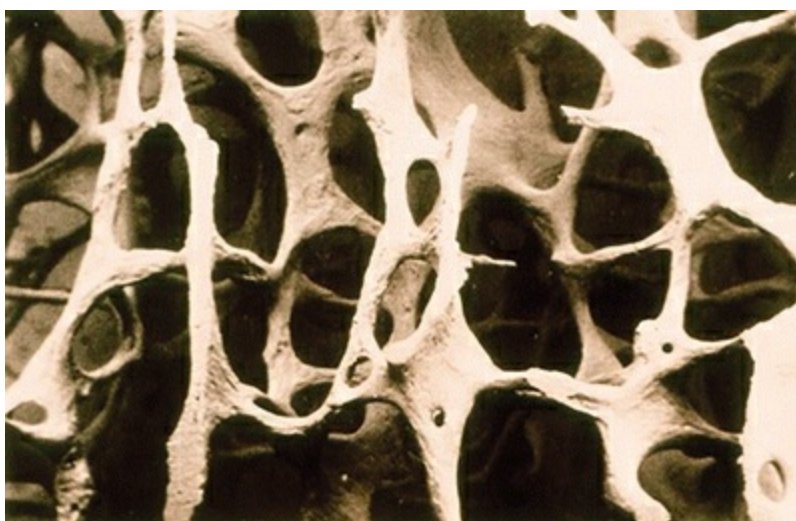
The most effective and appropriate method to help in decision-making is to identify the specific goals and objectives of the individual patient—let your patient be your guide. Once an individual's objectives are identified, choices from multiple treatment options can be reviewed. Postmenopausal health and hormone therapy are subjects receiving enormous attention and research; therefore, decision-making should be at least an annual event, incorporating new knowledge as it appears. Approached in this fashion, the terms “short term” and “long term” and the imposition of time limits for therapy become meaningless. Clinician and patient together make an annual clinical judgment that is appropriately directed to accomplishing the individual patient's goals. **The guiding principle is the right drug in the right dose for the appropriate duration according to an individual patient's needs and tailored to the individual's unique risk profile.**

## OSTEOPOROSIS (FIGURE 17.17A, B)

---



A

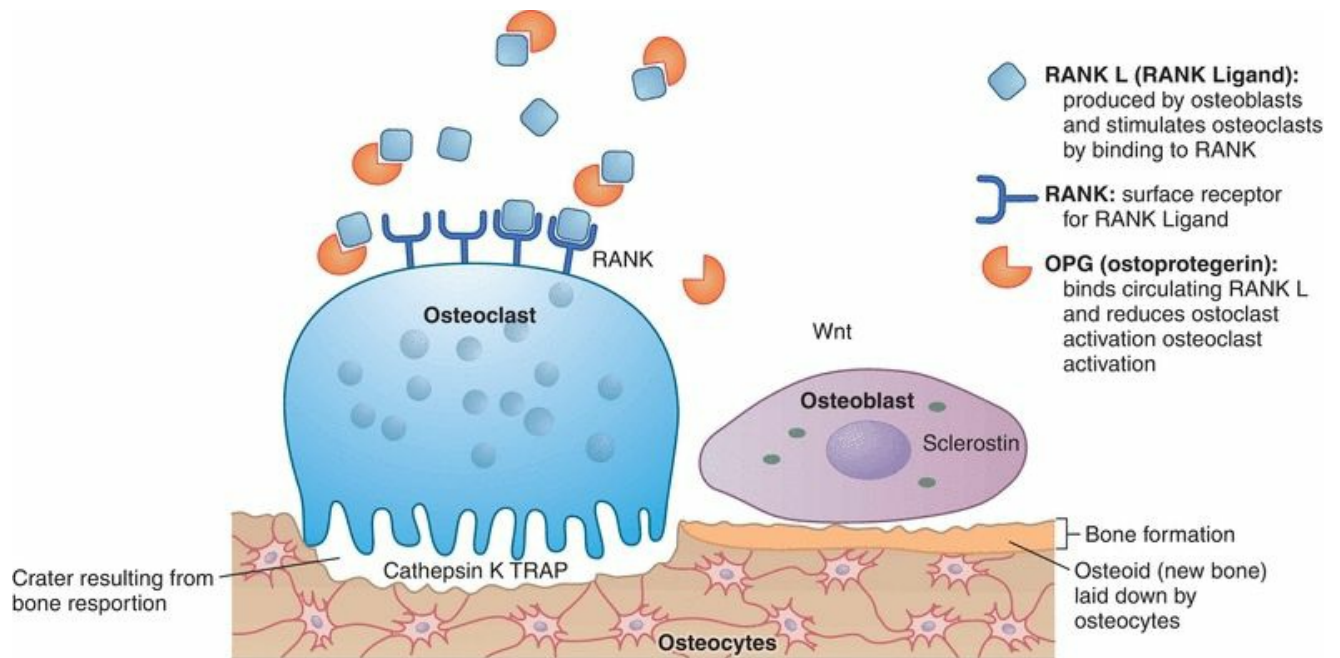


B

**FIGURE 17.18** Normal (A) and osteoporotic (B) bone architecture. Osteoporosis is a disease characterized by **low bone mass** and **microarchitectural deterioration** of bone tissue leading to enhanced bone fragility and a consequent increase in fracture risk. Courtesy of World Health Organization (WHO), 1993.

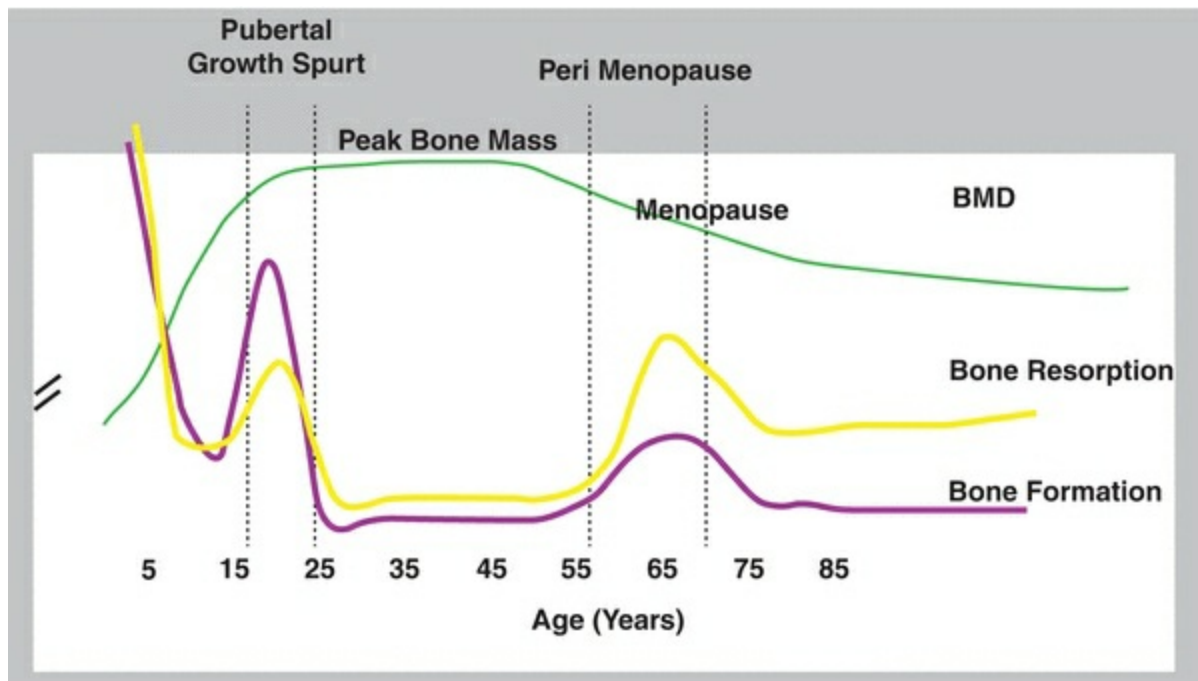
Bone is a very active organ. A continuous process, called bone remodeling, involves constant resorption (osteoclastic activity) and bone formation (osteoblastic activity) (Figure 17.18). Both osteoblasts and osteoclasts are derived from bone marrow

progenitors, osteoblasts from mesenchymal stem cells and osteoclasts from hematopoietic white cell lineage. Cytokines are involved in this development process of bone turnover, which is regulated by the sex steroids. A system of cross talk exists between the bone-forming osteoblasts and the bone-resorbing osteoclasts, with many autocrine, intracrine, and paracrine signals among which RANK-L, OPG (osteoprotegerin), cathepsin, and sclerostin are prominent.



**FIGURE 17.18**

The amount of bone at any point of time reflects the balance of the osteoblastic and osteoclastic forces, influenced by a multitude of stimulating and inhibiting agents. At puberty and during the early reproductive years, net bone gain occurs, whereas aging and a loss of estrogen both lead to a dominance of osteoclastic activity and net bone loss (**Figure 17.19**). A decrease in calcium intake and/or absorption similarly results in bone loss as this lowers the serum level of ionized calcium, resulting in stimulation of parathyroid hormone (PTH) secretion in efforts to mobilize calcium from bone by direct stimulation of osteoclastic activity, a phenomenon known as secondary hyperparathyroidism. Increased PTH also stimulates the hepatic and renal activation of vitamin D in efforts to increase serum levels of calcium through intestinal calcium absorption. A deficiency in estrogen is associated with a greater responsiveness of bone to PTH. Thus, for any given level of PTH when estrogen is deficient, there is more calcium removed from bone, raising serum calcium, which, in turn, lowers circulating PTH and decreases vitamin D and intestinal absorption of calcium.



**FIGURE 17.19**

**Osteoporosis**, the most prevalent bone problem in the elderly, is characterized by both decreased bone mass and decreased bone quality, and both these factors contribute to an increased risk of fragility fractures. Osteoporosis is a major global public health problem threatening more than 44 million individuals, and it is epidemic in the United States, affecting 10 million Americans (4 times more women than men).<sup>1719</sup> In addition, about 34 million people (80% women) in the United States have low bone mass (osteopenia), and they too are also at an increased fracture.

The increase in osteoporotic fractures in the developed world is partly due to an increase in the elderly population, but not totally. A comparison of bone densities in proximal femur bones in specimens from a period of over 200 years suggested that women lose more bone today, perhaps due to less physical activity and less parity.<sup>1720</sup> Other contributing factors include a dietary decrease in calcium and an earlier and greater loss of bone because of the impact of smoking. Our Stone Age predecessors consumed a diet high in calcium, mostly from vegetable sources.<sup>1721</sup> However, the impact of the tremendous increase in the elderly population throughout the world cannot be underrated. Because of this demographic change, the number of hip fractures occurring in the world each year will increase approximately sixfold from 1990 to 2050.<sup>1722</sup>

# Pathophysiology of Osteoporosis

Osteoporosis is characterized by low bone mass and microarchitectural deterioration of bone tissue, leading to enhanced bone fragility and a consequent increase in the risk of fractures even with little or no trauma. The skeleton consists of two bone types. Cortical bone (the bone of the peripheral skeleton) is responsible for 80% of total bone, while trabecular bone (the bone of the axial skeleton—the spinal column, the pelvis, and the proximal femur) constitutes a honeycomb structure filled with red marrow and fat, providing greater surface area per unit volume.

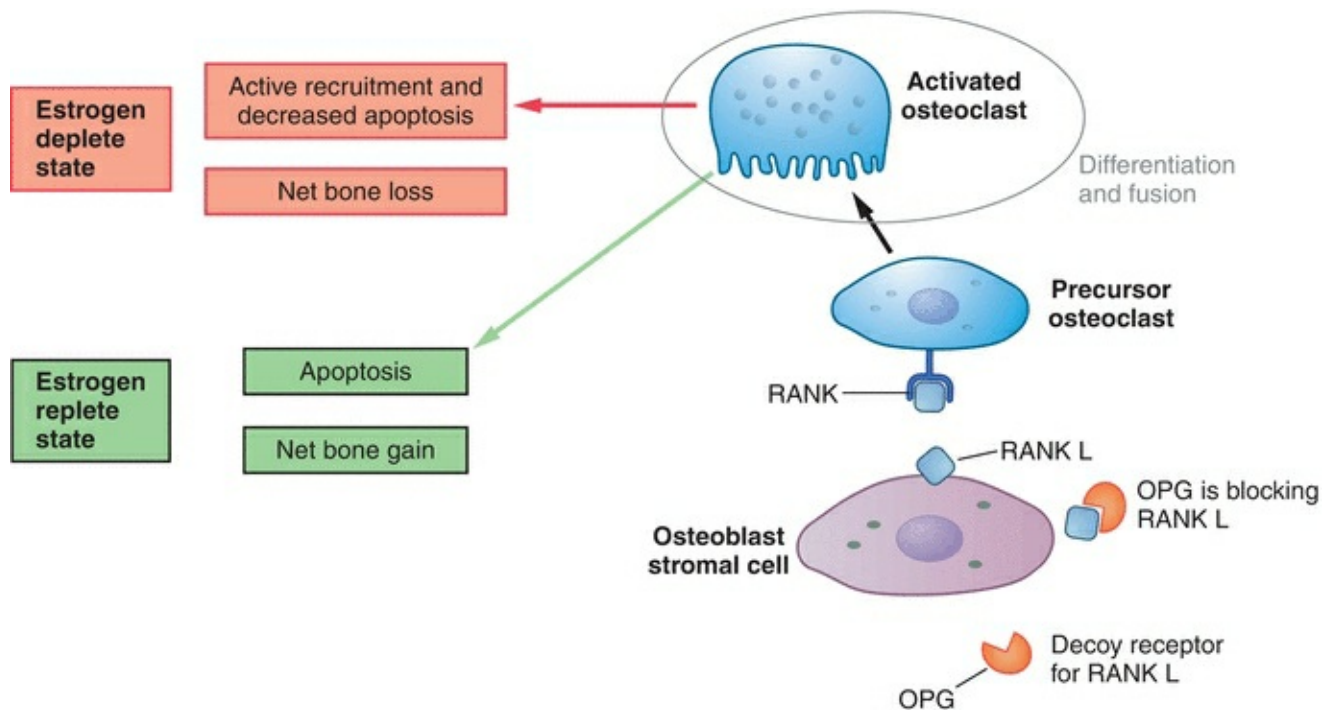
**The subsequent risk of fracture from osteoporosis in women will depend on bone mass at the time of menopause and the rate of bone loss following menopause.**<sup>1723</sup> The peak bone mass is influenced by heredity and endocrine factors, among which estrogens are particularly relevant. It is now recognized that there exists only a relatively narrow window of opportunity for maximizing bone mass. Almost all of the bone mass in the hip and the vertebral bodies is accumulated in young women by late adolescence (age 18), and the years immediately following menarche (11–14) are especially important.<sup>1724,1725,1726</sup> **Estrogen exposure during adolescence is vital to bone mass accrual.** Individuals who experience a late menarche are characterized by bones with lesser density and a reduction in microstructural components, a bone quality that persists to menopause and is associated with an increased risk of fractures.<sup>1727</sup> Women who experience amenorrhea during adolescence have an increased prevalence of osteoporosis.<sup>1728</sup> Calcium supplementation in prepubertal and pubertal girls improves bone accrual, an important effect that could have long-lasting beneficial consequences.<sup>1729,1730,1731,1732</sup>

Although the onset of spinal bone loss begins in the 20s, the overall change is small until periods of menopause transition and early menopause.<sup>1725,1733</sup> Bone density in the femur peaks in the mid to late 20s and begins to decrease around age 30. In general, trabecular bone resorption and formation occur 4 to 8 times as fast as cortical bone. Beyond age 30, trabecular resorption begins to exceed formation by about 0.7% per year. Bone loss accelerates after menopause as up to 5% of trabecular bone and 1–1.5% of total bone mass loss occurs per year in the first years after menopause. This accelerated loss continues for about 5 years, after which bone loss rate is considerably diminished but continues as the aging-related loss.<sup>1734</sup> For the first 20 years following cessation of menses, post-menopause-related bone loss results in as much as 50% reduction in trabecular bone and a 30% reduction in cortical bone.<sup>1735,1736</sup>

**When estrogen levels decline, bone remodeling, resorption, and formation increases.** The site of maximal bone remodeling is determined by a need to adapt to physical loads on the skeleton. Each remodeling locus is initiated by osteoclast-



mediated reabsorption and excavation of old bone, a process that takes 3–5 months, followed by osteoblast-mediated restoration and refilling. In reproductive years, the processes of bone resorption and bone formation are well balanced with resultant maintenance of net bone mass. Estrogen exerts a tonic suppression of remodeling by directing activated osteoclasts toward apoptosis and maintains a balance between osteoclastic and osteoblastic activity; in the absence of estrogen, osteoclastic activity predominates, resulting in net bone resorption. The precise mechanism of action for sex steroid protection of bones remains unknown; however, a growing body of knowledge indicates complex interactions at the molecular level, with both a classic pathway involving genomic transcription by hormone receptors and a nongenomic pathway that inhibits apoptosis (Figure 17.20).<sup>1737,1738</sup> Increased efficiency of calcium absorption, probably secondary to estrogen-induced enhancement of the availability of vitamin D, and a direct role for the estrogen receptors in the osteoblasts are likely important factors. Many estrogen-dependent growth factors and cytokines are involved in bone remodeling.<sup>1739,1740</sup> Estrogen modulates the production of bone-resorbing cytokines such as interleukin-1 and IL-6, bone-stimulating factors such as insulin-like growth factor-I, colony-stimulating factor, OPG, and proteins that are members of the transforming growth factor- $\beta$  family.<sup>1741</sup> Estrogen increases vitamin D receptors in osteoblasts, and this may be a method by which estrogen modulates vitamin D activity in bone.<sup>1742</sup> There is little evidence that estrogen affects bone by altering the circulating calcitropic hormones.<sup>1743</sup> Thus, the actions of estrogen are primarily direct effects on bone and important effects on vitamin D metabolism and renal and intestinal handling of calcium.



## FIGURE 17.20

Estrogen is a critical hormone for skeletal health in both males and females. Males with mutations in the estrogen receptor-alpha or who have aromatase deficiencies grow slowly and have markedly reduced bone densities.<sup>1744,1745</sup> Analysis of the decline in testosterone and estrogen circulating levels with aging indicates that the amount of bioavailable estrogen circulating in the blood is the most consistent predictor of bone density in men and women.<sup>1746</sup> And most impressively, men with an aromatase deficiency, treated with estrogen, demonstrated that both androgens and estrogens are necessary in order for males to reach optimal bone mass.<sup>1747,1748</sup>

Racial differences in bone mass are well recognized. Bone mass, adjusted for body size, is greater in the black compared to white populations. It is believed that racial differences in bone density are established in childhood and early adolescence.<sup>1749,1750</sup> More than half the difference, comparing black children with white children, is due to differences in body size and composition; a significant contribution is made by bone metabolism, a smaller portion by sex hormone levels, and only 2% of the difference is unexplained.<sup>1751</sup> During adolescence, blacks absorb calcium more efficiently and bone turnover is greater with more net bone formation.<sup>1752</sup>

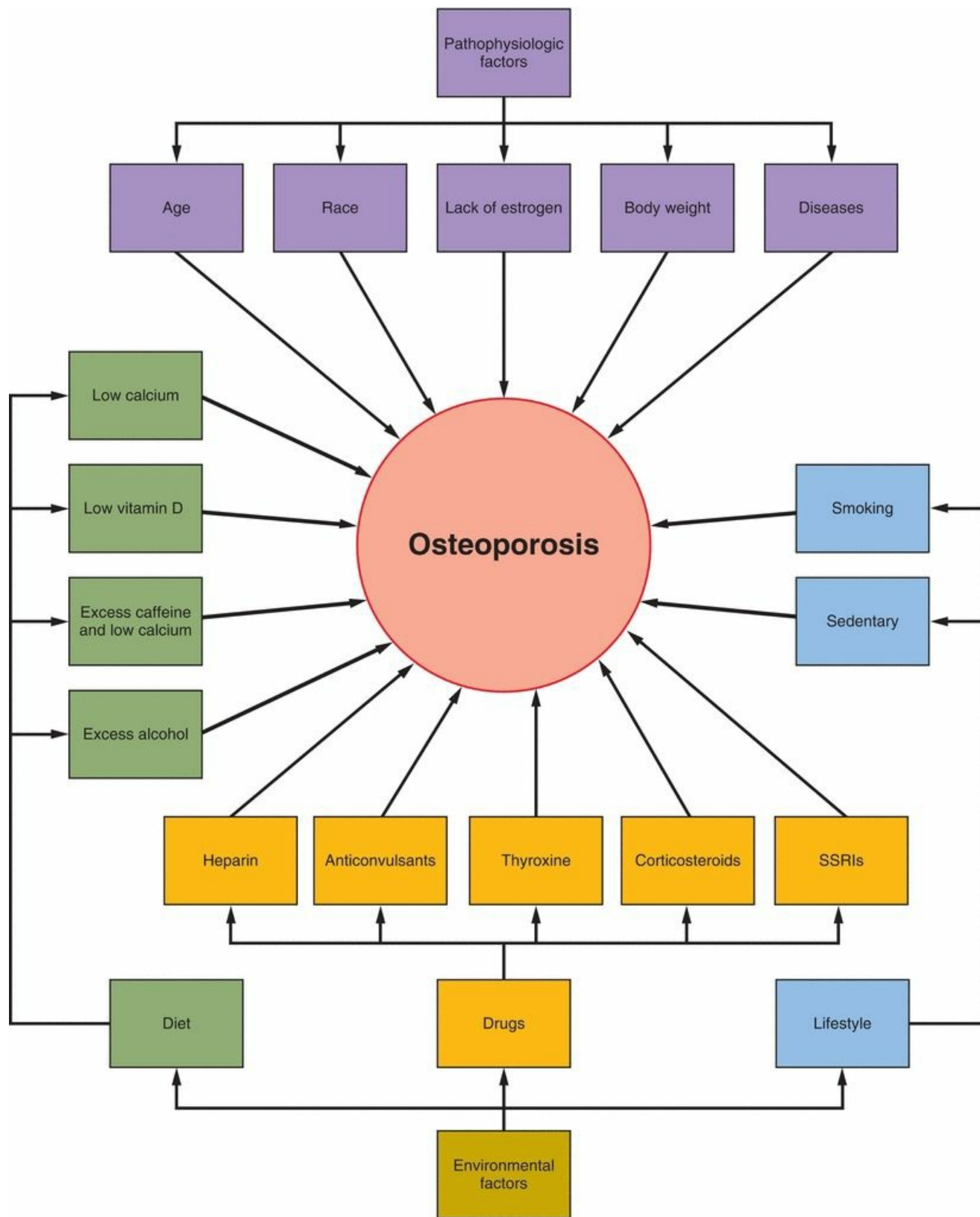
In general, bone mass is greater in black and obese women and less in white, thin, and sedentary women. Spinal bone density is similar among black and Asian women (lower in white women), and hip bone density is higher among blacks compared to white and Asian women.<sup>1753</sup> Conventional wisdom has held that Asian women have even lower bone densities than white women. The SWAN study demonstrated that this apparent difference disappeared when the data were adjusted for body size.<sup>1753,1754</sup> Both black and Asian women have higher bone density and lower fracture rates than white women. Despite the greater bone mass and lower fracture rates, the impact of osteoporotic fractures in black and Asian women is still considerable. Postmenopausal estrogen therapy is associated with improved BMD and protection against fracture risk regardless of race.<sup>1755</sup> Japanese women demonstrate the same amount and pattern of bone loss after menopause as white women.<sup>1756</sup>

Although estrogen plays a principal role in regulating bone density, genetic susceptibility for low bone mass and for bone loss are important. A study of the premenopausal daughters of women with osteoporosis revealed a reduction in bone mass, suggesting genetic influence as well as the sharing of a lifestyle that may contribute to a relatively low peak bone mass.<sup>1757</sup> **Studies of twins and mother-daughter pairs indicate that up to 70% of the variation in bone density is**

**determined by heredity.**<sup>1758</sup>

Variations in the gene that encodes the vitamin D receptor are prevalent in postmenopausal women with decreased bone densities.<sup>1759</sup> The absence of vitamin D receptor gene allelic polymorphisms was reported in older women who neither lose significant bone nor respond to calcium supplementation.<sup>1760</sup> The inherited aspects of osteoporosis are likely to be influenced by multiple susceptibility genes. For example, low bone density is associated with specific alleles of COL1A1, 1 of the 2 genes that encode the 2 polypeptides of collagen.<sup>1761</sup> Two single nucleotide polymorphisms, variants for key biologic proteins (the OPG and lipoprotein-receptor-related genes) are present in slightly over 20% of white people and are associated with an increased risk for osteoporosis.<sup>1762</sup> Clarity on genetic markers to identify individuals at increased risk for osteoporosis is still lacking and informative yield of existing efforts is, at best, limited.

The accelerated loss of bone in postmenopausal women is largely attributed to estrogen loss; 75% or more of the bone loss that occurs in women during the first 15 years after menopause is due to estrogen deficiency rather than to aging itself.<sup>1763,1764</sup> Vertebral bone is especially vulnerable, beginning to decline as early as 20 years of age.<sup>1765</sup> Vertebral bone mass is significantly decreased in perimenopausal and early postmenopausal women who have rising FSH and decreasing estrogen levels, whereas bone loss from the radius is not found until at least a year out from the menopause.<sup>1766</sup> This early loss of axial skeleton suggests that the hypoestrogenic postmenopausal state is not the only cause of vertebral osteoporosis.<sup>1767</sup> One obvious suspect is a decline in dietary intake of calcium and vitamin D in the premenopausal years; nevertheless, menopause and the loss of estrogen remain as the major contributors to bone loss. The risk of fracture, therefore, depends on 2 factors: the bone mass achieved at maturity and the subsequent rate of bone loss. **A high rate of bone loss after menopause (the “fast loser”) is highly predictive of an increased risk of fracture.** The combination of a low bone mass and fast losing is additive, and thus, these individuals are at the highest risk of fracture. Fast losing probably reflects lower endogenous estrogen levels. The bone density, which is the threshold for vertebral fractures, is only slightly below the lower limit of normal for premenopausal women.<sup>1768</sup> **Figure 17.21** outlines the various factors contributing to osteoporosis.



**FIGURE 17.21**

# Bone Loss During the Menopausal Transition

Should a clinician be concerned about bone loss and consider interventions during the perimenopausal years? A decline in BMD, as well as up-regulation of circulating and urinary levels of CTX (C-telopeptide), a marker representing degradation of bone collagen, are apparent in the menopause transition, well before the FMP. Some studies concluded that calcium supplementation of perimenopausal women retards metacarpal and lumbar bone loss.<sup>1769,1770</sup> Perimenopausal women in the SWAN study demonstrated decreasing bone densities that correlated with increasing FSH levels; however, accelerated bone loss did not occur until late in the perimenopause.<sup>1754</sup> The amount of perimenopausal bone loss is small unless estrogen levels are below normal.<sup>1771,1772,1773,1774</sup> Unlike those in perimenopause (discussed earlier in this chapter), otherwise healthy women who are anovulatory or those who demonstrate inadequate luteal phase ovarian function (and thus are exposed to less progesterone) but are not hypergonadotropic, do not have an increase in bone loss.<sup>1775,1776</sup> **Bone loss in the perimenopausal period is unlikely to be clinically consequential for the majority and interventions and treatments to prevent future osteoporosis are not necessary in perimenopausal women who have adequate estrogen levels and who are eating normally.** However, those who had failed to attain optimal peak bone mass in their younger years, an earlier onset of bone loss in the menopause transition may contribute toward an enhanced lifetime fracture risk; such women will benefit from an individualized risk assessment and consideration of timely initiation of antifracture interventions (discussed later in this chapter).

# Signs and Symptoms of Osteoporosis

Fragility fracture is a fracture that results from minimal trauma, or from a person falling from a standing height. Fragility fractures are the most common consequence of osteoporosis and commonly involved anatomical sites are the humerus, upper femur, distal forearm, and ribs. Osteoporosis is recognized as a “silent disease” that in the absence of targeted screening, may only present itself once the affected individual sustains a fracture. Osteoporosis is responsible for more than 2 million fractures per year in the United States.<sup>1719</sup> About one in two white women over age 50 will experience an osteoporosis-related fracture. Lack of estrogen and advancing age are both causative to the cumulative fracture burden of postmenopausal years. Back pain is a major clinical symptom of vertebral compression fractures. The pain with a fracture is acute, and then it decreases over 2–3 months, but lingers as chronic low back pain due to increasing lumbar lordosis. The pain subsides within 6 months unless multiple fractures produce a picture of constant pain. **Many individuals will not know they have osteoporosis until they experience a fracture.** Loss of height, kyphosis, decreased mobility and even respiratory compromise and worsening constipation are recognized disabilities resulting from fractures of the thoracolumbar spine.

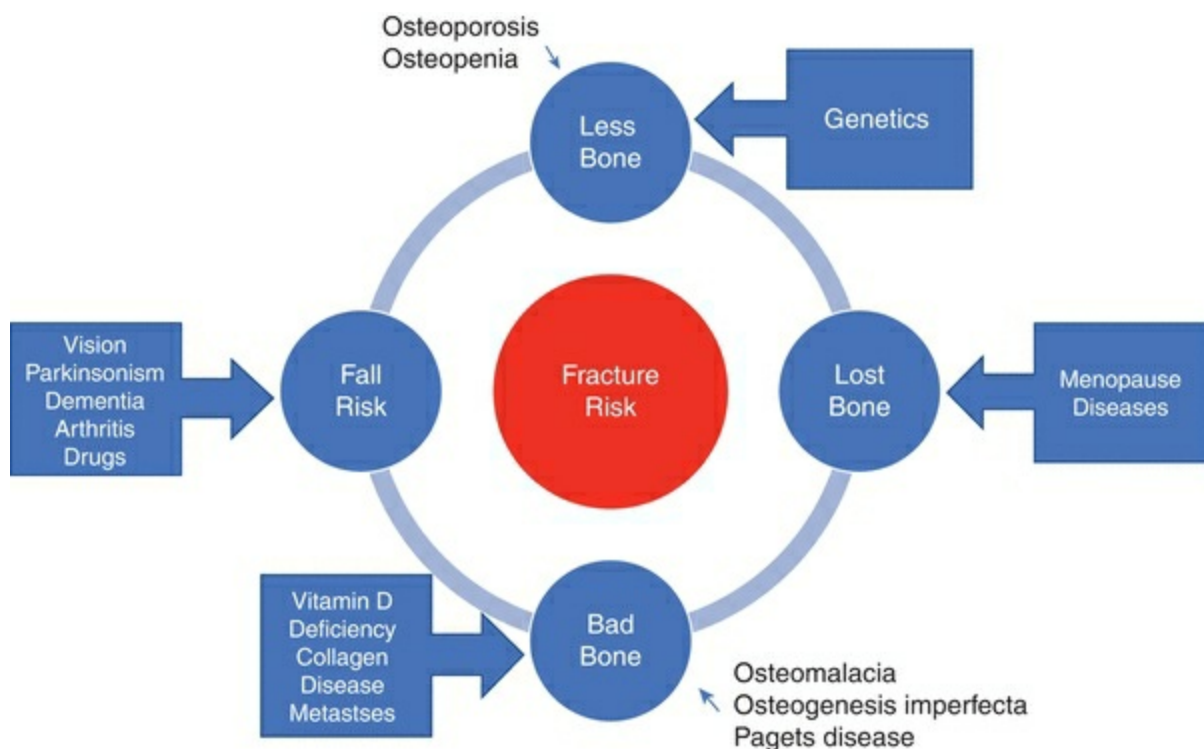
**Epidemiologic studies have revealed the following<sup>1777,1778</sup>:**

- 1. Spinal (vertebral) compression fracture.** Symptomatic spinal osteoporosis, causing pain, loss of height, postural deformities (the kyphotic dowager’s hump) with consequent pulmonary, gastrointestinal, and bladder dysfunction, is 5 times more common in white women than men. Approximately 50% of women over 65 years of age have spinal compression fractures; about two-thirds are clinically unrecognized. **Each complete compression fracture of a vertebral body causes the loss of approximately 1 cm in height.** The average untreated postmenopausal white woman can expect to shrink 2.5 inches (6.4 cm). The most common sites for vertebral fractures are the 12th thoracic and the first three lumbar vertebrae. These physical changes also have a negative impact on body image and self-esteem.
- 2. Colles fracture.** There is a 10-fold increase in distal forearm fractures in women as they progress from age 35 to 60 years. White women are more predisposed to wrist fracture than those of other races; a white woman has approximately a 15% lifetime risk of a forearm fracture. Colles fractures are the most common fractures among women until age 75, when hip fractures become more common.
- 3. Head of femur fracture.** The incidence of hip fractures increases with age in women, rising from 0.3/1,000 to 20/1,000 in white women between 45 and 85 years of age. **Eighty percent of all hip fractures are associated with osteoporosis.** White women who are 50 years old have approximately a 14%

lifetime risk of having a hip fracture; black 50-year-old women, 6%. **Hip fracture carries an increased risk of morbidity and mortality.** About 25% of patients over the age of 50 with hip fractures die due to the fracture or its complications (surgical, embolic, cardiopulmonary) within 1 year. The survivors are frequently severely disabled and may become permanent invalids. Hip fractures alone occur in about 300,000 individuals per year in the United States with a mortality of 40,000 annually and an associated cost of billions of dollars.<sup>1719</sup>

- 4. Tooth loss.** Oral alveolar bone loss (which can lead to loss of teeth) is strongly correlated with osteoporosis, and the salutary effect of estrogen on skeletal bone mass is also manifested on oral bone.<sup>1667,1779</sup> Even in women without osteoporosis, there is a correlation between spinal bone density and number of teeth.<sup>1668</sup> Tooth loss is also correlated with the use of cigarettes, a recognized contributor to bone loss. Long-term use of postmenopausal hormone therapy has been linked with fewer lost teeth.<sup>1780,1781,1782</sup>

**Individuals at an increased risk for fracture can be identified by a careful history and examination (Figure 17.22).**



**FIGURE 17.22**

**The following risk factors are especially important for women:**

- **Aging: the risk of fracture doubles every 7–8 years after age 50.**
- **Previous history of a fragility fracture.**
- **Family history of fragility fracture, particularly in first-degree relatives.**
- **Smoking.**
- **Low body weight, being small-framed and thin.**
- **Family history of osteoporosis, particularly if in first-degree relatives.**
- **Prolonged amenorrhea (hypoestrogenism).**
- **Lifelong deficient calcium and vitamin D intake.**
- **Use of bone-losing medications, such as oral steroids.**
- **Sedentary lifestyle.**
- **Excessive use of alcohol.**
- **Rheumatoid arthritis.**

Postmenopausal women who have already experienced a vertebral fracture deserve aggressive intervention. The risk of subsequent, additional vertebral fractures is substantial; 20% of women experience another vertebral fracture within 1 year after the first fracture.<sup>1783</sup> These women are also at increased risk for nonvertebral fractures.<sup>1784,1785</sup> **A complete evaluation for osteoporosis is an essential component of care for a patient presenting with a fragility fracture; as defined by the World Health Organization, a fragility fracture is one that results from an injury that would be insufficient to break a normal bone. All osteoporotic fractures are associated with an increased risk of mortality that persists for 5–10 years after the fracture.**<sup>1786</sup>

Because there are so many women with osteoporosis, a greater prevalence of depression in this population would amount to a clinical problem of considerable proportions. A cross-sectional subset in a large clinical trial reported a greater prevalence of depressive symptoms in women with fractures.<sup>1787</sup> It is well recognized that fractures secondary to osteoporosis are accompanied by a reduction in psychological and physical well-being. As far as depression goes, it is difficult to know which came first, depression or fractures, leading to subsequent depression. It has been reported that depressed people have a greater incidence of falls,<sup>1788</sup> and thus it is not unreasonable to consider that depression comes first in some people. Furthermore, depressed people are sedentary and eat poorly, factors that favor bone loss. It is speculated that chronically increased cortisol levels associated with depression might contribute to bone loss, similar to that observed with the pharmacologic administration of glucocorticoids. On the other hand, a cohort study of American women, despite finding a link between depression and fractures, failed to detect an increase in depression associated with lower bone density measurements.<sup>1788</sup> However, other studies have reported increases in depression associated with lower bone



densities.<sup>1789,1790,1791</sup>

Bone loss has been documented in an established rodent model for stress-induced depression, characterized by a decrease in osteoblastic bone formation that can be attenuated by an antidepressant drug.<sup>1792</sup> In this experimental model, osteoblastic inhibition was mediated by stress-induced stimulation of the sympathetic nervous system. Although this response is associated with an increased secretion of adrenal glucocorticoids, the evidence also indicates a direct role for sympathetic fibers in bone.

**We need to be aware that women who have experienced fractures may have depressive symptoms, and appropriate interventions can have a beneficial impact on quality of life. The important point is that depression and fractures are linked and attention to psychological well-being should be an integral part of management of individuals who have experienced fragility fractures as each condition can impact the course of the other in different patients, and both directly impact on the quality of life in all affected individuals.**

Selective serotonin reuptake inhibitors (SSRIs) are the favored treatment for depression in older adults, a problem that affects about 10% of the older population. Several earlier studies had reported an increased risk of fractures with the daily use of SSRIs; however, these earlier studies were unable to control for the various factors that influence this risk, especially falls, depression, and bone density. An excellent prospective cohort study in Canada indicated that the increase in fractures persisted after controlling for these factors.<sup>1793</sup>

There is a direct effect of SSRIs on bone. Components of the neural system are involved in bone metabolism, and serotonin receptors and serotonin transport have been identified in osteoblasts and osteocytes. The bone effects of parathyroid hormone and mechanical stimulation are modulated by the serotonin system. Mice with a mutation for the serotonin transporter develop less bone mass and strength.<sup>1794</sup> Therefore, daily SSRI use can impair bone formation, tilting the balance in favor of resorption and bone loss; indeed, decreased bone densities have been reported in both male and female SSRI users (but not in users of tricyclic antidepressants).<sup>1795,1796</sup>

# Measuring Bone Mineral Density

There is a 50–100% increase in fracture risk for each standard deviation decline in bone mass (approximately 0.1 g/cm bone mass).<sup>1797</sup> Evidence of lower bone mass at the hip is even more predictive of fracture risk; lesser bone mass one standard deviation at the hip has been associated with nearly a threefold increase in risk of fracture.<sup>1798</sup>

**Although low bone density reliably predicts the risk of fracture, increases in bone density in response to treatment do not demonstrate a direct correlation with a reduction in fractures. Therefore, a few percentage point differences achieved by various treatments may have little clinical meaning.**

The impressive correlation between fracture risk and low bone density has raised the question of whether it is of value to screen for osteoporosis. Keep in mind that because the rate of bone loss after menopause contributes equally to the risk of fracture as the total bone mass present at the time of the menopause, a normal bone density measurement at the time of menopause does not mean that the patient will not be at risk of fracture later in life. A relatively young woman with a low bone mass could be targeted for appropriate intervention; however, it is not cost-effective to attempt to screen all postmenopausal women with an expensive method, and attention is now returning to the methods of single-photon, single-energy x-ray absorptiometry and ultrasonography because measurement of bone loss at the heel, the metacarpal, and the radius using these simpler technologies can provide accurate assessment of future fracture risk.<sup>1799</sup>

Bone density measurements are certainly useful when the information will facilitate an individual to make an informed decision regarding initiating specific treatment, such as postmenopausal hormone therapy. Indeed, a decision to use hormone therapy and better maintenance of a hormone program are correlated with patients' knowledge of their bone density measurements.<sup>1800,1801</sup> In the United States, multiple organizations including the American College of Obstetricians and Gynecologists (ACOG) (2004), the U.S. Preventive Services Task Force (USPSTF), and the National Osteoporosis Foundation (NOF) are unified in their recommendations that in the absence of risk factors, postmenopausal women should be offered screening for osteoporosis by DEXA starting at age 65; earlier screening should be considered in those with risk factors especially if results of bone density test can help determine the course of management. Patients who have received long-term corticosteroid, thyroxine, anticonvulsant, or heparin treatment warrant bone mass assessment earlier than age 65. **After an initial assessment of bone density, decision to perform repeat measurements should be individualized based on results of the initial test and tailored to the patient's clinical picture;** for the majority, repeat bone density measurements to monitor bone

loss can be considered at every 2- to 5-year intervals.

## Key Points: Reasons to Measure Bone Mass

- To help patients make decisions regarding hormone therapy
- To assess response to therapy in selected patients, for example, smokers, and women with eating disorders
- To assess bone mass in patients being treated long term with glucocorticoids, thyroid hormone, anticonvulsants, or heparin
- To confirm the diagnosis and assess the severity of osteoporosis to aid in treatment decisions and to monitor efficacy of therapy
- To assess bone mass in postmenopausal women who present with fractures, who have one or more risk factors for osteoporosis, or who are over age 65
- Recording standing height will detect any decrease that should raise concerns regarding possibility of underlying osteoporosis
- Bone mass should be measured in postmenopausal women who present with fractures, who have one or more risk factors for osteoporosis, or who are over age 65

Standard x-rays do not provide an early assessment of fracture risk; 30–40% of bone must be lost before radiographic changes become apparent. Photon absorptiometry measures the transmission of photons through bone. Single-photon absorptiometry uses a <sup>131</sup>I source of energy or, more recently, miniature x-ray tubes. These methods can reliably measure bone density in the radius and the calcaneus and are relatively inexpensive. These measurements correlate with vertebral bone density and predict the risk of future fracture, particularly in older women.<sup>1799</sup> Dual-energy absorptiometry employs different photons from two energy sources. Dual-energy x-ray absorptiometry (DEXA) provides good precision for all sites of osteoporotic fractures, and the radiation dose is much less than for a standard chest x-ray. Whole-body scans by DEXA can measure total body calcium, lean body mass, and fat mass. **DEXA remains the gold standard technology for bone density measurement in routine clinical practice.** Quantitative CT for bone density measurements can be performed on most commercial computed tomography systems; however, radiation exposure is higher than with DEXA, and measurements of the femur are not available, although very accurate measurements of the spine are possible.

For high precision, the best information is provided by the DEXA technique (together with sophisticated software to give a precision of 1%), measuring the three

sites of greatest interest, the radius, the hip, and the spine.<sup>1802</sup> Better accuracy is gained by three-site assessments because there can be differences among the anatomical sites. In other words, a normal value at one site does not preclude a low bone density at another site. For practical clinical use (and for screening), measurements are made at the lumbar spine, the hip, and the femoral neck. Serial measurements are best made at least 2 years apart to allow meaning interpretation of interval data. Measurement of the bone density at the radius or calcaneus is more cost-effective, using single-source x-ray absorptiometry, and can be used for screening. It is anticipated that ultrasonography will prove to be a low-cost, effective method for bone mass assessment, particularly in high-risk populations.<sup>1803</sup> Ultrasonographic measurements of the calcaneus have been reported to be as accurate as femoral neck measurements by DEXA in predicting the risk of hip fractures.<sup>1804,1805</sup> However, peripheral measurements are not accurate for monitoring response to treatment.

## Terminology (Table 17.15)

**TABLE 17.15 Definitions Based on Bone Mineral Density**

Normal	0 to $-1$ SD from the T-score reference standard (84% of the population)
Osteopenia	T-score between $-1$ and $-2.5$ SD
Osteoporosis	T-score at or below $-2.5$ SD

- **T-score:** Standard deviations between patient and average peak young adult bone mass. The more negative, the greater the risk of fracture.
- **Z score:** Standard deviations between patient and average bone mass for same sex, age, and ethnicity.

In postmenopausal women, fracture risk assessment based on DEXA depends on interpretation of the T-score (i.e., how her bone mass compares to that of a young skeleton) (see Table 17.15). In contrast to postmenopausal women, interpretation of bone density measurement in premenopausal woman should be based on the Z

score (i.e., how her bone mass compares to her age- and sex-matched healthy individuals in the population). In postmenopausal women, T-scores of less than or equal to  $-2.5$  are consistent with a diagnosis of osteoporosis, whereas in premenopausal women, Z scores of equal to or less than  $-2.0$  reflect low bone mass and identify premenopausal women who are at risk for future fracture. A bone density Z score that is lower than  $-2.0$  (2.5% of normal population of same age) at any age should prompt consideration for diagnostic evaluation for potential causes of bone loss.

# Diagnostic Tests

Patients with osteoporosis should be screened for underlying conditions that can lead to bone loss:

1. Serum parathyroid hormone, calcium, phosphorus, and alkaline phosphatase: for primary hyperparathyroidism
2. Renal function tests: for secondary hyperparathyroidism with chronic renal failure
3. Serum 25-hydroxyvitamin D: for vitamin D deficiency
4. Thyroid function tests: for hyperthyroidism and excessive thyroid hormone treatment
5. Blood count and smear, sedimentation rate, and protein electrophoresis: for multiple myeloma, leukemia, or lymphoma
6. Careful history and, when indicated, appropriate laboratory studies to rule out long-term use of bone-losing medications, alcohol abuse, metastatic cancer, and chronic liver disease

Excess thyroxine treatment can cause bone loss. However, retrospective studies of thyroid function and bone mass have not produced uniform conclusions.<sup>1806</sup> In the Study of Osteoporotic Fractures, women with a previous history of hyperthyroidism had an increased risk of subsequent hip fractures, and women taking thyroid hormone also had an increased risk of fracture (which did not reach statistical significance).<sup>1807</sup> However, in a prospective assessment of TSH levels in the Study of Osteoporotic Fractures, no association could be detected between low TSH and bone loss.<sup>1808</sup> A recent meta-analysis provides evidence of increased fracture risk for the spine, hip, and wrist in both subclinical hyperthyroidism and subclinical hypothyroidism.<sup>1809</sup> **It is thus prudent to screen for thyroid dysfunction in postmenopausal women with osteoporosis as well as those with osteopenia and maintain TSH levels within the normal range.**

## Should Osteopenia Be Treated?

The term “low bone mass” is now preferred to the older term “osteopenia,” as defined by bone density T-scores between  $-1.0$  and  $-2.5$ . Approximately 40% of American postmenopausal women have bone densities in the range of osteopenia. It is logical to expect a continuum of fracture risk extending from normal bone density to osteoporosis, and a longitudinal American study observed that osteopenia was associated with a 1.8-fold higher rate of fracture (compared with a 4-fold higher rate with osteoporosis).<sup>1810</sup> Experts argue, however, that most women with osteopenia simply have lower than average bone mass but will not have progressive bone loss and, in the absence of risk

factors, may not require any bone-specific interventions beyond lifestyle modifications that include attention to diet, calcium and vitamin D intake, and weight-bearing exercise. Consideration for treatment depends on the demonstration of continued bone loss as determined by declining bone density on serial measurements. **We support preventive drug therapy for postmenopausal women with evidence of low bone mass in the presence of one or more risk factors for fracture or documented progressive bone loss.**

## **FRAX, the World Health Organization Fracture Risk Assessment Tool**

The World Health Organization fracture risk assessment tool, FRAX, is updated and calibrated according to risk in different geographic areas. This tool is available online for free use from the National Osteoporosis Foundation ([http://www.nof.org/frax\\_update.htm](http://www.nof.org/frax_update.htm)) or directly from the FRAX website (<http://www.shef.ac.uk/FRAX/>).<sup>1811,1812</sup> This algorithm predicts the likelihood for an older individual to experience a fragility fracture over a period of 10 years because of low bone mass. The National Osteoporosis Foundation concluded that treatment is cost-effective if FRAX predicts a 10-year hip fracture probability of at least 3% or an overall risk of any osteoporotic fracture greater than 20%.<sup>1813</sup> The clinical application of FRAX produces no major changes in already-existing guidelines.<sup>1814</sup> An osteoporotic bone density and historical risk factors continue to be important factors indicating the need for treatment. **FRAX is useful in identifying which individuals with osteopenia merit treatment;** nevertheless, a careful evaluation of risk factors as reviewed in this chapter continues to be a reliable method to indicate fracture risk in an individual with low bone mass. For example, long-term use of corticosteroid or treatment with aromatase inhibitors (e.g., in the management of postmenopausal breast cancer) identifies individuals in whom bone loss prevention should be considered regardless of the bone density. In addition, fracture risk calculation by FRAX utilizes bone density at the hip, but not at the spine. The decision to initiate antifracture treatment as well as choice of treatment in a patient with low bone density at the spine but with normal hip bone density requires careful consideration of the individual's history and risk factors. FRAX does not replace good medical judgment. **We support preventive drug therapy for postmenopausal women with evidence of low bone mass and a 10-year hip fracture probability of 3% or higher or a 10-year fracture probability of 20% or higher for any osteoporosis-related fracture according to FRAX.**

## **Biochemical Markers of Bone Turnover**

There are many serum and urinary biochemical markers of bone turnover (see [Table 17.16](#)). Some of the biomarkers (such as hydroxyproline, pyridinoline, and deoxypyridinoline cross-links of collagen, telopeptides of collagen, and serum cross-linked telopeptides) reflect the activity of the osteoclasts, whereas others (such as osteocalcin, bone-specific alkaline phosphatase, and procollagen peptide) reflect the activity of the osteoblasts.

## **Table 17.16 Bone Turnover Markers**



## Bone Resorption Markers

## Bone Formation Markers

### Urinary

- Hydroxyproline
- Pyridinoline (PYD)
- Deoxypyridinoline (DPD)
- N-telopeptide (NTX)
- C-telopeptide (CTX)

### Serum

- CTX
- Bone sialoprotein (BSP)
- Tartrate resistant acid phosphatase (TRAP)

### Serum

- Alkaline phosphatase
- Bone-specific alkaline phosphatase
- Osteocalcin
- Type 1 procollagen
  - C1NP
  - P1NP

The urinary tests use a second-morning voided urine specimen, and the immunoassays measure hydroxyproline, pyridinoline, deoxypyridinoline, the collagen cross-linked N-telopeptides, or the collagen cross-linked C-telopeptides.<sup>1815</sup> These are structural proteins released by osteoclastic resorption of bone. **A measurement of bone turnover markers provides a snapshot in time of the current state of bone metabolism.** Because of individual variability, marker measurements correlate poorly with BMD; however, changes in these markers quickly indicate responses to therapy.<sup>1816</sup> Therefore, it has been proposed that efficacy of therapy (with either hormones or other antiresorptive agents) can be judged by comparing a baseline value with a single follow-up measurement after 1–3 months of treatment.<sup>1817</sup> A lesser decrease in the serum or urinary cross-linked peptides indicates a less than optimal bone response, raising concerns about compliance with therapy as well as identifying patients for further evaluation and specific added treatment. How reliable, practical, and cost-effective this approach is for routine clinical use is a reasonable question. Up-regulation of bone resorption markers identifies a state of excessive bone loss, which if left unchecked will result in progressive decline in bone mass. Notably, fracture risk is higher in individuals with evidence of low bone density and up-regulated bone loss

compared to either alone. **Single, random measurements of bone markers are not useful in predicting future bone loss, and bone turnover markers are insensitive indicators of response to raloxifene and calcitonin. Measurement of bone turnover markers is best confined to clinical trials, except in special situations as noted in this chapter.**

# TREATMENT OPTIONS FOR FRACTURE RISK REDUCTION

---

# Menopausal Hormone Treatment

Hormone therapy is an effective bone-protecting strategy that improves BMD and offers fracture risk reduction. Antifracture efficacy of hormone therapy is now documented by randomized, placebo-controlled clinical trials.<sup>1818,1819,1820</sup> The WHI (discussed in detail earlier in this chapter) reported fracture outcomes based on an average of 5.6 years of follow-up, comparing placebo treatment with daily 0.625 mg conjugated estrogen and 2.5 mg medroxyprogesterone acetate (similar results were also reported in the estrogen-only arm of the clinical trial)<sup>1179,1820</sup> (Table 17.17).

## TABLE 17.17 WHI—Fracture Outcomes

	Estrogen-Progestin	Placebo	Hazard Ratio
Osteoporotic fractures	733 cases	896 cases	0.76 (0.69–0.83)
Spinal fractures	41	60	0.65 (0.46–0.92)
Hip fractures	52	73	0.67 (0.47–0.96)
Lower arm/wrist fractures	189	245	0.71 (0.59–0.85)

The Kaplan-Meier estimates of the impact of hormone therapy in WHI indicated that the reduction in fractures continued to increase over time, suggesting that a very powerful effect would be achieved with treatment of a long duration. In addition, spinal fractures included only clinically symptomatic fractures (known to represent about one-third of vertebral fractures); again, the overall effect was probably greater if all vertebral fractures had been included. The beneficial effect was achieved even though the use of a bisphosphonate increased from 1% at baseline to about 6% in the estrogen-progestin group and 10% in the placebo group. The effect would have been even greater if bisphosphonates had not been prescribed by the participants' clinicians. In the WHI, hormone therapy decreased the risk of hip fracture by 60% among women with adequate calcium intake at baseline, but not in those with a lower intake. This underscores the importance of emphasizing to patients the consequences of inadequate calcium and vitamin D intake. The impact of hormone therapy was greater in leaner women, as one would expect. **Thus, the results of the WHI provide us with clinical trial evidence for a therapy that protects against fractures in a population not selected for having osteoporosis.** Hormone therapy use in the United States declined by at least 50% following the initial publications from the WHI, and this decrease was paralleled by a significant increase in the incidence of fractures among postmenopausal women!<sup>1821</sup>

Estrogen therapy stabilizes the bone turnover in favor of net bone gain through suppression of bone resorption. Besides inhibiting osteoclastic resorption activity, estrogen increases intestinal calcium absorption, increases 1,25-dihydroxyvitamin D

(the active form of vitamin D), increases renal conservation of calcium, and supports the survival of osteoblasts. With estrogen therapy, one can expect a 50–60% decrease in fractures of the arm and hip,<sup>501, 1713, 1822, 1823</sup> and when estrogen is supplemented with calcium, an 80% reduction in vertebral compression fractures can be observed.<sup>525</sup> This reduction is seen primarily in patients who have taken estrogen for more than 5 years.<sup>1129, 1710</sup> **Protection against fractures wanes with advancing age, and long-term estrogen use is necessary to maximally reduce the risk of fracture after age 75.**

Because most osteoporotic fractures occur late in life, women and clinicians must understand that the short-term use of estrogen immediately after menopause cannot be expected to offer sustained protection against fractures in the seventh and eighth decades of life. Some long-term protection is achieved with 7–10 years of estrogen therapy after menopause, but the impact is minimal after age 75.<sup>1824</sup> In a prospective cohort study of women 65 years of age and older, in those who had stopped using estrogen, and in those who were over 75 and had stopped estrogen after more than 10 years use, there was no substantial effect on the risk for fractures.<sup>1711</sup> Any substantial fracture risk reduction effect from hormone therapy requires treatment initiation within 5 years of onset of menopause and for current use to extend into the elderly years. **The protective effect of estrogen rapidly dissipates after treatment is stopped because estrogen withdrawal is followed by rapid bone loss.** In the 3- to 5-year period following loss of estrogen, whether after menopause or after cessation of estrogen therapy, there is an accelerated loss of bone.<sup>1825, 1826, 1827, 1828, 1829</sup> The PEPI trial, however, found that this rate of bone loss was comparable to that in women not on hormone therapy,<sup>1830</sup> but in a Swedish case-control study, most of the beneficial effect of hormone therapy was lost 5 years after discontinuing treatment.<sup>501</sup> An American randomized trial concluded that elderly women who stopped taking hormones lost most of the bone density gained while on hormone therapy.<sup>1831</sup> Two reports documented that less than 4 years of exposure to estrogen is followed by a period of time, perhaps 10 years, when bone density is better and fractures are less prevalent than nonusers of hormone therapy.<sup>1832, 1833</sup> This protection is not as great as that obtained with long-term hormone use, and beneficial effects should not be expected after age 70, when fractures are most prevalent.

Maximal protection against osteoporotic fractures, therefore, requires lifelong therapy; even some long-term protection requires 10 or more years of treatment, and some protection against fractures is lost within 5 years of discontinuation.<sup>1712, 1834</sup> Standard doses of systemic estrogens that are commonly utilized for symptom control offer skeletal benefit, regardless of route of administration.<sup>501</sup> A study of women randomized to treatment either with continuous transdermal delivery of estradiol 50 mg daily or oral estrogen demonstrated that both equally prevented postmenopausal bone

loss.<sup>1835</sup>

In the PEPI trial, at the end of 3 years, the women receiving hormone treatment had experienced about a 5% gain in BMD in the spine and 2% in the hip compared with approximately a 2% loss in the placebo group.<sup>574</sup> How long does this gain in bone density continue in hormone-using women? In a 10-year follow-up study of women receiving estrogen-progestin therapy, the spinal bone density steadily increased, reaching a level 13% over baseline after 10 years of treatment.<sup>1836</sup> In another cohort study, hormone users did experience a loss of bone at the hip over a 10-year period of time; however, the incidence of hip, wrist, and vertebral fractures was significantly reduced in the hormone users.<sup>1837</sup>

The idea of postponing treatment to prevent osteoporosis until later in life has some merit. Changes in bone density in the early postmenopausal years have no major effect on fractures later in life, except in individuals who already have low bone density. This amounts to only 5% of women in their early postmenopausal years, and most of this 5% will have risk factors such as smoking, history of fracture at a younger age, lean body mass, or excessive alcohol consumption. The positive impact of hormone therapy on bone has been demonstrated in women over age 65 and even over age 75.<sup>1129, 1710, 1711, 1824, 1838, 1839, 1840</sup> This may be a strong argument in favor of treating very old women with estrogen for skeletal benefit, as estrogen use between the ages of 65 and 74 has been documented to protect against fractures.<sup>1713</sup> However, starting hormone treatment later in life and solely for the benefit of bones is a controversial issue. The WHI hormone trials should serve as a reminder that we must strive to balance purported benefits of hormone therapy against risks that are enhanced in aging populations, such as stroke. A large cohort study could detect no significant impact on nonspinal fractures.<sup>1711</sup> In a later analysis of this same cohort, some reduction in fracture risk was observed in women starting hormone therapy after age 60, but a statistically significant reduction was present only in those who started treatment before age 60 and remained on it.<sup>1841</sup>

Older studies suggested that a dose of 0.625 mg of conjugated estrogens is necessary to preserve bone density.<sup>1842</sup> The conventional wisdom has stated that an estradiol blood level of 40–60 pg/mL is required to protect against bone loss.<sup>1843, 1844</sup> We now know that any amount of estrogen can have an impact, although it is very likely that some degree of protection is lost when doses are less than the equivalent of 0.625 mg conjugated estrogens or 1.0 mg estradiol.

The rate of bone loss and the incidence of hip and vertebral fracture is inversely related to the circulating estrogen levels in older women.<sup>1845, 1846</sup> Estradiol levels as low as 10 pg/mL have a beneficial impact on bone density and fracture rates compared

with values below 5 pg/mL. **Thus, any increment in estrogen, even within the usual postmenopausal range, will exert protective effects.** This explains how a positive effect on bone was observed even with the utilization of the vaginal ring that delivers a very small amount of estradiol with minimal systemic absorption.<sup>558</sup>

A lower dose of 0.3 mg daily of conjugated estrogens or 0.5 mg estradiol prevented loss of vertebral trabecular bone when combined with calcium supplementation (to achieve a total intake of 1,500 mg daily).<sup>576, 1847, 1850</sup> In a small study without calcium supplementation, daily administration of 0.3 mg conjugated estrogens and 2.5 mg medroxyprogesterone acetate produced a slight increase in lumbar bone density with a lesser effect on the hip.<sup>1851</sup> Even a dose of estradiol as low as 0.25 mg/day produced an increase in bone density.<sup>579</sup>

The Women's Health, Osteoporosis, Progestin, Estrogen (HOPE) trial involved 800 postmenopausal women in a dose-response evaluation of conjugated estrogens and medroxyprogesterone acetate. The lowest dose, 0.3 mg conjugated estrogens, either unopposed or combined with 1.5 mg medroxyprogesterone acetate, produced a gain in bone density.<sup>577</sup> A major concern with lower doses is the possibility that there will be a significant percentage of nonresponders (discussed later). Nevertheless, a lower dose of estrogen may be more acceptable (fewer side effects) in elderly women.

Certain progestational agents have been reported to act independently, in a manner similar to estrogen, to reduce bone resorption.<sup>1852</sup> When added to estrogen, progestins can lead to an apparent synergistic increase in bone formation associated with a positive balance of calcium.<sup>1853, 1854, 1855, 1856</sup> On the other hand, other studies have failed to find a greater impact on bone, comparing estrogen alone to estrogen plus a progestin.<sup>1711</sup> These different results are explained by the fact that the synergistic result of combining estrogen with a progestin is determined by the type of progestin, being limited to members of the 19-nortestosterone (norethindrone) family.<sup>571</sup> This could reflect an increase in free estrogen levels because of a reduction in SHBG. Careful studies indicate that the addition of medroxyprogesterone provides an additional effect on bone density only in women with established, significant osteoporosis.<sup>1856, 1857, 1858</sup>

In the PEPI trial, at the end of 3 years, there was little difference comparing treatment with estrogen only to the groups receiving either sequential or continuous combinations of estrogen and medroxyprogesterone acetate or micronized progesterone.<sup>574</sup> Thus, the daily, continuous combination of estrogen-progestin is equally efficacious in maintaining bone density as the sequential regimens, although at least one study has indicated a slightly greater response in the lumbar spine with continuous treatment.<sup>571, 610, 1859, 1860</sup>

The addition of testosterone to an estrogen therapy program has been reported to



provide no additional beneficial impact on bone or on relief from hot flushes.<sup>613, 617</sup> Others have demonstrated a greater increase in bone density with an estrogen-androgen combination compared with estrogen alone, although the blood estrogen levels achieved were higher than those associated with standard postmenopausal hormone therapy.<sup>615</sup> In another study, only a very pharmacologic dose of methyltestosterone added to the bone density achieved with estrogen alone.<sup>618</sup>

**We support the consideration of early initiation of menopausal hormone therapy in early menopausal women with evidence of low bone mass as a fracture risk reduction strategy, but caution that consideration for prolonged use of hormone regimens in postmenopausal women must be individualized. If long-term use of menopausal hormone therapy is chosen as the preferred approach to fracture risk reduction, prescribers are cautioned on the importance of periodic reassessments and timely adoption of risk reduction strategies (such as switching from oral to transdermal route and reduction in dose of estrogen) to ensure that patients electing to be treated with hormones achieve protection against osteoporotic fractures while mitigating estrogen-related risks. Testosterone should not be prescribed with the expectation that androgen treatment will improve bone health.**

## **Follow-Up Assessment of Hormone-Treated Women**

Either a stable bone density or an increase indicates successful treatment; however, not all women will maintain or gain bone density on postmenopausal hormone therapy; in one study, 12% of treated women lost bone despite apparently good compliance.<sup>500</sup> In the PEPI 3-year clinical trial, where compliance rates were probably maximal, 4% of treated women lost bone in the spine and 6% in the hip.<sup>574</sup> **It is worthwhile to repeat bone density assessment following initiation of hormone therapy for skeletal benefit to assess response in treated women when they are in their late 60s.** This problem of poor response is discussed near the end of this section.

# Selective Estrogen Receptor Modulators

## Raloxifene

Raloxifene is the prototype SERM that is commonly utilized in the management of osteoporosis. SERMs act as agonists-antagonists at the level of estrogen receptors and can have selective actions on specific target tissues. Raloxifene produces favorable estrogen-like responses in bone and on lipids, but unlike estrogen, it is neutral at the level of the endometrium.<sup>649, 650</sup> In contrast to estrogen, raloxifene also has proven efficacy in reducing risk for breast cancer. The changes in bone remodeling produced by raloxifene are consistent with an estrogen agonist effect.<sup>1861</sup> As with estrogen therapy, discontinuation of raloxifene treatment is followed by a resumption of bone loss.<sup>1862</sup>

The increase in bone density associated with raloxifene, 60 mg daily, is less than that seen with bisphosphonate, alendronate.<sup>1863, 1864, 1865</sup> The MORE study of raloxifene administration to osteoporotic women reported results from 8 years of follow-up.<sup>653, 654</sup> Women with low bone density T-scores had approximately a 50% reduction in vertebral fractures with raloxifene treatment; those with previous vertebral fractures had approximately a 35% reduction. However, **there has been no evidence of a reduction in hip or wrist fractures with raloxifene use.** Although the reduction in vertebral fractures is similar to that seen with alendronate and estrogen, why is there no decrease in hip fractures, despite a bone density response that is only slightly less than that associated with alendronate? There are at least two possible explanations. The study was of insufficient duration to demonstrate an impact in a population that was relatively young for hip fractures. Or a weaker impact on bone density produces a lesser effect in the hip, which has a combination of cortical and trabecular bone that is less responsive compared with the spine with its large content of trabecular bone.

A reduction in vertebral fractures with raloxifene that is equivalent to that with estrogen or bisphosphonates despite a lesser increase in bone density is strong evidence that fracture risk and reduction are not simply reflections just of bone density. Thus, a few percentage point differences comparing bone densities between two therapies do not translate into a difference in fracture protection. For this reason, fracture data are important, and we cannot conclude that small differences predict lesser or better performances in fracture protection. Another example is the greater gain in bone density associated with combination treatment with alendronate and estrogen; a greater gain in bone density does not necessarily mean a greater protection against fractures. Similar to estrogen, use of raloxifene has been associated with a small but real risk for thrombotic events. **In our view, raloxifene is an option for prevention of osteoporosis-related spinal fractures, especially for those who are deemed at an enhanced risk for both**

**breast cancer and spine fracture risk. We recommend, however, periodic evaluation of bone density in the hip, as if ongoing site-specific bone loss continues despite compliance with raloxifene, patient and clinician should consider another treatment option that offers broader skeletal benefits at the level of the hip as well as the spine.**

## **Bazedoxifene**

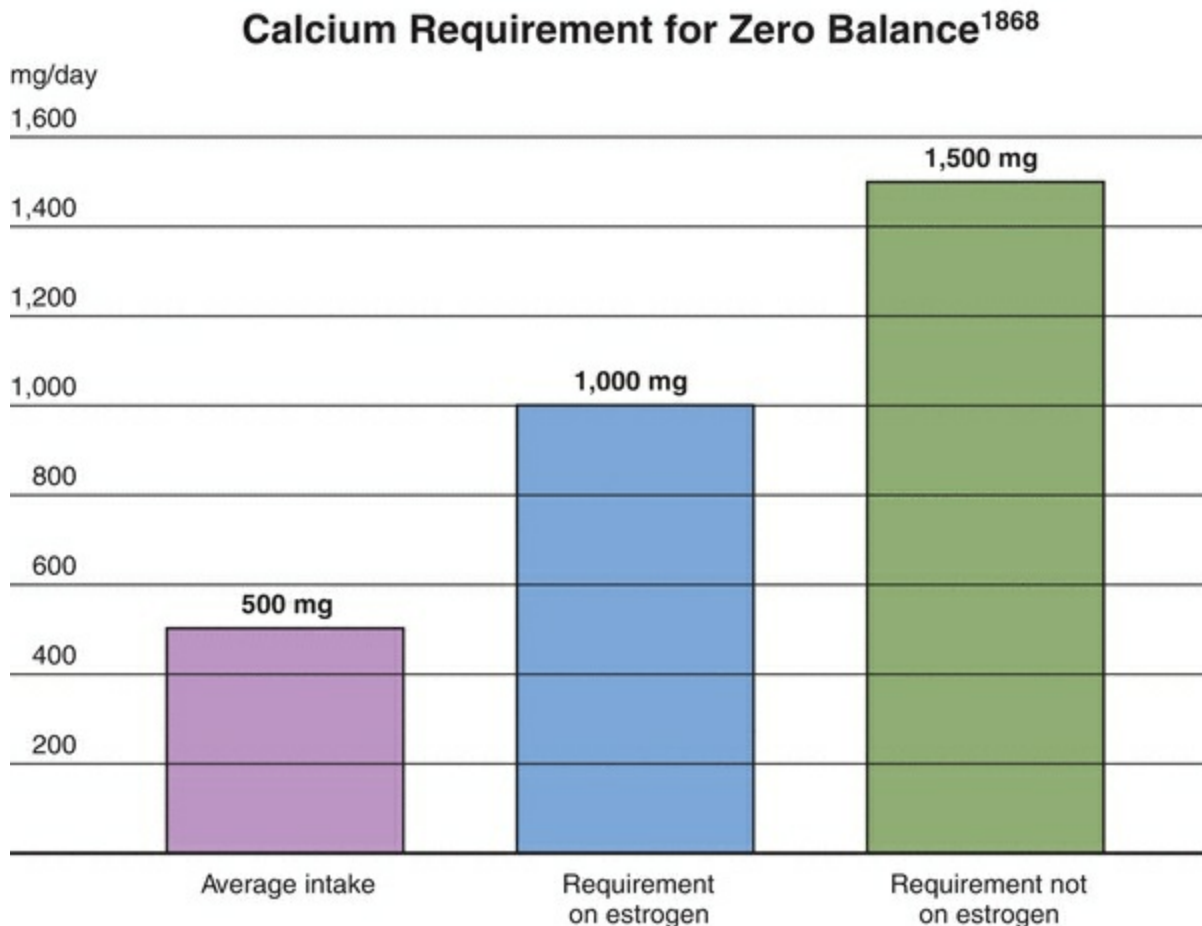
BZA is a third-generation SERM, with tissue-specific estrogen agonist-antagonist effects. It has favorable effects on bone and lipids, but does not affect the endometrium or the breast. BZA in a dose of 20 mg daily decreased the risk of all clinical fractures in a randomized clinical trial, with a potency comparable to other antiresorptive agents in postmenopausal women at high risk for fractures.<sup>670, 671</sup> In a subgroup of women at higher risk for fractures, BZA had a reduced risk of nonvertebral fractures (50% reduction with 20 mg), compared with both raloxifene and placebo. The only adverse event that differed with treatment was an increase in venous thrombosis with treatment compared with placebo. The results of this trial indicate that the effect of BZA on bone should be comparable to that of estrogen and bisphosphonates.

The reduction of nonvertebral fractures with BZA compared with raloxifene should not be ignored. We have known for some time that even with 8 years of follow-up, raloxifene has no impact on the risk of hip fractures. This is likely because raloxifene is less potent, and thus the hip with a mixture of cortical and trabecular bone is more resistant to raloxifene's effects, compared with the spinal column that is composed of sensitive, trabecular bone. As discussed earlier in this chapter, BZA partnered with conjugated estrogen is the first TSEC to be made available in the United States for menopause management. The idea is to gain the benefits of estrogen (BZA has little impact on hot flashes), protect the endometrium and possibly the breast, and enhance some actions of estrogen, such as a reduction in fractures. This approach to postmenopausal hormone therapy has eliminated a concomitant need for progestational agents in hormone-using postmenopausal women with an intact uterus. **In our opinion, the combination of BZA and estrogen is a promising option for reducing risk of osteoporosis; its efficacy in reducing fracture risk however remains unclear, and future studies are awaited to determine how risk reduction benefit of TSEC against fractures, if any, compares to that of traditional hormone therapy.**

# Calcium Supplementation

There has been considerable confusion over whether calcium supplementation by itself can offer protection against postmenopausal osteoporosis. This is partly due to the fact that calcium studies were performed in women who were in the very early postmenopausal years, in the midst of the rapid loss of calcium associated with estrogen deficiency, and this estrogen effect overwhelmed any responses to calcium. Studies that involved women beyond this early stage of the postmenopausal period indicated a positive impact of calcium supplementation.<sup>1866, 1867, 1868, 1869</sup>

Calcium absorption decreases with age because of a decrease in biologically active vitamin D and becomes significantly impaired after menopause. A positive calcium balance is mandatory to achieve adequate prevention against osteoporosis. Calcium supplementation (1,000 mg/day) reduces bone loss and decreases fractures, especially in individuals with low daily intakes.<sup>1870, 1871</sup> Estrogen acts to improve calcium absorption by increasing the levels of 1,25-dihydroxyvitamin D and makes it possible to utilize effective supplemental calcium in lower doses (**Figure 17.23**).



**FIGURE 17.23**

## Key Points: Calcium Supplementation

- In order to remain in zero calcium balance, postmenopausal women require a total of 1,200 mg elemental calcium (through diet and supplements) per day.<sup>1870, 1872, 1873</sup>
- Because the average woman without any dietary restrictions receives about 500–700 mg of calcium in her diet, the minimal daily supplement for women on estrogen equals an additional 500 mg.

High-dose calcium supplementation can unmask asymptomatic hyperparathyroidism, causing abnormally high calcium blood levels and an increased risk for renal stones.<sup>1874, 1875</sup> Assessment of dietary intake and restrictions should be undertaken at routine clinical visits, and recommendations on dose of supplementation should be individualized based on dietary intake. Women receiving calcium supplementation in excess of 500 mg daily should have their blood levels of calcium and phosphorus measured yearly for the first 2 years. If normal, no further surveillance is necessary.

Even with the commonly used therapeutic doses of calcium, nearly 40% of postmenopausal women have inefficient absorption.<sup>1876</sup> Estrogen improves calcium absorption and allows the utilization of supplemental calcium in effective doses without the side effects associated with higher doses (constipation and flatulence) that diminish compliance. **We must emphasize that although calcium supplementation is important, it cannot provide the same degree of protection against osteoporosis as that achieved by hormonal therapy or raloxifene or agents discussed later in this section.**<sup>1877, 1878</sup> Nevertheless, the beneficial impact of estrogen on bone is reduced in the absence of calcium supplementation.<sup>1848</sup> Skeletal harm from low calcium intake in the aging population gets compounded if there is coexisting insufficient dietary intake of proteins.<sup>1879</sup>

Improved calcium intake in adolescents results in significant increases in bone density and skeletal mass, providing protection against osteoporosis later in life.<sup>1880, 1881</sup> Calcium supplementation is far more important during adolescence than in the reproductive years when bone formation is minimal. Under age 25, during the years of bone accumulation, the recommended daily calcium intake is 1,300 mg.<sup>1882</sup> This amount, 1,300 mg/day, is also recommended during pregnancy and lactation. Most calcium comes from dairy products; relying on other foods is not easy because it requires a high intake volume of other foods to provide the same amount of calcium in normal daily servings of dairy products (Table 17.18). Foods with high amounts of oxalate and

phytate, such as spinach, rhubarb, beans, peas, wheat bran, and beet greens, reduce calcium absorption.

## **TABLE 17.18 Calcium Content of Foods**

## Calcium Content of Foods

Yogurt (1 cup)	415 mg
Yogurt with fruit (1 cup)	345 mg
Juice fortified with calcium (1 cup)	300 mg
Milk (1 cup)	300 mg plus 100 IU vitamin D
Ice cream (1 cup)	175 mg
Cottage cheese (1 cup)	140 mg
Romano cheese (1 oz)	300 mg
Parmesan cheese (1 oz)	335 mg
Cheddar cheese (1 oz)	205 mg
Swiss cheese (1 oz)	270 mg
Mozzarella cheese (1 oz)	207 mg
Tofu (1 cup)	150 mg
Broccoli, cooked (1 cup)	140 mg
Beans, cooked (1 cup)	80 mg

There are dozens of calcium supplements on the market, containing calcium carbonate,

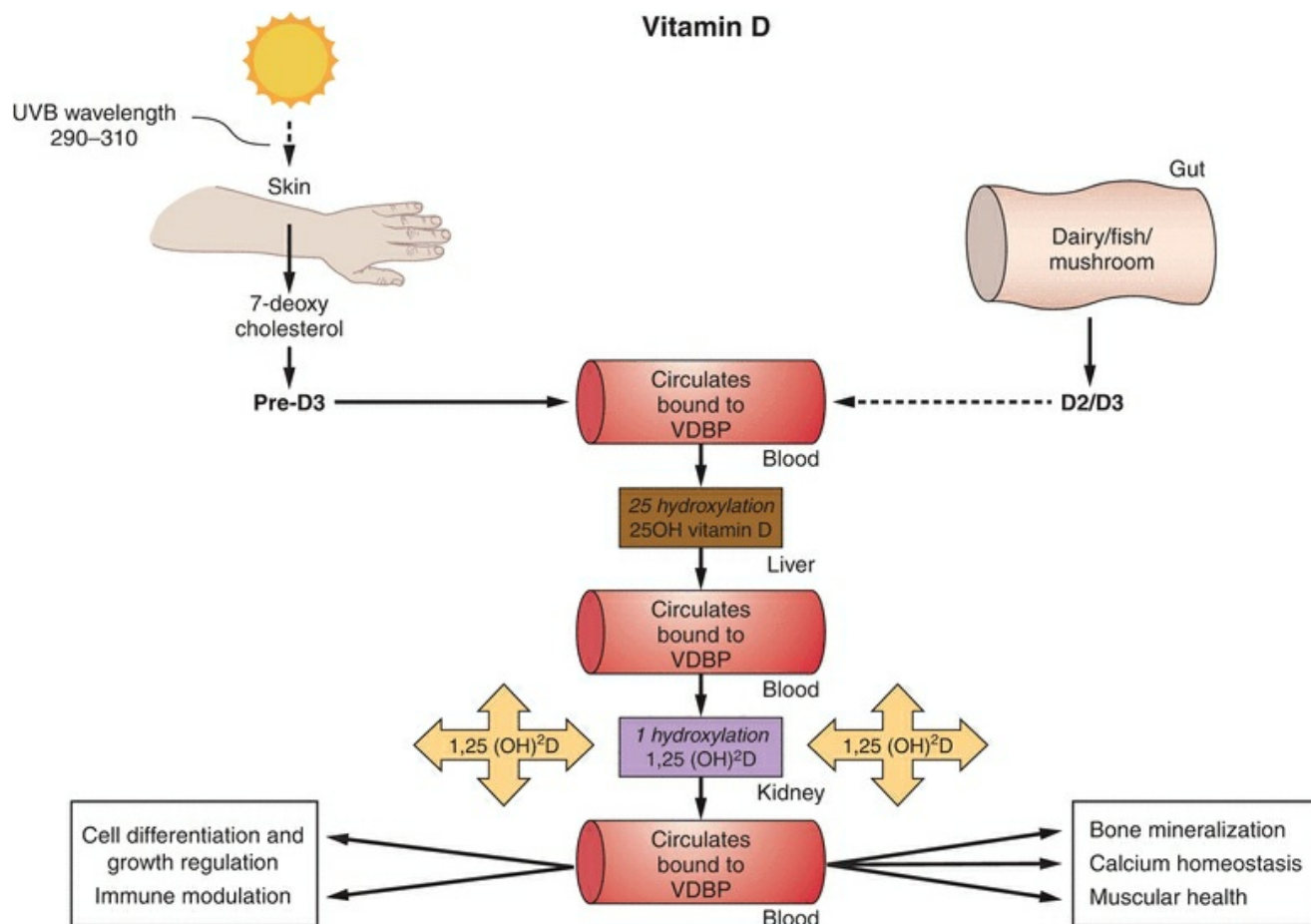
calcium lactate, calcium phosphate, or calcium gluconate. Calcium carbonate tablets are the cheapest and contain the most elemental calcium (40%). Calcium lactate tablets contain 13% calcium, calcium citrate 23%, and calcium gluconate only 9%. The calcium carbonate antacids are excellent, inexpensive sources. Be aware that aluminum-containing antacids such as Maalox, Mylanta, Gelusil, and Riopan can inhibit gastrointestinal absorption of calcium. Bone meal and dolomite as sources of calcium should be avoided because they are contaminated with lead. Calcium carbonate derived from “natural” sources (such as oyster shell), brand-name formulations, and even “refined” products can also contain lead.<sup>1883</sup> It is worth looking for specific products labeled as tested and containing no lead, having “purified” or “USP Verified Mark” on the label. Calcium citrate does not require gastric acid for absorption and is the best choice for older patients with reduced gastric acid production. Calcium supplementation is most efficient when single doses do not exceed 500 mg and when taken with a meal. **Excess calcium supplementation (especially not with meals) is associated with a slight increase in risk for kidney stones.**<sup>1874,1884</sup>



# Vitamin D

Changes in vitamin D and calcium metabolism accompany aging and contribute to the aging-related increase in skeletal fragility.<sup>1885,1886</sup> There is an age-related decrease in the ability of tissues to convert the major circulating form of vitamin D, 25-hydroxyvitamin D to the active form of vitamin D (1,25-dihydroxycholecalciferol, better known as 1,25-dihydroxyvitamin D), and there is a decrease in the ability of the intestine to absorb dietary vitamin D. Exposure of the skin to ultraviolet rays in sunlight stimulates the formation of cholecalciferol (vitamin D<sub>3</sub>). One dose of sunlight that produces erythema is equivalent to 10,000–25,000 IU of vitamin D. Excessive exposure to sunlight cannot cause toxic levels of vitamin D because any excess in vitamin D<sub>3</sub> is inactivated by ultraviolet radiation.

Vitamin D<sub>2</sub> (ergocalciferol) in commercial supplements has been replaced with the more effective vitamin D<sub>3</sub> (cholecalciferol), which is more than 3 times the potency of vitamin D<sub>2</sub>.<sup>1887</sup> Cholecalciferol and ergocalciferol are converted in the liver to calcitriol (25-hydroxyvitamin D), the major circulating metabolite that is active in stimulating the absorption of calcium and phosphate from the gastrointestinal tract. The circulating level of 25-hydroxyvitamin D and renal conversion to its active form, 1,25-dihydroxyvitamin D, are regulated by calcium, phosphorous, and parathyroid hormone (**Figure 17.24**).



**FIGURE 17.24**

The importance of optimization of vitamin D status through lifestyle modifications and judicious use of supplementation in aging populations cannot be minimized. For postmenopausal women, the recommended daily allowance for vitamin D is 600 IU.<sup>1882</sup> However, it is important to appreciate that RDA doses are inadequate to achieve correction of underlying vitamin D deficiency, and there is sufficient evidence to support safety of daily intake of 1,000–2,000 units of vitamin D in addition to calcium supplementation. Older studies that failed to document a beneficial impact of vitamin D supplementation were handicapped by doses that were too low and in the setting of inadequate calcium intake.<sup>1888</sup> A pooled analysis of 68,500 patients in seven major vitamin D fracture trials concluded that vitamin D in appropriate doses coupled with calcium supplementation reduced fractures at all sites in men and women.<sup>1889</sup>

Because adequate and active vitamin D depends on cutaneous generation mediated by sun exposure, women in the winter months can easily be relatively vitamin D deficient and lose bone.<sup>1890</sup> In far northern and southern areas, the winter sunlight is

inadequate to stimulate dermal activation. But even in areas of the world where there is adequate sun exposure, inadequate dietary intake and an indoor lifestyle yield a significant number of women with abnormally low levels of circulating 25-hydroxyvitamin D.<sup>1891</sup> In addition, clothing and sunscreens prevent the cutaneous production of vitamin D<sub>3</sub>. The NHANES documented a rising prevalence of vitamin D insufficiency in the United States over the last two decades.<sup>1892</sup> **If uncertain regarding vitamin D supplementation, the serum level of 25-hydroxyvitamin D can be measured; although the Institute of Medicine (IOM) in the United States has lowered the threshold to define vitamin D deficiency to less than 20 ng/mL, the U.S. Endocrine Society maintains that a level below 30 ng/mL is abnormal.**<sup>1822,1893</sup>

The benefit of vitamin D supplementation is clear in older postmenopausal women, and the lack of side effects encourages us to recommend vitamin D supplementation as part of the overall program for osteoporosis prevention in younger postmenopausal women. But keep in mind that effective bone response to vitamin D requires adequate calcium intake.

One caution regarding vitamins: excessive intake of vitamin A, specifically retinol, was reported to be associated with an increased rate of hip fractures in the women not using hormone therapy in the Nurses' Health Study; it would be better to avoid obtaining vitamin D by taking more than one multivitamin tablet daily.<sup>1894</sup> It has been argued that excess retinol intake may explain the higher rate of fractures in Scandinavia.<sup>1895</sup>

The WHI conducted a randomized trial of calcium and vitamin D supplementation.<sup>1896</sup> The 36,282 postmenopausal women were part of the WHI clinical trials involving postmenopausal hormone therapy or dietary modification. The average follow-up was 7 years. Thirty-seven percent of the women were age 50–59, 45.5% were 60–59, and 17.5% were 70–79. The treated group was supplemented with 1,000 mg calcium and 400 IU vitamin D daily. Overall analysis indicated no significant reduction in fractures with calcium/vitamin D treatment. The women treated with calcium/vitamin D had a 17% greater risk of kidney stones. However, a closer look reveals some good news:

- Correcting for compliance by analyzing just those women who continued their medication revealed a statistically significant 29% reduction in risk for hip fractures. Only 59% of the treated women at the end of the trial were taking the intended dose.
- Women who were 60 years and older had a 21% significant reduction in hip fractures.
- The reduction in hip fractures was greatest (42%) in those women who combined calcium/vitamin D supplementation with postmenopausal hormone therapy.

The population at greatest risk for fractures (the oldest women in the WHI study) actually benefited, and the study confirmed something already known that hormone therapy combined with calcium/vitamin D supplementation achieves the best results. Keep in mind that the women in this study were not at high risk for fractures. Indeed, whole-body and spinal bone density increased in the placebo group. This is hard to explain; the average postmenopausal untreated woman loses spinal bone density. In this study, only hip bone density demonstrated a loss, and thus, it is not surprising that significant benefits were demonstrated only with hip fractures. The fact that most of these women were overweight probably contributed to the protection against bone loss in the spine. In a population of women losing bone density in both the hip and spine, and in women with other risk factors for fractures, calcium/vitamin D supplementation should yield even better results than those reported by the WHI, including a reduction in spinal and arm fractures. Degenerative joint disease and resulting osteophytes can convey false reassurance of improved bone density on radiologic imaging including DEXA, and this may have contributed to the improved spine bone density observed in the WHI placebo group.

What about the kidney stones? The women in the WHI trial were allowed to continue their own programs of supplementation. Thus, many took calcium and multivitamins (which contain 400 IU vitamin D). The average daily calcium intake of the study population was 1,100–1,200 mg, twofold higher than the average American woman. The WHI does not provide data to answer this most important question: was the small increase in kidney stones observed in women who were taking excessive amounts of calcium and vitamin D?

The WHI has published multiple findings from the calcium/vitamin D randomized trial. The conclusions are uniformly negative, summarized as follows:

- The incidence of invasive breast cancer was similar in the treated and placebo groups. The risk of breast cancer was not associated with baseline 25-hydroxyvitamin D levels.<sup>1897</sup>
- Calcium and vitamin D supplementation did not protect against a decline in physical functioning or performance.<sup>1898</sup>
- The incidence of newly diagnosed diabetes was the same in the treated and placebo groups.<sup>1899</sup>
- Myocardial infarction and stroke events were similar in the treated and placebo groups.<sup>1900</sup>
- Calcium and vitamin D supplementation had no effect on blood pressure or the risk of developing hypertension.<sup>1901</sup>

The WHI also reported the effects on overall mortality in their randomized trial of

calcium and vitamin D supplementation.<sup>1902</sup> After an average follow-up of 7 years, there was no impact on total mortality (744 deaths in treated women and 807 deaths in the placebo group). There was a nonsignificant reduction (about 10%) in risks for stroke and cancer mortality. Comparing the women older than 70 to those younger than age 70, there was a lower risk for mortality in the younger group, but this did not achieve statistical significance. When analysis was restricted to those participants who were adherent to therapy, the results for overall mortality and for the younger women were essentially unchanged. However, a nested case-control study assessed the results according to serum 25-hydroxyvitamin D levels at baseline; the results indicated that women with the lowest levels had a higher risk for death. The WHI investigators concluded that their results weakly support the hypothesis that calcium and vitamin D supplementation modestly reduces cancer and cardiovascular mortality. Overall, the results indicated no major benefit of calcium and vitamin D supplementation on the risk of death due to cancer or cardiovascular disease.

Smaller trials and observational studies of vitamin D supplementation have demonstrated reductions in total mortality, reductions in blood pressure and cholesterol levels, and reduced risks of stroke and CHD. Vitamin D insufficiency has been linked to a wide spectrum of problems, including an increase in autoimmune diseases such as rheumatoid arthritis, upper respiratory tract infections, diabetes mellitus, multiple sclerosis, cancer, and cardiovascular disease. Low levels of serum 25-hydroxyvitamin D have been reported to be associated with higher all-cause mortality, greater prevalence of breast cancer, peripheral arterial disease, and higher cardiovascular mortality.<sup>1903,1904,1905,1906,1907</sup> It is proposed that many tissues produce locally the active 1,25-dihydroxyvitamin D that exerts beneficial effects on cell regulation and differentiation before being inactivated within cells without reaching the circulation and interfering with calcium metabolism.<sup>1886</sup>

What could explain the lack of strong agreement between the WHI results and the rest of the literature? The answer can be found in the characteristics of the women in the WHI and the doses of calcium and vitamin D used for supplementation. The women in the WHI were not at high risk for fractures, and most of the women were overweight. Only one-third of the participants had a low calcium intake at entry to the study, and 29% were already taking calcium supplementation. As previously noted, the average daily calcium intake of the study population was 1,100–1,200 mg, twofold higher than the average American woman.<sup>1896</sup> Low serum levels of 25-hydroxyvitamin D were found in only 25% of the women in whom it was measured.

The negative publicity associated with the WHI publications has obscured the importance of fracture risk in women. In the observational arm of the WHI, the risk of fracture was compared to the risks of cardiovascular events and breast cancer in a

prospective cohort of 83,724 women, aged 70–79.<sup>1908</sup> **The recorded events indicated that the number of women who experienced a fracture in 1 year's time exceeded the combined number of women experiencing invasive breast cancer or cardiovascular disease (except in blacks in whom cardiovascular events dominated).** And don't forget that in the WHI, the women adherent to their calcium/vitamin D supplementation had a 29% reduction in risk for hip fractures, and the reduction in hip fractures (42%) was greatest in those women who combined calcium/vitamin D supplementation with hormone therapy.<sup>1896</sup>

Because 60% of individuals who live in northern latitudes have low serum levels of 25-hydroxyvitamin D, the WHI results do not rule out the possibility of beneficial effects of adequate supplementation in a large segment of our population.<sup>1909</sup> The WHI nested case-control study documented that the risk of hip fracture steadily increases in women as their serum levels of 25-hydroxyvitamin D decrease.<sup>1910</sup>

**Vitamin D is essential for adequate calcium absorption and maximal bone protection, but remember that supplemental vitamin D requires adequate calcium intake.**<sup>1888,1889</sup> Calcium absorption decreases and parathyroid hormone increases as the levels of 25-hydroxyvitamin D fall below 30 ng/mL. Multiple studies have demonstrated that vitamin D together with calcium supplementation in older men and women reduces the rate of fractures.<sup>1877,1911,1912</sup> Normal vitamin D levels are important for muscle functioning; vitamin D supplementation alone and in combination with calcium lowers the risk of falling and improves lower extremity function in older men and women.<sup>1913,1914</sup> **We believe that vitamin D and calcium supplementation are simple yet critical strategies that offer risk reduction against fragility fractures through mechanisms that include positive effects on BMD, on bone quality, and possibly on muscular function. Supplementation strategies must utilize dietary sources as well as supplements, and dosing regimens should be individualized to the needs of the population at risk.**

## Key Points: Vitamin D

- Clinicians should be vigilant toward identifying populations at risk for vitamin D deficiency and be more aggressive in confirming their impression through monitoring serum levels of 25-hydroxyvitamin D. While a level less than 20 ng/mL is a definitive indication of vitamin D deficiency, any value less than 30 ng/mL is below normal and must be interpreted in the context of the overall picture. We believe that this measurement should be part of every older individual's annual medical assessment.

- The choice of vitamin D supplementation dose and regimen should be dictated by the severity of deficiency, and periodic surveillance is advised to ensure effectiveness of chosen regimen and to safeguard against a small but real risk of overdosing. It takes about 3 months after initiation of supplementation for serum levels of 25-hydroxyvitamin D to reach a new steady state after a change in dose.
- Patients who lose bone despite adequate treatment for bone loss must have serum 25-hydroxyvitamin D and calcium measurements because inadequate calcium and vitamin D can be an easily correctable reason for suboptimal response to effective regimens.

Given these facts, how can we determine how much vitamin D to give to an individual patient? A collection of bone experts reached a consensus by considering the amount of vitamin D supplementation required to change blood levels of 25-hydroxyvitamin D and parathyroid hormone, correlating this information with the levels of vitamin D required to prevent bone loss.<sup>1915</sup> The U.S. IOM recommends intake of 600 IU as the daily allowance of vitamin D for postmenopausal women until age 70, with an increase in recommended allowance to 800 IU daily for women 71 and older. However, in women with documented evidence of vitamin D deficiency (serum 25-hydroxyvitamin D < 30 ng/mL), doses as high as 1,500–2,000 IU/day can be safely utilized to achieve levels required to maintain the optimal serum level of 25-hydroxyvitamin D, greater than 30 ng/mL. Short durations (3 months) of higher-dose regimens are often utilized to achieve restoration of low level of 25-hydroxyvitamin D to normal, such as 50,000 IU vitamin D<sub>2</sub> (available as prescribed formulation in the United States) administered once or twice weekly for 3–6 months followed by switch to lower-dose daily regimens of 600–2,000 IUs. Toxic doses of vitamin D (enough to produce hypercalcemia) are far beyond these recommendations.

# Bisphosphonates

Bisphosphonates are effective in preventing bone loss by enhancing osteoclast apoptosis and inhibiting bone resorption. The bisphosphonates share a basic phosphate-carbon-phosphate core and bind avidly to the bone mineral calcium where they remain for many years, making bone less susceptible to osteoclastic action. The first generation of bisphosphonates (etidronate) also inhibited bone mineralization, and therefore intermittent therapy was necessary. The newer generations of bisphosphonates allow bone formation to occur while inhibiting bone resorption and make it possible to use continuous therapy rather than intermittent therapy.

**Diagnostic screening with the laboratory tests previously noted is important before the administration of bone-specific drugs in order to avoid inappropriate treatment in the presence of a secondary cause for osteoporosis, especially renal disease.**

Oral bisphosphonates must be taken on an empty stomach with a full glass only of water, no other liquid, at least 30 minutes before any other food or liquid intake in order to achieve adequate absorption. A failure to remain upright for at least 30–60 minutes and until after the first food intake of the day after ingesting bisphosphonates can result in esophageal injuries, such as esophagitis, esophageal ulcers, and esophageal erosions with bleeding.<sup>1916</sup> Upper gastrointestinal problems in clinical trials (with carefully instructed and monitored subjects) are similar comparing alendronate treatment with placebo, indicating that improper usage is the culprit.<sup>1917,1918</sup> Risedronate (Actonel), 5 mg daily, is as effective as alendronate (Fosamax) for the prevention of bone loss, provides similar protection against fractures, and may be better tolerated.<sup>1919,1920,1921,1922,1923</sup> Other equally effective bisphosphonates include ibandronate (Boniva) and zoledronic acid (Reclast, Aclasta). Notably, zoledronic acid administered as a single 5-mg dose intravenously protects against bone loss for at least 2 years.<sup>1924,1925</sup>

The mechanism for the gastrointestinal reactions is an interference with the normal healing process that repairs trauma associated with eating. With less frequent exposure, this healing is allowed to proceed unimpeded. Periodic administration with equivalent bone efficacy is possible because of the high affinity of bisphosphonates for bone. Thus, weekly administration of alendronate and risedronate, each in a dose of 35 mg for prevention and 70 mg for treatment, reduces side effects and produces similar increases in bone density compared with a daily regimen.<sup>1926,1927,1928,1929,1930</sup>

In women with osteoporosis, alendronate (10 mg daily) administration reduced the risk of all subsequent fractures by 30% and vertebral fractures by 50% in 3–4 years of treatment.<sup>1931,1932,1933</sup> In normal postmenopausal women, alendronate increased bone



density in both the spine and the hip, and the 5-mg dose (the preferred dose for preventive treatment) was more effective than 2.5 mg.<sup>1934,1935</sup> In the data derived from follow-up of 4,432 women for an average of 4.2 years, a statistically significant reduced risk of fracture was demonstrated only in women with initial T-scores of  $-2.5$  or less, a 36% reduction in all fractures and a 50% reduction in vertebral fractures.<sup>1936</sup>

Bisphosphonate treatment obviously benefits women who already have a low bone density or previous vertebral fractures. Risedronate reduces vertebral and hip fractures in women with osteoporosis with an impact similar to that of alendronate.<sup>1921,1937</sup> After 5 years of treatment with risedronate, the risk of new vertebral fracture decreased by 59%, an improvement from the 49% reduction reported after 3 years.<sup>1938</sup> Ibandronate reduced vertebral fractures by about 60% over 3 years; zoledronic acid reduced vertebral fractures by 70% and hip fractures by 41% over 3 years.<sup>1939,1940</sup>

The EPIC (Early Postmenopausal Interventional Cohort) study concluded that over a 4-year period of time, alendronate and hormone therapy in the United States produce similar bone density results. The greater increase noted in Europe with hormone therapy probably reflects the use of 19-nortestosterone progestins, which are known to have an additive effect on bone density when combined with estrogen. Combining bisphosphonate and hormone therapy produces an added gain in bone density. When women who were already taking hormone therapy also received alendronate (10 mg) for 1 year, the gain in bone density ranged from 0.9% in the femoral neck to 2.6% in the spine.<sup>1941</sup> In women with osteopenia, combined therapy with alendronate 10 mg and 0.625 mg conjugated estrogens produced a 1–2% greater gain in bone density over a 2-year period of treatment; similar results were reported in a 1-year trial with risedronate.<sup>1942,1943</sup> **There are no data available on whether addition of a bisphosphonate to estrogen regimen improves antifracture efficacy of either agent alone. Furthermore, there is a theoretical concern that oversuppression of resorption can ultimately yield more brittle bones.**

Compliance with alendronate has been overestimated by the clinical trials. It is well-recognized that participants in clinical trials are better motivated, are better supported, and perform better. In the Kaiser Permanente Medical Care Program in California, about one-third of patients had acid-related complaints, and one in eight required treatment.<sup>1944</sup> About 50% of the Kaiser patients did not comply with instructions, and about 50% discontinued therapy by 1 year.<sup>1944,1945</sup> Analysis of general pharmaceutical claims databases in the United States revealed that only 43% refilled their first prescription, and after 2 years, only 20% were adherent to treatment.<sup>1946</sup> Bone density measurements are recommended to assess compliance and to provide motivation for continuation; compliance can also be assessed by measuring bone markers prior to

initiation of therapy and then repeating assessment 1–3 months later; a 30% decrease in bone markers is anticipated if patients are compliant with prescribed strategy and there are no major issues of malabsorption. Programs with good patient support have reported long-term compliance with hormone therapy: 65% at 7.5 years in an Australian population and 61% at 7 years in the United Kingdom.<sup>1947,1948</sup>

Because of the apparent benefits associated with alendronate therapy, the clinical trials were halted after 4 years, although follow-up has indicated persistent gains in BMD through 10 years of use.<sup>1949</sup> There is evidence that a bisphosphonate already in the bone can recirculate when bone containing the bisphosphonate is remodeled.<sup>1950</sup> Thus, perhaps long-term treatment with this class of agents is unnecessary. Comparing bone loss after discontinuation of treatment, accelerated bone loss occurs after estrogen and raloxifene, but a residual effect on bone density is maintained for up to 7 years after alendronate is discontinued<sup>1862,1951,1952,1953</sup> (Table 17.19).

## **TABLE 17.19 Bisphosphonates—Recommended Dosages**

	For Prevention	For Treatment
Alendronate	5 mg daily; 35 mg weekly	10 mg daily, 70 mg weekly
Risedronate	5 mg daily	5 mg daily
	35 mg weekly	35 mg weekly
	75 mg daily for 2 d each month	75 mg daily for 2 d each month
Ibandronate	150 mg monthly	150 mg monthly
	2.5 mg daily	2.5 mg daily
		150 mg monthly
Zoledronic acid	5 mg IV every 2 y	3 mg IV every 3 mo
		5 mg IV annually

## How Long Should Bisphosphonate Treatment Be Continued?

In an extension of the alendronate Fracture Intervention Trial (FIT), the participants were randomized after 5 years of treatment either to another 5 years of treatment or placebo.<sup>1954</sup> The group that discontinued alendronate treatment (5 or 10 mg/day) experienced small losses of BMD over 5 years. The levels, however, remained above the pretreatment levels 10 years previously. There were no differences in nonvertebral fractures between the treatment and placebo groups, but there was a twofold higher rate of clinically recognizable vertebral fractures in the placebo group (5.3% vs. 2.4%). It was concluded that for most women, a period of drug holiday may be safely considered

after 5-year treatment with alendronate and that long-term treatment beyond 5 years should be limited to high-risk women (women with existing vertebral fractures or very low bone densities).

The rate of hip fracture among women who discontinued bisphosphonate therapy was compared with women who remained on treatment.<sup>1955</sup> The study group consisted of 9,063 users who had been compliant for at least 2 years. The hip fracture rate about doubled in the women who discontinued treatment compared with those who did not. After discontinuation for a year or longer, the risk of hip fracture increased by 9 months in women with low compliance rates. In women with high compliance rates for 2 or 3 years, there were no significant differences in fracture risk after discontinuation for up to 1 year later. Why is there this lingering effect?

The unique tight binding of bisphosphonates to bone matrix causes this class of drugs to remain in the body for decades. This is believed to be the explanation for why there is no rapid bone loss after discontinuing bisphosphonate treatment in contrast to the rapid loss that follows the termination of treatments such as estrogen or raloxifene or denosumab (discussed later). This is also the reason why concerns have been raised regarding long-term treatment because when bone remodeling releases bound bisphosphonate, it is free to be active again, and as a result, the endogenous bisphosphonate is added to the administered bisphosphonate, raising dosage exposure. The potential risk that has been long recognized is that prolonged exposure to bisphosphonates or excessive dosage would oversuppress bone resorption, thus oversuppressing bone turnover, a phenomenon referred to as adynamic bone that ultimately affects the biomechanical strength of bone and allows microcracks to accumulate. A unique type of fracture of the femur, commonly referred to as “atypical fracture,” is characterized by a transverse fracture in an area marked by hypertrophy of the cortex and has been associated with long-term use of bisphosphonates.<sup>1956</sup>

## **Bisphosphonates and Osteonecrosis of the Jaw**

Osteonecrosis of the jaw (ONJ) is a rare complication that has been described with long-term use of potent antiresorptive agents, including bisphosphonates and denosumab.<sup>1957</sup> In an analysis of information from the Surveillance, Epidemiology, and End Results (SEER) databank linked to Medicare claims, 16,703 cancer patients were identified who were treated with IV bisphosphonates (pamidronate and zoledronic acid) from 1995 to 2003.<sup>1958</sup> When 14,349 treated patients were matched with 28,698 controls, the treated group had a threefold increased risk of jaw or facial bone surgery and a very large increased risk of osteomyelitis of the jaw. The estimated absolute risk equaled 5.48 events per 100 patients over 6 years. In addition, the risk increased with increasing cumulative dose. The absolute risk is much less in noncancer patients being

treated with bisphosphonates for the management of osteoporosis, in whom the incidence of ONJ is estimated at 0.001–0.01%, minimally higher than in the general population.<sup>1957</sup>

The mechanism underlying ONJ in bisphosphonate users is uncertain beyond the recognition that infection and blood flow changes are involved. It is postulated that a compromised healing ability of the bone because of inhibition of bone turnover leads to sequestered osteomyelitis and necrosis. Studies have suggested that the risk of ONJ is greater in patients treated with zoledronic acid compared with pamidronate.<sup>1959,1960,1961</sup> Awareness of this problem has led to increased attention to oral hygiene and the avoidance of tooth extractions in the high-risk population of cancer patients receiving bisphosphonate treatment.

The risk of osteomyelitis and ONJ and face has been recognized for several years, but continues to be controversial. To be sure, most of the cases have been in cancer patients, usually treated with intravenous high doses, but this complication was also reported in patients receiving oral bisphosphonate treatment for osteoporosis, with no history or evidence of malignancy.<sup>1961,1962</sup> Experts in the field point out that many clinicians specializing in osteoporosis have never seen a case. **The incidence of ONJ with oral bisphosphonates is somewhere from 1 in 10,000 to 1 in 100,000.** They further argue that a true cause-and-effect relationship would require appropriate controlled studies, and two are ongoing. But clinical decision-making cannot be delayed until data are available, and it is by no means certain that the ongoing trials will yield definitive results on such a rare event. Patients should be cautioned regarding this rare problem and urged to practice good dental care. **We recommend consideration for dental evaluation and cleaning for patients in whom initiation of bisphosphonates for management of osteoporosis is being considered, prior to initiation of therapy, attention to oral hygiene during the course of treatment, and ongoing periodical surveillance.**<sup>1963</sup>

## **Bisphosphonates and Atrial Fibrillation**

An increase in the incidence of new-onset atrial fibrillation has been linked with the use of bisphosphonates, more so with intravenous than oral regimens.<sup>1964</sup> A meta-analysis presented at the meeting of the American College of Chest Physicians in October 2008 estimated that atrial fibrillation is observed in 2.5–3% of individuals treated with bisphosphonates and that 1–2% experience hospitalization or death. A case-control study concluded atrial fibrillation could be attributed to bisphosphonates in 3% of previous or current users.<sup>1965</sup> These positive reports were followed by a series of consistently negative studies. A larger Danish case-control study concluded that there

was no link between atrial fibrillation and the use of bisphosphonates.<sup>1966</sup> A Danish cohort study of fracture patients found no increase in the risks of stroke or myocardial infarction and concluded that an increase in atrial fibrillation could be attributed to the use of bisphosphonates in individuals already at increased risk for cardiovascular events.<sup>1967</sup> In two large American cohort databases of patients undergoing coronary angiography, there was no increase in atrial fibrillation or myocardial infarction associated with bisphosphonate treatment.<sup>1968</sup> A retrospective cohort study from Taiwan compared bisphosphonate use with the use of raloxifene and reported a similar rate of atrial fibrillation in both treatment groups.<sup>1969</sup> An apparent increase in atrial fibrillation can be attributed to the fact that most bisphosphonate users are older, have more cardiovascular disease, and are at greater risk for atrial fibrillation. Nonetheless, caution is advised in the elderly and those at risk, such as those with known hypertensive disorders, ischemic heart disease, cardiomyopathy, and valvular heart disease.

## **Bisphosphonates and Esophageal Cancer**

In a Letter to the Editor in the January 1, 2009, issue of the New England Journal of Medicine, the FDA reported 23 cases (8 fatal) of esophageal cancer in patients being treated with alendronate.<sup>1970</sup> As of 2009, a total of 31 cases of esophageal cancer had been collected in Europe and Japan associated with alendronate, risedronate, ibandronate, and etidronate. Although this is a small number of cases with drugs that have been used for more than a decade by millions of people, the concern has added credibility because of the well-recognized side effect of esophageal injury with oral bisphosphonates. Nevertheless, the FDA report was anecdotal in nature, with no comparison group. In response, American and European comparisons of treated patients to the U.S. expected incidence of esophageal cancer or to nontreated patients in national databases in the United Kingdom and Denmark failed to detect an increase in esophageal cancer in bisphosphonate-treated patients.<sup>1971,1972</sup> A meta-analysis of 11 studies published in 2015 was similarly reassuring and failed to identify any evidence to support an increase in risk of upper gastrointestinal cancers with the use of bisphosphonates.<sup>1973</sup>

## **Bisphosphonates and Pain**

The FDA has informed clinicians that patients taking bisphosphonates rarely experience severe bone, joint, or muscle pain that is relieved when treatment stops; discontinuation of bisphosphonate treatment and consideration for an alternative agent are advised in this setting.

---

## Key Points: Treatment with Bisphosphonates

- Bisphosphonate treatment is best reserved for older postmenopausal women. It is not a drug class of choice for the prevention of osteoporosis in relatively young postmenopausal women in whom hormone therapy may be preferentially considered as a first-line approach for osteoporosis prevention and fracture risk reduction.
- In all except very high-risk patients being treated with bisphosphonates, it would be wise to consider a time limit for duration of exposure. Bone density should be measured after 2–4 years of treatment, and a period of “drug holiday” should be considered after 5 years of use for those who are not deemed at a markedly high fracture risk. Patients should be followed by monitoring of bone density, with a resumption of treatment in those who rapidly lose bone or in those who accumulate a loss of 5–10% in 1 year.
- The onset of severe pain at any site is an indication to discontinue bisphosphonate treatment.
- In the absence of demonstrated fracture reduction benefit, the increased cost and likely increase in adverse events from a combination regimen (such as estrogen and bisphosphonate), such an approach is not currently recommended.

# Denosumab

Denosumab (Prolia) is a human monoclonal antibody to RANKL and is one of the newest of the available antifracture agents that was approved for the treatment of osteoporosis in high-risk patients. RANKL (nuclear factor kappa B ligand) is secreted by osteoblasts and binds to its receptor, RANK, on the surface of osteoclasts, stimulating the osteoclasts to mature and to resorb bone. OPG is a soluble receptor that is produced by the osteoblasts and that acts as a sponge to bind circulating RANKL, thereby preventing the RANK-mediated activation of osteoclasts; in the absence of RANK signaling, osteoclasts undergo apoptosis. An agent that could act like OPG, therefore, would prevent bone loss. Denosumab works like OPG, but rather than competing with RANK for its activator RANKL, it binds with great affinity to RANKL, thus preventing activation of RANK. The antiresorptive effects of denosumab are thus distinct from those of bisphosphonates and estrogens. Denosumab prevents both maturation and survival of osteoclasts and active bone resorption by osteoclasts.

The impact of denosumab on bone density has been evaluated in phase 2 clinical trials.<sup>1974</sup> The participants were postmenopausal women up to age 80 who had osteoporosis based on low T-scores. For the first 2 years, the patients were randomized to one of seven denosumab doses, alendronate, or placebo. After 2 years, patients in 5 of the treated groups were continued for 2 more years on 60 mg daily given subcutaneously only once every 6 months. One treatment arm was discontinued, and then after a year, treatment was resumed with 60 mg denosumab every 6 months. One treatment arm was discontinued after 2 years and followed. Two hundred and sixty-two women completed the study. Long-term treatment increased bone density in the spine and hip, whereas the placebo group continued to lose bone density. A reduction in markers for bone turnover was sustained. The group that discontinued treatment after 2 years lost bone density; after a year, retreatment with denosumab restored the bone to the level of the gain achieved in the first 2 years, levels similar to the groups who continued treatment for 4 years. No significant differences in the treatment and placebo groups were noted for adverse events. Similar results have been reported in a phase 3 trial with 332 women in 21 centers in Canada and the United States.<sup>1975</sup> In a large, 3-year, worldwide multicenter trial involving 7,868 women with osteoporosis, the Fracture Reduction Evaluation of Denosumab in Osteoporosis Every 6 Months (FREEDOM) trial, treatment with 60 mg denosumab subcutaneously every 6 months reduced vertebral fractures by 68%, hip fractures by 40%, and other nonvertebral fractures by 20%.<sup>1976</sup> A separate phase 3 trial concluded that denosumab treatment increased BMD at the hip and spine significantly more than alendronate.<sup>1977</sup> There were no differences in major adverse events in these trials, including osteonecrosis, or indications of suppressed immune function; however, eczema and cellulitis were



significantly increased in the worldwide study.<sup>1976</sup> The data representing 10 years of denosumab exposure (3 years of exposure in the FREEDOM trial plus 7-year exposure in the open-label extension study) offer reassurance regarding safety and efficacy of long-term use. Not only did the incidence of fractures in the long-term users remain comparable to that observed during the FREEDOM trial; additionally, there was evidence of ongoing improvement in BMD during the 10-year period of exposure. Adverse event profile was similarly comparable to that encountered in the 3-year FREEDOM trial.<sup>1978</sup>

How do the results compare with bisphosphonates? The increase in bone density at the spine and hip is greater with denosumab, and total body bone density, as exemplified by the radius, increases with denosumab, but not with bisphosphonates. **After discontinuation of denosumab, however bone loss begins immediately and the concept of drug holiday does not hold for denosumab. Prescribing information warns of the possibility of an increased risk of multiple vertebral fractures following discontinuation.**<sup>1979</sup> This quick reversibility contrasts with bisphosphonates which bind tightly to bone, remaining in bone for decades and maintaining a long-term effect. The 6-month dosing regimen of denosumab and subcutaneous route of administration offer convenience. Alternatively, the requirement for subcutaneous administration might seem to be an obstacle to some, but on the other hand, a required visit to the office might increase continuation rates. **Given that data on safety and ongoing efficacy of denosumab beyond 10 years of use are wanting, in our opinion, it is prudent to then consider switching to a bisphosphonate to ensure that the skeletal benefit gained from denosumab use persists beyond its discontinuation.**

# Calcitonin

Calcitonin regulates plasma calcium by inhibiting bone resorption and has been long recognized to offer fracture risk reduction. The antifracture efficacy of calcitonin is inferior to the agents discussed earlier. In a randomized 5-year trial, calcitonin treatment reduced spinal fractures with less of an effect (about 33%) compared with estrogen, alendronate, and raloxifene and had no reduction in hip fractures.<sup>1980</sup> Studies with intranasal delivery of salmon calcitonin (200 IU daily) indicate it can increase bone density. Human calcitonin is available, but recombinant salmon calcitonin (Fortical and Miacalcin) is more potent. Calcitonin treatment should be combined with vitamin D and calcium supplementation. The lack of a dose response and a high drop-out rate raised questions regarding the potency and efficacy of calcitonin in preventing fractures. Calcitonin however still has a place for use in patients who are unable to tolerate alternative agents, as well as for patients with intractable back pain, given its analgesic potential.<sup>1981</sup>

# Fluoride

The addition of fluoride, a potent stimulator of bone formation, can offer significant protection against osteoporosis. The clinical response depends on the formulation and dose. Slow-release sodium fluoride (25 mg b.i.d. given 12 of every 14 months) combined with calcium supplementation reduced the vertebral fracture rate with essentially no side effects.<sup>1982</sup> Treatment is recommended for no longer than 4 years to avoid the toxic accumulation of fluoride in bone.<sup>1983</sup> This treatment is reserved for patients with established postmenopausal osteoporosis; however, a commercial preparation has not yet been approved.

# Strontium

A divalent strontium salt of ranelic acid acts through uncoupling and rebalancing of the bone turnover in favor of net bone formation. A dose of 2 g of strontium ranelate is dissolved in water and taken at bedtime. Clinical trials indicate that a reduction in spinal and nonvertebral fractures is achieved comparable to antiresorptive agents.<sup>1984,1985</sup> Antifracture efficacy has been reported with up to 8 years of use. The main side effect is nausea and diarrhea that usually resolves in a few months. In pooled analyses, an increased risk of VTE was associated with strontium ranelate relative to placebo over 5 years of treatment, and ongoing caution is advised. Strontium is not approved for the management of osteoporosis in the United States, but oral strontium ranelate is available in many countries (Protelos, Protos, Protaxos, Bivalos, Osseor) for use in the management of osteoporosis.<sup>1986</sup>

# Tibolone

Tibolone is structurally related to the 19-nortestosterone progestins used clinically in oral contraceptives. Its chemistry, mechanisms of action, and clinical effects are discussed in detail earlier in this chapter. Tibolone prevents bone loss in postmenopausal women as effectively as estrogen or estrogen-progestin therapy.<sup>705,723,1987,1988,1989,1990,1991</sup> In a large U.S. dose-response study with doses ranging from 0.3 to 2.5 mg daily, only the 1.25- and 2.5-mg doses produced progressive bone density increases in the femoral neck. Indeed, the impact on bone was essentially the same for the two highest doses, 1.25 and 2.5 mg. Although the 1.25-mg dose is acceptable for the prevention of bone loss, the 2.5-mg dose is more effective for the alleviation of hot flashes.<sup>698</sup>

The beneficial impact on bone can be attributed to tibolone's estrogenic metabolites acting through the estrogen receptor because it is blocked by an antiestrogen, but not by an antiandrogen or an antiprogestin.<sup>1992</sup> Tibolone prevents the bone loss associated with GnRH agonist treatment (and the side effect of hot flushing).<sup>760,1993</sup> The BMD data are similar to those associated with hormonal and alendronate therapy.

The LIFT (Long-term Intervention on Fractures with Tibolone) study was a randomized, placebo-controlled multicenter trial in 22 countries of tibolone, 1.25 mg, given daily over 3 years.<sup>777</sup> The 4,538 women who participated in the trial were age 60–85, all at high risk of fractures because of osteoporosis, and all treated with calcium and vitamin D supplementation. The study was stopped in February 2006 after a mean treatment of 34 months because of an increased risk of stroke. The risks of all events were assessed after 5 years of follow-up. The reduction of fractures was about 4 times as great in women who already had a vertebral fracture upon entry to the study compared with women who had not had a fracture at baseline. It is noteworthy that the number of falls in the treated group was 25% less. The increase in stroke was greater in the oldest women (over age 70).

Based on previous bone density studies, the results of the LIFT trial on fracture reduction were not unexpected. The magnitude of the effect is roughly comparable to those with estrogen, bisphosphonates, and raloxifene (with the important exception being a lack of effect of raloxifene on hip fractures). A reduction of breast cancer was comparable to that reported with tamoxifen and raloxifene, but this was not a primary endpoint of the study.

The reported risk of stroke is similar to that observed with estrogen. In the WHI, no increase in stroke was observed in women under age 60 who had an absence of stroke risk factors. **It seems prudent to avoid the use of tibolone in elderly women and in women who are at risk for stroke** (specifically those with hypertension, smoking,

diabetes, or atrial fibrillation). The OPAL (Osteoporosis Prevention and Arterial effects of tibolone) study was a 3-year, randomized, double-blind trial in six U.S. centers and five European centers, treating 866 postmenopausal women with either 2.5 mg tibolone daily, 0.625/2.5 mg daily of conjugated estrogens/medroxyprogesterone acetate, or placebo.<sup>741</sup> Unfortunately, the OPAL trial did not achieve its goal of providing robust data on cardiovascular effects, due to the older age of the women and the notably different results in American and European women. There continues to be good reason to believe that tibolone will have a neutral effect in terms of CHD.

In summary, tibolone treatment of postmenopausal women is as effective as estrogen therapy in relieving hot flushes, preventing bone loss, and increasing vaginal lubrication and stimulates libido to a greater degree than estrogen. There is less breast tenderness and mastalgia with tibolone. Endometrial safety has been reported to be comparable to that achieved with continuous combined estrogen-progestin regimens and with a lower rate of breakthrough bleeding. The standard dose of tibolone for many years was 2.5 mg daily, but the new studies support the use of the lower dose, 1.25 mg, with no apparent loss of bone efficacy. Tibolone continues to be an appropriate choice for hormonal therapy, suitable for many postmenopausal women.

# Teriparatide

Parathyroid hormone increases bone formation. Teriparatide (Forteo) is the recombinant human 1–34 amino acid fragment of parathyroid hormone. Another Canadian preparation encompasses the 1–84 sequence. This is the only treatment, besides fluoride, that directly stimulates osteoblasts to form new bone. Given to postmenopausal women with osteoporosis in a once-daily, subcutaneous dose of 20 mg, teriparatide produces a greater increase in bone density and possibly a greater reduction in fractures compared with estrogen or alendronate.<sup>1994,1995</sup> Statistically significant reductions in both vertebral and nonvertebral fractures were observed in randomized controlled trials. A recent meta-analysis offers reassuring evidence of efficacy of teriparatide in reducing hip fractures by 56% in patients with osteoporosis.<sup>1996</sup> **Because of the expense and difficulty in self-administration, treatment with the parathyroid fragment is best directed to individuals with serious osteoporosis and at high risk for fractures.** After a relatively short period of treatment, no more than 2 years, the gain in bone can be maintained with one of the antiresorptive agents.<sup>1997,1998,1999,2000</sup>

# Alternative Therapies to Prevent Bone Loss

Phytoestrogens are effective in preventing bone loss in rats, but not in monkeys.<sup>2001,2002,2003</sup> In women, some studies demonstrated at best a slight effect on spinal bone, but most found no benefit in either the spine or hip.<sup>878,2004,2005,2006</sup> Flaxseed supplementation had no effect on biomarkers of bone metabolism.<sup>2007</sup> The difference between hip fracture incidence in Japanese and American women may be due to structural and/or genetic differences, not dietary intake of soy.<sup>2008</sup>

Ipriflavone is a synthetic isoflavone; it is methylated dehydroxydaidzein, which is metabolized to daidzein. Studies with ipriflavone demonstrated prevention of bone loss over a year.<sup>2009,2010,2011,2012</sup> Overall, the effect on bone was not as great as that observed with a standard dose of estrogen, or alendronate, perhaps not great enough to yield a benefit. A 4-year randomized trial in Europe assessed the effect of ipriflavone on bone density, urinary markers, and vertebral fractures in 474 women and could find no difference in the treated group compared with the placebo group.<sup>2013</sup>

Equol is a bacterial metabolite, and the only hormonally active metabolite, of the soy phytoestrogen, daidzein. At least in vitro, equol stimulates gene transcription with both estrogen receptors and with a greater potency than any other isoflavone.<sup>2014</sup> Equol formation is totally dependent on intestinal microflora. The most important observation regarding equol is that most adults do not produce equol, even when challenged with high doses of soy.<sup>934</sup> This is a contrast to nonhuman primates and other animals; all that have been studied produce high levels of equol. Thus, there are two human populations: equol producers and nonequol producers. The key question is whether equol producers receive greater clinical effects from phytoestrogens than nonequol producers. As noted, thus far the clinical effects of isoflavones on bone have not been impressive. In a 2-year randomized trial of postmenopausal women, isoflavone-rich soy milk increased spinal bone mass in the 45% of the subjects who were equol producers, with essentially no effect in nonequol producers.<sup>934</sup> Similar results were obtained in a Japanese trial testing the effect of isoflavone treatment in equol producers and nonproducers.<sup>2015</sup> Therefore, the population destined to receive a benefit from soy intake may be limited to equol producers. Studies need to be repeated measuring the responses in individuals who are identified as equol producers or nonequol producers. If the population destined to receive a benefit from soy intake is limited to equol producers, a convenient, inexpensive method must be developed to identify equol production. It may be possible to convert nonproducers to producers. A more straightforward approach is to administer equol itself. Daidzein yields two forms in equol producers, the R-equol inactive isomer and S-equol, the active isomer that binds to estrogen receptor- $\beta$ . S-equol has been synthesized and its administration is effective for the treatment of menopausal



symptoms.<sup>936</sup> Another alternative is the S-equol supplement made by incubating equol-producing bacteria with soy isoflavones.<sup>937,938</sup> It is absorbed readily with high bioavailability; low doses must be administered twice daily because of a relatively short half-life.

# Statins

Statin treatment is, of course, a mainstay in programs designed to prevent cardiovascular disease. Prompted by animal experiments indicating that statins increase bone formation, case-control studies reported that statin treatment was associated with a reduced risk of fracture.<sup>2016,2017</sup> However, analysis of a randomized trial of statin therapy and cardiovascular disease failed to detect an effect on fracture risk, and a cohort study reported that an apparent beneficial effect of statin on fracture risk was influenced by various confounding factors.<sup>2018,2019</sup> In the prospective cohort arm of the WHI, bone densities and fracture rates were similar comparing statin users with nonusers.<sup>2020</sup> A recent systematic review and meta-analysis assessed the efficacy of statins on bone density, on markers of bone turnover, and on fracture risk by examining data from 33 clinical trials.<sup>2021</sup> Statin use was associated with a decreased risk of overall fractures (OR = 0.81; 95% CI = 0.73–0.89) and hip fractures (OR = 0.75; 95% CI = 0.60–0.92). Statin use was associated with statistically significantly higher bone density parameters at the total hip and the lumbar spine and with improved bone formation marker, osteocalcin. Interestingly, skeletal benefits of statins demonstrated a gender differential being more robust in males compared to women users. **Based on existing evidence, statin users should be reassured regarding the potential for skeletal benefit, but statins should not replace proven effective medications to prevent or treat osteoporosis.**

# Thiazide Diuretics

Older women are often treated with thiazides for hypertension. Thiazides reduce the urinary loss of calcium and induce a positive calcium balance, and treatment is associated with a higher bone density. It is useful to know that estrogen and thiazides are additive; a significantly higher bone density is achieved with combined use.<sup>2022</sup> A recent meta-analysis that included 2,193,160 participants from 11 cohort studies evaluated the relationship between thiazide diuretic use and fracture. Users of thiazide diuretics experienced a statistically significant 14% reduction in the risk of all fractures and 18% reduction in risk of hip fracture compared to nonusers.<sup>2023</sup> **Based on existing evidence, users of thiazide diuretics should be reassured regarding the potential for skeletal benefit, but thiazides should not replace proven effective medications to prevent or treat osteoporosis.**

# Lifestyle Modifications

Lifestyle can have a beneficial effect on bone density as well as reduce fracture risk. Physical activity (weight-bearing), as little as 30 minutes a day for 3 days a week, will increase the mineral content of bone in older women.<sup>2024</sup> To be effective, exercise must exert a load on bone, especially the spine.<sup>2025</sup> Ordinary walking, while beneficial for balance and for overall health, alone will not suffice for improving bone density.<sup>2026</sup> Even brisk walking achieves a significant increase in bone density only in the calcaneus, the site subjected to stress with walking.<sup>2027</sup> However, brisk walking may slow the rate of bone loss in the hip.<sup>2028</sup> In other words, weight lifting is better for the spine than is ordinary walking, although running probably helps hip bone mass. The activities that are beneficial are running, weight training, aerobics, stair climbing, and sports other than swimming. The effect of weight-bearing exercise on bone density is additive when combined with hormone therapy.<sup>2029</sup> Although ordinary walking has little impact on bone density, it is still reasonable to expect walking to have an overall beneficial effect on the risk of fracture. Walking improves the cardiovascular status of patients and reduces body mass. These changes plus the exercise itself improve balance and decrease the risk of falling. For these reasons, walking, even after adjusting for bone density and body weight, is associated with a reduced risk of hip fracture.<sup>1807,2030</sup>

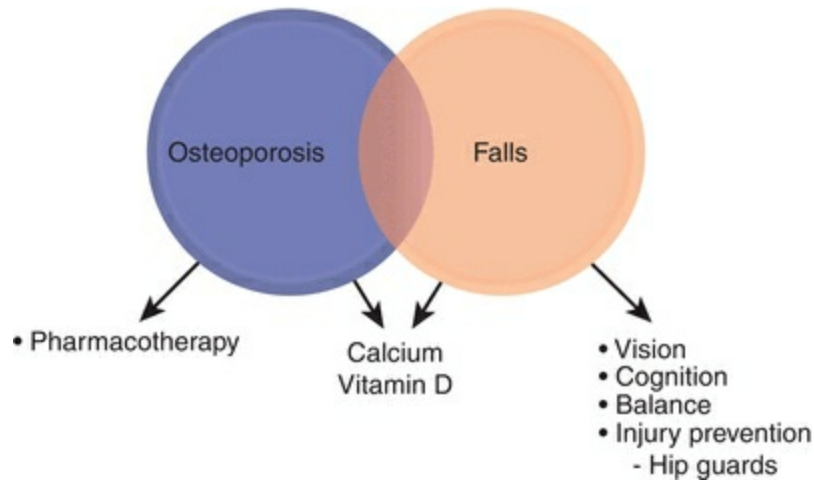
The impact of exercise on bone is significantly less than that achieved by hormone therapy.<sup>1876</sup> Women require the full combination of pharmacologic therapy, calcium and vitamin D supplementation, and exercise in order to minimize the risk of fractures. For each of these, the beneficial impact lasts only as long as the therapy is continued.

**Cigarette smoking and excessive alcohol consumption are associated with an increased risk of osteoporosis.** The magnitude of bone loss associated with cigarette smoking is consistent with a 40–45% increase in the risk of hip fracture.<sup>2031</sup> Women who smoke also enter menopause earlier and lose bone at a greater rate in the first years of the postmenopausal period.<sup>2032</sup>

A high coffee intake has been reported to be associated with an increased risk of osteoporosis.<sup>2033</sup> However, this increase in risk is dependent on dietary calcium intake. In women who drank at least one glass of milk (300 mg calcium) per day throughout most of their lives, increasing caffeinated coffee intake was not associated with a lower bone density.<sup>2034</sup> Repeatedly, we see the importance of teaching children and adolescents the merit of an adequate calcium intake; drinking nonfat milk throughout life is good for you. An adequate calcium intake compensates for “calcium robbers,” such as caffeine and soft drinks. A British study concluded that an increase of only 300 mL of milk per day in adolescents increased bone density without an increase in weight or

body fat.<sup>1881</sup>

**Remember that not all fractures are solely due to osteoporosis.** Drug side effects, impaired vision, neurologic dysfunction, and muscular conditions all put patients at risk because more than 90% of fractures occur following a fall<sup>1755</sup> (**Figure 17.25**).



Data from **McClung MR**, Do current management strategies and guidelines adequately address fracture risk? *Bone* 38(2 Suppl 2):S13, 2006.

Interventions that reduce the odds of falling and enhance the ability to withstand the impact of a fall are important.<sup>2035</sup> This includes patient education regarding hazards in the home, monitoring drug use, adequate nutrition, and a good exercise program. In addition, there is evidence that estrogen with or without added progestin improves muscle strength and balance.<sup>268,269,270,271,272,273</sup> On the other hand, some studies have not been able to document an increase in muscle strength or improvements in balance.<sup>2029,2036,2037,2038,2039</sup> Furthermore, the increase in muscle mass and strength in response to weight-bearing exercise was the same when hormone users were compared with nonusers.<sup>2040</sup> Nevertheless, a cohort study reported 71% fewer falls in early postmenopausal hormone users and 43% in late postmenopausal hormone users.<sup>2041</sup> Use of hip guards has been shown to reduce risk of hip fractures in institutionalized elderly, but not in ambulant populations.<sup>2042</sup>

# Bone-Losing Medications

Clinicians should always remember that exposure to excessive thyroid and glucocorticoid hormones is associated with osteoporosis and an increased rate of fractures. The bone loss associated with glucocorticoid treatment is significantly prevented by hormone or bisphosphonate therapy.<sup>2043,2044,2045,2046</sup> **Excessive thyroid effects can be avoided by periodic (at least annually) monitoring treatment dosage with TSH levels.** Specific preventive treatment should also be offered to patients using long-term anticonvulsants or heparin.

Considerable publicity has successfully raised clinical consciousness regarding the increased risk of fractures associated with the use of corticosteroids. We should similarly recognize the increased risk of fractures with the daily use of SSRIs. The Canadian Multicentre Osteoporosis Study Research Group reported the effect of daily SSRIs in a prospective cohort study in seven regional centers of 5,008 adults over the age of 50.<sup>1793</sup> After adjusting for age, hip bone density, fractures at baseline, and estrogen use in women, daily SSRI use was associated with a twofold increased risk of fragility fractures. Daily use of SSRIs was also associated with about a twofold increased risk of falling, and these individuals had lower bone densities. Controlling for falls and lower bone density still left an increased risk of fractures in SSRI users that began after 1–1.5 years of use.

Does this side effect of SSRIs make sense? Is it the SSRI or the lifestyle associated with clinical depression? Serotonin does not cross the blood-brain barrier; in the brain, serotonin activity is the result of synthesis, reuptake, and binding to a 5-hydroxytryptophan receptor, which is inhibited by SSRIs. Most of the circulating serotonin comes from synthesis in the duodenum by specialized neuroendocrine cells. Locally released serotonin stimulates intestinal peristalsis, whereas the serotonin entering the circulation is taken up by platelets or serotonin can reach a target tissue like bone, linking bone formation to the gut. Mice with a mutation for the serotonin transporter protein develop less bone mass and strength.<sup>1794</sup> Serotonin receptors and serotonin transport have been identified in osteoblasts and osteocytes. The bone effects of parathyroid hormone and mechanical stimulation are modulated by the serotonin system. Therefore, daily SSRI use can impair bone formation, tilting the balance in favor of resorption and bone loss, and decreased bone densities have been reported in both male and female SSRI users (but not in users of tricyclic antidepressants).<sup>1795,1796</sup>

It is not always easy to know which came first, depression or fractures, leading to subsequent depression. It has been reported that depressed people and SSRI users have a greater incidence of falls,<sup>1788</sup> and thus it is not unreasonable to consider that depression comes first in some people. However, orthostatic hypotension and syncope

are more common in SSRI users, and this could also contribute to the greater prevalence of falls.

Depressed people are sedentary and eat poorly, factors that favor bone loss. Some have speculated that increased cortisol levels associated with depression might lead to bone loss, similar to that observed with the pharmacologic administration of corticosteroids. On the other hand, American studies, despite finding a link between depression and fractures, failed to detect an increase in depression associated with lower bone density measurements.<sup>1787,1788</sup> However, other studies have reported increases in depression associated with lower bone densities.<sup>1789,1790,1791</sup>

Obviously, this is an unsettled picture, but we should be more aware of the possible increased risk of fractures with the daily use of SSRIs. Interventions that reduce the odds of falling and enhance the ability to withstand the impact of a fall are important. This includes patient education regarding hazards in the home, monitoring drug use, adequate nutrition, and a good exercise program. Aggressive monitoring of bone density is warranted; adequate calcium and vitamin D supplementation are necessary, and until more studies clarify this problem, it seems reasonable to consider treatment with one of the antiresorptive agents.

Proton pump–inhibiting drugs used to treat gastroesophageal reflux impair intestinal calcium absorption, resulting in secondary hyperparathyroidism and bone loss. Long-term use of omeprazole has been linked to an increase in hip fractures in case-control studies.<sup>2047,2048</sup> These drugs should be added to the list of bone-losing medications that require careful monitoring of bone density and antiresorptive treatment when indicated. The list includes, of course, any treatment that produces a hypoestrogenic state, for example, an aromatase inhibitor.

Thiazolidinediones used to treat diabetes are associated with an increase in bone loss and fractures.<sup>2049,2050</sup> Bone density measurements and careful assessment for fracture risk are important components of health care for these diabetic women, with emphasis on adequate calcium and vitamin D supplementation and appropriate treatment with one of the antiresorptive agents where indicated.

## Key Points: Bone-Losing Medications

- Glucocorticoid treatment (more than 3 months)
- Exposure to excessive thyroxine (suppressed TSH levels)
- SSRI therapy for depression
- Proton pump–inhibiting drugs
- Aromatase inhibitors

- Thiazolidinediones



# Management of a Nonresponder

**Response to treatment is assessed by repeating BMD assessment.** Treatment efficacy is reflected in stable or improved BMD repeated at a minimum interval of 1 year from baseline study. **It is important to appreciate that the number to focus on when assessing interval change is of the actual BMD that is reported in  $\text{g/cm}^2$ , and not the T-scores.** There are two reasons to question the prevalence of nonresponse to treatment. The first reason is the argument that the results of single bone density measurements display the phenomenon of regression to the mean (extreme results are in part due to random error). Analysis of the hip and spinal bone density data from the randomized clinical trials assessing the effects of alendronate and raloxifene in postmenopausal women with osteoporosis revealed that women who lost BMD after 1 year of treatment were likely to gain bone during the second year.<sup>2051</sup> The more extreme the measurement after 1 year of treatment, the more likely the next year's measurement indicated a reversal. Therefore, it has been recommended that bone treatments should not be discontinued when measurements after 1 year indicate loss of bone density because repeat results are usually closer to the mean. Once a lack of response is identified based on repeat bone density assessment, the next step should be to inquire about compliance, particularly with prescribed oral agents, and assess serum 25-hydroxyvitamin D and calcium levels as vitamin D deficiency is a common mechanism for failure of antifracture treatments. Optimal vitamin D levels are necessary to maximize the response to any antiresorption agent.<sup>2052</sup> This emphasizes the need to titer the dose of vitamin D supplementation by measuring the circulating level of 25-hydroxyvitamin D. A value less than 30 ng/mL is below normal; less than 20 ng/mL is a definitive indication of vitamin D deficiency. Assessment of bone turnover markers can allow insights into compliance as well as effectiveness as a minimum of 30% reduction in markers of bone resorption should occur with the use of estrogens, raloxifene, bisphosphonates, and denosumab.

**We advocate monitoring of treatment response with the use of repeat bone density measurements, as well as support a consideration of assessing bone markers within 1–3 months following initiation of antifracture therapy to reflect compliance and treatment efficacy, at least in the short term. Clinicians must be aware that interpretation of treatment efficacy must be based on BMD ( $\text{g/cm}^2$ ), and not T-scores (Table 17.20).**

## TABLE 17.20 Is Antifracture Treatment Working?

## **Bone mineral density monitoring**

- A minimal time interval of 1 y is needed to allow detection of any meaningful change in bone density
- Use the same device and facility if feasible
- Compare absolute bone mass ( $\text{g}/\text{cm}^2$ ) and not T-scores
- Pay attention to the facility and devise specific least significant difference (LSD) to determine if interval change is of clinical relevance
- Consider lateral imaging if suspecting vertebral fracture

---

## **Monitoring using bone markers?**

- Can be considered in patients where concern for noncompliance or lack of efficacy is high
  - If checked before starting treatment and 3 mo after treatment is initiated, a >30% change (drop) is consistent with compliance and suggests treatment efficacy
-

# Assessing Blood Estrogen Levels in Hormone Users

On the average, about 10–15% of women may lose bone despite being prescribed hormone therapy. **Because of the precision error with bone density measurements, a change of at least 3–5% is necessary to be clinically significant.** A Finnish 5-year clinical trial reported a prevalence of poor response based on bone density of 11% for spinal bone and 26% for the hip.<sup>2053</sup> As expected, smoking and low body weight were common findings among the poor responders, but the most impressive characteristics were lower estradiol and higher FSH levels. It is only logical that there exists a group of women who metabolize and clear administered estrogens at a greater rate and thus require a higher dose to sustain a protective effect on bone. Indeed, considerable variation in estradiol levels has been documented in individuals receiving both oral and transdermal hormone therapies.<sup>504,2054</sup> Marketing presentations by the pharmaceutical companies provide mean levels, suggesting stable and smooth maintenance of blood levels; however, the ranges, which are wide, are not revealed. An aim of individualizing hormone therapy is to determine the appropriate dose for the intended objective; in the case of bone, antiresorptive effects are apparent when serum estradiol levels exceed 20 pg/mL and are optimized with estradiol in 40–60 pg/mL range. In patients using hormone therapy for osteoporosis prevention or management, if repeat bone density assessment demonstrates evidence of ongoing bone loss, proceeding with assessing serum estradiol level is an appropriate next step. A practical range for a blood sample derived during office hours from a patient taking her medication at night is 50–100 pg/mL. To minimize variation, we encourage clinicians to always use the same laboratory, after first establishing the values obtained using standard doses of estradiol in their own practices. The reliability of blood estrogen measurements is questionable when CEEs are the treatment being used, although some assays can provide reproducible results because of cross-reactions with the specific antibody in the assay.

As clinicians and the pharmaceutical industry promote lower doses of estrogen in order to minimize estrogen-related risks, a greater rate of poor response as measured by bone density can be expected. For otherwise healthy women without significant risk for cerebrovascular and cardiovascular harm, up-titration of estrogen dose can be safely considered if evidence of lack of skeletal response is encountered. Safety of such an approach can be ensured by monitoring of serum concentrations of estradiol. We would further emphasize that appropriate detection and investigation will confirm that a relatively low blood estradiol level is the cause of most cases of poor bone response to hormone treatment. An acidic vaginal pH (<4.5) correlates with an appropriate dose of estrogen administration and is a very simple and inexpensive way of assessing

adequacy of dosing.<sup>242,539</sup>

**In a woman demonstrated to be losing bone despite hormone therapy, the following steps are recommended as shown in [Table 17.21](#).**

## **TABLE 17.21 Recommendations for Losing Bone Despite Hormone Therapy**

**1. Check compliance and dose by measuring blood estrogen levels; adjust dose titration based on serum estradiol measurements. Consider the use of vaginal pH measurements**

---

**2. Rule out other causes of bone loss**

*Chronic disease:*

- Renal and hepatic
- Multiple myeloma

*Endocrine diseases:*

- Excess glucocorticoids
- Hyperthyroidism
- Hyperparathyroidism
- Inadequate estrogen dosing

*Drugs:*

- Heparin, anticonvulsants, glucocorticoids
- SSRIs, proton pump inhibitors, thiazolidinediones

*Nutritional:*

- Calcium, phosphate, vitamin D deficiencies

*Toxic exposures:*

- High intake of alcohol
- Smoking

---

**3. Follow with markers of bone turnover or bone density measurements**

---

# CONCLUSION

---

The menopause is a physiologic event that brings clinicians and patients together, providing the opportunity to enroll patients in health maintenance. The failure to respond appropriately (by either clinician or patient) easily leads to a loss of the patient from a practice, but equally, if not more, importantly, is the probability that the loss of a patient from a practice means that another woman has lost her involvement in a preventive health care program. Menopause must not be perceived as a signal of impending decline, but, rather, is a new chapter in life that is to be welcomed and better planned to ensure good health and optimal well-being in the years ahead.

# REFERENCES

1. **Farnham AM**, Uterine disease as a factor in the production of insanity, *Alienist Neurologist* 8:532, 1887.
2. **Hällström T, Samuelsson S**, Mental health in the climacteric. The longitudinal study of women in Gothenburg, *Acta Obstet Gynecol Scand Suppl* 130:13, 1985.
3. **McKinlay SM, McKinlay JB**, The impact of menopause and social factors on health, In: Hammond CB, Haseltine FP, Schiff I, eds. *Menopause: Evaluation, Treatment, and Health Concerns*, Alan R. Liss, New York, 1989, pp. 137–161.
4. **Matthews KA, Wing RR, Kuller LH, Meilahn EN, Kelsey SF, Costello EJ, Caggiula AW**, Influences of natural menopause on psychological characteristics and symptoms of middle-aged healthy women, *J Consult Clin Psychol* 58:345, 1990.
5. **Koster A**, Change-of-life anticipations, attitudes, and experiences among middle-aged Danish women, *Health Care Women Int* 12:1, 1991.
6. **Holte A**, Influences of natural menopause on health complaints: a prospective study of healthy Norwegian women, *Maturitas* 14:127, 1992.
7. **Kaufert PA, Gilbert P, Tate R**, The Manitoba Project: a re-examination of the link between menopause and depression, *Maturitas* 14:143, 1992.
8. **Dennerstein L, Smith AMA, Morse C, Burger H, Green A, Hopper J, Ryan M**, Menopausal symptoms in Australian women, *Med J Aust* 159:232, 1993.
9. **Dennerstein L, Lehert P, Burger HG, Dudley E**, Mood and the menopause transition, *J Nerv Ment Dis* 187:685, 1999.
10. **Smith-DiJulio K, Woods NF, Mitchell ES**, Well-being during the menopausal transition and early postmenopause: a within-stage analysis, *Womens Health Issues* 18:310, 2008.
11. **Woods NF, Mitchell ES, Percival DB, Smith-DiJulio K**, Is the menopausal transition stressful? Observations of perceived stress from the Seattle Midlife Women's Health Study, *Menopause* 16:90, 2009.
12. **Avis NE, McKinlay SM**, A longitudinal analysis of women's attitudes toward the menopause: results from the Massachusetts Women's Health Study, *Maturitas* 13:65, 1991.
13. **Morse CA, Smith A, Dennerstein L, Green A, Hopper J, Burger H**, The treatment-seeking woman at menopause, *Maturitas* 18:161, 1994.
14. **Defey D, Storch E, Cardozo S, Diaz O, Fernandez G**, The menopause: women's psychology and health care, *Soc Sci Med* 42:1447, 1996.
15. **Heron MP, Hoyert DL, Xu J, Scott C, Tejada-Vera B**, Deaths: preliminary data for 2006, *Natl Vital Stat Rep* 56(No. 16):1, 2008.
16. **U.S. National Center for Health Statistics**, Health, United States, 2016, <http://www.ced.gov/nchs>, 2016.
17. **Olshansky SJ, Carnes BA, Cassel C**, In search of Methuselah: estimating the upper limits to human longevity, *Science* 250:634, 1990.
18. **Olshansky SJ, Carnes BA, Cassel C**, The aging of the human species, *Sci Am* 268(4):46, 1993.
19. **Hobbs FB**, Population Profile of the United States, U.S. Census Bureau, <http://www.census.gov/population/www/pop-profile/elderpop.html>, 2009.
20. **United Nations**, World population to exceed 9 billion by 2050, <http://www.un.org/esa/population/unpop.htm>, 2009.
21. **McDevitt TM, Stanecki KA, Way PO**, Report WP/98, World Population Profile: 1998, Washington, DC: US Census Bureau; 1999.
22. **Hetzel L, Smith A**, Census 2000 BriefC2KBR/01-10: The 65 Years and Over Population: 2000, Washington, DC: US Census Bureau; 2004.
23. **Miles TP, Bernard MA**, Morbidity, disability, and health status of black American elderly: a new look at the oldest-old, *J Am Geriatr Soc* 40:1047, 1992.
24. **Day JC**, Bureau of the Census, Current Population Reports, Population Projections of the United States, by Age, Sex, Race, and Hispanic Origin: 1993 to 2050, U.S. Government Printing Office, Washington, 1993.

25. **Centers for Disease Control and Prevention, U.S. Department of Health and Human Services**, Women and smoking: a report of the surgeon general, *Morb Mortal Wkly Rep* 51(RR12):1, 2002.
26. **Annual Report of the Board of Trustees of the Federal Old-Age and Survivors Insurance and Disability Insurance Trust Funds**, Report No. Tbl II.D2, U.S. Government Printing Office, 1995.
27. Centers for Disease Control and Prevention, [www.cdc.gov/nchs/data/ad/ad272.pdf](http://www.cdc.gov/nchs/data/ad/ad272.pdf), 2003.
28. **Keith PM**, The social context and resources of the unmarried in old age, *Int J Aging Hum Dev* 23:81, 1986.
29. **Fries JF, Crapo LM**, *Vitality and Aging*, W.H. Freeman and Co., San Francisco, 1981.
30. **Fries JF**, The sunny side of aging, *JAMA* 263:2354, 1990.
31. **Fries JF**, Strategies for reduction of morbidity, *Am J Clin Nutr* 55:1257S, 1992.
32. **Nelson DE, Giovino GA, Emont SL, Brackbill R, Cameron LL, Peddicord J, Mowery PD**, Trends in cigarette smoking among US physicians and nurses, *JAMA* 271:1273, 1994.
33. **Davis DL, Dinse GE, Hoel DG**, Decreasing cardiovascular disease and increasing cancer among whites in the United States from 1973 through 1987, *JAMA* 271:431, 1994.
34. **Willett WC, Green A, Stampfer MJ, Speizer FE, Colditz GA, Rosner B, Monson RR, Stason W, Hennekens CH**, Relative and absolute excess risks of coronary heart disease among women who smoke cigarettes, *N Engl J Med* 317:1303, 1987.
35. **Jha P, Ramasundarathetigge C, Landsman V, Rostron B, Thun M, Anderson RN, McAfee T, Peto R**, 21st century hazards of smoking and benefits of cessation in the United States, *N Engl J Med* 368(4):341, 2013.
36. **Kenfield SA, Stampfer MJ, Rosner BA, Colditz GA**, Smoking and smoking cessation in relation to mortality in women, *JAMA* 299:2037, 2008.
37. **Hermanson B, Omenn GS, Kronmal RA, Gersh BJ**, Beneficial six-year outcome of smoking cessation in older men and women with coronary artery disease. Results from the CASS registry, *N Engl J Med* 319:1365, 1988.
38. **Ebbert JO, Yang P, Vachon CM, Vierkant RA, Cerhan JR, Folsom AR, Sellers TA**, Lung cancer risk reduction after smoking cessation: observations from a prospective cohort of women, *J Clin Oncol* 21:921, 2003.
39. **Soules MR, Sherman S, Parrott E, Rebar R, Santoro N, Utian W, Woods N**, Executive summary: Stages of Reproductive Aging Workshop (STRAW), *Climacteric* 4(4):267, 2001.
40. **Harlow SD, Gass M, Hall JE, Lobo R, Maki P, Rebar RW, Sherman S, Sluss PM, de Villiers TJ; STRAW + 10 Collaborative Group**, Executive summary of the Stages of Reproductive Aging Workshop + 10: addressing the unfinished agenda of staging reproductive aging, *Climacteric* 15(2):105, 2012.
41. **Harlow SD, Gass M, Hall JE, Lobo R, Maki P, Rebar RW, Sherman S, Sluss PM, de Villiers TJ; STRAW + 10 Collaborative Group**, Executive summary of the Stages of Reproductive Aging Workshop + 10: addressing the unfinished agenda of staging reproductive aging, *Fertil Steril* 97(4):843, 2012.
42. **Harlow SD, Mitchell ES, Crawford S, Nan B, Little R, Taffe J; for the ReSTAGE Collaboration**, The ReSTAGE Collaboration: defining optimal bleeding criteria for onset of early menopausal transition, *Fertil Steril* 89:129, 2008.
43. **Vollman RF**, The menstrual cycle, In: Friedman E, ed. *Major Problems in Obstetrics and Gynecology*, W.B. Saunders Co., Philadelphia, 1977.
44. **Treloar AE, Boynton RE, Borghild GB, Brown BW**, Variation of the human menstrual cycle through reproductive life, *Int J Fertil* 12:77, 1967.
45. **Cole LA, Ladner DG, Byrn FW**, The normal variabilities of the menstrual cycle, *Fertil Steril* 91(2):522, 2009.
46. **Collett ME, Wertenberger GE, Fiske VM**, The effect of age upon the pattern of the menstrual cycle, *Fertil Steril* 5:437, 1954.
47. **Chiazze L Jr, Brayer FT, Macisco JJ Jr, Parker MP, Duffy BJ**, The length and variability of the human menstrual cycle, *JAMA* 203:377, 1968.
48. **Munster K, Schmidt L, Helm P**, Length and variation in the menstrual cycle—a cross-sectional study from a Danish county, *Br J Obstet Gynaecol* 99:422, 1992.
49. **Belsey EM, Pinol APY; Task Force on Long-Acting Systemic Agents for Fertility Regulation**, Menstrual bleeding patterns in untreated women, *Contraception* 55:57, 1997.



50. **Ferrell RJ, Simon JA, Pincus SM, Rodríguez G, O'Connor KA, Holman DJ, Weinstein M**, The length of perimenopausal menstrual cycles increases later and to a greater degree than previously reported, *Fertil Steril* 86:619, 2006.
51. **Taffe JR, Dennerstein L**, Menstrual patterns leading to the final menstrual period, *Menopause* 9:32, 2002.
52. **den Tonkelaar I, te Velde ER, Looman CWN**, Menstrual cycle length preceding menopause in relation to age at menopause, *Maturitas* 29:115, 1998.
53. **Sherman BM, West JH, Korenman SG**, The menopausal transition: analysis of LH, FSH, estradiol, and progesterone concentrations during menstrual cycles of older women, *J Clin Endocrinol Metab* 42:629, 1976.
54. **Lenton EA, Landgren B, Sexton L, Harper R**, Normal variation in the length of the follicular phase of the menstrual cycle: effect of chronological age, *Br J Obstet Gynaecol* 91:681, 1984.
55. **Buckler HM, Evans A, Mamlora H, Burger HG, Anderson DC**, Gonadotropin, steroid and inhibin levels in women with incipient ovarian failure during anovulatory and ovulatory 'rebound' cycles, *J Clin Endocrinol Metab* 72:116, 1991.
56. **MacNaughton J, Bangah M, McCloud P, Hee J, Burger HG**, Age-related changes in follicle stimulating hormone, luteinizing hormone, oestradiol and immunoreactive inhibin in women of reproductive age, *Clin Endocrinol* 36:339, 1992.
57. **Hee J, MacNaughton J, Bangah M, Burger HG**, Perimenopausal patterns of gonadotrophins, immunoreactive inhibin, oestradiol and progesterone, *Maturitas* 18:9, 1993.
58. **Metcalf MG, Livesay JH**, Gonadotropin excretion in fertile women: effect of age and the onset of the menopausal transition, *J Endocrinol* 105:357, 1985.
59. **Rannevik G, Jeppsson S, Johnell O, Bjerre B, Yaurell-Borulf Y, Svanberg L**, A longitudinal study of the perimenopausal transition: altered profiles of steroid and pituitary hormones, SHBG and bone mineral density, *Maturitas* 21:103, 1995.
60. **Burger HG, Dudley EC, Hopper JL, Groome N, Guthrie JR, Green A, Dennerstein L**, Prospectively measured levels of serum follicle-stimulating hormone, estradiol, and the dimeric inhibins during the menopausal transition in a population-based cohort of women, *J Clin Endocrinol Metab* 84:4025, 1999.
61. **Burger HG, Hale GE, Dennerstein L, Robertson DM**, Cycle and hormone changes during perimenopause: the key role of ovarian function, *Menopause* 15:603, 2008.
62. **O'Connor KA, Ferrell R, Brindle E, Trumble B, Shofer J, Holman DJ, Weinstein M**, Progesterone and ovulation across stages of the transition to menopause, *Menopause* 16:1178, 2009.
63. **Treloar AE**, Menstrual cyclicity and the pre-menopause, *Maturitas* 3:249, 1981.
64. **van Noord PAH, Dubas JS, Dorland M, Boersma H, te Velde E**, Age at natural menopause in a population-based screening cohort: the role of menarche, fecundity, and lifestyle factors, *Fertil Steril* 68:95, 1997.
65. **Burger HG, Dudley E, Manners P, Groome N, Robertson DM**, Early follicular phase serum FSH as a function of age: the roles of inhibin B, inhibin A and estradiol, *Climacteric* 3:17, 2000.
66. **Lasley BL, Santoro N, Randolph JF, Gold EB, Crawford S, Weiss G, McConnell DS, Sowers MF**, The relationship of circulating dehydroepiandrosterone, testosterone, and estradiol to stages of the menopausal transition and ethnicity, *J Clin Endocrinol Metab* 87:3760, 2002.
67. **Santoro N, Brown JR, Adel T, Skurnick JH**, Characterization of reproductive hormonal dynamics in the perimenopause, *J Clin Endocrinol Metab* 81:1495, 1996.
68. **Meyer PM, Zeger SL, Harlow SD, Sowers M, Crawford S, Luborsky JL, Janssen I, McConnell DS, Randolph JF, Weiss G**, Characterizing daily urinary hormone profiles for women at midlife using functional data analysis, *Am J Epidemiol* 165:936, 2007.
69. **Richardson SJ, Senikas V, Nelson JF**, Follicular depletion during the menopausal transition—evidence for accelerated loss and ultimate exhaustion, *J Clin Endocrinol Metab* 65:1231, 1987.
70. **Gougeon A, Echiohard R, Thalabard JC**, Age-related changes of the population of human ovarian follicles: increase in the disappearance rate of non-growing and early-growing follicles in aging women, *Biol Reprod* 50:653, 1994.
71. **Faddy MJ, Gosden RG, Gougeon A, Richardson SJ, Nelson JF**, Accelerated disappearance of ovarian

- follicles in mid-life: implications for forecasting menopause, *Hum Reprod* 7:1342, 1992.
72. **Klein NA, Illingworth PJ, Groome NP, McNeilly AS, Battaglia DE, Soules MR**, Decreased inhibin B secretion is associated with the monotropic FSH rise in older, ovulatory women: a study of serum and follicular fluid levels of dimeric inhibin A and B in spontaneous menstrual cycles, *J Clin Endocrinol Metab* 81:2742, 1996.
  73. **Danforth DR, Arbogast LK, Mroueh J, Kim MH, Kennard EA, Seifer DB, Friedman CI**, Dimeric inhibin: a direct marker of ovarian aging, *Fertil Steril* 70:119, 1998.
  74. **Welt CK, McNicholl DJ, Taylor AE, Hall JE**, Female reproductive aging is marked by decreased secretion of dimeric inhibin, *J Clin Endocrinol Metab* 84:105, 1999.
  75. **Seifer DB, Gardiner AC, Ferreira KA, Peluso JJ**, Apoptosis as a function of ovarian reserve in women undergoing in vitro fertilization, *Fertil Steril* 66:593, 1996.
  76. **Klein NA, Battaglia DE, Miller PB, Branigan EF, Giudice LC, Soules MR**, Ovarian follicular development and the follicular fluid hormones and growth factors in normal women of advanced reproductive age, *J Clin Endocrinol Metab* 81:1946, 1996.
  77. **Klein NA, Battaglia DE, Fujimoto VY, Davis GS, Bremmer WJ, Soules MR**, Reproductive aging: accelerated ovarian follicular development associated with a monotropic follicle-stimulating hormone rise in normal older women, *J Clin Endocrinol Metab* 81:1038, 1996.
  78. **Klein NA, Harper AJ, Houmard BS, Sluss PM, Soules MR**, Is the short follicular phase in older women secondary to advanced or accelerated dominant follicle development?, *J Clin Endocrinol Metab* 87:5746, 2002.
  79. **van Zonneveld P, Scheffer GJ, Broekmans FJ, Blankenstein MA, de Jong FH, Looman CW, Habbema JD, te Velde ER**, Do cycle disturbances explain the age-related decline of female fertility? Cycle characteristics of women aged over 40 years compared with a reference population of young women, *Hum Reprod* 18:495, 2003.
  80. **Lass A, Silye R, Abrams D-C, Krausz T, Hovatta O, Margara R, Winston RML**, Follicular density in ovarian biopsy of infertile women: a novel method to assess ovarian reserve, *Hum Reprod* 12:1028, 1997.
  81. **Lass A, Skull J, McVeigh E, Margara R, Winston RM**, Measurement of ovarian volume by transvaginal sonography before human menopausal gonadotrophin superovulation for in-vitro fertilization can predict poor response, *Hum Reprod* 12:294, 1997.
  82. **Yong PY, Baird DT, Thong KJ, McNeilly AS, Anderson RA**, Prospective analysis of the relationships between the ovarian follicle cohort and basal FSH concentration, the inhibin response to exogenous FSH and ovarian follicle number at different stages of the normal menstrual cycle and after pituitary down-regulation, *Hum Reprod* 18:35, 2003.
  83. **Frattarelli JL, Lauria-Costab DF, Miller BT, Bergh PA, Scott RT**, Basal antral follicle number and mean ovarian diameter predict cycle cancellation and ovarian responsiveness in assisted reproductive technology cycles, *Fertil Steril* 74:512, 2000.
  84. **Dumesic DA, Damario MA, Session DR, Famuyide A, Lesnick TG, Thornhill AR, McNeilly AS**, Ovarian morphology and serum hormone markers as predictors of ovarian follicle recruitment by gonadotropins for in vitro fertilization, *J Clin Endocrinol Metab* 86:2538, 2001.
  85. **Bancsi LF, Broekmans FJ, Eijkemans MJ, de Jong FH, Habbema JD, te Velde ER**, Predictors of poor ovarian response in in vitro fertilization: a prospective study comparing basal markers of ovarian reserve, *Fertil Steril* 77:328, 2002.
  86. **Kupesic S, Kurjak A, Bjelos D, Vujisic S**, Three-dimensional ultrasonographic ovarian measurements and in vitro fertilization outcome are related to age, *Fertil Steril* 79:190, 2003.
  87. **Sowers MR, Zheng H, McConnell D, Nan B, Harlow S, Randolph JF Jr**, Follicle stimulating hormone and its rate of change in defining menopause transition stages, *J Clin Endocrinol Metab* 93:3958, 2008.
  88. **Sowers MR, Zheng H, McConnell D, Nan B, Harlow SD, Randolph JF Jr**, Estradiol rates of change in relation to the final menstrual period in a population-based cohort of women, *J Clin Endocrinol Metab* 93:3847, 2008.
  89. **Sowers MR, Eyvazzadeh AD, McConnell D, Yosef M, Jannausch ML, Zhang D, Harlow SD, Randolph JF Jr**, Anti-müllerian hormone and inhibin B in the definition of ovarian aging and the menopause transition, *J Clin Endocrinol Metab* 93:3478, 2008.

90. **Depmann M, Eijkemans MJ, Broer SL, Scheffer GJ, van Rooij IA, Laven JS, Broekmans FJ**, Does anti-Müllerian hormone predict menopause in the general population? Results of a prospective ongoing cohort study, *Hum Reprod* 31(7):1579, 2016.
91. **Visser JA, De Jong FH, Laven JS, Themmen AP**, Anti-müllerian hormone: a new marker for ovarian function, *Reproduction* 131:1, 2006.
92. **Randolph JF Jr, Crawford S, Dennerstein L, Cain K, Harlow SD, Little R, Mitchell ES, Nan B, Taffe J, Yosef M**, The value of follicle-stimulating hormone concentration and clinical findings as markers of the late menopausal transition, *J Clin Endocrinol Metab* 91:3034, 2006.
93. **McKinlay SM, Brambilla DJ, Posner JG**, The normal menopause transition, *Maturitas* 14:103, 1992.
94. **McKinlay SM, Bigano NL, McKinlay JB**, Smoking and age at menopause, *Ann Intern Med* 103:350, 1985.
95. **Treolar AE**, Menarche, menopause and intervening fecundability, *Hum Biol* 46:89, 1974.
96. **Meschia M, Pansini F, Modena AB, de Aloysio D, Gambacciani M, Parazzini F, Campagnoli C, Maiocchi G, Peruzzi E**; On behalf of the **ICARUS Study Group**, Determinants of age at menopause in Italy: results from a large cross-sectional study. ICARUS Study Group. Italian Climacteric Research Group Study, *Maturitas* 34:119, 2000.
97. **Gold EB, Bromberger J, Crawford S, Samuels S, Greendale GA, Harlow SD, Skurnick J**, Factors associated with age at natural menopause in a multiethnic sample of midlife women, *Am J Epidemiol* 153:865, 2001.
98. **de Vries E, den Tonkelaar I, van Noord PAH, van der Schouw YT, te Velde ER, Peeters PHM**, Oral contraceptive use in relation to age at menopause in the DOM cohort, *Hum Reprod* 16:1657, 2001.
99. **Coulam CB, Adamsen SC, Annegers JF**, Incidence of premature ovarian failure, *Obstet Gynecol* 67:604, 1986.
100. **Luborsky JL, Meyer P, Sowers MF, Gold EB, Santoro N**, Premature menopause in a multi-ethnic population study of the menopause transition, *Hum Reprod* 18:199, 2003.
101. **Dratva J, Real FG, Schindler C, Ackermann-Liebrich U, Gerbase MW, Probst-Hensch NM, Svanes C, Omenaas ER, Neukirch F, Wjst M, Morabia A, Jarvis D, Leynaert B, Zemp E**, Is age at menopause increasing across Europe? Results on age at menopause and determinants from two population-based studies, *Menopause* 16:385, 2009.
102. **Kapur P, Sinha B, Pereira BMJ**, Measuring climacteric symptoms and age at natural menopause in an Indian population using the Greene Climacteric Scale, *Menopause* 16:378, 2009.
103. **Tibiletti MG, Testa G, Vegetti W, Alagna F, Taborelli M, Dalpra L, Bolis PF, Crosignani PG**, The idiopathic forms of premature menopause and early menopause show the same genetic pattern, *Hum Reprod* 14:2731, 1999.
104. **Vegetti W, Marozzi A, Manfredini E, Testa G, Alagna F, Nicolosi A, Caliari I, Taborelli M, Tibiletti MG, Dalpra L, Crosignani PG**, Premature ovarian failure, *Mol Cell Endocrinol* 161:53, 2000.
105. **Torgerson DJ, Avenell A, Russell IT, Reid DM**, Factors associated with onset of menopause in women aged 45–49, *Maturitas* 19:83, 1994.
106. **Torgerson DJ, Thomas RE, Campbell MK, Reid DM**, Alcohol consumption and age of maternal menopause are associated with menopause onset, *Maturitas* 26:21, 1997.
107. **Cramer DW, Xu H, Harlow BL**, Family history as a predictor of early menopause, *Fertil Steril* 64:740, 1995.
108. **Nelson LM**, Clinical practice. Primary ovarian insufficiency, *N Engl J Med* 360(6):606, 2009.
109. **Baird DD, Tylavsky FA, Anderson JJB**, Do vegetarians have earlier menopause? Proceedings of the Society of Epidemiologic Research, *Am J Epidemiol* 19:1, 1988.
110. **MacMahon B, Worcester J**, Age at menopause U.S. 1960–62, *Vital Health Stat* 19:1, 1966.
111. **Katsouyanni K, Boyle P, Trichopoulos D**, Diet and urine estrogens among postmenopausal women, *Oncology* 48:490, 1991.
112. **Gapstur SM, Potter JD, Sellers TA, Folsom AR**, Increased risk of breast cancer with alcohol consumption in postmenopausal women, *Am J Epidemiol* 136:1221, 1992.
113. **Gavaler JS, Van Thiel DH**, The association between moderate alcoholic beverage consumption and serum estradiol and testosterone levels in normal postmenopausal women: relationship to the literature, *Alcohol Clin*

Exp Res 16:87, 1992.

114. **Holbrook TC, Barrett-Connor E**, A prospective study of alcohol consumption and bone mineral density, *Br Med J* 306:1506, 1993.
115. **Ginsburg EL, Mello NK, Mendelson JH, Barbieri RL, Teoh SK, Rothman M, Gao X, Sholar JW**, Effects of alcohol ingestion on estrogens in postmenopausal women, *JAMA* 276:1747, 1996.
116. **Snieder H, MacGregor AJ, Spector TD**, Genes control the cessation of a woman's reproductive life: a twin study of hysterectomy and age at menopause, *J Clin Endocrinol Metab* 83:1875, 1998.
117. **Rödström K, Bengtsson C, Milsom I, Lissner L, Sundh V, Björkelund C**, Evidence for a secular trend in menopausal age: a population study of women in Gothenburg, *Menopause* 10:538, 2003.
118. **Brambila DJ, McKinlay SM, Johannes CB**, Defining the perimenopause for application in epidemiologic investigations, *Am J Epidemiol* 140:1091, 1994.
119. **Bromberger JT, Matthews KA, Kuller LH, Wing RR, Meilahn EN, Plantinga P**, Prospective study of the determinants of age at menopause, *Am J Epidemiol* 145:124, 1997.
120. **Cassou B, Derriennic F, Monfort C, Dell'Accio P, Touranchet A**, Risk factors of early menopause in two generations of gainfully employed French women, *Maturitas* 26:165, 1997.
121. **Beall CM**, Ages at menopause and menarche in a high-altitude Himalayan population, *Ann Hum Biol* 10:365, 1983.
122. **Gonzales GF, Villena A**, Age at menopause in Central Andean Peruvian women, *Menopause* 4:32, 1997.
123. **Leidy LF**, Early age at menopause among left-handed women, *Obstet Gynecol* 76:1111, 1990.
124. **Dane S, Reis N, Pasinliogu T**, Left-handed women have earlier age of menopause, *J Basic Clin Physiol Pharmacol* 10:147, 1999.
125. **Cresswell JL, Egger P, Fall CHD, Osmond C, Fraser RB, Barker DJP**, Is the age of menopause determined in-utero?, *Early Hum Dev* 49:143, 1997.
126. **Siddle N, Sarrel P, Whitehead M**, The effect of hysterectomy on the age at ovarian failure: identification of a subgroup of women with premature loss of ovarian function and literature review, *Fertil Steril* 47:94, 1987.
127. **Derksen JGM, Brömann HAM, Wiegerinck MAHM, Vader HL, Heintz APM**, The effect of hysterectomy and endometrial ablation on follicle stimulating hormone (FSH) levels up to 1 year after surgery, *Maturitas* 29:133, 1998.
128. **Chalmers C, Lindsay M, Usher D, Warner P, Evans D, Ferguson M**, Hysterectomy and ovarian function: levels of follicle stimulating hormone and incidence of menopausal symptoms are not affected by hysterectomy in women under age 45 years, *Climacteric* 5:366, 2002.
129. **Rustamov O, Krishnan M, Roberts SA, Fitzgerald CT**, Effect of salpingectomy, ovarian cystectomy and unilateral salpingo-oophorectomy on ovarian reserve, *Gynecol Surg* 13:173, 2016.
130. **Willett W, Stampfer MJ, Bain C, Lipnick R, Speizer FE, Rosner B, Cramer D, Hennekens CH**, Cigarette smoking, relative weight, and menopause, *Am J Epidemiol* 117:651, 1983.
131. **Midgette AS, Baron JA**, Cigarette smoking and the risk of natural menopause, *Epidemiology* 1:474, 1990.
132. **Amundsen DW, Diers CJ**, The age of menopause in classical Greece and Rome, *Hum Biol* 42:79, 1970.
133. **Amundsen DW, Diers CJ**, The age of menopause in medieval Europe, *Hum Biol* 45:605, 1973.
134. **Frommer DJ**, Changing age at menopause, *Br Med J* 2:349, 1964.
135. **Traupman J, Eckels E, Hatfield E**, Intimacy in older women's lives, *Gerontologist* 2:493, 1982.
136. **Pfeiffer E, Verwoerd A, Davis GC**, Sexual behavior in middle life, *Am J Psychiatr* 128:1262, 1972.
137. **Greendale GA, Hogan P, Shumaker S; for the Postmenopausal Estrogen/Progestin Interventions Trial (PEPI) Investigators**, Sexual functioning in postmenopausal women: the Postmenopausal Estrogen/Progestin Interventions (PEPI) trial, *J Womens Health* 5:445, 1996.
138. **Lindau ST, Schumm LP, Waumann EO, Levinson W, O'Muircheartaigh CA, Waite LJ**, A study of sexuality and health among older adults in the United States, *N Engl J Med* 357:762, 2007.
139. **Shifren JL, Monz BU, Russo PA, Segreti A, Johannes CB**, Sexual problems and distress in United States women. Prevalence and correlates, *Obstet Gynecol* 112:970, 2008.
140. **Taylor HS, Tal A, Pal L, Li F, Black DM, Brinton EA, Budoff MJ, Cedars MI, Du W, Hodis HN, Lobo RA, Manson JE, Merriam GR, Miller VM, Naftolin F, Neal-Perry G, Santoro NF, Harman SM**,

Effects of oral vs transdermal estrogen therapy on sexual function in early postmenopause: ancillary study of the Kronos Early Estrogen Prevention Study (KEEPS), *JAMA Intern Med* 177(10):1471, 2017.

141. **Dennerstein L, Lehert P, Burger H**, The relative effects of hormones and relationship factors on sexual function of women through the natural menopause transition, *Fertil Steril* 84:174, 2005.
142. **Rhodes JC, Kjerulff KH, Langenberg PW, Guzinski GM**, Hysterectomy and sexual function, *JAMA* 282:20, 1999.
143. **Anderson HD, Pace WD, Libby AM, West DR, Valuck RJ**, Rates of 5 common antidepressant side effects among new adult and adolescent cases of depression: a retrospective US claims study, *Clin Ther* 34(1):113, 2012.
144. **DeLamater J, Karraker A**, Sexual functioning in older adults, *Curr Psychiatry Rep* 11:6, 2009.
145. **Martin CE**, Factors affecting sexual functioning in 60–79 year-old married males, *Arch Sex Behav* 10:399, 1981.
146. **George LK, Weiler SJ**, Sexuality in middle and late life, *Arch Gen Psychiatr* 38:919, 1981.
147. **White CB**, Sexual interest, attitudes, knowledge, and sexual history in relation to sexual behavior in the institutionalized aged, *Arch Sex Behav* 11:11, 1982.
148. **Renshaw DC**, Sex, intimacy, and the older woman, *Women Health* 8:43, 1983.
149. **Dennerstein L, Lehert P, Burger H, Dudley E**, Factors affecting sexual functioning of women in the midlife years, *Climacteric* 2:254, 1999.
150. **Dennerstein L, Dudley E, Burger H**, Are changes in sexual functioning during midlife due to aging or menopause?, *Fertil Steril* 76:456, 2001.
151. **Gosden RG**, Follicular status at menopause, *Hum Reprod* 2:617, 1987.
152. **Chakravarti S, Collins WP, Forecast JD, Newton JR, Oram DH, Studd JWW**, Hormonal profiles after the menopause, *Br Med J* 2:784, 1976.
153. **Jiroutek MR, Chen M-H, Johnston CC, Longcope C**, Changes in reproductive hormones and sex hormone-binding globulin in a group of postmenopausal women measured over 10 years, *Menopause* 5:90, 1998.
154. **Meldrum DR, Davidson BJ, Tataryn IV, Judd HL**, Changes in circulating steroids with aging in postmenopausal women, *Obstet Gynecol* 57:624, 1981.
155. **Grodin JM, Siiteri PK, McDonald PC**, Source of estrogen production in postmenopausal women, *J Clin Endocrinol Metab* 36:207, 1963.
156. **Parker CR Jr, Slayden SM, Azziz R, Crabbe SL, Hines GA, Boots LR, Bae S**, Effects of aging on adrenal function in the human: responsiveness and sensitivity of adrenal androgens and cortisol to adrenocorticotropin in premenopausal and postmenopausal women, *J Clin Endocrinol Metab* 85:48, 2000.
157. **Labrie F, Bélanger A, Cusan L, Gomez J-L, Candas B**, Marked decline in serum concentrations of adrenal C19 sex steroid precursors and conjugated androgen metabolites during aging, *J Clin Endocrinol Metab* 82:2396, 1997.
158. **Burger HG, Dudley EC, Cui J, Dennerstein L, Hopper JL**, A prospective longitudinal study of serum testosterone, dehydroepiandrosterone sulfate, and sex hormone-binding globulin levels through the menopause transition, *J Clin Endocrinol Metab* 85:2832, 2000.
159. **Jabara S, Christenson LK, Wang CY, McAllister JM, Javitt NB, Dunaif A, Strauss JF III**, Stromal cells of the human postmenopausal ovary display a distinctive biochemical and molecular phenotype, *J Clin Endocrinol Metab* 88:484, 2003.
160. **Dowsett M, Cantwell B, Anshumala L, Jeffcoate SL, Harris SL**, Suppression of postmenopausal ovarian steroidogenesis with the luteinizing hormone-releasing hormone agonist goserelin, *J Clin Endocrinol Metab* 66:672, 1988.
161. **Andreyko JL, Monroe SE, Marshall LA, Fluker MR, Nerenberg CA, Jaffe RB**, Concordant suppression of serum immunoreactive luteinizing hormone (LH), follicle-stimulating hormone, subunit, bioactive LH, and testosterone in postmenopausal women by a potent gonadotropin releasing hormone antagonist (detirelix), *J Clin Endocrinol Metab* 74:399, 1992.
162. **Sluijmer AV, Heineman MJ, De Jong FH, Evers JL**, Endocrine activity of the postmenopausal ovary: the

- effects of pituitary down-regulation and oophorectomy, *J Clin Endocrinol Metab* 80:2163, 1995.
163. **Longcope C, Franz C, Morello C, Baker RS, Johnston CC Jr**, Steroid and gonadotropin levels in women during the peri-menopausal years, *Maturitas* 8:189, 1986.
  164. **Laughlin GA, Barrett-Conner E, Kritz-Silverstin D, von Mühlen D**, Hysterectomy, oophorectomy, and endogenous sex hormone levels in older women: the Rancho Bernardo Study, *J Clin Endocrinol Metab* 85:645, 2000.
  165. **Couzinet B, Meduri G, Lecce MG, Young J, Brailly S, Loosfelt H, Milgrom E, Schaison G**, The postmenopausal ovary is not a major androgen-producing gland, *J Clin Endocrinol Metab* 86:5060, 2001.
  166. **Judd HL, Judd GE, Lucas WE, Yen SSC**, Endocrine function of the postmenopausal ovary; concentration of androgens and estrogens in ovarian and peripheral vein blood, *J Clin Endocrinol Metab* 39:1020, 1974.
  167. **Judd HL, Shamonki IM, Frumar AM, Lagasse LD**, Origin of serum estradiol in postmenopausal women, *Obstet Gynecol* 59:680, 1982.
  168. **Longcope C, Jaffe W, Griffing G**, Production rates of androgens and oestrogens in post-menopausal women, *Maturitas* 3:215, 1981.
  169. **Adashi EY**, The climacteric ovary as a functional gonadotropin-driven androgen-producing gland, *Fertil Steril* 62:20, 1994.
  170. **Beyene Y**, *From Menarche to Menopause: Reproductive Lives of Peasant Women in Two Cultures*, State University of New York Press, Albany, 1989.
  171. **Lock M**, *Encounters with Aging: Mythologies of Menopause in Japan and North America*, University of California Press, Berkeley, 1993.
  172. **Lock M**, Menopause in cultural context, *Exp Gerontol* 29:307, 1994.
  173. **Moore B, Kombe H**, Climacteric symptoms in a Tanzanian community, *Maturitas* 13:229, 1991.
  174. **Martin MC, Block JE, Sanchez SD, Arnaud CD, Beyene Y**, Menopause without symptoms: the endocrinology of menopause among rural Mayan Indians, *Am J Obstet Gynecol* 168:1839, 1993.
  175. **Robinson G**, Cross-cultural perspectives on menopause, *J Nerv Ment Dis* 184:453, 1996.
  176. **Richters JMA**, Menopause in different cultures, *J Psychosom Obstet Gynecol* 18:73, 1997.
  177. **Gold EB, Sternfeld B, Kelsey JL, Brown C, Mouton C, Reame N, Salamone L, Stellato R**, Relation of demographic and lifestyle factors to symptoms in a multi-racial/ethnic population of women 40–55 years of age, *Am J Epidemiol* 152:463, 2000.
  178. **Obermeyer CM**, Menopause across cultures: a review of the evidence, *Menopause* 7:184, 2000.
  179. **Randolph JF Jr, Sowers M, Gold EB, Morh BA, Luborsky J, Santoro N, McConnell DS, Finkelstein JS, Kornenman SG, Matthews KA, Sternfeld B, Lasley BL**, Reproductive hormones in the early menopausal transition: relationship to ethnicity, body size, and menopausal status, *J Clin Endocrinol Metab* 88:1516, 2003.
  180. **Van Voorhis BJ, Santoro N, Harlow S, Crawford SL, Randolph J**, The relationship of bleeding patterns to daily reproductive hormones in women approaching menopause, *Obstet Gynecol* 112:101, 2008.
  181. **Goldstein SR, Zeltser I, Horan CK, Snyder JR, Schwartz LB**, Ultrasonography-based triage for perimenopausal patients with abnormal uterine bleeding, *Am J Obstet Gynecol* 177:102, 1997.
  182. **Smith-Bindman R, Kerlikowske K, Feldstein VA, Subak L, Scheidler J, Segal M, Brand R, Grady D**, Endovaginal ultrasound to exclude endometrial cancer and other endometrial abnormalities, *JAMA* 280:1510, 1998.
  183. **Gull B, Karlsson B, Milsom I, Granberg S**, Can ultrasound replace dilation and curettage? A longitudinal evaluation of postmenopausal bleeding and transvaginal sonographic measurement of the endometrium as predictors of endometrial cancer, *Am J Obstet Gynecol* 188:401, 2003.
  184. **Gupta JK, Chien PF, Voit D, Clark TJ, Khan KS**, Ultrasonographic endometrial thickness for diagnosing endometrial pathology in women with postmenopausal bleeding: a meta-analysis, *Acta Obstet Gynecol Scand* 81:799, 2002.
  185. Practice Bulletin No. 136: management of abnormal uterine bleeding associated with ovulatory dysfunction, *Obstet Gynecol* 122(1):176, 2013.
  186. Practice Bulletin No. 128: diagnosis of abnormal uterine bleeding in reproductive-aged women, *Obstet Gynecol*

120(1):197, 2012.

187. **Einerth Y**, Vacuum curettage by the Vabra method. A simple procedure for endometrial diagnosis, *Acta Obstet Gynecol Scand* 61:373, 1982.
188. **Feldman S, Shapter A, Welch WR, Berkowitz RS**, Two-year follow-up of 263 patients with post/perimenopausal vaginal bleeding and negative initial biopsy, *Gynecol Oncol* 55:56, 1994.
189. **Lin HH, Wu MY, Shyu MK, Chen D, Tsai JL, Hsieh CY**, Clinical study of 381 postmenopausal bleeding patients, *J Formos Med Assoc* 92:241, 1993.
190. Practice Bulletin No. 168: cervical cancer screening and prevention, *Obstet Gynecol* 128(4):e111, 2016.
191. **Royal College of Obstetricians and Gynaecologists (RCOG) with the British Society for Gynaecological Endoscopy (BSGE)**, Management of Endometrial Hyperplasia. Green-top Guideline Royal College of Obstetricians and Gynaecologists (RCOG) with the British Society for Gynaecological Endoscopy (BSGE). Management of Endometrial Hyperplasia. Green-top Guideline Royal College of Obstetricians and Gynaecologists (RCOG) with the British Society for Gynaecological Endoscopy (BSGE). Management of Endometrial Hyperplasia. Green-top Guideline No. 67, RCOG/BSGE Joint Guideline, London, 2016.
192. **Reed SD, Voigt LF, Newton KM, Garcia RH, Allison K, Epplein M, Jordan D, Swisher E, Weiss NS**, Progestin therapy of complex endometrial hyperplasia with and without atypia, *Obstet Gynecol* 113:655, 2009.
193. **Gebbie AE, Glasier A, Sweeting V**, Incidence of ovulation in perimenopausal women before and during hormone replacement therapy, *Contraception* 52:221, 1995.
194. **Casper RF, Dodin S, Reid RL; Study Investigators**, The effect of 20 µg ethinyl estradiol/1 mg norethindrone acetate (Minestrin), a low-dose oral contraceptive, on vaginal bleeding patterns, hot flashes, and quality of life in symptomatic perimenopausal women, *Menopause* 4:139, 1997.
195. **Castracane VD, Gimpel T, Goldzieher JW**, When is it safe to switch from oral contraceptives to hormonal replacement therapy?, *Contraception* 52:371, 1995.
196. **Creinin MD**, Laboratory criteria for menopause in women using oral contraceptives, *Fertil Steril* 66:101, 1996.
197. **Crosignani PG, Vercellini P, Mosconi P, Oldani S, Cortesi I, De Giorgi O**, Levonorgestrel-releasing intrauterine device versus hysteroscopic endometrial resection in the treatment of dysfunctional uterine bleeding, *Obstet Gynecol* 90:257, 1997.
198. **Kaunitz AM, Meredith S, Inki P, Kubba A, Sanchez-Ramos L**, Levonorgestrel-releasing intrauterine system and endometrial ablation in heavy menstrual bleeding. A systematic review and meta-analysis, *Obstet Gynecol* 113:1104, 2009.
199. **Irvine GA, Campbell-Brown MB, Lumsden MA, Heikkila A, Walker JJ, Cameron IT**, Randomised comparative trial of the levonorgestrel intrauterine system and norethisterone for treatment of idiopathic menorrhagia, *Br J Obstet Gynaecol* 105:592, 1998.
200. **Istre O, Trolle B**, Treatment of menorrhagia with the levonorgestrel intrauterine system versus endometrial resection, *Fertil Steril* 76:304, 2001.
201. **Romer T**, Prospective comparison study of levonorgestrel IUD versus Roller-Ball endometrial ablation in the management of refractory recurrent hypermenorrhea, *Eur J Obstet Gynecol Reprod Biol* 90:27, 2000.
202. **Bahamondes L, Ribeiro-Huguet P, de Andrade KC, Leon-Martins O, Petta CA**, Levonorgestrel-releasing intrauterine system (Mirena) as a therapy for endometrial hyperplasia and carcinoma, *Acta Obstet Gynecol Scand* 82:580, 2003.
203. **Vereide AB, Kaino T, Sager G, Arnes M, Ørbo A**, Effect of levonorgestrel IUD and oral medroxyprogesterone acetate on glandular and stromal progesterone receptors (PRA and PRB), and estrogen receptors (ER-alpha and ER-beta) in human endometrial hyperplasia, *Gynecol Oncol* 101:214, 2006.
204. **Wildemeersch D, Pylser K, De Wever N, Dhont M**, Treatment of non atypical and atypical endometrial hyperplasia with a levonorgestrel-releasing intrauterine system: long-term follow-up, *Maturitas* 57:210, 2007.
205. **Wheeler DT, Bristow RE, Kurman RJ**, Histologic alterations in endometrial hyperplasia and well-differentiated carcinoma treated with progestins, *Am J Surg Pathol* 31:988, 2007.
206. **Varma R, Soneja H, Bhatia K, Ganesan R, Rollason T, Clark TJ, Gupta JK**, The effectiveness of a levonorgestrel-releasing intrauterine system (LNG-IUS) in the treatment of endometrial hyperplasia—a long-term follow-up study, *Eur J Obstet Gynecol Reprod Biol* 139:169, 2008.

207. **Haimovich S, Checa MA, Mancebo G, Fusté P, Carreras R**, Treatment of endometrial hyperplasia without atypia in peri- and postmenopausal women with a levonorgestrel intrauterine device, *Menopause* 15:1002, 2008.
208. **Ørbo A, Arnes M, Hancke C, Vereide AB, Pettersen I, Larsen K**, Treatment results of endometrial hyperplasia after prospective D-score classification: a follow-up study comparing effect of LNG-IUD and oral progestins versus observation only, *Gynecol Oncol* 111:68, 2008.
209. **Vereide AB, Arnes M, Straume B, Maltau JM, Ørbo A**, Nuclear morphometric changes and therapy monitoring in patients with endometrial hyperplasia: a study comparing effects of intrauterine levonorgestrel and systemic medroxyprogesterone, *Gynecol Oncol* 91:526, 2003.
210. **Gallos ID, Krishan P, Shehmar M, Ganesan R, Gupta JK**, LNG-IUS versus oral progestogen treatment for endometrial hyperplasia: a long-term comparative cohort study, *Hum Reprod* 28(11):2966, 2013.
211. **Inki P, Hurskainen R, Palo P, Ekholm E, Grenman S, Kivela A, Kujansuu E, Teperi J, Yliskoski M, Paavonen J**, Comparison of ovarian cyst formation in women using the levonorgestrel-releasing intrauterine system vs. hysterectomy, *Ultrasound Obstet Gynecol* 20:381, 2002.
212. **Kroon E, Andolf E**, Diagnosis and follow-up of simple ovarian cysts detected by ultrasound in postmenopausal women, *Obstet Gynecol* 85:211, 1995.
213. **Nardo LG, Kroon ND, Reginald PW**, Persistent unilocular ovarian cysts in a general population of postmenopausal women: is there a place for expectant management?, *Obstet Gynecol* 102:589, 2003.
214. **Kronenberg F, Barnard RM**, Modulation of menopausal hot flashes by ambient temperature, *J Therm Biol* 17:43, 1992.
215. **Hunter M**, The South-East England longitudinal study of the climacteric and postmenopause, *Maturitas* 14:17, 1992.
216. **Oldenhave A, Jaszmann LJB, Haspels AA, Everaerd WTAM**, Impact of climacteric on well-being, *Am J Obstet Gynecol* 168:772, 1993.
217. **Hahn PM, Wong J, Reid RL**, Menopausal-like hot flashes reported in women of reproductive age, *Fertil Steril* 70:913, 1998.
218. **Guthrie JR, Dennerstein L, Hopper JL, Burger HG**, Hot flashes, menstrual status, and hormone levels in a population-based sample of midlife women, *Obstet Gynecol* 88:437, 1996.
219. **Williams RE, Kalilani L, DiBenedetti DB, Zhou X, Granger AL, Fehnel SE, Levine KB, Jordan J, Clark RV**, Frequency and severity of vasomotor symptoms among peri- and postmenopausal women in the United States, *Climacteric* 11:32, 2008.
220. **Rödström K, Bengtsson C, Lissner L, Milsom I, Sundh V, Bjorkelund C**, A longitudinal study of the treatment of hot flashes: the population study of women in Gothenburg during a quarter of a century, *Menopause* 9:156, 2002.
221. **Avis NE, Stellato R, Crawford S, Bromberger J, Ganz P, Cain V, Kagawa-Singer M**, Is there a menopausal syndrome? Menopausal status and symptoms across racial/ethnic groups, *Soc Sci Med* 52:345, 2001.
222. **Schwingl PJ, Hulka BS, Harlow SD**, Risk factors for menopausal hot flashes, *Obstet Gynecol* 84:29, 1994.
223. **Pham KT, Grisso JA, Freeman EW**, Ovarian aging and hormone replacement therapy. Hormonal levels, symptoms, and attitudes of African-American and white women, *J Gen Intern Med* 12:230, 1997.
224. **Thurston RC, Sowers MR, Chang Y, Sternfeld B, Gold EB, Johnston JM, Matthews KA**, Adiposity and reporting of vasomotor symptoms among midlife women: the Study of Women's Health Across the Nation, *Am J Epidemiol* 167:78, 2008.
225. **Kronenberg F**, Hot flashes: epidemiology and physiology, *Ann N Y Acad Sci* 592:52, 1990.
226. **Freeman EW, Sherif K**, Prevalence of hot flashes and night sweats around the world: a systematic review, *Climacteric* 10:197, 2007.
227. **Brown DE, Sievert LL, Morrison LA, Reza AM, Mills PS**, Do Japanese American women really have fewer hot flashes than European Americans? The Hilo Women's Health Study, *Menopause* 16:870, 2009.
228. **Politi MC, Schleinitz MD, Col NF**, Revisiting the duration of vasomotor symptoms of menopause: a meta-analysis, *J Gen Intern Med* 23:1507, 2008.



229. **Col NF, Guthrie JR, Politi M, Dennerstein L**, Duration of vasomotor symptoms in middle-aged women: a longitudinal study, *Menopause* 16:453, 2009.
230. **Avis NE, Crawford SL, Greendale G, Bromberger JT, Everson-Rose SA, Gold EB, Hess R, Joffe H, Kravitz HM, Tepper PG, Thurston RC; Study of Women's Health Across the Nation**, Duration of menopausal vasomotor symptoms over the menopause transition, *JAMA Intern Med* 175(4):531, 2015.
231. **Freedman RR**, Hot flashes: behavioral treatments, mechanisms, and relation to sleep, *Am J Med* 118(Suppl 12B):124, 2005. Figure A.
232. **Freedman RR, Benton MD, Genik RJ II, Graydon FX**, Cortical activation during menopausal hot flashes, *Fertil Steril* 85:674, 2006.
233. **Wilkin JR**, Flushing reactions: consequences and mechanisms, *Ann Intern Med* 95:468, 1981.
234. **Aksel S, Schomberg DW, Tyrey L, Hammond CB**, Vasomotor symptoms, serum estrogens and gonadotropin levels in surgical menopause, *Am J Obstet Gynecol* 126:165, 1976.
235. **Freedman RR**, Physiology of hot flashes, *Am J Hum Biol* 13:453, 2001.
236. **Freedman RR**, Biochemical, metabolic, and vascular mechanisms in menopausal hot flashes, *Fertil Steril* 70:332, 1998.
237. **Mohyi D, Tabassi K, Simon J**, Differential diagnosis of hot flashes, *Maturitas* 27:203, 1997.
238. **MacLennan AH, Henry D, Hills S, Moore V**, Oral oestrogen replacement therapy versus placebo for hot flushes, *Menstrual Disorders Module of the Cochrane Database of Systematic Reviews*, 2000.
239. **Pearce J, Hawton K, Blake F, Barlow D, Rees M, Fagg J, Keenan J**, Psychological effects of continuation versus discontinuation of hormone replacement therapy by estrogen implants: a placebo-controlled study, *J Psychosom Res* 42:177, 1997.
240. **Raz R, Stamm WE**, A controlled trial of intravaginal estriol in postmenopausal women with recurrent urinary tract infection, *N Engl J Med* 329:753, 1993.
241. **Caillouette JC, Sharp CF, Zimmerman GJ, Roy S**, Vaginal pH as a marker for bacterial pathogens and menopausal status, *Am J Obstet Gynecol* 176:1270, 1997.
242. **Roy S, Caillouette JC, Roy T, Faden JS**, Vaginal pH is similar to FSH for menopause diagnosis, *Am J Obstet Gynecol* 190:1272, 2004.
243. **Semmens JP, Wagner G**, Effects of estrogen therapy on vaginal physiology during menopause, *Obstet Gynecol* 66:15, 1985.
244. **Wilson PD, Faragher B, Butler B, Bullock D, Robinson EL, Brown ADG**, Treatment with oral piperazine oestrone sulphate for genuine stress incontinence in postmenopausal women, *Br J Obstet Gynaecol* 94:568, 1987.
245. **Bhatia NN, Bergman A, Karram MM**, Effects of estrogen on urethral function in women with urinary incontinence, *Obstet Gynecol* 160:176, 1989.
246. **Goes VR, Sartori MG, Baracat EC, Rodrigues de Lima G, Girao MJ**, Urodynamic and clinical evaluation of postmenopausal women with stress urinary incontinence before and after cyclic estrogen therapy, *Clin Exp Obstet Gynecol* 30:103, 2003.
247. **Al-Badr A, Ross S, Soroka D, Drutz HP**, What is the available evidence for hormone replacement therapy in women with stress urinary incontinence?, *J Obstet Gynaecol Can* 25:567, 2003.
248. **Fantl JA, Bump RC, Robinson D, McLish DK, Wyman JF**, Efficacy of estrogen supplementation in the treatment of urinary incontinence, *Obstet Gynecol* 88:745, 1996.
249. **Jackson S, Shepherd A, Brookes S, Abrams P**, The effect of oestrogen supplementation on postmenopausal urinary stress incontinence: a double-blind placebo-controlled trial, *Br J Obstet Gynaecol* 106:711, 1999.
250. **Steinauer JE, Waetjen LE, Vittinghoff E, Subak LL, Hulley SB, Grady D, Lin F, Brown JS; for the Heart and Estrogen/Progestin Replacement Study Research Group**, Postmenopausal hormone therapy. Does it cause incontinence?, *Obstet Gynecol* 106:940, 2005.
251. **Townsend MK, GCurhan GC, Resnick NM, Grodstein F**, Postmenopausal hormone therapy and incident urinary incontinence in middle-aged women, *Am J Obstet Gynecol* 200:86.e1, 2009.
252. **Waetjen LE, Feng W-Y, Ye J, Johnson WO, Greendale GA, Sampsel CM, Sternfield B, Harlow SD,**

- Gold EB**; for the **Study of Women's Health Across the Nation (SWAN)**, Factors associated with worsening and improving urinary incontinence across the menopausal transition, *Obstet Gynecol* 111:667, 2008.
253. **Waetjen LE, Ye J, Feng W-Y, Johnson WO, Greendale GA, Sampsel CM, Sternfield B, Harlow S, Gold EB**; for the **Study of Women's Health Across the Nation (SWAN)**, Association between menopausal transition stages and developing urinary incontinence, *Obstet Gynecol* 114:989, 2009.
254. **Cody JD, Jacobs ML, Richardson K, Moehrer B, Hextall A**, Oestrogen therapy for urinary incontinence in post-menopausal women, *Cochrane Database Syst Rev* 10:CD001405, 2012.
255. **Tzur T, Yohai D, Weintraub AY**, The role of local estrogen therapy in the management of pelvic floor disorders, *Climacteric* 19(2):162, 2016.
256. **Castelo-Branco C, Duran M, Gonzalez-Merlo J**, Skin collagen changes related to age and hormone replacement therapy, *Maturitas* 15:113, 1992.
257. **Savvas M, Lausrent GB**, Type III collagen content in the skin of postmenopausal women receiving oestradiol and testosterone implants, *Br J Obstet Gynaecol* 100:154, 1993.
258. **Maheux R, Naud F, Rioux M, Grenier R, Lemay A, Guy J, Langevin M**, A randomized, double-blind, placebo-controlled study on the effect of conjugated estrogens on skin thickness, *Am J Obstet Gynecol* 170:642, 1994.
259. **Callens A, Vaillant L, Lecomte P, Berson M, Gall Y, Lorette G**, Does hormonal skin aging exist? A study of the influence of different hormone therapy regimens on the skin of postmenopausal women using non-invasive measurement techniques, *Dermatology* 193:289, 1996.
260. **Sator P-G, Schmidt JB, Sator MO, Huber JC, Hönigsmann H**, The influence of hormone replacement therapy on skin ageing. A pilot study, *Maturitas* 39:43, 2001.
261. **Holland EFN, Studd JWW, Mansell JP, Leather AT, Bailey AJ**, Changes in collagen composition and cross-links in bone and skin of osteoporotic postmenopausal women treated with percutaneous estradiol implants, *Obstet Gynecol* 83:180, 1994.
262. **Castelo-Branco C, Pons F, Gratacòs E, Fortuny A, Vanrell JA, Gonzalez-Merlo J**, Relationship between skin collagen and bone changes during aging, *Maturitas* 18:199, 1994.
263. **Creidi P, Faivre B, Agache P, Richard E, Haudiquet V, Sauvanet JP**, Effect of a conjugated oestrogen (Premarin) cream on aging facial skin. A comparative study with a placebo cream, *Maturitas* 19:211, 1994.
264. **Sator PG, Sator MO, Schmidt JB, Nahavandi H, Radakovic S, Huber JC, Hönigsmann H**, A prospective, randomized, double-blind, placebo-controlled study on the influence of hormone replacement therapy on skin aging in postmenopausal women, *Climacteric* 10:320, 2007.
265. **Dunn LB, Damesyn M, Moore AA, Reuben DB, Greendale GA**, Does estrogen prevent skin aging? Results from the First National Health and Nutrition Examination Survey (NHANES I), *Arch Dermatol* 133:339, 1997.
266. **Castelo-Branco C, Figueras F, Martínez de Osaba MJ, Vanrell JA**, Facial wrinkling in postmenopausal women. Effects of smoking status and hormone replacement therapy, *Maturitas* 29:75, 1998.
267. **Phillips TJ, Symons J, Menon S; HT Study Group**, Does hormone therapy improve age-related skin changes in postmenopausal women? A randomized, double-blind, double-dummy, placebo-controlled multicenter study assessing the effects of norethindrone acetate and ethinyl estradiol in the improvement of mild to moderate age-related skin changes in postmenopausal women, *J Am Acad Dermatol* 59:397, 2008.
268. **Cauley JA, Petrini AM, LaPorte RE, Sandler RB, Bayles CM, Robertson RJ, Slemenda CW**, The decline of grip strength in the menopause: relationship to physical activity, estrogen use and anthropometric factors, *J Chronic Dis* 40:115, 1987.
269. **Phillips SK, Rook KM, Siddle NC, Bruce SA, Woldege RC**, Muscle weakness in women occurs at an earlier age than in men but strength is preserved by hormone replacement therapy, *Clin Sci (Lond)* 84:95, 1993.
270. **Preisinger E, Alacamlioglu Y, Saradeth T, Resch KL, Holzer G, Metka M**, Forearm bone density and grip strength in women after menopause with and without estrogen replacement therapy, *Maturitas* 21:57, 1995.
271. **Hammar ML, Lindgren R, Berg GE, Möller CG, Niklasson MK**, Effects of hormonal replacement therapy on postural balance among postmenopausal women, *Obstet Gynecol* 88:955, 1996.

272. **Naessen T, Lindmark B, Larsen H-C**, Better postural balance in elderly women receiving estrogens, *Am J Obstet Gynecol* 177:412, 1997.
273. **Ronkainen PHA, Kovanen V, Alen M, Pöllänen E, Palonen EM, Ankarberg-Lindgren C, Hämäläinen E, Turpeinen U, Kujala UM, Puolakka J, Kaprio J, Sipilä S**, Postmenopausal hormone replacement therapy modifies skeletal muscle composition and function: a study with monozygotic twin pairs, *J Appl Physiol* 107:25, 2009.
274. **Ballinger CB**, Psychiatric aspects of the menopause, *Br J Psychiatr* 156:773, 1990.
275. **Schmidt PJ, Rubinow DR**, Menopause-related affective disorders: a justification for further study, *Am J Psychiatr* 148:844, 1991.
276. **Gath D, Osborn M, Bungay G, Iles S, Day A, Bond A, Passingham C**, Psychiatric disorder and gynaecological symptoms in middle aged women: a community survey, *Br Med J* 294:213, 1987.
277. **Everson SA, Matthews KA, Guzick DS, Meilahn EN, Wing RR, Kuller LH**, Effects of surgical menopause on lipid levels and psychosocial characteristics: the Healthy Women Study, *Health Psychol* 14:435, 1995.
278. **Avis NE, Brambilla D, McKinlay SM, Vass K**, A longitudinal analysis of the association between menopause and depression. Results from the Massachusetts Women's Health Study, *Ann Epidemiol* 4:214, 1994.
279. **Kessler RC, McGonagle KA, Swartz M, Blazer DG, Nelson CB**, Sex and depression in the National Comorbidity Survey I: lifetime prevalence, chronicity and recurrence, *J Affect Disord* 29:85, 1993.
280. **Busch CM, Zonderman AB, Costa PT Jr**, Menopausal transition and psychological distress in a nationally representative sample: is menopause associated with psychological distress?, *J Aging Health* 6:209, 1994.
281. **Dennerstein L, Smith AMA, Morse C**, Psychological well-being, mid-life and the menopause, *Maturitas* 20:1, 1994.
282. **Mitchell ES, Woods NF**, Symptom experiences of midlife women: observations from the Seattle midlife women's health study, *Maturitas* 25:1, 1996.
283. **Van Hall EV, Verdel M, Van Der Velden J**, "Perimenopausal" complaints in women and men: a comparative study, *J Womens Health* 3:45, 1994.
284. **Calvaresi E, Bryan J**, Symptom experience in Australian men and women in midlife, *Maturitas* 44:225, 2003.
285. **Kim MJ, Yim G, Park HY**, Vasomotor and physical menopausal symptoms are associated with sleep quality, *PLoS One* 13(2):e0192934, 2018.
286. **Shaver JL, Woods NF**, Sleep and menopause: a narrative review, *Menopause* 22(8):899, 2015.
287. **Bromberger JT, Schott LL, Avis NE, Crawford SL, Harlow SD, Joffe H, Kravitz HM, Matthews KA**, Psychosocial and health-related risk factors for depressive symptom trajectories among midlife women over 15 years: Study of Women's Health Across the Nation (SWAN), *Psychol Med* 49(2):250, 2018.
288. **Chung HF, Pandeya N, Dobson AJ, Kuh D, Brunner EJ, Crawford SL, Avis NE, Gold EB, Mitchell ES, Woods NF, Bromberger JT, Thurston RC, Joffe H, Yoshizawa T, Anderson D, Mishra GD**, The role of sleep difficulties in the vasomotor menopausal symptoms and depressed mood relationships: an international pooled analysis of eight studies in the InterLACE consortium, *Psychol Med* 48(15):2550, 2018.
289. **Guthrie KA, Larson JC, Ensrud KE, Anderson GL, Carpenter JS, Freeman EW, Joffe H, LaCroix AZ, Manson JE, Morin CM, Newton KM, Otte J, Reed SD, McCurry SM**, Effects of pharmacologic and nonpharmacologic interventions on insomnia symptoms and self-reported sleep quality in women with hot flashes: a pooled analysis of individual participant data from four MsFLASH trials, *Sleep* 41(1), 2018. doi: 10.1093/sleep/zsx190.
290. **Freeman EW, Sammel MD, Lin HM, Nelson DB**, Associations of hormones and menopausal status with depressed mood in women with no history of depression, *Arch Gen Psychiatry* 63:375, 2006.
291. **Cohen LS, Soares CN, Vitonis AF, Otto MW, Harlow BL**, Risk for new onset of depression during the menopausal transition. The Harvard Study of Moods and Cycles, *Arch Gen Psychiatry* 63:385, 2006.
292. **Bromberger JT, Kravits HM, Matthews K, Youk A, Brown C, Feng W**, Predictors of first lifetime episodes of major depression in midlife women, *Psychol Med* 39:55, 2009.
293. **Kravitz HM, Janssen I, Bromberger JT, Matthews KA, Hall MH, Ruppert K, Joffe H**, Sleep

trajectories before and after the final menstrual period in the Study of Women's Health Across the Nation (SWAN), *Curr Sleep Med Rep* 3(3):235, 2017.

294. **Prairie BA, Wisniewski SR, Luther J, Hess R, Thurston RC, Wisner KL, Bromberger JT**, Symptoms of depressed mood, disturbed sleep, and sexual problems in midlife women: cross-sectional data from the Study of Women's Health Across the Nation, *J Womens Health (Larchmt)* 24(2):119, 2015.
295. **Campbell S, Whitehead M**, Estrogen therapy and the menopausal syndrome, *Clin Obstet Gynecol* 4:31, 1977.
296. **Avis NE, Crawford S, Stellato R, Longcope C**, Longitudinal study of hormone levels and depression among women transitioning through menopause, *Climacteric* 4:243, 2001.
297. **Kuh DL, Wadsworth M, Hardy R**, Women's health in midlife: the influence of the menopause, social factors and health in earlier life, *Br J Obstet Gynaecol* 104:923, 1997.
298. **Wiklund I, Karlberg J, Mattsson L-A**, Quality of life of postmenopausal women on a regimen of transdermal estradiol therapy: a double-blind placebo-controlled study, *Am J Obstet Gynecol* 168:824, 1993.
299. **Daly E, Gray A, Barlow D, McPherson K, Roche M, Vessey M**, Measuring the impact of menopausal symptoms on quality of life, *Br Med J* 307:836, 1993.
300. **Hlatky MA, Boothroyd D, Vittinghoff E, Sharp P, Whooley MA**; for the **HERS Research Group**, Quality-of-life and depressive symptoms in postmenopausal women after receiving hormone therapy. Results from the Heart and Estrogen/progestin Replacement Study (HERS) trial, *JAMA* 287:591, 2002.
301. **Hays J, Ockene JK, Brunner RL, Kotchen JM, Manson JE, Patterson RE, Aragaki AK, Shumaker SA, Brzyski RG, LaCroix AZ, Granek IA, Valanis BG**; **Women's Health Initiative Investigators**, Effects of estrogen plus progestin on health-related quality of life, *N Engl J Med* 348:1839, 2003.
302. **Welton AJ, Vickers MR, Kim JJ, Ford D, Lawton BA, MacLennan AH, Meredith SK, Martin J, Meade TW**; for the **WISDOM team**, Health related quality of life after combined hormone replacement therapy: randomised controlled trial, *Br Med J* 337:a119, 2008. doi: 10.1136/bmj.a1190.
303. **Woodward S, Freedman RR**, The thermoregulatory effects of menopausal hot flashes on sleep, *Sleep* 17:497, 1994.
304. **Freedman RR, Roehrs TA**, Effects of REM sleep and ambient temperature on hot flash-induced sleep disturbance, *Menopause* 13:576, 2006.
305. **Ensrud KE, Stone KL, Blackwell TL, Sawaya GF, Tagliaferri M, Diem SJ, Grady D**, Frequency and severity of hot flashes and sleep disturbance in postmenopausal women with hot flashes, *Menopause* 16:286, 2009.
306. **Schiff I, Regestein Q, Tulchinsky D, Ryan KJ**, Effects of estrogens on sleep and psychological state of hypogonadal women, *JAMA* 242:2405, 1979.
307. **Polo-Kantola P, Erkkola R, Helenius H, Irjala K, Polo O**, When does estrogen replacement therapy improve sleep quality?, *Am J Obstet Gynecol* 178:1002, 1998.
308. **Kravitz HM, Ganz PA, Bromberger J, Powell LH, Sutton-Tyrrell K, Meyer PM**, Sleep difficulty in women at midlife: a community survey of sleep and the menopausal transition, *Menopause* 10:19, 2003.
309. **Kravitz HM, Zhao X, Bromberger JT, Gold EB, Hall MH, Matthews KA, Sowers MR**, Sleep disturbance during the menopausal transition in a multi-ethnic community sample of women, *Sleep* 31:979, 2008.
310. **Dennerstein L, Burrows GD, Hyman GJ, Wood C**, Hormone therapy and affect, *Maturitas* 1:247, 1979.
311. **Sherwin BB**, Affective changes with estrogen and androgen replacement therapy in surgically menopausal women, *J Affect Disord* 14:177, 1988.
312. **Palinkas LA, Barrett-Connor E**, Estrogen use and depressive symptoms in postmenopausal women, *Obstet Gynecol* 80:30, 1992.
313. **Limouzin-Lamothe M-A, Mairon N, Joyce CRB, Le Gal M**, Quality of life after the menopause: influence of hormonal replacement therapy, *Am J Obstet Gynecol* 170:618, 1994.
314. **Tosteson AN, Gabriel SE, Kneeland TS, Moncur MM, Manganiello PD, Schiff I, Ettinger B, Melton LJ III**, Has the impact of hormone replacement therapy on health-related quality of life been undervalued?, *J Womens Health Gend Based Med* 9:119, 2000.
315. **Schneider LS, Small GW, Hamilton SH, Bystritsky A, Nemeroff CB, Meyers BS**; the **Fluoxetine**

- Collaborative Study Group**, Estrogen replacement and response to fluoxetine in a multicenter geriatric depression trial, *Am J Geriatr Psychiatry* 5:97, 1997.
316. **de Novaes Soares C, Almeida OP, Joffe H, Cohen LS**, Efficacy of estradiol for the treatment of depressive disorders in perimenopausal women. A double-blind, randomized, placebo-controlled trial, *Arch Gen Psychiatry* 58:529, 2001.
  317. **Schmidt PJ, Nieman LK, Danaceau MA, Tobin MB, Roca CA, Murphy JH, Rubinow DR**, Estrogen replacement in perimenopause-related depression: a preliminary report, *Am J Obstet Gynecol* 183:414, 2000.
  318. **Gregoire AJ, Kumar R, Everitt B, Henderson AF, Studd JW**, Transdermal oestrogen for treatment of severe postnatal depression, *Lancet* 347:930, 1996.
  319. **Ahokas A, Kaukoranta J, Wahlbeck K, Aito M**, Estrogen deficiency in severe postpartum depression: successful treatment with sublingual physiologic 17beta-estradiol: a preliminary study, *J Clin Psychiatry* 62:332, 2001.
  320. **Bromberger JT, Assmann SF, Avis NE, Schocken M, Kravitzl HM, Cordal A**, Persistent mood symptoms in a multiethnic community cohort of pre- and perimenopausal women, *Am J Epidemiol* 158:347, 2003.
  321. **Sherwin BB**, Estrogen effects on cognition in menopausal women, *Neurol* 48(Suppl 7):S21, 1997.
  322. **Rice MM, Graves AB, Mcurry SM, Larson EB**, Estrogen replacement therapy and cognitive function in postmenopausal women without dementia, *Am J Med* 103(3A):26S, 1997.
  323. **Ditkoff EC, Crary WG, Cristo M, Lobo RA**, Estrogen improves psychological function in asymptomatic postmenopausal women, *Obstet Gynecol* 78:991, 1991.
  324. **Polo-Kantola P, Portin R, Polo O, Helenius H, Irjala K, Erkkola R**, The effect of short-term estrogen replacement therapy on cognition: a randomized, double-blind, cross-over trial in postmenopausal women, *Obstet Gynecol* 91:459, 1998.
  325. **Henderson VW, Guthrie JR, Dudley EC, Burger HG, Dennerstein L**, Estrogen exposures and memory at midlife: a population-based study of women, *Neurology* 60:1369, 2003.
  326. **Meyer PM, Powell LH, Wilson RS, Everson-Rose SA, Kravitz HM, Luborsky JL, Madden T, Pandey D, Evans DA**, A population-based longitudinal study of cognitive functioning in the menopausal transition, *Neurology* 61:801, 2003.
  327. **Phillips SM, Sherwin BB**, Effects of estrogen on memory function in surgically menopausal women, *Psychoneuroendocrinology* 17:485, 1992.
  328. **Kampen DL, Sherwin BB**, Estrogen use and verbal memory in healthy postmenopausal women, *Obstet Gynecol* 83:979, 1994.
  329. **Smith YR, Giordani B, Lajiness-O'Neill R, Zubieta J-K**, Long-term estrogen replacement is associated with improved nonverbal memory and attentional measures in postmenopausal women, *Fertil Steril* 76:1101, 2001.
  330. **Robinson D, Friedman L, Marcus R, Tinklenberg J, Yesavage J**, Estrogen replacement therapy and memory in older women, *J Am Geriatr Soc* 42:919, 1994.
  331. **Resnick SM, Metter EJ, Zonderman AB**, Estrogen replacement therapy and longitudinal decline in visual memory. A possible protective effect, *Neurology* 49:1491, 1997.
  332. **Maki PM, Zonderman AB, Resnick SM**, Enhanced verbal memory in nondemented elderly women receiving hormone-replacement therapy, *Am J Psychiatry* 158:227, 2001.
  333. **Jacobs DM, Tang MX, Stern Y, Sano M, Marder K, Bell KL, Schofield P, Dooneief G, Gurland B, Mayeux R**, Cognitive function in nondemented older women who took estrogen after menopause, *Neurology* 50:368, 1998.
  334. **Matthews K, Cauley J, Yaffe K, Zmuda JM**, Estrogen replacement therapy and cognitive decline in older community women, *J Am Geriatr Soc* 47:518, 1999.
  335. **Shaywitz SE, Naftolin F, Zelterman D, Marchione KE, Holahan JM, Palter SF, Shaywitz BA**, Better oral reading and short-term memory in midlife, postmenopausal women taking estrogen, *Menopause* 10:420, 2003.
  336. **Yaffe K, Lui L-Y, Grady D, Cauley J, Kramer J, Cummings SR**, Cognitive decline in women in relation to

non-protein-bound oestradiol concentrations, *Lancet* 356:708, 2000.

337. **Yaffe K, Haan M, Byers A, Tangen C, Kuller L**, Estrogen use, APOE, and cognitive decline. Evidence of gene-environment interaction, *Neurology* 54:1949, 2000.
338. **Behl C, Skutella T, Lezoualc'h F, Post A, Widmann M, Newton CJ, Holsboer F**, Neuroprotection against oxidative stress by estrogens: structure-activity relationship, *Mol Pharm* 51:535, 1997.
339. **Hashimoto S, Katou M, Dong Y, Murakami K, Terada S, Inoue M**, Effects of hormone replacement therapy on serum amyloid P component in postmenopausal women, *Maturitas* 26:113, 1997.
340. **Wooley CS, Weiland NG, McEwen BS, Schwartzkroin PA**, Estradiol increases the sensitivity of hippocampal CA1 pyramidal cells to NMDA receptor-mediated synaptic input: correlation with dendritic spine density, *J Neurosci* 17:1848, 1997.
341. **Rhodin JA, Thomas TN, Clark L, Garces A, Bryant M**, In vivo cerebrovascular actions of amyloid beta-peptides and the protective effect of conjugated estrogens, *J Alzheimers Dis* 5:275, 2003.
342. **Zhao L, Chen S, Brinton RD**, An estrogen replacement therapy containing nine synthetic plant-based conjugated estrogens promotes neuronal survival, *Exp Biol Med* 228:823, 2003.
343. **Diaz Brinton R, Chen S, Montoya M, Hsieh D, Minaya J, Kim J, Chu HP**, The Women's Health Initiative estrogen replacement therapy is neurotrophic and neuroprotective, *Neurobiol Aging* 21:475, 2003.
344. **Paganini-Hill A, Henderson VW**, Estrogen replacement therapy and risk of Alzheimer disease, *Arch Intern Med* 156:2213, 1996.
345. **Henderson VW**, The epidemiology of estrogen replacement therapy and Alzheimer's disease, *Neurol* 48(Suppl 7):S27, 1997.
346. **Waring SC, Rocca WA, Petersen RC, O'Brien PC, Tangalos EG, Kokmen E**, Postmenopausal estrogen replacement therapy and risk of AD. A population-based study, *Neurology* 52:965, 1999.
347. **Kawas C, Resnick S, Morrison A, Brookmeyer R, Corrada M, Zonderman A, Bacal C, Lingle D, Metter E**, A prospective study of estrogen replacement therapy and the risk of developing Alzheimer's disease: the Baltimore Longitudinal Study of Aging, *Neurology* 48:1517, 1997.
348. **Tang M-X, Jacobs D, Stern Y, Marder K, Schofield P, Gurland B, Andrews H, Mayeux R**, Effect of oestrogen during menopause on risk and age of onset of Alzheimer's disease, *Lancet* 348:429, 1996.
349. **Baldereschi M, Di Carlo A, Lepore V, Bracco L, Maggi S, Grigoletto F, Scarlato G, Amaducci L; for the ILSA Working Group**, Estrogen-replacement therapy and Alzheimer's disease in the Italian Longitudinal Study on Aging, *Neurol* 50:996, 1998.
350. **Seshadri S, Zornberg GL, Derby LE, Meyers MW, Jick H, Drachman DA**, Postmenopausal estrogen replacement therapy and the risk of Alzheimer disease, *Arch Neurol* 58:435, 2001.
351. **Henderson V, Paganini-Hill A, Emanuel CK, Dunn ME, Buckwalter G**, Estrogen replacement therapy in older women: comparisons between Alzheimer's disease cases and nondemented control subjects, *Arch Neurol* 51:896, 1994.
352. **Henderson VW, Paganini-Hill A, Miller BL, Elble RJ, Reyes PF, Shoupe D, McCleary CA, Klein RA, Hake AM, Farlow MR**, Estrogen for Alzheimer's disease in women: randomized, double-blind, placebo-controlled trial, *Neurology* 54:295, 2000.
353. **Wang PN, Liao SQ, Liu RS, Liu CY, Chao HT, Lu SR, Yu HY, Wang SJ, Liu HC**, Effects of estrogen on cognition, mood, and cerebral blood flow in AD: a controlled study, *Neurology* 54:2061, 2000.
354. **Mulnard RA, Cotman CW, Kawas C, van Dyck CH, Sano M, Doody R, Koss E, Pfeiffer E, Jin S, Gamst A, Grundman M, Thomas R, Thal LJ**, Estrogen replacement therapy for treatment of mild to moderate Alzheimer disease: a randomized controlled trial. Alzheimer's Disease Cooperative Study, *JAMA* 284:1007, 2000.
355. **Asthani S, Craft S, Baker LD, Raskind MA, Birnbaum RS, Lofgreen CP, Veith RC, Plymate SR**, Cognitive and neuroendocrine response to transdermal estrogen in postmenopausal women with Alzheimer's disease: results of a placebo-controlled, double-blind, pilot study, *Psychoneuroendocrinology* 24:657, 1999.
356. **Yoon BK, Kim DK, Kang Y, Kim JW, Shin MH, Na DL**, Hormone replacement therapy in postmenopausal women with Alzheimer's disease: a randomized, prospective study, *Fertil Steril* 79:274, 2003.
357. **Schneider LS, Farlow MR, Henderson VW, Pogoda J**, Effects of estrogen replacement therapy on

- response to tacrine in patients with Alzheimer's disease, *Neurology* 46:1580, 1996.
358. **Hogervorst E, Yaffe K, Richards M, Huppert FA**, Hormone replacement therapy to maintain cognitive function in women with dementia, *Cochrane Database Syst Rev* (1):CD003799, 2009.
  359. **Zandi PP, Carlson MC, Plassman BL, Welsh-Bohmer KA, Mayer LS, Steffens DC, Breitner JCS**; for the **Cache County Memory Study Investigators**, Hormone replacement therapy and incidence of Alzheimer disease in older women. The Cache County Study, *JAMA* 288:2123, 2002.
  360. **Steffens DC, Norton MC, Plassman BL, Tschanz JT, Wyse BW, Welsh-Bohmer KA, Anthony JC, Breitner JCS**, Enhanced cognitive performance with estrogen use in nondemented community-dwelling older women, *J Am Geriatr Soc* 47:1171, 1999.
  361. **Shumaker SA, Legault C, Rapp SR, Thal L, Wallace RB, Ockene JK, Hendrix SL, Jones BN III, Assaf AR, Jackson RD, Kotchen JM, Wassertheil-Smoller S, Wactawski-Wende J**; for the **WHIMS Investigators**, Estrogen plus progestin and the incidence of dementia and mild cognitive impairment in postmenopausal women. The Women's Health Initiative Memory Study: a randomized controlled trial, *JAMA* 289:2651, 2003.
  362. **Rapp SR, Espeland MA, Shumaker SA, Henderson VW, Brunner RL, Manson JE, Gass MLS, Stefanick ML, Lande DS, Hays J, Johnson KC, Coker LH, Dailey M, Bowen D**; for the **WHIMS Investigators**, Effect of estrogen plus progestin on global cognitive function in postmenopausal women. The Women's Health Initiative Memory Study: a randomized controlled trial, *JAMA* 289:2663, 2003.
  363. **Espeland MA, Rapp SR, Shumaker SA, Brunner RL, Manson JE, Sherwin BB, Hsia J, Margolis KL, Hogan PE, Wallace R, Dailey M, Freeman R, Hays J**; **Women's Health Initiative Memory Study**, Conjugated equine estrogens and global cognitive function in postmenopausal women: Women's Health Initiative Memory Study, *JAMA* 291:2959, 2004.
  364. **Resnick SM, Espeland MA, Jaramillo SA, Hirsch C, Stefanick ML, Murray AM, Ockene J, Davatzikos C**; for the **Women's Health Initiative Memory Study**, Postmenopausal hormone therapy and regional brain volumes. The WHIMS-MRI study, *Neurology* 72:135, 2009.
  365. **Coker LH, Hogan PE, Bryan NR, Kuller LH, Margolis KL, Bettermann K, Wallace RB, Lao Z, Freeman R, Stefanick ML, Shumaker SA**; for the **Women's Health Initiative Memory Study**, Postmenopausal hormone therapy and subclinical cerebrovascular disease. The WHIMS-MRI study, *Neurology* 72:125, 2009.
  366. **Erickson KI, Collcombe SJ, Raz N, Korol DL, Scalf P, Webb A, Cohen NJ, McAuley E, Kramer AF**, Selective sparing of brain tissue in postmenopausal women receiving hormone replacement therapy, *Neurobiol Aging* 26:1205, 2005.
  367. **Ghidoni R, Boccardi M, Benussi L, Testa C, Villa A, Pievani M, Gigola L, Sabbatoli F, Barbiero L, Frisoni GB, Binetti G**, Effects of estrogens on cognition and brain morphology: involvement of the cerebellum, *Maturitas* 54:222, 2006.
  368. **Lord C, Buss C, Lupien SJ, Pruessner JC**, Hippocampal volumes are larger in postmenopausal women using estrogen therapy compared to past users, never users and men: a possible window of opportunity effect, *Neurobiol Aging* 29:95, 2008.
  369. **Gleason CE, Dowling NM, Wharton W, Manson JE, Miller VM, Atwood CS, Brinton EA, Cedars MI, Lobo RA, Merriam GR, Neal-Perry G, Santoro NF, Taylor HS, Black DM, Budoff MJ, Hodis HN, Naftolin F, Harman SM, Asthana S**, Effects of hormone therapy on cognition and mood in recently postmenopausal women: findings from the randomized, controlled KEEPS-cognitive and affective study, *PLoS Med* 12(6):e1001833, 2015.
  370. **Kantarci K, Lowe VJ, Lesnick TG, Tosakulwong N, Bailey KR, Fields JA, Shuster LT, Zuk SM, Senjem ML, Mielke MM, Gleason C, Jack CR, Rocca WA, Miller VM**, Early postmenopausal transdermal 17beta-estradiol therapy and amyloid-beta deposition, *J Alzheimers Dis* 53(2):547, 2016.
  371. **Brinton RD**, The healthy cell bias of estrogen action: mitochondrial bioenergetics and neurological implications, *Trends Neurosci* 31:529, 2008.
  372. **National Heart, Lung, and Blood Institute**, Heart Disease in Women, <https://www.nhlbi.nih.gov/health-topics/heart-disease-women>, 2018.

373. **Clarkson TB, Prichard RW, Morgan TM, Petrick GS, Klein KP**, Remodeling of coronary arteries in human and nonhuman primates, *JAMA* 271:289, 1994.
374. **Galis ZS, Khatri JJ**, Matrix metalloproteinases in vascular remodelling and atherogenesis. The good, the bad and the ugly, *Circ Res* 90:251, 2002.
375. **Umetani M, Domoto H, Gormley AK, Yuhanna IS, Cummins CL, Javitt NB, Korach KS, Shaul PW, Mangelsdorf DJ**, 27-Hydroxycholesterol is an endogenous SERM that inhibits the cardiovascular effects of estrogen, *Nat Med* 13:1185, 2007.
376. **Matthews KA, Meilahn E, Kuller LH, Kelsey SF, Caggiula AW, Wing RR**, Menopause and risk factors for coronary heart disease, *N Engl J Med* 321:641, 1989.
377. **Campos H, McNamara JR, Wilson PW, Ordovas JM, Schaefer EJ**, Differences in low density lipoprotein subfractions and apolipoproteins in premenopausal and postmenopausal women, *J Clin Endocrinol Metab* 67:30, 1988.
378. **Jensen J, Nilas L, Christiansen C**, Influence of menopause on serum lipids and lipoproteins, *Maturitas* 12:321, 1990.
379. **Stevenson JC, Crook D, Godsland IF**, Influence of age and menopause on serum lipids and lipoproteins in healthy women, *Atherosclerosis* 98:83, 1993.
380. **Matthews KA, Crawford SL, Chae CU, Everson-Rose SA, Sowers MF, Sternfeld B, Sutton-Tyrrell K**, Are changes in cardiovascular disease risk factors in midlife women due to chronological aging or to the menopausal transition?, *J Am Coll Cardiol* 54:2366, 2009.
381. **van Beresteijn ECH, Korevaar JC, Huijbregts PCW, Schouten EG, Burema J, Kok FJ**, Perimenopausal increase in serum cholesterol: a 10-year longitudinal study, *Am J Epidemiol* 137:383, 1993.
382. **Matthews KA, Wing RR, Kuller LH, Meilahn EN, Plantinga P**, Influence of the perimenopause on cardiovascular risk factors and symptoms of middle-aged healthy women, *Arch Intern Med* 154:2349, 1994.
383. **Bruschi F, Meschia M, Soma M, Perotti D, Paoletti R, Crosignani PG**, Lipoprotein(a) and other lipids after oophorectomy and estrogen replacement therapy, *Obstet Gynecol* 88:950, 1996.
384. **Brunner D, Weisbort J, Meshulam N, Schwartz S, Gross J, Saltz-Rennert H, Altman S, Loebl K**, Relation of serum total cholesterol and high-density lipoprotein cholesterol percentage to the incidence of definite coronary events: twenty-year follow-up of the Donolo-Tel Aviv Prospective Coronary Artery Disease Study, *Am J Cardiol* 59:1271, 1987.
385. **Jacobs DR Jr, Mebane IL, Bangdiwala SI, Criqui MH, Tyroler HA**, High density lipoprotein cholesterol as a predictor of cardiovascular disease mortality in men and women: the follow-up study of the Lipid Research Clinics Prevalence Study, *Am J Epidemiol* 131:32, 1990.
386. **Hulley SB, Newman TB**, Cholesterol in the elderly: is it important?, *JAMA* 272:1372, 1994.
387. **Kannel WB**, Metabolic risk factors for coronary heart disease in women: perspective from the Framingham Study, *Am Heart J* 114:413, 1987.
388. **Downs JR, Clearfield M, Weis S, Whitney E, Shapiro DR, Beere PA, Langendorfer A, Stein EA, Kruyer W, Gotto AM Jr; for the AFCAPS/TextCAPS Research Group**, Primary prevention of acute coronary events with lovastatin in men and women with average cholesterol levels. Results of AFCAPS/TextCAPS, *JAMA* 279:1615, 1998.
389. **Bittner V, Simon JA, Fong J, Blumenthal RS, Newby K, Stefanick ML**, Correlates of high HDL cholesterol among women with coronary heart disease, *Am Heart J* 139:288, 2000.
390. **Ford ES, Giles WH, Dietz WH**, Prevalence of the metabolic syndrome among U.S. adults. Findings from the Third National Health and Nutrition Examination Survey, *JAMA* 287:356, 2002.
391. **Park YW, Zhu S, Palaniappan L, Heshka S, Carnethon MR, Heymsfield SB**, The metabolic syndrome: prevalence and associated risk factor findings in the US population from the Third National Health and Nutrition Examination Survey, 1988–1994, *Arch Intern Med* 163:427, 2003.
392. **Alberti KG, Eckel RH, Grundy SM, Zimmet PZ, Cleeman JI, Donato KA, Fruchart JC, James WP, Loria CM, Smith SC Jr; International Diabetes Federation Task Force on Epidemiology and Prevention; National Heart, Lung, and Blood Institute; American Heart Association; World Heart Federation; International Atherosclerosis Society; International Association for the Study of**



**Obesity**, Harmonizing the metabolic syndrome: a joint interim statement of the International Diabetes Federation Task Force on Epidemiology and Prevention; National Heart, Lung, and Blood Institute; American Heart Association; World Heart Federation; International Atherosclerosis Society; and International Association for the Study of Obesity, *Circulation* 120:1640, 2009.

393. **Janssen I, Powell LH, Crawford S, Lasley B, Sutton-Tyrrell K**, Menopause and the metabolic syndrome: the Study of Women's Health Across the Nation (SWAN), *Arch Intern Med* 168:1568, 2008.
394. **Torréns JI, Sutton-Tyrrell K, Zhao X, Matthews K, Brockwell S, Sowers M, Santoro N**, Relative androgen excess during the menopausal transition predicts incident metabolic syndrome in midlife women: study of women's health across the nation, *Menopause* 16:257, 2009.
395. **Lapidus L, Bengtsson C, Larsson B, Pennert K, Rybo E, Sjöstrom L**, Distribution of adipose tissue and risk of cardiovascular disease and death: a 12 year follow up of participants in the population study of women in Gothenburg, *Br Med J* 289:1257, 1984.
396. **Haarbo J, Hassager C, Riis BJ, Christiansen C**, Relation of body fat distribution to serum lipids and lipoproteins in elderly women, *Atherosclerosis* 80:57, 1989.
397. **Soler JT, Folsom AR, Kaye SA, Prineas RJ**, Associations of abdominal adiposity, fasting insulin, sex hormone binding globulin and estrogen with lipids and lipoproteins in post-menopausal women, *Atherosclerosis* 79:21, 1989.
398. **Wing R, Matthews K, Kuller L, Meilahn EN, Plantinga PL**, Weight gain at the time of menopause, *Arch Intern Med* 151:97, 1990.
399. **Expert Panel on Detection Evaluation and Treatment of High Blood Cholesterol in Adults**, Executive summary of the third report of the National Cholesterol Education Program (NCEP) expert panel on detection, evaluation, and treatment of high blood cholesterol in adults (Adult Treatment Panel III), *JAMA* 285:2486, 2001.
400. **LaRosa JC, He J, Vupputuri S**, Effect of statins on risk of coronary disease: a meta-analysis of randomized controlled trials, *JAMA* 282:2340, 1999.
401. **Mostaghel E, Waters D**, Women do benefit from lipid lowering: latest clinical trial data, *Cardiol Rev* 11:4, 2003.
402. **Barker DJP, Martyn CN, Osmond C, Hales CN, Fall CHD**, Growth in utero and serum cholesterol concentrations in adult life, *Br Med J* 307:1524, 1993.
403. **Fall CHD, Osmond C, Barker DJP, Clark PMS, Hales CN, Stirling Y, Meade TW**, Fetal and infant growth and cardiovascular risk factors in women, *Br Med J* 310:428, 1995.
404. **Ross R**, Atherosclerosis—an inflammatory disease, *N Engl J Med* 340:115, 1999.
405. **Ridker P, Cushman M, Stampfer MJ, Tracy RP, Hennekens CH**, Inflammation, aspirin and the risk of cardiovascular disease in apparently healthy men, *N Engl J Med* 336:973, 1997.
406. **Ridker PM, Buring JE, Shih J, Matias M, Hennekens CH**, A prospective study of C-reactive protein and the risk of future cardiovascular events among apparently healthy women, *Circulation* 98:731, 1998.
407. **Ridker PM, Hennekens CH, Buring JE, Rifai N**, C-reactive protein and other markers of inflammation in the prediction of cardiovascular disease in women, *N Engl J Med* 342:836, 2000.
408. **Ridker PM, Rifai N, Rose L, Buring JE, Cook NR**, Comparison of C-reactive protein and low-density lipoprotein cholesterol levels in the prediction of first cardiovascular events, *N Engl J Med* 347:1557, 2002.
409. **Albert MA, Ridker PM**, The role of C-reactive protein in cardiovascular disease risk, *Curr Cardiol Reports* 1:99, 1999.
410. **Kaplan RC, McGinn AP, Baird AE, Hendrix SL, Kooperberg C, Lynch J, Rosenbaum DM, Johnson KC, Strickler HD, Wassertheil-Smoller S**, Inflammation and hemostasis biomarkers for predicting stroke in postmenopausal women: the Women's Health Initiative Observational Study, *J Stroke Cerebrovasc Dis* 17(6):344, 2008.
411. **Danesh J, Whincup P, Walker M, Lennon L, Thomson A, Appleby P, Gallimore JR, Pepys MB**, Low grade inflammation and coronary heart disease: prospective study and updated meta-analyses, *Br Med J* 321:199, 2000.
412. **Ridker PM, Rifai N, Pfeffer MA, Sacks F, Braunwald E**, Long-term effects of pravastatin on plasma

concentration of C-reactive protein, *Circulation* 100:230, 1999.

413. **Ridker PM, Rifai N, Pfeffer MA, Sacks FM, Moye LA, Goldman S, Flaker GC, Braunwald E**; for the **Cholesterol and Recurrent Events (CARE) Investigators**, Inflammation, pravastatin, and the risk of coronary events after myocardial infarction inpatients with average cholesterol levels, *Circulation* 98:839, 1998.
414. **Walsh BW, Paul S, Wild RA, Dean RA, Tracy RP, Cox DA, Anderson PW**, The effects of hormone replacement therapy and raloxifene on C-reactive protein and homocysteine in healthy postmenopausal women: a randomized, controlled trial, *J Clin Endocrinol Metab* 85:214, 2000.
415. **de Valk-de Roo GW, Stehouwer CDA, Meijer P, Mijatovic V, Kluff C, Kennemans P, Cohen F, Watts S, Netelenbos C**, Both raloxifene and estrogen reduce major cardiovascular risk factors in healthy postmenopausal women: a 2-year, placebo-controlled study, *Arterioscler Thromb Vasc Biol* 19:2993, 1999.
416. **Prelevic GM, Kwong P, Byrne DJ, Jagroop IA, Ginsburg J, Mikhailidis DP**, A cross-sectional study of the effects of hormone replacement therapy on the cardiovascular disease risk profile in healthy postmenopausal women, *Fertil Steril* 77:945, 2002.
417. **Ridker PM, Hennekens CH, Rifai N, Buring JE, Manson JE**, Hormone replacement therapy and increased plasma concentrations of C-reactive protein, *Circulation* 100:713, 1999.
418. **Cushman M, Legault C, Barrett-Connor E, Stefanick ML, Kessler CJ, Judd HL, Sakkinen PA, Tracy RP**, Effect of postmenopausal hormones on inflammation-sensitive proteins: the Postmenopausal Estrogen/Progestin Interventions (PEPI) study, *Circulation* 100:717, 1999.
419. **Frohlich M, Muhlberger N, Hanke H, Imhof A, Doring A, Pepys MB, Koenig W**, Markers of inflammation in women on different hormone replacement therapies, *Ann Med* 35:353, 2003.
420. **Lacut K, Oger E, Le Gal G, Blouch MT, Abgrall JF, Kerlan V, Scarabin PY, Mottier D**; **SARAH Investigators**, Differential effects of oral and transdermal postmenopausal estrogen replacement therapies on C-reactive protein, *Thromb Haemost* 90:124, 2003.
421. **Koh KK, Ahn JY, Jin DK, Yoon BK, Kim HS, Kim DS, Shin MS, Son JW, Choi IS, Shin EK**, Effects of continuous combined hormone replacement therapy on inflammation in hypertensive and/or overweight postmenopausal women, *Arterioscler Thromb Vasc Biol* 22:1459, 2002.
422. **Silvestri A, Gebara O, Vitale C, Wajngarten M, Leonardo F, Ramieres JA, Fini M, Mercucro G, Rosano GM**, Increased levels of C-reactive protein after oral hormone replacement therapy may not be related to an increased inflammatory response, *Circulation* 107:3165, 2003.
423. **Pradhan AD, Manson JE, Rossouw JE, Siscovick DS, Mouton CP, Rifai N, Wallace RB, Jackson RD, Pettinger MB, Ridker PM**, Inflammatory biomarkers, hormone replacement therapy, and incident coronary heart disease. Prospective analysis from the Women's Health Initiative Observational Study, *JAMA* 288:980, 2002.
424. **Shlipak MG, Simon JA, Vittinghoff E, Lin F, Barrett-Connor E, Knopp RH, Levy RI, Hulley SB**, Estrogen and progestin, lipoprotein(a), and the risk of recurrent coronary heart disease events after menopause, *JAMA* 283:1845, 2000.
425. **McGill HC Jr, McMahan CA, Zieske AW, Sloop GD, Walcott JV, Troxclair DA, Malcom GT, Tracy RE, Oalmann MC, Strong JP**, Associations of coronary heart disease risk factors with the intermediate lesion of atherosclerosis in youth. The Pathobiological Determinants of Atherosclerosis in Youth (PDAY) Research Group, *Arterioscler Thromb Vasc Biol* 20:1998, 2000.
426. **McGill HC Jr, McMahan CA, Malcom GT, Oalmann MC, Strong JP**, Effects of serum lipoproteins and smoking on atherosclerosis in young men and women. The PDAY Research Group, *Arterioscler Thromb Vasc Biol* 17:95, 1997.
427. **van der Schouw YT, van der Graff Y, Steyerberg EW, Eijkemans JC, Banga JD**, Age at menopause as a risk factor for cardiovascular mortality, *Lancet* 347:714, 1996.
428. **de Kleijn MJ, Van der Schouw YT, Verbeek AL, Peeters PH, Banga JD, Van der Graff Y**, Endogenous estrogen exposure and cardiovascular mortality risk in postmenopausal women, *Am J Epidemiol* 155:339, 2002.
429. **Kalantaridou SN, Naka KK, Papanikolaou E, Kazakos N, Kravariti M, Calis KA, Paraskevaidis EA, Sideris DA, Tsatsoulis A, Chrousos GP, Michalis LK**, Impaired endothelial function in young women with premature ovarian failure: normalization with hormone therapy, *J Clin Endocrinol Metab* 89:3907, 2004.

430. **Kalantaridou SN, Naka KK, Bechlioulis A, Makrigiannakis A, Michalis L, Chrousos GP**, Premature ovarian failure, endothelial dysfunction and estrogen-progestogen replacement, *Trends Endocrinol Metab* 17:101, 2006.
431. **Chowienzyk PJ, Watts GF, Cockcroft JR, Brett SE, Ritter JM**, Sex differences in endothelial function in normal and hypercholesterolaemic subjects, *Lancet* 344:305, 1994.
432. **Thurston RC, Sutton-Tyrrell K, Everson-Rose SA, Hess R, Matthews KA**, Hot flashes and subclinical cardiovascular disease: findings from the Study of Women's Health Across the Nation Heart Study, *Circulation* 118:1234, 2008.
433. **He H, Yang F, Liu X, Zeng X, Hu Q, Zhu Q, Tu B**, Sex hormone ratio changes in men and postmenopausal women with coronary artery disease, *Menopause* 14:385, 2007.
434. **Hamelin BA, Methot J, Arsenault M, Pilote S, Poirier P, Plante S, Bogaty P**, Influence of the menstrual cycle on the timing of acute coronary events in premenopausal women, *Am J Med* 114:599, 2003.
435. **Matthews KA, Santoro N, Lasley B, Chang Y, Crawford S, Pasternak RC, Sutton-Tyrrell K, Sowers M**, Relation of cardiovascular risk factors in women approaching menopause to menstrual cycle characteristics and reproductive hormones in the follicular and luteal phases, *J Clin Endocrinol Metab* 91:1789, 2006.
436. **Rickenlund A, Eriksson MJ, Schenck-Gustafsson K, Hirschberg AL**, Amenorrhea in female athletes is associated with endothelial dysfunction and unfavorable lipid profile, *J Clin Endocrinol Metab* 90:1354, 2005.
437. **Rickenlund A, Eriksson MJ, Schenck-Gustafsson K, Hirschberg AL**, Oral contraceptives improve endothelial function in amenorrheic athletes, *J Clin Endocrinol Metab* 90:3162, 2005.
438. **Bairey Merz CN, Johnson BD, Sharaf BL, Bittner V, Berga SL, Braunstein GD, Hodgson TK, Matthews AE, Pepine CJ, Reis SE, Reichek N, Rogers WJ, Pohost GM, Kelsey SF, Sopko G; for the WISE Study Group**, Hypoestrogenemia of hypothalamic origin and coronary artery disease in premenopausal women: a report from the NHLBI-sponsored WISE study, *J Am Coll Cardiol* 41:413, 2003.
439. **Kaplan JR, Adams MR, Anthony MS, Morgan TM, Manuck SB, Clarkson TB**, Dominant social status and contraceptive hormone treatment inhibit atherogenesis in premenopausal monkeys, *Arterioscler Thromb Vasc Biol* 15:2094, 1995.
440. **Kaplan JR, Manuck SB, Anthony MS, Clarkson TB**, Premenopausal social status and hormone exposure predict postmenopausal atherosclerosis in female monkeys, *Am J Obstet Gynecol* 99:381, 2002.
441. **Clarkson TB, Appt S**, Controversies about HRT—lessons from monkey models, *Maturitas* 51:64, 2005.
442. **Bairey Merz CN, Johnson BD, Berga SL, Braunstein G, Reis SE, Bittner V; the WISE Study Group**, Past oral contraceptive use and angiographic coronary artery disease in postmenopausal women: data from the National Heart, Lung, and Blood Institute-sponsored Women's Ischemia Syndrome Evaluation, *Fertil Steril* 85:1425, 2006.
443. **Hanke H, Hanke S, Ickrath O, Lange K, Bruck B, Muck AO, Seeger H, Zwirner M, Voisard R, Haasis R, Hombach V**, Estradiol concentrations in premenopausal women with coronary heart disease, *Coron Artery Dis* 8:511, 1997.
444. **Shively CA, Register TC, Friedman DP, Morgan TM, Thompson J, Lanaier T**, Social stress-associated depression in adult female cynomolgus monkeys (*Macaca fascicularis*), *Biol Psychol* 69:67, 2005.
445. **Agatisa PK, Matthews KA, Bromberger JT, Edmundowicz D, Chang YF, Sutton-Tyrrell K**, Coronary and aortic calcification in women with a history of major depression, *Arch Intern Med* 165:1229, 2005.
446. **Lewis TT, Everson-Rose SA, Colvin A, Matthews K, Bromberger JT, Sutton-Tyrrell K**, Interactive effects of race and depressive symptoms on calcification in African-American and white women, *Psychosom Med* 71:163, 2009.
447. **Clarkson TB, Anthony MS**, Hormone replacement therapy and coronary artery atherosclerosis: the monkey model, *Br J Obstet Gynaecol* 103(Suppl 13):53, 1996.
448. **Karim R, Mack WJ, Lobo RA, Hwang J, Liu C, Liu C, Sevanian A, Hodis HN**, Determinants of the effect of estrogen on the progression of subclinical atherosclerosis: estrogen in the prevention of atherosclerosis trial, *Menopause* 12:366, 2005.
449. **Mendelsohn ME, Karas RH**, Molecular and cellular basis of cardiovascular gender differences, *Science* 308:1583, 2005.

450. **Zhu X, Bonet B, Knopp RH**, Estradiol 17beta inhibition of LDL oxidation and endothelial cell cytotoxicity is opposed by progestins to different degrees, *Atherosclerosis* 148:31, 2000.
451. **Wild RA, Painter PC, Coulson PB, Carruth KB, Ranney GB**, Lipoprotein lipid concentrations and cardiovascular risk in women with polycystic ovary syndrome, *J Clin Endocrinol Metab* 61:946, 1985.
452. **Wild RA, Van Nort JJ, Grubb B, Bachman W, Hartz A, Bartholomew M**, Clinical signs of androgen excess as risk factors for coronary artery disease, *Fertil Steril* 54:255, 1990.
453. **Graf MJ, Richards CJ, Brown V, Meissner L, Dunaif A**, The independent effects of hyperandrogenaemia, hyperinsulinaemia, and obesity on lipid and lipoprotein profiles in women, *Clin Endocrinol* 33:119, 1990.
454. **Conway GS, Agrawal R, Betteridge DJ, Jacobs HS**, Risk factors for coronary artery disease in lean and obese women with polycystic ovary syndrome, *Clin Endocrinol* 37:119, 1992.
455. **Wild RA, Alaupovic P, Parker IJ**, Lipid and apolipoprotein abnormalities in hirsute women. I. The association with insulin resistance, *Am J Obstet Gynecol* 166:1191, 1992.
456. **Talbott E, Guzick DS, Clerici A, Berga S, Detre K, Weimer K, Kuller L**, Coronary heart disease risk factors in women with polycystic ovary syndrome, *Arterioscler Thromb Vasc Biol* 15:821, 1995.
457. **Guzick DS, Talbott EO, Sutton-Tyrrell K, Herzog HC, Kuller LH, Wolfson SK Jr**, Carotid atherosclerosis in women with polycystic ovary syndrome: initial results from a case-control study, *Am J Obstet Gynecol* 174:1224, 1996.
458. **Birdsall MA, Farquhar CM, White HD**, Association between polycystic ovaries and extent of coronary artery disease in women having cardiac catheterization, *Ann Intern Med* 126:32, 1997.
459. **Solomon CG, Hu FB, Dunaif A, Rich-Edwards JE, Stampfer MJ, Willett WC, Speizer FE, Manson JE**, Menstrual cycle irregularity and risk for future cardiovascular disease, *J Clin Endocrinol Metab* 87:2013, 2002.
460. **Liu PY, Death AK, Handelsman DJ**, Androgens and cardiovascular disease, *Endocr Rev* 24:313, 2003.
461. **Muller M, Grobbee DE, den Tonkelaar I, Lamberts SW, Van der Schouw YT**, Endogenous sex hormones and metabolic syndrome in aging men, *J Clin Endocrinol Metab* 90:2618, 2005.
462. **Kupelian V, Page ST, Araujo AB, Travison TG, Bremner WJ, McKinlay JB**, Low sex hormone-binding globulin, total testosterone, and symptomatic androgen deficiency are associated with development of the metabolic syndrome in nonobese men, *J Clin Endocrinol Metab* 91:843, 2006.
463. **Malkin CJ, Pugh PJ, West JN, van Beek EJ, Jones TH, Channer KS**, Testosterone therapy in men with moderate severity heart failure: a double-blind randomized placebo controlled trial, *Eur Heart J* 27:57, 2006.
464. **Lambrinoudaki I, Christodoulakos G, Rizos D, Economou E, Argeitis J, Vlachou S, Creatsa M, Kouskouni E, Botsis D**, Endogenous sex hormones and risk factors for atherosclerosis in healthy Greek postmenopausal women, *Eur J Endocrinol* 154:907, 2006.
465. **Mudali S, Dobs AS, Ding J, Cauley JA, Szklo M, Golden SH; Atherosclerosis Risk in Communities Study**, Endogenous postmenopausal hormones and serum lipids: the atherosclerosis risk in communities study, *J Clin Endocrinol Metab* 90:1202, 2005.
466. **Bernini GP, Moretti A, Sgro M, Argenio GF, Baralascini CO, Cristofani R, Salvetti A**, Influence of endogenous androgens on carotid wall in postmenopausal women, *Menopause* 8:43, 2001.
467. **Golden SH, Maguire A, Ding J, Crouse JR, Cauley JA, Zacur H, Szklo M**, Endogenous postmenopausal hormones and carotid atherosclerosis: a case-control study of the atherosclerosis risk in communities cohort, *Am J Epidemiol* 155:437, 2002.
468. **Clarkson TB**, Estrogen effects on arteries vary with stage of reproductive life and extent of subclinical atherosclerosis progression, *Menopause* 14:373, 2007.
469. **Salpeter SR, Walsh JME, Greyber E, Salpeter EE**, Brief report: coronary heart disease events associated with hormone therapy in younger and older women. A meta-analysis, *J Gen Intern Med* 21:363, 2006.
470. **Salpeter SR, Walsh JME, Greyber E, Ormiston TM, Salpeter EE**, Mortality associated with hormone replacement therapy in younger and older women. A meta-analysis, *J Gen Intern Med* 19:791, 2004.
471. **Vartiainen E, Puska P, Pekkanen J, Tuomilehto J, Jousilahti P**, Changes in risk factors explain changes in mortality from ischaemic heart disease in Finland, *Br Med J* 309:23, 1994.
472. **Vartiainen E, Sarti C, Tuomilehto J, Kuulasmaa K**, Do changes in cardiovascular risk factors explain

changes in mortality from stroke in Finland?, *Br Med J* 310:901, 1995.

473. **Hu FB, Stampfer MJ, Manson JE, Grodstein F, Colditz GA, Speizer FE, Willett WC**, Trends in the incidence of coronary heart disease and changes in diet and lifestyle in women, *N Engl J Med* 343:530, 2000.
474. **El Khoudary SR**, Gaps, limitations and new insights on endogenous estrogen and follicle stimulating hormone as related to risk of cardiovascular disease in women traversing the menopause: a narrative review, *Maturitas* 104:44, 2017.
475. **Medvei VC**, *The History of Clinical Endocrinology*, The Parthenon Publishing Group, New York, 1993.
476. **O'Dowd MJ, Philipp EE**, *The History of Obstetrics and Gynaecology*, The Parthenon Publishing Group, New York, 1994.
477. **Speert H**, *Obstetric & Gynecologic Milestones Illustrated*, The Parthenon Publishing Group, New York, 1996.
478. **Sneider W**, The discovery of oestrogenic hormones, *Br Menopause Soc J* 6:129, 2000.
479. **Fosbery WHS**, Severe climacteric flushings successfully treated by ovarian extract, *Br Med J* 1:1039, 1897.
480. **Servinghaus EL, Evans J**, Clinical observations on the use of an ovarian hormone: amniotin, *Am J Sci* 178:638, 1929.
481. **Parkes AS**, The rise of reproductive endocrinology, 1926–1940, *J Endocrinol* 34:20, 1966.
482. **Maisel AQ**, *The Hormone Quest*, Random House, New York, 1965, p. 44.
483. **Harding FE**, The oral treatment of ovarian deficiency with conjugated estrogens—equine, *West J Surg Obstet Gynecol* 52:31, 1944.
484. **Goebelsmann U, Mashchak CA, Mishell DR Jr**, Comparison of hepatic impact of oral and vaginal administration of ethinyl estradiol, *Am J Obstet Gynecol* 151:868, 1985.
485. **Katzenellenbogen BS**, Biology and receptor interactions of estriol and estriol derivatives in vitro and in vivo, *J Steroid Biochem* 20:1033, 1984.
486. **Lindsay R, Hart DM, MacLean A, Garwood J, Clarkel AC, Kraszewski A**, Bone loss during oestriol therapy in postmenopausal women, *Maturitas* 1:279, 1979.
487. **Devogelaer JP, Lecart C, Dupret P, De Nayer P, Nagant De Deuxchaisnes C**, Long-term effects of percutaneous estradiol on bone loss and bone metabolism in postmenopausal hysterectomized women, *Maturitas* 28:243, 1998.
488. **Lemon HM**, Estriol prevention of mammary carcinoma induced by 7,12-dimethylbenz(a)anthracene, *Cancer Res* 35:1341, 1975.
489. **Melamed M, Castraño E, Notides AC, Sasson S**, Molecular and kinetic basis for the mixed agonist/antagonist activity of estriol, *Mol Endocrinol* 11:1868, 1997.
490. **Fugh-Berman A, Bythrow J**, Bioidentical hormones for menopausal hormone therapy: variation on a theme, *J Gen Intern Med* 22(7):1030, 2007.
491. **Dusteberg S, Nishino Y**, Pharmacokinetic and pharmacological features of oestradiol valerate, *Maturitas* 4:315, 1982.
492. **Ross D, Rees M, Godfree V, Cooper A, Hart D, Kingsland C, Whitehead M**, Randomised crossover comparison of skin irritation with two transdermal oestradiol patches, *Br Med J* 315:288, 1997.
493. **Bhathena RK, Anklesaria BS, Ganatra AM**, Skin reactions with transdermal estradiol therapy in a tropical environment, *Int J Gynecol Obstet* 60:177, 1998.
494. **Archer DF; EstroGel Study Group**, Percutaneous 17beta-estradiol gel for the treatment of vasomotor symptoms in postmenopausal women, *Menopause* 10:516, 2003.
495. **Hedrick RE, Ackerman RT, Koltun WD, Halvorsen MB, Lambrecht LJ**, Transdermal estradiol gel 0.1% for the treatment of vasomotor symptoms in postmenopausal women, *Menopause* 16:132, 2009.
496. **Buster JE, Koltun WD, Pascual MLG, Day WW, Peterson C**, Low-dose estradiol spray to treat vasomotor symptoms. A randomized controlled trial, *Obstet Gynecol* 111:1343, 2008.
497. **Jung-Hoffman C, Kuhl H**, Intra- and interindividual variations in contraceptive steroid levels during 12 treatment cycles: no relation to irregular bleedings, *Contraception* 42:423, 1990.
498. **Colvin PL Jr, Auerbach BJ, Koritnik DR, Hazzard WR, Applebaum-Bowden D**, Differential effects of oral estrogen versus 17b-estradiol on lipoproteins in postmenopausal women, *J Clin Endocrinol Metab* 70:1568, 1990.

499. **Walsh BW, Li H, Sacks FM**, Effects of postmenopausal hormone replacement with oral and transdermal estrogen on high density lipoprotein metabolism, *J Lipid Res* 35:2083, 1994.
500. **Hillard TC, Whicroft SJ, Marsh MS, Ellerington MC, Lees B, Whitehead MI, Stevenson JC**, Long-term effects of transdermal and oral hormone replacement therapy on postmenopausal bone loss, *Osteoporos Int* 4:341, 1994.
501. **Michaëlsson K, Baron JA, Farahmand BY, Johnell O, Magnusson C, Persson P-G, Persson I, Ljunghall S**; On behalf of the **Swedish Hip Fracture Study Group**, Hormone replacement therapy and risk of hip fracture: population based case-control study, *Br Med J* 316:1858, 1998.
502. **Utian WH, Burry KA, Archer DF, Gallagher JC, Boyett RL, Guy MP, Tachon GJ, Chadha-Boreham HK, Bouvet AA**, Efficacy and safety of low, standard, and high dosages of an estradiol transdermal system (Esclim) compared with placebo on vasomotor symptoms in highly symptomatic menopausal patients. The Esclim Study Group, *Am J Obstet Gynecol* 181:71, 1999.
503. **Shifren JL, Desindes S, McIlwain M, Doros G, Mazer NA**, A randomized, open-label, crossover study comparing the effects of oral versus transdermal estrogen therapy on serum androgens, thyroid hormones, and adrenal hormones in naturally menopausal women, *Menopause* 14:985, 2007.
504. **Kraemer GR, Kraemer RR, Ogden BW, Kilpatrick RE, Gimpel TL, Castracane VD**, Variability of serum estrogens among postmenopausal women treated with the same transdermal estrogen therapy and the effect on androgens and sex hormone binding globulin, *Fertil Steril* 79:534, 2003.
505. **Chen F-P, Lee N, Soong Y-K, Huang K-E**, Comparison of transdermal and oral estrogen-progestin replacement therapy: effects on cardiovascular risk factors, *Menopause* 8:347, 2001.
506. **Vehkavaara S, Silveira A, Hakala-Ala-Pietilä T, Virkamäki A, Hovatta O, Hamsten A, Taskinen M-R, Yki-Järvinen H**, Effects of oral and transdermal estrogen replacement therapy on markers of coagulation, fibrinolysis, inflammation and serum lipids and lipoproteins in postmenopausal women, *Thromb Haemost* 85:619, 2001.
507. **Brynhildsen J, Hammar M**, Lipids and clotting factors during low dose transdermal estradiol/norethisterone use, *Maturitas* 50:344, 2005.
508. **Taner MZ, Ozpolat E, Taskiran C, Onan MA, Gursel T, Karabulut E, Gursoy R, Himmetoglu O**, Effects of four different regimens of hormone replacement therapy on hemostatic parameters: a prospective randomized study, *Maturitas* 53:267, 2006.
509. **Lewandoski KC, Komorowski J, Mikhailidis DP, Bienkiewicz M, Tan BK, O'Callaghan CJ, Lewinski A, Prelevic G, Randeve HS**, Effects of hormone replacement therapy type and route of administration on plasma matrix metalloproteinases and their tissue inhibitors in postmenopausal women, *J Clin Endocrinol Metab* 91:3123, 2006.
510. **Post MS, Christella M, Thomassen LG, Van Der Mooren MJ, Van Baal WM, Rosing J, Kenemans P, Stehouwer CD**, Effect of oral and transdermal estrogen replacement therapy on hemostatic variables associated with venous thrombosis: a randomized, placebo-controlled study in postmenopausal women, *Arterioscler Thromb Vasc Biol* 23:1116, 2003.
511. **Oger E, Alhenc-Gelas M, Lacut K, Blouch MT, Roudaut N, Kerlan V, Collet M, Abgrall JF, Aiach M, Scarabin PY, Mottier D**, Differential effects of oral and transdermal estrogen/progesterone regimens on sensitivity to activated protein C among postmenopausal women: a randomized trial, *Arterioscler Thromb Vasc Biol* 23:1671, 2003.
512. **Scarabin PY, Oger E, Plu-Bureau G**, Differential association of oral and transdermal oestrogen-replacement therapy with venous thromboembolism risk, *Lancet* 362:428, 2003.
513. **Straczek C, Oger E, Beau Yon de Jonage-Canonica M, Plu-Bureau G, Conard J, Meyer G, Alhenc-Gelas M, Levesque H, Trillot N, Barrellier MT, Wahl D, Emmerich J, Scarabin PY**, Prothrombotic mutations, hormone therapy, and venous thromboembolism among postmenopausal women: impact of the route of estrogen administration, *Circulation* 112:3495, 2005.
514. **Canonica M, Oger E, Plu-Bureau G, Conard J, Meyer G, Lévesque H, Trillot N, Barrellier MT, Wahl D, Emmerich J, Scarabin PY**; for the **Estrogen and Thromboembolism Risk (ESTHER) Study Group**, Hormone therapy and venous thromboembolism among postmenopausal women. Impact of the route

of estrogen administration and progestogens: the ESTHER study, *Circulation* 115:840, 2007.

515. **Canonico M, Fourier A, Carcaillon L, Olié V, Plu-Bureau G, Oger E, Mesrine S, Boutron-Ruault MC, Clavel-Chapelon F, Scarabin PY**, Postmenopausal hormone therapy and risk of idiopathic venous thromboembolism. Results from the E3N cohort study, *Arterioscler Thromb Vasc Biol* 30(2):340, 2010.
516. **Rossouw JE, Johnson KC, Pettinger M, Cushman M, Sandset PM, Kuller L, Rosendaal F, Rosing J, Wasserthal-Smoller S, Martin LW, Manson JE, Lakshminarayan K, Merino JG, Lynch J**, Tissue factor pathway inhibitor, activated protein C resistance, and risk of ischemic stroke due to postmenopausal hormone therapy, *Stroke* 43(4):952, 2012.
517. **Pradhan AD, Manson JE, Rossouw JE, Siscovick DS, Mouton CP, Rifai N, Wallace RB, Jackson RD, Pettinger MB, Ridker PM**, Inflammatory biomarkers, hormone replacement therapy, and incident coronary heart disease: prospective analysis from the Women's Health Initiative observational study, *JAMA* 288(8):980, 2002.
518. **Sendag F, Karadadas N, Ozsener S, Bilgin O**, Effects of sequential combined transdermal and oral hormone replacement therapies on serum lipid and lipoproteins in postmenopausal women, *Arch Gynecol Obstet* 266:38, 2002.
519. **Dansuk R, Unal O, Karageyim Y, Esim E, Turan C**, Evaluation of the effect of tibolone and transdermal estradiol on triglyceride level in hypertriglyceridemic and normotriglyceridemic postmenopausal women, *Gynecol Endocrinol* 18:233, 2004.
520. **Bukowska H, Stanosz S, Zochowska E, Millo B, Sieja K, Chelstowski K, Naruszewicz M**, Does the type of hormone replacement therapy affect lipoprotein (a), homocysteine, and C-reactive protein levels in postmenopausal women?, *Metabolism* 54:72, 2005.
521. **Sanada M, Tsuda M, Kodama I, Sakashita T, Nakagawa H, Ohama K**, Substitution of transdermal estradiol during oral estrogen-progestin therapy in postmenopausal women: effects on hypertriglyceridemia, *Menopause* 11:331, 2004.
522. **Simonsen MH, Erichsen R, Froslev T, Rungby J, Sorensen HT**, Postmenopausal estrogen therapy and risk of gallstone disease: a population-based case-control study, *Drug Saf* 36(12):1189, 2013.
523. **Vitale C, Gebara O, Mercurio G, Wajngarten M, Silvestri A, Rossini P, Ramires JA, Fiini M, Rosano GM**, Value of C-reactive protein levels and IL-6 in predicting events in women at increased cardiovascular risk, *Maturitas* 50:239, 2005.
524. **Lakoski SG, Brosnihan B, Herrington DM**, Hormone therapy, C-reactive protein, and progression of atherosclerosis: data from the Estrogen Replacement on Progression of Coronary Artery Atherosclerosis (ERA) trial, *Am Heart J* 150:907, 2005.
525. **Riggs BL, Seeman E, Hodgson SF, Taves DR, O'Fallon WM**, Effect of the fluoride/calcium regimen on vertebral fracture occurrence in postmenopausal osteoporosis, *N Engl J Med* 306:446, 1982.
526. **DeVries CS, Bromley SE, Farmer RD**, Myocardial infarction risk and hormone replacement: differences between products, *Maturitas* 53:343, 2006.
527. **Lovre D, Lindsey SH, Mauvais-Jarvis F**, Effect of menopausal hormone therapy on components of the metabolic syndrome, *Ther Adv Cardiovasc Dis* 11(1):33, 2016.
528. **Wild RA, Wu C, Curb JD, Martin LW, Phillips L, Stefanick M, Trevisan M, Manson JE**, Coronary heart disease events in the Women's Health Initiative hormone trials: effect modification by metabolic syndrome: a nested case-control study within the Women's Health Initiative randomized clinical trials, *Menopause* 20(3):254, 2013.
529. **Chu MC, Cospser P, Nakhuda GS, Lobo RA**, A comparison of oral and transdermal short-term estrogen therapy in postmenopausal women with metabolic syndrome, *Fertil Steril* 86:1669, 2006.
530. **Girdler SS, Hinderliter AL, Wells EC, Sherwood A, Grewen KM, Light KC**, Transdermal versus oral estrogen therapy in postmenopausal smokers: hemodynamic and endothelial effects, *Obstet Gynecol* 103:169, 2004.
531. **Mancini F, Persico N, Genazzani AD, Volpe A, Battaglia C, De Aloysio D**, Effects of hormone replacement therapy on plasma viscosity and Doppler variations in postmenopausal non-smokers and heavy smokers, *Gynecol Endocrinol* 20:221, 2005.

532. **Araujo DA, Farias ML, Andrade AT**, Effects of transdermal and oral estrogen replacement on lipids and glucose metabolism in postmenopausal women with type 2 diabetes mellitus, *Climacteric* 5:286, 2002.
533. **Sztefko K, Rogatko I, Milewicz T, Jozef K, Tomasik PJ, Szafran Z**, Effect of hormone therapy on the enteroinsular axis, *Menopause* 12:630, 2005.
534. **Margolis KL, Bonds DE, Roadabough RJ, Tinker L, Phillips LS, Allen C, Bassford T, Burke G, Torrens J, Howard BV; Women's Health Initiative Investigators**, Effect of oestrogen plus progestin on the incidence of diabetes in postmenopausal women: results from the Women's Health Initiative Hormone Trial, *Diabetologia* 47:1175, 2004.
535. **Yüksel H, Odabasi AR, Demircan S, Köseoglu K, Kizilkaya K, Onur E**, Effects of postmenopausal hormone replacement therapy on body fat composition, *Gynecol Endocrinol* 23:99, 2007.
536. **Saucedo R, Basurto L, Zarate A, Martínez C, Hernandez M, Galván R**, Effect of estrogen therapy on insulin resistance and plasminogen activator inhibitor type 1 concentrations in postmenopausal women, *Gynecol Obstet Invest* 64:61, 2007.
537. **Lobo R, March CM, Goebelsmann U, Krauss RM, Mishell DR Jr**, Subdermal estradiol pellets following hysterectomy and oophorectomy, *Am J Obstet Gynecol* 138:714, 1980.
538. **Suhonen S, Sipinen S, Lahteenmaki P, Laine H, Rainio J, Arko H**, Postmenopausal oestrogen replacement therapy with subcutaneous oestradiol implants, *Maturitas* 16:123, 1993.
539. **Notelovitz M**, Estrogen therapy in management of problems associated with urogenital aging: a simple diagnostic test and the effect of the route of hormone administration, *Maturitas* 22(Suppl):S31, 1995.
540. **Rigg LA, Hermann H, Yen SSC**, Absorption of estrogens from vaginal creams, *N Engl J Med* 298:195, 1978.
541. **Pschera H, Hjerpe A, Carlström K**, Influence of the maturity of the vaginal epithelium upon the absorption of vaginally administered estradiol-17b and progesterone in postmenopausal women, *Gynecol Obstet Invest* 27:204, 1989.
542. **Taechakraichana N, Intraragsakul A, Panyakhamlerd K, Numchaisrika P, Limpaphayom K**, Estradiol and follicle-stimulating hormone levels in oophorectomized women using vaginal estrogen, *J Med Assoc Thai* 80:616, 1997.
543. **Handa VL, Bachus KE, Johnston WW, Robboy SJ, Hammond CB**, Vaginal administration of low-dose conjugated estrogens: systemic absorption and effects on the endometrium, *Obstet Gynecol* 84:215, 1994.
544. **Bachmann G, Bouchard C, Hoppe D, Ranganath R, Altomare C, Vieweg A, Graepel J, Helzner E**, Efficacy and safety of low-dose regiments of conjugated estrogens cream administered vaginally, *Menopause* 16:719, 2009.
545. **Schmidt G, Andersson SB, Nordle Ö, Johansson CJ, Gunnarsson PO**, Release of 17-beta-oestradiol from a vaginal ring in postmenopausal women: pharmacokinetic evaluation, *Gynecol Obstet Invest* 38:253, 1994.
546. **Johnston A**, Estrogens—pharmacokinetics and pharmacodynamics with special reference to vaginal administration and the new estradiol formulation—Estring®, *Acta Obstet Gynecol Scand* 75(Suppl 163):16, 1996.
547. **Henriksson L, Stjernquist M, Boquist L, Cedergren I, Selinus I**, A one-year multicenter study of efficacy and safety of a continuous, low-dose, estradiol-releasing vaginal ring (Estring) in postmenopausal women with symptoms and signs of urogenital aging, *Am J Obstet Gynecol* 174:85, 1996.
548. **Naessen T, Rodriguez-Macias K**, Endometrial thickness and uterine diameter not affected by ultralow doses of 17beta-estradiol in elderly women, *Am J Obstet Gynecol* 186:944, 2002.
549. **Rioux JE, Devlin C, Gelfand MM, Steinberg WM, Hepburn DS**, 17Beta-estradiol vaginal tablet versus conjugated equine estrogen vaginal cream to relieve menopausal atrophic vaginitis, *Menopause* 7:156, 2000.
550. **Dugal R, Hesla K, Sordal T, Aase KH, Lilleidet O, Wickstrom E**, Comparison of usefulness of estradiol vaginal tablets and estriol vagitories for treatment of vaginal atrophy, *Acta Obstet Gynecol Scand* 79:292, 2000.
551. **Mattsson LA, Cullberg G, Eriksson O, Knutsson F**, Vaginal administration of low-dose oestradiol—effects on the endometrium and vaginal cytology, *Maturitas* 11:217, 1989.
552. **Manonai J, Theppisai U, Chittacharoen A**, Effect and safety of 17 beta-estradiol tablet in postmenopausal women with urogenital symptoms, *J Med Assoc Thai* 84:1015, 2001.



553. **Bachmann G, Lobo RA, Gut R, Nachtigall L, Notelovitz M**, Efficacy of low-dose estradiol vaginal tablets in the treatment of atrophic vaginitis: a randomized controlled trial, *Obstet Gynecol* 111:67, 2008.
554. **Holmgren PA, Lindskog M, von Schoultz B**, Vaginal rings for continuous low-dose release of oestradiol in the treatment of urogenital atrophy, *Maturitas* 11:55, 1989.
555. **Akrivis C, Varras M, Thodos A, Hadjopoulos G, Bellou A, Antonious N**, Action of 25 microg 17beta-oestradiol vaginal tablets in the treatment of vaginal atrophy in Greek postmenopausal women: clinical study, *Clin Exp Obstet Gynecol* 30:229, 2003.
556. **Notelovitz M, Funk S, Nanavati N, Mazzeo M**, Estradiol absorption from vaginal tablets in postmenopausal women, *Obstet Gynecol* 99:556, 2002.
557. **Labrie F, Cusan L, Gomez J-L, Côté I, Bérubé R, Bélanger P, Martel C, Labrie C**, Effect of one-week treatment with vaginal estrogen preparations on serum estrogen levels in postmenopausal women, *Menopause* 16:30, 2009.
558. **Naessen T, Berglund L, Ulmsten U**, Bone loss in elderly women prevented by ultralow doses of parenteral 17beta-estradiol, *Am J Obstet Gynecol* 177:115, 1997.
559. **Naessen T, Rodriguez-Macias K, Lithell H**, Serum lipid profile improved by ultra-low doses of 17 beta-estradiol in elderly women, *J Clin Endocrinol Metab* 86:2757, 2001.
560. **Santen RJ**, Vaginal administration of estradiol: effects of dose, preparation and timing on plasma estradiol levels, *Climacteric* 18(2):121, 2015.
561. The 2017 hormone therapy position statement of The North American Menopause Society, *Menopause* 24(7):728, 2017.
562. **Le Ray I, Dell'Aniello S, Bonnetain F, Azoulay L, Suissa S**, Local estrogen therapy and risk of breast cancer recurrence among hormone-treated patients: a nested case-control study, *Breast Cancer Res Treat* 135(2):603, 2012.
563. **Speroff L**; for the **United States VR Investigator Group**, Efficacy and tolerability of a novel estradiol vaginal ring for relief of menopausal symptoms, *Obstet Gynecol* 102:823, 2003.
564. **Al-Azzawi F, Buckler HM**; **United Kingdom Vaginal Ring Investigator Group**, Comparison of a novel vaginal ring delivering estradiol acetate versus oral estradiol for relief of vasomotor menopausal symptoms, *Climacteric* 6:118, 2003.
565. **Castelo-Blanco C, de Osaba M, Vanreze JA, Fortuny A, González-Merlo J**, Effects of oophorectomy and hormone replacement therapy on pituitary-gonadal function, *Maturitas* 17:101, 1993.
566. **Woodruff JD, Pickar JH**; for **The Menopause Study Group**, Incidence of endometrial hyperplasia in postmenopausal women taking conjugated estrogens (Premarin) with medroxyprogesterone acetate or conjugated estrogens alone, *Am J Obstet Gynecol* 170:1213, 1994.
567. **Strickland DM, Hammond TL**, Postmenopausal estrogen replacement in a large gynecologic practice, *Am J Gynecol Health* 2:33, 1988.
568. **Archer DF, Pickar JH, Bottigioni F**; for **The Menopause Study Group**, Bleeding patterns in postmenopausal women taking continuous combined or sequential regimens of conjugated estrogens with medroxyprogesterone acetate, *Obstet Gynecol* 83:686, 1994.
569. **The Writing Group for the PEPI Trial**, Effects of estrogen or estrogen/progestin regimens on heart disease risk factors in postmenopausal women: the Postmenopausal Estrogen/Progestin Interventions (PEPI) Trial, *JAMA* 273:199, 1995.
570. **The Writing Group for the PEPI Trial**, Effects of hormone replacement therapy on endometrial histology in postmenopausal women: the Postmenopausal Estrogen/Progestin Interventions (PEPI) Trial, *JAMA* 275:370, 1996.
571. **Speroff L, Rowan J, Symons J, Genant H, Wilborn W**; for the **CHART Study Group**, The comparative effect on bone density, endometrium, and lipids of continuous hormones as replacement therapy (CHART Study), *JAMA* 276:1397, 1996.
572. **Pickar JH, Yeh IT, Wheeler JE, Cunnane MF, Speroff L**, Endometrial effects of lower doses of conjugated equine estrogens and medroxyprogesterone acetate: two-year substudy results, *Fertil Steril* 80:1234, 2003.

573. **King R, Whitehead M**, Assessment of the potency of orally administered progestins in women, *Fertil Steril* 46:1062, 1986.
574. **The Writing Group for the PEPI Trial**, Effects of hormone therapy on bone mineral density: results from the Postmenopausal Estrogen/Progestin Interventions (PEPI) Trial, *JAMA* 276:1389, 1996.
575. **Gillet JY, Andre G, Faguer B, Ernyl R, Buvat-Herbaut M, Domin MA, Kuhn MJM, Hedon B, Drapier-Faure E, Barrat J, Lopes P, Magnin G, Leng JJ, Bruhat MA, Philippe E**, Induction of amenorrhea during hormone replacement therapy: optimal micronized progesterone dose. A multicenter study, *Maturitas* 19:103, 1994.
576. **Recker RR, Davies KM, Dowd RM, Heaney RP**, The effect of low-dose continuous estrogen and progesterone therapy with calcium and vitamin D on bone in elderly women: a randomized, controlled trial, *Ann Intern Med* 130:897, 1999.
577. **Lindsay R, Gallagher JC, Kleerekoper M, Pickar JH**, Effect of lower doses of conjugated equine estrogens with and without medroxyprogesterone acetate on bone in early postmenopausal women, *JAMA* 287:2668, 2002.
578. **Prestwood KM, Thompson DL, Kenny AM, Seibel MJ, Pilbeam CC, Raisz LG**, Low dose estrogen and calcium have an additive effect on bone resorption in older women, *J Clin Endocrinol Metab* 84:179, 1999.
579. **Prestwood KM, Kenny AM, Kleppinger A, Kulldorff M**, Ultralow-dose micronized 17beta-estradiol and bone density and bone metabolism in older women: a randomized controlled trial, *JAMA* 290:1042, 2003.
580. **Utian WH, Shoupe D, Bachmann G, Pinkerton JV, Pickar JH**, Relief of vasomotor symptoms and vaginal atrophy with lower doses of conjugated equine estrogens and medroxyprogesterone acetate, *Fertil Steril* 75:1065, 2001.
581. **Gast MJ, Freedman MA, Vieweg AJ, De Melo NR, Girão MJBC, Zinaman MJ; for the Dyspareunia Study Group**, A randomized study of low-dose conjugated estrogens on sexual function and quality of life in postmenopausal women, *Menopause* 16:247, 2009.
582. **Archer DF, Dorin M, Lewis V, Schneider DL, Pickar JH**, Effects of lower doses of conjugated equine estrogens and medroxyprogesterone acetate on endometrial bleeding, *Fertil Steril* 75:1080, 2001.
583. **Lobo RA, Bush T, Carr BR, Pickar JH**, Effects of lower doses of conjugated equine estrogens and medroxyprogesterone acetate on plasma lipids and lipoproteins, coagulation factors, and carbohydrate metabolism, *Fertil Steril* 76:13, 2001.
584. **Notelovitz M, Lenihan JP Jr, McDermott MP, Kerber IJ, Nanavati N, Arce J-C**, Initial 17beta-estradiol dose for treating vasomotor symptoms, *Obstet Gynecol* 95:726, 2000.
585. **Speroff L, Symons J, Kempfert N, Rowan J; for the FEMHRT Study Investigators**, The effect of varying low-dose combinations of norethindrone acetate and ethinyl estradiol (femhrt) on the frequency and intensity of vasomotor symptoms, *Menopause* 7:383, 2000.
586. **Sturdee DW, Ulrich LG, Barlow DH, Wells M, Campbell MJ, Vessey MP, Nielsen B, Anderson MC, Bragg AJ**, The endometrial response to sequential and continuous combined oestrogen-progestogen replacement therapy, *Br J Obstet Gynaecol* 107:1392, 2000.
587. **Wells M, Sturdee DW, Barlow DH, Ulrich LG, O'Brien K, Campbell MJ, Vessey MP, Bragg AJ; for the UK Continuous Combined Hormone Replacement Therapy Study Investigators**, Effect on endometrium of long term treatment with continuous combined oestrogen-progestogen replacement therapy: follow up study, *Br Med J* 325:239, 2002.
588. **Montplaisier J, Lorrain J, Denesle R, Petit D**, Sleep in menopause: differential effects of two forms of hormone replacement therapy, *Menopause* 8:10, 2001.
589. **Miles RA, Press MF, Paulson RJ, Dahmouh L, Lobo RA, Sauer MV**, Pharmacokinetics and endometrial tissue levels of progesterone after administration by intramuscular and vaginal routes: a comparative study, *Fertil Steril* 62:485, 1994.
590. **Ross D, Cooper AJ, Pryse-Davies J, Bergeron C, Collins WP, Whitehead MI**, Randomized, double-blind, dose-ranging study of the endometrial effects of a vaginal progesterone gel in estrogen-treated postmenopausal women, *Am J Obstet Gynecol* 177:937, 1997.
591. **de Ziegler D, Ferriani R, Moraes L A, Bulletti C**, Vaginal progesterone in menopause: crinone 4% in

cyclical and constant combined regimens, *Hum Reprod* 15(Suppl 1) 149, 2000.

592. **Cicinelli E, de Ziegler D, Alfonso R, Nicoletti R, Bellavia M, Colafiglio G**, Endometrial effects, bleeding control, and compliance with a new postmenopausal hormone therapy regimen based on transdermal estradiol gel and every-other-day vaginal progesterone in capsules: a 3-year pilot study, *Fertil Steril* 83(6):1859, 2005.
593. **Notelovitz M, Cassel D, Hille D, Furst KW, Dain MP, VandePol C, Skarinsky D**, Efficacy of continuous sequential transdermal estradiol and norethindrone acetate in relieving vasomotor symptoms associated with menopause, *Am J Obstet Gynecol* 182:7, 2000.
594. **Shulman LP, Yankov V, Uhl K**, Safety and efficacy of a continuous once-a-week 17beta-estradiol/levonorgestrel transdermal system and its effects on vasomotor symptoms and endometrial safety in postmenopausal women: the results of two multicenter, double-blind, randomized controlled trials, *Menopause* 9:195, 2002.
595. **Rubinacci A, Peruzzi E, Modena AB, Zanardi E, Andrei B, De Leo V, Pansini FS, Quebe-Fehling E, de Palacios PI**, Effect of low-dose transdermal E2/NETA on the reduction of postmenopausal bone loss in women, *Menopause* 10:241, 2003.
596. **Ettinger B, Selby J, Citron JT, Vangessel A, Ettinger V, Hendrickson MR**, Cyclic hormone replacement therapy using quarterly progestin, *Obstet Gynecol* 83:693, 1994.
597. **Williams DB, Voigt BJ, Fu YS, Schoenfeld MJ, Judd HL**, Assessment of less than monthly progestin therapy in postmenopausal women given estrogen replacement, *Obstet Gynecol* 84:787, 1994.
598. **Boerriqter PJ, van de Weijer PHM, Baak JPA, Fox H, Haspels AA, Kenemans P**, Endometrial response in estrogen replacement therapy quarterly combined with a progestogen, *Maturitas* 24:63, 1996.
599. **Hirvonen E, Salmi T, Puolakka J, Heikkinen J, Granfors E, Hulkko S, Mäkäräinen L, Nummi S, Pekonen F, Rautio A-M, Sundström H, Telimaa S, Wilen-Rosenqvist G, Virkkunen A, Wahlström T**, Can progestin be limited to every third month only in postmenopausal women taking estrogen?, *Maturitas* 21:39, 1995.
600. **Jaakkola S, Lyytinen H, Pukkala E, Ylikorkala O**, Endometrial cancer in postmenopausal women using estradiol-progestin therapy, *Obstet Gynecol* 114:1197, 2009.
601. **Bjarnason K, Cerin Å, Lindgren R, Weber T**; for the **Scandinavian Long Cycle Study Group**, Adverse endometrial effects during long cycle hormone replacement therapy, *Maturitas* 32:151, 1999.
602. **Andersson J, Rybo G**, Levonorgestrel-releasing intrauterine device in the treatment of menorrhagia, *Br J Obstet Gynaecol* 97:690, 1990.
603. **Raudaskoski TH, Lahti EI, Kauppila AJ, Apaja-Sarkkinen MA, Laatikainen TJ**, Transdermal estrogen with a levonorgestrel-releasing intrauterine device for climacteric complaints: clinical and endometrial responses, *Am J Obstet Gynecol* 172:114, 1995.
604. **Wollter-Svensson LO, Stadberg E, Andersson K, Mattsson LA, Odling V, Persson I**, Intrauterine administration of levonorgestrel 5 and 10 microg/24 hours in perimenopausal hormone replacement therapy. A randomized clinical study during one year, *Acta Obstet Gynecol Scand* 76:449, 1997.
605. **Raudaskoski T, Tapanainen J, Tomas E, Luotola H, Pekonen F, Ronni-Sivula H, Timonen H, Riphagen F, Laatikainen T**, Intrauterine 10 microg and 20 microg levonorgestrel systems in postmenopausal women receiving oral oestrogen replacement therapy: clinical, endometrial and metabolic responses, *Br J Obstet Gynaecol* 109:136, 2002.
606. **Varila E, Wahlstrom T, Rauramo I**, A 5-year follow-up study on the use of a levonorgestrel intrauterine system in women receiving hormone replacement therapy, *Fertil Steril* 76:969, 2001.
607. **Wollter-Svensson L-O, Stadberg E, Andersson K, Mattsson L-Å, Odling V, Persson I**, Intrauterine administration of levonorgestrel in two low doses in HRT. A randomized clinical trial during one year: effects on lipid and lipoprotein metabolism, *Maturitas* 22:199, 1995.
608. **McMeekin DS, Burger RA, Manetta A, DiSaia P, Berman M**, Endometrioid adenocarcinoma of the ovary and its relationship to endometriosis, *Gynecol Oncol* 59:81, 1995.
609. **Sherwin BB, Gelfand MM**, The role of androgen in the maintenance of sexual functioning in oophorectomized women, *Psychosom Med* 49:397, 1987.
610. **Myers LS, Dixen J, Morrisette D, Carmichael M, Davidson JM**, Effects of estrogen, androgen, and

progesterin on sexual psychophysiology and behavior in postmenopausal women, *J Clin Endocrinol Metab* 70:1124, 1990.

611. **Shifren JL, Braunstein GD, Simon JA, Casson PR, Buster JE, Redmond GP, Burki RE, Ginsburg ES, Rosen RC, Leiblum SR, Caramelli KE, Mazer NA**, Transdermal testosterone treatment in women with impaired sexual function after oophorectomy, *N Engl J Med* 343:682, 2000.
612. **Hickok LR, Toomey C, Speroff L**, A comparison of esterified estrogens with and without methyltestosterone: effects on endometrial histology and serum lipoproteins in postmenopausal women, *Obstet Gynecol* 82:919, 1993.
613. **Watts NB, Notelovitz M, Timmons MC, Addison WA, Wiita B, Downey LJ**, Comparison of oral estrogens and estrogens plus androgens on bone mineral density, menopausal symptoms, and lipid-lipoprotein profiles in surgical menopause, *Obstet Gynecol* 85:529, 1995.
614. **Barrett-Connor E, Timmons C, Young R, Witta B**; for the **Estratest Working Group**, Interim safety analysis of a two-year study comparing oral estrogen-androgen and conjugated estrogens in surgically menopausal women, *J Womens Health* 5:593, 1996.
615. **Davis SR, McCloud P, Strauss BJG, Burger H**, Testosterone enhances estradiol's effects on postmenopausal bone density and sexuality, *Maturitas* 21:227, 1995.
616. **Bachmann GA, Timmons C, Abernethy WD**, Breakthrough bleeding patterns in two continuous combined estrogen/progesterone hormone replacement therapies, one of which included androgens, *J Womens Health* 5:205, 1996.
617. **Garnett T, Studd J, Watson N, Savvas M, Leather A**, The effects of plasma estradiol levels on increases in vertebral and femoral bone density following therapy with estradiol and estradiol with testosterone implants, *Obstet Gynecol* 79:968, 1992.
618. **Barrett-Connor E, Young RH, Notelovitz M, Sullivan J, Wiita B, Yang HM, Nolan J**, A two-year, double-blind comparison of estrogen-androgen and conjugated estrogens in surgically menopausal women. Effects on bone mineral density, symptoms and lipid profiles, *J Reprod Med* 44:1012, 1999.
619. **Urman B, Pride SM, Ho Yuen B**, Elevated serum testosterone, hirsutism, and virilism associated with combined androgen-estrogen hormone replacement therapy, *Obstet Gynecol* 77:595, 1991.
620. **Hameed A, Brothwood T, Bouloux P**, Delivery of testosterone replacement therapy, *Curr Opin Investig Drugs* 4:1213, 2003.
621. **Buckler HM, Robertson WR, Wu FCW**, Which androgen replacement therapy for women?, *J Clin Endocrinol Metab* 83:3920, 1998.
622. **Davis SR, van der Mooren MJ, van Lunsen RHW, Lopes P, Ribot C, Rees M, Moufarega A, Rodenberg C, Buch A, Purdie DM**, Efficacy and safety of a testosterone patch for the treatment of hypoactive sexual desire disorder in surgically menopausal women: a randomized, placebo-controlled trial, *Menopause* 13:387, 2006.
623. **Shifren JL, Davis SR, Moreau M, Waldbaum A, Bouchard C, DeRogatis L, Derzko C, Bearson P, Kakos N, O'Neill S, Levine S, Wekselman K, Buch A, Rodenberg C, Kroll R**, Testosterone patch for the treatment of hypoactive sexual desire disorder in naturally menopausal women: results from the INTIMATE NM1 Study, *Menopause* 13:770, 2007.
624. **Davis SR, Moreau M, Kroll R, Bouchard C, Panay N, Gass M, Braunstein G, Hirschberg AL, Rodenberg C, Pack S, Koch H, Moufarege A, Studd J**; for the **APHRODITE Study Team**, Testosterone for low libido in postmenopausal women not taking estrogen, *N Engl J Med* 359:2005, 2008.
625. **Tamimi RM, Hankinson SE, Chen WY, Rosner B, Colditz GA**, Combined estrogen and testosterone use and risk of breast cancer in postmenopausal women, *Arch Intern Med* 166:1483, 2006.
626. **Dimitrakakis C, Zhou J, Wang J, Belanger A, Labrie F, Cheng C, Powell D, Bondy C**, A physiologic role for testosterone in limiting estrogenic stimulation of the breast, *Menopause* 10:292, 2003.
627. **Hofling M, Hirschberg AL, Skoog L, Tani E, Hägerström T, von Schoultz B**, Testosterone inhibits estrogen/progesterone-induced breast cell proliferation in postmenopausal women, *Menopause* 14:183, 2007.
628. **Davis SR, Hirschberg AL, Wagner LK, Lodhi I, Von Schoultz B**, The effect of transdermal testosterone on mammographic density in postmenopausal women not receiving systemic estrogen therapy, *J Clin*

Endocrinol Metab 94:4907, 2009.

629. **Sterns EE, Zee B**, Mammographic density changes in perimenopausal and postmenopausal women: is effect of hormone replacement therapy predictable?, *Breast Cancer Res Treat* 59:125, 2000.
630. **Davis SR, Davison SL, Donath S, Bell RJ**, Circulating androgen levels and self-reported sexual function in women, *JAMA* 294:91, 2005.
631. **North American Menopause Society**. The role of testosterone therapy in postmenopausal women: position statement of The North American Menopause Society, *Menopause* 12(5):496, 2005; quiz 649.
632. **Fooladi E, Reuter SE, Bell RJ, Robinson PJ, Davis SR**, Pharmacokinetics of a transdermal testosterone cream in healthy postmenopausal women, *Menopause* 22(1):44, 2015.
633. **Huang G, Tang E, Aakil A, Anderson S, Jara H, Davda M, Stroh H, Trivison TG, Bhasin S, Basaria S**, Testosterone dose-response relationships with cardiovascular risk markers in androgen-deficient women: a randomized, placebo-controlled trial, *J Clin Endocrinol Metab* 99(7):E1287, 2014.
634. **Slyden SM, Crabbe L, Bae S, Potter HD, Azziz R, Parker CR Jr**, The effect of 17 $\beta$ -estradiol on adrenocortical sensitivity, responsiveness, and steroidogenesis in postmenopausal women, *J Clin Endocrinol Metab* 83:519, 1998.
635. **Baulieu EE, Thomas G, Legrain S, Lahlou N, Roger M, Debuire B, Faucounau V, Girard L, Hervy MP, Latour F, Leaud MC, Mokrane A, Pitti-Ferrandi H, Trivalle C, de Lacharriere O, Nouveau S, Rakoto-Arison B, Souberbielle JC, Raison J, Le Bouc Y, Raynaud A, Girerd X, Forette F**, Dehydroepiandrosterone (DHEA), DHEA sulfate, and aging: contribution of the DHEAge Study to a sociobiomedical issue, *Proc Natl Acad Sci U S A* 97:4279, 2000.
636. **Barnhart KT, Freeman E, Grisso JA, Rader DJ, Sammel M, Kapoor S, Nestler JE**, The effect of dehydroepiandrosterone supplementation to symptomatic perimenopausal women on serum endocrine profiles, lipid parameters, and health-related quality of life, *J Clin Endocrinol Metab* 84:3896, 1999.
637. **Hackbert L, Heiman JR**, Acute dehydroepiandrosterone (DHEA) effects on sexual arousal in postmenopausal women, *J Womens Health Gend Based Med* 11:155, 2002.
638. **Johannes CB, Stellato RK, Feldman HA, Longcope C, McKinlay JB**, Relation of dehydroepiandrosterone and dehydroepiandrosterone sulfate with cardiovascular disease risk factors in women: longitudinal results from the Massachusetts Women's Health Study, *J Clin Epidemiol* 52:95, 1999.
639. **Aarlt W, Haas J, Callies F, Reincke M, Hubler D, Oettel M, Ernst M, Schulte HM, Allolio B**, Biotransformation of oral dehydroepiandrosterone in elderly men: significant increase in circulating estrogens, *J Clin Endocrinol Metab* 84:2170, 1999.
640. **Morales A, Nolan J, Nelson J, Yen SSC**, Effects of replacement dose of dehydroepiandrosterone in men and women of advancing age, *J Clin Endocrinol Metab* 78:1360, 1994.
641. **Casson PR, Santoro N, Elkind-Hirsch KE, Carson SA, Hornsby PJ, Abraham G, Buster J**, Postmenopausal dehydroepiandrosterone (DHEA) administration increases insulin-like growth factor-I (IGF-I) and decreases high density lipoprotein (HDL): a six month trial, *Fertil Steril* 70:107, 1998.
642. **Thompson RD, Carlson M**, Liquid chromatographic determination of dehydroepiandrosterone (DHEA) in dietary supplement products, *J AOAC Int* 83:847, 2000.
643. **Labrie F, Archer D, Bouchard C, Fortier M, Cusan L, Gomez JL, Girard G, Baron M, Ayotte N, Moreau M, Dubé R, Côté I, Labrie C, Lavoie L, Berger L, Gilbert L, Martel C, Baiser J**, Intravaginal dehydroepiandrosterone (Prasterone), the physiological and a highly efficient treatment of vaginal atrophy, *Menopause* 16:907, 2009.
644. **Labrie F, Archer D, Bouchard C, Fortier M, Cusan L, Gomez JL, Girard G, Baron M, Ayotte N, Moreau M, Dubé R, Côté I, Labrie C, Lavoie L, Bérubé R, Bélanger P, Berger L, Gilbert L, Martel C, Baiser J**, Serum steroid levels during 12-week intravaginal dehydroepiandrosterone administration, *Menopause* 16:897, 2009.
645. **Labrie F, Cusan L, Gomez JL, Côté I, Bérubé R, Bélanger P, Martel C, Labrie C**, Effect of intravaginal DHEA on serum DHEA and eleven of its metabolites in postmenopausal women, *J Steroid Biochem Mol Biol* 111:178, 2009.
646. **Labrie F, Archer D, Bouchard C, Fortier M, Cusan L, Gomez JL, Girard G, Baron M, Ayotte N**,

- Moreau M, Dubé R, Côte ML, Labrie C, Lavoie L, Berger L, Gilbert L, Martel C, Balsler J, Effect of intravaginal dehydroepiandrosterone (Prasterone) on libido and sexual dysfunction in postmenopausal women, *Menopause* 16:923, 2009.
647. Archer DF, Labrie F, Montesino M, Martel C, Comparison of intravaginal 6.5mg (0.50%) prasterone, 0.3mg conjugated estrogens and 10µg estradiol on symptoms of vulvovaginal atrophy, *J Steroid Biochem Mol Biol* 174:1, 2017.
648. Labrie F, Archer DF, Koltun W, Vachon A, Young D, Frenette L, Portman D, Montesino M, Côté I, Parent J, Lavoie L, Beauregard A, Martel C, Vaillancourt M, Balsler J, Moyneur É; VVA Prasterone Research Group, Efficacy of intravaginal dehydroepiandrosterone (DHEA) on moderate to severe dyspareunia and vaginal dryness, symptoms of vulvovaginal atrophy, and of the genitourinary syndrome of menopause, *Menopause* 23(3):243, 2016.
649. Draper MW, Flowers DE, Huster WJ, Neild JA, Harper KD, Arnaud C, A controlled trial of raloxifene (LY139481) HCl: impact on bone turnover and serum lipid profile in healthy postmenopausal women, *J Bone Miner Res* 11:835, 1996.
650. Boss SM, Huster WJ, Neild JA, Glant MD, Eisenhut CC, Draper MW, Effects of raloxifene hydrochloride on the endometrium of postmenopausal women, *Am J Obstet Gynecol* 177:1458, 1997.
651. Delmas PD, Bjarnason NH, Mitlak BH, Ravoux A-C, Shah AS, Huster WJ, Draper M, Christiansen C, Effects of raloxifene on bone mineral density, serum cholesterol concentrations, and uterine endometrium in postmenopausal women, *N Engl J Med* 337:1641, 1997.
652. Walsh BW, Kuller LH, Wild RA, Paul S, Farmer M, Lawrence JB, Shah AS, Anderson PW, Effects of raloxifene on serum lipids and coagulation factors in healthy postmenopausal women, *JAMA* 279:1445, 1998.
653. Delmas PD, Ensrud KE, Adachi JD, Harper KD, Sarkar S, Gennari C, Reginster JY, Pols HA, Recker RR, Harris ST, Wu W, Genant HK, Black DM, Eastell R; Multiple Outcomes of Raloxifene Evaluation Investigators, Efficacy of raloxifene on vertebral fracture risk reduction in postmenopausal women with osteoporosis: four-year results from a randomized clinical trial, *J Clin Endocrinol Metab* 87:3609, 2002.
654. Siris ES, Harris ST, Eastell R, Zanchetta JR, Goemaere S, Diez-Perez A, Stock JL, Song J, Qu Y, Kulkarni PM, Siddhanti SR, Wong M, Cummings SR; for the Continuing Outcomes Relevant to Evista (CORE) Investigators, Skeletal effects of raloxifene after 8 years: results from the Continuing Outcomes Relevant to Evista (CORE) Study, *J Bone Miner Res* 20:1514, 2005.
655. Cummings SR, Eckert S, Krueger KA, Grady D, Powles TJ, Cauley JA, Norton L, Nickelsen T, Bjarnason NH, Morrow M, Lippman ME, Black D, Glusman JE, Costa A, Jordan VC, The effect of raloxifene on risk of breast cancer in postmenopausal women. Results from the MORE randomized trial, *JAMA* 281:2189, 1999.
656. Yaffe K, Krueger K, Sarkar S, Grady D, Barrett-Connor E, Cox DA, Nickelsen T; for the Multiple Outcomes of Raloxifene Evaluation Investigators, Cognitive function in postmenopausal women treated with raloxifene, *N Engl J Med* 344:1207, 2001.
657. Martino S, Cauley JA, Barrett-Connor E, Powles TJ, Mershon J, Disch D, Secrest RJ, Cummings SR; for the CORE Investigators, Continuing outcomes relevant to Evista: breast cancer incidence in postmenopausal osteoporotic women in a randomized trial of raloxifene, *J Natl Cancer Inst* 96:1651, 2004.
658. Vogel VG, Costantino JP, Wickerham DL, Cronin WM, Cecchini RS, Atkins JN, Bevers TB, Fehrenbacher L, Pajon ER Jr, Wade JL III, Robidoux A, Margolese RG, James J, Lippman SM, Runowicz CD, Ganz PA, Reis SE, McCaskill-Stevens W, Ford LG, Jordan VC, Wolmark N; National Surgical Adjuvant Breast and Bowel Project (NSABP), Effects of tamoxifen vs raloxifene on the risk of developing invasive breast cancer and other disease outcomes: the NSABP Study of Tamoxifen and Raloxifene (STAR) P-2 trial, *JAMA* 295:2727, 2006.
659. Fisher B, Costantino JP, Wickerham DL, Cecchini RS, Cronin WM, Robidoux A, Bevers TB, Kavanah MT, Atkins JN, Margolese RG, Runowicz CD, James JM, Ford LG, Wolmark N, Tamoxifen for the prevention of breast cancer: current status of the National Surgical Adjuvant Breast and Bowel Project P-1 Study, *J Natl Cancer Inst* 97:1652, 2005.

660. **Fisher B, Costantino JP, Wickerham DL, Redmond CK, Kavanah M, Cronin WM, Vogel V, Robidoux A, Dimitrov N, Atkins J, Daly M, Wieand S, Tan-Chiu E, Ford L, Wolmark N; other National Surgical Adjuvant Breast and Bowel Project Investigators**, Tamoxifen for prevention of breast cancer: report of the National Surgical Adjuvant Breast and Bowel Project P-1 Study, *J Natl Cancer Inst* 90:1371, 1998.
661. **Clarkson TB, Anthony MS, Jerome CP**, Lack of effect of raloxifene on coronary artery atherosclerosis of postmenopausal monkeys, *J Clin Endocrinol Metab* 83:721, 1998.
662. **Barrett-Connor E, Mosca L, Collins P, Geiger MJ, Grady D, Kornitzer M, McNabb MA, Wenger NK; Raloxifene Use for the Heart (RUTH) Trial Investigators**, Effects of raloxifene on cardiovascular events and breast cancer in postmenopausal women, *N Engl J Med* 355:125, 2006.
663. **Collins P, Mosca L, Geiger MJ, Grady D, Kornitzer M, Amewou-Atisso MGE, Effron MB, Dowsett SA, Barrett-Connor E, Wenger NK**, Effects of the selective estrogen receptor modulator raloxifene on coronary outcomes in the Raloxifene Use for the Heart Trial. Results of subgroup analyses by age and other factors, *Circulation* 119:922, 2009.
664. **Gennari L, Merlotti D, Valleggi F, Nuti R**, Ospemifene use in postmenopausal women, *Expert Opin Investig Drugs* 18:839, 2009.
665. **Simon JA, Altomare C, Cort S, Jiang W, Pinkerton JV**, Overall safety of ospemifene in postmenopausal women from placebo-controlled phase 2 and 3 trials, *J Womens Health (Larchmt)* 27(1):14, 2018.
666. **Schiavi MC, Sciuga V, Giannini A, Vena F, D'oria O, Prata G, Di Tucci C, Savone D, Aleksa N, Capone C, Di Mascio D, Meggiorini ML, Monti M, Zullo MA, Muzii L, Benedetti Panici P**, Overactive bladder syndrome treatment with ospemifene in menopausal patients with vulvovaginal atrophy: improvement of sexuality? *Gynecol Endocrinol* 34(8):666, 2018.
667. **Berrodin TJ, Chang KCN, Komm B, Freedman LP, Nagpal S**, Differential biochemical and cellular actions of Premarin estrogens: distinct pharmacology of bazedoxifene-conjugated estrogens combination, *Mol Endocrinol* 23:74, 2009.
668. **Pinkerton JV, Archer DA, Utian WH, Menegoci JC, Levine AB, Chines AA, Constantine GD**, Bazedoxifene effects on the reproductive tract in postmenopausal women at risk for osteoporosis, *Menopause* 16:1102, 2009.
669. **Archer DA, Pinkerton JV, Utian WH, Menegoci JC, de Villiers TJ, Kin Yen C, Levine AB, Chines AA, Constantine GD**, Bazedoxifene, a selective estrogen receptor modulator: effects on the endometrium, ovaries, and breast from a randomized controlled trial in osteoporotic postmenopausal women, *Menopause* 16:1109, 2009.
670. **Silverman SL, Christiansen C, Genant HK, Vukicevic S, Zanchetta JR, de Villiers TJ, Constantine GD, Chines AA**, Efficacy of bazedoxifene in reducing new vertebral fracture risk in postmenopausal women with osteoporosis: results from a 3-year, randomized, placebo-, and active-controlled clinical trial, *J Bone Miner Res* 23:1923, 2008.
671. **Kanis JA, Johansson H, Oden A, McCloskey EV**, Bazedoxifene reduces vertebral and clinical fractures in postmenopausal women at high risk assessed with FRAX, *Bone* 44(6):1049, 2009. doi: 10.1016/j.bone.2009.02.014.
672. **Harvey JA, Hollm MK, Ranganath R, Guse PA, Trott EA, Helzner E**, The effects of bazedoxifene on mammographic breast density in postmenopausal women with osteoporosis, *Menopause* 16:1193, 2009.
673. **Pinkerton JV, Harvey JA, Pan K, Thompson JR, Ryan KA, Chines AA, Mirkin S, Archer DF; SMART-5 Investigators**, Breast effects of bazedoxifene-conjugated estrogens: a randomized controlled trial, *Obstet Gynecol* 121(5):959, 2013.
674. **Lobo RA, Pinkerton JV, Gass ML, Dorin MH, Ronkin S, Pickar JH, Constantine G**, Evaluation of bazedoxifene/conjugated estrogens for the treatment of menopausal symptoms and effects on metabolic parameters and overall safety profile, *Fertil Steril* 92:1025, 2009.
675. **Lindsay R, Gallagher JC, Kagan R, Pickar JH, Constantine G**, Efficacy of tissue-selective estrogen complex of bazedoxifene/conjugated estrogens for osteoporosis prevention in at-risk postmenopausal women, *Fertil Steril* 92:1045, 2009.

676. **Pinkerton JV, Utian WH, Constantine GD, Olivier S, Pickar JH**, Relief of vasomotor symptoms with the tissue-selective estrogen complex containing bazedoxifene/conjugated estrogens: a randomized, controlled trial, *Menopause* 16:1116, 2009.
677. **Pinkerton JV, Pickar JH, Racketta J, Mirkin S**, Bazedoxifene/conjugated estrogens for menopausal symptom treatment and osteoporosis prevention, *Climacteric* 15(5):411, 2012.
678. **Pickar JH, Yeh IT, Bachmann G, Speroff L**, Endometrial effects of a tissue selective estrogen complex containing bazedoxifene/conjugated estrogens as a menopausal therapy, *Fertil Steril* 92:1018, 2009.
679. **Archer DF, Lewis V, Carr BR, Olivier S, Pickar JH**, Bazedoxifene/conjugated estrogens (BZA/CE): incidence of uterine bleeding in postmenopausal women, *Fertil Steril* 92:1039, 2009.
680. **Modelska K, Cummings S**, Tibolone for postmenopausal women: systematic review of randomized trials, *J Clin Endocrinol Metab* 87(1):16, 2002.
681. **Formoso G, Perrone E, Maltoni S, Balduzzi S, D'Amico R, Bassi C, Basevi V, Marata AM, Magrini N, Maestri E**, Short and long term effects of tibolone in postmenopausal women, *Cochrane Database Syst Rev* (2):Cd008536, 2012.
682. **Kloosterboer HJ**, Tibolone: a steroid with a tissue-specific mode of action, *J Steroid Biochem* 76:231, 2001.
683. **de Gooyer ME, Deckers GH, Schoonen WGEJ, Verheul HAM, Kloosterboer HJ**, Receptor profiling and endocrine interactions of tibolone, *Steroids* 68:21, 2003.
684. **Timmer CJ, Huisman JAM**, Effect of a standardized meal on the bioavailability of a single oral dose of tibolone 2.5 mg in healthy postmenopausal women, *Pharmacotherapy* 22:310, 2002.
685. **Vos RME, Krebbers SFM, Verhoeven CHJ, Delbressine LPC**, The in vivo human metabolism of tibolone, *Drug Metab Dispos* 30:106, 2002.
686. **Timmer CJ, Houwing NS**, Dose proportionality of three different doses of tibolone, *Pharmacotherapy* 22:6, 2002.
687. **Markiewicz L, Gurpide E**, In vitro evaluation of estrogenic, estrogen antagonistic and progestagenic effects of a steroidal drug (Org OD-14) and its metabolites on human endometrium, *J Steroid Biochem* 35:535, 1990.
688. **Tang B, Markiewicz L, Kloosterboer HJ, Gurpide E**, Human endometrial 3 beta-hydroxysteroid dehydrogenase/isomerase can locally reduce intrinsic estrogenic/progestagenic activity ratios of a steroidal drug (Org OD 14), *J Steroid Biochem Mol Biol* 45:345, 1993.
689. **Punnonen R, Liukko P, Cortes-Prieto J, Eydam F, Milojevic S, Trevoux R, Chryssikopoulos E, Franchi F, Luisi M, Kicovic PM**, Multicentre study of effects of Org OD14 on endometrium, vaginal cytology and cervical mucus in postmenopausal and oophorectomized women, *Maturitas* 5:281, 1984.
690. **Genazzani AR, Benedek Jaszmann L, Hart DM, Andolsek L, Kicovic PM, Tax L**, Org OD14 and the endometrium, *Maturitas* 13:243, 1991.
691. **Trevoux R, Dieulangard P, Blum A**, Efficacy and safety of Org OD 14 in the treatment of climacteric complaints, *Maturitas* 5:89, 1983.
692. **Volpe A, Facchinetti F, Grasso A, Petraglia F, Campanini D, Genazzani AR**, Benefits and risks of different hormonal replacement therapies in postmenopausal women, *Maturitas* 8:327, 1986.
693. **Siseles NO, Halperin H, Benencia HJ, Berg G, Pilnik S, Mesch V, Arrighi B, Wikinski RW**, A comparative study of two hormone replacement therapy regimens on safety and efficacy variables, *Maturitas* 21:201, 1995.
694. **Nathorst-Böös J, Hammar M**, Effect on sexual life—a comparison between tibolone and a continuous estradiol-norethisterone acetate regimen, *Maturitas* 26:15, 1997.
695. **Hammar M, Christau S, Nathorst-Böös J, Rud T, Garre K**, A double-blind, randomised trial comparing the effects of tibolone and continuous combined hormone replacement therapy in postmenopausal women with menopausal symptoms, *Br J Obstet Gynaecol* 105:904, 1998.
696. **Al-Azzawi F, Wahab M, Habiba M, Akkad A, Mason T**, Continuous combined hormone replacement therapy compared with tibolone, *Obstet Gynecol* 93:258, 1999.
697. **Kökü A, Centinkaya MB, Yanik F, Alper T, Malatydliloglu E**, The comparison of effects of tibolone and conjugated estrogen-medroxyprogesterone acetate therapy on sexual performance in postmenopausal women, *Maturitas* 36:75, 2000.



698. **Landgren MB, Coelingh Benink HJT, Helmond FA, Engelen S**, Dose-response analysis of effects of tibolone on climacteric symptoms, *Br J Obstet Gynaecol* 109:1109, 2002.
699. **Taskin O, Yalcinoglu AI, Kucuk S, Uryan I, Buhur A, Burak F**, Effectiveness of tibolone on hypoestrogenic symptoms induced by goserelin treatment in patients with endometriosis, *Fertil Steril* 67:40, 1997.
700. **Crona N, Silfverstolpe G, Samsioe G**, A double-blind cross-over study on the effects of Org OD 14 compared to estradiol valerate and placebo on lipid and carbohydrate metabolism in oophorectomized women, *Acta Endocrinol* 102:451, 1983.
701. **Rymer J, Chapman MG, Fogelman I, Wilson POG**, A study of the effect of tibolone on the vagina in postmenopausal women, *Maturitas* 18:127, 1994.
702. **Botsis D, Kassanos D, Kalogirous D, Antonious G, Vitoratos N, Karakitsos P**, Vaginal ultrasound of the endometrium in postmenopausal women with symptoms of urogenital atrophy on low-dose estrogen or tibolone treatment: a comparison, *Maturitas* 26:57, 1997.
703. **Laan E, van Lunsen RHW, Everaerd W**, The effects of tibolone on vaginal blood flow, sexual desire and arousability in postmenopausal women, *Climacteric* 4:28, 2001.
704. **Mendoza N, Suárez AM, Álamo F, Bartual E, Vergara F, Herruzo A**, Lipid effects, effectiveness and acceptability of tibolone versus transdermic 17 $\beta$ -estradiol for hormonal replacement therapy in women with surgical menopause, *Maturitas* 37:37, 2000.
705. **Castelo-Branco C, Vicente JJ, Figueras F, Sanjuan A, Martinez de Osaba MJ, Casals E, Pons F, Balasch J, Vanrell JA**, Comparative effects of estrogens plus androgens and tibolone on bone, lipid pattern and sexuality in postmenopausal women, *Maturitas* 34:161, 2000.
706. **Huber J, Palacios S, Berglund L, Hänggi W, Sathanandan SM, Christau S, Helmond F**, Effects of tibolone and continuous combined hormone replacement therapy on bleeding rates, quality of life and tolerability in postmenopausal women, *Br J Obstet Gynaecol* 109:886, 2002.
707. **Egarter C, Topcuoglu AM, Vogl S, Sator M**, Hormone replacement therapy with tibolone: effects on sexual functioning in postmenopausal women, *Acta Obstet Gynecol Scand* 81:649, 2002.
708. **Palacios S, Menendez C, Jurado R, Castano JC, Vargas JC**, Changes in sex behaviour after menopause: effects of tibolone, *Maturitas* 22:155, 1995.
709. **Nijland EA, Weijmar Schultz WC, Nathorst-Böös J, Helmond FA, Van Lunsen RHW, Palacios S, Norman RJ, Mulder RJ, Davis SR; LISA Study Investigators Group**, Tibolone and transdermal E2/NETA for the treatment of sexual dysfunction in naturally menopausal women: results of a randomized active-controlled trial, *J Sex Med* 5:646, 2008.
710. **Dören M, Rubig A, Coelingh Benink HJT, Holzgreve W**, Differential effects on the androgen status of postmenopausal women treated with tibolone and continuous combined estradiol and norethindrone acetate replacement therapy, *Fertil Steril* 75:554, 2001.
711. **Fluck E, File SE, Rymer J**, Cognitive effects of 10 years of hormone-replacement therapy with tibolone, *J Clin Psychopharmacol* 22:62, 2002.
712. **Bukulmez O, Al A, Gurdal H, Yarali H, Ulug B, Gurgan T**, Short-term effects of three continuous hormone replacement therapy regimens on platelet tritiated imipramine binding and mood scores: a prospective randomized trial, *Fertil Steril* 75:737, 2001.
713. **Clarkson TB, Anthony M, Wagner JD**, A comparison of tibolone and conjugated equine estrogens effects on coronary artery atherosclerosis and bone density of postmenopausal monkeys, *J Clin Endocrinol Metab* 86:5396, 2001.
714. **Clarkson TB, Anthony MS, Mikkola TS, St. Clair RW**, Comparison of tibolone and conjugated equine estrogens effects on carotid artery atherosclerosis of postmenopausal monkeys, *Stroke* 33:2700, 2002.
715. **Fielding CJ, Fielding PE**, Molecular physiology of reverse cholesterol transport, *J Lipid Res* 36:211, 1995.
716. **Pajunen P, Syväne M, Castro G, Nieminen MS, Taskinen MR**, Cholesterol efflux capacity in vitro predicts the severity and extent of coronary artery disease in patients with and without Type 2 diabetes, *Scand Cardiovasc J* 35:96, 2001.
717. **Mikkola TS, Anthony M, Clarkson TB, St. Clair RW**, Serum cholesterol efflux in postmenopausal

monkeys treated with tibolone or conjugated estrogens, *Metabolism* 51:523, 2002.

718. **Rymer J, Crook D, Sidhu M, Chapman M, Stevenson JC**, Effects of tibolone on serum concentrations of lipoprotein(a) in postmenopausal women, *Acta Endocrinol* 128:259, 1993.
719. **Milner MH, Sinnott MM, Cooke TM, Kelly A, McGill T, Harrison RF**, A 2-year study of lipid and lipoprotein changes in postmenopausal women with tibolone and estrogen-progestin, *Obstet Gynecol* 87:593, 1996.
720. **Cagnacci A, Mallus E, Tuveri F, Cirillo R, Setteneri AM, Melis GB**, Effects of tibolone on glucose and lipid metabolism in postmenopausal women, *J Clin Endocrinol Metab* 82:251, 1997.
721. **Lloyd G, McGing E, Cooper A, Patel N, Lumb PJ, Wierzbicki AS, Jackson G**, A randomised placebo controlled trial of the effects of tibolone on blood pressure and lipids in hypertensive women, *J Hum Hypertens* 14:99, 2000.
722. **Ginsburg J, Prelevic GM**, Antiatherosclerotic effects of tibolone, *Menopause* 8:79, 2001.
723. **Gallagher JC, Baylink DJ, Freeman R, McClung M**, Prevention of bone loss with tibolone in postmenopausal women: results of two randomized double-blind, placebo-controlled, dose-finding studies, *J Clin Endocrinol Metab* 86:4717, 2001.
724. **Barnes JF, Farish E, Rankin M, Hart DM**, A comparison of the effects of two continuous HRT regimens on cardiovascular risk factors, *Atherosclerosis* 160:185, 2002.
725. **Haenggi W, Bersinger NA, Mueller MD, Bikhäuser MH**, Decrease of serum endothelin levels with postmenopausal hormone replacement therapy or tibolone, *Gynecol Endocrinol* 13:202, 1999.
726. **Farish E, Barnes JF, Rolton HA, Spowart K, Fletcher CD, Hart DM**, Effects of tibolone on lipoprotein(a) and HDL subfractions, *Maturitas* 20:215, 1994.
727. **Lloyd GWL, Patel NR, McGing EA, Cooper AF, Kamalvand K, Jackson G**, Acute effects of hormone replacement with tibolone on myocardial ischaemia in women with angina, *Int J Clin Pract* 52:155, 1998.
728. **von Eckardstein A, Schmidem K, Hövels A, Gülbahce E, Schuler-Lüttmann S, Elbers J, Helmond F, Bennink HJ, Assmann G**, Lowering of HDL cholesterol in post-menopausal women by tibolone is not associated with changes in cholesterol efflux capacity or paraoxonase activity, *Atherosclerosis* 159:433, 2001.
729. **Castelo-Branco C, Casals E, Figueras F, Sanjuan A, Vicente JJ, Balasch J, Vanrell JA**, Two-year prospective and comparative study on the effects of tibolone on lipid pattern, behavior of apolipoproteins A1 and B, *Menopause* 6:92, 1999.
730. **Bjarnason NH, Bjarnason K, Haarbo J, Coelingh Bennink HJT, Christiansen C**, Tibolone: influence on markers of cardiovascular disease, *J Clin Endocrinol Metab* 82:1752, 1997.
731. **Kloosterboer HJ, Benedek Jaszmann L, Kicovic PM**, Long-term effects of OrgOD14 on lipid metabolism in post-menopausal women, *Maturitas* 12:37, 1990.
732. **Pan H-A, Wang S-T, Chen C-H, Pai M-C, Wu M-H, Huang K-E**, Flow resistance in carotid and middle cerebral arteries in postmenopausal women: a comparative study of tibolone and continuous combined hormone replacement therapy, *Climacteric* 5:259, 2002.
733. **Cetinkaya MB, Alper T, Kökcü A, Yanik FF, Malatyalioglu E**, Tibolone versus four estrogen replacement therapy protocols and plasma lipid levels in postmenopausal women, *Int J Gynaecol Obstet* 79:17, 2002.
734. **von Eckardstein A, Nofer JR, Assmann G**, High density lipoproteins and atherosclerosis. Role of cholesterol efflux and reverse cholesterol transport, *Arterioscler Thromb Vasc Biol* 21:13, 2001.
735. **von Eckardstein A, Crook D, Elbers J, Ragoobir J, Ezeh B, Helmonds F, Miller N, Dieplinger H, Coelingh Benink H, Assmann A**, Tibolone lowers high density lipoprotein cholesterol by increasing hepatic lipase activity but does not impair cholesterol efflux, *Clin Endocrinol* 58:49, 2003.
736. **Morris EP, Denton ERE, Robinson JG, MacDonald LM, Rymer JM**, High resolution ultrasound assessment of the carotid artery: its relevance in postmenopausal women and the effects of tibolone on carotid artery ultrastructure, *Climacteric* 2:13, 1999.
737. **de Kleijn MJ, Wilink HW, Bots ML, Bak AA, van der Schouw YT, Planellas J, Engelen S, Banga JD, Grobbee DE**, Hormone replacement therapy and endothelial function. Results of a randomized controlled trial in healthy postmenopausal women, *Atherosclerosis* 159:357, 2001.
738. **Ceballos C, Ribes C, Amado JA, de Mier I, de Rozas LS, Berrazueta JR**, Venous endothelial function in

postmenopausal women after six months of tibolone therapy, *Maturitas* 39:63, 2001.

739. **Manzella D, Fornaro F, Carbonella M, Picardi C, Paolisso G, Colacurci N**, Effect of tibolone administration on heart rate variability and free fatty acid levels in postmenopausal women, *Fertil Steril* 78:1005, 2002.
740. **Simoncini T, Genazzani AR**, Tibolone inhibits leukocyte adhesion molecule expression in human endothelial cells, *Mol Cell Endocrinol* 162:87, 2000.
741. **Bots ML, Evans GW, Riley W, McBride KH, Paskett ED, Helmond FA, Grobbee DE; for the OPAL Investigators**, The effect of tibolone and continuous combined conjugated equine oestrogens plus medroxyprogesterone acetate on progression of carotid intima-media thickness, *Eur Heart J* 27:746, 2006.
742. **Renoux C, Dell'Aniello S, Suissa S**, Hormone replacement therapy and the risk of venous thromboembolism: population-based study, *J Thromb Haemost* 8:979, 2010.
743. **De Beer F, Smelt AHM, Van Vark LC, Hoogerbrugge N, Havekes LM, Gevers Leuven JA**, The effect of tibolone on the lipoprotein profile of postmenopausal women with type III hyperlipoproteinemia, *J Int Med* 251:148, 2002.
744. **Prelevic GM, Beljic T, Balint-Peric L, Ginsburg J**, Metabolic effects of tibolone in postmenopausal women with non-insulin dependent diabetes mellitus, *Maturitas* 28:271, 1998.
745. **Wiegatz I, Starflinger F, Tetzloff W, Leifels-Fischer B, Helmond FA, Dericks-Tan JSE, Kuhl H**, Effect of tibolone compared with sequential hormone replacement therapy on carbohydrate metabolism in postmenopausal women, *Maturitas* 41:133, 2002.
746. **Ginsburg J, Prelevic G, Butler D, Okolo S**, Clinical experience with tibolone (Livial) over 8 years, *Maturitas* 21:71, 1995.
747. **Meuwissen J, Wiegerinck M, Haverkorn M**, Regression on endometrial thickness in combination with reduced withdrawal bleeding as a progestational effect of tibolone in postmenopausal women on oestrogen replacement therapy, *Maturitas* 21:121, 1995.
748. **Egarter C, Sator M, Berghammer P, Huber J**, Efficacy, tolerability, and rare side effects of tibolone treatment in postmenopausal women, *Int J Gynaecol Obstet* 64:281, 1999.
749. **Völker W, Coelingh Bennink HJT, Helmond FA**, Effects of tibolone on the endometrium, *Climacteric* 4:203, 2001.
750. **Ginsburg J, Prelevic GM**, Cause of vaginal bleeding in postmenopausal women taking tibolone, *Maturitas* 24:1, 1996.
751. **Archer DF, Henddrix S, Gallagher JC, Rymer J, Skouby S, Ferenczy A, den Hollander W, Stathopoulos V, Helmond FA; for the Tibolone Histology of the Endometrium and Breast Endpoints (THEBES) Study Group**, Endometrial effects of tibolone, *J Clin Endocrinol Metab* 92:911, 2007.
752. **Wu M-H, Pan H-A, Wang S-T, Hsu C-C, Chang F-M, Huang K-E**, Quality of life and sexuality changes in postmenopausal women receiving tibolone therapy, *Climacteric* 4:314, 2001.
753. **Nijland EA, Nathorst-Böös J, Palacios S, van de Weijer PW, Davis S, Stathopoulos VM, Birkhäuser MH, von Mauw E, Mulder RJ, Schultz WC; LISA Study Investigators Group**, Improved bleeding profile and tolerability of tibolone versus transdermal E2/NETA treatment in postmenopausal women with female sexual dysfunction, *Climacteric* 12:114, 2009.
754. **Rymer J, Fogelman I, Champman MG**, The incidence of vaginal bleeding with tibolone treatment, *Br J Obstet Gynaecol* 101:53, 1994.
755. **Berning B, van Kuijk C, Coelingh Benink HJT, Fauser BCJM**, Absent correlation between vaginal bleeding and oestradiol levels or endometrial morphology during tibolone use in early postmenopausal women, *Maturitas* 35:81, 2000.
756. **Hanggi W, Lippuner K, Riesen W, Jaeger P, Birkauser MH**, Long-term influence of different postmenopausal hormone replacement regimens on serum lipids and lipoprotein(a): a randomised trial, *Br J Obstet Gynaecol* 104:708, 1997.
757. **Fedele L, Bianchi S, Raffaelli R, Zanconato G**, A randomized study of the effects of tibolone and transdermal estrogen replacement therapy in postmenopausal women with uterine myomas, *Eur J Obstet Gynecol Reprod Biol* 88:91, 2000.

758. **Gregoriou O, Konidaris S, Botsis D, Papadias C, Makrakis E, Creatsas G**, Long term effects of tibolone on postmenopausal women with uterine myomas, *Maturitas* 40:95, 2001.
759. **Simsek T, Karakus C, Trak B**, Impact of different hormone replacement therapy regimens on the size of myoma uteri in postmenopausal period. Tibolone versus transdermal hormonal replacement system, *Maturitas* 42:243, 2002.
760. **Palomba S, Affinito P, Tommaselli GA, Nappi C**, A clinical trial of the effects of tibolone administered with gonadotropin-releasing hormone analogues for the treatment of uterine leiomyomata, *Fertil Steril* 70:111, 1998.
761. **Santner SJ, Feil PD, Santen RJ**, In situ estrogen production via estrone sulfatase pathway in breast tumors: relative importance versus aromatase pathway, *J Clin Endocrinol Metab* 59:29, 1984.
762. **Chetrite GS, Cortes-Prieto J, Philippe JC, Wright F, Pasqualini JR**, Comparison of estrogen concentrations, estrone sulfatase and aromatase activities in normal, and in cancerous, human breast tissues, *J Steroid Biochem Mol Biol* 72:23, 2000.
763. **Chetrite G, Kloosterboer HJ, Pasqualini JR**, Effect of tibolone (Org OD14) and its metabolites on estrone sulphatase activity in MCF-7 and T-47D mammary cancer cells, *Anticancer Res* 17:135, 1997.
764. **Chetrite GS, Kloosterboer HJ, Philippe JC, Pasqualini JR**, Effects of Org OD14 (Livial) and its metabolites on 17-beta-hydroxysteroid dehydrogenase activity in hormone-dependent MCF-7 and T-47D breast cancer cells, *Anticancer Res* 19:261, 1999.
765. **van de Ven J, Donker GH, Spsrong M, Blankenstein MA, Thijssen JHH**, Effect of tibolone (Org OD14) and its metabolites on aromatase and estrone sulfatase activity in human breast adipose stromal cells and in MCF-7 and T47D breast cancer cells, *J Steroid Biochem Mol Biol* 81:237, 2002.
766. **Purohit A, Malini B, Hooymans C, Newman SP**, Inhibition of oestrone sulphatase activity by tibolone and its metabolites, *Horm Metab Res* 1:1, 2002.
767. **Chetrite GS, Kloosterboer HJ, Philippe JC, Pasqualini JR**, Effect of Org OD14 (Livial) and its metabolites on human estrogen sulphotransferase activity in the hormone-dependent MCF-7 and T-47D, and hormone-independent MDA-MB-231, breast cancer cell lines, *Anticancer Res* 19:269, 1999.
768. **Kloosterboer HJ**, Endocrine prevention of breast: any role for tibolone?, *Eur J Cancer Suppl* 6:S24, 2002.
769. **Gompel A, Siromachkova M, Lombet A, Kloosterboer HJ, Rostene W**, Tibolone actions on normal and breast cancer cells, *Eur J Cancer* 36:76, 2000.
770. **de Gooyer ME, Overklift Vaupel Kleyn GT, Smits KC, Ederveen AGH, Verheul HAM, Kloosterboer HJ**, Tibolone: a compound with tissue specific inhibitory effects on sulfatase, *Mol Cell Endocrinol* 183:55, 2001.
771. **Valdivia I, Ortega D**, Mammographic density in postmenopausal women treated with tibolone, estriol or conventional hormone replacement therapy, *Clin Drug Invest* 20:101, 2000.
772. **Colacurci N, Fornaro F, De Franciscis P, Palermo M, del Vecchio W**, Effects of different types of hormone replacement therapy on mammographic density, *Maturitas* 40:159, 2001.
773. **Sendag F, Terek MC, Özsener S, Öztekin K, Bilgin O, Bilgen I, Memis A**, Mammographic density changes during different postmenopausal hormone replacement therapies, *Fertil Steril* 76:445, 2001.
774. **Lundström E, Christow A, Kersemaekers W, Svane G, Azavedo E, Söderqvist G, Mol-Arts M, Barkfeldt J, von Scholutz B**, Effects of tibolone and continuous combined hormone replacement therapy on mammographic breast density, *Am J Obstet Gynecol* 186:717, 2002.
775. **Egarter C, Eppel W, Vogel S, Wolf G**, A pilot study of hormone replacement therapy with tibolone in women with mastopathic breasts, *Maturitas* 40:165, 2001.
776. **Kenemans P, Bundred NJ, Foidart J-M, Kubista E, Von Schoultz B, Sismondi P, Vassilopoulou-Sellin R, Yip CH, Egberts J, Mol-Arts M, Mulder R, van Os S, Beckmann MW**; On behalf of the **LIBERATE Study Group**, Safety and efficacy of tibolone in breast-cancer patients with vasomotor symptoms: a double-blind, randomised, non-inferiority trial, *Lancet Oncol* 10:135, 2009.
777. **Cummings SR, Ettinger B, Delmas PD, Kenemans P, Stathopoulos V, Verwij P, Mol-Arts M, Kloosterboer HJ, Mosca L, Christiansen C, Bilezikian J, Kerzberg EM, Johnson S, Zanchetta JR, Grobbee DE, Seifert W, Eastell R**; **LIFT Trial Investigators**, The effects of tibolone in older postmenopausal women, *N Engl J Med* 359:697, 2008.

778. **Wierik EJ, Hendricks PT, Boerstoeel-Streefland M**, Clinical background of women prescribed tibolone or combined estrogen + progestogen therapies: a UK MediPlus study, *Climacteric* 7:197, 2004.
779. **Velthuis-Te Wierik EJ, Hendricks PT, Martinez C**, Preferential prescribing of tibolone and combined estrogen plus progestogen therapy in postmenopausal women, *Menopause* 14:518, 2007.
780. **Lebherz TB, French LT**, Nonhormonal treatment of the menopausal syndrome. A double-blind evaluation of an autonomic system stabilizer, *Obstet Gynecol* 33:795, 1969.
781. **Bergmans MG, Merkus JM, Corbey RS, Schellekens LA, Ubachs JM**, Effect of Bellergal Retard on climacteric complaints: a double-blind, placebo-controlled study, *Maturitas* 9:227, 1987.
782. **David A, Don R, Tajchner G, Weissglas L**, Veralipride: alternative antidopaminergic treatment for menopausal symptoms, *Am J Obstet Gynecol* 158:1107, 1988.
783. **Melis GB, Bambacciani M, Cagnacci A, Paoletti AM, Mais V, Fioretti P**, Effects of the dopamine antagonist veralipride on hot flushes and luteinizing hormone secretion in postmenopausal women, *Obstet Gynecol* 72:688, 1988.
784. **Wesel S, Bourguignon RP, Bosuma WB**, Veralipride versus conjugated oestrogens: a double-blind study in the management of menopausal hot flushes, *Curr Med Res Opin* 8:696, 1984.
785. **Barton DL, Loprinzi CL, Quella SK, Sloan JA, Veeder MH, Egner JR, Fidler P, Stella PJ, Swan DK, Vaught NL, Novotny P**, Prospective evaluation of vitamin E for hot flashes in breast cancer survivors, *J Clin Oncol* 16:495, 1998.
786. **Hirata JD, Swiersz LM, Zell B, Small R, Ettinger B**, Does dong quai have estrogenic effects in postmenopausal women? A double-blind, placebo-controlled trial, *Fertil Steril* 68:981, 1997.
787. **Wiklund IK, Mattsson LA, Lindgren R, Limoni C**, Effects of a standardized ginseng extract on quality of life and physiological parameters in symptomatic postmenopausal women: a double-blind, placebo-controlled trial. Swedish Alternative Medicine Group, *Int J Clin Pharmacol Res* 19:89, 1999.
788. **Jacobson JS, Troxel AB, Evans J, Klaus L, Vahdat L, Kinne D, Lo KM, Moore A, Rosenman PJ, Kaufman EL, Neugut AI, Grann VR**, Randomized trial of black cohosh for the treatment of hot flashes among women with a history of breast cancer, *J Clin Oncol* 19:2739, 2001.
789. **Quella SK, Loprinzi CL, Barton DL, Knost JA, Sloan JA, LaVasseur BI, Swan D, Krupp KR, Miller KD, Novotny PJ**, Evaluation of soy phytoestrogens for the treatment of hot flashes in breast cancer survivors: a North Central Cancer Treatment Group trial, *J Clin Oncol* 18:1068, 2000.
790. **St. Germain A, Peterson CT, Robinson JG, Alekel DL**, Isoflavone-rich or isoflavone-poor soy protein does not reduce menopausal symptoms during 24 weeks of treatment, *Menopause* 8:17, 2001.
791. **Van Patten CL, Olivotto IA, Chambers GK, Gelmon KA, Hislop TG, Templeton E, Wattie A, Prior JC**, Effect of soy phytoestrogens on hot flashes in postmenopausal women with breast cancer: a randomized, controlled clinical trial, *J Clin Oncol* 20:1449, 2002.
792. **Pockaj BA, Gallagher JG, Loprinzi CL, Stella PJ, Barton DL, Sloan JA, Lavasseur BI, Rao RM, Fitch TR, Rowland KM, Novotny PJ, Flynn PJ, Richelson E, Fauq AH**, Phase III double-blind, randomized, placebo-controlled crossover trial of black cohosh in the management of hot flashes: NCCTG Trial NO1CC1, *J Clin Oncol* 24:2836, 2006.
793. **Krebs E, Ensrud KE, MacDonald R, Wilt T**, Phytoestrogens for treatment of menopausal symptoms: a systematic review, *Obstet Gynecol* 104:824, 2004.
794. **Vincent A, Barton DL, Mandrekar JN, Cha SS, Zais T, Wahner-Roedler DL, Keppler MA, Kreitzer MJ, Loprinzi C**, Acupuncture for hot flashes: a randomized, sham-controlled clinical study, *Menopause* 14:45, 2007.
795. **Deng G, Vickers A, Yeung S, D'Andrea GM, Xiao H, Heerdt AS, Sugarman S, Troso-Sandoval T, Seidman AD, Hudis CA, Cassileth B**, Randomized, controlled trial of acupuncture for the treatment of hot flashes in breast cancer patients, *J Clin Oncol* 25:5584, 2007.
796. **Lee MS, Kim JI, Ha JY, Boccy K, Ernst E**, Yoga for menopausal symptoms: a systematic review, *Menopause* 16:602, 2009.
797. **Krause MS, Nakajima ST**, Hormonal and nonhormonal treatment of vasomotor symptoms, *Obstet Gynecol Clin North Am* 42(1):163, 2015.

798. **Pandya KJ, Raubertas RF, Flynn PJ, Hynes HE, Rosenbluth RJ, Kirshner JJ, Pierce HI, Dragalin V, Morrow GR**, Oral clonidine in postmenopausal patients with breast cancer experiencing tamoxifen-induced hot flashes: a University of Rochester Cancer Center Community Clinical Oncology Program Study, *Ann Intern Med* 132(10):788, 2000.
799. **Lobo RA, McCormick W, Singer F, Roy S**, Depo-medroxyprogesterone acetate compared with conjugated estrogens for the treatment of postmenopausal women, *Am J Obstet Gynecol* 63:1, 1984.
800. **Loprinzi CL, Michalak JC, Quella SK, O'Fallon JR, Hatfield AK, Nelimark RA, Dose AM, Fischer T, Johnson C, Klatt NE, Bate WW, Rospond RM, Oesterling JE**, Megestrol acetate for the prevention of hot flashes, *N Engl J Med* 331:347, 1994.
801. **Goodwin JW, Green SJ, Moinpour CM, Bearden JD III, Giguere JK, Jiang CS, Lippman SM, Martino S, Albain KS**, Phase III randomized placebo-controlled trial of two doses of megestrol acetate as treatment for menopausal symptoms in women with breast cancer: Southwest Oncology Group Study 9626, *J Clin Oncol* 26:1650, 2008.
802. **Simon JA, Portman DJ, Kaunitz AM, Mekonnen H, Kazempour K, Bhaskar S, Lippman J**, Low-dose paroxetine 7.5 mg for menopausal vasomotor symptoms: two randomized controlled trials, *Menopause* 20(10):1027, 2013.
803. **Loprinzi CL, Pisansky TM, Fonseca R, Sloan JA, Zahasky KM, Quella SK, Novotny PJ, Rummans TA, Dumesic DA, Perez EA**, Pilot evaluation of venlafaxine hydrochloride for the therapy of hot flashes in cancer survivors, *J Clin Oncol* 16:2377, 1998.
804. **Loprinzi CL, Kugler JW, Sloan JA, Malliard JA, LaVasseur BI, Barton DL, Novotny PJ, Dakhil SR, Rodger K, Rummans TA, Christensen BJ**, Venlafaxine in management of hot flashes in survivors of breast cancer: a randomised controlled trial, *Lancet* 356:2059, 2000.
805. **Evans ML, Pritts E, Vittinghoff E, McClish K, Morgan KS, Jaffe RB**, Management of postmenopausal hot flushes with venlafaxine hydrochloride: a randomized, controlled trial, *Obstet Gynecol* 105(1):161, 2005.
806. **Speroff L, Gass M, Constantine G, Olivier S; Study 315 Investigators**, Efficacy and tolerability of desvenlafaxine succinate treatment for menopausal vasomotor symptoms: a randomized controlled trial, *Obstet Gynecol* 111:77, 2008.
807. **Archer DF, Dupont CM, Constantine GD, Pickar JH, Olivier S; for the Study 319 Investigators**, Desvenlafaxine for the treatment of vasomotor symptoms associated with menopause: a double-blind, randomized, placebo-controlled trial of efficacy and safety, *Am J Obstet Gynecol* 200:238.e1, 2009.
808. **Loprinzi CL, Sloan JA, Perez EA, Quella SK, Stella PJ, Mailliard JA, Halyard MY, Pruthi S, Novotny PJ, Rummans TA**, Phase III evaluation of fluoxetine for treatment of hot flashes, *J Clin Oncol* 20:1578, 2002.
809. **Kalay AE, Demir B, Haberal A, Kalay M, Kandemir O**, Efficacy of citalopram on climacteric symptoms, *Menopause* 14:223, 2007.
810. **Suvanto-Luukkonen E, Koivunen R, Sundström H, Bioigu R, Karjalainen E, Häivä-Mällinen L, Tapanainen JS**, Citalopram and fluoxetine in the treatment of postmenopausal symptoms: a prospective, randomized, 9-month, placebo-controlled, double-blind study, *Menopause* 12:18, 2005.
811. **Kimmick GG, Lovato J, McQuellon R, Robinson E, Muss HB**, Randomized, double-blind, placebo-controlled, crossover study of sertraline (Zoloft) for the treatment of hot flashes in women with early stage breast cancer taking tamoxifen, *Breast J* 12:114, 2006.
812. **Grady D, Cohen B, Tice J, Kristof M, Olyae A, Sawaya GF**, Ineffectiveness of sertraline for treatment of menopausal hot flushes. A randomized controlled trial, *Obstet Gynecol* 109:823, 2007.
813. **Guttuso T Jr, Kurlan R, McDermott MP, Kieburz K**, Gabapentin's effects on hot flashes in postmenopausal women: a randomized controlled trial, *Obstet Gynecol* 101:337, 2003.
814. **Butt DA, Lock M, Lewis JE, Ross S, Moineddin R**, Gabapentin for the treatment of menopausal hot flashes: a randomized controlled trial, *Menopause* 15:310, 2008.
815. **Toulis KA, Tzellos T, Kouvelas D, Goulis DG**, Gabapentin for the treatment of hot flashes in women with natural or tamoxifen-induced menopause: a systematic review and meta-analysis, *Clin Ther* 31:221, 2009.
816. **Reddy SY, Warner H, Guttuso T Jr, Messing S, DiGrazio W, Thornburg L, Guzik DS**, Gabapentin, estrogen, and placebo for treating hot flushes: a randomized controlled trial, *Obstet Gynecol* 108:41, 2006.

817. **Saadati N, Mohammadjafari R, Natanj S, Abedi P**, The effect of gabapentin on intensity and duration of hot flashes in postmenopausal women: a randomized controlled trial, *Glob J Health Sci* 5(6):126, 2013.
818. **Loprinzi CL, Qin R, Baclueva EP, Flynn KA, Rowland KM Jr, Graham DL, Erwin NK, Dakhil SR, Jurgens DJ, Burger KN**, Phase III, randomized, double-blind, placebo-controlled evaluation of pregabalin for alleviating hot flashes, N07C1, *J Clin Oncol* 28:641, 2010.
819. **Bardia A, Novotny PJ, Sloan JA, Barton D, Loprinzi C**, Efficacy of nonestrogenic hot flash therapies among women stratified by breast cancer history and tamoxifen use: a pooled analysis, *Menopause* 16:477, 2009.
820. **Stearns V, Johnson MD, Raae JM, Morocho A, Novielli A, Bhargava P, Hayes DF, Desta Z, Flockhart DA**, Active tamoxifen metabolite plasma concentrations after coadministration of tamoxifen and the selective serotonin reuptake inhibitor paroxetine, *J Natl Cancer Inst* 95:1758, 2003.
821. **Jin Y, Desta Z, Stearns V, Ward B, Ho H, Lee KH, Skaar T, Storniolo AM, Li L, Araba A, Blanchard R, Nguyen A, Ullmer L, Hayden J, Lemier S, Weinsilboum RM, Rae JM, Hayes DF, Flockhart DA**, CYP2D6 genotype, antidepressant use, and tamoxifen metabolism during adjuvant breast cancer treatment, *J Natl Cancer Inst* 97:30, 2005.
822. **Kelly CM, Juurlink DN, Gomes T, Duong-Hua M, Pritchard KI, Austin PC, Paszat LF**, Risk of death due to breast cancer in women treated with selective serotonin reuptake inhibitor antidepressants and tamoxifen, *San Antonio Breast Cancer Symposium*, Abstract 2049, December 9–13, 2009.
823. **Stuenkel CA**, Menopausal hormone therapy: current considerations, *Endocrinol Metab Clin North Am* 44(3):565, 2015.
824. **Gann PH, Giovanazzi S, Van Horn L, Branning A, Chatterton RT Jr**, Saliva as a medium for investigating intra- and interindividual differences in sex hormone levels in premenopausal women, *Cancer Epidemiol Biomarkers Prev* 10:59, 2001.
825. **Chatterton RT Jr, Mateo ET, Lu D, Ling FJ**, Interpopulational differences in the concentrations and ratios of salivary and serum progesterone, *Fertil Steril* 86:723, 2006.
826. **Flyckt RL, Liu J, Frasure H, Wekselman K, Buch A, Kinsberg SA**, Comparison of salivary versus serum testosterone levels in postmenopausal women receiving transdermal testosterone supplementation versus placebo, *Menopause* 16:680, 2009.
827. **American College of Obstetricians and Gynecologists Committee on Gynecologic Practice; American Society for Reproductive Medicine Practice Committee**, Compounded bioidentical menopausal hormone therapy, *Fertil Steril* 98(2):308, 2012.
828. **Patsner B**, Pharmacy compounding of bioidentical hormone replacement therapy (BHRT): a proposed new approach to justify FDA regulation of these prescription drugs, *Food Drug Law J* 63:459, 2008.
829. **Weiderpass E, Baron JA, Adami HO, Magnusson C, Lindgren A, Bergstrom R, Coppreia N, Persson I**, Low-potency oestrogen and risk of endometrial cancer: a case-control study, *Lancet* 353:1824, 1999.
830. **Cole MR, Fetrow CW**, Adulteration of dietary supplements, *Am J Health Syst Pharm* 60:1576, 2003.
831. **Murkies AL, Wilcox G, Davis SR**, Phytoestrogens, *J Clin Endocrinol Metab* 83:297, 1998.
832. **Tham DM, Gardner CD, Haskell WL**, Potential health benefits of dietary phytoestrogens: a review of the clinical, epidemiological, and mechanistic evidence, *J Clin Endocrinol Metab* 83:2223, 1998.
833. **Kuiper GGJM, Carlsson B, Grandien K, Enmark E, Häggblad J, Nilsson S, Gustafsson J**, Comparison of the ligand binding specificity and transcript tissue distribution of estrogen receptors  $\alpha$  and  $\beta$ , *Endocrinology* 138:863, 1997.
834. **Anderson RL, Wolf WJ**, Compositional changes in trypsin inhibitors, phytic acid, saponins and isoflavones related to soybean processing, *J Nutr* 125(Suppl):581S, 1995.
835. **Messina M**, Isoflavone intakes by Japanese were overestimated (letter to the editor), *Am J Clin Nutr* 62:645, 1995.
836. **Coward L, Barnes NC, Setchell KDR, Barnes S**, The isoflavones genistein and daidzein soybean foods from American and Asian diets, *J Agric Food Chem* 41:1961, 1993.
837. **Cassidy A, Bingham S, Setchell KDR**, Biological effects of a diet of soy protein rich in isoflavones on the menstrual cycle of premenopausal women, *Am J Clin Nutr* 60:333, 1994.

838. **Lethaby A, Marjoribanks J, Kronenberg F, Roberts H, Eden J, Brown J**, Phytoestrogens for menopausal vasomotor symptoms, *Cochrane Database Syst Rev* (12):Cd001395, 2013.
839. **Baber RJ, Templeman C, Morton T, Kelly GE, West L**, Randomized placebo-controlled trial of an isoflavone supplement and menopausal symptoms in women, *Climacteric* 2:85, 1999.
840. **Knight DC, Howes JB, Eden JA**, The effect of Promensil™, an isoflavone extract, on menopausal symptoms, *Climacteric* 2:79, 1999.
841. **van de Wijer PHM, Barentsen R**, Isoflavones from red clover (Promensil®) significantly reduce menopausal hot flush symptoms compared with placebo, *Maturitas* 42:187, 2002.
842. **Tice JA, Ettinger B, Ensrud K, Wallace R, Blackwell T, Cummings SR**, Phytoestrogen supplements for the treatment of hot flashes: the Isoflavone Clover Extract (ICE) Study. A randomized controlled trial, *JAMA* 290:207, 2003.
843. **Geller SE, Shulman LP, van Breemen RB, Banuvar S, Zhou Y, Epstein G, Hedayat S, Nikolic D, Krause EC, Piersen CE, Bolton JL, Pauli GF, Farnsworth NR**, Safety and efficacy of black cohosh and red clover for the management of vasomotor symptoms: a randomized controlled trial, *Menopause* 16:1156, 2009.
844. **Khoo SK, Munro C, Battistutta D**, Evening primrose oil and treatment of premenstrual syndrome, *Med J Aust* 153:189, 1990.
845. **Collins A, Cerin A, Coleman G, Landgren B-M**, Essential fatty acids in the treatment of premenstrual syndrome, *Obstet Gynecol* 81:93, 1993.
846. **Chenoy R, Hussain S, Tayob Y, O'Brien PM, Moss MY, Morse PF**, Effect of oral gamma-linolenic acid from evening primrose oil on menopausal flushing, *Br Med J* 308:501, 1994.
847. **Jiang B, Kronenberg F, Balick MJ, Kennelly EJ**, Analysis of formononetin from black cohosh (*Actaea racemosa*), *Phytomedicine* 13:477, 2006.
848. **Newton KM, Reed SD, Grothaus L, Ehrlich K, Gultinan J, Ludman E, LaCroix AZ**, The Herbal Alternatives for Menopause (HALT) Study: background and study design, *Maturitas* 52:134, 2005.
849. **Newton KM, Reed SD, Grothaus L, Lee K, Ehrlich K, LaCroix AZ**, The impact of hormone therapy and herbal remedies for menopause symptoms on sleep quality: the HALT trial (7th European Congress on Menopause, Abstract FCO8.5), *Maturitas* 54S:S52, 2006.
850. **Maki PM, Rugin LH, Fornelli D, Drogos L, Banuvar S, Shulman LP, Geller SE**, Effects of botanicals and combined hormone therapy on cognition in postmenopausal women, *Menopause* 16:1167, 2009.
851. **van der Sluijs CP, Bensoussan A, Chang S, Baber R**, A randomized placebo-controlled trial on the effectiveness of an herbal formula to alleviate menopausal vasomotor symptoms, *Menopause* 16:336, 2009.
852. **Mahady GB, Low Dog T, Barrett ML, Chavez ML, Gardiner P, Ko R, Marles RJ, Pellicore LS, Giancaspro GI, Sarma DN**, United States Pharmacopeia review of the black cohosh case reports of hepatotoxicity, *Menopause* 15:628, 2008.
853. **Teschke R, Bahre R, Fuchs J, Wolff A**, Black cohosh hepatotoxicity: quantitative causality evaluation in nine suspected cases, *Menopause* 16:956, 2009.
854. **DeKosky ST, Williamson JD, Fitzpatrick AL, Kronmal RA, Ives DG, Saxton JA, Lopez OL, Burke G, Carlson MC, Fried LP, Kuller LH, Robbins JA, Tracy RP, Woolard NF, Dunn L, Snitz BE, Nahin RL, Furberg CD; for the Ginkgo Evaluation of Memory (GEM) Study Investigators**, Ginkgo biloba for prevention of dementia. A randomized controlled trial, *JAMA* 300:2253, 2008.
855. **Snitz BE, O'Meara ES, Carlson MC, Arnold AM, Ives DG, Rapp SR, Saxton JA, Lopez OL, Dunn LO, Sink KM, DeKosky ST; for the Ginkgo Evaluation of Memory (GEM) Study Investigators**, Ginkgo biloba for preventing cognitive decline in older adults. A randomized trial, *JAMA* 302:2663, 2009.
856. **van Dongen MC, van Rossum E, Kessels AG, Sielhorst HJ, Knipschild PG**, The efficacy of ginkgo for elderly people with dementia and age-associated memory impairment: new results of a randomized clinical trial, *J Am Geriatr Soc* 48:1183, 2000.
857. **Solomon PR, Adams F, Silver A, Zimmer J, DeVeaux R**, Ginkgo for memory enhancement. A randomized controlled trial, *JAMA* 288:835, 2002.
858. **Pfister O, Sticherling C, Schaer B, Osswald S**, Electrical storm caused by complementary medication with



Ginkgo biloba extract, *Am J Med* 121:e3, 2008.

859. **Birks J, Grimley Evans J**, Ginkgo biloba for cognitive impairment and dementia, *Cochrane Database Syst Rev* (1):CD003120, 2007. doi: 10.1002/14651858.CD003120.pub2.
860. **Gaster B, Holroyd J**, St. John's wort for depression: a systematic review, *Arch Intern Med* 160:152, 2000.
861. **Kim HL, Streitzer J, Goebert D**, St. John's wort for depression: a meta-analysis of well-defined clinical trials, *J Nerv Ment Dis* 187:532, 1999.
862. **Linde K, Mulrow CD**, St John's wort for depression, *Cochrane Database Syst Rev* (2):CD000448, 2000.
863. **Shelton RC, Keller MB, Gelenberg A, Dunner DL, Hirschfeld R, Thase ME, Russell J, Lydiard RB, Crits-Cristoph P, Gallop R, Todd L, Hellerstein D, Goodnick P, Keitner G, Stahl SM, Halbreich U**, Effectiveness of St John's Wort in major depression. A randomized controlled trial, *JAMA* 285:1978, 2001.
864. **Hypericum Depression Trial Study Group**, Effect of Hypericum perforatum (St John's Wort) in major depressive disorder. A randomized controlled trial, *JAMA* 287:1807, 2002.
865. **Food and Drug Administration**, Risk of drug interactions with St. John's wort and indinavir and other drugs, *FDA Public Health Advisory*, February 10, 2000.
866. **Chen XW, Serag ES, Sneed KB, Liang J, Chew H, Pan SY, Zhou SF**, Clinical herbal interactions with conventional drugs: from molecules to maladies, *Curr Med Chem* 18(31):4836, 2011.
867. **Moore L, Goodwin B, Jones SA, Wisely GB, Serabjit-Singh CJ, Willson TM, Collins JL, Kliever SA**, St. John's wort induces hepatic drug metabolism through activation of the pregnane X receptor, *Proc Natl Acad Sci U S A* 97:7500, 2000.
868. **Anderson JW, Johnstone B, Cook-Newell ME**, Meta-analysis of the effects of soy protein intake on serum lipids, *N Engl J Med* 333:276, 1995.
869. **Clarkson TB, Anthony M, Morgan TM**, Inhibition of postmenopausal atherosclerosis progression: a comparison of the effects of conjugated equine estrogens and soy phytoestrogens, *J Clin Endocrinol Metab* 86:41, 2001.
870. **Greaves KA, Parks JS, Williams JK, Wagner JD**, Intact dietary soy protein, but not adding an isoflavone-rich soy extract to casein, improves plasma lipids in ovariectomized cynomolgus monkeys, *J Nutr* 129:1585, 1999.
871. **Greaves KA, Wilson MD, Rudel L, Williams JK, Wagner JD**, Consumption of soy protein reduces cholesterol absorption compared to casein protein alone or supplemented with an isoflavone extract or conjugated equine estrogen in ovariectomized cynomolgus monkeys, *J Nutr* 130:820, 2000.
872. **Anthony MS, Clarkson TB, Williams JK**, Effects of soy isoflavones on atherosclerosis: potential mechanisms, *Am J Clin Nutr* 68:1390S, 1998.
873. **Anthony MS, Clarkson TB, Hughes CL Jr, Morgan TM, Burke GL**, Soybean isoflavones improve cardiovascular risk factors without affecting the reproductive system of peripubertal Rhesus monkeys, *J Nutr* 126:43, 1996.
874. **Anthony MS, Clarkson TB**, Comparison of soy phytoestrogens and conjugated equine estrogens on atherosclerosis progression in postmenopausal monkeys (abstract), *Circulation* 90:829, 1998.
875. **Honoré EK, Williams JK, Anthony MS, Clarkson TB**, Soy isoflavones enhance coronary vascular reactivity in atherosclerotic female macaques, *Fertil Steril* 67:148, 1997.
876. **Williams JK, Anthony MS, Clarkson TB**, Interactive effects of soy protein and estradiol on coronary artery reactivity in atherosclerotic, ovariectomized monkeys, *Menopause* 8:307, 2001.
877. **Crouse JR III, Morgan T, Terry JG, Ellis J, Vitolins M, Burke GL**, A randomized trial comparing the effect of casein with that of soy protein containing varying amounts of isoflavones on plasma concentrations of lipids and lipoproteins, *Arch Intern Med* 159:2070, 1999.
878. **Potter SM, Baum JA, Teng H, Stillman RJ, Shay NF, Erdman JW Jr**, Soy protein and isoflavones: their effects on blood lipids and bone density in postmenopausal women, *Am J Clin Nutr* 68(Suppl):1375S, 1998.
879. **Washburn S, Burke GL, Morgan T, Anthony M**, Effect of soy protein supplementation on serum lipoproteins, blood pressure, and menopausal symptoms in perimenopausal women, *Menopause* 6:7, 1999.
880. **Merz-DeMlow BE, Duncan AM, Wangen KE, Xu X, Carr TP, Phipps WR, Kurzer MS**, Soy isoflavones improve plasma lipids in normocholesterolemic, premenopausal women, *Am J Clin Nutr* 71:1462, 2000.

881. **Teixeira SR, Potter SM, Weigel R, Hannum S, Erdman JW Jr, Hasler CM**, Effects of feeding 4 levels of soy protein for 3 and 6 week on blood lipids and apolipoproteins in moderately hypercholesterolemic men, *Am J Clin Nutr* 71:1077, 2000.
882. **Simons LA, von Konigsmark M, Simons J, Celermajer DS**, Phytoestrogens do not influence lipoprotein levels or endothelial function in healthy, postmenopausal women, *Am J Cardiol* 11:1297, 2000.
883. **Lichtenstein AH, Jalbert SM, Adlercreutz H, Goldin BR, Rasmussen H, Schaefer EJ, Ausman LM**, Lipoprotein response to diets high in soy or animal protein with and without isoflavones in moderately hypercholesterolemic subjects, *Arterioscler Thromb Vasc Biol* 22:1852, 2002.
884. **Kreijkamp-Kaspers S, Kok L, Grobbee DE, de Haan EH, Aleman A, Lampe JW, van der Schouw YT**, Effect of soy protein containing isoflavones on cognitive function, bone mineral density, and plasma lipids in postmenopausal women: a randomized controlled trial, *JAMA* 292:65, 2004.
885. **Jayagopal V, Albertazzi P, Kilpatrick ES, Howarth EM, Jennings PE, Hepburn DA, Atkin SL**, Beneficial effects of soy phytoestrogen intake in postmenopausal women with type 2 diabetes, *Diabetes Care* 25:1709, 2002.
886. **Jenkins DJA, Kendall CW, Vidgen E, Vuksan V, Jackson C, Augustin LS, Lee B, Garsetti M, Agarwal S, Rao AV, Cagampang GB, Fulgoni V**, Effect of soy based breakfast cereal on blood lipids and oxidized low density lipoprotein, *Metabolism* 49:1496, 2000.
887. **Nestel PJ, Pomeroy S, Kay S, Komesaroff P, Behrsing J, Cameron JD, West L**, Isoflavones from red clover improve systemic arterial compliance but not plasma lipids in menopausal women, *J Clin Endocrinol Metab* 84:895, 1999.
888. **Food and Drug Administration**, Food labelling: health claims; soy protein and coronary heart disease, *Fed Regist* 64:57699, 1999.
889. **Upmalis DH, Lobo R, Bradley L, Warren M, Cone FL, Camia CA**, Vasomotor symptom relief by soy isoflavone extract tablets in postmenopausal women: a multicenter, double-blind, randomized, placebo-controlled study, *Menopause* 7:236, 2000.
890. **Hodgson JM, Puddey IB, Beilin LJ, Mori TA, Croft KD**, Supplementation with isoflavonoid phytoestrogens does not alter serum lipid concentrations: a randomized controlled trial in humans, *J Nutr* 128:728, 1998.
891. **Dewell A, Hollenbeck CB, Bruce B**, The effects of soy-derived phytoestrogens on serum lipids and lipoproteins in moderately hypercholesterolemic postmenopausal women, *J Clin Endocrinol Metab* 87:118, 2002.
892. **Pan Y, Anthony M, Clarkson TB**, Effect of estradiol and soy phytoestrogens on choline acetyltransferase and nerve growth factor mRNAs in the frontal cortex and hippocampus of female rats, *Proc Soc Exp Biol Med* 221:118, 1999.
893. **Pan Y, Anthony M, Watson S, Clarkson TB**, Soy phytoestrogens improve radial arm maze performance in ovariectomized retired breeder rats and do not attenuate benefits of 17beta-estradiol treatment, *Menopause* 7:230, 2000.
894. **Kritz-Silverstin D, Von Muhlen D, Barrett-Conner E**, Isoflavones and cognitive function in older women: the SOy and Postmenopausal Health in Aging (SOPHIA) Study, *Menopause* 10:196, 2003.
895. **Duffy R, Wiseman H, File SE**, Improved cognitive function in postmenopausal women after 12 weeks of consumption of a soya extract containing isoflavones, *Pharmacol Biochem Behav* 75:721, 2003.
896. **Kreijkamp-Kaspers S, Grobbee DE, Lampe JW, van der Schouw YT**, A randomized, placebo-controlled trial on the effects of soy protein containing isoflavones on quality of life in postmenopausal women, *Menopause* 12:56, 2005.
897. **Ho SC, Chan ASY, Ho YP, So EKF, Sham A, Zee B, Woo JLF**, Effects of soy isoflavone supplementation on cognitive function in Chinese postmenopausal women: a double-blind, randomized, controlled trial, *Menopause* 14:489, 2007.
898. **White LR, Petrovitch H, Ross GW, Masaki K, Hardman J, Nelson J, Davis D, Markesbery W**, Brain aging and midlife tofu consumption, *J Am Coll Nutr* 19:242, 2000.
899. **Adlercreutz H, Mazur W**, Phyto-oestrogens and western diseases, *Ann Med* 29:95, 1997.
900. **Goodman MT, Wilkens LR, Hankin JH, Lyu L-C, Wu AH, Kolonel LN**, Association of soy and fiber

consumption with the risk of endometrial cancer, *Am J Epidemiol* 146:294, 1997.

901. **Ingram D, Sanders K, Kolybaba M, Lopez D**, Case-control study of phyto-oestrogens and breast cancer, *Lancet* 350:990, 1997.
902. **Murkies A, Dalais FS, Briganti EM, Burger HG, Healy DL, Wahlqvist ML, Davis SR**, Phytoestrogens and breast cancer in postmenopausal women: a case control study, *Menopause* 7:289, 2000.
903. **Lee HP, Gourley L, Duffy SW, Esteve J, Lee J, Day NE**, Dietary effect on breast cancer risk in Singapore, *Lancet* 337:1197, 1991.
904. **Wu AH, Ziegler RG, Horn-Ross PL, Nomura AMY, West DW, Kolonel LN, Rosenthal JF, Hoover RN, Pike MC**, Tofu and risk of breast cancer in Asian-Americans, *Cancer Epidemiol Biomarkers Prev* 5:901, 1996.
905. **Dai Q, Franke AA, Jin F, Shu XO, Hebert JR, Custer LJ, Cheng J, Gao YT, Zheng W**, Urinary excretion of phytoestrogens and risk of breast cancer among Chinese women in Shanghai, *Cancer Epidemiol Biomarkers Prev* 11:815, 2002.
906. **Lee SA, Shu XO, Li H, Yang G, Cai H, Wen W, Ji BT, Gao J, Gao YT, Zheng W**, Adolescent and adult soy food intake and breast cancer risk: results from the Shanghai Women's Health Study, *Am J Clin Nutr* 89:1920, 2009.
907. **Goodman MT, Shvetsov YB, Wilkens LR, Franke AA, Le Marchand L, Kakazu KK, Nomura AM, Henderson BE, Kolonel LN**, Urinary phytoestrogen excretion and postmenopausal breast cancer risk: the multiethnic cohort study, *Cancer Prev Res (Phila)* 2:887, 2009.
908. **Messina MJ, Persky V, Setchell KDR, Barnes S**, Soy intake and cancer risk: a review of the in vitro and in vivo data, *Nutr Cancer* 21:113, 1994.
909. **Petrakis NL, Barnes S, King EB, Lowenstein J, Wiencke J, Lee MM, Miike R, Kirk M, Coward L**, Stimulatory influence of soy protein isolate on breast secretion in pre- and postmenopausal women, *Cancer Epidemiol Biomark Prev* 5:785, 1996.
910. **Hedelin M, Löf M, Olsson M, Adlercreutz H, Sandin S, Weiderpass E**, Dietary phytoestrogens are not associated with risk of overall breast cancer but diets rich in coumestrol are inversely associated with risk of estrogen receptor and progesterone receptor negative breast tumors in Swedish women, *J Nutr* 138:938, 2008.
911. **Ward HA, Kuhnle GG, Mulligan AA, Lentjes MA, Luben RN, Khaw KT**, Breast, colorectal, and prostate cancer risk in the European Prospective Investigation into Cancer and Nutrition-Norfolk in relation to phytoestrogen intake derived from an improved database, *Am J Clin Nutr* 91:440, 2010.
912. **Lamartiniere CA**, Protection against breast cancer with genistein: a component of soy, *Am J Clin Nutr* 71(Suppl):1705S, 2000.
913. **Cohen LA, Zhao Z, Pittman B, Scimeca JA**, Effect of intact and isoflavone-depleted soy protein on NMU-induced rat mammary tumorigenesis, *Carcinogenesis* 21:929, 2000.
914. **Foth D, Cline JM**, Effects of mammalian and plant estrogens on mammary glands and uteri of macaques, *Am J Clin Nutr* 68(Suppl):1413S, 1998.
915. **Foth D, Cline JM, Romer T**, Effect of isoflavones on mammary gland and endometrium of postmenopausal macaques (*Macaca fascicularis*), *Zentralbl Gynakol* 122:96, 2000.
916. **Lu L-JW, Anderson KE, Grady JJ, Nagamani M**, Effects of soya consumption for one month on steroid hormones in premenopausal women: implications for breast cancer risk reduction, *Cancer Epidemiol Biomark Prev* 5:63, 1996.
917. **Wu AH, Stanczyk FZ, Hendrich S, Murphy PA, Zhang C, Pike MC**, Effects of soy foods on ovarian function in premenopausal women, *Br J Cancer* 82:1879, 2000.
918. **Lu LW, Anderson KE, Grady JJ, Nagamani M**, Effects of an isoflavone-free soy diet on ovarian hormones in premenopausal women, *J Clin Endocrinol Metab* 86:3045, 2001.
919. **Martini MC, Dancisak BB, Haggans CJ, Thomas W, Slavin JL**, Effects of soy intake on sex hormone metabolism in premenopausal women, *Nutr Cancer* 34:133, 1999.
920. **Baird DD, Umbach DM, Lansdell L, Hughes CL, Setchell KD, Weinberg CR, Haney AF, Wilcox AJ, Mclachlan JA**, Dietary intervention study to assess estrogenicity of dietary soy among postmenopausal women, *J Clin Endocrinol Metab* 80:1685, 1995.

921. **Duncan AM, Underhill KE, Xu X, Lavalleur J, Phipps WR, Kurzer MS**, Modest hormonal effects of soy isoflavones in postmenopausal women, *J Clin Endocrinol Metab* 84:3479, 1999.
922. **Lu LJ, Cree M, Josyula S, Nagamani M, Grady JJ, Anderson KE**, Increased urinary excretion of 2-hydroxyestrone but not 16 $\alpha$ -hydroxyestrone in premenopausal women during a soya diet containing isoflavones, *Cancer Res* 60:1299, 2000.
923. **Fuhrman BJ, Pfeiffer R, Xu X, Wu AH, Korde L, Gail MH, Keefer LK, Veenstra TD, Hoover RN, Ziegler RG**, Soy intake is associated with increased 2-hydroxylation and decreased 16 $\alpha$ -hydroxylation of estrogens in Asian-American women, *Cancer Epidemiol Biomarkers Prev* 18:2751, 2009.
924. **Hargreaves DF, Potten CS, Harding C, Shaw LE, Morton MS, Roberts SA, Howell A, Bundred NJ**, Two-week dietary soy supplementation has an estrogenic effect on normal premenopausal breast, *J Clin Endocrinol Metab* 84:4017, 1999.
925. **McMichael-Phillips DF, Harding C, Morton M, Roberts SA, Howell A, Potten CS, Bundred NJ**, Effects of soy-protein supplementation on epithelial proliferation in the histologically normal breast, *Am J Clin Nutr* 68(Suppl):1431S, 1998.
926. **Shu XO, Zheng Y, Cai H, Gu K, Chen Z, Zheng W, Lu W**, Soy food intake and breast cancer survival, *JAMA* 302:2483, 2009.
927. **Guha N, Kwan ML, Quesenberry CP Jr, Weltzien EK, Castillo AL, Caan BJ**, Soy isoflavones and risk of cancer recurrence in a cohort of breast cancer survivors: the Life After Cancer Epidemiology study, *Breast Cancer Res Treat* 118:395, 2009.
928. **Scambia G, Mango D, Signorile PG, Angeli RA, Palena C, Gallo D, Bombardelli E, Morazzoni P, Riva A, Mancuso S**, Clinical effects of a standardized soy extract in postmenopausal women: a pilot study, *Menopause* 7:105, 2000.
929. **Penotti M, Fabio E, Modena AB, Rinaldi M, Omodei U, Viganò P**, Effect of soy-derived isoflavones on hot flushes, endometrial thickness, and the pulsatility index of the uterine and cerebral arteries, *Fertil Steril* 79:1112, 2003.
930. **Komesaroff PA, Black C, Cable V, Sudhir K**, Effects of wild yam extract on menopausal symptoms, lipids and sex hormones in healthy menopausal women, *Climacteric* 4:144, 2001.
931. **Stanczyk FZ, Paulson RJ, Roy S**, Percutaneous administration of progesterone: blood levels and endometrial protection, *Menopause* 12:232, 2005.
932. **Balk JL, Whiteside DA, Naus G, DeFerrari E, Roberts JM**, A pilot study of the effects of phytoestrogen supplementation on postmenopausal endometrium, *J Soc Gynecol Investig* 9:238, 2002.
933. **Morito K, Hirose T, Kinjo J, Hirakawa T, Okawa M, Nohara T, Ogawa S, Inoue S, Muramatsu M, Masamune Y**, Interaction of phytoestrogens with estrogen receptors alpha and beta, *Biol Pharm Bull* 24:351, 2001.
934. **Setchell KDR, Brown NM, Lydeking-Olsen E**, The clinical importance of the metabolite equol—a clue to the effectiveness of soy and its isoflavones, *J Nutr* 132:3577, 2002.
935. **Lydeking-Olsen, Beck-Jensen JE, Setchell KD, Holm-Jensen T**, Soymilk or progesterone for prevention of bone loss—a 2 year randomized, placebo-controlled trial, *Eur J Nutr* 43:246, 2004.
936. **Ishiwata N, Melby MK, Mizuno S, Watanabe S**, New equol supplement for relieving menopausal symptoms: randomized, placebo-controlled trial of Japanese women, *Menopause* 16:141, 2009.
937. **Setchell KD, Zhao X, Jha P, Heubi JE, Brown NM**, The pharmacokinetic behavior of the soy isoflavone metabolite S-(–)equol and its diastereoisomer R-(+)equol in healthy adults determined by using stable-isotope-labeled tracers, *Am J Clin Nutr* 90:1029, 2009.
938. **Setchell KD, Zhao X, Shoaf SE, Ragland K**, The pharmacokinetics of S-(–)equol administered as SE5-OH tablets to healthy postmenopausal women, *J Nutr* 139:2037, 2009.
939. **Lund TD, Munson DJ, Haldy ME, Setchell KD, Lephart ED, Handa RJ**, Equol is a novel anti-androgen that inhibits prostate growth and hormone feedback, *Biol Reprod* 70:1188, 2004.
940. **Takahashi K, Okada M, Ozaki T, Kurioka H, Manabe A, Kanasaki H, Miyazaki K**, Safety and efficacy of oestriol for symptoms of natural or surgically induced menopause, *Hum Reprod* 15:1028, 2000.
941. **Grodstein F, Stampfer MJ, Falkeborn M, Naessen T, Persson I**, Postmenopausal hormone therapy and

- risk of cardiovascular disease and hip fracture in a cohort of Swedish women, *Epidemiology* 10:476, 1999.
942. **Cooper A, Spencer C, Whitehead MI, Ross D, Barnard GJR, Collins WP**, Systemic absorption of progesterone from Progest cream in postmenopausal women, *Lancet* 351:1255, 1998.
  943. **Carey BJ, Carey AH, Patel S, Carter G, Studd JWW**, A study to evaluate serum and urinary hormone levels following short and long term administration of two regimens of progesterone cream in postmenopausal women, *Br J Obstet Gynaecol* 107:722, 2000.
  944. **Burry KA, Patton PE, Hermsmeyer K**, Percutaneous absorption of progesterone in postmenopausal women treated with transdermal estrogen, *Am J Obstet Gynecol* 180:1504, 1999.
  945. **Leonetti HB, Longo S, Anasti JN**, Transdermal progesterone cream for vasomotor symptoms and postmenopausal bone loss, *Obstet Gynecol* 94:225, 1999.
  946. **Benster B, Carey A, Wadsworth F, Vashisht A, Domoney C, Studd J**, A double-blind placebo-controlled study to evaluate the effect of progestelle progesterone cream on postmenopausal women, *Menopause Int* 15:63, 2009.
  947. **Wren BG, McFarland K, Edwards L, O'Shea P, Sufi S, Gross B, Eden JA**, Effect of sequential transdermal progesterone cream on endometrium, bleeding pattern, and plasma progesterone and salivary progesterone levels in postmenopausal women, *Climacteric* 3:155, 2000.
  948. **Wren BG, Champion SM, Willetts K, Manga RZ, Eden JA**, Transdermal progesterone and its effect on vasomotor symptoms, blood lipid levels, bone metabolic markers, moods, and quality of life for postmenopausal women, *Menopause* 10:13, 2003.
  949. **O'Leary P, Feddema P, Chan K, Taranto M, Smith M, Evans S**, Salivary, but not serum or urinary levels of progesterone are elevated after topical application of progesterone cream to pre- and postmenopausal women, *Clin Endocrinol* 53:615, 2000.
  950. **Lewis JG, McGill H, Patton V, Elder PA**, Caution on the use of saliva measurements to monitor absorption of progesterone from transdermal creams in postmenopausal women, *Maturitas* 41:1, 2002.
  951. **Stanczyk FZ**, Treatment of postmenopausal women with topical progesterone creams and gels: are they effective? *Climacteric* 17(Suppl 2):8, 2014.
  952. **Nand S, Webster MA, Baber R, O'Connor V**; for the **Ogen/Provera Study Group**, Bleeding pattern and endometrial changes during continuous combined hormone replacement therapy, *Obstet Gynecol* 91:678, 1998.
  953. **Padwick ML, Psryse-Davies J, Whitehead MI**, A simple method for determining the optimal dosage of progestin in postmenopausal women receiving estrogens, *N Engl J Med* 315:930, 1986.
  954. **Sturdee DW, Barlow DH, Ulrich LG, Wells M, Gydesen H, Campbell M, O'Brien K, Vessey M**; for the **UK Continuous Combined HRT Study Investigators**, Is the timing of withdrawal bleeding a guide to endometrial safety during sequential oestrogen-progestagen replacement therapy?, *Lancet* 344:979, 1994.
  955. **Langer RD, Pierce JJ, O'Hanlan KA, Johnson SR, Espeland MA, Trabala JF, Barnabei VM, Merino MJ, Scully RE**; for the **Postmenopausal Estrogen/Progestin Interventions Trial**, Transvaginal ultrasonography compared with endometrial biopsy for the detection of endometrial disease, *N Engl J Med* 337:1792, 1997.
  956. **American College of Obstetricians and Gynecologists**, The role of transvaginal ultrasonography in evaluating the endometrium of women with postmenopausal bleeding. Committee Opinion No. 734, *Obstet Gynecol* 131:e124, 2018.
  957. **Botsis D, Kassanos D, Pyrgiotis E, Zourlas PA**, Vaginal sonography of the endometrium in postmenopausal women, *Clin Exp Obstet Gynecol* 19:189, 1992.
  958. **Karlsson B, Granberg S, Wikland M, Ylöstalo P, Torvid K, Marsal K, Valentin L**, Transvaginal ultrasonography of the endometrium in women with postmenopausal bleeding—a Nordic Multicenter Study, *Am J Obstet Gynecol* 172:1488, 1995.
  959. **Bakos O, Smith P, Heimer G**, Transvaginal ultrasonography for identifying endometrial pathology in postmenopausal women, *Maturitas* 20:181, 1995.
  960. **Granberg S, Ylöstalo P, Wikland M, Karlsson B**, Endometrial sonographic and histologic findings in women with and without hormonal replacement therapy suffering from postmenopausal bleeding, *Maturitas* 27:35, 1997.

961. ACOG Committee Opinion No. 734: the role of transvaginal ultrasonography in evaluating the endometrium of women with postmenopausal bleeding, *Obstet Gynecol* 131(5):e124, 2018.
962. **Hänggi W, Bersinger N, Altermatt HJ, Birkhäuser MH**, Comparison of transvaginal ultrasonography and endometrial biopsy in endometrial surveillance in postmenopausal HRT users, *Maturitas* 27:133, 1997.
963. **Affinito P, Palomba S, Sammartino A, Bonifacio M, Nappi C**, Ultrasonographic endometrial monitoring during continuous-sequential hormonal replacement therapy regimen in postmenopausal women, *Maturitas* 39:239, 2001.
964. **Van den Bosch T, Van Schoubroeck D, Ameye L, De Brabanter J, Van Huffel S, Timmerman D**, Ultrasound assessment of endometrial thickness and endometrial polyps in women on hormonal replacement therapy, *Am J Obstet Gynecol* 188:1249, 2003.
965. **Omodei U, Ferrazzia E, Ruggeri C, Palai N, Fallo L, Dordoni D, Perugino G**, Endometrial thickness and histological abnormalities in women on hormonal replacement therapy: a transvaginal ultrasound/hysteroscopic study, *Ultrasound Obstet Gynecol* 15:317, 2000.
966. **Sladkevicius P, Valentin L, Marsal K**, Endometrial thickness and Doppler velocimetry of the uterine arteries as discriminators of endometrial status in women with postmenopausal bleeding: a comparative study, *Am J Obstet Gynecol* 171:722, 1994.
967. **Conoscenti G, Meir YJ, Fischer-Tamaro L, Maieron A, Natale R, D'Ottavio G, Rustico M, Mandruzzato G**, Endometrial assessment by transvaginal sonography and histological findings after D & C in women with postmenopausal bleeding, *Ultrasound Obstet Gynecol* 6:108, 1995.
968. **Symons J, Kempfert N, Speroff L**, Vaginal bleeding in postmenopausal women taking low-dose norethindrone acetate and ethinyl estradiol combinations. The FemHRT Study Investigators, *Obstet Gynecol* 96:366, 2000.
969. **Simon JA, Symons J; femhrt Study Investigators**, Unscheduled bleeding during initiation of continuous combined hormone replacement therapy: a direct comparison of two combinations of norethindrone acetate and ethinyl estradiol to medroxyprogesterone acetate and conjugated equine estrogens, *Menopause* 8:321, 2001.
970. **Simon JA, Liu JH, Speroff L, Shumel BS, Symons JP**, Reduced vaginal bleeding in postmenopausal women who receive combined norethindrone acetate and low-dose ethinyl estradiol therapy versus combined conjugated equine estrogens and medroxyprogesterone acetate, *Am J Obstet Gynecol* 188:92, 2003.
971. **Andersson K, Mattsson L, Rybo G, Stadberg E**, Intrauterine release of levonorgestrel—a new way of adding progestogen in hormone replacement therapy, *Obstet Gynecol* 79:963, 1992.
972. **McGonigle KF, Karlan BY, Barbuto DA, Leuchter RS, Lagasse LD, Judd HL**, Development of endometrial cancer in women on estrogen and progestin hormone replacement therapy, *Gynecol Oncol* 55:126, 1994.
973. **Eriksson M, Berglund L, Rudling M, Henriksson P, Angelin B**, Effects of estrogen on low density lipoprotein metabolism in males. Short-term and long-term studies during hormonal treatment of prostatic cancer, *J Clin Invest* 84:802, 1989.
974. **Walsh BW, Schiff I, Rosner B, Greenberg L, Ravnikar V, Sacks FM**, Effects of postmenopausal estrogen replacement on the concentrations and metabolism of plasma lipoproteins, *N Engl J Med* 325:1196, 1991.
975. **Muesing R, Miller V, LaRosa J, Stoy D, Phillips E**, Effects of unopposed conjugated equine estrogen on lipoprotein composition and apolipoprotein-E distribution, *J Clin Endocrinol Metab* 75:1250, 1992.
976. **Manning JM, Edwards IJ, Wagner WD, Wagner JD, Adams MR, Parks JS**, Effects of contraceptive estrogen and progestin on the atherogenic potential of plasma LDLs in Cynomolgus monkeys, *Arterioscler Thromb Vasc Biol* 17:1216, 1997.
977. **Campos H, Walsh BW, Judge H, Sacks FM**, Effect of estrogen on very low density lipoprotein and low density lipoprotein subclass metabolism in postmenopausal women, *J Clin Endocrinol Metab* 82:3955, 1997.
978. **Espeland MA, Marcovina SM, Miller V, Wood PD, Wasilauskas C, Sherwin R, Schrott H, Bush TL**, Effect of postmenopausal hormone therapy on lipoprotein(a) concentration, *Circulation* 97:979, 1998.
979. **Nabulsi A, Folsom A, White A, Patsch W, Heiss G, Wu K, Szklo M**, Association of hormone-replacement therapy with various cardiovascular risk factors in postmenopausal women, *N Engl J Med*

328:1069, 1993.

980. **Christiansen C, Riis BJ**, Five years with continuous combined oestrogen/progestogen therapy. Effects on calcium metabolism, lipoproteins, and bleeding pattern, *Br J Obstet Gynaecol* 97:1087, 1990.
981. **Lobo R, Pickar J, Wild R, Walsh B, Hirvonen E**, Metabolic impact of adding medroxyprogesterone acetate to conjugated estrogen therapy in postmenopausal women. The Menopause Study Group, *Obstet Gynecol* 84:987, 1994.
982. **Munk-Jensen N, Ulrich L, Obel E, Nielsen S, Edwards D, Meinertz H**, Continuous combined and sequential estradiol and norethindrone acetate treatment of postmenopausal women: effect on plasma lipoproteins in a two-year placebo-controlled trial, *Am J Obstet Gynecol* 171:132, 1994.
983. **Folsom AR, McGovern PG, Nabulsi AA, Shahar E, Kahn ESB, Winkhart SP, White AD**; for the **Atherosclerosis Risk in Communities Study Investigators**, Changes in plasma lipids and lipoproteins associated with starting or stopping postmenopausal hormone replacement therapy, *Am Heart J* 132:952, 1996.
984. **Barrett-Connor E, Slone S, Greendale G, Kritz-Silverstein D, Espeland M, Johnson SR, Waclawiw M, Fineberg SE**, The Postmenopausal Estrogen/Progestin Interventions Study: primary outcomes in adherent women, *Maturitas* 27:261, 1997.
985. **Davidson MH, Testolin LM, Maki KC, von Duvillard S, Drennan KB**, A comparison of estrogen replacement, pravastatin, and combined treatment for the management of hypercholesterolemia in postmenopausal women, *Arch Intern Med* 157:1186, 1997.
986. **Adams MR, Clarkson TB, Koritnik DR, Nash HA**, Contraceptive steroids and coronary artery atherosclerosis in cynomolgus macaques, *Fertil Steril* 47:1010, 1987.
987. **Clarkson TB, Adams MR, Kaplan JR, Shively CA, Koritnik DR**, From menarche to menopause: coronary artery atherosclerosis and protection in cynomolgus monkeys, *Am J Obstet Gynecol* 160:1280, 1989.
988. **Clarkson TB, Shively CA, Morgan TM, Koritnik DR, Adams MR, Kaplan JR**, Oral contraceptives and coronary artery atherosclerosis of cynomolgus monkeys, *Obstet Gynecol* 75:217, 1990.
989. **Kushwaha R, Hazzard W**, Exogenous estrogens attenuate dietary hypercholesterolemia and atherosclerosis in the rabbit, *Metabolism* 30:57, 1981.
990. **Hough JL, Zilversmit DB**, Effect of 17 beta estradiol on aortic cholesterol content and metabolism in cholesterol-fed rabbits, *Arteriosclerosis* 6:57, 1986.
991. **Henriksson P, Stamberger M, Eriksson M, Rudling M, Diczfalusy U, Berglund L, Angelin B**, Oestrogen-induced changes in lipoprotein metabolism: role in prevention of atherosclerosis in the cholesterol-fed rabbit, *Eur J Clin Invest* 19:395, 1989.
992. **Haarbo J, Leth-Espensen P, Stender S, Christiansen C**, Estrogen monotherapy and combined estrogen-progestogen replacement therapy attenuate aortic accumulation of cholesterol in ovariectomized cholesterol-fed rabbits, *J Clin Invest* 87:1274, 1991.
993. **Adams MR, Kaplan JR, Manuck SB, Koritnik DR, Parks JS, Wolfe MS, Clarkson TB**, Inhibition of coronary artery atherosclerosis by 17-beta estradiol in ovariectomized monkeys. Lack of an effect of added progesterone, *Arteriosclerosis* 10:1051, 1990.
994. **Williams JK, Anthony MS, Honoré EK, Herrington DM, Morgan TM, Register TC, Clarkson TB**, Regression of atherosclerosis in female monkeys, *Arterioscler Thromb Vasc Biol* 15:827, 1995.
995. **Wagner JD, St. Clair RW, Schwenke DC, Shively CA, Adams MR, Clarkson TB**, Regional differences in arterial low density lipoprotein metabolism in surgically postmenopausal Cynomolgus monkeys: effects of estrogen and progesterone replacement, *Arterioscler Thromb* 12:716, 1992.
996. **Shwaery GT, Vita JA, Keane JF Jr**, Antioxidant protection of LDL by physiological concentrations of 17 beta-estradiol. Requirement for estradiol modification, *Circulation* 95:1378, 1997.
997. **Vihma V, Vehkavaara S, Yki-Järvinen H, Hohtari H, Tikkanen MJ**, Differential effects of oral and transdermal estradiol treatment on circulating estradiol fatty acid ester concentrations in postmenopausal women, *J Clin Endocrinol Metab* 88:588, 2003.
998. **Polderman KH, Stehouwer DC, van Kamp GJ, Dekker GA, Verheugt FW, Gooren LJ**, Influence of sex hormones on plasma endothelin levels, *Ann Intern Med* 118:429, 1993.
999. **Wilcox JG, Hatch IE, Gentzschlein E, Stanczyk FZ, Lobo RA**, Endothelin levels decrease after oral and

nonoral estrogen in postmenopausal women with increased cardiovascular risk factors, *Fertil Steril* 67:273, 1997.

1000. **Bar J, Tepper R, Fuchs J, Pardo Y, Goldberger S, Ovadia J**, The effect of estrogen replacement therapy on platelet aggregation and adenosine triphosphate release in postmenopausal women, *Obstet Gynecol* 81:261, 1993.
1001. **Aune B, Øian P, Omsjo P, Østerud B**, Hormone replacement therapy reduces the reactivity of monocytes and platelets in whole blood—a beneficial effect on atherogenesis and thrombus formation?, *Am J Obstet Gynecol* 173:1816, 1995.
1002. **Ganger KF, Vyas S, Whitehead MI, Crook D, Miere H, Campbell S**, Pulsatility index in the internal carotid artery is influenced by transdermal oestradiol and time since menopause, *Lancet* 338:839, 1991.
1003. **Hillard TC, Bourne TH, Whitehead MI, Crayford TB, Collins WP, Campbell S**, Differential effects of transdermal estradiol and sequential progestogens on impedance to flow within the uterine arteries of postmenopausal women, *Fertil Steril* 58:959, 1992.
1004. **Zegura B, Keber I, Sebestjen M, Borko E**, Orally and transdermally replaced estradiol improves endothelial function in middle-aged women after surgical menopause, *Am J Obstet Gynecol* 188:1291, 2003.
1005. **Collins P, Shay J, Jiang C, Moss J**, Nitric oxide accounts for dose-dependent estrogen-mediated coronary relaxation after acute estrogen withdrawal, *Circulation* 90:1964, 1994.
1006. **Gilligan DM, Badar DM, Panza JA, Quyyumi AA, Cannon RO III**, Acute vascular effects of estrogen in postmenopausal women, *Circulation* 90:786, 1994.
1007. **Gilligan DM, Badar DM, Panza JL, Quyyumi AA, Cannon RO III**, Effects of estrogen replacement therapy on peripheral vasomotor function in postmenopausal women, *Am J Cardiol* 75:264, 1995.
1008. **Mercuro G, Vitale C, Fini M, Zoncu S, Leonardo F, Rosano GM**, Lipid profiles and endothelial function with low-dose hormone replacement therapy in postmenopausal women at risk for coronary artery disease: a randomized trial, *Int J Cardiol* 89:257, 2003.
1009. **McCrohon JA, Adams MR, McCredie RJ, Robinson J, Pike A, Abbey M, Keech AC, Celermajer DS**, Hormone replacement therapy is associated with improved arterial physiology in healthy post-menopausal women, *Clin Endocrinol* 45:435, 1996.
1010. **Lau TK, Wan D, Yim SF, Sanderson JE, Haines CJ**, Prospective, randomized, controlled study of the effect of hormone replacement therapy on peripheral blood flow velocity in postmenopausal women, *Fertil Steril* 70:284, 1998.
1011. **Koh KK, Jin DK, Yang SH, Lee S-K, Hwang HY, Kang MH, Kim W, Kim DS, Choi IS, Shin EK**, Vascular effects of synthetic or natural progestagen combined with conjugated equine estrogen in healthy postmenopausal women, *Circulation* 103:1961, 2001.
1012. **Sjorenson KE, Dorup I, Hermann AP, Mosekilde L**, Combined hormone replacement therapy does not protect women against the age-related decline in endothelium-dependent vasomotor function, *Circulation* 97:1234, 1998.
1013. **Weiner CP, Lizasoain I, Baylis SA, Knowles RG, Charles IG, Moncada S**, Induction of calcium-dependent nitric oxide synthases by sex hormones, *Proc Natl Acad Sci U S A* 91:5212, 1994.
1014. **Hayashi T, Fukuto JM, Ignarro L, Chaudhuri G**, Basal release of nitric oxide from aortic rings is greater in female rabbits than in male rabbits: implications for atherosclerosis, *Proc Natl Acad Sci U S A* 89:11259, 1992.
1015. **Rosselli M, Imthurn B, Keller PJ, Jackson EK, Dubey RK**, Circulating nitric oxide (nitrite/nitrate) levels in postmenopausal women substituted with 17 beta-estradiol and norethisterone acetate. A two-year follow-up study, *Hypertension* 25:848, 1995.
1016. **Imthurn B, Rosselli M, Jaeger AW, Keller PJ, Dubey RK**, Differential effects of hormone-replacement therapy on endogenous nitric oxide (nitrite/nitrate) levels in postmenopausal women substituted with 17 beta-estradiol valerate and cyproterone acetate or medroxyprogesterone acetate, *J Clin Endocrinol Metab* 82:388, 1997.
1017. **Ylikorkala O, Cacciatore B, Paakkari I, Tikkanen MJ, Viinikka L, Toivonen J**, The long-term effects of oral and transdermal postmenopausal hormone replacement therapy on nitric oxide, endothelin-1, prostacyclin, and thromboxane, *Fertil Steril* 69:883, 1998.



1018. **Gilligan DM, Quyyumi AA, Cannon RO III**, Effects of physiological levels of estrogen on coronary vasomotor function in postmenopausal women, *Circulation* 89:2545, 1994.
1019. **Roqué M, Heras M, Roig E, Masotti M, Rigol M, Betriu A, Balasch J, Sanz G**, Short-term effects of transdermal estrogen replacement therapy on coronary vascular reactivity in postmenopausal women with angina pectoris and normal results on coronary angiograms, *J Am Coll Cardiol* 31:139, 1998.
1020. **Guetta V, Quyyumi AA, Prasad A, Panza JA, Waclawiw M, Cannon III RO**, The role of nitric oxide in coronary vascular effects of estrogen in postmenopausal women, *Circulation* 96:2795, 1997.
1021. **Williams JK, Shively CA, Clarkson TB**, Determinants of coronary artery reactivity in premenopausal female cynomolgus monkeys with diet-induced atherosclerosis, *Circulation* 90:983, 1994.
1022. **Chester AH, Jiang C, Borland JA, Yacoub M, Collins P**, Oestrogen relaxes human epicardial coronary arteries through non-endothelial-dependent mechanisms, *Coron Artery Dis* 6:417, 1995.
1023. **Collins P, Rosano GM, Jiang C, Lindsay D, Sarrel PM, Poole-Wilson PA**, Cardiovascular protection by estrogen—a calcium antagonism effect?, *Lancet* 341:264, 1993.
1024. **Pines A, Fishman EZ, Levo Y, Auerbuch M, Lidor A, Drory Y, Finkelstein A, Hetman-Peri M, Moshkowitz M, Ben-Ari E, Ayalon D**, The effects of hormone replacement therapy in normal postmenopausal women: measurements of Doppler-derived parameters of aortic flow, *Am J Obstet Gynecol* 164:806, 1991.
1025. **Pines A, Fishman EZ, Ayalon D, Drory Y, Averbuch M, Levo Y**, Long-term effects of hormone replacement therapy on Doppler-derived parameters of aortic flow in postmenopausal women, *Chest* 102:1496, 1992.
1026. **Voutilainen S, Hippelainen M, Hulklo S, Karppinen K, Ventila M, Kupri M**, Left ventricular diastolic function by Doppler echocardiography in relation to hormone replacement therapy in healthy postmenopausal women, *Am J Cardiol* 71:614, 1993.
1027. **Giraud GD, Morton MJ, Wilson RA, Burry KA, Speroff L**, Effects of estrogen and progestin on aortic size and compliance in postmenopausal women, *Am J Obstet Gynecol* 174:1708, 1996.
1028. **Prelevic GM, Beljic T**, The effect of oestrogen and progestogen replacement therapy on systolic flow velocity in healthy postmenopausal women, *Maturitas* 20:37, 1994.
1029. **Liang Y-L, Teede H, Shiel L, Thomas A, Craven R, Sachithanandan N, McNeil JJ, Cameron JD, Dart A, McGrath B**, Effects of oestrogen and progesterone on age-related changes in arteries of postmenopausal women, *Clin Exp Pharmacol Physiol* 24:457, 1997.
1030. **Pines A, Fisman EZ, Averbuch M, Drory Y, Motro M, Levo Y, Weiss A, Rotmensch H, Ayalon D**, The long-term effects of transdermal estradiol on left ventricular function and dimensions, *Eur J Menopause* 2:22, 1995.
1031. **Snabes MC, Payne JP, Kopelen HA, Dunn JK, Young RL, Zoghbi WA**, Physiologic estradiol replacement therapy and cardiac structure and function in normal postmenopausal women: a randomized, double-blind, placebo-controlled, crossover trial, *Obstet Gynecol* 89:332, 1997.
1032. **Poehlman ET, Goran MI, Gardner AW, Ades PA, Arciero PJ, Katzman-Rooks SM, Montgoverly SM, Toth MJ, Sutherland PT**, Determinants of decline in resting metabolic rate in aging females, *Am J Physiol* 264:E450, 1993.
1033. **Trémollières FA, Pouilles J-M, Ribot CA**, Relative influence of age and menopause on total and regional body composition changes in postmenopausal women, *Am J Obstet Gynecol* 175:1594, 1996.
1034. **Walton C, Godsland IF, Proudler A, Wynn V, Stevenson JC**, The effects of the menopause on insulin sensitivity, secretion and elimination in non-obese, healthy women, *Eur J Clin Invest* 23:466, 1993.
1035. **Proudler AJ, Godsland IF, Stevenson JC**, Insulin propeptides in conditions associated with insulin resistance in humans and their relevance to insulin measurements, *Metabolism* 43:46, 1994.
1036. **Haarbo J, Marslew U, Gotfredsen A, Christiansen C**, Postmenopausal hormone replacement therapy prevents central distribution of body fat after menopause, *Metabolism* 40:1323, 1991.
1037. **Ley C, Lees B, Stevenson J**, Sex- and menopause-associated changes in body-fat distribution, *Am J Clin Nutr* 55:950, 1992.
1038. **Reubinoff BE, Wurtman J, Rojansky N, Adler D, Stein P, Schenker JG, Brzezinski A**, Effects of

hormone replacement therapy on weight, body composition, fat distribution, and food intake in early postmenopausal women: a prospective study, *Fertil Steril* 64:963, 1995.

1039. **Gambacciani M, Ciaponi M, Cappagli B, Piaggese L, De Simone L, Orlandi R, Genazzani AR**, Body weight, body fat distribution, and hormonal replacement therapy in early postmenopausal women, *J Clin Endocrinol Metab* 82:414, 1997.
1040. **Chlebowski RT, Wactawski-Wende J, Ritenbaugh C, Hubbell FA, Ascensao J, Rodabough RJ, Rosenberg CA, Taylor VM, Harris R, Chen C, Adams-Campbell LL, White E; for the Women's Health Initiative Investigators**, Estrogen plus progestin and colorectal cancer in postmenopausal women, *N Engl J Med* 350:991, 2004.
1041. **Ferri C, Pittoni V, Piccoli A, Laurenti O, Cassone MR, Bellini C, Properzi G, Valesini G, De Mattia G, Santucci A**, Insulin stimulates endothelin-1 secretion from human endothelial cells and modulates its circulating levels in vivo, *J Clin Endocrinol Metab* 80:829, 1995.
1042. **Cagnacci A, Soldani R, Carriero PL, Paoletti AM, Fioretti P, Melis GB**, Effects of low doses of transdermal 17 beta-estradiol on carbohydrate metabolism in postmenopausal women, *J Clin Endocrinol Metab* 74:1396, 1992.
1043. **Lindheim S, Duffy D, Kojima T, Vijod M, Stanczyk F, Lobo R**, The route of administration influences the effect of estrogen on insulin sensitivity in postmenopausal women, *Fertil Steril* 62:1176, 1994.
1044. **Salomaa V, Rasi V, Pekkanen J, Vahtera E, Jauhiainen M, Vartiainen E, Ehnholm C, Tuomilehto J, Myllylä G**, Association of hormone replacement therapy with hemostatic and other cardiovascular risk factors: the FINRISK hemostasis study, *Arterioscler Thromb Vasc Biol* 15:1549, 1995.
1045. **Kanaya AM, Herrington D, Vittinghoff E, Lin F, Grady D, Bittner V, Cauley JA, Barrett-Conner E**, Glycemic effects of postmenopausal hormone therapy: the Heart and Estrogen/progestin Replacement Study. A randomized, double-blind, placebo-controlled study, *Ann Intern Med* 138:1, 2003.
1046. **Godsland IF, Ganger K, Walton C, Cust MP, Whitehead MI, Wynn V, Stevenson JC**, Insulin resistance, secretion, and elimination in postmenopausal women receiving oral or transdermal hormone replacement therapy, *Metabolism* 42:846, 1993.
1047. **Cucinelli F, Paparella P, Soranna L, Barini A, Cinque B, Mancuso S, Lanzone A**, Differential effect of transdermal estrogen plus progestagen replacement therapy on insulin metabolism in postmenopausal women: relation to their insulinemic secretion, *Eur J Endocrinol* 140:215, 1999.
1048. **Duncan AC, Lyall H, Roberts RN, Petrie JR, Perera MJ, Monaghan S, Hart DM, Connell JMC, Lumsden MA**, The effect of estradiol and a combined estradiol/progestagen preparation on insulin sensitivity in healthy postmenopausal women, *J Clin Endocrinol Metab* 84:2402, 1999.
1049. **Andersson B, Mattsson L, Hahn L, Mårin P, Lapidus L, Holm G, Bengtsson B, Björntorp P**, Estrogen replacement therapy decreases hyperandrogenicity and improves glucose homeostasis and plasma lipids in postmenopausal women with noninsulin-dependent diabetes mellitus, *J Clin Endocrinol Metab* 82:638, 1997.
1050. **Brussaard HE, Gevers Leuven JA, Frolich M, Kluft C, Krans HMJ**, Short-term oestrogen replacement therapy improves insulin resistance, lipids and fibrinolysis in postmenopausal women with NIDDM, *Diabetologia* 40:843, 1997.
1051. **Manson J, Rimm E, Colditz G, Willett W, Nathan D, Arky R, Roxner B, Hennekens C, Speizer F, Stampfer M**, A prospective study of postmenopausal estrogen therapy and subsequent incidence of non-insulin dependent diabetes mellitus, *Ann Epidemiol* 2:665, 1992.
1052. **Pentti K, Tuppurainen M, Honkanen R, Sandini L, Kröger H, Alhava E, Saarikoski S**, Hormone therapy protects from diabetes: the Kuopio Osteoporosis Risk Factor and Prevention Study, *Eur J Endocrinol* 160:979, 2009.
1053. **de Lauzon-Guillan B, Fournier A, Fabre A, Simon N, Mesrine S, Boutron-Ruault MC, Balkau B, Françoise C-C**, Menopausal hormone therapy and new-onset diabetes in the French Etude Epidemiologique de Femmes de la Mutuelle Générale de l'Education Nationale (E3N) cohort, *Diabetologia* 52:2092, 2009.
1054. **Bonds DE, Lasser N, Qi L, Brzyski RG, Caan B, Heiss G, Limacher MC, Liu JH, Mason E, Oberman A, O'Sullivan MJ, Phillips LS, Prineas RJ, Tinker L**, The effect on conjugated equine oestrogen on diabetes incidence: the Women's Health Initiative randomised trial, *Diabetologia* 49:459, 2006.

1055. **Rifici VA, Khachadurian AK**, The inhibition of low-density lipoprotein oxidation by 17-beta estradiol, *Metabolism* 41:1110, 1992.
1056. **Knopp R, Zhu X, Bonet B**, Effects of estrogens on lipoprotein metabolism and cardiovascular disease in women, *Atherosclerosis* 110(Suppl 1):S83, 1994.
1057. **Sack MN, Rader DJ, Cannon RO III**, Oestrogen and inhibition of oxidation of low-density lipoproteins in postmenopausal women, *Lancet* 343:269, 1994.
1058. **Keaney J Jr, Shwaery G, Xu A, Nicholosi R, Loscalzo J, Foxall T, Vita J**, 17 beta-estradiol preserves endothelial vasodilator function and limits low-density lipoprotein oxidation in hypercholesterolemic swine, *Circulation* 89:225, 1994.
1059. **Tranquilli AL, Mazzanti L, Cugini AM, Cester N, Garzetti GG, Romanini C**, Transdermal estradiol and medroxyprogesterone acetate in hormone replacement therapy are both antioxidants, *Gynecol Endocrinol* 9:137, 1995.
1060. **Samsioe G, Andersson K, Mattsson L-Å**, Relative fatty acid composition of serum lecithin in perimenopausal women using combined hormone replacement therapy, *Menopause* 4:193, 1997.
1061. **Meade TW, Dyer S, Howarth DJ, Imeson JD, Stirling Y**, Antithrombin III and procoagulant activity: sex differences and effects of the menopause, *Br J Haematol* 74:77, 1990.
1062. **Stefanick ML, Legault C, Tracy RP, Howard G, Kessler CM, Lucas DL, Bush TL**, Distribution and correlates of plasma fibrinogen in middle-aged women. Initial findings of the Postmenopausal Estrogen/Progestin Interventions (PEPI) Study, *Arterioscler Thromb Vasc Biol* 15:2085, 1995.
1063. **Meilahn E, Kuller L, Matthews K, Kiss J**, Hemostatic factors according to menopausal status and use of hormone replacement therapy, *Ann Epidemiol* 2:445, 1992.
1064. **Scarabin PY, Flu-Bureau G, Bara L, Bonithon-Kopp C, Guize L, Samama M**, Haemostatic variables and menopausal status: influence of hormone replacement therapy, *Thromb Haemost* 70:584, 1994.
1065. **Gebara OCE, Mittleman MA, Sutherland P, Lipinska I, Matheney T, Xu P, Welty FK, Wilson PW, Levy D, Muller JE, Tofler GH**, Association between increased estrogen status and increased fibrinolytic potential in the Framingham Offspring Study, *Circulation* 91:1952, 1995.
1066. **Conard J, Gompel A, Pelissier C, Mirabel C, Basdevant A**, Fibrinogen and plasminogen modifications during oral estradiol replacement therapy, *Fertil Steril* 68:449, 1997.
1067. **Demirel A, Baykal C, Kirazli S, Ayhan A**, Effects of hormone replacement on hemostasis in spontaneous menopause, *Menopause* 8:135, 2001.
1068. **De Souza MJ, Nulsen JC, Sequenzia LC, Bona RD, Walker FJ, Luciano AA**, The effect of medroxyprogesterone acetate on conjugated equine estrogen-induced changes in coagulation parameters in postmenopausal women, *J Womens Health* 5:121, 1996.
1069. **Bonduki CE, Lourenço DM, Baracat E, Haidar M, Noguti MAE, da Motta ELA, Lima GR**, Effect of estrogen-progestin hormonal replacement therapy on plasma antithrombin III of postmenopausal women, *Acta Obstet Gynecol Scand* 77:330, 1998.
1070. **Meilahn E, Cauley J, Tracy R, Macy E, Gutai J, Kuller L**, Association of sex hormones and adiposity with plasma levels of fibrinogen and PAI-1 in postmenopausal women, *Am J Epidemiol* 143:159, 1996.
1071. **Koh KK, Mincemoyer R, Bui MN, Csako G, Pucino F, Guetto V, Waclawiw M, Cannon RO III**, Effects of hormone-replacement therapy on fibrinolysis in postmenopausal women, *N Engl J Med* 336:683, 1997.
1072. **Boschetti C, Corteliaro M, Nencioni T, Bertolli V, Della Volpe A, Zanussi C**, Short- and long-term effects of hormone replacement therapy (transdermal estradiol vs oral conjugated equine estrogens, combined with medroxyprogesterone acetate) on blood coagulation factors in postmenopausal women, *Thromb Res* 62:1, 1991.
1073. **Saleh AA, Dorey LG, Dombrowski MP, Ginsburg KA, Hirokawa S, Kowalczyk C, Hirata J, Bottoms S, Cotton DB, Mammen EF**, Thrombosis and hormone replacement therapy in postmenopausal women, *Am J Obstet Gynecol* 169:1554, 1993.
1074. **Scarabin PY, Hemker HC, Clement C, Soisson V, Alhenc-Gelas M**, Increased thrombin generation among postmenopausal women using hormone therapy: importance of the route of estrogen administration and

progestogens, *Menopause* 18:873, 2011.

1075. **Pabinger I, Ay C**, Biomarkers and venous thromboembolism, *Arterioscler Thromb Vasc Biol* 29:332, 2009
1076. **Canonico M, Plu-Bureau G, Lowe GD, Scarabin PY**, Hormone replacement therapy and risk of venous thromboembolism in postmenopausal women: systematic review and meta-analysis, *Br Med J* 336:1227, 2008.
1077. **Kessler CM, Szymanski LM, Shamsipour Z, Muesing RA, Miller VT, Larosa JC**, Estrogen replacement therapy and coagulation: relationship to lipid and lipoprotein changes, *Obstet Gynecol* 89:325, 1997.
1078. **Bladbjerg EM, Madsen JS, Kristensen SR, Abrahamsen B, Brixen K, Mosekilde L, Jespersen J**, Effect of long-term hormone replacement therapy on tissue factor pathway inhibitor and thrombin activatable fibrinolysis inhibitor in healthy postmenopausal women: a randomized controlled study, *J Thromb Haemost* 1:1208, 2003.
1079. **Wakatsuki A, Ikenouse N, Shinohara K, Watanabe K, Fukaya T**, Different effects of oral and transdermal estrogen replacement therapy on matrix metalloproteinase and their inhibitor in postmenopausal women, *Arterioscler Thromb Vasc Biol* 23:1948, 2003.
1080. **Suzuki A, Mizuno K, Ino Y, Okada M, Kikkawa F, Mizutani S, Tomoda Y**, Effects of 17 beta-estradiol and progesterone on growth-factor-induced proliferation and migration in human female aortic smooth muscle cells in vitro, *Cardiovasc Res* 32:516, 1996.
1081. **Okada M, Suzuki A, Mizuno K, Asada Y, Kuwayama T, Tamakoshi K, Mizutani S, Tomoda Y**, Effects of 17 beta-estradiol and progesterone on migration of human monocytic THP-1 cells stimulated by minimally oxidized low-density lipoprotein in vitro, *Cardiovasc Res* 34:529, 1997.
1082. **Dubey RK, Jackson EK, Luscher TF**, Nitric oxide inhibits angiotensin II-induced migration of rat aortic smooth muscle cell. Role of cyclic-nucleotides and angiotensin 1 receptors, *J Clin Invest* 96:141, 1995.
1083. **Espeland MA, Applegate W, Furberg CD, Lefkowitz D, Rice L, Hunninghake D; the ACAPS Investigators**, Estrogen replacement therapy and progression of intimal-medial thickness in the carotid arteries of postmenopausal women, *Am J Epidemiol* 142:1011, 1995.
1084. **Baron YM, Galea MB**, Carotid artery wall thickness in women treated with hormone replacement therapy, *Maturitas* 27:47, 1997.
1085. **Jonas HA, Kronmal RA, Psaty BM, Manolio TA, Meilahn EN, Tell GS, Tracy RP, Robbins JA, Anton-Culver H; for the CHS Collaborative Research Group**, Current estrogen-progestin and estrogen replacement therapy in elderly women: association with carotid atherosclerosis, *Ann Epidemiol* 6:314, 1996.
1086. **Akkad A, Hartshorne T, Bell PRF, Al-Azzawi F**, Carotid plaque regression on oestrogen replacement: a pilot study, *Eur J Vasc Endovasc Surg* 11:347, 1996.
1087. **Krasinski K, Spyridopoulos I, Asahara T, van der Zee R, Isner JM, Losordo DW**, Estradiol accelerates functional endothelial recovery after arterial injury, *Circulation* 95:1768, 1997.
1088. **Spyridopoulos I, Sullivan AB, Kearney M, Isner JM, Losordo DW**, Estrogen-receptor-mediated inhibition of human endothelial cell apoptosis. Estradiol as a survival factor, *Circulation* 95:1505, 1997.
1089. **Levine RL, Chen SJ, Durand J, Chen YF, Oparil S**, Medroxyprogesterone attenuates estrogen-mediated inhibition of neointima formation after balloon injury of the rat carotid artery, *Circulation* 94:2221, 1996.
1090. **Frazier-Jessen MR, Kovacs EJ**, Estrogen modulation of JE/monocyte chemoattractant protein-1 mRNA expression in murine macrophages, *J Immunol* 154:1838, 1995.
1091. **Proudler AJ, Ahmed AI, Crook D, Fogelman I, Rymer JM, Stevenson JC**, Hormone replacement therapy and serum angiotensin-converting-enzyme activity in postmenopausal women, *Lancet* 346:89, 1995.
1092. **Schunkert H, Danser AH, Hense HW, Derkx FH, Kurzinger S, Riegger GA**, Effects of estrogen replacement therapy on the renin-angiotensinogen system in postmenopausal women, *Circulation* 95:39, 1997.
1093. **Nickenig G, Bäumer AT, Grohè C, Kahlert S, Strehlow K, Rosenkranz S, Stäblein A, Beckers F, Smits JFM, Daemen MJAP, Vetter H, Böhm M**, Estrogen modulates AT1 receptor gene expression in vitro and in vivo, *Circulation* 97:2197, 1998.
1094. **Nickenig G, Jung O, Strehlow K, Zolk O, Linz W, Schölkens BA, Böhm M**, Hypercholesterolemia is associated with enhanced angiotensin AT1-receptor expression, *Am J Physiol* 272(6 Pt 2):H2701, 1997.
1095. **Jilma B, Hildebrandt J, Kapiotis S, Wagner O, Kitzweger E, Müllner C, Monitzer B, Krejcy K, Eichler H-G**, Effects of estradiol on circulating P-selectin, *J Clin Endocrinol Metab* 81:2350, 1996.

1096. **Farzati A, Esposito K, Colacurci N, Fornaro F, Chiantera V, Barzati B**, Effects of transdermal hormone replacement therapy on levels of soluble P- and E-selectin in postmenopausal healthy women, *Fertil Steril* 77:476, 2002.
1097. **Hak AE, Polderman KH, Westendorp IC, Jakobs C, Hofman A, Witteman JC, Stehouwer CD**, Increased plasma homocysteine after menopause, *Atherosclerosis* 149:163, 2000.
1098. **Hak AE, Bak AA, Lindemans J, Planellas J, Coelingh Benink HJ, Hofman A, Grobbee DE, Witteman JC**, The effect of hormone replacement therapy on serum homocysteine levels in perimenopausal women: a randomized controlled trial, *Atherosclerosis* 158:437, 2001.
1099. **Chiantera V, Sarti CD, Fornaro F, Farzati A, De Franciscis P, Sepe E, Borrelli AL, Colacurci N**, Long-term effects of oral and transdermal hormone replacement therapy on plasma homocysteine levels, *Menopause* 10:286, 2003.
1100. **Rosenberg L, Armstrong B, Jick H**, Myocardial infarction and estrogen therapy in postmenopausal women, *N Engl J Med* 294:1256, 1976.
1101. **Pfeffer RI, Whipple GH, Kurosake TT, Chapman JM**, Coronary risk and estrogen use in postmenopausal women, *Am J Epidemiol* 107:479, 1978.
1102. **Jick H, Dinan B, Rothman KJ**, Noncontraceptive estrogens and non-fatal myocardial infarction, *JAMA* 239:1407, 1978.
1103. **Rosenberg L, Sloane D, Shapiro S, Kaufman D, Stolley PD, Miethinen OS**, Noncontraceptive estrogens and myocardial infarction in young women, *JAMA* 224:339, 1980.
1104. **Ross RK, Paganini-Hill A, Mack TM, Arthur M, Henderson BE**, Menopausal oestrogen therapy and protection from death from ischaemic heart disease, *Lancet* 1:858, 1981.
1105. **Bain C, Willett W, Hennekens CH, Rosner B, Belanger C, Speizer FE**, Use of postmenopausal hormones and risk of myocardial infarction, *Circulation* 64:42, 1981.
1106. **Adam S, Williams V, Vessey MP**, Cardiovascular disease and hormone replacement treatment: a pilot case-control study, *Br Med J* 282:1277, 1981.
1107. **Szklo M, Tonascia J, Gordis L, Bloom I**, Estrogen use and myocardial infarction risk: a case-control study, *Prev Med* 13:510, 1984.
1108. **Sullivan JM, Vander Zwaag R, Lemp GF, Hughes JP, Maddock V, Kroetz FW, Ramanathan KB, Mirvis DM**, Postmenopausal estrogen use and coronary atherosclerosis, *Ann Intern Med* 108:358, 1988.
1109. **Gruchow HW, Anderson AJ, Barboriak JJ, Sobocinski KA**, Postmenopausal use of estrogen and occlusion of coronary arteries, *Am Heart J* 115:954, 1988.
1110. **McFarland K, Boniface M, Hornung C, Earnhardt W, Humphries J**, Risk factors and noncontraceptive estrogen use in women with and without coronary disease, *Am Heart J* 117:1209, 1989.
1111. **Hong MG, Romm PA, Reagan K, Green CE, Rackley CE**, Effects of estrogen replacement therapy on serum lipid values and angiographically defined coronary artery disease in postmenopausal women, *Am J Cardiol* 69:176, 1992.
1112. **Psaty BM, Heckbart SR, Atkins D, Lemaitre R, Koepsell TD, Wahl PN, Siscovick DS, Wagner EH**, The risk of myocardial infarction associated with the combined use of estrogens and progestins in postmenopausal women, *Arch Intern Med* 154:1333, 1994.
1113. **Beard CM, Kottke TE, Annegers JF, Ballard DJ**, The Rochester Coronary Heart Disease Project: effect of cigarette smoking, hypertension, diabetes, and steroidal estrogen use on coronary heart disease among 40- to 59-year-old women, 1960 through 1982, *Mayo Clin Proc* 64:1471, 1989.
1114. **Newton KM, LaCroix AZ, McKnight B, Knopp RH, Siscovick DS, Heckbert SR, Weiss NS**, Estrogen replacement therapy and prognosis after first myocardial infarction, *Am J Epidemiol* 145:269, 1997.
1115. **Heckbert SR, Weiss NS, Koepsell TD, Lemaitre RN, Smith NL, Siscovick DS, Lin D, Psaty BM**, Duration of estrogen replacement therapy in relation to the risk of incident myocardial infarction in postmenopausal women, *Arch Intern Med* 157:1330, 1997.
1116. **Váras-Lorenzo C, García-Rodríguez LA, Perez-Gutthann S, Duque-Oliart A**, Hormone replacement therapy and incidence of acute myocardial infarction. A population-based nested case-control study, *Circulation* 101:2572, 2000.

1117. **Rodriguez C, Calle EE, Patel AV, Tatham LM, Jacobs EJ, Thun MJ**, Effect of body mass on the association between estrogen replacement therapy and mortality among elderly US women, *Am J Epidemiol* 153:145, 2001.
1118. **Shlipak MG, Angeja BG, Go AS, Frederick PD, Canto JG, Grady D**; for the **National Registry of Myocardial Infarction-3 Investigators**, Hormone therapy and in-hospital survival after myocardial infarction in postmenopausal women, *Circulation* 104:2300, 2001.
1119. **Reis SE, Holubkov R, Young JB, White BG, Cohn JN, Feldman AM**, Estrogen is associated with improved survival in aging women with congestive heart failure: analysis of the vesnarinone studies, *J Am Coll Cardiol* 36:529, 2000.
1120. **Westendorp ICD, in't Veld BA, Grobbee DE, Pols HAP, Meijer WT, Hofman A, Witteman JCM**, Hormone replacement therapy and peripheral arterial disease. The Rotterdam Study, *Arch Intern Med* 160:2498, 2000.
1121. **Burch JC, Byrd BF, Vaughn WK**, The effects of long-term estrogen on hysterectomized women, *Am J Obstet Gynecol* 118:778, 1974.
1122. **Gordon T, Kannel WB, Hjortland MC, McNamara PM**, Menopause and coronary heart disease: the Framingham Study, *Ann Intern Med* 89:37, 1978.
1123. **Hammond CB, Jelovsek FR, Lee KL, Creasman WT, Parker RT**, Effects of long-term estrogen replacement therapy: I. Metabolic effects, *Am J Obstet Gynecol* 133:525, 1979.
1124. **Wilson PWF, Garrison RJ, Castelli WP**, Postmenopausal estrogen use, cigarette smoking, and cardiovascular morbidity in women over 50, *N Engl J Med* 313:1038, 1985.
1125. **Bush TL, Barrett-Connor E, Cowan DK, Criqui MH, Wallace RB, Suchindran CM, Tyroler HA, Rifkind BM**, Cardiovascular mortality and noncontraceptive use of estrogen in women: results from the Lipid Research Clinics Program Follow-up Study, *Circulation* 75:1102, 1987.
1126. **Criqui MH, Suarez L, Barrett-Connor E, McPhillips J, Wingard DL, Garland C**, Postmenopausal estrogen use and mortality, *Am J Epidemiol* 128:606, 1988.
1127. **Henderson BE, Paganini-Hill A, Ross RK**, Estrogen replacement therapy and protection from acute myocardial infarction, *Am J Obstet Gynecol* 159:312, 1988.
1128. **Perlman J, Wolff P, Finucane F, Madans J**, Menopause and the epidemiology of cardiovascular disease in women, *Prog Clin Biol Res* 320:283, 1989.
1129. **Lafferty FW, Fiske ME**, Postmenopausal estrogen replacement: a long-term cohort study, *Am J Med* 97:66, 1994.
1130. **Folsom AR, Mink PJ, Sellers TA, Hong C-P, Zheng W, Potter JD**, Hormonal replacement therapy and morbidity and mortality in a prospective study of postmenopausal women, *Am J Public Health* 85:1128, 1995.
1131. **Grodstein F, Stampfer MJ, Manson JE, Colditz GA, Willett WC, Rosner B, Speizer FE, Hennekens CH**, Postmenopausal estrogen and progestin use and risk of cardiovascular disease, *N Engl J Med* 335:453, 1996.
1132. **Grodstein F, Stampfer MJ, Colditz GA, Willett WC, Manson JE, Joffe M, Rosner B, Fuchs C, Hankinson SE, Hunter DJ, Hennekens CH, Speizer FE**, Postmenopausal hormone therapy and mortality, *N Engl J Med* 336:1769, 1997.
1133. **Petitti DB, Perlman JA, Sidney S**, Noncontraceptive estrogens and mortality: long-term follow-up of women in the Walnut Creek Study, *Obstet Gynecol* 70:289, 1987.
1134. **Ettinger B, Friedman GD, Bush T, Quesenberry CP Jr**, Reduced mortality associated with long-term postmenopausal estrogen therapy, *Obstet Gynecol* 87:5, 1996.
1135. **Schairer C, Adami H-O, Hoover R, Persson I**, Cause-specific mortality in women receiving hormone replacement therapy, *Epidemiology* 8:59, 1997.
1136. **Løkkegaard E, Andreassen AH, Jacobsen RK, Nielsen LH, Agger C, Lidegaard Ø**, Hormone therapy and risk of myocardial infarction: a national register study, *Eur Heart J* 29:2660, 2008.
1137. **Grodstein F, Manson JE, Colditz GA, Willett WC, Speizer FE, Stampfer MJ**, A prospective, observational study of postmenopausal hormone therapy and primary prevention of cardiovascular disease, *Ann Intern Med* 133:933, 2000.

1138. **McLaughlin VV, Hoff JA, Rich S**, Relation between hormone replacement therapy in women and coronary artery disease estimated by electron beam tomography, *Am Heart J* 134:1115, 1997.
1139. **Christian RC, Harrington S, Edwards WD, Oberg AL, Fitzpatrick LA**, Estrogen status correlates with the calcium content of coronary atherosclerotic plaques in women, *J Clin Endocrinol Metab* 87:1062, 2002.
1140. **Akhrass F, Evans AT, Wang Y, Rich S, Kannan CR, Fogelfeld L, Mazzone T**, Hormone replacement therapy is associated with less coronary atherosclerosis in postmenopausal women, *J Clin Endocrinol Metab* 88:5611, 2003.
1141. **Manson JE, Allison MA, Rossouw JE, Carr JJ, Langer RD, Hsia J, Kuller LH, Cochrane BB, Hunt JR, Ludlam SE, Pettinger MB, Gass M, Mrgolis KL, Nathan L, Ockene JK, Prentice RL, Robbins J, Stefanick ML; for the WHI and WHI-CACS Investigators**, Estrogen therapy and coronary-artery calcification, *N Engl J Med* 356:2591, 2007.
1142. **Matthews KA, Kuller LH, Wing RR, Meilahn EN, Plantinga P**, Prior to use of estrogen replacement therapy, are users healthier than nonusers?, *Am J Epidemiol* 143:971, 1997.
1143. **Henderson BE, Paganini-Hill A, Ross RK**, Decreased mortality in users of estrogen replacement therapy, *Arch Intern Med* 151:75, 1991.
1144. **Stampfer MJ, Colditz GA, Willett WC, Manson JE, Rosner B, Speizer FE, Hennekens CH**, Postmenopausal estrogen therapy and cardiovascular disease: ten-year follow-up from the Nurses' Health Study, *N Engl J Med* 325:756, 1991.
1145. **Derby CA, Hume AL, McPhillips JB, Barbour MM, Carleton RA**, Prior and current health characteristics of postmenopausal estrogen replacement therapy users compared to non-users, *Am J Obstet Gynecol* 173:544, 1995.
1146. **MacLennan AH, Wilson DH, Taylor AW**, Hormone replacement therapy: prevalence, compliance and the 'healthy women' notion, *Climacteric* 1:42, 1998.
1147. **Blumel JE, Castelo-Branco C, Roncagliolo ME, Guanes PP, Lavin P**, Do women using hormone replacement treatment have less pre-existing cardiovascular risk, *Maturitas* 38:315, 2001.
1148. **Petitti DB, Wingerd J, Pellegrin F, Ramcharan S**, Risk of vascular disease in women: smoking, oral contraceptives, non-contraceptive estrogens, and other factors, *JAMA* 242:1150, 1979.
1149. **Paganini-Hill A, Ross RK, Henderson BE**, Postmenopausal oestrogen treatment and stroke: a prospective study, *Br Med J* 297:519, 1988.
1150. **Thompson SG, Meade TW, Greenberg G**, The use of hormonal replacement therapy and the risk of stroke and myocardial infarction in women, *J Epidemiol Community Health* 43:173, 1989.
1151. **Hunt K, Vessey M, McPherson K**, Mortality in a cohort of long-term users of hormone replacement therapy: an updated analysis, *Br J Obstet Gynaecol* 97:1080, 1990.
1152. **Finucane FF, Mardans JH, Bush TL, Wolf PH, Kleinman JC**, Decreased risk of stroke among postmenopausal hormone users, *Arch Intern Med* 153:73, 1993.
1153. **Falkeborn M, Persson I, Terent A, Adami HO, Lithell H, Bergstrom R**, Hormone replacement therapy and the risk of stroke. Follow-up of a population-based cohort in Sweden, *Arch Intern Med* 153:1201, 1993.
1154. **Longstreth WT Jr, Nelson LM, Koepsell TD, van Belle G**, Subarachnoid hemorrhage and hormonal factors in women: a population-based case-control study, *Ann Intern Med* 121:168, 1994.
1155. **Pedersen AT, Lidegaard Ø, Kreiner S, Ottesen B**, Hormone replacement therapy and risk of non-fatal stroke, *Lancet* 350:1277, 1997.
1156. **Petitti DB, Sidney S, Quesenberry CP Jr, Bernstein A**, Ischemic stroke and use of estrogen and estrogen/progestogen as hormone replacement therapy, *Stroke* 29:23, 1998.
1157. **Lemaitre RN, Heckbert SR, Psaty BM, Smith NL, Kaplan RC, Longstreth WT Jr**, Hormone replacement therapy and associated risk of stroke in postmenopausal women, *Arch Intern Med* 162:1954, 2002.
1158. **Lökkegaard E, Jovanovic Z, Heitmann BL, Keiding N, Ottesen B, Hundrup YA, Obel EB, Pedersen AT**, Increased risk of stroke in hypertensive women using hormone therapy. Analyses based on the Danish Nurse Study, *Arch Neurol* 60:1379, 2003.
1159. **Li C, Engström G, Hedblad B, Berglund G, Janzon L**, Risk of stroke and hormone replacement therapy. A prospective cohort study, *Maturitas* 54:11, 2006.

1160. **Lind T, Cameron EC, Hunter WM, Leon C, Moran PF, Oxley A, Gerrard J, Lind UCG**, A prospective, controlled trial of six forms of hormone replacement therapy given to postmenopausal women, *Br J Obstet Gynaecol* 86(Suppl 3):1, 1979.
1161. **Pfeffer RI, Kurosaki TT, Charlton SK**, Estrogen use and blood pressure in later life, *Am J Epidemiol* 110:469, 1979.
1162. **Lutola H**, Blood pressure and hemodynamics in postmenopausal women during estradiol-17 substitution, *Ann Clin Res* 15(Suppl 38):9, 1983.
1163. **Wren BG, Routledge AD**, The effect of type and dose of oestrogen on the blood pressure of postmenopausal women, *Maturitas* 5:135, 1983.
1164. **Hassager C, Christiansen C**, Blood pressure during oestrogen/progestogen substitution therapy in healthy post-menopausal women, *Maturitas* 9:315, 1988.
1165. **Seely EW, Walsh BW, Gerhard MD, Williams GH**, Estradiol with or without progesterone and ambulatory blood pressure in postmenopausal women, *Hypertension* 33:1190, 1999.
1166. **Lip GY, Beevers M, Churchill D, Beevers DG**, Hormone replacement therapy and blood pressure in hypertensive women, *J Hum Hypertens* 8:491, 1994.
1167. **Sands RH, Studd JWW, Crook D, Warren JB, Cruickshank J, Coats A**, The effect of estrogen on blood pressure in hypertensive postmenopausal women, *Menopause* 4:115, 1997.
1168. **Kornhauser C, Malacara JM, Gray ME, Perez-Luque EL**, The effect of hormone replacement therapy on blood pressure and cardiovascular risk factors in menopausal women with moderate hypertension, *J Hum Hypertens* 11:405, 1997.
1169. **Mercuro G, Zoncu S, Piano D, Pilia I, Lao A, Melis GB, Cherchi A**, Estradiol-17beta reduces blood pressure and restores the normal amplitude of the circadian blood pressure rhythm in postmenopausal hypertension, *Am J Hypertens* 11:909, 1998.
1170. **Szekacs B, Vajo Z, Acs N, Hada P, Csuzi L, Bezeredi J, Magyar Z, Brinton EA**, Hormone replacement therapy reduces mean 24-hour blood pressure and its variability in postmenopausal women with treated hypertension, *Menopause* 7:31, 2000.
1171. **Affinito P, Palomba S, Bonifacio M, Fontana D, Izzo R, Trimarco B, Nappi C**, Effects of hormonal replacement therapy in postmenopausal hypertensive patients, *Maturitas* 40:75, 2001.
1172. **Medical Research Council's General Practice Research Framework**, Randomised comparison of oestrogen versus oestrogen plus progestogen hormone replacement therapy in women with hysterectomy, *Br Med J* 312:473, 1996.
1173. **Zarifis J, Lip GYH, Beevers DG**, Effects of discontinuing hormone replacement therapy in patients with uncontrolled hypertension, *Am J Hypertens* 8:1241, 1995.
1174. **Mercuro G, Zoncu S, Pilia I, Lao A, Melis GB, Cherchi A**, Effects of acute administration of transdermal estrogen on postmenopausal women with systemic hypertension, *Am J Cardiol* 80:652, 1997.
1175. **Bérard A, Kahn SR, Abenhaim L**, Is hormone replacement therapy protective for venous ulcer of the lower limbs?, *Pharmacoevidemol Drug Saf* 10:245, 2001.
1176. **Margolis DJ, Knauss J, Bilker W**, Hormone replacement therapy and prevention of pressure ulcers and venous leg ulcers, *Lancet* 359:675, 2002.
1177. **The Women's Health Initiative Study Group**, Design of the Women's Health Initiative clinical trial and observational study, *Control Clin Trials* 19:61, 1998.
1178. **Rossouw JE, Anderson GL, Prentice RL, LaCroix AZ, Kooperberg CL, Stefanick ML, Jackson RD, Beresford SA, Howard BV, Johnson KC, Kotchen JM, Ockene J; Writing Group for the Women's Health Initiative Investigators**, Risks and benefits of estrogen plus progestin in healthy postmenopausal women. Principal results from the Women's Health Initiative randomized controlled trial, *JAMA* 288:321, 2002.
1179. **The Women's Health Initiative Steering Committee**, Effects of conjugated equine estrogen in postmenopausal women with hysterectomy. The Women's Health Initiative Randomized Controlled Trial, *JAMA* 291:1707, 2004.
1180. **Stefanick ML, Cochrane BB, Hsia J, Barad DH, Liu JH, Johnson SR**, The Women's Health Initiative postmenopausal hormone trials: overview and baseline characteristics of participants, *Ann Epidemiol* 13:S78,



2003.

1181. **Manson JE, Hsia J, Johnson KC, Rossouw JE, Assaf AR, Lasser NL, Trevisan M, Black HR, Heckbert SR, Detrano R, Strickland OL, Wong ND, Crouse JR, Stein E, Cushman M;** for the **Women's Health Initiative Investigators**, Estrogen plus progestin and the risk of coronary heart disease, *N Engl J Med* 349:523, 2003.
1182. **Chilvers CE, Knibb RC, Armstrong SJ, Woods KL, Logan RF**, Post menopausal hormone replacement therapy and risk of acute myocardial infarction—a case control study of women in the East Midlands, UK, *Eur Heart J* 24:2197, 2003.
1183. **Toh S, Hernández-Díaz S, Logan RF, Rossouw JE, Hernán MA**, Coronary heart disease in postmenopausal recipients of estrogen plus progestin therapy: does the increased risk ever disappear? A randomized trial, *Ann Intern Med* 152:211, 2010.
1184. **Appt S, Clarkson TB, Lees CJ, Anthony MS**, Low dose estrogens inhibit coronary artery atherosclerosis in postmenopausal monkeys, *Maturitas* 55:187, 2006.
1185. **Wassertheil-Smoller S, Hendrix SL, Limacher M, Heiss G, Kooperberg C, Baird A, Kotchen T, Curb JD, Black H, Rossouw JE, Aragaki A, Safford M, Stein E, Laowattana S, Mysiw WJ;** for the **WHI Investigators**, Effect of estrogen plus progestin on stroke in postmenopausal women. The Women's Health Initiative: a randomized trial, *JAMA* 289:2673, 2003.
1186. **Hendrix SL, Wassertheil-Smoller S, Johnson KC, Howard BV, Kooperberg C, Rossouw JE, Trevisan M, Aragaki A, Baird AE, Bray PF, Buring JE, Criqui MH, Herrington D, Lynch JK, Rapp SR, Torner J;** for the **WHI Investigators**, Effects of conjugated equine estrogen on stroke in the Women's Health Initiative, *Circulation* 113:2425, 2006.
1187. **Viscoli CM, Brass LM, Kernan WN, Sarrel PM, Suissa S, Horwitz RL**, A clinical trial of estrogen-replacement therapy after ischemic stroke, *N Engl J Med* 345:1243, 2001.
1188. **Grodstein F, Manson JE, Stampfer MJ, Rexrode K**, Postmenopausal hormone therapy and stroke. Role of time since menopause and age at initiation of hormone therapy, *Arch Intern Med* 168:861, 2008.
1189. **Rossouw JE, Prentice RL, Manson JE, LieLing W, Barad D, Barnabei VM, Ko M, LaCroix AZ, Margolis KL, Stefanick ML**, Postmenopausal hormone therapy and risk of cardiovascular disease by age and years since menopause, *JAMA* 297:1465, 2007.
1190. **Hulley S, Grady D, Bush T, Furberg C, Herrington D, Riggs B, Vittinghoff E;** for the **Heart and Estrogen/progestin Replacement Study (HERS) Research Group**, Randomized trial of estrogen plus progestin for secondary prevention of coronary heart disease in postmenopausal women, *JAMA* 280:605, 1998.
1191. **Grady D, Herrington D, Bittner V, Blumenthal R, Davidson M, Hlatky M, Hsia J, Hulley SB, Herd A, Khan S, Newby LK, Waters D, Vittinghoff E, Wenger N**, Heart and Estrogen/progestin Replacement Study Follow-up (HERS II): 1. Cardiovascular outcomes during 6.8 years of hormone therapy, *JAMA* 288:49, 2002.
1192. **Hulley S, Furberg C, Barrett-Connor E, Cauley J, Grady D, Haskell W, Knopp R, Lowery M, Satterfield S, Schrott H, Vittinghoff E, Hunninghake D**, Heart and Estrogen/progestin Replacement Study Follow-up (HERS II): 2. Non-cardiovascular disease outcomes during 6.8 years of hormone therapy, *JAMA* 288:58, 2002.
1193. **Hodis HN, Mack WJ, Lobo RA, Shoupe D, Sevanian A, Mahrer PR, Selzer RH, Liu CC, Liu CC, Azen SP**, Estrogen in the prevention of atherosclerosis: a randomized, double-blind, placebo-controlled trial, *Ann Intern Med* 135:939, 2001.
1194. **Herrington DM, Reboussin DM, Brosnihan KB, Sharp PC, Shumaker SA, Snyder TE, Furberg CD, Kowalchuk GJ, Stuckey TD, Rogers WJ, Givens DH, Waters D**, Effects of estrogen replacement on the progression of coronary-artery atherosclerosis, *N Engl J Med* 343:522, 2000.
1195. **Hodis HN, Mack WJ, Azen SP, Lobo RA, Shoupe D, Mahrer PR, Faxon DP, Cashin-Hemphill L, Sanmarco M, French WJ, Shook TL, Gaaarder TD, Mehra AO, Rabbani R, Sevanian A, Shil AB, Torres M, Vogelbach KH, Selzer RH;** for the **Women's Estrogen-Progestin Lipid-Lowering Hormone Atherosclerosis Regression Trial Research Group**, Hormone therapy and the progression of coronary-artery atherosclerosis in postmenopausal women, *N Engl J Med* 349:535, 2003.

1196. **Clarke SC, Kelleher J, Lloyd-Jones H, Slack M, Schofield PM**, A study of hormone replacement therapy in postmenopausal women with ischaemic heart disease: the Papworth HRT Atherosclerosis Study, *Br J Obstet Gynaecol* 109:1056, 2002.
1197. **Waters DD, Alderman EL, Hsia J, Howard BV, Cobb FR, Rogers WJ, Ouyang P, Thompson P, Tardif JC, Higginson L, Bittner V, Steffes M, Gordon DJ, Proschan M, Younes N, Verter JI**, Effects of hormone replacement therapy and antioxidant vitamins supplements on coronary atherosclerosis in postmenopausal women. A randomized controlled trial, *JAMA* 288:2432, 2002.
1198. **The ESPRIT Team**, Oestrogen therapy for prevention of reinfarction in postmenopausal women: a randomised placebo controlled trial, *Lancet* 360:2001, 2002.
1199. **Hsia J, Langer RD, Manson JE, Kuller L, Johnson KC, Hendrix SL, Pettinger M, Hechbert SR, Greep N, Crawford S, Eaton CB, Kostis JB, Cralis P, Prentice R; for the Women's Health Initiative Investigators**, Conjugated equine estrogens and coronary heart disease. The Women's Health Initiative, *Arch Intern Med* 166:357, 2006.
1200. **Salpeter SR, Cheng J, Thabane L, Buckley NS, Salpeter EE**, Bayesian meta-analysis of hormone therapy and mortality in younger postmenopausal women, *Am J Med* 122:1016, 2009.
1201. **de Kleijn MJ, Bots ML, Bak AA, Westendorp IC, Planellas J, Coelingh Bennink H, Witteman JC, Grobbee DE**, Hormone replacement therapy in perimenopausal women and 2-year change of carotid intima-media thickness, *Maturitas* 32:195, 1999.
1202. **Angerer P, Störk S, Kothny W, Schmitt P, von Schacky C**, Effect of oral postmenopausal hormone replacement on progression of atherosclerosis. A randomized, controlled trial, *Atheros Thromb Vasc Biol* 21:262, 2001.
1203. **Allison MA, Manson JE, Langer RD, Carr JJ, Rossouw JE, Pettinger MB, Phillips L, Cochrane BB, Eaton CB, Greenland P, Hendrix S, Hsia J, Hunt JR, Jackson RD, Johnson KC, Kuller LH, Robinson J; Women's Health Initiative and Women's Health Initiative Coronary Artery Calcium Study Investigators**, Oophorectomy, hormone therapy, and subclinical coronary artery disease in women with hysterectomy: the Women's Health Initiative coronary artery calcium study, *Menopause* 15:639, 2008.
1204. **Speroff L**, Gonads are the heart of the matter, *Menopause* 14:385, 2007.
1205. **Rivera CM, Grossardt BR, Rhodes DJ, Rocca WA**, Increased mortality for neurological and mental diseases following early bilateral oophorectomy, *Neuroepidemiology* 33:32, 2009.
1206. **Rivera CM, Grossardt BR, Rhodes DJ, Brown RD Jr, Roger VL, Melton LJ III, Rocca WA**, Increased cardiovascular mortality after early bilateral oophorectomy, *Menopause* 16:15, 2009.
1207. **Rocca WA, Bower JH, Maraganore DM, Ahiskog JE, Grossardt BR, de Andrade M, Melton LJ III**, Increased risk of parkinsonism in women who underwent oophorectomy before menopause, *Neurology* 70:200, 2008.
1208. **Rocca WA, Grossardt BR, Maraganore DM**, The long-term effects of oophorectomy on cognitive and motor aging are age dependent, *Neurodegener Dis* 5:257, 2008.
1209. **Rocca WA, Grossardt BR, Geda YE, Gostout BS, Bower JH, Maraganore DM, de Andrade M, Melton LJ III**, Long-term risk of depressive and anxiety symptoms after early bilateral oophorectomy, *Menopause* 15:1050, 2008.
1210. **Parker WH, Broder MS, Chang E, Feskanich D, Farquhar C, Liu Z, Shoupe D, Berek JS, Hankinson S, Manson JE**, Ovarian conservation at the time of hysterectomy and long-term health outcomes in the Nurses' Health Study, *Obstet Gynecol* 113:1027, 2009.
1211. **Grodstein F, Manson JE, Stampfer MJ**, Hormone therapy and coronary heart disease: the role of time since menopause and age at hormone initiation, *J Womens Health* 15:35, 2006.
1212. **Prentice RL, Langer R, Stefanick ML, Howard BV, Pettinger M, Anderson G, Barad D, Curb JD, Kotchen J, Kuller L, Limacher MC, Wactawski-Wende J; for the Women's Health Initiative Investigators**, Combined postmenopausal hormone therapy and cardiovascular disease: toward resolving the discrepancy between observational studies and the Women's Health Initiative clinical trial, *Am J Epidemiol* 162:404, 2005.
1213. **Harman SM, Black DM, Naftolin F, Brinton EA, Budoff MJ, Cedars MI, Hopkins PN, Lobo RA**,

- Manson JE, Merriam GR, Miller VM, Neal-Perry G, Santoro N, Taylor HS, Vittinghoff E, Yan M, Hodis HN**, Arterial imaging outcomes and cardiovascular risk factors in recently menopausal women: a randomized trial, *Ann Intern Med* 161(4):249, 2014.
1214. **Miller VM, Hodis HN, Lahr BD, Bailey KR, Jayachandran M**, Changes in carotid artery intima-media thickness 3 years after cessation of menopausal hormone therapy: follow-up from the Kronos Early Estrogen Prevention Study, *Menopause* 26(1):24, 2019.
1215. **Hodis HN, Mack WJ, Henderson VW, Shoupe D, Budoff MJ, Hwang-Levine J, Li Y, Feng M, Dustin L, Kono N, Stanczyk FZ, Selzer RH, Azen SP; ELITE Research Group**, Vascular effects of early versus late postmenopausal treatment with estradiol, *N Engl J Med* 374(13):1221, 2016.
1216. **Mikkola TS, Clarkson TB**, Estrogen replacement therapy: atherosclerosis, and vascular function, *Cardiovasc Res* 53:605, 2002.
1217. **Herrington DM, Espeland MA, Crouse JR III, Robertson J, Riley WA, McBurnie MA, Burke GL**, Estrogen replacement and brachial artery flow-mediated vasodilation in older women, *Arterioscler Thromb Vasc Biol* 21:1955, 2001.
1218. **Cushman M, Kuller LH, Prentice R, Rodabough RJ, Psaty BM, Stafford RS, Sidney S, Rosendaal FR; for the Women's Health Initiative Investigators**, Estrogen plus progestin and risk of venous thrombosis, *JAMA* 292:1573, 2004.
1219. **Curb JD, Prentice RL, Bray PF, Langer RD, Van Horn L, Barnabei VM, Bloch MJ, Cyr MG, Gass M, Lepine L, Rodabough RJ, Sidney S, Uwaifo GI, Rosendaal FR**, Venous thrombosis and conjugated equine estrogen in women without a uterus, *Arch Intern Med* 166:772, 2006.
1220. **Cushman M**, Epidemiology and risk factors for venous thrombosis, *Semin Hematol* 44(2):62, 2007.
1221. **Herrington DM, Vittinghoff E, Lin F, Fong J, Harris F, Hunninghake D, Bittner V, Schrott HG, Blumenthal RS, Levy R**, Statin therapy, cardiovascular events, and total mortality in the Heart and Estrogen/Progestin Replacement Study (HERS), *Circulation* 105:2962, 2002.
1222. **Pulmonary Embolism Prevention (PEP) Trial Collaborative Group**, Prevention of pulmonary embolism and deep vein thrombosis with low dose aspirin: pulmonary embolism prevention (PEP) trial, *Lancet* 355:1295, 2000.
1223. **Toorians AWFT, Thomassen MCLGD, Zweegman S, Magdeleyns EJP, Tans G, Gooren LJG, Rosing J**, Venous thrombosis and changes of hemostatic variables during cross-sex hormone treatment in transsexual people, *J Clin Endocrinol Metab* 88:5723, 2003.
1224. **Canonica M, Oger E, Conard J, Meyer G, Lévesque H, Trillot N, Barrellier MT, Wahl D, Emmerich J, Scarabin PY; EStrogen and THromboEmbolism Risk (ESTHER) Study Group**, Obesity and risk of venous thromboembolism among postmenopausal women: differential impact of hormone therapy by route of estrogen administration. The ESTHER Study, *J Thromb Haemost* 4:1259, 2006.
1225. **Canonica M**, Hormone therapy and risk of venous thromboembolism among postmenopausal women, *Maturitas* 82(3):304, 2015.
1226. **Lowe GD, Upton MN, Rumley A, McConnachie A, O'Reilly DS, Watt GC**, Different effects of oral and transdermal hormone replacement therapies on factor IX, APC resistance, t-PA, PAI, and C-reactive protein—a cross-sectional population survey, *Thromb Haemost* 86:550, 2001.
1227. **Hoibraaten E, Qvigstad E, Arnesen H, Larsen S, Wickstrom E, Sandset PM**, Increased risk of recurrent venous thromboembolism during hormone replacement therapy—results of the randomized, double-blind, placebo-controlled estrogen in venous thromboembolism trial (EVTET), *Thromb Haemost* 84:961, 2000.
1228. **Ridker PM, Hennekens CH, Lindpaintner K, Stampfer MJ, Eisenberg PR, Miletich JP**, Mutation in the gene coding for coagulation factor V and the risk of myocardial infarction, stroke, and venous thrombosis in apparently healthy men, *N Engl J Med* 332:912, 1995.
1229. **Cushman M, Rosendall FR, Psaty BM, Cook EF, Valliere J, Kuller LH, Tracy RP**, Factor V Leiden is not a risk factor for arterial vascular disease in the elderly: results from the Cardiovascular Health Study, *Thromb Haemost* 79:912, 1998.
1230. **Glueck CJ, Wang P, Fontaine RN, Sieve-Smith L, Lang JE**, Estrogen replacement therapy, thrombophilia, and atherothrombosis, *Metabolism* 51:724, 2002.

1231. **Irani-Hakime N, Tamim H, Elias G, Choueiry S, Kreidy R, Daccache JL, Almawi WY, Factor V R506Q mutation-Leiden: an independent risk factor for venous thrombosis but not coronary artery disease, J Thromb Thrombolysis 11:111, 2001.**
1232. **American Cancer Society, Cancer Facts & Figures 2008, [http://www.cancer.org/docroot/STT/stt\\_0.asp](http://www.cancer.org/docroot/STT/stt_0.asp), 2009.**
1233. **La Vecchia C, Negri E, Bruzzi P, Dardanoni G, Decarli A, Franceschi S, Palli D, Talamini R, The role of age at menarche and at menopause on breast cancer risk: combined evidence from four case-control studies, Ann Oncol 3:625, 1992.**
1234. **Potischman N, Swanson CA, Siiteri P, Hoover RN, Reversal of relation between body mass and endogenous estrogen concentrations with menopausal status, J Natl Cancer Inst 88:756, 1996.**
1235. **Yong L-C, Brown CC, Schatzkin A, Schairer C, Prospective study of relative weight and risk of breast cancer: the Breast Cancer Detection Demonstration Project follow-up study, 1979 to 1987–1989, Am J Epidemiol 143:985, 1996.**
1236. **Ziegler RG, Hoover RN, Nomura AM, West DW, Wu AH, Pike MC, Lake AJ, Horn-Ross PL, Kolonel LN, Siiteri PK, Fraumeni JF Jr, Relative weight, weight change, height, and breast cancer risk in Asian-American women, J Natl Cancer Inst 88:650, 1996.**
1237. **Sherman B, Wallace R, Beam J, Schlabaugh L, Relationship of body weight to menarcheal and menopausal age: implication for breast cancer risk, J Clin Endocrinol Metab 52:488, 1981.**
1238. **Cauley JA, Lucas FL, Kuller LH, Vogt MT, Browner WS, Cummings SR; for the Study of Osteoporotic Fractures Research Group, Bone mineral density and risk of breast cancer in older women: the Study of Osteoporotic Fractures, JAMA 276:1404, 1996.**
1239. **Zhang Y, Ke DP, Kreger BE, Cupples LA, Ellison RC, Dorgan JE, Schatzkin A, Levy D, Felson DT, Bone mass and the risk of breast cancer among postmenopausal women, N Engl J Med 336:611, 1997.**
1240. **Chen Z, Arendell L, Aickin M, Cauley J, Lewis CE, Chlebowski RT; for the Women's Health Initiative Program, Hip bone density predicts breast cancer risk independently of Gail score: results from the Women's Health Initiative, Cancer 113:907, 2008.**
1241. **Garland CF, Friedlander NJ, Barrett-Connor E, Khaw K-T, Sex hormones and postmenopausal breast cancer: a prospective study in an adult community, Am J Epidemiol 135:1220, 1992.**
1242. **Helzlsouer KJ, Alberg AJ, Bush TL, Longcope C, Gordon GB, Comstock GW, A prospective study of endogenous hormones and breast cancer, Cancer Detect Prev 18:79, 1994.**
1243. **Berrino F, Muti P, Micheli A, Bolelli G, Krogh V, Sciajno R, Pisani P, Panico S, Secreto G, Serum sex hormone levels after menopause and subsequent breast cancer, J Natl Cancer Inst 88:291, 1996.**
1244. **Thomas HV, Key TJ, Allen DS, Moore JW, Dowsett M, Fentiman IS, Wang DY, A prospective study of endogenous serum hormone concentrations and breast cancer risk in post-menopausal women on the island of Guernsey, Br J Cancer 76:401, 1997.**
1245. **Toniolo PG, Levitz M, Zeleniuch-Jacquotte A, Banerjee S, Koenig KL, Shore RE, Strax P, Pasternack BS, A prospective study of endogenous estrogens and breast cancer in postmenopausal women, J Natl Cancer Inst 87:190, 1995.**
1246. **Dorgan JF, Longcope C, Stephenson HE Jr, Falk RT, Miller R, Franz C, Kahle L, Campbell WS, Tangrea JA, Schatzkin A, Relation of prediagnostic serum estrogen and androgen levels to breast cancer risk, Cancer Epidemiol Biomarkers Prev 5:533, 1996.**
1247. **Cuzick J, Wang DY, Bulbrook RD, The prevention of breast cancer, Lancet 1:83, 1986.**
1248. **Hankinson SE, Willett WC, Manson JE, Colditz GA, Hunter DJ, Spiegelman D, Barbieri RL, Speizer FE, Plasma sex steroid hormone levels and risk of breast cancer in postmenopausal women, J Natl Cancer Inst 90:1292, 1998.**
1249. **Colditz GA, Hankinson SE, Hunter DJ, Willett WC, Manson J, Hennekens C, Rosner B, Speizer FE, The use of estrogens and progestins and the risk of breast cancer in postmenopausal women, N Engl J Med 332:1589, 1995.**
1250. **Persson I, Weiderpass E, Bergkvist L, Bergstrom R, Schairer C, Risks of breast and endometrial cancer after estrogen and estrogen-progestin replacement, Cancer Causes Control 10:253, 1999.**

1251. **Magnusson C, Baron JA, Correia N, Bergström R, Adami HO, Persson I**, Breast cancer risk following long-term oestrogen- and oestrogen-progestin-replacement therapy, *Int J Cancer* 81:339, 1999.
1252. **Schairer C, Lubin J, Troisi R, Sturgeon S, Brinton L, Hoover R**, Menopausal estrogen and estrogen-progestin replacement therapy and breast cancer risk, *JAMA* 283:485, 2000.
1253. **Ross RK, Paganini-Hill A, Wan PC, Pike MC**, Effect of hormone replacement therapy on breast cancer risk: estrogen versus estrogen plus progestin, *J Natl Cancer Inst* 92:328, 2000.
1254. **Newcomb PA, Titus-Ernstoff L, Egan KM, Trentham-Dietz A, Baron JA, Storer BE, Willett WC, Stampfer MJ**, Postmenopausal estrogen and progestin use in relation to breast cancer risk, *Cancer Epidemiol Biomarkers Prev* 11:593, 2002.
1255. **Porch JV, Lee IM, Cook NR, Rexrode KM, Buring JE**, Estrogen-progestin replacement therapy and breast cancer risk: the Women's Health Study (United States), *Cancer Causes Control* 13:847, 2002.
1256. **Weiss LK, Burkman RT, Cushing-Haugen KL, Voigt LF, Simon MS, Daling JR, Norman SA, Bernstein L, Ursin G, Marchbanks PA, Strom BL, Berlin JA, Weber AL, Doody DR, Wingo PA, McDonald JA, Malone KE, Folger SG, Spirtas R**, Hormone replacement therapy regimens and breast cancer risk, *Obstet Gynecol* 100:1148, 2002.
1257. **Li CI, Malone KE, Porter PL, Weiss NS, Tang M-T, Cushing-Haugen KL, Daling JR**, Relationship between long durations and different regimens of hormone therapy and risk of breast cancer, *JAMA* 289:3254, 2003.
1258. **Olsson HL, Ingvar C, Bladstrom A**, Hormone replacement therapy containing progestins and given continuously increases breast carcinoma risk in Sweden, *Cancer* 97:1387, 2003.
1259. **Kerlikowske K, Miglioretti DL, Ballard-Barbash R, Weaver DL, Buist DSM, Barlow WE, Cutter G, Geller BM, Yankaskas BC, Taplin SH, Carney PA**, Prognostic characteristics of breast cancer among postmenopausal hormone users in a screened population, *J Clin Oncol* 21:4314, 2003.
1260. **Million Women Study Collaborators**, Breast cancer and hormone-replacement therapy in the Million Women Study, *Lancet* 362:419, 2003.
1261. **Stahlberg C, Pedersen AT, Lyng E, Andersen ZJ, Keiding N, Hundrup YA, Obel EB, Ottesen B**, Increased risk of breast cancer following different regimens of hormone replacement therapy frequently used in Europe, *Int J Cancer* 109:721, 2004.
1262. **Opatrny L, Dell'Aniello S, Assouline S, Suissa S**, Hormone replacement therapy use and variations in the risk of breast cancer, *Br J Obstet Gynaecol* 115:169, 2008.
1263. **Flesch-Janys D, Slinger T, Mutschelknauss E, Kropp S, Obi N, Vettorazzi E, Braendle W, Bastert G, Hentschel S, Berger J, Chang-Claude J**, Risk of different histological types of postmenopausal breast cancer by type and regimen of menopausal hormone therapy, *Int J Cancer* 123:933, 2008.
1264. **Calle EE, Feigelson HS, Hildebrand JS, Teras LR, Thun MJ, Rodriguez C**, Postmenopausal hormone use and breast cancer associations differ by hormone regimen and histologic subtype, *Cancer* 115:936, 2009.
1265. **Jick SS, Hagberg KW, Kaye JA, Jick H**, Postmenopausal estrogen-containing hormone therapy and the risk of breast cancer, *Obstet Gynecol* 113:74, 2009.
1266. **Collaborative Group on Hormonal Factors in Breast Cancer**, Breast cancer and hormone replacement therapy: collaborative reanalysis of data from 51 epidemiological studies of 52,705 women with breast cancer and 108,411 women without breast cancer, *Lancet* 350:1047, 1997.
1267. **Gramling R, Eaton CB, Rothman KJ, Cabral H, Silliman RA, Lash TL**, Hormone replacement therapy, family history, and breast cancer risk among postmenopausal women, *Epidemiology* 20:752, 2009.
1268. **Stahlberg C, Lyng E, Andersen ZJ, Keiding N, Ottesen B, Rank F, Hundrup YA, Obel EB, Pedersen AT**, Breast cancer incidence, case-fatality and breast cancer mortality in Danish women using hormone replacement therapy—a prospective observational study, *Int J Epidemiol* 34:931, 2005.
1269. **Li CI, Malone KE, Porter PL, Lawton TJ, Voigt LF, Cushing-Haugen KL, Lin MG, Yuan X, Daling JR**, Relationship between menopausal hormone therapy and risk of ductal, lobular, and ductal-lobular breast carcinomas, *Cancer Epidemiol Biomarkers Prev* 17:43, 2008.
1270. **Rosenberg LU, Magnusson C, Lindström E, Wedrén S, Hall P, Dickman PW**, Menopausal hormone therapy and other breast cancer risk factors in relation to the risk of different histological subtypes of breast

cancer: a case-control study, *Breast Cancer Res* 8:R11, 2006.

1271. **Chlebowski RT, Hendrix SL, Langer RD, Stefanick ML, Gass M, Lane D, Rodabough RJ, Gilligan MA, Cyr MG, Thomson CA, Khandekar J, Petrovitch H, McTiernan A; for the WHI Investigators**, Influence of estrogen plus progestin on breast cancer and mammography in healthy postmenopausal women. The Women's Health Initiative Randomized Trial, *JAMA* 289:3243, 2003.
1272. **Anderson GL, Chlebowski RT, Rossouw JE, Rodabough RJ, McTiernan A, Margolis KL, Aggerwal A, Curb JD, Hendrix SL, Hubbell FA, Khandekar J, Lane DS, Lasser N, Lopez AM, Potter J, Ritenbaugh C**, Prior hormone therapy and breast cancer risk in the Women's Health Initiative randomized trial of estrogen plus progestin, *Maturitas* 55:103, 2006.
1273. **LaCroix AZ, Chlebowski RT, Manson JE, Aragaki AK, Johnson KC, Martin L, Margolis KL, Stefanick ML, Brzyski R, Curb JD, Howard BV, Lewis CE, Wactawski-Wende J; WHI Investigators**, Health outcomes after stopping conjugated equine estrogens among postmenopausal women with prior hysterectomy: a randomized controlled trial, *JAMA* 305(13):1305, 2011.
1274. **Stefanick ML, Anderson GL, Margolis KL, Hendrix SL, Rodabough RJ, Paskett ED, Lane DS, Hubbell FA, Assaf AR, Sarto GE, Schenken RS, Yasmeen S, Lessin L, Chlebowski RT; for the WHI Investigators**, Effects of conjugated equine estrogens on breast cancer and mammography screening in postmenopausal women with hysterectomy, *JAMA* 295:1647, 2006.
1275. **Anderson GL, Chlebowski RT, Aragaki AK, Kuller LH, Manson JE, Gass M, Bluhm E, Connelly S, Hubbell FA, Lane D, Martin L, Ockene J, Rohan T, Schenken R, Wactawski-Wende J**, Conjugated equine oestrogen and breast cancer incidence and mortality in postmenopausal women with hysterectomy: extended follow-up of the Women's Health Initiative randomised placebo-controlled trial, *Lancet Oncol* 13(5):476, 2012.
1276. **Lyytinen H, Pukkala E, Ylikorkala O**, Breast cancer risk in postmenopausal women using estrogen-only therapy, *Obstet Gynecol* 108:1354, 2006.
1277. **Lyytinen H, Pukkala E, Ylikorkala O**, Breast cancer risk in postmenopausal women using estradiol-progestogen therapy, *Obstet Gynecol* 113:65, 2009.
1278. **Chen WY, Manson JE, Hankinson SE, Rosner B, Holmes MD, Willett WC, Colditz GA**, Unopposed estrogen therapy and the risk of invasive breast cancer, *Arch Intern Med* 166:1027, 2006.
1279. **Topo P, Luoto R, Hemminki E, Uutela A**, Declining socioeconomic differences in the use of menopausal and postmenopausal hormone therapy in Finland, *Maturitas* 32:141, 1999.
1280. **Bergkvist L, Adami H-O, Persson I, Bergstrom R, Krusemo UB**, Prognosis after breast cancer diagnosis in women exposed to estrogen and estrogen-progestogen replacement therapy, *Am J Epidemiol* 130:221, 1989.
1281. **Persson I, Yuen J, Bergkvist L, Schairer C**, Cancer incidence and mortality in women receiving estrogen and estrogen-progestin replacement therapy—long-term follow-up of a Swedish cohort, *Int J Cancer* 67:327, 1996.
1282. **Willis DB, Calle EE, Miracle-McMahill HL, Heath CW Jr**, Estrogen replacement therapy and risk of fatal breast cancer in a prospective cohort of postmenopausal women in the United States, *Cancer Causes Control* 7:449, 1996.
1283. **Sellers TA, Mink PJ, Cerhan JR, Zheng W, Anderson KE, Kushi LH, Folsom AR**, The role of hormone replacement therapy in the risk for breast cancer and total mortality in women with a family history of breast cancer, *Ann Intern Med* 127:973, 1997.
1284. **Schairer C, Gail M, Byrne C, Rosenberg PS, Sturgeon SR, Brinton LA, Hoover RN**, Estrogen replacement therapy and breast cancer survival in a large screening study, *J Natl Cancer Inst* 91:264, 1999.
1285. **Fowble B, Hanlon A, Greedman G, Patchefsky A, Kessler H, Nicolaou N, Hoffman J, Sigurdson E, Boraas M, Goldstein L**, Postmenopausal hormone replacement therapy: effect on diagnosis and outcome in early-stage invasive breast cancer treated with conservative surgery and radiation, *J Clin Oncol* 17:1680, 1999.
1286. **Jernström H, Frenander J, Fernö M, Olsson H**, Hormone replacement therapy before breast cancer diagnosis significantly reduces the overall death rate compared with never-use among 984 breast cancer patients, *Br J Cancer* 80:1453, 1999.

1287. **Nanda K, Bastian LA, Schulz K**, Hormone replacement therapy and the risk of death from breast cancer: a systematic review, *Am J Obstet Gynecol* 186:325, 2002.
1288. **Schuetz F, Diel IJ, Poeschel M, von Holst T, Solomayer EF, Lange S, Sinn P, Bastert G, Sohn C**, Reduced incidence of distant metastases and lower mortality in 1072 patients with breast cancer with a history of hormone replacement therapy, *Am J Obstet Gynecol* 196:342.e1, 2007.
1289. **Christante D, Pommier S, Garreau J, Muller P, LaFleur B, Pommier R**, Improved breast cancer survival among hormone replacement therapy users is durable after 5 years of additional follow-up, *Am J Surg* 196:505, 2008.
1290. **Squitieri R, Tartter P, Ahmed S, Brower ST**, Carcinoma of the breast in postmenopausal hormone user and nonuser control groups, *J Am Coll Surg* 178:167, 1994.
1291. **Bonnier P, Romain S, Giacalone PL, Laffargue F, Martin PM, Piana L**, Clinical and biologic prognostic factors in breast cancer diagnosed during postmenopausal hormone replacement therapy, *Obstet Gynecol* 85:11, 1995.
1292. **Magnusson C, Holmberg L, Norden T, Lindgren A, Persson I**, Prognostic characteristics in breast cancers after hormone replacement therapy, *Breast Cancer Res Treat* 38:325, 1996.
1293. **Harding C, Knox WF, Faragher EB, Baidam A, Bundred NJ**, Hormone replacement therapy and tumour grade in breast cancer: prospective study in screening unit, *Br Med J* 312:1646, 1996.
1294. **Holli K, Isola J, Cuzick J**, Low biologic aggressiveness in breast cancer in women using hormone replacement therapy, *J Clin Oncol* 16:3115, 1998.
1295. **O'Connor IF, Shembekar MV, Shousha S**, Breast carcinoma developing in patients on hormone replacement therapy: a histological and immunohistological study, *J Clin Pathol* 51:935, 1998.
1296. **Salmon RJ, Ansquer Y, Asselain B, Languille O, Lesec G, Remvikos Y**, Clinical and biological characteristics of breast cancers in post-menopausal women receiving hormone replacement therapy for menopause, *Oncol Rep* 6:699, 1999.
1297. **Bilimoria MM, Winchester DJ, Sener SF, Motykie G, Sehgal UL, Winchester DP**, Estrogen replacement therapy and breast cancer: analysis of age of onset and tumor characteristics, *Ann Surg Oncol* 6:200, 1999.
1298. **Stallard S, Litherland JC, Cordiner CM, Dobson HM, George WD, Mallon EA, Hole D**, Effect of hormone replacement therapy on the pathological stage of breast cancer: population based, cross sectional study, *Br Med J* 320:348, 2000.
1299. **Manjer J, Malina J, Berglund G, Bondeson L, Garne JP, Janzon L**, Increased incidence of small and well-differentiated breast tumours in post-menopausal women following hormone-replacement therapy, *Int J Cancer* 92:919, 2001.
1300. **Delgado RC, Lubian Lopez DM**, Prognosis of breast cancers detected in women receiving hormone replacement therapy, *Maturitas* 20:147, 2001.
1301. **Sacchini V, Zurrada S, Andreoni G, Luini A, Galimberti V, Veronesi P, Intra M, Viale G, Veronesi U**, Pathologic and biological prognostic factors of breast cancers in short- and long-term hormone replacement therapy users, *Ann Surg Oncol* 9:266, 2002.
1302. **Cheek J, Lacy J, Toth-Fejel S, Morris K, Calhoun K, Pommier RF**, The impact of hormone replacement therapy on the detection and stage of breast cancer, *Arch Surg* 137:1015, 2002.
1303. **Esteve J, Seradour B, Jacquemier J, Remontet L**, Does a better grade of tumour occurring in women under hormone replacement therapy compensate for their lower probability of detection by screening mammography, *J Med Screen* 9:70, 2002.
1304. **Pappo I, Meirshon I, Karni T, Siegelmann-Danielli N, Stahl-Kent V, Sandbank J, Wasserman I, Halevy A**, The characteristics of malignant breast tumors in hormone replacement therapy users versus nonusers, *Ann Surg Oncol* 11:52, 2004.
1305. **Gertig DM, Erbas B, Fletcher A, Amos A, Kavanagh AM**, Duration of hormone replacement therapy, breast tumour size and grade in a screening programme, *Breast Cancer Res Treat* 80:267, 2003.
1306. **Sener SF, Winchester DJ, Winchester DP, Du H, Barrera E, Bilimoria M, Krantz S, Rabbitt S**, The effects of hormone replacement therapy on postmenopausal breast cancer biology and survival, *Am J Surg*

197:403, 2009.

1307. **Fletcher AS, Erbas B, Kavanagh AM, Hart S, Rodger A, Gertig DM**, Use of hormone replacement therapy (HRT) and survival following breast cancer diagnosis, *Breast* 14:192, 2005.
1308. **Carney PA, Miglioretti DL, Yankaskas BC, Kerlikowske K, Rosenberg R, Rutter CM, Geller BM, Abraham LA, Taplin SH, Dignan M, Cutter G, Ballard-Barbash R**, Individual and combined effects of age, breast density, and hormone replacement therapy use on the accuracy of screening mammography, *Ann Intern Med* 138:168, 2003.
1309. **Carter CL, Allen C, Henson DE**, Relation of tumor size, lymph node status, and survival in 24,740 breast cancer cases, *Cancer* 63:181, 1989.
1310. **Port ER, Tan LK, Borgen PI, Van Zee KJ**, Incidence of axillary lymph node metastases in T1a and T1b breast carcinoma, *Ann Surg Oncol* 5:23, 1998.
1311. **Gajdos C, Tartter PI, Bleiweiss IJ**, Lymphatic invasion, tumor size, and age are independent predictors of axillary lymph node metastases in women with T1 breast cancers, *Ann Surg* 230:692, 1999.
1312. **Heimann R, Munsell M, McBride R**, Mammographically detected breast cancers and the risk of axillary lymph node involvement: is it just the tumor size?, *Cancer J* 8:276, 2002.
1313. **Heiss G, Wallace R, Anderson GL, Aragaki A, Beresford SAA, Brzyski R, Chlebowski RT, Gass M, LaCroix AZ, Manson JE, Prentice RL, Rossouw JE, Stefanick ML; for the WHI Investigators**, Health risks and benefits 3 years after stopping randomized treatment with estrogen and progestin, *JAMA* 299:1036, 2008.
1314. **Crandall CJ, Karlamangla A, Huang MH, Ursin G, Guan M, Greendale GA**, Association of new-onset breast discomfort with an increase in mammographic density during hormone therapy, *Arch Intern Med* 166:1578, 2006.
1315. **Crandall CJ, Aragaki AK, Chlebowski RT, McTiernan A, Anderson G, Hendrix SL, Cochrane BB, Kuller LH, Cauley JA**, New-onset breast tenderness after initiation of estrogen plus progestin therapy and breast cancer risk, *Arch Intern Med* 169:1684, 2009.
1316. **Boyd NF, Martin LJ, Sun L, Chiarelli AM, Hislop G, Yaffe MJ, Minkin S**, Mammographic density as a surrogate marker for the effects of hormone therapy on risk of breast cancer, *Cancer Epidemiol Biomarkers Prev* 15:961, 2006.
1317. **Rockhill B, Spiegelman D, Byrne C, Hunter DJ, Colditz GA**, Validation of the Gail et al. model of breast cancer risk prediction and implications for chemoprevention, *J Natl Cancer Inst* 93:358, 2001.
1318. **Elmore JG, Barton MB, Moceri VM, Polk S, Arena PJ, Fletcher SW**, Ten-year risk of false positive screening mammograms and clinical breast examinations, *N Engl J Med* 338:1089, 1998.
1319. **Freedman M, San Martin J, O’Gorman J, Eckert S, Lippman ME, Lo S-CB, Walls EL, Zeng J**, Digitized mammography: a clinical trial of postmenopausal women randomly assigned to receive raloxifene, estrogen, or placebo, *J Natl Cancer Inst* 93:51, 2001.
1320. **Mandelson MT, Oestreicher N, Porter PL, White D, Finder CA, Taplin SH, White E**, Breast density as a predictor of mammographic detection: comparison of interval- and screen-detected cancers, *J Natl Cancer Inst* 92:1081, 2000.
1321. **Ong G, Austoker J, Brett J**, Breast screening: adverse psychological consequences 1 month after placing women on early recall because of a diagnostic uncertainty. A multicentre study, *J Med Screen* 4:158, 1997.
1322. **El-Bastawissi AY, White E, Mandelson MT, Taplin SH**, Reproductive and hormonal factors associated with mammographic breast density by age (United States), *Cancer Causes Control* 11:955, 2000.
1323. **Boyd NF, Martin LJ, Rommens JM, Paterson AD, Minkin S, Yaffe MJ, Stone J, Hopper JL**, Mammographic density: a heritable risk factor for breast cancer, *Methods Mol Biol* 472:343, 2009.
1324. **Byrne C, Schairer C, Wolfe J, Parekh N, Salane M, Brinton LA, Hoover R, Haile R**, Mammographic features and breast cancer risk: effects with time, age, and menopause status, *J Natl Cancer Inst* 87:1622, 1995.
1325. **Byng JW, Yaffe MJ, Jong RA, Shumak RS, Lockwood GA, Tritchler DL, Boyd NF**, Analysis of mammographic density and breast cancer risk from digitized mammograms, *Radiographics* 18:1587, 1998.
1326. **Ursin G, Ma H, Wu AH, Bernstein L, Salane M, Parisky YR, Astrahan M, Siozon CC, Pike MC**,



- Mammographic density and breast cancer in three ethnic groups, *Cancer Epidemiol Biomarkers Prev* 12:332, 2003.
1327. **Vacek PM, Geller BM**, A prospective study of breast cancer risk using routine mammographic breast density measurements, *Cancer Epidemiol Biomarkers Prev* 13:715, 2004.
1328. **Marugg RC, van der Mooren MJ, Hendriks JHCL, Rolland R, Ruijs SHJ**, Mammographic changes in postmenopausal women on hormonal replacement therapy, *Eur Radiol* 7:749, 1997.
1329. **Persson I, Thurfjell E, Holmberg L**, Effect of estrogen and estrogen-progestin replacement regimens on mammographic parenchymal density, *J Clin Oncol* 15:3201, 1997.
1330. **Sala E, Warren R, McCann J, Duffy S, Luben R, Day N**, High-risk mammographic parenchymal patterns, hormone replacement therapy and other risk factors: a case-control study, *Int J Epidemiol* 29:629, 2000.
1331. **Rutter CM, Mandelson MT, Laya MB, Seger DJ, Taplin S**, Changes in breast density associated with initiation, discontinuation, and continuing use of hormone replacement therapy, *JAMA* 285:171, 2001.
1332. **Greendale GA, Reboussin BA, Sie A, Singh HR, Olson LK, Gatewood O, Bassett LW, Wasilauskas C, Bush T, Barrett-Conner E**, Effects of estrogen and estrogen-progestin on mammographic parenchymal density, *Ann Intern Med* 130:262, 1999.
1333. **McTiernan A, Martin CF, Peck JD, Aragaki A, Chlebowski RT, Pisano ED, Wang CY, Brunner RL, Johnson KC, Manson JE, Lewis CE, Kotchen JM, Hulka BS, Women's Health Initiative Mammogram Density Study Investigators**, Estrogen-plus-progestin use and mammographic density in postmenopausal women: women's health initiative randomized trial, *J Natl Cancer Inst* 97:1366, 2005.
1334. **Lundström E, Wilczek B, von Palffy Z, Söderqvist G, von Schoultz B**, Mammographic breast density during hormone replacement therapy: differences according to treatment, *Am J Obstet Gynecol* 181:348, 1999.
1335. **Lundström E, Wilczek B, von Palffy Z, Söderqvist G, von Schoultz B**, Mammographic breast density during hormone replacement therapy: effects of continuous combination, unopposed transdermal and low-potency estrogen regimens, *Climacteric* 4:42, 2001.
1336. **Erel CT, Esen G, Seyisoglu H, Elter K, Uras C, Ertungealp E, Aksu MF**, Mammographic density increase in women receiving different hormone replacement regimens, *Maturitas* 40:151, 2001.
1337. **Ziv E, Tice J, Smith-Bindman R, Shepherd J, Cummings S, Kerlikowske K**, Mammographic density and estrogen receptor status of breast cancer, *Cancer Epidemiol Biomarkers Prev* 13:2090, 2004.
1338. **Roubidoux MA, Bailey JE, Wray LA, Helvie MA**, Invasive cancers detected after breast cancer screening yielded a negative result: relationship of mammographic density to tumor prognostic factors, *Radiology* 230:42, 2004.
1339. **Ziv E, Shepherd J, Smith-Bindman R, Kerlikowske K**, Mammographic breast density and family history of breast cancer, *J Natl Cancer Inst* 95:556, 2003.
1340. **Vachon CM, Sellers TA, Vierkant RA, Wu FF, Brandt KR**, Case-control study of increased mammographic breast density response to hormone replacement therapy, *Cancer Epidemiol Biomarkers Prev* 11:1382, 2002.
1341. **Harvey JA, Santen RJ, Petroni GR, Bovbjerg VE, Smolkin ME, Sheriff FS, Russo J**, Histologic changes in the breast with menopausal hormone therapy use: correlation with breast density, estrogen receptor, progesterone receptor, and proliferation indices, *Menopause* 15:67, 2008.
1342. **Cigler T, Tu D, Yaffe MJ, Findlay B, Verma S, Johnston D, Richardson H, Hu H, Qi S, Goss PE**, A randomized, placebo-controlled trial (NCIC CTG MAP1) examining the effects of letrozole on mammographic breast density and other end organs in postmenopausal women, *Breast Cancer Res Treat* 120(2):427, 2010.
1343. **Berkowitz JE, Gatewood OMB, Goldblum LE, Gayler BW**, Hormonal replacement therapy: mammographic manifestations, *Radiology* 174:199, 1990.
1344. **Harvey JA, Pinkerton JV, Herman CR**, Short-term cessation of hormone replacement therapy and improvement of mammographic specificity, *J Natl Cancer Inst* 89:1623, 1997.
1345. **Colacurci N, Fornaro F, De Franciscis P, Mele D, Palermo M, del Vecchio W**, Effects of a short-term suspension of hormone replacement therapy on mammographic density, *Fertil Steril* 76:451, 2001.
1346. **Buist DS, Anderson ML, Reed SD, Aiello Bowles EJ, Fitzgibbons ED, Gandara JC, Seger D, Newton KM**, Short-term hormone therapy suspension and mammography recall: a randomized trial, *Ann Intern Med*

150:752, 2009.

1347. **Weaver K, Kataoka M, Murray J, Muir B, Anderson E, Warren R, Warsi I, Highnam R, Glasier A**, Does a short cessation of HRT decrease mammographic density?, *Maturitas* 59:315, 2008.
1348. **Lundström E, Bygdesson M, Svane G, Azavedo E, Von Schoultz B**, Neutral effect of ultra-low-dose continuous combined estradiol and norethisterone acetate on mammographic breast density, *Climacteric* 10:249, 2007.
1349. **Lundström E, Söderqvist G, Svane G, Azavedo E, Olovsson M, Skoog L, von Schoultz E, Von Schoultz B**, Digitized assessment of mammographic breast density in patients who received low-dose intrauterine levonorgestrel in continuous combination with oral estradiol valerate: a pilot study, *Fertil Steril* 85:989, 2006.
1350. **Dinger J, Bardenheuer K, Minh TD**, Levonorgestrel-releasing and copper intrauterine devices and the risk of breast cancer, *Contraception* 83(3):211, 2011.
1351. **Bleyer A, Welch HG**, Effect of three decades of screening mammography on breast-cancer incidence, *N Engl J Med* 367(21):1998, 2012.
1352. **Banks E**, Hormone replacement therapy and the sensitivity and specificity of breast cancer screening: a review, *J Med Screen* 8:29, 2001.
1353. **Laya MB, Larson EB, Taplin SH, White E**, Effect of estrogen replacement therapy on the specificity and sensitivity of screening mammography, *J Natl Cancer Inst* 88:643, 1996.
1354. **Rosenberg RD, Hunt WC, Williamson MR, Gilliland FD, Wiest PW, Kelsey CA, Key CR, Linver MN**, Effects of age, breast density, ethnicity, and estrogen replacement therapy on screening mammographic sensitivity and cancer stage at diagnosis: review of 183,134 screening mammograms in Albuquerque, New Mexico, *Radiology* 209:511, 1998.
1355. **Litherland JC, Stallard S, Hole D, Cordiner C**, The effect of hormone replacement therapy on the sensitivity of screening mammograms, *Clin Radiol* 54:285, 1999.
1356. **Kavanagh AM, Mitchell H, Giles GG**, Hormone replacement therapy and accuracy of mammographic screening, *Lancet* 355:270, 2000.
1357. **Salminen TM, Saarenmaa IE, Heikkilä MM, Hakama M**, Is a dense mammographic parenchymal pattern a contraindication to hormonal replacement therapy?, *Acta Oncol* 39:969, 2000.
1358. **Séradour B, Estève J, Heid P, Jacquemier J**, Hormone replacement therapy and screening mammography: analysis of the results in the Bouches du Rhône programme, *J Med Screen* 6:99, 1999.
1359. **Moy L, Slanetz PJ, Yeh ED, Moore RH, Rafferty EA, Kopans DB**, Hormone replacement therapy rarely complicates or alters interpretation on screening mammography: a prospective analysis (abstract), *Radiology* 217:446, 2000.
1360. **Carney PA, Kasales CJ, Tosteson AN, Weiss JE, Goodrich ME, Poplack SP, Wells WS, Titus-Ernstoff L**, Likelihood of additional work-up among women undergoing routine screening mammography: the impact of age, breast density, and hormone therapy use, *Prev Med* 39:48, 2004.
1361. **Chlebowski RT, Anderson G, Pettinger M, Lane D, Langer RD, Gilligan MA, Walsh BW, Chen C, McTiernan A; Women's Health Initiative Investigators**, Estrogen and progestin and breast cancer detection by means of mammography and breast biopsy, *Arch Intern Med* 168:370, 2008.
1362. **Berg WA, Blume JD, Cormack JB, Mendelson EB, Lehrer D, Böhm-Vélez M, Pisano ED, Jong RA, Evans WP, Morton MJ, Mahoney MC, Larsen LH, Barr RG, Farria DM, Marques HS, Boparai K; for the ACRIN 6666 Investigators**, Combined screening with ultrasound and mammography vs mammography alone in women at elevated risk of breast cancer, *JAMA* 299:2151, 2008.
1363. **Corsetti V, Ferrari A, Ghirardi M, Bergonzini R, Bellarosa S, Angelina O, Bani C, Ciotto S**, Role of ultrasonography in detecting mammographically occult breast carcinoma in women with dense breasts, *Radiol Med* 111:440, 2006.
1364. **Melnikow J, Fenton JJ, Whitlock EP, Miglioretti DL, Weyrich MS, Thompson JH, Shah K; U.S. Preventive Services Task Force Evidence Syntheses, formerly Systematic Evidence Reviews**, Supplemental Screening for Breast Cancer in Women With Dense Breasts: A Systematic Review for the US Preventive Service Task Force, Agency for Healthcare Research and Quality (US), Rockville, 2016.

1365. **Pisano ED, Hendrick RE, Yaffe MJ, Baum JK, Acharyya S, Cormack JB, Hanna LA, Conant EF, Fajardo LL, Bassett LW, D'Orsi CJ, Jong RA, Rebner M, Tosteson AN, Gatsonis CA, Group DI**, Diagnostic accuracy of digital versus film mammography: exploratory analysis of selected population subgroups in DMIST, *Radiology* 246:376, 2008.
1366. **Wertheimer MD, Costanza ME, Dodson TF, D'Orsi C, Pastides H, Zapka JG**, Increasing the effort toward breast cancer detection, *JAMA* 255:1311, 1986.
1367. **Chen WY, Hankinson SE, Schnitt SJ, Rosner BA, Holmes MD, Colditz GA**, Association of hormone replacement therapy to estrogen and progesterone receptor status in invasive breast carcinoma, *Cancer* 101:1490, 2004.
1368. **Henderson BE, Ross RK, Judd HL, Krailo MD, Pike MC**, Do regular ovulatory cycles increase breast cancer risk?, *Cancer* 56:1206, 1985.
1369. **Tjønneland A, Christensen J, Thomsen BL, Olsen A, Overvad K, Ewertz M, Møller S, Møller S, Rank F**, Hormone replacement therapy in relation to breast carcinoma incidence rate ratios. A prospective Danish cohort study, *Cancer* 100:2328, 2004.
1370. **Stahlberg C, Pedersen AT, Andersen ZJ, Keiding N, Hundrup YA, Obel EB, Møller S, Rank F, Ottesen B, Lynge E**, Breast cancer with different prognostic characteristics developing in Danish women using hormone replacement therapy, *Br J Cancer* 91:644, 2004.
1371. **Hwang ES, Chew T, Shiboski S, Farren G, Benz CC, Wrensch M**, Risk factors for estrogen receptor-positive disease, *Arch Surg* 140:58, 2005.
1372. **Kumar AS, Cureton E, Shim V, Sakata T, Moore DH, Benz CC, Esserman LJ, Hwang ES**, Type and duration of exogenous hormone use affects breast cancer histology, *Ann Surg Oncol* 14:695, 2007.
1373. **Fournier A, Berrino F, Riboli E, Clavel-Chapelon F**, Breast cancer risk in relation to different types of hormone replacement therapy in the E3N-EPIC cohort, *Int J Cancer* 114:448, 2005.
1374. **Fournier A, Berrino F, Clavel-Chapelon F**, Unequal risks for breast cancer associated with different hormone replacement therapies: results from E3N cohort study, *Breast Cancer Res Treat* 107:103, 2008.
1375. **Fournier A, Mesrine S, Boutron-Ruault MC, Clavel-Chapelon F**, Estrogen-progestagen menopausal hormone therapy and breast cancer: does delay from menopause onset to treatment initiation influence risks?, *J Clin Oncol* 27:5138, 2009.
1376. **Frasor J, Danes JM, Komm B, Chang KC, Lyttle CR, Katzenellenbogen BS**, Profiling of estrogen up- and down-regulated gene expression in human breast cancer cells: insights into gene networks and pathways underlying estrogenic control of proliferation and cell phenotype, *Endocrinology* 144:4562, 2003.
1377. **Hall P, Ploner A, Bjöhle J, Huang F, Lin C-Y, Liu ET, Miller LD, Nordgren H, Pawitan Y, Shaw P, Skoog L, Smeds J, Wedrén S, Öhd J, Bergh J**, Hormone-replacement therapy influences gene expression profiles and is associated with breast-cancer prognosis: a cohort study, *BMC Med* 4:16, 2006.
1378. **Wang X, Mori I, Tang W, Nakamura M, Nakamura Y, Sato M, Sakurai T, Kakudo K**, p63 expression in normal, hyperplastic and malignant breast tissues, *Breast Cancer* 9:216, 2002.
1379. **Conneely OM, Jericevic BM, Lydon JP**, Progesterone receptors in mammary gland development and tumorigenesis, *J Mammary Gland Biol Neoplasia* 8:205, 2003.
1380. **Horwitz KB, Tung L, Takimoto GS**, Novel mechanisms of antiprogestin action, *J Steroid Biochem Mol Biol* 53:9, 1995.
1381. **Read LD, Katzenellenbogen BS**, Characterization and regulation of estrogen and progesterone receptors in breast cancer, *Cancer Treat Res* 61:277, 1992.
1382. **Kastner P, Krust A, Turcotte B, Stropp U, Tora L, Gronemeyer H, Chambon P**, Two distinct estrogen-regulated promoters generate transcripts encoding the two functionally different human progesterone receptor forms A and B, *EMBO J* 9:1603, 1990.
1383. **Feil PD, Clarke CL, Satyaswaroop PG**, Progesterone-mediated changes in progesterone receptor forms in the normal human endometrium, *Endocrinology* 123:2506, 1988.
1384. **McDonnell DP, Goldman ME**, RU486 exerts antiestrogenic activities through a novel progesterone receptor A form-mediated mechanism, *J Biol Chem* 269:11945, 1994.
1385. **McDonnell DP, Shahbaz MM, Vegeto E, O'Malley BW**, The human progesterone receptor A-form

functions as a transcriptional modulator of mineralocorticoid receptor transcriptional activity, *J Steroid Biochem Mol Biol* 48:425, 1994.

1386. **Richer JK, Jacobsen BM, Manning NG, Abel MG, Wolf DM, Horwitz KB**, Differential gene regulation by the two progesterone receptor isoforms in human breast cancer cells, *J Biol Chem* 277:5209, 2002.
1387. **Giangrande PH, Kimbrel EA, Edwards DP, McDonnell DP**, The opposing transcriptional activities of the two isoforms of the human progesterone receptor are due to differential cofactor binding, *Mol Cell Biol* 20:3102, 2000.
1388. **Jacobsen BM, Schittone SA, Richer JK, Horwitz KB**, Progesterone-independent effects of human progesterone-receptors (PRs) in estrogen receptor-positive breast cancer: PR isoform-specific gene regulation and tumor biology, *Mol Endocrinol* 19:574, 2005.
1389. **Hopp TA, Weiss HL, Hilsenbeck SG, Cui Y, Allred DC, Horwitz KB, Fuqua SA**, Breast cancer patients with progesterone receptor rich PR-A-rich tumors have poorer disease-free survival rates, *Clin Cancer Res* 10:2751, 2004.
1390. **Mote PA, Leary JA, Avery KA, Sandelin K, Chenevix-Trench G, Kirk JA, Clarke CL**, Germ-line mutations in BRCA1 or BRCA2 in the normal breast are associated with altered expression of estrogen-responsive proteins and the predominance of progesterone receptor A, *Genes Chromosomes Cancer* 39:236, 2004.
1391. **Isaksson E, Wang H, Sahlin L, von Schoultz B, Cline JM, von Schoultz E**, Effects of long-term HRT and tamoxifen on the expression of progesterone receptors A and B in breast tissue from surgically postmenopausal cynomolgus macaques, *Breast Cancer Res Treat* 79:233, 2003.
1392. **Toth-Fejel S, Cheek J, Calhoun K, Muller P, Pommier RF**, Estrogen and androgen receptors as comediators of breast cancer cell proliferation: providing a new therapeutic tool, *Arch Surg* 139:50, 2004.
1393. **Garreau JR, Muller P, Pommier R, Pommier S**, Transgenic introduction of androgen receptor into estrogen-receptor-, progesterone-receptor-, and androgen-receptor-negative breast cancer cells renders them responsive to hormonal manipulation, *Am J Surg* 191:576, 2006.
1394. **Russo J, Russo IH**, The role of estrogen in the initiation of breast cancer, *J Steroid Biochem Mol Biol* 102:89, 2006.
1395. **The Endogenous Hormones and Breast Cancer Collaborative Group**, Endogenous sex hormones and breast cancer in postmenopausal women: reanalysis of nine prospective studies, *J Natl Cancer Inst* 94:606, 2002.
1396. **Key TJ, Appleby PN, Reeves GK, Roddam A, Dorgan JF, Longcope C, Stanczyk FZ, Stephenson HE Jr, Falk RT, Miller R, Schatzkin A, Allen DS, Fentiman IS, Key TJ, Wang DY, Dowsett M, Thomas HV, Hankinson SE, Toniolo P, Akhmedkhanov A, Koenig K, Shore RE, Zeleniuch-Jacquotte A, Berrino F, Muti P, Micheli A, Krogh V, Sieri S, Pala V, Venturelli E, Secreto G, Barrett-Connor E, Laughlin GA, Kabuto M, Akiba S, Stevens RG, Neriishi K, Land CE, Cauley JA, Kuller LH, Cummings SR, Helzlsouer KJ, Alberg AJ, Bush TL, Comstock GW, Gordon GB, Miller SR, Longcope C; Endogenous Hormones Breast Cancer Collaborative Group**, Body mass index, serum sex hormones, and breast cancer risk in postmenopausal women, *J Natl Cancer Inst* 95:1218, 2003.
1397. **Key TJA, Pike MC**, The role of oestrogens and progestogens in the epidemiology and prevention of breast cancer, *Eur J Cancer Clin Oncol* 24:29, 1988.
1398. **Anderson TJ, Ferguson DJP, Raab GM**, Cell turnover in the "resting" human breast: influence of parity, contraceptive pill, age and laterality, *Br J Cancer* 46:376, 1982.
1399. **Ménard S, Casalini P, Agresti R, Pilotti S, Balsari A**, Proliferation of breast carcinoma during menstrual phases, *Lancet* 352:148, 1998.
1400. **Chang K-J, Lee TTY, Linarez-Cruz G, Fournier S, de Lignières B**, Influences of percutaneous administration of estradiol and progesterone on human breast epithelial cell cycle in vivo, *Fertil Steril* 63:785, 1995.
1401. **Laidlaw IJ, Clarke RB, Howell A, Owen AW, Potten CS, Anderson E**, The proliferation of normal human breast tissue implanted into athymic nude mice is stimulated by estrogen but not progesterone, *Endocrinology* 136:164, 1996.

1402. **Foidart J-M, Colin C, Denoo X, Desreux J, Béliard A, Fournier S, de Lignières B**, Estradiol and progesterone regulate the proliferation of human breast epithelial cells, *Fertil Steril* 69:963, 1998.
1403. **Gompel A, Malet C, Spritzer P, Lalardrie J-P, Kuttenn F, Mauvais-Jarvis P**, Progestin effect on cell proliferation and 17-hydroxysteroid dehydrogenase activity in normal human breast cells in culture, *J Clin Endocrinol Metab* 63:1174, 1986.
1404. **Conner P, Christow A, Kersemaekers W, Söderqvist G, Skoog L, Carlström K, Tani E, Mol-Arts M, von Schoultz B**, A comparative study of breast cell proliferation during hormone replacement therapy: effects of tibolone and continuous combined estrogen-progestogen treatment, *Climacteric* 7:50, 2004.
1405. **Hofseth LJ, Raafat AM, Oscuch JR, Pathak DR, Slomski CA, Haslam SZ**, Hormone replacement therapy with estrogen or estrogen plus medroxyprogesterone acetate is associated with increased epithelial proliferation in the normal postmenopausal breast, *J Clin Endocrinol Metab* 84:4559, 1999.
1406. **Gompel A, Somai S, Chaouat M, Kazem A, Kloosterboer HJ, Beusman I, Forgez P, Mimoun M, Rostene W**, Hormonal regulation of apoptosis in breast cells and tissues, *Steroids* 65:593, 2000.
1407. **Stute P, Wood CE, Kapaln JR, Cline JM**, Cyclic changes in the mammary gland of cynomolgus macaques, *Fertil Steril* 82(Suppl 3):1160, 2004.
1408. **Stanczyk FZ, Hapgood JP, Winer S, Mishell DR Jr**, Progestogens used in postmenopausal hormone therapy: differences in their pharmacological properties, intracellular actions, and clinical effects, *Endocr Rev* 34(2):171, 2013.
1409. **Courtin A, Communal L, Vilasco M, Cimino D, Mourra N, de Bortoli M, Taverna D, Faussat AM, Chaouat M, Forgez P, Gompel A**, Glucocorticoid receptor activity discriminates between progesterone and medroxyprogesterone acetate effects in breast cells, *Breast Cancer Res Treat* 131(1):49, 2012.
1410. **Sweeney EE, Fan P, Jordan VC**, Molecular modulation of estrogen-induced apoptosis by synthetic progestins in hormone replacement therapy: an insight into the women's health initiative study, *Cancer Res* 74(23):7060, 2014.
1411. **Xu B, Kitawaki J, Koshiba H, Ishihara H, Kiyomizu M, Teramoto M, Kitaoka Y, Honjo H**, Differential effects of progestogens, by type and regimen, on estrogen-metabolizing enzymes in human breast cancer cells, *Maturitas* 56(2):142, 2007.
1412. **Cline JM, Soderqvist G, von Schoultz E, Skoog L, von Schoultz B**, Effects of hormone replacement therapy on the mammary gland of surgically postmenopausal cynomolgus macaques, *Am J Obstet Gynecol* 174:93, 1996.
1413. **Wood CE, Sitruk-Ware RL, Tsong Y-Y, Register TC, Lees CJ, Cline JM**, Effects of estradiol with oral or intravaginal progesterone on risk markers for breast cancer in a postmenopausal monkey model, *Menopause* 14:1, 2007.
1414. **Wood CE, Sitruk-Ware RL, Tsong Y-Y, Register TC, Lees CJ, Cline JM**, Effects of estradiol with micronized progesterone or medroxyprogesterone acetate on risk markers for breast cancer in postmenopausal monkeys, *Breast Cancer Res Treat* 101:125, 2007.
1415. **Conner P, Register TC, Skoog L, Tani E, von Schoultz B, Cline JM**, Expression of p53 and markers for apoptosis in breast tissue during long-term hormone therapy in cynomolgus monkeys, *Am J Obstet Gynecol* 193:58, 2005.
1416. **Micheli A, Muti P, Secreto G, Krogh V, Meneghini E, Venturelli E, Sieri S, Pala V, Berrino F**, Endogenous sex hormones and subsequent breast cancer in premenopausal women, *Int J Cancer* 112:312, 2004.
1417. **Eliassen AH, Missmer SA, Tworoger SS, Spiegelman D, Barbieri RL, Dowsett M, Hankinson SE**, Endogenous steroid hormone concentrations and risk of breast cancer among premenopausal women, *J Natl Cancer Inst* 98:1406, 2006.
1418. **Chen W, Petitti DB, Geiger AM**, Mortality following development of breast cancer while using oestrogen or oestrogen plus progestin: a computer record-linkage study, *Br J Cancer* 93:392, 2005.
1419. **Newcomb PA, Egan KM, Trentham-Dietz A, Titus-Ernstoff L, Baron JA, Hampton JM, Stampfer MJ, Willett WC**, Prediagnostic use of hormone therapy and mortality after breast cancer, *Cancer Epidemiol Biomarkers Prev* 17:864, 2008.

1420. **Ravdin PM, Cronin KA, Howlander N, Berg CD, Chlebowski RT, Feuer EJ, Edwards BK, Berry DA**, The decrease in breast-cancer incidence in 2003 in the United States, *N Engl J Med* 356:1670, 2007.
1421. **Glass AG, Lacey JV, Carreon JD, Hoover RN**, Breast cancer incidence, 1980–2006: combined roles of menopausal hormone therapy, screening mammography, and estrogen receptor status, *J Natl Cancer Inst* 99:1152, 2007.
1422. **Clarke CA, Glaser SL, Uratsu CS, Selby JV, Kushi LH, Herrinton LJ**, Recent declines in hormone therapy utilization and breast cancer incidence: clinical and population-based evidence, *J Clin Oncol* 24:e49, 2006.
1423. **Kerlikowske K, Miglioretti DL, Buist DS, Walker R, Carney PA; National Cancer Institute-Sponsored Breast Cancer Surveillance Consortium**, Declines in invasive breast cancer and use of postmenopausal hormone therapy in a screening mammography population, *J Natl Cancer Inst* 99:1335, 2007.
1424. **Fournier A, Boutron-Ruault M-C, Françoise C-C**, Breast cancer and hormonal therapy in postmenopausal women (Letter to the Editor), *N Engl J Med* 360:22, 2009.
1425. **Sharpe KH, McClements P, Clark DI, Collins J, Springbett A, Brewster DH**, Reduced risk of oestrogen receptor positive breast cancer among peri- and post-menopausal women in Scotland following a striking decrease in use of hormone replacement therapy, *Eur J Cancer* 46(5):937, 2010.
1426. **Bouchardy C, Usel M, Verkooijen HM, Fioretta G, Benhamou S, Neyroud-Caspar I, Schaffar R, Vlastos G, Wespik Y, Schäfer P, Rapiti E**, Changing pattern of age-specific breast cancer incidence in the Swiss canton of Geneva, *Breast Cancer Res Treat* 120(2):519, 2009.
1427. **Canfell K, Banks E, Moa AM, Beral V**, Decrease in breast cancer incidence following a rapid fall in use of hormone replacement therapy in Australia, *Med J Aust* 188:641, 2008.
1428. **Chlebowski RT, Kuller LH, Prentice RL, Stefanick ML, Manson JE, Gass M, Aragaki A, Ockene JK, Lane DS, Sarto GE, Rajkovic A, Schenken RS, Hendrix SL, Ravdin PM, Rohan TE, Yasmeen S, Anderson G; for the WHI Investigators**, Breast cancer after use of estrogen plus progestin in postmenopausal women, *N Engl J Med* 360:573, 2009.
1429. **Bouchardy C, Morabia A, Verkooijen HM, Fioretta G, Wespi Y, Schäfer P**, Remarkable change in age-specific breast cancer incidence in the Swiss canton of Geneva and its possible relation with the use of hormone replacement therapy, *BMC Cancer* 6:78, 2006.
1430. **Manson JE, Chlebowski RT, Stefanick ML, Aragaki AK, Rossouw JE, Prentice RL, Anderson G, Howard BV, Thomson CA, LaCroix AZ, Wactawski-Wende J, Jackson RD, Limacher M, Margolis KL, Wassertheil-Smoller S, Beresford SA, Cauley JA, Eaton CB, Gass M, Hsia J, Johnson KC, Kooperberg C, Kuller LH, Lewis CE, Liu S, Martin LW, Ockene JK, O'Sullivan MJ, Powell LH, Simon MS, Van Horn L, Vitolins MZ, Wallace RB**, Menopausal hormone therapy and health outcomes during the intervention and extended poststopping phases of the Women's Health Initiative randomized trials, *JAMA* 310(13):1353, 2013.
1431. **Hsieh RW, Rajan SS, Sharma SK, Greene GL**, Molecular characterization of a B-ring unsaturated estrogen: implications for conjugated equine estrogen components of premarin, *Steroids* 73(1):59, 2008.
1432. **Heldring N, Pike A, Andersson S, Matthews J, Cheng G, Hartman J, Tujague M, Ström A, Treuter E, Warner M, Gustafsson JA**, Estrogen receptors: how do they signal and what are their targets, *Physiol Rev* 87(3):905, 2000.
1433. **Bhavnani BR, Tam SP, Lu X**, Structure activity relationships and differential interactions and functional activity of various equine estrogens mediated via estrogen receptors (ERs) ERalpha and ERbeta, *Endocrinology* 149(10):4857, 2008.
1434. **Lazennec G, Bresson D, Lucas A, Chauveau C, Vignon F**, ER beta inhibits proliferation and invasion of breast cancer cells, *Endocrinology* 142(9):4120, 2001.
1435. **Strom A, Hartman J, Foster JS, Kietz S, Wimalasena J, Gustafsson JA**, Estrogen receptor beta inhibits 17beta-estradiol-stimulated proliferation of the breast cancer cell line T47D, *Proc Natl Acad Sci U S A* 101(6):1566, 2004.
1436. **Song Y, Santen RJ, Wang JP, Yue W**, Inhibitory effects of a bazedoxifene/conjugated equine estrogen combination on human breast cancer cells in vitro, *Endocrinology* 154(2):656, 2013.

1437. **Berrodin TJ, Chang KC, Komm BS, Freedman LP, Nagpal S**, Differential biochemical and cellular actions of Premarin estrogens: distinct pharmacology of bazedoxifene-conjugated estrogens combination, *Mol Endocrinol* 23(1):74, 2009.
1438. **Flores VA, Taylor HS**, The effect of menopausal hormone therapies on breast cancer: avoiding the risk, *Endocrinol Metab Clin North Am* 44(3): 587, 2015.
1439. **Rebbeck TR, Levin AM, Eisen A, Snyder C, Watson P, Cannon-Albright L, Isaacs C, Olopade OI, Garber JE, Godwin AK, Daly MB, Narod SA, Neuhausen SL, Lynch HT, Weber BL**, Breast cancer risk after bilateral prophylactic oophorectomy in BRCA1 mutation carriers, *J Natl Cancer Inst* 91:1475, 1999.
1440. **Rebbeck TR, Friebel T, Wagner T, Lynch HT, Garber JE, Daly MB, Isaacs C, Olopade OI, Neuhausen SL, van't Veer L, Eeles R, Evans DG, Tomlinson G, Matloff E, Narod SA, Eisen A, Domchek S, Armstrong K, Weber BL**, Effect of short-term hormone replacement therapy on breast cancer risk reduction after bilateral prophylactic oophorectomy in BRCA1 and BRCA2 mutation carriers: the PROSE study, *J Clin Oncol* 23:7804, 2005.
1441. **Eisen A, Lubinski J, Gronwald J, Moller P, Lynch HT, Kim-Sing C, Neuhausen SL, Gilbert L, Ghadirian P, Manoukian S, Rennert G, Friedman E, Isaacs C, Rosen E, Rosen B, Daly M, Sun P, Narod SA; Hereditary Breast Cancer Clinical Study Group**, Hormone therapy and the risk of breast cancer in BRCA1 mutation carriers, *J Natl Cancer Inst* 100:1361, 2008.
1442. **Kurman RJ, Kaminski PF, Norris HJ**, The behavior of endometrial hyperplasia. A long-term study of "untreated" hyperplasia in 170 patients, *Cancer* 56:403, 1985.
1443. **Grady D, Gebretsadik T, Kerlikowske K, Ernster V, Petitti D**, Hormone replacement therapy and endometrial cancer risk: a meta-analysis, *Obstet Gynecol* 85:304, 1995.
1444. **Weiss NS, Hill DA**, Postmenopausal estrogen and the incidence of gynecologic cancer, *Maturitas* 23:235, 1996.
1445. **Shapiro S, Kelly JP, Rosenberg L, Kaufman DW, Helmrich SP, Rosenshein NB, Lewis JL Jr, Knapp RC, Stolley PD, Schottenfeld D**, Risk of localized and widespread endometrial cancer in relation to recent and discontinued use of conjugated estrogens, *N Engl J Med* 313:969, 1985.
1446. **Buring JE, Bain CJ, Ehrmann RL**, Conjugated estrogen use and risk of endometrial cancer, *Am J Epidemiol* 124:434, 1986.
1447. **Lacey JV Jr, Brinton LA, Lubin JH, Sherman ME, Schatzkin A, Schairer C**, Endometrial carcinoma risks among menopausal estrogen plus progestin and unopposed estrogen users in a cohort of postmenopausal women, *Cancer Epidemiol Biomarkers Prev* 14:1724, 2005.
1448. **Paganini-Hill A, Ross RK, Henderson BE**, Endometrial cancer and patterns of use of oestrogen replacement therapy: a cohort study, *Br J Cancer* 59:445, 1989.
1449. **Schiff I, Sela HK, Cramer D, Tulchinsky D, Ryan KJ**, Endometrial hyperplasia in women on cyclic or continuous estrogen regimens, *Fertil Steril* 37:79, 1982.
1450. **Notelovitz M, Varner RE, Rebar RW, Fleischmann R, McIlwain HH, Schwartz SL, Sperling M, Wilborn W, Yang H-M, Silfen SL**, Minimal endometrial proliferation over a two-year period in postmenopausal women taking 0.3 mg of unopposed esterified estrogens, *Menopause* 4:80, 1997.
1451. **Johnson SR, Ettinger B, Macer JL, Ensrud KE, Quan J, Grady D**, Uterine and vaginal effects of unopposed ultralow-dose transdermal estradiol, *Obstet Gynecol* 105:779, 2005.
1452. **Cushing KL, Weiss NL, Voigt LF, McKnight B, Beresford SAA**, Risk of endometrial cancer in relation to use of low-dose, unopposed estrogens, *Obstet Gynecol* 91:35, 1998.
1453. **Thom MH, White PJ, Williams RM, Sturdee PW, Paterson MEL, Wade-Evans T, Studd JWW**, Prevention and treatment of endometrial disease in climacteric women receiving estrogen, *Lancet* 2:455, 1979.
1454. **Whitehead MI, Townsend PT, Pryse-Davies J, Ryder TA, King RJB**, Effects of estrogen and progestins on the biochemistry and morphology of the postmenopausal endometrium, *N Engl J Med* 305:1599, 1981.
1455. **Gambrell RD Jr, Babgnell CA, Greenblatt RB**, Role of estrogens and progesterone in the etiology and prevention of endometrial cancer: a review, *Am J Obstet Gynecol* 146:696, 1983.
1456. **Persson I, Adami H-O, Bergkvist L, Lindgren A, Pettersson B, Hoover R, Schairer C**, Risk of endometrial cancer after treatment with oestrogens alone or in conjunction with progestogens: results of a

prospective study, *Br Med J* 298:147, 1989.

1457. **Voigt LF, Weiss NS, Chu JR, Daling J, McKnight B, van Belle G**, Progestagen supplementation of exogenous oestrogens and risk of endometrial cancer, *Lancet* 338:274, 1991.
1458. **Strom BL, Schinnar R, Weber AL, Bunin G, Berlin JA, Baumgarten M, DeMichele A, Rubin SC, Berlin M, Troxel AB, Rebbeck TR**, Case-control study of postmenopausal hormone replacement therapy and endometrial cancer, *Am J Epidemiol* 164:775, 2006.
1459. **Varma TR**, Effect of long-term therapy with estrogen and progesterone on the endometrium of postmenopausal women, *Acta Obstet Gynecol Scand* 64:41, 1985.
1460. **Pike MC, Peters RK, Cozen W, Probst-Hensch NM, Felix JC, Wan PC, Mack TM**, Estrogen-progestin replacement therapy and endometrial cancer, *J Natl Cancer Inst* 89:1110, 1997.
1461. **Beresford SA, Weiss NS, Voigt LF, McKnight B**, Risk of endometrial cancer in relation to use of oestrogen combined with cyclic progestagen therapy in postmenopausal women, *Lancet* 349:458, 1997.
1462. **Weiderpass E, Adami HO, Baron JA, Magnusson C, Bergstrom R, Lindgren A, Correia N, Persson I**, Risk of endometrial cancer following estrogen replacement with and without progestins, *J Natl Cancer Inst* 91:1131, 1999.
1463. **Doherty JA, Cushing-Haugen KL, Saltzman BS, Voigt LF, Hill DA, Beresford SA, Chen C, Weiss NS**, Long-term use of postmenopausal estrogen and progestin hormone therapies and the risk of endometrial cancer, *Am J Obstet Gynecol* 197:139.e1, 2007.
1464. **Flowers CE, Wilborn WH, Hyde BM**, Mechanisms of uterine bleeding in postmenopausal patients receiving estrogen alone or with a progestin, *Obstet Gynecol* 61:135, 1983.
1465. **Hill DA, Weiss NS, Beresford SA, Voigt LF, Daling JR, Stanford JL, Self S**, Continuous combined hormone replacement therapy and risk of endometrial cancer, *Am J Obstet Gynecol* 183:1456, 2000.
1466. **Anderson GL, Judd HL, Kaunitz AM, Barad DH, Beresford SAA, Pettinger M, Liu J, McNeeley SG, Lopez AM; for the Women's Health Initiative Investigators**, Effects of estrogen plus progestin on gynecologic cancers and associated diagnostic procedures. The Women's Health Initiative Randomized Trial, *JAMA* 290:1739, 2003.
1467. **Fournier A, Dossus L, Mesrine S, Vilier A, Boutron-Ruault MC, Clavel-Chapelon F, Chabbert-Buffet N**, Risks of endometrial cancer associated with different hormone replacement therapies in the E3N cohort, 1992–2008, *Am J Epidemiol* 180(5):508, 2014.
1468. **Rodriguez C, Patel AV, Calle EE, Jacob EJ, Thun MJ**, Estrogen replacement therapy and ovarian cancer mortality in a large prospective study of US women, *JAMA* 285:1460, 2001.
1469. **Lacey JV Jr, Mink PJ, Lubin JH, Sherman ME, Troisi R, Hartge P, Schatzkin A, Schairer C**, Menopausal hormone replacement therapy and risk of ovarian cancer, *JAMA* 288:334, 2002.
1470. **Folsom AR, Anderson JP, Ross JA**, Estrogen replacement therapy and ovarian cancer, *Epidemiology* 15:100, 2004.
1471. **Lacey JV Jr, Brinton LA, Letizzmann MF, Mouw T, Hollenbeck A, Schatzkin A, Hartge P**, Menopausal hormone therapy and ovarian cancer risk in the National Institutes of Health—AARP Diet and Health Study Cohort, *J Natl Cancer Inst* 98:1397, 2006.
1472. **Danforth KN, Tworoger SS, Hecht JL, Rosner BA, Colditz GA, Hankinson SE**, A prospective study of postmenopausal hormone use and ovarian cancer risk, *Br J Cancer* 96:151, 2007.
1473. **Million Women Study Collaborators**, Ovarian cancer and hormone replacement therapy in the Million Women Study, *Lancet* 369:1703, 2007.
1474. **Mørch LS, Løkkegaard E, Andreassen AH, Krüger-Kjaer S, Lidegaard Ø**, Hormone therapy and ovarian cancer, *JAMA* 302:298, 2009.
1475. **Riman T, Dickman PW, Nilsson S, Correia N, Nordlinder H, Magnusson CM, Weiderpass E, Persson IR**, Hormone replacement therapy and the risk of invasive epithelial ovarian cancer in Swedish women, *J Natl Cancer Inst* 94:497, 2002.
1476. **Whittemore AS, Harris R, Itnyre J; the Collaborative Ovarian Cancer Group**, Characteristics relating to ovarian cancer risk: collaborative analysis of 12 US case-control studies. II: Invasive epithelial ovarian cancers in white women, *Am J Epidemiol* 136:1184, 1992.



1477. **Garg PP, Kerlikowske K, Subak L, Grady D**, Hormone replacement therapy and the risk of epithelial ovarian carcinoma: a meta-analysis, *Obstet Gynecol* 92:472, 1998.
1478. **Coughlin SS, Giustozzi A, Smith SJ, Lee NC**, A meta-analysis of estrogen replacement therapy and risk of epithelial ovarian cancer, *J Clin Epidemiol* 53:367, 2000.
1479. **Hempling RE, Wong C, Piver MS, Natarajan N, Mettlin CJ**, Hormone replacement therapy as a risk factor for epithelial ovarian cancer: results of a case-control study, *Obstet Gynecol* 89:1012, 1997.
1480. **Risch HA**, Estrogen replacement therapy and risk of epithelial ovarian cancer, *Gynecol Oncol* 63:254, 1996.
1481. **Sit ASY, Modugno F, Weissfeld JL, Berga SL, Ness RB**, Hormone replacement therapy formulations and risk of epithelial ovarian carcinoma, *Gynecol Oncol* 86:118, 2002.
1482. **Rossing MA, Cushing-Haugen KL, Wicklund KG, Doherty JA, Weiss NS**, Menopausal hormone therapy and risk of epithelial ovarian cancer, *Cancer Epidemiol Biomarkers Prev* 16:2548, 2007.
1483. **Whiteman DC, Siskind V, Purdie DM, Green AC**, Timing of pregnancy and the risk of epithelial ovarian cancer, *Cancer Epidemiol Biomarkers Prev* 12:42, 2003.
1484. **Yang CY, Kuo HW, Chiu HF**, Age at first birth, parity, and risk of death from ovarian cancer in Taiwan: a country of low incidence of ovarian cancer, *Int J Gynecol Cancer* 17:32, 2007.
1485. **Siskind V, Green A, Bain C, Purdie D**, Breastfeeding, menopause, and epithelial ovarian cancer, *Epidemiology* 8:188, 1997.
1486. **Green A, Purdie D, Bain C, Siskind V, Russell P, Quinn M, Ward B**, Tubal sterilisation, hysterectomy and decreased risk of ovarian cancer, Survey of Women's Health Study Group, *Int J Cancer* 71:948, 1997.
1487. **Fairfield KM, Hunter DJ, Fuchs CS, Colditz GA, Hankinson SE**, Aspirin, other NSAIDs, and ovarian cancer risk (United States), *Cancer Causes Control* 13:535, 2002.
1488. **Greer JB, Modugno F, Ness RB, Allen GO**, Anthropometry and the risk of epithelial ovarian cancer, *Cancer* 106:2247, 2006.
1489. **Olsen CM, Green AC, Whiteman DC, Sadeghi S, Kolahdooz F, Webb PM**, Obesity and the risk of epithelial ovarian cancer: a systematic review and meta-analysis, *Eur J Cancer* 43:690, 2007.
1490. **Ness RB, Cramer DW, Goodman MT, Kjaer SK, Mallin K, Mosgaard BJ, Purdie DM, Risch HA, Vergona R, Wu AH**, Infertility, fertility drugs, and ovarian cancer: a pooled analysis of case-control studies, *Am J Epidemiol* 155:217, 2002.
1491. **Goodman MT, Tung KH**, Alcohol consumption and the risk of borderline and invasive ovarian cancer, *Obstet Gynecol* 101:1221, 2003.
1492. **Suzuki R, Ye W, Rylander-Rudqvist T, Saji S, Colditz GA, Wolk A**, Alcohol and postmenopausal breast cancer risk defined by estrogen and progesterone receptor status: a prospective cohort study, *J Natl Cancer Inst* 97(21):1601, 2005.
1493. **Green A, Purdie D, Bain C, Siskind V, Webb PM**, Cigarette smoking and risk of epithelial ovarian cancer (Australia), *Cancer Causes Control* 12:713, 2001.
1494. **Goodman MT, Tung KH**, Active and passive tobacco smoking and the risk of borderline and invasive ovarian cancer (United States), *Cancer Causes Control* 14:569, 2003.
1495. **Jordan SJ, Whiteman DC, Purdie DM, Green AC, Webb PM**, Does smoking increase risk of ovarian cancer? A systematic review, *Gynecol Oncol* 103:1122, 2006.
1496. **Modesitt SC, Tortolero-Luna G, Robinson JB, Gershenson DM, Wolf JK**, Ovarian and extraovarian endometriosis-associated cancer, *Obstet Gynecol* 100:788, 2002.
1497. **Purdie DW, Bain CJ, Siskind V, Russell P, Hacker NF, Ward BG, Quinn MA, Green AC**, Hormone replacement therapy and risk of epithelial ovarian cancer, *Br J Cancer* 81:559, 1999.
1498. **Eeles RA, Tan S, Whitelaw E, Fryatt I, A'Hern RP, Shepherd JH, Harmer CL, Blake PR, Chilvers CED**, Hormone replacement therapy and survival after surgery for ovarian cancer, *Br Med J* 302:259, 1991.
1499. **Guidozzi F, Daponte A**, Estrogen replacement therapy for ovarian carcinoma survivors. A randomized controlled trial, *Cancer* 86:1013, 1999.
1500. **Ursic-Vrscaj M, Bebar S, Zakelj MP**, Hormone replacement therapy after invasive ovarian serous cystadenocarcinoma treatment: the effect on survival, *Menopause* 8:70, 2001.
1501. **Hopkins ML, Fung MF, Le T, Shorr R**, Ovarian cancer patients and hormone replacement therapy: a

systematic review, *Gynecol Oncol* 92:827, 2004.

1502. **Sturdee DW, Pines A; International Menopause Society Writing Group; Archer DF, Baber RJ, Barlow D, Birkhäuser MH, Brincat M, Cardozo L, de Villiers TJ, Gambacciani M, Gompel AA, Henderson VW, Kluff C, Lobo RA, MacLennan AH, Marsden J, Nappi RE, Panay N, Pickar JH, Robinson D, Simon J, Sitruk-Ware RL, Stevenson JC**, Updated IMS recommendations on postmenopausal hormone therapy and preventive strategies for midlife health, *Climacteric* 14(3):302, 2011.
1503. **Chute CG, Willett WC, Colditz GA, Stampfer MJ, Rosner B, Speizer FE**, A prospective study of reproductive history and exogenous estrogens on the risk of colorectal cancer in women, *Epidemiology* 2:201, 1991.
1504. **Jacobs EJ, White E, Weiss NS**, Exogenous hormones, reproductive history, and colon cancer, *Cancer Causes Control* 5:359, 1994.
1505. **Calle EE, Miracle-McMahill ML, Thun MJ, Heath CW Jr**, Estrogen replacement therapy and risk of fatal colon cancer in a prospective cohort of postmenopausal women, *J Natl Cancer Inst* 87:517, 1995.
1506. **Kampman E, Potter JD, Slattery ML, Caan BJ, Edwards S**, Hormone replacement therapy, reproductive history, and colon cancer: a multicenter, case-control study in the United States, *Cancer Causes Control* 8:146, 1997.
1507. **Troisi R, Schairer C, Chow W-H, Schatzkin A, Brinton LA, Fraumeni JF Jr**, A prospective study of menopausal hormones and risk of colorectal cancer (United States), *Cancer Causes Control* 8:130, 1997.
1508. **Fernandez E, La Vecchia C, Braga C, Talamini R, Negri E, Parazzini F, Franceschi S**, Hormone replacement therapy and risk of colon and rectal cancer, *Cancer Epidemiol Biomarkers Prev* 7:329, 1998.
1509. **Paganini-Hill A**, Estrogen replacement therapy and colorectal cancer risk in elderly women, *Dis Colon Rectum* 42:1300, 1999.
1510. **Johnson JR, Lacey JV Jr, Lazovich D, Geller MA, Schairer C, Schatzkin A, Flood A**, Menopausal hormone therapy and risk of colorectal cancer, *Cancer Epidemiol Biomarkers Prev* 18:196, 2009.
1511. **Rennert G, Rennert HS, Pinchev M, Lavie O, Gruber SB**, Use of hormone replacement therapy and the risk of colorectal cancer, *J Clin Oncol* 27:4542, 2009.
1512. **Grodstein F, Martinez E, Platz EA, Giovannucci E, Colditz GA, Kautsky M, Fuchs C, Stampfer MJ**, Postmenopausal hormone use and risk for colorectal cancer and adenoma, *Ann Intern Med* 128:705, 1998.
1513. **Chan JA, Meyerhardt JA, Chan AT, Giovannucci EL, Colditz GA, Fuchs CS**, Hormone replacement therapy and survival after colorectal diagnosis, *J Clin Oncol* 36:5680, 2006.
1514. **Yang G, Shu XO, Li H, Chow WH, Cai H, Zhang X, Gao YT, Zheng W**, Prospective cohort study of soy food intake and colorectal cancer risk in women, *Am J Clin Nutr* 89:577, 2009.
1515. **Ritenbaugh C, Stanford JL, Wu L, Shikany JM, Schoen RE, Stefanick ML, Taylor V, Garland C, Frank G, Lande D, Mason E, McNeeley SG, Ascensao J, Chlebowski RT; Women's Health Initiative Investigators**, Conjugated equine estrogens and colorectal cancer incidence and survival: the Women's Health Initiative randomized clinical trials, *Cancer Epidemiol Biomarkers Prev* 17:2609, 2008.
1516. **Delellis Henderson K, Duan L, Sullivan-Halley J, Ma H, Clarke CA, Neuhausen SL, Templeman C, Bernstein L**, Menopausal hormone therapy use and risk of invasive colon cancer: the California Teachers Study, *Am J Epidemiol* 171:415, 2010.
1517. **Csizmadi I, Collet JP, Benedetti A, Boivin JF, Hanley JA**, The effects of transdermal and oral oestrogen replacement therapy on colorectal cancer risk in postmenopausal women, *Br J Cancer* 90:76, 2004.
1518. **Chlebowski RT, Schwartz AG, Wakelee H, Anderson GL, Stefanick ML, Manson JE, Rodabough RJ, Chien JW, Wactawski-Wende J, Gass M, Kotchen JM, Johnson KC, O'Sullivan MJ, Ockene JK, Chen C, Hubbell FA; for the Women's Health Initiative Investigators**, Oestrogen plus progestin and lung cancer in postmenopausal women (Women's Health Initiative Trial): a post-hoc analysis of a randomised controlled trial, *Lancet* 374(9697):1243, 2009. doi: 10.1016/S0140-6736(09)61526-9.
1519. **Stabile LP, Davis AL, Gubish CT, Hopkins TM, Luketich JD, Christie N, Finkelstein S, Siegfried JM**, Human non-small cell lung tumors and cells derived from normal lung express both estrogen receptor alpha and beta and show biological responses to estrogen, *Cancer Res* 62:2141, 2002.
1520. **Blackman JA, Coogan PF, Rosenberg L, Strom BL, Zauber AG, Palmer JR, Langenberg P, Shapiro**

- S, Estrogen replacement therapy and risk of lung cancer, *Pharmacoepidemiol Drug Saf* 11:561, 2002.
1521. **Schabath MB, Wu X, Vassilopoulou-Sellin R, Vaporciyan AA, Spitz MR**, Hormone replacement therapy and lung cancer risk: a case-control analysis, *Clin Cancer Res* 10:113, 2004.
1522. **Chen KY, Hsiao CF, Chang GC, Tsai YH, Su WC, Perng RP, Huang MS, Hsiung CA, Chen CJ, Yang PC; GEFLAC Study Group**, Hormone replacement therapy and lung cancer risk in Chinese, *Cancer* 110:1768, 2007.
1523. **Rodriguez C, Spencer Feigelson H, Deka A, Patel AV, Jacobs EJ, Thun MJ, Calle EE**, Postmenopausal hormone therapy and lung cancer risk in the cancer prevention study II nutrition cohort, *Cancer Epidemiol Biomarkers Prev* 17:655, 2008.
1524. **Schwartz AG, Wenzlaff AS, Prysak GM, Murphy V, Cote ML, Brooks SC, Skafar DF, Lonardo F**, Reproductive factors, hormone use, and estrogen receptor expression and risk of non small-cell lung cancer in women, *J Clin Oncol* 25:5785, 2007.
1525. **Kreuzer M, Gerken M, Heinrich J, Kreienbrock L, Wichmann HE**, Hormonal factors and risk of lung cancer among women?, *Int J Epidemiol* 32:263, 2003.
1526. **Olsson H, Bladström A, Ingvar C**, Are smoking-associated cancers prevented or postponed in women using hormone replacement therapy?, *Obstet Gynecol* 102:565, 2003.
1527. **Ganti AK, Sahmoun AE, Panwalkar AW, Tendulkar KK, Potti A**, Hormone replacement therapy is associated with decreased survival in women with lung cancer, *J Clin Oncol* 24:59063, 2006.
1528. **Huang B, Carloss H, Wyatt SW, Riley E**, Hormone replacement therapy and survival in lung cancer in postmenopausal women in a rural population, *Cancer* 115:4167, 2009.
1529. **Ayeni O, Robinson A**, Hormone replacement therapy and outcomes for women with non-small-cell lung cancer: can an association be confirmed?, *Curr Oncol* 16:21, 2009.
1530. **Hershberger PA, Vasquez AC, Kanterewicz B, Land S, Siegfried JM, Nichols M**, Regulation of endogenous gene expression in human non-small cell lung cancer cells by estrogen receptor ligands, *Cancer Res* 65:1598, 2005.
1531. **Márquez-Garbán DC, Chen HW, Goodglick L, Fishbein MC, Pietras RJ**, Targeting aromatase and estrogen signaling in human non-small cell lung cancer, *Ann N Y Acad Sci* 1155:194, 2009.
1532. **Smith JR, Barrett-Connor E, Kritz-Silverstein D, Wingard DL, Al-Delaimy WK**, Hormone use and lung cancer incidence: the Rancho Bernardo cohort study, *Menopause* 16:1044, 2009.
1533. **Adami H-O, Persson I, Hoover R, Schairer C, Bergkvist L**, Risk of cancer in women receiving hormone replacement therapy, *Int J Cancer* 44:833, 1989.
1534. **Parazzini F, La Vecchia C, Negri E, Franceschi S, Moroni S, Chatenoud L, Bolis G**, Case-control study of oestrogen replacement therapy and risk of cervical cancer, *Br Med J* 315:85, 1997.
1535. **Lacey JV Jr, Brinton LA, Barnes WA, Gravitt PE, Greenberg MD, Hadjimichael OC, Hadjimichael OC, McGowen L, Mortel R, Schwartz PE, Kurman RJ, Hildesheim A**, Use of hormone replacement therapy and adenocarcinomas and squamous cell carcinomas of the uterine cervix, *Gynecol Oncol* 77:149, 2000.
1536. **Ploch E**, Hormonal replacement therapy in patients after cervical cancer treatment, *Gynecol Oncol* 26:169, 1987.
1537. **Green A**, Oral contraceptives and skin neoplasia, *Contraception* 43:653, 1991.
1538. **Hannaford PC, Villard-Mackintosh L, Vessey MP, Kay CR**, Oral contraceptives and malignant melanoma, *Br J Cancer* 63:430, 1991.
1539. **Osterlind A, Tucker MA, Stone BJ, Jensen OM**, The Danish case-control study of cutaneous malignant melanoma. III. Hormonal and reproductive factors in women, *Int J Cancer* 42:821, 1988.
1540. **Holly EA, Cress RD, Ahn DK**, Cutaneous melanoma in women: ovulatory life, menopause, and use of exogenous hormones, *Cancer Epidemiol Biomarkers Prev* 3:661, 1994.
1541. **White E, Kirkpatrick CS, Lee JAH**, Case-control study of malignant melanoma in Washington State. I. Constitutional factors and sun exposure, *Am J Epidemiol* 139:857, 1994.
1542. **Smith MA, Fine JA, Barnhill RL, Berwick M**, Hormonal and reproductive influences and risk of melanoma in women, *Int J Epidemiol* 27:751, 1998.

1543. **Lea CS, Holly EA, Hartge P, Lee JS, Guerry IV D, Elder DE, Halpern A, Sagebiel RW, Tucker MA,** Reproductive risk factors for cutaneous melanoma in women: a case-control study, *Am J Epidemiol* 65:505, 2007.
1544. **Holman CDJ, Armstrong BK, Heenan PJ,** Cutaneous malignant melanoma in women: exogenous sex hormones and reproductive factors, *Br J Cancer* 50:673, 1984.
1545. **Koomen ER, Joosse A, Herings RM, Casparie MK, Guchelaar HJ, Nijsten T,** Estrogens, oral contraceptives and hormonal replacement therapy increase the incidence of cutaneous melanoma: a population-based case-control study, *Ann Oncol* 20:358, 2009.
1546. **Glueck CJ, Lang J, Hamer T, Tracy T,** Severe hypertriglyceridemia and pancreatitis when estrogen replacement therapy is given to hypertriglyceridemic women, *J Lab Clin Med* 123:59, 1994.
1547. **Goldenberg NM, Wang P, Glueck CJ,** An observational study of severe hypertriglyceridemia, hypertriglyceridemic acute pancreatitis, and failure of triglyceride-lowering therapy when estrogens are given to women with and without familial hypertriglyceridemia, *Clin Chim Acta* 332:11, 2003.
1548. **Grodstein F, Colditz GA, Stampfer MJ,** Postmenopausal hormone use and cholecystectomy in a large prospective study, *Obstet Gynecol* 83:5, 1994.
1549. **Petitti DB, Sidney S, Perlman JA,** Increased risk of cholecystectomy in users of supplemental estrogen, *Gastroenterology* 94:91, 1988.
1550. **La Vecchia C, Negri E, D'Avanzo B, Parazzini F, Genitle A, Franceschi S,** Oral contraceptives and noncontraceptive oestrogens in the risk of gallstone disease requiring surgery, *J Epidemiol Community Health* 46:234, 1992.
1551. **Scragg RK, McMichael AJ, Seamark RF,** Oral contraceptives, pregnancy and endogenous estrogen in gallstone disease—a case-control study, *Br Med J* 288:1795, 1984.
1552. **Kakar F, Weiss NS, Strite SA,** Non-contraceptive estrogen use and the risk of gallstone disease in women, *Am J Public Health* 78:564, 1988.
1553. **Jorgensen T,** Gallstones in a Danish population: fertility, period, pregnancies, and exogenous female sex hormones, *Gut* 29:433, 1988.
1554. **Simon JA, Hunninghake DB, Agarwal SK, Lin F, Cauley JA, Ireland CC, Pickar JH; for the Heart and Estrogen/progestin Replacement Study (HERS) Research Group,** Effect of estrogen plus progestin on risk for biliary tract surgery in postmenopausal women with coronary artery disease, *Ann Intern Med* 135:493, 2001.
1555. **Cirillo DJ, Wallace RB, Rodabough RJ, Greenland P, LaCroix AZ, Limacher MC, Larson JC,** Effect of estrogen therapy on gallbladder disease, *JAMA* 293:330, 2005.
1556. **van Erpecum KJ, van Berge Henegouwen GP, Verschoor L, Stoelwinder B, Willekens FLH,** Different hepatobiliary effects of oral and transdermal estradiol in postmenopausal women, *Gastroenterology* 100:482, 1991.
1557. **Uhler ML, Marks JW, Voigt BJ, Judd HL,** Comparison of the impact of transdermal versus oral estrogens on biliary markers of gallstone formation in postmenopausal women, *J Clin Endocrinol Metab* 83:410, 1998.
1558. **Liu B, Beral V, Balkwill A, Green JR, Sweetland S, Reeves G; Million Women Study Collaborators,** Gallbladder disease and use of transdermal versus oral hormone replacement therapy in postmenopausal women: prospective cohort study, *Br Med J* 337:a386, 2008. doi: 10.1131/bmj.a386.
1559. **Crawford SL, Casey VA, Avis NE, McKinlay SM,** A longitudinal study of weight and the menopause transition: results from the Massachusetts Women's Health Study, *Menopause* 7:96, 2000.
1560. **Blumel JE, Castelo-Branco C, Rocagliolo ME, Bifa L, Tacla X, Mamani L,** Changes in body mass index around menopause: a population study of Chilean women, *Menopause* 8:239, 2001.
1561. **Kritz-Silverstein D, Barrett-Connor E,** Long-term postmenopausal hormone use, obesity, and fat distribution in older women, *JAMA* 27:46, 1996.
1562. **Espeland MA, Stefanick ML, Kritz-Silverstein D, Fineberg SE, Waclawiw MA, James MK, Greendale GA; for the Postmenopausal Estrogen/Progestin Interventions Study Investigators,** Effect of postmenopausal hormone therapy on body weight and waist and hip girths, *J Clin Endocrinol Metab* 82:1549, 1997.

1563. **Thornycroft IH, Lindsay R, Pickar JH**, Body composition during treatment with conjugated estrogens with and without medroxyprogesterone acetate: analysis of the Women's Health, Osteoporosis, Progestin, Estrogen (HOPE) Trial, *Am J Obstet Gynecol* 197:137.e1, 2007.
1564. **Sowers M, Zheng H, Tomey K, Karvonen-Gutierrez C, Jannausch ML, Li X, Yosef M, Symons J**, Changes in body composition in women over six years at midlife: ovarian and chronological aging, *J Clin Endocrinol Metab* 92:895, 2007.
1565. **Salpeter SR, Walsh JME, Ormiston TM, Greyber E, Buckley NS, Salpeter EE**, Meta-analysis: effect of hormone therapy on components of the metabolic syndrome in postmenopausal women, *Diabetes Obes Metab* 8:538, 2006.
1566. **Gambacciani M, Ciaponi M, Cappagli B, De Simone L, Orlandi R, Genazzani AR**, Prospective evaluation of body weight and body fat distribution in early postmenopausal women with and without hormonal replacement therapy, *Maturitas* 39:125, 2001.
1567. **Jensen LB, Vestergaard P, Hermann AP, Gram J, Eiken P, Abrahamsen B, Brot C, Kolthoff N, Sorensen OH, Beck-Nielsen H, Nielsen SP, Charles P, Mosekilde L**, Hormone replacement therapy dissociates fat mass and bone mass, and tends to reduce weight gain in early postmenopausal women: a randomized, controlled 5-year clinical trial of the Danish Osteoporosis Prevention Study, *J Bone Miner Res* 18:333, 2003.
1568. **Chen Z, Bassford T, Green SB, Cauley JA, Jackson RD, LaCroix AZ, Leboff M, Stefanick ML, Margolis KL**, Postmenopausal hormone therapy and body composition—a substudy of the estrogen plus progestin trial of the Women's Health Initiative, *Am J Clin Nutr* 82:651, 2005.
1569. **Arabi A, Garnero P, Porcher R, Pelissier C, Benhamou CL, Roux C**, Changes in body composition during post-menopausal hormone therapy: a 2 year prospective study, *Hum Reprod* 18:1747, 2003.
1570. **Creasman WT**, Estrogen replacement therapy: is previously treated cancer a contraindication?, *Obstet Gynecol* 77:308, 1991.
1571. **Lee RB, Burke TW, Park RC**, Estrogen replacement therapy following treatment for stage 1 endometrial carcinoma, *Gynecol Oncol* 36:189, 1990.
1572. **Baker DP**, Estrogen-replacement therapy in patients with previous endometrial carcinoma, *Compr Ther* 16:28, 1990.
1573. **Chapman JA, DiSaia PJ, Osann K, Roth PD, Gillotte DL, Berman ML**, Estrogen replacement in surgical stage I and II endometrial cancer survivors, *Am J Obstet Gynecol* 175:1195, 1996.
1574. **Suriano KA, McHale M, McLaren C, Li K-T, Re A, DiSaia PJ**, Estrogen replacement therapy in endometrial cancer patients: a matched cohort study, *Obstet Gynecol* 97:555, 2001.
1575. **Ayhan A, Taskiran C, Simsek S, Sever A**, Does immediate hormone replacement therapy affect the oncologic outcome in endometrial cancer survivors?, *Int J Gynecol Cancer* 16:805, 2006.
1576. **Barakat RR, Bundy BN, Spirtos NM, Bell J, Mannel RS; Gynecologic Oncology Group Study**, Randomized double-blind trial of estrogen replacement therapy versus placebo in stage I or II endometrial cancer: a Gynecologic Oncology Group Study, *J Clin Oncol* 24:587, 2006.
1577. **Reimnitz C, Brand E, Nieberg RK, Hacker NF**, Malignancy arising in endometriosis associated with unopposed estrogen replacement, *Obstet Gynecol* 71:444, 1988.
1578. **Heaps JM, Nieberg RK, Berek JS**, Malignant neoplasms arising in endometriosis, *Obstet Gynecol* 75:1023, 1990.
1579. **Duun S, Roed-Petersen K, Michelsen JW**, Endometrioid carcinoma arising from endometriosis of the sigmoid colon during estrogenic treatment, *Acta Obstet Gynecol Scand* 72:676, 1993.
1580. **Namnoum AB, Hickman TN, Goodman SB, Gehlbach DL, Rock JA**, Incidence of symptom recurrence after hysterectomy for endometriosis, *Fertil Steril* 64:898, 1995.
1581. **Gucer F, Pieber D, Arikan MG**, Malignancy arising in extraovarian endometriosis during estrogen stimulation, *Eur J Gynaecol Oncol* 19:39, 1998.
1582. **Leiserowitz GS, Gumbs JL, Oi R, Dalrymple JL, Smith LH, Ryu J, Scudder S, Russell AH**, Endometriosis-related malignancies, *Int J Gynecol Cancer* 13:466, 2003.
1583. **Spicer D, Pike MC, Henderson BE**, The question of estrogen replacement therapy in patients with a prior

diagnosis of breast cancer, *Oncology* 4:49, 1990.

1584. **Stoll W**, Phytotherapy influences atrophic vaginal epithelium, *Therapeutikon* 1:23, 1987.
1585. **Powles TJ, Hickish T, Casey S, O'Brien M**, Hormone replacement after breast cancer, *Lancet* 342:60, 1993.
1586. **Wile AG, Opfell RW, Margileth DA**, Hormone replacement therapy in previously treated breast cancer patients, *Am J Surg* 165:372, 1993.
1587. **DiSaia PJ, Odicino F, Groesen EA, Cowan B, Pecorelli S, Wile AG**, Hormone replacement therapy in breast cancer (letter), *Lancet* 342:1232, 1993.
1588. **DiSaia PJ, Groesen EA, Kurosaki T, Gildea M, Cowan B, Anton-Culver H**, Hormone replacement therapy in breast cancer survivors: a cohort study, *Am J Obstet Gynecol* 174:1494, 1996.
1589. **Vassilopoulou-Sellin R, Theriault R, Klein MJ**, Estrogen replacement therapy in women with prior diagnosis and treatment for breast cancer, *Gynecol Oncol* 65:89, 1997.
1590. **Vassilopoulou-Sellin R, Asmar L, Hortobagyi GN, Klein MJ, McNeese M, Singletary SE, Theriault RL**, Estrogen replacement therapy after localized breast cancer: clinical outcome of 319 women followed prospectively, *J Clin Oncol* 17:1482, 1999.
1591. **Decker DA, Pettinga JE, Cox TC, Burdakin JH, Jaiyesimi IA, Benitez PR**, Hormone replacement therapy in breast cancer survivors, *Breast J* 3:63, 1997.
1592. **Dew J, Eden JA, Beller E, Magarey C, Schwartz P, Crea P, Wren BG**, A cohort study of hormone replacement therapy given to women previously treated for breast cancer, *Climacteric* 1:137, 1998.
1593. **Ursic-Vrscaj M, Bebar S**, A case-control study of hormone replacement therapy after primary surgical breast cancer treatment, *Eur J Surg Oncol* 25:146, 1999.
1594. **Guidozzi F**, Estrogen replacement therapy in breast cancer survivors, *Int J Gynaecol Obstet* 69:101, 2000.
1595. **DiSaia PJ, Brewster WR, Ziogas A, Anton-Culver H**, Breast cancer survival and hormone replacement therapy: a cohort analysis, *Am J Clin Oncol* 23:541, 2000.
1596. **Marttunen MB, Hietanen P, Pyrhönen S, Tiitinen A, Ylikorkala O**, A prospective study on women with a history of breast cancer and with or without estrogen replacement therapy, *Maturitas* 39:217, 2001.
1597. **Peters GN, Fodera T, Sabol J, Jones S, Euhus D**, Estrogen replacement therapy after breast cancer: a 12-year follow-up, *Ann Surg Oncol* 8:828, 2001.
1598. **Beckmann MW, Jap D, Djahansouzi S, Nestle-Krämling C, Kuschel B, Dall P, Brumm C, Bender HG**, Hormone replacement therapy after treatment of breast cancer: effects on postmenopausal symptoms, bone mineral density and recurrence rates, *Oncology* 60:199, 2001.
1599. **Puthugramam K, Gambrell RD Jr**, Estrogen replacement therapy in patients with early breast cancer, *Am J Obstet Gynecol* 187:289, 2002.
1600. **Decker DA, Pettinga JE, VanderVelde N, Huang RR, Kestin L, Burdakin JH**, Estrogen replacement therapy in breast cancer survivors: a matched-controlled series, *Menopause* 10:277, 2003.
1601. **O'Meara ES, Rossing MA, Daling JR, Elmore JG, Barlow WE, Weiss NS**, Hormone replacement therapy after a diagnosis of breast cancer in relation to recurrence and mortality, *J Natl Cancer Inst* 93:754, 2001.
1602. **Vassilopoulou-Sellin R, Theriault RL**, Randomized prospective trial of estrogen replacement therapy in women with a history of breast cancer, *J Natl Cancer Inst* 16:153, 1994.
1603. **Vassilopoulou-Sellin R, Cohen DS, Hortobagyi GN, Klein MJ, McNeese M, Singletary SE, Smith TL, Theriault RL**, Estrogen replacement therapy for menopausal women with a history of breast carcinoma: results of a 5-year, prospective study, *Cancer* 95:1817, 2002.
1604. **Figueiredo JC, Bernstein L, Capanu M, Malone KE, Lynch CF, Anton-Culver H, Stovall M, Bertelsen L, Haile RW, Bernstein JL**, Oral contraceptives, postmenopausal hormones, and risk of asynchronous bilateral breast cancer: the WECARE Study Group, *J Clin Oncol* 26:1411, 2008.
1605. **Holmberg L, Anderson H**; for the **HABITS steering and data monitoring committees**, HABITS (hormonal replacement therapy after breast cancer—is it safe?), a randomized comparison: trial stopped, *Lancet* 363:453, 2004.
1606. **Holmberg L, Iversen O-E, Rudenstam CM, Hammar M, Kumpulainen E, Jaskiewicz J, Jassem J**,

- Dobaczewska D, Fjosne HE, Peralta O, Arriagada R, Holmqvist M, Maenpa J;** on behalf of the **HABITS Study Group**, Increased risk of recurrence after hormone replacement therapy in breast cancer survivors, *J Natl Cancer Inst* 100:475, 2008.
1607. **von Schoultz E, Rutqvist LE; Stockholm Breast Cancer Study Group**, Menopausal hormone therapy after breast cancer: the Stockholm Randomized Trial, *J Natl Cancer Inst* 97:533, 2005.
1608. **Samaras K, Kelly RP, Hayward CS, Campbell LV, Sullivan D**, Effects of postmenopausal hormone replacement therapy on central abdominal fat, glycemic control, lipid metabolism, and vascular factors in type 2 diabetes, *Diabetes Care* 22:1401, 1999.
1609. **Cornu C, Mercier C, French P, Bully C, Pugeat M, Cousin P, Rious JP, Bajart L, Orgiazzi J, Pomet-Nicot C, Darsy P, Boissel JP, Berthezene F**, Postmenopause hormone treatment in women with NIDDM or impaired glucose tolerance: the MEDIA randomized clinical trial, *Maturitas* 37:95, 2000.
1610. **Darko DA, Dornhorst A, Kennedy G, Mandeno RC, Seed M**, Glycaemic control and plasma lipoproteins in menopausal women with Type 2 diabetes treated with oral and transdermal combined hormone replacement therapy, *Diabetes Res Clin Pract* 54:157, 2001.
1611. **Ferrara A, Liu JY, Karter AJ, Selby JV, Ackerson LM**, Hormone replacement therapy is associated with better glycemic control in women with type 2 diabetes, *Diabetes Care* 24:1144, 2001.
1612. **Fenkci S, Fenkci V, Yilmazer M, Serteser M, Koken T**, Effects of short-term transdermal hormone replacement therapy on glycaemic control, lipid metabolism, C-reactive protein and proteinuria in postmenopausal women with type 2 diabetes or hypertension, *Hum Reprod* 18:866, 2003.
1613. **Ferrara A, Quesenberry CP, Karter AJ, Njoroge CW, Jacobson AS, Selby JV; Northern California Kaiser Permanente Diabetes Registry**, Current use of unopposed estrogen and estrogen plus progestin and the risk of acute myocardial infarction among women with diabetes: the Northern California Kaiser Permanente Diabetes Registry, 1995–1998, *Circulation* 107:43, 2003.
1614. **Cagnacci A, Paoletti AM, Zanni A, Arangino S, Ibba G, Orru M, Melis GB, Volpe A**, Raloxifene does not modify insulin sensitivity and glucose metabolism in postmenopausal women, *J Clin Endocrinol Metab* 87:4117, 2002.
1615. **Cucinelli F, Soranna L, Romualdi D, Muzj G, Mancuso S, Lanzone A**, The effect of raloxifene on glyco-insulinemic homeostasis in healthy postmenopausal women: a randomized placebo-controlled study, *J Clin Endocrinol Metab* 87:4186, 2002.
1616. **Crippin JS, Jorgensen RA, Dickson ER, Lindor KD**, Hepatic osteodystrophy in primary biliary cirrhosis: effects of medical treatment, *Am J Gastroenterol* 89:47, 1994.
1617. **Menon KV, Angulo P, Boe GM, Landor KD**, Safety and efficacy of estrogen therapy in preventing bone loss in primary biliary cirrhosis, *Am J Gastroenterol* 98:889, 2003.
1618. **Ormarsdóttir S, Mallmin H, Naessén T, Petré-Mallmin M, Broomé U, Hultcrantz R, Lööf L**, An open, randomized, controlled study of transdermal hormone replacement therapy on the rate of bone loss in primary biliary cirrhosis, *J Intern Med* 256:63, 2004.
1619. **Codes L, Asselah T, Cazals-Hatem D, Tubach F, Vidaud D, Paraná R, Bedossa P, Valla D, Marcellin P**, Liver fibrosis in women with chronic hepatitis C: evidence for the negative role of the menopause and steatosis and the potential benefit of hormone replacement therapy, *Gut* 56:390, 2007.
1620. **Di Martino V, Lebray P, Myers RP, Pannier E, Paradis V, Charlotte F, Moussalli J, Thabut D, Buffet C, Poynard T**, Progression of liver fibrosis in women infected with hepatitis C: long-term benefit of estrogen exposure, *Hepatology* 40:1426, 2004.
1621. **Pietrzak B, Cyganek A, Jabiry-Zieniewicz Z, Bobrowska K, Durlik M, Oldakowska-Jedynak U, Binkowska M, Paczek L, Kaminski P**, Safety and efficacy of hormonal therapy in menopausal kidney-allograft recipients, *Transplant Proc* 38:184, 2006.
1622. **Frigo P, Eppel W, Asseryanis E, Sator M, Golaszewski T, Gruber D, Lang C, Huber J**, The effects of hormone substitution in depot form on the uterus in a group of 50 perimenopausal women—a vaginosonographic study, *Maturitas* 21:221, 1995.
1623. **Sener AB, Seçkin NC, Özmen S, Gökmen O, Dogu N, Ekici E**, The effects of hormone replacement therapy on uterine fibroids in postmenopausal women, *Fertil Steril* 65:354, 1996.

1624. **Schwartz LB, Lazer S, Mark M, Nachtigall LE, Horan C, Goldstein SR**, Does the use of postmenopausal hormone replacement therapy influence the size of uterine leiomyomata? A preliminary report, *Menopause* 3:38, 1996.
1625. **de Aloysio D, Altieri P, Penacchioni P, Salgarello M, Ventura V**, Bleeding patterns in recent postmenopausal outpatients with uterine myomas: comparison between two regimens of HRT, *Maturitas* 29:261, 1998.
1626. **Palomba S, Sena T, Noia R, Di Carlo C, Zullo F, Mastrantonio P**, Transdermal hormone replacement therapy in postmenopausal women with uterine leiomyomas, *Obstet Gynecol* 98:1053, 2001.
1627. **Palomba S, Sammartino A, Di Carlo C, Affinito P, Zullo F, Nappi C**, Effects of raloxifene treatment on uterine leiomyomas in postmenopausal women, *Fertil Steril* 76:38, 2001.
1628. **Palomba S, Orio F Jr, Morelli M, Russo T, Pellicano M, Zupi E, Lombardi G, Nappi C, Panici PL, Zullo F**, Raloxifene administration in premenopausal women with uterine leiomyomas: a pilot study, *J Clin Endocrinol Metab* 87:3603, 2002.
1629. **Siegle JC, Cartmell L**, Vulvar leiomyoma associated with estrogen/progestin therapy. A case report, *J Reprod Med* 40:147, 1995.
1630. **Schwartz SM, Weiss NS, Daling JR, Gammon MD, Liff JM, Watt J, Lynch CF, Newcomb PA, Armstrong BK, Thompson WD**, Exogenous sex hormone use correlates of endogenous hormone levels, and the incidence of histologic types of sarcoma of the uterus, *Cancer* 77:717, 1996.
1631. **Cistulli PA, Barnes DJ, Grunstein RR, Sullivan CE**, Effect of short term hormone replacement in the treatment of obstructive sleep apnea in postmenopausal women, *Thorax* 46:699, 1994.
1632. **Polo-Kantola P, Rauhala E, Helenius H, Erkkola R, Irjala K, Polo O**, Breathing during sleep in menopause: a randomized, controlled, crossover trial with estrogen therapy, *Obstet Gynecol* 102:68, 2003.
1633. **Keefe DL, Watson R, Naftolin F**, Hormone replacement therapy may alleviate sleep apnea in menopausal women: a pilot study, *Menopause* 6:196, 1999.
1634. **Manber R, Kuo TF, Cataldo NA, Colrain IM**, The effects of hormone replacement therapy on sleep-disordered breathing in postmenopausal women: a pilot study, *Sleep* 26:163, 2003.
1635. **Wesström J, Ulfberg J, Nilsson S**, Sleep apnea and hormone replacement therapy: a pilot study and a literature review, *Acta Obstet Gynecol Scand* 84:54, 2005.
1636. **Lieberman D, Kopernik G, Porath A, Lazer S, Heimer D**, Sub-clinical worsening of bronchial asthma during estrogen replacement therapy in asthmatic post-menopausal women, *Maturitas* 21:153, 1995.
1637. **Hepburn MJ, Dooley DP, Morris MJ**, The effects of estrogen replacement therapy on airway function in postmenopausal, asthmatic women, *Arch Intern Med* 161:2717, 2001.
1638. **Kos-Kudla B, Ostrowska Z, Marek B, Ciesielska-Kopacz N, Kajdaniuk DK, Kudła M**, Effects of hormone replacement therapy on endocrine and spirometric parameters in asthmatic postmenopausal women, *Gynecol Endocrinol* 15:304, 2001.
1639. **Troisi RJ, Speizer FE, Willett WC, Trichopoulos D, Rosner B**, Menopause, postmenopausal estrogen preparations and the risk of adult-onset asthma, *Am J Respir Crit Care Med* 152:1183, 1995.
1640. **Romieu I, Fabre A, Fournier A, Kauffmann F, Varraso R, Mesrine S, Leynaert B, Clavel-Chapelon F**, Postmenopausal hormone therapy and asthma onset in the E3N cohort, *Thorax* 65(4):292, 2010.
1641. **Barr RG, Wentowski CC, Grodstein F, Somers SC, Stampfer MJ, Schwartz J, Speizer FE, Camargo CA Jr**, Prospective study of postmenopausal hormone use and newly diagnosed asthma and chronic obstructive pulmonary disease, *Arch Intern Med* 164:379, 2004.
1642. **Shumaker SA, Legault C, Kuller L, Rapp SR, Thal L, Lane DS, Fillit H, Stefanick ML, Hendrix SL, Lewis CE, Masaki K, Coker LH; Women's Health Initiative Memory Study**, Conjugated equine estrogens and incidence of probable dementia and mild cognitive impairment in postmenopausal women: Women's Health Initiative Memory Study, *JAMA* 291:2947, 2004.
1643. **Steiger MJ, Quinn NP**, Hormone replacement therapy induced chorea, *Br Med J* 302:762, 1991.
1644. **Thomas JM**, Hormone-replacement therapy and pulmonary leiomyomatosis (Letter), *N Engl J Med* 327:1956, 1992.
1645. **Wetterberg L, Olsson MB, Alm-Agvald I**, Estrogen treatment caused acute attacks of porphyria,



Lakartidningen 92:2197, 1995.

1646. **Gurwood AS, Gurwood I, Gubman DT, Brzezicki LJ**, Idiosyncratic ocular symptoms associated with the estradiol transdermal estrogen replacement patch system, *Optom Vis Sci* 72:29, 1995.
1647. **Strachan D**, Sudden sensorineural deafness and hormone replacement therapy, *J Laryngol Otol* 110:1148, 1996.
1648. **Sharma R, Pickering J, McCormack WM**, Trichomoniasis in a postmenopausal women cured after discontinuation of estrogen replacement therapy, *Sex Trans Dis* 2:543, 1997.
1649. **Sartore A, Grimaldi E, Guaschino S**, The treatment of Sjögren's syndrome with tibolone: a case report, *Am J Obstet Gynecol* 189:894, 2003.
1650. **Vandenbroucke JP, Witteman JCM, Valkenburg HA, Boersma JW, Cats A, Festen JJM, Hartman AP, Huber-Bruning O, Rasker JJ, Weber J**, Noncontraceptive hormones and rheumatoid arthritis in perimenopausal and postmenopausal women, *JAMA* 255:1299, 1986.
1651. **Spector TD, Pregnan P, Harris P, Studd JWW, Silman AJ**, Does estrogen replacement therapy protect against rheumatoid arthritis?, *J Rheumatol* 18:1473, 1991.
1652. **Koepsell TD, Dugowson CE, Nelson JL, Voigt LF, Daling JR**, Non-contraceptive hormones and the risk of rheumatoid arthritis in menopausal women, *Int J Epidemiol* 23:1248, 1994.
1653. **Doran MF, Crowson CS, O'Fallon WM, Gabriel SE**, The effect of oral contraceptives and estrogen replacement therapy on the risk of rheumatoid arthritis: a population based study, *J Rheumatol* 31:207, 2004.
1654. **Hall GM, Daniels M, Huskisson ES, Spector TD**, A randomised controlled trial of the effect of hormone replacement therapy on disease activity in postmenopausal rheumatoid arthritis, *Ann Rheum Dis* 53:112, 1994.
1655. **Sanchez-Guerro J, Liang MH, Karlson EW, Hunter DJ, Colditz GA**, Postmenopausal estrogen therapy and the risk for developing systemic lupus erythematosus, *Ann Intern Med* 122:430, 1995.
1656. **Arden NK, Lloyd ME, Spector TD, Hughes GRV**, Safety of hormone replacement therapy (HRT) in systemic lupus erythematosus (SLE), *Lupus* 3:11, 1994.
1657. **Formiga F, Moga I, Nolla JM, Pac M, Mitjavila F, Roig-Escofet D**, Loss of bone mineral density in premenopausal women with systemic lupus erythematosus, *Ann Rheum Dis* 54:274, 1995.
1658. **Fernández M, Calvo-Alén J, Bertoli AM, Bastian HM, Fessler BJ, McGwin G Jr, Reveille JD, Vilá LM, Alarcón GS**, Systemic lupus erythematosus in a multiethnic US cohort (LUMINA L II): relationship between vascular events and the use of hormone replacement therapy in postmenopausal women, *J Clin Rheumatol* 13:261, 2007.
1659. **Sowers MF, Hochberg M, Crabbe JP, Muhich A, Crutchfield M, Updike S**, Association of bone mineral density and sex hormone levels with osteoarthritis of the hand and knee in premenopausal women, *Am J Epidemiol* 143:38, 1996.
1660. **Ham KD, Loeser RF, Lindgren BR, Carlson CS**, Effects of long-term estrogen replacement therapy on osteoarthritis severity in cynomolgus monkeys, *Arthritis Rheum* 46:1956, 2002.
1661. **Nevitt MC, Cummings SR, Lane NE, Hochberg MC, Scott JC, Pressman AR, Genant HK, Cauley JA**; for the **Study of Osteoporotic Fractures Research Group**, Association of estrogen replacement therapy with the risk of osteoarthritis of the hip in elderly white women, *Arch Intern Med* 156:2073, 1996.
1662. **Baum M, Budzar AU, Cuzick J, Forbes J, Houghton JH, Klijn JG, Sahmoud T; The ATAC (Arimidex Tamoxifen Alone or in Combination) Trialists' Group**, Anastrozole alone or in combination with tamoxifen versus tamoxifen alone for adjuvant treatment of postmenopausal women with early breast cancer: first results of the ATAC randomised trial, *Lancet* 359:2131, 2002.
1663. **Sowers MR, McConnell D, Jannausch M, Buyuktur AG, Hochberg MC, Jamadar DA**, Estradiol and its metabolites and their association with knee osteoarthritis, *Arthritis Rheum* 54:2481, 2006.
1664. **Volpe A, Lucenti V, Forabosco A, Boselli F, Latessa AM, Pozzo P, Petraglia F, Genazzani AR**, Oral discomfort and hormone replacement therapy in the post-menopause, *Maturitas* 13:1, 1991.
1665. **Norderyd OM, Grossi SG, Machtei EE, Zambon JJ, Hausmann E, Dunford RG, Genco RJ**, Periodontal status of women taking postmenopausal estrogen supplementation, *J Periodontol* 64:957, 1993.
1666. **Grossi SG**, Effect of estrogen supplementation on periodontal disease, *Compend Contin Educ Dent Suppl* 22:S30, 1998.

1667. **Daniell HW**, Postmenopausal tooth loss: contributions to edentulism by osteoporosis and cigarette smoking, *Arch Intern Med* 143:1678, 1983.
1668. **Krall EA, Dawson-Hughes B, Papas A, Garcia RI**, Tooth loss and skeletal bone density in healthy postmenopausal women, *Osteoporos Int* 4:104, 1994.
1669. **Paganini-Hill A**, The benefits of estrogen replacement therapy on oral health. The Leisure World Cohort, *Arch Intern Med* 155:2325, 1995.
1670. **Grodstein F, Colditz GA, Stampfer MJ**, Post-menopausal hormone use and tooth loss: a prospective study, *JAMA* 127:372, 1996.
1671. **Harris TM**, The pharmacological treatment of voice disorders, *Folia Phoniatr* 44:143, 1992.
1672. **Lindholm P, Vilkmann E, Raudaskoski T, Suvanto-Luukkonen E, Kauppila A**, The effect of postmenopause and postmenopausal HRT on measured voice values and vocal symptoms, *Maturitas* 28:47, 1997.
1673. **Schneider B, van Trotsenburg M, Hanke G, Bigenzahn W, Huber J**, Voice impairment and menopause, *Menopause* 11:151, 2004.
1674. **Firat Y, Engin-Ustun Y, Kizilay A, Ustun Y, Akarcary M, Selimoglu E, Kafkasli A**, Effect of intranasal estrogen on voice quality, *J Voice* 23:716, 2009.
1675. **Caruso S, Roccasalva L, Sapienza G, Zappalá M, Nuciforo G, Biondi S**, Laryngeal cytological aspects in women with surgically induced menopause who were treated with transdermal estrogen replacement therapy, *Fertil Steril* 74:1073, 2000.
1676. **Metka M, Enzensberger H, Knogler W, Schurz B, Aichmair H**, Ophthalmic complaints as a climacteric symptom, *Maturitas* 14:3, 1991.
1677. **Altintas O, Caglar Y, Yüksel N, Demirci A, Karabas L**, The effects of menopause and hormone replacement therapy on quality and quantity of tear, intraocular pressure and ocular blood flow, *Ophthalmologica* 218:120, 2004.
1678. **Kramer P, Lubkin V, Potter W, Jacobs M, Labay G, Silverman P**, Cyclic changes in conjunctival smears from menstruating females, *Ophthalmology* 97:303, 1990.
1679. **Moss SE, Klein R, Klein BE**, Prevalence and risk factors for dry eye syndrome, *Arch Ophthalmol* 118:1264, 2000.
1680. **Sator MO, Joura EA, Golaszewski T, Gruber D, Frigo P, Metka M, Hommer A, Huber JC**, Treatment of menopausal keratoconjunctivitis sicca with topical oestradiol, *Br J Obstet Gynaecol* 105:100, 1998.
1681. **Schaumberg DA, Buring JE, Sullivan DA, Dana MR**, Hormone replacement therapy and dry eye syndrome, *JAMA* 286:2114, 2001.
1682. **Uncu G, Avci R, Uncu Y, Kaymaz C, Develioglu O**, The effects of different hormone replacement therapy regimens on tear function, intraocular pressure and lens opacity, *Gynecol Endocrinol* 22:501, 2006.
1683. **Erdem U, Ozdegirmenci O, Sobaci E, Sobaci G, Göktolga U, Dagli S**, Dry eye in post-menopausal women using hormone replacement therapy, *Maturitas* 56:257, 2007.
1684. **Klein BEK, Klein R, Ritter LL**, Is there evidence of an estrogen effect on age-related lens opacities?, *Arch Ophthalmol* 112:85, 1994.
1685. **Benitez del Castillo JM, del Rio T, Garcia-Sanchez J**, Effects of estrogen use on lens transmittance in postmenopausal women, *Ophthalmology* 104:970, 1997.
1686. **Cumming RG, Mitchell P**, Hormone replacement therapy, reproductive factors, and cataracts. The Blue Mountains Eye Study, *Am J Epidemiol* 145:242, 1997.
1687. **Worzala K, Hiller R, Sperduto R, Mutalik K, Murabito JM, Moskowitz M, D'Agostino RB, Wilson PW**, Postmenopausal estrogen use, type of menopause, and lens opacities: the Framingham studies, *Arch Intern Med* 161:1448, 2001.
1688. **Aina FO, Smeeth L, Hubbard R, Hurt LS, Fletcher AE**, Hormone replacement therapy and cataract: a population-based case-control study, *Eye* 20:417, 2006.
1689. **Sator MO, Joura EA, Frigo P, Kurz C, Metka M, Hommer A, Huber JC**, Hormone replacement therapy and intraocular pressure, *Maturitas* 28:55, 1997.
1690. **Sator MO, Akramian J, Joura EA, Nessmann A, Wedrich A, Gruber D, Metka M, Huber JC**,

Reduction of intraocular pressure in a glaucoma patient undergoing hormone replacement therapy, *Maturitas* 29:93, 1998.

1691. **Tint NL, Alexander P, Tint KM, Vasileiadis GT, Yeung AM, Azuara-Blanco A**, Hormone therapy and intraocular pressure in nonglaucomatous eyes, *Menopause* 17:157, 2010.
1692. **Pasqualie LR, Rosner BA, Hankinson SE, Kang JH**, Attributes of female reproductive aging and their relation to primary open-angle glaucoma: a prospective study, *J Glaucoma* 16:598, 2007.
1693. **Eye Disease Case-Control Study Group**, Risk factors for neovascular age-related macular degeneration, *Arch Ophthalmol* 110:1702, 1992.
1694. **Klein R, Klein BEK, Jensen SC, Mares-Perlman JA, Cruickshanks KF, Palta M**, Age-related maculopathy in a multiracial United States population: the National Health and Nutrition Examination Survey III, *Ophthalmology* 106:1056, 1999.
1695. **Snow KK, Cote J, Yang W, Davis NJ, Seddon JM**, Association between reproductive and hormonal factors and age-related maculopathy in postmenopausal women, *Am J Ophthalmol* 134:842, 2002.
1696. **Abramov Y, Borik S, Yahalom C, Fatum M, Avgil G, Brzezinski A, Banin E**, The effect of hormone therapy on the risk for age-related maculopathy in postmenopausal women, *Menopause* 11:62, 2004.
1697. **Seitzman RL, Mangione C, Ensrud KE, Cauley JA, Stone KL, Cummings SR, Hochberg MC, Hillier TA, Yu F, Coleman AL**, Postmenopausal hormone therapy and age-related maculopathy in older women, *Ophthalmic Epidemiol* 15:308, 2008.
1698. **Clark K, Sowers MR, Wallace RB, Jannausch ML, Lemke J, Anderson CV**, Age-related hearing loss and bone mass in a population of rural women aged 60 to 85 years, *Ann Epidemiol* 5:8, 1995.
1699. **Collin RA, Kalay E, Tariq M, Peters T, van der Zwaag B, Venselaar H, Oostrik J, Lee K, Ahmed ZM, Caylan R, Li Y, Spierenburg HA, Eyupoglu E, Heister A, Riazuddin S, Bahat E, Ansar M, Arsian S, Wollnik B, Brunner HG, Cremers CW, Karaguzel A, Ahmad W, Cremers FP, Vriend G, Friedman TB, Riazuddin S, Leal SM, Kremer H**, Mutations of ESRRB encoding estrogen-related receptor beta cause autosomal-recessive nonsyndromic hearing impairment DFNB35, *Am J Hum Genet* 82:125, 2008.
1700. **Simonoska R, Stenberg AE, Duan M, Yakimchuk K, Fridberger A, Sahlin L, Gustafsson J-A, Hultcrantz M**, Inner ear pathology and loss of hearing in estrogen receptor-beta deficient mice, *J Endocrinol* 201:397, 2009.
1701. **Kilicdag EB, Yavuz H, Bagis T, Tarim E, Erkan AN, Kazanci F**, Effects of estrogen therapy on hearing in postmenopausal women, *Am J Obstet Gynecol* 190:77, 2004.
1702. **Guimaraes P, Frisina ST, Mapes F, Tadros SF, Frisina DR, Frisina RD**, Progestin negatively affects hearing in aged women, *Proc Natl Acad Sci U S A* 103:14246, 2006.
1703. **Curhan SG, Eliassen AH, Eavey RD, Wang M, Lin BM, Curhan GC**, Menopause and postmenopausal hormone therapy and risk of hearing loss, *Menopause* 24(9):1049, 2017.
1704. **Ness J, Aronow WS, Beck G**, Menopausal symptoms after cessation of hormone replacement therapy, *Maturitas* 53:356, 2006.
1705. **Lindh-Åstrand L, Brynhildsen J, Hoffman M, Hammar M**, Vasomotor symptoms usually reappear after cessation of postmenopausal hormone therapy: a Swedish population-based study, *Menopause* 16:1213, 2009.
1706. **Haimov-Kochman R, Barak-Glantz E, Arbel R, Leefsma M, Brzezinski A, Milwidsky A, Hochner-Ceinikier D**, Gradual discontinuation of hormone therapy does not prevent the reappearance of climacteric symptoms: a randomized prospective study, *Menopause* 13:370, 2006.
1707. **Asian E, Bagis T, Kilicdag EB, Tarim E, Erkanli S, Kuscu E**, How best to discontinue postmenopausal hormone therapy: immediate or tapered?, *Maturitas* 56:78, 2007.
1708. **Lindh-Åstrand L, Bixo M, Hirschberg AL, Sundström-Poromaa I, Hammar M**, A randomized controlled study of taper-down or abrupt discontinuation of hormone therapy in women treated for vasomotor symptoms, *Menopause* 17:72, 2010.
1709. **Cunha EP, Azevedo LH, Pompei LM, Strufaldi R, Steiner ML, Ferreira JA, Peixoto S, Fernandes CE**, Effect of abrupt discontinuation versus gradual dose reduction of postmenopausal hormone therapy on hot flushes, *Climacteric* 13(4):362, 2010.
1710. **Quigley MET, Martin PL, Burnier AM, Brooks P**, Estrogen therapy arrests bone loss in elderly women,

Am J Obstet Gynecol 156:1516, 1987.

1711. **Cauley JA, Seeley DG, Ensrud K, Ettinger B, Black D, Cummings SR;** for the **Study of Osteoporotic Fractures Research Group**, Estrogen replacement therapy and fractures in older women, *Ann Intern Med* 122:9, 1995.
1712. **Schneider DL, Barrett-Connor EL, Morton DJ**, Timing of postmenopausal estrogen for optimal bone mineral density. The Rancho Bernardo Study, *JAMA* 277:543, 1997.
1713. **Kiel DP, Felson DT, Anderson JJ, Wilson PWF, Moskowitz MA**, Hip fracture and the use of estrogen in postmenopausal women: the Framingham Study, *N Engl J Med* 317:1169, 1987.
1714. **Schubert W, Cullberg G, Edgar B, Hedner T**, Inhibition of 17 $\beta$ -estradiol metabolism by grapefruit juice in ovariectomized women, *Maturitas* 20:155, 1995.
1715. **Weber A, Jagger R, Börner A, Lomger G, Vollanrh R, Matthey K, Balogh A**, Can grapefruit juice influence ethinylestradiol bioavailability?, *Contraception* 63:41, 1996.
1716. **Dorgan JF, Reichman ME, Judd JT, Brown C, Longcope C, Schatzkin A, Campbell WS, Franz C, Kahle L, Taylor PR**, The relation of reported alcohol ingestion to plasma levels of estrogens and androgens in premenopausal women, *Cancer Causes Control* 5:53, 1994.
1717. **Muti P, Trevisan M, Micheli A, Krogh V, Bolelli G, Sciajno R, Schünemann HJ, Berrino F**, Alcohol consumption and total estradiol in premenopausal women, *Cancer Epidemiol Biomark Prev* 7:189, 1998.
1718. **Chen KL, Madak-Erdogan Z**, Estrogen and microbiota crosstalk: should we pay attention? *Trends Endocrinol Metab* 27(11):752, 2016.
1719. National Osteoporosis Foundation, <http://www.nof.org/professionals/>
1720. **Lees B, Molleson T, Arnett TR, Stevenson JC**, Differences in proximal femur bone density over two centuries, *Lancet* 341:673, 1993.
1721. **Eaton SB, Nelson DA**, Calcium in evolutionary perspective, *Am J Clin Nutr* 54:281S, 1991.
1722. **Cooper C, Campion G, Melton LJ III**, Hip fractures in the elderly: a world-wide projection, *Osteoporos Int* 2:285, 1992.
1723. **Riis BJ, Hansen MA, Jensen AM, Overgaard K, Christiansen C**, Low bone mass and fast rate of bone loss at menopause: equal risk factors for future fracture: a 15-year follow-up study, *Bone* 19:9, 1996.
1724. **Theitz G, Buch B, Rizzoli R, Slosman D, Clavien H, Sizonko PC, Bonjour JPH**, Longitudinal monitoring of bone mass accumulation in healthy adolescents: evidence for a marked reduction after 16 years of age at the levels of lumbar spine and femoral neck in female subjects, *J Clin Endocrinol Metab* 75:1060, 1992.
1725. **Matkovic V, Jelic T, Wardlaw GM, Ilich J, Goel PK, Wright JK, Andon MB, Smith KT, Heaney RP**, Timing of peak bone mass in Caucasian females and its implication for the prevention of osteoporosis. Inference from a cross-sectional model, *J Clin Invest* 93:799, 1994.
1726. **Sabatier JP, Guaydier-Souquieres G, Laroche D, Benmalek A, Fournier L, Guillon-Metz F, Delavenne J, Denis AY**, Bone mineral acquisition during adolescence and early adulthood: a study in 574 healthy females 10–24 years of age, *Osteoporos Int* 6:141, 1996.
1727. **Chevalley T, Bonjour JP, Ferrari S, Rizzoli R**, Deleterious effect of late menarche on distal tibia microstructure in healthy 20-year-old and premenopausal middle-aged women, *J Bone Miner Res* 24:144, 2009.
1728. **Csermely T, Halvax L, Vizer M, Drozgyik I, Tamás P, Göcze P, Szabó I, Jeges S, Szilágyi A**, Relationship between adolescent amenorrhea and climacteric osteoporosis, *Maturitas* 56:368, 2007.
1729. **Bonjour JP, Carrie AL, Ferrari S, Clavien H, Slosman D, Theintz G, Rizzoli R**, Calcium-enriched foods and bone mass growth in prepubertal girls: a randomized, double-blind, placebo-controlled trial, *J Clin Invest* 15:1287, 1997.
1730. **Bonjour JP, Chevalley T, Ammann P, Slosman D, Rizzoli R**, Gain in bone mineral mass in prepubertal girls 3.5 years after discontinuation of calcium supplementation: a follow-up study, *Lancet* 358:1208, 2001.
1731. **Stear SJ, Prentice A, Jones SC, Cole TJ**, Effect of a calcium and exercise intervention on the bone mineral status of 16–18-y-old adolescent girls, *Am J Clin Nutr* 77:985, 2003.
1732. **Rozen GS, Rennert G, Dodiuk-Gad RP, Rennert HS, Ish-Shalom N, Diab G, Raz B, Ish-Shalom S**, Calcium supplementation provides an extended window of opportunity for bone mass accretion after menarche, *Am J Clin Nutr* 78:993, 2003.

1733. **Recker RR, Davies KM, Hinders SM, Heaney RP, Stegman MR, Kimmel DB**, Bone gain in young women, *JAMA* 268:2403, 1992.
1734. **Sirola J, Kröger H, Honkanen R, Jurvelin JS, Sandini L, Tuppurainen MT, Saarikoski S**, Factors affecting bone loss around menopause in women without HRT: a prospective study, *Maturitas* 45:159, 2003.
1735. **Ettinger B**, Prevention of osteoporosis: treatment of estradiol deficiency, *Obstet Gynecol* 72:125, 1988.
1736. **Lindsay R**, Prevention and treatment of osteoporosis, *Lancet* 341:801, 1993.
1737. **Manolagas SC**, Birth and death of bone cells: basic regulatory mechanisms and implications for the pathogenesis and treatment of osteoporosis, *Endocr Rev* 21:115, 2000.
1738. **Manolagas SC, Kousteni S, Jilka RL**, Sex steroids and bone, *Recent Prog Horm Res* 57:385, 2002.
1739. **Pacifici R**, Cytokines, estrogen, and postmenopausal osteoporosis—the second decade, *Endocrinology* 130:2659, 1998.
1740. **Canalis E, Giustina A, Bilezikian JP**, Mechanisms of anabolic therapies for osteoporosis, *N Engl J Med* 357:905, 2007.
1741. **Hofbauer LC, Khosla S, Dunstan CR, Lacey DL, Boyle WJ, Riggs BL**, The roles of osteoprotegerin and osteoprotegerin ligand in the paracrine regulation of bone resorption, *J Bone Miner Res* 15:2, 2000.
1742. **Liel Y, Kraus S, Levy J, Shany S**, Evidence that estrogens modulate activity and increase the number of 1,25-dihydroxyvitamin D receptors in osteoblast-like cells (ROS 17/2.8), *Endocrinology* 130:2597, 1992.
1743. **Prince RL**, Counterpoint: estrogen effects on calcitropic hormones and calcium homeostasis, *Endocr Rev* 15:301, 1994.
1744. **Smith EP, Boyd J, Frank GR, Takahashi H, Cohen RM, Specker B, Williams TC, Lubahn DB, Korach KS**, Estrogen resistance caused by a mutation in the estrogen-receptor gene in a man, *N Engl J Med* 331:1056, 1994.
1745. **Carani C, Qin K, Simoni M, Faustini-Fustini M, Serpente S, Boyd J, Korach KS, Simpson ER**, Effect of testosterone and estradiol in a man with aromatase deficiency, *N Engl J Med* 337:91, 1997.
1746. **Khosla S, Melton LJ III, Atkinson EJ, O’Fallon WM, Klee GG, Riggs BL**, Relationship of serum sex steroid levels and bone turnover markers with bone mineral density in men and women: a key role for bioavailable estrogen, *J Clin Endocrinol Metab* 83:2266, 1998.
1747. **Bilezikian JP, Morishima A, Bell J, Grumbach MM**, Increased bone mass as a result of estrogen therapy in a man with aromatase deficiency, *N Engl J Med* 339:599, 1998.
1748. **Rochira V, Faustini-Fustini M, Balestrieri A, Carani C**, Estrogen replacement therapy in a man with congenital aromatase deficiency: effects of different doses of transdermal estradiol on bone mineral density and hormonal parameters, *J Clin Endocrinol Metab* 85:1841, 2000.
1749. **Ettinger B, Sidney S, Cummings SR, Libanati C, Bikle DD, Tekawa IS, Tolan K, Steiger P**, Racial differences in bone density between young adult black and white subjects persist after adjustment for anthropometric, lifestyle, and biochemical differences, *J Clin Endocrinol Metab* 82:429, 1997.
1750. **Nelson DA, Simpson PM, Johnson CC, Barondess DA, Kleerekopper M**, The accumulation of whole body skeletal mass in third- and fourth-grade children: effects of age, ethnicity, and body composition, *Bone* 20:73, 1997.
1751. **Hui SL, Dimeglio LA, Longcope C, Peacock M, McClintock R, Perkins AJ, Johnston CC Jr**, Difference in bone mass between black and white American children: attributable to body build, sex hormone levels, or bone turnover?, *J Clin Endocrinol Metab* 88:642, 2003.
1752. **Bryant RJ, Wastney ME, Martin BR, Wood O, McCabe GP, Morshidi M, Smith DL, Peacock M, Weaver CM**, Racial differences in bone turnover and calcium metabolism in adolescent females, *J Clin Endocrinol Metab* 88:1043, 2003.
1753. **Finkelstein JS, Lee MT, Sowers M, Ettinger B, Neer RM, Kelsey JL, Cauley JA, Huang M, Greendale GA**, Ethnic variation in bone density in premenopausal and early perimenopausal women: effects of anthropometric and lifestyle factors, *J Clin Endocrinol Metab* 87:3057, 2002.
1754. **Finkelstein JS, Brockwell SE, Mehta V, Greendale GA, Sowers MR, Ettinger B, Lo JC, Johnston JM, Cauley JA, Danielson ME, Neer RM**, Bone mineral density changes during the menopause transition in a multiethnic cohort of women, *J Clin Endocrinol Metab* 93:861, 2008.

1755. **Grisso JA, Kelsey JL, Strom BL, O'Brien LA, Maislin G, LaPann K, Samuelson L, Hoffman S;** the **Northeast Hip Fracture Study Group**, Risk factors for hip fracture in black women, *N Engl J Med* 330:1555, 1994.
1756. **Iki M, Kajita E, Dohi Y, Nishino H, Kusaka Y, Tsuchida C, Yamamoto K, Ishii Y,** Age, menopause, bone turnover markers and lumbar bone loss in healthy Japanese women, *Maturitas* 25:59, 1996.
1757. **Seeman E, Hopper JL, Bach LA, Cooper ME, Parkinson E, McKay J, Jerums G,** Reduced bone mass in daughters of women with osteoporosis, *N Engl J Med* 320:554, 1989.
1758. **Slemenda CW, Christian JC, Williams CJ, Norton JA, Johnston CC Jr,** Genetic determinants of bone mass in adult women: a reevaluation of the twin model and the potential importance of gene interaction on heritability estimates, *J Bone Miner Res* 6:561, 1991.
1759. **Morrison NA, Qi JC, Tokita A, Kelly PJ, Crofts L, Nguyen TV, Sambrook PN, Eisman JA,** Prediction of bone density from vitamin D receptor alleles, *Nature* 367:284, 1994.
1760. **Ferrari S, Rizzoli R, Chevalley T, Slosman D, Eisman JA, Bonjour J-P,** Vitamin-D-receptor-gene polymorphisms and change in lumbar-spine bone mineral density, *Lancet* 345:423, 1995.
1761. **Uitterlinden AG, Burger H, Huang Q, Yue F, McGuigan FEA, Grant SFA, Hofman A, van Leeuwen JPTM, Pols HAP, Ralston SH,** Relation of alleles of the collagen type Ia1 gene to bone density and the risk of osteoporotic fractures in postmenopausal women, *N Engl J Med* 338:1016, 1998.
1762. **Richards JB, Rivadeneira F, Inouye M, Pastinen TM, Soranzo N, Wilson SG, Andrew T, Falchi M, Gwilliam R, Ahmadi KR, Valdes AM, Arp P, Whittaker P, Verlaan DJ, Jhamai M, Kumanduri V, Moorhouse M, van Meurs JB, Hofman A, Pols HA, Hart D, Zhai G, Kato BS, Mullin BH, Zhang F, Deloukas P, Uitterlinden AG, Spector TD,** Bone mineral density, osteoporosis, and osteoporotic fractures: a genome-wide association study, *Lancet* 371:1505, 2008.
1763. **Richelson LS, Wahner HW, Melton LJ III, Riggs BL,** Relative contributions of aging and estrogen deficiency to postmenopausal bone loss, *N Engl J Med* 311:1273, 1984.
1764. **Nilas L, Christiansen C,** Bone mass and its relationship to age and the menopause, *J Clin Endocrinol Metab* 65:697, 1987.
1765. **Alvioli LV,** Calcium and osteoporosis, *Ann Rev Nutr* 4:471, 1984.
1766. **Johnston CC Jr, Hui SL, Witt RM, Appledorn R, Baker RS, Longcope C,** Early menopausal changes in bone mass and sex steroids, *J Clin Endocrinol Metab* 61:905, 1985.
1767. **Riggs BL, Wahner HW, Melton LJ III, Richelson LS, Judd HL, Offord KP,** Rates of bone loss in the appendicular and axial skeletons of women, *J Clin Invest* 77:1487, 1986.
1768. **Riggs BL, Wahner HW, Dunn WL, Mazess RB, Offord KP, Melton LJ III,** Differential changes in bone mineral density of the appendicular and axial skeleton with aging: relationship to spinal osteoporosis, *J Clin Invest* 67:328, 1981.
1769. **Baran D, Sorensen A, Grimes J, Lew R, Karellas A, Johnson B, Roche J,** Dietary modification with dairy products for preventing vertebral bone loss in premenopausal women: a three-year prospective study, *J Clin Endocrinol Metab* 70:264, 1990.
1770. **Elders PJM, Lips P, Netelenbos C, Van Ginkel FC, Khoe E, Van Der Vijgh WJF, Van Der Stelt PF,** Long-term effect of calcium supplementation on bone loss in perimenopausal women, *J Bone Miner Res* 9:963, 1994.
1771. **Gambacciani M, Spinetti A, Taponeco F, Cappagli B, Maffei S, Manetti P, Piaggese L, Fioretti P,** Bone loss in perimenopausal women: a longitudinal study, *Maturitas* 18:191, 1994.
1772. **Garton M, Martin J, New S, Lee S, Loveridge N, Milne J, Reid D, Reid I, Robins S,** Bone mass and metabolism in women aged 45–55, *Clin Endocrinol* 44:536, 1996.
1773. **Guthrie JR, Ebeling PR, Hopper JL, Barrett-Connor E, Dennerstein L, Dudley EC, Burger HG, Wark JD,** A prospective study of bone loss in menopausal Australian-born women, *Osteoporos Int* 8:282, 1998.
1774. **Sowers M, Crutchfield M, Bandekar R, Randolph JF, Shapiro B, Schork MA, Jannausch M,** Bone mineral density and its change in pre- and perimenopausal white women: the Michigan Bone Health Study, *J Bone Miner Res* 13:1134, 1998.

1775. **Waller K, Reim J, Fenster L, Swan SH, Brumback B, Windham GC, Lasley B, Ettinger B, Marcus R**, Bone mass and subtle abnormalities in ovulatory function in healthy women, *J Clin Endocrinol Metab* 81:663, 1996.
1776. **De Souza MJ, Miller BE, Sequenzia LC, Luciano AA, Ulreich S, Stier S, Prestwood K, Lasley BL**, Bone health is not affected by luteal phase abnormalities and decreased ovarian progesterone production in female runners, *J Clin Endocrinol Metab* 82:2867, 1997.
1777. **NIH Consensus Development Panel on Osteoporosis Prevention, Diagnosis and Therapy**, Osteoporosis prevention, diagnosis and therapy, *JAMA* 285:785, 2001.
1778. **Cummings SR, Melton LJ III**, Epidemiology and outcomes of osteoporotic fractures, *Lancet* 359:1761, 2002.
1779. **Jacobs RM, Himes JH, Pihlstrom BL**, Associations of periodontal disease with femoral bone mineral density and estrogen replacement therapy: cross-sectional evaluation of US adults from NHANES III, *J Clin Periodontol* 27:778, 2000.
1780. **Paganini-Hill A**, Estrogen replacement therapy—something to smile about, *Compend Contin Educ Dent Suppl* 22:S4, 1998.
1781. **Krall EA, Dawson-Hughes B, Hannan MT, Wilson PW, Kiel DP**, Postmenopausal estrogen replacement and tooth retention, *Am J Med* 102:536, 1997.
1782. **Grodstein F, Colditz GA, Stampfer MJ**, Tooth loss and hormone use in postmenopausal women, *Compend Contin Educ Dent Suppl* 22:S9, 1998.
1783. **Lindsay R, Silverman SL, Cooper C, Hanley DA, Barton I, Broy SB, Licata A, Benhamou L, Geusens P, Flowers K, Stracke H, Seeman E**, Risk of new vertebral fracture in the year following a fracture, *JAMA* 285:320, 2001.
1784. **Black DM, Arden NK, Palermo L, Pearson J, Cummings SR**, Prevalent vertebral deformities predict hip fractures and new vertebral deformities but not wrist fractures. Study of Osteoporotic Fractures Research Group, *J Bone Miner Res* 14:821, 1999.
1785. **Melton LJ III, Atkinson EJ, Cooper C, O’Fallon WM, Riggs BL**, Vertebral fractures predict subsequent fractures, *Osteoporos Int* 10:214, 1999.
1786. **Blieue D, Nguyen ND, Milch VE, Nguyen TV, Eisman JA, Center JR**, Mortality risk associated with low-trauma osteoporotic fracture and subsequent fracture in men and women, *JAMA* 301:513, 2009.
1787. **Silverman SL, Shen W, Minshall ME, Xie S, Moses KH**, Prevalence of depressive symptoms in postmenopausal women with low bone mineral density and/or prevalent vertebral fracture: results from the Multiple Outcomes of Raloxifene Evaluation (MORE) study, *J Rheumatol* 34:140, 2007.
1788. **Whooley MA, Kip KE, Cauley JA, Ensrud KE, Nevitt MC, Browner WS**, Depression, falls, and risk of fracture in older women. Study of Osteoporotic Fractures Research Group, *Arch Intern Med* 159:484, 1999.
1789. **Robbins J, Hirsch C, Whitmer R, Cauley J, Harris T**, The association of bone mineral density and depression in an older population, *J Am Geriatr Soc* 49:732, 2001.
1790. **Milliken LA, Wilhelmy J, Martin CJ, Finkenthal N, Cuysler E, Metcalfe L, Guido TA, Going SB, Lohman TG**, Depressive symptoms and changes in body weight exert independent and site-specific effects on bone in postmenopausal women exercising for 1 year, *J Gerontol A Biol Sci Med Sci* 61:488, 2006.
1791. **Kahl KG, Greggersen W, Rudolf S, Stoeckelhuber BM, Bergmann-Koester CU, Dibbelt L, Schweiger U**, Bone mineral density, bone turnover, and osteoprotegerin in depressed women with and without borderline personality disorder, *Psychosom Med* 68:669, 2006.
1792. **Yirmiya R, Goshen I, Bajayo A, Kreisel T, Feldman S, Tam J, Trembovler V, Csernus V, Shohami E, Bab I**, Depression induces bone loss through stimulation of the sympathetic nervous system, *Proc Natl Acad Sci U S A* 103:16876, 2006.
1793. **Richards JB, Papaioannou A, Adachi JD, Joseph L, Whitson HE, Prior JC, Goltzman D; for the Canadian Multicentre Osteoporosis Study (CaMos) Research Group**, Effect of selective serotonin reuptake inhibitors on the risk of fracture, *Arch Intern Med* 167:188, 2007.
1794. **Warden SJ, Robling AG, Sanders MS, Blizotes MM, Turner CH**, Inhibition of the serotonin (5-hydroxytryptamine) transporter reduces bone accrual during growth, *Endocrinology* 146:685, 2005.

1795. **Haney EM, Chan BK, Diem SJ, Ensrud KE, Cauley JA, Barrett-Connor E, Orwoll E, Bliziotes MM;** for the **Osteoporotic Fractures in Men Study Group**, Association of low bone mineral density with selective serotonin reuptake inhibitor use by older men, *Arch Intern Med* 167:1246, 2007.
1796. **Diem SJ, Blackwell TL, Stone KL, Yaffe K, Haney EM, Bliziotes MM, Ensrud KE,** Use of antidepressants and rates of hip bone loss in older women: the Study of Osteoporotic Fractures, *Arch Intern Med* 167:1240, 2007.
1797. **Johnston CC Jr, Slemenda CW, Melton LJ III,** Clinical use of bone densitometry, *N Engl J Med* 324:1105, 1991.
1798. **Cummings SR, Black DM, Nevitt MC, Browner W, Cauley J, Ensrud K, Genant KH, Palermo L, Scott J, Vogt TM,** Bone density at various sites for prediction of hip fractures, *Lancet* 341:72, 1993.
1799. **Johnston CC Jr, Slemenda CW,** Identification of patients with low bone mass by single photon absorptiometry and single-energy X-ray absorptiometry, *Am J Med* 98(Suppl 2A):37S, 1995.
1800. **Rubin SM, Cummings SR,** Results of bone densitometry affect women's decisions about taking measures to prevent fractures, *Ann Intern Med* 116:990, 1992.
1801. **Silverman SL, Greenwald M, Klein RA, Drinkwater BL,** Effect of bone density information on decisions about hormone replacement therapy: a randomized trial, *Obstet Gynecol* 89:321, 1997.
1802. **Miller PD, Bonnicksen SL, Rosen CJ,** Consensus of an international panel on the clinical utility of bone mass measurements in the detection of low bone mass in the adult population, *Calcif Tissue Int* 58:207, 1996.
1803. **Gregg EW, Kriska AM, Salamone LM, Roberts MM, Anderson SJ, Ferrell RE, Kuller LH, Cauley JA,** The epidemiology of quantitative ultrasound: a review of the relationships with bone mass, osteoporosis and fracture risk, *Osteoporos Int* 7:89, 1997.
1804. **Hans D, Dargent-Molina P, Schott AM, Sebert JL, Cormier C, Kotzik PO, Delmas PD, Pouilles JM, Breart G, Meunier PJ;** for the **EPIDOS Prospective Study Group**, Ultrasonographic heel measurements to predict hip fracture in elderly women: the EPIDOS prospective study, *Lancet* 348:511, 1996.
1805. **Njeh CF, Boivin CM, Langton CM,** The role of ultrasound in the assessment of osteoporosis: a review, *Osteoporos Int* 7:7, 1997.
1806. **Faber J, Gallow AM,** Changes in bone mass during prolonged subclinical hyperthyroidism due to L-thyroxine treatment: a meta-analysis, *Eur J Endocrinol* 130:350, 1994.
1807. **Cummings SR, Nevitt MC, Browner WS, Stone K, Fox KM, Ensrud KE, Cauley J, Black D, Vogt TM,** Risk factors for hip fracture in white women. Study of Osteoporotic Fractures Research Group, *N Engl J Med* 332:767, 1995.
1808. **Bauer DC, Nevitt MC, Ettinger B, Stone K,** Low thyrotropin levels are not associated with bone loss in older women: a prospective study, *J Clin Endocrinol Metab* 82:2931, 1997.
1809. **Yang R, Yao L, Fang Y, Sun J, Guo T, Yang K, Tian L,** The relationship between subclinical thyroid dysfunction and the risk of fracture or low bone mineral density: a systematic review and meta-analysis of cohort studies, *J Bone Miner Metab* 36(2):209, 2018. doi: 10.1007/s00774-017-0828-5.
1810. **Siris ES, Miller PD, Barrett-Connor E, Faulkner KG, Wehren LE, Abbott TA, Berger ML, Santora AC, Sherwood LM,** Identification and fracture outcomes of undiagnosed low bone mineral density in postmenopausal women: results from the National Osteoporosis Risk Assessment, *JAMA* 286:2815, 2001.
1811. **National Osteoporosis Foundation,** The FRAX Tool, [http://www.nof.org/frax\\_update.htm](http://www.nof.org/frax_update.htm), 2009.
1812. **WHO Collaborating Centre for Metabolic Bone Diseases, University of Sheffield, UK,** FRAX, WHO fracture risk assessment tool, <http://www.shef.ac.uk/FRAX/>, 2009.
1813. **Tosteson AN, Melton LJ III, Dawson-Hughes B, Baim S, Favus MJ, Khosia S, Lindsay RL;** **National Osteoporosis Foundation Guide Committee,** Cost-effective osteoporosis treatment thresholds: the United States perspective, *Osteoporos Int* 19:437, 2008.
1814. **Dawson-Hughes B, Tosteson AN, Melton LJ III, Baim S, Favus MJ, Khosia S, Lindsay R,** Implications of absolute fracture risk assessment for osteoporosis practice guidelines in the USA, *Osteoporos Int* 19:449, 2008.
1815. **Garnero P, Gineyts E, Rious JP, Delmas PD,** Assessment of bone resorption with a new marker of collagen degradation in patients with metabolic bone disease, *J Clin Endocrinol Metab* 79:780, 1994.



1816. **Prestwood KM, Pilbeam CC, Burleson JA, Woodiel FN, Delmas PD, Deftos LJ, Raisz LG**, The short term effects of conjugated estrogen on bone turnover in older women, *J Clin Endocrinol Metab* 79:366, 1994.
1817. **Chesnut CH III, Bell NH, Clark GS, Drinkwater BL, English SC, Johnston CC Jr, Notelovitz M, Rosen M, Cain DF, Flessland KA, Mallinak NJS**, Hormone replacement therapy in postmenopausal women: urinary N-telopeptide of type I collagen monitors therapeutic effect and predicts response of bone mineral density, *Am J Med* 102:29, 1997.
1818. **Komulainen MH, Kröger H, Tuppurainen MT, Heikkinen A-M, Alhava E, Honkanen R, Saarikoski S**, HRT and Vit D in prevention of non-vertebral fractures in postmenopausal women; a 5 year randomized trial, *Maturitas* 31:45, 1998.
1819. **Mosekilde L, Beck-Nielsen H, Sørensen OH, Nielsen SP, Charles P, Vestergaard P, Hermann AP, Gram J, Hansen TB, Abrahamsen B, Ebbesen EN, Stilgren L, Jensen LB, Brot C, Hansen B, Tofteng CL, Eiken P, Kolthoff N**, Hormonal replacement therapy reduces forearm fracture incidence in recent postmenopausal women—results of the Danish Osteoporosis Prevention Study, *Maturitas* 36:181, 2000.
1820. **Cauley J, Robbins J, Chen Z, Cummings SR, Jackson RD, LaCroix AZ, LeBoff M, Lewis CE, McGowan J, Neuner J, Pettinger M, Stefanick ML, Wactawski-Wende J, Watts NB; for the Women's Health Initiative Investigators**, Effects of estrogen plus progestin on risk of fracture and bone mineral density. The Women's Health Initiative Randomized Trial, *JAMA* 290:1729, 2003.
1821. **Islam S, Liu Q, Chines AA, Helzner E**, Trend in incidence of osteoporosis-related fractures among 40- to 69-year-old women: analysis of a large insurance claims database, 2000–2005, *Menopause* 16:77, 2009.
1822. **Weiss NC, Ure CL, Ballard JH, Williams AR, Daling JR**, Decreased risk of fractures of the hip and lower forearm with postmenopausal use of estrogen, *N Engl J Med* 303:1195, 1980.
1823. **Ettinger B, Genant HK, Cann CE**, Long-term estrogen replacement therapy prevents bone loss and fractures, *Ann Intern Med* 102:319, 1985.
1824. **Felson DT, Zhang Y, Hannan MT, Kiel DP, Wilson PWF, Anderson JJ**, The effect of postmenopausal estrogen therapy on bone density in elderly women, *N Engl J Med* 329:1141, 1993.
1825. **Lindsay R, MacLean A, Kraszewski A, Clark AC, Garwood J**, Bone response to termination of estrogen treatment, *Lancet* 1:1325, 1978.
1826. **Horsman A, Nordin BEC, Crilly RG**, Effect on bone of withdrawal of estrogen therapy, *Lancet* 2:33, 1979.
1827. **Christiansen C, Christiansen MS, Transbol IB**, Bone mass in postmenopausal women after withdrawal of oestrogen/gestagen replacement therapy, *Lancet* 1:459, 1981.
1828. **Trémollières FA, Pouilles JM, Ribot C**, Withdrawal of hormone replacement therapy is associated with significant vertebral bone loss in postmenopausal women, *Osteoporos Int* 12:385, 2001.
1829. **Sornay-Rendu E, Garnero P, Munoz F, Duboeuf F, Delmas PD**, Effect of withdrawal of hormone replacement therapy on bone mass and bone turnover: the OFELY study, *Bone* 33:159, 2003.
1830. **Greendale GA, Espeland M, Slone S, Marcus R, Barrett-Connor E; PEPI Safety Follow-up Study (PSFS) Investigators**, Bone mass response to discontinuation of long-term hormone replacement therapy: results from the Postmenopausal Estrogen/Progestin Interventions (PEPI) Safety Follow-up Study, *Arch Intern Med* 25:665, 2002.
1831. **Gallagher JC, Rapuri PB, Haynatzki G, Detter JR**, Effect of discontinuation of estrogen, calcitriol, and the combination of both on bone density and bone markers, *J Clin Endocrinol Metab* 87:4914, 2002.
1832. **Bagger YZ, Tankó LB, Alexandersen P, Hansen HB, Møllgaard A, Ravn P, Qvist P, Kanis JA, Christiansen C**, Two to three years of hormone replacement treatment in healthy women have long-term preventive effects on bone mass and osteoporotic fractures: the PERF study, *Bone* 34:728, 2004.
1833. **Middleton ET, Steel SA**, The effects of short-term hormone replacement therapy on long-term bone mineral density, *Climacteric* 10:257, 2007.
1834. **Barrett-Conner E, Wehren LE, Siris ES, Miller P, Chen YT, Abbott TA III, Berger ML, Santora AC, Sherwood LM**, Recency and duration of postmenopausal hormone therapy: effects on bone mineral density and fracture risk in the National Osteoporosis Risk Assessment (NORA) study, *Menopause* 10:412, 2003.
1835. **Stevenson JC, Cust MP, Gangar KF, Hillard TC, Lees B, Whitehead MI**, Effects of transdermal versus oral hormone replacement therapy on bone density in spine and proximal femur in postmenopausal women,

Lancet 336:1327, 1990.

1836. **Eiken P, Kolthoff N, Nielsen SP**, Effect of 10 years' hormone replacement therapy on bone mineral content in postmenopausal women, *Bone* 19:191S, 1996.
1837. **Nelson HD, Rizzo J, Harris E, Cauley J, Ensrud K, Bauer DC, Orwoll E; Study of Osteoporotic Fractures Research Group**, Osteoporosis and fractures in postmenopausal women using estrogens, *Arch Intern Med* 162:2278, 2002.
1838. **Naessén T, Persson I, Thor L, Mallmin H, Ljunghall S, Bergstrom R**, Maintained bone density at advanced ages after long-term treatment with low-dose estradiol implants, *Br J Obstet Gynaecol* 100:454, 1993.
1839. **Armamento-Villareal R, Civitelli R**, Estrogen action on the bone mass of postmenopausal women is dependent on body mass and initial bone density, *J Clin Endocrinol Metab* 80:776, 1995.
1840. **Villareal DT, Binder EF, Williams DB, Schechtman KB, Yarasheski KE, Kohrt WM**, Bone mineral density response to estrogen replacement in frail elderly women. A randomized controlled trial, *JAMA* 286:815, 2001.
1841. **Cauley JA, Zmuda JM, Ensrud KE, Bauer DC, Ettinger B; for the Study of Osteoporotic Fractures Research Group**, Timing of estrogen replacement therapy for optimal osteoporosis prevention, *J Clin Endocrinol Metab* 86:5700, 2001.
1842. **Lindsay R, Hart DM, Clark DM**, The minimum effective dose of estrogen for postmenopausal bone loss, *Obstet Gynecol* 63:759, 1984.
1843. **O'Connell MB**, Pharmacokinetic and pharmacologic variation between different estrogen products, *J Clin Pharmacol* 35(Suppl 9):18S, 1995.
1844. **Reginster JY, Sarlet N, Deroisy R, Albert A, Gaspard U, Franchimont P**, Minimal levels of serum estradiol prevent postmenopausal bone loss, *Calcif Tissue Int* 51:340, 1992.
1845. **Ettinger B, Pressman A, Sklarin P, Bauer DC, Cauley JA, Cummings SR**, Associations between low levels of serum estradiol, bone density, and fractures among elderly women: the study of osteoporotic fractures, *J Clin Endocrinol Metab* 83:2239, 1998.
1846. **Cummings SR, Browner WS, Bauer D, Stone K, Ensrud K, Jamal S, Ettinger B; for the Study of Osteoporotic Fractures Research Group**, Endogenous hormones and the risk of hip and vertebral fractures among older women, *N Engl J Med* 339:733, 1998.
1847. **Ettinger B, Genant HK, Cann CE**, Postmenopausal bone loss is prevented by treatment with low-dosage estrogen with calcium, *Ann Intern Med* 106:40, 1987.
1848. **Ettinger B, Genant HK, Steiger P, Madvig P**, Low-dosage micronized 17 $\beta$ -estradiol prevents bone loss in postmenopausal women, *Am J Obstet Gynecol* 166:479, 1992.
1849. **Genant HK, Lucas J, Weiss S, Akin M, Emeky R, McNaney-Flint H, Downs R, Mortola J, Watts N, Yank HM, Banav N, Brennan JJ, Nolan JC; for the Estratab/Osteoporosis Study Group**, Low-dose esterified estrogen therapy: effects on bone, plasma estradiol concentrations, endometrium, and lipid levels, *Arch Intern Med* 157:2609, 1997.
1850. **Gass M, Liu J, Rebar RW**, The effect of low-dose conjugated equine estrogens and cyclic MPA on bone density, *Maturitas* 26:143, 2002.
1851. **Mizunuma H, Okano H, Soda M, Kagami I, Miyamoto S, Tokizawa T, Honjo S, Ibuki Y**, Prevention of postmenopausal bone loss with minimal uterine bleeding using low dose continuous estrogen/progestin therapy: a 2-year prospective study, *Maturitas* 27:69, 1997.
1852. **Prior JC, Vigna YM, Barr SI, Rexworthy C, Lentle BC**, Cyclic medroxyprogesterone treatment increases bone density: a controlled trial in active women with menstrual cycle disturbances, *Am J Med* 96:521, 1994.
1853. **Selby PL, Peacock M, Barkworth SA, Brown WB, Taylor GA**, Early effects of ethinyl oestradiol and norethisterone treatment in postmenopausal women on bone resorption and calcium regulating hormones, *Clin Sci* 69:265, 1985.
1854. **Christiansen C, Nilas L, Riis BJ, Rodbro P, Deftos L**, Uncoupling of bone formation and resorption by combined oestrogen and progestagen therapy in postmenopausal osteoporosis, *Lancet* 2:800, 1985.
1855. **Munk-Jensen N, Nielsen SP, Obel EB, Eriksen PB**, Reversal of postmenopausal vertebral bone loss by

- oestrogen and progestogen: a double blind placebo controlled study, *Br Med J* 296:1150, 1988.
1856. **Gallagher JC, Kable WT, Goldgar D**, Effect of progestin therapy on cortical and trabecular bone: comparison with estrogen, *Am J Med* 90:171, 1991.
1857. **Grey A, Cundy T, Evans M, Reid I**, Medroxyprogesterone acetate enhances the spinal bone mineral density response to oestrogen in late post-menopausal women, *Clin Endocrinol* 44:293, 1996.
1858. **Adachi JD, Sargeant EJ, Sagle MA, Lamont D, Fawcett PD, Bensen WG, McQueen M, Nazir DJ, Goldsmith CH**, A double-blind randomised controlled trial of the effects of medroxyprogesterone acetate on bone density of women taking oestrogen replacement therapy, *Br J Obstet Gynaecol* 104:64, 1997.
1859. **Fuleihan GE, Brown EM, Curtis K, Berger MJ, Berger BM, Gleason R, LeBoff MS**, Effect of sequential and daily continuous hormone replacement therapy on indexes of mineral metabolism, *Arch Intern Med* 152:1904, 1992.
1860. **Nielsen SP, Bärenholdt O, Hermansen F, Munkin-Jensen NB**, Magnitude and pattern of skeletal response to long term continuous and cyclic sequential oestrogen/progestin treatment, *Br J Obstet Gynaecol* 101:319, 1994.
1861. **Heaney RP, Draper MW**, Raloxifene and estrogen: comparative bone-remodeling kinetics, *J Clin Endocrinol Metab* 82:3425, 1997.
1862. **Neele SJ, Evertz R, De Valk-De Roo GW, Roos JC, Netelenbos JC**, Effect of 1 year of discontinuation of raloxifene or estrogen therapy on bone mineral density after 5 years of treatment in healthy postmenopausal women, *Bone* 30:599, 2002.
1863. **Meunier PJ, Vignot E, Garnero P, Confavreux E, Paris E, Liu-Leage S, Sarkar S, Liu T, Wong M, Draper MW**, Treatment of postmenopausal women with osteoporosis or low bone density with raloxifene. Raloxifene Study Group, *Osteoporos Int* 10:330, 1999.
1864. **Bjarnason NH, Sarkar S, Duong T, Mitlak B, Delmas PD, Christiansen C**, Six and twelve month changes in bone turnover are related to reduction in vertebral fracture risk during 3 years of raloxifene treatment in postmenopausal osteoporosis, *Osteoporos Int* 12:922, 2001.
1865. **Sambrook PN, Geusens P, Ribot C, Solimano JA, Ferrer-Barriendos J, Gaines K, Verbruggen N, Melton ME**, Alendronate produces greater effects than raloxifene on bone density and bone turnover in postmenopausal women with low bone density: results of EFFECT (Efficacy of FOSAMAX® versus EVISTA® Comparison Trial) International, *J Intern Med* 255:503, 2004.
1866. **Reid IR, Ames RW, Evans MC, Gamble GD, Sharpe SJ**, Long-term effects of calcium supplementation on bone loss and fractures in postmenopausal women: a randomized controlled trial, *Am J Med* 98:331, 1995.
1867. **Recker RR, Hinders S, Davies KM, Heaney RP, Stegman MR, Lappe JM, Kimmel DB**, Correcting calcium nutritional deficiency prevents spine fractures in elderly women, *J Bone Miner Res* 11:1961, 1996.
1868. **Dawson-Hughes B, Harris SS, Krall EA, Dallal GE**, Effect of calcium and vitamin D supplementation on bone density in men and women 65 years of age or older, *N Engl J Med* 337:670, 1997.
1869. **Baeksgaard L, Andersen KP, Hyldstrup L**, Calcium and vitamin D supplementation increases spinal BMD in healthy postmenopausal women, *Osteoporos Int* 8:255, 1998.
1870. **NIH Consensus Development Panel on Optimal Calcium Intake**, Optimal calcium intake, *JAMA* 272:1942, 1994.
1871. **Tang BM, Eslick GD, Nowson C, Smith C, Bensoussan A**, Use of calcium or calcium in combination with vitamin D supplementation to prevent fractures and bone loss in people aged 50 years and older: a meta-analysis, *Lancet* 370:657, 2007.
1872. **Hasling C, Charles P, Jensen FT, Mosekilde L**, Calcium metabolism in postmenopausal osteoporosis: the influence of dietary calcium and net absorbed calcium, *J Bone Miner Res* 5:939, 1990.
1873. **Heaney RP, Recker RR**, Distribution of calcium absorption in middle-aged women, *Am J Clin Nutr* 43:299, 1986.
1874. **Wallace RB, Wactawski-Wende J, O'Sullivan MJ, Larson JC, Cochrane B, Gass M, Masaki K**, Urinary tract stone occurrence in the Women's Health Initiative (WHI) randomized clinical trial of calcium and vitamin D supplements, *Am J Clin Nutr* 94(1):270, 2011.
1875. **Gallagher JC, Smith LM, Yalamanchili V**, Incidence of hypercalciuria and hypercalcemia during vitamin D

and calcium supplementation in older women, *Menopause* 21(11):1173, 2014.

1876. **Prince RL, Smith M, Dick IM, Price RI, Webb PG, Henderson NK, Harris MM**, Prevention of postmenopausal osteoporosis: a comparative study of exercise, calcium supplementation, and hormone-replacement therapy, *N Engl J Med* 325:1189, 1991.
1877. **Heikinheimo RJ, Inkovaara JA, Harju EJ, Haavisto MV, Kaarela RH, Kataja JM, Kokko AM, Kolho LA, Rajala S**, Annual injection of vitamin D and fractures of aged bones, *Calcif Tissue Int* 51:105, 1992.
1878. **Aloia JF, Vaswani A, Yeh JK, Ross PL, Flaster E, Dilmanian FA**, Calcium supplementation with and without hormone replacement therapy to prevent postmenopausal bone loss, *Ann Intern Med* 120:97, 1994.
1879. **Rizzoli R, Biver E, Bonjour JP, Coxam V, Goltzman D, Kanis JA, Lappe J, Rejnmark L, Sahni S, Weaver C, Weiler H, Reginster JY**, Benefits and safety of dietary protein for bone health-an expert consensus paper endorsed by the European Society for Clinical and Economical Aspects of Osteoporosis, Osteoarthritis, and Musculoskeletal Diseases and by the International Osteoporosis Foundation, *Osteoporos Int*, 2018. doi: 10.1007/s00198-018-4534-5 [Epub ahead of print].
1880. **Lloyd T, Andon MB, Rollings N, Martel JK, Landis JR, Demers LM, Egli DF, Kiesselhorst K, Kulin HE**, Calcium supplementation and bone mineral density in adolescent girls, *JAMA* 270:841, 1993.
1881. **Cadogan J, Eastell R, Jones N, Barker ME**, Milk intake and bone mineral acquisition in adolescent girls: randomised, controlled intervention trial, *Br Med J* 315:1255, 1997.
1882. **Ross AC, Manson JE, Abrams SA, Aloia JF, Brannon PM, Clinton SK, Durazo-Arvizu RA, Gallagher JC, Gallo RL, Jones G, Kovacs CS, Mayne ST, Rosen CJ, Shapses SA**, The 2011 report on dietary reference intakes for calcium and vitamin D from the Institute of Medicine: what clinicians need to know, *J Clin Endocrinol Metab* 96(1):53, 2011.
1883. **Ross EA, Szabo NJ, Tebbett IR**, Lead content of calcium supplements, *JAMA* 284:1425, 2000.
1884. **Curhan GC, Willett WC, Speizer FE, Spiegelman D, Stampfer MJ**, Comparison of dietary calcium with supplemental calcium and other nutrients as factors affecting the risk for kidney stones in women, *Ann Intern Med* 126:497, 1997.
1885. **Lips P**, Vitamin D deficiency and secondary hyperparathyroidism in the elderly: consequences for bone loss and fractures and therapeutic implications, *Endocr Rev* 22:477, 2001.
1886. **Holick MF**, Vitamin D deficiency, *N Engl J Med* 357:266, 2007.
1887. **Armas LA, Hollis BW, Heaney RP**, Vitamin D2 is much less effective than vitamin D3 in humans, *J Clin Endocrinol Metab* 89:5387, 2004.
1888. **Boonen S, Lips P, Bouillon R, Bischoff-Ferrari HA, Vanderschueren D, Haentjens P**, Need for additional calcium to reduce the risk of hip fracture with vitamin D supplementation: evidence from a comparative meta analysis of randomized controlled trials, *J Clin Endocrinol Metab* 92:1415, 2007.
1889. **The DIPART (vitamin D individual Patient Analysis of Randomized Trials) Group**, Patient level pooled analysis of 68,500 patients from seven major vitamin D fracture trials in US and Europe, *Br Med J* 340:b5463, 2010. doi: 10.1136/bmj.b5463.
1890. **Rosen CJ, Morrison A, Zhou H, Storm D, Hunter SJ, Musgrave K, Chen T, Wen W, Holick MF**, Elderly women in northern New England exhibit seasonal changes in bone mineral density and calciotropic hormones, *Bone Miner* 25:83, 1994.
1891. **González G, Alvarado JN, Rojas A, Navarrete C, Velásquez CG, Arteaga E**, High prevalence of vitamin D deficiency in Chilean healthy postmenopausal women with normal sun exposure: additional evidence for a worldwide concern, *Menopause* 14:455, 2007.
1892. **Ginde AA, Liu MC, Camargo CA Jr**, Demographic differences and trends of vitamin D insufficiency in the US population, 1988–2004, *Arch Intern Med* 169:626, 2009.
1893. **Thomas MK, Lloyd-Jones DM, Thadhani RI, Shaw AC, Deraska DJ, Kitch BT, Vamvakas EC, Dick IM, Prince RL, Finkelstein JS**, Hypovitaminosis D in medical inpatients, *N Engl J Med* 338:777, 1998.
1894. **Feskanich D, Singh V, Willett WC, Colditz GA**, Vitamin A intake and hip fractures among postmenopausal women, *JAMA* 287:47, 2002.
1895. **Whiting SJ, Lemke B**, Excess retinol intake may explain the high incidence of osteoporosis in northern

Europe, *Nutr Rev* 57:191, 1999.

1896. **Jackson RD, LaCroix AZ, Gass M, Wallace RB, Robbins J, Lewis CE, Bassford T, Beresford SAA, Black HR, Blanchette P, Bonds DE, Brunner RL, Brzyski RG, Caan B, Cauley JA, Chlebowski RT, Cummings SR, Granek I, Hays J, Heiss G, Hendrix SL, Howard BV, Hsia J, Hubbell FA, Johnson KC, Judd H, Kotchen JM, Kuller LH, Langer RD, Lasser NL, Limacher MC, Ludlam S, Manson JE, Margolis KL, McGowan J, Ockene JK, O'Sullivan MJ, Phillips L, Prentice RL, Sarto GE, Stefanick ML, Van Horn L, Wactawski-Wende J, Whitlock E, Anderson GL, Assaf AR, Barad D;** for the **Women's Health Initiative Investigators**, Calcium plus vitamin D supplementation and the risk of fractures, *N Engl J Med* 354:669, 2006.
1897. **Chlebowski RT, Johnson KC, Kooperberg CL, Pettinger M, Wactawski-Wende J, Rohan T, Rossouw J, Lane D, O'Sullivan MJ, Yasmeen S, Hiatt RA, Shikany JM, Vitolins M, Khandekar J, Hubbell FA;** for the **Women's Health Initiative Investigators**, Calcium plus vitamin D supplementation and the risk of breast cancer, *J Natl Cancer Inst* 100:1581, 2008.
1898. **Brunner RL, Cochrane B, Jackson RD, Larson J, Lewis C, Limacher M, Rosal M, Shumaker S, Wallace R;** **Women's Health Initiative Investigators**, Calcium, vitamin D supplementation, and physical function in the Women's Health Initiative, *J Am Diet Assoc* 108:1472, 2008.
1899. **de Boer IH, Tinker LF, Connelly S, Curb JD, Howard BV, Kestenbaum M, Larson JC, Manson JE, Margolis KL, Siscovick DS, Weiss NS;** **Women's Health Initiative Investigators**, Calcium plus vitamin D supplementation and the risk of incident diabetes in the Women's Health Initiative, *Diabetes Care* 31:701, 2008.
1900. **Hsia J, Heiss G, Ren H, Allison M, Dolan NC, Greenland P, Heckbert SR, Johnson KC, Manson JE, Sidney S, Trevisan M;** **Women's Health Initiative Investigators**, Calcium/vitamin D supplementation and cardiovascular events, *Circulation* 115:846, 2007.
1901. **Margolis KL, Ray RM, Van Horn L, Manson JE, Allison MA, Black HR, Beresford SA, Connelly SA, Curb JD, Grimm RH Jr, Kotchen TA, Kuller LH, Wassertheil-Smoller S, Thomson CA, Torner JC;** **Women's Health Initiative Investigators**, Effect of calcium and vitamin D supplementation on blood pressure: the Women's Health Initiative Randomized Trial, *Hypertension* 52:847, 2008.
1902. **LaCroix AZ, Kotchen J, Anderson G, Brzyski R, Cauley JA, Cummings SR, Gass M, Johnson KC, Ko M, Larson J, Manson JE, Stefanick ML, Wactawski-Wende J,** Calcium plus vitamin D supplementation and mortality in postmenopausal women: the Women's Health Initiative calcium-vitamin D randomized controlled trial, *J Gerontol A Biol Sci Med Sci* 64(5):559, 2009. doi: 10.1093/gerona/glp006.
1903. **Melamed ML, Michos ED, Post W, Astor B,** 25-Hydroxyvitamin D levels and the risk of mortality in the general population, *Arch Intern Med* 168:1629, 2008.
1904. **Melamed ML, Muntner P, Michos ED, Uribarri J, Weber C, Sharma J, Raggi P,** Serum 25-hydroxyvitamin D levels and the prevalence of peripheral arterial disease: results from NHANES 2001 to 2004, *Arterioscler Thromb Vasc Biol* 28:1179, 2008.
1905. **Pilz S, Dobnig H, Nijpels G, Heine RJ, Stehouwer CD, Snijder MB, van Dam RM, Dekker JM,** Vitamin D and mortality in older men and women, *Clin Endocrinol (Oxf)* 71(5):666, 2009.
1906. **Garland CF, Gorham ED, Mohr SB, Grant WB, Giovannucci EL, Lipkin M, Newmark HL, Holick MF, Garland FC,** Vitamin D and prevention of breast cancer: pooled analysis, *J Steroid Biochem Mol Biol* 103:708, 2007.
1907. **Ginde AA, Scragg R, Schwartz RS, Camargo CA Jr,** Prospective study of serum 25-hydroxyvitamin d level, cardiovascular disease mortality, and all-cause mortality in older U. S. adults, *J Am Geriatr Soc* 57:1595, 2009.
1908. **Cauley JA, Wampler NS, Barnhart JM, Wu L, Allison M, Chen Z, Hendrix S, Robbins J, Jackson RD;** **Women's Health Initiative Investigators**, Incidence of fractures compared to cardiovascular disease and breast cancer: the Women's Health Initiative Observational Study, *Osteoporos Int* 19:1717, 2008.
1909. **Holick MF,** High prevalence of vitamin D inadequacy and implications for health, *Mayo Clin Proc* 81:353, 2006.
1910. **Cauley JA, LaCroix AZ, Wu L, Horwitz M, Danielson ME, Bauer DC, Lee JS, Jackson RD, Robbins**

- JA, Wu C, Stanczyk FZ, LeBoff MS, Wactawski-Wende J, Sarto G, Ockene J, Cummings SR**, Serum 25-hydroxyvitamin D concentrations and risk for hip fractures, *Ann Intern Med* 149:242, 2008.
1911. **Tilyard MW, Spears GFS, Thomson J, Dovey S**, Treatment of postmenopausal osteoporosis with calcitriol or calcium, *N Engl J Med* 326:357, 1992.
1912. **Chapuy MC, Meunier PJ**, Prevention of secondary hyperparathyroidism and hip fracture in elderly women with calcium and vitamin D3 supplements, *Osteoporos Int* 6(Suppl 3):60, 1996.
1913. **Bischoff-Ferrari HA, Dawson-Hughes B, Willett W, Staehlin H, Bazemore M, Zee R, Wong J**, Fall prevention by vitamin D treatment: a meta-analysis of randomized controlled trials, *JAMA* 291:1999, 2004.
1914. **Bischoff-Ferrari HA, Dietrich T, Orav EJ, Zhang Y, Karlson EW, Dawson-Hughes B**, Higher 25-hydroxyvitamin D levels are associated with better lower extremity function in both active and inactive adults 60+ years of age, *Am J Clin Nutr* 80:752, 2004.
1915. **Dawson-Hughes B, Heaney RP, Holick MF, Lips P, Meunier PJ, Vieth R**, Estimates of optimal vitamin D status, *Osteoporos Int* 16:713, 2005.
1916. **de Groen PC, Lubbe DF, Hirsch LJ, Daifotis A, Stephenson W, Freedholm D, Pryor-Tillotson S, Seleznick MJ, Pinkas H, Wang KK**, Esophagitis associated with the use of alendronate, *N Engl J Med* 335:1016, 1996.
1917. **Bauer DC, Black D, Ensrud K, Thompson D, Hochberg M, Nevitt M, Musliner T, Freedholm D**, Upper gastrointestinal tract safety profile of alendronate: the Fracture Intervention Trial, *Arch Intern Med* 28:517, 2000.
1918. **Lowe CE, Depew WT, Vanner SJ, Paterson WG, Meddings JB**, Upper gastrointestinal toxicity of alendronate, *Am J Gastroenterol* 95:634, 2000.
1919. **Mortensen L, Charles P, Bekker PJ, Digennaro J, Johnston CC Jr**, Risedronate increases bone mass in an early postmenopausal population: two years of treatment plus one year of follow-up, *J Clin Endocrinol Metab* 83:396, 1998.
1920. **Harris ST, Watts NB, Genant HK, McKeever CD, Hangartner T, Keller M, Chesnut CH III, Brown J, Eriksen EF, Hoseney MS, Axelrod DW, Miller PD**, Effects of risedronate treatment on vertebral and nonvertebral fractures in women with postmenopausal osteoporosis: a randomized, controlled trial. Vertebral Efficacy With Risedronate Therapy (VERT) Study Group, *JAMA* 282:1344, 1999.
1921. **McClung MR, Geusens P, Miller PD, Zippel H, Bensen WG, Roux C, Adami S, Fogelman I, Diamond T, Eastell R, Meunier PJ, Reginster J-Y; for the Hip Intervention Program Study Group**, Effect of risedronate on the risk of hip fracture in elderly women, *N Engl J Med* 344:333, 2001.
1922. **Foidart JM, Wuttke W, Bouw GM, Gerlinger C, Heithecker R**, A comparative investigation of contraceptive reliability, cycle control and tolerance of two monophasic oral contraceptives containing either drospirenone or desogestrel, *Eur J Contracept Reprod Health Care* 5:124, 2000.
1923. **Fogelman I, Ribot C, Smith R, Ethgen D, Sod E, Reginster J; for the BMD-MN Study Group**, Risedronate reverses bone loss in postmenopausal women with low bone mass: results from a multinational, double-blind, placebo-controlled trial, *J Clin Endocrinol Metab* 85:1895, 2000.
1924. **Grey A, Bolland MJ, Wattie D, Horne A, Gamble G, Reid IR**, The antiresorptive effects of a single dose of zoledronate persist for two years: a randomized, placebo-controlled trial in osteopenic postmenopausal women, *J Clin Endocrinol Metab* 94:538, 2009.
1925. **McClung MR, Miller P, Recknor C, Mesenbrink P, Bucci-Rechtweg C, Benhamou C-L**, Zoledronic acid for the prevention of bone loss in postmenopausal women with low bone mass. A randomized controlled trial, *Obstet Gynecol* 114:999, 2009.
1926. **Schnitzer T, Bone HG, Crepaldi G, Adami S, McClung M, Kiel D, Felsenberg D, Recker RR, Tonino RP, Roux C, Pinchera A, Foldes AJ, Greenspan SL, Levine MA, Emkey R, Santora AC II, Kaur A, Thompson DE, Yates J, Orloff JJ**, Therapeutic equivalence of alendronate 70 mg once-weekly and alendronate 10 mg daily in the treatment of osteoporosis. Alendronate Once-Weekly Study Group, *Aging* 12:1, 2000.
1927. **Brown JP, Kendler DL, McClung MR, Emkey RD, Adachi JD, Bolognese MA, Li Z, Balske A, Lindsey R**, The efficacy and tolerability of risedronate once a week for the treatment of postmenopausal

osteoporosis, *Calcif Tissue Int* 71:103, 2002.

1928. **Luckey MM, Gilchrist N, Bone HG, Davie MW, de Villiers TJ, Wu M, Saifotis AG, Santora AC, Orloff JJ**, Therapeutic equivalence of alendronate 35 milligrams once weekly and 5 milligrams daily in the prevention of postmenopausal osteoporosis, *Obstet Gynecol* 101:711, 2003.
1929. **Blumel JE, Castelo-Branco C, de la Cuadra G, Maciver L, Moreno M, Haya J**, Alendronate daily, weekly in conventional tablets and weekly in enteric tablets: preliminary study on the effects in bone turnover markers and incidence of side effects, *J Obstet Gynaecol* 23:278, 2003.
1930. **Rizzoli R, Greenspan SL, Bone G II, Schnitzer TJ, Watts NB, Adami S, Foldes AJ, Roux C, Levine MA, Uebelhart B, Santora AC II, Kaur A, Peverly CA, Orloff JJ; Alendronate Once-Weekly Study Group**, Two-year results of once-weekly administration of alendronate 70 mg for the treatment of postmenopausal osteoporosis, *J Bone Miner Res* 17:1988, 2002.
1931. **Black DM, Cummings SR, Karpf DB, Cauley JA, Thompson DE, Nevitt MC, Bauer DC, Genant HK, Haskell WL, Marcus R, Ott SM, Torner JC, Quandt SA, Reiss TF, Ensrud KE; for the Fracture Intervention Trial Research Group**, Randomised trial of effect of alendronate on risk of fracture in women with existing vertebral fractures, *Lancet* 348:1535, 1996.
1932. **Karpf DB, Shapiro DR, Seeman E, Ensrud KE, Johnston CC Jr, Adami S, Harris ST, Santora AC II, Hirsch LJ, Oppenheimer L, Thompson D; for the Alendronate Osteoporosis Treatment Study Groups**, Prevention of nonvertebral fractures by alendronate, *JAMA* 277:1159, 1997.
1933. **Black DM, Thompson DE, Bauer DC, Ensrud K, Musliner T, Hochberg MC, Nevitt MC, Suryawanshi S, Cummings SR; for the FIT Research Group**, Fracture risk reduction with alendronate in women with osteoporosis: the Fracture Intervention Trial, *J Clin Endocrinol Metab* 85:4118, 2000.
1934. **Hosking D, Chilvers CED, Christiansen C, Ravn P, Wasnich R, Ross P, McClung M, Balske A, Thompson D, Daley M, Yates AJ; for the Early Postmenopausal Intervention Cohort Study Group**, Prevention of bone loss with alendronate in postmenopausal women under 60 years of age, *N Engl J Med* 338:485, 1998.
1935. **McClung M, Clemmesen B, Daifotis A, Gilchrist NL, Eisman J, Weinstein RS, Fuleihan GEH, Reda C, Yates AJ, Ravn P; for the Alendronate Osteoporosis Prevention Study Group**, Alendronate prevents postmenopausal bone loss in women without osteoporosis: a double-blind, randomized, controlled trial, *Ann Intern Med* 128:253, 1998.
1936. **Cummings SR, Black DM, Thompson DE, Applegate WB, Barrett-Connor E, Musliner TA, Palermo L, Prineas R, Rubin SM, Scott JC, Vogt T, Wallace R, Yates AJ, LaCroix AZ; for the Fracture Intervention Trial Research Group**, Effect of alendronate on risk of fracture in women with low bone density but without vertebral fractures. Results from the Fracture Intervention Trial, *JAMA* 280:2077, 1998.
1937. **Reginster J, Minne HW, Sorensen OH, Hooper M, Roux C, Brandi ML, Lund B, Ethgen D, Pack S, Roumagnac I, Eastell R**, Randomized trial of the effects of risedronate on vertebral fractures in women with established postmenopausal osteoporosis. Vertebral Efficacy with Risedronate Therapy (VERT) Study Group, *Osteoporos Int* 11:83, 2000.
1938. **Sorensen OH, Crawford GM, Mulder H, Hosking DJ, Gennari C, Mellstrom D, Pack S, Wenderoth D, Cooper C, Reginster JY**, Long-term efficacy of risedronate: a 5-year placebo-controlled clinical experience, *Bone* 32:120, 2003.
1939. **Chesnut CH III, Skag A, Christiansen C, Recker R, Stakkestad JA, Hoiseth A, Felsenberg D, Huss H, Gilbride J, Schimmer RC, Delmas P; Oral Ibandronate Osteoporosis Vertebral Fracture Trial in North America and Europe (BONE)**, Effects of oral ibandronate administered daily or intermittently on fracture risk in postmenopausal osteoporosis, *J Bone Miner Res* 19:1241, 2004.
1940. **Black DM, Delmas PD, Estell R, Reid IR, Boonen S, Cauley JA, Cosman F, Lakatos P, Leung PC, Man Z, Mautalen C, Mesenbrink P, Hu H, Caminis J, Tong K, Rosario-Jansen T, Krasnow J, Hue TF, Sellmeyer D, Eriksen EF, Cummings SR; HORIZON Pivotal Fracture Trial**, Once-yearly zoledronic acid for treatment of postmenopausal osteoporosis, *N Engl J Med* 356:1809, 2007.
1941. **Lindsay R, Cosman F, Lobo RA, Walsh BW, Harris ST, Reagan JE, Liss CL, Melton ME, Byrnes**

- CA, Addition of alendronate to ongoing hormone replacement therapy in the treatment of osteoporosis: a randomized, controlled clinical trial, *J Clin Endocrinol Metab* 84:3076, 1999.
1942. **Greenspan S, Bankhurst A, Bell N, Bolognese M, Bone H, Davidson M, Downs R, Emkey R, McKeever C, Miller S, Mulloy A, Weiss S, Heyden N, Lombardi A, Suryawanshi S**, Effects of alendronate and estrogen, alone or in combination, on bone mass and turnover in postmenopausal osteoporosis (abstract), *Bone* 23(Suppl 5):S174, 1998.
1943. **Harris ST, Eriksen EF, Davidson M, Ettinger MP, Moffett AH Jr, Baylink DJ, Crusan CE, Chines AA**, Effect of combined risedronate and hormone replacement therapies on bone mineral density in postmenopausal women, *J Clin Endocrinol Metab* 86:1890, 2001.
1944. **Ettinger B, Pressman A, Schein J**, Clinic visits and hospital admissions for care of acid-related upper gastrointestinal disorders in women using alendronate for osteoporosis, *Am J Manag Care* 4:1377, 1998.
1945. **Faulkner DL, Lucy LM, Heath H, Minshall ME, Muchmore DB**, A claims data assessment of patient compliance with alendronate (abstract), *Osteoporos Int* 8(Suppl 3):21, 1998.
1946. **Siris ES, Harris ST, Rosen CJ, Barr CE, Arvesen JN, Abbott TA, Silverman S**, Adherence to bisphosphonate therapy and fracture rates in osteoporotic women: relationship to vertebral and nonvertebral fractures from 2 US claims databases, *Mayo Clin Proc* 81:1013, 2006.
1947. **MacLennan AH, Wilson DH, Taylor AW**, Hormone replacement therapy use over a decade in an Australian population, *Climacteric* 5:351, 2002.
1948. **Steel SA, Albertazzi P, Howarth EM, Purdie DW**, Factors affecting long-term adherence to hormone replacement therapy after screening for osteoporosis, *Climacteric* 6:96, 2003.
1949. **Bone HG, Hosking D, Devogelaer JP, Tucci JR, Emkey RD, Tonino RP, Rodriguez-Portales JA, Downs RW, Gupta JK, Santora AC, Liberman UA; for the Alendronate Phase III Osteoporosis Treatment Study Group**, Ten years' experience with alendronate for osteoporosis in postmenopausal women, *N Engl J Med* 350:1189, 2004.
1950. **Fleisch H**, Bisphosphonates: mechanisms of action and clinical use in osteoporosis: an update, *Horm Metab Res* 29:145, 1997.
1951. **Greenspan SL, Emkey RD, Bone HG, Weiss SR, Bell NH, Downs RW, McKeever C, Miller SS, Davidson M, Bolognese MA, Mulloy AL, Heyden N, Wu M, Kaur A, Lombardi A**, Significant differential effects of alendronate, estrogen, or combination therapy on the rate of bone loss after discontinuation of treatment of postmenopausal osteoporosis. A randomized, double-blind, placebo-controlled trial, *Ann Intern Med* 137:875, 2002.
1952. **Tonino RP, Meunier PJ, Emkey R, Rodriguez-Portales JA, Menkes CJ, Wasnich RD, Bone HG, Santora AC, Wu M, Desai R, Ross PD, Skeletal benefits of alendronate: 7-year treatment of postmenopausal osteoporotic women. Phase III Osteoporosis Treatment Study Group**, *J Clin Endocrinol Metab* 85:3109, 2000.
1953. **Bagger YZ, Tanko LB, Alexandersen P, Ravn P, Christiansen C**, Alendronate has a residual effect on bone mass in postmenopausal Danish women up to 7 years after treatment withdrawal, *Bone* 33:301, 2003.
1954. **Black DM, Schwartz AV, Ensrud KE, Cauley JA, Levis S, Quandt SA, Satterfield S, Wallace RB, Bauer DC, Palermo L, Wehren LE, Lombardi A, Santora AC, Cummings SR; for the FLEX Research Group**, Effects of continuing or stopping alendronate after 5 years of treatment. The Fracture Intervention Trial Long-term Extension (FLEX): a randomized trial, *JAMA* 296:2927, 2006.
1955. **Curtis JR, Westfall AO, Cheng H, Deizell E, Saag KG**, Risk of hip fracture after bisphosphonate discontinuation: implications for a drug holiday, *Osteoporos Int* 19:1613, 2008.
1956. **Neviaser AS, Lane JM, Lenart BA, Edobor-Osula F, Lorich DG**, Low-energy femoral shaft fractures associated with alendronate use, *J Orthop Trauma* 22:346, 2008.
1957. **Khan AA, Morrison A, Hanley DA, Felsenberg D, McCauley LK, O'Ryan F, Reid IR, Ruggiero SL, Taguchi A, Tetradis S, Watts NB, Brandi ML, Peters E, Guise T, Eastell R, Cheung AM, Morin SN, Masri B, Cooper C, Morgan SL, Obermayer-Pietsch B, Langdahl BL, Al Dabagh R, Davison KS, Kendler DL, Sándor GK, Josse RG, Bhandari M, El Rabbany M, Pierroz DD, Sulimani R, Saunders DP, Brown JP, Compston J; International Task Force on Osteonecrosis of the Jaw**, Diagnosis and



management of osteonecrosis of the jaw: a systematic review and international consensus, *J Bone Miner Res* 30(1):3, 2015. doi: 10.1002/jbmr.2405.

1958. **Wilkinson GS, Kuo Y-F, Freeman JL, Goodwin JS**, Intravenous bisphosphonate therapy and inflammatory conditions or surgery of the jaw: a population-based analysis, *J Natl Cancer Inst* 99:1016, 2007.
1959. **Zervas K, Verrou E, Teleioudis E, Vahsevanos K, Banti A, Mihou D, Krikelis D, Terpos E**, Incidence, risk factors and management of osteonecrosis of the jaw in patients with multiple myeloma: a single-centre experience in 303 patients, *Br J Haematol* 134:620, 2006.
1960. **Durie BGM, Katz M, Crowley J**, Osteonecrosis of the jaw and bisphosphonates, *N Engl J Med* 353:99, 2006.
1961. **Farrugia MC, Summerlin D-J, Krowiak E, Huntley T, Freeman S, Borrowdale R, Tomich C**, Osteonecrosis of the mandible or maxilla associated with the use of new generation bisphosphonates, *Laryngoscope* 116:115, 2006.
1962. **Ruggiero SL, Mebrotra B, Rosenberg TJ, Engroff SL**, Osteonecrosis of the jaws associated with the use of bisphosphonates: a review of 63 cases, *J Oral Maxillofac Surg* 62:527, 2004.
1963. **Di Fede O, Panzarella V, Mauceri R, Fusco V, Bedogni A, Lo Muzio L; SIPMO ONJ Board; Campisi G**, The dental management of patients at risk of medication-related osteonecrosis of the jaw: new paradigm of primary prevention, *Biomed Res Int* 2018:2684924, 2018.
1964. **Sharma A, Einstein AJ, Vallakati A, Arbab-Zadeh A, Walker MD, Mukherjee D, Homel P, Borer JS, Lichstein E**, Risk of atrial fibrillation with use of oral and intravenous bisphosphonates, *Am J Cardiol* 113:1815, 2014.
1965. **Heckbert SR, Li G, Cummings SR, Smith NL, Psaty BM**, Use of alendronate and risk of incident atrial fibrillation in women, *Arch Intern Med* 168:826, 2008.
1966. **Sørensen HT, Christensen S, Mehnert F, Pedersen L, Chapuriat RD, Cummings SR, Baron JA**, Use of bisphosphonates among women and risk of atrial fibrillation and flutter: a population based case-control study, *Br Med J* 336:813, 2008.
1967. **Abrahamsen B, Eiken P, Brixen K**, Atrial fibrillation in fracture patients treated with oral bisphosphonates, *J Intern Med* 265:581, 2009.
1968. **Bunch TJ, Anderson JL, May HT, Muhlestein JB, Horne BD, Crandall BG, Weiss JP, Lappé DL, Osborn JS, Day JD**, Relation of bisphosphonate therapies and risk of developing atrial fibrillation, *Am J Cardiol* 103:824, 2009.
1969. **Huang W-F, Usai Y-W, Wen Y-W, Hsiao F-Y, Kuo KN, Tsai C-R**, Osteoporosis treatment and atrial fibrillation: alendronate versus raloxifene, *Menopause* 17:57, 2010.
1970. **Wysowski D**, Reports of esophageal cancer with oral bisphosphonate use, *N Engl J Med* 360:89, 2009.
1971. **Solomon DH, Patrick A, Brookhart MA**, More on reports of esophageal cancer with oral bisphosphonate use, *N Engl J Med* 360:1790, 2009.
1972. **Abrahamsen B, Eiken P, Eastell R**, More on reports of esophageal cancer with oral bisphosphonate use, *N Engl J Med* 360:1789, 2009.
1973. **Wright E, Schofield PT, Molokhia M**, Bisphosphonates and evidence for association with esophageal and gastric cancer: a systematic review and meta-analysis, *Br Med J Open* 5(12):e007133, 2015.
1974. **Miller PD, Bolognese MA, Lewiecki EM, McClung MR, Ding B, Austin M, Liu Y, San Martin J; for the AMG 162 Bone Loss Study Group**, Effect of denosumab on bone density and turnover in postmenopausal women with low bone mass after long-term continued, discontinued, and restarting of therapy: a randomized blinded phase 2 clinical trial, *Bone* 43:222, 2008.
1975. **Bone HG, Bolognese MA, Yuen CK, Kendler DL, Wang H, Liu Y, San Martin J**, Effects of denosumab on bone mineral density and bone turnover in postmenopausal women, *J Clin Endocrinol Metab* 93:2149, 2008.
1976. **Cummings SR, San Martin J, McClung MR, Siris ES, Eastell R, Reid IR, Delmas PD, Zoog HB, Austin M, Wang A, Kutilek S, Adami S, Zanchetta J, Libanati C, Siddhanti S, Christiansen C; for the FREEDOM Trial**, Denosumab for prevention of fractures in postmenopausal women with osteoporosis, *N Engl J Med* 361:756, 2009.
1977. **Brown JP, Prince RL, Deal C, Recker RR, Kiel DP, de Gregorio LH, Hadji P, Hofbauer LC, Alvaro-**

- Gracia JM, Wang H, Austin M, Wagman RB, Newmark R, Libanati C, San Martin J, Bone HG**, Comparison of the effect of denosumab and alendronate on BMD and biochemical markers of bone turnover in postmenopausal women with low bone mass: a randomized, blinded phase 3 trial, *J Bone Miner Res* 24:153, 2009.
1978. **Bone HG, Wagman RB, Brandi ML, Brown JP, Chapurlat R, Cummings SR, Czerwiński E, Fahrleitner-Pammer A, Kendler DL, Lippuner K, Reginster JY, Roux C, Malouf J, Bradley MN, Daizadeh NS, Wang A, Dakin P, Pannacciulli N, Dempster DW, Papapoulos S**, 10 years of denosumab treatment in postmenopausal women with osteoporosis: results from the phase 3 randomised FREEDOM trial and open-label extension, *Lancet Diabetes Endocrinol* 5(7):513, 2017.
1979. **Amgen Manufacturing Limited**, Prolia (denosumab) injection, for subcutaneous use: US prescribing information 2017. [http://pi.amgen.com/united\\_states/prolia/prolia\\_pi.pdf](http://pi.amgen.com/united_states/prolia/prolia_pi.pdf)
1980. **Chesnut CH III, Silverman S, Andriano K, Genant H, Gimona A, Harris S, Kiel D, LeBoff M, Maricic M, Miller P, Moniz C, Peacock M, Richardson P, Watts N, Baylink D**, A randomized trial of nasal spray salmon calcitonin in postmenopausal women with established osteoporosis: the prevent recurrence of osteoporotic fractures study. PROOF Study Group, *Am J Med* 109:267, 2000.
1981. **Ito A, Yoshimura M**, Mechanisms of the analgesic effect of calcitonin on chronic pain by alteration of receptor or channel expression, *Mol Pain* 13:174, 2017.
1982. **Pak CY, Sakhae K, Adams-Huet B, Piziak V, Peterson RD, Poindexter JR**, Treatment of postmenopausal osteoporosis with slow-release sodium fluoride: final update of a randomized controlled trial, *Ann Intern Med* 123:401, 1995.
1983. **Pak CYC, Sakhae K, Rubin C, Rao S**, Update of fluoride in the treatment of osteoporosis, *Endocrinologist* 8:15, 1998.
1984. **Meunier PJ, Roux C, Ortolani S, Diaz-Curiel M, Compston J, Marquis P, Cormier C, Isaia G, Badurski J, Wark JD, Collette, J, Reginster JY**, Effects of long-term strontium ranelate treatment on vertebral fracture risk in postmenopausal women with osteoporosis, *Osteoporos Int* 20:1663, 2009.
1985. **Reginster JY, Felsenberg D, Boonen S, Diez-Perez A, Rizzoli R, Brandi ML, Spector TD, Brixen K, Goemaere S, Cormier C, Balogh A, Delmas PD, Meunier PJ**, Effects of long-term strontium ranelate treatment on the risk of nonvertebral and vertebral fractures in postmenopausal osteoporosis: results of a five-year, randomized, placebo-controlled trial, *Arthritis Rheum* 58:1687, 2009.
1986. **Deeks ED, Dhillon S**, Strontium ranelate: a review of its use in the treatment of postmenopausal osteoporosis, *Drugs* 70(6):733, 2010.
1987. **Berning B, Kuijk CV, Kuper JW, Bennink HJ, Kicovic PM, Fauser BC**, Effects of two doses of tibolone on trabecular and cortical bone loss in early postmenopausal women: a two-year randomized placebo-controlled study, *Bone* 19:395, 1996.
1988. **Lippuner K, Haenggi W, Birkhaeuser MH, Casez J-P, Jaeger P**, Prevention of postmenopausal bone loss using tibolone or conventional peroral or transdermal hormone replacement therapy with 17 $\beta$ -estradiol and dihydrogesterone, *J Bone Miner Res* 12:806, 1997.
1989. **Studd J, Arnala I, Kicovic PM, Zamblera D, Kröger H, Holland N**, A randomized study of tibolone on bone mineral density in osteoporotic postmenopausal women with previous fractures, *Obstet Gynecol* 92:574, 1998.
1990. **Milner M, Harrison RF, Gilligan E, Kelly A**, Bone density changes during two years' treatment with tibolone or conjugated estrogens and norgestrel, compared with untreated controls in postmenopausal women, *Menopause* 7:327, 2000.
1991. **Rymer J**, Effects of 8 years of treatment with tibolone 2.5 mg daily on postmenopausal bone loss, *Osteoporos Int* 12:478, 2001.
1992. **Ederveen AGH, Kloosterboer HJ**, Tibolone exerts an estrogenic effect on bone leading to prevention of bone loss and reduction in bone resorption in ovariectomized rats, *Osteoporos Int* 8:95, 1999.
1993. **Palomba S, Morelli M, Di Carlo C, Noia R, Pellicano M, Zullo F**, Bone metabolism in postmenopausal women who were treated with a gonadotropin-releasing hormone agonist and tibolone, *Fertil Steril* 78:63, 2002.
1994. **Cosman F, Nieves J, Woelfert L, Formica C, Gordon S, Shen V, Lindsay R**, Parathyroid hormone added

to established hormone therapy: effects on vertebral fracture and maintenance of bone mass after parathyroid hormone withdrawal, *J Bone Miner Res* 16:925, 2001.

1995. **Body JJ, Gaich GA, Scheele WH, Kulkarni PM, Miller PD, Peretz A, Dore RK, Correa-Rotter R, Papaioanou A, Cumming DC, Hodsmann AB**, A randomized double-blind trial to compare the efficacy of teriparatide (recombinant human parathyroid hormone, 1–34) with alendronate in postmenopausal women with osteoporosis, *J Clin Endocrinol Metab* 87:4528, 2002.
1996. **Rittmaster RS, Bolognese MA, Ettinger MP, Hanley DA, Hodsmann AB, Kendler DL, Rosen CG**, Enhancement of bone mass in osteoporotic women with parathyroid hormone followed by alendronate, *J Clin Endocrinol Metab* 85:2129, 2000.
1997. **Eastell R, Nickelsen T, Marin F, Barker C, Hadji P, Farrerons J, Audran M, Boonen S, Brixen K, Melo Gomes J, Obermayer-Pietsch B, Avramidis A, Sigurdsson G, Glüer CC**, Sequential treatment of severe postmenopausal osteoporosis following teriparatide: final results of the randomized, controlled European Study of Forsteo (EUROFORS), *J Bone Miner Res* 24:726, 2009.
1998. **Díez-Pérez A, Marin F, Eriksen EF, Kendler DL, Krege JH, Delgado-Rodríguez M**, Effects of teriparatide on hip and upper limb fractures in patients with osteoporosis: a systematic review and meta-analysis, *Bone* 120:1, 2018.
1999. **Cosman F**, Anabolic and antiresorptive therapy for osteoporosis: combination and sequential approaches, *Curr Osteoporos Rep* 12(4):385, 2014.
2000. **Niimi R, Kono T, Nishihara A, Hasegawa M, Kono T, Sudo A**, Efficacy of switching from teriparatide to bisphosphonate or denosumab: a prospective, randomized, open-label trial, *JBMR Plus* 2(5):289, 2018.
2001. **Arjmandi BH, Birnbaum R, Goyal NV, Getlinger MJ, Juma S, Alekel L, Hasler CM, Drum ML, Hollis BW, Kukreja SC**, Bone-sparing effect of soy protein in ovarian hormone-deficient rats is related to its isoflavone content, *Am J Clin Nutr* 68(Suppl):1364S, 1998.
2002. **Lees CJ, Ginn TA**, Soy protein isolate diet does not prevent increased cortical bone turnover in ovariectomized macaques, *Calcif Tissue Int* 62:557, 1998.
2003. **Register TC, Jayo MJ, Anthony MS**, Soy phytoestrogens do not prevent bone loss in postmenopausal monkeys, *J Clin Endocrinol Metab* 88:4362, 2003.
2004. **Alekel DL, Peterson C, St. Germain A, Hanson K**, Isoflavone-rich soy isolate exerts significant bone-sparing in the lumbar spine of perimenopausal women (abstract), *Am Soc Bone Miner Res, Annual Meeting*, 1999.
2005. **Gallagher JC, Satpathy R, Rafferty K, Haynatzka V**, The effect of soy protein on bone metabolism, *Menopause* 11:290, 2004.
2006. **Vupadhyayula PM, Gallagher JC, Templin T, Logsdon SM, Smith LM**, Effects of soy protein isolate on bone mineral density and physical performance indices in postmenopausal women—a 2-year randomized, double-blind, placebo-controlled trial, *Menopause* 16:320, 2009.
2007. **Lucas EA, Wild RD, Hammond LJ, Khalil DA, Juma S, Daggy BP, Stoecker BJ, Arjmandi BH**, Flaxseed improves lipid profile without altering biomarkers of bone metabolism in postmenopausal women, *J Clin Endocrinol Metab* 87:1527, 2002.
2008. **Nakamura T, Turner CH, Yoshikawa T, Slemenda CW, Peacock M, Burr DB, Mizuno Y, Orimo H, Ouchi Y, Johnston CC Jr**, Do variations in hip geometry explain differences in hip fracture risk between Japanese and white Americans?, *J Bone Miner Res* 9:1071, 1994.
2009. **Melis GB, Paoletti AM, Cagnacci A**, Ipriflavone prevents bone loss in postmenopausal women, *Menopause* 3:27, 1996.
2010. **Gennari C, Agnusdei D, Crepaldi G, Isaia G, Mazzuoli G, Ortolani S, Bufalino L, Passeri M**, Effect of ipriflavone—a synthetic derivative of natural isoflavones—on bone mass loss in the early years after menopause, *Menopause* 5:9, 1998.
2011. **de Aloysio D, Gambacciani M, Altieri P, Ciaponi M, Ventura V, Mura M, Genazzani AR, Bottiglioni F**, Bone density changes in postmenopausal women with the administration of ipriflavone alone or in association with low-dose ERT, *Gynecol Endocrinol* 11:289, 1997.
2012. **Gambacciani M, Ciaponi M, Cappagli B, Piaggese L, Genazzani AR**, Effects of combined low dose of the

isoflavone derivative ipriflavone and estrogen replacement on bone mineral density and metabolism in postmenopausal women, *Maturitas* 28:75, 1997.

2013. **Alexandersen P, Toussaint A, Christiansen C, Devogelaer J-P, Roux C, Fechtenbaum J, Gennari C, Reginster JY**; for the **Ipriflavone Multicenter European Fracture Study**, Ipriflavone in the treatment of postmenopausal osteoporosis. A randomized controlled trial, *JAMA* 285:1482, 2001.
2014. **Morito K, Hirose T, Kinjo J, Hirakawa T, Okawa M, Nohara T, Ogawa S, Inoue S, Muramatsu M, Masamune Y**, Interaction of phytoestrogens with estrogen receptors a and b, *Biol Pharm Bull* 24:351, 2001.
2015. **Wu J, Oka J, Ezaki J, Ohtomo T, Ueno T, Uchiyama S, Toda T, Uehara M, Ishimi Y**, Possible role of equol status in the effects of isoflavone on bone and fat mass in postmenopausal Japanese women: a double-blind, randomized, controlled trial, *Menopause* 14:866, 2007.
2016. **Meier CR, Schlienger RG, Kraenzlin ME, Schlegel B, Jick H**, HMG-CoA reductase inhibitors and the risk of fractures, *JAMA* 283:3205, 2000.
2017. **Wang PS, Solomon DH, Mogun H, Avorn J**, HMG-CoA reductase inhibitors and the risk of hip fractures in elderly patients, *JAMA* 283:3211, 2000.
2018. **Reid IR, Hague W, Emberson J, Baker J, Tonkin A, Hunt D, MacMahon S, Sharpe N**, Effect of pravastatin on frequency of fracture in the LIPID study: secondary analysis of a randomised controlled trial. Long-term Intervention with Pravastatin in Ischaemic Disease, *Lancet* 357:1887, 2001.
2019. **Ray WA, Daugherty JR, Griffin MR**, Lipid-lowering agents and the risk of hip fracture in a Medicaid population, *Inj Prev* 8:276, 2002.
2020. **LaCroix AZ, Cauley JA, Pettinger M, Hsia J, Bauer DC, McGowan J, Chen Z, Lewis CE, McNeeley SG, Passaro MD, Jackson RD**, Statin use, clinical fracture, and bone density in postmenopausal women: results from the Women's Health Initiative Observational Study, *Ann Intern Med* 139:97, 2003.
2021. **An T, Hao J, Sun S, Li R, Yang M, Cheng G, Zou M**, Efficacy of statins for osteoporosis: a systematic review and meta-analysis, *Osteoporos Int* 28(1):47, 2017.
2022. **Morton DJ, Barrett-Connor EL, Edelstein SL**, Thiazides and bone mineral density in elderly men and women, *Am J Epidemiol* 139:1107, 1994.
2023. **Xiao X, Xu Y, Wu Q**, Thiazide diuretic usage and risk of fracture: a metaanalysis of cohort studies, *Osteoporos Int* 29(7):1515, 2018.
2024. **Chow RK, Harrison JE, Brown CF, Hajek V**, Physical fitness effect on bone mass in postmenopausal women, *Arch Phys Med Rehabil* 67:231, 1986.
2025. **Dalsky G, Stocke KS, Ehsani AA, Slatopolsky E, Lee WC, Birjes J Jr**, Weight-bearing exercise training and lumbar bone mineral content in postmenopausal women, *Ann Intern Med* 108:824, 1988.
2026. **Cavanagh DJ, Cann CE**, Brisk walking does not stop bone loss in postmenopausal women, *Bone* 9:201, 1988.
2027. **Brooke-Wavell K, Jones PRM, Hardman AE**, Brisk walking reduces calcaneal bone loss in postmenopausal women, *Clin Sci* 92:75, 1997.
2028. **Ebrahim S, Thompson PW, Baskaran V, Evans K**, Randomized placebo-controlled trial of brisk walking in the prevention of postmenopausal osteoporosis, *Age Ageing* 26:253, 1997.
2029. **Kohrt WM, Snead DB, Slatopolsky E, Birge SJ Jr**, Additive effects of weight-bearing exercise and estrogen on bone mineral density in older women, *J Bone Miner Res* 10:1303, 1995.
2030. **Feskanich D, Willett W, Colditz GA**, Walking and leisure-time activity and risk of hip fracture in postmenopausal women, *JAMA* 288:2300, 2002.
2031. **Hopper JL, Seeman E**, The bone density of female twins discordant for tobacco use, *N Engl J Med* 330:387, 1994.
2032. **Krall EA, Dawson-Hughes B**, Smoking and bone loss among postmenopausal women, *J Bone Miner Res* 6:331, 1991.
2033. **Kiel DP, Felson DT, Hannan MT, Anderson JJ, Wilson PW**, Caffeine and the risk of hip fracture: the Framingham Study, *Am J Epidemiol* 132:675, 1990.
2034. **Barrett-Connor E, Chang JC, Edelstein SL**, Coffee-associated osteoporosis offset by daily milk consumption, *JAMA* 271:280, 1994.
2035. **Greenspan SL, Myers ER, Maitland LA, Resnick NM, Hayes WC**, Fall severity and bone mineral

density as risk factors for hip fracture in ambulatory elderly, *JAMA* 271:128, 1994.

2036. **Armstrong AL, Osborne J, Coupland CAC, MacPherson MB, Bassey EJ, Wallace WA**, Effects of hormone replacement therapy on muscle performance and balance in post-menopausal women, *Clin Sci* 91:685, 1996.
2037. **Eklblad S, Lönnberg B, Berg G, Ödkvist L, Ledin T, Hammar M**, Estrogen effects on postural balance in postmenopausal women without vasomotor symptoms: a randomized masked trial, *Obstet Gynecol* 95:278, 2000.
2038. **Bemben DA, Langdon DB**, Relationship between estrogen use and musculoskeletal function in postmenopausal women, *Maturitas* 42:119, 2002.
2039. **Ribom EL, Piehl-Aulin K, Ljunghall S, Ljunggren O, Naessén T**, Six months of hormone replacement therapy does not influence muscle strength in postmenopausal women, *Maturitas* 42:225, 2002.
2040. **Brown M, Birge SJ, Kohrt WM**, Hormone replacement therapy does not augment gains in muscle strength or fat-free mass in response to weight-bearing exercise, *J Gerontol* 52A:B166, 1997.
2041. **Randell KM, Honkanen RJ, Komulainen MH, Tuppurainen MT, Kroger H, Saarikoski S**, Hormone replacement therapy and risk of falling in early postmenopausal women—a population-based study, *Clin Endocrinol* 54:769, 2001.
2042. **Parker MJ, Gillespie LD, Gillespie WJ**, Hip protectors for preventing hip fractures in the elderly, *Cochrane Database Syst Rev* (3):CD001255, 2003.
2043. **Lukert BP, Johnson BE, Robinson RG**, Estrogen and progesterone replacement therapy reduces glucocorticoid-induced bone loss, *J Bone Miner Res* 7:1063, 1992.
2044. **Hall GM, Daniels M, Doyle DV, Spector TD**, Effect of hormone replacement therapy on bone mass in rheumatoid arthritis patients treated with and without steroids, *Arthritis Rheum* 37:1499, 1994.
2045. **Adachi JD, Saag KG, Delmas PD, Liberman UA, Emkey RD, Seeman E, Lane NE, Kaufman JM, Poubelle PE, Hawkins F, Correa-Rotter R, Menkes CJ, Rodriguez-Portales JA, Schnitzer TJ, Block JA, Wing J, McIlwain HH, Westhovens R, Brown J, Melo-Gomes JA, Gruber BL, Yanover MJ, Leite MO, Siminoski KG, Nevitt MC, Sharp JT, Malice MP, Dumortier T, Czachur M, Carofano W, Daifotis A**, Two-year effects of alendronate on bone mineral density and vertebral fracture in patients receiving glucocorticoids: a randomized, double-blind, placebo-controlled extension trial, *Arthritis Rheum* 44:202, 2001.
2046. **Reid DM, Devogelaer J-P, Saag KG, Roux C, Lau C-S, Regionster J-Y, Papanastasiou P, Ferreira A, Hartl F, Fashola T, Mesenbrink P, Sambrook PN; for the HORIZON Investigators**, Zoledronic acid and risedronate in the prevention and treatment of glucocorticoid-induced osteoporosis (HORIZON): a multicentre, double-blind, double-dummy, randomised controlled trial, *Lancet* 373:1253, 2009.
2047. **Yang YX, Lewis JD, Epstein S, Metz DC**, Long-term proton pump inhibitor therapy and risk of hip fracture, *JAMA* 296:2947, 2006.
2048. **Vestergaard P, Rejnmark L, Mosekilde L**, Proton pump inhibitors, histamine H2 receptor antagonists, and other antacid medications and the risk of fracture, *Calcif Tissue Int* 79:76, 2006.
2049. **Kahn S, Haffner SM, Heise MA, Herman WH, Holman RR, Jones NP, Kravitz BG, Lachin JM, O'Neill MC, Zinman B, Viberti G; ADOPT Study Group**, Glycemic durability of rosiglitazone, metformin, or glyburide monotherapy, *N Engl J Med* 355:2427, 2006.
2050. **Grey A, Bolland M, Gamble G, Wattie D, Horne A, Davidson J, Reid JR**, The peroxisome proliferator-activated receptor-gamma agonist rosiglitazone decreases bone formation and bone mineral density in healthy postmenopausal women: a randomized, controlled trial, *J Clin Endocrinol Metab* 92:1305, 2007.
2051. **Cummings SR, Palermo L, Browner W, Marcus R, Wallace R, Pearson J, Blackwell T, Eckert S, Black D**, Monitoring osteoporosis therapy with bone densitometry: misleading changes and regression to the mean. Fracture Intervention Trial Research Group, *JAMA* 283:1318, 2000.
2052. **Adami S, Giannini S, Bianchi G, Sinigaglia L, Di Munno O, Fiore CE, Minisola S, Rossini M**, Vitamin D status and response to treatment in post-menopausal osteoporosis, *Osteoporos Int* 20:239, 2009.
2053. **Komulainen M, Kroger H, Tuppurainen MT, Heikkinen AM, Honkanen RJ, Saarikoski S**, Identification of early postmenopausal women with no bone response to HRT: results of a five-year clinical

trial, *Osteoporos Int* 11:211, 2000.

2054. **Gavaler JS**, Thoughts on individualizing hormone replacement therapy based on the postmenopausal health disparities study data, *J Womens Health* 12:757, 2003.

# Transgender Endocrinology

Individuals whose perception of their own gender identity, or those whose preferred gender self, differs from their natal (assigned at birth) sex are classified as transgender (TG). The existence of TG individuals has been recorded from the earliest civilizations, dating back to 1503 B.C. when Queen Hatchepsut dressed as a male and donned a fake beard during her Egyptian rule, preferring the title of King.<sup>1</sup> The 20th century, with broadening management options (medical and surgical) and an increasing interest in the underpinnings as well as sequelae of gender incongruence, can be recognized as a turning point for TG individuals. Magnus Hirschfield and Harry Benjamin, both considered as pioneers in the field, described transgenderism; they advocated for patients who sought relief from their distress by choosing to live according to their perceived gender.<sup>2,3</sup> With the addition of testosterone and diethylstilbestrol in the therapeutic armamentarium in the 1930s, hormonal treatment became a realistic option for TG individuals.<sup>4,5,6</sup> Gender-affirming surgery was similarly being explored and experimentally attempted in Europe as early as the 1930s; however, it was not until the late 1960s that gender reassignment surgery was successfully attempted in the United States.<sup>3,7</sup>

In 2010, one in five TG adults reported being denied medical treatment, harassed, or disrespected by a health care provider.<sup>8</sup> Although more health insurance programs are now offering medical coverage for TG services, this group continues to be underserved and discriminated against in the medical community.<sup>9</sup> In recent years, reputable professional societies such as The Endocrine Society and the World Professional Association for Transgender Health (WPATH) have taken the lead in establishing and promoting standard clinical guidelines for the management and treatment of TG populations.<sup>3,10</sup>

# NOMENCLATURE

---

Historically, the term “transsexual” was used to describe individuals whose gender identity did not align with their birth sex and their preference to utilize assistance to achieve transition from natal to their desired sex. However, it must be noted that not all TG persons wish to “transition.” Additional terms that, although often used interchangeably, are distinguishable include gender dysphoria, gender nonconforming, or gender incongruent. The clear difference between gender dysphoria and gender incongruent or gender nonconforming is that persons with “dysphoria” have clear discomfort or distress due to the inability to express their true gender identity. Since the terminology is rapidly evolving, a table of the common terms is presented to familiarize readers with the common nomenclature (Table 18.1). **The spectrum of nomenclature holds an important concept—that a person’s gender identity is not necessarily binary (male or female).** There are individuals that at any stage of life may relate to different points on the spectrum or may never associate with any particular gender.

## TABLE 18.1 Commonly Used Terminology



Terminology	Definition
Cisgender	Term used for people who identify with their sex designated at birth
Disorders of Sex Development (DSD)	Congenital conditions in which development of the chromosomal, gonadal, or anatomic sex is atypical
Gender	Personal perception of how he/she sees himself/herself
Gender Dysphoria	Discomfort or distress that is caused by a discrepancy between a person's gender identity and that person's sex assigned at birth
Gender Expression	External manifestation of gender, expressed through one's name, pronouns, clothing, haircut, behaviors, and vice and body characteristics
Gender Identity	A person's intrinsic sense of being male, female, or an alternative gender (i.e., eunuch, genderqueer, pangender, gender fluid, or a gender)
Gender Identity Disorder	Term used for gender dysphoria/gender incongruence in previous versions of the <i>Diagnostic Statistical Manual of Mental Disorders</i> , 4th ed., Text Rev (DSM IV-TR) <sup>16</sup>
Gender Incongruence	Categorical term used when the gender identity and/or gender expression differs from what is typically associated with the designated gender
Gender Nonconformity	Extent to which a person's gender identity or expression differs from the cultural norms for the particular gender
Sex	Biologic phenotype present at birth (male, female)
Transgender	Umbrella term for people whose gender identity and/or gender expression differs from what is associated with their sex designated at birth
Transgender Female (Transwoman, Male to Female, MTF, Transgender Woman)	Used to describe an individual assigned male at birth but who identifies and lives as a female
Transgender Male (Transman, Female to Male, FTM, Transgender Man)	Used to describe an individual assigned female at birth but who identifies and lives as a male
Transsexual	Historic term used to refer to individuals who have permanently transitioned through medical interventions or have a desire to do so

Data from **Hembree WC, Cohen-Kettenis PT, Gooren L, Hannema SE, Meyer WJ, Murad MH, Rosenthal SM, Safer JD, Tangpricha V, T'Sjoen GG**, Endocrine treatment of gender-dysphoric/gender-incongruent persons: an Endocrine Society Clinical Practice guideline, *J Clin Endocrinol Metab* 102(11):1–35, 2017; **World Professional Association for Transgender Health**, Standards of care for the health of transsexual, transgender, and gender nonconforming people. Available at [http://www.wpath.org/site\\_page.cfm?pk\\_association\\_webpage\\_menu=1351&pk\\_association\\_webpage=3926](http://www.wpath.org/site_page.cfm?pk_association_webpage_menu=1351&pk_association_webpage=3926) (Accessed March 14, 2018); and **Lee PA, Houk CP, Ahmed SF, Hughes IA**, Consensus statement on management of intersex disorders, *Pediatrics* 118(2):488, 2006.<sup>11</sup>

# PREVALENCE

---

Estimates on the population prevalence of TG individuals have been fraught with error, given the likely underreporting based on social and cultural stigma. In 2016, it was estimated that 0.6% of adults in the United States, or 1.4 million individuals, were identified as TG.<sup>12</sup> Western European studies suggest a 3 to 1 ratio of transgender females (TGF, or natal male with preferred female sex) to transgender males (TGM, or natal female with preferred male sex). This ratio however cannot be generalized beyond Western Europe given that different cultures have varying levels of tolerance for TG individuals, with resulting barriers for TGs to fully express themselves.<sup>13,14</sup> The number of TG individuals has been steadily increasing; however, it is likely that the incidence has not changed, but rather, social acceptance has contributed to a willingness to identify as TG.<sup>15</sup> Differences by age also exist, with younger adults being more likely to identify as TG compared to older adults. In the United States, an estimated 0.7% of adults between ages 18 and 24 years, 0.6% of adults of ages between 25 and 64, and 0.5% of adults 65 years and older identify as TG.<sup>12</sup>

# **BIOLOGIC DETERMINANTS OF GENDER IDENTITY**

---

# Hormones

Gender identity and gender expression likely involves a complex relationship of biologic, environmental, and cultural factors. In an effort to comprehend gender identity, studies on patients with disorders of sexual development (DSD) have been used as a model to further understand the relevance of both phenotype and the hormonal milieu on gender identity.

Gender ambiguity or feminization of external genitalia in genetic males from androgen synthesis disorders such as 5 $\alpha$ -reductase-2 (5 $\alpha$ -RD-2) and 17 $\beta$ -hydroxysteroid dehydrogenase-3 (17 $\beta$ -HSD-3) deficiencies is well described, and these individuals are commonly raised as females.<sup>17</sup> In the case of 5 $\alpha$ -RD-2 deficiency, depending on the severity of the enzymatic deficiency, the degree of testosterone conversion to the more potent androgen dihydrotestosterone may be compromised, which can result in varying levels of inadequacies in masculinization of the external genitalia. The spectrum of DSD seen in 5 $\alpha$ -RD-2-deficient patients ranges from complete feminization to varying degrees of ambiguity of genitalia in a genetic male. In these cases, testosterone-mediated neurocognitive modulation of the brain is unaffected as testosterone levels, and signals to nonsexual organs are intact. In contrast to 5 $\alpha$ -RD-2 deficiency, those with 17 $\beta$ -HSD-3 deficiency are exposed to in utero testosterone deficiency.<sup>17</sup> If prenatal androgen exposure is critical for gender identity, then genetic males with 5 $\alpha$ -RD-2 deficiency who are exposed to normal testosterone levels in utero should identify as male regardless of the anatomy of their external genitalia. However, gender role changes from female to male were seen in only 56–63% of individuals with 5 $\alpha$ -RD-2 deficiency and in 39–64% of 17 $\beta$ -HSD-3-deficient individuals.<sup>17</sup> These findings raise doubts regarding the potential role of prenatal brain exposure to androgens as the only major contributor to gender identity development.

In genetic females (46, XX) with gender ambiguity, such as those with congenital adrenal hyperplasia (CAH), there is typically an excess of prenatal androgen exposure (discussed in detail in [Chapter 13](#)). Interestingly, although studies have shown that this exposure to excess androgens during fetal development may predispose to masculinization of human behavior, data are inconclusive regarding whether 46, XX patients with CAH have a higher propensity to suffer from gender dysphoria.<sup>18,19</sup> A review of 263 genetic females with CAH examined the prevalence of gender dysphoria in this population; while the large majority, 94.8% (n = 250), did not manifest any gender identity issues, 5.2% (n = 13) of these genetic females manifested evidence of gender dysphoria; this prevalence is higher than seen in the general population.<sup>20</sup> In a cross-sectional study of twenty-two 46, XX CAH patients with ambiguous genitalia, 3 were reared as males and 19 as females. Among the 19 female patients, 17 (89.5%) were found to have no evidence of gender dysphoria using the Gender Identity/Gender

Dysphoria Questionnaire, and 2 of the 3 males also did not show any dysphoria.<sup>21</sup> These studies clearly indicate that more factors are involved in gender expression than simply prenatal hormone exposure.

In contrast to the DSD cases previously mentioned, Reiner and Gearhart studied 16 genetic males (46, XY) with cloacal exstrophy, a complex pelvic defect occurring during embryogenesis which presents with structural anomalies to the lower abdominal wall and includes phallic absence or inadequacy (no hormonal aberrations).<sup>22</sup> Fourteen of the 16 subjects with cloacal exstrophy were assigned female sex at birth due primarily to the appearance of their external genitalia.<sup>3,22</sup> The 16 genetic male subjects, who ranged in age from 5 to 16 years of age, were assessed on their sexual role and sexual identity via questionnaires. Interestingly, 8 of the 14 patients (57.1%) assigned female identity identified as male, whereas the two cases assigned male at birth maintained a male identity.<sup>14,22</sup> Since these individuals have intact androgen exposure and only manifest structural defects, one would expect that all individuals would identify as male. These findings again underscore the concept that there is a complex relationship involved in gender identity that encompasses more than simply hormonal predisposition.

Lastly, physiologic differences among trans- and cisgender persons have been examined without any supportive evidence to this end. Circulating levels of sex hormones are comparable between untreated TG and cisgender individuals.<sup>3,23</sup>

# Structural Determinants

The brain is known to have several regions that differ in organization between men and women.<sup>24,25,26</sup> In particular, postmortem studies evaluating the brain structures of TG individuals have found changes in the central subdivision of the bed nucleus of the stria terminalis (BSTc). BSTc is a limbic structure that plays an important role in controlling autonomic, neuroendocrine, and behavioral responses. This region is of particular interest since it is sexually dimorphic and its size and cell number have been related to gender identity.<sup>24</sup> Chung et al. studied the BSTc of 50 brains from individuals who ranged in age from prenatal to adult life.<sup>24</sup> The divergence of BSTc was not shown to occur prenatally or neonatally.<sup>24</sup> Interestingly, the region's volume appears to become sexually dimorphic after puberty with significant changes seen continuing into adulthood.<sup>24</sup> Although these findings may help explain the phenomenon of new onset gender dysphoria manifesting in adolescents at puberty, there are others who acknowledge a strong sense of gender incongruence since childhood. In a separate study, the brains of six TG females were evaluated and found that the size and staining of the BSTc were within female range, whereas the one TG male had a BSTc within male range.<sup>27,28</sup> In contrast, the cisgender males and females all had BSTc characteristics consistent with their respective gender.<sup>27,28</sup> The differences in BSTc staining seen among TG patients were independent of sex hormone utilization or sexual orientation. Given the few studies and small sample sizes, more research is clearly needed to clarify our understanding if regional brain anatomy holds a causative relevance for gender identity.

# Genetics

To date, there have not been any specific genes associated with TG individuals. However, twin studies have suggested a possible genetic link.<sup>3,29,30</sup> In a case series by Heylens et al., the investigators found a 39.1% concordance rate for gender disorders in 23 monozygotic male and female twin pairs, but no concordance was detected among the 21 same-sex dizygotic or seven opposite-sex twin pairs.<sup>30</sup> Gómez-Gil et al. studied nontwin siblings of 995 TG individuals to evaluate the co-occurrence of gender identity disorder.<sup>31</sup> Of the 2,527 siblings, 12 (1:211) were also TG, suggesting that while the likelihood is slim, biologic siblings of persons with gender identity disorder have a higher risk than the reported prevalence in the general population.<sup>31</sup>

# Environment

Theories regarding the role of the environment and child-rearing in forming one's gender identity have been suggested, although there is little evidence to support this conjecture.<sup>32</sup> Environmental endocrine-disrupting hormones may have a role, but this theory has not been adequately investigated.

In summary, an individual's gender identity likely involves multiple interrelating factors of which there currently are many unknowns. More studies are clearly needed to better grasp the possible and plausible mechanisms that can explain the spectrum of prevalent gender identities.



# TRANSGENDER HEALTH AND WELLNESS

A multidisciplinary team approach has been the cornerstone to the medical management and treatment of TG persons. In the past, such individuals were often underserved due to limited medical resources, social stigma, and provider inexperience. Due to the complexity of medical issues that TG patients often endure, each provider on the team serves a critical role during the transition process. The managing team composition can vary depending on the needs and goals of the TG individual (Table 18.2). An integral role of reproductive endocrinologists on the team is increasingly recognized given the breadth and depth of their expertise; reproductive endocrinologists can assist with gender-affirming hormonal therapy, offer timely counseling on issues of fertility, offer fertility preservation options, as well as provide general gynecologic care.

**TABLE 18.2 Multidisciplinary Team Approach to Transgender Care**

Mental Health Provider	Diagnose gender dysphoria/gender incongruence, and provide support and guidance throughout transition particularly with social and interpersonal interactions.
Primary Care Provider	Coordinate and treat any underlying medical concerns and ensures routine health screening for all remaining birth sex organs, assist with hormone management.
Endocrinologist	Provide hormone management regimens for the preferred gender, while suppressing natal hormones.
Gynecologist	Provide medical and surgical support for all gynecologic needs.
Urologist	Provide medical and surgical support for all urologic needs.
Reproductive Endocrinologist	Counsel on reproductive cryopreservation options, treat with assisted reproductive techniques if needed, assist with hormone management.
Plastic Surgeon	Perform gender-affirming and cosmetic surgeries in accordance with patients' preferred gender.
Speech Therapist	Assist with voice training in congruence with preferred gender.
Dermatology/Aesthetician	Perform electrolysis or laser hair removal on unwanted facial/body hair for transgender females.

# Mental Health

The TG community has a unique set of mental health issues as these persons often endure victimization, discrimination, and physical violence due to their perceived differences. A higher likelihood of concomitant psychological conditions (e.g., anxiety, depression) is well described in TG individuals.<sup>33,34</sup> In the United States alone, nearly 41% of adult TG individuals have attempted suicide in their lifetime, an occurrence that is strikingly higher than the 4.6% attempted suicide rate that is reported for the overall U.S. population.<sup>35</sup>

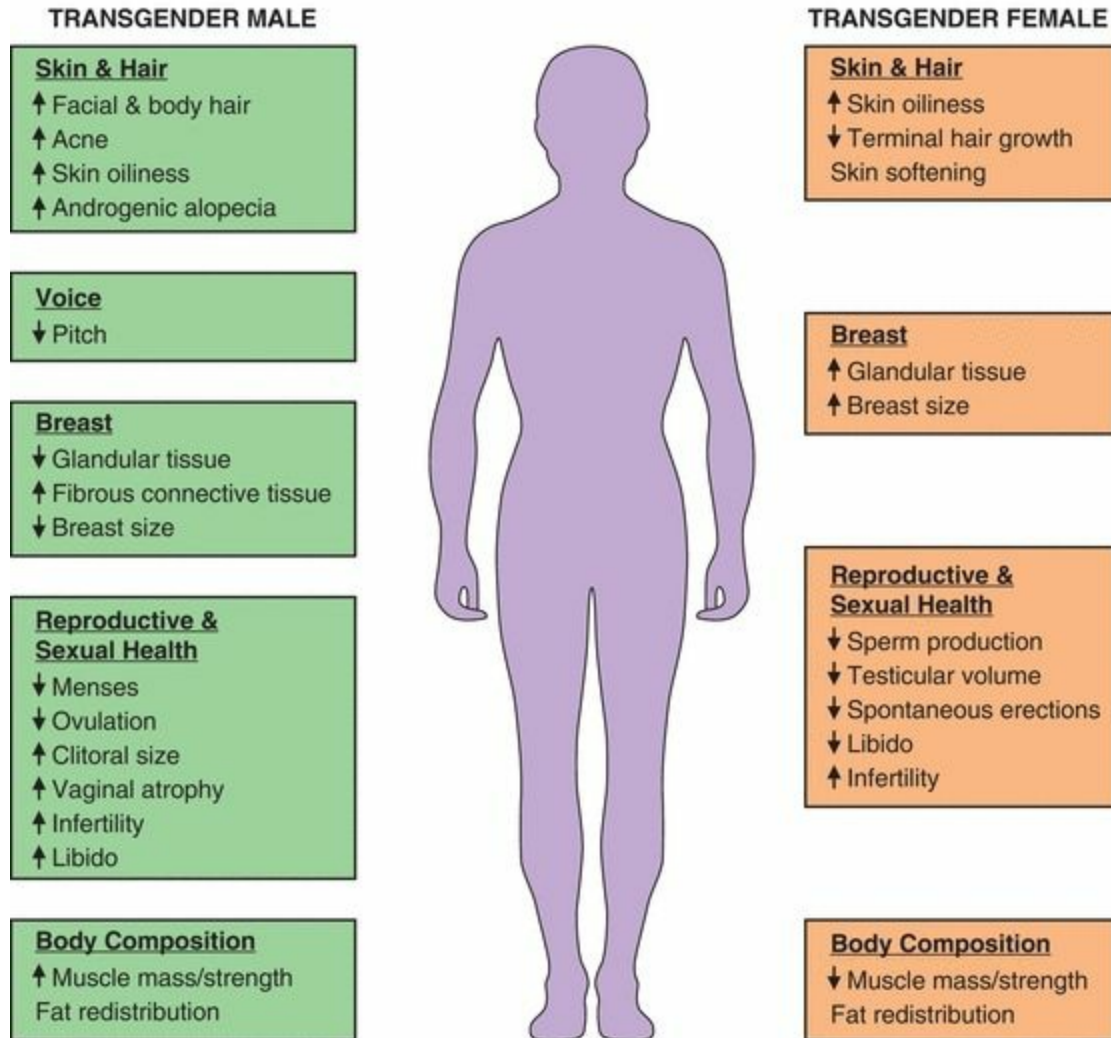
Participation of a trained mental health provider (MHP) is critical to any team approach to TG health care. The MHP participating in TG care must (1) be trained in diagnosing gender dysphoria and/or gender incongruence, (2) be familiar with using the Diagnostic and Statistical Manual of Mental Disorders (DSM-V) or the World Health Organization International Statistical Classification of Disease and Related Health Problems (ICD) for diagnostic purposes, and (3) be able to distinguish gender dysphoria and gender incongruence from other psychiatric conditions that may have similar features (e.g., body dysmorphic disorder).<sup>36,37</sup> The MHP should also be able to educate and provide guidance for a patient wishing to transition into his/her desired gender. Lastly, the MHP should be qualified to assess the person's psychosocial needs and be able to refer the person for further treatment (hormone therapy, surgery) when deemed appropriate. The need for participation of a MHP is evident at the earliest stage of evaluation and should be prioritized to remain available through the life journey of a TG individual.<sup>35</sup>

# GENDER-AFFIRMING HORMONE THERAPY IN MANAGEMENT OF ADULT TRANSGENDER PATIENT

---

One of the key components of the gender transition process involves the initiation of gender-affirming hormone treatment. For many TG individuals, consideration of hormone therapy is the first step toward aligning their physical appearance with their true gender identity (**Figure 18.1**). Several studies have shown that individuals who use gender-affirming hormones have improvement in gender dysphoria, perceived stress, anxiety, and social distress.<sup>38,39,40</sup> In a meta-analysis of 28 studies, which evaluated 1,833 TG patients who initiated gender-affirming hormone therapy, those who received hormone therapy reported an 80% (95% CI = 72–88%) improvement in their gender dysphoria, while 78% (95% CI = 61–81%) described improvement in their overall psychological symptoms.<sup>41</sup> The decision to initiate hormone treatment and choice of hormone regimens must be individualized in order to safely and effectively achieve the desired goal of the patient. Timely intervention with hormone therapy can make an enormous impact not only on the individual goals for their physical appearance but equally important on their overall mental health and stability.

## EFFECTS OF GENDER AFFIRMING HORMONE THERAPY

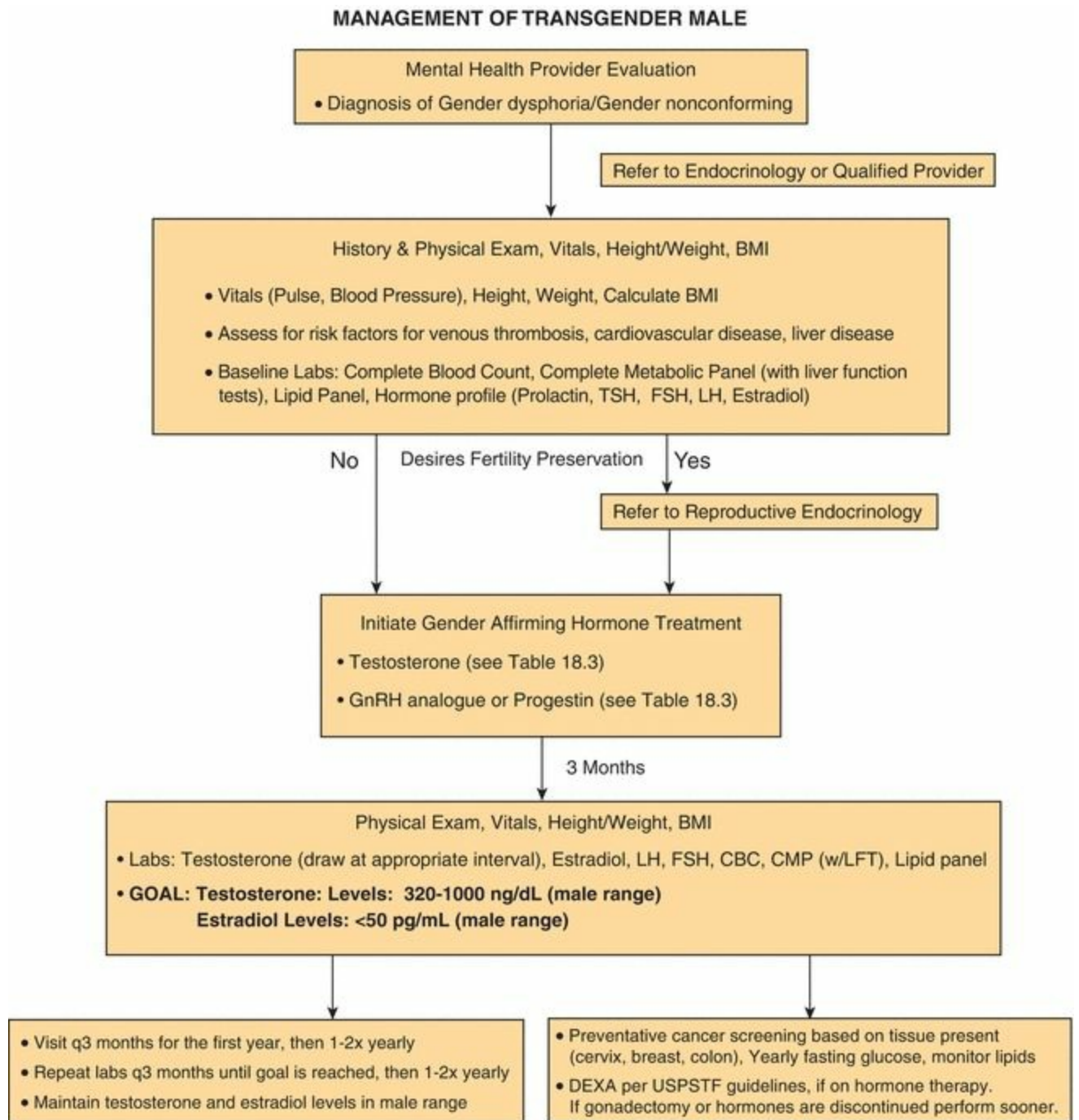


Modified with permission from **Irwig M**, Testosterone therapy for transgender men, *Lancet Diabetes Endocrinol* 5(4):301, 2017.<sup>42</sup>

# Masculinizing Hormone Therapy in Management of Transgender Male

Masculinizing hormone therapy is utilized in managing TG males (or female to male TG). The goal is to achieve a male phenotype through the use of a combination of hormones that stimulate the development of male secondary sex characteristics (deepening of voice, excessive facial and body hair, gain in muscle mass) while suppressing female secondary sex characteristics (regression in breast size, loss of female pattern distribution of body fat). These goals are achieved by administering potent androgens (such as testosterone). Added benefit may be achieved through concomitant suppression of endogenous ovarian estrogen production. The use of gonadotropin-releasing hormone agonists (GnRHa) to suppress ovarian estradiol production is typically only needed until male testosterone levels are reached, at which point the persistently high circulating testosterone levels can serve to suppress the hypothalamic-pituitary-ovarian axis, and at this point, GnRHa can be discontinued.

The algorithm for the evaluation and treatment of TGMs can provide guidance when treating these individuals ([Figure 18.2](#)). A number of testosterone regimens are currently available and outlined in [Table 18.3](#).<sup>3,43</sup> In the United States, testosterone cypionate and enanthate are the most commonly utilized formulations; choice of androgen and regimen should take into consideration safety, availability, cost, as well as patient preference for route and ease of administration. The goal of masculinizing hormone therapy is to attain circulating levels of testosterone and estradiol in physiologic male range: testosterone 320–1,000 ng/dL and estradiol less than 50 pg/mL.<sup>3,10</sup> The timing of when to draw serum testosterone levels during treatment is determined based on the pharmacokinetics and route of the utilized hormone formulation. For example, if testosterone enanthate intramuscular injections are being utilized, a serum testosterone level should be timed midway between injections and adjustments made based on the levels obtained as well as the clinical response ([Table 18.3](#)).<sup>15</sup>



**FIGURE 18.2**

**TABLE 18.3 Testosterone Formulations for Transgender Males**

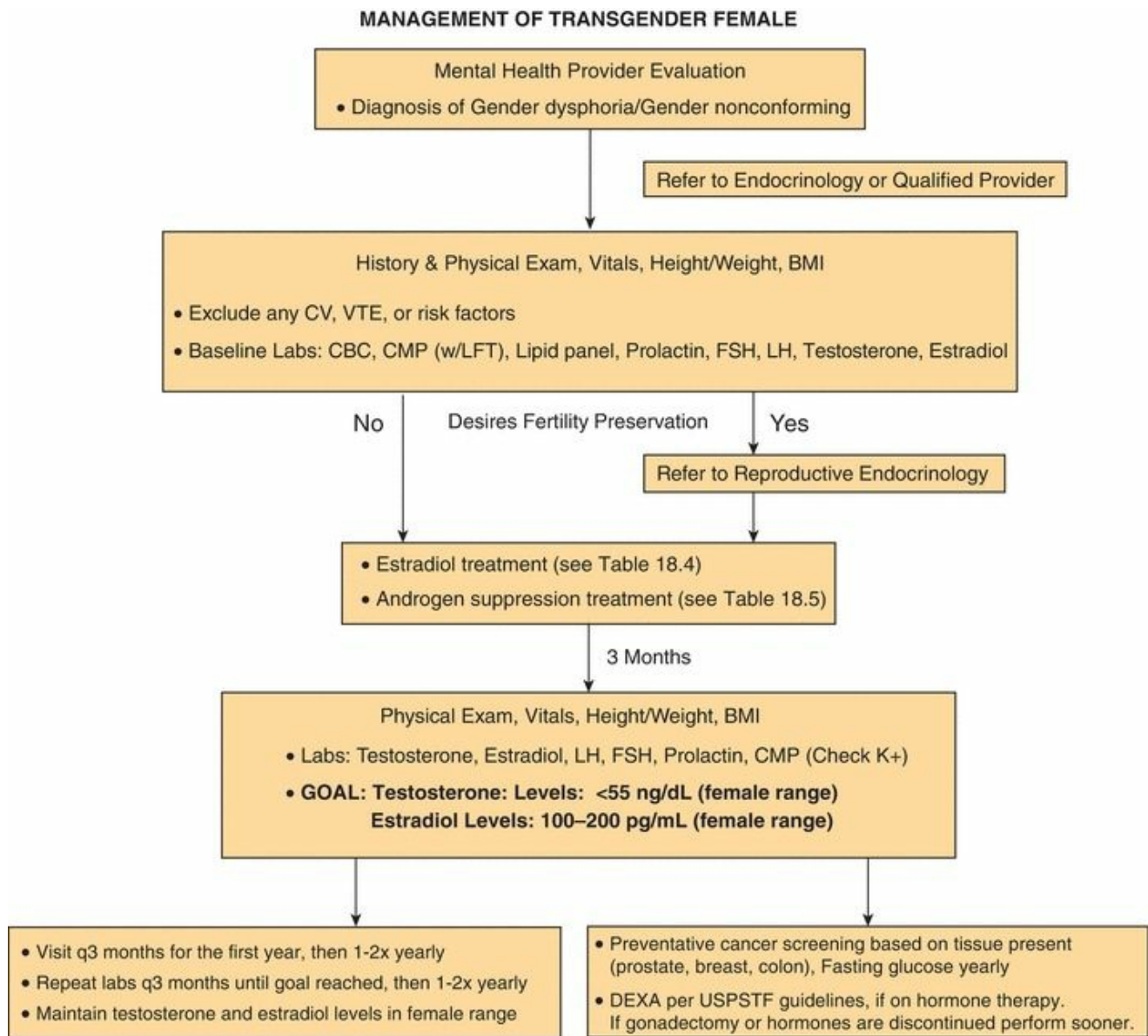
	Route	Dose	Measure	Advantage (A)/Disadvantage (D)
Testosterone Enanthate/ Cypionate	IM/SQ	100–200 mg/q2wk (half if weekly dosing)	Midway between injections	A: Inexpensive, highly effective at reaching target levels, readily available D: Injection, erythrocytosis
Testosterone Gels	Topical	1%: 25–100 mg/day 1.6%: 50–100 mg/day	Anytime (After 1 wk of use)	A: Consistent concentration D: Expensive, skin to skin contact
Testosterone Transdermal Patch	Topical	2.5–7.5 mg/day	Anytime (After 1 wk of use)	A: Consistent concentration D: Expensive, skin irritation, falls off with moisture/exercise
Testosterone Pellets	SQ implant	150–450 mg/q3–6mo	Anytime (After 1 wk of use)	A: Consistent concentrations, infrequent dosing D: Invasive, inflexible dosing, infection risk
Testosterone Buccal	Buccal	30 mg twice/day	Anytime (After 1 wk of use)	D: Expensive, gum irritation, taste alterations, requires compliance
Testosterone Undecanoate	Oral	40–80 mg/2–3× day	Anytime (levels can be inconsistent)	D: Variable concentrations, requires compliance, limited availability in the United States
Testosterone Undecanoate	IM	1,000 mg/12 wk	Prior to next dose (trough)	A: Infrequent dosing D: Expensive, injection site pain, limited availability in United States

Routine physical examination and laboratory surveillance for possible adverse reactions (i.e., polycythemia associated with use of androgens) should initially be performed every 3 months for the first year of hormone treatment. Visits can become less frequent once the goal hormone levels are reached or as the provider deems necessary.

Although the external physical changes with testosterone use are clearly evident, TG males may also experience changes in their sexual and emotional health. Many of these changes can be seen within the first 6 months of testosterone treatment to include acne, body fat redistribution, and increased muscle mass. Studies report that in 55–84% of TGMs, menses ceases by 6 months and nearly all by 1 year of androgen therapy.<sup>44, 45, 46</sup> The time to menstrual cessation following initiation of androgen therapy may vary and can be achieved with standard testosterone treatment alone (50–60 mg/wk).<sup>44</sup> If intermittent spotting occurs, or if menses becomes bothersome, progesterone can be added to the hormone regimen.<sup>44</sup> **Figure 18.1** depicts the masculinizing effects of testosterone in TG males.

# Feminizing Hormone Therapy in Management of Transgender Female

Feminizing hormone therapy is utilized in managing TG females (or male to female TG). The goal is to achieve a female phenotype through the use of a combination of hormones that stimulate the development of female secondary sex characteristics (breast development, female pattern body fat distribution) while suppressing male secondary sex characteristics (slowing of facial and bodily hair growth). These goals are achieved by administering estrogen. Added benefit may be achieved through concomitant suppression of endogenous testicular androgen production and/or antagonizing tissue effects of androgens through simultaneous use of antiandrogens. **Figure 18.3** provides an algorithm to guide evaluation and management of TG female.





## FIGURE 18.3

There are many different estrogen formulations (i.e., pill, patch, topical), any of which can be used to achieve the desired effects (Table 18.4). Oral conjugated estrogens 2.5–7.5 mg and oral 17 $\beta$ -estradiol 2–6 mg daily are popular regimens since they are easy to administer and readily available. Although estrogen therapy can suppress androgens, usually a GnRHa or antiandrogen is also necessary for best results. GnRHa suppresses pituitary gonadotropin secretion resulting in a decrease in testicular production of testosterone. Similarly, antiandrogens work primarily by blocking its activity at the level of androgen receptors (i.e., spironolactone and flutamide) or by reducing the conversion of testosterone to the more potent androgen dihydrotestosterone (i.e., finasteride) (Table 18.5); antiandrogens are discussed in detail in Chapter 12. The goal of feminizing hormone treatment is to achieve circulating hormone levels that are within normal female range: estradiol 100–200 pg/mL and testosterone less than 55 ng/dL.<sup>3, 10</sup>

### TABLE 18.4 Estrogen Formulations for Transgender Females

	Route	Dose	Monitor	Advantage (A)/Disadvantage (D)
Conjugated Estrogens	Oral	2.5–7.5 mg/day	Anytime (levels can be inconsistent)	A: Inexpensive, readily available, highly effective D: Requires compliance, difficult to monitor levels, VTE risk
17- $\beta$ Estradiol	Oral	2–6 mg/day	Anytime (levels can be inconsistent)	A: Inexpensive, readily available, highly effective D: Requires compliance, VTE risk
Estradiol Valerate	IM	5–20 mg/q2wk	Midway between injections	A: Infrequent dosing D: Expensive, injections site pain
Estradiol Cypionate	IM	2–10 mg/qwk	2–4 days after injection (peak)	A: Infrequent dosing D: Expensive, injections site pain
Estradiol Transdermal Patch	Topical	0.25–0.2 mg/day 0.1–0.4 mg/2 $\times$ week	Anytime (after 1 wk of use)	A: Consistent concentration, lower VTE risk D: Expensive, skin irritation, falls off with moisture/exercise, difficult to titrate doses

### TABLE 18.5 Antiandrogen Treatment Regimens for Transgender Female

Medication	Dose	Mode of Action
<b>Antiandrogens</b>		
• Spironolactone	100–200 mg/day	Androgen receptor blocker and decreases testosterone synthesis
• Finasteride	1–5 mg/day	5- $\alpha$ reductase inhibitor, blocks conversion of testosterone to DHT
• Dutasteride	0.5 mg/day	5- $\alpha$ reductase inhibitor, blocks conversion of testosterone to DHT
<b>GnRH Agonists</b>		
• Leuprolide Acetate	3.75 mg/mo 11.25 mg/q3mo	Suppresses gonadotropin release and subsequently lowers sex steroids
• Histrelin Acetate Subcutaneous Implant	50 mg/q12mo	
<b>Progestins</b>		
• Medroxyprogesterone Acetate	5–10 mg/day	Progestin with antiandrogenic properties
• Cyproterone Acetate <sup>a</sup>	25–30 mg/day	Progestin with antiandrogenic properties

IM, intramuscular.

<sup>a</sup>Not available in the United States.

Data from **Hembree WC, Cohen-Kettenis PT, Gooren L, Hannema SE, Meyer WJ, Murad MH, Rosenthal SM, Safer JD, Tangpricha V, T’Sjoen GG**, Endocrine treatment of gender-dysphoric/gender-incongruent persons: an Endocrine Society Clinical Practice guideline, *J Clin Endocrinol Metab* 102(11):1, 2017; **World Professional Association for Transgender Health**, Standards of care for the health of transsexual, transgender, and gender nonconforming people. Available at [http://www.wpath.org/site\\_page.cfm?pk\\_association\\_webpage\\_menu=1351&pk\\_association\\_webpage=3926](http://www.wpath.org/site_page.cfm?pk_association_webpage_menu=1351&pk_association_webpage=3926) (Accessed March 14, 2018); and **Chapkin SR, Kim F**, Ten most important things to know about caring for transgender patients, *Am J Med* 130:1238, 2017.

Physical examination and laboratory monitoring should be performed every 3 months for the first year to ensure estradiol levels are not suprathreshold and to monitor for any adverse reactions.<sup>3</sup> It can also be helpful to measure testosterone levels in order to document the degree of suppression of endogenous androgen production. Electrolytes, particularly potassium, should be monitored if spironolactone is utilized and notable changes in lipid parameters should be closely observed.

Transgender females on estrogen therapy will notice an increase in subcutaneous fat distribution, primarily around the hips, breast development, changes to skin texture, thinning of body hair, and feminization of facial features.<sup>3</sup> As female features develop, muscle strength, testicular volume, and libido will decrease.<sup>15</sup> **Figure 18.1** depicts the feminizing effects of testosterone in TGFs.

## Risks of Gender Affirming Hormone Therapy

In general, gender-affirming hormone treatment regimens are well tolerated and safe. The hormonal formulation used, dose, and the route of administration should be considered on an individualized basis in efforts to minimize risks while optimizing outcomes. Serious adverse events can be minimized by screening the patient carefully

for any comorbidity, concerning health habits, and significant family history that would confound treatment.

Polycythemia, weight gain, increased body mass index, acne, androgenic alopecia, and sleep apnea are well described with the use of masculinizing hormone therapy in TG males.<sup>3,10,47</sup> Testosterone therapy has been shown to increase triglycerides and low-density lipoprotein (LDL) while lowering high-density lipoprotein (HDL).<sup>3,48,49</sup> With additional risk factors, such as obesity and a strong family history, there may also be an increased risk of hypertension, type 2 diabetes mellitus, and cardiovascular disease.<sup>47,50</sup> Therefore, routine screening of lipids and fasting glucose levels should be considered prior to initiating hormone therapy and then periodically during maintenance to monitor for adverse metabolic effects such as hyperlipidemia and hyperglycemia. Aromatizable androgens such as testosterone can be aromatized to estrogen by end organs. While osteoporosis is not a concern for TG males on gender-affirming hormone therapy, screening of bone mineral density by dual energy x-ray absorptiometry (DEXA) should be considered for those individuals who are deemed at high risk for skeletal fragility, in those where GnRHa treatment was initiated early in life and continued for prolonged periods, in those contemplating cessation of hormone treatment or if the patient elects for premenopausal gonadectomy.<sup>3,32</sup>

The primary concern with the use of feminizing hormone therapy by TG women is the risk of venous thromboembolic (VTE) development; therefore, modifiable risk factors (i.e., smoking, obesity, hypertension) should be optimized to decrease the underlying hazard.<sup>51</sup> Historically, the previously used and now obsolete drug diethylstilbestrol was seen to cause thrombotic complications in TG females raising the concern about estrogen use within this group.<sup>3,52</sup> VTE risk associated with estrogen use is influenced by dose, route, and regimen. Although VTE risk is increased with the use of all types of systemic estrogen formulations, formulations containing ethinyl estradiol have been associated with a notably higher degree (20-fold increase) than other estrogenic formulations.<sup>50,51,53</sup> Other adverse effects related to estrogen hormone therapy include gallstones, weight gain, hypertriglyceridemia, decreased libido, hyperprolactinemia, and cardiovascular disease.<sup>3,10,50,54</sup> The route of administration may modify the risk factors, for example, transdermal estradiol may have a lower VTE risk by bypassing the first-pass liver metabolism and can be recommended for patients deemed at high risk for oral administration. Similarly, prolactinomas are typically seen with oral estradiol administration; therefore, an alternative route can be considered if this becomes an issue. Furthermore, TG females with risk factors may be predisposed to low bone mass and worsening of glycemic metabolism.<sup>50,54,55</sup> Therefore, a yearly fasting glucose levels should be obtained, and those who discontinue hormone therapy or have known risk factors should get a DEXA scan.

# GENDER DYSPHORIA IN CHILDREN AND ADOLESCENTS

---

There are notable differences between children and adolescents regarding persistence of dysphoria into adulthood. Several studies have shown that the percentage of children whose dysphoria persists into adulthood is only 12–27%, highlighting that gender dysphoria can be transient in this group.<sup>10,56,57</sup> The percentage of those individuals who become TG adults appears to be much higher among adolescents who experience unrelenting gender dysphoria into adulthood.<sup>3,10</sup> It is highly encouraged for gender dysphoric or gender nonconforming individuals to make a social transition or experience living in the new gender role and to determine whether this improves one's quality of life prior to the initiation of any hormone therapy.<sup>3</sup>

As previously highlighted, the Endocrine Society Clinical Practice Guidelines for gender dysphoria/gender noncongruence has provided guidance for medical treatment of TG individuals including adolescents.<sup>3</sup> In adolescent patients, treatment options include those deemed reversible, partially reversible, and those that are irreversible. Reversible treatments include the use of GnRH analogues or GnRH antagonists. Partially reversible treatments include the use of hormone therapy, where some physical changes can lessen upon cessation of treatment; it should be noted that medical or surgical intervention may be required (i.e., mastectomy, laser hair removal). Lastly, irreversible options include genital or gonadal surgery as well as some hormonal changes that once started are permanent.

Once the diagnosis of gender dysphoria or gender nonconforming is made by an MHP, usually with parental involvement if they maintain decision-making authority, the individual can be referred for gender-affirming hormone treatment. Prior to the decision on whether to treat children or adolescents with gender-affirming hormones, a thorough evaluation should be undertaken by a skilled provider who has an understanding of the psychopathology and developmental milestones within this vulnerable age group.

# Puberty Suppressing Hormones and Role in Transgender Care

It is commonplace to first start with treatment that is reversible given the previously highlighted indecision among this group. In efforts to mitigate harm and/or minimize exposure to the nonreversible effects of hormone therapy, it is recommended that patients avoid beginning puberty suppressing medications until the onset of puberty or Tanner stage 2 (girls, Tanner 2 breasts; boys, Tanner 2 genital).<sup>3,10</sup> Physical examination is usually sufficient to determine puberty initiation; however, evidence of gonadotropins elevation in the serum can also be obtained to verify activation of the hypothalamic-pituitary-gonadal (HPG) axis. Laboratory measurements of serum follicle-stimulating hormone (FSH), luteinizing hormone (LH), and the appropriate sex steroid (estradiol, testosterone) can be utilized to corroborate the findings on physical examination. The use of GnRHa is the preferred hormone treatment to achieve puberty suppression (Table 18.6). As previously mentioned, GnRHa suppress pituitary release of gonadotropins by desensitization of the GnRH receptors. In girls who begin GnRHa treatment at the earliest pubertal stage, breast buds may regress, and if begun after onset of menarche, menses will cease with ongoing treatment. Similarly initiation prior to puberty can restrict testicular volume and prevent onset of androgenization, whereas if begun later, ongoing treatment will arrest masculinization.<sup>3</sup> Besides the possibility of reversal of undesired features, the use of GnRHa allows the young adolescent time to determine whether hormone therapy is an intervention they still wish to pursue.

## TABLE 18.6 Puberty Induction and Suppression Strategies for Transgender Adolescents

Medication	Starting Dose	Final Adult Dose	Incremental Change (Dose/Time)
<b>Transgender Female</b>			
17β-Estradiol (Oral)	5 µg/kg/day	2–6 mg/day	Increase by 5 µg/kg/day q6mo
17β-Estradiol (Transdermal)	6.25 µg/24 h (1/4 of 25 µg patch)	50–200 µg/24 h	Increase by 12.5 µg/24 h q6mo
<b>Transgender Male</b>			
Testosterone Enanthate/ Cypionate	25 mg/m <sup>2</sup> /2 wk	100–200 mg/2 wk	Increase by 25 mg/m <sup>2</sup> /2 wk q6mo
<b>GnRH Agonist</b>			
Leuprolide Acetate	3.75 mg/mo		
	11.25 mg/q3mo		
Histrelin Acetate (Subcutaneous Implant)	50 mg/q12mo		

From Hembree WC, Cohen-Kettenis PT, Gooren L, Hannema SE, Meyer WJ, Murad MH, Rosenthal SM, Safer JD, Tangpricha V, T’Sjoen GG, Endocrine treatment of gender-dysphoric/gender-incongruent persons: an Endocrine Society Clinical Practice guideline, *J Clin Endocrinol Metab* 102(11):1, 2017.

Unlike the GnRHa analogues that have been long in use, GnRH antagonists are an expanding class of agents that offer immediate cessation of pituitary gonadotropin release by antagonizing the effects of GnRH at the level of pituitary receptors; however, long-term data on the use of GnRH antagonists in adolescents are lacking.<sup>3</sup>

Progestins, both depot and oral formulations, can be utilized in management of TG males to decelerate pubertal progression; this method was historically used for puberty suppression in girls with precocious puberty.<sup>3,58</sup> Progestins are safe and do suppress gonadotropins, although not to the level seen with GnRHa. Common progestin side effects include acne, fatigue, intermittent uterine bleeding, and headache.

For TG females, antiandrogens that suppress androgen synthesis or action can also be used as a substitute to GnRHa treatment (see Table 18.5). These alternative options could be considered in special circumstances when the cost or availability of GnRHa is limited, or in unique circumstances such as patient preference or in cases of needle phobia where injectable medications can be problematic. Most recently, an oral GnRH antagonist formulation has become available, and can be utilized as an alternative to a GnRHa.<sup>59</sup>

GnRH analogues do have some adverse side effects, which are typically reversible, and however should be kept in mind particularly in adolescents who use GnRHa for a prolonged period of time. Compromised bone mineralization is of utmost concern during this critical period of growth and should be monitored with extended GnRHa usage.

For adolescents and young TG individuals considering initiation of puberty suppression followed by gender-affirmative hormone therapy, a discussion about fertility preservation should be considered and offered (further discussion follows under heading of special considerations).

# GENDER-AFFIRMING HORMONE THERAPY IN MANAGEMENT OF ADOLESCENT TRANSGENDER PATIENT

---

It is recommended to start hormone therapy once the adolescent reaches a level of competence to consent for treatment, which for many countries is the age of 16.<sup>3,60,61,62</sup> Defining a specific age is laden with challenges since for some individuals with severe dysphoria, the risk of withholding treatment until an older age outweighs the benefit, and similarly, there are others for whom treatment should be withheld until competency is reached. Prior to initiating treatment, the patient should be fully informed on the risks of the treatment and the expected outcomes.

Gender-affirming sex hormone induction is performed in a similar fashion as the treatment of hypogonadal patients. TG males will gradually initiate a testosterone regimen, while TG females will begin estrogen treatment in a gradually escalating dose schedule. There are many regimens that can be utilized to achieve the same goal of masculinizing a genetic female and feminizing a genetic male (Table 18.6). In general, hormone regimens should be started at a low dose and increased incrementally. This allows a provider to ensure there are no issues with tolerance or adverse side effects. The slow initiation of hormones also allows the individual to gradually adapt to the physical changes they will experience and provide time for social integration. Gonadal suppression with GnRHa is continued in order to suppress endogenous hormone production to ensure maximal benefit of gender-affirming regimens at the lowest dose. For TG females, the use of a GnRH analogue or an antiandrogen will need to be maintained until gonadectomy. For TG males, GnRHa can be discontinued once male testosterone levels are reached and suppression of the HPO axis has occurred.

Physical examination and laboratory monitoring is similar to the surveillance of the adult TG patients discussed earlier. As deemed medically necessary, visits may be more frequent or for greater duration given the slower titration and prolonged time to achieve stable adult dose on the hormones. Additionally, in the adolescent assessment of Tanner stage, height/weight should be done at every visit, while bone age and bone mineral density evaluation should be considered as indicated.<sup>3</sup>



# **SPECIAL CONSIDERATIONS**

---

# Fertility Preservation

For many individuals who have anticipated the initiation of hormone therapy to feel their authentic self, the thought of postponing treatment, even briefly, may not be acceptable. However, a discussion on fertility potential and fertility preservation is most optimal when undertaken before initiating any definitive intervention (medical or surgical). Studies have shown that 40–50% of TG individuals wish to have children.<sup>63,64,65</sup> Thus, it is imperative that prior to initiation of any gender-affirming hormone treatment, all individuals should be counseled on implications of exogenous hormone therapy on their fertility potential, and reproductive endocrinologists are uniquely positioned to play a critical role in optimizing care of TG patients. Information on the spectrum of available options and recommendations individualized to patient needs and preferences must be provided. The field of assisted reproductive technologies (ART) has expanded the options for TG men and women to have genetic offspring. Providers should be able to discuss the various methods available to achieve a family in the future including gamete (egg or sperm) and embryo cryopreservation, tissue (testicular or ovarian) cryopreservation, donor gamete options, gestational surrogacy, and adoption. If the primary medical provider does not feel competent to counsel an individual regarding fertility preservation options, the patient should be referred to reproductive endocrinologists for further guidance.

The ideal time to preserve gametes is prior to any hormone treatment. In TG males, testosterone treatment suppresses the HPO axis, whereby it inhibits ovulation and results in amenorrhea. Upon cessation of testosterone use, most TG males have a return of menses within 6 months.<sup>66</sup> It should be noted that although most will resume menstruation, in some cases the amenorrhea is irreversible. Numerous pregnancies have resulted in TG males who have stopped gender-affirming hormone treatment and either conceived spontaneously with a partner, used donor sperm insemination, or relied on assisted reproductive technology to successfully conceive. If oocyte or embryo cryopreservation is desired, the TG male will undergo controlled ovarian hyperstimulation with subsequent oocyte retrieval. The mature oocytes retrieved can be cryopreserved until further use or can be fertilized to create embryos when a partner or donor sperm source is available. For those who have already initiated testosterone treatment, it will need to be discontinued; ART can then be offered once hormone parameters have returned to normal female levels. Long-term testosterone exposure on oocyte quality is uncertain; however, normal pregnancies have been reported.<sup>67</sup>

It is not uncommon for TG individuals to have an aversion to their misaligned reproductive organs. Fertility preservation-related consideration must be discussed when definitive surgery (hysterectomy or oophorectomy by TG male and orchiectomy by TG female) is desired. Cryopreservation of the ovarian cortex or of testicular

extracted sperm can be planned at the time of definitive surgery; individuals seeking ovarian tissue cryopreservation to retain fertility potential must be advised that the procedure is still considered experimental. Similarly, if a hysterectomy is desired, a need for gestational surrogate to achieve future pregnancy with biologic gametes must be clarified.

If reproductive organs are preserved, TG males can become pregnant and successfully deliver.<sup>66</sup> For some TG males, pregnancy is not only a means to have a family but is also a highly desired experience. Once pregnancy is attained, regular prenatal care should be ensured with particular attention to the challenges that may arise given the psychological and physical changes in TG males.

For TG females, estrogen and antiandrogen hormones suppress gonadotropin levels resulting in impaired testosterone production. Testosterone is necessary for normal spermatogenesis; therefore, spermatozoa count and motility are significantly affected.<sup>67,68</sup> If hormones are discontinued, spermatogenesis will likely resume when hormones return to normal male levels (this can take a few months and not always reversible). Many TG females are hesitant to discontinue gender-affirming hormones for the duration of time needed to reestablish normal testosterone levels and for spermatogenesis to resume. Elective sperm cryopreservation should be considered prior to hormone treatment or gonadectomy. Depending on the quality and quantity of spermatozoa cryopreserved, it may be best to recommend in vitro fertilization with intracytoplasmic sperm injection (ICSI) instead of an intrauterine insemination.<sup>69</sup> For those who have azoospermia or significantly impaired sperm parameters following hormone cessation, surgical sperm extraction (testicular sperm extraction) may warrant consideration.

For those TG individuals who do not wish to discontinue hormone treatment or whose infertility is irreversible given medical or surgical alterations, the use of donor gametes may be an option to attain parenthood. For others, adoption may be the preferred choice to complete their family.

# Contraception

Gender-affirming hormone therapy alone is not a reliable form of contraception. Furthermore, testosterone during pregnancy, particularly during early embryogenesis, is a teratogen, as are antiandrogens. Contraception is a topic that providers must address with TG individuals. A candid discussion on sexual practices and exogenous hormone exposure should be an integral component of TG care.

Sexual orientation, sexual practices, and individual preference all are relevant when identifying a contraceptive method best suited for an individual. Reproductive age TG males and females, who are not on gender-affirming hormones and in a heterosexual sexual relationship, should use contraception if pregnancy is not desired. For TG males not on gender-affirming hormones, any of the various established methods of contraception to include combined hormonal pills, patches or ring, progestin-only pills, intradermal progestin implants, or hormonal or nonhormonal intrauterine devices can be recommended. The use of levonorgestrel intrauterine device (IUD) may be an attractive option given that it serves the purpose of contraception and often results in a cessation of menses, without the concern of taking an estrogen-based medication. Alternatively, TG males, who are on gender-affirming hormones and in a relationship with a cisgender male, may desire nonhormonal contraceptive options. For these individuals the copper IUD or barrier contraceptive methods may be preferred.<sup>70</sup>

A sexually active TG female in a sexual relationship with a cisgender female partner should use barrier contraceptive measures if pregnancy is not desired. It should be noted that although spermatogenesis is likely compromised with estrogen therapy, TG females may not achieve complete azoospermia. Alternatively, the cisgender partner can use a reliable hormonal or nonhormonal contraceptive method that is currently available. Both TG males and females, particularly those engaging in high-risk sexual behaviors, should be counseled on concomitant use of barrier contraceptive measures for prevention of sexually transmitted infections.

**HEALTH** **SCREENING**  
**RECOMMENDATIONS FOR TRANSGENDER**  
**HEALTH AND WELLNESS**

---

# Breast Screening

It is not uncommon for TG individuals to avoid or minimize care for their natal sex organs. Primary care providers should ensure to follow established screening guidelines while the TG person still has the natal organ or tissue. Transgender males, who have not undergone bilateral mastectomy, should have a screening mammogram performed per current guidelines.<sup>71,72</sup> It should be noted that TG males have a lower rate of breast cancer when compared to cisgender individuals. The reduction is likely attributable to the high rate of mastectomies in these patients, as well as the changes in breast tissue seen with testosterone treatment. Testosterone decreases the glandular breast tissue and increases the amount of fibrous connective tissue.<sup>42,73</sup> No reliable recommendation exists on how to screen TG males who have undergone bilateral mastectomy. Most breast tissue is removed during the procedure; however, residual tissue can always remain. One option is to perform annual chest wall physical examinations, although no data exists to support this approach.<sup>43</sup> If a mass is palpated by the patient or provider, imaging with an ultrasound or magnetic resonance imaging (MRI) should be ordered to further evaluate the concerning area.

There are no current guidelines on how to screen TG females for breast cancer. The use of estrogen hormones increases the breast tissue density of TG females, although typically these individuals have less years of estrogen exposure when compared to cisgender females.<sup>43,74</sup> In a retrospective study of 2,307 TG females treated at a single Dutch center, the incidence of breast cancer was 4.1/100,000 person-years, in comparison to 150/100,000 person-years in the cisgender group.<sup>75</sup> Additionally, supporting the notion that estrogen alone does not increase breast cancer risk, the Women's Health Initiative study reported no increased risk of breast cancer in the group using conjugated equine estrogen alone when compared to placebo.<sup>76</sup>

Although there are no clear guidelines on when, or if, TG females should have breast cancer screening, it is reasonable to individualize recommendations based on the duration of estrogen use. The University of California San Francisco Center of Excellence for Transgender Health recommends starting screening mammograms once the age of 50 and 5–10 years of feminizing hormone use has been reached.<sup>43</sup>

# Cervical Screening

Transgender males who have not had gender-affirming surgery should have a Papanicolaou (Pap) smear with or without human papilloma virus testing beginning at age 21 as per American Society for Colposcopy and Cervical Pathology (ASCCP) guidelines.<sup>77</sup> Since there are limited data on cervical cancer rates within this population, the standard ASCCP guidelines that apply for cisgender females should be followed.<sup>78</sup> Every attempt should be made to have the Pap smear done in a gender-neutral clinic to limit the distress of going to the gynecologist or women's health clinic. If a hysterectomy is performed and all previous Pap smears have been normal, no further cervical screening is indicated.<sup>77</sup> It should be noted that TG women who have a neovagina do not need routine Pap smears. Examination of the neovagina should be performed to ensure normal integrity and to assess for any pathology, such as HPV condyloma formation.<sup>32</sup>

# Prostate Screening

Transgender females, even individuals who have undergone gender-affirming surgery, should continue to be screened for prostate cancer since cases have been reported even after gonadectomy.<sup>79</sup> Although TG females have lower circulating testosterone levels when estrogen and antiandrogens are utilized, there still remains the possibility of developing prostate cancer. As per American Cancer Society guidelines, men at average risk for prostate cancer should be offered screening at age 50.<sup>80</sup> Screening consists of a digital rectal examination and serum prostate-specific antigen (PSA). Transgender females who have had gender-affirming surgery may have prostates in different anatomic positions. For example, the prostate in TG females is typically located along the anterior vaginal wall.<sup>81</sup> A digital exam may need to be performed through the neovagina or rectum in order to palpate the prostate, and the examination should be performed by a provider who understands the anatomic changes following surgery.<sup>81</sup> Although PSA levels less than 2.5 ng/mL are desired in cisgender males, it is suggested that in the setting of prolonged estrogen exposure, PSA can be falsely low. Therefore, it is suggested that the PSA level in TG females should be lowered to less than 1.0 ng/mL or not used since it can be inaccurate.<sup>82</sup>



# GENDER REASSIGNING SURGERY

---

Many TG individuals never elect to pursue gender-affirming surgery, while for others surgery is deemed a medical necessity to complete their gender identity or alleviate their dysphoria. The different surgical options are often referred to as “top surgery” referring to augmentation mammoplasty or mastectomy, or “bottom surgery,” in reference to genital reassignment surgery.

Although not an explicit criterion, some organizations such as World Professional Association for Transgender Health (WPATH) recommend a second-independent assessment from a qualified health care provider prior to genital surgery.<sup>10</sup> Furthermore, prior to genital surgery, it is highly recommended that for at least 1 year, the individual has been on gender-affirming hormone treatment and living in their desired gender.<sup>10</sup> Due to the permanent nature of genital surgery and the high morbidity associated with these procedures, the patient should be extensively counseled and be of legal age.

It is not uncommon for TG males to start the surgical transition with bilateral mastectomies given the relatively low morbidity associated with this procedure. Unlike TG females, TG males can have the mastectomy done at any point, regardless of whether or not they are on hormone therapy.

Genital surgery consists of a total hysterectomy and bilateral oophorectomy. Although TG males do not appear to be at increased risk of uterine, ovarian, or cervical pathologies, by undergoing a hysterectomy with bilateral oophorectomy, issues with uterine bleeding will be resolved, and concerns regarding carcinoma in those tissues will lessen. Procedures such as metoidioplasty, phalloplasty, scrotoplasty, and vaginectomy with implantation of testicular prosthesis allow attainment of male anatomic structures. In approximately 5% of TG males, the clitoral enlargement following testosterone treatment is adequate to serve as a phallus.<sup>83</sup> Metoidioplasty and phalloplasty are alternative methods to create a phallus. Metoidioplasty, which is more commonly done, is a surgical procedure in which the clitoris is elongated to create a shaft, the urethra is lengthened so one can void from the shaft, and a scrotum is created from the existing genital tissue.<sup>15,32</sup> Phalloplasty is the creation of a phallus, typically using graft tissue from a donor site that is sensate, and has a directable urine stream for standing micturition. Penile prosthetics are often utilized for cosmesis and for the ability to have penetrative intercourse.<sup>15,84</sup> Unfortunately, many of the gender-affirming genital surgeries are fraught with a long postoperative hospital course, significant morbidity, and high complications rates and are exceptionally expensive. Phalloplasty with resultant aesthetic phallus is often performed in a multi-step fashion which may require several revisions and up to 1 year to accomplish.<sup>83,84</sup> Urethral complications are the most common and have been reported to be as high as 80%, whereas other

complications include skin necrosis/erosion, infection, hematoma formation, and wound dehiscence.<sup>85</sup>

Transgender females may elect to have augmentation mammoplasty in order to increase their breast size.<sup>86</sup> The use of estrogen therapy will increase breast tissue development in TG females. It is recommended that augmentation surgery not be performed until a minimum of 12 months of estrogen use.<sup>10</sup> This length of estrogen exposure allows for maximum breast tissue development and optimizes cosmetic outcome.<sup>10</sup> Over 50% of TG females find their breast size adequate after 2 years of estrogen use and do not seek further enhancement. Therefore it may warrant waiting until full breast tissue development prior to pursuing augmentation surgery.<sup>31,82</sup>

Genital surgery for TG females include penectomy, orchiectomy, vaginoplasty, clitoroplasty, and vulvoplasty. The simplest option is orchiectomy, which will eliminate endogenous testosterone production. This allows the patient to discontinue the use of any antiandrogen and may allow for lower estradiol doses.<sup>15</sup> Genital surgery involves surgical removal of the penis and testicles, with creation of a neovagina and reconstruction of the urethral meatus and sensate clitoris.<sup>32</sup> The neovagina can be lined using penile and sometimes scrotal skin, nongenital skin flaps, or colonic grafts. While skin grafts and penile inversion procedures are the most commonly used, colonic flaps have been taken from the cecum and rectosigmoid to create a neovagina that has natural lubrication.<sup>32,83,86,87</sup> Regular use of a vaginal dilator or vaginal intercourse is needed in order to maintain the neovagina functional. Vaginal stenosis tends to be the most common complication (12%) seen with neovagina formation; however, other complications such as skin necrosis/erosion, infection, rectovaginal fistula formation, and genital pain can be seen.<sup>88</sup>

In addition to the definitive surgical approaches discussed above, a number of aesthetic interventions can help create more feminine (i.e., facial feminization surgery, permanent hair removal, thyroid cartilage reduction) or masculine features (i.e., pectoral implants) per the individual's desire and discretion and provider's judgment and expertise.<sup>10</sup>

# SUMMARY

---

Due to improving societal understanding, increasing social acceptability, and better health care access, the number of TG individuals seeking medical care has been steadily increasing. It is imperative that health care providers become familiar with the special medical needs of this group to ensure that safe and appropriate treatment is provided. In efforts to achieve this goal, a multidisciplinary team is critical to assure that all aspects of care are addressed by those most skilled in the discipline. Appropriately designed prospective studies in TG health are clearly needed to better understand the mechanisms underlying gender dysphoria and the long-term effects of gender-affirming hormone therapy as well as to optimize surgical techniques to minimize the surgical morbidity of currently utilized interventions. The field must continue to evolve with the goal that TG individuals have access to options that will allow them to achieve their maximal potential as healthy members of their community.

# REFERENCES

1. **Tyldesley JA**, Hatchepsut: The Female Pharaoh, Penguins Group, London, 1996, pp. 99–129.
2. **Benjamin H**, The transsexual phenomenon, *Trans N Y Acad Sci* 29(4):428, 1967.
3. **Hembree WC, Cohen-Kettenis PT, Gooren L, Hannema SE, Meyer WJ, Murad MH, Rosenthal SM, Safer JD, Tangpricha V, T'Sjoen GG**, Endocrine treatment of gender-dysphoric/gender-incongruent persons: an Endocrine Society Clinical Practice guideline, *J Clin Endocrinol Metab* 102(11):1, 2017.
4. **David KG, Dingemans E, Freud JL**, On crystalline male hormone from testicles (testosterone) effective as from urine or from cholesterol, *Hoppe-Seyler's Z Physiol Chem* 233(5–6):261, 1935 (in German) Translated.
5. **Freeman ER, Bloom DA, McGuire EJ**, A brief history of testosterone, *J Urol* 165(2):371, 2001.
6. **Dodds EC, Goldberg L, Lawson W, Robinson R**, Estrogenic activity of certain synthetic compounds, *Nature* 141(3562):247, 1938.
7. **Magnus H**, Chirurgische Eingriffe bei Anomalien des Sexuallebens, *Therap Ggw* 67:451, 1933.
8. **Grant JM, Mottet LA, Tanis J, With DM, Henman JL, Harrison J**, et al., National transgender discrimination survey report on health and healthcare: findings of a study by the National Center for Transgender Equality and National Gay and Lesbian Task Force, 2010. [http://www.thetaskforce.org/static\\_html/downloads/resources\\_and\\_tools/ntds\\_reort\\_on\\_health.pdf](http://www.thetaskforce.org/static_html/downloads/resources_and_tools/ntds_reort_on_health.pdf) (Accessed March 18, 2018).
9. **Puckett JA, Cleary P, Rossman K, Newcomb ME, Mustanski B**, Barriers to gender-affirming care of transgender and gender nonconforming individuals, *Sex Res Social Policy* 15(1):48, 2018.
10. **World Professional Association for Transgender Health**, Standards of care for the health of transsexual, transgender, and gender nonconforming people. [http://www.wpath.org/site\\_page.cfm?pk\\_association\\_webpage\\_menu=1351&pk\\_association\\_webpage=3926](http://www.wpath.org/site_page.cfm?pk_association_webpage_menu=1351&pk_association_webpage=3926) (Accessed March 14, 2018).
11. **Lee PA, Houk CP, Ahmed SF, Hughes IA**, Consensus statement on management of intersex disorders, *Pediatrics* 118(2):488, 2006.
12. **Flores AR, Herman JL, Gates GJ, Brown TNT**, How Many Adults Identify as Transgender in the United States, The Williams Institute, UCLA School of Law, 2016. <https://williamsinstitute.law.ucla.edu/wp-content/uploads/How-Many-Adults-Identify-as-Transgender-in-the-United-States.pdf>
13. **Van Kesteren PJ, Gooran LJ, Megens JA**, An epidemiologic and demographic study of transsexuals in the Netherlands, *Arch Sex Behav* 25:589, 1996.
14. **DeCuypere G, Van Hemelrijck M, Michel A, Crael B, Heylens G, Rubens R, Hoebeke H, Monstrey S**, Prevalence and demography of transsexualism in Belgium, *Eur Psychol* 22(3):137, 2007.
15. **Chapkin SR, Kim F**, Ten most important things to know about caring for transgender patients, *Am J Med* 130:1238, 2017.
16. **American Psychiatric Association**, Diagnostic and statistic manual of mental disorders: DSM-IV- TR. Washington, DC, 2000.
17. **Cohen-Kettenis PT**, Gender change in 46, XY persons with 5 $\alpha$ -reductase-2 deficiency and 17 $\beta$ -hydrozosteroid dehydrogenase-3 deficiency, *Arch Sex Behav* 34(4):399, 2005.
18. **Barenbaum SA**, Effects of early androgen on sex-typed activities and interests in adolescents with congenital adrenal hyperplasia, *Horm Behav* 35:102, 1999.
19. **Ediati A, Juniarto AZ, Birnie E, Drop SLS, Faradz SMH, Dessens AB**, Gender development in Indonesian children, adolescents, and adults with disorders of sex development, *Arch Sex Behav* 44(5):1339, 2015.
20. **Dessens AB, Slijper FME, Drop SLS**, Gender dysphoria and gender change in chromosomal females with congenital adrenal hyperplasia, *Arch Sex Behav* 34(4):389, 2005.
21. **Gangaher A, Jyostna VP, Chauhan V, Hohn J, Mehta M**, Gender of rearing and psychosocial aspect of 46 XX congenital adrenal hyperplasia, *Ind J Endocrin Metab* 20(6):870, 2016.
22. **Reiner WG, Gearhart JP**, Discordant sexual identity in some genetic males with cloacal exstrophy assigned to female sex at birth, *N Engl J Med* 350:333, 2004.

23. **Gooren L**, The biology of human psychosexual differentiation, *Horm Behav* 50(4):589, 2006.
24. **Chung WCJ, De Vries GJ, Swaab D**, Sexual differentiation of the bed nucleus of the stria terminalis in humans may extend into adulthood, *J Neurosci* 22(3):1027, 2002.
25. **Swaab DF, Fliers E**, A sexually dimorphic nucleus in the human brain, *Science* 228:1112, 1985.
26. **Cooke BM, Hegstrom CD, Villeneuve LS, Breedlove SM**, Sexual differentiation of the vertebrate brain: principles and mechanisms, *Front Neuroendocrinol* 19:323, 1998.
27. **Zhou JN, Hofman MA, Gooren LJG, Swaab DF**, A sex difference in the human brain and its relation to transsexuality, *Nature* 378:68, 1995.
28. **Kruijver FP, Zhou JN, Pool CW, Hofman MA, Gooren LJG, Swaab DF**, Male-to-female transsexuals have female neuron numbers in a limbic nucleus, *J Clin Endocrinol Metab* 85(5):2034, 2000.
29. **Coolidge FL, Thede LL, Young SE**, The heritability of gender identity disorder in a child and adolescent twin sample, *Behav Genet* 32(4):251, 2002.
30. **Heylens G, De Cuypere G, Zucker KJ, Schelfaut C, Elaut E, Vanden Bossche H, De Baere E, T'Sjoen G**, Gender identity disorder in twins: a review of the case report literature, *J Sex Med* 9(3):751, 2012.
31. **Gómez-Gil E, Trilla-García A, Godás-Sieso T, Halperin-Rabinovich I, Puig Domingo M, Vidal Hagemeyer A, Peri Nogués JM**, Estimación de la prevalencia, incidencia y razón de sexos del transexualismo en Cataluña según la demanda asistencial [Estimation of prevalence, incidence and sex ratio of transsexualism in Catalonia according to health care demand]. *Actas Esp Psiquiatr* 34:295, 2006.
32. **Unger CA**, Care of the transgender patient: the role of the gynecologist, *Obstet Gynecol* 211(1):16, 2014.
33. **Owen-Smith AA, Sineath C, Sanchez T, Dea R, Giammettei S, Gillespie T, Helms MF, Hunkeler EM, Quinn VP, Roblin D, Slovis J, Stephenson R, Sullivan PS, Tangpricha V, Woodyatt C, Goodman M**, Perception of community tolerance and prevalence of depression among transgender persons, *J Gay Lesbian Ment Health* 21(1):64, 2017.
34. **Su D, Irwin JA, Fischer C, Ramos A, Kelley M, Mendoza DAR, Coleman JD**, Mental health disparities within the LGBT population: a comparison between transgender and nontransgender individuals, *Transgend Health* 1(1):12, 2016.
35. **Haas AP, Rodgers PL, Herman JL**, Suicide Attempts among Transgender and Gender Nonconforming Adults, The Williams Institute, UCLA Law School, 2014, <https://williamsinstitute.law.ucla.edu/wp-content/uploads/AFSP-Williams-Suicide-Report-Final.pdf>
36. **American Psychiatric Association**, Diagnostic and Statistical Manual of Mental Disorders, 5th ed., American Psychiatric Association Publishing, Arlington, 2013.
37. **World Health Organization**, International Statistical Classification of Diseases and Related Health Problems, 10th Revision, WHO Publishing, Geneva, 2011.
38. **Gómez-Gil E, Zubiaurre-Elorza L, Esteva I, Guillamon A, Godás T, Cruz Almaraz M, Halperin I, Salamero M**, Hormone-treated transsexuals report less social distress, anxiety and depression, *Psychoneuroendocrinology* 37(5):662, 2012.
39. **Gorin-Lazard A, Baumstarck K, Boyer L, Maquigneau A, Gebleuz S, Penochet J**, Hormonal therapy is associated with better self-esteem, mood, and quality of life in transsexuals, *J Nerv Ment Dis* 201(11):996, 2013.
40. **Colizzi M, Costa R, Todarello O**, Transsexual patients' psychiatric comorbidity and positive effect of cross-sex hormonal treatment on mental health: results from a longitudinal study, *Psychoneuroendocrinology* 39:65, 2014.
41. **Murad MH, Elmin MB, Garcia MZ, Mullan RJ, Murad A, Erwin PJ, Montori VM**, Hormonal therapy and sex reassignment: a systematic review and meta-analysis of quality of life and psychosocial outcomes, *Clin Endocrinol* 72:214, 2010.
42. **Irwig M**, Testosterone therapy for transgender men, *Lancet Diabetes Endocrinol* 5(4):301, 2017.
43. **Deutsch MB**, Overview of feminizing hormone therapy, In: Madeline B Deutsch, ed., *Guidelines for the Primary and Gender-Affirming Care of Transgender and Gender Nonbinary People*, 2nd ed., Center of Excellence for Transgender Health, Department of Family and Community Medicine, University of California San Francisco, 2016. [www.transhealth.ucsf.edu/guidelines](http://www.transhealth.ucsf.edu/guidelines) (Accessed March 8, 2018).

44. **Ahmad S, Leinung M**, The response of the menstrual cycle to initiation of hormone therapy in transgender men, *Transgend Health* 2(1):176, 2017.
45. **Deutsch MB, Bhakri V, Kubicek K**, Effects of cross-sex hormone treatment on transgender women and men, *Obstet Gynecol* 125:605, 2015.
46. **Nakamura A, Watanabe M, Sugimoto M, Sako T, Mahmood S, Kaku M, Nasu Y, Ishii K, Nagai A, Kumon H**, Dose-response analysis of testosterone replacement therapy in patients with female to male gender identity disorder, *Endocr J* 60:275, 2013.
47. **Velho I, Figuera TM, Ziegelmann PK, Spritzer PM**, Effects of testosterone therapy on BMI, blood pressure and laboratory profile of transgender men: a systematic review, *Andrology* 5:881, 2017.
48. **Wierckx K, Van Caenegem E, Schreiner T, Haraldsen I, Fisher A, Toye K, Kaufman JM, T'Sjoen G**, Cross-sex hormone therapy in trans person is safe and effective at short-time follow-up: results from European Network for the Investigation of Gender incongruence, *J Sex Med* 11(8):1999, 2014.
49. **Elamin MB, Garcia MZ, Murad MH, Erwin PJ, Montori VM**, Effect of sex steroid use on cardiovascular risk in transsexual individuals: a systematic review and meta-analysis, *Clin Endocrinol* 71(1):1, 2010.
50. **Weinand JD, Safer JD**, Hormone therapy in transgender adults is safe with provider supervision: a review of hormone therapy sequelae for transgender individuals, *J Clin Transl Endocrinol* 2:55, 2015.
51. **Shatzel JJ, Connelly KJ, DeLoughery TG**, Thrombotic Issues in transgender medicine: a review, *Am J Hematol* 92(2):204, 2016.
52. **Lehrman K**, Pulmonary embolism in a transsexual man taking diethylstilbestrol, *JAMA* 235(2):532, 1976.
53. **Asscheman H, Tsjoen G, Lemaire A, Mas M, Meriggiola M, Mueller A, Kuhn A, Dhejne C, Morel-Journel N, Gooren LJ**, Venous thrombo-embolism as a complication of cross-sex hormone treatment of male-to-female transsexual subjects: a review, *Andrologia* 46(7):791, 2013.
54. **Wierckx K, Elaut E, Declercq E, Heylens G, De Cuypere G, Taes Y, Kaufman JM, T'Sjoen G**, Prevalence of cardiovascular disease and cancer during cross-sex hormone therapy in a large cohort of trans persons: a case-control study, *Eur J Endocrinol* 169(4):471, 2013.
55. **Wierckx K, Mueller S, Weyers S, Van Caenegem E, Roef G, Heylens G, T'Sjoen G**, Long-term evaluation of cross-sex hormone treatment in transsexual persons, *J Sex Med* 9(10):2641, 2012.
56. **Drummond KD, Bradley SJ, Peterson-Badali M, Zucker KJ**, A follow-up study of girls with gender identity disorder, *Dev Psychol* 44(1):34, 2008.
57. **Wallien MSC, Swaab H, Cohen-Kettenis PT**, Psychiatric comorbidity among children with gender identity disorder, *J Am Acad Child Adolesc Psychiatry* 46(10):1307, 2007.
58. **Lynch MM, Khandheria MM, Meyer WJ**, Retrospective study of the management of childhood and adolescent gender identity disorder using medroxyprogesterone acetate, *Int J Transgenderism* 16:201, 2015.
59. **Paulson RJ**, At last, an orally active gonadotropin-releasing hormone antagonist, *Fertil Steril* 111(1):30-31, 2019. doi: 10.1016/j.fertnstert.2018.11.024. No abstract available. PMID: 30611410
60. **de Vries ALC, Steensma TD, Doreleijers TAH, Cohen-Kettenis PT**, Puberty suppression in adolescents with gender identity disorder: a prospective follow-up study, *J Sex Med* 8(8):2276, 2011.
61. **Mann L, Harmoni R, Power C**, Adolescent decision-making: the development of competence, *J Adolesc* 12(3):265, 1989.
62. **Stultiens L, Goddin T, Borry P, Dierickx K, Nys H**, Minors and informed consent: a comparative approach, *Eur J Health Law* 14(1):21, 2007.
63. **Goldman RH, Kaser DJ, Missmer SA, Farland LV, Scout, Ashby RK, Ginsberg ES**, Fertility treatment for the transgender community: a public opinion study, *J Assist Reprod Genet* 34:1457, 2017.
64. **Wierckx K, Van Caenegem E, Pennings G, Elaut E, Dedecker D, Van De Peer F, Weyers S, De Sutter P, T'Sjoen G**, Reproductive wish in transsexual men, *Hum Reprod* 27(2):483, 2012.
65. **De Sutter P, Kira K, Verschoor A, Hotimsky A**, The desire to have children and the preservation of fertility in transsexual women: a survey, *Int J Transgenderism* 6(3):215, 2002.
66. **Light AD, Obedin-Maliver J, Sevelius JM, Kerns JL**, Transgender men who experience pregnancy after female-to-male gender transitioning, *Obstet Gynecol* 124(6):1120, 2014.
67. **Maxwell S, Noyes N, Keefe D, Berkeley AS, Goldman KN**, Pregnancy outcomes after fertility

- preservation in transgender men, *Obstet Gynecol* 129(6):1031, 2017.
68. **Schneider F, Kliesch S, Shlatt S, Neuhaus N**, Andrology of male-to-female transsexuals: influence of cross-sex hormone therapy on testicular function, *Andrology* 5(5):873, 2017.
  69. **Hamada A, Kingsberg S, Wierckx K, T'Sjoen G, De Sutter P, Knudson G, Agarwal A**, Semen characteristics of transwomen referred for sperm banking before sex transition: a case series, *Andrologia* 47(7):832, 2015.
  70. **Bentsianov S, Gordon L, Goldman A, Jacobs A, Steever J**, Use of copper intrauterine device in transgender male adolescents, *Contraception* 98(1):74, 2018.
  71. **American College of Obstetricians-Gynecologists**, Practice bulletin no. 122: breast cancer screening, *Obstet Gynecol* 118(2 Pt 1):372, 2011.
  72. **Siu AL; U.S. Preventative Services Task Force**, Screening for breast cancer: U.S. Preventative Services Task Force Recommendation Statement, *Ann Intern Med* 164(4):279, 2016.
  73. **Gynberg M, Fanchin R, Dubost G, Colau JC, Bremont-Weil C, Frydman R, Ayoubi JM**, Histology of genital tract and breast tissue after long-term testosterone administration in a female-to-male transsexual population, *Reprod Biomed Online* 20:553, 2010.
  74. **Weyers S, Villeirs G, Vanherreweghe E, Verstraelen H, Monstrey S, Van den Broecke R, Gerris J**, Mammography and breast sonography in transsexual women, *Eur J Radiol* 74(3):508, 2010.
  75. **Gooren LJ, van Trotsenburg MAA, Giltay EJ, van Diest PJ**, Breast cancer development in transsexual subjects receiving cross-sex hormone treatment, *J Sex Med* 10(12):3129, 2013.
  76. **Anderson GL, Limacher M, Assaf AR, Bassford T, Beresford SA, Black H, Bonds D, Brunner R, Brzyski R, Caan B, Chlebowski R, Curb D, Gass M, Hays J, Heiss G, Hendrix S, Howard BV, Hsia J, Hubbell A, Jackson R, Johnson KC, Judd H, Kotchen JM, Kuller L, LaCroix AZ, Lane D, Langer RD, Lasser N, Lewis CE, Manson J, Margolis K, Ockene J, O'Sullivan MJ, Phillips L, Prentice RL, Ritenbaugh C, Robbins J, Rossouw JE, Sarto G, Stefanick ML, Van Horn L, Wactawski-Wende J, Wallace R, Wassertheil-Smoller S; Women's Health Initiative Steering Committee**, Effects of conjugated equine estrogen in postmenopausal women with hysterectomy: the Women's Health Initiative randomized controlled trial, *JAMA* 291(14):1701, 2004.
  77. **Saslow D, Solomon D, Lawson HW, Killackey M, Kulasingam SL, Cain J, Garcia FA, Moriarty AT, Waxman AG, Wilbur DC, Wentzensen N, Downs LS Jr, Spitzer M, Moscicki AB, Franco EL, Stoler MH, Schiffman M, Castle PE, Myers ER, Chelmow D, Herzig A, Kim JJ, Kinney W, Herschel WL, Waldman J**, American Cancer Society, American Society for Colposcopy and Cervical Pathology and American Society for Clinical Pathology screening guidelines for the prevention and early detection of cervical cancer, *J Low Genit Tract Dis* 16(3):175, 2012.
  78. **Irwig M**, Clinical dilemmas in the management of transgender men, *Curr Opin* 24(3):233, 2017.
  79. **Miksad RA, Bublely G, Church P, Sanda M, Rofsky N, Kaplan I, Cooper A**, Prostate cancer in a transgender woman 41 years after initiation of feminization, *JAMA* 296(19):2316, 2006.
  80. **Wolf AM, Wender RC, Etzioni RB, Thompson IM, D'Amico AV, Volk RJ, Brooks DD, Dash C, Guessous I, Andrews K, DeSantis C, Smith RA; American Cancer Society Prostate Cancer Advisory Committee**, American Cancer Society guidelines for the early detection of prostate cancer: update 2010, *CA Cancer J Clin* 60(2):70, 2010.
  81. **Weyers S, De Sutter P, Hoebeke S, Monstrey G, T'Sjoen G, Verstraelen H, Gerris J**, Gynaecological aspects of the treatment and follow-up of transsexual men and women, *Facts Views Vis Obgyn* 2(1):35, 2010.
  82. **Trum HW, Hoebeke P, Gooren LJ**, Sex reassignment of transsexual people from a gynecologist's and urologist's perspective, *Acta Obstet Gynecol Scand* 94(6):563, 2015.
  83. **Gooren L**, Hormone treatment of the adult transsexual patient, *Horm Res* 64:31, 2005.
  84. **Morrison SD, Shakir A, Vyas KS, Kirby J, Crane CN, Lee GK**, Paloplasty: a review of technique and outcomes, *Plast Reconstr Surg* 138(3):594, 2016.
  85. **Morrison SD, Chen ML, Crane CN**, An overview of female-to-male gender-confirming surgery, *Nat Rev Urol* 14(8):486, 2017.
  86. **Lista F, Ahmad J**, Evidence-based medicine: augmentation mammoplasty, *Plast Reconstr Surg* 132(6):1684,

2013.

87. **Bizic MR, Stojanovic V, Djordjevic ML**, Genital reconstruction for the transgendered individual, *J Pediatr Urol* 13(5):446, 2017.
88. **Horbach SER, Bouman M, Smit JM, Ozer M, Buncamper ME, Mullender MG**, Outcome of vaginoplasty in male-to-female transgenders: a systematic review of surgical techniques, *J Sex Med* 12:1499, 2015.



# Obesity

Because approximately 40% of American adults are obese, the unrewarding fight against obesity is all too common, not only with our patients but also with ourselves. An astonishing 66.2% of U.S. women were overweight or obese (28.1% overweight and 38.1% obese) in 2014.<sup>1,2,3,4,5,6</sup> Unfortunately, for over 100 years, the incidence of obesity has been increasing in the United States and Europe, a reflection of an affluent society with an increasingly sedentary life combined with high caloric foods, but most of the increase has been recent, beginning in 1980.<sup>7,8,9,10</sup> About 75% of American adults do zero vigorous physical activity in their leisure time.<sup>11</sup> This change in lifestyle has produced a high prevalence of obesity with a similar trajectory in adults and children; almost 17% of school-aged children and adolescents in 2008 were obese and 32% overweight.<sup>11,12</sup>

The lack of success in treating obesity is not due to an unawareness of the implications of obesity; there is a clear-cut, well-recognized relationship between mortality and weight.<sup>1</sup> The death rate from diabetes mellitus, for example, is approximately 4 times higher among obese diabetics than among those who control their weight. The death rate from appendicitis is double, presumably from anesthetic and surgical complications. The increase in mortality is not limited to obesity; all overweight individuals have an increase in the risk of death.<sup>13</sup> The Nurses' Health Study estimated that 23% of all deaths in nonsmoking middle-aged women are attributable to being overweight.<sup>14</sup>

The incidence of hypertension, heart disease, type 2 diabetes mellitus, metabolic syndrome, gout, gallbladder disease, obstructive sleep apnea, osteoarthritis, and all the most prevalent cancers, including colorectal cancer, endometrial cancer, and postmenopausal breast cancer, is elevated in overweight people.<sup>1,15,16,17</sup> Being overweight in adolescence is even a more powerful predictor of cardiovascular adverse health effects than being overweight as an adult.<sup>18</sup>

The increasing prevalence of obesity and its consequences now threaten to replace smoking as the primary cause of preventive mortality. A 40-year-old woman who is a nonsmoker can expect to lose 3.3 years of life if she is overweight (not obese, just overweight)!<sup>19</sup> If obese, the loss is 7.1 years, and if smoking is added, the loss is 13.3 years. Unless there is a major change, it is estimated that the rise in U.S. life expectancy

experienced over the last several decades will substantially slow down, offsetting the impact of declining smoking.<sup>20</sup>

When the personal and social problems encountered by obese people are also considered, it is no wonder that a clinician without a weight problem cannot comprehend why fat individuals remain overweight. The frequency with which a practitioner encounters the obese patient whose weight does not decrease despite a sworn adherence to a limited-calorie diet makes one question if there is something physiologically different about this patient. Is the problem due to lack of discipline and cheating on a diet, or does it also involve a pathophysiologic factor? Is the physiology of obese people unusual, or are they simply gluttons? **Modern studies of obesity strongly indicate that this is a multifactorial problem and that lack of willpower and laziness is not the simple answer.**

# DEFINITION OF OBESITY

---

Obesity is an excess storage of triglycerides in adipose cells; an excess of body fat. There is a difference between obese and overweight.<sup>21</sup> Overweight is a body weight, including muscle, bone, fat, and body water, in excess of some standard or ideal weight. The ideal weight for any adult is believed to correspond to his or her ideal weight from age 20 to 30. The following formulas give ideal weights in pounds:

- **Women:**  $100 + (4 \times \{\text{height in inches minus } 60\})$
- **Men:**  $120 + (4 \times \{\text{height in inches minus } 60\})$

At a weight close to ideal weight, individuals may be overweight, without having excess fat. This is especially true of individuals engaged in regular exercise. An estimate of body fat, therefore, is more meaningful than a measurement of height and weight.

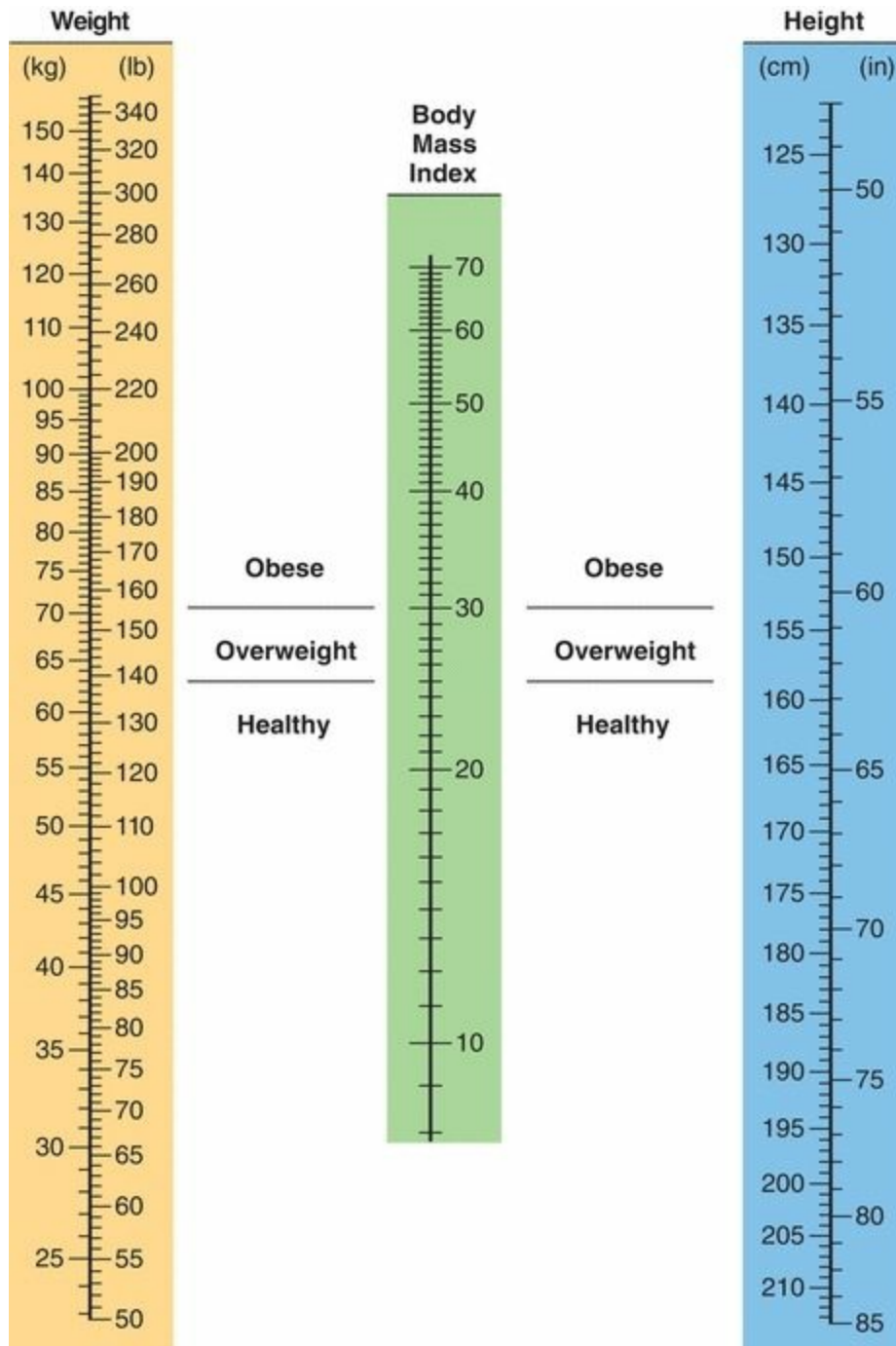
The most accurate method of determining body fat is to determine the density of the body by underwater measurement (hydrodensitometry). It certainly is not practical to measure density by submerging individuals in water in our offices; therefore, skinfold measurements with calipers have become popular as an index of body fat, or expensive imaging techniques can be utilized. These latter methods are not necessary for clinical practice. It is far simpler to utilize the body mass index (BMI) nomogram, a method that corresponds closely to densitometry measurements.<sup>22</sup>

**The body mass index (the Quetelet index) is the ratio of weight divided by the height squared (in metric units):**

$$\text{BMI} = \text{kilograms/meters}^2$$

To use the nomogram for BMI, read the central scale by aligning a straight edge between height and body weight. Overweight is defined as a BMI of 25 or more (66.2% of American women in 2014). Obesity is defined as a BMI of 30 or more (38.1% of American women in 2014). A “good” BMI for most middle-aged people is in the range of 20–24.<sup>23</sup> Mortality is lowest in middle-aged women with a BMI below 19.<sup>14,24</sup> A BMI in the overweight or obese range predicts an increased risk for earlier death, no matter the age of the patient.

- **Overweight:** BMI = 25–29.9
- **Obesity:** BMI = 30 and higher (Figure 19.1)



**FIGURE 19.1**

A person is obese when the amount of adipose tissue is sufficiently high (20% or more over ideal weight) to detrimentally alter biochemical and physiologic functions and to shorten life expectancy. Obesity is associated with four major risk factors for atherosclerosis: hypertension, diabetes, hypercholesterolemia, and hypertriglyceridemia. Overweight individuals have a higher prevalence of hypertension at every age, and the risk of developing hypertension is related to the amount of weight gain after age 25. The two in combination (hypertension and obesity) increase the risk

of heart disease, cerebrovascular disease, and death. The Nurses' Health Study documented a continuing correlation between the BMI and cardiovascular disease, diabetes, and cancer.<sup>14,25,26</sup> In other words, even a modest gain in adult weight, even in a range not considered to be overweight, increases the risk of cardiovascular and metabolic diseases. However, at any given BMI level, the presence of an increase in abdominal fat, metabolic risk factors, or a strong family history of diabetes, hypertension, and heart disease increases the risk to good health.

It is well documented that women have a greater prevalence of obesity compared with men. One reason may be the fact that women have a lower metabolic rate than men, even when adjusted for differences in body composition and level of activity.<sup>27</sup> Another reason that more women gain weight with age is the postmenopausal loss of the increase in metabolic rate that is associated with the luteal phase of the menstrual cycle. The difference between men and women is even greater in older age.

Unfortunately, the basal metabolic rate decreases with age.<sup>28,29</sup> After age 18, the resting metabolic rate declines about 2% per decade. The age-related decline in basal metabolic rate is not observed in women who continue to be involved in a regular endurance exercise program.<sup>30</sup> A 30-year-old individual will inevitably gain weight if there is no change in caloric intake or exercise level over the years. The middle-age spread is both a biologic and a psychosociologic phenomenon. It is, therefore, important for both our patients and ourselves to understand adipose tissue and the problem of obesity.

# PHYSIOLOGY OF ADIPOSE TISSUE

Adipose tissue serves three general functions:

1. Adipose tissue is a storehouse of energy.
2. Fat serves as a cushion from trauma.
3. Adipose tissue plays a role in the regulation of body heat ([Figure 19.2](#)).

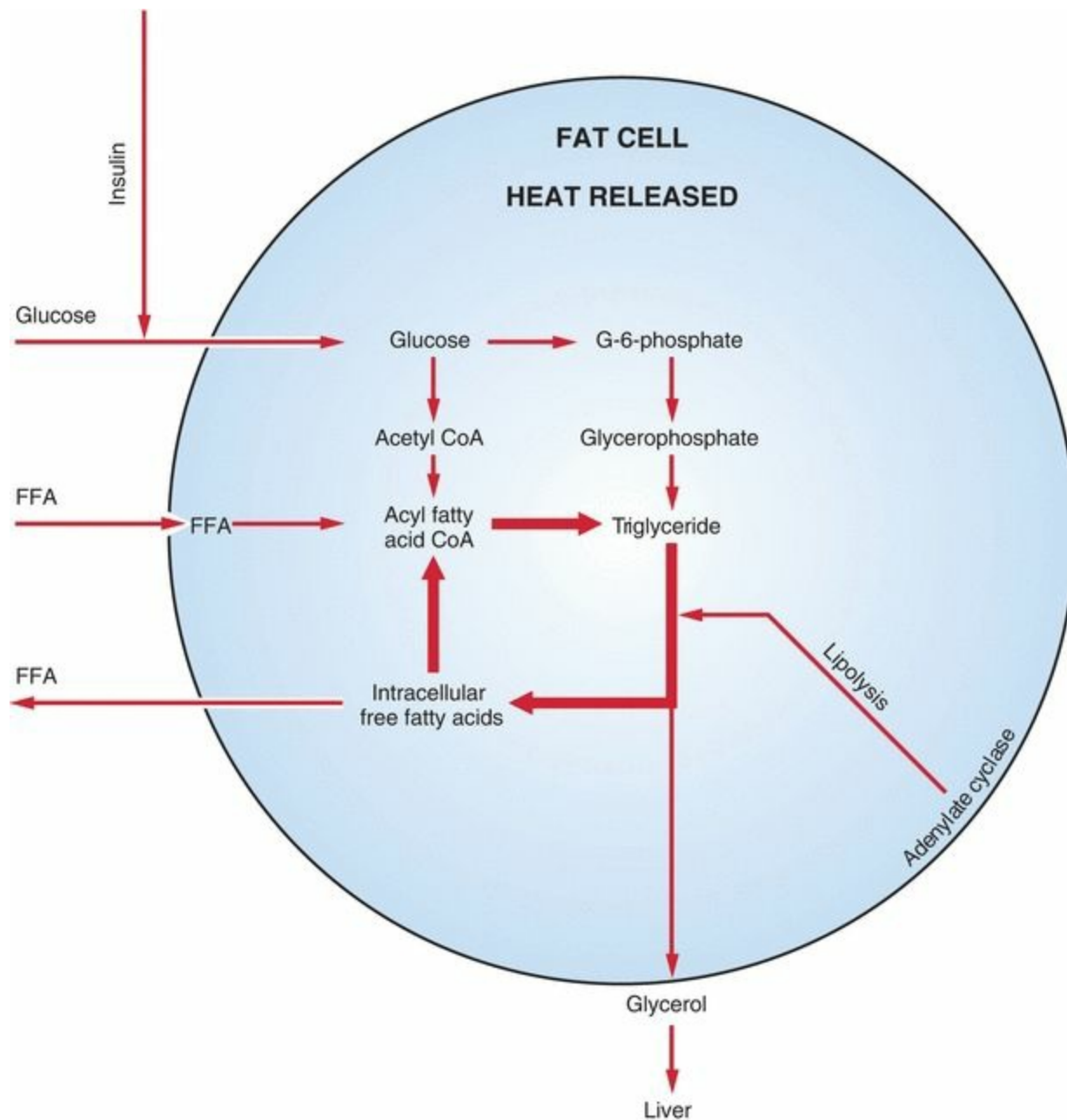
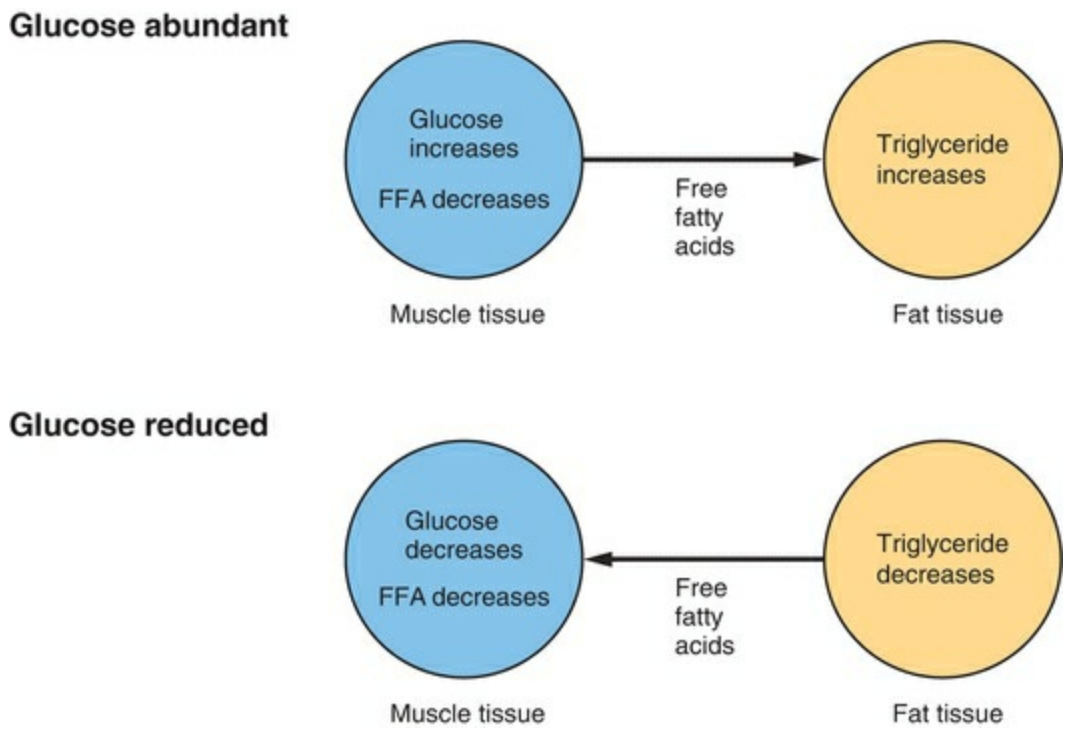


FIGURE 19.2

Each cell of adipose tissue can be regarded as a package of triglyceride, the most concentrated form of stored energy. There are 8 calories/g of triglyceride compared to 1 calorie/g of glycogen. The total store of tissue and fluid carbohydrate in adults (about 300 calories) is inadequate to meet between-meal demands. The storage of energy in fat tissue allows us to do other things besides eating. Our energy balance, therefore, is essentially equivalent to our fat balance. Thus, obesity is a consequence of the fat imbalance inherent in high-calorie diets.

The mechanism for mobilizing energy from fat involves various enzymes and neurohormonal agents. Following ingestion of fat and its breakdown by gastric and pancreatic lipases, absorption of long-chain triglycerides, and free fatty acids takes place in the small bowel. Chylomicrons (microscopic particles of fat) transferred through lymph channels into the systemic venous circulation are normally removed by hepatic parenchymal cells where a new lipoprotein is released into the circulation. When this lipoprotein is exposed to adipose tissue, lipolysis takes place through the action of lipoprotein lipase, an enzyme derived from the fat cells themselves. The fatty acids that are released then enter the fat cells where they are reesterified with glycerophosphate (glycerol-3-phosphate) into triglycerides. A triglyceride is an ester derivative derived from glycerol and three fatty acids; triglycerides are the main constituents of body fat in human and animals as well as vegetable fat. Because alcohol diverts fat from oxidation to storage, body weight is directly correlated with the level of alcohol consumption.<sup>31</sup>

**Glucose serves three important functions (Figure 19.3):**



## FIGURE 19.3

1. Glucose supplies carbon atoms in the form of acetyl coenzyme A (acetyl CoA).
2. Glucose provides hydrogen for reductive steps.
3. Glucose is the main source of glycerophosphate.

The production and availability of glycerophosphate (required for reesterification of fatty acids and their storage as triglycerides) are considered rate limiting in lipogenesis, and this process depends on the presence of glucose.

After esterification, subsequent lipolysis results in the release of fatty acids and glycerol. In the cycle of lipolysis and reesterification, energy is freed as heat. A low variable level of lipolysis takes place continuously; its basic function is to provide body heat.

The chief metabolic products produced from fat are the circulating free fatty acids. Their availability is controlled by adipose tissue cells. When carbohydrate is in short supply, a flood of free fatty acids can be released. The free fatty acids in the peripheral circulation are almost wholly derived from endogenous triglycerides that undergo rapid hydrolysis to yield free fatty acid and glycerol. The glycerol is returned to the liver for resynthesis of glycogen.

Free fatty acid release from adipose tissue is stimulated by physical exercise, fasting, exposure to cold, nervous tension, and anxiety. The release of fatty acids by lipolysis varies from one anatomic site to another. Omental, mesenteric, and subcutaneous fat is more labile and easily mobilized than fat from other sources. Areas from which energy is not easily mobilized are retrobulbar and perirenal fat where the tissue serves a structural function. Adipose tissue lipase is sensitive to stimulation by both epinephrine and norepinephrine. Other hormones that activate lipase are adrenocorticotrophic hormone (ACTH), thyroid-stimulating hormone (TSH), growth hormone, thyroxine (T<sub>4</sub>), 3,5,3'-triiodothyronine (T<sub>3</sub>), cortisol, glucagon, as well as vasopressin and human placental lactogen (hPL).

Lipase enzyme activity is inhibited by insulin, which appears to be alone as the major physiologic antagonist to the array of stimulating agents. When both glucose and insulin are abundant, transport of glucose into fat cells is high, and glycerophosphate production increases to esterify fatty acids.

The carbohydrate and fat composition of the fuel supply is constantly changing, depending on stresses and demands. Because the central nervous system (CNS) and some other tissues can utilize only glucose for energy, a homeostatic mechanism for conserving carbohydrate is essential. When glucose is abundant and easily available, it



is utilized in adipose tissue for producing glycerophosphate to immobilize fatty acids as triglycerides. The circulating level of free fatty acids in muscle, therefore, is low, and glucose is used by all of the tissues.

When carbohydrate is scarce, the amount of glucose reaching the fat cells declines, and glycerophosphate production is reduced. The fat cell releases fatty acids, and their circulating levels rise to a point where glycolysis is inhibited. Thus, carbohydrate is spared in those tissues capable of using lipid substrates. If the rise of fatty acids is great enough, the liver is flooded with acetyl CoA. This is converted into ketone bodies, and clinical ketosis results.

In the simplest terms, when a person eats, glucose is available, insulin is secreted, and fat is stored. In starvation, the glucose level falls, insulin secretion decreases, and fat is mobilized.

If only single large meals are consumed, the body learns to convert carbohydrate to fat very quickly. Epidemiologic studies with schoolchildren demonstrated a positive correlation between fewer meals and a greater tendency toward obesity.<sup>32</sup> The person who does not eat all day and then stocks up at night is promoting an increase in fat.

# CLINICAL OBESITY

---

# Leptin and the Ob Gene (the LEP Gene in Humans)

The hypothalamic location of the appetite center was established in 1940 by the demonstration that bilateral lesions of the ventromedial nucleus produce experimental obesity in rats. Such lesions lead to hyperphagia and decreased physical activity. Interestingly, this pattern is similar to that seen in human beings—the pressure to eat is reinforced by the desire to be physically inactive. The ventromedial nucleus was thought to represent an integrating center for appetite and hunger information. Destruction of the ventromedial nucleus was believed to result in a loss of satiety signals, leading to hyperphagia. Overeating and obesity, however, are not due to ventromedial nucleus damage but rather to destruction of the nearby regions.<sup>33</sup> Indeed, lesions of the ventromedial nucleus produced by radiofrequency current fail to cause obesity. More recent studies established the arcuate nucleus in the hypothalamus as the central location for the regulation of feeding behavior. A sudden onset of hyperphagia can be due to a hypothalamic lesion. Possible causes include tumors, trauma, inflammatory processes, and aneurysms.

Signals arriving at these CNS centers originate in peripheral tissues. Opiates, substance P, and cholecystokinin play a role in mediating taste, the gatekeeper for feeding, while peptides released from the stomach and intestine act as satiety signals.<sup>34</sup> In addition, the CNS centers are regulated by locally released neuropeptides. Neuropeptides that inhibit appetite include corticotropin-releasing hormone (CRH), neurotensin, oxytocin, and cyclo(HisPro), a peptide derived by proteolysis of thyrotropin-releasing hormone.<sup>35,36</sup> The control of food intake and energy expenditure is very complex, and no agent or system functions in isolation.

The word leptin is derived from the Greek word, “leptos,” which means thin. **Leptin is a 167-amino acid peptide secreted primarily by the adipose tissue that circulates in the blood bound to a family of proteins and acts on the central nervous system neurons that regulate eating behavior and energy balance.** Rat studies in the 1950s suggested the existence of a hormone in adipose tissue that regulated body weight through an interaction with the hypothalamus.<sup>37,38</sup> But it was not until 1994 that the Ob gene was identified, the gene responsible for preventing obesity in the mouse.<sup>39,40</sup> In the human, this gene is known as the LEP gene (Table 19.1, Figure 19.4).

## TABLE 19.1 Genetic Rodent Models of Obesity

	Single Gene Mutations	Gene Product	Rodent Chromosome	Human Chromosome
Mice:	ob/ob	Leptin	6	7
	db/db	Leptin receptor	4	1
	fat/fat	Carboxypeptidase E	8	11
	tub/tub	Phosphodiesterase	7	4
	Ay/Ay	Agouti protein	2	20
Rats:	fa/fa	Leptin receptor	5	1



**FIGURE 19.4**

There are at least four recessive gene mutations known in mice and one dominant mutation (Ay/Ay) that result in obesity syndromes.<sup>41</sup>

Ob/ob and db/db mice were described many years ago. The ob/ob mutation arose spontaneously in the Jackson Laboratory mouse colony in 1949. The ob/ob mouse is homozygous for a mutation of the Ob gene on chromosome 6, and the db/db mouse, discovered in 1966, is homozygous for a mutation of the Db gene on chromosome 4.<sup>41,42</sup> These mice have been the subject of thousands of publications. The product of the Ob gene is leptin, and in the human, the LEP gene is located on chromosome 7q31.3. Db is the diabetes gene, and this is the locus of the mouse leptin receptor gene. Thus, the ob/ob mouse is obese because it does not produce leptin, and the db mouse is obese because it cannot respond to leptin; its leptin levels are very high (the mutation alters the leptin receptor).

Fat/fat mice are obese and remain insulin sensitive; the mutation decreases carboxypeptidase E, an enzyme that is involved in the conversion of prohormones to hormones; for example, proinsulin to insulin. The biology of tub is yet unknown. Both homozygous Fat and Tub mutations cause slowly developing but ultimately severe obesity conditions. Although hyperinsulinemia, hyperactivity of the  $\beta$  cell of the islets of Langerhans, and  $\beta$ -cell degranulation are consistent features, these obesity syndromes do not progress to severe diabetes.

The Ay/Ay rodent becomes fat late in life. The Agouti gene encodes a protein produced by hair follicles. This protein binds to a melanocortin receptor in melanocytes

in the skin, thus preventing melanocyte-stimulating hormone (MSH) action. Agouti rats have high levels of this protein and have yellow instead of black fur. The melanocortins are a group of peptide hormones, which include ACTH and the different forms of MSH, all of which are derived from proopiomelanocortin (POMC). POMC is produced by POMC neurons located in the hypothalamus, within the arcuate nucleus. Melanocortin binding to its brain receptor decreases appetite.<sup>43,44</sup> Ay/Ay rodents make an excess of Agouti protein, blocking melanocortin action, leading to obesity. The importance of this pathway is evident in the report of mutations within the POMC gene characterized by deficiencies in both MSH and ACTH, yielding individuals with obesity, adrenal insufficiency, and red hair pigmentation.<sup>45</sup> These findings have culminated in the recognition that mutations in the melanocortin receptor gene account for the most common cause of familial human obesity that can be attributed to a single gene.<sup>46</sup>

**Energy expenditure is composed of the basal metabolic rate, diet- and temperature-induced heat production, and the energy necessary for physical activity. Leptin induces weight loss in mice due to decreased appetite and food consumption and an increase in heat production and activity.<sup>47</sup>**

## The Leptin Receptor

The leptin receptor belongs to the cytokine receptor family.<sup>42</sup> There are multiple isoforms with at least three major forms, a short form and a long form, OB-R<sub>S</sub> and OB-R<sub>L</sub>, plus a circulating protein that consists of the extracellular domain. The extracellular domain is very large with 816 amino acids. The intracellular domain of the short form contains 34 amino acids, and in the long form, about 303 amino acids. The short form has many variations, whereas the long form is the common signaling receptor. The only place that the long form is expressed in greater amounts than the short forms is in the hypothalamus, in the arcuate, ventromedial, paraventricular, and dorsomedial nuclei.<sup>48,49</sup> High levels of the short-form leptin receptors in the choroid plexus indicate a transport role for the short form from blood into the cerebrospinal fluid to diffuse into the brain.<sup>50</sup>

The class I cytokine receptor family (to which the long form belongs) acts by proteins that phosphorylate the receptor after binding and STAT proteins that are activated after phosphorylation and then translocate to the nucleus and stimulate gene transcription. The long-form receptor works through STAT proteins, but gene knockouts specific for STAT proteins are not obese, indicating the presence of other signaling pathways activated by leptin.

The Db gene encodes the leptin receptor. The Db mutation converts the long form to the inactive short form, resulting in leptin resistance and obesity. The db/db mouse has a

single G for T nucleotide substitution within the C terminal untranslated end of the short intracellular domain of the ob receptor. This results in a new splice site that creates an abnormal exon inserted into the messenger RNA (mRNA) that encodes the long intracellular domain of the ob receptor. As a result, the long-form mRNA in db/db mice encodes a protein with most of the intracellular domain truncated to be similar to the short form of the ob receptor. The fa/fa mutation is a glutamine for proline substitution in the extracellular domain, and in contrast to the db/db mouse, the fa/fa rat will respond to leptin, but only if it is delivered into the brain.<sup>51</sup>

## Ghrelin

Ghrelin is a complex hormone, named for its ability to stimulate the release of growth hormone. Ghrelin not only participates in the regulation of food intake and energy metabolism but also affects sleep and behavior, and inhibits gonadotropin secretion.<sup>52,53,54</sup> It influences a wide spectrum of activities, including gastric motility and acid secretion, activity of the pancreas, and the secretion of growth hormone, prolactin, and ACTH.<sup>55</sup>

Ghrelin is a 28-amino acid peptide discovered in 1999 that is secreted mainly in the upper portion of the stomach, but in other tissues as well, including the intestine, pituitary, hypothalamus, kidney, ovary, testis, and placenta.<sup>56</sup> The ghrelin circulating in the blood is predominantly from the stomach and intestine, and its target is the energy-regulating centers in the hypothalamus. Given to rodents, ghrelin acutely increases food intake and causes obesity. These actions of ghrelin are independent of its activity in stimulating growth hormone, prolactin, and ACTH secretion, an action that is probably mediated by different ghrelin receptors.<sup>57</sup> The targeted neurons are in the same network influenced by leptin (principally the NPY/AgRP and POMC), with ghrelin and leptin having opposing actions. Another stomach hormone, PYY, acts in a similar fashion as leptin, reducing food intake by modifying the NPY/AgRP system; this leaves ghrelin as the only hormone known that stimulates food intake.<sup>58</sup>

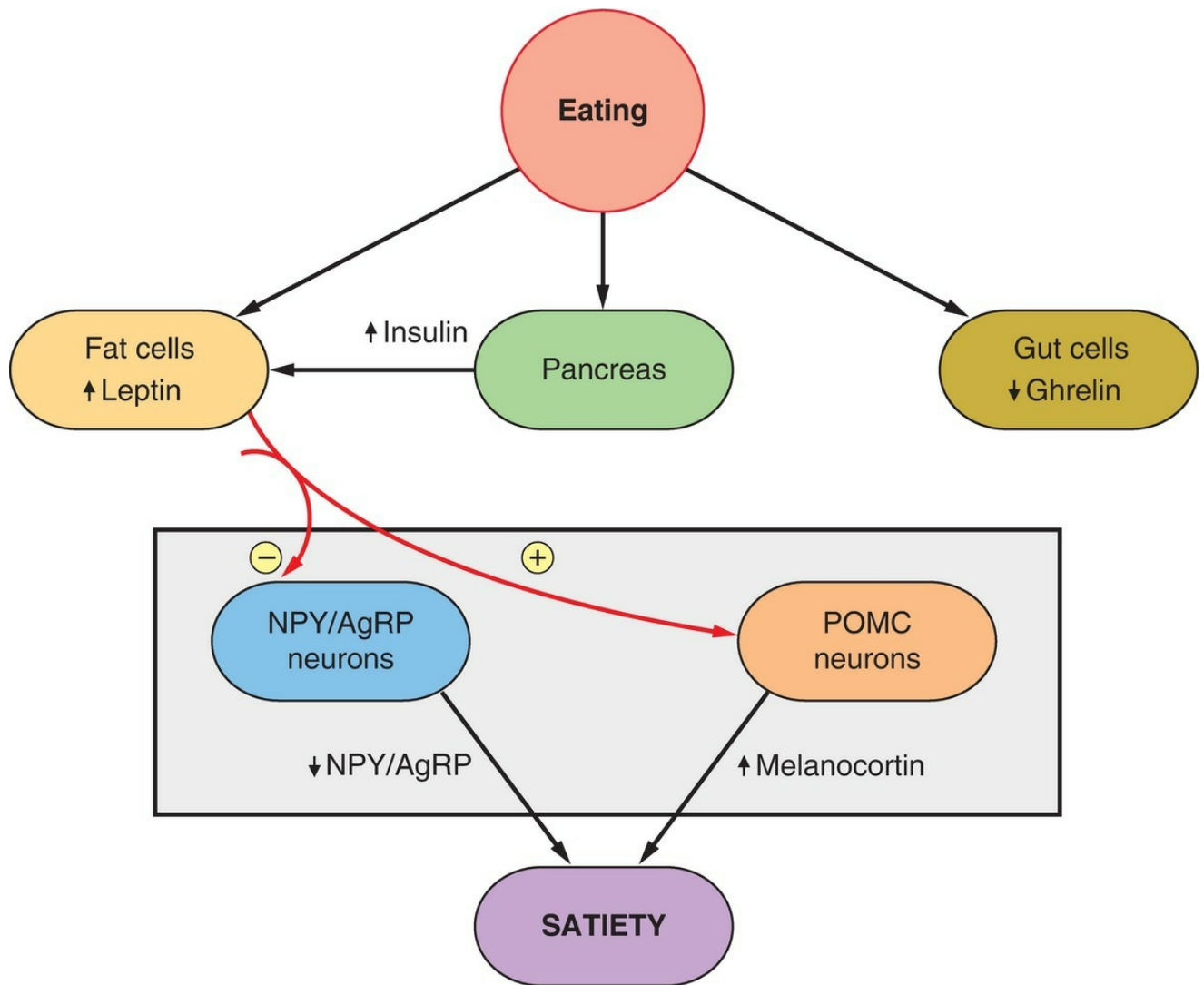
The circulating level of ghrelin is lower in obese individuals, reduced with food intake and increased with fasting. Thus, ghrelin levels are higher in individuals with anorexia, bulimia, or cachexia, and, in contrast to its appetite-stimulating action in healthy individuals and in patients with cancer cachexia, administration of ghrelin intravenously to young women with anorexia nervosa does not increase appetite.<sup>59,60,61</sup> These changes are opposite to those of leptin. Ghrelin is a signal to conserve energy by increasing appetite; leptin (and insulin) is a signal to expend energy.<sup>59</sup> The key regulator in these responses is the circulating glucose level, but in the case of ghrelin, the system is influenced by meals, whereas leptin is modulated by fat mass. **The connection**

**between reproduction and the body's state of energy metabolism is now well established, and the complex leptin-ghrelin system is the means of communication. Specifically, ghrelin exerts a CNS inhibition to prevent reproduction in the presence of an energy deficit, with leptin and ghrelin operating as reciprocal regulators.<sup>62</sup>**

# The Physiologic Feedback Loop Involving the Arcuate Nucleus

In the hypothalamus, a subset of neurons located in the arcuate nucleus that produce neuropeptide-Y (NPY) and agouti-related peptide (Agrp) play a central role in the promotion of feeding (**Figure 19.5**).<sup>63,64,65,66,67,68,69</sup> NPY is a 36-amino acid polypeptide that is a potent stimulator of eating when injected directly into the rodent brain.<sup>70</sup> NPY has a tyrosine at both ends, hence the use of Y to stand for tyrosine. NPY stimulates food intake, decreases heat production, and increases insulin and cortisol secretion. Agouti-related protein (AgRP), also called Agrp, is a 112-amino acid neuropeptide produced in the brain by the AgRP/NPY neuron. AgRP is expressed primarily in the adrenal gland, subthalamic nucleus, and hypothalamus, with lower levels of expression in the testis, kidneys, and lungs. In the hypothalamus, it is synthesized only in NPY-containing cell bodies located in the ventromedial part of the arcuate nucleus.<sup>71</sup> AgRP was independently identified by two teams in 1997 based on its sequence similarity with agouti signaling peptide (ASIP), a protein synthesized in the skin that controls coat color.<sup>72,73</sup> The NPY/AgRP neurons are activated when the body is lacking sufficient energy, such as during periods of fasting and food deprivation.<sup>74,75,76,77,78</sup> Indeed, when the body has a negative energy balance, glucose levels are lower, and there is increased firing of NPY/AgRP neurons.<sup>79</sup> The appetite-stimulating effects of NPY/AgRP neurons are inhibited by the hormone leptin and activated by the hormone ghrelin.<sup>80,81</sup>





**FIGURE 19.5**

In close proximity to NPY/AgRP neurons, another population of neurons produce pro-opiomelanocortin (POMC) neurons, which has the opposite effect on feeding (**Figure 19.6**).<sup>82,83</sup> POMC neuron activity increases when glucose levels rise, consistent with the role of POMC cells as satiety signaling neurons.<sup>79,84,85,86</sup> Activation of the POMC neurons causes the release of  $\alpha$ -melanocyte-stimulating hormone ( $\alpha$ -MSH) from their axon terminals.  $\alpha$ -MSH activates melanocortin receptor 4 (MC4R) and leading to the suppression of food intake and increased in energy expenditure.<sup>82,87,88</sup> In contrast, activation of NPY/AgRP neurons causes the release of AgRP, which antagonizes the effect of  $\alpha$ -MSH on MC4R.<sup>66,82,87,88,89</sup>

In addition to an antagonistic action on MC4Rs, blocking the effect of anorexigenic melanocortin cells, the NPY/AgRP system also has a direct inhibitory effect on POMC perikarya.<sup>90,91,92</sup> Such inhibition involves NPY and GABA, a small inhibitory amino

acid neurotransmitter.<sup>87,90,91,92,93</sup> This unidirectional interaction between the NPY/AgRP and POMC perikarya is noteworthy as it provides tonic inhibition of the melanocortin cells whenever the NPY/AgRP neurons are active.<sup>91,93,94,95</sup> This anatomical organization might, at least in part, explain why the feeding circuit is more likely to induce feeding rather than satiety. While this bias toward a positive energy balance would be useful from an evolutionary perspective, it is also a likely contributor to the etiology of contemporary metabolic disorders.

Serum glucose and free fatty acid levels that regulate AMP kinase (AMPK) activity and therefore conversion of AMP to ATP impact upon the activities of the orexigenic NPY/AgRP-producing neurons and the anorexigenic POMC/ $\alpha$ -MSH-expressing neurons. In addition to circulating glucose and free fatty acids, the activities of NPY/AgRP and POMC neurons are also regulated by peripheral metabolic regulatory hormones—including leptin, ghrelin, and insulin—that respond to the metabolic state of the organism.

Leptin, which is secreted primarily by the adipose tissue in proportion to adipose tissue mass, and suppresses appetite, enhances POMC neuron activity via both pre- and postsynaptic modes of action, whereas the orexigenic NPY/AgRP neurons' activity is diminished by leptin.<sup>87,96,97</sup> It is noteworthy that leptin, not only acts on existing synapses but also promotes rewiring in the arcuate nucleus, and leptin-mediated plasticity in the hypothalamus may underlie some of the hormone's behavioral effects.<sup>98</sup>

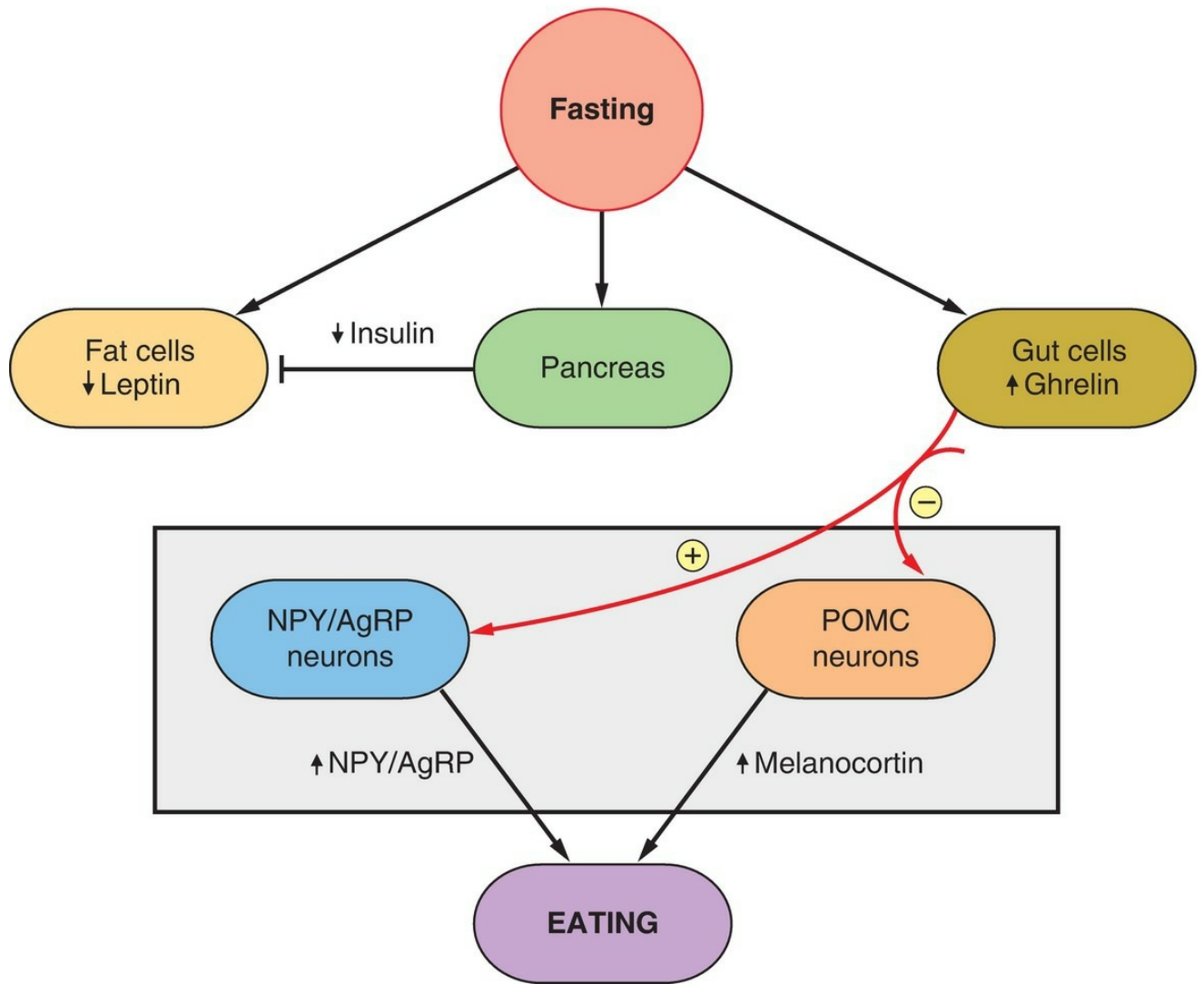
In normal mice, leptin decreases NPY,<sup>99</sup> while in ob/ob mice with no leptin, NPY levels are high in the hypothalamus, and leptin treatment lowers NPY.<sup>48</sup> Fasting and exercise decrease leptin secretion and increase NPY/AgRP expression in the arcuate nucleus. Importantly, fasting decreases leptin more than expected by the decrease in fat content, indicating the presence of other control mechanisms.<sup>100</sup> In most animal models, the NPY content in the hypothalamus is high with obesity, and brain infusions of NPY cause obesity and increased Ob gene expression.<sup>101</sup> In contrast, the gut-derived appetite-stimulating hormone ghrelin is secreted in response to negative energy balance (e.g., fasting) and up-regulates NPY/AgRP neuron activity via a direct mechanism, whereas it decreases the action potential frequency of POMC cells predominantly by a presynaptic mode of action.<sup>102,103</sup> The pancreas-derived hormone insulin was also shown to affect neuronal activity in the arcuate nucleus, possibly acting on ATP-sensitive potassium channels.<sup>104</sup>

A number of studies using mouse knockout models support the conclusion that the activities of metabolic hormones and NPY/AgRP and POMC neurons are required for the regulation of energy metabolism. The deficiency of POMC-derived peptides results in partially penetrant embryonic lethality. These mice also show obesity, in addition to a

defective adrenal development and altered pigmentation.<sup>105</sup> MC4R knockouts exhibit obesity, hyperphagia, insulin resistance, hyperinsulinemia, and hyperglycemia,<sup>40,44,106,107</sup> while MC3R knockouts develop metabolic syndrome with increased adipose mass and decreased energy expenditure.<sup>108</sup> Mice lacking NPY have increased sensitivity to leptin and susceptibility to seizures.<sup>109</sup> While early deletion of AgRP or both AgRP and NPY does not seem to significantly alter energy metabolism, ablation of Agrp neurons in adult mice results in anorexia and death.<sup>110,111,112</sup> As previously discussed, mice homozygous for leptin mutation (Ob/Ob) are obese, have high metabolic efficiency, impaired thermogenesis, short life span, and abnormalities in many organ systems including the cardiovascular, respiratory, nervous, and gastrointestinal systems.<sup>113</sup> Similarly, mice deficient in leptin receptor are also obese, hyperinsulinemic, and hyperglycemic.<sup>114,115</sup> In contrast, when placed on regular diet, ghrelin knockouts do not demonstrate phenotypic abnormalities, while they display increased utilization of fat as an energy substrate on a high fat diet and enhanced glucose-induced insulin release.<sup>116,117</sup>

## Leptin and Insulin

In rodents, insulin increases the expression of the Ob gene, but there is controversy in humans.<sup>47</sup> In humans, there is no acute surge of leptin after meals, and the administration of insulin does not stimulate an acute increase in leptin levels. Indeed, in the human, the LEP gene does not appear to be acutely regulated; feeding increases leptin levels, but slowly, correlating with insulin levels.<sup>118,119,120</sup> An increase in LEP gene expression also occurs in humans with chronic insulin stimulation, a situation that would be similar to overeating.<sup>121</sup> It is likely that insulin is at least one regulator of the LEP gene and its secretion of leptin. It is noteworthy that insulin provides negative feedback to the brain in a manner similar to leptin, including an effect on NPY (**Figure 19.6**).<sup>70</sup> The hyperphagia of diabetes mellitus reflects a deficiency in this insulin action. In fa/fa rats (obese because of a mutation in the leptin receptor), insulin does not affect NPY expression, indicating that the inhibition of NPY exerted by insulin is mediated through the leptin-signaling system.<sup>122</sup>



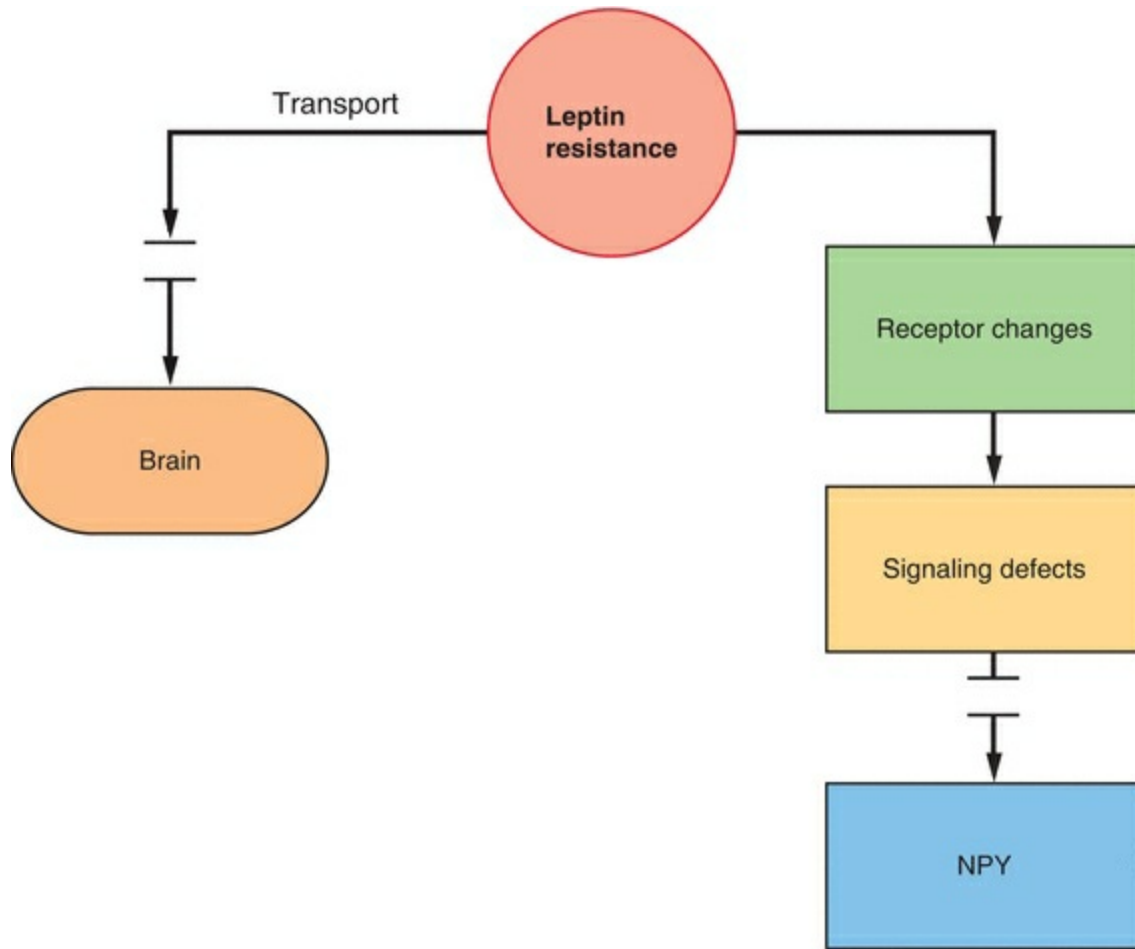
**FIGURE 19.6**

# Leptin in Obese People

Most studies have indicated that nearly all obese individuals have elevated leptin levels, probably due to an increase in LEP gene expression and partly due to greater production because of larger fat cells.<sup>123,124,125</sup> The greater weight of these individuals represents the leptin level at which stability is achieved. In lean individuals, leptin levels are similar in men and women, but in women, as weight increases, leptin increases 3 times more rapidly than in men.<sup>126</sup> Higher levels in women suggest a greater resistance to leptin, correlating with a greater prevalence of obesity.<sup>127</sup>

The incidence of obesity in black and Hispanic women is greater than that of white women.<sup>1</sup> Obese postmenopausal black women have 20% lower leptin levels than white women.<sup>128</sup> These lower leptin levels correlate with a lower resting metabolic rate in the black women. The lower levels may indicate a greater sensitivity to the leptin mechanism in black women.

In obese individuals, fat cells produce leptin normally, and a prevalent genetic failure has not been identified. **Thus, it is hypothesized that obesity is due to resistance to leptin.**<sup>129</sup> This may be due to a transport problem of leptin into the brain, as indicated by the finding that leptin level differences between obese and lean individuals are greater in blood than in cerebrospinal fluid.<sup>130,131</sup> At least in the mouse, this resistance is present only in the periphery in that leptin administered in the brain still works<sup>132</sup> (**Figure 19.7**).



**FIGURE 19.7**

In obese individuals, the majority of leptin is unbound and presumably active, consistent with the resistance hypothesis.<sup>133</sup> In lean individuals, the majority of circulating leptin is bound. Another important subject for research is the regulation of leptin binding to proteins in the circulation.

# Why Is Weight Loss So Hard to Maintain?

The average adult eats nearly 1 million calories per year.<sup>41</sup> When life was tougher, leptin served the purpose of meeting the threat of starvation. During periods of food availability, individuals with leptin defects could consume large amounts and store excess fat. Today, with no shortage of food, the individuals who survived during food shortages in the past now become obese, and succumb to the complications of obesity. But the most vexing problem is that 90–95% of people who lose weight subsequently regain it.<sup>134</sup>

Weight loss in obese and lean people produces the same response, decreased leptin and insulin, and an increase in ghrelin. The obese person tends to regain weight because the lower leptin started from a different set point and is now lower than what the body views as required to be stable in terms of the amount of fat. The ghrelin response also makes it more difficult by stimulating appetite. When energy expenditure, food intake, and body weight are in balance, leptin and ghrelin are at a level consistent with a set point determined by this balance. With weight loss and loss of fat, leptin decreases and ghrelin increases, causing an increase in appetite and a decrease in energy. This is great when you lose weight with an illness, but not good for an overweight person trying to lose weight. Whenever a perturbation occurs, leptin and ghrelin levels change to restore the original status quo, making it difficult for overweight people to maintain weight loss. With both sustained weight loss and persistent weight gain, hormonal mechanisms as well as energy adjustments to maintain lower or higher body weights eventually lead to new set points. However, in the short-term, weight loss can be maintained only by a strict diet or an increase in physical activity to overcome the body's attempt to restore the original set point.

Circulating levels of leptin are correlated with the percent body fat.<sup>123</sup> In other words, increased body fat increases the expression of the LEP gene in fat cells. The amount of leptin in the circulation, therefore, is a measure of the amount of adipose tissue in the body. For this reason, neither baseline levels nor initial changes in leptin predict whether weight loss can be maintained.<sup>135</sup>

A reduction of 10% in body weight is associated with a 53% reduction in serum leptin.<sup>123</sup> This would stimulate an effort to regain the weight. The key question is what happens if an individual can successfully maintain the lower weight. In a longitudinal study of obese people, when weight loss was maintained, leptin levels remained low.<sup>136</sup>

**Whenever a perturbation occurs, leptin and ghrelin levels change to restore the original status quo; these responses work against attempts to lose weight. A change in energy intake causes a change in leptin levels.<sup>122</sup> The body then changes**

**appetite and energy expenditure to conform to the new leptin level. A 10% increase in body weight is associated with a 300% increase in serum leptin.<sup>119</sup> The basic purpose is to conserve energy during periods of fasting and to avoid obesity during periods of excess. When caloric intake is reduced, the basal metabolic rate is reduced in a regulatory compensatory adaptation that makes maintenance of weight loss difficult.**



# Congenital Leptin Deficiency

The LEP gene (Ob gene in mice) has been sequenced from hundreds of obese individuals, and mutations are rare.<sup>129,137</sup>

The first definitive demonstration of a congenital leptin deficiency in humans was reported in two severely obese Pakistani children who were cousins.<sup>138</sup> Despite their mass of fat, their serum leptin levels were very low, and the molecular biology study of a fat biopsy revealed a homozygous deletion of a single guanine in the leptin gene. This mutation results in the introduction of 14 aberrant amino acids into the leptin peptide followed by a premature truncation. All four parents were heterozygotes. These children had normal birth weights, but immediately began gaining excessive weight with marked increases in appetites. In contrast to ob/ob mice, they did not have elevated cortisol levels; however, they were hyperinsulinemic. Three obese members of a Turkish family were reported with an amino acid substitution that impairs intracellular transport of leptin.<sup>139</sup> It is noteworthy that these individuals also displayed suppression of gonadal function. Congenital leptin deficiency is now recognized as a rare recessive inherited disorder, the result of mutations at various sites on the LEP gene and associated with hyperphagia and the onset of obesity at an early age.<sup>140</sup> Polymorphisms have been described in both the leptin gene and the leptin receptor gene, more prevalent in extremely obese patients, but a relatively low overall prevalence in obese individuals.<sup>141</sup>

With the complexity of the system for energy regulation and the large number of hormones and enzymes involved, we can expect to see multiple mutations identified. An obese individual was reported with a mutation in prohormone convertase (an enzyme that participates in the conversion of prohormones into hormones as does the carboxypeptidase E enzyme deficient in the fat/fat mouse).<sup>142</sup> Linkages to obesity have been described to regions near the leptin gene or the leptin receptor gene, perhaps indicating differences in regulatory elements of these genes.<sup>143</sup> Remember that melanocortin peptides, along with NPY, are part of the leptin signaling pathway in the hypothalamus. Mutations in the melanocortin 4 receptor gene<sup>144</sup> are said to be the most frequent monogenetic cause of obesity, yet the 1% or 2% prevalence of this mutation in obese individuals is insufficient to warrant screening.<sup>145</sup> It is noteworthy that obese children with melanocortin 4 receptor gene mutations were able to lose weight with lifestyle interventions, but had greater difficulty in maintaining their weight loss.<sup>146</sup>

**It is expected that only a small percentage (<5%) of obese humans will have mutations in the leptin receptor or the LEP gene, but congenital leptin deficiency of the leptin receptor should be considered in children with hyperphagia and severe**

obesity.

## Leptin and Reproduction

Several observations support a role for leptin in reproductive physiology.

### Key Points

- Leptin administration accelerates the onset of puberty in rodents.<sup>147</sup>
- Leptin levels increase at puberty in boys.<sup>148</sup> Indeed, nocturnal levels of leptin increase in monkeys before the nocturnal increase in pulsatile secretion of LH.<sup>149</sup>
- Low leptin levels are present in athletes and in patients with anorexia and delayed puberty.<sup>150</sup>
- The ob/ob mouse undergoes normal sexual development but remains prepubertal and never ovulates; fertility is restored with leptin administration.<sup>147</sup> A similar presentation and response were reported in a child with congenital leptin deficiency.<sup>151</sup>

Leptin levels are greater in females than in males, and in premenopausal women compared with postmenopausal women.<sup>152</sup> In girls, leptin levels are higher and decrease with increasing Tanner stages of puberty.<sup>153</sup> Thus with puberty, there is increasing sensitivity to leptin. Or in another way to look at this relationship, decreasing leptin during puberty may allow greater food intake for growth by lowering the satiety signal.

The effect of leptin on reproduction can be viewed as an additional role in maintaining responses to stress. Weight loss is known to be associated with an increased adrenal response and a decrease in thyroid function; these endocrine changes, along with suppression of the estrous cycle, occur in fasted mice and are reversed by treatment with leptin.<sup>154</sup>

The puzzle is why CRH is elevated in stress amenorrhea (especially that associated with weight loss) in contrast to the decrease with fasting in normal and obese individuals. One possibility is that the decrease in leptin and increase in NPY associated with stress-related weight loss is the expected response, but it is inadequate to suppress the stress-induced increase in CRH. The blunted patterns in amenorrheic athletes support this. The increase in CRH and resulting hypercortisolism further increase metabolism and weight loss.

Athletes with cyclic menses demonstrate a normal diurnal rhythm in leptin levels. However, amenorrheic athletes do not have a diurnal pattern.<sup>155</sup> Both cycling athletes and amenorrheic athletes have low leptin levels (threefold reduction) that correlate with reduced body fat, but the levels are further lowered by hypoinsulinemia and hypercortisolemia. In addition, amenorrheic athletes have a blunted leptin response to the increase in insulin following meals. In postmenopausal women, leptin levels decrease with endurance training, and hormone therapy has no effect.<sup>156</sup> This indicates that the gender difference (higher levels in women) is due to a difference in fat content, not a hormonal difference.

Because of the tight connection between insulin and leptin levels in mice, and the now well-recognized prevalence of hyperinsulinemia in women with polycystic ovaries, it makes sense to investigate leptin levels in these women. Studies, controlling for weight, detected no differences in leptin levels comparing women with and without polycystic ovaries.<sup>157,158,159,160</sup> In women with polycystic ovaries, the relationship between leptin and body weight is maintained. Thus, in contrast to the rodent model, hyperinsulinemia and insulin resistance do not affect leptin levels in these women. However, a role for leptin in the changes associated with polycystic ovaries should not yet be discounted. There may be subtle differences that have biologic consequences. At least one study demonstrated a correlation between leptin levels and 24-hour insulin levels in women with polycystic ovaries.<sup>157</sup> Furthermore, a drug that lowers insulin resistance, troglitazone, inhibits transcription of the LEP gene.<sup>161</sup>

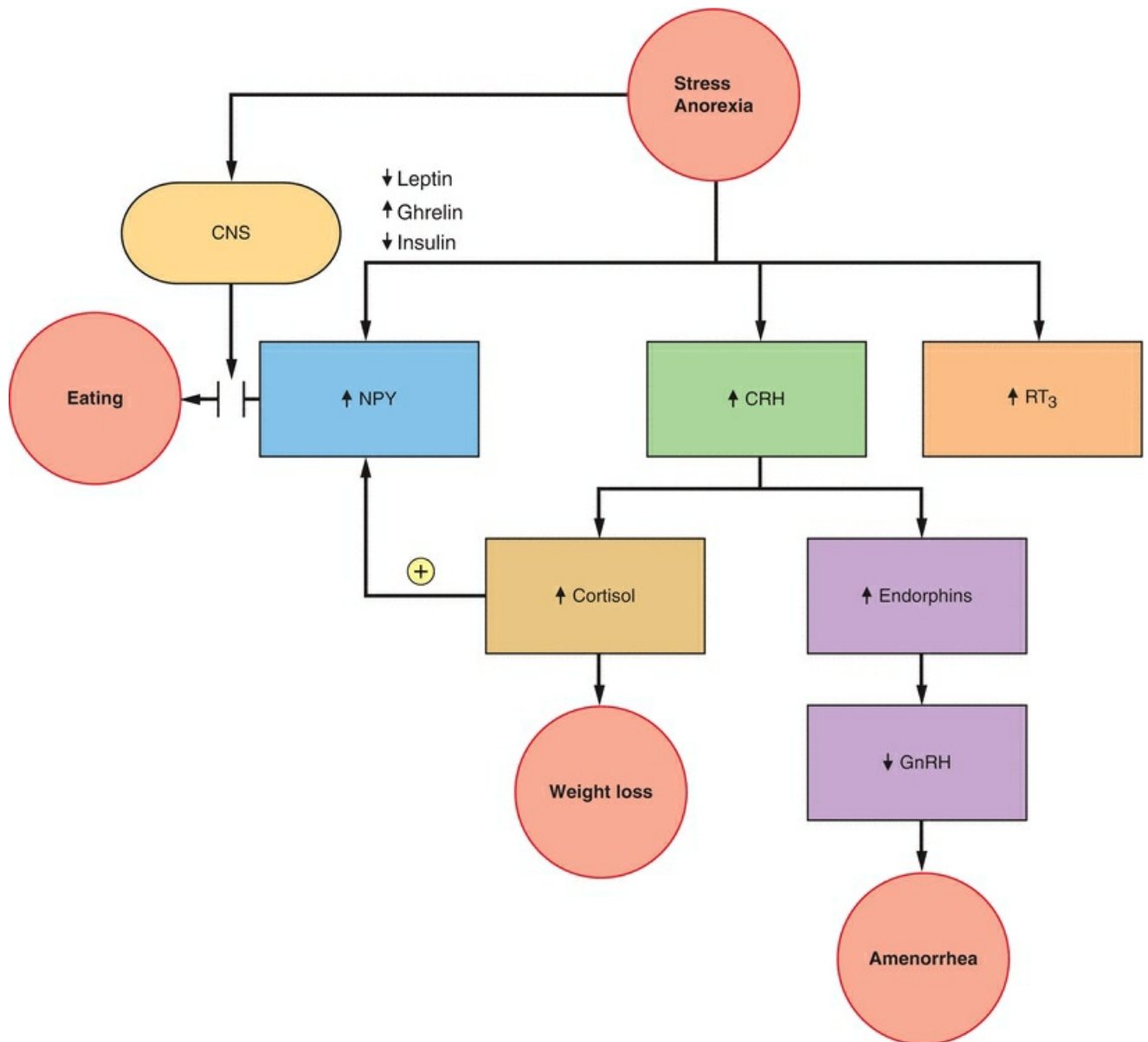
Is it possible that leptin has a target tissue role in reproduction? An isoform of leptin has been identified in the ovary, and leptin exerts specific actions on steroidogenesis as studied *in vitro*.<sup>162,163</sup> Leptin inhibits the synergistic action of insulin-like growth factor-I (IGF-I) on FSH-stimulated estradiol production (but not progesterone) in rat granulosa cells and also inhibits FSH stimulation of IGF-I production. In addition, leptin is expressed in human granulosa and cumulus cells and is present in mature human oocytes and follicular fluid; thus, leptin appears to be secreted by the ovarian follicle.<sup>164</sup> A rise in maternal serum leptin levels after the administration of human chorionic gonadotropin and before ovum retrieval was correlated with a higher pregnancy rate.<sup>164</sup> Leptin, therefore, is involved in a multitude of important metabolic and developmental functions.

The leptin-ghrelin story has restored credibility to the critical weight hypothesis originally proposed by Rose Frisch in the 1970s.<sup>165,166</sup> The critical weight hypothesis states that the onset and regularity of menstrual function necessitate maintaining weight above a critical level, and, therefore, above a critical amount of body fat. It was always a mystery how total body fat could talk with the brain. A mystery no longer! Fat talks to the brain via leptin, and the leptin system affects reproduction. Recombinant human

leptin administration to women with hypothalamic amenorrhea secondary to exercise or weight loss was associated with an increase in the levels of gonadotropins, free thyroxine, and insulin-like growth factor, with a resumption of ovarian activity.<sup>167</sup> In addition, ghrelin secretion by the gastro-intestinal tract is involved in this balancing mechanism. Ghrelin levels are increased in anorectic patients, along with elevations in cortisol.<sup>168</sup>

There is a difference, however, between ordinary weight loss and stress-induced (e.g., exercise or psychologic problems such as anorexia) weight loss. In ordinary weight loss, CRH secretion is reduced. In stress-induced weight loss, CRH secretion is increased.

CRH directly inhibits hypothalamic gonadotropin-releasing hormone (GnRH) secretion, probably by augmenting endogenous opioid secretion. Women with hypothalamic amenorrhea (including exercisers and women with eating disorders) demonstrate hypercortisolism (due to increased CRH and ACTH, perhaps augmented by NPY stimulation of ACTH secretion), suggesting that this is the pathway by which stress interrupts reproductive function.<sup>169</sup> The modulating effect of the leptin-ghrelin system appears to be mediated through CRH.<sup>170</sup> In addition, NPY and AgRP directly inhibit gonadotropin release by suppressing GnRH.<sup>171</sup> In regard to reproduction, the final pathway is suppression of GnRH, a response to multiple inputs indicating the availability of metabolic fuel. The clinical presentation (inadequate luteal phase, anovulation, amenorrhea) depends on the degree of GnRH suppression. Nevertheless, stress and weight loss–induced suppression of reproductive function is associated with low leptin levels, and administration of leptin improves function.<sup>167,172</sup> Unfortunately, the administration of leptin in these patients further suppresses appetite and increases weight loss<sup>167</sup> (**Figure 19.8**).



**FIGURE 19.8**

A unifying hypothesis focuses on energy balance.<sup>173</sup> When available energy is excessively diverted, as in exercise, or when insufficient, as with eating disorders, reproduction is suspended in order to support essential metabolism for survival. Thus, reproduction may not be directly affected by the level of body fat; rather, body fat is a marker of the metabolic energy state, and the extremely low leptin levels in anorexic patients are an appropriate attempt to restore appetite, an attempt that fails to overcome the stress-induced increase in CRH and its consequences. From a teleologic point of view, there is sense to these relationships; the responses that assist the body to withstand stress also inhibit menstrual function because a stressful period is not the ideal time for reproduction.

# Leptin Summary

Because of the high levels of leptin present in overweight people, leptin function may be limited to an effect at low levels. A low circulating level of leptin may serve as a signal that fat stores are not sufficient for growth and reproduction. Thus, low levels would ordinarily stimulate hyperphagia, reduce energy expenditure, and suppress gonadotropin secretion and reproduction. The high levels of leptin and the lack of leptin action associated with excess body weight and fat would then reflect resistance.

Although the leptin-ghrelin mechanism offers the potential for new treatments for obesity, it is not around the corner. Leptin, a polypeptide, cannot be administered orally, and in view of high levels in overweight people, another method must be found to attack the lack of effect, the apparent resistance to leptin. Thus far, it appears that genetic defects in the LEP gene are uncommon; nevertheless, for affected individuals, a leptin agonist is therapeutic. Even if this complex system yields new treatments, it is unlikely that we will be able to ignore eating appropriately and exercising adequately.

# INHERITED ASPECTS OF OBESITY

---

Fat cells develop from connective tissue early in fetal life. An important question is whether new fat cells are produced by metaplasia in the adult, or whether an individual achieves a total complement during a certain period of life. In other words, is excess fat stored by increasing the size of the fat cell, or by increasing the number of cells? The possibility arises that there is an inherited increase in the total number of fat cells, which just wait to be packed full of storage fat. Furthermore, the total number of fat cells may depend on an infant's nutritional state during the neonatal period and perhaps in utero as well.

Studies of fat obtained at surgery indicate that the mean fat cell volume is increased threefold in obese people, but an increase in the number of fat cells is seen only in the grossly obese. When patients diet, the fat cells decrease in size but not in number. Hypercellular obesity may be a more difficult problem to overcome, because an individual may be saddled with a permanent increase in fat cells.

Some researchers think that, at some period in a person's life, a fixed number of fat cells is obtained. Adolescence, infancy, and intrauterine life seem particularly critical.<sup>174,175</sup> This premise is not solidly established, because there is no certain way to identify an empty fat cell, and potential fat cells cannot be recognized. Nevertheless, a hyperplastic type of obesity (more fat cells) may be associated with childhood and have a poor prognosis; a hypertrophic type (enlarged fat cells) that is responsive to dieting may occur in adults.

There certainly appears to be a genetic component. The weights of adopted children in Denmark correlated with the body weights of their biologic parents but not with their adoptive parents.<sup>176</sup> This would suggest that the genetic influence is even more important in childhood than environmental factors. Other work suggests that the familial occurrence of obesity can be attributed in part to a genetically related reduced rate of energy expenditure.<sup>177</sup> In studies of identical and fraternal twins reared apart, approximately 70% of the variance in the BMI could be assigned to genetic influences and the remaining 30% to environmental effects.<sup>178</sup> After the age of 3, obesity in childhood predicts obesity in adulthood, and parental obesity doubles the risk of adult obesity in both obese and nonobese children.<sup>179</sup>

Some argue that each individual has a set point, a level regulated by a signal between the fat cells and the brain (the leptin system). According to this argument, previously obese people who have successfully lost weight have to maintain themselves in a state of starvation (at least as far as their fat cells are concerned).

Genetics and biochemistry are against many obese people. It is best to recognize

that an obese individual who has suffered with the problem lifelong does have a disorder. However, for each individual, the extent to which the genetic predisposition is expressed depends on environmental influences. The prevalence of obesity is inversely related to the level of physical activity and directly related to parity.<sup>180</sup> Obesity prevalence is also associated with income and educational level, although patterns might differ between high-income and low-income countries. Using data from the National Health and Nutrition Examination Survey (NHANES), CDC analyzed obesity prevalence among adults in the United States (aged  $\geq 20$  years) by three levels of household income, based on percentage ( $\leq 130\%$ ,  $>130\%$  to  $\leq 350\%$ , and  $>350\%$ ) of the federal poverty level (FPL) and individual education level (high school graduate or less, some college, and college graduate). During 2011–2014, the age-adjusted prevalence of obesity among adults was lower in the highest income group (31.2%) than the other groups (40.8% [ $>130\%$  to  $\leq 350\%$ ] and 39.0% [ $\leq 130\%$ ]). The age-adjusted prevalence of obesity among college graduates was lower (27.8%) than among those with some college (40.6%) and those who were high school graduates or less (40.0%).<sup>181</sup> Similarly, the prevalence of obesity among U.S. youths (2–19 years old) was lower in the highest income group (10.9%) than in the other groups (19.9% and 18.9%) and also lower in the highest education group (9.6%) than in the other groups (18.3% and 21.6%), grouped based on head of household education.<sup>182</sup> Thus, socioeconomic and behavioral factors are important determinants of body weight, and surely, each individual will reflect varying impacts of genetics and environment.



# ENDOCRINE CHANGES

---

The most important endocrine change in obesity is elevation of the basal blood insulin level. The circulating insulin level is proportional to the volume of body fat. Increases in body fat change the body's secretion and sensitivity to insulin, appropriately so because insulin acts to reduce food intake by inhibiting the expression of NPY/AgRP as well as affecting other agents that influence appetite.<sup>122</sup> The effect on NPY/AgRP is believed to be mediated via the leptin signaling system.

Overweight individuals are characterized by insulin resistance. The key factors that affect insulin resistance are the amount of fat tissue in the body, the caloric intake per day, the amount of carbohydrates in the diet, and the amount of daily exercise. At least one mechanism for the increased resistance to insulin observed with increasing weight is down-regulation of insulin receptors brought about by the increase in insulin secretion. The increase in insulin resistance affects the metabolism of carbohydrate, fat, and protein. Circulating levels of free fatty acids increase as a result of inadequate insulin suppression of the fat cell. Insulin resistance results in decreased catabolism of triglycerides, yielding a decrease in HDL cholesterol and an increase in LDL cholesterol. This, of course, is a major mechanism for the development of atherosclerosis. Hyperinsulinemia is also directly associated with hypertension. The hyperinsulinemia associated with obesity is reversible with weight loss. **A significant improvement is achieved with a modest weight loss, only 5–10% of body weight.**

The metabolic syndrome is a serious complication of excess body weight; 60% of obese men and women have the metabolic syndrome.<sup>15</sup> Individuals with the metabolic syndrome have a very high risk of diabetes and cardiovascular disease. **The diagnosis of the metabolic syndrome in an individual requires that three abnormal findings are present out of the five following clinical characteristics<sup>183</sup>:**

- **Hypertension: 130/85 or higher**
- **Triglyceride level: 150 mg/dL or higher**
- **HDL cholesterol levels: less than 50 mg/dL**
- **Abdominal obesity: greater than 35 inches (40 inches in men) waist circumference**
- **Fasting glucose: 110 mg/dL or higher**

**Because of the variability associated with measurements of insulin, the fasting glucose to fasting insulin ratio is no longer recommended to establish the presence of insulin resistance; a 2-hour oral glucose tolerance test is now the preferred method of assessment, with measurement of 2-hour glucose and insulin levels after**

**a 75-g glucose load.**

**Interpretation of the 2-hour glucose response:**

- **Normal: less than 140 mg/dL**
- **Impaired: 140–199 mg/dL**
- **Non–insulin-dependent diabetes mellitus: 200 mg/dL and higher**

**Interpretation of the 2-hour insulin response:**

- **Insulin resistance very likely: 100–150 U/mL**
- **Insulin resistance: 151–300 U/mL**
- **Severe insulin resistance: greater than 300 U/mL**

It is impossible to predict exactly who eventually will develop diabetes because the tendency is recessive, and it will not develop in every generation in a family. But weight is a good tip-off. As weight increases, the frequency of occurrence of diabetes increases. Both gestational diabetes and insulin-dependent diabetes are more common in overweight pregnant patients.

Contrary to popular misconception, hypothyroidism does not cause obesity. Weight gain due to hypothyroidism is confined to the fluid accumulation of myxedema. There is no place, therefore, for thyroid hormone administration in the treatment of obesity when the patient is euthyroid.

The basic question is whether metabolic changes observed in obesity represent adaptive responses to a markedly enlarged fat organ or whether they are representative of a metabolic or hormonal defect. The former is true. These changes are secondary responses; they are totally reversible with weight loss. Four-year follow-up in a group of patients who did not regain their weight after dieting revealed persistently normal insulin and glucose responses; patients who regained their weight showed further deterioration in these metabolic factors.<sup>184</sup>

# ANATOMIC OBESITY

---

Gynoid obesity (the pear shape) refers to fat distribution in the lower body (femoral and gluteal regions), whereas android obesity (the apple shape) refers to central body distribution. Gynoid fat is more resistant to catecholamines and more sensitive to insulin than abdominal fat; thus, extraction and storage of fatty acids easily occur, and fat is accumulated more readily in the thighs and buttocks. This fat is associated with minimal fatty acid flux, and, therefore, the negative consequences of fatty acid metabolism are less. Gynoid fat is principally stored fat. The clinical meaning of all this is that women with gynoid obesity are less likely than women with android obesity to develop diabetes mellitus and coronary heart disease.<sup>185</sup>

During pregnancy, lipoprotein lipase activity increases in gynoid fat, further promoting fat storage and explaining the tendency for women to gain thigh and hip weight during pregnancy. Also, because this fat is more resistant to mobilization, it is harder to get rid of. This difficulty is related to the adrenergic receptor concentration in the fat cells, the regulation of which remains a mystery.

Android obesity refers to fat located in the abdominal wall and visceral-mesenteric locations. This fat is more sensitive to catecholamines and less sensitive to insulin and, thus, more active metabolically. It more easily delivers triglyceride to other tissues to meet energy requirements. This fat distribution is associated with hyperinsulinemia, impaired glucose tolerance, diabetes mellitus, an increase in androgen production rates, decreased levels of sex hormone-binding globulin, and increased levels of free testosterone and estradiol.<sup>186,187</sup> In addition, women with central obesity have decreased cortisol levels, a finding that would be consistent with increased leptin levels.<sup>188,189</sup> These metabolic changes improve with weight loss.<sup>189</sup>

It is central body obesity that is associated with cardiovascular risk factors, including hypertension and adverse cholesterol-lipoprotein profiles.<sup>190</sup> The waist/hip ratio is a variable strongly and inversely associated with the level of HDL<sub>2</sub>, the fraction of HDL cholesterol most consistently linked with protection from cardiovascular disease.<sup>191</sup> The adverse impact of excess weight in adolescence can be explained by the fact that deposition of fat in adolescence is largely central in location.<sup>18,192</sup> Weight loss in women with lower body obesity is mainly cosmetic, whereas loss of central body weight is more important for general health in that an improvement in cardiovascular risk is associated with loss of central body fat. At any given level of BMI, an increase in central, android fat increases the risk of cardiovascular disease.

# Estimating Central Body Obesity

The waist/hip ratio is a means of estimating the degree of upper to lower body obesity; the ratio accurately predicts the amount of intraabdominal fat (which is greater with android obesity).<sup>193,194</sup> However, studies have demonstrated that the more easily determined circumference of the waist, measured just above the hip bones at end of expiration, is a better predictor of central, android abdominal fat.<sup>195,196</sup> **A waist circumference greater than 102 cm (about 40 inches) in men and 88 cm (about 35 inches) in women is predictive of abnormal endocrinologic and metabolic function and is associated with a major increase in risk of cardiovascular and metabolic diseases.**<sup>195</sup> The risk begins to increase at threshold measurements of 94 cm for men and 80 cm for women.<sup>197,198</sup>

# MANAGEMENT OF OBESITY

---

In addition to not smoking cigarettes, weight reduction is the most important health measure available for reducing the risk of cardiovascular disease. After adjusting for age and smoking, the Nurses' Health Study documented a threefold increase in risk for coronary disease among women with a BMI of 29 or greater.<sup>199</sup> Even women who are mildly or moderately overweight have a substantial increase in coronary risk. In the Nurses' Health Study, 40% of coronary events could be attributed to excessive body weight, and in the heaviest women, 70%. But most importantly, weight loss is followed by a decrease in mortality from all causes, and, especially, a decrease in cardiovascular and cancer mortality.<sup>200</sup>

For most patients, after a routine evaluation to rule out pathology such as diabetes mellitus, the clinician is left with the frustrating task of prescribing a diet. But it is not enough to just prescribe a diet or prescribe an anorexic drug. An effective weight loss program requires commitment from both patient and clinician.

Clinician and patient should agree on the goal of a diet program. Although the clinician may want the patient to reach ideal weight, the patient may be satisfied with less. Motivation is improved when the goals meet both personal and medical objectives. It is realistic to lose 4–5 lb in the 1st month and 20–30 lb in 4–5 months. To achieve a respectable rate of weight loss, intake must be 500–1,000 calories below energy expenditure.<sup>201</sup> But as weight is lost, energy requirements decrease; therefore, unless energy intake decreases, the rate of weight loss will slow. Clinicians and patients need to establish reasonable goals, and only modest changes in diet and activity are necessary.

Despite various fads and diet books, the best diet continues to be a limitation of calories to between 900 and 1,200 calories/day, the actual amount depending on what the individual patient will accept and pursue. When energy intake is less than this, it is very difficult to obtain the recommended levels of vitamins and minerals. A daily vitamin and mineral supplement should be used with very low calorie diets. Randomized, controlled trials concluded that the low-carbohydrate, high-protein, high-fat diet produced a greater weight loss (only a 4-kg difference) in the first 6 months, but after a year, there was no difference compared to a conventional low-calorie, low-fat diet.<sup>202,203</sup> The low-carbohydrate diets produce ketosis, causing significant halitosis.

Ideal diet:

- Carbohydrates—50%
- Protein—15–20%
- Fat—less than 30%

The discouraging aspect is that to lose a pound of fat, the equivalent to a 3,500-calorie intake must be expended. Dieting has to be slow and steady to be effective. Successful programs include behavior modification, frequent visits to the clinician, and involvement of family members. Behavior modification starts with daily recording of activity and behavior related to food intake, followed by the elimination of inappropriate cues (other than hunger) that lead to eating.

Careful studies (performed in hospitalized subjects on metabolic wards) have indicated that the carbohydrate and fat composition of the diet has no effect on the rate of weight loss.<sup>204</sup> Restriction of calories remains the important principle, recognizing that reduction in fat intake is the most effective method of weight loss. The protein-sparing modified fast is a ketogenic regimen providing approximately 800 calories/day. Unsupplemented liquid protein diets have been associated with deaths due to cardiac arrhythmias. The low-calorie diets that use protein and carbohydrate supplemented with minerals and vitamins as the sole source of nutrition are safer but should be used only for severe obesity and under medical supervision.<sup>205</sup> These diets are still potentially dangerous. The other disadvantage to the semistarvation diet is that short-term success does not guarantee long-term weight maintenance. It is reported that at best only one-fourth to one-third of individuals who lose weight by a semistarvation ketogenic regimen plus behavior modification therapy have significant long-term weight reduction.<sup>206</sup> On the other hand, for that one-fourth to one-third, this represents a major accomplishment and is worth doing. Unfortunately, repeated dieting and recidivism have a negative impact. With each episode, the body learns to become more efficient, so that with each diet, weight comes off more slowly and is regained more rapidly.

It is not unusual to encounter patients who claim to be unable to lose weight despite following a diet with less than 1,200 calories/day. In a study of such patients, it was discovered that underreporting of actual food intake and overreporting of physical activity are both common.<sup>207</sup> While it may not be true for all patients, certainly some individuals do eat more than they think and exercise less than they report to their clinicians. This is not a deliberate conscious attempt to deceive the clinician. These patients truly believe that their resistance to weight loss is genetic and not due to their own personal behavior. They are astonished and distressed to learn the results of accurate recording of dietary intake and physical exercise. The help of a dietitian in recording a typical week's worth of eating and exercise is worthwhile. This kind of knowledge proves to be a powerful lever in providing the motivation to make the changes in lifestyle that can yield loss of weight.

Although most efforts yield short-term success, maintenance of weight loss is uncommon. Commercial organizations are no more successful than physician-directed programs or nonprofit self-help groups.<sup>208,209</sup> However, randomized trials demonstrated

that commercial programs or weight loss medications that include group support and lifestyle changes are more effective, achieving modest but clinically significant improvements.<sup>210,211,212,213,214</sup> Approximately 90–95% of people who lose weight subsequently regain it.<sup>134</sup> Thus, it is obvious why gimmicks abound in this area of patient management. A more reasonable attitude is to emphasize how much can be gained with only a little weight loss. A weight loss of 5–10% of body weight produces beneficial effects on the risks of cardiovascular disease and diabetes mellitus.<sup>200,215</sup> Compliance and caloric intake are more important than the specific dietary composition or reputation. In the U.S. Diabetes Prevention Program randomized clinical trial, intensive lifestyle interventions were more effective than prophylactic metformin treatment in reducing the incidence of diabetes.<sup>216</sup> Ten years after the initiation of the trial, the cumulative incidence of diabetes was reduced by 34% by lifestyle interventions and 18% in the metformin group.<sup>217</sup> These data demonstrate that there are substantial numbers of overweight individuals who can sustain long-term weight reduction when effective support and guidance are provided.

Unfortunately, smoking cessation is associated with an increase in being overweight.<sup>218</sup> And, of course, the link between smoking and weight control is exploited by the tobacco industry in its advertising. This should only increase the importance of our efforts to keep young people from starting smoking and to educate middle aged people regarding the dangers of smoking (Table 19.2).

## **TABLE 19.2 Weight Loss Drugs**

*Sympathomimetic Noradrenergic Agents (Amphetamine-Related Drugs)*

Diethylpropion (Tenuate)	25 mg before meals; 75 mg slow release form in morning
Phendimetrazine (Bontril)	35 mg before meals; 105 mg slow release form daily
Benzphetamine (Didrex)	25–50 mg 1–3 times daily
Phentermine (Adipex-P, Suprenza)	8 mg before meals; 15 or 37.5 mg in morning
Phentermine and Topiramate (Qsymia)	7.5 mg/46 mg once daily PO
<i>Lipase Inhibitor</i>	
Orlistat (Xenical)	120 mg t.i.d.
<i>Glucagon-like peptide-1 (GLP-1) analog</i>	
Liraglutide (Saxenda)	3 mg daily SC injection
<i>Combination of norepinephrine-dopamine reuptake inhibitor and nicotinic acetylcholine receptor antagonist (Bupropion) and opioid receptor antagonist (naltrexone)</i>	
Naltrexone-Bupropion (Contrave)	16 mg/180 mg b.i.d.
<i>Serotonin receptor (5HT-2C) agonist</i>	
Lorcaserin (Belviq)	10 mg b.i.d

Because of CNS and cardiovascular side effects (e.g., insomnia, nervousness, euphoria, hypertension, and tachycardia) and the lack of long-term data, the sympathomimetic noradrenergic agents should be reserved for short-term use (3 months or less) for individuals who wish to lose a small amount of weight. Tolerance and dependence are problems with continued use. Noradrenergic agents should not be used in individuals with cardiovascular disease. More recently, a combination of noradrenergic phentermine and an antiseizure agent topiramate has been approved for FDA for the long-term treatment of obesity. The effect of phentermine on chronic weight management is likely mediated by release of catecholamines in the hypothalamus, resulting in reduced appetite and decreased food consumption, but other metabolic effects may also be involved. The exact mechanism of action is not known. The precise mechanism of action of topiramate on chronic weight management is also not known. Topiramate's effect on chronic weight management may be due to its effects on both appetite suppression and satiety enhancement, induced by a combination of pharmacologic effects including augmenting the activity of the neurotransmitter gamma-aminobutyrate, modulation of voltage-gated ion channels, inhibition of AMPA/kainite excitatory glutamate receptors, or inhibition of carbonic anhydrase.

In addition to phentermine-topiramate, a number of agents have been approved by FDA for long-term use in adults with obesity (BMI  $\geq$  30), or who are overweight (BMI  $\geq$  27) with at least one weight-related medical condition. Among these agents, Orlistat (120 mg t.i.d. with meals) has been in the market the longest and acts only within the



gastrointestinal tract, inhibiting pancreatic lipase and increasing fecal fat loss.<sup>219</sup> Orlistat is associated with annoying gastrointestinal side effects (increased flatulence, cramps, and defecation of oily stools). There is some loss of the fat-soluble vitamins, and a vitamin supplement should be taken at bedtime.

Liraglutide is a glucagon-like peptide-1 (GLP-1) analogue and acts centrally to decrease appetite. It is effective in patients with type II diabetes and as a weight loss agent.<sup>220,221</sup> In addition to gastrointestinal side effect such as nausea, vomiting, and diarrhea that could result in severe dehydration, liraglutide may cause pancreatitis, cholecystitis, and hypoglycemia (especially in those using medications for IDDM). Lorcaserin is a selective 5-HT<sub>2C</sub> receptor agonist. The activation of 5-HT<sub>2C</sub> receptors in the hypothalamus is believed to activate POMC production and promote weight loss through satiety.<sup>222</sup> Despite initial concerns regarding safety (risk of tumors, heart valve issues) and efficacy, in 2012, the FDA officially approved lorcaserin for use in the treatment of obesity. In 2013, the US Drug Enforcement Administration classified lorcaserin as a Schedule IV drug under the Controlled Substances Act, because it has hallucinogenic properties at higher than approved doses and users could develop psychiatric dependencies on the drug. A combination of bupropion, a norepinephrine-dopamine reuptake inhibitor, and naltrexone, an opioid receptor antagonist, has also been approved by the FDA for long-term weight loss treatment.

A number of agents that have been used in the treatment of obesity within the past two decades are no longer available or utilized due to concerns regarding safety and efficacy. The popularity of the serotonergic agents received a setback with reports of increased risks due to high circulating levels of serotonin (even with short-term therapy) of the rare but life-threatening conditions of primary pulmonary hypertension and cardiac valvular disease, and two products, fenfluramine and dexfenfluramine, were withdrawn from the market.<sup>223,224,225</sup> Fluoxetine, a selective serotonin reuptake inhibitor (SSRI) commonly used as an antidepressant, produces only a short-term weight loss.<sup>226</sup> Indeed while acute therapy with fluoxetine is associated with modest weight loss, after remission of depressive symptoms, weight gain or loss for patients taking fluoxetine for longer periods is not different from that for patients taking placebo.<sup>227</sup> Sibutramine (Meridia), which suppresses appetite by blocking the neuronal uptake of both norepinephrine and serotonin, can cause hypertension and has been associated with increased cardiovascular events and strokes; it has been withdrawn from the market in several countries and regions including United States, European Union, and Australia.<sup>228</sup> Rimonabant, a cannabinoid receptor blocker that produces a modest weight loss was first approved in Europe in 2006 but was withdrawn worldwide in 2008 due to serious psychiatric side effects; it was never approved in the United States.<sup>229,230,231</sup>

A recent meta-analysis of 28 randomized clinical trials conducted among overweight and obese adults treated with FDA-approved long-term weight loss agents (orlistat, lorcaserin, naltrexone-bupropion, phentermine-topiramate, or liraglutide) for at least 1 year included 29,018 patients (74% women) with a median age 46 years; median baseline body weight, 100.5 kg; and median baseline BMI, 36.1.<sup>232</sup> A median 23% of placebo-treated participants had at least 5% weight loss compared to 75% taking phentermine-topiramate (OR, 9.22; 95% credible interval [CrI], 6.63–12.85), 63% taking liraglutide (OR, 5.54; 95% CrI, 4.16–7.78), 55% taking naltrexone-bupropion (OR, 3.96; 95% CrI, 3.03–5.11), 49% taking lorcaserin (OR, 3.10; 95% CrI, 2.38–4.05), and 44% taking orlistat (OR, 2.70; 95% CrI, 2.34–3.09).<sup>221</sup> All active agents were associated with significant excess weight loss compared with placebo at 1 year—phentermine-topiramate, 8.8 kg (95% CrI, –10.20 to –7.42 kg); liraglutide, 5.3 kg (95% CrI, –6.06 to –4.52 kg); naltrexone-bupropion, 5.0 kg (95% CrI, –5.94 to –3.96 kg); lorcaserin, 3.2 kg (95% CrI, –3.97 to –2.46 kg); and orlistat, 2.6 kg (95% CrI, –3.04 to –2.16 kg). Compared with placebo, liraglutide (OR, 2.95; 95% CrI, 2.11–4.23) and naltrexone-bupropion (OR, 2.64; 95% CrI, 2.10–3.35) were associated with the highest odds of adverse event–related treatment discontinuation. High attrition rates (30–45% in all trials) were associated with lower confidence in estimates.

Because weight is regained after discontinuing drug treatment, long-term therapy has been championed. However, very little information is available regarding the long-term use of appetite-suppressing drugs. Short-term studies indicate only a modest efficacy with variable responses.<sup>134,233</sup> Most of the weight loss occurs in the first 6 months and is limited to 5–10 kg (11–22 lb). Nevertheless, long-term treatment may enable some individuals to sustain weight loss and to more effectively make beneficial changes in diet and lifestyle. It is recommended that treatment with appetite-suppressing drugs should be limited to individuals who have failed to lose weight with conventional methods and who demonstrate significant comorbidities, such as android obesity, coronary heart disease, insulin resistance, and hypertension.<sup>134</sup> **Attainment of a normal body weight is unlikely with drug treatment; however, a 5–10% weight loss will have an important beneficial impact on risk factors for disease.**<sup>134</sup> Nevertheless, lifestyle changes remain the most important and effective intervention for the treatment of obesity.

Surgical treatment and starvation should be reserved for patients who are morbidly obese. Both methods involve many potential problems and require close monitoring. Although there can be major complications, bariatric surgery, including laparoscopic procedures, produces a weight loss of 50–75% that is sustained for many years and is associated with a reversal of abnormal metabolic conditions in both adults and children with a reduction in mortality rate.<sup>234,235,236,237,238</sup>

Controlled studies have not demonstrated the effectiveness of thyroid preparations or human chorionic gonadotropin.<sup>239</sup> Indeed, adding thyroid hormone increases the loss of lean body mass rather than fat tissue. It is clear that adjunctive drug measures are not successful unless the patient is also motivated either to limit caloric intake or to increase the exercise level in what will be a lifelong battle.

A regular pattern of physical exercise reduces the risk of myocardial infarction in all people.<sup>240</sup> Both weight loss and increased physical activity lower the level of low density lipoprotein (LDL), and increase the level of high density lipoprotein (HDL).<sup>241</sup> A further benefit of strenuous or prolonged exercise is an inhibition of appetite that lasts many hours and that is associated with an increase in the resting metabolic rate for 2–48 hours. The optimal program includes, therefore, a 1-hour, **daily** period of exercise (of moderate intensity, such as brisk walking), but even 2 or 3 times per week can be effective.<sup>242</sup> A combination of diet and exercise is better than either alone, and those who exercise are more successful in maintaining weight loss.<sup>209,243,244</sup> The best time for exercise is before meals or about 2 hours after eating. Lifestyle changes (exercise, no smoking, healthy diet) lower the risk of coronary heart disease even in obese individuals<sup>245</sup> (Table 19.3).

## TABLE 19.3

<b>Activity</b>	<b>Calories/hour</b>
Sleeping	90
Office work	240
Walking	240
Golf	300
Housework	300
Bicycling	360
Swimming	360
Tennis	480
Bowling	510
Running slowly	750 (ca. 120/mile)
Cross country skiing	840
Running fast	960 (ca. 160/mile)

Unfortunately, one cannot burn up significant calories quickly; it takes 18 minutes of running or 2 hours of walking to compensate for the average hamburger.<sup>246</sup>

Most frustrating is the problem of some patients who limit caloric intake yet do not lose weight. In fact, as the weights of certain patients increase, the number of calories required to remain in equilibrium decreases, due to a combination of reduced activity and a change in metabolism, now known to be appropriate consequences of changes in

leptin levels. The Vermont study demonstrated that the normal person with induced obesity requires 2,700 calories to remain in equilibrium; spontaneously obese patients require only about 1,300 calories.<sup>247</sup> Others argue that virtually everyone can lose weight on a diet of 1,000 calories/day in that the maintenance requirement for a sedentary adult is about 1.5 times the resting metabolic rate (about 1,000–1,500 calories/day).<sup>248</sup> Nevertheless, an individual who has been overweight requires about 15% fewer calories to maintain weight than an individual who has never been obese.<sup>249</sup> The clinician must be careful to avoid a condemning or punitive attitude and understand that it is possible to significantly restrict caloric intake and not lose weight.

Patients struggle with frustration and despair unless the clinician can motivate them to increase physical activity. In all individuals, dieting is doomed to failure unless it is combined with physical exercise, but this is especially true in chronically obese patients. In other words, the lifestyle of an obese person must be changed to overcome the desire to be inactive (walk instead of riding). Only by significantly increasing caloric expenditure will the input-output equilibrium be disturbed. Unfortunately, only 25% of American adults are engaged in significant leisure time physical activity.<sup>11</sup>

The obese person feels trapped. Obesity leads to characteristic behavioral manifestations, including passive personality, frequent periods of depression, decreased self-respect, and a sense of being hopelessly overwhelmed by problems. But just as the endocrine and metabolic changes are secondary to obesity, many of the psychosocial attributes surrounding obesity are also secondary.

Maintenance of a newly gained lower weight requires constant preventive attention. Motivation to change and emotional support during the change are important. They can be provided by friends, relatives, clinicians, or self-help organizations. If the vicious circle of failed diets, resignation to fate, guilt, and shame can be broken, a more effective, happier person will emerge.

# REFERENCES

1. Prevalence of obesity among adults and youth: United States, 2015–2016, <https://www.cdc.gov/nchs/data/databriefs/db288.pdf>
2. **National Center for Health Statistics**, Health, United States, 2016: With Chartbook on Long-Term Trends in Health, National Center for Health Statistics, Hyattsville, 2017.
3. **Flegal KM, Kruszon-Moran D, Carroll MD, Fryar CD, Ogden CL**, Trends in obesity among adults in the United States, 2005 to 2014, *JAMA* 315:2284, 2016.
4. **Ogden C, Carroll MD, Lawman, HG, Fryar CD, Kruszon-Moran D, Kit BK, Flegal BM**, Trends in obesity among children and adolescents in the United States, 1988–1994 through 2013–2014, *JAMA* 315:2292, 2016.
5. **Fryar CD, Carroll MD, Ogden CL**, Prevalence of overweight, obesity, and extreme obesity among adults aged 20 and over: United States, 1960–1962 through 2011–2014, National Center for Health Statistics Data, Health E-Stats, July 2016.
6. **Fryar CD, Carroll MD, Ogden CL**, Prevalence of overweight and obesity among children and adolescents aged 2–19 years: United States, 1963–1965 through 2013–2014, National Center for Health Statistics Data, Health E-Stats, July 2016.
7. **Harlan WR, Landis JR, Flegal KM, Davis CS, Miller ME**, Secular trends in body mass in the United States, 1960–1980, *Am J Epidemiol* 128:1065, 1988.
8. **Kuczmarski RJ, Flegal KM, Campbell SM, Johnson CL**, Increasing prevalence of overweight among US adults. The National Health and Nutrition Examination Surveys, 1960 to 1991, *JAMA* 272:205, 1994.
9. **Prentice AM, Jebb SA**, Obesity in Britain: gluttony or sloth?, *Br Med J* 311: 437, 1995.
10. **Flegal KM, Carroll MD, Ogden CL, Johnson CL**, Prevalence and trends in obesity among US adults, 1999–2000, *JAMA* 288:1723, 2002.
11. **Centers for Disease Control and Prevention**, State Indicator Report on Physical Activity, 2010. U.S. Department of Health and Human Services, Atlanta, 2010.
12. **Ogden CL, Carroll MD, Curtin LR, Lamb MM, Flegal KM**, Prevalence of high body mass index in US children and adolescents, 2007–2008, *JAMA* 303:242, 2010.
13. **Adams KF, Schatzkin A, Harris TB, Kipnis V, Mouw T, Ballard-Barbash R, Hollenbeck A, Leitzmann MF**, Overweight, obesity, and mortality in a large prospective cohort of persons 50 to 71 years old, *N Engl J Med* 355:763, 2006.
14. **Manson JE, Willett WC, Stampfer MJ, Colditz GA, Hunter DJ, Hankinson SE, Hennekens CH, Speizer FE**, Body weight and mortality among women, *N Engl J Med* 333:677, 1995.
15. **Park YW, Zhu S, Palaniappan L, Heshka S, Carnethon MR, Heymsfield SB**, The metabolic syndrome: prevalence and associated risk factor findings in the US population from the Third National Health and Nutrition Examination Survey, 1988–1994, *Arch Intern Med* 163:427, 2003.
16. **Calle EE, Rodriguez C, Walker-Thurmond K, Thun MJ**, Overweight, obesity, and mortality from cancer in a prospectively studied cohort of U.S. adults, *N Engl J Med* 348:1625, 2003.
17. **Rehman AG, Tyson M, Egger M, Heller RF, Zwahlen M**, Body-mass index and incidence of cancer: a systematic review and meta-analysis of prospective observational studies, *Lancet* 371:569, 2008.
18. **Must A, Jacques PF, Dallal GE, Bajema CJ, Dietz WH**, Long-term morbidity and mortality of overweight adolescents: a follow-up of the Harvard Growth Study of 1922 to 1935, *N Engl J Med* 327:1350, 1992.
19. **Peeters A, Barendregt JJ, Willekens F, Mackenbach JP, Al Mamun A, Bonneux L; for NEDCOM, the Netherlands Epidemiology and Demography, Compression of Morbidity Research Group**, Obesity in adulthood and its consequences for life expectancy: a life-table analysis, *Ann Intern Med* 138:24, 2003.
20. **Stewart ST, Cutler DM, Rosen AB**, Forecasting the effects of obesity and smoking on U.S. life expectancy, *N Engl J Med* 361:2252, 2009.
21. **Ravussin E, Swinburn BA**, Pathophysiology of obesity, *Lancet* 340:404, 1992.

22. **Thomas AE, McKay DA, Cutlip MB**, A nomograph method for assessing body weight, *Am J Clin Nutr* 29:302, 1976.
23. **Prospective Studies Collaboration; Whitlock G, Lewington S, Sherliker P, Clarke RB, Emberson J, Halsey J, Qizilbash N, Collins R, Peto R**, Body-mass index and cause-specific mortality in 900,000 adults: collaborative analyses of 57 prospective studies, *Lancet* 373:1083, 2009.
24. **Field AE, Coakley EH, Must A, Spadano JL, Laird N, Dietz WH, Rimm E, Colditz GA**, Impact of overweight on the risk of developing common chronic diseases during a 10-year period, *Arch Intern Med* 161:1581, 2001.
25. **Colditz GA, Willett WC, Rotnitzky A, Manson JE**, Weight gain as a risk factor for clinical diabetes mellitus in women, *Ann Intern Med* 122:481, 1995.
26. **Willett WC, Manson JE, Stampfer MJ, Colditz GA, Rosner B, Speizer FE, Hennekens CH**, Weight change and coronary heart disease in women: risk within the "normal" range, *JAMA* 273:461, 1995.
27. **Ferraro R, Lillioja S, Fontvieille A-M, Rising R, Bogardus C, Ravussin E**, Lower sedentary metabolic rate in women compared with men, *J Clin Invest* 90:780, 1992.
28. **Fukagawa NA, Bandini LG, Young JB**, Effect of age on body composition and resting metabolic rate, *Am J Physiol* 259:E233, 1990.
29. **Vaughan L, Zurlo F, Ravussin E**, Aging and energy expenditure, *Am J Clin Nutr* 53:821, 1991.
30. **Van Pelt RE, Jones PP, Davy KP, Desouza CA, Tanaka H, Davy BM, Seals DR**, Regular exercise and the age-related decline in resting metabolic rate in women, *J Clin Endocrinol Metab* 82:3208, 1997.
31. **Suter PM, Schutz Y, Jequier E**, The effect of ethanol on fat storage in healthy subjects, *N Engl J Med* 326:983, 1992.
32. **Fabry P, Hejda S, Cerny K**, Effects of meal frequency in school children. Changes in weight-height proportion and skinfold thickness, *Am J Clin Nutr* 18:358, 1966.
33. **Gold RM**, Hypothalamic obesity: the myth of the ventromedial nucleus, *Science* 182:488, 1973.
34. **Leibowitz SF**, Brain peptides and obesity: pharmacologic treatment, *Obes Res* 3(Suppl 4):573S, 1995.
35. **Wilber JF**, Neuropeptides, appetite regulation, and human obesity, *JAMA* 266:257, 1991.
36. **Sabatier N, Rowe I, Leng G**, Central release of oxytocin and the ventromedial hypothalamus, *Biochem Soc Trans* 35:1247, 2007.
37. **Kennedy GC**, The role of depot fat in the hypothalamic control of food intake in the rat, *Proc R Soc Lond B Biol Sci* 140:578, 1953.
38. **Hervey GR**, The effects of lesions in the hypothalamus in parabiotic rats, *J Physiol* 145:336, 1958.
39. **Zhang Y, Proenca R, Maffei M, Barone M, Leopold L, Friedman J**, Positional cloning of the mouse obese gene and its human homologue, *Nature* 372:425, 1994.
40. **Rossi J, Balthasar N, Olson D, Scott M, Berglund E, Lee CE, Choi MJ, Lauzon D, Lowell BB, Elmquist JK**, Melanocortin-4 receptors expressed by cholinergic neurons regulate energy balance and glucose homeostasis, *Cell Metab* 13(2): 195, 2011.
41. **Campfield LA, Smith FJ, Burn P**, The OB protein (leptin) pathway—a link between adipose tissue mass and central neural networks, *Horm Metab Res* 28:619, 1996.
42. **Tartaglia LA**, The leptin receptor, *J Biol Chem* 272:6093, 1997.
43. **Fan W, Boston BA, Kesterson RA, Hrubby VJ, Cone RD**, Role of melanocortineric neurons in feeding and the agouti obesity syndrome, *Nature* 385:165, 1997.
44. **Huszar D, Lynch CA, Fairchild-Huntress V, Dunmore JH, Fang Q, Berkemeier LR, Gu W, Kesterson RA, Boston BA, Cone RD, Smith FJ, Campfield LA, Burn P, Lee F**, Targeted disruption of the melanocortin-4 receptor results in obesity in mice, *Cell* 88(1):131, 1997.
45. **Krude H, Biebermann H, Luck W, Horn R, Brabant G, Gruters A**, Severe early-onset obesity, adrenal insufficiency and red hair pigmentation caused by POMC mutations in humans, *Nat Genet* 19:155, 1998.
46. **Yeo GS, Lank EJ, Farooqi IS, Keogh J, Challis BG, O'Rahilly S**, Mutations in the human melanocortin-4 receptor gene associated with severe familial obesity disrupts receptor function through multiple molecular mechanisms, *Hum Mol Genet* 12:561, 2003.
47. **Caro JF, Sinha MK, Kolaczynski JW, Zhang PL, Considine RV**, Leptin: the tale of an obesity gene,

Diabetes 45:1455, 1996.

48. **Stephens TW, Basinski M, Bristow PK, Bue-Valleskey JM, Burgett SG, Craft L, Hale J, Hoffman J, Hsiung HM, Kriauciunas A, et al.**, The role of neuropeptide Y in the antiobesity action of the obesity gene product, *Nature* 377:530, 1995.
49. **Mercer JG, Hoggard N, Williams LM, Lawrence CB, Hannah LT, Trayburn P**, Localization of leptin receptor mRNA and the long form splice variant (Ob-Rb) in mouse hypothalamus and adjacent brain regions by in situ hybridization, *FEBS Lett* 387:113, 1996.
50. **Devos R, Richards JG, Campfield LA, Tartaglia LA, Guisez Y, Van der Heyden J, Tavernier J, Plaetinck G, Burn P**, OB protein binds specifically to the chorioid plexus of mice and rats, *Proc Natl Acad Sci U S A* 93:5668, 1996.
51. **Cusin I, Rohner-Jeanrenaud F, Stricker-Krongrad A, Jeanrenaud B**, The weight-reducing effect of an intracerebroventricular bolus injection of leptin in genetically obese fa/fa rats. Reduced sensitivity compared with lean animals, *Diabetes* 45:1446, 1996.
52. **Muccioli G, Tschöp M, Papotti M, Deghenghi R, Hieman M, Ghigo E**, Neuroendocrine and peripheral activities of ghrelin: implications in metabolism and obesity, *Eur J Pharmacol* 440:235, 2002.
53. **Tena-Sempere M**, Ghrelin as a pleiotrophic modulator of gonadal function and reproduction, *Nat Clin Pract* 4:666, 2008.
54. **Fernández-Fernández R, Tena-Sempere M, Navarro VM, Barreiro ML, Castellano JM, Aguilar E, Pinilla L**, Effects of ghrelin upon gonadotropin-releasing hormone and gonadotropin secretion in adult female rats: in vivo and in vitro studies, *Neuroendocrinology* 82(5–6):245, 2005.
55. **Müller TD, Nogueiras R, Andermann ML, Andrews ZB, Anker SD, Argente J, Batterham RL, Benoît SC, Bowers CY, Broglio F, Casanueva FF, D'Alessio D, Depoortere I, Geliebter A, Ghigo E, Cole PA, Cowley M, Cummings DE, Dagher A, Diano S, Dickson SL, Diéguez C, Granata R, Grill HJ, Grove K, Habegger KM, Heppner K, Heiman ML, Holsen L, Holst B, Inui A, Jansson JO, Kirchner H, Korbonits M, Laferrère B, LeRoux CW, Lopez M, Morin S, Nakazato M, Nass R, Perez-Tilve D, Pfluger PT, Schwartz TW, Seeley RJ, Sleeman M, Sun Y, Sussel L, Tong J, Thorner MO, van der Lely AJ, van der Ploeg LH, Zigman JM, Kojima M, Kangawa K, Smith RG, Horvath T, Tschöp MH**, Ghrelin, *Mol Metab* 21:437, 2015.
56. **Kojima M, Hosoda H, Date Y, Nakazato M, Matsuo H, Kangawa K**, Ghrelin is a growth hormone-releasing acylated peptide from stomach, *Nature* 402:656, 1999.
57. **Arvat E, Maccario M, Di Vito L, Broglio F, Benso kA, Gottero C, Papotti M, Muccioli G, Dieguez C, Casanueva FF, Deghenghi R, Camanni F, Ghigo E**, Endocrine activities of ghrelin, a natural growth hormone secretagogue (GHS) in humans: comparison and interactions with hexarelin, a nonnatural peptidyl GHS and GH-releasing hormone, *J Clin Endocrinol Metab* 86:1169, 2001.
58. **Batterham RL, Cohen MA, Ellis SM, Le Roux CW, Withers DJ, Frost GS, Gbatei MA, Bloom SR**, Inhibition of food intake in obese subjects by peptide YY3–36, *N Engl J Med* 349:941, 2003.
59. **Wren AM, Seal IJ, Cohen MA, Brynes AE, Frost GS, Murphy KG, Dhillo WS, Gbatei MA, Bloom SR**, Ghrelin enhances appetite and increases food intake in humans, *J Clin Endocrinol Metab* 86:5992, 2001.
60. **Neary NM, Small CJ, Wren AM, Lee JL, Druce MR, Palmieri C, Frost GS, Gbatei MA, Coombes RC, Bloom SR**, Ghrelin increases energy intake in cancer patients with impaired appetite: acute, randomized, placebo-controlled trial, *J Clin Endocrinol Metab* 89:2832, 2004.
61. **Miljic D, Pekic S, Djurovic M, Doknic M, Milic N, Casanueva FF, Gbatei M, Popovic V**, Ghrelin has partial or no effect on appetite, growth hormone, prolactin and cortisol release in patients with anorexia nervosa, *J Clin Endocrinol Metab* 91:1491, 2006.
62. **Tena-Sempere M**, Roles of ghrelin and leptin in the control of reproductive function, *Neuroendocrinology* 86:229, 2007.
63. **Dietrich MO, Horvath TL**, Feeding signals and brain circuitry, *Eur J Neurosci* 30(9):1688, 2009.
64. **Broberger C, Johansen J, Johansson C, Schalling M, Hokfelt T**, The neuropeptide Y/agouti gene-related protein (AGRP) brain circuitry in normal, anorectic, and monosodium glutamate-treated mice, *Proc Natl Acad Sci U S A* 95(25):15043, 1998.



65. **Horvath TL, Bechmann I, Naftolin F, Kalra SP, Leranth C**, Heterogeneity in the neuropeptide Y-containing neurons of the rat arcuate nucleus: GABAergic and non-GABAergic subpopulations, *Brain Res* 756(1–2):283, 1997.
66. **Ollmann MM, Wilson BD, Yang YK, Kerns JA, Chen Y, Gantz I, Barsh GS**, Antagonism of central melanocortin receptors in vitro and in vivo by agouti-related protein, *Science (New York, NY)* 278(5335):135, 1997.
67. **Chen HY, Trumbauer ME, Chen AS, Weingarth DT, Adams JR, Frazier EG, Shen Z, Marsh DJ, Feighner SD, Guan XM, Ye Z, Nargund RP, Smith RG, Van der Ploeg LH, Howard AD, MacNeil DJ, Qian S**, Orexigenic action of peripheral ghrelin is mediated by neuropeptide Y and agouti-related protein, *Endocrinology* 145(6):2607, 2004.
68. **Clark JT, Kalra PS, Crowley WR, Kalra SP**, Neuropeptide Y and human pancreatic polypeptide stimulate feeding behavior in rats, *Endocrinology* 115(1):427, 1984.
69. **Zarjevski N, Cusin I, Vettor R, Rohner-Jeanrenaud F, Jeanrenaud B**, Chronic intracerebroventricular neuropeptide-Y administration to normal rats mimics hormonal and metabolic changes of obesity, *Endocrinology* 133(4):1753, 1993.
70. **Schwartz MW, Seeley RJ**, The new biology of body weight regulation, *J Am Diet Assoc* 97:54, 1997.
71. **Bäckberg M, Madjid N, Ogren SO, Meister B**, Down-regulated expression of agouti-related protein (AGRP) mRNA in the hypothalamic arcuate nucleus of hyperphagic and obese tub/tub mice, *Mol Brain Res* 125:129, 2004.
72. **Shutter JR, Graham M, Kinsey AC, Scully S, Lüthy R, Stark KL**, Hypothalamic expression of ART, a novel gene related to agouti, is up-regulated in obese and diabetic mutant mice, *Genes Dev* 11(5):593, 1997.
73. **Ollmann MM, Wilson BD, Yang YK, Kerns JA, Chen Y, Gantz I, Barsh GS**, Antagonism of central melanocortin receptors in vitro and in vivo by agouti-related protein, *Science* 278:135, 1997.
74. **Hahn TM, Breininger JF, Baskin DG, Schwartz MW**, Coexpression of Agrp and NPY in fasting-activated hypothalamic neurons, *Nat Neurosci* 1(4):271, 1998.
75. **Kohno D, Sone H, Minokoshi Y, Yada T**, Ghrelin raises  $[Ca^{2+}]_i$  via AMPK in hypothalamic arcuate nucleus NPY neurons, *Biochem Biophys Res Commun* 366(2):388, 2008.
76. **Sternson SM, Shepherd GM, Friedman JM**, Topographic mapping of VMH → arcuate nucleus microcircuits and their reorganization by fasting, *Nat Neurosci* 8(10):1356, 2005.
77. **Takahashi KA, Cone RD**, Fasting induces a large, leptin-dependent increase in the intrinsic action potential frequency of orexigenic arcuate nucleus neuropeptide Y/Agouti-related protein neurons, *Endocrinology* 146(3):1043, 2005.
78. **Yang Y, Atasoy D, Su HH, Sternson SM**, Hunger states switch a flip-flop memory circuit via a synaptic AMPK-dependent positive feedback loop, *Cell* 146(6):992, 2011.
79. **Fioramonti X, Contie S, Song Z, Routh VH, Lorsignol A, Penicaud L**, Characterization of glucosensing neuron subpopulations in the arcuate nucleus: integration in neuropeptide Y and pro-opio melanocortin networks? *Diabetes* 56(5):1219, 2007.
80. **Enriori PJ, Evans AE, Sinnayah P, Jobst EE, Tonelli-Lemos L, Billes SK, Glavas MM, Grayson BE, Perello M, Nillni EA, Grove KL, Cowley MA**, Diet-induced obesity causes severe but reversible leptin resistance in arcuate melanocortin neurons, *Cell Metab* 5:181, 2007.
81. **Creemers JW, Pritchard LE, Gyte A, Le Rouzic P, Meulemans S, Wardlaw SL, Zhu X, Steiner DF, Davies N, Armstrong D, Lawrence CB, Luckman SM, Schmitz CA, Davies RA, Brennand JC, White A**, Agouti-related protein is posttranslationally cleaved by proprotein convertase 1 to generate agouti-related protein (AGRP)83-132: interaction between AGRP83-132 and melanocortin receptors cannot be influenced by syndecan-3, *Endocrinology* 147:1621, 2006.
82. **Aponte Y, Atasoy D, Sternson SM**, AGRP neurons are sufficient to orchestrate feeding behavior rapidly and without training, *Nat Neurosci* 14(3):351, 2011.
83. **Cone RD**, Anatomy and regulation of the central melanocortin system, *Nat Neurosci* 8(5):571, 2005.
84. **Ibrahim N, Bosch MA, Smart JL, Qiu J, Rubinstein M, Ronnekleiv OK, Low MJ, Kelly MJ**, Hypothalamic proopiomelanocortin neurons are glucose responsive and express K(ATP) channels,

Endocrinology 144(4):1331, 2003.

85. **Parton LE, Ye CP, Coppari R, Enriori PJ, Choi B, Zhang CY, Xu C, Vianna CR, Balthasar N, Lee CE, Elmquist JK, Cowley MA, Lowell BB**, Glucose sensing by POMC neurons regulates glucose homeostasis and is impaired in obesity, *Nature* 449(7159):228, 2007.
86. **Wang R, Liu X, Hentges ST, Dunn-Meynell AA, Levin BE, Wang W, Routh VH**, The regulation of glucose-excited neurons in the hypothalamic arcuate nucleus by glucose and feeding-relevant peptides, *Diabetes* 53(8):1959, 2004.
87. **Cowley MA, Smart JL, Rubinstein M, Cerdan MG, Diano S, Horvath TL, Cone RD, Low MJ**, Leptin activates anorexigenic POMC neurons through a neural network in the arcuate nucleus, *Nature* 411(6836):480, 2001.
88. **Elias CF, Aschkenasi C, Lee C, Kelly J, Ahima RS, Bjorbaek C, Flier JS, Saper CB, Elmquist JK**, Leptin differentially regulates NPY and POMC neurons projecting to the lateral hypothalamic area, *Neuron* 23(4):775, 1999.
89. **Krashes MJ, Koda S, Ye C, Rogan SC, Adams AC, Cusher DS, Maratos-Flier E, Roth BL, Lowell BB**, Rapid, reversible activation of AgRP neurons drives feeding behavior in mice, *J Clin Invest* 121(4):1424, 2011.
90. **Dietrich MO, Antunes C, Geliang G, Liu ZW, Borok E, Nie Y, Xu AW, Souza DO, Gao Q, Diano S, Gao XB, Horvath TL**, Agrp neurons mediate Sirt1's action on the melanocortin system and energy balance: roles for Sirt1 in neuronal firing and synaptic plasticity, *J Neurosci* 30(35):11815, 2010.
91. **Tong Q, Ye CP, Jones JE, Elmquist JK, Lowell BB**, Synaptic release of GABA by AgRP neurons is required for normal regulation of energy balance, *Nat Neurosci* 11(9):998, 2008.
92. **Wu Q, Howell MP, Cowley MA, Palmiter RD**, Starvation after AgRP neuron ablation is independent of melanocortin signaling, *Proc Natl Acad Sci U S A* 105(7):2687, 2008.
93. **Atasoy D, Betley JN, Su HH, Sternson SM**, Deconstruction of a neural circuit for hunger, *Nature* 488(7410):172, 2012.
94. **Horvath TL, Naftolin F, Kalra SP, Leranth C**, Neuropeptide-Y innervation of beta-endorphin-containing cells in the rat mediobasal hypothalamus: a light and electron microscopic double immunostaining analysis, *Endocrinology*, 131(5):2461, 1992.
95. **Wu Q, Howell MP, Palmiter RD**, Ablation of neurons expressing agouti-related protein activates fos and gliosis in postsynaptic target regions, *J Neurosci* 28(37):9218, 2008.
96. **Halaas JL, Gajiwala KS, Maffei M, Cohen SL, Chait BT, Rabinowitz D, Lallone RL, Burley SK, Friedman JM**, Weight-reducing effects of the plasma protein encoded by the obese gene, *Science (New York, NY)* 269(5223): 543, 1995.
97. **van den Top M, Lee K, Whyment AD, Blanks AM, Spanswick D**, Orexigen-sensitive NPY/AgRP pacemaker neurons in the hypothalamic arcuate nucleus, *Nat Neurosci* 7(5):493, 2004.
98. **Pinto S, Roseberry AG, Liu H, Diano S, Shanabrough M, Cai X, Friedman JM, Horvath TL**, Rapid rewiring of arcuate nucleus feeding circuits by leptin, *Science* 304:110, 2004.
99. **Schwartz MW, Baskin DG, Bukowski TR, Kuijper JL, Foster D, Lasser G, Prunkard DE, Porte D, Woods SC, Seeley RJ, Weigle DS**, Specificity of leptin action on elevated blood glucose levels and hypothalamic neuropeptide Y gene expression in ob/ob mice, *Diabetes* 45:531, 1996.
100. **Wiegler DS, Duell PB, Connor WE, Steiner RA, Soules MR, Kuijper JL**, Effect of fasting, refeeding, and dietary fat restriction on plasma leptin levels, *J Clin Endocrinol Metab* 82:561, 1997.
101. **Rohner-Jeanraud F**, A neuroendocrine reappraisal of the dual-centre hypothesis: its implications for obesity and insulin resistance, *Int J Obes Relat Metab Disord* 19:517, 1995.
102. **Cowley MA, Smith RG, Diano S, Tschöp M, Pronchuk N, Grove KL, Strasburger CJ, Bidlingmaier M, Esterman M, Heiman ML, Garcia-Segura LM, Nilni EA, Mendez P, Low MJ, Sotonyi P, Friedman JM, Liu H, Pinto S, Colmers WF, Cone RD, Horvath TL**, The distribution and mechanism of action of ghrelin in the CNS demonstrates a novel hypothalamic circuit regulating energy homeostasis, *Neuron* 37(4):649, 2003.
103. **Andrews ZB, Liu ZW, Wallingford N, Erion DM, Borok E, Friedman JM, Tschöp MH, Shanabrough**

- M, Cline G, Shulman GI, Coppola A, Gao XB, Horvath TL, Diano S**, UCP2 mediates ghrelin's action on NPY/AgRP neurons by lowering free radicals, *Nature* 454:846, 2008.
104. **Spanwick D, Smith MA, Mirshamsi S, Routh VH, Ashford ML**, Insulin activates ATP-sensitive K<sup>+</sup> channels in hypothalamic neurons of lean, but not obese rats, *Nat Neurosci* 3(8):757, 2000.
  105. **Yaswen L, Diehl N, Brennan MB, Hochgeschwender U**, Obesity in the mouse model of pro-opiomelanocortin deficiency responds to peripheral melanocortin, *Nat Med* 5(9):1066, 1999.
  106. **Balthasar N, Dalgaard LT, Lee CE, Yu J, Funahashi H, Williams T, Ferreira M, Tang V, McGovern RA, Kenny CD, Christiansen LM, Edelstein E, Choi B, Boss O, Aschkenasi C, Zhang CY, Mountjoy K, Kishi T, Elmquist JK, Lowell BB**, Divergence of melanocortin pathways in the control of food intake and energy expenditure, *Cell* 123(3):493, 2005.
  107. **Sutton GM, Trevaskis JL, Hulver MW, McMillan RP, Markward NJ, Babin MJ, Meyer EA, Butler AA**, Diet-genotype interactions in the development of the obese, insulin-resistant phenotype of C57BL/6J mice lacking melanocortin-3 or -4 receptors, *Endocrinology* 147(5):2183, 2006.
  108. **Butler AA, Kesterson RA, Khong K, Cullen MJ, Pelleymounter MA, Dekoning J, Baetscher M, Cone RD**, A unique metabolic syndrome causes obesity in the melanocortin-3 receptor-deficient mouse, *Endocrinology* 141(9):3518, 2000.
  109. **Erickson JC, Clegg KE, Palmiter RD**, Sensitivity to leptin and susceptibility to seizures of mice lacking neuropeptide Y, *Nature* 381(6581):415, 1996.
  110. **Qian S, Chen H, Weingarth D, Trumbauer ME, Novi DE, Guan X, Yu H, Shen Z, Feng Y, Frazier E, Chen A, Camacho RE, Shearman LP, Gopal-Truter S, MacNeil DJ, Van der Ploeg LH, Marsh DJ**, Neither agouti-related protein nor neuropeptide Y is critically required for the regulation of energy homeostasis in mice, *Mol Cell Biol* 22(14):5027, 2002.
  111. **Luquet S, Perez FA, Hnasko TS, Palmiter RD**, NPY/AgRP neurons are essential for feeding in adult mice but can be ablated in neonates, *Science (New York, NY)* 310(5748):683, 2005.
  112. **Wu Q, Boyle MP, Palmiter RD**, Loss of GABAergic signaling by AgRP neurons to the parabrachial nucleus leads to starvation, *Cell* 137(7):1225, 2009.
  113. **Ingalls AM, Dickie MM, Snell GD**, Obese, a new mutation in the house mouse, *Obes Res* 4(1):101, 1996.
  114. **Cohen P, Zhao C, Cai X, Montez JM, Rohani SC, Feinstein P, Mombaerts P, Friedman JM**, Selective deletion of leptin receptor in neurons leads to obesity, *J Clin Invest* 108(8):1113, 2001.
  115. **McMinn JE, Liu SM, Dragatsis I, Dietrich P, Ludwig T, Eiden S, Chua SC Jr**, An allelic series for the leptin receptor gene generated by CRE and FLP recombinase, *Mamm Genome* 15(9):677, 2004.
  116. **Dezaki K, Sone H, Koizumi M, Nakata M, Kakei M, Nagai H, Hosoda H, Kangawa K, Yada T**, Blockade of pancreatic islet-derived ghrelin enhances insulin secretion to prevent high-fat diet-induced glucose intolerance, *Diabetes* 55(12):3486, 2006.
  117. **Wortley KE, Anderson KD, Garcia K, Murray JD, Malinova L, Liu R, Moncrieffe M, Thabet K, Cox HJ, Yancopoulos GD, Wiegand SJ, Sleeman MW**, Genetic deletion of ghrelin does not decrease food intake but influences metabolic fuel preference, *Proc Natl Acad Sci U S A* 101(21):8227, 2004.
  118. **Saladin R, Staels B, Auwerx J, Briggs M**, Regulation of ob gene expression in rodents and humans, *Horm Metab Res* 28:638, 1996.
  119. **Kolaczynski JW, Ohannesian J, Considine RV, Marco CC, Caro JF**, Response of leptin to short-term and prolonged overfeeding in humans, *J Clin Endocrinol Metab* 81:4162, 1996.
  120. **Malmstrom R, Taskinen MR, Karonen SL, Ykijarvinen H**, Insulin increases plasma leptin concentrations in normals and patients with NIDDM, *Diabetologia* 39:993, 1996.
  121. **Kolaczynski JW, Nyce MR, Considine RV, Boden G, Nolan JJ, Henry R, Mudaliar SR, Olefsky J, Caro JF**, Acute and chronic effect of insulin on leptin production in humans: studies in vivo and in vitro, *Diabetes* 45:699, 1996.
  122. **Schwartz MW, Seeley RJ**, Neuroendocrine responses to starvation and weight loss, *N Engl J Med* 336:1802, 1997.
  123. **Considine RV, Sinha MK, Heiman ML, Krauciunas A, Stephens TW, Nyce MR, Ohannesian JP, Marco CC, McKee LJ, Bauer TL, Caro JF**, Serum immunoreactive-leptin concentrations in normal-weight

and obese humans, *N Engl J Med* 334:292, 1995.

124. **Lonnqvist F, Arner P, Norfors L, Schalling M**, Overexpression of the obese (ob) gene in adipose tissue of human obese subjects, *Nat Med* 9:950, 1995.
125. **Hamilton B, Paglia D, Kwan A, Deitel M**, Increased obese mRNA expression in omental fat cells from massively obese humans, *Nat Med* 9:953, 1995.
126. **Kennedy A, Gettys TW, Watson P, Wallace P, Ganaway E, Pan Q, Garvey WT**, The metabolic significance of leptin in humans: gender-based differences in relationship to adiposity, insulin sensitivity, and energy expenditure, *J Clin Endocrinol Metab* 82:1293, 1997.
127. **Saad MF, Damani S, Gingerich RL, Riad-Gabriel MG, Khan A, Boyadjian R, Jinagouda SD, El-Tawil K, Rude RK, Kamdar V**, Sexual dimorphism in plasma leptin concentration, *J Clin Endocrinol Metab* 82:579, 1997.
128. **Nicklas BJ, Toth MJ, Goldberg AP, Poehlman ET**, Racial differences in plasma leptin concentrations in obese postmenopausal women, *J Clin Endocrinol Metab* 82:315, 1997.
129. **Considine RV, Considine EL, Williams CJ, Nyce MR, Zhang PL, Opentanova I, Ohannesian JP, Koaczynski JW, Bauer TL, Moore JH, Caro JF**, Mutation screening and identification of a sequence variation in the human Ob gene coding, *Biochem Biophys Res Commun* 220:735, 1996.
130. **Schwartz MH, Peskind E, Raskind M, Boyko EJ, Porte D Jr**, Cerebrospinal fluid leptin levels: relationship to plasma levels and to adiposity in humans, *Nat Med* 2:589, 1996.
131. **Caro JF, Kolaczynski JW, Nyce MR, Ohannesian JP, Opentanova I, Goldman WH, Lynn RB, Zhang P-L, Sinha MK, Considine RV**, Decreased cerebrospinal-fluid/serum leptin ratio in obesity: a possible mechanism for leptin resistance, *Lancet* 348:159, 1996.
132. **Van Heek M, Compton DS, France CF, Tedesco RP, Fawzi AB, Graziano MP, Sybertz EJ, Strader CD, Davis HR Jr**, Diet-induced obese mice develop peripheral, but not central, resistance to leptin, *J Clin Invest* 99:385, 1997.
133. **Sinha MK, Opentanova I, Ohannesian JP, Kolaczynski JW, Heiman ML, Hale J, Becker GW, Bowsher RR, Stephens TW, Caro JF**, Evidence of free and bound leptin in human circulation. Studies in lean and obese subjects and during short-term fasting, *J Clin Invest* 98:1277, 1996.
134. **National Task Force on the Prevention and Treatment of Obesity**, Long-term pharmacotherapy in the management of obesity, *JAMA* 276:1907, 1996.
135. **Wing RR, Sinha MK, Considine RV, Lang W, Caro JF**, Relationship between weight loss maintenance and changes in serum leptin levels, *Horm Metab Res* 28:698, 1996.
136. **Saris WHM, Kempen KR, Campfield LA, Tenenbaum R**, Responses of plasma OB protein concentration to weight cycling in obese women, *Obes Res* 4(Suppl 1):40s, 1996.
137. **Considine RV, Considine EL, Williams CJ, Hyde TM, Caro JF**, The hypothalamic leptin receptor in humans: identification of incidental sequence polymorphisms and absence of the ob/ob mouse and fa/fa rat mutations, *Diabetes* 45:992, 1996.
138. **Montague CT, Farooqi IS, Whitehead JP, Soos MA, Rau H, Wareham NJ, Sewter CP, Digby JE, Mohammed SN, Hurst JA, Cheetham CH, Earley AR, Barnett AH, Prins JB, O'Rahilly SO**, Congenital leptin deficiency is associated with severe early-onset obesity in humans, *Nature* 387:903, 1997.
139. **Strobel A, Issad T, Camoin M, Ozata M, Strosberg AD**, A leptin mutation associated with hypogonadism and morbid obesity, *Nat Genet* 18:213, 1998.
140. **Mazen I, El-Gammal M, Abdel-Hamid M, Amr K**, A novel homozygous missense mutation of the leptin gene (N103K) in an obese Egyptian patient, *Mol Genet Metab* 97:305, 2009.
141. **Wang TN, Huang MC, Chang WT, Ko AM, Tsai EM, Liu CS, Lee CH, Ko YC**, G-2548A polymorphism of the leptin gene is correlated with extreme obesity in Taiwanese aborigines, *Obesity* 14:183, 2006.
142. **Jackson RS, Creemers JWM, Ohagi S, Raffin-Sanson ML, Sanders L, Montague CT, Hutton JC, O'Rahilly S**, Obesity and impaired prohormone processing associated with mutations in the human prohormone convertase 1 gene, *Nat Genet* 16:303, 1997.
143. **Chagnon YC, Perusse L, Lamothe M, Chagnon M, Nadeau A, Dionne FT, Gagnon J, Cheung WK, Leibel RL, Bouchard G**, Suggestive linkages between markers on human 1p32-p22 and body fat and insulin

levels in the Quebec Family Study, *Obes Res* 5:115, 1997.

144. **Calton MA, Ersoy BA, Zhang S, Kane JP, Malloy MJ, Pullinger CR, Bromberg Y, Pennacchio LA, Dent R, McPherson R, Ahituv N, Vaisee C**, Association of functionally significant Melanocortin-4 but not Melanocortin-3 receptor mutations with severe adult obesity in a large North American case-control study, *Hum Mol Genet* 18:1140, 2009.
145. **Wangensteen T, Kolsgaard ML, Mattingsdal M, Joner G, Tonstad S, Undlien D, Retterstol L**, Mutations in the melanocortin 4 receptor (MCR4) gene in obese patients in Norway, *Exp Clin Endocrinol Diabetes* 117:266, 2009.
146. **Reinehr T, Hebebrand J, Friedel S, Toschke AM, Brumm H, Biebermann H, Hinney A**, Lifestyle intervention in obese children with variations in the melanocortin 4 receptor gene, *Obesity* 17:382, 2009.
147. **Chehab FF, Mounzih K, Lu R, Lim ME**, Early onset of reproductive function in normal female mice treated with leptin, *Science* 275:88, 1997.
148. **Mantzoros CS, Flier JS, Rogol AD**, A longitudinal assessment of hormonal and physical alterations during normal puberty in boys. V. Rising leptin levels may signal the onset of puberty, *J Clin Endocrinol Metab* 82:1066, 1997.
149. **Suter KJ, Phol CR, Wilson ME**, Circulating concentrations of nocturnal leptin, growth hormone, and insulin-like growth factor-I increase before the onset of puberty in agonadal male monkeys: potential signals for the initiation of puberty, *J Clin Endocrinol Metab* 85:808, 2000.
150. **Holtkamp K, Herpertz-Dahlmann B, Mika C, Heer M, Heussen N, Fichter M, Herpertz S, Senf W, Blum WF, Schweiger U, Warnke A, Ballauff A, Remschmidt H, Hebebrand J**, Elevated physical activity and low leptin levels co-occur in patients with anorexia nervosa, *J Clin Endocrinol Metab* 88:5169, 2003.
151. **Farooqi IS, Jebb SA, Langmack G, Lawrence E, Cheetham CH, Prentice AM, Hughes IA, McCamish MA, O'Rahilly S**, Effects of recombinant leptin therapy in a child with congenital leptin deficiency, *N Engl J Med* 341:879, 1999.
152. **Rosenbaum M, Nicolson M, Hirsch J, Heymsfield SB, Gallagher D, Chu F, Leibel R**, Effects of gender, body composition, and menopause on plasma concentrations of leptin, *J Clin Endocrinol Metab* 81:3424, 1996.
153. **Hassink SG, Sheslow DV, de Lancey E, Opentanova I, Considine RV, Caro JF**, Serum leptin in children with obesity: relationship to gender and development, *Pediatrics* 98:201, 1996.
154. **Ahima RS, Prabakaran D, Mantzoros C, Ou D, Lowell B, Marzozos-Flier E, Flier J**, Role of leptin in the neuroendocrine response to fasting, *Nature* 382:250, 1996.
155. **Laughlin GA, Yen SSC**, Hypoleptinemia in women athletes: absence of a diurnal rhythm with amenorrhea, *J Clin Endocrinol Metab* 82:318, 1997.
156. **Kohrt WM, Landt M, Birge Jr SJ**, Serum leptin levels are reduced in response to exercise training, but not hormone replacement therapy in older women, *J Clin Endocrinol Metab* 81:3980, 1996.
157. **Laughlin GA, Yen SSC**, Serum leptin levels in women with polycystic ovary syndrome: the role of insulin resistance/hyperinsulinemia, *J Clin Endocrinol Metab* 82:1692, 1997.
158. **Mantzoros CS, Dunaif A, Flier JS**, Leptin concentrations in the polycystic ovary syndrome, *J Clin Endocrinol Metab* 82:1687, 1997.
159. **Rouru J, Anttila L, Koskinen P, Penttilä T-A, Irjala K, Huupponen R, Koulou M**, Serum leptin concentrations in women with polycystic ovary syndrome, *J Clin Endocrinol Metab* 82:1697, 1997.
160. **Sahin I, Serter R, Karakurt F, Demirbas B, Guler S, Culha C, Taskapan C, Aral Y**, Leptin levels increase during flutamide therapy in women with polycystic ovary syndrome, *Horm Res* 60:232, 2003.
161. **Nolan JJ, Olefsky JM, Nyce MR, Considine RV, Caro JF**, Effect of troglitazone on leptin production: studies in vitro and in human subjects, *Diabetes* 45:1276, 1996.
162. **Cioffi JA, Shafer AW, Zupancic TJ, Smith-Gbur J, Mikhail A, Platika D, Snodgrass HR**, Novel B219/OB receptor isoforms: possible role of leptin in hemopoiesis and reproduction, *Nat Med* 2:585, 1996.
163. **Zachow RJ, Magoffin DA**, Direct intraovarian effects of leptin: impairment of the synergistic action of insulin-like growth factor-I on follicle-stimulating hormone-dependent estradiol-17 $\beta$  production by rat ovarian granulosa cells, *Endocrinology* 138:847, 1997.

164. **Cioffi JA, Van Blerkom J, Antczak M, Shafer A, Wittmer S, Snodgrass HR**, The expression of leptin and its receptors in pre-ovulatory human follicles, *Mol Hum Reprod* 3:467, 1997.
165. **Frisch RE, Revelle R**, Menstrual cycles: fatness as a determinant of minimum weight-for-height for their maintenance or onset, *Science* 185:949, 1974.
166. **Frisch RE**, Body fat, menarche, and reproductive ability, *Semin Reprod Endocrinol* 3:45, 1985.
167. **Welt CK, Chan JL, Bullen J, Murphy R, Smith P, DePaoli AM, Karalis A, Mantzoros CS**, Recombinant human leptin in women with hypothalamic amenorrhea, *N Engl J Med* 351:987, 2004.
168. **Germain N, Galusca B, Le Roux CW, Bossu C, Ghatel MA, Lang F, Bloom SR, Estour B**, Constitutional thinness and lean anorexia nervosa display opposite concentrations of peptide YY, glucagon-like peptide 1, ghrelin, and leptin, *Am J Clin Nutr* 85:967, 2007.
169. **Dorn LD, Chrousos GP**, The neurobiology of stress: understanding regulation of affect during female biological transitions, *Semin Reprod Endocrinol* 15:19, 1997.
170. **Vulliémoz NR, Xiao E, Xia-Zhang L, Rivier J, Ferin M**, Astressin B, a nonselective corticotropin-releasing hormone receptor antagonist, prevents the inhibitory effect of ghrelin on luteinizing hormone pulse frequency in the ovariectomized rhesus monkey, *Endocrinology* 149:869, 2008.
171. **Vulliémoz NR, Xiao E, Xia-Zhang L, Wardlaw SL, Ferin M**, Central infusion of agouti-related peptide suppresses pulsatile luteinizing hormone release in the ovariectomized rhesus monkey, *Endocrinology* 146:784, 2005.
172. **Miller KK, Parulekar MS, Schoenfeld E, Anderson E, Hubbard J, Klibanski A, Grinspoon SK**, Decreased leptin levels in normal weight women with hypothalamic amenorrhea: the effects of body composition and nutritional intake, *J Clin Endocrinol Metab* 83:2309, 1998.
173. **Wade GN, Schneider JE, Li H-Y**, Control of fertility by metabolic cues, *Am J Physiol* 270(Endocrinol Metab 33):E1, 1996.
174. **Charney E, Goodman HC, McBride M, Lyon B, Pratt R**, Childhood antecedents of adult obesity, *N Engl J Med* 295:6, 1976.
175. **Garn SM, LaVelle M, Rosenberg KR, Hawthorne VM**, Maturation timing as a factor in female fatness and obesity, *Am J Clin Nutr* 43:879, 1986.
176. **Stunkard AJ, Sorensen TIA, Teasdale TW, Chakraborty R, Schull WJ, Schulsinger F**, An adoptive study of human obesity, *N Engl J Med* 314:193, 1986.
177. **Ravussin E, Lillioja S, Knowler WC, Christin L, Freymond D, Abbott WGH, Boyce V, Howard BV, Bogardus C**, Reduced rate of energy expenditure as a risk factor for body-weight gain, *N Engl J Med* 318:467, 1988.
178. **Stunkard AJ, Harris JR, Pederson NL, McClearn GE**, The body-mass index of twins who have been reared apart, *N Engl J Med* 322:1483, 1990.
179. **Whitaker RC, Wright JA, Pepe MS, Seidel KD, Dietz WH**, Predicting obesity in young adulthood from childhood and parental obesity, *N Engl J Med* 337:869, 1997.
180. **Rissanen AM, Heliovaara M, Knekt P, Reunanen A, Aromaa A**, Determinants of weight gain and overweight in adult Finns, *Eur J Clin Nutr* 45:419, 1991.
181. **Ogden CL, Fakhouri TH, Carroll MD, Hales CM, Fryar CD, Li X, Freedman DS**, Prevalence of obesity among adults, by household income and education—United States, 2011–2014, *MMWR Morb Mortal Wkly Rep* 66:1369, 2017.
182. **Ogden CL, Carroll MD, Fakhouri TH, Hales CM, Fryar CD, Li X, Freedman DS**, Prevalence of obesity among youths, by household income and education—United States, 2011–2014, *MMWR Morb Mortal Wkly Rep* 67:186, 2018.
183. **Alberti KG, Eckel RH, Grundy SM, Zimmet PZ, Cleeman JL, Donato KA, Fruchaart JC, James WP, Loria CM, Smith SC Jr; International Diabetes Federation Task Force on Epidemiology and Prevention, National Heart, Lung, and Blood Institute, American Heart Association, World Heart Federation, International Atherosclerosis Society, International Association for the Study of Obesity**, Harmonizing the metabolic syndrome: a joint interim statement of the International Diabetes Federation Task Force on Epidemiology and Prevention; National Heart, Lung, and Blood Institute; American

Heart Association; World Heart Federation; International Atherosclerosis Society; and International Association for the Study of Obesity, *Circulation* 120:1640, 2009.

184. **Hewing R, Liebermeister H, Daweke H, Gries FA, Gruneklee D**, Weight regain after low calorie diet: long term pattern of blood sugar, serum lipids, ketone bodies, and serum insulin levels, *Diabetologia* 9:197, 1973.
185. **Stern MP, Haffner SM**, Body fat distribution and hyperinsulinemia as risk factors for diabetes and cardiovascular disease, *Arteriosclerosis* 6:123, 1986.
186. **Peiris AN, Sothmann MS, Aiman EJ, Kissebah AH**, The relationship of insulin to sex hormone binding globulin: role of adiposity, *Fertil Steril* 52:69, 1989.
187. **Kirschner MA, Samojlik E, Drejda M, Szmal E, Schneider G, Ertel N**, Androgen-estrogen metabolism in women with upper body versus lower body obesity, *J Clin Endocrinol Metab* 70:473, 1990.
188. **Pasquali R, Cantobelli S, Casimirri F, Capelli M, Bortoluzzi L, Flamia R, Labate AMM, Barbara L**, The hypothalamic-pituitary-adrenal axis in obese women with different patterns of body fat distribution, *J Clin Endocrinol Metab* 77:341, 1993.
189. **Wabitsch M, Hauner H, Heinze E, Bockmann A, Benz R, Mayer H, Teller W**, Body fat distribution and steroid hormone concentrations in obese adolescent girls before and after weight reduction, *J Clin Endocrinol Metab* 80:3469, 1995.
190. **Lapidus L, Bengtsson C, Larsson B, Pennert K, Rybo E, Sjostrom L**, Distribution of adipose tissue and risk of cardiovascular disease and death: a 12 year follow up of participants in the population study of women in Gothenburg, *Br Med J* 289:1257, 1984.
191. **Ostlund Jr RE, Staten M, Kohrt W, Schultz J, Malley M**, The ratio of waist-to-hip circumference, plasma insulin level, and glucose intolerance as independent predictors for the HDL2 cholesterol level in older adults, *N Engl J Med* 322:229, 1990.
192. **Deutsch MI, Mueller WH, Malina RM**, Androgyny in fat patterning is associated with obesity in adolescents and young adults, *Ann Hum Biol* 12:275, 1985.
193. **Ashwell M, Chinn S, Stalley S, Garrow JS**, Female fat distribution—a simple classification based on two circumference measurements, *Int J Obes Relat Metab Disord* 6:143, 1982.
194. **Ashwell M, Cole TJ, Dixon AK**, Obesity: new insight into the anthropometric classification of fat distribution shown by computed tomography, *Br Med J* 290:1692, 1985.
195. **Pouliot MC, Despres JP, Lemieux S, Moorjani S, Bouchard C, Tremblay A, Nadeau A, Lupren PJ**, Waist circumference and abdominal sagittal diameter: best simple anthropometric indexes of abdominal visceral adipose tissue accumulation and related cardiovascular risk in men and women, *Am J Cardiol* 73:460, 1994.
196. **Lean MEJ, Han TS, Durenberg P**, Predicting body composition by densitometry from simple anthropometric measurements, *Am J Clin Nutr* 63:4, 1996.
197. **Janssen I, Katzmarzyk PT, Ross R**, Waist circumference and not body mass index explains obesity-related health risk, *Am J Clin Nutr* 79:379, 2004.
198. **de Koning L, Merchant AT, Pogue J, Anand SS**, Waist circumference and waist-to-hip ratio as predictors of cardiovascular events: meta-regression analysis of prospective studies, *Eur Heart J* 28:850, 2007.
199. **Manson JE, Colditz GA, Stampfer MJ, Willett WC, Rosner B, Monson RR, Speizer FE, Hennekens CH**, A prospective study of obesity and risk of coronary heart disease in women, *N Engl J Med* 322:882, 1990.
200. **Williamson DF, Pamuk E, Thun M, Flanders D, Byers T, Heath C**, Prospective study of intentional weight-loss and mortality in never-smoking overweight US white women aged 40–64, *Am J Epidemiol* 141:1128, 1995.
201. **Garrow JS**, Treatment of obesity, *Lancet* 340:409, 1992.
202. **Foster GD, Wyatt HR, Hill JO, McGuckin BG, Brill C, Mohammed BS, Szapary PO, Rader DJ, Edman JS, Klein S**, A randomized trial of a low-carbohydrate diet for obesity, *N Engl J Med* 348:2082, 2003.
203. **Yancy Jr WS, Olsen MK, Guyton JR, Bakst RP, Westman EC**, A low-carbohydrate, ketogenic diet versus a low-fat diet to treat obesity and hyperlipidemia: a randomized, controlled trial, *Ann Intern Med* 140:769, 2004.
204. **Gordon ES**, Metabolic aspects of obesity, *Adv Metab Disord* 4:229, 1970.
205. **National Institutes of Health (NIH) and National Heart Lung and Blood Institute (NHLBI)**, Clinical Guidelines on the Identification, Evaluation, and Treatment of Overweight and Obesity The Evidence Report,

U.S. Government Printing Office, Washington, 1998.

206. **Wadden TA, Stunkard AJ, Brownell KD**, Very low calorie diets: their efficacy, safety, and future, *Ann Intern Med* 99:675, 1983.
207. **Lichtman SW, Pisarska K, Berman ER, Pestone M, Dowling H, Offenbacher E, Weisel H, Heshka S, Matthews DE, Heymsfield SB**, Discrepancy between self-reported and actual caloric intake and exercise in obese subjects, *N Engl J Med* 327:1893, 1992.
208. **Volkmar FR, Stunkard AJ, Woolston J, Bailey RA**, High attrition rates in commercial weight reduction programs, *Arch Intern Med* 141:426, 1981.
209. **Grodstein F, Levine R, Troy L, Spencer T, Colditz GA, Stampfer MJ**, Three-year follow-up of participants in a commercial weight loss program. Can you keep it off?, *Arch Intern Med* 156:1302, 1996.
210. **Heshka S, Anderson JW, Atkinson RL, Greenway FL, Hill JO, Phinney SD, Kolotkin RL, Miller-Kovach K, Pi-Sunyer FX**, Weight loss with self-help compared with a structured commercial program. A randomized trial, *JAMA* 289:1792, 2003.
211. **Dansinger ML, Gleason JA, Griffith JL, Selker HP, Schaefer EJ**, Comparison of the Atkins, Ornish, Weight Watchers, and Zone diets for weight loss and heart disease risk reduction: a randomized trial, *JAMA* 293:43, 2005.
212. **Wadden TA, Berkowitz RI, Womble LG, Sarwer DB, Phelan S, Cato RK, Hesson LA, Osel SY, Kaplan RC, Stunkard AJ**, Randomized trial of lifestyle modification and pharmacotherapy for obesity, *N Engl J Med* 353:2111, 2005.
213. **Truby H, Baic S, deLooy A, Fox KR, Livingstone MB, Logan CM, Macdonald IA, Morgan LM, Taylor MA, Millward DJ**, Randomised controlled trial of four commercial weight loss programmes in the UK: initial findings from the BBC "diet trials," *Br Med J* 332:1309, 2006.
214. **Gardner CD, Kiazand A, Alhassan S, Kim SH, Stafford RS, Balise RR, Kraemer HC, King AC**, Comparison of the Atkins, Zone, Ornish, and LEARN diets for change in weight and related risk factors among overweight premenopausal women: the A to Z Weight Loss Study: a randomized trial, *JAMA* 297:969, 2007.
215. **Sjöström CD, Lissner L, Sjöström L**, Relationships between changes in body composition and changes in cardiovascular risk factors: the SOS Intervention Study, *Obes Res* 5:519, 1997.
216. **Diabetes Prevention Program Research Council**, Reduction in the incidence of type 2 diabetes with lifestyle intervention or metformin, *N Engl J Med* 346: 393, 2002.
217. **Diabetes Prevention Program Research Group**, 10-Year follow-up of diabetes incidence and weight loss in the Diabetes Prevention Program Outcomes Study, *Lancet* 374:1677, 2009.
218. **Flegal KM, Troiano RP, Pamuk ER, Kuczmarski RJ, Campbell SM**, The influence of smoking cessation on the prevalence of overweight in the United States, *N Engl J Med* 333:1165, 1995.
219. **Sjöström L, Rissanen A, Andersen T, Boldrin M, Golay A, Koppeschaar HPF, Krempf M; for the European Multicentre Orlistat Study Group**, Randomised placebo-controlled trial of orlistat for weight loss and prevention of weight regain in obese patients, *Lancet* 352:167, 1998.
220. **Larsen PJ, Fledelius C, Knudsen LB, Tang-Christensen M**, Systemic administration of the long-acting GLP-1 derivative NN2211 induces lasting and reversible weight loss in both normal and obese rats, *Diabetes* 50:2530, 2001.
221. **Astrup A, Rössner S, Van Gaal L, Rissanen A, Niskanen L, Al Hakim M, Madsen J, Rasmussen MF, Lean ME; NN8022-1807 Study Group**, Effects of liraglutide in the treatment of obesity: a randomised, double-blind, placebo-controlled study, *Lancet* 374:1606, 2009.
222. **Thomsen WJ, Grottick AJ, Menzaghi F, Reyes-Saldana H, Espitia S, Yuskin D, Whelan K, Martin M, Morgan M, Chen W, Al-Shamma H, Smith B, Chalmers D, Behan D**, Lorcaserin, a novel selective human 5-hydroxytryptamine<sub>2C</sub> agonist: in vitro and in vivo pharmacological characterization, *J Pharmacol Exp Ther* 325:577, 2008.
223. **Abenham L, Moride Y, Brenot F, Rich S, Benichou J, Kurz X, Higenbottom T, Oakley C, Wouters E, Aubier M, Simonneau G, Begaud B**, Appetite-suppressant drugs and the risk of primary pulmonary hypertension, *N Engl J Med* 335:609, 1996.



224. **Connolly HM, Crary JL, McGoon MD, Hensrud DD, Edwards BS, Edwards WD, Schaff HV**, Valvular heart disease associated with fenfluramine-phentermine, *N Engl J Med* 337:581, 1997.
225. **Graham DJ, Green L**, Further cases of valvular heart disease associated with fenfluramine-phentermine, *N Engl J Med* 337:635, 1997.
226. **Goldstein DJ, Rampey Jr AH, Enas GG, Potvin JH, Fludzinski LA, Levine LR**, Fluoxetine: a randomized clinical trial in the treatment of obesity, *Int J Obes Relat Metab Disord* 18:129, 1994.
227. **Michelson D, Amsterdam JD, Quitkin FM, Reimherr FW, Rosenbaum JF, Zajecka J, Sundell KL, Kim Y, Beasley CM Jr**, Changes in weight during a 1-year trial of fluoxetine, *Am J Psychiatry* 156:1170, 1999.
228. **Bray GA, Blackburn GL, Ferguson JM, Greenway FL, Jain AK, Mendel CM, Mendels J, Ryan DH, Schwartz SL, Scheinbaum ML, Seaton TB**, Sibutramine produces dose-related weight loss, *Obes Res* 7:189, 1999.
229. **Van Gaal LF, Rissanen AM, Scheen AJ, Ziegler O, Rössner S; RIO-Europe Study Group**, Effects of the cannabinoid-1 receptor blocker rimonabant on weight reduction and cardiovascular risk factors in overweight patients: 1-year experience from the RIO-Europe study, *Lancet* 365:1389, 2005.
230. **Pi-Sunyer FX, Aronne LJ, Heshmati HM, Devin J, Rosenstock J; RIO-North America Study Group**, Effect of rimonabant, a cannabinoid-1 receptor blocker, on weight and cardiometabolic risk factors in overweight or obese patients: RIO-North America: a randomized controlled trial, *JAMA* 295:761, 2006.
231. **Sam AH, Salem V, Ghatei MA**, Rimonabant: from RIO to Ban, *J Obes* 2011:432607, 2011.
232. **Khera R, Murad MH, Chandar AK, Dulai PS, Wang Z, Prokop LJ, Loomba R, Camilleri M, Singh S**, Association of pharmacological treatments for obesity with weight loss and adverse events: a systematic review and meta-analysis, *JAMA* 315:2424, 2016.
233. **Li Z, Maglione M, Tu W, Mojica W, Arterburn D, Hugarman LR, Hilton L, Suttorp M, Solomon V, Shekelle PG, Morton SC**, Meta-analysis: pharmacologic treatment of obesity, *Ann Intern Med* 142:532, 2005.
234. **Sjöström L, Narbro K, Sjöström CD, Karason K, Larsson B, Wedel H, Lystig T, Sullivan M, Bouchard C, Carlsson B, Bengtsson C, Dahlgren S, Gummesson A, Jacobson P, Karlsson J, Lindross AK, Lönroth H, Näslund I, Olbers T, Stenlöf K, Torgerson J, Agren G, Carlsson LM; Swedish Obese Subjects Study**, Effects of bariatric surgery on mortality in Swedish obese subjects, *N Engl J Med* 357:741, 2007.
235. **Cunneen SA**, Review of meta-analytic comparisons of bariatric surgery with a focus on laparoscopic adjustable gastric banding, *Surg Obes Relat Dis* 4: S47, 2008.
236. **Treadwell JR, Sun F, Schoelles K**, Systematic review and meta-analysis of bariatric surgery for pediatric obesity, *Ann Surg* 248:763, 2008.
237. **Buchwald H, Estok R, Fahrbach K, Banel D, Jensen MD, Pories WJ, Bantje JP, Sledge I**, Weight and type 2 diabetes after bariatric surgery: systematic review and meta-analysis, *Am J Med* 122:248, 2009.
238. **Longitudinal Assessment of Bariatric Surgery (LABS) Consortium; Flum DR, Belle SH, King WC, Wahed AS, Berk P, Chapman W, Pories W, Courcoulas A, McCloskey C, Mitchell J, Patterson E, Pomp A, Staten MA, Yanovski SZ, Thirlby R, Wolfe B**, Perioperative safety in the longitudinal assessment of bariatric surgery, *N Engl J Med* 361:445, 2009.
239. **Rivlin RS**, Drug therapy: therapy of obesity with hormones, *N Engl J Med* 292:26, 1975.
240. **Paffenbarger RS Jr, Wing AL, Hyde RT**, Physical activity as an index of heart attack risk in college alumni, *Am J Epidemiol* 108:161, 1978.
241. **Weisweiler P**, Plasma lipoproteins and lipase and lecithin: cholesterol acyltransferase activities in obese subjects before and after weight reduction, *J Clin Endocrinol Metab* 65:969, 1987.
242. **Jakicic JM, Marcus BH, Gallagher KI, Napolitano M, Lang W**, Effect of exercise duration and intensity on weight loss in overweight, sedentary women, *JAMA* 290:1323, 2003.
243. **Safer DJ**, Diet, behavior modification, and exercise: a review of obesity treatments from a long-term perspective, *South Med J* 84:1470, 1991.
244. **Skender ML**, Comparison of a 2-year weight loss trends in behavioral treatments of obesity: diet, exercise,

and combination interventions, *J Am Diet Assoc* 96:342, 1996.

245. **Jensen MK, Chiuve SE, Rimm EB, Dethlefsen C, Tjønneland A, Joensen AM, Overvad K**, Obesity, behavioral lifestyle factors, and risk of acute coronary events, *Circulation* 117:3062, 2008.
246. **Konishi F**, Food energy equivalents of various activities, *J Am Diet Assoc* 46: 186, 1965.
247. **Sims EAH, Danforth E Jr, Horton ES, Bray GA, Glennon JA, Salans LB**, Endocrine and metabolic effects of experimental obesity in man, *Recent Prog Horm Res* 29:457, 1973.
248. **Welle SL, Amatruda JM, Forbes GB, Lockwood DH**, Resting metabolic rates of obese women after rapid weight loss, *J Clin Endocrinol Metab* 59:41, 1984.
249. **Leibel RL, Rosenbaum M, Hirsch J**, Changes in energy expenditure resulting from altered body weight, *N Engl J Med* 332:621, 1995.

---

# Reproduction and the Thyroid

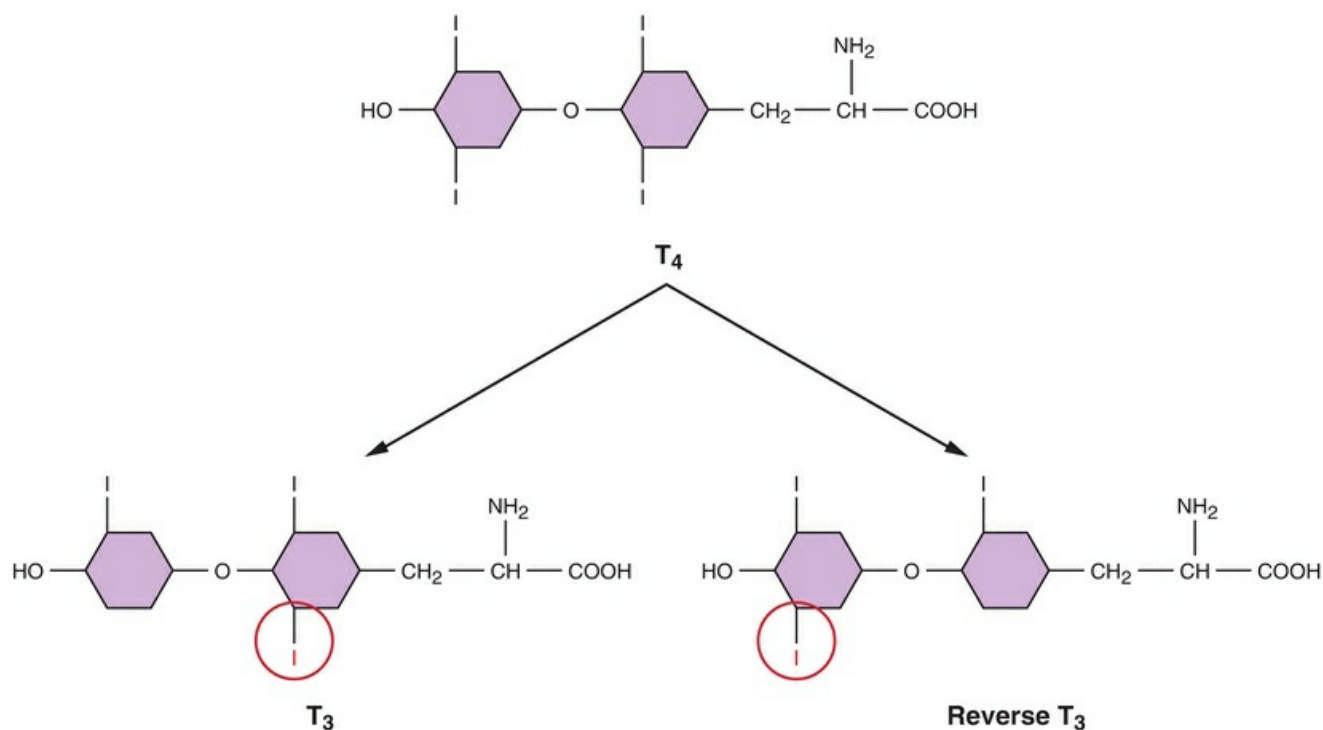
Thomas Wharton, in 1656, gave the thyroid gland its modern name (meaning oblong shield) because he believed that the function of the thyroid was to fill vacant spaces and contribute to the shape and beauty of the neck, especially in women.<sup>1</sup>

For unknown reasons, thyroid disease is more common in women than in men. Because most thyroid disease is autoimmune in nature, an increased susceptibility to autoimmune diseases, perhaps secondary to the female endocrine environment, is a likely contributing factor.

The clinical objective is to detect and treat thyroid disease before the symptoms and signs are significant and intense. Subtle thyroid disease is easily diagnosed by the sensitive laboratory assessments now available. Therefore, the key to early diagnosis is to maintain a high index of suspicion and to readily screen for the presence of abnormal thyroid function. There is growing support to institute routine thyroid screening in three female populations: older women, pregnant women, and women with infertility.

# NORMAL THYROID PHYSIOLOGY

Thyroid hormone synthesis depends in large part on an adequate supply of iodine in the diet. In the small intestine, iodine (I) is absorbed as iodide ( $I^-$ ) that is then transported to the thyroid gland. Plasma iodide enters the thyroid under the influence of thyroid-stimulating hormone (TSH), the anterior pituitary thyrotropin hormone. Within the thyroid gland, iodide is oxidized to elemental iodine, which is then bound to tyrosine. Monoiodotyrosine and diiodotyrosine combine to form thyroxine ( $T_4$ ) and triiodothyronine ( $T_3$ ). These iodinated compounds are part of the thyroglobulin molecule, the large (660 kDa) protein that is stored in the thyroid follicle and serves as a depot for thyroid hormones. TSH induces a proteolytic process that results in the release of iodothyronines into the bloodstream as thyroid hormone (**Figure 20.1**).



**FIGURE 20.1**

Removal of one iodine from the phenolic ring of  $T_4$  yields  $T_3$ , whereas removal of an iodine from the nonphenolic ring yields reverse  $T_3$  (RT3), which is biologically inactive. In a normal adult, about one-third of the  $T_4$  secreted each day is converted in peripheral tissues to  $T_3$ , and about 40% is converted to the inactive, RT3. About 80% of the  $T_3$  generated is derived outside the thyroid gland, chiefly in the liver and kidney.  $T_3$  is 3–5 times more potent than  $T_4$ , because the nuclear thyroid receptor has a 10-fold greater affinity for  $T_3$  than for  $T_4$ . Consequently, although  $T_4$  is secreted at 20 times the

rate of T3, it is T3 that is responsible for most if not all of the thyroid action in the body, while T4 serves mainly as a prohormone of T3. It is hard to think of a body process or function that does not require thyroid hormone for its normal operation, not only metabolism but also development, steroidogenesis, and most specific tissue activities.

Carbohydrate calories appear to be the primary determinant of T3 levels in adults. A reciprocal relationship exists between T3 and RT3. Low T3 and elevated RT3 are seen in a variety of illnesses such as febrile diseases, burn injuries, malnutrition, and anorexia nervosa. The metabolic rate is determined to a large degree by the relative production of T3 and RT3. During periods of stress, when a decrease in metabolic rate would conserve energy, the body produces more RT3 and less T3, and metabolism slows. On recovery, this process reverses, and metabolic rate increases.

Thyroid hormones are present in the circulation mainly bound to proteins. Approximately 70% of thyroid hormones are bound to thyroxine-binding globulin (TBG), which, therefore, is the major determining factor in the total thyroid hormone concentration in the circulation. The remaining 30% is bound to thyroxine-binding prealbumin and albumin. The binding proteins have a greater affinity for T4 and, thus, allow T3 to have greater entry into cells. TBG is synthesized in the liver, and this synthesis is increased by estrogens. The passage of thyroid hormones into and out of cells is regulated by cell membrane thyroid hormone transporters; mutations in a key transporter are associated with elevated T3 levels and psychomotor retardation.<sup>2</sup>

The nuclear receptor for thyroid hormone is a member of the super family that includes the steroid hormone receptors ([Chapter 1](#)).<sup>3</sup> The thyroid hormone receptor exists in several forms, the products of two genes located on different chromosomes. The  $\alpha$  receptor gene is on chromosome 17, and the  $\beta$  receptor gene is on chromosome 3. The nuclear T3 receptor is truly ubiquitous, indicating the widespread actions of thyroid hormone throughout the body. Mutations in the gene for the thyroid receptor may lead to the synthesis of a receptor that actually antagonizes normal receptors, a syndrome of thyroid resistance characterized by elevated thyroid hormone levels. TSH is elevated as well because of the impairment in thyroid hormone action.

The thyroid axis is stimulated by the hypothalamic factor, thyrotropin-releasing hormone (TRH), and inhibited by somatostatin and dopamine. Thyroid hormones regulate TSH by suppressing TRH secretion, but primarily by affecting the pituitary sensitivity to TRH (by reducing the number of TRH receptors). Pituitary secretion of TSH is very sensitive to changes in the circulating levels of thyroid hormone; a slight change in the circulating level of T4 will produce a many-fold greater response in TSH. TSH-secreting cells are regulated by T4 but only after the T4 is converted to T3 in the pituitary cells. Although modulation of thyroid hormone occurs at the pituitary level, this function is permitted by the hypothalamic releasing hormone, TRH. Indeed, while some

tissues depend mainly on the blood T3 for their intracellular T3, the brain and the pituitary depend on their own intracellular conversion of T4. The measurement of T4 and TSH, therefore, provides the most accurate assessment of thyroid function.

The TSH response to TRH is influenced mainly by the thyroid hormone concentration in the circulation; however, lesser effects are associated with dopamine agonists (inhibition), glucocorticoids (inhibition), and dopamine antagonists (stimulation). Estrogen increases the TRH receptor content of the pituitary; hence, the TSH response to TRH is greater in women than in men and greater in women taking estrogen-progestin contraceptives.

TRH also stimulates prolactin secretion by the pituitary. The smallest doses of TRH that are capable of producing an increase in TSH also increase prolactin levels, indicating a physiologic role for TRH in the control of prolactin secretion. However, except in hypothyroidism, normal physiologic changes as well as abnormal prolactin secretion can be understood in terms of dopaminergic inhibitory control, and TRH need not be considered.

# Functional Changes with Aging

Thyroxine metabolism and clearance decrease in older people, and thyroxine secretion decreases in compensation to maintain normal serum thyroxine concentrations.<sup>4</sup> With aging, conversion of T4 to T3 decreases, and TSH levels increase. The TSH response to TRH is normal in older women. TBG concentrations decrease slightly in postmenopausal women but not enough to alter measurements in serum.

# THYROID FUNCTION TESTS

---



## **Free Thyroxine (FT4)**

Assays that measure free T4 are usually displacement assays using an antibody to T4. The result is not affected by changes in TBG and binding. The free T4 level has a different range of normal values from laboratory to laboratory but is usually 0.8–2.0 ng/dL.

## **Total Thyroxine (TT4)**

The total thyroxine, both the bound portion to TBG and the free unbound portion, is measured by displacement assays, and, in the absence of hormone therapy or other illnesses, it estimates the thyroxine concentration in the blood. However, the free T4 is unaffected by factors that influence TBG and is preferred.

## **Free Thyroxine Index (FTI or T7)**

The free thyroxine index is calculated from the TT4 and the T3 resin uptake measurements. This test has been replaced by the free T4 assay.

## **Total T3 and Reverse T3**

Both of these thyronines can be measured by sensitive immunoassays. However, in most clinical circumstances, they add little to what is learned by the free T4 and TSH measurements. The clinical situations in which measurement will be useful are discussed under the specific diseases and indicated on the algorithm.

# Thyroid-Stimulating Hormone

TSH (also called thyrotropin) is measured by highly sensitive assays using monoclonal antibodies, usually in a technique that uses two antibodies, one directed at the  $\alpha$  subunit and one directed at the  $\beta$  subunit of TSH. The normal levels vary from laboratory to laboratory, but the sensitive TSH assay can detect concentrations as low as 0.01  $\mu\text{U/mL}$ , and the normal range is usually 0.45–4.5  $\mu\text{U/mL}$ . White people and the elderly normally have slightly higher TSH levels (individuals 80 years and older may have an upper limit as high as 7.5  $\mu\text{U/mL}$ ), making the upper limit for the normal range more difficult to interpret.<sup>5,6</sup> TSH is a very sensitive indicator of thyroid hormone action at the tissue level because it is dependent on the pituitary exposure to T<sub>4</sub>. In the absence of hypothalamic or pituitary disease, the sensitive TSH assay will provide the best indication of excess or deficient thyroxine; slight changes in T<sub>4</sub> are reflected in a many-fold greater response in TSH. Nearly all women with elevated TSH levels have hypothyroidism. Transient changes in TSH can be caused by systemic illnesses, major psychiatric disturbances, and pharmacologic treatment with glucocorticoid agents or dopamine.

# TSH Receptor, Thyroid Peroxidase, and Thyroglobulin Autoantibodies

Autoimmune thyroid disease is characterized by the presence of autoantibodies against various thyroid components, namely the TSH receptor, thyroid peroxidase (TPO), and thyroglobulin (Tg), as well as an inflammatory cellular infiltrate of variable severity within the gland.

Autoantibodies that compete with TSH for its receptor are collectively known as TSH receptor autoantibodies (TRAb) and include thyroid-stimulating immunoglobulin (TSI) and thyrotropin-binding inhibitory immunoglobulin (TBII). All forms of autoimmune thyrotoxicosis (Graves disease, Hashitoxicosis, neonatal thyrotoxicosis) are caused by the production of stimulating TRAb.

TRAb test is a binding assay that detects both TSI and TBII; it can be used instead of TSI assay for most applications, as long as the results are interpreted in the clinical context. Most patients with Graves disease will have detectable TRAbs. This is an essential test in patients with hyperthyroidism to differentiate Graves disease from nonautoimmune hyperthyroidism, specifically toxic multinodular goiter, in order to select appropriate therapy. This test (or TSI test) is not needed to monitor treatment.

The role of the TPO and Tg autoantibodies in either autoimmune thyrotoxicosis or autoimmune hypothyroidism is less well established; they may merely represent epiphenomena. Detectable concentrations of anti-TPO antibodies are observed in most patients with autoimmune thyroid disease (e.g., Hashimoto thyroiditis, idiopathic myxedema, and Graves disease).

# Radioactive Iodine Uptake Scan

Because the thyroid gland is the only tissue that utilizes iodine, radioisotopes of iodine can be used as a measure of thyroid gland activity and to localize activity within the gland. The scan is obtained 24 hours after the administration of  $I^{123}$  given orally.

# The Laboratory Evaluation

The algorithm represents a cost-effective and accurate clinical strategy. For screening purposes, or when there is a relatively low clinical suspicion of thyroid disease, the initial step is to measure TSH. A normal TSH essentially excludes hypothyroidism or hyperthyroidism. A high TSH requires the measurement of free T4 to confirm the diagnosis of hypothyroidism.

If the initial TSH is low, especially less than  $0.08 \mu\text{U/mL}$ , then measurement of a high T4 will confirm the diagnosis of hyperthyroidism. If the T4 is normal, the T3 level is measured, because some patients with hyperthyroidism will have predominantly T3 toxicosis. If the T3 is normal, this compensated state is called subclinical hyperthyroidism. Some of these patients will eventually have increased T4 or T3 levels with true hyperthyroidism.

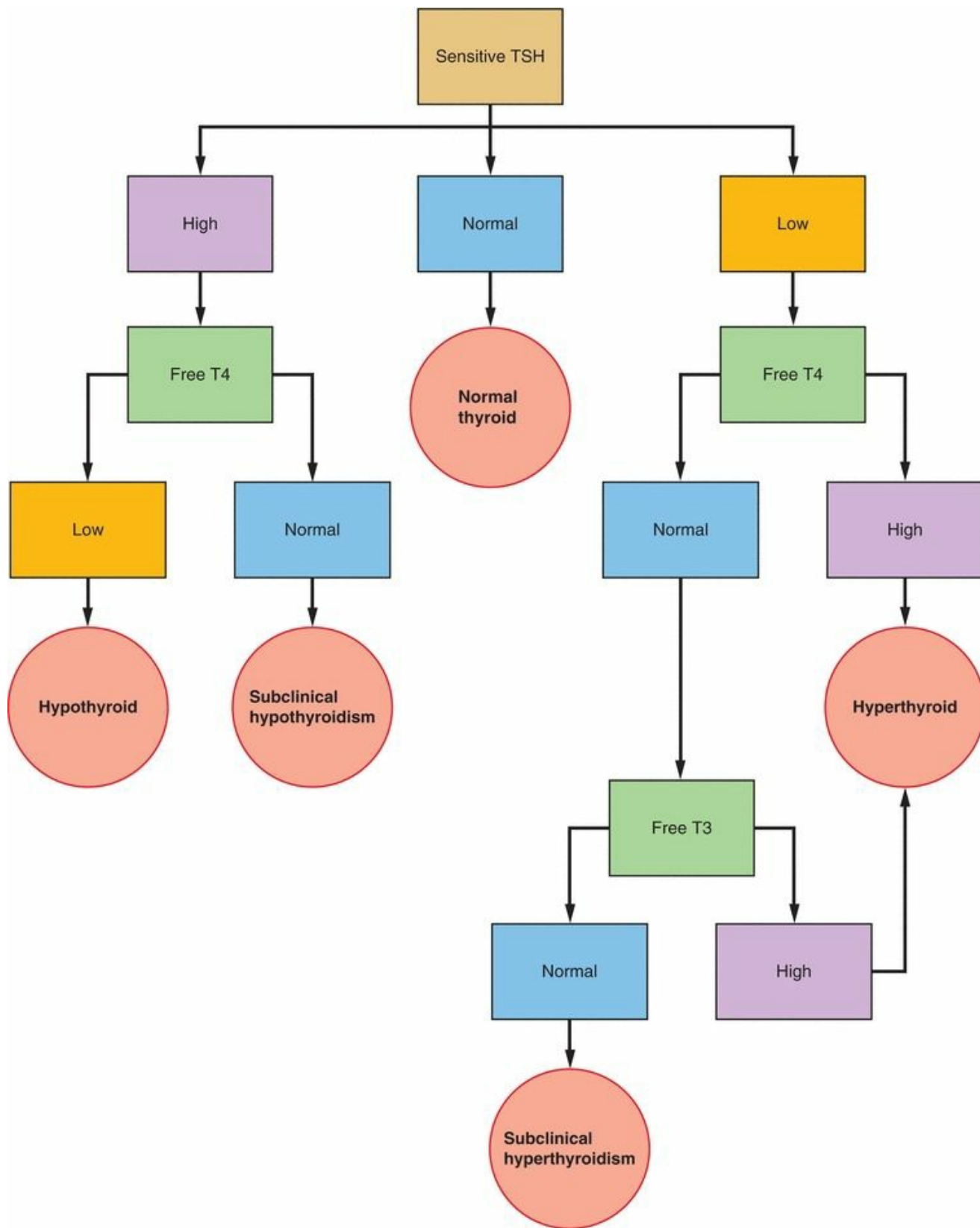


# HYPOTHYROIDISM

---

In most cases of hypothyroidism, a specific cause is not apparent. It is believed that hypothyroidism is usually secondary to an autoimmune reaction, and, when goiter formation is present, it is called Hashimoto thyroiditis.<sup>7</sup> Unless abnormal thyroid function can be documented by specific laboratory assessment, empiric treatment with thyroid hormone is not indicated. Hypothyroidism is also associated with recurrent miscarriages, and an assessment of thyroid function is worthwhile in these patients.

Hypothyroidism increases with aging and is more common in women.<sup>8</sup> Up to 45% of thyroid glands from women older than age 60 show evidence of thyroiditis.<sup>9</sup> In women admitted to geriatric wards, 2–4% have clinically apparent hypothyroidism. **Therefore, hypothyroidism is frequent enough to warrant consideration in most older women, justifying screening even in asymptomatic older women. We recommend that women be screened with the TSH assay every 5 years beginning at age 35, then every 2 years beginning at age 60, or with the appearance of any symptoms suggesting hypothyroidism (Figure 20.2).**<sup>10,11</sup>



**FIGURE 20.2**

Menstrual irregularities and bleeding problems are common in hypothyroid women.

Amenorrhea can be a consequence of hypothyroidism, either with TRH-induced increases in prolactin or with normal prolactin levels. Other clinical manifestations of hypothyroidism include constipation, cold intolerance, psychomotor retardation, carpal tunnel syndrome, and decreased exercise tolerance. However, patients often are asymptomatic. Close evaluation can reveal mental slowness, decreased energy, fatigue, poor memory, somnolence, slow speech, a low-pitched voice, water retention, periorbital edema, delayed reflexes, or a low body temperature and bradycardia. Hypothyroidism can also cause hypertension, cognitive abnormalities, pericardial effusion, asymmetric septal myocardial hypertrophy, myopathy, neuropathy, ataxia, anemia, elevated cholesterol and LDL-cholesterol, or hyponatremia. Myxedematous infiltration can produce enlarged, cystic ovaries.<sup>12</sup> The increase in cholesterol is due to impaired LDL-cholesterol clearance secondary to a decrease in cell membrane LDL receptors. The mechanism for this LDL effect is attributed to a thyroid response element in the LDL receptor gene.<sup>13</sup>

Serum enzymes may be elevated because of decreased clearance, including creatine phosphokinase (CPK), aspartate aminotransferase (AST, SGOT), alanine aminotransferase (ALT, SGPT), lactic dehydrogenase (LDH), and alkaline phosphatase, triggering a fruitless search for other organ disease. **It is worth screening for hypothyroidism in any women with abnormal menses or with complaints of fatigue and depression. In addition, patients who have elevated levels of cholesterol and LDL-cholesterol should be screened.**

# Diagnosis of Hypothyroidism

With primary thyroid failure, the circulating thyroid hormone levels fall, stimulating the pituitary to increase TSH output. Elevated TSH and low T4 confirm the diagnosis. The prevalence of hypothyroidism is estimated to be 4.5% of among those 12 years or older.<sup>14</sup> The most common cause is autoimmune thyroid disease (elevated titers of antithyroid antibodies) in areas with normal iodine intake. Hypothyroidism can also occur due to pituitary failure in which case the TSH will be inappropriately low for the T4. However, making an etiologic diagnosis in women adds little to the clinical management.

## Subclinical Hypothyroidism

In early hypothyroidism, with undetectable symptoms or signs, a compensated state can be detected by an elevated TSH (greater than the upper limit of the normal range of 0.45–4.5  $\mu\text{U}/\text{mL}$ ) and normal T4 (called subclinical hypothyroidism). Subclinical hypothyroidism is present in 4–8.5% of U.S. adults, is more common in women, and increases with age, affecting up to 20% of women over age 60.<sup>15,16</sup> Of those with subclinical hypothyroidism, about 2–5% **each year** will become clinically hypothyroid with low T4 concentrations.<sup>15,16</sup>

A good reason to treat subclinical hypothyroidism is to avoid the development of a goiter. Furthermore, some patients in retrospect (after treatment) recognize improved physical and mental well-being. Patients with subclinical hypothyroidism have alterations in energy metabolism in skeletal muscle.<sup>17</sup> An improvement in impaired cognitive function and emotional behavior has been documented with thyroxine treatment of subclinical hypothyroidism.<sup>18</sup> In those patients who are asymptomatic, it is worth measuring antithyroid antibodies. A positive test identifies those who are more likely to become clinically hypothyroid, at a rate of approximately 20% per year. With only very slight elevations of TSH ( $<10 \mu\text{U}/\text{mL}$ ), it is reasonable not to treat asymptomatic patients, especially those over age 80, and to check thyroid function every 6 months to detect further deterioration; however, symptomatic patients may benefit from treatment.<sup>15</sup> Patients with an abnormal cholesterol-lipoprotein profile can show a rapid improvement with thyroxine treatment.<sup>19,20,21</sup> Subclinical hypothyroidism is a strong risk factor for coronary heart disease.<sup>22</sup> In addition, iron deficiency anemia is common in patients with subclinical hypothyroidism and responds better when levothyroxine is added to iron treatment.<sup>23</sup>

The risk of pregnancy loss is increased for women with uncorrected overt or even subclinical hypothyroidism. The results of a study of pregnancy outcomes in women

with hypothyroidism challenged the notion that subclinical hypothyroidism has no impact on pregnancy.<sup>24</sup> The incidence of pregnancy loss was very low in treated hypothyroid women having normal thyroid indices but markedly increased in women with elevated TSH levels, including both women with untreated subclinical disease and those with overt disease who received inadequate exogenous thyroid hormone replacement. **These observations indicate that subclinical hypothyroidism may not be entirely benign and further justify recommendations to include TSH screening in the evaluation of women with recurrent pregnancy loss.**

# Treatment of Hypothyroidism

Initial therapy is straightforward with synthetic thyroxine, T4, given daily. Mixtures of T4 and T3, such as desiccated thyroid, provide T3 in excess of normal thyroid secretion. It is better to provide T4 and allow the peripheral conversion process to provide the T3.<sup>25,26</sup> “Natural” thyroid preparations are not better and in fact are potentially detrimental. Patients taking biologic preparations should be switched to synthetic thyroxine. Studies have documented that adding T3 to T4 does not improve treatment outcomes.<sup>27,28,29</sup> Because of a risk of coronary heart disease in older women, the initial dose should be 25–50 µg/day for 4 weeks, at which time the dose is increased by 25 µg daily every 4 weeks according to the clinical and biochemical assessment. Usually the dose required will be close to 1.5 µg/lb body weight, but it may be less in very old women.<sup>30</sup> The average final dose required in the elderly is approximately 70% of that in younger patients. **Patients who have been on thyroid hormone for a long time may have their medication discontinued. Recovery of the hypothalamic-pituitary axis usually requires 8 weeks at which time the TSH and free T4 levels can be measured.**

## Evaluation of Therapy

When the patient appears clinically euthyroid, evaluation of TSH levels will provide the most accurate assessment of the adequacy of thyroid hormone replacement. The goal is to maintain the TSH in the **lower half** of the normal range, between 0.45 and 2.0 µU/mL.<sup>7,31</sup> Thyroid hormone requirements decrease with age. A patient being treated with thyroid hormone should be evaluated once every year with the TSH assay, and each patient should consistently remain on the same levothyroxine product. If the TSH level is low, then the free T4 should be measured to help adjust the thyroxine dose.<sup>32</sup> **The full response of TSH to changes in T4 is relatively slow; a minimum of 8 weeks is necessary between changes in dosage and assessment of TSH.**

# HYPERTHYROIDISM

---

Hyperthyroidism affects 1.3% of adult US population,<sup>14</sup> and its two primary causes are Graves disease (toxic diffuse goiter) and Plummer disease (toxic nodular goiter).<sup>33</sup> Plummer disease is usually encountered in postmenopausal women who have had a long history of goiter. Twenty percent of hyperthyroid patients are older than 60, and 25% of older women with hyperthyroidism present with an apathetic or atypical syndrome.

Graves disease, about 5–10 times more common in women than in men, is characterized by the triad of hyperthyroidism, ophthalmopathy, and pretibial myxedema and is caused by autoantibodies that have TSH properties and, therefore, bind to and activate the TSH receptor. The measurement of TSH receptor antibodies is essential to distinguish Graves disease from toxic nodular goiter. Menstrual changes associated with hyperthyroidism are unpredictable, ranging from amenorrhea to oligomenorrhea to normal cycles (hence, the amenorrhea in a thyrotoxic woman can be due to pregnancy).

The classic symptoms of thyrotoxicosis are nervousness, disturbed sleep, heat intolerance, weight loss, sweating, palpitations, and diarrhea. These symptoms are associated with typical findings on physical examination: proptosis, lid lag, tachycardia, tremor, warm and moist skin, and goiter. Women in the reproductive years usually present with the classic picture. In postmenopausal women, symptoms are often concentrated in a single organ system, especially the cardiovascular or central nervous system. Goiter is absent in 40%. Sinus tachycardia occurs in less than half, but atrial fibrillation occurs in 40% and is resistant to cardioversion or spontaneous reversion to sinus rhythm. In old women, there is often a coexistent disease, such as an infection or coronary heart disease that dominates the clinical picture.

Hyperthyroidism in older women is sometimes described as “apathetic hyperthyroidism” because the clinical manifestations are different. The triad of weight loss, constipation, and loss of appetite, suggesting gastrointestinal malignancy, occurs in about 15% of older patients with hyperthyroidism. Ophthalmopathy is rare in older patients. The clinician should consider the diagnosis in older patients with “failure to thrive”; in patients who are progressively deteriorating for unexplained reasons; and in patients with heart disease, and unexplained weight loss. Mental or psychological changes are not unusual in hyperthyroid women. Women who complain of emotional lability and nervousness should be screened for hyperthyroidism.

# Diagnosis of Hyperthyroidism

The diagnosis of hyperthyroidism requires laboratory testing. A suppressed TSH (below 0.4  $\mu\text{U}/\text{mL}$ ) with a high T4 or a high T3 confirms the diagnosis. Graves disease is associated with the presence of TRAb. The measurement of TRAb in all patients with hyperthyroidism is important in order to confirm a diagnosis of Graves disease.<sup>34</sup> Most patients should have a radioactive iodine uptake scan after laboratory confirmation of the diagnosis. The scan will indicate whether the patient has a diffuse toxic goiter, a solitary hot (functional) nodule, or a hot nodule in a multinodular gland. Toxic multinodular goiters occur more frequently in the elderly. TSH hypersecretion as a cause of hyperthyroidism is extremely rare; the combination of a normal or elevated TSH and elevated thyroid hormone will be the clue to this possibility.



# Subclinical Hyperthyroidism

By definition, patients with subclinical hyperthyroidism have normal T4 and T3 levels but subnormal concentrations of TSH. About 2% of U.S. adults will have subclinical hyperthyroidism, more common in women and blacks.<sup>16</sup>

TSH levels can be suppressed to 0.1–0.5  $\mu\text{U}/\text{mL}$  by general illnesses and drugs such as glucocorticoids, dopamine, and anticonvulsants; however, this suppression does not extend below 0.1  $\mu\text{U}/\text{mL}$ . Values below 0.1  $\mu\text{U}/\text{mL}$  are regarded as nondetectable, and patients with overt hyperthyroidism usually have undetectable TSH. Subclinical hyperthyroidism is half as common in older people as subclinical hypothyroidism (excluding the most common cause, treatment with excessive doses of thyroxine). Keep in mind that the dose of thyroxine required to treat hypothyroidism declines with age (because of the decrease in metabolic clearance with age); all patients being treated with thyroid hormone should have their TSH levels assessed every year. Atrial fibrillation is a common cardiovascular problem associated with subclinical hyperthyroidism, especially in older women when the TSH is less than 0.1  $\mu\text{U}/\text{mL}$ .<sup>16,35</sup> Progression to overt hyperthyroidism is uncommon and essentially limited to patients with a TSH level lower than 0.1  $\mu\text{U}/\text{mL}$ . **Therefore, TSH levels less than 0.1  $\mu\text{U}/\text{mL}$  should be treated to avoid bone loss and atrial fibrillation in older women, or in those at risk for osteoporosis and heart disease. With TSH levels of 0.1–0.4  $\mu\text{U}/\text{mL}$ , treatment is indicated only in older patients while TSH follow-up in younger women is warranted every 6 months.**<sup>16,36,37</sup>

# Treatment of Hyperthyroidism

There are multiple objectives of therapy: control of thyroid hormone effects on peripheral tissues by pharmacologic blockade of beta-adrenergic receptors, inhibition of thyroid gland secretion and release of thyroid hormone, and specific treatment of nonthyroidal systemic illnesses that can exacerbate hyperthyroidism or be adversely affected by hyperthyroidism.<sup>38</sup> Antithyroid drugs are administered first to achieve euthyroidism before definitive therapy is accomplished by radioactive iodine treatment only when symptoms are severe or when radioactive iodine therapy must be delayed. Of course, it is important to ensure that a woman is not pregnant before treatment with radioactive iodine, and pregnancy should be postponed for several months after treatment. Monitoring treatment response requires a full 8-week interval for stabilization of the hypothalamic-pituitary-thyroid system.

## Antithyroid Drugs

The drug of choice in most circumstances (except in pregnant women, as discussed later) is methimazole because it has fewer adverse effects. The drug inhibits organification of iodide and decreases production of T<sub>4</sub> and T<sub>3</sub>. The oral dose is 10–20 mg daily. The onset of effect takes 2–4 weeks. Remember that the half-life of thyroxine is about 1 week, and the gland usually has large stores of T<sub>4</sub>. Maximal effect occurs at 4–8 weeks. Once the disease is controlled, the dose can be titrated down to a maintenance dose of 5–10 mg daily. The major side effects are rash, gastrointestinal symptoms, and agranulocytosis (an idiosyncratic reaction). Propranolol and other beta-blockers are effective in rapidly controlling the effects of thyroid hormone on peripheral tissues. The dose is usually 20–40 mg, every 12 hours orally, and the dose is titrated to maintain a heart rate of about 100 beats/minute. The drug may cause bronchospasm, worsening congestive heart failure, fatigue, and depression. Rarely inorganic iodine is needed to block release of hormone from the gland. Lugol solution, 2 drops in water daily, is sufficient. The onset of effect is 1–2 days, with maximal effect in 3–7 days. There may be an escape from protection in 2–6 weeks, and the drug can cause rash, fever, and parotitis. Iodine precludes radioiodine administration for several months.

Most patients to be treated with radioactive iodine are not pretreated with antithyroid drugs. Some patients with hot nodules in multinodular glands require surgery because of the size of the gland and because the hyperthyroidism tends to recur in new nodules after the ablation of the original hot nodule. This can result in repetitive treatments with substantial doses of radioactive iodine, and surgery may be preferable. All patients definitively treated for hyperthyroidism must be monitored for the onset of hypothyroidism.

# OSTEOPOROSIS AND EXCESSIVE THYROXINE

---

Because postmenopausal women are at increased risk for osteoporosis and frequently develop hyperthyroidism or receive levothyroxine treatment for hypothyroidism, it is important to understand how thyroid hormone affects bones. Thyroid hormone excess alters bone integrity via direct effects on bone and gut absorption of calcium and indirectly through the effects of vitamin D, calcitonin, and parathyroid hormone.<sup>39</sup>

Thyroid hormone increases bone mineral resorption. In addition, total and ionized calcium increase in hyperthyroid women, leading to increases in serum phosphorus, alkaline phosphatase, and bone Gla protein (osteocalcin), a marker of bone turnover. Parathyroid hormone decreases in response to the increased serum calcium, and this results in decreased hydroxylation of vitamin D. Intestinal calcium and phosphate absorption decrease, while urinary hydroxyproline and calcium excretion increase. The net effect of excessive thyroid hormone is increased bone resorption and a subsequent decrease in bone density—osteoporosis.<sup>40</sup>

These effects become more clinically important in prolonged exposure to excessive thyroid hormone.<sup>41</sup> Women who have had hyperthyroidism are at greater risk for fractures and experience postmenopausal fractures earlier than usual.<sup>42,43</sup> Postmenopausal women with subclinical hyperthyroidism have lower bone density measurements and experience a higher rate of fractures.<sup>44,45</sup>

A major concern is that mild chronic excess thyroid hormone replacement, especially in postmenopausal women, might increase the risk of osteoporosis, and indeed this has been documented.<sup>46,47</sup> A meta-analysis of the literature on this subject concluded that premenopausal women treated for long durations did not suffer a clinically significant loss of bone (probably because of the protective presence of estrogen); nevertheless, postmenopausal women lose an excess of bone if thyroid treatment results in TSH levels below the normal range.<sup>48</sup> Case-control and cohort studies, however, have been unable to detect an increase in fractures associated with thyroid hormone administration.<sup>49,50,51</sup>

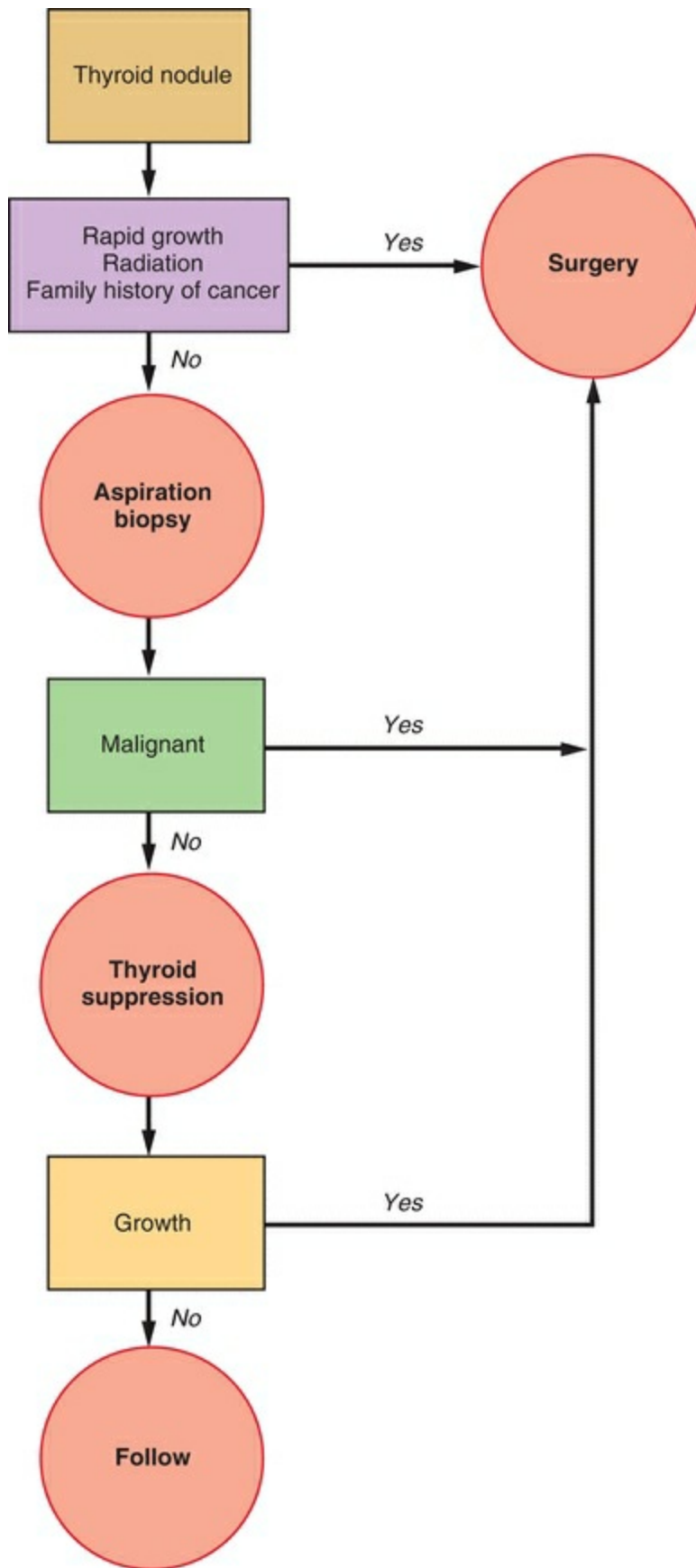
Because this is a problem easily avoided, we believe that exposure to excessive thyroxine must be added to the risk factors for osteoporosis. It makes sense to monitor patients (both premenopausal women and especially postmenopausal women) receiving thyroxine with TSH levels to ensure that levothyroxine doses are “physiologic.” Some patients who require TSH suppressive doses of thyroxine, such as patients with cancer, must be considered at increased risk of osteoporosis. It would be wise to assess bone density in women on long-term thyroid treatment and in women receiving high-dose

thyroxine suppression of TSH. The use of estrogen replacement therapy, exercise programs, and possibly bisphosphonate treatment must be seriously considered for these patients. In a cross-sectional study of elderly women, the bone loss associated with long-term thyroid treatment was avoided in those women also taking estrogen.<sup>52</sup>

# THYROID NODULES

---

The major concern with thyroid nodules is the potential for thyroid cancer.<sup>53</sup> Single nodules are 4 times more common in women, and carcinoma of the thyroid is nearly 3 times more common in women than in men. The incidence rises steadily after the age of 55. Mortality from thyroid cancer occurs predominantly in the middle aged and the elderly. There are four major types of primary thyroid carcinoma: papillary, follicular, anaplastic, and medullary. In solitary nodules that are “cold” (those that do not take up radioactive iodine or pertechnetate on thyroid scan), 12% prove to be malignant. This also means that the majority are benign (**Figure 20.3**). Surgical excision of nodules can result in vocal cord paralysis, hypoparathyroidism, and other complications. Therefore, the goal is to select patients for curative surgery who have the greatest likelihood of having cancer in the nodule.



**FIGURE 20.3**

# Epidemiologic and Clinical Data

The major risk factors for thyroid cancer are family history of this disease or a history of irradiation to head or neck. In those who have received thyroid irradiation, about one-third will have thyroid abnormalities, and about one-third of those with abnormalities will have thyroid cancer (about 10% overall). The carcinogenic risk has been estimated to be 1% per 100 rad in 20 years.

A rapidly growing nodule, a hard nodule, the presence of palpable regional lymph nodes, or vocal cord paralysis greatly increase the probability of thyroid cancer. The risk of thyroid cancer in patients with multiple nodules is not less than in those with single nodules.<sup>54</sup> Therefore, they should be similarly assessed.

Thyroid nodules in multinodular thyroid glands, not previously exposed to thyroid irradiation, have no greater risk of thyroid carcinoma than normal glands. Therefore, predominant thyroid nodules in multinodular glands should be followed, and, if a nodule grows, then biopsy or surgery should be considered.

# Diagnostic Strategy

Detection of a thyroid nodule is followed by clinical characterization of the nodule; examination of the lymph nodes; and inquiry regarding rapid growth, history of thyroid irradiation, and family history. In the presence of any positive findings, surgery is recommended for excision of the nodule. Laboratory assessment of thyroid function is also essential in patients with a thyroid nodule, as abnormal thyroid function is almost always associated with benign etiology. In patients with a thyroid nodule and no personal or family history suggestive of increased risk of thyroid cancer, a fine needle aspiration biopsy is indicated if serum TSH level is normal. In those with low TSH indicating an active nodule, a thyroid scan would be helpful, while high TSH would necessitate testing antithyroid antibodies to diagnose autoimmune inflammation. Ultrasonography of the thyroid is also necessary to identify the presence of nonpalpable nodules and to guide fine needle biopsy. Suppression with levothyroxine treatment is no longer recommended for two reasons: poor efficacy and an inability to differentiate benign lesions from thyroid cancer.

Although accounting for only 5% of thyroid cancers, medullary carcinoma is associated with early spread and poor survival rates. Medullary carcinoma of the thyroid is unique in having serum calcitonin as a very sensitive and specific tumor marker. Measuring serum calcitonin is recommended for older patients with solitary nodules to achieve earlier diagnosis of medullary carcinoma.<sup>55</sup>

Thyroid nodules discovered during pregnancy are not managed differently. Pregnancy does not affect the course of thyroid malignancy, and low-grade tumors can be treated after delivery.<sup>56</sup> Radioactive iodine, of course, must not be administered during pregnancy.



# Fine Needle Aspiration

Fine needle aspiration biopsy has an 83% sensitivity and 92% specificity in diagnosing thyroid malignancy.<sup>57</sup> When “indeterminate” by biopsy, about one-third prove to be malignant at thyroidectomy. If the fine needle aspiration biopsy reveals suspicious cells or is indeterminate, a subtotal thyroidectomy should be performed for diagnosis and treatment. If the aspiration biopsy is benign, some would repeat the biopsy in 1 year to avoid false negatives. Growth indicates the need for biopsy or surgery. In some cases, especially in older women, nodules can be followed with little risk.

# THE THYROID GLAND AND PREGNANCY

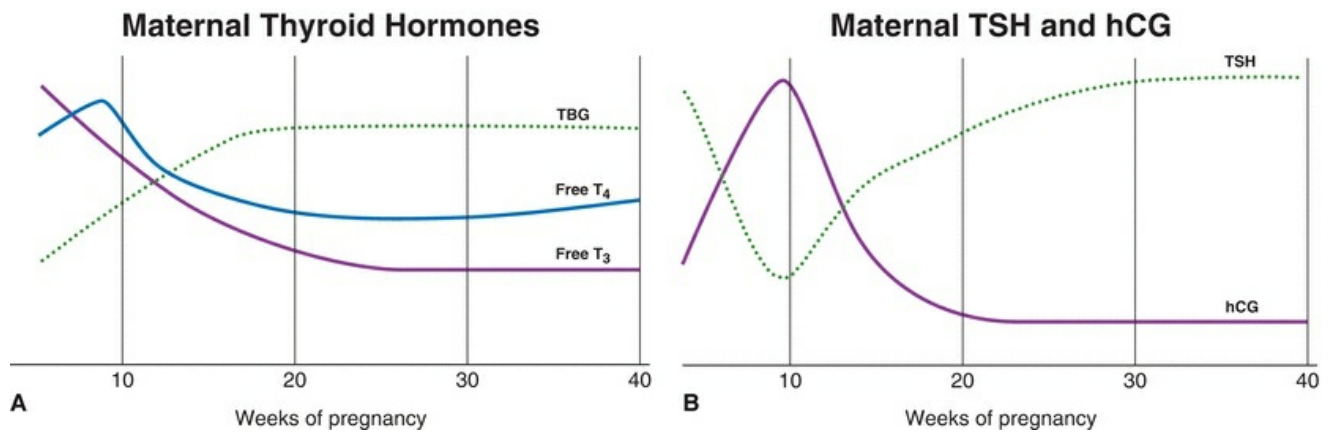
---

In response to the metabolic demands of pregnancy, there is an increase in the basal metabolic rate (which is mainly due to fetal metabolism), iodine uptake, and the size of the thyroid gland (caused by hyperplasia and increased vascularity).<sup>58</sup> However, despite this increase in thyroid activity, a pregnant woman is euthyroid with levels of TSH, free T4, and free T3 remaining within the normal range; thyroid nodules and goiter require evaluation. During pregnancy, iodide clearance by the kidney increases. For this reason (plus the iodide losses to the fetus), the prevalence of goiter is increased in areas of iodine deficiency.<sup>59</sup> This is not a problem in the United States, while in many parts of the world where iodine is not sufficiently available in the environment, pregnancy increases the risk of iodine deficiency. The increase in thyroid activity in pregnancy is attributed to the thyrotropic substances secreted by the placenta: the thyrotropic activity in human chorionic gonadotropin (hCG) and a chorionic thyrotropin.<sup>60,61</sup> The thyroid-stimulating activity of hCG is explained by the molecular homology between hCG and TSH, and between their receptors, and it has been calculated that hCG contains approximately 1/4,000th of the thyrotropic activity of human TSH. Especially during early pregnancy, hCG causes a small but important increase in maternal thyroid hormones for the fetus until fetal thyroid function is sufficient to serve fetal needs.<sup>61,62,63</sup> In conditions with very elevated hCG levels (trophoblastic disease, hCG-secreting cancers), the thyrotropic activity can be sufficient to produce hyperthyroidism (gestational hyperthyroidism), and this can even be encountered in normal pregnancy.<sup>64</sup>

The increase in thyroid activity in pregnancy is accompanied by a marked increase in the circulating levels of TBG in response to estrogen; therefore, a new equilibrium is reached with an increase in the bound portion of the thyroid hormone. The mechanism for the estrogen effect on TBG is an increase in hepatic synthesis and an increase in glycosylation of the TBG molecule that leads to decreased clearance.

TBG levels reach a peak (twice nonpregnant levels) at about 15 weeks, which is maintained throughout the rest of pregnancy.<sup>62</sup> T4 undergoes a small increase in the first trimester, but T3 increases more markedly. Because of the increase in TBG, free T4 and T3 levels then decrease, although they remain within the normal range.<sup>65</sup> There is an inverse relationship between maternal circulation levels of TSH and hCG.<sup>62</sup> TSH reaches a nadir at the same time that hCG reaches a peak at 10 weeks of pregnancy. TSH levels then increase as hCG levels drop to their stable levels throughout the rest of pregnancy. **Thus, the range of normal for TSH levels change with each trimester.**<sup>66</sup> **The lower limit of TSH in the first, second, and third trimesters are 0.1, 0.2, and 0.3  $\mu$ U/L, respectively. The upper limit of normal in the first trimester is 2.5 and 3.0  $\mu$ U/L in the second and third trimesters.**<sup>67,68</sup> In normal pregnancies, placental transfer

of TSH, T4, and T3 is limited in both directions. Slight, but significant, transfer of T4 and T3 does occur, however, when maternal levels are very high or when fetal levels are substantially lower than the maternal levels. Therefore, in the early weeks of pregnancy, before the fetal thyroid gland becomes active, the fetal brain is dependent on the placental transport of maternal T4.<sup>69</sup> Both overt and subclinical maternal hypothyroidism are associated with increased risks of miscarriage, preeclampsia, low birth weight, premature delivery, and a decrease in intelligence in the children<sup>24,70,71,72,73,74</sup> (Figure 20.4).



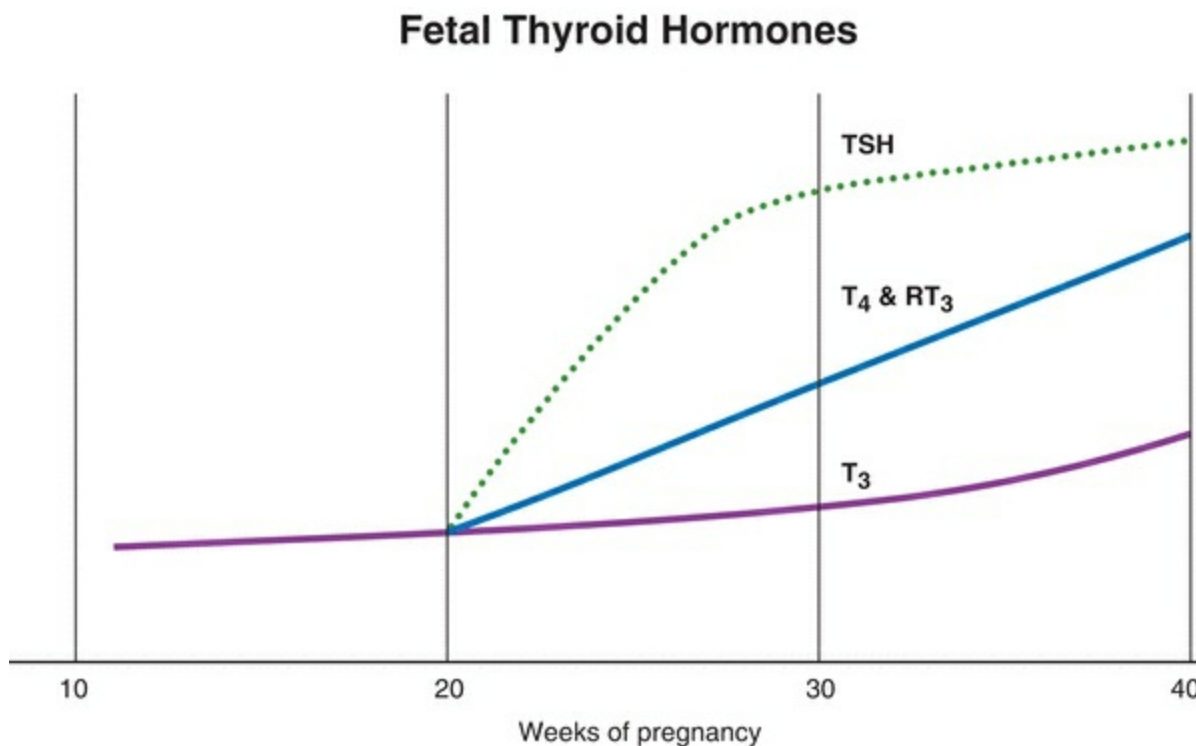
**FIGURE 20.4**

The majority of patients with hyperemesis gravidarum have laboratory values consistent with hyperthyroidism, and the severity of the hyperemesis correlates with the degree of hyperthyroidism.<sup>75,76</sup> These patients have higher levels of hCG, and the transient hyperthyroidism and severity of the hyperemesis may be mediated by the thyrotropic and steroidogenic activity of the hCG. These clinical manifestations in normal pregnancies may be linked to a specific subpopulation of hCG molecules with greater thyrotropic bioactivity (because highly purified, standard hCG has only trivial TSH-like activity).<sup>77</sup> Specifically, hCG with reduced sialic acid content is increased in pregnant patients with hyperemesis and hyperthyroidism.<sup>78</sup> Women with hyperemesis gravidarum do not require antithyroid drug treatment unless they exhibit symptoms of hyperthyroidism, supported by appropriate laboratory results.

# Thyroid Physiology in the Fetus and the Neonate

The human fetal thyroid gland develops the capacity to concentrate iodine and synthesize hormone between 8 and 10 weeks of gestation, at the same time that the pituitary begins to synthesize TSH.<sup>79,80</sup> Some thyroid development and hormone synthesis are possible in the absence of the pituitary gland, but optimal function requires TSH. By 12–14 weeks, development of the pituitary-thyroid system is complete. Function is minimal, however, until an abrupt increase in fetal TSH occurs at 20 weeks. As with gonadotropin and other pituitary hormone secretion, this increase in thyroid function correlates with the maturation of the hypothalamus and the development of the pituitary portal vascular system, which makes releasing hormone available to the pituitary gland.

Fetal TSH increases and reaches a plateau at 28 weeks and remains at relatively high levels to term. The free T4 concentration increases progressively. At term, fetal T4 levels exceed maternal levels. Thus, a state of fetal thyroidal hyperactivity exists near term<sup>81</sup> (Figure 20.5).



**FIGURE 20.5**

The major thyroid hormone secreted by the fetus is T4, while total T3 and free T3 levels are low throughout gestation, and levels of RT3 are elevated, paralleling the rise

in T4. Like T3, this compound is derived predominantly from conversion of T4 in peripheral tissues. The increased production of T4 in fetal life is compensated by rapid conversion to the inactive RT3, allowing the fetus to conserve its fuel resources. However, there is some evidence that RT3, as well as T4, through nongenomic actions, regulate fetal brain development.<sup>82</sup> With delivery, the newborn moves from a state of relative T3 deficiency to a state of T3 thyrotoxicosis. Shortly after birth, serum TSH concentrations increase rapidly to a peak at 30 minutes of age. They fall to baseline values by 48–72 hours. In response to this increase in TSH, total T4 and free T4 increase to peak values by 24–48 hours of age. T3 levels increase even more, peaking by 24 hours of age. By 3–4 weeks, the thyroidal hyperactivity has disappeared.

The postnatal surge in TSH is accompanied by a prolactin surge, suggesting that both are increased in response to TRH. The TRH surge is thought to be a response to rapid neonatal cooling. A puzzle is the fact that the early increase in T3 is independent of TSH and is tied in some way to cutting of the umbilical cord. Delaying cord cutting delays the increase in T3, but TSH levels still reach their peak at 30 minutes. Probably by changing liver perfusion, cord cutting augments peripheral (largely liver) conversion of T4 to T3. The later increases in T3 and T4 (after 2 hours) are due to increased thyroid gland activity. These changes in thyroid function after birth probably represent an adaptation mechanism for the sudden entry into the cold world. The high RT3 levels during pregnancy continue during the first 3–5 days of life and then fall gradually to normal levels by 2 weeks.

## Key Points: Fetal and Newborn Thyroid Changes

- TSH and T4 appear in the fetus at 10–13 weeks. Levels are low until an abrupt rise at 20 weeks.
- T4 rises rapidly and exceeds maternal values at term.
- T3 levels rise, but concentrations are relatively low, similar to hypothyroid adults.
- RT3 levels exceed normal adult levels.
- The fetal pattern of low T3 and high RT3 is similar to that seen with calorie malnutrition.
- After delivery, TSH peaks at 30 minutes of age, followed by a T3 peak at 24 hours and a T4 peak at 24–48 hours. The T3 increase is independent of the TSH change.
- High RT3 levels persist for 3–5 days after delivery and then reach normal values by 2 weeks.

# HYPOTHYROIDISM IN PREGNANCY

---

Serious hypothyroidism is rarely encountered during pregnancy. Patients with this degree of illness usually do not get pregnant. Many patients with mild hypothyroidism never have a laboratory assessment for thyroid function during pregnancy and go undetected. Preeclampsia, intrauterine growth retardation, fetal distress, and fetal death are more frequent in women with significant hypothyroidism or with subclinical hypothyroidism.<sup>24,70,71,72,73,74,83,84</sup> There is also reason to believe that patients with hypothyroidism, even subclinical hypothyroidism, have an increased rate of spontaneous miscarriage.<sup>24,83,84,85</sup> The mechanism may be impaired function of important organs such as the endometrium, the corpus luteum, and especially the placenta. The children born to women with hypothyroidism have deficits in intelligence; remember that in the first half of pregnancy, the fetus is dependent on maternal thyroid hormones.<sup>86,87,88,89,90</sup> For all of these reasons, a strong case can be made for detecting and treating hypothyroidism prior to or early in pregnancy. **Preconceptual screening is ideal with establishment of the euthyroid state (a TSH not higher than 2.5  $\mu$ U/L) before pregnancy.**<sup>67,68</sup> **The upper limit of normal in the first trimester is 2.5 and 3.0  $\mu$ U/L in the second and third trimesters.**<sup>67,68</sup> There is no debate in regard to treating pregnant women who are hypothyroid; however, detecting and treating women with elevated TSH and normal T4 levels (subclinical hypothyroidism) is controversial, as is what should be considered elevated TSH.<sup>67,68,91,92</sup>

Universal screening of pregnant women will detect both subclinical hypothyroidism and subclinical hyperthyroidism, each present in a substantial number of asymptomatic women.<sup>73,93,94</sup> Advocacy for universal screening is not an established recommendation. A major prospective U.S. study could not detect adverse outcomes associated with maternal thyroid hypofunction, although only 247 women had low thyroid function out of a population of 10,990 patients.<sup>94</sup> The conservative approach, as expressed by the American College of Obstetricians and Gynecologists, is to await the results of clinical trials.<sup>91</sup> Because there is a consensus to treat subclinical hypothyroid function in nonpregnant women, in our view, it is only logical to apply the same standard to pregnant women. This includes measuring antithyroid antibodies in women with elevated TSH levels because a positive test identifies those who are likely to become clinically hypothyroid. Women with thyroid antibodies have a significant risk of becoming hypothyroid as pregnancy progresses and also an increased risk of postpartum thyroiditis.<sup>95</sup>

Women with positive thyroid antibodies undergoing in vitro fertilization may experience a lower pregnancy rate and an increase in spontaneous miscarriage, which

can potentially be prevented with levothyroxine treatment.<sup>74,96</sup> The experience with assisted reproduction emphasizes the importance of detecting and treating less than normal thyroid function. Pregnant women treated for hypothyroidism have been reported to have an increase in preeclampsia, diabetes, and preterm birth.<sup>97,98</sup> **The obstetrical complications in treated women may reflect a lack of appreciation for the change in thyroid hormone requirement during pregnancy.**

Women being treated for hypothyroidism require an increase (20–50%) in thyroxine during pregnancy, beginning as early as the 5th week of pregnancy.<sup>99,100,101</sup> The reasons for this increase include the estrogen-induced increase in TBG, the dilutional effect of the increase in vascular volume, and the increase in placental transport and metabolism. When previously diagnosed hypothyroid women become pregnant, it is best to empirically increase the levothyroxine dose by about 30% as soon as pregnancy is diagnosed, with further adjustments according to the TSH levels.<sup>101,102</sup> **TSH should be monitored monthly and again in the postpartum period, and dosage should be adjusted to keep the TSH level in the lower half of the normal range, less than 2.5  $\mu\text{U}/\text{mL}$  in the first trimester and less than 3.0  $\mu\text{U}/\text{mL}$  in the rest of pregnancy.** Postpartum, the dose should be immediately decreased to the prepregnancy level. The need for proper monitoring and adequate treatment cannot be overemphasized; surveys of pregnant women with hypothyroidism find a substantial number with either excessive suppression of TSH or elevated TSH levels.<sup>83,103</sup> Women with thyroid autoimmunity (presence of thyroid antibodies) must be monitored with TSH levels for at least 6 months after delivery because of their increased risk for postpartum thyroiditis.

# Newborn Screening for Hypothyroidism

Impaired thyroid function may be limited to the fetus, the mother, or may affect both. Fetal hypothyroidism may be permanent or transient. Transient fetal hypothyroidism is most commonly due to transplacental passage of autoantibodies or drugs, while combined maternal and fetal hypothyroidism is almost always caused by iodine deficiency.

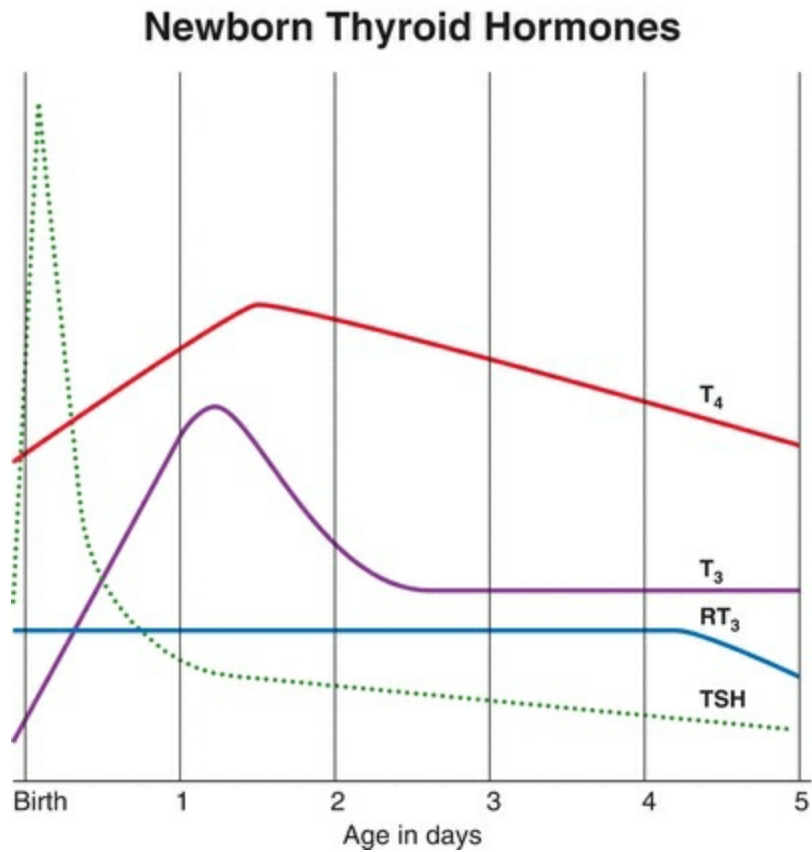
Fetal permanent hypothyroidism is mostly caused by congenital hypothyroidism (incidence is about 1 in 4,000 live births), and newborn screening programs exist in most of the world.<sup>104</sup> Majority of congenital hypothyroidism cases are due to thyroid dysgenesis and are not clinically apparent at birth. Fortunately, infants with congenital hypothyroidism have low T4 and high TSH concentrations easily detected in blood, and early high-dose treatment before 3 months of age is usually associated with normal mental development,<sup>105</sup> while persistent impaired mental performance has been observed in long-term follow-up studies.<sup>106,107</sup> Less than normal development can be a consequence of a delay in treatment or inadequate dosage, but despite early treatment with high doses, extremely low thyroid hormone production in the fetus is associated with deficits later in life.<sup>108</sup> Recently, a failure to develop normally in a small percentage of individuals despite early diagnosis and treatment has been linked to genetic defects in transcription factors (FOXE-1, NKX2.1, PAX8) that are important for both the thyroid gland and the central nervous system.<sup>109,110</sup>

There is a familial tendency for hypothyroidism, and if the diagnosis is made in the antepartum period, intra-amniotic injections of thyroxine can raise fetal levels of thyroid hormone.<sup>111</sup> A early clue to the presence of congenital hypothyroidism is a reduction in baseline variability in fetal heart rate tracings.<sup>112</sup> Ultrasonographic examination of patients with polyhydramnios should include a search for a fetal goiter. In addition, the fetus should be monitored for goiter formation in women treated with antithyroid drugs for hyperthyroidism during pregnancy. Amniotic fluid iodothyronines and TSH reflect fetal plasma levels, and abnormal values may allow prenatal diagnosis of fetal hypothyroidism by amniocentesis.<sup>111,113</sup> However, fetal cord blood sampling is advocated for accurate diagnosis.<sup>114</sup> Treatment of fetal hypothyroidism is important because prenatal hypothyroidism can affect some aspects of development, for example, the full function of physical skills.

The fetus is iodine deficient when a mother's iodine intake is low. Supplying the mother adequate iodine is an important problem in many parts of the world.<sup>115</sup> A fetal goiter is occasionally detected by ultrasonography at a size that could impede normal delivery. The fetus can be treated, with regression of the goiter, by the administration of



levothyroxine into the amniotic fluid.<sup>116</sup> However, the fetus is usually protected by the transplacental transfer of maternal T<sub>4</sub>, and, therefore, fetal treatment of hypothyroidism can usually be postponed until delivery (**Figure 20.6**).



**FIGURE 20.6**

# Postpartum Thyroiditis

Autoimmune thyroid disease is suppressed to some degree by the immunologic changes of pregnancy. Thus, there is a relatively high incidence of postpartum thyroiditis (5–10%), 1–6 months after delivery (most commonly at 3 months), manifested by either hyperthyroidism or hypothyroidism, although usually transient hyperthyroidism (lasting 1–2 months) is followed by hypothyroidism.<sup>117,118</sup> This condition is due to a destructive thyroiditis associated with thyroid microsomal autoantibodies.<sup>119</sup> A possible etiologic mechanism is fetal microchimerism, the presence of fetal cells in the maternal thyroid gland.<sup>120</sup> Women at high risk for postpartum thyroiditis are those with a personal or family history of autoimmune disease, and those with a previous postpartum episode. Women with insulin-requiring diabetes mellitus are at particularly high risk.<sup>121</sup> Postpartum thyroiditis can also be triggered by an early miscarriage.<sup>122</sup> **Women at high risk for postpartum thyroiditis, especially those with thyroid antibodies, should have TSH measurements at 3 and 6 months postpartum.**

Most importantly, the symptoms in these women are often attributed to anxiety or depression, and the obstetrician must have a high index of suspicion for hypothyroidism. The symptoms usually last 1–3 months, and almost all women return to normal thyroid function. Postpartum thyroiditis tends to recur with subsequent pregnancies, and eventually hypothyroidism remains.<sup>123</sup> Because spontaneous remission is common, patients who are treated for hypothyroidism should be reassessed 1 year after gradual withdrawal of thyroxine. **Patients who return to normal should undergo annual laboratory surveillance of their thyroid status; at least 20% and probably more will develop hypothyroidism in the next 5–10 years.**<sup>124</sup>

# Hyperthyroidism in Pregnancy

Untreated thyrotoxicosis in pregnancy is associated with a higher risk of preeclampsia, heart failure, intrauterine growth retardation, preterm birth, and stillbirth.<sup>125,126</sup> Heart failure is a consequence of the demands of pregnancy superimposed on the hyperdynamic cardiovascular state induced by increased thyroid hormones.<sup>127</sup>

The most common cause of thyrotoxicosis in pregnancy is Graves disease. Most patients with Graves disease will have detectable levels of TRAb. The clinician should always keep in mind that trophoblastic disease can cause hyperthyroidism due to the TSH property inherent in hCG. The maternal changes with pregnancy can make diagnosis difficult. Tachycardia on awakening from sleep and a failure to gain weight should make a clinician suspicious. Hyperemesis gravidarum is a common presentation of hyperthyroidism in pregnancy. Laboratory assessment is unaffected by pregnancy and should follow our algorithm. TRAb will be undetectable in gestational hyperthyroidism. **Remember that the range of normal for TSH levels change with each trimester.**<sup>66</sup> **The lower limit of TSH in the first, second, and third trimesters are 0.1, 0.2, and 0.3  $\mu$ U/L, respectively.**<sup>67</sup>

**Subclinical hyperthyroidism need not be treated as it is not associated with adverse obstetrical and neonatal complications.**<sup>128,129</sup> **Women with gestational hyperthyroidism associated with hyperemesis gravidarum seldom have clinical signs of hyperthyroidism and usually experience a rapid, spontaneous recovery within a few weeks. A few women with gestational hyperthyroidism will require antithyroid drug treatment; therefore, screening all women with hyperemesis for thyroid function is strongly recommended.**

Most women can be successfully treated with thioamide drugs propylthiouracil and methimazole, which are equally effective for pregnant women.<sup>125</sup> Although the data are controversial, methimazole has been associated with teratogenesis and therefore is not recommended during the first trimester, making propylthiouracil the drug of choice.<sup>56,93</sup> During the second and third trimester, methimazole is preferred due to hepatotoxicity associated with propylthiouracil.<sup>93</sup>

The aim of treatment should be to use the lowest possible dose to keep T4 at a high normal or slightly above normal level while maintaining mild hyperthyroidism in the mother to avoid thyroid dysfunction in the fetus. Treatment of maternal hyperthyroidism with propylthiouracil, even with moderate doses of 100–200 mg daily, suppresses T4 and increases TSH levels in newborns.<sup>130</sup> The infants are clinically euthyroid, however, and their laboratory measurements are normal by the 4th to 5th day of life. In addition, follow-up assessment has indicated unimpaired intellectual development in children

whose mothers received propylthiouracil during pregnancy.<sup>131</sup> With proper antithyroid drug treatment, very few, if any, deleterious effects are experienced by mother, fetus, or neonate.<sup>132</sup> Although small amounts of antithyroid drugs are transmitted in breast milk, the amount has no impact on neonatal thyroid function, and breast-feeding should be encouraged. Propylthiouracil is the preferred antithyroid drug in breast-feeding patients because it is less concentrated in breast milk.<sup>133</sup> Poor control of maternal hyperthyroidism is associated with increased risks of preeclampsia and low birth weight infants.<sup>126</sup>

Maternal TSH receptor autoantibodies (stimulating TRAb, TSI) can cross the placenta and cause fetal thyrotoxicosis and demise. Some have advocated fetal cord blood sampling in women with Graves disease who are euthyroid but who have positive titers of TRAb to assess the fetal thyroid status.<sup>134</sup> However, the size of the fetal thyroid can be monitored by ultrasonography and be used to monitor treatment of maternal hyperthyroidism.<sup>135,136</sup> Fetal cord blood sampling is rarely needed. An increase in fetal thyroid size on ultrasonography indicates excessive treatment, and, when dosage reductions are ineffective in reducing size, fetal thyrotoxicosis should be suspected because of the transplacental passage of TSH-like antibodies. Close monitoring of the fetus is not necessary if the maternal TRAb measurements are negative.<sup>136</sup> The fetus can be treated by treating the mother. Neonates have to be observed closely until antithyroid drugs are cleared (a few days) and the true thyroid state can be assessed.

# REFERENCES

1. **Medvei VC**, The History of Clinical Endocrinology, The Parthenon Publishing Group, New York, 1993.
2. **Heuer H, Visser TJ**, Minireview: pathophysiological importance of thyroid hormone transporters, *Endocrinology* 150:1078, 2009.
3. **Brent GA**, The molecular basis of thyroid hormone action, *N Engl J Med* 331:847, 1994.
4. **Melmed S, Hershman J**, The thyroid and aging, In: Korenman SG, ed. *Endocrine Aspects of Aging*, Elsevier Science Publishing, New York, 1982, p. 33.
5. **Surks MI, Hollowell JG**, Age-specific distribution of serum thyrotropin and antithyroid antibodies in the US population: implications for the prevalence of subclinical hypothyroidism, *J Clin Endocrinol Metab* 92:4575, 2007.
6. **Boucai L, Surks MI**, Reference limits for serum TSH differ significantly between races and with age, potentially causing erroneous diagnosis in a substantial number of patients, *Clin Endocrinol* 70:788, 2009.
7. **Roberts CGP, Ladenson PW**, Hypothyroidism, *Lancet* 363:793, 2004.
8. **Hollowell JG, Staehling NW, Flanders WD, Hannon WH, Gunter EW, Spencer CA, Braverman LE**, Serum TSH, T4, and thyroid antibodies in the United States population (1988 to 1994): National Health and Nutrition Examination Survey (NHANES III), *J Clin Endocrinol Metab* 87:489, 2002.
9. **Felicetta JV**, Thyroid changes with aging: significance and management, *Geriatrics* 42:86, 1987.
10. **Danese MD, Powe NR, Sawin CT, Ladenson PW**, Screening for mild thyroid failure at the periodic health examination. A decision and cost-effectiveness analysis, *JAMA* 276:285, 1996.
11. **Gharib H, Tuttle RM, Baskin HJ, Fish LH, Singer PA, McDermott MT**, Consensus Statement #1: Subclinical thyroid dysfunction: a joint statement on management from the American Association of Clinical Endocrinologists, the American Thyroid Association, and The Endocrine Society, *Thyroid* 15(1):24, 2005.
12. **Hansen KA, Tho SPT, Hanly M, Moretuzzo RW, McDonough PG**, Massive ovarian enlargement in primary hypothyroidism, *Fertil Steril* 67:169, 1997.
13. **Wiseman SA, Powell JT, Humphries SE, Press M**, The magnitude of the hypercholesterolemia of hypothyroidism is associated with variation in the low density lipoprotein receptor gene, *J Clin Endocrinol Metab* 77:108, 1993.
14. **Golden SH, Robinson KA, Saldanha I, Anton B, Ladenson PW**, Clinical review: prevalence and incidence of endocrine and metabolic disorders in the United States: a comprehensive review, *J Clin Endocrinol Metab* 94:1853, 2009.
15. **Huber G, Staub J-J, Meier C, Mitrache C, Guglielmetti M, Huber P, Braverman LE**, Prospective study of the spontaneous course of subclinical hypothyroidism: prognostic value of thyrotropin, thyroid reserve, and thyroid antibodies, *J Clin Endocrinol Metab* 87:3221, 2002.
16. **Surks MI, Ortiz E, Daniels GH, Sawin CT, Col NF, Cobin RH, Franklyn JA, Hershman JM, Burman KD, Denke MA, Gorman C, Cooper RS, Weissman NJ**, Subclinical thyroid disease: scientific review and guidelines for diagnosis and management, *JAMA* 291:228, 2004.
17. **Monzani F, Caraccio N, Siciliano G, Manca L, Murri L, Ferrannini E**, Clinical and biochemical features of muscle dysfunction in subclinical hypothyroidism, *J Clin Endocrinol Metab* 82:3315, 1997.
18. **Monzani F, Del Guerra P, Caraccio N, Pruneti CA, Pucci E, Luisi M, Baschieri L**, Subclinical hypothyroidism: neurobehavioral features and beneficial effect of L-thyroxine treatment, *Clin Investig* 71:367, 1993.
19. **Kinlaw WB III**, Thyroid disorders and cholesterol: identifying the realm of clinical relevance, *Endocrinologist* 5:147, 1995.
20. **Danese MD, Ladenson PW, Meinert CL, Powe NR**, Effect of thyroxine therapy on serum lipoproteins in patients with mild thyroid failure: a quantitative review of the literature, *J Clin Endocrinol Metab* 85:2993, 2000.
21. **Caraccio N, Ferrannini E, Monzani F**, Lipoprotein profile in subclinical hypothyroidism: response to levothyroxine replacement, a randomized placebo-controlled study, *J Clin Endocrinol Metab* 87:1533, 2002.
22. **Hak AE, Pols HA, Visser TJ, Drexhage HA, Hofman A, Witteman JC**, Subclinical hypothyroidism is an

- independent risk factor for atherosclerosis and myocardial infarction in elderly women: the Rotterdam Study, *Ann Intern Med* 132:270, 2000.
23. **Cinemre H, Bilir C, Gokosmanoglu F, Bahcebasi T**, Iron deficiency anemia in patients with subclinical hypothyroidism benefits substantially by the addition of low-dose levothyroxine to iron replacement, as compared with iron replacement alone, *J Clin Endocrinol Metab* 94:1511, 2009.
  24. **Abalovich M, Gutierrez S, Alcaraz G, Maccallini G, Garcia A, Levalle O**, Overt and subclinical hypothyroidism complicating pregnancy, *Thyroid* 12:63, 2002.
  25. **Cooper DS**, Thyroid hormone treatment: new insights into an old therapy, *JAMA* 261:2694, 1989.
  26. **Toft AD**, Thyroxine therapy, *N Engl J Med* 331:174, 1994.
  27. **Walsh JP, Shiels L, Lim EM, Bhagat CI, Ward LC, Stuckey BGA, Dhaliwal SS, Chew GT, Bhagat MC, Cussons AJ**, Combined thyroxine/liothyronine treatment does not improve well-being, quality of life, or cognitive function compared to thyroxine alone: a randomized controlled trial in patients with primary hypothyroidism, *J Clin Endocrinol Metab* 88:4543, 2003.
  28. **Sawka AM, Gerstein HC, Marriott MJ, MacQueen GM, Joffe RT**, Does a combination regimen of thyroxine (T4) and 3,5,3'-triiodothyronine improve depressive symptoms better than T4 alone in patients with hypothyroidism? Results of a double-blind, randomized, controlled trial, *J Clin Endocrinol Metab* 88:4551, 2003.
  29. **Clyde PW, Harari AE, Getka EJ, Shakir KMM**, Combined levothyroxine plus liothyronine compared with levothyroxine alone in primary hypothyroidism: a randomized controlled trial, *JAMA* 290:2952, 2003.
  30. **Rosenbaum RL, Barzel US**, Levothyroxine replacement dose for primary hypothyroidism decreases with age, *Ann Intern Med* 96:53, 1982.
  31. **Demers LM, Spencer CA**, Laboratory medicine practice guidelines: laboratory support for the diagnosis and monitoring of thyroid disease, *Thyroid* 13:2, 2003.
  32. **Watts NB**, Use of a sensitive thyrotropin assay for monitoring treatment with levothyroxine, *Arch Intern Med* 149:309, 1989.
  33. **Lazarus JH**, Hyperthyroidism, *Lancet* 349:339, 1997.
  34. **Wallaschofski H, Kuwert T, Lohmann T**, TSH-receptor autoantibodies—differentiation of hyperthyroidism between Graves' disease and toxic multinodular goitre, *Exp Clin Endocrinol Diabetes* 112:171, 2004.
  35. **Sawin CT, Geller A, Wolf PA, Belanger AJ, Baker E, Bacharach P, Wilson PWF, Benjamin EJ, D'Agostino RB**, Low serum thyrotropin concentrations as a risk factor for atrial fibrillation in older persons, *N Engl J Med* 331:1249, 1994.
  36. **Sgarbi JA, Vilaça FG, Garbeline B, Villar HE, Romaldini JH**, The effects of early antithyroid therapy for endogenous subclinical hyperthyroidism in clinical and heart abnormalities, *J Clin Endocrinol Metab* 88:1672, 2003.
  37. **Cooper DS**, Approach to the patient with subclinical hyperthyroidism, *J Clin Endocrinol Metab* 92:3, 2007.
  38. **Franklyn JA**, The management of hyperthyroidism, *N Engl J Med* 330:1731, 1994.
  39. **Cooper DS**, Thyroid hormone and the skeleton, *JAMA* 259:3175, 1988.
  40. **Wartofsky L**, Osteoporosis and therapy with thyroid hormone, *Endocrinologist* 1:57, 1991.
  41. **Diamond T, Nery L, Hales I**, A therapeutic dilemma: suppressive doses of thyroxine significantly reduce bone mineral measurements in both premenopausal and postmenopausal women with thyroid carcinoma, *J Clin Endocrinol Metab* 72:1184, 1991.
  42. **Solomon BL, Wartofsky L, Burman KD**, Prevalence of fractures in postmenopausal women with thyroid disease, *Thyroid* 3:17, 1993.
  43. **Vestergaard P, Rejnmark L, Weeke J, Mosekilde L**, Fracture risk in patients treated for hyperthyroidism, *Thyroid* 10:341, 2000.
  44. **Foldes J, Tarjan G, Szathmary M, Varga F, Krasznai I, Horvath C**, Bone mineral density in patients with endogenous subclinical hyperthyroidism: is the thyroid status a risk factor for osteoporosis? *Clin Endocrinol* 39:521, 1993.
  45. **Bauer DC, Ettinger B, Nevitt MC, Stone KL**; for the **Osteoporotic Fractures Research Group**, Risk for fracture in women with low serum levels of thyroid-stimulating hormone, *Ann Intern Med* 134:561, 2001.
  46. **Barsony J, Lakatos P, Foldes J, Feher T**, Effect of vitamin D3 loading and thyroid hormone replacement

- therapy on the decreased serum 25-hydroxyvitamin D level in patients with hypothyroidism, *Acta Endocrinol* 113:329, 1986.
47. **Ross DS, Neer RM, Ridgway EC, Daniels GH**, Subclinical hyperthyroidism and reduced bone density as a possible result of prolonged suppression of the pituitary-thyroid axis with l-thyroxine, *Am J Med* 82:1167, 1987.
  48. **Faber J, Gallow AM**, Changes in bone mass during prolonged subclinical hyperthyroidism due to l-thyroxine treatment: a meta-analysis, *Eur J Endocrinol* 130:350, 1994.
  49. **Leese GP, Jung RT, Guthrie C, Waugh N, Browning MCK**, Morbidity in patients on l-thyroxine: a comparison of those with a normal TSH to those with a suppressed TSH, *Clin Endocrinol* 37:500, 1992.
  50. **Sheppard MC, Holder R, Fraklyn JA**, Levothyroxine treatment and occurrence of fracture of the hip, *Arch Intern Med* 162:338, 2002.
  51. **van den Eeden SK, Barzilay JI, Ettinger B, Minkoff J**, Thyroid hormone use and the risk of hip fracture in women  $\geq 65$  years: a case-control study, *J Womens Health (Larchmt)* 12:27, 2003.
  52. **Schneider DL, Barrett-Connor EL, Morton DJ**, Thyroid hormone use and bone mineral density in elderly women: effects of estrogen, *JAMA* 271:1245, 1994.
  53. **Mazzaferrri EL**, Management of a solitary thyroid nodule, *N Engl J Med* 328:553, 1993.
  54. **Smith JJ, Chen X, Schneider DF, Broome JT, Sippel RS, Chen H, Solórzano CC**, Cancer after thyroidectomy: a multi-institutional experience with 1,523 patients, *J Am Coll Surg* 216(4):571, 2013.
  55. **Pacini F, Fontanelli M, Fugazzola L, Elisei R, Romei C, Di Coscio G, Miccoli P, Pinchera A**, Routine measurement of serum calcitonin in nodular thyroid diseases allows the preoperative diagnosis of unsuspected sporadic medullary thyroid carcinoma, *J Clin Endocrinol Metab* 78:826, 1994.
  56. **Abalovich M, Amino N, Barbour LA, Cobin RH, De Groot LJ, Glinoe D, Mandel SJ, Stagnaro-Green A**, Management of thyroid dysfunction during pregnancy and postpartum: an Endocrine Society Clinical Practice Guideline, *J Clin Endocrinol Metab* 92(Suppl):S1, 2007.
  57. **Gharib H, Goellner JR**, Fine-needle aspiration biopsy of the thyroid: an appraisal, *Ann Intern Med* 118:282, 1993.
  58. **Glinoe D**, The regulation of thyroid function in pregnancy: pathways of endocrine adaptation from physiology to pathology, *Endocr Rev* 18:404, 1997.
  59. **Smyth PPA, Hetherington AMT, Smith DF, Radcliff M, O'Herlihy C**, Maternal iodine status and thyroid volume during pregnancy: correlation with neonatal iodine intake, *J Clin Endocrinol Metab* 82:2840, 1997.
  60. **Kennedy RL, Darne J**, The role of hCG in regulation of the thyroid gland in normal and abnormal pregnancy, *Obstet Gynecol* 78:298, 1991.
  61. **Ballabio M, Poshyachinda M, Ekins RP**, Pregnancy-induced changes in thyroid function: role of human chorionic gonadotropin as putative regulator of maternal thyroid, *J Clin Endocrinol Metab* 73:824, 1991.
  62. **Glinoe D, DeNayer P, Bourdoux P, Lemone M, Robyn C, Van Steirteghem A, Kinthaert J, Lejeune B**, Regulation of maternal thyroid during pregnancy, *J Clin Endocrinol Metab* 71:276, 1990.
  63. **Kimura M, Amino N, Tamaki H, Mitsuda N, Miyai K, Tanizawa O**, Physiologic thyroid activation in normal early pregnancy is induced by circulating hCG, *Obstet Gynecol* 75:775, 1990.
  64. **Kimura M, Amino N, Tamaki H, Ito E, Mitsuda N, Miyai K, Tanizawa O**, Gestational thyrotoxicosis and hyperemesis gravidarum: possible role of hCG with higher stimulating activity, *Clin Endocrinol* 38:345, 1993.
  65. **Berghout A, Ended E, Ross A, Hogerzeil HV, Smits NJ, Wiersinga WM**, Thyroid function and thyroid size in normal pregnant women living in an iodine replete area, *Clin Endocrinol* 41:375, 1994.
  66. **Dashe JS, Casey BM, Wells CE, McIntire DD, Byrd EW, Leveno KJ, Cunningham FG**, Thyroid-stimulating hormone in singleton and twin pregnancy: importance of gestational age-specific ranges, *Obstet Gynecol* 106:753, 2006.
  67. **American Thyroid Association Taskforce on Thyroid Disease During Pregnancy and Postpartum; Stagnaro-Green A, Abalovich M, Alexander E, Azizi F, Mestman J, Negro R, Nixon A, Pearce EN, Soldin OP, Sullivan S, Wiersinga W**, Guidelines of the American Thyroid Association for the diagnosis and management of thyroid disease during pregnancy and postpartum, *Thyroid* 21:1081, 2011.
  68. **De Groot L, Abalovich M, Alexander EK, Amino N, Barbour L, Cobin RH, Eastman CJ, Lazarus JH, Luton D, Mandel SJ, Mestman J, Rovet J, Sullivan S**, Management of thyroid dysfunction during

- pregnancy and postpartum: an Endocrine Society clinical practice guideline, *J Clin Endocrinol Metab* 97:2543, 2012.
69. **Calvo RM, Jauniaux E, Gulbis B, Asuncion M, Gervy C, Contempre B, Morreale de Escobar G**, Fetal tissues are exposed to biologically relevant free thyroxine concentrations during early phases of development, *J Clin Endocrinol Metab* 87:1768, 2002.
  70. **Davis LE, Leveno KL, Cunningham FG**, Hypothyroidism complicating pregnancy, *Obstet Gynecol* 72:108, 1988.
  71. **Leung AS, Millar LK, Koonings PP, Montoro M, Mestman JH**, Perinatal outcome in hypothyroid pregnancies, *Obstet Gynecol* 81:349, 1993.
  72. **Wasserstrum N, Anania CA**, Perinatal consequences of maternal hypothyroidism in early pregnancy and inadequate replacement, *Clin Endocrinol* 42:353, 1995.
  73. **Casey BM, Dashe JS, Wells CE, McIntire DD, Byrd W, Leveno KJ, Cunningham FG**, Subclinical hypothyroidism and pregnancy outcomes, *Obstet Gynecol* 105:239, 2005.
  74. **Negro R, Formoso G, Mangieri T, Pezzarossa A, Dazzi D, Hassan H**, Levothyroxine treatment in euthyroid pregnant women with autoimmune thyroid disease: effects on obstetrical complications, *J Clin Endocrinol Metab* 91:2587, 2006.
  75. **Goodwin TM, Montoro M, Mestman JH**, Transient hyperthyroidism and hyperemesis gravidarum: clinical aspects, *Am J Obstet Gynecol* 167:648, 1992.
  76. **Goodwin TM, Montoro M, Mestman JH, Pekary AE, Hershman JM**, The role of chorionic gonadotropin in transient hyperthyroidism of hyperemesis gravidarum, *J Clin Endocrinol Metab* 75:1333, 1992.
  77. **Yamazaki K, Sato K, Shizume K, Kanaji Y, Ito Y, Obara T, Nakagawa T, Koizumi T, Nishimura R**, Potent thyrotropic activity of human chorionic gonadotropin variants in terms of <sup>125</sup>I incorporation and de novo synthesized thyroid hormone release in human thyroid follicles, *J Clin Endocrinol Metab* 80:473, 1995.
  78. **Tsuruta E, Tada H, Tamaki H, Kashiwai T, Asahio K, Takeoka K, Mitsuda N, Amino N**, Pathogenic role of asialo human chorionic gonadotropin in gestational thyrotoxicosis, *J Clin Endocrinol Metab* 80:350, 1995.
  79. **Thorpe-Beeston JG, Nicolaidis KH, McGregor AM**, Fetal thyroid function, *Thyroid* 2:207, 1992.
  80. **Burrow GN, Fisher DA, Larsen PR**, Maternal and fetal thyroid function, *N Engl J Med* 331:1072, 1994.
  81. **Hume R, Simpson JL, Delahunty C, van Toor H, Wu SY, Williams FL, Visser TJ; Scottish Preterm Thyroid Group**, Human fetal and cord serum thyroid hormones: developmental trends and interrelationships, *J Clin Endocrinol Metab* 89:4097, 2004.
  82. **Leonard JL**, Non-genomic actions of thyroid hormone in brain development, *Steroids* 73:1008, 2008.
  83. **Hallengren B, Lantz M, Andreasson B, Grennert L**, Pregnant women on thyroxine substitution are often dysregulated in early pregnancy, *Thyroid* 19:391, 2009.
  84. **Benhadi N, Wiersinga WM, Reitsma JB, Vrijkotte TGM, Bonsel GJ**, Higher TSH levels in pregnancy are associated with increased risk for miscarriage, fetal or neonatal death, *Eur J Endocrinol* 160:985, 2009.
  85. **Maruo T, Katayama K, Matuso H, Anwar M, Mochizuki M**, The role of maternal thyroid hormones in maintaining early pregnancy in threatened abortion, *Acta Endocrinol* 127:118, 1992.
  86. **Haddow JE, Palomaki GE, Allan WC, Williams JR, Knight GJ, Gagnon J, O'Heir CE, Mitchell ML, Hermos RJ, Waisbren SE, Faix JD, Klein RZ**, Maternal thyroid deficiency during pregnancy and subsequent neuropsychological development of the child, *N Engl J Med* 341:549, 1999.
  87. **Klein RZ, Sargent JD, Larsen PR, Waisbren SE, Haddow JE, Mitchell ML**, Relation of severity of maternal hypothyroidism to cognitive development of offspring, *J Med Screen* 8:18, 2001.
  88. **Pop VJ, Kuijpers JL, van Baar AL, Verkerk G, van Son MM, de Vijlder JJ, Vuisma T, Wiersinga WM, Drexhage HA, Vader HL**, Low maternal free thyroxine concentrations during early pregnancy are associated with impaired psychomotor development in infancy, *Clin Endocrinol* 50:149, 1999.
  89. **Pop VJ, Brouwers EP, Vader HL, Vuisma T, Van Baar AL, de Vijlder JJ**, Maternal hypothyroxinaemia during early pregnancy and subsequent child development: a 3-year follow-up study, *Clin Endocrinol* 59:282, 2003.
  90. **Kooistra L, Crawford S, Van Baar AL, Brouwers EP, Pop VJ**, Neonatal effects of maternal hypothyroxinemia during early pregnancy, *Pediatrics* 117:161, 2006.



91. **American College of Obstetricians and Gynecologists**, ACOG Practice Bulletin No. 148: thyroid disease in pregnancy, *Obstet Gynecol* 125:996, 2015.
92. **American Society for Reproductive Medicine Practice Committee**, Subclinical hypothyroidism in the infertile female population: a guideline, *Fertil Steril* 104:545, 2015.
93. **Vaidya B, Anthony S, Bilous M, Shields B, Drury J, Hutchison S, Bilous R**, Detection of thyroid dysfunction in early pregnancy: universal screening or target high-risk case finding? *J Clin Endocrinol Metab* 92:203, 2007.
94. **Clearly-Goldman J, Malone FD, Lambert-Messerlian G, Sullivan L, Canick J, Porter TF, Luthy D, Gross S, Bianchi DW, D'Alton ME; for the FASTER Consortium**, Maternal thyroid hypofunction and pregnancy outcome, *Obstet Gynecol* 112:85, 2008.
95. **Glinoe D, Riahi M, Grun JP, Kinthaert J**, Risk of subclinical hypothyroidism in pregnant women with asymptomatic autoimmune thyroid disorders, *J Clin Endocrinol Metab* 79:197, 1994.
96. **Poppe K, Gilnoer D, Tournaye H, Devroey P, van Steirteghem A, Kaufman L, Velkeniers B**, Assisted reproduction and thyroid autoimmunity: an unfortunate combination? *J Clin Endocrinol Metab* 88:4149, 2003.
97. **Wolfberg A, Lee-Parritz A, Peller AJ, Lieberman E**, Obstetric and neonatal outcomes associated with maternal hypothyroid disease, *J Matern Fetal Neonatal Med* 17:35, 2005.
98. **Wikner BN, Sparre LS, Stiller C-O, Källén B, Asker C**, Maternal use of thyroid hormones in pregnancy and neonatal outcome, *Acta Obstet Gynecol Scand* 87:617, 2008.
99. **Mandel SJ, Larsen PR, Seely EW, Brent GA**, Increased need for thyroxine during pregnancy in women with primary hypothyroidism, *N Engl J Med* 323:91, 1990.
100. **Kaplan MM**, Monitoring thyroxine treatment during pregnancy, *Thyroid* 2:147, 1992.
101. **Alexander EK, Marqusee E, Lawrence J, Jarolim P, Fischer GA, Larsen PR**, Timing and magnitude of increases in levothyroxine requirements during pregnancy in women with hypothyroidism, *N Engl J Med* 351:241, 2004.
102. **Mandel SJ, Spencer CA, Hollowell JG**, Are detection and treatment of thyroid insufficiency in pregnancy feasible? *Thyroid* 15:44, 2005.
103. **McClain MR, Lambert-Messerlian G, Haddow JE, Palomaki GE, Canick JA, Clearly-Goldman J, Malone FD, Porter TF, Nyberg DA, Bernstein P, D'Alton ME, FaSTER Research Consortium**, Sequential first- and second-trimester TSH, free thyroxine, and thyroid antibody measurements in women with known hypothyroidism: a FaSTER trial study, *Am J Obstet Gynecol* 199:129.e1, 2008.
104. **LaFranchi S**, Congenital hypothyroidism: etiologies, diagnosis, and management, *Thyroid* 9:735, 1999.
105. **Salerno M, Militerni R, Bravaccio C, Micillo M, Capalbo D, Di MS, Tenore A**, Effect of different starting doses of levothyroxine on growth and intellectual outcome at four years of age in congenital hypothyroidism, *Thyroid* 12:45, 2002.
106. **Rovet JF, Ehrlich R**, Psychoeducational outcome in children with early-treated congenital hypothyroidism, *Pediatrics* 105:515, 2000.
107. **Rovet JF**, Children with congenital hypothyroidism and their siblings: do they really differ? *Pediatrics* 115:e52, 2005.
108. **Dimitropoulos A, Molinari L, Etter K, Torresani T, Lang-Muritano M, Jenni OG, Largo RH, Latal B**, Children with congenital hypothyroidism: long-term intellectual outcome after early high-dose treatment, *Pediatr Res* 65:2420248, 2009.
109. **Grüters A, Krude H, Biebermann H**, Molecular genetic defects in congenital hypothyroidism, *Eur J Endocrinol* 151(Suppl 3):U39, 2004.
110. **Al Taji E, Biebermann H, Limanová Z, Hniková O, Zikmund J, Dame C, Grüters A, Lebl J, Krude H**, Screening for mutations in transcription factors in a Czech cohort of 170 patients with congenital and early-onset hypothyroidism: identification of a novel PAX8 mutation in dominantly inherited early-onset non-autoimmune hypothyroidism, *Eur J Endocrinol* 156:521, 2007.
111. **Perelman AH, Johnson RL, Clemons RD, Finberg HJ, Clewell WH, Trujillo L**, Intrauterine diagnosis and treatment of fetal goitrous hypothyroidism, *J Clin Endocrinol Metab* 71:618, 1990.
112. **Shoham I, Aricha-Tamir A, Weintraub AY, Mazor M, Witztzer A, Holcberg G, Sheiner E**, Fetal heart

- rate tracing patterns associated with congenital hypothyroidism, *Am J Obstet Gynecol* 201:48.e1, 2009.
113. **Klein AH, Murphy BEP, Artal R, Oddie TH, Fisher DA**, Amniotic fluid thyroid hormone concentrations during human gestation, *Am J Obstet Gynecol* 136:626, 1980.
  114. **Davidson KM, Richards DS, Schatz DA, Fisher DA**, Successful in utero treatment of fetal goiter and hypothyroidism, *N Engl J Med* 324:543, 1991.
  115. **Glinoeer D**, The importance of iodine nutrition during pregnancy, *Public Health Nutr* 10:1541, 2007.
  116. **Miyata I, Abe-Gotyo N, Tajima A, Yoshikawa H, Teramoto S, Seo M, Kanno K, Sugiura K, Tanaka T, Eto Y**, Successful intrauterine therapy for fetal goitrous hypothyroidism during late gestation, *Endocr J* 54:813, 2007.
  117. **Roti E, Emerson CH**, Clinical review 29: postpartum thyroiditis, *J Clin Endocrinol Metab* 74:3, 1992.
  118. **Stagnaro-Green A**, Postpartum thyroiditis, *J Clin Endocrinol Metab* 87:4042, 2002.
  119. **Vargas MT, Bariones-Urbina R, Gladman D, Papsin FR, Walfish PG**, Antithyroid microsomal autoantibodies and HLA-DR5 are associated with postpartum thyroid dysfunction: evidence supporting an autoimmune pathogenesis, *J Clin Endocrinol Metab* 67:327, 1988.
  120. **Ando T, Davies TF**, Postpartum autoimmune thyroid disease: the potential role of fetal microchimerism, *J Clin Endocrinol Metab* 88:2965, 2003.
  121. **Alvarez-Marfany M, Roman SH, Drexler AZ, Robertson C, Stagnaro-Green A**, Long-term prospective study of postpartum thyroid dysfunction in women with insulin dependent diabetes mellitus, *J Clin Endocrinol Metab* 79:10, 1994.
  122. **Marqusee E, Hill JA, Mandel SJ**, Thyroiditis after pregnancy loss, *J Clin Endocrinol Metab* 82:2455, 1997.
  123. **Walfish PG, Chan YYC**, Postpartum hyperthyroidism, *Clin Endocrinol Metab* 14:417, 1985.
  124. **Kita M, Goulis DG, Avramides A**, Post-partum thyroiditis in a Mediterranean population: a prospective study of a large cohort of thyroid antibody positive women at the time of delivery, *J Endocrinol Invest* 25:513, 2002.
  125. **Davis LE, Lucas MJ, Hankins GDV, Roark ML, Cunningham FG**, Thyrotoxicosis complicating pregnancy, *Am J Obstet Gynecol* 160:63, 1989.
  126. **Millar LK, Wing DA, Leung AS, Koonings PP, Montoro MN, Mestman JH**, Low birth weight and preeclampsia in pregnancies complicated by hyperthyroidism, *Obstet Gynecol* 84:946, 1994.
  127. **Easterling TR, Chmucker BC, Carlson KL, Millard SP, Benedetti TJ**, Maternal hemodynamics in pregnancies complicated by hyperthyroidism, *Obstet Gynecol* 78:348, 1991.
  128. **Casey BM, Dashe JS, Wells CE, McIntire DD, Leveno KJ, Cunningham FG**, Subclinical hyperthyroidism and pregnancy outcomes, *Obstet Gynecol* 107:337, 2006.
  129. **Männistö T, Vaarasmaki M, Pouta A, Hartikainen AL, Ruokonen A, Surcel HM, Bloigu A, Järvelin MR, Suvanto-Luukkonen E**, Perinatal outcome of children born to mothers with thyroid dysfunction or antibodies: a prospective population-based cohort study, *J Clin Endocrinol Metab* 94:772, 2009.
  130. **Cheron RG, Kaplan MM, Larsen PR, Selenkow HA, Crigler JF Jr**, Neonatal thyroid function after propylthiouracil therapy for maternal Graves' disease, *N Engl J Med* 304:525, 1981.
  131. **Burrow GN, Klatskin EH, Genel M**, Intellectual development in children whose mothers received propylthiouracil during pregnancy, *Yale J Biol Med* 51:151, 1978.
  132. **Mitsuda N, Tamaki H, Amino N, Hosono T, Miyaki K, Tanizasa O**, Risk factors for developmental disorders in infants born to women with Graves' disease, *Obstet Gynecol* 80:359, 1992.
  133. **Wing DA, Millar LK, Koonings PP, Montoro MN, Mestman JH**, A comparison of propylthiouracil versus methimazole in the treatment of hyperthyroidism in pregnancy, *Am J Obstet Gynecol* 170:90, 1994.
  134. **Wenstrom KD, Weinger CP, Williamson RA, Grant SS**, Prenatal diagnosis of fetal hyperthyroidism using funipuncture, *Obstet Gynecol* 76:513, 1990.
  135. **Cohen O, Pinhas-Haniel O, Sivan E, Dolitski M, Lipitz S, Achiron R**, Serial in utero ultrasonographic measurements of the fetal thyroid: a new complementary tool in the management of maternal hyperthyroidism in pregnancy, *Prenat Diagn* 23:740, 2003.
  136. **Luton D, Le Gac I, Vuillard E, Castanet M, Guibourdenche J, Noel M, Toubert ME, Léger J, Boissinot C, Schlageter MH, Garel C, Tébeke B, Oury JF, Czernichow P, Polak M**, Management of Graves' disease during pregnancy: the key role of fetal thyroid gland monitoring, *J Clin Endocrinol Metab*

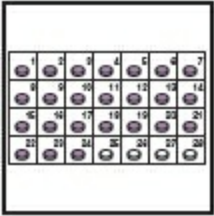
90:6093, 2005.

# CONTRACEPTION

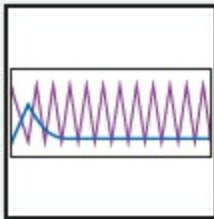
---



**Chapter 21:** Family Planning, Sterilization, and Abortion



**Chapter 22:** Hormonal Contraception



**Chapter 23:** Long-Acting Methods of Contraception



**Chapter 24:** Barrier Methods of Contraception and Withdrawal

# Family Planning, Sterilization, and Abortion

The era of modern contraception in the United States dates from 1960 when intrauterine devices (IUDs) were reintroduced and oral contraception was first approved by the Food and Drug Administration. It took 12 years after this approval for the social and legal climate in the United States to change enough to allow for widespread access to contraception. In 1961, the Connecticut Planned Parenthood Executive Director Estelle Griswold and the Yale Department of Obstetrics and Gynecology Chair C. Lee Buxton opened a birth control clinic in New Haven, thus publicly challenging a state law prohibiting the prescribing of contraceptives; both were arrested and convicted. Appeals went to the supreme court where contraception rights were established. In 1965, **Griswold versus Connecticut** allowed for married women to have access to contraceptives by arguing that the right to contraception fell under the right to privacy protected by the due process clause in the 14th amendment. This partially overturned the Comstock Laws passed in 1873 that were designed to ban distribution of contraception. A complete overturn of the Comstock Laws in relation to contraception distribution happened in 1972 when **Eisenstadt versus Baird** extended access to nonmarried persons. National family planning services and research began to be funded by the U.S. Congress in 1970.

An estimated 42% of pregnancies in North America and 40% of pregnancies worldwide are unintended.<sup>1</sup> This is indicative of a need for improved family planning initiatives. Additionally, the teen pregnancy rate in the United States is 57 per 1,000 female adolescents, while in other developed countries, the teen pregnancy rate varies from 47 (England and Wales) to 8 (Sweden) pregnancies per 1,000 female adolescents.<sup>2</sup> About 75% of all pregnancies among American teenagers are unintended.<sup>3</sup> Increasing effective contraceptive use among young Americans began to have an impact in 1991 and decreases in teen birth rates in the United States continued through 2015 for a 61% decline overall, most recently dropping 8% from 2014 to 2015.<sup>2,4,5</sup> From 1995 to 2002, 14% of the decline in teen pregnancy was a consequence of decreased sexual activity among US teenagers; however, 86% of the decline was attributed to an increase in the use of effective contraception.<sup>6</sup>

In recent years, fewer teens have received instruction regarding contraception.<sup>7</sup> The

evidence overwhelmingly indicates that abstinence programs have **not** had a positive impact on teen sexual behavior, including the delay of the initiation of sex or the number of sexual partners.<sup>8</sup> In contrast, comprehensive sex education programs that include contraception are effective and do not increase the frequency of sex or hasten the initiation of sexual activity.<sup>9</sup>

Of the unplanned pregnancies in the United States, about 39–42% are aborted.<sup>1,3</sup> American teenagers abort 26–38% of their pregnancies, which is a decrease from the mid-1990s when about 50% of adolescent pregnancies were aborted.<sup>2,3</sup> Unintended pregnancies in American females aged 20–34 have a higher rate of abortion, between 42% and 44%. The unintended pregnancy rate for American females aged 20–30 is 66–81 per 1,000 females.<sup>3</sup> In other developed countries, the unintended pregnancy rate for all age ranges is 44 per 1,000 females.<sup>1</sup> American women older than 35 aborted 46% of unintended pregnancies from 2008 to 2011, the highest rate of any age group.<sup>3</sup> The unintended pregnancy rate for this population is 16 per 1,000 females. Despite Americans having higher rates of unintended pregnancy than other developed countries, this number is decreasing. From 2008 to 2011, unintended pregnancy rates decreased by 18% overall.<sup>3</sup>

This decrease in unintended pregnancy in the United States may be partially attributable to the Affordable Care Act, which in 2010 enacted legislation requiring contraceptive coverage for women. The biggest change in contraception in the United States before and after 2010 is the increased use of long-acting reversible contraceptive (LARC) use. Between 2009 and 2012, LARC use in the United States increased significantly, from 8.5% to 11.6%.<sup>10</sup> Currently, 62% of all reproductive-aged women in the United States use a contraceptive method. Ninety percent of all women at risk of unintended pregnancy (those who are sexually active and not desiring pregnancy) use a contraceptive method.<sup>11</sup> Use of oral contraceptives, female sterilization, male condom, male sterilization, withdrawal, injectables, contraceptive rings or patches, and the rhythm method have all remained fairly consistent before and after 2010.<sup>12</sup>

Compared to other countries, such as the United Kingdom, where 82.3% of all women of reproductive age use contraception, women in the United States are at a higher risk of unintended pregnancy.<sup>13</sup> The gap in contraceptive use by American women as compared to their peers in other developed countries has been posited as an access issue, attributable to the availability of contraception, rather than a difference in sexual activity or experience. In other developed countries, contraceptive services can be obtained from more accessible resources and relatively inexpensively. Additionally, the diversity of the American people in both belief system and wealth distribution makes it difficult to implement sex education and affordable contraceptive service

providers. Time will tell if more affordable access to contraceptives in the United States leads to increased use and a decrease in unintended pregnancies.

# EFFICACY OF CONTRACEPTION

---

A clinician's anecdotal experience with contraceptive methods is truly insufficient to provide the accurate information necessary for patient counseling. The clinician must be aware of the definitions and measurements used in assessing contraceptive efficacy and must draw on the talents of appropriate experts in this area to summarize the accurate and comparative failure rates for the various methods of contraception. The publications by Trussell et al., summarized below, accomplish these purposes and are highly recommended.<sup>14,15,16,17</sup>



# Definition and Measurement

Contraceptive efficacy is generally assessed by measuring the number of unplanned pregnancies that occur during a specified period of exposure and use of a contraceptive method. The two methods that have been used to measure contraceptive efficacy are the Pearl Index and life-table analysis.

## The Pearl Index

The Pearl Index, created by Raymond Pearl in 1933, is defined as the number of failures per 100 woman-years of exposure.<sup>18</sup> The denominator is the total months or cycles of exposure from the onset of a method until completion of the study, an unintended pregnancy, or discontinuation of the method. The quotient is multiplied by 1,200 if the denominator consists of months or by 1,300 if the denominator consists of cycles.

With most methods of contraception, failure rates decline with duration of use. The Pearl Index is usually based on a lengthy exposure (usually 1 year) and, therefore, fails to accurately compare methods at various durations of exposure. This limitation is overcome by using the method of life-table analysis.

## Life-Table Analysis

Life-table analysis calculates a failure rate for each month of use. A cumulative failure rate can then compare methods for any specific length of exposure. Women who leave a study for any reason other than unintended pregnancy are removed from the analysis, contributing their exposure until the time of the exit.

# Contraceptive Failures

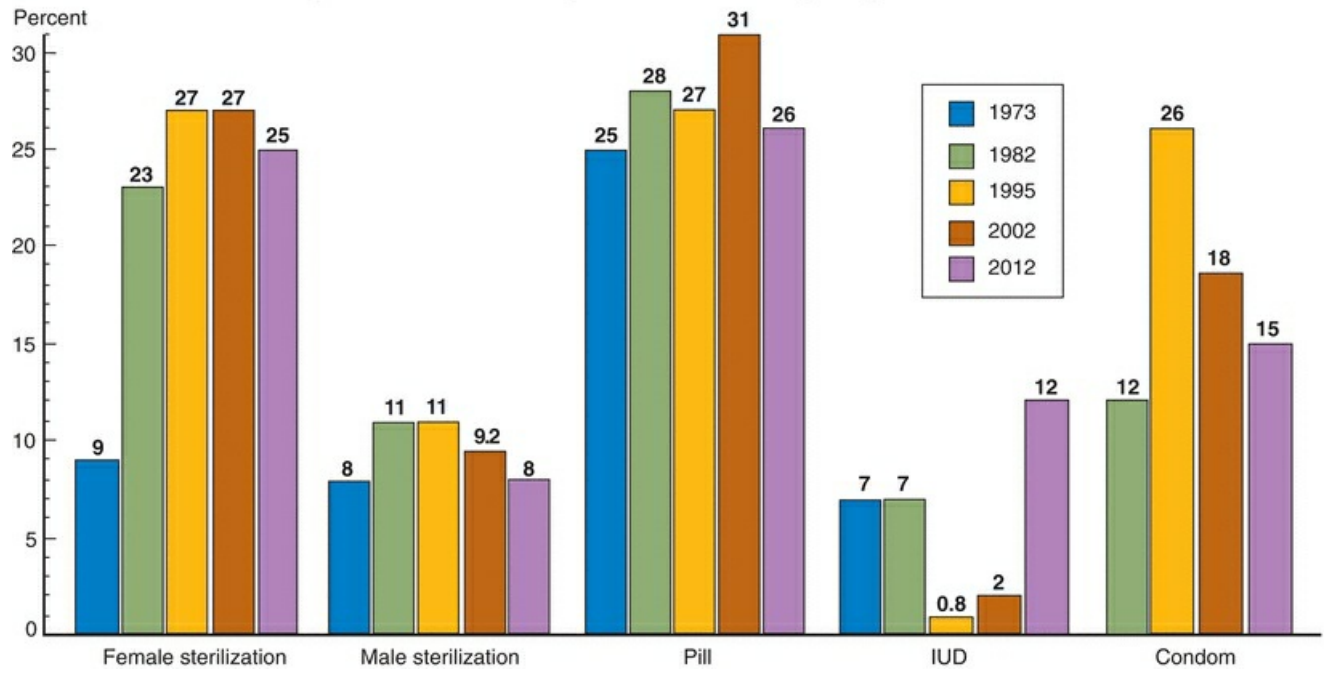
Contraceptive failures do occur and for many reasons. Thus, “method effectiveness” and “use effectiveness” have been used to designate efficacy with correct and incorrect use of a method. It is less confusing to simply compare the very best performance (the lowest expected failure rate) with the usual experience (typical failure rate) as noted in the table of failure rates during the 1st year of use. The lowest expected failure rates are determined in clinical trials, in which the combination of highly motivated subjects and frequent support from the study personnel yields the best results. Contraceptive typical failure rates have been estimated using the data from the 1995 and 2002 U.S. National Survey of Family Growth, correcting for the underreporting of induced abortion.<sup>17,20</sup>

These more recent estimates were not significantly different compared with the previous estimates from the 1995 national survey. Women over the age of 30 were less likely to experience failure than young women; teens were more than twice as likely to experience a failure than older women. Hispanic women and Black women experienced higher failure rates. Groups that were less likely to experience contraceptive failure were women who did not intend to have a subsequent birth and women who had no previous births. Married women experienced the lowest failure rates and women cohabiting with a male partner the highest. The most important determinants of contraceptive pill failure were age, intention toward a future birth, parity, and marital status. Interestingly, once these factors were accounted for, duration of use, race, ethnicity, and poverty status no longer affected the risk of pill failure. The same factors influence condom use, but when corrected for these factors, race, ethnicity, and poverty affected the risk of condom failure (Table 21.1, Figure 21.1).

## **TABLE 21.1 Failure Rates During the First Year of Use, United States<sup>15,16,17</sup>**

Method	Percent of Women with Pregnancy	
	Lowest Expected	Typical
No method	85%	85%
Combination pill	0.3%	8.7%
Progestin only	0.5%	3.0%
IUDs		
Levonorgestrel IUD	0.1%	0.1%
Copper T 380A	0.6%	1.0%
Implant	0.05%	1.0%
Injectable		
3 mo	0.3	0.3%
1 mo	0.05	3.0%
Patch	0.3	8.0%
Vaginal ring	0.3	8.0%
Female sterilization	0.5%	0.7%
Male sterilization	0.1%	0.2%
Spermicides	18.0%	29.0%
Periodic abstinence		25.3%
Calendar	9.0%	
Ovulation method	3.0%	
Symptothermal	2.0%	
Postovulation	1.0%	
Withdrawal	4.0%	18.4%
Cervical cap		
Parous women	26.0%	32.0%
Nulliparous women	9.0%	16.0%
Sponge		
Parous women	20.0%	32.0%
Nulliparous women	9.0%	16.0%
Diaphragm and spermicides	6.0%	16.0%
Condom		
Male	2.0%	17.4%
Female	5.0%	27.0%

### Changes in Methods by U.S. Contracepting Women 15–44<sup>12,19,20</sup>



**FIGURE 21.1**

# CONTRACEPTIVE USE IN THE UNITED STATES

---

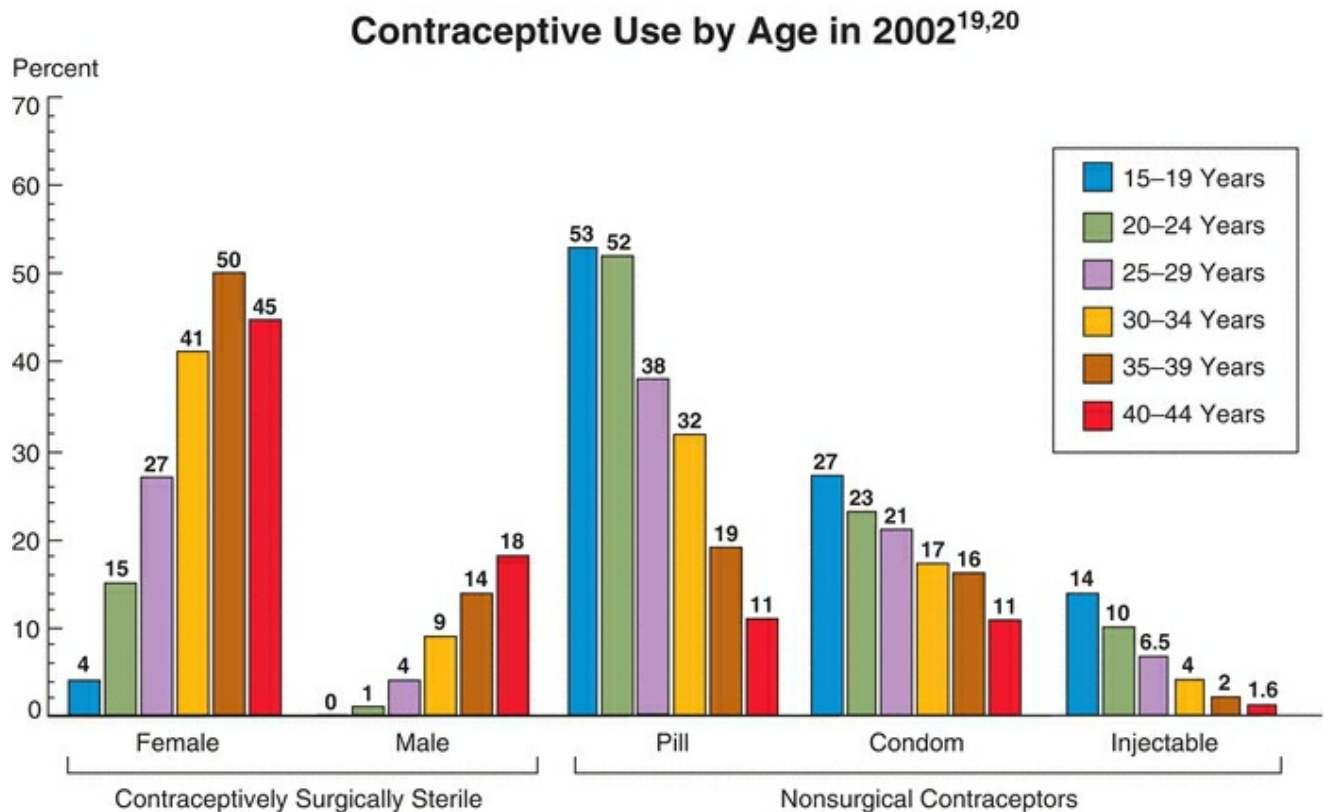
The National Survey of Family Growth is conducted by the National Center for Health Statistics of the Centers for Disease Control and Prevention. Data are available from 1972, 1976, 1982, 1988, 1995, 2002, 2006–2010, and 2011–2013.<sup>12,19,20,21,22,23,24</sup> The samples are very large; therefore, the estimates are very accurate.

Pregnancy rates in the 1990s declined for women in their 20s by 8% and increased in women in their 30s by 3%. The percent of married couples using sterilization as a method of contraception more than doubled from 1972 to 1988 and has remained stable since then. The use of oral contraception reached a high in 1992, slightly decreased in 1995, especially among Hispanic and Black Americans, and has remained around approximately 27% since then. Among never-married women, heterosexual cohabiting women, and women under age 25, oral contraception is the leading method of birth control. Approximately 49% of contracepting women under age 25 were using oral contraception between 2006 and 2010. From 1988 to 2002, oral contraception use rose to 32% of contraceptors aged 30–34 and 11% of those aged 40–44. By the 2010 data point, this had decreased to 25% and 9% of contraceptors, respectively. About 3.7% of contraceptors in 2010 were using the 3-month injectable method, and 3.5% were using transdermal, vaginal ring, and implant methods.

In the 1990s, there was an increase in condom use by never-married and formerly married women, women younger than 25, Black women, and Hispanic women. These changes reflected the concern regarding sexually transmitted infections (STIs), including human immunodeficiency virus (HIV). But in 2002, the use of condoms alone returned to the level observed in the 1980s, probably because of the use of transdermal, vaginal ring, implant, and injectable methods. About one-third of condom users in 2002 were using more than one method, especially younger and never-married women, including the use of an oral contraceptive and a condom in 14% at first intercourse! Most importantly, the percentage of women who used a contraceptive method at their first premarital intercourse increased from 43% before 1980 to 79% in 2002. Condom use at first intercourse increased from 22% before 1980 to 67% in 2002.

In 1982, 56% of US women, 15–44 years of age, were using contraception, and this has increased to 62%. In 2010, contraceptive sterilization (male and female) was utilized by 37% of contraceptors (the next leading method was oral contraception, 28%). The number of reproductive-aged women using the IUD nadired in 1995 at 0.8%, but has risen to 11.6% in 2012. IUD use was traditionally higher in married women over 35, but is more prevalent in younger populations now. In 1982, about 8% of contraceptors used the diaphragm, but use of the diaphragm has nearly disappeared in

the United States (0.1% of contracepting women in 2010) ([Figure 21.2](#)).



**FIGURE 21.2**

The oral contraceptive pill (47%) and condoms (21%) are the most popular methods of contraception among teenagers. However, studies have repeatedly documented that the use of the implant, injectable methods, and IUDs is associated with lower discontinuation rates and a lower rate of repeat pregnancies following delivery.<sup>25,26,27,28</sup> This warrants continuing efforts to extend the use of these methods to younger age groups.

In 2013, 62% of all women 15–44 years of age were using some method of contraception, whereas 38% of women of reproductive age were not using a method of contraception for the following reasons:

- 19%—Not sexually active
- 9.5%—Pregnant or trying to get pregnant
- 2.2%—Male and female sterility
- 1%—Sterilized for medical reasons

## 7%—At risk for an unintended pregnancy

The women at risk for an unintended pregnancy accounted for more than half of unintended pregnancies in the United States. Of the rest, about 43% are a consequence of incorrect contraceptive use; only 5% can be attributed to method failure.<sup>12,17</sup> In our view, these numbers reflect problems of contraceptive access, affordability, and correct use in the United States. The number of unintended pregnancies is highest among low-income women, women aged 15–24, unmarried women, and members of racial or ethnic minority groups.<sup>3</sup>

US couples have made up for the lack of contraceptive effective use and availability by greater reliance on voluntary sterilization. Between 1973 and 1982, oral contraception and sterilization changed places as the most popular contraceptive method among women over the age of 30. Approximately one-half of American couples choose sterilization within 15–20 years of their last wanted birth. During the years of maximal fertility, oral contraceptives are the most common method peaking at age 20–24. The use of condoms is the second most widely used method of reversible contraception, rising from about 9% in the mid-1980s to approximately 26% of contracepting women in 1995, decreasing to 15% in 2013.<sup>12,20</sup>

Overall use of contraception among women at risk of unintended pregnancy decreased from 92.5% in 1995 to 89.9% in 2013.<sup>12</sup> The use of contraception among poor women at risk of pregnancy decreased from 92.1% in 1995 to 86.3% in 2002. Women at or below the poverty line rely on sterilization for contraception (40.9% of contraceptors) more heavily than do women above it or compared to those with private insurance (22.3%). For various reasons, American women have a history of difficulty in obtaining effective contraception.

Women at each end of the economic spectrum, the poorest and the wealthiest, experienced a decrease in failure rates from 1995 to 2002, although the poorest women continued to have a higher failure rate than did the better-off women. Although the difference in overall failure rate was not statistically significant between 1995 and 2002, there was about a 2.5% improvement. This change is probably due to an increase in pill and injectable method use and a decrease in condom use during this period of time. Women living in poverty who must rely on condoms or withdrawal (male-dependent methods) have about a twofold increase in failure rates, but if they can use the pill, their failure rates are the same as those of better-off women. The message is clear: we need to make the more effective contraceptive methods available for poor women.

What do women have to do to achieve good contraceptive efficacy or to switch to a more effective one? Choices must be available for various methods. The method of

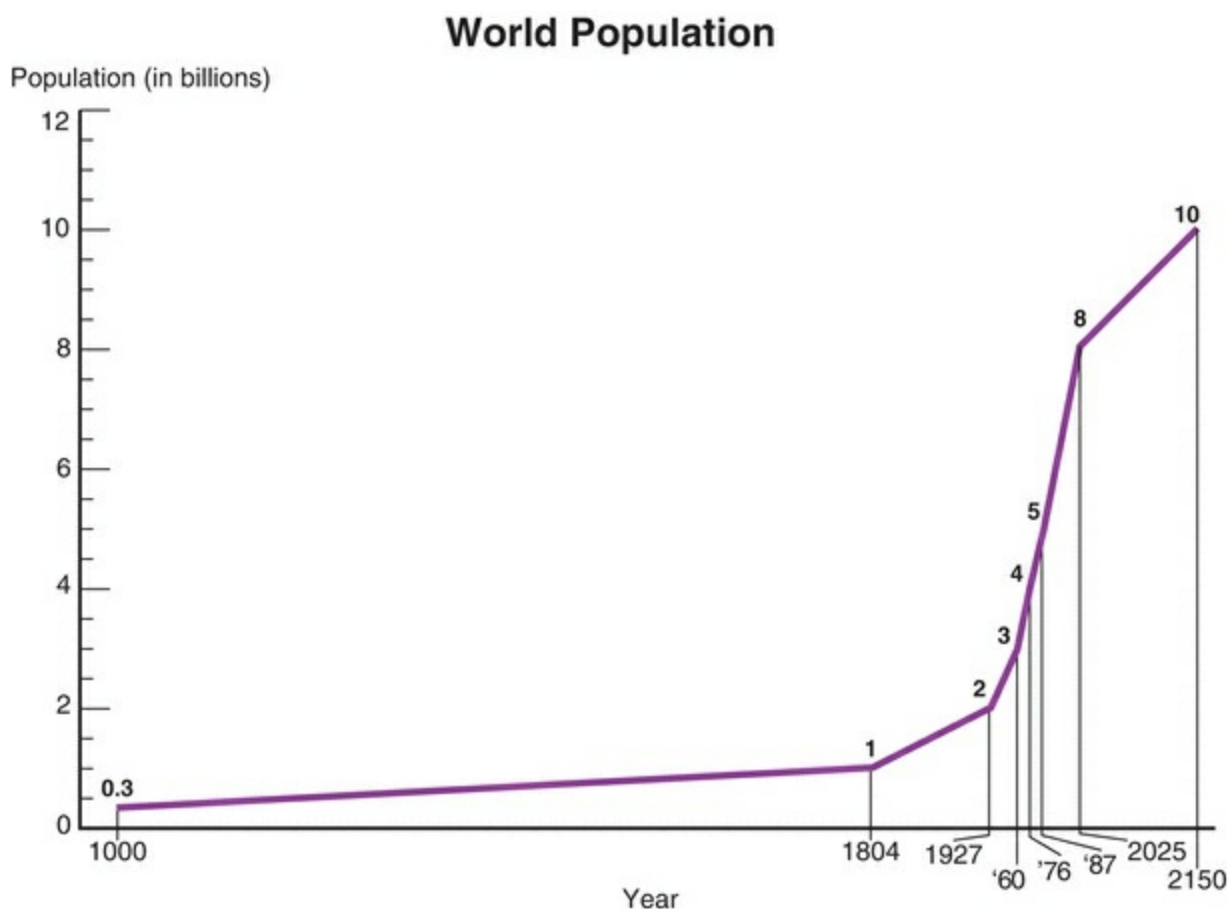
choice must be compatible with an individual and her lifestyle. Some methods require partner cooperation. Once chosen and obtained, the individual must exert dedication to its use. Increase in IUD usage from 2009 to 2012, the Affordable Care Act, and a small increase in couples actively desiring pregnancy may all contribute to the decrease in unintended pregnancy rate from 2009 to 2013. However, the United States still has room to improve in order to decrease unintended pregnancy rates to a level comparable to other developed countries. This will depend on improvements in contraceptive education to Americans and further policy changes.

The pattern of contraceptive use in Canada is similar to that of the United States, with a similar percentage of oral contraceptive use (about 44% of women 15–44 years of age), higher use of male condoms (54%), and a lower use of IUDs (4.3%) and sterilization (7%).<sup>29</sup> In England, the primary method of contraception is oral contraception (28%) followed by condoms (24%), the IUD (4%), and injectable methods (3%); 7% of the reproductive-aged women and 10% of the men have been sterilized.<sup>30</sup> In France, 41% of reproductive-aged women use oral contraceptives. IUD use is increasing in France in all ages between 2010 and 2013. In women aged 20–24, 5% use this method, and in women aged 25–29, 16% use IUDs.<sup>31</sup>



# THE IMPACT OF THE WORLDWIDE USE OF CONTRACEPTION

The world population is expected to stabilize at above 10 billion after 2180, with a fertility rate of 2.1 children per woman.<sup>32</sup> Approximately 96% of the population growth now occurs in developing countries, so that by 2050, 10% of the population will live in developed countries, a decrease from the current 25%. Today, the fertility rate is about 1.6–1.9 children per women in Eastern and Western Europe, North America, Japan, Australia, and New Zealand.<sup>33</sup> Sometime after 2020, all of the growth in global population will occur in developing countries (**Figure 21.3**).



**FIGURE 21.3**

Throughout the world, 63% of married women of reproductive age practice contraception. However, there is significant variation from area to area, for example, more than 75% in the United States but only 15% in Nigeria, one of the fastest growing countries.<sup>33</sup> About 225 million women living in developing countries are at risk of an

unplanned pregnancy.<sup>34</sup> The 76% of the world's population living in developing countries account for:

- 85% of all births
- 95% of all infant and childhood deaths
- 99% of all maternal deaths

In the developing world, maternal morbidity and mortality are real risks. The ability to regulate fertility has a significant impact on infant, child, and maternal mortality and morbidity. A pregnant woman has an 80 times greater chance of dying if she lives in a developing country rather than in a developed country.<sup>35</sup> The health risks associated with pregnancy and childbirth in the developing world are far greater than risks secondary to the use of modern contraception.

In recent years, there has been an appropriate shift from a narrow focus on contraception to a broader view that encompasses the impact of poverty, emphasizes overall well-being and the rights of individuals, endorses gender equality, and examines the interactions among these issues.

# THE IMPACT OF USE AND NONUSE

---

Inadequate access to contraception is associated with a high induced abortion rate. Effective contraceptive use largely, although not totally, replaces the resort to abortion. The combination of restrictive abortion laws and the lack of safe abortion services continues to make unsafe abortion a major cause of morbidity and mortality throughout the world, especially in many developing countries where abortion services are illegal.<sup>35,36</sup> Both safe and unsafe abortions can be minimized by maximizing contraceptive services. However, the need for safe abortion services will persist because contraceptive failures account for about half of the 1.2 million annual induced abortions in the United States.<sup>37</sup>

In the United States, money spent on public funding for family planning saves money spent on medical, welfare, and nutritional services.<sup>38,39</sup> States with higher family planning expenditures have fewer induced abortions, low-birth weight newborns, and premature births.<sup>40</sup> The investment in family planning leads to short-term reductions in expenditures on maternal and child health services and, after 5 years, a reduction in costs for education budgets. It was estimated that for every government dollar spent on contraceptive services, \$7.09 was saved.<sup>38</sup> Cutting back on publicly funded family planning services largely affects poor women, increasing the number of unintended births and abortions.

# SEXUALLY TRANSMITTED INFECTIONS AND CONTRACEPTION

---

The interaction between clinician and patient for the purpose of contraception provides an opportunity to control STIs. The modification of unsafe sexual practices reduces the risk of unplanned pregnancy and the risk of infections of the reproductive tract. A patient visit for contraception is an excellent time for STI screening; if an infection is symptomatic, it should be diagnosed and treated during the same visit in which contraception is requested. A positive history for STIs should trigger both screening for asymptomatic infections and counseling for safer sexual practices. Attention should be given to the contraceptive methods that have the greatest influence on the risk of STIs.

# THE ENVIRONMENT AND CONTRACEPTION

---

In the midst of politics and philosophy heavily promoting a “green” effort to limit global warming, a very important point is being ignored. **Even small increases in population have a major impact on the global environment, including excessive consumption of resources in affluent societies.**

Thomas Robert Malthus, an English clergyman, mathematician, and political economist, published six editions of his famous book, **An Essay on the Principle of Population**, between the years 1798 and 1826. The Malthusian hypothesis can be expressed very simply: the human population will outgrow the world’s resources needed for its support. Malthus argued that population could be controlled only by a high death rate or a low birth rate. Overpopulation would lead to poverty, an animalistic competition for food, and a general loss of civilization.

The Malthusian hypothesis has been resurrected in recent times. There is a growing awareness that our planet has a limited amount of clean air, potable water, and specific agricultural and mineral commodities, but an ever-growing population. Optimists look to the power of technology and human creativity to solve this Malthusian problem, but the acute need for effective contraception cannot be ignored. Effective family planning programs benefit not only individuals but also national economies and the global environment. The need and demand for family planning are extant in every part of our world, although greatest in the developing countries. Lacking is the required political and financial commitment.

# CONTRACEPTION AND LITIGATION

---

Clinicians are concerned about the prospect of bad outcomes associated with contraceptive use leading to litigation. Multimillion dollar verdicts and settlements in favor of plaintiffs who have used products as innocent as spermicides capture national attention. Actually, these events are very unusual compared with the widespread use of contraception.

The best way to avoid litigation is good patient communication. Patients who sue usually claim there were contraindications or risks that were not conveyed by the clinician. The best way to influence litigation is to keep good records. Good clinician's records are the most formidable weapon for the defense. Documentation is vital, but it is useless without thorough history taking. Good records and good history taking put the responsibility on the patient's honesty in response to the clinician.

**Document that the risks and benefits of all methods were discussed.**

**Document a plan for follow-up.**

**Document all interactions with the patient, including phone calls.**

# THE FUTURE

From 1970 to 1986, the number of births in women older than 30 quadrupled; from 1990 to 2005, the fertility rate among women older than 30 remained relatively stable, but in 2005 and 2006, the birth rates for women over 30 and for women over 40 increased.<sup>20,21,24</sup> As couples deferred pregnancy until later in life, the use of sterilization under age 35 declined, and the need for reversible contraception increased.

Until 2005, the highest number of births in the United States occurred between 1947 and 1965—the post–World War II baby boom (a demographic phenomenon shared by all parts of the developed world). The entire cohort of women born in this period reached their 45th birthday around 2010. We have experienced, therefore, an unprecedented number of women in the later childbearing years. This group of women not only increased in number but changed its fertility pattern.

The deferment of marriage is a significant change in our society. However, only a small percentage of the decline in the total fertility rate is accounted for by the increase in the average age at first marriage. Most of the decline in total fertility rate is accounted for by changes in marital fertility rates. In other words, postponement of pregnancy in marriage is the more significant change. This combination of increasing numbers, deferment of marriage, and postponement of pregnancy in marriage is responsible for the fact that we are seeing more older women who need reversible contraception. In short, there will continue to be longer duration of contraceptive use in younger women and greater use in older women, a pattern that began in 1990 (Table 21.2).

**TABLE 21.2 Change in U.S. Female Demographics 1980–2010<sup>5,160</sup>**

Age	1980	1990	2000	2005	2010	% Change 1980–2010
15–24	21 million	18.1 million	19.1 million	20.6 million	20.9 million	–0.4%
25–34	18.7	21.6	19.7	19.9	20.3	+8.6
35–44	13.1	18.9	22.7	21.8	20.6	+57.3
Total 15–44	52.8	58.6	61.5	62.3	61.8	+17

Fortunately, clinicians and patients recognized that low-dose steroid contraception is very safe for healthy, nonsmoking, older women. Between 1988 and 1995, the use of oral contraceptives doubled among women aged 35–39 and increased sixfold in women

older than age 40.<sup>23</sup> However, as the previously mentioned statistics indicate, its use is still not sufficient to meet the need. In addition to fulfilling a need, this population of women has a series of benefits to be derived from steroid contraception that tilt the risk/benefit ratio to the positive side ([Chapter 22](#)).

The growing need for reversible contraception would also be served by increased use of the IUD. A return to IUD use by American couples is both warranted and desirable.

A major problem in the United States is the prevalence of misconceptions. More than half of women, even well-educated women, are not accurately aware of the efficacy or the benefits and side effects associated with contraception.<sup>41, 42, 43, 44</sup> Unfortunately, a significant percentage of women still do not know that there are many health benefits with the use of steroid contraception. Misconceptions regarding contraception have, in many instances, achieved the stature of myths. Myths are an obstacle to good utilization and can only be dispelled by accurate and effective educational efforts.

Contraceptive advice is a component of good preventive health care. The clinician's approach to contraceptive counseling is key. While this is an era of informed choice by the patient, there is no doubt that patients, especially young patients, are influenced in their choice by their clinicians' advice and attitude. Although the role of a clinician is to provide the education necessary for the patient to make proper choices, one should not lose sight of the powerful influence exerted by the clinician in the choices ultimately made. In the 1970s, we approached the patient with great emphasis on risk. In the 1990s, studies effectively documented the risks and benefits of contraception. Now, counseling the patient should highlight the benefits and the greater safety of appropriate contraception.



# STERILIZATION

---

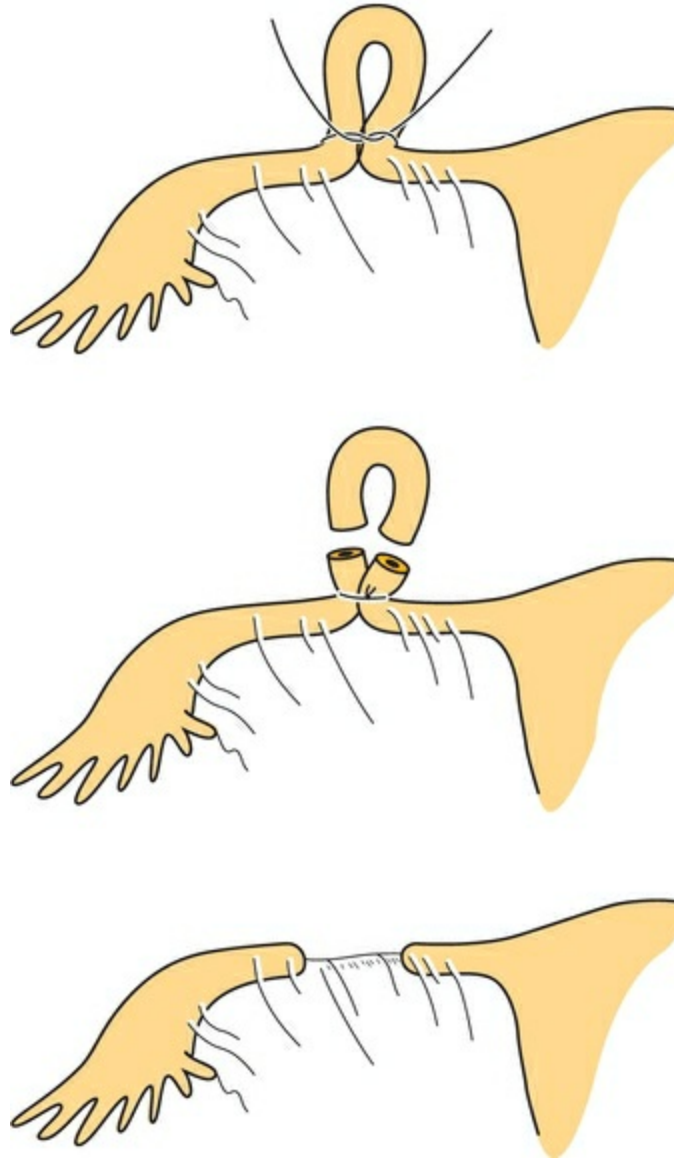
Contraceptive methods today are very safe and effective; however, we remain decades away from a perfect method of contraception for either women or men. Because reversible contraceptive methods are not perfect, more than a fourth of American couples use sterilization instead, and sterilization is now the predominant method of contraception in the world, with 222 million women relying on it for their method of family planning.<sup>45</sup>

Over the past 20 years, over 1 million Americans each year have undergone a sterilization operation, more women than men. Currently, 20% of reproductive-aged American women (33% of American women who use contraception) rely on contraceptive sterilization: 25% undergo tubal occlusion, and 8% depend on their partners' vasectomies.<sup>11</sup> Similarly in Great Britain, more than 32% of men and women have had a sterilization procedure.<sup>45</sup>

# History

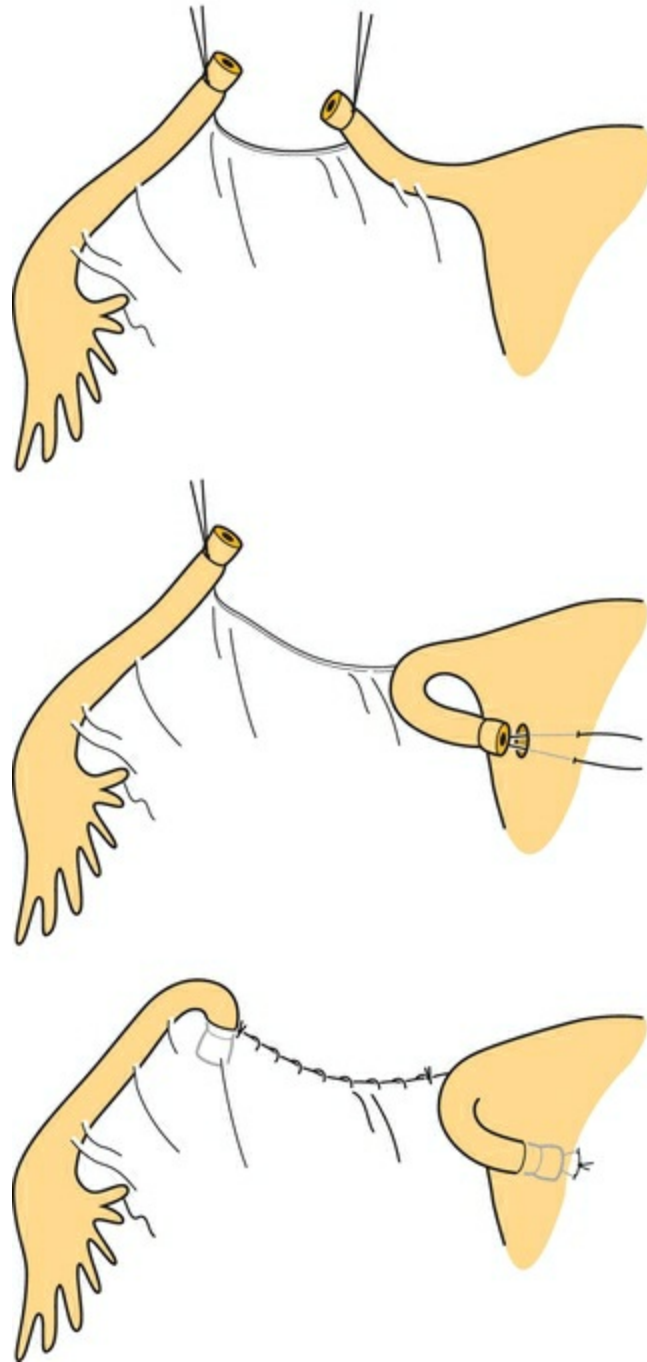
James Blundell proposed in 1823, in lectures at Guy's Hospital in London, that tubectomy ought to be performed at cesarean section to avoid the need for repeat sections.<sup>46</sup> He also proposed a technique for sterilization, which he later described so precisely that most believe he performed the operation. The first report was published in 1881 by Samuel Lungren of Toledo, Ohio, who ligated the tubes at the time of cesarean section, as Blundell had suggested 58 years earlier.<sup>47</sup> The Madlener procedure was devised in Germany in 1910 and reported in 1919. Because of many failures, the Madlener technique was supplanted in the United States by the method of Ralph Pomeroy, a prominent physician in Brooklyn, New York (**Figure 21.4**). This method, still popular today, was not described to the medical profession by Pomeroy's associates until 1929, 4 years after Pomeroy's death. Frederick Irving of the Harvard Medical School described his technique in 1924 (**Figure 21.5**), and the Uchida method was not reported until 1946 (**Figure 21.6**).

**The Pomeroy**



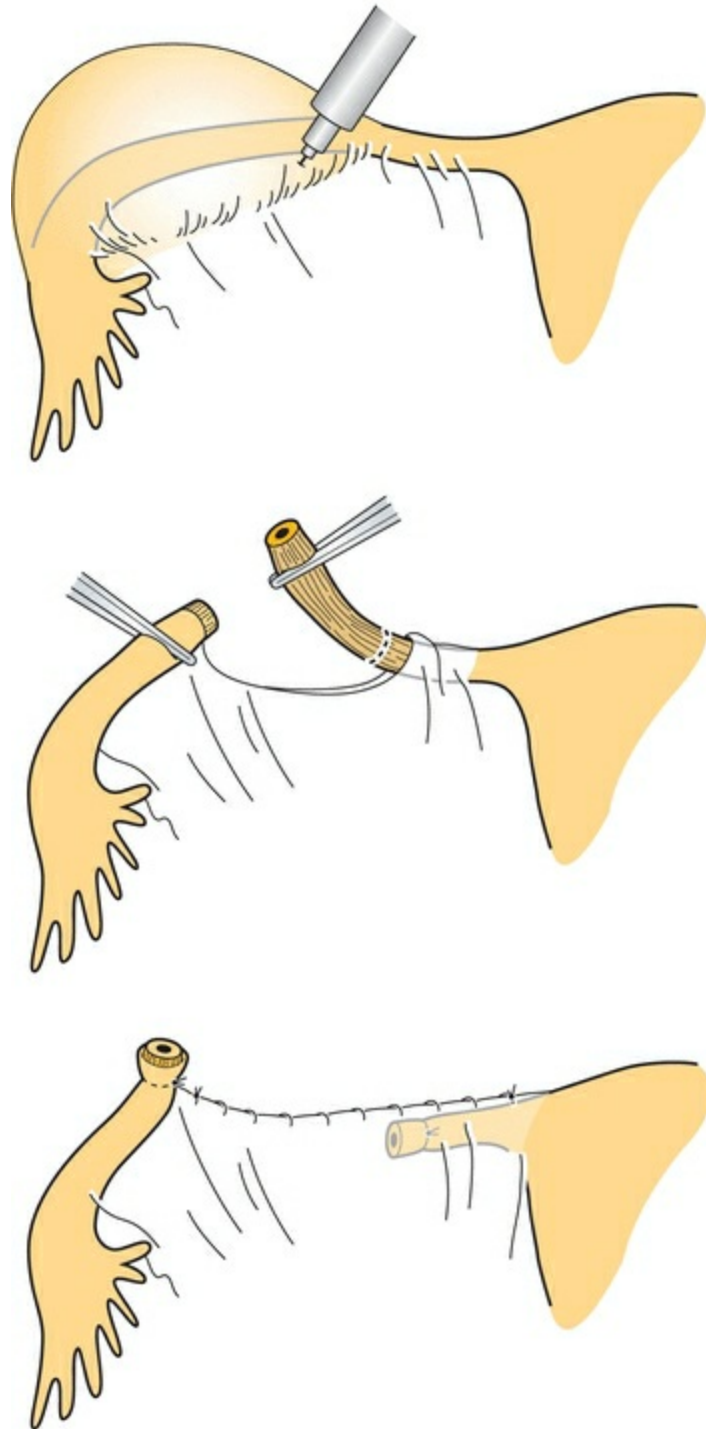
**FIGURE 21.4**

The Irving



**FIGURE 21.5**

### The Uchida



**FIGURE 21.6**

Few sterilizations were performed until the 1930s when “family planning” was first suggested as an indication for surgical sterilization by Sir Dugald Baird in Aberdeen. He required women to be older than 40 and to have had eight or more children. Mathematical formulas of this kind persisted through the 1960s. In 1965, Baird

delivered a remarkable lecture, entitled “The Fifth Freedom,” calling attention to the need to alleviate the fear of unwanted pregnancies and the important role of sterilization.<sup>48</sup> By the end of the 1960s, sterilization was a popular procedure.

Laparoscopic methods were introduced in the early 1970s. The annual number of vasectomies began to decline, and the number of tubal occlusion operations increased rapidly. By 1973, more sterilization operations were performed for women than for men. This is accurately attributed to dramatic decreases in costs, hospital time, and pain because of the introduction of laparoscopy and minilaparotomy methods. The use of laparoscopy for tubal occlusion increased from only 0.6% of sterilizations in 1970 to more than 44% by 1996.<sup>102</sup> Since 1975, minilaparotomy, a technique popular in the less developed world, has been increasingly performed in the United States, especially immediately postpartum. These methods have allowed women to undergo sterilization operations at times other than immediately after childbirth or during major surgery.

Laparoscopy and minilaparotomy have led to a profound change in the convenience and cost of sterilization operations for women. In 1970, the average woman stayed in the hospital 6.5 days for a tubal sterilization. By 1975, this had declined to 3 days, and today, women rarely remain in the hospital overnight. The shorter length of stay achieved from 1970 to 1975 represented a savings of more than \$200 million yearly in health care costs and a tremendous increase in convenience for women eager to return to work and their families.<sup>50</sup> Unlike some advances in technology, laparoscopy and minilaparotomy sterilization are technical innovations that have resulted in large savings in medical care costs.

The great majority of sterilization procedures are accomplished in hospitals by physicians in private practice, but a rapidly increasing proportion is performed outside of hospitals in ambulatory surgical settings, including physicians' offices. In either hospital or outpatient settings, female sterilization is a very safe operation. Deaths specifically attributed to sterilization accounted for a fatality rate of only 1.5 per 100,000 procedures in 1989, the most recent year for which these data are available, a mortality rate that is lower than that for childbearing (about 18 per 100,000 births in the United States).<sup>51, 52</sup> When the risk of pregnancy from contraceptive method failure is taken into account, sterilization is the safest of all contraceptive methods.

Vasectomy has long been more popular in the United States than anywhere else in the world, but why don't more men use it? One explanation is that women have chosen laparoscopic sterilization in increasing numbers. Another is that men have been frightened by reports, often from animal data, of associations with autoimmune diseases, atherosclerosis, and, most recently, prostatic cancer. Large epidemiologic studies have failed to confirm any definite adverse consequences.<sup>53</sup> When patients consider sterilization, we can assure them that vasectomy has not been demonstrated to have any

harmful effects on men's health.<sup>49</sup> In addition, vasectomy is less expensive than tubal sterilization, morbidity is less, and mortality is essentially zero.

# EFFICACY OF STERILIZATION

Laparoscopic sterilizations are not only convenient but also highly effective at preventing pregnancy. Vasectomy is also highly effective once the supply of remaining sperm in the vas deferens is exhausted. Approximately 50% of men will reach azoospermia at 8 weeks, but the time to achieve azoospermia is highly variable, reaching only about 60–80% after 12 weeks<sup>54,55</sup> (Table 21.3).

**TABLE 21.3 Failure Rates During the First Year of Use, United States<sup>15,16,17</sup>**

Age	1980	1990	2000	2005	2010	% Change 1980–2010
15–24	21 million	18.1 million	19.1 million	20.6 million	20.9 million	–0.4%
25–34	18.7	21.6	19.7	19.9	20.3	+8.6
35–44	13.1	18.9	22.7	21.8	20.6	+57.3
Total 15–44	52.8	58.6	61.5	62.3	61.8	+17

In addition to the specific operation used, the skill of the operator, age of the patient at sterilization, and time since the sterilization procedure all contribute to efficacy. Up to 50% of failures are due to technical errors. The methods using complicated equipment, such as spring-loaded clips and Silastic rings, fail for technical reasons more commonly than do simpler procedures such as the Pomeroy tubal ligation.<sup>56</sup> Interestingly, the hysteroscopic placement of tubal microinserts has a reported 0% failure rate after hysterosalpingogram has confirmed tubal blockage.<sup>57</sup> However, without confirmation of tubal occlusion, failure rates are considerably higher. Looking at patient characteristics, patients younger than 35 years were 1.5 times more likely to become pregnant.<sup>56</sup> These findings reflect the greater fecundity of younger women and the greater amount of time sterilization has to remain effective until menopause.

Significant numbers of pregnancies after tubal occlusion were in reality already present before the procedure. For this reason, some clinicians routinely perform a uterine evacuation or curettage prior to tubal occlusion.<sup>58</sup> It seems more reasonable (and cost-effective) to exclude pregnancy by careful history taking, physical examination, and an appropriate pregnancy test prior to the sterilization procedure. In addition, procedures can be timed to the follicular phase when pregnancy can be reliably avoided.

Because method, operator, and patient characteristics all influence sterilization



failures, it is difficult to predict which individual will experience a pregnancy after undergoing a tubal occlusion. Therefore, during the course of counseling, all patients should be made aware of the possibility of failure as well as the **intent** to cause permanent, irreversible sterility. It is important to avoid giving patients the impression that the tubal occlusion procedure is foolproof or guaranteed. Individual clinicians must be cautious judging their own success in accomplishing sterilization because failure is infrequent and many patients who become pregnant after sterilization never reveal the failure to the original surgeon.

Ectopic pregnancies can occur following tubal occlusion, and the incidence is much higher with some types of tubal occlusion.<sup>59</sup> Bipolar tubal coagulation is more likely to result in ectopic pregnancy than is mechanical occlusion. The probable explanation is that microscopic fistulae in the coagulated segment connecting to the peritoneal cavity permit sperm to reach the ovum. Ectopic pregnancies following tubal ligation are more likely to occur 3 or more years after sterilization, rather than immediately after. The proportion of ectopic pregnancies is 3 times as high in the 4th through the 10th years after sterilization as in the first 3 years.<sup>59</sup> For laparoscopic methods, the cumulative rate of ectopic pregnancy continues to increase for at least 10 years after surgery, reaching 17 per 1,000 for bipolar coagulation.<sup>59</sup> Overall, however, the risk of an ectopic pregnancy in sterilized women is lower than if they had not been sterilized. Nevertheless, approximately one-third of the pregnancies that occur after tubal sterilization are ectopic.<sup>59</sup>

Vaginal tubal sterilization procedures have higher failure rates than laparoscopy or minilaparotomy; however, the principal disadvantage is a higher rate of infection. Intraoperative infection is a rare complication of minilaparotomy or laparoscopic techniques, but in vaginal procedures, abscess formation approaches 1%.<sup>60</sup> This risk can be reduced by the use of prophylactic antibiotics administered intraoperatively, but laparoscopy is usually easier and safer than vaginal sterilization even in obese women.

# Sterilization and Ovarian Cancer— A Benefit of Sterilization

Serous ovarian cancer, the most common ovarian cancer, originates in the fimbriae of the fallopian tubes.<sup>61,62,63</sup> Evidence consistently indicates that tubal sterilization is associated with a major reduction in the risk of ovarian cancer.<sup>64,65,66,67,68</sup> Evidence from the Nurses' Health Study indicated that tubal sterilization was associated with a 67% reduced risk of ovarian cancer.<sup>64</sup> In the prospective mortality study conducted by the American Cancer Society, women who had undergone tubal sterilization experienced about a 30% reduction in the risk of fatal ovarian cancer.<sup>65</sup> Recently, there has been a push to perform complete salpingectomies for sterilization to potentially minimize the future risk of ovarian cancer even further. Concerns about increased surgical time, blood loss, increased risk of infection, and risk of loss of ovarian reserve have been evaluated. Studies to date have shown no increased morbidity or mortality with performing a salpingectomy at the time of cesarean section, postpartum, or in an interval manner.<sup>69,70</sup>

# FEMALE STERILIZATION TECHNIQUES

---

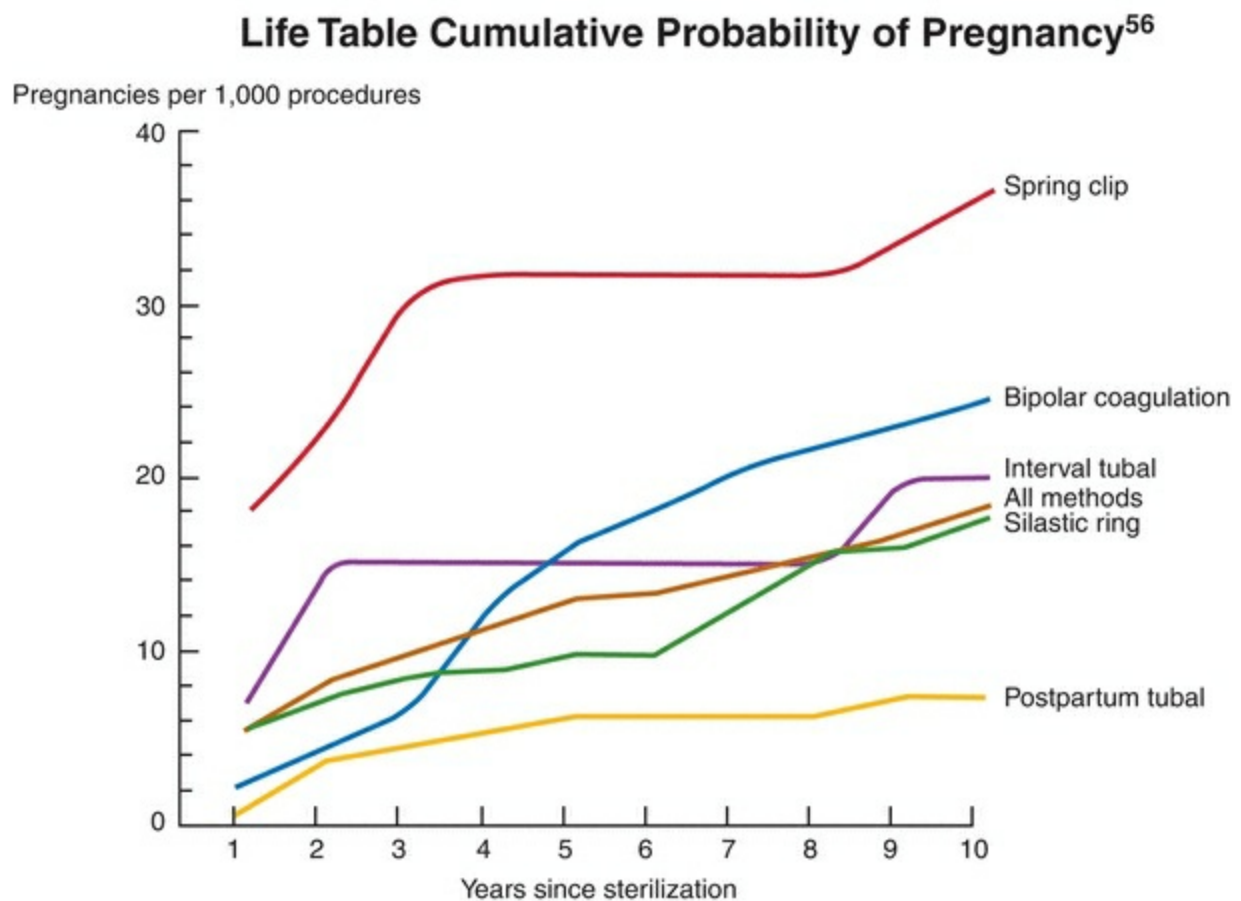
Because laparoscopy permits direct visualization and manipulation of the abdominal and pelvic organs with minimal abdominal disruption, it offers many advantages. Hospitalization is not required; most patients return home within a few hours, and the majority return to full activity within 24 hours. Discomfort is minimal, the incision scars are barely visible, and sexual activity need not be restricted. In addition, the surgeon has an opportunity to inspect the pelvic and abdominal organs for abnormalities. The disadvantages of laparoscopic sterilization include the cost, the expensive equipment, the training required, and the risks of inadvertent bowel or vessel injury.

Laparoscopic sterilization can be achieved with a variety of methods, including occlusion with unipolar or bipolar electrocautery with or without transection of the tube, partial or complete resection of the tube, and occlusion by clips or Silastic rings. Most commonly, a diagnostic laparoscope is used with operating instruments passed through a second trocar. The “open” laparoscopic technique can be used in which the camera port is placed into the abdominal cavity under direct vision to potentially avoid the risk of bowel or blood vessel puncture on blind entry. However, while the open approach results in a decreased incidence of failed entry and decreased risk of vascular injury when compared to failed attempts with the closed technique, it has not been shown to be preventative for visceral injuries (Cochrane). Patient acceptance and recovery are approximately the same with all methods.

It is now apparent that the long-term failure rates for all methods are higher than previous estimates; overall, 1.85% of sterilized American women experience a failure within 10 years.<sup>56</sup> The higher failure rates with Silastic rings and the Hulka-Clemens clip reflect the greater degree of skill required for these methods. Because of the effect of declining fecundity with increasing age, younger sterilized women are more likely to have a failure, including ectopic pregnancy, compared with older women. For these reasons, younger women seeking sterilization should consider the use of the IUD or implants, reversible methods that offer very low failure rates (Table 21.4, Figure 21.7).

## TABLE 21.4 Female Tubal Sterilization Methods 10-Year Cumulative Failure Rates<sup>56,71,72</sup>

Unipolar coagulation	0.75%
Postpartum tubal excision	0.75%
Filshie clip	0.56%
Silastic (Falope or Yoon) ring	1.77%
Interval tubal excision	2.01%
Bipolar coagulation	2.48%
Hulka-Clemens clip	3.65%



**FIGURE 21.7**

# Tubal Sterilization by Electrosurgical Methods

If electrons from an electrosurgical generator are concentrated in one location, heat within the tissue increases sharply and desiccates the tissue until resistance is so high that no more current can pass. Monopolar methods of sterilization create a dense area of current under the grasping forceps of the unipolar electrode. To complete the circuit, however, these electrons must spread through the body and be returned to the generator via a return electrode (the ground plate) that has a broad surface to minimize the density of the current to avoid burns as the electrons leave the body. “Monopolar” refers to the method that requires the patient to be grounded.

Monopolar electrosurgery can create a unique electrical “capacitance” problem. A capacitor is any device that can hold an electric charge and can exist wherever an insulated material separates two conductors that have different potentials. This property of capacitance explains some of the inadvertent bowel burns that occurred with laparoscopic sterilization.<sup>73</sup> The operating laparoscope is a hollow metal tube surrounding an active electrode, the forceps used to grasp and coagulate the tubes. When current passes through the active electrode, the laparoscope itself becomes a capacitor. Up to 70% of the current passed through the active electrode can be induced into the laparoscope. If the bowel or other structures touch a laparoscope, which is insulated from the abdominal incision (e.g., by a plastic cannula), the stored electrons will be discharged at high density directly into the vital organ. This potential hazard is eliminated by using a metal trocar sleeve rather than a nonconductive sleeve. Because there is little pressure behind the electrons from a low-voltage generator, not enough heat is generated to burn the skin as the capacitance current leaks out into the patient’s body through the metal sleeve. Even if the active electrode comes in direct contact with the laparoscope, as when a two-incision technique is used, the current will leak harmlessly through the metal trocar sleeve. The risk of inadvertent coagulation of the bowel or other organs cannot be completely eliminated because all body surfaces offer a path back to the ground plate.

The monopolar electrosurgical technique is straightforward. The isthmus portion of the fallopian tube is grasped and elevated away from the surrounding structures, and the electrical energy is applied until the tissue blanches, swells, and then collapses. The tube is then grasped, moving toward the uterus, and recoagulated, and the steps are repeated until 2–3 cm of the tube has been coagulated. Some surgeons advise against cornual coagulation for fear it may increase the risk of ectopic pregnancy due to fistula formation.

The coagulation and transection technique is performed in a similar fashion with the same instruments. In order to transect the tube, however, an instrument designed to cut tissue must be used. The transection of tissue increases the risk of possible bleeding and

does not, by itself, reduce the failure rate over coagulation alone. The specimens obtained by this method are usually coagulated beyond microscopic recognition and, therefore, will not provide pathologic evidence of successful sterilization.

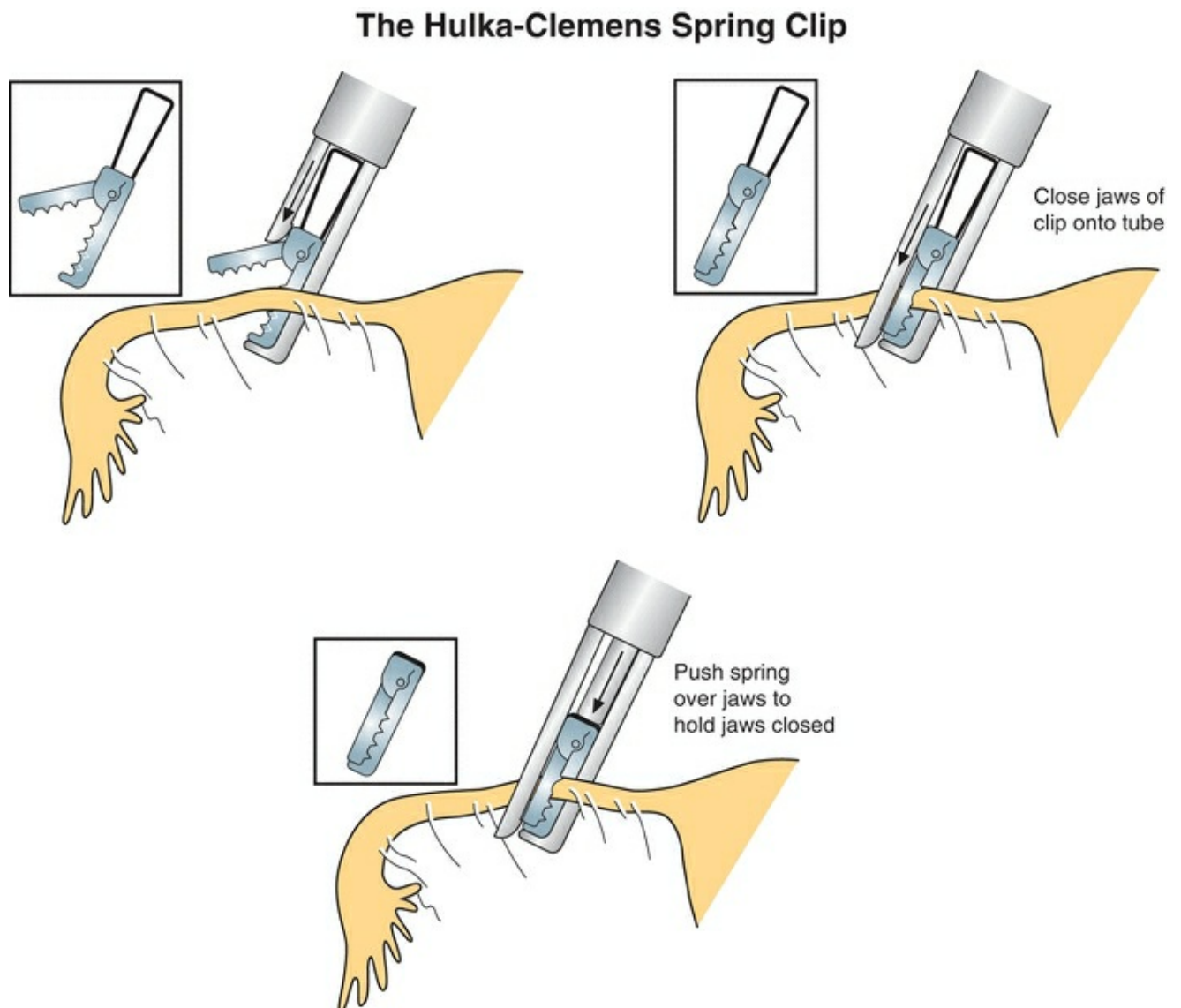
The bipolar method of sterilization eliminates the ground plate required for unipolar electrosurgery and uses a specially designed forceps. One jaw of the forceps is the active electrode, and the other jaw is the ground electrode. Current density is great at the point of forceps contact with tissue, and the use of a low-voltage, high-frequency current prevents the spread of electrons. By eliminating the return electrode, the chance of an aberrant pathway through the bowel or other structures is greatly reduced. There is, however, a disadvantage with this technique. Because electron spread is decreased, more applications of the grasping forceps are necessary to coagulate the same length of tube than with unipolar coagulation. As desiccation occurs at the point of high current density, tissue resistance increases, and the coagulated area eventually provides resistance to flow of the low-voltage current. Should the resistance increase beyond the voltage's capability to push electrons through the tissue, incomplete coagulation of the endosalpinx can result.<sup>74</sup> **Bipolar coagulation is very effective only if three or more sites are coagulated on each tube.**<sup>71</sup>

Bipolar cautery is safer than unipolar cautery with regard to burns of abdominal organs, but most studies indicate higher failure rates. Although the bipolar forceps will not burn tissues that are not actually grasped, care must be taken to avoid coagulating structures adherent to the tubes. For example, the ureter can be damaged when the tube is adherent to the pelvic sidewall.

# Tubal Occlusion with Clips and Rings

Female sterilization by mechanical occlusion eliminates the safety concerns with electrosurgery. However, mechanical devices are subject to flaws in material, defects in manufacturing, and errors in design, all of which can alter efficacy. Three mechanical devices have been widely used and have low failure rates with long-term follow-up: the Hulka-Clemens (spring) clip, the Filshie clip, and the Silastic (Falope or Yoon) ring. Each of the three requires an understanding of its mechanical function, a working knowledge of the intricate applicator necessary to apply the device, meticulous attention to maintenance of the applicators, and skillful tubal placement. These devices are less effective when used immediately postpartum on dilated tubes.

## Hulka-Clemens Spring Clip (Figure 21.8)



## FIGURE 21.8

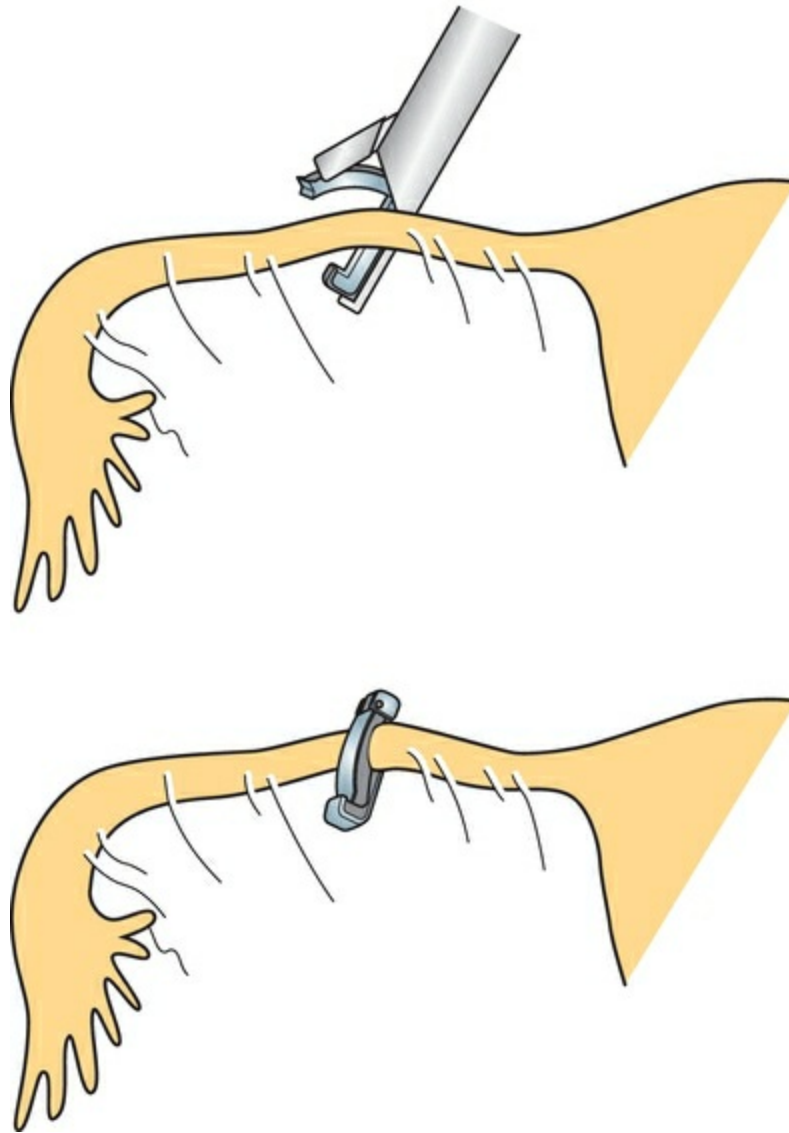
The spring clip consists of two plastic jaws made of Lexan, hinged by a small metal pin 2 mm from one end. Each jaw has teeth on the opposed surface, and a stainless steel spring is pushed over the jaws to hold them closed over the tube. A special laparoscope for one-incision application is most commonly used, although the spring clip can also be used in a two-incision procedure. The spring clip is applied at a 90-degree angle to include some mesosalpinx at the proximal isthmus of a stretched fallopian tube. The spring clip destroys 3 mm of tube and has 1-year pregnancy rates of 2 per 1,000 women but the highest 10-year cumulative failure rate.<sup>56</sup>

Complications unique to spring clip sterilization result from mechanical difficulties. If the clip is dislodged or dropped into the abdomen during the procedure, it should be retrieved. Should incomplete occlusion or incorrect alignment of the clip occur, a second clip can be applied without hazard. The clip offers a chance for reanastomosis, more so than electrosurgical methods; however, a sterilization procedure should only be undertaken if the patient understands and agrees to its permanence.

### **Filshie Clip (Figure 21.9)**



## The Filshie Clip

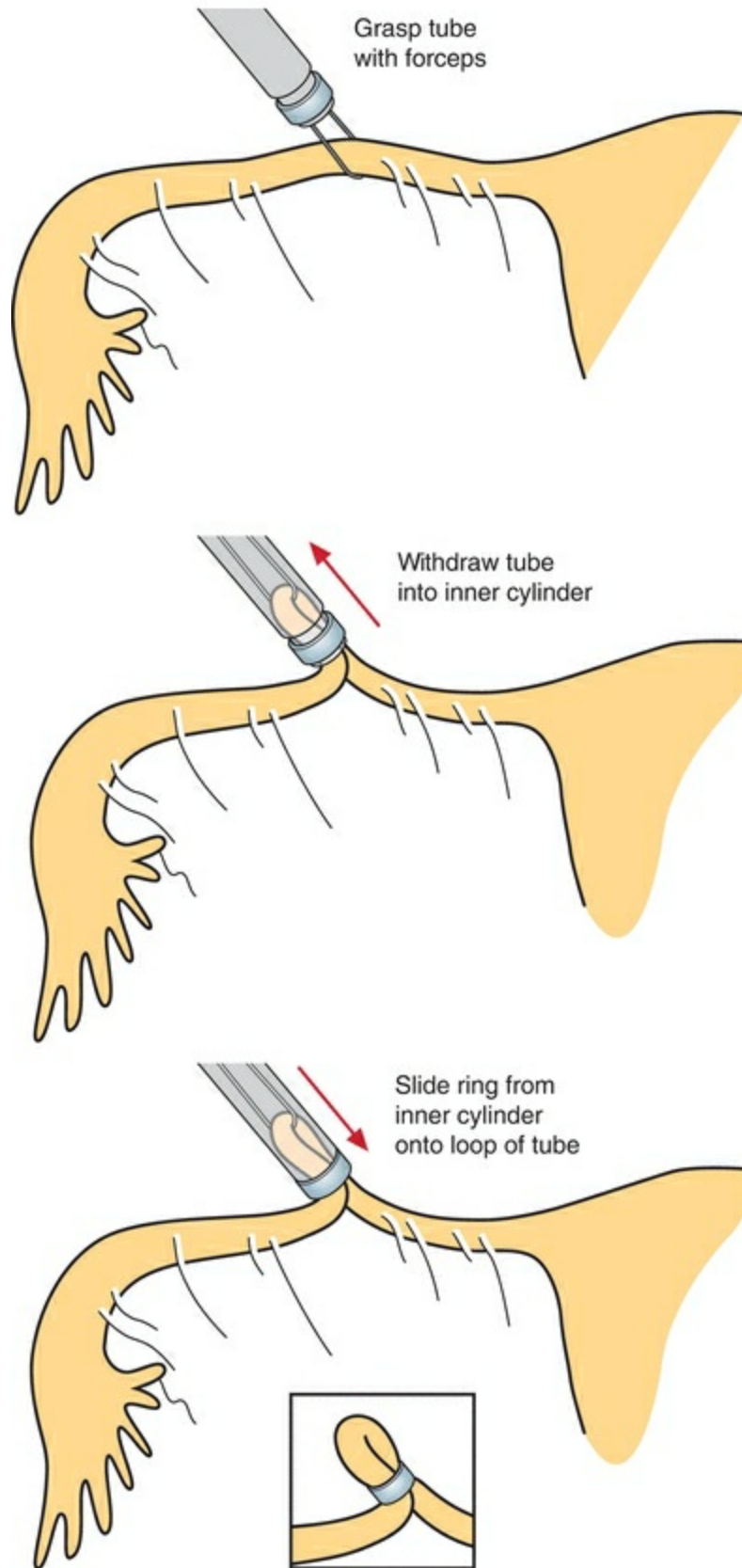


**FIGURE 21.9**

The Filshie clip is made of titanium lined with silicone rubber. The hinged clip is locked over the tube using a special applicator through a second incision or operating laparoscope. The rubber lining of the clip expands on compression to keep the tube blocked. Only 4 mm of the tube is destroyed. Failure rates 1 year after the procedure approximate 1 per 1,000 women.<sup>56</sup> A 15-year follow-up study in Quebec reported a cumulative failure rate of 9 per 1,000 women, whereas the 10-year failure rate in the United Kingdom was 5.6 per 1,000 women.<sup>72,75</sup> Because the Filshie clip is longer, it is reported to occlude dilated tubes more readily than does the spring clip. Similar to the spring clip, the Filshie clip provides a good chance for tubal reanastomosis.

## **Silastic (Falope or Yoon) Ring (Figure 21.10)**

## The Silastic (Falope-Yoon) Ring



**FIGURE 21.10**

This nonreactive Silastic rubber band has an elastic memory of 100% if stretched to no more than 6 mm for a brief time (a few minutes at most). A special applicator, 6 mm in diameter, can be placed through a second cannula or through a standard offset operating laparoscope. The applicator is designed to grasp a knuckle of tube and release the Silastic band onto a 2.5-cm loop of tube. The avascular loop of tube can be resected with biopsy forceps to provide a pathology specimen, but this is rarely performed (it does not increase efficacy). Ten to fifteen percent of patients experience severe postoperative pelvic cramping from the tight bands (which can be alleviated by the application of a local anesthetic to the tube before or after banding).

As with application of clips, the ring should be placed at the junction of the proximal and middle third of each fallopian tube. Necrosis occurs promptly and a 2–3-cm segment of the tube is destroyed. Failure rates are about 1% after 2 years, and the 10-year cumulative rate is better only with unipolar coagulation, postpartum tubal excision, and the Filshie clip.<sup>56</sup>

Mesosalpingeal bleeding is the most common complication of Silastic ring application. It usually occurs when the forceps grabs not only the tube but also a vascular fold of mesosalpinx. The mesosalpinx can also be torn on the edge of the stainless steel cylinder as the tube is drawn into the applicator. If bleeding is noted, application of the Silastic band often controls it, with reasonable next steps including placement of additional bands or use of electrocoagulation to stop the bleeding.

Silastic rings are occasionally placed on structures other than the tube. If this mistake is recognized, the band can usually be removed from the round ligament or mesosalpingeal folds by grasping the band with the tongs of the applicator and applying gradual, increasing traction. If a gentle attempt fails, removal is not necessary. If rings are inadvertently discharged into the peritoneal cavity, they can safely be left behind.

Patients should be prepared for the use of electrosurgical instruments in case bands or clips cannot be applied (because of adhesions or bleeding).

# Minilaparotomy

Tubal ligation, accomplished through a small suprapubic incision, **minilaparotomy**, is the most frequent method of interval female sterilization in the developing world. Minilaparotomy is a safe, simple, and adaptable alternative to laparoscopy that can be performed with a sedative and local anesthesia.<sup>76</sup> The fallopian tubes can be occluded through the minilaparotomy incision with bands or clips, but a simple Pomeroy tubal ligation is the method most commonly used. Patient characteristics, such as obesity, previous pelvic infection, or previous surgery, are the principal determinants of complications.<sup>77</sup>

Minilaparotomy is accomplished through an incision that usually measures 2–4 cm in length. Tubal ligation through a suprapubic incision can be accomplished for obese patients, but the incision will necessarily exceed the usual length. Forceful retraction increases the pain associated with the procedure and the time of recovery. For these reasons, we believe that minilaparotomy for ambulatory tubal occlusion should be limited to patients who are not obese (usually <150–160 lb, 70 kg). Postpartum tubal ligation following vaginal delivery can also be performed in a similar fashion, though the small incision is placed infraumbilically due to the increased size of the recently gravid uterus.

Tubal occlusion is difficult to accomplish through a minilaparotomy if the uterus is immobile. Laparoscopic tubal occlusion, on the other hand, does not require extreme uterine elevation or rotation and is a better choice for a patient with a uterus fixed in position.

# The Transcervical Approach

Although current methods of sterilization are safe and effective, they require skillful surgeons and, in the case of laparoscopic operations, elaborate and expensive equipment. Simpler approaches could make sterilization available and acceptable to more women. Transcervical methods have used electrocoagulation, cryosurgery, or laser to destroy the interstitial portion of the tube, to inject sclerosing agents or tissue adhesives (Femcept) through the tubal ostia, and to mechanically obstruct the tubal lumen. Most of these methods and the formed-in-place silicone plugs applied hysteroscopically are either too complicated or have high failure rates. The most practical approach is the application of sclerosing agents to the tubal openings using cannulae or an IUD. Transcervical insertion of quinacrine pellets during the proliferative phase of the menstrual cycle occludes the tubes and is the most promising of the “nonsurgical” approaches, with a 1.2% 10-year failure rate after two treatments. Some concern about quinacrine being related to reproductive tract cancers decreased its popularity, but these concerns have been dispelled after over 20 years of follow-up of women who had received this treatment.<sup>78</sup>

**Essure** is a metal coil device with polyester fibers (polyethylene terephthalate), which when placed hysteroscopically within the proximal segment of the fallopian tube spanning the uterotubal junction expands when released, anchoring itself in place. The polyester fibers in the device stimulate a tissue reaction, which is fibrotic and occlusive. After backup contraception for 3 months, a hysterosalpingogram is performed to confirm occlusion. If occlusion is not present at 3 months, contraception is continued and hysterosalpingography is repeated 3 months later. The procedure is quick, performed in the outpatient setting, often without analgesia, and considerably less expensive than laparoscopy. Effective permanent sterilization was initially achieved in about 85–90% of women.<sup>79</sup> With greater experience, placement can reach a 96% rate.<sup>80,81</sup> The risk of pregnancy after 5 years was 2.6 per 1,000 women, with no ectopic pregnancies.<sup>82</sup> Essure will be voluntarily taken off the US market as of December 31, 2018, due to declining sales. **Adiana** is a two-step procedure that has also been discontinued by the manufacturer for financial concerns, but was similar to Essure in that a hysteroscopic placement of a device was performed, followed by hysterosalpingogram 3 months later to confirm permanent blockage. Successful placement is achieved in 92–95% of women, with a 1-year pregnancy rate of 1.1%.<sup>79,83</sup>

# The Vaginal Approach

Although vaginal techniques are still used for tubal sterilization, high rates of infection and occasional pelvic abscesses following these operations have caused most clinicians to abandon them.<sup>60</sup> An apparent advantage in obese patients is sometimes deceptive because omental fat can block access to the fallopian tubes. Open laparoscopy is usually easier and safer in obese women.

# COUNSELING FOR STERILIZATION

---

All patients undergoing a surgical procedure for permanent contraception should be aware of the nature of the operation, its alternatives, efficacy, safety, and complications. The operation can be described using drawings or pelvic models, slides, or recordings. The description of the operation should emphasize its similarities to and differences from laparoscopy and pelvic surgery, especially hysterectomy or oophorectomy that may be confused with simple tubal ligation. Women who undergo tubal sterilization by any method are four- to fivefold more likely to have a hysterectomy; no biologic explanation is apparent, and this may reflect patient attitudes toward surgical procedures.<sup>84</sup> Alternatives, including vasectomy, steroid contraception, long-acting hormone methods, barrier methods, and IUDs, should be reviewed. It is important to emphasize to the patient that tubal ligation is not intended to be reversible, that it cannot be guaranteed to prevent intrauterine or ectopic pregnancy, and that failures can occur long after the sterilization procedure. Informed consent is best obtained at a time when a patient is not distracted or distraught, for example, not immediately before or after an induced abortion.



# Sexuality

There is no detrimental effect on sexuality specifically due to sterilization procedures.<sup>85,86</sup> Indeed, sexual life is usually positively affected. Many couples are less inhibited and more spontaneous in their sexual encounters when they do not have to worry about an unwanted pregnancy.

# Menstrual Function

There was some concern that tubal sterilization was associated with higher rates of dysmenorrhea and changes in menstrual function.<sup>87,88</sup> As noted above, hysterectomy rates are higher for women who have had a tubal sterilization. It was initially speculated that extensive electrocoagulation of the fallopian tubes can cause ovarian tissue damage, changing ovarian steroid production. This was suggested as the reason why menstrual changes were detected with longer (4 years) follow-up, whereas no changes had been noted with the use of rings or clips.<sup>89,90,91</sup> However, attempts to relate poststerilization menstrual changes with extent of tissue destruction failed to find a correlation, and an increase in hospitalization for menstrual disorders after monopolar cautery could not be documented.<sup>89,91</sup> A long-term follow-up study (3–4.5 years) failed to document any significant changes in menstrual cycles.<sup>92</sup> Follow-up studies at 3 months, 6 months, 2 years, and 5 years after sterilization by bipolar coagulation or Hulka clip could detect no changes in day 3 measures of ovarian reserve (gonadotropins, estradiol, and inhibin) or luteal phase levels of estradiol and progesterone.<sup>93,94,95,96</sup> In patients who have had tubal sterilization procedures, hysterectomies for pelvic pain or for abnormal uterine bleeding have been shown to be most common in women who had those symptoms prior to their sterilization procedures.<sup>97</sup> In the United States, a prospective, long-term follow-up study of sterilization showed that the increased risk of hysterectomy after sterilization was concentrated in women who were treated for gynecologic disorders before tubal sterilization.<sup>84</sup>

**The U.S. Collaborative Review of Sterilization, the largest and most comprehensive assessment of sterilization, could find no evidence that tubal sterilization is followed at 2 years and again at 5 years by a greater incidence of menstrual changes or abnormalities.<sup>98</sup> The evidence indicates that tubal sterilization does not cause menstrual abnormalities.**

# Reversibility

An important objective of counseling is to help couples make the right decision about an irreversible decision to become sterile. The active participation of both partners is a critical factor.<sup>99</sup> Not all couples are pleased following sterilization; in one series, 2% of US women expressed regret 1 year later and 2.7% after 2 years.<sup>100</sup> At the 2-year mark, the main factors associated with regret were age less than 30 and sterilization at the convenient time of a cesarean section. In another long-term follow-up study of US women, women younger than the age of 30 at the time of sterilization were most likely to express regret, but no differences were observed comparing timing after cesarean delivery, vaginal delivery, or a year later.<sup>101</sup> In the 1995 National Survey of Family Growth, nearly 25% of US women with a tubal ligation expressed a desire for reversal, by either one of the partners or both.<sup>42</sup> The U.S. Collaborative Review of Sterilization reported that only 14.3% requested reversal information after 14 years of follow-up, but the percentage was nearly 4 times higher in women aged 18–24 at sterilization.<sup>103</sup> Other studies have shown that women obtaining tubal sterilization before age 30 are up to 18 times as likely to request information on tubal reversal or assisted reproductive therapy and up to 8 times as likely to actually undergo tubal reversal or in vitro fertilization than women who undergo the sterilization procedure after age 30.<sup>104</sup> Overall, however, only 1.1% of women obtained reversal. In Canada, 1% of men and women obtained a reversal within 5 years after sterilization; in the United States, reversal within 5 years was obtained by 0.2% of women and 0.4% of men, a difference that could reflect the lack of insurance coverage for this procedure in the United States.<sup>75,105</sup> In addition to young age at the time of sterilization, an important risk factor for regret was an unstable marriage.<sup>106</sup> A change in marital status is undoubtedly an important reason for a desire to reverse sterilization.<sup>107</sup> Young couples in unstable relationships need special attention in counseling. Furthermore, for many couples, tubal occlusion at the time of emergency cesarean section or immediately after a difficult labor and delivery is not the best time for the procedure. It is important to know that sterilized women have not been observed to develop psychological problems at a greater than expected rate.<sup>108,109</sup>

Microsurgery for tubal anastomosis is associated with excellent results if only a small segment of the tube has been damaged. Pregnancy rates correlate with the length of the remaining tube—a length of 4 cm or more is optimal—and age at reversal procedure. Pregnancy rates can approach 88% in women less than 30 who had a clip or ring procedure initially and are as low as 36% in women over 40 who had electrocoagulation initially.<sup>110</sup> About 2 per 1,000 sterilized women will eventually undergo tubal anastomosis.<sup>107</sup>

# MALE STERILIZATION: VASECTOMY

---

Vasectomy is safer, easier, and less expensive and has a lower failure rate than female sterilization.<sup>111</sup> The operation is almost always performed under local anesthesia, usually by a urologist in a private office.<sup>112</sup> Surgeons who do more than 10 operations yearly have lower complication rates.<sup>113</sup>

Hematomas and infection occur rarely and are easily treated with heat, scrotal support, and antibiotics. Most men will develop sperm antibodies following vasectomy, but no long-term sequelae have been observed, including no increased risk of immune-related diseases or cardiovascular disease.<sup>49,114,115</sup> Adverse psychological and sexual effects have not been reported.<sup>116</sup> Because the other constituents of semen are made downstream from the testes, men do not notice a decreased volume or velocity of ejaculate.

Prostate cancer is the most frequent cancer among men, with a lifetime risk of one in eight in the United States. An increased risk of prostate cancer after vasectomy was reported in several cohort and case-control studies.<sup>117,118,119,120</sup> However, there was disagreement because other studies could not support an association between prostate or testicular cancer risk and vasectomy.<sup>114,121,122,123,124,125,126</sup> In a very large mixed racial/ethnic (Black and White, Chinese Americans and Japanese Americans) case-control study of prostate cancer, no statistically significant increase in risk could be identified after vasectomy, including no effect of age at vasectomy or years since vasectomy.<sup>127</sup> Reviews of six cohort studies and five case-control studies concluded that there is no increased risk of cancer of the testis following vasectomy, and consideration of the studies examining the possible association between prostate cancer and vasectomy (six cohort and seven case-control studies) found the evidence to be equivocal and weak.<sup>128,129</sup> A meta-analysis of the literature concluded that there is no increased risk of prostate cancer in men who have undergone vasectomy.<sup>130</sup> A case-control study from New Zealand found no increase in prostate cancer even after more than 25 years since the vasectomy.<sup>131</sup> Observational studies cannot totally avoid potential biases, and the disagreement regarding prostate cancer is consistent with either no effect or an effect too small to escape confounding biases. It is worth noting that the countries with the highest vasectomy rates (China and India) do not have the highest rates of prostate cancer. Screening for prostate cancer should be no different in men who have had a vasectomy.

Animal studies had indicated that vasectomy accelerates the process of atherosclerosis. In the U.S. Physicians' Health Study (a large prospective cohort study), no increase in the risk of subsequent cardiovascular disease could be detected

following vasectomy.<sup>132</sup> Indeed, vasectomy has not been demonstrated to have any adverse consequences or harmful effects on men's health.<sup>49</sup>

Vasectomy does not change the secretion of HIV into semen, and vasectomy should not change the risk of HIV transmission.<sup>133</sup>

Vasectomy reversal is associated with pregnancy rates as high as 70–80%.<sup>134</sup> The prospect for pregnancy diminishes with time elapsed from vasectomy, decreasing significantly to 30% after 10 years; the best results are achieved when reversal is performed within 3 years after vasectomy.<sup>135</sup> In most cases, sperm can be collected at the time of the reversal procedure and frozen for potential future intracytoplasmic sperm injection in case the reversal is unsuccessful.

# MEDICAL METHODS FOR THE MALE

---

A reversible method of contraception for men has been sought for years. Hormonal contraception for men is inherently a difficult physiologic problem because, unlike cyclic ovulation in women, spermatogenesis is continuous and high numbers of sperm are produced.<sup>136</sup> Investigational approaches to inhibit production of sperm include the administration of sex steroids, the use of GnRH analogs, and the administration of gossypol, a derivative of cottonseed oil.<sup>137,138</sup>

The use of exogenous sex steroids reduces testosterone synthesis, which leads to loss of libido and development of female secondary sexual characteristics. Furthermore, despite the use of large doses, sperm counts are not adequately reduced in all subjects. Levonorgestrel, cyproterone acetate, and medroxyprogesterone acetate all have been studied combined with testosterone, given intramuscularly to provide the desired systemic androgen effects. GnRH analogs also decrease the endogenous synthesis of testosterone, and supplemental testosterone must be provided. The overall metabolic and health consequences of these approaches have not been assessed, and frequent injections are required. No methods are ready for clinical use.<sup>139</sup>

Gossypol effectively decreases sperm counts to contraceptive levels, apparently by incapacitating the sperm-producing cells. Experience in China revealed that a substantial number of men remain sterile after exposure to gossypol, and animal studies in the United States indicated that gossypol, or contaminants of the preparation, was toxic; thus, work on gossypol was discontinued.<sup>140</sup> Analogs of gossypol may offer potential, but are years away from development.

# INDUCED ABORTION

---

Contraception is more effective and convenient than ever, but even the most conscientious couples can experience contraceptive failure. In the past, failure of contraception meant another, sometimes unwanted, birth or recourse to dangerous, secret abortion. The most ancient medical texts indicate that abortion has been practiced for thousands of years. Induced abortion did not become illegal until the 19th century, as a result of changes in the teachings of the Catholic Church (life begins at fertilization), and in the United States, the efforts of the American Medical Association to have greater regulation of the practice of medicine.

In the 1950s, vacuum aspiration led to much safer abortion, and beginning in Asia, induced abortion was gradually legalized in the developed countries of the world. This trend reached the United States from Western Europe in the late 1960s when California, New York, and other states rewrote their abortion laws. The U.S. Supreme Court followed the lead of these states in 1973 in the “Roe versus Wade” decision that limited the circumstances under which “the right of privacy” could be restricted by local abortion laws. By 1980, legal abortion became the most common surgical procedure performed in the United States. The average cost of a nonhospital abortion with local anesthesia in 2012 was \$480.<sup>142</sup>

The number of abortions performed in the United States has been decreasing since a peak of 1.6 million was reached in 1981, declining to 962,000 in 2014, with the greatest decrease among teenagers.<sup>3</sup> This is partly because the number of pregnancies in the United States has been decreasing and the proportion of reproductive-aged women younger than age 30 is also decreasing.<sup>52</sup> However, better use of effective contraception made a major contribution to the decline in the abortion rate. In 2011 and 2012, 61% of induced abortions were obtained by women in their 20s and 12% by women younger than 20.<sup>142</sup>

Overall, 2.8 million (45%) of American pregnancies each year are unintended, but the percentage is only 38% among White women in contrast to 50% among Hispanics and 64% among Blacks.<sup>3</sup> Each year, 42% of unintended pregnancies are terminated by induced abortions. The rate of unintended pregnancies and abortions is about 4 times higher among poor women.

Worldwide, about 20% of all pregnancies end in induced abortion.<sup>1</sup> The number of induced abortions has declined in developed countries to less than 7 million annually. Most induced abortions occur in developing countries, about 35 million annually, where more than half are unsafe, illegal abortions. It is also worth emphasizing that in countries where there are legal restrictions on abortion, the abortion rates are not lower

compared with areas where abortion is legally permitted; however, these illegal abortions are associated with infection and hemorrhage, accounting for 13% of maternal deaths worldwide.<sup>143</sup> **Abortion restrictions do not reduce the rate of abortions, but do make the procedure less safe.**



# Safety of Induced Abortions

Public health authorities have demonstrated that the legalization of abortion reduced maternal morbidity and mortality more than any single development since the advent of antibiotics to treat puerperal infections and blood banking to treat hemorrhage. The number of American women reported as dying from abortion declined from nearly 300 deaths in 1961 to 4 in 2013, or about **0.6 deaths for every 100,000 legal abortions**.<sup>144</sup> For comparison, in 2011–2013, the maternal death rate for childbirth in the United States was 17 per 100,000 births.<sup>145</sup>

The most important determinants of abortion mortality are duration of gestation and type of anesthesia: later abortions and general anesthesia are more hazardous.<sup>146,147,148</sup> As with mortality, morbidity rates vary primarily with duration of pregnancy, but other factors are important as well, including the type of operation, age of patient, type of anesthesia, operator's skill, and method of cervical dilation. More experienced surgeons and younger, healthier women are less likely to have complications.

Major and minor complications in a series of 170,000 first-trimester abortion patients were as follows<sup>149</sup> (Table 21.5).

## TABLE 21.5

## Major Complications (Hospitalization Required)

Retained tissue	27.7 per 100,000 induced abortions
Sepsis	21.2
Uterine perforation	9.4
Hemorrhage	7.1
Inability to complete	3.5
Intrauterine plus tubal pregnancy	2.4

## Minor Complications (Managed in Clinic or Office)

Mild infection	462.0 per 100,000 induced abortions
Reaspiration same day	180.8
Reaspiration later	167.8
Cervical stenosis	16.5
Cervical tear	10.6
Underestimated gestation	6.5
Convulsive seizure	4.0

The possibility that abortion can result in longer-term complications has been examined

in more than 150 studies.<sup>150</sup> There is no evidence for any adverse consequences of vacuum aspiration abortion for subsequent fertility<sup>150,151</sup> or increased risk for ectopic pregnancy.<sup>141,152,153</sup> Second-trimester abortions do not increase the rate of preterm delivery or midtrimester fetal losses, nor do they seem to have an impact on future fertility.<sup>154,155</sup> Multiple induced abortions do not increase the risk of a subsequent ectopic pregnancy.<sup>156</sup> Recent meta-analyses show that induced surgical abortion may be associated with a slightly increased risk of preterm birth in subsequent pregnancies.<sup>156,157,158</sup> The long-term effects of second-trimester abortion may depend on the method used.<sup>159</sup> A French study disagrees with these conclusions, finding a slightly increased risk of ectopic pregnancy in women with a prior induced abortion and no previous ectopic pregnancy, and Chinese and Danish studies found a small increase in the risk of spontaneous miscarriage following surgically induced abortions.<sup>161,162,163</sup>

The psychological sequelae of elective abortion have been studied and debated. The evidence indicates that depression is less frequent among women postabortion compared with postpartum, that women denied abortion experience resentment for years, and that the children born after an unwanted pregnancy have social, occupational, and interpersonal difficulties lasting into early adulthood.<sup>164</sup> Extensive reviews of the evidence, including one by the American Psychological Association, concluded that first-trimester induced abortions do not increase the risk for mental health problems.<sup>165,166</sup> Adverse psychological responses following induced abortion are influenced by a need for secrecy, perceptions of associated stigma, inadequate social support, and troubling personality characteristics such as low self-esteem or improper coping strategies, but the most important predictor of a negative mental reaction is a prior history of mental problems.<sup>166</sup>

Conflicting results were reported in over 20 studies examining the risk of breast cancer associated with the number of abortions (especially induced abortions) experienced by individual patients.<sup>167,168</sup> Concern for an adverse effect has been based on the theoretical suggestion that a full-term pregnancy protects against breast cancer by invoking complete differentiation of breast cells, but abortion increases the risk by allowing breast cell proliferation in the first trimester of pregnancy but not allowing the full differentiation that occurs in later pregnancy. In these studies, there was a major problem of recall bias; women who develop breast cancer are more likely to truthfully reveal their history of induced abortion than healthy women. **In studies that avoided recall bias (e.g., by deriving data from national registries instead of personal interviews), the risk of breast cancer was identical in women with and without induced abortions.**<sup>169,170</sup> More careful case-control and cohort studies, including the Nurses' Health Study, also failed to link a risk of breast cancer with induced or

**spontaneous abortions.** <sup>171,172,173,174</sup>

Safe abortion is still unavailable to many women. It is estimated that between 2010 and 2014, 25.1 million unsafe abortions were performed, 97% of these being in developing countries.<sup>175</sup> The fatality rate for unsafe abortions is up to 350 deaths for 100,000 abortions. These deaths are preventable. Family planning services that provide effective contraceptive choices as well as access to safe abortion early in pregnancy are essential in order for societies to achieve desired fertility rates and a healthy female population.

# Pretreatment Care of Abortion Patients

Approximately 90% of the 962,000 induced abortions performed in the United States yearly are performed during the first trimester of pregnancy, and a growing percentage is accounted for by medical abortion.<sup>3,176</sup> The vast majority (94%) of these procedures occur in freestanding abortion clinics.<sup>177</sup> The safety of outpatient abortion surgery under local anesthesia is well established.

The care of the patient who has decided to terminate a pregnancy begins with the diagnosis of intrauterine pregnancy and an accurate estimate of gestational age. Failure to accomplish this is the most common source of abortion complications and subsequent litigation. Vaginal ultrasound should be used when accurate dating is otherwise difficult or unsure.

Nearly all women who want to terminate a pregnancy in the first trimester are good candidates for an outpatient surgical procedure under local anesthesia. Possible exceptions include patients with severe cardiorespiratory disease, severe anemias or coagulopathies, mental disorders severe enough to preclude cooperation, and excessive concern about operative pain that is not alleviated by reassurance.

Surgical abortions should not be undertaken for women who have known uterine anomalies or leiomyomas or who have previously had difficult first-trimester abortion procedures, unless ultrasonography is immediately available and the surgeon is experienced in its intraoperative use. Previous cesarean section or other pelvic surgery is not a contraindication to outpatient first-trimester surgical abortion.

# Counseling Abortion Patients

Counseling has played a critical role in the development of efficient and acceptable abortion services and to ensure quality patient care. Counseling responsibilities include helping with decision-making; providing information about the procedure; obtaining informed consent; providing emotional support for the patient and her family before, during, and after the procedure; and providing information about contraception.<sup>178</sup> Referral opportunities should be provided for prenatal care and adoption for women who choose to carry an unplanned pregnancy to term. These responsibilities can be performed by a physician, nurse, psychologist, social worker, or a trained layperson. An informed consent document should unequivocally state the possibilities of common adverse outcomes, such as incomplete abortion, infection, uterine perforation, the need for laparotomy, ectopic pregnancy, and failed abortion. The counselor should document this discussion.

Nearly half of induced abortions in the United States are repeat abortions.<sup>179</sup> Repeat elective abortions are more common in older women, in women using a method of contraception, and in women reporting alcohol or drug abuse. Counseling after elective abortions should emphasize effective, long-term methods of contraception such as the IUD, implants, or sterilization.

# Methods for First-Trimester Abortions

The most widely used technique for first-trimester abortions is vacuum curettage.<sup>142,176</sup> The procedure is performed using local anesthesia (a paracervical block). Cervical dilation is accomplished with tapered Pratt dilators. Some surgeons recommend the preoperative insertion of cervical tents. These are osmotic dilators of dried seaweed or synthetic hydrophilic substances that are left in place from a few hours (synthetic) to overnight (seaweed).<sup>182</sup> Mifepristone (RU-486), the progesterone antagonist, produces preoperative cervical dilation equally effectively, and the ease of its single oral dose makes it a more attractive choice, but oral mifepristone requires a long pretreatment (24–36 hours).<sup>181</sup> Buccal misoprostol (400 µg) dilates the cervix as effectively as laminaria when given 4 hours prior to the procedure, and it is relatively inexpensive.<sup>182</sup> After the procedure, the patient is observed for 1–2 hours before returning home.

Aspiration surgical abortion is safe and effective, but it is not available everywhere, and some women find it difficult to undergo a surgical procedure or to go to a clinic where they may be subject to loss of privacy or harassment. Nonsurgical methods make abortion available to more women and improve the circumstances under which pregnancies are terminated. The progesterone antagonist mifepristone (RU-486) and the antimetabolite methotrexate have both been demonstrated to effectively induce abortion early in pregnancy when combined with a prostaglandin.<sup>186,187</sup> Medical first-trimester abortions do not increase risks in future pregnancies, including ectopic pregnancy, spontaneous miscarriage, preterm birth, or low birth weight.<sup>183</sup> Although both medical and surgical abortion methods have a very low rate of serious complications, medical abortion is associated with more discomfort, bleeding, and incomplete abortion.<sup>180,184,185</sup>

France and China were the first countries to approve the marketing of the medical abortifacient mifepristone, a synthetic relative of the progestational agents in oral contraceptives. Mifepristone acts primarily, but not totally, as an antiprogestational agent. Both progesterone and mifepristone form hormone-receptor complexes that are similar, but the mifepristone complex has a slightly different conformational change (in the hormone-binding domain) that prevents full gene activation. The agonistic activity of this progestin antagonist is due to its ability to activate certain, but not all, of the transcription activation functions on the progesterone receptor. The dimethyl (dimethylaminophenyl) side chain at carbon 11 of mifepristone is the principal factor in its antiprogestone action. There are three major characteristics of its action that are important: a long half-life, high affinity for the progesterone receptor, and active metabolites.

A single oral dose of mifepristone may be followed a day later by the

administration of a prostaglandin analog. Several analogs have been used, but the most widely available and best tolerated was misoprostol, 800 µg administered vaginally.<sup>186</sup> When administered in the first 8 weeks of pregnancy, this medical termination carried success and complication rates similar to those achieved with vacuum curettage.<sup>187,188</sup>

Misoprostol is a stable, orally active synthetic analog of prostaglandin E<sub>1</sub>, available commercially for the treatment of peptic ulcer. Combined with mifepristone, it provides an effective, simple, inexpensive method that can be administered at home.<sup>188,189,190,191,192</sup> In the large US trial of 600 mg mifepristone followed by 400 µg misoprostol orally, there was a 1% failure rate under 7 weeks of pregnancy and 9% from 8 to 9 weeks.<sup>193</sup> Termination occurred in 50% of the women within 4 hours after misoprostol administration and 75% within 24 hours.

Based on worldwide experience, the regimen with the least side effects and cost, but equally good efficacy, was a combination of a lower dose of oral mifepristone (200 mg), followed 48 hours later by the vaginal administration of 800 µg misoprostol at home.<sup>188,191,194,195,196</sup> The vaginal administration of misoprostol allowed medical abortion up to 63 days after the last menstrual period.<sup>189</sup> However, because of a problem with infection, the protocol for medical abortion changed.

In 2005, the Centers for Disease Control and Prevention reported four cases of fatal toxic shock syndrome in California associated with *Clostridium sordellii* that occurred within 1 week after medical abortions (induced with 200 mg of oral mifepristone and 800 µg of vaginal misoprostol).<sup>197</sup> This prompted many clinicians and the Planned Parenthood Federation to switch to buccal administration of misoprostol, recognizing that *Clostridium* species are present in a small percentage of vaginal cultures.

Beginning in 2006, Planned Parenthood Federation clinics changed to a protocol that administered 800-µg misoprostol buccally 24–48 hours after 200 mg mifepristone and either to screen with vaginal cultures, especially for STIs, and treat appropriately or to provide prophylactically doxycycline 100 mg b.i.d. for 7 days beginning on the day of mifepristone. In 2008, the protocol was again changed, requiring prophylactic doxycycline treatment. The routine use of antibiotics was associated with a greater reduction in serious infection compared with the method of screen and treat. Following these changes, the number of serious infections decreased from 93 to 6 cases in 100,000 medical abortions, a decline of 93%.<sup>198</sup> **The buccal misoprostol protocol is 98% effective at up to 49 days' gestation and provides comparable efficacy to vaginal misoprostol up to 63 days' gestation, an expected outcome because the pharmacokinetics of misoprostol are essentially the same with either buccal or vaginal administration.**<sup>199,200,201</sup> **The buccal route of administration of misoprostol is now the recommended method.**



Infection with *Clostridium* species has been associated with spontaneous miscarriages, the postpartum period, after trauma or surgical procedures, and even when buccal misoprostol was used.<sup>202</sup> The best prevention of fatal toxic shock with this rare infection is awareness of the possibility and early recognition. Abdominal cramping as a presenting complaint makes the diagnosis difficult because this is a common symptom following medical abortion. Unique characteristics include the absence of fever, markedly elevated white counts, fluid effusions sufficient to produce hemoconcentration, and eventually tachycardia and hypotension. Specific antibiotics with demonstrated efficacy against *Clostridium sordellii* have not been identified, although doxycycline inhibits *Clostridium* growth in vitro. Early recognition of this rare infection would mandate consideration of aggressive surgery with hysterectomy, a lesson learned from the experience with septic abortions in the years before legalized abortion.

It is likely that abortion with mifepristone is the result of multiple actions. Although mifepristone does not induce labor, it does open and soften the cervix (this may be an action secondary to endogenous prostaglandins). Its major action is its blockade of progesterone receptors in the endometrium. This leads to a disruption of the embryo and the production of prostaglandins. The disruption of the embryo and perhaps a direct action on the trophoblast lead to a decrease in human chorionic gonadotropin (hCG) and a withdrawal of support from the corpus luteum. The success rate is dependent on the length of pregnancy—the more dependent the pregnancy is on progesterone from the corpus luteum, the more likely that the progesterone antagonist, mifepristone, will result in abortion. The combined mifepristone-prostaglandin analog method is usually restricted to pregnancies that are not beyond 9 weeks' gestation. However, a regimen using a higher dose of misoprostol (administered vaginally) achieved a 95% complete abortion rate in women at 9–13 weeks' gestation.<sup>203</sup> Other progesterone antagonists have been developed, but only mifepristone has undergone extensive abortion trials.

Mifepristone is most noted for its abortifacient activity and the political controversy surrounding it. However, the combination of its agonistic and antagonistic actions can be exploited for many uses, including contraception, therapy of endometriosis and fibroids, induction of labor, treatment of Cushing syndrome, and, potentially, treatment of various hormone-dependent cancers. Doses of 2–5 mg/day inhibit ovulation and produce amenorrhea in over 90% of cycles, and in a pilot study of 50 women, there were no pregnancies.<sup>204</sup> A clinical trial indicated that a daily dose of 5 mg mifepristone would be an effective oral contraceptive.<sup>205</sup>

Methotrexate was tested as an abortifacient in the same dose used to treat ectopic pregnancy, 50 mg intramuscularly per square meter of body surface area.<sup>206</sup> Later, a single 75-mg intramuscular dose was demonstrated to be as effective.<sup>207</sup> Methotrexate

has also been administered orally in doses of 25 or 50 mg.<sup>208</sup> As with mifepristone, a prostaglandin is added to promote expulsion of the uterine contents. The first trials demonstrated that if the prostaglandin (800 µg misoprostol vaginally) was given a week after the injection of methotrexate, this method could be almost as, **but not as**, effective as mifepristone.<sup>209</sup> Efficacy diminishes with advancing gestation beyond 7 weeks since the last menstrual period.<sup>210,211,212</sup> Because methotrexate takes longer to act than mifepristone, the prostaglandin is used a week after the initial treatment and is repeated a day later if expulsion has not occurred. Methotrexate is easily available and inexpensive. It has been used in low doses to treat psoriasis and rheumatoid arthritis, as well as ectopic pregnancy, without adverse effects. It is, however, a known teratogen that can be deadly in high doses, and its use as an abortifacient results in prolonged bleeding and a prolonged time to abortion (up to a month in some cases). Mifepristone is preferred by clinicians who have experience with both methods, but there are no direct comparison studies of methotrexate and mifepristone.

Another approach uses the combination of tamoxifen and misoprostol. The administration of tamoxifen (20 mg daily for 4 days) followed by misoprostol (800 µg vaginally, with a second dose if necessary 24 hours later) was associated with a 92% rate of complete abortion in 100 women with pregnancies less than 9 weeks' gestational age.<sup>213</sup> Similar good results were obtained in a comparison of tamoxifen (20 mg b.i.d. for 4 days) with methotrexate.<sup>214</sup>

The use of prostaglandin alone has also been pursued.<sup>215</sup> Relatively high success rates have been reported with multiple dosing,<sup>216</sup> but the most effective regimen and the best method of administration remain to be determined.<sup>217</sup> The administration of 800 µg misoprostol daily for 3 days has been reported to be very effective late in the first trimester (10–12 weeks).<sup>218</sup> In very early gestation, a single vaginal dose of 800 µg misoprostol or multiple doses within 24 hours is as effective as the usual combination of mifepristone and oral misoprostol.<sup>216,219</sup>

One word of caution regarding misoprostol, the synthetic prostaglandin E<sub>1</sub> analog: it is now recognized that infants born to pregnant women exposed to misoprostol have an increased risk of abnormal vascular development resulting in Möbius syndrome (congenital facial paralysis with or without limb defects) and defects such as equinovarus and arthrogyposis.<sup>220,221,222</sup> Although the risk is low, this possibility must be considered in decision-making when the various methods for first-trimester abortion are considered.

Careful prospective follow-up assessments can detect no health differences in women who have medical abortions compared with women who have abortions by vacuum aspiration.<sup>223</sup> Although women having medical abortions experience more

bleeding and cramping, with appropriate counseling and support, women are equally satisfied with surgical and medical abortions.<sup>224</sup>

# Complications of Abortions

Postoperative complications of elective abortions are classified as either immediate or delayed. Uterine perforation and uterine atony are examples of immediate complications. Delayed complications can occur several hours to several weeks after the operation. These usually present according to the major complaint: bleeding, pain, and continuing symptoms of pregnancy.

## Bleeding

By far, the most common cause of unusually heavy postabortal bleeding is retained products of conception. Rates in large series vary from 0.2% to 0.6%.<sup>149</sup> Patients with retained products of conception occasionally present several weeks after an abortion, but most report excessive bleeding within 1 week. Severe pain or pelvic tenderness suggests that infection is also present. Treatment is prompt aspiration of the uterus with the largest cannula that will pass the cervix.

## Infection

Infection is sometimes marked by uterine bleeding; although without retained products of conception, the volume of blood loss is usually modest. Fever and uterine tenderness are the most common signs of postabortal endometritis, occurring in about 0.5% of cases.<sup>149</sup> Some studies indicate that prophylactic antibiotics reduce the risk of surgical postabortal infection.<sup>225,226</sup> Most clinicians agree that women at risk of pelvic infection benefit from the use of prophylactic antibiotics prior to induced abortion; others state that women who have not had a previous delivery should receive prophylaxis, and still others believe that all abortion patients would benefit from prophylactic antibiotics.<sup>227,228</sup> A meta-analysis of antibiotics at the time of surgically induced abortion unequivocally concluded that prophylactic antibiotics should be routinely used without exceptions, and, as noted previously, prophylactic antibiotics are now advocated for medical abortions.<sup>198,229</sup> Because both gonorrhea and chlamydia, as well as other organisms, can cause postabortion infections, a tetracycline seems the best drug for prophylaxis. Doxycycline, 100 mg an hour before the surgical abortion and 200 mg 30 minutes afterward, is the most convenient and comprehensive regimen.<sup>230</sup> Tetracycline, 500 mg once before and once after the operation, is also acceptable. Metronidazole, 400 mg an hour before and 4–8 hours afterward, has been tested and is effective treatment for patients with bacterial vaginosis detected at the time of abortion.<sup>231,232</sup> The treatment of choice for medical abortions is doxycycline 100 mg b.i.d. for 7 days beginning on the day of mifepristone.

Patients who present with uterine tenderness, fever, and bleeding require uterine aspiration and antibiotic treatment. Patients who have fevers higher than 38°C (101°F), signs of peritoneal inflammation, and uterine tenderness require hospitalization and intravenous antibiotics active against anaerobes, gonorrhea, and chlamydia. Outpatient treatment with doxycycline, 100 mg b.i.d. for 14 days, should be reserved for patients whose signs and symptoms are confined to the uterus.

## **Dysfunctional Uterine Bleeding Following Abortion**

Women may present with uterine bleeding but without signs or symptoms of retained products of conception or infection. When these two diagnoses have been ruled out by absence of fever, a closed cervix, and a nontender uterus, the bleeding itself can be treated hormonally. Curettage is rarely necessary unless bleeding is excessive.

## **Ectopic Pregnancy**

Failure to diagnose ectopic pregnancy at the time of induced abortion can cause a patient to return with complaints of persistent bleeding with or without pelvic pain. Careful examination of the uterine aspirate for villi at the time of abortion should make a missed ectopic pregnancy an unusual cause of delayed bleeding. If, however, a patient presents with this possibility, quantitative measurement of chorionic gonadotropin and vaginal ultrasonography should be used for accurate diagnosis and management. Further, while quite rare, a heterotopic pregnancy may have been present initially resulting in villi present in the aspirate and a persistent ectopic pregnancy.

## **Cervical Stenosis**

Patients who experience amenorrhea or hypomenorrhea and cyclic uterine pain after first-trimester abortion may have stenosis of the internal os. This condition occurs in about 0.02% of cases and is more common among women whose abortions are performed in the early first trimester with a minimum of cervical dilation and a small-diameter, flexible plastic cannula.<sup>149</sup> Possibly, the tip of this type of cannula abrades the internal os, and the minimal dilation allows the abraded areas to heal in contact. The condition is easily treated with cervical dilation with Pratt dilators under paracervical block.

## **Other Late Complications**

Amenorrhea, usually without pain, can be caused by Asherman syndrome, destruction and scarring of the endometrium. This condition is very rare and usually follows endometrial infection. This problem is best diagnosed and treated at hysteroscopy.

While complete scarring of the endometrial cavity is rare, increased risk of intrauterine adhesion formation is associated with the use of a sharp curette and multiple surgical procedures.<sup>233</sup>

Sensitization of Rh-negative women should be prevented. Approximately 4% of these women become sensitized following an induced abortion (the later the abortion, the higher the proportion).<sup>260</sup> Subsequent hemolytic disease of the newborn can be prevented by administering 50  $\mu$ g (250 IU) Rh immunoglobulin to all Rh-negative, D-negative women undergoing early abortion. The standard calculated dose is administered for second-trimester abortion.

# ABORTION IN THE SECOND TRIMESTER

---

The great majority (90%) of induced abortions occur in the first trimester. Four percent of abortions occur after 16 weeks' gestation.<sup>234</sup> The most common reasons for delays in seeking abortion are a failure to recognize pregnancy, a poor understanding of payment mechanisms, and awkward or confusing referral processes.<sup>235</sup>

Second-trimester abortions can be accomplished surgically or medically. After about 14 weeks of pregnancy, the surgical procedure is termed dilation and evacuation (D&E). Several approaches have been used for the medical termination of pregnancy. These include the vaginal, intramuscular, or intra-amniotic administration of prostaglandins and the intra-amniotic injection of hypertonic saline or urea, but these medications have been replaced by misoprostol and mifepristone. The D&E procedure has been considered safer and less expensive than the medical methods and better tolerated (and thus preferred) by patients.<sup>236,237,238,239,240</sup>

With surgical abortion in the second trimester, the training, experience, and skills of the surgeon are the primary factors that limit the gestational age at which abortion can be safely performed. Advanced gestational age by itself incurs increased risks for all types of complications. These are multiplied when the duration of pregnancy is discovered, after beginning uterine evacuation, to be beyond the experience and skill of the surgeon or capacity of the equipment. Uterine perforation, infection, bleeding, amniotic fluid embolism, and anesthetic reactions are increased as gestational age increases.<sup>236</sup>

When errors in estimating gestational age require the surgeon to use unfamiliar instruments or techniques that are not frequently practiced, the increased duration of the procedure can cause problems. Efforts to sedate or relieve pain by administering additional drugs increase the risk of toxic reactions or overdose. If a change from local to general anesthesia is undertaken, the patient is at much greater risk of anesthetic complications. Finally, if complications caused by advanced gestational age necessitate transfer of the patient to physicians who are not familiar with uterine evacuation techniques, the patient may undergo unnecessarily extensive surgery, such as hysterectomy, with all the risks inherent in emergency procedures.

Preoperative cervical dilation with osmotic dilators makes first-trimester abortion safer and easier and is essential for second-trimester abortion. Local anesthesia instead of general anesthesia also makes abortion safer.<sup>241,242</sup> Some patients are not good candidates for surgical procedures of any kind under local anesthesia, and others may have special reasons to prefer that an abortion be performed under general anesthesia. Patient requests should be seriously considered, but the clinician also has a responsibility to inform the patient of the risks and benefits of local versus general

anesthesia.

The medical method of induced abortion in the first trimester is also effective for second-trimester abortions. A combination of the progesterone antagonist, mifepristone, (a single oral 200-mg dose of mifepristone administered 36 hours before prostaglandin treatment) and 800-mg misoprostol administered orally or vaginally is highly effective.<sup>243,244</sup> If mifepristone is unavailable, misoprostol on its own, 400 mg every 3 or 4 hours for a total of five doses, can be used, as well as oxytocin.<sup>245</sup>



# POSTABORTION CONTRACEPTION

---

Despite improvements in contraceptive technology, unintended pregnancies lead to millions of spontaneous and voluntary abortions, unwanted births, and ectopic pregnancies in the United States and worldwide.<sup>1</sup> Social and economic disparities are associated with high rates of unintended pregnancies and induced abortions, especially among adolescents.<sup>246</sup> Contraception plays an important role in rectifying disparities and protecting women's health; at no time is access to effective methods more important than immediately after induced abortion. Adolescents are especially receptive to contraception counseling that is provided immediately after an induced abortion.<sup>247</sup>

Barriers to effective contraceptive use vary around the world. In the United States, where nearly half of induced abortions are repeat procedures, failure to receive contraception and alcohol and drug use are strongly associated with an increased risk of repeat abortion.<sup>179</sup> Comprehensive counseling about contraceptive options is not always incorporated into abortion care, and this failure explains many repeat abortions.<sup>248</sup> Studies indicate that family planning counseling in an abortion clinic is well accepted and promotes modern contraceptive use.<sup>248,249</sup>

Women who terminate pregnancies are at high risk of having another unintended pregnancy.<sup>250</sup> Clinicians should seize the opportunity to assist women who are highly motivated to implement contraception. An ideal time to provide contraception is promptly after treatment for an unsafe abortion, especially in women at high risk of subsequent unintended pregnancies because of lack of access to contraception.<sup>251</sup> Postabortion contraceptive counseling and initiation of contraceptive methods on the day of abortion are associated with increased continuation rates.

The safety of immediate placement of an IUD, etonogestrel implant, injection of depot medroxyprogesterone acetate, and initiation of oral contraceptives following first- and second-trimester abortions is well documented. Data regarding other methods (progestin-only pills, Norplant, transdermal, and vaginal methods) can be extrapolated from studies of postpartum women.<sup>252</sup>

Immediate post-first-trimester abortion IUD placement is known to be safe and effective, but information about the second trimester is more limited. A prospective cohort study of 256 women demonstrated a low rate of expulsion (3%) and discontinuation (8.3%), with a high rate of IUD acceptance, following a second-trimester surgical abortion.<sup>253</sup> The rate of infection was not significantly increased. A Cochrane meta-analysis of postabortion IUD placement (nine randomized trials including first- and second-trimester abortions) concluded that expulsion rates were higher with all IUD types than in interval placement.<sup>254</sup> More recently, a randomized

trial of IUD insertion after first-trimester surgical abortion indicated no major difference in expulsion rates comparing immediate insertion with delayed insertion and no increase in the risk of infection.<sup>255,256</sup> Of note is the study indicating that the risk of repeat abortion is decreased among IUD users compared with other methods.<sup>257</sup>

Etonogestrel implant insertion at the time of mifepristone administration before 8 weeks' gestation was not shown to decrease the efficacy of the medical regimen and was shown to decrease subsequent pregnancy in the next 6 months as compared to routine insertion of the implant.<sup>258</sup> A second study showed once again that the etonogestrel implant placed at the time of mifepristone did not decrease efficacy of the abortion, but also did not show decreased pregnancy rates. It did show that patients assigned to immediate placement were more satisfied with their care.<sup>259</sup>

In summary, IUD insertion, etonogestrel implant insertion, and the immediate start of depot medroxyprogesterone acetate, progestin-only pills, and barrier methods are indicated following either a first- or second-trimester abortion. After the elective termination of a pregnancy of less than 12 weeks, estrogen-progestin contraception can be started immediately. After a pregnancy of 12 or more weeks, estrogen should not be started until the 3rd postpartum week to avoid the postpartum risk of venous thromboembolism. Information about the rates of subsequent unintended pregnancies for newer methods of contraception following second-trimester abortion is limited; however, initiation of all hormonal methods of contraception immediately following a second-trimester abortion is endorsed by the World Health Organization and reduces the risk of repeat abortion. The vaginal ring and the contraceptive patch are assumed to have the same efficacy and safety as oral contraceptives. The abortion setting is an ideal time to provide a contraceptive method like IUDs and implants, which require a skilled clinician for insertion.

# REFERENCES

1. **Sedgh G, Singh S, Hussain R**, Intended and unintended pregnancies worldwide in 2012 and recent trends. *Stud Fam Plann* 45:301, 2014.
2. **Sedgh G, Finer LB, Bankole A, Eilers MA, Singh S**, Adolescent pregnancy, birth, and abortion rates across countries, *J Adolesc Health* 56:223, 2015.
3. **Finer LB, Zolna MR**, Declines in unintended pregnancy in the United States, 2008–2011, *N Engl J Med* 374:9, 2016.
4. **Lesesne CA, Lewis K, Fisher D**, Promoting Science-Based Approaches to Teen Pregnancy Prevention Using Getting to Outcomes for Teen Pregnancy Prevention (PSBA-GTO), Centers for Disease Control and Prevention, Atlanta, 2006.
5. **Martin JA, Hamilton BE, Osterman MJK, Driscoll AK, Mathews TJ**, Births: final data for 2015, *Natl Vital Stat Rep* 66:1, 2017.
6. **Santelli JS, Lindberg LD, Finer LB, Singh S**, Explaining recent declines in adolescent pregnancy in the United States: the contribution of abstinence and improved contraceptive use, *Am J Public Health* 97:150, 2007.
7. **Lindberg LD**, Changes in formal sex education: 1995–2002, *Persp Sexual Reprod Health* 38:182, 2006.
8. **Kirby D**, Emerging Answers 2007. Research Findings on Programs to Reduce Teen Pregnancy and Sexually Transmitted Diseases, The National Campaign to Prevent Teen and Unplanned Pregnancy, [http://www.thenationalcampaign.org/EA2007/EA2007\\_full.pdf](http://www.thenationalcampaign.org/EA2007/EA2007_full.pdf), 2007.
9. **Mueller TE, Gavin LE, Kulkarni A**, The association between sex education and youth's engagement in sexual intercourse, age at first intercourse, and birth control use at first sex, *J Adolesc Health* 42:89, 2008.
10. **Kavanaugh ML, Jerman J, Finer LB**, Changes in use of long-acting reversible contraceptive methods among U.S. women, 2009–2012, *Obstet Gynecol* 126(5):917, 2015.
11. **Guttmacher Institute**, Fact sheet: contraceptive use in the United States, <https://www.guttmacher.org/fact-sheet/contraceptive-use-united-states>, 2016.
12. **Daniels K, Daugherty J, Jones J, Mosher W**, Current contraceptive use and variation by selected characteristics among women aged 15–44 in the United States, 2011–2013, *Natl Health Stat Rep* 86(1):1, 2015.
13. **Alkema L, Kantorova V, Menozzi C, Biddlecorn A**, National, regional, and global rates and trends in contraceptive prevalence and unmet need for family planning between 1990 and 2015: a systematic and comprehensive analysis, *Lancet* 381:1642, 2013.
14. **Trussell J, Hatcher RA, Cates Jr W, Stewart FH, Kost K**, A guide to interpreting contraceptive efficacy studies, *Obstet Gynecol* 76:558, 1990.
15. **Trussell J**, Contraceptive failure in the United States, *Contraception* 83:397, 2011.
16. **Trussell J**, Contraceptive efficacy of the reality female condom, *Contraception* 58:147, 1998.
17. **Trussell J, Vaughan B**, Contraceptive failure, method-related discontinuation and resumption of use: results from the 1995 National Survey of Family Growth, *Fam Plann Perspect* 31:64, 1999.
18. **Pearl R**, Factors in human fertility and their statistical evaluation, *Lancet* 222:607, 1933.
19. **Chandra A, Martinez GM, Mosher WD, Abma JC, Jones J**, Fertility, Family Planning, and Reproductive Health of U.S. Women: Data from the 2002 National Survey of Family Growth, National Center for Health Statistics Series 23: No. 25, 2005.
20. **Mosher WD, Martinez GM, Chandra A, Abma JC, Willson SJ**, Use of Contraception and Use of Family Planning Services in the United States: 1982–2002, Advance Data from Vital and Health Statistics, Report No. 350, National Center for Health Statistics, 2004.
21. **Mosher WD, Pratt WF**, Contraceptive Use in the United States, 1973–88, Advance data from vital and health statistics, Report No. 182, National Center for Health Statistics, Washington, 1990.
22. **Mosher WD**, Use of family planning services in the United States: 1982 and 1988, Advance data from vital and health statistics. Report No. 184, National Center for Health Statistics, Washington, 1990.
23. **Abma JC, Chandra A, Mosher WD, Peterson L, Piccinino L**, Fertility, Family Planning, and Women's Health: New Data from the 1995 National Survey of Family Growth, Report No. 19, Series 23, National Center

for Health Statistics, Washington, 1997.

24. **Jones J, Mosher W, Daniels K**, Current Contraceptive Use in the United States, 2006–2010, and Changes in Patterns of Use Since 1995, Report No. 60, National Center for Health Statistics, Washington, 2012.
25. **Polaneczky M, Slap G, Forke C, Rappaport A, Sondheimer S**, The use of levonorgestrel implants (Norplant) for contraception in adolescent mothers, *New Engl J Med* 331:1201, 1994.
26. **Polaneczky M, Guarnaccia M, Alon J, Wiley J**, Early experience with the contraceptive use of depo-medroxyprogesterone acetate in an inner-city population, *Fam Plann Perspect* 28:174, 1996.
27. **Abraham M, Zhao Q, Peipert JF**, Young age, nulliparity, and continuation of long-acting reversible contraceptive methods, *Obstet Gynecol* 126:823, 2015.
28. **Diedrich JT, Zhao Q, Madden T, Secura GM, Peipert JF**, Three-year continuation of reversible contraception, *Am J Obstet Gynecol* 662, 2015.
29. **Canada Contraception Consensus**, Contraception in Canada, *J Obstet Gynecol Canada*, 2015.
30. **Office for National Statistics**, Contraception and Sexual Health 2007/2008, [http://www.statistics.gov.uk/downloads/theme\\_health/contra2007-8.pdf](http://www.statistics.gov.uk/downloads/theme_health/contra2007-8.pdf), July 1, 2009.
31. **Bajos N, Bohet A, Le Guen M, Moreau C**, Contraception in France: new contexts, new practices? *Popul Soc* 492:1, 2012.
32. **United Nations**, The world at six billion, <http://www.un.org/esa/population/publications/sixbillion/sixbilpart1.pdf>, 2009.
33. **Population Reference Bureau**, 2017 World Population Data Sheet, U.S. Agency of International Development, Washington, 2017.
34. **Guttmacher Institute**, Unmet need for contraception in developing countries: examining women's reasons for not using a method, <http://www.guttmacher.org/report/unmet-needs-for-contraception-in-developing-countries>, 2016.
35. **UNICEF**, Current status + progress: maternal mortality, <https://data.unicef.org/topic/maternal-health/maternal-mortality>, 2017.
36. **Bernabé-Ortiz A, White PJ, Carcamo CP, Hughes JP, Gonzales MA, Garcia PJ, Garnett GP, Holmes KK**, Clandestine induced abortion: prevalence, incidence and risk factors among women in a Latin American country, *Can Med Assoc J* 180:298, 2009.
37. **Jones RK, Darroch JE, Henshaw SK**, Contraceptive use among U.S. women having abortions in 2000–2001, *Perspect Sex Reprod Health* 34:294, 2002.
38. **Frost JJ, Sonfield A, Zolna MR, Finer LB**, Return on investment: a fuller assessment of the benefits and cost savings of the US publicly funded family planning program, *Milbank Q* 92:696, 2014.
39. **Forrest JD, Singh S**, Public-sector savings resulting from expenditures for contraceptive services, *Fam Plann Perspect* 22:6, 1990.
40. **Meier KJ, McFarlane DR**, State family planning and abortion expenditures: their effect on public health, *Am J Public Health* 84:1468, 1994.
41. **Peipert JF, Gutmann J**, Oral contraceptive risk assessment: a survey of 247 educated women, *Obstet Gynecol* 82:112, 1993.
42. **Murphy P, Kirkman A, Hale RW**, A national survey of women's attitudes toward oral contraception and other forms of birth control, *Womens Health Issues* 5:94, 1995.
43. **Picardo CM, Nichols MD, Edelman A, Jensen JT**, Women's knowledge and sources of information on the risks and benefits of oral contraception, *J Am Med Women's Assoc* 58:112, 2003.
44. **Grossman D, Fernandez L, Hopkins K, Amastae J, Potter JE**, Perceptions of the safety of oral contraceptives among a predominantly Latina population in Texas, *Contraception* 81:254, 2010.
45. **EngenderHealth**. Contraceptive sterilization: global issues and trends. Chapter 2: Sterilization Incidence and Prevalence. EngenderHealth, New York, 2002.
46. **Speert H**, *Obstetric & Gynecologic Milestones Illustrated*, The Parthenon Publishing Group, New York, 1996.
47. **Lungren SS**, A case of cesarean section twice successfully performed on the same patient, with remarks on the time, indications, and details of the operation, *Am J Obstet* 14:78, 1881.
48. **Baird D**, The fifth freedom, *Br Med J* i:234, 1966.

49. **Giovannucci E, Tosteson TD, Speizer FE, Vessey MP, Colditz GA**, A long-term study of mortality in men who have undergone vasectomy, *New Engl J Med* 326:1392, 1992.
50. **Layde PM, Ory HW, Peterson HB, Scally MJ, Greenspan JR, Smith JC, Fleming D**, The declining lengths of hospitalization for tubal sterilizations, *JAMA* 245:714, 1981.
51. **Escobedo LG, Peterson HB, Grubb GS, Franks AL**, Case fatality rates for tubal sterilization in U.S. hospitals, *Am J Obstet Gynecol* 160:147, 1989.
52. **U.S. National Center for Health Statistics**, Vital Stat US, <https://www.cdc.gov/reproductivehealth/maternalinfanthealth/pregnancy-mortality-surveillance-system.htm>, 2014.
53. **Peterson HB, Huber DH, Belker AM**, Vasectomy: an appraisal for the obstetrician-gynecologist, *Obstet Gynecol* 76:568, 1990.
54. **Barone MA, Nazerli H, Cortes M, Chen-Mok M, Pollack AE, Sokal D**, A prospective study of time and number of ejaculations to azoospermia after vasectomy by ligation and excision, *J Urol* 170:892, 2003.
55. **Griffin T, Tooher R, Nowakowski K, Lloyd M, Maddern G**, How little is enough? The evidence for post-vasectomy testing, *J Urol* 174:29, 2005.
56. **Peterson HB, Xia Z, Hughes JM, Wilcox LS, Tylor LR, Trussell J**, The risk of pregnancy after tubal sterilization: findings from the U.S. Collaborative Review of Sterilization, *Am J Obstet Gynecol* 174:1161, 1996.
57. **Peterson HB**, Sterilization, *Am J Obstet Gynecol* 111: 189, 2008.
58. **Lichterg E, Laff S, Friedman E**, Value of routine dilatation and curettage at the time of interval sterilization, *Obstet Gynecol* 67:763, 1986.
59. **Peterson HB, Xia Z, Hughes JM, Wilcox LS, Tylor LR, Trussell J; for the U.S. Collaborative Review of Sterilization Working Group**, The risk of ectopic pregnancy after tubal sterilization, *New Engl J Med* 336:762, 1997.
60. **Miesfeld R, Gaarontans R, Moyers T**, Vaginal tubal sterilization. Is infection a significant risk? *Am J Obstet Gynecol* 137:183, 1980.
61. **Levanon K, Crum C, Drapkin R**, New insights into the pathogenesis of serous ovarian cancer and its clinical impact, *J Clin Oncol* 26:5284, 2008.
62. **Dubeau L**, The cell of origin of ovarian epithelial tumours, *Lancet Oncol* 9:1191, 2008.
63. **Salvador S, Gilks B, Köbel M, Huntsman D, Rosen B, Miller D**, The fallopian tube: primary site of most pelvic high-grade serous carcinomas, *Int J Gynecol Cancer* 19:58, 2009.
64. **Hankinson SE, Hunter DJ, Colditz GA, Willett WC, Stampfer MJ, Rosner B, Hennekens CH, Speizer FE**, Tubal sterilization, hysterectomy, and risk of ovarian cancer. A prospective study, *JAMA* 270:2813, 1993.
65. **Miracle-McMahill HL, Calle EE, Kosinski AS, Rodriguez C, Wingo PA, Thun MJ, Heath CW JR**, Tubal ligation and fatal ovarian cancer in a large prospective cohort study, *Am J Epidemiol* 145:349, 1997.
66. **Mori M, Harabuchi I, Miyake H, Casagrande JT, Henderson BE, Ross RK**, Reproductive, genetic, and dietary risk factors for ovarian cancer, *Am J Epidemiol* 128:771, 1988.
67. **Irwin KL, Weiss NS, Lee NC, Peterson HB**, Tubal sterilization, hysterectomy, and the subsequent occurrence of epithelial ovarian cancer, *Am J Epidemiol* 134:362, 1991.
68. **Whittemore AS, Harris R, Itnyre J; the Collaborative Ovarian Cancer Group**, Characteristics relating to ovarian cancer risk: collaborative analysis of 12 US case-control studies. II: Invasive epithelial ovarian cancers in white women, *Am J Epidemiol* 136:1184, 1992.
69. **Powell CB, Alabaster A, Simmons S, Garcia C, et al.**, Salpingectomy for sterilization: change in practice in a large integrate health care system, 2011–2016, *Obstet Gynecol* 130:961, 2017.
70. **Castellano T, Zerden M, Marsh L, Boggess K**, Risks and benefits of salpingectomy at the time of sterilization, *Obstet Gynecol Surv* 72:663, 2017.
71. **Peterson HB, Xia Z, Wilcox LS, Tylor LR, Trussell J; for the U.S. Collaborative Review of Sterilization Working Group**, Pregnancy after tubal sterilization with bipolar electrocoagulation, *Obstet Gynecol* 94:163, 1999.
72. **Penfield AJ**, The Filshie clip for female sterilization: a review of world experience, *Am J Obstet Gynecol*

182:485, 2000.

73. **Centers for Disease Control and Prevention**, Deaths following female sterilization with unipolar electrocoagulating devices, *MMWR* 30:150, 1981.
74. **Soderstrom RM, Levy BS, Engel T**, Reducing bipolar sterilization failures, *Obstet Gynecol* 74:60, 1989.
75. **Trussell J, Guilbert E, Hedley A**, Sterilization failure, sterilization reversal, and pregnancy after sterilization reversal in Quebec, *Obstet Gynecol* 101:677, 2003.
76. **Ruminjo JK, Lynam PF**, A fifteen-year review of female sterilization by minilaparotomy under local anesthesia in Kenya, *Contraception* 55:249, 1997.
77. **Layde PM, Peterson HB, Dicker RC, DeStefano F, Ruben GL, Ory HW**, Risk factors for complications of interval tubal sterilization by laparotomy, *Obstet Gynecol* 62:180, 1983.
78. **Lippes J**, Quinacrine sterilization: time for reconsideration, *Contraception* 92: 91, 2015
79. **Cooper JM, Carignan CS, Cher D, Kerin JF; Group STOPI**, Microinsert nonincisional hysteroscopic sterilization, *Obstet Gynecol* 102:59, 2003.
80. **Mino M, Arjona JE, Cordon J, Pelegrin B, Povedano B, Chacon E**, Success rate and patient satisfaction with the Essure sterilization in an outpatient setting: a prospective study of 857 women, *Br J Obstet Gynaecol* 114:763, 2007.
81. **Savage UK, Masters SJ, Smid M, Hung Y-Y, Jacobson GF**, Hysteroscopic sterilization in a large group practice. Experience and effectiveness, *Obstet Gynecol* 114:1227, 2009.
82. **Levy B, Levie MD, Childers ME**, A summary of reported pregnancies after hysteroscopic sterilization, *J Minim Invasive Gynecol* 14:271, 2007.
83. **Vancaillie TG, Anderson TL, Johns DA**, A 12-month prospective evaluation of transcervical sterilization using implantable polymer matrices, *Obstet Gynecol* 112:1270, 2008.
84. **Hillis SD, Marchbanks PA, Tylor LR, Peterson HB; for the U.S. Collaborative Review of Sterilization Working Group**, Higher hysterectomy risk for sterilized than nonsterilized women: findings from the U.S. Collaborative Review of Sterilization, *Obstet Gynecol* 91:241, 1998.
85. **Kjer J**, Sexual adjustment to tubal sterilization, *Eur J Obstet Gynecol* 35:211, 1990.
86. **Costello C, Hillis SD, Marchbanks PA, Jamieson DJ, Peterson HB; US Collaborative Review of Sterilization Working Group**, The effect of interval tubal sterilization on sexual interest and pleasure, *Obstet Gynecol* 100:511, 2002.
87. **Rulin MC, Davidson AR, Philliber SG, Graves WL, Cushman LF**, Changes in menstrual symptoms among sterilized and comparison women: a prospective study, *Obstet Gynecol* 79:749, 1989.
88. **DeStefano F, Perlman J, Peterson HB, Diamond E**, Long-term risk of menstrual disturbances after tubal sterilization, *Am J Obstet Gynecol* 152:835, 1985.
89. **Shy KK, Stergachis A, Grothaus LG, Wagner EH, Hecht J, Anderson G**, Tubal sterilization and risk of subsequent hospital admission for menstrual disorders, *Am J Obstet Gynecol* 166:1698, 1992.
90. **Thranov I, Hertz JB, Kjer JJ, Andresen A, Micic S, Nielsen J, Hancke S**, Hormonal and menstrual changes after laparoscopic sterilization by Falope-rings or Filshie-clips, *Fertil Steril* 57:751, 1992.
91. **Wilcox LS, Martinez-Schnell B, Peterson HB, Ware JH, Hughes JM**, Menstrual function after tubal sterilization, *Am J Epidemiol* 135:1368, 1992.
92. **Rulin MC, Davidson AR, Philliber SG, Graves WL, Cushman LF**, Long-term effect of tubal sterilization on menstrual indices and pelvic pain, *Obstet Gynecol* 82:118, 1993.
93. **Carmona F, Cristóbal P, Casamitjana R, Balasch J**, Effect of tubal sterilization on ovarian follicular reserve and function, *Am J Obstet Gynecol* 189:447, 2003.
94. **Fagundes ML, Mendes MC, Patta MC, Rodrigues R, Berezowski AT, de Moura MD, Yazille ME**, Hormonal assessment of women submitted to tubal ligation, *Contraception* 71:309, 2005.
95. **Gentile GP, Helbig DW, Zacur H, Park T, Lee YJ, Westhoff CL**, Hormone levels before and after tubal sterilization, *Contraception* 73:507, 2006.
96. **Dede FS, Dilbaz B, Akyuz O, Caliskan E, Kurtaran V, Dilbaz S**, Changes in menstrual pattern and ovarian function following bipolar electrocauterization of the fallopian tubes for voluntary surgical contraception, *Contraception* 73:88, 2006.

97. **Carney PI, Yao J, Lin J, Law A**, Occurrence of chronic pelvic pain, abnormal uterine bleeding, and hysterectomy post procedure among women who have undergone female sterilization procedures—a retrospective claims analysis of commercially insured women in the US, *J Minim Invasive Gynecol*, 17:31265, 2017.
98. **Peterson HB, Jeng G, Folger SG, Hillis SA, Marchbanks PA, Wilcox LS; for the U.S. Collaborative Review of Sterilization Working Group**, The risk of menstrual abnormalities after tubal sterilization. U.S. Collaborative Review of Sterilization Working Group, *New Engl J Med* 343:1724, 2000.
99. **Miller WB, Shain RN, Pasta DJ**, Tubal sterilization or vasectomy: how do married couples make the decision? *Fertil Steril* 56:278, 1991.
100. **Grubb G, Refoser H, Layde PM, Rubin GL**, Regret after decision to have a tubal sterilization, *Fertil Steril* 44:248, 1985.
101. **Hillis SD, Marchbanks PA, Tylor LR, Peterson HB**, Poststerilization regret: findings from the United States Collaborative Review of Sterilization, *Obstet Gynecol* 93:889, 1999.
102. **Chandra A**, Surgical Sterilization in the United States: Prevalence and Characteristics, 1965–95, Vital and Health Statistics, Series 23: No. 20, National Center for Health Statistics, Hyattsville, 1998.
103. **Schmidt JE, Hillis SD, Marchbanks PA, Jeng G, Peterson HB**, Requesting information about and obtaining reversal after tubal sterilization: findings from the U.S. Collaborative Review of Sterilization, *Fertil Steril* 74:892, 2000.
104. **Curtis KM, Mohllajee AP, Peterson HB**, Regret following female sterilization at a young age: a systematic review, *Contraception* 73:205, 2006.
105. **Jamieson DJ, Kaufman SC, Cosstello C, Hillis SD, Marchbanks PA, Peterson HB; US Collaborative Review of Sterilization Working Group**, A comparison of women’s regret after vasectomy versus tubal sterilization, *Obstet Gynecol* 99:1073, 2002.
106. **Vemer HM, Colla P, Schoot DC, Willensen WN, Bierkens PB, Rolland R**, Women regretting their sterilization, *Fertil Steril* 46:724, 1986.
107. **Wilcox LS, Chu SY, Peterson HB**, Characteristics of women who considered or obtained tubal reanastomosis: results from a prospective study of tubal sterilization, *Obstet Gynecol* 75:661, 1990.
108. **Vessey M, Huggins G, Lawless M, McPherson K, Yeates D**, Tubal sterilization: findings in a large prospective study, *Br J Obstet Gynaecol* 90:203, 1983.
109. **WHO**, Mental health and female sterilization: report of a WHO collaborative study, *J Biosoc Sci* 16:1, 1984.
110. **Berger GS, Thorp JM, Weaver MA**, Effectiveness of bilateral tubotubal anastomosis in a large outpatient population, *Hum Reprod* 31:1120, 2016.
111. **Smith GL, Taylor GP, Smith KF**, Comparative risks and costs of male and female sterilization, *Am J Public Health* 75:370, 1985.
112. **Marquette CM, Koonin LM, Antarsh L, Gargiullo PM, Smith JC**, Vasectomy in the United States, 1991, *Am J Public Health* 85:644, 1995.
113. **Kendrick JS, Gonzales B, Huber DH, Grubb GS, Rubin G**, Complications of vasectomies in the United States, *J Fam Pract* 25:245, 1987.
114. **Goldacre MJ, Wotton CJ, Seagroatt V, Yeates D**, Cancer and cardiovascular disease after vasectomy: an epidemiological database study, *Fertil Steril* 84:1438, 2005.
115. **Goldacre MJ, Wotton CJ, Seagroatt V, Yeates D**, Immune-related disease before and after vasectomy: an epidemiological database study, *Hum Reprod* 22:1273, 2007.
116. **Bertero E, Hallak J, Gromatzky C, Lucon AM, Arap S**, Assessment of sexual function in patients undergoing vasectomy using the international index of erectile function, *Int Braz J Urol* 31:452, 2005.
117. **Giovanucci E, Ascherio A, Rimm EB, Colditz GA, Stampfer MJ, Willett WC**, A prospective cohort study of vasectomy and prostate cancer in US men, *JAMA* 269:873, 1993.
118. **Giovanucci E, Tosteson TD, Speizer FE, Ascherio A, Vessey MP, Colditz GA**, A retrospective cohort study of vasectomy and prostate cancer in US men, *JAMA* 269:878, 1993.
119. **Hayes RB, Pottern LM, Greenberg R, Schoenberg J, Swanson GM, Liff J, Schwartz AG, Brown LM, Hoover RN**, Vasectomy and prostate cancer in US blacks and whites, *Am J Epidemiol* 137:263, 1993.

120. **Hsing AW, Wang RT, Gu FL, Lee M, Wang T, Leng TJ, Spitz M, Blot WJ**, Vasectomy and prostate cancer risk in China, *Cancer Epidemiol Biomark Prev* 3:285, 1994.
121. **Sidney S, Quesenberry Jr CP, Sadler MC, Guess HA, Lydick EG, Cattolica EV**, Vasectomy and the risk of prostate cancer in a cohort of multiphasic health-checkup examinees: second report, *Cancer Causes Control* 2:113, 1991.
122. **Moller H, Knudsen LB, Lyng E**, Risk of testicular cancer after vasectomy: cohort study of over 73,000 men, *Br Med J* 309:295, 1994.
123. **Rosenberg L, Palmer JR, Zauber AG, Warshauer E, Strom BL, Harlap S, Shapiro S**, The relation of vasectomy to risk of cancer, *Am J Epidemiol* 140:431, 1994.
124. **Zhu K, Stanford JL, Daling JR, McKnight B, Stergachis A, Brawer MK, Weiss NS**, Vasectomy and prostate cancer: a case-control study in a health maintenance organization, *Am J Epidemiol* 144:717, 1996.
125. **Holt SK, Salinas CA, Stanford JL**, Vasectomy and the risk of prostate cancer, *J Urol* 180:2565, 2008.
126. **Schwingle PJ, Meirik O, Kapp N, Farley TM; HRP Multicenter Study of Prostate Cancer and Vasectomy**, Prostate cancer and vasectomy: a hospital-based case-control study in China, Nepal and the Republic of Korea, *Contraception* 79:363, 2009.
127. **John EM, Whittemore AS, Wu AH, Kolonel LN, Hislop TG, Howe GR, West DW, Hankin J, Dreon DM, The C-Z, Burch JD, Paffenbarger RS Jr**, Vasectomy and prostate cancer: results from a multiethnic case-control study, *J Natl Cancer Inst* 87:662, 1995.
128. **Lyng E, Knudsen LB, Müller H**, Vasectomy and testis and prostate cancer, *Fertil Control Rev* 3:8, 1994.
129. **Healey B**, Does vasectomy cause prostate cancer? *JAMA* 269:2620, 1993.
130. **Bernal-Delgado E, Latour-Pérez J, Pradas-Arnal F, Gómez-López LI**, The association between vasectomy and prostate cancer: a systematic review of the literature, *Fertil Steril* 70:191, 1998.
131. **Cox B, Sneyd MJ, Paul C, Delahunt B, Skegg DC**, Vasectomy and risk of prostate cancer, *JAMA* 287:3110, 2002.
132. **Manson JE, Ridker PM, Spelsberg A, Ajani U, Lotufo PA, Hennekens CH**, Vasectomy and subsequent cardiovascular disease in US physicians, *Contraception* 59:181, 1999.
133. **Krieger JN, Nirapathpongorn A, Chaiyaporn M, Peterson G, Nikolaeva I, Akridge R, Ross SO, Coombs RW**, Vasectomy and human immunodeficiency virus type 1 in semen, *J Urol* 159:820, 1998.
134. **Hendry WF**, Vasectomy and vasectomy reversal, *Br J Urol* 73:337, 1994.
135. **Belker AM, Thomas AJ, Fuchs EF, Konnak JM, Sharlip ID**, Results of 1,469 microsurgical vasectomy reversals by the vasovasostomy group, *J Urol* 145:505, 1991.
136. **Winters SJ, Marshall GR**, Hormonally-based male contraceptives: will they ever be a reality? *J Clin Endocrinol Metab* 73:464A, 1991.
137. **Waites GMH**, Development of methods of male contraception: impact of the World Health Organization Task Force, *Fertil Steril* 80:1, 2003.
138. **Wang C, Swerdloff RS**, Male hormonal contraception, *Am J Obstet Gynecol* 190:S60, 2004.
139. **Grimes DA, Lopez LM, Gallo MF, Halpern V, Nanda K, Schulz KF**, Steroid hormones for contraception in men, *Cochrane Database Syst Rev* CD004316, 2012.
140. **Waites GMH, Wang C, Griffin PD**, Gossypol: reasons for its failure to be accepted as a safe, reversible male antifertility drug, *Int J Androl* 21:8, 1998.
141. **Atrash HK, Strauss LT, Kendrick JS, Skjeldestad FE, Ahn YW**, The relation between induced abortion and ectopic pregnancy, *Obstet Gynecol* 89:512, 1997.
142. **Jerman J, Jones RK, Onda T**, Characteristics of U.S. Abortion Patients in 2014 and Changes Since 2008, *Guttmacher Institute*, New York, 2016.
143. **Grimes DA, Benson J, Singh S, Romero M, Ganatra B, Okonofua FE, Shah IH**, Unsafe abortion: the preventable pandemic, *Lancet* 368:1908, 2006.
144. **Jatlaoui TC, Shah J, Mandel M, Krashin JW, Suchdev DB, Jamieson DJ; Centers for Disease Control and Prevention**, Abortion surveillance: United States, 2014, *MMWR Surveill Summ* 66:1, 2017.
145. **Creanga AA, Syverson C, Seed K, Callaghan WM**, Pregnancy-related mortality in the United States, 2011–2013, *Obstet Gynecol* 130:366, 2017.



146. **Grimes DA, Schulz KF, Cates W Jr, Tyler CW Jr**, Local versus general anesthesia: which is safer for performing suction curettage abortions, *Am J Obstet Gynecol* 135:1030, 1979.
147. **Peterson HB, Grimes DA, Cates W Jr, Rubin GL**, Comparative risk of death from induced abortion at 12 weeks' gestation performed with local versus general anesthesia, *Am J Obstet Gynecol* 141:763, 1981.
148. **Buehler J, Schulz K, Grimes D, Mogue C**, The risk of serious complications from induced abortion: do personal characteristics make a difference?, *Am J Obstet Gynecol* 153:14, 1985.
149. **Hakim-Elahi E, Tovell H, Burnhill M**, Complications of first trimester abortions: a report of 170,000 cases, *Obstet Gynecol* 76:129, 1990.
150. **Hogue C**, Impact of abortion on subsequent fertility, *Clin Obstet Gynecol* 13:96, 1986.
151. **Stubblefield PG, Monson RR, Schoenbaum SC, Wolfson CE, Cookson DJ, Ryan KJ**, Fertility after induced abortion: a prospective follow-up study, *Obstet Gynecol* 63:186, 1984.
152. **Daling J, Weiss N, Voigt I, Spadoni LR, Soderstrom R, Moore DE, Stadel BV**, Tubal infertility in relation to prior induced abortion, *Fertil Steril* 43:389, 1985.
153. **Daling J, Chow W, Weiss N, Metch BT, Soderstrom R**, Ectopic pregnancy in relation to previous induced abortion, *JAMA* 253:1005, 1985.
154. **Kalish RB, Chasen ST, Rosenzweig LB, Rashbaum WK, Chervenak FA**, Impact of midtrimester dilation and evacuation on subsequent pregnancy outcome, *Am J Obstet Gynecol* 187:882, 2002.
155. **Debby A, Glezerman M, Sagiv R, Sadan O, Malinger G, Golan A**, Reproductive performance following midtrimester termination of pregnancy, *Gynecol Obstet Invest* 56:168, 2003.
156. **Skjeldestad FE, Gargiullo PM, Kendrick JS**, Multiple induced abortions as risk factor for ectopic pregnancy. A prospective study, *Acta Obstet Gynecol Scand* 76:691, 1997.
157. **Shah PS, Zao J**, Induced termination of pregnancy and low birthweight and preterm birth: a systematic review and meta-analyses, *BJOG* 116:1425, 2009.
158. **Swingle HM, Colaizy TT, Zimmerman MB, Morriss FH**, Abortion and the risk of subsequent preterm birth: a systematic review with meta-analysis, *J Reprod Med* 54:95, 2009.
159. **Saccone G, Perriera L, Berghella V**, Prior uterine evacuation of pregnancy as independent risk factor for preterm birth: a systematic review and metaanalysis, *Am J Obstet Gynecol* 214:572, 2016.
160. **Day JC**, Bureau of the Census, Current population reports. Population projections of the United States, by age, sex, race, and Hispanic origin: 1993 to 2050, U.S. Government Printing Office, Washington, DC, 1993.
161. **Tharaux-Deneux C, Bouyer J, Job-Spira N, Coste J, Spira A**, Risk of ectopic pregnancy and previous induced abortion, *Am J Public Health* 88:401, 1998.
162. **Sun Y, Che Y, Gao E, Olsen J, Zhou W**, Induced abortion and risk of subsequent miscarriage, *Int J Epidemiol* 32:449, 2003.
163. **Zhou W, Olsen J**, Are complications after an induced abortion associated with reproductive failures in a subsequent pregnancy? *Acta Obstet Gynecol Scand* 82:177, 2003.
164. **Biggs MA, Upadhyay UD, McCulloch CE, Foster DG**, Women's mental health and well-being 5 years after receiving or being denied an abortion: a prospective, longitudinal cohort study, *JAMA Psychiat* 74:169, 2017.
165. **Charles VE, Polis CB, Sridhara SK, Blum RW**, Abortion and long-term mental health outcomes: a systematic review of the evidence, *Contraception* 78:436, 2008.
166. **American Psychological Association**, Report of the APA Task Force on Mental Health and Abortion, <http://www.apa.org/releases/abortion-report.pdf>, 2008.
167. **Andrieu N, Clavel F, Gairard B, Piana L, Bremond A, Lansac JH, Flamant R, Renaud R**, Familial risk of breast cancer and abortion, *Cancer Detect Prev* 18:51, 1994.
168. **Daling JR, Malone KE, Voigt LF, White E, Weiss NS**, Risk of breast cancer among young women: relationship to induced abortion, *J Natl Cancer Inst* 86:1584, 1994.
169. **Rookus MA, van Leeuwen FE**, Induced abortion and risk for breast cancer: reporting (recall) bias in a Dutch case-control study, *J Natl Cancer Inst* 88:1759, 1996.
170. **Melbye M, Wohlfahrt J, Olsen JH, Frisch M, Westergaard T, Helweg-Larsen K, Andersen PK**, Induced abortion and the risk of breast cancer, *New Engl J Med* 336:81, 1997.

171. **Ye Z, Gao DL, Qin Q, Ray RM, Thomas DB**, Breast cancer in relation to induced abortion in a cohort of Chinese women, *Br J Cancer* 87:977, 2002.
172. **Mahue-Giangreco M, Ursin G, Sullivan-Halley J, Berstein L**, Induced abortion, miscarriage, and breast cancer of young women, *Cancer Epidemiol Biomarkers Prev* 12:209, 2003.
173. **Brewster DH, Stockton DL, Dobbie R, Bull D, Beral V**, Risk of breast cancer after miscarriage or induced abortion: a Scottish record linkage case-control study, *J Epidemiol Community Health* 59:283, 2005.
174. **Michels KB, Xue F, Colditz GA, Willett WC**, Induced and spontaneous abortion and incidence of breast cancer among young women. A prospective cohort study, *Arch Intern Med* 167:814, 2007.
175. **Ganatra B, Gerds C, Rossier C**, et al., Global, regional and subregional classification of abortions by safety, 2010–14: estimates from a Bayesian hierarchical model, *Lancet* 390:2372, 2017.
176. **Jerman J, Jones RK**, Secondary measures of access to abortion services in the United States, 2011 and 2012: gestational age limits, cost, and harassment, *Womens Health Issues* 24:e419, 2014.
177. **Jones RK, Jerman J**, Abortion incidence and service availability in the United States, 2014, *Perspect Sex Reprod Health* 49:17, 2017.
178. **Landy U**, Abortion counseling—a new component of medical care, *Clin Obstet Gynecol* 13:33, 1986.
179. **Prager SW, Steinauer JE, Foster DG, Darney PD, Drey EA**, Risk factors for repeat elective abortions, *Am J Obstet Gynecol* 197:575.e1, 2007.
180. **Darney PD, Atkinson E, Hirabayashi K**, Uterine perforation during second trimester abortion by cervical dilation and instrumental extraction: a review of 15 cases, *Obstet Gynecol* 75:441, 1990.
181. **World Health Organization Task Force on Postovulatory Methods of Fertility Regulation**, Cervical ripening with mifepristone (RU-486) in late first trimester abortion, *Contraception* 50:461, 1994.
182. **MacIsaac L, Grossman D, Balistreri E, Darney P**, A randomized controlled trial of laminaria, oral misoprostol, and vaginal misoprostol before abortion, *Obstet Gynecol* 93:766, 1999.
183. **Virk J, Zhang J, Olsen J**, Medical abortion and the risk of subsequent adverse pregnancy outcomes, *New Engl J Med* 357:648, 2007.
184. **Jensen JT, Astley SJ, Morgan E, Nichols M**, Outcomes of suction curettage and mifepristone abortion in the United States. A prospective comparison study, *Contraception* 59:153, 1999.
185. **Niinimäki M, Pouta A, Bloigu A, Gissler M, Hemminki E, Suhonen S, Heikinheimo O**, Immediate complications after medical compared with surgical termination of pregnancy, *Obstet Gynecol* 114:795, 2009.
186. **El-Rafaey HJ, Rajasekar D, Abdalla M, Calder L, Templeton A**, Induction of abortion with mifepristone (RU 486) and oral or vaginal misoprostol, *New Engl J Med* 332:983, 1995.
187. **Silvestre L, Dubois C, Renault M, Rezvani Y, Baulieu EE, Ulmann A**, Voluntary interruption of pregnancy with Mifepristone (RU 486) and a prostaglandin analogue, *New Engl J Med* 322:645, 1990.
188. **Fiala C, Gemzell-Danielsson K**, Review of medical abortion using mifepristone in combination with a prostaglandin analogue, *Contraception* 74:66, 2006.
189. **Thong KJ, Baird DT**, Induction of abortion with mifepristone and misoprostol in early pregnancy, *Br J Obstet Gynaecol* 99:1004, 1992.
190. **Peyron R, Aubeny E, Targosz V, Silvestre L, Renault M, Elkik F, Leclerc P, Ulmann A, Baulieu EE**, Early termination of pregnancy with mifepristone (RU 486) and the orally active prostaglandin misoprostol, *New Engl J Med* 328:1509, 1993.
191. **Schaff EA, Eisinger SH, Stadalius LS, Franks P, Gore BZ, Poppema S**, Low-dose mifepristone 200 mg and vaginal misoprostol for abortion, *Contraception* 59:1, 1999.
192. **Schaff EA, Fielding SL, Westhoff C, Ellertson C, Eisinger SH, Stadalius LS, Fuller L**, Vaginal misoprostol administered 1, 2, or 3 days after mifepristone for early medical abortion: a randomized trial, *JAMA* 284:1948, 2000.
193. **Ashok PW, Penney GC, Flett GMM, Templeton A**, An effective regimen for early medical abortion: a report of 2000 consecutive cases, *Hum Reprod* 13:2962, 1998.
194. **Schaff EA, Fielding SL, Westhoff C**, Randomized trial of oral versus vaginal misoprostol 2 days after mifepristone 200 mg for abortion up to 63 days of pregnancy, *Contraception* 66:247, 2002.
195. **Hamoda H, Ashok PW, Flett GMM, Templeton A**, Medical abortion at 64 to 91 days of gestation: a

review of 483 consecutive cases, *Am J Obstet Gynecol* 188:1315, 2003.

196. **von Hertzen H, Honkanen H, Piaggio G, Bartfai G, Erdenetungalag R, Gemzell-Danielsson K, Gopalan S, Horga M, Jerve F, Mittal S, Ngoc NT, Peregoudov A, Prasad RN, Pretnar-Darovec A, Shah RS, Song S, Tang OS, Wu SC; WHO Research Group on Post-ovulatory Methods of Fertility Regulation**, WHO multinational study of three misoprostol regimens after mifepristone for early medical abortion. I: Efficacy, *Br J Obstet Gynaecol* 110:808, 2003.
197. **Fischer M, Bhatnagar J, Guarner J, Reagan S, Hacker JK, Van Meter SH, Poukens V, Whiteman DB, Iton A, Cheung M, Dassey DE, Shieh W-J, Zaki SR**, Fatal toxic shock syndrome associated with *Clostridium sordelli* after medical abortion, *New Engl J Med* 353:2352, 2005.
198. **Fjerstad M, Trussell J, Sivin I, Lichtenberg ES, Cullins V**, Rates of serious infection after changes in regimens for medical abortion, *New Engl J Med* 361:145, 2009.
199. **Meckstroth K, Whitaker A, Bertisch S, Goldberg A, Darney P**, Misoprostol administered by epithelial routes: drug absorption and uterine response, *Obstet Gynecol* 108:582, 2006.
200. **Winikoff B, Dzuba IG, Creinin MD, Crowden WA, Goldberg AB, Gonzales J, Howe M, Moskowitz J, Prine L, Shannon CS**, Two distinct oral routes of misoprostol in mifepristone medical abortion: a randomized controlled trial, *Obstet Gynecol* 112:1303, 2008.
201. **Kapp N, Baldwin MK, Rodriguez MI**, Efficacy of medical abortion prior to 6 gestational weeks: a systematic review, *Contraception* 2018;97(2):90–99.
202. **Cohen AL, Bhatnagar J, Reagan S, Zane SB, D'Angeli MA, Fischer M, Killgore G, Dwan-Gett TS, Blossom DB, Shieh WJ, Guarner J, Jernigan J, Duchin JSZ, Zaki SR, McDonald LC**, Toxic shock associated with *Clostridium sordellii* and *Clostridium perfringens* after medical and spontaneous abortion, *Obstet Gynecol* 110:1027, 2007.
203. **Ashok PW, Flett GM, Templeton A**, Termination of pregnancy at 9–13 weeks' amenorrhoea with mifepristone and misoprostol, *Lancet* 352:542, 1998.
204. **Baird DT, Brown A, Cheng L, Critchley HO, Lin S, Narvekar N, Williams AR**, Mifepristone: a novel estrogen-free daily contraceptive pill, *Steroids* 68:1099, 2003.
205. **Lakha F, Ho PC, Van der Spuy ZM, Dada K, Elton R, Glasier AF, Critchley HO, Williams AR, Baird DT**, A novel estrogen-free oral contraceptive pill for women: multicentre, double-blind, randomized controlled trial of mifepristone and progestogen-only pill (levonorgestrel), *Hum Reprod* 22:2428, 2007.
206. **Creinin MD, Vittinghoff E, Keder L, Darney PD, Tiller G**, Methotrexate and misoprostol for early abortion: a multicenter trial. I. Safety and efficacy, *Contraception* 53:321, 1996.
207. **Creinin MD**, Medical abortion with methotrexate 75 mg intramuscularly and vaginal misoprostol, *Contraception* 56:367, 1997.
208. **Creinin MD**, Oral methotrexate and vaginal misoprostol for early abortion, *Contraception* 54:15, 1996.
209. **Creinin M, Darney P**, Methotrexate and misoprostol for early abortion, *Contraception* 48:339, 1993.
210. **Creinin MD, Vittinghoff E**, Methotrexate and misoprostol vs misoprostol alone for early abortion. A randomized controlled trial, *JAMA* 272:1190, 1994.
211. **Creinin MD, Park M**, Acceptability of medical abortion with methotrexate and misoprostol, *Contraception* 52:41, 1995.
212. **Hausknecht RU**, Methotrexate and misoprostol to terminate early pregnancy, *New Engl J Med* 333:538, 1995.
213. **Mishell Jr DR, Jain JK, Byrne JD, Lacarra MDC**, A medical method of early pregnancy termination using tamoxifen and misoprostol, *Contraception* 58:1, 1998.
214. **Wiebe ER**, Tamoxifen compared to methotrexate when used with misoprostol for abortion, *Contraception* 59:265, 1999.
215. **Koopersmith TB, Mishell DR Jr**, The use of misoprostol for termination of early pregnancy, *Contraception* 53:237, 1996.
216. **Carbonell JLL, Rodríguez J, Velazco A, Tanda R, Sánchez C, Barambio S, Chami S, Valero F, Marí J, de Vargas F, Salvador I**, Oral and vaginal misoprostol 800 µg every 8 h for early abortion, *Contraception* 67:457, 2003.

217. **Blanchard K, Winikoff B, Ellertson C**, Misoprostol used alone for the termination of early pregnancy. A review of the evidence, *Contraception* 59:209, 1999.
218. **Carbonell Esteve JL, Varela L, Velazco A, Cabezas E, Tanda R, Cabezas E, Sánchez C**, Early abortion with 800 mg of misoprostol by the vaginal route, *Contraception* 59:219, 1999.
219. **Jain JK, Meckstroth KR, Mishell DR Jr**, Early pregnancy termination with intravaginally administered sodium chloride solution-moistened misoprostol tablets: historical comparison with mifepristone and oral misoprostol, *Am J Obstet Gynecol* 181:1386, 1999.
220. **Pastuszak AL, Schüler L, Speck-Martins CE, Coelho K-EFA, Cordello SM, Vargas F, Brunoni D, Schwarz IVD, Larrandaburu M, Safattle H, Meloni VFA, Koren G**, Use of misoprostol during pregnancy and Möbius' syndrome in infants, *New Engl J Med* 338:1881, 1998.
221. **Gonzalez CH, Marques-Dias MJ, Kim CA, Sugayama SMM, Da Paz JA, Huson SM, Holmes LB**, Congenital abnormalities in Brazilian children associated with misoprostol misuse in first trimester of pregnancy, *Lancet* 351:1624, 1998.
222. **Bos-Thompson MA, Hillaire-Buys D, Roux C, Faillie JL, Amram D**, Möbius syndrome in a neonate after mifepristone and misoprostol elective abortion failure, *Ann Pharmacother* 42:888, 2008.
223. **Howie FL, Henshaw RC, Naji SA, Russell IT, Templeton AA**, Medical abortion or vacuum aspiration? Two year follow-up of a patient preference trial, *Br J Obstet Gynaecol* 104:829, 1997.
224. **Elul B, Ellertson C, Winikoff B, Coyaji K**, Side effects of mifepristone-misoprostol abortion versus surgical abortion. Data from a trial in China, Cuba, and India, *Contraception* 59:107, 1999.
225. **Brewer C**, Prevention of infection after abortion with a supervised single dose of doxycycline, *Br Med J* 281:780, 1980.
226. **Hodgson JE, Major B, Portmann K, Quattlebaum FW**, Prophylactic use of tetracycline for first trimester abortions, *Obstet Gynecol* 45:574, 1975.
227. **Park T-X, Flock M, Schulz KF, Grimes DA**, Preventing febrile complications of suction curettage abortion, *Am J Obstet Gynecol* 152:252, 1985.
228. **Darj E, Stralin E, Nilsson S**, The prophylactic effect of doxycycline on postoperative infection rate after first trimester abortion, *Obstet Gynecol* 70:755, 1987.
229. **Sawaya GF, Grady D, Kerlikowske K, Grimes DA**, Antibiotics at the time of induced abortion: the case for universal prophylaxis based on a meta-analysis, *Obstet Gynecol* 87:884, 1996.
230. **Levallois P, Rioux J**, Prophylactic antibiotics for suction curettage abortion: results of a clinical controlled trial, *Am J Obstet Gynecol* 158:100, 1988.
231. **Heisterberg L, Petersen K**, Metronidazole prophylaxis in elective first trimester abortion, *Obstet Gynecol* 65:371, 1985.
232. **Larsson PG, Platz-Christensen JJ, Thejls H, Forsum U, Pahlson C**, Incidence of pelvic inflammatory disease after first trimester legal abortion in women with bacterial vaginosis after treatment with metronidazole: a double-blind, randomized study, *Am J Obstet Gynecol* 166:100, 1992.
233. Hooker
234. **Jones RK, Finer LB**, Who has second-trimester abortions in the United States? *Contraception* 85:544, 2012.
235. **Foster DG, Jackson RA, Cosby K, Weitz TA, Darney PD, Drey EA**, Predictors of delay in each step leading to an abortion, *Contraception* 77:289, 2008.
236. **Peterson WF, Berry FN, Grace MR, Gulbranson CL**, Second trimester abortion by dilatation and evacuation: an analysis of 11,747 cases, *Obstet Gynecol* 62:185, 1983.
237. **Kafrissen M, Schulz K, Grimes D, Cates W Jr**, Midtrimester abortion: intra amniotic instillation of hyperosmolar urea and prostaglandin F2a v dilatation and evacuation, *JAMA* 251:916, 1984.
238. **Ferris LE, McMMain-Klein M, Colodny N, Fellows GF, Lamont J**, Factors associated with immediate abortion complications, *Can Med Assoc J* 154:1677, 1996.
239. **Lohr PA, Hayes JL, Gemzell-Danielsson K**, Surgical versus medical methods for second trimester induced abortion, *Cochrane Database Syst Rev* (1):CD006714, 2008.
240. **Grossman D, Blanchard K, Blumenthal P**, Complications after second trimester surgical and medical abortion, *Reprod Health Matters* 15(31 Suppl):173, 2008.

241. **Mackay T, Schulz K, Grimes D**, Safety of local versus general anesthesia for second trimester dilatation and evacuation abortion, *Obstet Gynecol* 66:661, 1985.
242. **Atrash H, Chelk T, Hogue C**, Legal abortion and general anesthesia, *Am J Obstet Gynecol* 158:420, 1988.
243. **Ashok PW, Templeton A, Wagaarachi PT, Flett GMM**, Midtrimester medical termination of pregnancy: a review of 1002 consecutive cases, *Contraception* 69:51, 2004.
244. **Esteve JL, Gallego FG, Llorente MP, Bermúdez SB, Sala ES, Gopnzález LV, Texidó CS**, Late second-trimester abortions induced with mifepristone, misoprostol and oxytocin: a report of 428 consecutive cases, *Contraception* 78:52, 2008.
245. **Borgatta L, Kapp N**, Clinical guidelines: labor induction abortion in the second trimester, *Contraception* 84:4, 2011.
246. **Jones RK, Kost K, Singh S, Henshaw SK, Finer LB**, Trends in abortion in the United States, *Clin Obstet Gynecol* 52:119, 2009.
247. **Truong HM, Kellogg T, McFarland W, Kang MS, Darney P, Drey EA**, Contraceptive intentions among adolescents after abortion, *J Adolesc Health* 39:283, 2006.
248. **Ceylan A, Ertem M, Saka G, Akdeniz N**, Post abortion family planning counseling as a tool to increase contraception use, *BMC Public Health* 9:20, 2009.
249. **Becker S, Bazant ES, Meyers C**, Couples counseling at an abortion clinic: a pilot study, *Contraception* 78:424, 2008.
250. **Heikinheimo O, Gissler M, Suhonen S**, Age, parity, history of abortion and contraceptive choices affect the risk of repeat abortion, *Contraception* 78:149, 2008.
251. **Madden T, Westhoff C**, Rates of follow-up and repeat pregnancy in the 12 months after first-trimester induced abortion, *Obstet Gynecol* 113:663, 2009.
252. **World Health Organization**, Medical eligibility for contraceptive use, [http://apps.who.int/rh/fertility/contraception/mec\\_story/en/index.html](http://apps.who.int/rh/fertility/contraception/mec_story/en/index.html), 2009.
253. **Drey EA, Reeves MF, Ogawa DD, Sokoloff A, Darney PD, Steinauer JE**, Insertion of intrauterine contraceptives immediately following first- and second-trimester abortions, *Contraception* 79:397, 2009.
254. **Grimes DA, Schulz K, Stanwood N**, Immediate postabortal insertion of intrauterine devices, *Cochrane Database Syst Rev* (4):CD001777, 2004.
255. **Bednarek PH, Creinin MD, Reeves MF, Cwiak C, Espey E, Jensen JT**, Immediate intrauterine device insertion following suction aspiration between 5–12 weeks gestation is safe and does not significantly increase expulsion, FIGO Meeting, Capetown, South Africa Abstract, 2009.
256. **Cwiak CA, Bednarek PH, Reeves MF, Espey E, Creinin MD**, Uterine infection following immediate or delayed postaspiration intrauterine device insertion, *Contraception* 80:210 (Abstract), 2009.
257. **Niinimäki M, Pouta A, Bloigu A, Gissler M, Hemminki E, Suhonen S, Heikinheimo O**, Frequency and risk factors for repeat abortions after surgical compared with medical termination of pregnancy, *Obstet Gynecol* 113:845, 2009.
258. **Hognert H, Kopp Kallner H, Cameron S, Nyreli C, Jawad I, et al.**, Immediate versus delayed insertion of an etonogestrel releasing implant at medical abortion—a randomized controlled equivalence trial, *Hum Reprod* 31:2484, 2016.
259. **Raymond EG, Weaver MA, Tan YL, Louie KS, Bousiequez M, et al.**, Effect of immediate compared with delayed insertion of etonogestrel implants on medical abortion efficacy and repeat pregnancy: a randomized clinical trial, *Obstet Gynecol* 127:306, 2016.
260. **Bowman J**, Thirty-five years of Rh prophylaxis, *Transfusion* 43:1661–1666, 2003.

---

# Hormonal Contraception

Contraception is commonly viewed as a modern event, a recent development in human history. On the contrary, efforts to limit reproduction predate our ability to write about it. It is only contraception with synthetic sex steroids that is recent.

# THE HISTORY OF ORAL CONTRACEPTION

---

It was not until the early 1900s that inhibition of ovulation was observed to be linked to pregnancy and the corpus luteum. Beginning in 1920, Ludwig Haberlandt, professor of physiology at the University of Innsbruck, Austria, demonstrated that ovarian extracts given orally could prevent fertility in mice. Haberlandt is acknowledged as the first to perform experiments with the aim of producing a method of hormonal contraception; he called it “hormonal sterilization.”<sup>1</sup> In the 1920s, a Viennese gynecologist, Otfried Otto Fellner, conducting experiments in his spare time, and administering ovarian and placental extracts to a variety of animals, also reported hormonal sterilization.<sup>2</sup> By 1931, Haberlandt proposed the administration of hormones for birth control. An extract named Infecundin was produced in collaboration with the Hungarian pharmaceutical company Gedeon Richter, but Haberlandt’s early death of a heart attack in 1932, at age 47, brought an end to this effort. Fellner disappeared after the annexation of Austria to Hitler’s Germany. At this time, extraction and isolation of a few milligrams of the sex steroids required starting points measured in gallons of urine or thousands of pounds of organs.

# Russell Marker

The supply problem was solved by a cantankerous iconoclast, Russell E. Marker, who completed his thesis, but not the coursework, for his Ph.D. at the University of Maryland. The following story is derived from an autobiographical article and from a 2-hour interview for the oral history archives of the Chemical Heritage Foundation in Philadelphia.<sup>3,4</sup> Marker moved to Penn State in 1935 to pursue the goal of an abundant and inexpensive supply of progesterone, and for several years, he concentrated on urine from pregnant animals. Then in 1939, Marker devised the method, called the Marker degradation, to convert a sapogenin molecule into a progestin.

Marker was convinced that the solution to the problem of obtaining large quantities of steroid hormones was to find plants in the family that includes the lily, the agave, and the yam that contained sufficient amounts of diosgenin, a plant steroid and a sapogenin, that could be used as a starting point for steroid hormone production. Marker's search for an appropriate plant took him to North Carolina, California, Arizona, and Texas. He spent his summer vacations in the Southwest and Mexico collecting sapogenin-containing plants, and his laboratory analyzed more than a hundred thousand pounds of over four hundred different species of plants. Marker discovered that the roots of the *Dioscorea* plant (a wild yam) were the richest source of sapogenins.

On a visit to Texas A&M University, Marker found a picture of a large *Dioscorea* (*Dioscorea mexicana*) in a book that he just happened to pick up and browse through while spending the night at the home of a retired botanist who was helping him collect diosgenin-containing plants. He had to make several chaotic trips to Mexico for this *Dioscorea*, plagued by lack of a plant-collecting permit, unwilling help from Mexican botanists, the entry of the United States into World War II, and his lack of ability to speak Spanish. Eventually, 10 miles outside of Orizaba, Mexico, he found a willing accomplice in a native American country store owner named Alberto Moreno.

Moreno did not speak English, but somehow, Marker conveyed his desire to obtain the *Dioscorea* that was known locally as "cabeza de negro," black tubers—and Moreno delivered. Marker took the two plants Moreno provided on a bus back to Orizaba and eventually was able to smuggle one 9–12-inch-long tuber back to Pennsylvania.

Marker used only a portion of the plant to isolate diosgenin. In February 1942, he took the remainder to the Parke-Davis chemists in Detroit with whom he had previously collaborated. Demonstrating his process for obtaining diosgenin, Marker convinced the director of research, Oliver Kamm, that he was on to something, a source for raw material that could provide for the commercial production of hormones. Unfortunately, they could not convince the president of Parke-Davis, nor could Marker convince anyone at several other companies.



Unable to obtain support from the pharmaceutical industry, Marker drew on half of his life savings and returned to Mexico in October 1942. He arranged with Albert Moreno to collect the roots of the Mexican yam. Marker paid Mexican medical students to collect the yams. The students were arrested when farmers reported that their yams were being stolen, but not before Marker had enough to prepare a syrup.

Back in the United States with his syrup, Marker arranged to work in the New York laboratory of a friend, Norman Applezweig, an organic chemist involved in steroid research, in return for one-third of whatever progesterone his syrup could yield.<sup>5</sup> He isolated diosgenin and synthesized 3 kg of progesterone, the largest lot of progesterone ever produced. US pharmaceutical companies still refused to back Marker, and even his university refused, despite Marker's urging, to patent the process.

Luckily, before Marker left Mexico, he looked through the yellow pages in a Mexico City telephone directory and found a company called "Laboratorios Hormona," owned by a lawyer who was a Hungarian immigrant, Emeric Somlo, and a German immigrant who had both a medical degree and a Ph.D. in chemistry, Frederick A. Lehman.<sup>6</sup> Visiting the company, Marker met Lehman, who had the good sense to see where this was going. From his reading of the literature, he knew who Marker was; he knew the value of steroids; and he was a businessman. Lehman called his partner who was visiting New York and convinced him to return as soon as possible. The three men agreed to form a Mexican company for the production of hormones called Syntex (from **synthesis** and **Mexico**).

In December 1943, Marker resigned from Pennsylvania State College and went to Mexico where he collected tons of *D. mexicana* roots, chopped them up with a machete, and left the pieces to dry in the sun across from Moreno's store in a small structure for drying coffee. It took 2 months of work in an old pottery shed in Mexico City to prepare several pounds of progesterone, worth \$160,000, with the help of several young women who had little education and spoke no English. Marker moved into a new four-room laboratory and, over the next year, produced over 30 kg of progesterone and 10 kg of dehydroepiandrosterone. The price of progesterone fell from \$200 to \$50 a gram.

Marker left Syntex in May 1945 due to not being paid his salary and quoted share of stocks. He took some of his young female workers with him and started a new company in Texcoco, called Botanica-Mex. He changed to *Dioscorea barbasco*, which gave a greater yield of diosgenin, and the price of progesterone dropped to \$10 a gram and later to \$5.

Marker's new company was allegedly harassed, legally and physically, by Syntex, and in 1946, it was sold to Gedeon Richter, which moved it to Mexico City and renamed it Hormosynth. Eventually, it came under the ownership of Organon of Holland, which still uses it under the name of Quimica Esteroides. By the 1960s, several

pharmaceutical companies were benefiting from the root-gathering operations in Mexico, closely regulated by the Mexican government that imposed annual quotas, about 43 thousand tons, to balance harvesting with the new annual growth. Mexican yams provided the starting material for the manufacture of oral contraceptives for about 15 years, giving way to other sources, such as soya beans, methods for total synthesis, or microbial fermentation.<sup>7</sup> In 1987, Marker was granted an honorary doctorate in science from the University of Maryland, the degree he failed to receive in 1926.

In 1990, Marker was planning on a quiet visit to Mexico to present a plaque made in his honor by Pennsylvania State University to Adolfina Moreno, the daughter of Alberto, the owner of the small country store whom Marker met in 1942. Mexican scientists and pharmaceutical people learned of the visit, and that summer, a chartered busload of 50 people retraced Marker's trip from Mexico City to Orizaba.<sup>6</sup> Marker rode in a car with Frederico Lehman's son, Pedro, who had become a distinguished chemist. When they reached the small store now owned by Adolfina, she tearfully thanked him and pointed to a nearby photo, her marriage picture from 50 years ago, with Marker in the wedding group. At the age of 92, Russell Earl Marker died in Wernersville, Pennsylvania, in 1995, from complications after a broken hip.

# The Race for Cortisone

When Marker left Syntex, he took his know-how with him. Fortunately for Syntex, there still was no patent on his discoveries. They invited George Rosenkranz, a Hungarian chemist stuck in Havana after the Pearl Harbor bombing, to take over Syntex's production of steroid hormones. Rosenkranz's task was complicated by Marker's secretiveness—he knew of Marker's published techniques but this was insufficient to replicate the process entirely. He found reagents labeled with code words; Marker's workers identified solvents by their weight and smell. Rosenkranz gave up on reconstructing Marker's process and worked out his own commercial manufacture of progesterone and testosterone from Mexican yams, and soon Syntex was making large profits providing the sex hormones as raw material to other pharmaceutical companies. Rosenkranz now had a large active laboratory that attracted a young chemist, Carl Djerassi. These men knew each other, meeting and interacting with each other at the Laurentian Hormone Conference, the annual meeting organized and directed by Gregory Pincus.

Carl Djerassi, aged 16, and his physician mother fled the Nazi Anschluss in Vienna and emigrated to the United States in 1939.<sup>8</sup> A Jewish refugee aid organization placed Djerassi with a family in Newark, New Jersey. He received a scholarship to Tarkio College in Tarkio, Missouri, and another scholarship from Kenyon College in Ohio, where he pursued chemistry. Djerassi received his graduate degree from the University of Wisconsin and then responded to an invitation to visit Syntex. Rosenkranz proposed that Djerassi head a research group to concentrate on the synthesis of cortisone, a position he accepted in 1949 at the age of 26.<sup>9</sup>

Synthetic cortisone was desirable because earlier in 1949, Philip S. Hench, a Mayo Clinic rheumatologist, showed a movie at a medical meeting documenting crippled arthritic patients before treatment and the same patients active, even dancing, after daily injections with cortisone.<sup>10</sup> Cortisone can be converted to the more active cortisol (also called hydrocortisone), the major product of the adrenal cortex, by hydroxylation, which converts the oxygen attached at the 11 position to a hydroxyl group by adding a hydrogen.

Hench had obtained the very expensive cortisone through a biochemist at the Mayo Foundation, Edward C. Kendall, who had isolated it from extracts of the adrenal cortex and from cattle bile. In 1950, Hench and Kendall were awarded the Nobel Prize in Physiology or Medicine. It was recognized that continuing regular treatment would be necessary, and the race was on to develop an easy and cheap method to synthesize cortisone and related drugs.

In Mexico City, Carl Djerassi was using the plant steroid diosgenin from the

Mexican yam as the starting point. In 2 year's time, Syntex achieved the partial synthesis of cortisone, reported in 1951.<sup>11</sup> The Syntex method never reached commercialization, however, because a more efficient process was developed by the Upjohn Company. However, Djerassi's laboratory produced Syntex's topical corticoid anti-inflammatory products, Synalar and Neo-Synalar. In 1959, Djerassi left Syntax and moved to head the chemistry department at Stanford University—a professorial position he held for the next 25 years.

The Upjohn Company and G.D. Searle & Company joined the competition to synthesize cortisone, with Upjohn, the bigger company, devoting over 150 scientists and technicians to the task. Upjohn leadership assigned a symbol to represent the project, a blowtorch, making it clear that this was a heated race they wished to win.<sup>12</sup> G.D. Searle was a smaller company, but its participation in this race would cement a long-term relationship with Gregory Pincus.

By 1949, Albert L. Raymond and the G.D. Searle company were supporting steroid research at the Worcester Foundation for Experimental Biology in Massachusetts, and Gregory Pincus, the cofounder of the Worcester Foundation, was a Searle consultant.<sup>13</sup> Oscar Hechter, a fellowship awardee at G.D. Searle, saw Hench's movie that year about the miraculous transformation of arthritic patients after being given cortisone and listened to his results. Hechter returned to the foundation and urged that his project be given top priority. Pincus and Oscar Hechter developed a perfusion method, pumping blood, serum, or a serum-like solution through fresh endocrine glands (adrenal glands, testicles, or ovaries) held in a glass apparatus and collecting the perfused fluid.<sup>14</sup> Using the enzymes in the glands, precursors in the perfusing fluid were converted to the final products, hydrocortisone or the sex steroids. This was a method that could be used to produce commercial amounts of cortisone products, and it was patented in 1946.<sup>15</sup>

However, the perfusion system was complicated. It required the development of methods to maintain the animal organs, a web of glassware to infuse and collect appropriate perfusing solutions, and the separation and identification of the steroid products. Responding to Pincus and Hechter's success, the Searle company constructed rows of perfusion systems in their Skokie plant. Each contained a periodically replaced fresh beef adrenal gland, producing every few hours a large volume of perfused solution. The long-term plan was to engineer a more economical and profitable system. But in the meantime, Searle was able to provide substantial amounts of cortisone to clinical researchers throughout the United States.

At the same time, Merck ramped up a synthesizing process from bile acids, and by the end of 1950, they were selling cortisone acetate to clinicians for a price that had been reduced from \$200 per gram to \$35. In Kalamazoo, Michigan, Upjohn chemists were pursuing a method based on the process used to make penicillin, conversion of

precursors by microbes to the desired product. The work was headed by Durey H. Peterson, the son of Swedish immigrants. Peterson believed that lower microorganisms might possess the same enzymes used by adrenal glands to make cortisone, especially the difficult step of introducing an oxygen molecule to the structure.

Using paper chromatography methods developed by Alejandro Zaffaroni, Peterson and H.C. Murray attacked the problem, beginning in 1949. First, they needed a microorganism. This they acquired, a fungus of the *Rhizopus* species, by leaving an agar plate on the window sill of a laboratory at the Upjohn Company. In 1 year's time, the two chemists proved the value of microorganisms in chemical synthesis. Their method used *Rhizopus nigricans* to convert progesterone to 11-hydroxyprogesterone, which could in turn be processed into hydrocortisone.

By 1955, Upjohn had become the market leader, and Searle shut down its perfusion cells and quit the race. Upjohn's commercialization of the methods developed by Peterson and Murray led to popular and successful products. But the Searle people had gained valuable experience that would eventually pay off with other synthesized hormones and products.

The Upjohn method used progesterone as the starting point, available in the early 1950s only from Syntex. George Rosenkranz's laboratory at Syntex was also pursuing the industrial synthesis of cortisone, and in July 1951, Syntex was about to sign a contract with a large chemical firm to begin production. This never happened because of a phone call. Rosenkranz told the story: "I received a phone call from Upjohn asking me whether we would be able to accept an order for ten tons of progesterone at forty-eight cents a gram."<sup>7</sup> The quantity was unheard of, and Upjohn's order remained a puzzle until the microfermentation method was published. Rosenkranz accepted the order, and Syntex found itself as the key supplier of progesterone to other companies.

# The Synthetic Progestational Drugs, Norethindrone and Norethynodrel

Djerassi and other Syntex chemists turned their attention to the sex steroids. They discovered that the removal of the 19-carbon from yam-derived progesterone increased the progestational activity of the molecule. The clue for this work came from Maximilian Ehrenstein at the University of Pennsylvania, who reported in 1944 that a potent progestational compound he had produced appeared to be progesterone without its carbon at the 19 position; henceforth the 19-nor family of compounds indicated steroid chemical structures without the carbon atom at the 19 position.<sup>16</sup> Chemists at Schering AG in Berlin had produced orally active versions of estradiol and testosterone in 1938, by substituting an acetylene group in the 17 position of the parent compounds. The resulting ethinyl estradiol later became the estrogen component in oral contraceptives. The ethinyl testosterone product was known as ethisterone, marketed in 1941, and the Syntex chemists reasoned that removal of the 19-carbon would increase the progestational potency of this orally active compound.

On October 15, 1951, norethindrone was synthesized at Syntex; the final steps were performed by Luis Miramontes, working on his undergraduate thesis in chemistry under Djerassi's supervision.<sup>9</sup> The patent application was filed 6 weeks later on November 22, 1951, and the work was presented in April 1952 at the annual meeting of the American Chemical Society and published in 1954.<sup>12</sup> The greater potency of norethindrone, achieved by removing the 19-carbon of ethinyl testosterone, compared with progesterone was demonstrated in monkeys and then four women at the National Institutes of Health, reported in 1953, 1956, and 1957.<sup>17,18,19</sup> Syntex supplied norethindrone to many investigators, including Gregory Pincus. Edward T. Tyler first reported its clinical use in 1955 for the treatment of menstrual disorders.<sup>20</sup>

Frank Colton, a chemist at G.D. Searle and Company, filed a patent for norethynodrel, a compound closely related to norethindrone, differing only in the position of the double bond, on August 31, 1953. The Polish-born Colton received his Ph.D. in chemistry from the University of Chicago. From 1949 to 1951, he was a research fellow working with Edward Kendall at the Mayo Foundation on the synthesis of cortisone. Colton joined Searle in 1951, along with Byron Riegel, to develop steroid drugs, succeeding with Nilevar, the first commercial anabolic agent marketed in 1956, and Aldactone, the antialdosterone antihypertensive agent introduced in 1959.

Norethynodrel was the result of a deliberate and planned program to create orally active agents with progestational activity. Later, Colton pointed out that although the Syntex and Searle chemists followed a similar path, they were independently pursuing

the trail blazed by previous scientists.<sup>13</sup> Along the way, hundreds of compounds were sent to Pincus at the Worcester Foundation to test for ovulation inhibition in rabbits. Their best drug, norethynodrel, assigned the number SC-4642, was synthesized at Searle in a process that was considered to be significantly different from the Syntex method.<sup>13</sup>

Djerassi urged legal proceedings for patent infringement, claiming that norethynodrel was converted to Syntex's compound, norethindrone, by gastric acid, but Parke-Davis, the American company licensing norethindrone, did not want to make waves presumably because Parke-Davis was supplying the antihistamine component of Searle's best-selling product for motion sickness, Dramamine.<sup>13</sup> Pincus would ultimately choose the Searle compound, norethynodrel for clinical testing as an oral contraceptive, and Syntex, not having marketing capability, licensed norethindrone to other pharmaceutical companies. Norethindrone was tested as a contraceptive by Edward Tyler in Los Angeles and Joseph Goldzieher in San Antonio, Texas, but Parke-Davis chose not to pursue government approval, probably fearing religious reactions. Subsequently, Syntex turned to the Ortho Division of Johnson & Johnson. By 1964, Ortho, Parke-Davis, and Syntex (now in California) were marketing oral contraceptives containing norethindrone or its acetate.

The creation of norethindrone and norethynodrel by the chemists was essential in the development of oral contraception because the natural hormone progesterone is relatively impotent given orally, requiring very large doses that even then do not achieve a uniform response. The synthetic progestational agents are very active when administered orally, producing reliable effects with small doses.

A Wall Street entrepreneur, Charles Allen, acquired Syntex in 1956 for \$2 million cash and a loan of \$2 million to be paid from future profits.<sup>7</sup> Rosenkranz became president and CEO, and Alejandro Zaffaroni, an Italian who emigrated from Montevideo, Uruguay, became executive vice president. Zaffaroni obtained his Ph.D. in 1949 in biochemistry from the University of Rochester, developing a paper chromatography system that soon became a principal method of studying steroid hormones.<sup>21</sup> Rosenkranz met Zaffaroni at the Laurentian Hormone Conference in 1951. Their aim was to develop a pharmaceutical company on a foundation of research. Rosenkranz said, "We were the brilliant amateurs with a 'can do anything' attitude. We were like stem cells (though then none of us really knew the concept). We could differentiate into anything we desired. Production, finance, sales, marketing—all held no fear for us."<sup>7</sup>

In 1961, the company moved to Palo Alto, California, influenced by their third partner, Djerassi, who was teaching at Stanford University. The growth of the company was meteoric, with blockbuster hits like Synalar, a topical corticosteroid for the treatment of psoriasis, and Naproxen, a nonsteroidal, anti-inflammatory drug. Much of

this success was to an innovative philosophy in the pharmaceutical business, “patent and publish.”<sup>7</sup> The Syntex scientists were encouraged to promptly publish their results, gaining the peer recognition that is such a motivating force for basic scientists. In 1994, Roche Holdings acquired Syntex for \$5.3 billion.



# Gregory Pincus

Gregory Goodwin (Goody) Pincus was born in 1903 in New Jersey, the son of Russian Jewish immigrants who lived on a farm colony founded by a Jewish philanthropic organization.<sup>15</sup> Pincus was the oldest of six children and grew up in a home of intellectual curiosity and energy, but even his family regarded him as a genius.

Pincus graduated from Cornell and went to Harvard to study genetics, joining Hudson Hoagland and B.F. Skinner as graduate students of W.J. Crozier in physiology, receiving degrees in 1927. Crozier taught Pincus, Hoagland, and Skinner (respectively, in reproductive biology, neurophysiology, and psychology) to apply science to human problems. This was to be the cornerstone of Pincus's own philosophy.

Pincus performed pioneering studies of meiotic maturation in mammalian oocytes, in both rabbit and humans. In 1934, Pincus reported the achievement of in vitro fertilization of rabbit eggs, earning him a headline in the **New York Times** that alluded to Haldane and Huxley. An article in **Colliers** depicted him as an evil scientist. By 1936, Harvard had cited Pincus's work as one of the university's outstanding scientific achievements of all time, but Harvard denied him reappointment in 1937.

At Clark University, Hudson Hoagland was the chair of the two-person biology department. Hoagland, upset and angry over Harvard's refusal to grant reappointment to his friend (suspecting that this was because of anti-Semitism), invited Pincus to join him. Hoagland secured funds for Pincus from philanthropists in New York City, enough for a laboratory and an assistant. This success impressed the two men, especially Hoagland, planting the idea that it would be possible to support research with private money.

Min-Chueh Chang was born in Tai Yuan, China, and in 1933, he earned a bachelor's degree in animal psychology from the Tsing Hua University in Peking and stayed at the university as a teacher. Chang won a national competition in 1938 that funded study abroad. He chose to study agricultural science at Edinburgh University. After 1 year, he was pleased to receive an invitation from Arthur Walton to study the physiology of sheep sperm at the University of Cambridge, and he promptly accepted. Chang received his Ph.D. in animal breeding under the direction of Walton and Sir John Hammond at the University of Cambridge in 1941. It was virtually impossible to leave England during the early years of World War II, and Chang continued to work at the university. In 1944, Chang planned to return to China, but first he wanted to spend a year in the United States. He wrote three letters to American scientists, and only Pincus answered, offering a fellowship at Clark University. Chang mistakenly assumed that a fellowship in the United States was the same as at the University of Cambridge where a fellow was assured of a lifetime income. The successful recruitment of M-C. Chang by Pincus was

to pay great dividends. Years later, Chang would direct the testing of new progestins to effectively inhibit ovulation in animals.

Soon Hoagland had put together a group of outstanding scientists, but because of his ongoing antagonism with the president of Clark University, the group was denied faculty status. Working in a converted barn, they were totally supported by private funds. By 1943, 12 of Clark's 60 faculty were in the Department of Biology.

Frustrated by the politics of academia, Hoagland and Pincus had a vision of a private research center devoted to their philosophy of applied science. Indeed, the establishment of the Worcester Foundation for Experimental Biology, in 1944, can be attributed directly to Hoagland and Pincus, their friendship for each other, and their confidence, enthusiasm, ambition, and drive. It was their spirit that turned many members of Worcester society into financial supporters of biologic science.

Although named the Worcester Foundation for Experimental Biology, the Foundation was located in the summer of 1945 across Lake Quinsigamond in a house on an estate in Shrewsbury. From 1945 to the death of Pincus in 1967, the staff grew from 12 to 350 (scientists and support people), 36 of whom were independently funded and 45 were postdoctoral fellows. The annual budget grew from \$100,000 to \$4.5 million. One hundred acres of adjoining land were acquired, and the campus grew to 11 buildings. In its first 25 years, approximately 3,000 scientific papers were published.

But in those early years, Pincus was the animal keeper, Mrs. Hoagland was the bookkeeper, M-C. Chang was the night watchman, and Hoagland mowed the lawn. During the years of World War II, Pincus and Hoagland combined their interests in hormones and neurophysiology to focus on stress and fatigue in industry and the military.

Katharine Dexter McCormick (1875–1967) was a trained biologist, an early suffragist, and wealthy from both inheritance and marriage. She was the second woman to graduate from the Massachusetts Institute of Technology. Her intervention with money, energy, incisive thinking, and persistent dedication was instrumental in the development of oral contraception. Katharine's husband suffered from schizophrenia, and she established the Neuroendocrine Research Foundation at Harvard to study schizophrenia. This brought her together with Hoagland, who told her of the work being done by Chang and Pincus who were seeking orally active progestins to inhibit ovulation.

Pincus attributed his interest in contraception to his growing appreciation for the world's population problem and to a 1951 visit in New York with Margaret Sanger, at that time president of the Planned Parenthood Federation of America. Sanger promised a small amount of money and expressed hope that a method of contraception could be derived from the laboratory work being done by Pincus and Chang. During this meeting, Pincus formulated his thoughts derived from his mammalian research. He envisioned a progestational agent in pill form as a contraceptive, acting like progesterone in

pregnancy.

Margaret Sanger brought Pincus and Katharine McCormick together. On June 7, 1953, 78-year-old Katharine met with 50-year-old Pincus at the Worcester Foundation and wrote him a check for \$20,000. A week later, Pincus and Hoagland met with Katharine and her lawyer. They signed a contract outlining the goals, the decision-making process, and the timetable. Pincus received a second check for \$20,000, and Katharine agreed to fund laboratory improvements, which ended up as the completion of a new building in 1955.

Katharine's contract with the Worcester Foundation stipulated that Pincus would provide written reports every 2 weeks. In addition, Pincus and John Rock, the Boston gynecologist performing the initial oral contraceptive studies in his patients, made many visits to Katharine's home office on Beacon Street across the street from the Harvard Club. Katharine had Sara De Laney, her secretary, take careful notes in shorthand, and at the next visit, De Laney read the transcribed notes to her boss so that she would be prepared. Periodically the principals met at the Worcester Foundation. Katharine peppered Pincus, Chang, and Rock with questions and urged them to stop wasting time. She found Pincus "imaginative and inspirational; Rock was informative and very realistic about medical work." By now, everyone was familiar with Katharine's methods. She had earned their respect, and detailed reports on laboratory results, clinical planning, and budgets were immediately forthcoming. Time and time again, Katharine proved that she handled delays poorly, but she approached each meeting with an eagerness that slowly but surely was rewarded with success after 7 years and an expenditure of about \$2 million of Katharine's money.

In her last years, Katharine continued to support the work of Pincus and Chang. When testing the hundreds of compounds that yielded the progestational agents in birth control pills, Chang observed that some of them prevented implantation of fertilized eggs in rabbits. From 1962 to 1966, Chang and Pincus were pursuing a drug that could prevent pregnancy with one administration, a day or two after sexual intercourse. With Pincus's death, this project was abandoned. It is not certain whether Chang and Pincus coined the phrase the "morning after" pill, but it is accurate to state that the concept came from Chang.

When Pincus and Chang began their studies, the focus was on inhibition of ovulation, first by progesterone and then by synthetic progestins. Chang's contribution was easy to overlook. Chang worked away in his laboratory, and it was Pincus who was highly visible, raising the money and providing direction. Chang started by repeating the experiments reported by Makepeace in 1927, documenting that progesterone could inhibit ovulation. The first experiment was on April 25, 1951, and Chang quickly moved to testing the newly synthesized progestins from Searle and Syntex.

By December 1953, three synthetic progestins were selected as the most potent and effective in inhibiting ovulation: norethindrone from Syntex, and Searle's norethynodrel and norethandrolone. The animal and human results were published in **Science** in 1956.<sup>22,23</sup> In 1957, these three compounds were approved for the treatment of menstrual disorders with the trade names of Norlutin, Enovid, and Nilevar, respectively.

It was Pincus who made the decision to involve a physician because he knew human experiments would be necessary. John Rock, chief of gynecology and obstetrics at Harvard, met Pincus at a scientific conference and discovered their mutual interest in reproductive physiology. Rock and his colleagues pursued Pincus's work. Using oocytes from oophorectomies, they reported in vitro fertilization in 1944, the first demonstration of fertilization of human oocytes in vitro. Rock was interested in the work with progestational agents, not for contraception, however, but because he hoped the female sex steroids could be used to overcome infertility.

In their first collaborative study, Pincus and Rock administered oral progesterone, 300 mg/day. Pincus suggested a 20-day regimen beginning on day 5 of the menstrual cycle.<sup>24</sup> He had two reasons for choosing this regimen: (1) it covered the time period during which nearly all, if not all, ovulations occurred and (2) the withdrawal menstrual bleed at the conclusion of the treatment period would mimic the timing of a normal menstrual cycle and reassure the women that they were not pregnant. The first study involved 33 volunteers who ovulated regularly but had been infertile for 2 years. The women were treated for 1–3 cycles after a baseline control month. About 85% of the treated women did not ovulate during the treatment cycles. Not one became pregnant during treatment, pleasing Pincus who all along was aiming for contraception, and four became pregnant after treatment, pleasing Rock who initially was motivated by his pursuit of the “rebound” phenomenon for the treatment of infertility.

Sanger and McCormick needed some convincing that Rock's Catholicism would not be a handicap, but they were eventually won over because of his stature. Rock was a physician who literally transformed his personal values in response to his recognition of the problems secondary to uncontrolled reproduction. With the help of Luigi Mastroianni, the first administration of synthetic progestins to women was to Rock's patients in 1954. Of the first 50 patients to receive 10–40 mg of synthetic progestin (a dose extrapolated from the animal data) for 20 days each month, all failed to ovulate during treatment (causing Pincus to begin referring to the medication as “the pill”), and 7 of the 50 became pregnant after discontinuing the medication, again pleasing Rock, who all along was motivated to treat his infertile patients.

In 1956, with Celso-Ramon Garcia and Edris Rice-Wray, working in Puerto Rico, the first human trial was performed. The initial progestin products were contaminated with about 1% mestranol. In the amounts being used, this added up to 50–500 µg of

mestranol, a sufficient amount of estrogen to inhibit ovulation by itself. When efforts to provide a more pure progestin lowered the estrogen content and yielded breakthrough bleeding, it was decided to retain the estrogen for cycle control, thus establishing the principle of the combined estrogen-progestin oral contraceptive. Early clinical trials were also conducted by J.W. Goldzieher in San Antonio and E.T. Tyler in Los Angeles.

Pincus, a longtime consultant to Searle, picked the Searle compound for extended use and, with great effort, convinced Searle that the commercial potential of an oral contraceptive warranted the risk of possible negative public reaction. Pincus also convinced Rock, and together they pushed the U.S. Food and Drug Administration (FDA) for acceptance of oral contraception. In 1957, Enovid was approved for the treatment of miscarriages and menstrual disorders and, on June 23, 1960, for contraception. Neither Pincus nor the Worcester Foundation got rich on the pill; alas, there was no royalty agreement.

The pill did bring Pincus fame and travel. There is no doubt that he was very much aware of the accomplishment and its implications. As he traveled and lectured in 1957, he said: “How a few precious facts obscurely come to in the laboratory may resonate into the lives of men everywhere, bring order to disorder, hope to the hopeless, life to the dying. That this is the magic and mystery of our time is sometimes grasped and often missed, but to expound it is inevitable.”<sup>25</sup>

Pincus was the perfect person to bring oral contraception into the public world, at a time when contraception was a private, suppressed subject. Difficult projects require people like Pincus. A scientific entrepreneur, he could plow through distractions. He could be hard and aggressive with his staff. He could remain focused. He hated to lose, even in meaningless games with his children. Yet he combined a gracious, warm, charming manner with his competitive hardness. He was filled with the kind of self-confidence that permits an individual to forge ahead, to translate vision into reality. Pincus died in 1967 (as did Katharine McCormick at the age of 92), of myeloid metaplasia. Rock died in 1984, at the age of 94. Chang died in 1991 at the age of 82 and was buried in Shrewsbury, near his laboratory and close to the grave of Pincus.

Syntex, a wholesale drug supplier, was without marketing experience or organization. By the time Syntex had secured arrangements with Ortho for a sales outlet, Searle marketed Enovid in 1960 (150 g mestranol and 9.85 mg norethynodrel). Ortho-Novum, using norethindrone from Syntex, appeared in 1962. Wyeth Laboratories introduced norgestrel in 1968, the same year in which the first reliable prospective studies were initiated. It was not until the late 1970s that a dose-response relationship between problems and the amount of steroids in the pill was appreciated. Health care providers and patients, over the years, have been confronted by a bewildering array of different products and formulations. In reality, there are few, if any, meaningful,

clinically important distinctions between preparations. The practitioner should use the lowest dose that provides effective contraception.

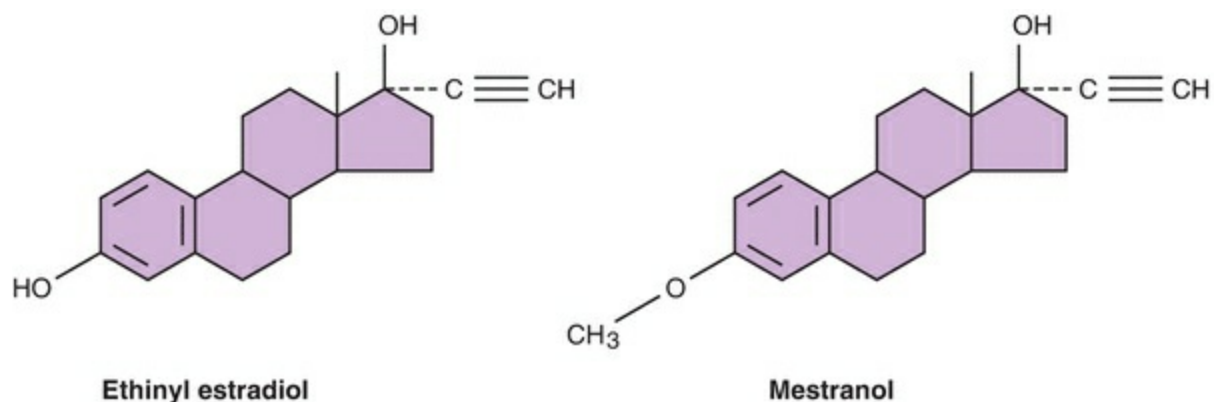
# PHARMACOLOGY OF STEROID CONTRACEPTION

---

# The Estrogen Component of Combination Oral Contraceptives

Estradiol is the most potent natural estrogen and is the major estrogen secreted by the ovaries. The major obstacle to the use of sex steroids for contraception was reduced activity of the compounds when given orally. As described above, a major breakthrough occurred in 1938 when it was discovered that the addition of an ethinyl group at the 17 position increased oral activity. Ethinyl estradiol is a very potent oral estrogen and is the form of estrogen in most oral contraceptives. Another estrogen, present in older products and actually a precursor to the metabolically active ethinyl estradiol, was the 3-methyl ether of ethinyl estradiol, mestranol.

Mestranol and ethinyl estradiol are different from natural estradiol and must be regarded as pharmacologic drugs ([Figure 22.1](#)). In the human body, differences in potency between ethinyl estradiol and mestranol do not appear to be significant, certainly not as great as indicated by assays in rodents. This is now a minor point because, with the exception of contraceptives with estradiol valerate or estradiol, all of the low-dose oral contraceptives contain ethinyl estradiol ([Figure 22.1](#)). Estradiol valerate is an esterified form of estradiol, allowing oral administration with significant potency. The ester is rapidly hydrolyzed to estradiol. Combinations of several progestins with estradiol valerate have demonstrated good contraceptive efficacy.



**FIGURE 22.1**

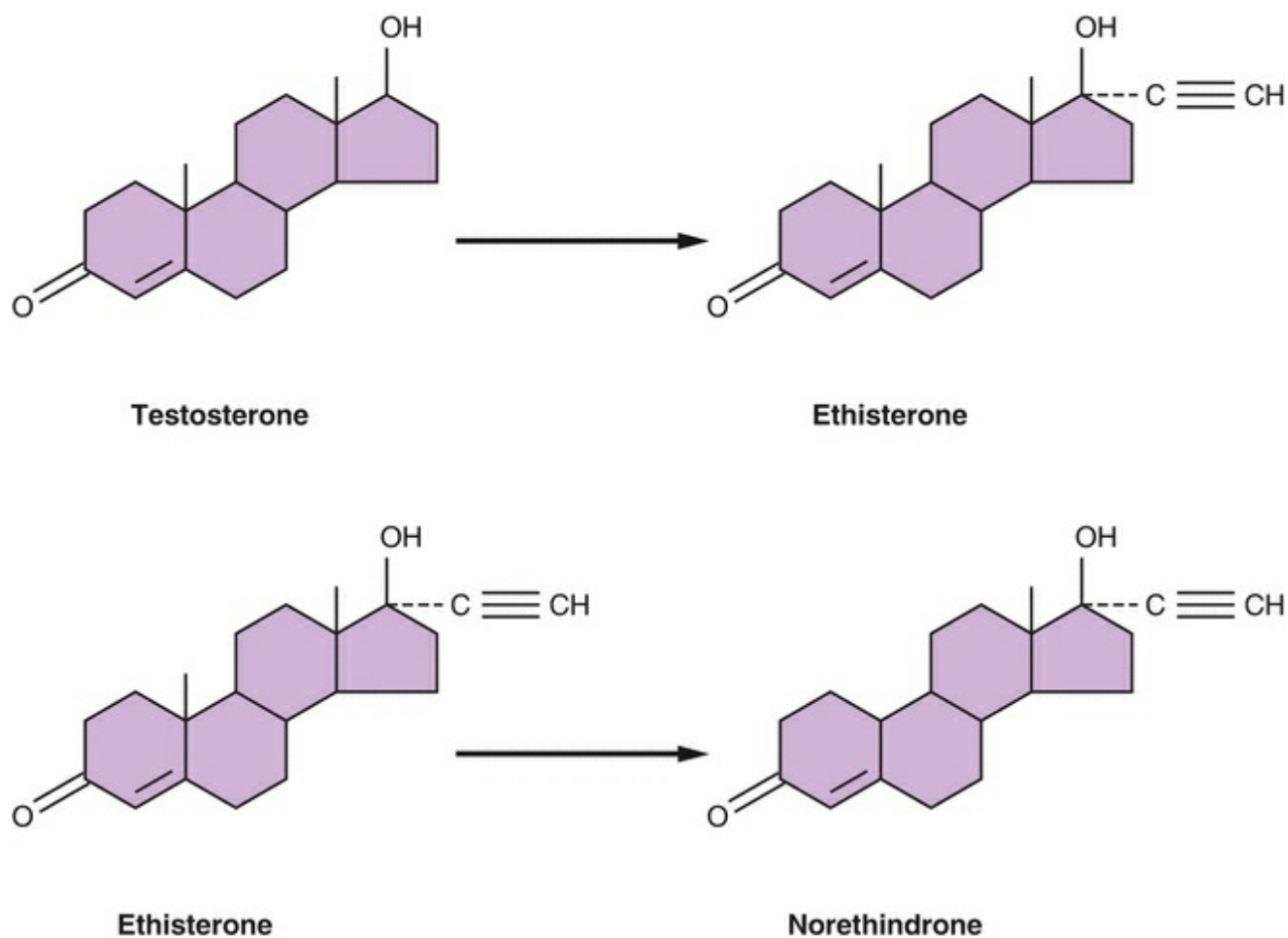
The metabolism of ethinyl estradiol (particularly as reflected in blood levels) varies significantly from individual to individual and from one population to another.<sup>26,27</sup> There is even a range of variability at different sampling times within the same individual. Therefore, it is not surprising that the same dose can cause side effects in one individual and not in another.



The estrogen content (dosage) of the pill is of major clinical importance and has been tied to risk of thrombosis and, therefore, increased risk of death (in the past with high doses). The principal role of the estrogens in oral contraceptives is to augment the contraceptive efficacy of the progestin and stabilize the endometrium, thereby reducing breakthrough bleeding. The lowest dose of estrogen that prevents bleeding is preferred.

# The Progestin Component of Combination Oral Contraceptives

The discovery of ethinyl substitution and oral potency led (at the end of the 1930s) to the preparation of ethisterone, an orally active derivative of testosterone (Figure 22.2). In 1951, it was demonstrated that removal of the 19-carbon from ethisterone to form norethindrone did not destroy the oral activity, and most importantly, it changed the major hormonal effect from that of an androgen to that of a progestational agent (Figure 22.2). Accordingly, the progestational derivatives of testosterone were designated as 19-nortestosterones (denoting the missing 19-carbon). The androgenic properties of these compounds, however, were not totally eliminated, and minimal anabolic and androgenic potential remains within the structure.

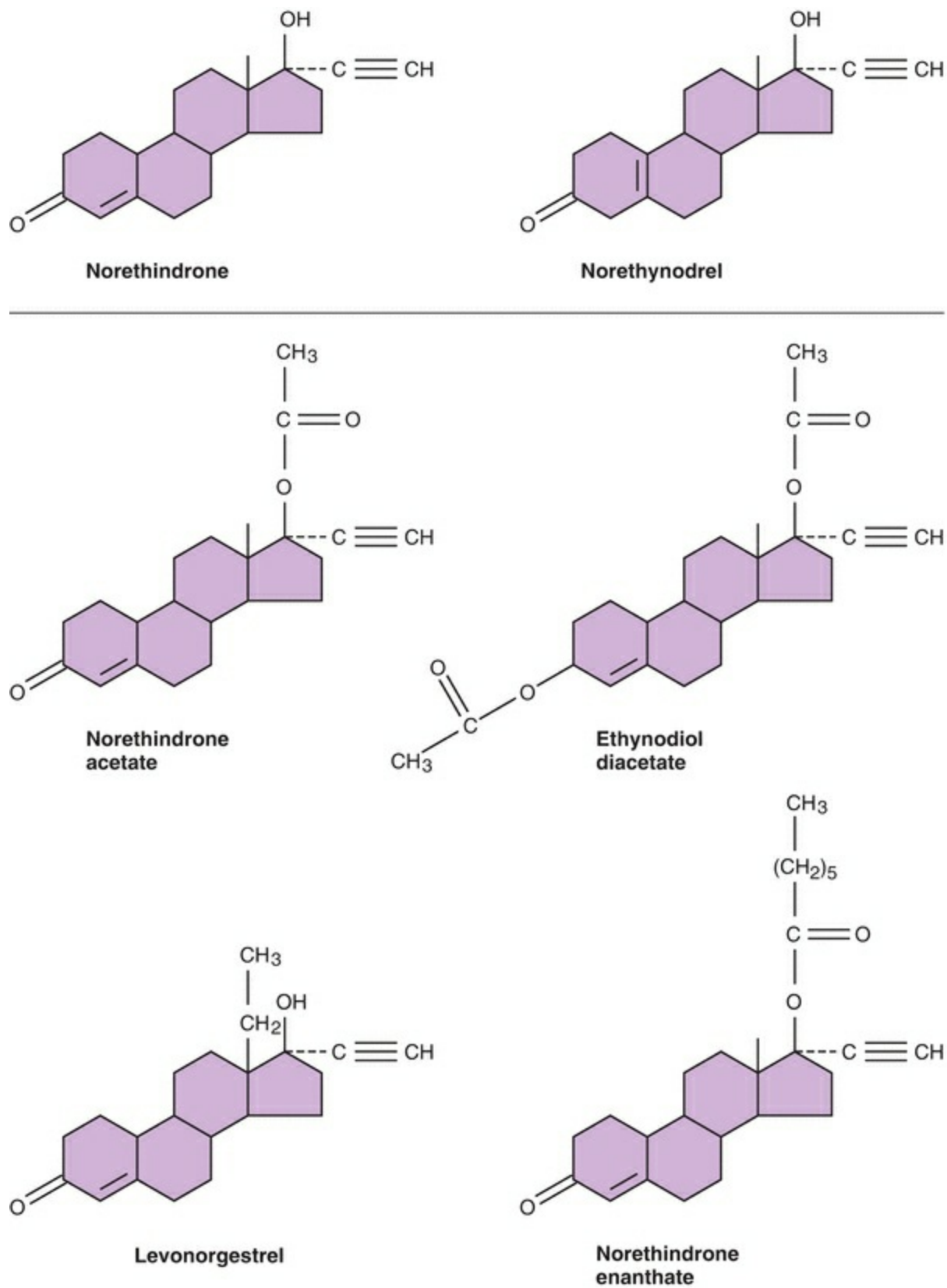


**FIGURE 22.2**

The “impurity” of 19-nortestosterone, that is, androgenic as well as progestational

effects, was further complicated in the past by a belief that they were metabolized within the body to estrogenic compounds. Studies indicate that norethindrone can be converted to ethinyl estradiol; however, the rate of this conversion is so low that insignificant amounts of ethinyl estradiol can be found in the circulation or urine following the administration of the commonly used doses of norethindrone in premenopausal women.<sup>28</sup> In animal and human studies, however, only norethindrone, norethynodrel, and ethynodiol diacetate have estrogen activity, and it is very slight due to weak binding to the estrogen receptor.<sup>29</sup> Clinically, androgenic and estrogenic activities of the progestin component are insignificant due to the low dosage in the current oral contraceptives.

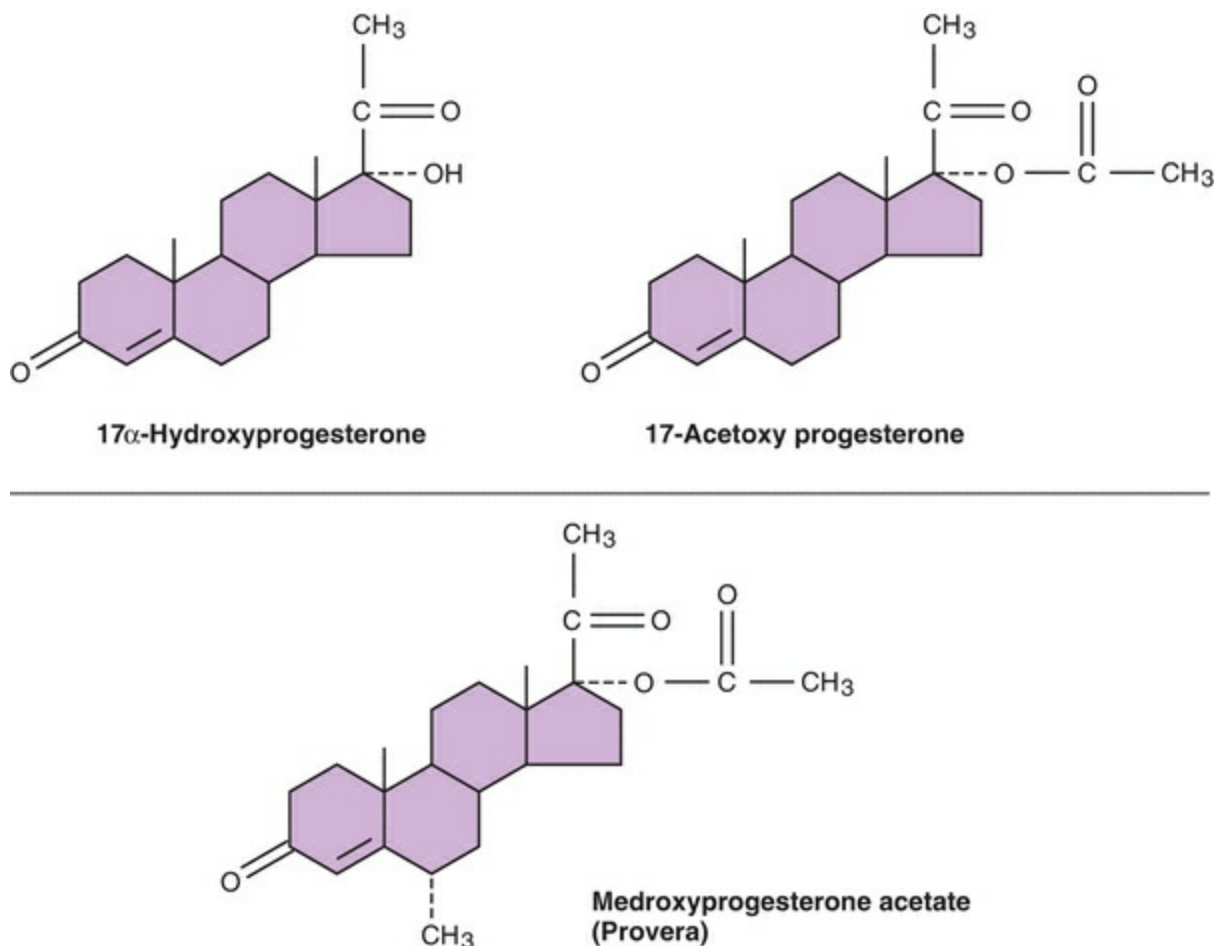
The norethindrone family contains the following 19-nortestosterone progestins: norethindrone, norethynodrel, norethindrone acetate, ethynodiol diacetate, lynestrenol, norgestrel, norgestimate, desogestrel, and gestodene (**Figure 22.3**).



**FIGURE 22.3**

A second group of progestins became available for use when it was discovered that

acetylation of the 17-hydroxy group of 17-hydroxyprogesterone produced an orally active but weak progestin. An addition at the 6 position is necessary to give sufficient progestational strength for human use, probably by inhibiting metabolism. Derivatives of progesterone with substituents at the 17 and 6 positions include the widely used medroxyprogesterone acetate (Figure 22.4). Chlormadinone and cyproterone acetate are progesterone derivatives with a 17 $\alpha$ -acetoxy group, marketed in a combination with ethinyl estradiol.



**FIGURE 22.4**

Most of the progestins closely related to norethindrone are converted to the parent compound. Thus, the activity of norethynodrel, norethindrone acetate, ethynodiol diacetate, and lynestrenol is due to rapid conversion to norethindrone.

Norgestrel is a racemic equal mixture of the dextrorotatory enantiomer and the levorotatory enantiomer. These enantiomers are mirror images of each other and rotate the plane of polarized light in opposite directions. The dextrorotatory form is known as D-norgestrel, and the levorotatory form is L-norgestrel (known as levonorgestrel).

Levonorgestrel is the active isomer of norgestrel.

Desogestrel undergoes two metabolic steps before the progestational activity is expressed in its active metabolite, 3-keto-desogestrel, known as etonogestrel. This metabolite differs from levonorgestrel only by a methylene group in the 11 position. Gestodene differs from levonorgestrel by the presence of a double bond between carbons 15 and 16; thus, it is  $\Delta$ -15 gestodene. It is metabolized into many derivatives with progestational activity, but not levonorgestrel. Several metabolites have the potential to contribute to the activity of norgestimate, a third-generation progestin.<sup>30,31</sup> Almost all of the biologic effects are attributed to the 17-deacetylated metabolite, now known as norelgestromin; the levonorgestrel metabolites are tightly bound to sex hormone-binding globulin (SHBG) (unlike norelgestromin) severely limiting their biologic activity.<sup>32</sup>

### **Definitions Used in Epidemiologic Studies**

**Low-Dose Oral Contraceptives—Products containing less than 50- $\mu$ g ethinyl estradiol**

**First-Generation Progestins—Products containing estranes derived from testosterone such as norethindrone, norethynodrel, norethindrone acetate, and ethynodiol diacetate and pregnanes derived from 17-OH progesterone such as medroxyprogesterone acetate and chlormadinone acetate**

**Second-Generation Progestins—Products containing gonanes derived from testosterone such as levonorgestrel and norgestrel**

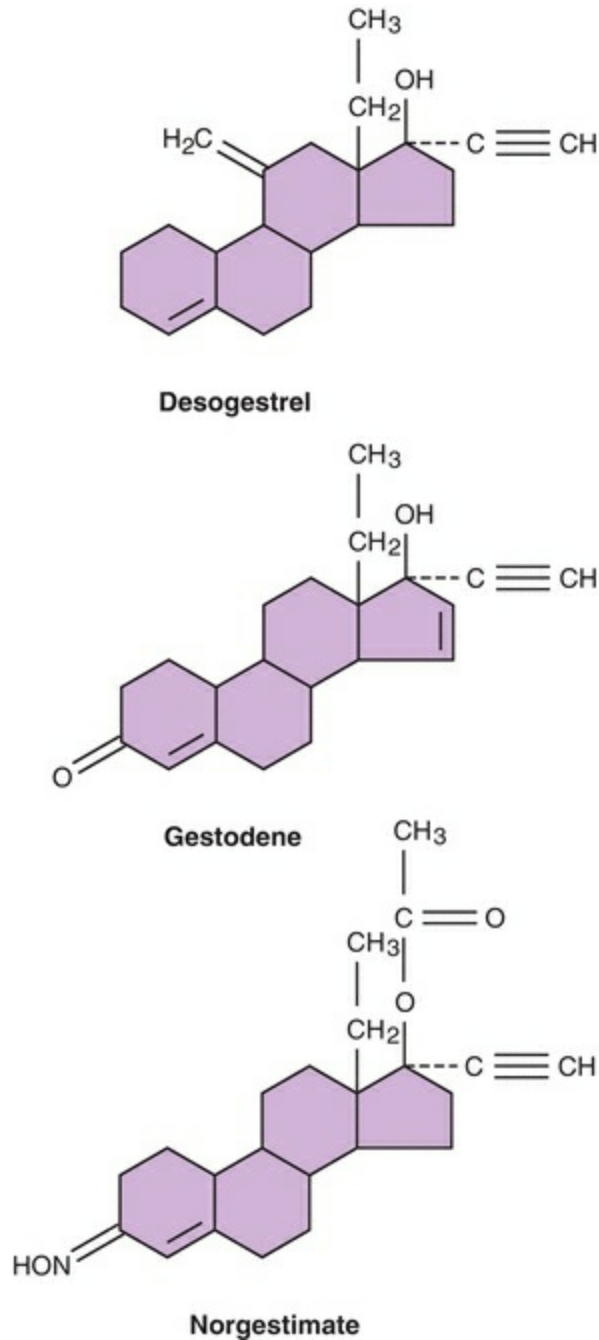
**Third-Generation Progestins—Products containing desogestrel, gestodene, norgestimate/norelgestromin, and etonogestrel**

**Fourth-Generation Progestins—Products containing nonethylated estranes such as drospirenone and dienogest, or pregnanes (19-norprogesterones) such as Nestorone, nomegestrol acetate, and trimegestone**

Probably the greatest influence on the effort that yielded the new progestins was the belief throughout the 1980s that androgenic metabolic effects were important, especially in terms of cardiovascular disease. Cardiovascular side effects are now known to be due to a dose-related stimulation of thrombosis by estrogen and not secondary to metabolic effects such as lipid changes. In the search to find compounds that minimize androgenic effects, however, the pharmaceutical companies succeeded.

The new progestins include desogestrel, gestodene, and norgestimate (**Figure 22.5**).<sup>33</sup> In regard to cycle control (breakthrough bleeding and amenorrhea), the new

formulations are comparable with previous low-dose products. All progestins derived from 19-nortestosterone have the potential to decrease glucose tolerance and increase insulin resistance. The impact on carbohydrate metabolism of the previous low-dose formulations was very minimal, and the impact of the new progestins is negligible. Most changes are not statistically significant, and when they are, they are so subtle as to be of no clinical significance. The decreased androgenicity of the progestins in the newer products is reflected in increased SHBG and decreased free testosterone concentrations to a greater degree than the older oral contraceptives. This difference could be of greater clinical value in the treatment of acne and hirsutism, especially when using fourth-generation progestins.<sup>34,35</sup>

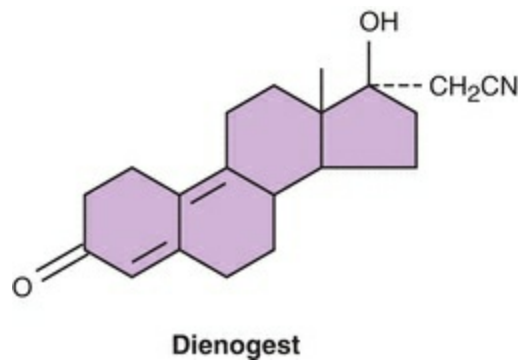


**FIGURE 22.5**

The new progestins, because of their reduced androgenicity, predictably do not adversely affect the cholesterol-lipoprotein profile. Indeed, the estrogen-progestin balance of combined oral contraceptives containing one of the new progestins even promotes favorable lipid changes. Thus, the new formulations have the potential to offer protection against cardiovascular disease, an important consideration as we enter an era of women using oral contraceptives for longer durations and later in life. But one must be cautious regarding the clinical significance of subtle changes, and it is unlikely that there will be a major impact.

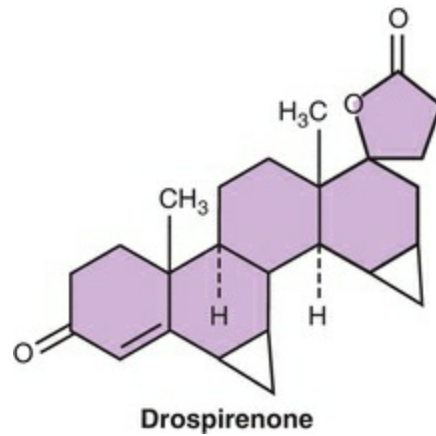


Dienogest is a 19-nortestosterone that has a cyanomethyl group instead of an ethinyl group in the 17 position and an additional double bond, combining the properties of both the 19-nortestosterone family and the derivatives of progesterone (**Figure 22.6**).<sup>36</sup> It exerts antiandrogenic activity and is used in a 2-mg dose combined with 30 µg ethinyl estradiol or estradiol valerate as an oral contraceptive.<sup>37,38,39</sup> The combination oral contraceptive with estradiol valerate (Qlaira, Natazia) uniquely consists of four phases, with the estradiol valerate dose decreasing from 3 mg to 1 mg over 26 days, and dienogest provided in a dose of 2 mg on days 3–7 and 3 mg on days 8–24. This phasic administration of estradiol valerate and dienogest provides ovulation inhibition and a bleeding profile comparable to that of a standard, low-dose, monophasic oral contraceptive.<sup>38,39,40</sup>



**FIGURE 22.6**

Drospirenone is a progestin that is an analog of spironolactone (**Figure 22.7**). Its biochemical profile is very similar to progesterone, including a high affinity for the mineralocorticoid receptor that produces an antimineralocorticoid effect.<sup>41,42</sup> Contraceptive efficacy equal to that of other formulations is achieved in the combination of 3.0 mg drospirenone and 30 µg ethinyl estradiol (Yasmin). Because drospirenone is spironolactone-like with antiandrogenic and antimineralocorticoid activity, caution is recommended in regard to serum potassium levels, avoiding its use in women with abnormal renal, adrenal, or hepatic function. However, hyperkalemia and its complications have not been a clinical problem encountered with the use of a drospirenone-containing contraceptive in the general population.<sup>43</sup>



**FIGURE 22.7**

It has been suggested that the oral contraceptive that contains drospirenone is effective for treating premenstrual syndrome/premenstrual dysphoric disorder (PMDD). Earlier studies were done without placebo comparison. We have learned over the last decade that treatments for premenstrual syndrome must be studied in comparison with a placebo because of the powerful placebo response associated with this disorder. In a double-blind, placebo-controlled randomized trial, 82 women with established diagnoses of PMDD were assessed using the Calendar of Premenstrual Experiences scale.<sup>44</sup> A statistically significant reduction associated with Yasmin treatment was achieved in only one category, that measuring acne, appetite, and food cravings. The overall result was essentially not significant. Further, many oral contraceptives would likely have achieved similar results if directly compared.

In a multicenter 2-year study in Europe of 900 women, Yasmin was compared to Marvelon (the same dose of ethinyl estradiol and 150  $\mu\text{g}$  desogestrel).<sup>45</sup> Marvelon was associated with a small increase in body weight after the fifth cycle; the average body weight associated with Yasmin remained throughout the 2 years below the baseline level at the beginning of the study but increased to a level above the baseline at the end of the study. The early weight loss amounted to only 1% of body weight and may reflect diuretic action. This study also observed a small reduction in premenstrual symptoms with Yasmin. The evidence, therefore, for a beneficial impact on PMDD with Yasmin is minimal.

The 24-day version of this oral contraceptive, Yaz (3 mg drospirenone and 20  $\mu\text{g}$  ethinyl estradiol), demonstrated in a 3-month multicenter, double-blind, randomized trial symptomatic improvement in 450 women with PMDD.<sup>46</sup> The magnitude of the treatment response compared with placebo amounted to a need to treat eight women to achieve at least a 50% reduction in symptom severity in a single patient. **These results suggest that modest beneficial results in treating PMDD may be achieved with any**

**oral estrogen-progestin contraceptive administered in an extended regimen. We would expect similar results with the daily, continuous administration of any oral contraceptive.**

Nomegestrol acetate (NomAc), derived from progesterone with the elimination of the 19-carbon, is used in Europe in postmenopausal hormone therapy and recently combined with estradiol for contraception. The first 24 pills of a package contain 2.5 mg NomAc and 1.5 mg estradiol, and the last four are placebos in an extended regimen typical of newer oral contraceptives. NomAc has potent inhibitory effects on gonadotropin secretion, and no androgenic activity (in fact, it is somewhat antiandrogenic).<sup>47</sup> Unlike drospirenone, NomAc has no glucocorticoid or mineralocorticoid activity.<sup>48</sup> Its relative lack of endometrial effects has been associated with an increase in irregular bleeding in some clinical trials.

# Different Oral Formulations

The multiphasic preparation alters the dosage of both the estrogen and progestin components periodically throughout the pill-taking schedule. The aim of these new formulations is to alter steroid levels in an effort to achieve lesser metabolic effects and minimize the occurrence of breakthrough bleeding and amenorrhea, while maintaining efficacy. However, metabolic studies with the multiphasic preparations indicate no differences or very slight improvements over the metabolic effects of low-dose monophasic products.

An estrophasic approach (Estrostep) combines a continuous low dose of a progestin with a low but gradually increasing dose of estrogen.<sup>49</sup> This approach minimizes estrogen exposure at the beginning of the cycle, yielding a low rate of side effects such as nausea. The increasing estrogen results in a marked increase in SHBG that produces a very low androgenic state by reducing the bioavailability of circulating free androgens, and this formulation is very effective for treating acne.<sup>50,51</sup>

## Extended Regimens

Two clinical concerns prompted the development of an oral contraceptive regimen with a reduction in the pill-free interval: (1) breakthrough bleeding and (2) ovarian activity during pill taking that could lead to ovulation and failure of contraception. Extending the active pill cycle by several days is aimed at decreasing breakthrough bleeding and spotting and reducing the length of withdrawal bleeding without compromising efficacy or safety and perhaps increasing contraceptive protection by a greater suppression of ovarian activity. This strategy has produced several new 24-day products: Loestrin 24 Fe (1 mg norethindrone acetate/20 µg ethinyl estradiol with 4 iron-containing placebo pills), Yaz (3 mg drospirenone/20 µg ethinyl estradiol), and Minesse (60 µg gestodene/15 µg ethinyl estradiol).

The traditional combination oral contraceptive pill, consisting of estrogen and progestin components, is given daily for 3 of every 4 weeks, for a total of 21 days. Despite multiple contraceptive actions, there has been concern that the current lower-dose products allow follicular development in some individuals, especially in those who metabolize and clear steroid hormones rapidly.<sup>52</sup> Even with greater follicular activity with the lowest-dose oral contraceptives, ovulation is still effectively prevented in most women.<sup>53</sup> Nevertheless, recognition of follicular growth emerging during the standard pill-free interval with oral contraceptives and awareness that ovarian activity is greater with the lowest-dose estrogen formulations, along with the problem of breakthrough bleeding, provided the motivation to shorten the pill-free interval.

A move to low doses of estrogen in combined oral contraceptives has been fueled by a desire to minimize estrogen-linked, serious cardiovascular side effects. Breakthrough bleeding rates are higher with the lower-dose (20 µg ethinyl estradiol) oral contraceptives, although not dramatically.<sup>54,55,56</sup> Breakthrough bleeding is higher in women who smoke and in smokers who use formulations with 20 µg ethinyl estradiol.<sup>57</sup> Breakthrough bleeding gives rise to fears and concerns; it is aggravating and even embarrassing. These are reasons why although breakthrough bleeding during oral contraceptive use is considered a **minor** side effect, it can have a **major** consequence: interruption of adherence to therapy resulting in unwanted pregnancies. A nationwide survey identified irregular bleeding as the primary reason for discontinuation of oral contraception.<sup>58</sup> It is important to emphasize that there is no evidence that the onset of bleeding is associated with decreased efficacy, no matter what oral contraceptive formulation is used, even the lower-dose products. Indeed, in a careful study, breakthrough bleeding did not indicate decreases in the contraceptive blood levels of the estrogen and progestin components.<sup>59</sup>

The most frequently encountered breakthrough bleeding occurs in the first few months of use as the endometrium adjusts to the pharmacologic impact of the oral contraceptive. The incidence is greatest in the first 3 months, ranging from 10% to 30% in the first month to less than 10% in the third. However, the differences among the various 21-day formulations containing 20 µg ethinyl estradiol are of minimal clinical significance. For this reason, the new approach evolved, increasing the number of days with active drug treatment to 24.

Ovarian follicles begin to grow during the 7-day pill-free interval in traditional regimens of oral contraceptives because follicle-stimulating hormone (FSH) levels begin to rise after 4 pill-free days.<sup>60</sup> These follicles can reach impressive size; ovarian follicles more than 10 mm in diameter have the potential to continue growth as a dominant follicle.<sup>61</sup> The successful conversion to a dominant follicle marks the “selection” of a follicle destined to ovulate, the process whereby, with rare exception, only a single follicle succeeds.<sup>62,63</sup> However, follicles that reach sizes consistent with dominant follicles, even preovulatory follicles, are not assured of ovulation in women using oral contraceptives in a compliant fashion. Some stop growing, while others continue to grow but fail to ovulate, almost assuredly because of suppression of the luteinizing hormone (LH) surge.<sup>64,65,66</sup> Nevertheless, evidence indicates that dominant follicles can emerge, secrete preovulatory levels of estradiol, and ovulate, and in this case, contraceptive efficacy requires the other progestational actions.<sup>53,66,67</sup>

## Clinical Studies with Extended Regimens

The major clinical study with Loestrin 24 Fe was a 6-month, open-label, randomized, active-controlled study in 32 centers in the United States.<sup>68</sup> Nine hundred and thirty-eight patients were randomized to either the 24-day product or the 21-day formulation (1 mg norethindrone acetate/20 µg ethinyl estradiol) in a 4:1 ratio that yielded 705 women in the treated group and 181 in the comparison group available for analysis. A strength of this study was that it compared the 24-day product to an identical 21-day formulation. The study was not powered to determine a significant difference in efficacy comparing the two products. The Pearl Index for the 24-day schedule was 1.82 (1.78 for subjects 35 years old and younger). The cumulative pregnancy rate for 6 months was 0.9%. These numbers are typical for all oral contraceptives.

The number of days with breakthrough bleeding or spotting was comparable in both groups, but the 24-day group demonstrated a steady decline in breakthrough bleeding/spotting days, so that in cycle 6 the mean number of bleeding days was significantly lower in the 24-day group (0.95 vs. 1.63). Among the women in the 24-day group, those who switched from another oral contraceptive had a lower mean number of bleeding days compared to new users, probably reflecting suppression of endometrial growth by the previous use. Each cycle with the 24-day product demonstrated a shorter duration of withdrawal bleeding (bleeding beginning after the last day of active drug intake), achieving statistical significance in the second cycle. Combining breakthrough bleeding and withdrawal bleeding, the total number of days over the entire 6 treatment cycles with bleeding was significantly less in the 24-day group: 18.6 for the 24-day schedule compared with 23.2 for the 21-day regimen.

A reasonable concern with extending the days of active treatment is the resulting increase in overall hormone exposure. The accumulative dosages over 6 cycles, however, were not notably different. The 24-day schedule totaled 144 mg of norethindrone acetate and 2.88 mg ethinyl estradiol, compared with 126 mg norethindrone acetate and 2.52 mg ethinyl estradiol in the 21-day group. There were no demonstrable differences in adverse events.

A 21-day product has been compared with extending the schedule to 23 days, using 75 µg gestodene/20 µg ethinyl estradiol.<sup>69,70,71</sup> The 23-day regimen produced a greater suppression of ovarian activity as measured by lower estradiol levels and less follicular activity as assessed by ultrasonography; however, the incidence of bleeding and spotting days was similar in the two treatment groups. The 23-day regimen was associated with shorter withdrawal bleeding periods compared with the 21-day schedule.

Ovarian activity was compared in a group of women using 60 µg gestodene/15 µg

ethinyl estradiol for 24 days compared to a group using the same product on the standard 21-day regimen.<sup>72</sup> The women using the 21-day regimen experienced greater follicular activity with larger follicles and higher estradiol levels. Breakthrough bleeding was more prevalent with the 24-day schedule; however, the number of treatment cycles in this small study was not large enough to assess bleeding control. A larger study compared the 24-day regimen of 60 µg gestodene/15 µg ethinyl estradiol with a 21-day regimen using 150 µg desogestrel/20 µg ethinyl estradiol and reported a greater incidence of breakthrough bleeding with the 24-day regimen; however, the length of bleeding was shorter and the intensity of bleeding was reduced.<sup>73</sup> The 1-year overall incidence of breakthrough bleeding with this 24-day, 15-µg ethinyl estradiol product has been reported to be 19.3%.<sup>74</sup>

In a short study of only three treatment cycles, the 24-day 3-µg drospirenone/20-µg ethinyl estradiol product was compared to a 21-day regimen of the same formulation.<sup>75</sup> The 24-day schedule was associated with greater follicular suppression and only one ovulation in cycle 3 compared with four ovulations in the 21-day regimen when the initial 3 tablets in the 3rd month were substituted with placebos. A study of 12 women using this formulation for either 23 days or 24 days documented greater suppression of FSH, LH, inhibin B, and estradiol during the pill-free interval when compared to women using the same product for 21 days.<sup>60</sup>



# Clinical Recommendation

The 24-day regimen of low-dose oral contraceptives achieves its goals. Both bleeding and ovarian activity are reduced. Indeed, the two are related. **Diminished ovarian follicular activity is responsible for less fluctuation in endogenous estrogen levels, resulting in a more quiescent and stable endometrium.** Extended (and continuous dosing) regimens compared with the standard 21-day regimen are associated with a decrease in menstrual discomfort, headaches, and bloating.<sup>76,77,78</sup>

Another clinical advantage of the 24-day regimen is a reduction in the risk of “escape” follicular activity if a patient inadvertently starts a new package 1 or 2 days late. Randomized studies that extended the pill-free interval by 2 or 3 days observed that women taking a 20- $\mu$ g ethinyl estradiol formulation had a greater increase in follicular activity compared with women using a 35- $\mu$ g ethinyl estradiol product.<sup>79,80</sup> Ovarian follicular activity is greater with products containing 20  $\mu$ g ethinyl estradiol, and the maximal follicular size reached is larger. In one study, a greater proportion of women on a 20- $\mu$ g product, around 30%, achieved follicular diameters of 15 mm or greater, compared with a 35- $\mu$ g formulation when the pill-free interval was extended from 7 to 9 days.<sup>80</sup> Once follicles achieve a diameter greater than 10 mm, an increasing percentage goes on to ovulate even in the presence of oral contraceptive treatment.<sup>81</sup> The lower-dose formulations produce less suppression of gonadotropin secretion, documented in these studies by higher FSH, LH, and estradiol blood levels among the users of the 20- $\mu$ g ethinyl estradiol product.

Not only does the 24-day product allow a day or two grace period, but the extended hormone exposure suppresses gonadotropin and follicular activity to a greater degree. Thus, even in patients with good compliance, a greater reduction in follicular activity can reduce the possibility of breakthrough ovulations and contraceptive failure. This would be difficult and expensive to document because it would require a clinical trial with a very large number of patients.

A regimen is available that supplies a package containing the number of pills required for 84 days of daily administration, a reduction of menstrual frequency to 4 per year.<sup>82</sup> This approach includes Seasonale (20  $\mu$ g ethinyl estradiol and 100  $\mu$ g levonorgestrel), with 7 placebo pills after 84 active pills, and Seasonique, with 7 pills of 10  $\mu$ g ethinyl estradiol after 84 active pills. The combination with 7 days of estrogen was a response to the discovery that 84 active pill days are rapidly followed by a rise in FSH with stimulation of follicular growth.<sup>83</sup> A slighter higher rate of breakthrough bleeding with this regimen improves with time, but overall, bleeding is less with Seasonique because of better FSH suppression.<sup>84,85</sup>

**Steroid contraception in the currently used low doses has been demonstrated to be very safe for healthy women. Efforts to improve steroid contraception are now focusing on maximizing adherence to treatment and minimizing pregnancies from contraceptive failures. The 24-day regimen offers clinicians and patients the important advantage of reduced bleeding and the possible advantage of greater efficacy because of better compliance as well as a reduction in ovarian activity.**

## Continuous Dosing

More and more women are embracing the idea that fewer menstrual periods provide a welcome relief from bleeding and menstrual symptoms. Clinicians for years have prescribed unlimited daily oral contraceptives to treat conditions such as endometriosis, bleeding disorders, menstrual seizures, and menstrual migraine headaches, even to avoid bleeding in athletes and busy individuals. Many women do not require the periodic experience of vaginal bleeding to assure themselves they are not pregnant. And of course, modern society is long past the notion that menstrual bleeding is a cleansing event, a detoxification. It is not necessary for women using oral contraceptives to experience any withdrawal bleeding. Monthly bleeding, periodic bleeding, or no bleeding—this is an individual woman's choice. Any combination oral contraceptive can be used on a daily basis; even the lowest-estrogen dose formulations provide excellent bleeding and side effect profiles in a continuous regimen.<sup>77,86,87,88</sup> **Oral contraceptives with the lowest doses of estrogen should be used for overweight and older women, but progestin-only methods are an even better choice.**

Eliminating a pill-free interval also reduces symptoms associated with menstruation, such as headaches, dysmenorrhea, and bloating.<sup>89,90,91</sup> As with the extended regimen, continuous dosing provides greater ovarian suppression, reducing the potential for breakthrough and escape ovulations.<sup>92</sup> A further benefit of continuous use is simplification of the pill-taking schedule with the potential of better compliance and a lower failure rate. Continuous dosing can also be achieved with the contraceptive vaginal ring and the contraceptive patch. The return of ovulation and achievement of pregnancy are not delayed after discontinuation of continuous dosing.<sup>92,93</sup>

# Generic Products

Generic products are therapeutically equivalent drugs, containing the same amount of active ingredients in the same concentration and dosage form. These products are less expensive, marketed by pharmaceutical companies after patent expiration of the original drug. Generic oral contraceptives need only meet the test of bioequivalence; studies to demonstrate efficacy, side effects, and safety are not required. Meeting the test of bioequivalence requires demonstration in a small number of subjects that absorption, concentrations, and time curves are comparable to the reference drug. The generic product will be approved if the bioequivalence testing ranges from 80% to 125% of the values for the reference drug (differences no greater than 20% lower or 25% higher). Approved, patented products must not vary more than  $\pm 10\%$ ; therefore, a generic oral contraceptive could contain only 70% of the standard dose. In the lowest-dose oral contraceptives, this could impair efficacy. However, we should hasten to point out that there has been no evidence or even anecdotal suggestions that generic oral contraceptives have reduced efficacy or cause more side effects such as breakthrough bleeding. Patients should be forewarned that generic products differ in shape, packaging, and color.

# VAGINAL ESTROGEN-PROGESTIN CONTRACEPTION

---

The vagina provides an ideal site for contraceptive steroid absorption. The stratified squamous epithelium, unlike the skin, is not cornified, permitting easier steroid penetration to the underlying lamina propria, made of collagen and elastin, which is richly vascularized. A muscular layer under the epithelium has smooth muscle fibers running in both circular and longitudinal directions. The final layer of areolar connective tissue contains a second vascular plexus. There are no fat cells, glands (secretions are transudates, not glandular), or hair follicles to interfere with drug absorption.<sup>94</sup>

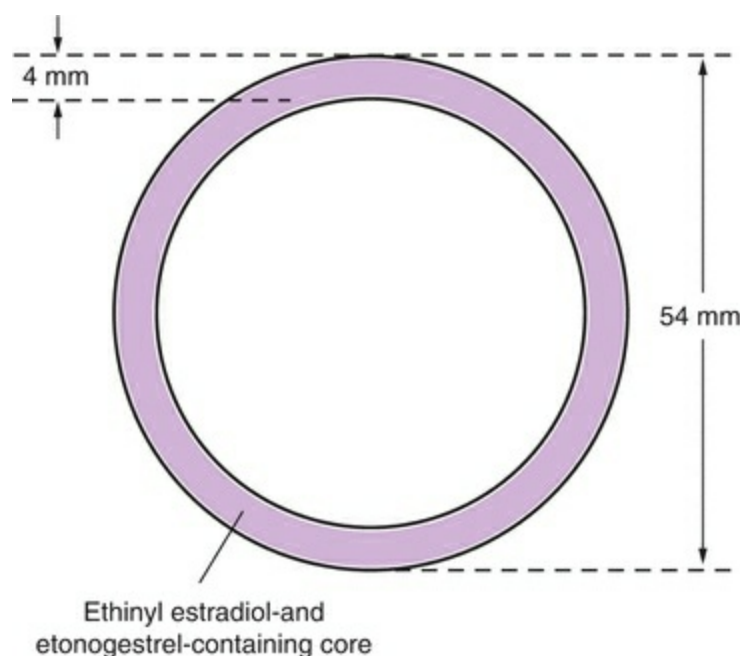
Like subcutaneous, intramuscular, transdermal, and intrauterine contraceptive methods, the vaginal route avoids gastrointestinal absorption and the first-pass liver effect. Absorption from the gastrointestinal tract can be unpredictable and may be compromised by vomiting, drug-drug interference, or decreased intestinal absorption capacity. The gastrointestinal lumen and the liver are sites of elimination for many compounds, and avoidance of the first-pass effect is particularly advantageous for compounds that undergo a high degree of hepatic metabolism; orally administered natural estrogens, for example, are 95% metabolized by the liver. Oral administration results in marked fluctuations of contraceptive steroid serum concentrations that may lead to side effects like irregular bleeding and nausea. These daily changes are lower with vaginal than with oral or transdermal administration and lowest with implant and intrauterine methods.<sup>95,96</sup>

Six progestin-only and seven different estrogen-progestin combined vaginal contraceptive rings have been designed to provide 1 week to 1 year of contraception with weaker progestins like progesterone and medroxyprogesterone in short-acting rings (1 week) and more potent levonorgestrel and Nestorone in long-acting ones (up to a year). The “NuvaRing” vaginal combined steroid contraceptive is available in the United States, and the Federal Drug Administration has approved “Annovera,” which will be available starting in 2019 or 2020. They are both flexible, soft, transparent rings. “NuvaRing” is made of ethylene vinyl acetate copolymer in which are contained crystals of etonogestrel and ethinyl estradiol. This ring is covered with a 2- $\mu$ m-thick membrane of ethylene vinyl acetate. The ring is available in only one size, 4 mm in thickness and 54 mm in diameter (smaller than a diaphragm), that fits all women. “Annovera” is a silicone elastomer 56 mm in diameter and 8.4 mm in thickness, with two 3-mm cores, one of which secretes segesterone acetate and one of which secretes segesterone acetate and ethinyl estradiol. “Annovera” can provide contraception for up to 1 year.<sup>96,97,98</sup>

Rings that contain only progesterone or Nestorone are being developed for use in breast-feeding women.

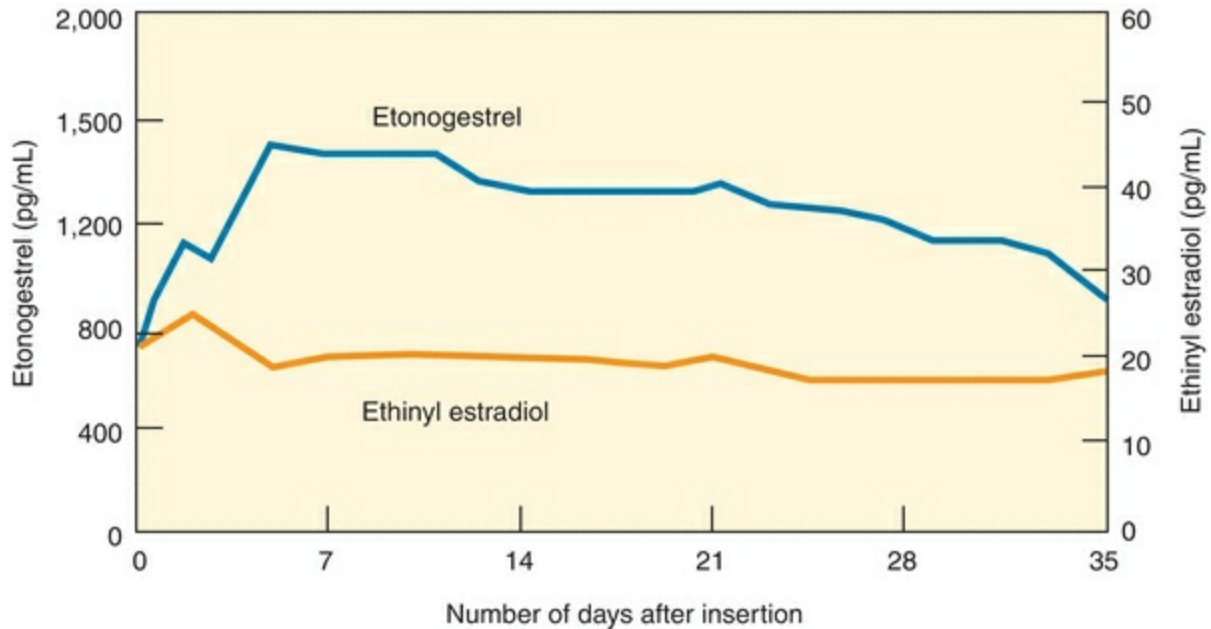
# The Vaginal Ring Method

The use of vaginal contraception in the United States has steadily increased since its introduction, and it is now one of the more popular methods. An important advantage of vaginal steroid contraception is an improvement in compliance achieved by the elimination of a daily regimen of treatment. The NuvaRing releases 15 mg ethinyl estradiol and 120 mg etonogestrel/day.<sup>99</sup> Because the progestin and estrogen are mixed in the ethylene vinyl acetate core, in the unlikely event of damage to the ring, leakage or higher release of the hormones does not occur. Circulating estrogen and progestin levels reach target concentrations within 24 hours. The circulating estrogen levels reach a maximum level after 2–3 days; etonogestrel reaches maximum level after 7 days and remains stable for 35 days.<sup>100</sup> **The ring is inserted by the patient and worn for 3 weeks. The vaginal ring can be initiated in the same fashion as oral contraceptives, on the first day of menses, a Sunday start, or an immediate, same-day start. Routine use requires the insertion of a new ring every 4 weeks to allow for withdrawal bleeding, but an acceptable and easier method is to insert a new ring on the first of every month. Continuous use is an appropriate option.<sup>100</sup> Because the ring contains enough steroid hormone to inhibit ovulation for at least a total of 5 weeks,<sup>101</sup> when used continuously, a new ring can be inserted every 5 weeks. Breakthrough bleeding with continuous use is effectively managed by a 4-day hormone-free interval<sup>102</sup> (Figure 22.8).**



**FIGURE 22.8**

The NuvaRing produces circulating progestin and estrogen levels that are only 40% and 30%, respectively, of the **peak** levels associated with an oral contraceptive containing 150 mg desogestrel and 30 mg ethinyl estradiol (**Figure 22.9**).<sup>95</sup> These levels effectively inhibit ovulation, providing pregnancy rates of less than 1% in clinical trials.<sup>99,101,103,104</sup> **If the vaginal ring is removed and not replaced within 3 hours, the manufacturer recommends backup contraception until the ring has been in place for 7 days.**



**FIGURE 22.9**

Annovera releases 0.15 mg/day of segesterone acetate and 0.013 mg/day of ethinyl estradiol when placed vaginally for up to 21 days at a time. It is then removed and stored for 7 days before being replaced. Annovera can be used for 13 cycles. Circulating estrogen and progestin levels reach a maximum at 2 hours after insertion with the initial cycle, with average circulating levels of segesterone acetate ranging from 94 to 191 pg/mL depending on the cycle number and average circulating levels of ethinyl estradiol ranging from 19 to 44 pg/mL depending on the cycle number. Similarly to the NuvaRing, Annovera can be started with menses, Sunday start, or immediately. If started immediately or switching from a different contraceptive method, the manufacturer recommends backup contraception for 7 days.<sup>98</sup> Currently, women with body mass indices greater than 29 kg/m<sup>2</sup> are excluded from using Annovera due to potential higher risk of venous thromboembolic disease in this group in clinical trials.

Taking into account bioavailability as influenced by protein binding, systemic



exposure to etonogestrel is similar comparing the vaginal ring to an oral contraceptive containing 150 mg desogestrel; however, the systemic exposure to ethinyl estradiol is about 50% of that of an oral contraceptive containing 30 mg ethinyl estradiol.<sup>95</sup> Vaginal administration is associated with the lowest estrogen exposure as measured by “area under the curve,” compared with oral and transdermal methods.<sup>101</sup> This may explain the low incidence of estrogen-related side effects such as dysmenorrhea, nausea, and breast tenderness.<sup>95,99,102</sup> Breakthrough bleeding and spotting rates are lower (around 6%) when compared with an oral contraceptive containing 30 mg of ethinyl estradiol and much lower than with 15- or 20-mg pills.<sup>99,103,104</sup> Bleeding and spotting occur more frequently with extended or continuous regimens.<sup>96</sup>

It is not necessary to place the vaginal ring in a specific position; it need only be in contact with vaginal mucosa and need not surround the cervix. The vaginal ring is intended to be placed in a normal vagina; infections and anatomic abnormalities are reasons for clinicians and patients to consider other methods. The most common reasons for discontinuation (about 2–4% in the clinical trials) have been vaginal discomfort, unwanted awareness of the ring’s presence, coital problems, or expulsion (during a year of use about 2–3% of women experience spontaneous expulsion). Women report that the ring is easy to insert and remove, and, although about 15% of women and 30% of partners report feeling the ring during intercourse, this is not a common reason for discontinuation.<sup>99,105</sup> **Removal for sexual intercourse is not recommended, but efficacy is maintained if the ring is replaced within 3 hours.** Postmarketing surveillance studies documented a high rate of satisfaction with good cycle control.<sup>106,107</sup>

# TRANSDERMAL ESTROGEN-PROGESTIN CONTRACEPTION

Transdermal contraceptive dosing, like vaginal dosing, increases compliance as it does not need to be remembered daily. The transdermal contraceptive patch (Ortho Evra) has an area of 20 cm<sup>2</sup> (4.5 cm × 4.5 cm) and three layers in a matrix-type arrangement. The backing outer polyester layer provides support for the middle layer that contains the adhesive and the hormones, and the inner layer is a polyester liner that is removed from the adhesive layer just before application. The size is that required to deliver an effective dose of the steroid hormones. The patch contains 750 mg ethinyl estradiol and 6 mg of norelgestromin and delivers 20 mg ethinyl estradiol and 150 mg norelgestromin each day when applied to discrete locations on the lower abdomen, upper outer arm, the buttock, or the upper torso (excluding the breast) (Figure 22.10). Norelgestromin is the primary active metabolite of orally administered norgestimate and was previously known as 17-deacetylnorgestimate. Norelgestromin still undergoes liver metabolism with transdermal application; however, the resulting metabolite, levonorgestrel, is highly bound to SHBG, limiting its biologic impact. About 97% of norelgestromin is bound to albumin, and 3% is unbound.<sup>32</sup>

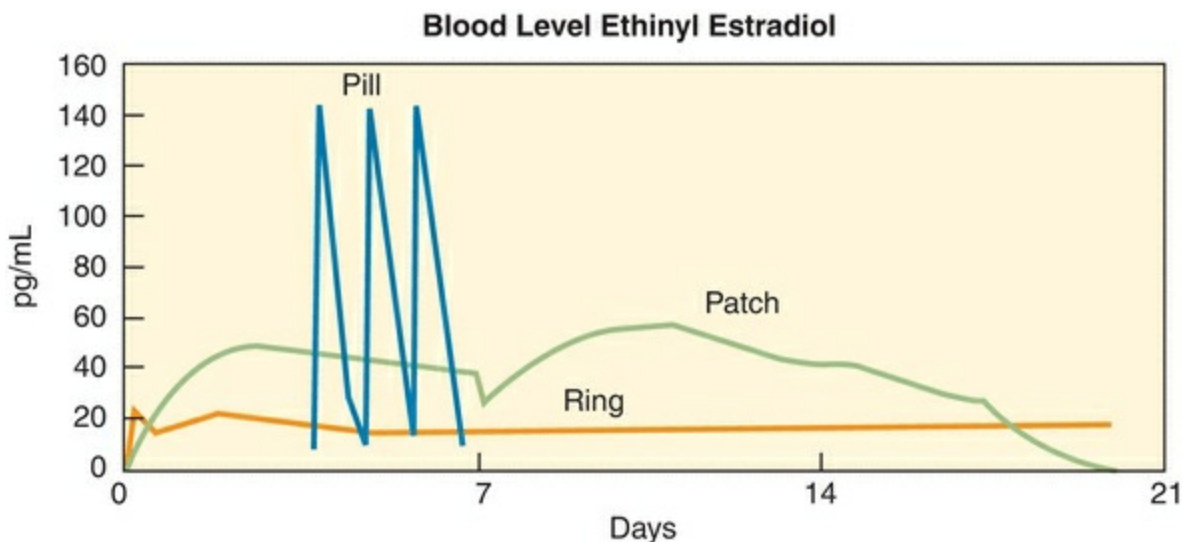


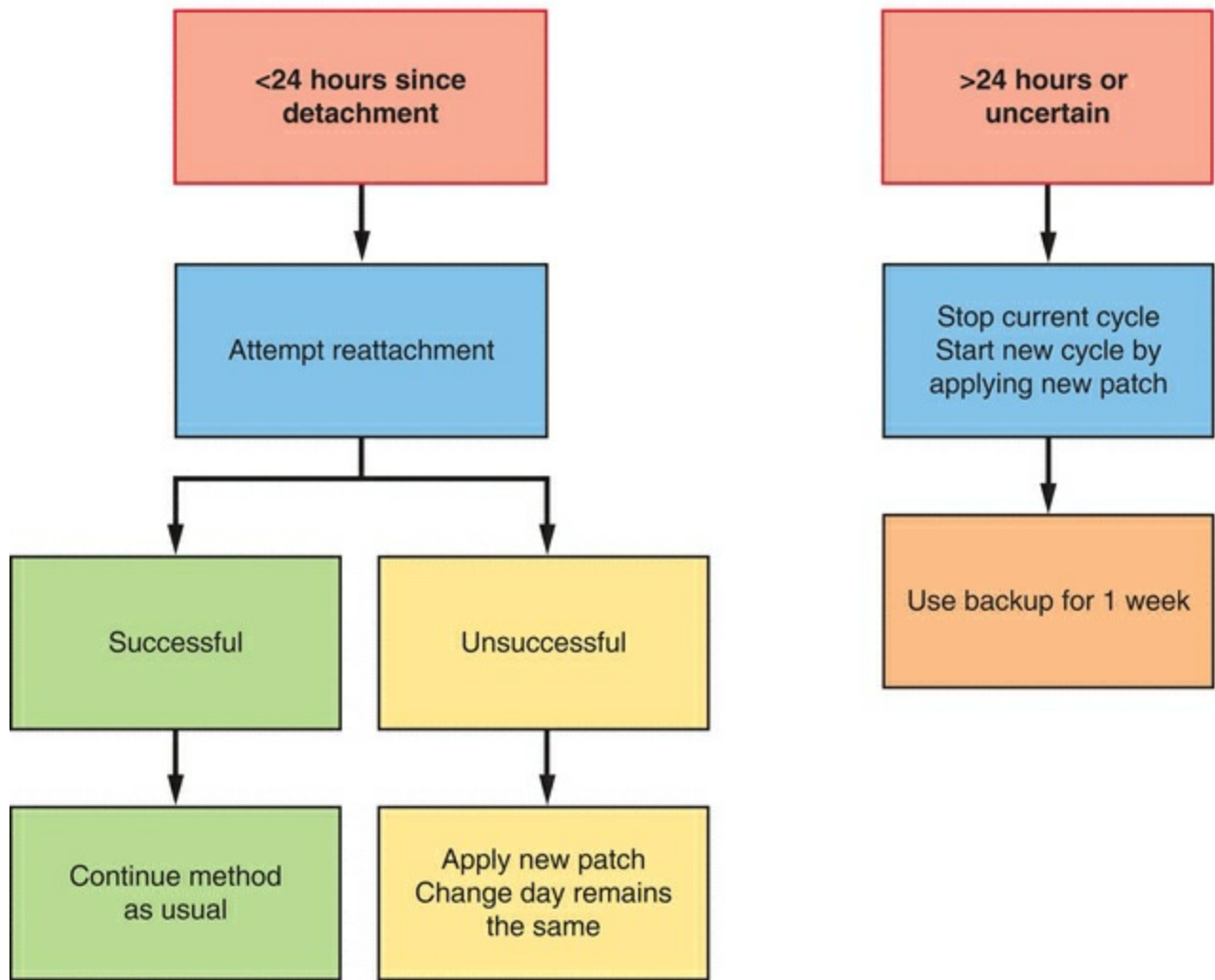
FIGURE 22.10

# The Transdermal Method

The patch is applied on the same day, but not on the exact same site, once each week for 3 weeks, followed by a week without use of the patch. **As with oral contraceptives, patient and clinician may choose to use the contraceptive patch continuously, eliminating withdrawal bleeding.** Timing on the day of application need not be precise; the patch is very forgiving. Instructions for first-day starts, Sunday starts, or immediate same-day starts of oral contraception are also recommended for the patch (backup contraception for 7 days unless the starting day is also day 1 of the menstrual period). Application should be chosen with care to avoid contact with tight clothing, and pressure should be applied for at least 10 seconds, making sure that the edges stick. The skin should be clear, clean, and dry and free of irritation or creams and lotions. The patches are stored in their protective pouches at room temperature. **Many women are bothered by the lint ring that forms around the edges of transdermal patches. In our experience, this problem can be eliminated by lightly dusting talcum powder (“baby” powder) around the edges after application. If a ring does form, it is easily removed with mineral oil.**

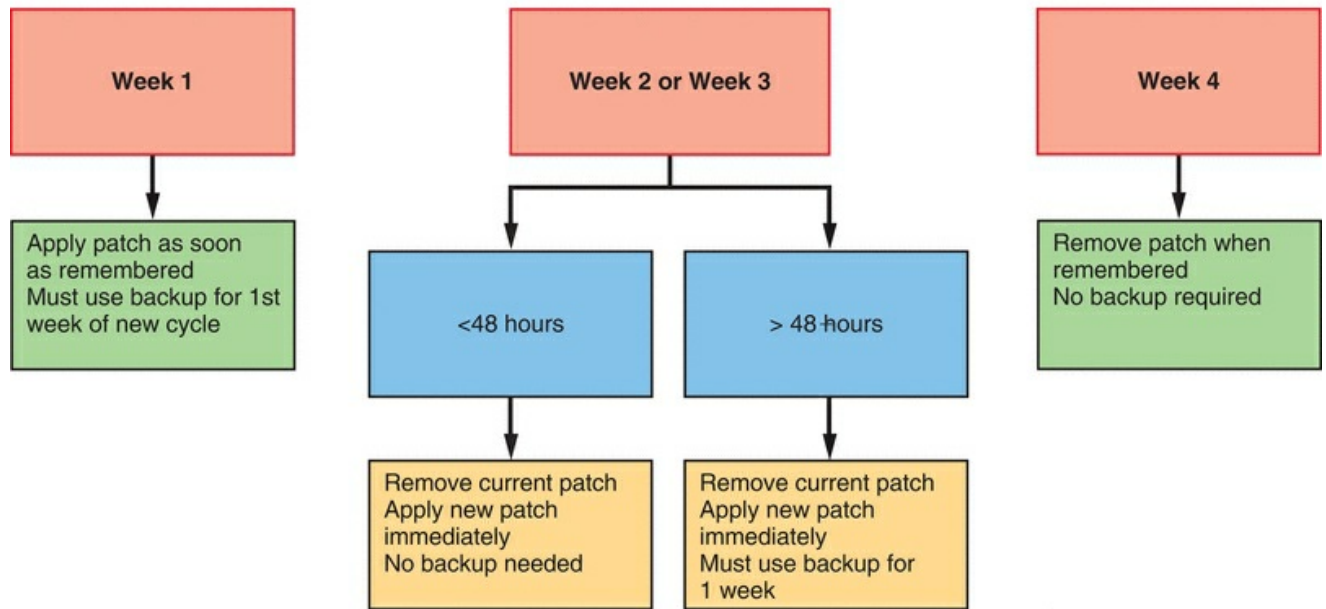
Detachment occurs with about 5% of patches, and about half occur in cycle 1 with inexperienced patients.<sup>108,109</sup> In studies of at least a year’s duration, about 2–5% of patches were replaced.<sup>110,111</sup> Use of the patch requires common sense; anything other than a secure adhesion deserves a conservative approach. If the patch seems loose or has been partially or totally off for less than 24 hours, the same patch can be reapplied or replaced with a new patch (the patch change day remains the same). Single extra patches are provided for this (**Figures 22.11 and 22.12**) purpose by pharmacies and clinics if the clinician writes a separate prescription for an extra patch along with the regular prescription. If the patch has been detached for more than 24 hours, a new patch is applied initiating a new cycle and new change day (backup contraception for 7 days is recommended). Delay of a new patch cycle requires a new start with the usual 7-day backup. **A delay within the patch cycle of no more than 2 days has no risk and does not change the cycle, but a delay more than 2 days also requires the initiation of a new cycle and change day with backup.** However, in a study that compared three treatment-free days in oral contraceptive and patch users, ovulation occurred significantly less with the patch compared with oral contraception.<sup>67</sup>

## Recommendations for Patch Detachment



**FIGURE 22.11**

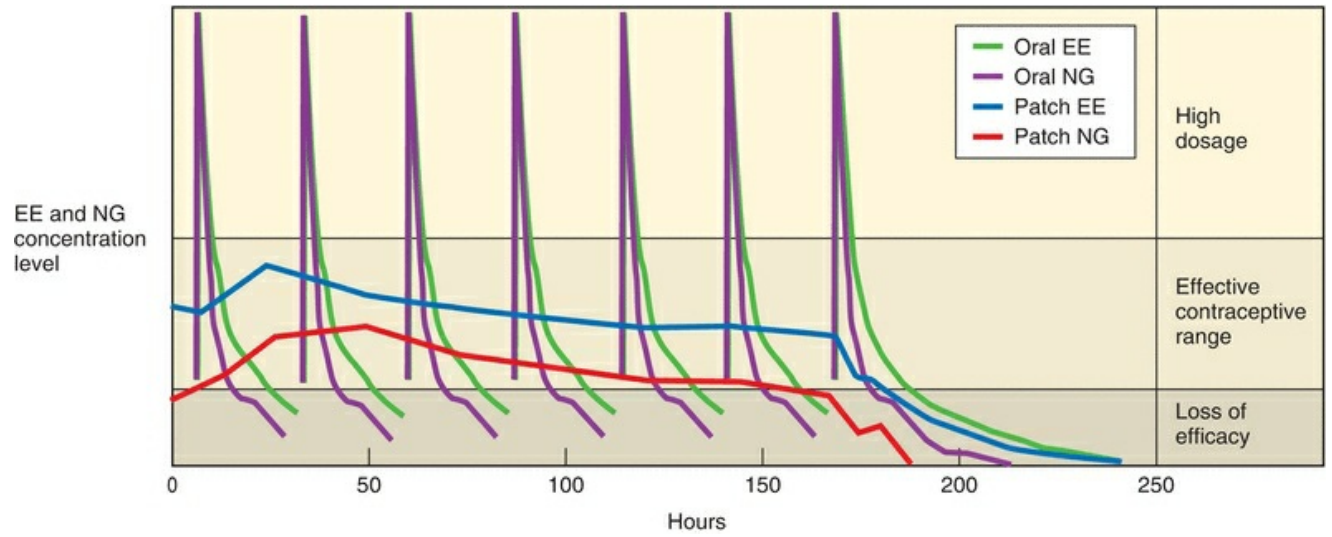
### Recommendations for When a New Patch Is Forgotten



**FIGURE 22.12**

**Transdermal contraception produces the same spectrum of actions associated with oral contraceptives, achieving the same high level of efficacy in clinical trials.** The avoidance of the liver first-pass effect offers the potential for less interaction with other drugs, but this is not known, and patients on medications that affect liver metabolism should choose an alternative contraceptive. Tetracycline administration does not affect the blood concentrations of the steroid hormones with transdermal contraception, a neutral impact as seen with oral contraceptives.<sup>112</sup>

Serum hormonal concentrations are achieved rapidly after application: an average of about 0.7 ng/mL, with a range of 0.6–1.2 ng/mL for norelgestromin, and an average of about 50 pg/mL, with a range of 25–75 pg/mL for ethinyl estradiol. These are ranges that are maintained by an oral formulation containing 250 mg norelgestromin and 35 mg ethinyl estradiol.<sup>113,114</sup> However, the kinetics are not identical to orally administered hormones; daily fluctuations are avoided. These blood levels allow maintenance of contraceptive efficacy if patch replacement is delayed up to 2 days.<sup>115</sup> Gonadotropin levels return to baseline values by 6 weeks after discontinuation.<sup>114</sup> Daily use has been well studied, and activities such as exercise, bathing, swimming, and the use of a sauna or hot tub do not cause detachment or changes in the blood levels of the hormones<sup>116</sup> (Figure 22.13).



**FIGURE 22.13**

# OFF-LABEL USES OF STEROID CONTRACEPTION

---

Steroid contraception is often used for noncontraceptive purposes. The list is long, including treatment of acne, dysmenorrhea, heavy or irregular vaginal bleeding, menses-associated mood changes, the polycystic ovary syndrome, and endometriosis. For most of the oral contraceptives' 50-year history, all of these have been "off-label" applications, but recently pharmaceutical companies have conducted trials to obtain label "indications" to use in advertising directed to both clinicians and consumers. In order to acquire such an indication, the company simply has to demonstrate that their formulation is better than a placebo at, for example, improving acne or relieving the symptoms of PMDD. Because these trials usually compare a product to a placebo or just to another contraceptive formulation, the studies do not reveal whether the product receiving approval for an "indication" is really better than others. Prices and formularies restrict patient access to the full range of oral contraceptives<sup>117</sup>; therefore, clinicians must make judgments by comparing findings from unrelated studies and experience to decide which pill to use for a specific purpose in an individual patient. In most cases, as we will emphasize, it is unlikely that there are major differences among similar products.

# POTENCY

---

For many years, clinicians, scientists, medical writers, and even the pharmaceutical industry attempted to assign potency values to the various progestational components of oral contraceptives. An accurate assessment, however, has been difficult to achieve for many reasons. Progestins act on numerous target organs (e.g., the uterus, the mammary glands, and the liver), and potency varies depending on the target organ and endpoint being studied. In the past, animal assays, such as the Clauberg test (endometrial change in the rabbit), were used to determine progestin potency. Although these were considered acceptable methods at the time, a better understanding of steroid hormone action and metabolism and a recognition that animal and human responses differ have led to greater reliance on data collected from human studies.

Historically, this has been a confusing issue because publications and experts used potency ranking to provide clinical advice. Oral contraceptive progestin potency is no longer a consideration when it comes to prescribing oral contraception, because the potency of the various progestins has been accounted for by appropriate adjustments of dose. Clinical advice based on potency ranking is an artificial exercise that has not stood the test of time. Oral contraceptives should be judged by their clinical characteristics: efficacy, side effects, risks, and benefits.



# MECHANISM OF ACTION

---

The combination pill, consisting of estrogen and progestin components, prevents ovulation by inhibiting gonadotropin secretion via an effect on both pituitary and hypothalamic centers. The progestational agent in the pill primarily suppresses LH secretion (and thus prevents ovulation), while the estrogenic agent suppresses FSH secretion (and thus prevents the emergence of a dominant follicle). Therefore, the estrogenic component significantly contributes to the contraceptive efficacy. However, even if follicular growth and development were not sufficiently inhibited, the progestational component would prevent the surge-like release of LH necessary for ovulation. The transdermal patch and vaginal ring's progestational and estrogenic components both work similarly.<sup>99,110,111</sup>

The estrogenic components serve two other purposes. It provides stability to the endometrium so that irregular shedding and unwanted breakthrough bleeding can be minimized, and the presence of estrogen is required to potentiate the action of the progestational agents. The latter function of estrogen has allowed reduction of the progestational dose in the pill. The mechanism for this action is probably estrogen's effect in increasing the concentration of intracellular progestational receptors. Therefore, a minimal pharmacologic level of estrogen is necessary to maintain the efficacy of the combination pill.

Because the effect of a progestational agent takes precedence over estrogen (unless the dose of estrogen is increased many, manyfold), the endometrium, cervical mucus, and perhaps tubal function reflect progestational stimulation. The progestin component produces an endometrium that is not receptive to ovum implantation, a decidualized bed with exhausted and atrophied glands. The cervical mucus becomes thick and impervious to sperm transport. It is possible that progestational influences on secretion and peristalsis within the fallopian tubes provide additional contraceptive effects.<sup>118,119</sup> Even if there is some ovarian follicular activity (especially with the lowest-dose products), these actions serve to ensure high contraceptive efficacy.<sup>120</sup>

# EFFICACY

---

In view of the multiple actions of combined hormonal contraceptives, it is hard to understand how the omission of a pill or two can result in a pregnancy (Table 22.1). Indeed, careful review of failures suggests that pregnancies usually occur because initiation of the next cycle is delayed allowing escape from ovarian suppression. Strict adherence to 7 pill-free or ring-free days is critical in order to obtain reliable, effective contraception. For this reason, the 28-day pill package, incorporating 7 pills that do not contain steroids, is a very useful aid to ensure adherence to the necessary schedule. Even better, the use of extended regimens or continuous dosing offers the potential to minimize, if not eliminate, pill failures.

**TABLE 22.1 Failure Rates During the First Year of Use, United States<sup>123,124</sup>**

Method	Percent of Women with Pregnancy	
	Lowest Expected	Typical
No method	85%	85%
Combination pill	0.3%	8.7%
Progestin only	0.5%	3.0%
IUDs:		
Levonorgestrel IUD	0.1%	0.1%
Copper T 380A	0.6%	1.0%
Implant	0.05%	1.0%
Injectable		
3-month	0.3	0.3%
1-month	0.05	3.0%
Patch	0.3	8.0%
Vaginal ring	0.3	8.0%
Female sterilization	0.5%	0.7%
Male sterilization	0.1%	0.2%
Spermicides	18.0%	29.0%
Periodic abstinence		25.3%
Calendar	9.0%	
Ovulation method	3.0%	
Symptothermal	2.0%	
Postovulation	1.0%	
Withdrawal	4.0%	18.4%
Cervical cap		
Parous women	26.0%	32.0%
Nulliparous women	9.0%	16.0%
Sponge:		
Parous women	20.0%	32.0%
Nulliparous women	9.0%	16.0%
Diaphragm and spermicides	6.0%	16.0%
Condom		
Male	2.0%	17.4%
Female	5.0%	27.0%

The most prevalent problems that can be identified associated with apparent oral contraceptive failures are vomiting and diarrhea.<sup>121,122</sup> **Even if no pills have been missed, patients should be instructed to use a backup method for at least 7 days after an episode of gastroenteritis. An alternative is to place the pill in the vagina during the illness.**

The contraceptive effectiveness of the new progestin oral contraceptives, multiphasic formulations, and lowest-estrogen dose products are unequivocally comparable with older low-dose (<50- $\mu$ g estrogen) and higher-dose monophasic combination birth control pills.<sup>123,124</sup>

In randomized trials ranging from 4 cycles to 13 cycles, about 10–20% more of the participants demonstrated good compliance with the transdermal method compared with oral contraception.<sup>108,110</sup> Most importantly, young women, especially those younger than age 20, demonstrated greater compliance with transdermal contraception compared with oral contraceptives than did older women.<sup>125</sup> Indeed, compliance is better at all ages comparing the patch to the pill.<sup>126</sup> Similarly, randomized control trials show better compliance with the NuvaRing than oral contraception, but no head-to-head comparison of failure rates has been completed.<sup>127,128</sup>

# **NONCONTRACEPTIVE EFFECTS OF ORAL CONTRACEPTION**

---

# Cardiovascular Disease

## The Coagulation System

Thrombosis can be divided into two major categories, venous thromboembolism and arterial thrombosis. Venous thromboembolism includes both deep vein thrombosis and pulmonary embolism. Arterial thrombosis includes acute myocardial infarction and stroke.

The goal of the clotting mechanism is to produce thrombin, which converts fibrinogen to a fibrin clot. Thrombin is generated from prothrombin by factor Xa in the presence of factor V, calcium, and phospholipids. The vitamin K–dependent factors include factors VII, IX, and X, as well as prothrombin. Antithrombin III is one of the body’s natural anticoagulants, an irreversible inhibitor of thrombin and factors IXa, Xa, and XIa. Protein C and protein S are two other major inhibitors of coagulation and are also vitamin K-dependent. Protein C and its helper, protein S, inhibit clotting at the level of factors V and VIII. Tissue plasminogen activator (t-PA) is produced by endothelial cells and released when a clot forms. Both t-PA and plasminogen bind to the fibrin clot. The t-PA converts the plasminogen to plasmin, which lyses the clot by degrading the fibrin. Deficiencies of antithrombin III, protein C, and protein S are inherited in an autosomal dominant pattern, accounting for 10–15% of familial thrombosis. The most common inherited causes of venous thromboembolism are the factor V Leiden mutation, followed distantly by a mutation in the prothrombin gene.<sup>129</sup>

### **Coagulation Factors:**

#### **Factors that favor clotting when increased:**

**Fibrinogen**

**Factors VII, VIII, X**

#### **Factors that favor clotting when decreased:**

**Antithrombin III**

**Protein C**

**Protein S**

### **Fibrinolysis Factors**

#### **Factors that favor clotting when increased**

**Plasminogen activator inhibitor-1 (PAI-1)**

## Factors that favor clotting when decreased

### Antiplasmin

An inherited resistance to activated protein C has been identified as the basis for about 50% of cases of familial venous thrombosis, due in almost all cases to a gene alteration recognized as the factor V Leiden mutation.<sup>130,131</sup> The factor V Leiden mutation is found in approximately 30% of individuals who develop venous thromboembolism.<sup>132</sup> Activated protein C inhibits coagulation by degrading factors V and VIII. One of the three cleavage sites in factor V is the precise site of a mutation known as the factor V Leiden mutation that substitutes glutamine instead of arginine at this site (adenine for guanine at nucleotide 1691 in the gene).<sup>132</sup> This mutation makes factor V resistant to degradation and activation in fibrinolysis. The entire clotting cascade is then resistant to the actions of the protein C system.

Heterozygotes for the factor V Leiden mutation have an 8-fold increased risk of venous thrombosis, and homozygotes have an 80-fold increased risk, and this risk is further enhanced by oral contraceptive use. The highest prevalence (3–4% of the general population) of factor V Leiden is found in Europeans, and its occurrence in populations not of European descent is very rare, perhaps explaining the low frequency of thromboembolic disease in Africa and Asia, and in Native Americans.<sup>133</sup> The mutation is believed to have arisen in a single ancestor approximately 21,000–34,000 years ago<sup>134</sup> and was perhaps initially a useful adaptation in heterozygotes in response to life-threatening bleeding, such as with childbirth.

The next most common inherited disorder after the factor V Leiden mutation is a mutation, a guanine to adenine change, in the gene encoding prothrombin.<sup>129,135</sup> The prevalence of this abnormality in the white population is estimated to range from 0.7% to 4%.<sup>136</sup> Oral contraceptive use has been reported to markedly increase the risk of venous thrombosis in carriers of the prothrombin mutation.<sup>137</sup> Perhaps other unidentified disorders make a contribution because an increased risk of venous thrombosis with oral contraceptives has been reported in women with elevated prothrombin levels despite an absence of the prothrombin gene mutation.<sup>138</sup>

The administration of pharmacologic amounts of estrogen as in high-dose oral contraceptives causes an increase in the production of clotting factors such as factor V, factor VIII, factor X, and fibrinogen.<sup>139</sup> The progestin component also influences the clotting factor responses.<sup>140</sup> Some studies of the blood coagulation system have concluded that both monophasic and multiphasic low-dose oral contraceptives have no significant clinical impact on the coagulation system. Slight increases in thrombin formation are offset by increased fibrinolytic activity.<sup>141,142</sup> Other studies of

formulations containing 30 and 35 µg of ethinyl estradiol indicate an increase in clotting factors associated with an increase in platelet activity.<sup>143</sup> However, these changes are essentially all within normal ranges and their clinical significance is unknown.<sup>144</sup> Transdermal administration has effects on clotting proteins and lipoproteins like those seen with low-dose oral contraceptives.<sup>145</sup>

Smoking produces a shift to hypercoagulability.<sup>137</sup> A 20-µg estrogen formulation has been reported to have no effect on clotting parameters, even in smokers.<sup>137,146</sup> One study comparing a 20-µg product with a 30-µg product found similar mild procoagulant and fibrinolytic activity, although there was a trend toward increased fibrinolytic activity with the lower dose.<sup>147</sup> These mixed reports make it essential to base clinical decisions on the epidemiologic studies of clinical events.

**There is no evidence of an increase in risk of cardiovascular disease among past users of oral contraception.<sup>148,149,150</sup> In the Nurses' Health Study, the Royal College of General Practitioners' study, and the Oxford Family Planning Association Study, long-term past use of oral contraceptives was not associated with an increase in overall mortality.<sup>151,152,153</sup> Part of the concern for a possible lingering effect of oral contraceptive use was based on a presumed adverse impact on the atherosclerotic process, which would then be added to the effect of aging and, thus, would be manifested later in life. Instead, the findings have been consistent with the contention that cardiovascular disease due to oral contraception is secondary to acute effects, specifically estrogen-induced thrombosis, a dose-related event.**



# Venous Thromboembolism

Older epidemiologic evaluations of hormonal contraceptives and vascular disease indicated that venous thrombosis was an effect of estrogen, limited to current users, with a disappearance of the risk by 3 months after discontinuation.<sup>154,155</sup> Thromboembolic disease was believed to be a consequence of the pharmacologic administration of estrogen, and the level of risk was believed to be related to the estrogen dose.<sup>156,157,158</sup> Smoking was documented to produce an additive increase in the risk of arterial thrombosis<sup>159,160,161</sup> but had no effect on the risk of venous thromboembolism.<sup>162,163</sup>

Is there still a risk of venous thromboembolism with the current low-dose (<50 µg ethinyl estradiol) formulations of oral contraceptives? In the first years of oral contraception, the available products, containing 80 and 100 µg ethinyl estradiol (an extremely high dose), were associated with a sixfold increased risk of venous thrombosis.<sup>164</sup> Because of the increased risks for venous thrombosis, myocardial infarction, and stroke, lower-dose formulations (<50 µg estrogen) came to dominate the market, and clinicians became more careful in their screening of patients and prescribing of oral contraception. Two forces, therefore, were at work simultaneously to bring greater safety to women utilizing oral contraception: (1) the use of lower-dose formulations and (2) the avoidance of oral contraception by high-risk patients. Because of these two forces, the Puget Sound study in the United States documented a twofold reduction in venous thrombosis risk.<sup>165</sup> The new studies also reflect the importance of these two forces, but they still indicate an increased risk.

The World Health Organization (WHO) Collaborative Study of Cardiovascular Disease and Steroid Hormone Contraception was a hospital-based, case-control study with subjects collected from 21 centers in 17 countries in Africa, Asia, Europe, and Latin America.<sup>166</sup> As part of this study, the risk of **idiopathic** venous thromboembolism associated with a formulation containing 30 µg ethinyl estradiol and levonorgestrel (doses ranging from 125 to 250 µg) was compared with the risk with preparations containing 20 or 30 µg ethinyl estradiol and either desogestrel or gestodene (data from 10 centers in 9 countries).<sup>167</sup> The users of the levonorgestrel formulations had an increased odds ratio of 3.5 compared with nonusers. Current users of a desogestrel or gestodene product had an increased risk of 9.1 compared with nonusers. Thus, the increased risk for desogestrel and gestodene was 2.6 times that of levonorgestrel, when adjusted for body weight and height.

The Transnational Study on Oral Contraceptives and the Health of Young Women analyzed 471 cases of deep vein thrombosis and/or venous thromboembolism from the United Kingdom and Germany.<sup>168</sup> Second-generation oral contraceptives were defined as products containing 35 µg or less of ethinyl estradiol and a progestin other than

desogestrel or gestodene. Comparing users of second-generation products to nonusers, the odds ratio was 3.2. Comparing users of desogestrel and gestodene products to users of second-generation oral contraceptives, the risk of venous thromboembolism was 1.5-fold greater.

A third major study was from Boston University, but the data were derived from the General Practice Research Database, a computerized system involving the general practitioners in the United Kingdom.<sup>169</sup> Using this cohort, the death rate from pulmonary embolism, stroke, and acute myocardial infarction was calculated in the users of levonorgestrel, desogestrel, and gestodene low-dose oral contraceptives. Over a 3-year period, they collected a total of 15 unexpected idiopathic cardiovascular deaths in users of these products, a **nonsignificant change**, and no difference in the risk comparing desogestrel and gestodene with levonorgestrel. The risk estimates for venous thromboembolism (adjusted for smoking and body size) were about 2 times greater for desogestrel and for gestodene, compared with levonorgestrel users. In an updated analysis from this same group and database, the findings were unchanged, except that smoking was found to be a risk factor for venous thromboembolism.<sup>170</sup> An American case-control study concluded that norgestimate- and levonorgestrel-containing oral contraceptives had similar risks for venous thromboembolism, but there was a small increase in risk associated with desogestrel.<sup>171</sup>

Similar results were reported when women with deep vein thrombosis in the Leiden Thrombophilia Study in the Netherlands were reanalyzed for their use of oral contraceptives.<sup>172</sup> As expected, the risk of deep vein thrombosis was markedly higher in women who were carriers of the factor V Leiden mutation and in women with a family history of thrombosis.

In Denmark, a hospital-based, case-control study of women with confirmed diagnoses of venous thromboembolism in 1994 and 1995 (in Denmark, all women with this diagnosis are hospitalized, and therefore, very few, if any, cases were missed) revealed a twofold increased risk of venous thromboembolism in current users of oral contraceptives, regardless of estrogen doses ranging from 20 to 50  $\mu\text{g}$ .<sup>173</sup> The increased risk was concentrated in the first year of use. **Because there were more short-term users of the new progestins and more long-term users of the older progestins, adjustment for duration of use resulted in no significant differences between the different types of progestins.** Those factors associated with an increased risk of thromboembolism included coagulation disorders, treated hypertension during pregnancy, family history of venous thromboembolism, and an increasing body mass index (BMI). Notably, conditions not associated with an increased risk of venous thromboembolism included smoking, migraine, diabetes, hyperlipidemia, parity, or age at first birth. There was still insufficient strength in this study to establish the absence or

presence of a dose-response relationship comparing the 20- $\mu\text{g}$  estrogen dose to higher doses; however, a 5-year update reported the following useful information<sup>174</sup>:

- The risk of venous thrombosis associated with current use of oral contraceptives declined with increasing duration of use.
- The risk was slightly greater with desogestrel or gestodene.
- Smoking more than 10 cigarettes per day increased the risk.
- Oral contraceptives with 20  $\mu\text{g}$  estrogen had a lower risk than products with 30–40  $\mu\text{g}$ .
- Progestin-only contraceptive products did not increase the risk.

Case-control studies using cases of venous thromboembolism derived from the computer records of general practices in the United Kingdom concluded that the increased risk associated with oral contraceptives was the same for all types and that the pattern of risk with specific oral contraceptives suggested confounding because of “preferential prescribing” (defined later).<sup>175,176</sup> **In these studies, matching cases and controls by year of birth eliminated differences between different types of oral contraceptives.** A similar analysis based on 42 cases from a German database again found no difference between new progestin and older progestin oral contraceptives.<sup>177</sup> Thus, in these two studies, more precise adjustments for age eliminated a confounding bias. An assessment of the incidence of venous thromboembolism in the United Kingdom before and after the decline in third-generation progestin use could detect no impact on the statistics (neither an increase nor a decrease).<sup>178</sup>

A reanalysis of the transnational case-control study considered the duration and patterns of oral contraceptive use, focusing on if low-dose estrogen contraceptives with different progestins had significantly different risks of thromboembolism.<sup>179,180</sup> This reanalysis focused on first-time users of second- and third-generation oral contraceptives. **Statistical analysis with adjustment for duration of use in 105 cases who were first-time users could find no differences between second- and third-generation products. A similar reanalysis of the U.K. General Practice Database could demonstrate no difference between different oral contraceptive formulations.**<sup>181</sup>

A case-control study in Germany assessed the outcome when the cases were restricted to hospitalized patients compared to results when all cases, both in-hospital and out-of-hospital, were considered.<sup>182</sup> The conclusion indicated that hospital-based studies overestimated the risk of venous thromboembolism and that there was no difference comparing progestins when all cases were included.

Former users discontinue oral contraceptives for a variety of reasons and often are

switched to what clinicians perceive to be “safer” products, a practice called **preferential prescribing**.<sup>183,184,185</sup> Individuals who do well with a product tend to remain with that product. Thus, at any one point in time, individuals on an older product will be relatively healthy and free of side effects—the **healthy user effect**. This is also called **attrition of susceptibles** because higher-risk individuals with problems are gradually eliminated from the group.<sup>186</sup> **Comparing users of older and newer products, therefore, can involve disparate cohorts of individuals.**

Because desogestrel- and gestodene-containing products were marketed as less androgenic and therefore “better” (a marketing claim not substantiated by epidemiologic studies), clinicians chose to provide these products to higher-risk patients and older women.<sup>183,184</sup> In addition, clinicians switched patients perceived to be at greater risk for thrombosis from older oral contraceptives to the newer formulations with desogestrel and gestodene. Furthermore, these products were prescribed more often to young women who were starting oral contraception for the first time (these young women will not have experienced the test of pregnancy or previous oral contraceptive use to help identify those who have an inherited predisposition to venous thrombosis). These changing practice patterns exert different effects over the lifetime of a product, and analytical adjustments are extremely difficult.

The initial studies were impressive in their agreement. All indicated increased relative risks associated with desogestrel and gestodene compared with levonorgestrel. Nevertheless, all of the early studies, somewhat similar in design, were influenced by the same unrecognized biases. **Persistent errors will produce consistent conclusions.**

Forty cases of venous thrombosis in drospirenone (Yasmin) users (two of which were fatal) were reported in Europe in 2002.<sup>187</sup> The Dutch College of General Practitioners issued a statement encouraging clinicians not to prescribe Yasmin. However, this is the similar story we experienced with “third-generation” progestins, only to learn that preferential prescribing and the healthy user effect probably biased the early case-control studies. In postmarketing surveillance, only one case of venous thrombosis occurred in a million cycles of Yasmin compared with five among users of other oral contraceptives.<sup>187</sup> In a subsequent monitoring study, the incidence of venous thromboembolism in new users was comparable to that seen with other low-dose oral contraceptives.<sup>188</sup> The European Active Surveillance Study (EURAS) was a large cohort study that enrolled **only new users** of oral contraceptives containing a variety of progestins, including drospirenone and levonorgestrel.<sup>189</sup> The incidence of cardiovascular events was similar for all progestins. An American cohort study also focused on new users of oral contraceptives, and thromboembolism occurred at a similar low rate comparing drospirenone users with other oral contraceptives.<sup>190</sup>

Investigators from Denmark and Netherlands continued their interest in hormonal contraception and venous thrombosis, performing a national cohort study using the reliable Danish national registries of events from 1995 to 2005 and a case-control study focusing on short-term users of desogestrel, gestodene, drospirenone, cyproterone, and levonorgestrel.<sup>191,192</sup> As in the earlier Danish case-control study,<sup>174</sup> the risk of venous thrombosis in current users of oral contraceptives decreased with duration of use and with the dose of estrogen and was slightly higher with products containing desogestrel, gestodene, drospirenone, and cyproterone as compared to levonorgestrel. Did these studies escape the problems of preferential prescribing and the healthy user effect? The incidence of thrombotic events in the comparator group (levonorgestrel users) was lower than that reported in other studies, suggesting that this group did demonstrate a healthy user effect. These studies were not limited to new users, a requirement in order to avoid the confounding due to attrition of susceptibles. Additionally, the Danish study was unable to control for BMI or family history of thrombosis, two important markers for women at high risk of venous thrombosis. Preferential prescribing remains a possible confounder in the Danish study; however, the problem of a healthy user effect is even more likely.

The International Active Surveillance Study of Women Taking Oral Contraceptives (INAS-OC), designed to record cardiovascular events in a cohort of more than 80,000 new oral contraceptive users, aimed to determine if different progestins paired with a low-dose estrogen in an oral contraceptive pill have different thromboembolic risks.<sup>193</sup> Six-year follow-up data comparing new users of the drospirenone-containing pill 24-day regimen and 21-day regimen, levonorgestrel-containing pills, and oral contraceptive pills not containing drospirenone show no difference in risk of thromboembolic disease, fatal outcomes, cancer, and severe depression.<sup>194</sup>

**The risk of venous thrombosis associated with modern oral estrogen-progestin contraceptives is increased about twofold but manifested primarily in the first years of use and concentrated in overweight women.<sup>189,195,196</sup> The risk, which increases with increasing body weight and age, is influenced in a major way by the estrogen dose, and the difference among progestin products is likely a reflection of biases and confounders. The impact of smoking on the risk of venous thrombosis is less than that on the risk of arterial thrombosis, but smoking, especially heavy smoking, may act synergistically with oral contraceptives.<sup>197</sup>**

**The risk of venous thromboembolism in the general population is now considered to be higher than previously estimated because of the prevalence of modern diagnostic methods. The new studies also indicate that the risk associated with low-dose oral contraceptives is lower than previously reported and more prevalent in high-risk individuals (Table 22.2) (obesity and inherited or acquired**

thrombophilias). Oral contraceptives with the lowest doses of estrogen should be used for overweight and older women, but progestin-only methods are an even better choice.

**TABLE 22.2 Relative Risk and Actual Incidence of Venous Thromboembolism<sup>193,195,205</sup>**

Population	Relative Risk	Incidence
Young women—general population	1	5–10/10,000/year
Pregnant women	12	60–120
High-dose oral contraceptives	6–10	30–100
Low-dose oral contraceptives	2	10–20
Leiden mutation carrier	6–8	30–80
Leiden carrier and oral contraceptives	10–15	50–100
Leiden mutation—homozygous	80	400–800

As for transdermal contraceptives, the FDA issued a press release on November 10, 2005, calling attention to the fact that women using the transdermal contraceptive patch are exposed over time to a greater amount of estrogen. Subsequently, the patch labeling was updated to include a warning about this higher exposure. Here are the facts:

1. The contraceptive patch delivers daily 20 mg ethinyl estradiol and 150 µg norelgestromin (the primary active metabolite of orally administered norgestimate).
2. The peak estrogen blood levels with the contraceptive patch are about 25–35% lower compared with oral products containing 30 or 35 mg ethinyl estradiol.<sup>198</sup>
3. Over time, without the peaks and nadirs experienced by oral contraceptive users, patch users are exposed to about 60% more estrogen compared with an oral

product containing 35 mg ethinyl estradiol.

Which is more important, a higher peak level or greater exposure over time? The first concern that there might be an increased risk of venous thrombosis with the patch was a consequence of stories in the media based on anecdotal reports provided to the FDA (a numerator without a denominator). In response, Johnson & Johnson, the parent company for the contraceptive patch, provided research funds for three epidemiologic studies, comparing transdermal and oral contraception.

The first case-control study of nonfatal venous thrombosis used information derived from a very large database that records prescriptions and diagnoses longitudinally in managed health care plans.<sup>199</sup> The study over a 3-year time period compared new users of the contraceptive patch with new users of an oral contraceptive containing 35 mg ethinyl estradiol and norgestimate. Sixty-eight cases of venous thrombosis and 266 controls were identified and matched for year of birth and for the date of the thrombotic episode (thus providing comparable dates for exposure). An extension of this study added 56 more cases of venous thrombosis.<sup>200</sup> A comparison of the patch to the oral contraceptive indicated no difference in the risk of venous thrombosis.

The second case-control study indicated that the use of the transdermal contraceptive system was associated with a 2.4-fold increase in the risk of venous thromboembolism compared with users of a 35-mg ethinyl estradiol and norgestimate oral contraceptive.<sup>201</sup> The study used insurance claims data from a major national provider of health insurance to identify women using transdermal or oral contraception. A limitation of the study was the inability to confirm diagnoses in 100% of the cases through review of medical records (completed for 83% of the cases). A strength of the study was the thorough attempt to control for factors that influence venous thrombosis. A strong point of both studies was a focus on new users, eliminating the problem known as attrition of susceptibles. Comparing new users, who are more likely to experience venous thrombosis, to old users would be comparing two different groups of subjects.

A postmarketing study compared the rate of venous thromboembolism in patch users and users of oral contraceptives containing levonorgestrel and 30 mg ethinyl estradiol.<sup>202</sup> The difference between the two methods was **not** statistically significant.

Comparing the two case-control studies, it is worth noting that the negative report had about 6 times as many cases as the positive report, giving it more statistical power. Indeed, in the overall case-control analysis in the positive report, there were only 20 cases among transdermal users and 37 cases among oral contraceptive users, and the odds ratio of 2.0 was close, but it did not reach statistical significance. After excluding cases and controls with high-risk factors, the odds ratio with 16 transdermal cases and 26 oral contraceptive cases achieved 2.4 with statistical significance, but with a



relatively very wide confidence interval, 1.1–5.5.

These are the only epidemiologic data on this important issue. One case-control study is reassuring; one case-control study is disturbing. Because the confidence intervals of the two studies are within the same range (i.e., they overlap), it is not certain that the different results do not reflect a chance finding. At this point in time, it seems that if there is a difference in the risk of venous thrombosis comparing transdermal and oral contraception, the difference has to be very small. Certainly, the available evidence does not indicate a major difference.

# Venous Thromboembolism and Thrombophilias

An inherited resistance to activated protein C, the factor V Leiden mutation, may account for a significant portion of the patients who experience venous thrombosis while taking oral contraceptives.

The factor V Leiden mutation is the most common inherited coagulation problem, transmitted in an autosomal dominant fashion.<sup>103,203</sup> Heterozygotes have a 6- to 8-fold increased risk of venous thromboembolism, and homozygotes an 80-fold increased risk. Oral contraceptive users who have this mutation (heterozygotes or homozygotes) have been reported to have a 30-fold increased risk of venous thrombosis.<sup>204,205</sup> Some have argued that this increase has been overestimated, and it is closer to 10–15-fold.<sup>206</sup> The risk of developing venous thrombosis is greatest in the initial months of use, and venous thrombosis occurring in the first month of exposure should make the clinician suspect the presence of a clotting disorder.<sup>207</sup>

Should screening for the factor V Leiden mutation (or for other inherited clotting disorders) be routine prior to prescribing contraceptives? The carrier frequencies of the Leiden mutation in the American population (the percentages are similar in men and women) are shown in [Table 22.3](#).<sup>208</sup>

## TABLE 22.3

Caucasian Americans	5.27%
Hispanic Americans	2.21%
Native Americans	1.25%
Black Americans	1.23%
Asian Americans	0.45%

These estimates are consistent with European assessments, indicating that this is a trait carried in people of European origin. About 1 in 5,000 individuals is homozygous for the Leiden mutation. In the United States, of the approximately 12 million women currently using oral contraceptives, about 540,000 are likely to carry the factor V Leiden mutation. However, because the incidence rate of venous thromboembolism is so low (5–10 per 10,000 young women per year), the number of women required to be screened to prevent one event is prohibitively large. The prevalence of all deficiencies is only about 0.5% in the asymptomatic population, and only one-third of patients at risk are detected by the present tests.<sup>209</sup>

Furthermore, because only a small number of women even with the Leiden mutation (<1 in 1,000) have a clinical event (99.85% of the individuals who test positive will NOT have a clinical event!), the finding of a positive screening test, especially considering the high rate of false-positive tests, would be a barrier to the use of oral contraceptives, and a subsequent increase in unwanted pregnancies would likely follow. Pregnancy, of course, has a much greater risk of venous thromboembolism than oral contraceptives. **Most experts believe that screening for inherited disorders should be pursued only in women with a previous episode of venous thromboembolism or a close positive family history (parent or sibling) of venous thrombosis.**

The second most prevalent inherited thrombophilia is the prothrombin gene 20210A mutation. A combination of the prothrombin gene mutation and the Leiden mutation is found in about 2% of venous thromboembolism cases.<sup>210</sup> Less frequent are genetic defects in coagulation inhibitors (antithrombin, protein C, and protein S), but these defects carry a substantial increase in risk.

Acquired thrombophilias include the presence of antiphospholipid antibodies (lupus anticoagulant and anticardiolipin) usually associated with autoimmune diseases.

**The inherited and acquired thrombophilias predispose to venous**

**thromboembolism in a synergistic manner with estrogen-containing contraceptives. However, the actual incidence of events is low, and identification of a thrombophilia does not predict a clinical event.**

# Arterial Thrombosis

Cerebral thrombotic attacks (thrombotic strokes and transient ischemic attacks) among young women carry a high rate of death and disability and are therefore an important side effect of hormonal contraception. Nevertheless, the incidence is low, and a small increase in the very low incidence of stroke in young women carries with it little increase in absolute risk. Because the incidence of cerebral thrombotic attacks is higher in women over age 40, we should do our best, as the following discussion will indicate, to make sure estrogen-progestin contraceptive users over age 40 are in good health and without significant risk factors for cardiovascular disease (especially hypertension, migraine with aura, and smoking).

Although it has been difficult to establish arterial thrombosis dose-response relationships with estrogen because these events are so rare, modern, lower estrogen doses are related to the risk of myocardial infarction and thrombotic strokes in case-control studies.<sup>211,212</sup> Thus, a rationale for advocating low-dose estrogen oral contraceptives continues to be valid.

# Arterial Thrombosis—Myocardial Infarction

A population-based, case-control study analyzed 187 cases of myocardial infarction in users of low-dose oral contraceptives in the Kaiser Permanente Medical Care Program.<sup>213</sup> **There was no statistically significant increase in the odds ratio for myocardial infarction in current oral contraceptive users compared with past or never-users.**

In the transnational case-control study of myocardial infarctions collected from 16 centers in Austria, France, Germany, Switzerland, and the United Kingdom, cigarette smoking carried a higher risk for myocardial infarction than oral contraceptives, and **nonsmoking users of oral contraceptives had no evidence of an increased risk.**<sup>214,215</sup> In addition, there was an indication that patient screening is important in minimizing the impact of hypertension on the risk of myocardial infarction. Similar results were reported in a case-control study based on subjects in England, Scotland, and Wales and another in America.<sup>216,217</sup>

In the WHO multicenter study, there were 368 cases of acute myocardial infarction.<sup>218</sup> Factors associated with an increased risk of myocardial infarction included smoking, a history of hypertension (including hypertension in pregnancy), diabetes, rheumatic heart disease, abnormal blood lipids, and a family history of stroke or myocardial infarction. Duration of use and past use of oral contraceptives did not affect risk. Although there was about a fivefold overall increased odds ratio of myocardial infarction in current users of oral contraceptives, essentially all cases occurred in women with cardiovascular risk factors. There was no apparent effect of increasing age on risk; however, there were only 12 cases among oral contraceptives users less than 35 years old. There was no apparent relationship with estrogen dose, and there was no apparent influence of type or dose of progestin, but the rare occurrence of this condition produced such small numbers that there was insufficient statistical power to accurately assess the effects of progestin type and estrogen and progestin doses. **The conclusion of this study was that the risk of myocardial infarction in women who use oral contraceptives is increased only in smokers.**

**In a Danish case-control study of acute myocardial infarction in young women, a statistically significant increase in risk was noted only in current users of 50 µg ethinyl estradiol.**<sup>216</sup> There was a progressive increase in risk with the number of cigarettes smoked (accounting for 80% of the acute myocardial infarctions in young women), increasing BMI, treated hypertension, treated hypertension in pregnancy, diabetes mellitus, hyperlipidemia, frequent migraine, and family history of myocardial infarction. However, only family history of myocardial infarction and smoking affected the risk associated with oral contraceptives; no influence on oral contraceptive risk was

apparent with diabetes, hypertension, and heart disease. No differences could be demonstrated according to type of progestin.

A case-control study from the Netherlands found that the risk of myocardial infarction was highest among users of oral contraceptives who smoked, had diabetes mellitus, or who were hypercholesterolemic.<sup>219</sup> The risk of myocardial infarction was not affected by the presence of the factor V Leiden mutation or the prothrombin gene mutation.

The Women's Lifestyle and Health Cohort Study is a prospective cohort study of 106,841 Norwegian and Swedish women, started in 1991, specifically designed to assess the long-term health effects of hormonal contraceptives.<sup>220</sup> Low-dose (<50 µg ethinyl estradiol) oral contraceptives were not associated with an increased risk of myocardial infarction. All previous cohort studies date back to oral contraceptive use with higher doses of estrogen in the 1970s and 1980s. For example, in the report from the Nurses' Health Study in 1988, an increased risk of myocardial infarction was found in current users.<sup>221</sup>

Case-control studies of low-dose estrogen oral contraceptives have concluded that an increased risk of arterial disease occurs only in women who have hypertension or are smokers.<sup>118,213,214,217,219</sup> The cohort studies don't help us with this important issue because the numbers are too small for definitive analyses of subgroups. Nevertheless, British and Finnish cohorts were reported to have increased risks of developing myocardial infarction in oral contraceptive users who smoked<sup>222,223</sup> (Table 22.4).

## **TABLE 22.4 Incidence of Myocardial Infarction in Reproductive-Age Women<sup>216</sup>**

**Overall Incidence<sup>222</sup>****5/100,000/year**

## Women &lt; age 35

Nonsmokers 4/100,000/year

Nonsmokers and OCs 4/100,000/year

Smokers 8/100,000/year

Smokers and OCs 43/100,000/year

## Women 35 years old and older

Nonsmokers 10/100,000/year

Nonsmokers and OCs 40/100,000/year

Smokers 88/100,000/year

Smokers and OCs 485/100,000/year

NOTE: The above incidences are estimates based on oral contraceptive use paired with cardiovascular risk factors prevalent in the general population. Effective screening would produce smaller numbers. The increased risks in the smokers and OC groups reflect the impact of undetected cardiovascular risk factors, especially hypertension.

A case-control study addressing new users of transdermal contraception with new users of oral contraception detected no difference in the rates of myocardial infarction or stroke.<sup>224</sup>



# Arterial Thrombosis—Stroke

Older case-control and cohort studies indicated an increased risk of cerebral thrombosis among current users of high-dose oral contraceptives.<sup>225,226,227</sup> However, new studies show overall that ischemic and hemorrhagic stroke does not appear to be increased in healthy, nonsmoking women with the use of oral contraceptives containing less than 50 µg ethinyl estradiol.<sup>228,229,230,231,232,233</sup> A case-control study of all 794 women in Denmark who suffered a cerebral thromboembolic attack during 1985–1989 concluded that there was an almost twofold increased relative risk associated with oral contraceptives containing 30–40 µg estrogen, though the risk was significantly influenced by both smoking and the dose of estrogen in additive (not synergistic) fashion.<sup>231</sup> Similarly, the transnational study found a threefold increase in the risk of ischemic stroke associated with the use of oral contraceptives, though with higher risks observed in smokers (more than 10 cigarettes per day), in women with hypertension, and in users of higher-dose estrogen products.<sup>230</sup>

A population-based, case-control study of 408 strokes from the California Kaiser Permanente Medical Care Program found no increase in risk for either ischemic stroke or hemorrhagic stroke on low-dose oral contraception.<sup>229</sup> The identifiable risk factors for ischemic stroke were smoking, hypertension, diabetes, elevated body weight, and low socioeconomic status. The risk factors for hemorrhagic stroke were the same plus greater body mass and heavy use of alcohol. **Current users of low-dose oral contraceptives did not have an increased risk of ischemic or hemorrhagic stroke compared with former users and with never-users.** There was no evidence for an adverse effect of increasing age or for smoking (for hemorrhagic stroke, there was a suggestion of a positive interaction between current oral contraceptive use and smoking, but the numbers were small, and the result was not statistically significant).

The World Health Organization data on stroke come from the same collaborative study that yielded the publications on venous thromboembolism. The results with stroke were published as two separate reports, one on ischemic stroke and the other on hemorrhagic stroke.<sup>234,235</sup>

This hospital-based, case-control study from 21 centers in 17 countries accumulated 697 cases of ischemic stroke, 141 from Europe and 556 from developing countries.<sup>234</sup> The overall odds ratio for ischemic stroke indicated about a threefold increased risk. In Europe, however, the risk was statistically significant only for higher-dose products and **not** statistically significant for products with less than 50 µg ethinyl estradiol. In developing countries, there was no difference in risk with low-dose and higher-dose oral contraceptives. This is believed to be due to the strong influence of hypertension. In Europe, it was uncommon for women with a history of hypertension to be using oral

contraceptives; however, this was not the case in developing countries. Duration of use and type of progestin had no impact, and past users did not have an increased risk, but smoking 10 or more cigarettes daily exerted a synergistic effect with oral contraceptives, increasing the risk of ischemic stroke, approximating the effect of hypertension and oral contraceptives. The risk was greater in women 35 years and older; however, this, too, was believed to be due to an effect of hypertension. **Thus, the conclusion of this study was that the risk of ischemic stroke is extremely low, concentrated in those who use higher-dose products, smoke, or have hypertension.**

In the WHO study on hemorrhagic stroke, there were 1,068 cases.<sup>235</sup> Current use of oral contraceptives was associated with a slightly increased risk of hemorrhagic stroke only in developing countries, not in Europe. This again probably reflects the presence of hypertension, because the greatest increased risk (about 10- to 15-fold) was identified in current users of oral contraceptives who had a history of hypertension. Current cigarette smoking also increased the risk in oral contraceptive users, but not as dramatically as hypertension. For hemorrhagic stroke, the dose of estrogen had no effect on risk, and neither did duration of use or type of progestin. **This study concluded that the risk of hemorrhagic stroke due to oral contraceptives is increased only slightly in older women, probably occurring only in women with risk factors such as hypertension.**

A second Danish case-control study included thrombotic strokes and transitory cerebral ischemic attacks analyzed together as cerebral thromboembolic attacks.<sup>222</sup> In this study, the 219 cases during 1994 and 1995 included 146 cases of cerebral infarction and 73 cases of transient ischemic attacks. There was a dose-response relationship with estrogen in the dose ranges of 20, 30–40, and 50 µg ethinyl estradiol, although the number of 20 µg users (5 cases, 22 controls) was not sufficient to establish a lower risk at this lower dose. An updated 5-year report of the Danish case-control study indicated that the odds ratio of cerebral thrombosis decreased from a high of 4.5 with 50-µg estrogen pills to 1.6 with 20–40-µg pills.<sup>236</sup> Hypertension increased the risk 5-fold, migraine 3.2 times, diabetes 5.6 times, and hyperlipidemia and coagulation disorders about 12-fold.

The Norwegian-Swedish Women's Lifestyle and Health Cohort Study supports the conventional wisdom of the last decade that low-dose oral contraceptives do not increase the myocardial infarction or stroke in healthy, nonsmoking women, regardless of age.<sup>237</sup> Screening for hypertension is especially important in that it is a major risk factor for stroke associated with oral contraceptive use.

Again, there was concern that drospirenone-containing low-dose contraceptive pills may have an increased risk of arterial thrombotic events. A cohort study looking comparing women on a drospirenone-30-µg ethinyl estradiol pill to levonorgestrel with

20–30 µg of ethinyl estradiol did find an increased hazard ratio of 2.01 for arterial thrombosis among drospirenone users aged 35–55, but this study did not control for obesity, family history of embolic disease, or smoking status.<sup>238</sup>

**In the absence of hypertension, the effect of smoking in women under age 35 is too small to be measured. In the presence of hypertension, it is currently believed that with medical control of blood pressure and close follow-up (blood pressure monitoring every 3 months), nonsmoking women under age 35 and otherwise healthy can use low-dose oral contraception (Table 22.5).**

## **TABLE 22.5 Incidence of Stroke in Reproductive-Age Women<sup>222, 226,231,232</sup>**

Incidence of ischemic stroke

5/100,000/year

1–3/100,000/year in women  
under age 35

10/100,000/year in women over  
age 35

Incidence of hemorrhagic stroke

6/100,000/year

Excess cases per year due to  
OCs, including smokers and  
hypertensives

2/100,000/year in low-dose OC  
users

1/100,000/year in low-dose OC  
users under age 35

8/100,000/year in high-dose  
users

## **Conclusion—Myocardial Infarction and Stroke**

**Oral contraceptives containing less than 50 µg ethinyl estradiol do not increase the risk of myocardial infarction or stroke in healthy, nonsmoking women, regardless of age.** The effect of smoking in women under age 35 is, as we have long recognized, not detectable in the absence of hypertension. After age 35, the subtle presence of hypertension makes analysis difficult, but the Kaiser study indicates that increasing age and smoking by themselves have little impact on the risk of stroke in low-dose oral contraceptive users. The screening of patients in the Kaiser program was excellent, resulting in few women with hypertension using oral contraceptives. **There is no reason to doubt that these conclusions apply as well to the transdermal and vaginal methods of steroid contraception.**

Epidemiologic studies fail to find any substantial risk of ischemic or hemorrhagic stroke with low-dose oral contraceptives in healthy, young women. The WHO study did find evidence for an adverse impact of smoking in women under age 35; the Kaiser study did not. This difference is explained by the confounding effect of hypertension, the major risk factor identified. In the WHO study, a history of hypertension was based on whether a patient reported ever having had high blood pressure (other than in pregnancy) and not validated by medical records. In the Kaiser study, women were classified as having hypertension if they reported using antihypertensive medication (<5% of oral contraceptive users had treated hypertension, and there were no users of higher-dose products). In the WHO study, the effect of using oral contraceptives in the presence of a high-risk factor is apparent in the different odds ratios when European women who received good screening from clinicians were compared with women in developing countries who received little screening; therefore, more women with cardiovascular risk factors in developing countries were using oral contraceptives. **The studies indicate that hypertension should be a major concern, especially in regard to the risk of stroke.**

Over the years, there has been recurring discussion over whether to provide oral contraceptives over-the-counter on a nonprescription basis. The data in the WHO study make an impressive argument against such a move. The increased risk of myocardial infarction was most evident in developing countries where 70% of the cases received their oral contraceptives from a nonclinical source. Deprived of screening, women with risk factors in developing countries were exposed to greater risk.

# Smoking and Oral Contraception

Smoking continues to be a difficult problem, not only for patient management but for analysis of data as well. In large US surveys in 1982 and 1988, the decline in the prevalence of smoking was similar in users and nonusers of oral contraception; however, 24.3% of 35- to 45-year-old women who used oral contraceptives were smokers.<sup>239</sup> In this group of smoking, oral contraceptive–using women, 85.3% smoked 15 or more cigarettes per day (heavy smoking). Despite the widespread teaching and publicity that smoking is a contraindication to oral contraceptive use over the age of 35, more older women who use oral contraceptives smoke and smoke heavily, compared with young women. This strongly implies that older smokers are less than honest with clinicians when requesting oral contraception or that clinicians do not all accurately screen for tobacco use; this further raises serious concern over how well this confounding variable can be controlled in case-control and cohort studies. Studies documenting the effects of smoking bans on hospital admissions for myocardial infarctions indicate a rapid reduction in 6 months to a year.<sup>240,241</sup> **A former smoker must have stopped smoking for at least 6 consecutive months and preferably 12 months to be regarded as a nonsmoker. Women who have nicotine in their bloodstream obtained from patches or gum should be regarded as smokers.**

# Lipoproteins and Oral Contraception

The balance of estrogen and progestin potency in a given oral contraceptive formulation can potentially influence cardiovascular risk by its overall effect on lipoprotein levels. Oral contraceptives with relatively high doses of progestins (doses not used in today's low-dose formulations) do produce unfavorable lipoprotein changes.<sup>242</sup> The levonorgestrel triphasic exerts no significant changes on HDL cholesterol, LDL cholesterol, and apoprotein B and no change or an increase in apoprotein A. The monophasic desogestrel and desogestrel pills have a favorable effect on the lipoprotein profile, while the triphasic norgestimate and gestodene pills produce beneficial alterations in the LDL/HDL and apoprotein B/apoprotein A ratios.<sup>243,244,245,246</sup> Like the triphasic levonorgestrel pills, norethindrone multiphasic pills have no significant impact on the lipoprotein profile over 6–12 months.<sup>247</sup> **In summary, studies of low-dose formulations indicate that the adverse effects of progestins are limited to the fixed-dose combination with a dose of levonorgestrel that exceeds that in the multiphasic formulation or in the low-dose products.** The formulation that contains 100 µg levonorgestrel and 20 µg ethinyl estradiol produces short-term changes in the lipid profile that are similar to those seen with other low-dose oral contraceptives, and with long-term use, the levels revert to those observed at baseline before treatment.<sup>248</sup> The effects of transdermal administration have been studied, and it appears triglycerides increase modestly, and the LDL/HDL ratio declines slightly.<sup>249</sup>

An important study in monkeys indicated a protective action of estrogen against atherosclerosis but by a mechanism independent of the cholesterol-lipoprotein profile. Oral administration of a combination of estrogen and progestin to monkeys fed a high-cholesterol, atherogenic diet decreased the extent of coronary atherosclerosis despite a reduction in HDL cholesterol levels.<sup>250,251,252</sup> In somewhat similar experiments, estrogen treatment markedly prevented arterial lesion development in rabbits.<sup>253,254,255</sup> In considering the impact of progestational agents, lowering of HDL is not necessarily atherogenic if accompanied by a significant estrogen impact. The estrogen component provides protection through a direct effect on vessel walls, especially favorably influencing vasomotor and platelet factors such as nitric oxide and prostacyclin.

This conclusion is reinforced by angiographic and autopsy studies. Young women with myocardial infarctions who have used oral contraceptives have less diffuse atherosclerosis than nonusers.<sup>256,257</sup> Indeed, a case-control study indicated that the risk of myocardial infarction in patients taking older, high-dose levonorgestrel-containing formulations is the same as that experienced with pills containing other progestins.<sup>170</sup>

In the past two decades, we were subjected to considerable marketing hype about the importance of the impact of oral contraceptives on the cholesterol-lipoprotein

profile. If indeed certain oral contraceptives had a negative impact on the lipoprotein profile, one would expect to find evidence that atherosclerosis caused an increase in subsequent cardiovascular disease. There is no such evidence. Thus, the mechanism of the cardiovascular complications is undoubtedly a short-term acute mechanism—thrombosis (an estrogen-related effect).

Remember too that the new progestins, because of their reduced androgenicity, predictably do not adversely affect the cholesterol-lipoprotein profile. The estrogen-progestin balance of combined oral contraceptives containing one of the new progestins even promotes favorable lipid changes.<sup>35</sup> Thus, the new formulations have the potential to offer protection against cardiovascular disease, an important consideration as we enter an era of women using oral contraceptives for longer durations and later in life. But one must be cautious regarding the clinical significance of subtle laboratory value changes in the absence of outcome data, and it is unlikely that oral contraceptives will have a clinically meaningful beneficial effect on the incidence of coronary heart disease.



# Hypertension

Oral contraceptive–induced hypertension was observed in approximately 5% of users of higher-dose pills. More recent evidence indicates that small increases in blood pressure can be observed even with 30- $\mu$ g estrogen, monophasic pills, including those containing the new progestins. However, an increased incidence of clinically significant hypertension has not been reported.<sup>258,259,260,261,262,263,264</sup> The lack of clinical hypertension in most studies may be due to the rarity of its occurrence. The Nurses' Health Study observed an increased risk of clinical hypertension in current users of low-dose oral contraceptives, providing an incidence of 41.5 cases per 10,000 women per year.<sup>265</sup> Therefore, an annual assessment of blood pressure is still an important element of clinical surveillance, even when low-dose oral contraceptives are used. Postmenopausal women in the Rancho Bernardo Study who had previously used oral contraceptives (probably high-dose products) had slightly higher (2–4 mm Hg) diastolic blood pressures.<sup>266</sup> Because past users do not demonstrate differences in incidence or risk factors for cardiovascular disease, it is unlikely this blood pressure difference has an important clinical effect.

Variables such as previous toxemia of pregnancy or previous renal disease do not predict whether a woman will develop hypertension on oral contraception.<sup>267</sup> Likewise, women who have developed hypertension on oral contraception are not more predisposed to develop toxemia of pregnancy. Overall, there is no evidence that previous oral contraceptive users have an increased risk of hypertension during a subsequent pregnancy.<sup>268,269</sup> The exception is the Nurses' Health Study, which indicated that recent users for a long duration (8 or more years) have a twofold increased risk of preeclampsia, a finding that was based on a small number of cases.<sup>270</sup> These epidemiologic associations are hard to establish because of the role of underlying hypertension in pregnancy-induced hypertension and the difficulty in assessing the efficacy of hypertension screening in oral contraceptive users.

The mechanism for an effect on blood pressure is thought to involve the renin-angiotensin system. The most consistent finding is a marked increase in plasma angiotensinogen, the renin substrate, up to 8 times normal values (on higher-dose pills). In nearly all women, excessive vasoconstriction is prevented by a compensatory decrease in plasma renin concentration. If hypertension does develop, the renin-angiotensinogen changes take 3–6 months to disappear after stopping combined oral contraception.

Women with treated hypertension using oral contraceptives have been reported to have poor control of blood pressure with higher diastolic pressures.<sup>271</sup> **In our view, with medical control of the blood pressure and close follow-up (at least every 3**

months), the clinician and the nonsmoking patient who is under age 35 and otherwise healthy may choose low-dose oral contraception. Close follow-up is also indicated in women with a history of preexisting renal disease or a strong family history of hypertension or cardiovascular disease. It seems prudent to suggest that patients with marginal cardiac reserve should utilize other means of contraception. Significant increases in cardiac output and plasma volume have been recorded with oral contraceptive use (higher-dose pills), probably a result of fluid retention.

**The epidemiologic data emphasize the importance of good patient screening.** The occurrence of thrombosis is essentially limited to older women who smoke or have cardiovascular risk factors, especially hypertension, or who have an inherited thrombophilia. **If a patient has a close family history (parent or sibling) or a previous episode of idiopathic thromboembolism, an evaluation to search for an underlying abnormality in the coagulation system is warranted.** It has been reported that family history of venous thromboembolism has low predictive value.<sup>272</sup> Another study indicated that testing for thrombophilia did not allow for prediction of recurrent events, but risk factors such as family history did provide prediction.<sup>273</sup> The conservative recommendation for a high-risk woman considering exposure to exogenous estrogen stimulation is to rule out an underlying thrombophilia. The importance of this issue is illustrated by the increased risk of a very rare event, cerebral sinus thrombosis, in women who have an inherited predisposition for clotting and use oral contraceptives.<sup>131,274</sup> When new transdermal contraceptive users are compared with new users of oral contraception, there is no increased or decreased risk of cerebral venous sinus thrombosis.<sup>275</sup>

The following measurements are recommended, and abnormal results require consultation with a hematologist regarding prognosis and prophylactic treatment. The list of laboratory tests is long, and because this is a dynamic and changing field, the best advice is to consult with a hematologist. If a diagnosis of a congenital deficiency is made, screening should be offered to other family members (Table 22.6).

## **TABLE 22.6 Hypercoagulable States**

## Hypercoagulable Conditions

## Thrombophilia Screening

Antithrombin III deficiency

Antithrombin III

Protein C deficiency

Protein C

Protein S deficiency

Protein S

Factor V Leiden mutation

Activated protein C resistance ratio

Prothrombin gene mutation

Activated partial thromboplastin time

Antiphospholipid syndrome

Hexagonal activated partial thromboplastin time

Anticardiolipin antibodies

Lupus anticoagulant

Fibrinogen

Prothrombin G mutation (DNA test)

Thrombin time

Homocysteine level

Complete blood count

**Combination estrogen-progestin contraception is contraindicated in women who have a history of idiopathic venous thromboembolism and also in women who have a close family history (parent or sibling) of idiopathic venous thromboembolism.** These women will have a higher incidence of congenital deficiencies in important clotting measurements, especially antithrombin III, protein C, protein S, and resistance to activated protein C.<sup>276</sup> Such a patient who screens negatively for an inherited clotting deficiency might still consider the use of oral contraceptives, but this would be a difficult decision with unknown risks for both patient and clinician, and it is more prudent to consider other contraceptive options. Other risk factors for thromboembolism that should be considered by clinicians include an acquired predisposition such as the presence of lupus anticoagulant or malignancy and immobility or trauma. Varicose veins are not a risk factor unless they are very extensive.<sup>164</sup> **Progestin-only methods, including implants, depot medroxyprogesterone acetate, and the levonorgestrel-releasing IUS, are recommended for high-risk women and for women who are anticoagulated.**

**The conclusion once again is that low-dose oral contraceptives are very safe for healthy, young women.** By effectively screening older women for the presence of smoking and cardiovascular risk factors, especially hypertension, we can limit, if not eliminate, any increased risk for arterial disease associated with low-dose oral contraceptives. And it is very important to emphasize that there is no increased risk of cardiovascular events associated with duration of use (long-term). In large cohort studies, the risk of overall mortality comparing users and nonusers of oral contraceptives is identical.<sup>160,161,162</sup> It is worth noting again that these conclusions likely also apply to transdermal and vaginal estrogen-progestin contraception.

# Summary: Oral Contraceptives and Cardiovascular Disease

The outpouring of epidemiologic data in the last two decades allows the construction of a clinical formulation that is evidence based. The following conclusions are consistent with the recent reports.

- Pharmacologic estrogen increases the production of clotting factors.
- Progestins have no significant impact on clotting factors.
- Past users of oral contraceptives do not have an increased incidence of cardiovascular disease.
- All low-dose oral contraceptives, regardless of progestin type, have an increased risk of venous thromboembolism, concentrated in the first 1–2 years of use. The actual risk of venous thrombosis with low-dose oral contraceptives is lower in the new studies compared with previous reports. Some have argued that this is due to preferential prescribing and the healthy user effect. However, it is also logical that the lower risk reflects better screening of patients and lower estrogen doses. The risk increases with increasing age and body weight.
- Smoking has a lesser effect on the risk of venous thrombosis compared with arterial thrombosis.
- Smoking and estrogen have an additive effect on the risk of arterial thrombosis. Why is there a difference between venous and arterial clotting? The venous system has low flow with a state of high fibrinogen and low platelets, in contrast to the high-flow state of the arterial system with low fibrinogen and high platelets. Thus, it is understandable why these two different systems can respond in different ways.
- Hypertension is a very important additive risk factor for stroke in oral contraceptive users.
- Low-dose oral contraceptives (<50- $\mu$ g ethinyl estradiol) do not increase the risk of myocardial infarction or stroke in healthy, nonsmoking women, regardless of age.
- Almost all myocardial infarctions and strokes in oral contraceptive users occur in users of high-dose products or users with cardiovascular risk factors over the age of 35. In the Oxford Family Planning Association cohort, cardiac deaths occurred only in women who smoked 15 or more cigarettes per day.<sup>152</sup>
- Arterial thrombosis (myocardial infarction and stroke) has a dose-response relationship with the dose of estrogen, but there are insufficient data to determine whether there is a difference in risk with products that contain 20, 30, or 35  $\mu$ g ethinyl estradiol.

# CARBOHYDRATE METABOLISM

---

With the older high-dose oral contraceptives, an impaired glucose tolerance test was present in many women. In these women, plasma levels of insulin as well as the blood sugar were elevated. Generally, the effect of oral contraception is to produce an increase in peripheral resistance to insulin action. Most women can meet this challenge by increasing insulin secretion, and there is no change in the glucose tolerance test, although 1-hour values may be slightly elevated.

Insulin sensitivity is affected mainly by the progestin component of the pill.<sup>277</sup> The derangement of carbohydrate metabolism may also be affected by estrogen influences on lipid metabolism, hepatic enzymes, and elevation of unbound cortisol. The glucose intolerance is dose-related, and once again effects are less with the low-dose formulations. **Insulin and glucose changes with low-dose monophasic and multiphasic oral contraceptives are so minimal that it is now believed they are of no clinical significance.**<sup>264,278,279,280,281</sup> This includes long-term evaluation with hemoglobin A1c.

The observed changes in studies of oral contraception and carbohydrate metabolism are in the nondiabetic range. In order to measure differences, investigators have resorted to analysis by measuring the area under the curve for glucose and insulin responses during glucose tolerance tests. A highly regarded cross-sectional study utilizing this technique reported that even lower-dose formulations have detectable effects on insulin resistance.<sup>277</sup> The reason this is important is that it is now recognized that hyperinsulinemia due to insulin resistance is a contributor to cardiovascular disease.

Because long-term, follow-up studies of large populations have failed to detect any increase in the incidence of diabetes mellitus or impaired glucose tolerance (even in past and current users of high-dose pills),<sup>265,282,283</sup> the concern now appropriately focuses on the slight impairment as a potential risk for cardiovascular disease. If slight hyperinsulinemia were meaningful, wouldn't you expect to see evidence of an increase in cardiovascular disease in past users who took oral contraceptives when doses were higher? As we have emphasized before, there is no such evidence. The data strongly indicate that the changes in lipids and carbohydrate metabolism that have been measured are not clinically meaningful.

It can be stated definitively that oral contraceptive use does not produce an increase in diabetes mellitus.<sup>282,283,284,285</sup> The minor hyperglycemia associated with oral contraception is not deleterious and is completely reversible. Even women who have risk factors for diabetes in their history are not affected. In women with recent gestational diabetes, no significant impact on glucose tolerance could be demonstrated over 6–13 months comparing the use of low-dose monophasic and multiphasic oral

contraceptives with a control group, and no increase in the risk of overt diabetes mellitus could be detected with long-term follow-up.<sup>286,287</sup> A high percentage of women with previous gestational diabetes develop overt diabetes and associated vascular complications. Until overt diabetes develops, it is appropriate for these patients to use low-dose oral contraception.

In clinical practice, it may, at times, be necessary to prescribe oral contraception for the overt diabetic. No effect on insulin requirement is expected with low-dose pills.<sup>288</sup> Older epidemiologic data suggest oral contraceptives increased the risk of thrombosis in women with insulin-dependent diabetes mellitus; historically, women with diabetes had been encouraged to use other forms of contraception. However, a case-control study could find no evidence that oral contraceptive use by young women with insulin-dependent diabetes mellitus increased the development of retinopathy or nephropathy.<sup>289</sup> In a 1-year study of women with insulin-dependent diabetes mellitus who were using a low-dose oral contraceptive, no deterioration could be documented in lipoprotein or hemostatic biochemical markers for cardiovascular risk.<sup>290</sup> And finally, no effect of oral contraceptives on cardiovascular mortality could be detected in a group of women with diabetes mellitus.<sup>291</sup>

These findings can reasonably be assumed to extend to users of transdermal contraception. Users of the NuvaRing with type 1 diabetes were found to have no change in carbohydrate metabolism.<sup>292</sup>

# THE LIVER

---

The liver is affected in more ways and with more regularity and intensity by the sex steroids than any other extragenital organ. Estrogen influences the synthesis of hepatic cell enzymes, serum enzymes formed in the liver, and plasma proteins. Estrogenic hormones also affect hepatic lipid and lipoprotein formation, the intermediary metabolism of carbohydrates, and intracellular enzyme activity. Nevertheless, an extensive analysis of the prospective cohorts of women in the Royal College of General Practitioners' Oral Contraception Study and the Oxford Family Planning Association Contraceptive Study could detect no evidence of an increased incidence or risk of serious liver disease among oral contraceptive users.<sup>293</sup>

The active transport of biliary components is impaired by estrogens as well as some progestins. The mechanism is unclear, but cholestatic jaundice and pruritus were occasional complications of higher-dose oral contraception and are similar to the recurrent jaundice of pregnancy, that is, benign and reversible. The incidence with lower-dose oral contraception is unknown, but it must be a very rare occurrence.

**The only absolute hepatic contraindication to steroid contraceptive use is acute or chronic cholestatic liver disease. Cirrhosis and previous hepatitis are not aggravated. Once recovered from the acute phase of liver disease (normal enzyme levels), a woman can use steroid contraception.**

Data from the Royal College of General Practitioners' prospective study indicated that an increase in the incidence of gallstones occurred in the first years of oral contraceptive use, apparently due to an acceleration of gallbladder disease in women already susceptible.<sup>294</sup> In other words, the overall risk of gallbladder disease was not increased, but in the first years of use, disease was activated or accelerated in women who were vulnerable because of asymptomatic disease or a tendency toward gallbladder disease. The mechanism appears to be induced alterations in the composition of gallbladder bile, specifically a rise in cholesterol saturation that is presumably an estrogen effect.<sup>295</sup> The Nurses' Health Study reported no significant increase in the risk of symptomatic gallstones among ever users but slightly elevated risks among current and long-term users.<sup>296</sup> Although oral contraceptive use has been linked to an increased risk of gallbladder disease, the epidemiologic evidence has been inconsistent. Indeed, an Italian case-control study and a report from the Oxford Family Planning Association cohort found no increase in the risk of gallbladder disease in association with oral contraceptive use and no interaction with increasing age or body weight.<sup>297,298</sup> Keep in mind that even though some studies found a statistically significant modest increase in the relative risk of gallbladder disease, even if the effect were real, it is of little clinical importance because the actual incidence of this problem



is very low.

# Liver Adenomas

Hepatocellular adenomas can be produced by steroids of both the estrogen and androgen families. Actually, there are several different lesions: peliosis, focal nodular hyperplasia, and adenomas. Peliosis is characterized by dilated vascular spaces without endothelial lining and may occur in the absence of adenomatous changes. The adenomas are not malignant; their significance lies in the potential for hemorrhage. The most common presentation is acute right upper quadrant or epigastric pain. The tumors may be asymptomatic, or they may present suddenly with hemoperitoneum. There is some evidence that the tumors and focal nodular hyperplasia regress when oral contraception is stopped.<sup>299,300</sup> Epidemiologic data have not supported the contention that mestranol increased the risk more than ethinyl estradiol.

The risk appears to be related to duration of oral contraceptive use and to the steroid dose in the pills. This is reinforced by the rarity of the condition ever since low-dose oral contraception became available. The ongoing prospective studies have accumulated many woman-years of use and have not identified an increased incidence of such tumors.<sup>293</sup> In a collaborative study of 15 German liver centers, no increase in risk for liver adenomas in contemporary oral contraceptive users could be detected.<sup>301</sup> An Italian case-control study found an increase in risk for focal nodular hyperplasia associated with low-dose oral contraceptives, a risk that reached statistical significance only with 3 or more years of use (with a very wide confidence interval because of only 13 cases).<sup>302</sup> In our view, it is not necessary to discuss liver problems during the informed consent process.

No reliable screening test or procedure is currently available for the detection of liver adenomas. Routine liver function tests are normal. Computed tomography (CT) scanning or magnetic resonance imaging (MRI) is the best means of diagnosis; angiography and ultrasonography are not reliable. Palpation of the liver should be part of the periodic evaluation in oral contraceptive users. If an enlarged liver is found, oral contraception should be stopped, and regression should be evaluated and followed by imaging.

## OTHER METABOLIC EFFECTS

---

Nausea and breast discomfort continue to be disturbing effects, but their incidence is significantly less with low-dose oral contraception. Fortunately, these effects are most intense in the first few months of use and, in most cases, gradually disappear. In placebo-controlled trials with low-dose oral contraceptives, the incidence of “minor” side effects such as headache, nausea, dysmenorrhea, and breast discomfort actually occurred at the same rate in the treated group and the placebo group!<sup>303,304,305</sup> Weight gain usually responds to dietary restriction, but for some patients, the weight gain is an anabolic response to the sex steroids, and discontinuation of oral contraception is the only way that weight loss can be achieved. This must be rare with low-dose oral contraception because data in published studies, especially in placebo-controlled trials, fail to indicate a difference in body weight between users and nonusers.<sup>305,306,307,308,309,310,311,312,313</sup>

There is no association between oral contraception and peptic ulcer disease or inflammatory bowel disease.<sup>314,315</sup> Oral contraception is not recommended for patients with problems of gastrointestinal malabsorption because of the possibility of contraceptive failure, although vaginal administration would be appropriate.

Chloasma, a patchy increase in facial pigment, was, at one time, found to occur in approximately 10% of oral contraceptive users. It is now a rare problem due to the decrease in estrogen dose. Unfortunately, once chloasma appears, it fades only gradually following discontinuation of the pill and may never disappear completely. Skin-blanching medications may be useful.<sup>316</sup>

Hematologic effects include an increased sedimentation rate, an increased total iron-binding capacity due to the increase in globulins, and a decrease in prothrombin time. The use of hormonal contraceptives results in a decrease in iron deficiency anemia because of a reduction in menstrual bleeding.<sup>317,318</sup> Indeed, in anemic women, an increase in hemoglobin and ferritin levels accompanies the use of oral contraceptives.<sup>319</sup>

The continuous, daily use of oral contraceptives may prevent the appearance of symptoms in porphyria precipitated by menses. Changes in vitamin metabolism have been noted: a small nonharmful increase in vitamin A and decreases in blood levels of pyridoxine (B<sub>6</sub>) and the other B vitamins, folic acid, and ascorbic acid. Despite these changes, routine vitamin supplements are not necessary for women eating adequate, normal diets.<sup>320</sup>

# MENTAL HEALTH AND MOOD

---

The relationship between hormonal contraception and mental health has been debated in the literature. Two recent reviews out of Denmark recently posit a relationship between first-time hormonal contraception use and receiving a prescription for an antidepressant and, more concerning, an increased risk of suicide and suicide attempt in young women.<sup>321,322</sup> These studies use women not on any contraception as the comparator group, and it has been argued that this could introduce selection bias, and women who began nonhormonal contraception would be more accurate. A review in the United States focusing on sexually active women using hormonal contraception, nonhormonal contraception, or no contraception found no differences between the groups for most ages and a decrease in depressive symptoms and reported suicide attempt in the past year with women on hormonal contraception.<sup>323</sup> A cross-sectional study found no evidence for increased symptoms of depression or anxiety among users of the oral contraceptive pills among women aged 18–54.<sup>324</sup> Systematic review articles show mental depression is not associated with progestin-only oral contraceptives and that hormonal contraception does not worsen symptoms of depression and is in fact associated with an improvement in depressive symptoms in the adolescent population.<sup>325,326</sup> A review article on combined hormonal contraception and mood posited that no conclusions could be made due to a lack of prospective data on this subject, but the current literature suggests that most women using combined hormonal contraception have little noticeable effect on mood.<sup>327</sup> A randomized controlled study looking on mood fluctuations within a single menstrual cycle reported that women taking combined hormonal contraceptives actually reported significantly less depression in the intermenstrual phase than women on placebo.<sup>328</sup>

Though infrequent, a reduction in libido is occasionally a problem and may be a cause for seeking an alternative method of contraception.<sup>329</sup> Indeed, most women report an increase or no change in libido during oral contraceptive use.<sup>330,331</sup> Nevertheless, the estrogen-induced increase in SHBG and the resulting decrease in free testosterone may produce an impact on sexuality in some women. An empiric trial of a non-estrogen-containing contraceptive method is warranted.

Adverse androgenic voice changes were occasionally encountered with the use of the first very-high-dose oral contraceptives. Vocal virilization can be a serious and devastating problem for some women, especially when vocal performance is important. Careful study of women on low-dose oral contraceptives indicates that this is no longer a side effect of concern.<sup>332</sup>

# **THE RISK OF CANCER**

---

# Endometrial Cancer

The use of oral contraception protects against endometrial cancer. The use for at least 12 months reduces the risk of developing endometrial cancer by **50%**, with the greatest protective effect gained by use for more than 3 years.<sup>333,334,335,336,337,338</sup> This protection persists for 20 or more years after discontinuation (the actual length of duration of protection is unknown) and is greatest in women at highest risk: nulliparous and low-parity women.<sup>338,339</sup> This protection is equally protective for all three major histologic subtypes of endometrial cancer: adenocarcinoma, adenoacanthoma, and adenosquamous cancers. Finally, protection is seen with all monophasic formulations of oral contraceptives, including pills with less than 50 µg estrogen.<sup>332,335,338,340</sup> There are no data as yet with multiphasic preparations or the new progestin formulations, but because these products are still dominated by their progestational component, there is every reason to believe that they will be protective.

# Ovarian Cancer

Protection against ovarian cancer, the most lethal of female reproductive tract cancers, is one of the most important benefits of oral contraception. Because this cancer is detected late and prognosis is poor, the impact of this protection is very significant. Indeed, a decline in mortality from ovarian cancer has been observed in several countries since the early 1970s, perhaps an effect of oral contraceptive use.<sup>341</sup> Women with increased exposure to oral contraceptives have demonstrated a marked decrease in the incidence of ovarian cancer.<sup>342,343,344,345</sup> The risk of developing epithelial ovarian cancer of all histologic subtypes in users of oral contraception is reduced by **40%** compared with that of nonusers.<sup>335,337,346,347,348,349,350,351,352</sup> This protective effect increases with duration of use and continues for at least 20 years after stopping the medication.<sup>353</sup> This protection is seen in women who use oral contraception for 3 years or more, reaching an 80% reduction in risk with more than 10 years of use, and is a benefit associated with all monophasic formulations, including the low-dose products.<sup>350,351,352,354</sup> The protective effect of oral contraceptives is especially observed in women at high risk of ovarian cancer (nulliparous women and women with a positive family history).<sup>355,356</sup> Continuous use of oral contraception for 10 years by women with a positive family history for ovarian cancer can reduce the risk of epithelial ovarian cancer to a level equal to or less than that experienced by women with a negative family history.<sup>355</sup> Again, the multiphasic and new progestin products have not been in use long enough to yield any data on this issue, but because ovulation is effectively inhibited by these formulations, protection against ovarian cancer should be exerted. **The same magnitude of protection has been observed in women with BRCA1 or BRCA2 mutations.**<sup>357,358,359</sup>

# Cancer of the Cervix

Studies have indicated that the risk for dysplasia and carcinoma in situ of the uterine cervix increases with the use of oral contraception for more than 1 year.<sup>360,361,362,363,364,365</sup> Invasive cervical cancer may be increased after 5 years of use, reaching a twofold increase after 10 years. It is well recognized, however, that the number of partners a woman has had and age at first coitus are important risk factors for cervical neoplasia. Other confounding factors include exposure to human papillomavirus (HPV), receiving the human papillomavirus vaccine (protective), the use of barrier contraception (protective), and smoking.<sup>366</sup> It has been well-demonstrated that oral contraceptive users have more sexual partners, more HPV infections, and more Pap smears. These are difficult factors to control, and, therefore, the conclusions regarding cervical cancer are not definitive. An excellent study from the Centers for Disease Control and Prevention (CDC) concluded there is no increased risk of invasive cervical cancer in users of oral contraception, and an apparent increased risk of carcinoma in situ is due to enhanced detection of disease (because oral contraceptive users have more frequent Pap smears).<sup>363</sup> In the World Health Organization Study of Neoplasia and Steroid Contraceptives, a Pap smear screening bias was identified; nevertheless, the evidence still suggested an increased risk of cervical carcinoma in situ with long-term oral contraceptive use.<sup>364</sup> The UK Royal College of General Practitioners completed a study with 44 years of follow-up and noted that while in the first 5 years of oral contraceptive use there was an increase in detection of cervical cancer, the risk of cervical cancer balanced with nonusers over time.<sup>365</sup>

A case-control study of patients in Panama, Costa Rica, Colombia, and Mexico concluded that there was a significantly increased risk for invasive adenocarcinoma.<sup>367</sup> Similar results were obtained in a case-control study in Los Angeles and in the World Health Organization Collaborative Study.<sup>368,369</sup> In Los Angeles, the relative risk of adenocarcinoma of the cervix increased from 2.1 with ever use to 4.4 with 12 or more years of oral contraceptive use.<sup>368</sup> Oral contraceptives increase cervical ectopia, but whether this increases the risk of cervical adenocarcinoma is unclear.

A large meta-analysis concluded that the relative risk of cervical cancer increased with increasing duration of use (for in situ and invasive cancer and both squamous cancer and adenocarcinoma); however, the risk was confined to the cases who tested positively for HPV.<sup>370</sup> A pooled analysis of case-control studies concluded that the risk of cervical cancer in women with HPV increases about threefold but not until after 5 years of use.<sup>371</sup>

A meta-analysis of 24 epidemiologic studies included 16,573 women with cervical



cancer and 35,509 women without cervical cancer.<sup>372</sup> The risk of cervical cancer in situ and invasive cancer increased about twofold with increasing duration of use of oral contraceptives. After discontinuation of oral contraceptives, the risk steadily declined. There was no increase in risk with duration of use less than 5 years or after 10 or more years since last use. The same relationships were seen comparing women likely to have been screened and those likely not to have been screened. Although the numbers were smaller, women who were positive for HPV demonstrated the same pattern of risk. Additionally, a greater incidence of smoking in oral contraceptive users was noted.

We currently know three important facts about cervical cancer. (1) Cervical cancer is caused by HPV. (2) Cervical cancer is reduced in prevalence by Pap smear screening. (3) HPV vaccination can potentially eliminate most cases of cervical cancer. Oral contraceptive users have behavior patterns that place them at greater risk of HPV infections. In addition, oral contraceptives could increase the ability of HPV to establish itself in the cervix. Once infected with HPV, oral contraceptives could influence the response of a woman to HPV, for example, suppressing the immune response. Therefore, we don't know for certain whether case-control and cohort data reflect an enhancing effect of oral contraceptives on the risk of cervical cancer or whether the results are affected by the confounding problems of HPV infections and the prevalence of Pap smear screening.

These studies reinforce the HPV and Pap smear screening that we already support and provide another argument in favor of HPV vaccination. The liquid-based methods along with HPV DNA testing will provide even better identification of at-risk women. Fortunately, steroid contraception does not mask abnormal cervical changes, and the necessity for prescription renewals offers the opportunity for improved screening for cervical disease. **Pap smear guidelines from the American Society for Colposcopy and Cervical Pathology should be followed.** Oral contraceptive use is appropriate for women with a history of cervical intraepithelial neoplasia (CIN), including those who have been surgically treated.

# Liver Cancer

Oral contraception has been linked to the development of hepatocellular carcinoma.<sup>373,374</sup> However, the very small number of cases, and, thus, the limited statistical power, requires great caution in interpretation. The largest study on this question, the WHO Collaborative Study of Neoplasia and Steroid Contraceptives, found no association between oral contraception and liver cancer.<sup>375</sup> Even case-control analysis of oral contraceptives containing cyproterone acetate (known to be toxic to the liver in high doses) could detect no evidence of an increased risk of liver cancer.<sup>376</sup> In the United States, Japan, Sweden, England, and Wales, the death rates from liver cancer did not change despite introduction and use of oral contraception.<sup>377,378</sup> More recently, there has been an increase in liver cancer incidence and mortality in the United States, but this is believed to be due to infection with hepatitis C and hepatitis B.<sup>379</sup>

# Breast Cancer

Because of breast cancer's prevalence and its long latent phase, concern over the relationship between oral contraception and breast cancer continues to be an issue in the minds of both patients and clinicians. Risk of developing breast cancer with hormonal contraception in the general population and in BRCA gene mutation carriers is discussed in full in [Chapter 16](#). This subject has been studied extensively, and the results of the studies are not clear-cut. Some studies have indicated an overall increased relative risk of early, premenopausal breast cancer,<sup>380,381,382,383,384,385,386,387,388,389,390,391,392,393,394,395,396,397,398,399</sup> while others indicated no increase in overall risk.<sup>400,401,402</sup> The most impressive finding indicates a link in most studies,<sup>393,394,395,396,397,398,399,400,401,402</sup> but not all,<sup>403,404,405,406,407</sup> of early breast cancer before age 40 with women who used oral contraception for long durations of time. The evidence seems stronger for a relationship with time since last use, an elevated risk being significant for current users and in women who had stopped use 1–4 years before (recent use).

Overall, this massive statistical exercise yielded good news. No major adverse impact of oral contraceptives emerged. **Even though the data indicated that young women who begin use before age 20 have higher relative risks of breast cancer during current use and in the 5 years after stopping, this is a time period when breast cancer is very rare, and, thus, there would be little impact on the actual number of breast cancers.** The difference between localized disease and metastatic disease was statistically greater and should be observable. Thus, many years after stopping oral contraceptive use, the main effect may be protection against metastatic disease. Breast cancer is more common in older years, and 10 or more years after stopping, the risk was not increased.

What explanation could account for an increased risk associated only with current or recent use, no increase with duration of use, and a return to normal 10 years after exposure? The slightly increased risk could be influenced by detection/surveillance bias (more interaction with the health care system by oral contraceptive users). It is also possible that this situation is analogous to that of pregnancy. Studies indicate that pregnancy transiently increases the risk of breast cancer (for a period of several years) after a woman's first childbirth, and this is followed by a lifetime reduction in risk.<sup>408</sup> And some have found that a concurrent or recent pregnancy adversely affects survival.<sup>409,410</sup> It is argued that breast cells that have already begun malignant transformation are adversely affected by the hormones of pregnancy, while normal stem cells become more resistant because of a pregnancy. It is possible that early and recent use of oral contraceptives also affects the growth of a preexisting malignancy,

explaining the limitation of the finding to current and recent use and the increase in localized disease.

For women who are BRCA positive, the research results are similarly confusing. A case-control study concluded that BRCA1 mutation carriers had small increases in the risk of breast cancer in users for at least 5 years, in users before age 30, and in those who developed breast cancer before age 40.<sup>411</sup> In contrast, another case-control study concluded that oral contraceptive use for at least 5 years doubled the risk of breast cancer before age 50 in BRCA2 carriers, but not in BRCA1 carriers.<sup>412</sup> A retrospective analysis of an international cohort of BRCA carriers indicated that an increased risk of breast cancer with both BRCA1 and BRCA2 carriers was present only with 4 or more years of use before a first full-term pregnancy.<sup>413</sup> A study that focused on low-dose oral contraceptives could detect no association with breast cancer risk in BRCA mutation carriers.<sup>414</sup> Another case-control study found no increase in the risk of breast cancer diagnosed before age 40 in either BRCA1 or BRCA2 carriers.<sup>415</sup> And finally, a case-control study could detect no significant increase in the risk of contralateral breast cancer among BRCA1 and BRCA2 carriers or in noncarriers.<sup>416</sup> The data with oral contraceptives in BRCA mutation carriers (also discussed in [Chapter 16](#)) are all observational and not robust. **Until better information is forthcoming, it seems reasonable to inform carriers of BRCA mutations that the use of oral contraceptives is likely to reduce the risk of ovarian cancer, but the effect on breast cancer risk is uncertain.**

A team of epidemiologists from several institutions in the United States performed a case-control study of the association between oral contraceptive use and lobular and ductal breast cancer occurring in young women (under age 44) and found that use of oral contraceptives has no effect on breast cancer histologic subtype.<sup>416</sup>

Even if there is a small increase in premenopausal breast cancer associated with oral contraceptives, this would be a very small number of cases because most cases of breast cancer occur after age 40. Well-done and large case-control studies of modern low-dose oral contraceptives have been consistently negative and reassuring.

# Colorectal Cancer

The Nurses' Health Study reported about a 40% reduced risk of colorectal cancer associated with 8 years of previous use of oral contraceptives.<sup>417</sup> A meta-analysis of published studies concluded that there is an 18% reduction in risk of colorectal cancer in ever users of oral contraception, with a stronger effect in recent users.<sup>418</sup> Both case-control and cohort studies have reported reductions in the risk of colorectal cancer associated with the ever use of oral contraceptives.<sup>419,420,421</sup> **Steroid contraception should be offered to women with a strong family history of colorectal cancer.**

## Other Cancers

The major risk factor for melanoma is exposure to sunlight, but there are previous reports of an association with hormonal contraception use. More accurate evaluation utilizing both the Royal College General Practitioners and Oxford Family Planning Association prospective cohorts and accounting for exposure to sunlight did not indicate a significant difference in the risk of melanoma comparing users to nonusers.<sup>422,423,424</sup> There is no evidence linking oral contraceptive use to kidney cancer, gallbladder cancer, or pituitary tumors.<sup>425</sup> Long-term oral contraceptive use may slightly increase the risk of molar pregnancy.<sup>426,427,428</sup> A case-control study concluded that oral contraceptives reduce the risk of salivary gland cancer.<sup>429</sup>

# Summary: Oral Contraceptives and the Risk of Breast Cancer

- Current and recent use of oral contraceptives may be associated with a slightly increased risk of early premenopausal breast cancer. This finding may be due to detection/surveillance bias and accelerated growth of already-present malignancies, a situation similar to the effects of pregnancy and postmenopausal hormone therapy on the risk of breast cancer (as reviewed in [Chapter 18](#)).
- There is no effect of past use or duration of oral contraceptive use (up to 15 years of continuous use) on the risk of breast cancer, and there is no evidence indicating that higher-dose oral contraceptives increased the risk of breast cancer.
- Previous oral contraceptive use may be associated with a reduced risk of metastatic breast cancer later in life and possibly with a reduced risk of postmenopausal breast cancer.
- Oral contraceptive use does not further increase the risk of breast cancer in women with positive family histories of breast cancer or in women with proven benign breast disease.
- The clinician should not fail to take every opportunity to direct attention to all factors that affect breast cancer. Breast-feeding and control of alcohol intake are good examples and are also components of preventive health care. Especially important is this added motivation to encourage breast-feeding. The protective effect of breast-feeding is exerted (although it is probably a small one, see [Chapter 16](#)) mainly on premenopausal breast cancer, the cancer of concern to younger women using oral contraception.

# **ENDOCRINE EFFECTS**

---



# Adrenal Gland

Estrogen increases the cortisol-binding globulin (CBG). It had been thought that the increase in plasma cortisol while on oral contraception was due to increased binding by this globulin and not an increase in free active cortisol. Now it is apparent that free and active cortisol levels are also elevated, but only slightly.<sup>430</sup> Estrogen decreases the ability of the liver to metabolize cortisol, and in addition, progesterone and related compounds can displace cortisol from transcortin and thus contribute to the elevation of unbound cortisol. The effects of these elevated levels over prolonged periods of time are unknown, but no obvious impact has become apparent. To put this into perspective, the increase is not as great as that which occurs in pregnancy, and, in fact, it is within the normal range for nonpregnant women.

The adrenal gland responds to adrenocorticotrophic hormone (ACTH) normally in women on oral contraceptives; therefore, there is no suppression of the adrenal gland itself. Initial studies indicated that the response to metyrapone (an  $11\beta$ -hydroxylase blocker) was abnormal, suggesting that the pituitary was suppressed. However, estrogen accelerates the conjugation of metyrapone by the liver, and, therefore, the drug has less effect, thus explaining the subnormal responses initially reported. The pituitary-adrenal reaction to stress is normal in women on oral contraceptive pills.

# Thyroid

Estrogen increases the synthesis and circulating levels of thyroxine-binding globulin. Prior to the introduction of methods for measuring free thyroxine levels, evaluation of thyroid function was a problem. Measurement of TSH (thyroid-stimulating hormone) and the free thyroxine level in a woman on oral contraception provide an accurate assessment of a patient's thyroid state. Oral contraception affects the total thyroxine level in the blood as well as the amount of binding globulin, but the free thyroxine level is unchanged.<sup>430</sup>

# **ORAL                      CONTRACEPTION                      AND REPRODUCTION**

---

The impact of oral contraceptives on the reproductive system is less than initially thought. Early studies that indicated adverse effects have not stood the test of time and the scrutiny of multiple, careful studies. There are two major areas that warrant review: (1) inadvertent use of oral contraceptives during the cycle of conception and during early pregnancy and (2) reproduction after discontinuing oral contraception.

# Inadvertent Use During the Cycle of Conception and During Early Pregnancy

One of the reasons, if not the major reason, why a lack of withdrawal bleeding while using oral contraceptives is such a problem is the anxiety produced in both patient and clinician. The patient is anxious because of the uncertainty regarding pregnancy, and the clinician is anxious because of the concerns stemming from the retrospective studies that indicated an increased risk of congenital malformations among the offspring of women who were pregnant and using oral contraception. Organogenesis does not occur in the first 2 embryonic weeks (first 4 weeks since last menstrual period); however, teratogenic effects are possible between the 3rd and 8th embryonic weeks (5–10 weeks since the last menstrual period).

Initial positive reports linking the use of contraceptive steroids to congenital malformations have not been substantiated. Many suspect a strong component of recall bias in the few positive studies due to a tendency of patients with malformed infants to recall details better than those with normal children. Other confounding problems have included a failure to consider the reasons for the administration of hormones (e.g., bleeding in an already abnormal pregnancy) and a failure to delineate the exact timing of the treatment (e.g., treatment was sometimes confined to a period of time during which the heart could not have been affected).

An association with cardiac anomalies was first claimed in the 1970s.<sup>431,432</sup> This link received considerable support with a report from the U.S. Collaborative Perinatal Project; however, subsequent analysis of these data uncovered several methodologic shortcomings.<sup>433</sup> A very thorough and critical review concluded that there was no reliable evidence implicating sex steroids as cardiac teratogens.<sup>434</sup> In fact, no relationship was found between oral contraception and the following problems: hypospadias, limb reduction anomalies, neural tube defects, and mutagenic effects that would be responsible for chromosomally abnormal fetuses. Even virilization is not a practical consideration because the doses required (e.g., 20–40 mg norethindrone per day) are in excess of anything currently used. These conclusions reflect the use of combined oral contraceptives as well as progestins alone.

In the past, there was a concern regarding the VACTERL complex. VACTERL refers to a complex of vertebral, anal, cardiac, tracheoesophageal, renal, and limb anomalies. While case-control studies indicated a relationship with oral contraception, prospective studies have failed to observe any connection between sex steroids and the VACTERL complex.<sup>435</sup> Meta-analyses of the studies of the risk of birth defects with oral contraceptive ingestion during pregnancy concluded that there was no increase in risk for major malformations, congenital heart defects, or limb reduction defects.<sup>436,437</sup>

Women who become pregnant while taking oral contraceptives or women who inadvertently take birth control pills early in pregnancy should be advised that the risk of a significant congenital anomaly is no greater than the general rate of 2–3%. This recommendation can be extended to those pregnant women who have been exposed to a progestational agent such as medroxyprogesterone acetate or 17-hydroxyprogesterone caproate.<sup>438,439</sup>

# Reproduction After Discontinuing Oral Contraception

## Fertility

There may be a mild delay in return to fertility after taking hormonal contraceptives. Initial analysis indicated that a delay was concentrated in women aged 30–34 who had never given birth.<sup>440</sup> At 48 months, 82% of these women had given birth compared with a similar 89% of users of other contraceptive methods. No effect was observed in women younger than 30 or in women who had previously given birth. Childless women aged 25–29 experienced some delay in return to fertility, but by 48 months, 91% had given birth compared with 92% in users of other methods.

This delay was observed in the United States as well. In the Boston area, the interval from cessation of contraception to conception was 13 months or greater for 24.8% of prior oral contraceptive users compared with 10.6% for former users of all other methods (12.4% for intrauterine device, IUD, users, 8.5% for diaphragm uses, and 11.9% for other methods).<sup>441</sup> Oral contraceptive users had a lower monthly percentage of conceptions for the first 3 months and somewhat lower percentage from 4 to 10 months. It took 24 months for 90% of previous oral contraceptive users to become pregnant, 14 months for IUD users, and 10 months for diaphragm users. Similar findings in Connecticut indicated that this delay lasted at least a year, and the effect was greater with higher-dose preparations.<sup>442</sup> Despite the possibility of a delay, there is no evidence that infertility is increased by the use of oral contraception. In fact, in young women, previous oral contraceptive use is associated with a lower risk of primary infertility.<sup>443</sup> Furthermore, the studies indicating a delay in conception are influenced by older, higher-dose products. In a prospective study from the United Kingdom reflecting modern, low-dose oral contraceptives, no delay to conception was found, and long-term use was actually associated with greater fertility.<sup>444</sup> The European Active Surveillance Study on Oral Contraceptives was a prospective cohort study of 59,510 users of low-dose oral contraception. The early and 1-year pregnancy rates after discontinuation of oral contraceptives were not negatively affected, regardless of progestin type, duration of use, or parity.<sup>445</sup> After 2 years, the pregnancy rate was 88.3% and the average time to pregnancy was 5.5 cycles. The previous reports indicating a delay in achieving pregnancy may have been influenced not only by higher-dose products but also by a failure to account for declining fertility with aging and the prescribing of oral contraceptives to women with anovulatory, irregular menstrual periods. **It is unlikely that women discontinuing low-dose steroid contraception experience any significant delay in achieving pregnancy compared with the experience in a general**

**population.**

# Spontaneous Miscarriage

There is no increase in the incidence of spontaneous miscarriage in pregnancies after the cessation of oral contraception. Indeed, the rate of spontaneous miscarriages and stillbirths is slightly less in former pill users, about 1% less for spontaneous miscarriages and 0.3% less for stillbirths.<sup>446</sup> A protective effect of previous oral contraceptive use against spontaneous miscarriage has been observed to be more apparent in women who become pregnant after age 30.<sup>447</sup>



# Pregnancy Outcome

There is no evidence that oral contraceptives cause changes in germ cells that would yield an abnormal child at a later time.<sup>436</sup> There is no increase in the number of abnormal children born to former oral contraceptive users, and there is no change in the sex ratio (a sign of sex-linked recessive mutations).<sup>446,448</sup> These observations are not altered when analyzed for duration of use. Initial observations that women who had previously used oral contraception had an increase in chromosomally abnormal fetuses have not been confirmed. Furthermore, as noted above, there is no increase in the miscarriage rate after discontinuation, something one would expect if oral contraceptives induce chromosomal abnormalities because these are the principal cause of spontaneous miscarriage.

In a 3-year follow-up of children whose mothers used oral contraceptives prior to conception, no differences could be detected in weight, anemia, intelligence, or development.<sup>449</sup> Former pill users have no increased risks for the following: perinatal morbidity or mortality, prematurity, and low birth weight.<sup>450,451</sup> Dizygous twinning has been observed to be nearly twofold (1.6% vs. 1.0%), increased in women who conceive soon after cessation of oral contraception.<sup>446</sup> This effect was greater with longer duration of use.

The only reason (and it is a good one) to recommend that women defer attempts to conceive for a month or two after stopping the pill is to improve the accuracy of gestational dating by allowing accurate identification of the last menstrual period.

# INITIATION OF ORAL CONTRACEPTION IN THE POSTPARTUM PERIOD

---

The 6-week postpartum visit is an anachronism. It is rooted in old texts and teachings from a time when infection was prevalent and before modern methods of contraception were available. The 6-week visit and pelvic examination were based on the understanding that a 6-week period of time would result in sufficient involution of the changes of pregnancy to allow an effective examination that would establish the return of normal pelvic anatomy. These concepts are antiquated. Many women resume sexual activity before the 6th postpartum week, and because ovulation frequently returns before 6 weeks, the obstetrical tradition of scheduling the postpartum visit at 6 weeks should be changed. A 3-week visit would be more effective in avoiding postpartum surprises, preventing postpartum conception by earlier initiation of effective contraception. There is no reason why a complete physical examination cannot be deferred in an asymptomatic woman until the 3-month follow-up visit that is part of good contraceptive care.

# Postpartum Return of Ovulation in Non–Breast-Feeding Women

In non–breast-feeding women, gonadotropin levels remain low during the early puerperium and return to normal concentrations during the 3rd to 5th week when prolactin levels have returned to baseline. In a careful study of 22 women, not one woman ovulated before 25 days after delivery, but 11 ovulated before the 6th postpartum week.<sup>452,453</sup> In addition, two-thirds of the women ovulated before their first menses. **Non–breast-feeding women, therefore, begin to ovulate after 3 postpartum weeks, and the return of menses cannot be used as an indicator.**

# The Contraceptive Effect of Lactation

In primitive human societies, the duration of the birth interval was very important for the survival of the young. Throughout human history, no preliterate society achieved a fertility rate at the maximal level possible. The hunter-gatherer, nomadic Kung women had a high suckling frequency and gave birth about every 4 years.<sup>454</sup> Lactational amenorrhea, lasting up to 2 years, has been nature's most effective form of contraception.<sup>455</sup> Indeed, lactation is the mechanism that maintains a reasonable interval between pregnancies in all nonseasonally breeding animals. In Africa and Asia, breast-feeding reduces the fertility rate by an average of about 30%.<sup>456</sup> Birth intervals of less than 2 years are associated with a greater incidence of low birth weight, preterm birth, and neonatal death for the new infant and malnutrition, infection, and increased 2nd-year mortality for the previous child.<sup>457</sup>

The contraceptive effectiveness of lactation, that is, the length of the interval between births, depends on the level of nutrition of the mother, the intensity of suckling, and the extent to which supplemental food is added to the infant diet. Well-nourished and undernourished women resume ovulating at the same time postpartum.<sup>458</sup>

Amenorrheic women who exclusively breast-feed (full breast-feeding) at regular intervals, including nighttime, during the first 6 months postpartum have the contraceptive protection equivalent to that provided by oral contraception (98% efficacy), but with menstruation or after 6 months, the chance of ovulation increases.<sup>453,459</sup> With full or nearly full breast-feeding, approximately 70% of women remain amenorrheic through 6 months and only 37% through 1 year; nevertheless, with exclusive breast-feeding, the contraceptive efficacy at 1 year is high, about 92%.<sup>460</sup> Fully breast-feeding women commonly have some vaginal bleeding or spotting in the first 8 postpartum weeks, but this bleeding is not due to ovulation.<sup>461</sup> Half of women studied who are not fully breast-feeding ovulate before the 6th week. Lactation, therefore, provides a contraceptive effect, but it is variable and not reliable for every woman.

Prolactin concentrations are increased in response to the repeated suckling stimulus of breast-feeding. Given sufficient intensity and frequency, prolactin levels will remain elevated. Under these conditions, FSH concentrations are in the low-normal range (having risen from extremely low concentrations at delivery to follicular range in the 3 weeks postpartum), and LH values are also in the low-normal range. These low levels of gonadotropins do not allow the ovary during lactational hyperprolactinemia to display follicular development and secrete estrogen. Therefore, vaginal dryness and dyspareunia are commonly reported by breast-feeding women. **The use of vaginal estrogen preparations is discouraged because absorption of the estrogen can lead**

**to inhibition of milk production. Vaginal lubricants should be used until ovarian function and estrogen production return.**

# The Return of Ovulation in Breast-Feeding Women

The return of ovulation in breast-feeding women has been documented in women from all parts of the world. In Chile, 14% of women ovulated during full breast-feeding, although full nursing provided effective contraception up to 3 months postpartum.<sup>461,462</sup> It has been argued that the threshold for suppression of ovulation is at least five feedings for a total of at least 65 min/day suckling duration.<sup>463</sup> However, in the studies from Chile, the frequency of nursing was the same in breast-feeders who ovulated and those who did not.

In Mexico, a study of 29 breast-feeding mothers and 10 non-breast-feeders observed that in the absence of bleeding and supplementary feedings, 100% of the breast-feeders remained anovulatory for 3 months postpartum and 96% up to 6 months.<sup>464</sup> The median time from delivery to first ovulation was 259 days for breast-feeders compared to 119 days for non-breast-feeders. However, by the 3rd postpartum month, 18% of the breast-feeders had ovulated.

In a well-nourished population in Australia, less than 20% of breast-feeding women ovulated by the 6th postpartum month, and less than 25% menstruated.<sup>465</sup> Neither time of first supplement nor the amount of supplement predicted the return of ovulation or menstruation. In other words, even in women giving their infants supplemental feedings, there is effective inhibition of ovulation during the first 6 months of breast-feeding.

# THE POSTPARTUM RISK OF PREGNANCY

---

All too often, writers have emphasized that many couples do not resume sexual intercourse before the 6th postpartum week. What should be emphasized is that longitudinal surveys indicate that impressive numbers do. In England, about one-third of primiparous women resumed intercourse by 6 weeks, and nearly everyone by 3 months.<sup>466</sup> A random survey of all women who delivered in the Grampian region of Scotland in 1990–1991 revealed that 71% had experienced intercourse by 8 weeks postpartum, most by 5 weeks.<sup>467</sup> In another longitudinal follow-up study, nearly 60% of women had resumed intercourse **within** 6 weeks after birth.<sup>468</sup> In North Carolina, 57% of women resumed intercourse by the 6th postpartum week.<sup>469</sup> In Thailand, 35% of women reported resumption of sexual activity before the 6th postpartum week, and no differences were noted comparing vaginal or cesarean deliveries or with and without episiotomies.<sup>470</sup> Breast-feeding in a Canadian study was found to be associated with earlier, not later, resumption of intercourse.<sup>471</sup> In an English study, 166 of 328 women had resumed sexual intercourse, most before the 6th postpartum week, and only 55 of the 166 sexually active women recalled medical and nursing advice regarding resumption of sexual activity.<sup>472</sup> In Nigeria, 32% of breast-feeding mothers resumed sexual activity by 6 weeks postpartum, but only 5% began a method of contraception.<sup>473</sup>

In Australia among women who have unprotected intercourse during lactation amenorrhea and use contraception when menses resume, 1.7% become pregnant in the first 6 months of breast-feeding, 7% after 12 months, and 13% after 24 months.<sup>474</sup> In a study of 422 middle-class women in Santiago, Chile, there was only one pregnancy (in month 6) when lactational amenorrhea was consciously relied upon for contraception.<sup>475</sup> This was equal to a cumulative 6-month life-table pregnancy rate of 0.45%. However, this accomplishment required an extensive program of education and support. In this study, 9% of exclusively breast-feeding women had resumption of menses by the end of 3 months and 19% by the end of 6 months. This increased suppression of fertility undoubtedly reflected the intensity of the breast-feeding program and the motivation of the participants. In Chile, the probability of pregnancy in breast-feeding women who are amenorrheic was reported as 0.9% at 6 months and 17% at 112 months, and in menstruating women, 36% at 6 months and 55% at 12 months.<sup>476</sup> In Pakistan, women who deliberately chose lactational amenorrhea as a method of contraception experienced a pregnancy rate of only 1.1% at 12 months if they remained amenorrheic.<sup>477</sup>

An international group of researchers in the area of lactational infertility reached the following consensus in 1989, called the Bellagio Consensus (after the site of the

conference at Bellagio, Italy)<sup>478</sup>:

**The maximum birth spacing effect of breast-feeding is achieved when a mother “fully” or nearly fully breast-feeds and remains amenorrheic. When these two conditions are fulfilled, breast-feeding provides more than 98% protection from pregnancy in the first 6 months.**

Full breast-feeding means that the infant’s total suckling stimulus is directed to the mother. There is no diminution of suckling by supplementation or the use of a pacifier. The Bellagio degree of protection in the first 6 months of full or nearly full breast-feeding has been confirmed in clinical studies.<sup>459,479</sup>

The World Health Organization conducted a large prospective study examining the relationship between infant feeding and amenorrhea, as well as the rate of pregnancy during lactational amenorrhea.<sup>480,481,482,483</sup> Women who were still breast-feeding and remained amenorrheic had pregnancy rates of 0.8% at 6 months and 4.4% at 12 months, again confirming the Bellagio Consensus.

The duration of postpartum lochia is variable and can make it difficult to detect the onset of menstrual bleeding. In the World Health Organization study, postpartum lochia was present from a minimum of 2 days to a maximum of 90 days, with an average duration of 27 days.<sup>483</sup> Most women with lactational amenorrhea will not experience true menstrual bleeding before postpartum day 56 (8 weeks). Breast-feeding frequency has no effect on the duration of postpartum lochia.

**Therefore, only amenorrheic women who exclusively breast-feed at regular intervals, including nighttime, during the first 6 months have the contraceptive protection equivalent to that provided by oral contraception; with menstruation or after 6 months postpartum, the risk of ovulation increases.<sup>453,460,484</sup> Supplemental feeding increases the risk of ovulation (and pregnancy) even in amenorrheic women.<sup>476</sup> Total protection against pregnancy is achieved by the exclusively breast-feeding woman for a duration of only 10 weeks.<sup>460</sup>**

Women skilled in the cervical mucus method can detect evidence of fertile-type mucus prior to the first menses in the postpartum period. However, there are many false-positive and false-negative interpretations.<sup>485</sup> This method cannot be used with a great deal of confidence until regular menses are resumed.



# POSTPARTUM CONTRACEPTION

---

A recent pregnancy and a new infant provide strong motivation for the mother to consider contraception. In non–breast-feeding women, ovulation can occur during the 4th postpartum week. We urge clinicians and patients to start a new tradition: schedule the first postpartum visit during the **3rd week after delivery**. Even breast-feeding women should be evaluated at this time, to consider whether breast-feeding is full and exclusive or whether an additional contraceptive method is necessary.

Additional contraception is necessary during lactation for most women. That is not to say that full breast-feeding should not be encouraged and that the protection obtained in the first 6 months of breast-feeding shouldn't be emphasized. But after 3 months, the first ovulation can precede the first menstrual bleed. Half of women studied who are not fully breast-feeding ovulate before the 6th week, the time of the traditional postpartum visit; a visit during the 3rd postpartum week for both breast-feeding and non–breast-feeding mothers is strongly recommended for contraceptive counseling.

**In the presence of FULL breast-feeding, a contraceptive method should be used beginning in the 3rd postpartum month.**

**With PARTIAL breast-feeding or NO breast-feeding, a contraceptive method should begin during the 3rd postpartum week.**

**After the spontaneous or elective termination of a pregnancy of less than 12 weeks, steroid contraception can be started immediately. After a pregnancy of 12 or more weeks, the 3rd-postpartum-week rule should be followed if the pregnancy is term or near term to avoid the postpartum risk of venous thromboembolism (discussed later).**

The suppression of prolactin secretion with a dopamine agonist (e.g., bromocriptine), not surprisingly, is associated with the return of gonadotropin secretion in the 2nd postpartum week and an earlier return to ovulation and menses.<sup>486</sup> In women who receive dopamine agonist treatment at or immediately after delivery, contraception is required a week earlier, in the 2nd week postpartum.<sup>487</sup>

Oral contraception even in low-dose formulations has been demonstrated to diminish the quantity and quality of lactation in postpartum women. Although there has been concern regarding the potential hazard of transfer of contraceptive steroids to the infant (a significant amount of the progestational component is secreted into breast milk),<sup>488,489</sup> no adverse effects have thus far been identified. Because iron is an important factor in the bacteriostatic activity of breast milk, it is good to know that iron and copper concentrations in breast milk are not affected by the use of oral contraceptives.<sup>490</sup>

Women who use oral contraception have a lower incidence of breast-feeding after the 6th postpartum month, regardless of whether oral contraception is started at the first, second, or third postpartum month.<sup>491,492,493</sup> In adequately nourished women, no impairment of infant growth and development can be detected; presumably, compensation is achieved through either supplementary feedings or increased suckling.<sup>494,495,496</sup> In an 8-year follow-up study of children breast-fed by mothers using oral contraceptives, no effect could be detected on diseases, intelligence, or psychological behavior.<sup>497</sup> This study also found that mothers on oral contraceptives lactated a significantly shorter period of time than controls, a mean of 3.7 months versus 4.6 months in controls.

Because of the concern regarding the impact of oral contraceptives on breast-feeding, a useful alternative is to combine the contraceptive effect of lactation with the progestin-only minipill; there is no evidence for any adverse effect on breast-feeding as measured by milk volume and infant growth and development.<sup>494,495,496</sup>

In contrast to the combined oral contraceptive, the progestin-only minipill even provides a modest boost to milk production, and women using the minipill breast-feed longer and add supplementary feeding at a later time.<sup>494,498,499</sup> The combination of lactation and the progestin-only minipill is associated with near-total contraceptive efficacy. In addition, the minipill can protect against the bone loss associated with lactation, a potential advantage in undernourished women.<sup>500</sup> Because of the slight positive impact on lactation, the minipill can be started immediately after delivery.<sup>501</sup> Progestins alone do not increase the risk of venous thrombosis.<sup>502,503</sup>

# The Risk of Postpartum Venous Thromboembolism

Although venous thromboembolism is a rare event, the potential for a catastrophic consequence makes this an important consideration. In the past, the risk of venous thromboembolism was believed to be concentrated in the postpartum period. It is now apparent that the postpartum incidence of this problem has decreased and antepartum diagnosis is now more common. Undoubtedly a contributing factor to this change is the now common practice of early ambulation after delivery. Over a 30-year period in Minnesota, the incidence of antepartum venous thromboembolism remained constant, but postpartum cases decreased more than twofold; nevertheless, the number of cases was still 5 times higher among postpartum women compared with pregnant women.<sup>504</sup> In a large American surveillance study, half of the events occurred during pregnancy and half postpartum.<sup>505</sup> In Spain, however, cases were slightly more frequent during pregnancy compared with the postpartum period.<sup>506</sup> In a large multicenter American registry, there were almost twice as many antepartum cases than postpartum cases.<sup>507</sup>

In Sweden over a 10-year period, the venous thromboembolism mortality rate was similar comparing pregnancy with oral contraceptive users; the incidence rate was about 9 cases per 1,000,000 women-years.<sup>508,509</sup> Most cases of venous thromboembolism occur in individuals with well-recognized risk factors, including older age, obesity, severe varicose veins, cancer, fractures, surgery, and inflammatory bowel disease.<sup>510</sup> Pregnancy and combined estrogen-progestin contraception must be added to this list.

The increase of venous thromboembolism begins shortly after conception, is maintained throughout pregnancy and the first week postpartum, and then gradually declines, reaching baseline levels about 4–6 weeks postpartum.<sup>504</sup> Venous thromboembolism more than 6 weeks postpartum is very uncommon. To minimize the risk of postpartum venous thromboembolism, good contraceptive practice has for decades emphasized the avoidance of exposure to pharmacologic levels of estrogen immediately after delivery. **Therefore, we recommend that non-breast-feeding mothers use a progestin-only contraceptive method beginning in the 3rd postpartum week; a change to a combination estrogen-progestin method can be initiated in the 7th postpartum week. This recommendation also applies to the vaginal and transdermal methods of estrogen-progestin contraception.**

# **OTHER CONSIDERATIONS**

---

# Prolactin-Secreting Adenomas

Because estrogen is known to stimulate prolactin secretion and to cause hypertrophy of the pituitary lactotrophs, it is appropriate to be concerned over a possible relationship between oral contraception and prolactin-secreting adenomas. Case-control studies have uniformly concluded that no such relationship exists.<sup>511,512</sup> Data from both the Royal College of General Practitioners and the Oxford Family Planning Association studies indicated no increase in the incidence of pituitary adenomas.<sup>513</sup> Previous use of oral contraceptives is not related to the size of prolactinomas at presentation and diagnosis.<sup>513,514</sup> Oral contraception can be prescribed to patients with pituitary microadenomas without fear of subsequent tumor growth.<sup>515,516</sup> **We have routinely prescribed oral contraception to patients with pituitary microadenomas and have never observed evidence of tumor growth.**

## Postpill Amenorrhea

The approximate incidence of “postpill amenorrhea” is 0.7–0.8%, which is equal to the incidence of spontaneous secondary amenorrhea,<sup>451,517,518</sup> and there is no evidence to support the idea that oral contraception causes secondary amenorrhea. If a cause-and-effect relationship exists between oral contraception and subsequent amenorrhea, one would expect the incidence of infertility to be increased after a given population discontinues the use of oral contraception. In those women who discontinue oral contraception in order to get pregnant, 50% conceive by 3 months, and after 2 years, a maximum of 15% of nulliparous women and 7% of parous women fail to conceive,<sup>451</sup> rates comparable with those quoted for the prevalence of spontaneous infertility. Attempts to document a cause-and-effect relationship between oral contraceptive use and secondary amenorrhea have failed.<sup>519</sup> Although patients with this problem come more quickly to our attention because of previous oral contraceptive use and follow-up, there is no cause-and-effect relationship. Women who have not resumed menstrual function within 12 months should be evaluated as any other patient with secondary amenorrhea.

## Use During Puberty

Should oral contraception be advised for a young woman with irregular menses and oligo-ovulation or anovulation? The fear of subsequent infertility should not be a deterrent to providing appropriate contraception. Women who have irregular menstrual periods are more likely to develop secondary amenorrhea whether they use oral contraception or not. The possibility of subsequent secondary amenorrhea is less of a risk and a less urgent problem for a young woman than leaving her unprotected. The need for contraception takes precedence.

There is no evidence that the use of oral contraceptives in the pubertal, sexually active girl impairs growth and development of the reproductive system.<sup>443</sup> Again, the most important concern is and should be the prevention of an unwanted pregnancy. For most teenagers, oral contraception, dispensed in a 28-day package for better compliance, is the contraceptive method of choice. However, even better continuation can be achieved with the vaginal and transdermal methods of estrogen-progestin contraception.

# Eye and Ear Diseases

In the 1960s and 1970s, there were numerous anecdotal reports of eye disorders in women using oral contraception. An analysis of the two large British cohort studies (the Royal College of General Practitioners' study and the Oxford Family Planning Association Study) could find no increase in risk for the following conditions: conjunctivitis, keratitis, iritis, lacrimal disease, strabismus, cataract, glaucoma, and retinal detachment.<sup>520</sup> Retinal vascular lesions were slightly more common in recent users of oral contraception, but this finding did not reach statistical significance. Contact lens may be less well tolerated, requiring more frequent use of wetting solutions.

The Oxford Family Planning Association Study could detect no evidence of any adverse effects of oral contraception on ear disorders.<sup>521</sup>



# Multiple Sclerosis

There is no evidence in third cohort studies (the Royal College of General Practitioners' study, the Oxford Family Planning Association Study, and the Nurses' Health Study) that there is any effect of oral contraceptive use on the risk or course of multiple sclerosis.<sup>522,523,524</sup> A case-control study suggested that recent users of oral contraceptives had a substantial reduction in the incidence of multiple sclerosis, perhaps delaying the onset of the disease.<sup>525</sup> A small (seven women on oral contraceptives) prospective study indicated that symptoms increased during the pill-free interval.<sup>526</sup> Patients with multiple sclerosis should consider using the regimen of daily, continuous administration.

# **INFECTIONS AND ORAL CONTRACEPTION**

---

# Viral Sexually Transmitted Infections

The viral sexually transmitted infections (STIs) include human immunodeficiency virus (HIV), human papillomavirus (HPV), herpes simplex virus (HSV), and hepatitis B virus (HBV). At the present time, no known associations exist between oral contraception and the viral STIs. Of course, significant prevention includes barrier methods of contraception.

Thus far, most studies have found no association between oral contraceptive use and HIV seropositivity, and some have indicated a protective effect.<sup>527,528,529</sup> Steroid contraception used by HIV-positive women does not affect the progress of the disease.<sup>530,531</sup>

Antiretroviral drugs may decrease oral contraceptive efficacy by affecting drug metabolism or causing diarrhea and vomiting. Treatment usually consists of a combination of three or four drugs, and the available studies often reflect drugs and doses not currently used. Therefore, the degree of clinical impact on hormonal contraception, if any, is not well studied.<sup>532</sup> Nevertheless, the studies suggest that some of the antiretroviral drugs are associated with a decrease in steroid levels during oral contraceptive use.

**A dual approach is recommended, combining the contraceptive efficacy and protection against PID offered by steroid contraception with the use of a barrier method for prevention of viral STIs and added contraception.**

# Bacterial STIs

STIs are one of the most common public health problems in the United States. Pelvic inflammatory disease (PID) is usually a consequence of STIs. The best estimate of subsequent tubal infertility is derived from an excellent Swedish report: approximately 12% after one episode of PID, 23% after two episodes, and 54% after three episodes.<sup>533</sup> Because pelvic infection is the single greatest threat to the reproductive future of a young woman, the now recognized protection offered by oral contraception against PID is highly important.<sup>534,535,536</sup> **The risk of hospitalization for PID is reduced by approximately 50–60%, but at least 12 months of use is necessary, and the protection is limited to current users.**<sup>534,537</sup> Furthermore, if a patient does get a pelvic infection, the severity of the salpingitis found at laparoscopy is decreased.<sup>538,539</sup> The mechanism of this protection remains unknown. Speculation includes thickening of the cervical mucus to prevent movement of pathogens and bacteria-laden sperm into the uterus and tubes and decreased menstrual bleeding, reducing movement of pathogens into the tubes, as well as a reduction in “culture medium.” This protection probably accounts for the greater fertility rate observed in previous users of oral contraception.<sup>443,444</sup>

The argument has been made that this protection is limited to gonococcal disease, and chlamydial infections may even be enhanced. Most published studies have reported a positive association of oral contraceptives with lower genital tract chlamydial cervicitis.<sup>540,541</sup> Because lower genital tract infections caused by chlamydia are on the rise (now the most prevalent bacterial STI in the United States) and the rate of hospitalization for PID is also increased, it is worthwhile for both patients and clinicians to be alert for symptoms of cervicitis or salpingitis in women on oral contraception who are at high risk of STIs (multiple sexual partners, a history of STI, or cervical discharge). The mechanism for the association between chlamydial cervicitis and oral contraceptives may be the well-recognized extension of the columnar epithelium from the endocervix out over the cervix (ectopia) that occurs with oral contraceptive use.<sup>542</sup> This ectropion may allow a more effective collection of cervical specimens for culture, thus introducing detection bias into the epidemiologic studies.

Despite this potential relationship between oral contraception and chlamydial infections, it should be emphasized that there is no evidence for an impact of oral contraceptives increasing the incidence of tubal infertility.<sup>543</sup> In fact, case-control studies indicated that oral contraceptive users with chlamydia infection are protected against symptomatic PID.<sup>544,545</sup> A case-control study suggested that oral contraceptive users are more likely to harbor unrecognized endometritis and that this would explain the discrepancy between the observed rates between lower and upper tract infection.<sup>546</sup>

However, this would not explain the lack of an association between oral contraceptive use and tubal infertility. Thus, the influence of oral contraception on the upper reproductive tract may be different than on the lower tract. These observations on fertility are derived mostly, if not totally, from women using oral contraceptives containing 50 µg of estrogen. The continued progestin dominance of the lower-dose formulations, however, should produce the same protective impact. Early evidence indicated protection with low-dose oral contraceptives, but a later study failed to find a reduction in upper genital tract disease associated with oral contraceptives or barrier methods.<sup>537,547</sup>

## Other Infections

In the British prospective studies of high-dose oral contraceptives, urinary tract infections were increased in users of oral contraception by 20%, and a correlation was noted with estrogen dose. An increased incidence of cervicitis was also reported, an effect related to the progestin dose. The incidence of cervicitis increased with the length of time the pill was used, from no higher after 6 months to 3 times higher by the 6th year of use. A significant increase in a variety of viral diseases, for example, chickenpox, was observed, suggesting steroid effects on the immune system. The prevalence of these effects with low-dose oral contraception is unknown.

Oral contraception appears to protect against bacterial vaginosis and infections with *Trichomonas*.<sup>548,549,550,551</sup> Evidence is lacking to convincingly implicate oral contraception with vaginal infections with *Candida* species<sup>548</sup>; however, clinical experience is sometimes impressive when recurrence and cure repeatedly follow use and discontinuation of oral contraception.

Vaginal flora are not affected by the presence of vaginal ring contraception.<sup>552,553</sup> Despite no change in inflammatory vaginal flora, one well-done study reported that ring users have slightly more vaginal wetness (not sufficient to cause discontinuation), perhaps due to an increase in lactobacilli.<sup>554</sup>

# **PATIENT MANAGEMENT**

---

# Absolute Contraindications to the Use of Oral Contraception

1. Thrombophlebitis, thromboembolic disorders (including a close family history, parent or sibling, suggestive of an inherited susceptibility for venous thrombosis), cerebral vascular disease, coronary occlusion, or a past history of these conditions, or conditions predisposing to these problems.
2. Markedly impaired liver function or liver cancer. Steroid hormones are contraindicated in patients with hepatitis until liver function tests return to normal.
3. History of coronary heart disease or cerebrovascular disease.
4. Migraine headaches with aura.
5. Diabetes mellitus with vascular disease.
6. Known or suspected breast cancer.
7. Undiagnosed abnormal vaginal bleeding.
8. Known or suspected pregnancy.
9. Smokers over the age of 35.
10. Severe hypercholesterolemia or hypertriglyceridemia.
11. Uncontrolled hypertension.
12. Breast-feeding and less than 21 days postpartum.
13. Surgery with prolonged nonmobility.
14. History of peripartum cardiomyopathy.



# **Relative Contraindications Requiring Clinical Judgment and Informed Consent**

1. Migraine headaches without aura
2. Controlled hypertension
3. Gestational diabetes
4. Diabetes mellitus
5. Seizure disorders
6. Obstructive jaundice in pregnancy
7. Sickle cell disease or sickle C disease
8. Gallbladder disease
9. Mitral valve prolapse
10. Systemic lupus erythematosus
11. Hyperlipidemia
12. Smoking younger than 35
13. Hepatic disease

# CLINICAL DECISIONS

---

# Surveillance

Many women can be prescribed hormonal contraception without a clinical breast and pelvic examination.<sup>555</sup> Problems requiring further evaluation can be identified with a careful medical history and measurement of blood pressure. Subsequently, in view of the increased safety of low-dose preparations for healthy young women with no risk factors, patients need be seen only every 12 months for exclusion of problems by history, measurement of the blood pressure, urinalysis, breast examination, palpation of the liver, and pelvic examination with Pap smear if indicated. Women with risk factors should be seen every 6 months by appropriately trained personnel for screening of problems by history and blood pressure measurement. Breast and pelvic examinations are necessary only yearly. It is worth emphasizing that better continuation is achieved by reassessing new users within 1–2 months. It is at this time that subtle fears and unvoiced concerns need to be confronted and resolved.

Oral contraception is safer than most people think it is, and the low-dose preparations are extremely safe. Health care providers should make a significant effort to get this message to our patients (and our colleagues). We must make sure our patients receive adequate counseling, either from ourselves or from our professional staff. The major reason why patients discontinue oral contraception is fear of side effects.<sup>556</sup> Let's take time to put the risks into proper perspective and to emphasize the benefits as well as the risks.

Laboratory surveillance should be used only when indicated. Routine biochemical measurements fail to yield sufficient information to warrant the expense. Assessing the cholesterol-lipoprotein profile and carbohydrate metabolism should follow the same guidelines applied to all patients, users and nonusers of contraception. The following is a useful guide as to who should be monitored with blood screening tests for glucose, lipids, and lipoproteins:

Women 35 years or older—then every 3 years if screening tests are normal

Women with a strong family history of heart disease, diabetes mellitus, or hypertension

Women with gestational diabetes mellitus

Women with xanthomatosis

Obese women

Diabetic women

# Choice of Pill

The therapeutic principle remains: utilize the formulations that give effective contraception and the greatest margin of safety. Use only low-dose preparations containing less than 50  $\mu\text{g}$  of estrogen, combined with low doses of new or old progestins. Current data support the view that there is greater safety with preparations containing less than 50  $\mu\text{g}$  of estrogen. The arguments in this chapter indicate that all patients should begin oral contraception with low-dose products and that patients on higher-dose oral contraception should be changed to the low-dose preparations. Stepping down to a lower dose can be accomplished immediately with no adverse reactions such as increased bleeding or failure of contraception.

**An extended regimen or continuous dosing deserves consideration. Breakthrough and withdrawal bleeding is reduced with these schedules, and because of greater suppression of FSH and follicular growth, it is very likely that the failure rates with typical use will be less.**

The multiphasic preparations do have a reduced progestin dosage compared with some of the existing monophasic products; however, based on currently available information, there is little difference between the low-dose monophasics and the multiphasics.

The pharmacologic effects in animals of various formulations have been used as a basis for therapeutic recommendations in selecting the optimal oral contraceptive pill. **These recommendations (personalized medicine approach) have not been supported by appropriately controlled clinical trials. All too often this leads to the prescribing of a pill of excessive dosage with its attendant increased risk of serious side effects.** It is worth repeating our earlier comments on potency. Oral contraceptive potency (specifically progestin potency) is no longer a consideration when it comes to prescribing birth control pills. The potency of the various progestins has been accounted for by appropriate adjustments of dose. The biologic effect of the various progestational components in current low-dose oral contraceptives is approximately the same. Our progress in lowering the doses of the steroids contained in oral contraceptives has yielded products with little serious differences.

# Pill Taking

Effective contraception is present during the first cycle of pill, transdermal, or vaginal ring use, provided the hormones are started no later than the 5th day of the cycle and no pills are missed. Thus, starting oral contraception on the first day of menses ensures immediate protection. The Sunday start packages, beginning on the first Sunday following the onset of menstruation, can be easier to remember, and it usually avoids menstrual bleeding on weekends. It is probable, **but not totally certain**, that even if a dominant follicle should emerge in occasional patients after a Sunday start, an LH surge and ovulation would still be prevented.<sup>557</sup> **We prefer the first-day start and no longer recommend the Sunday start. If the Sunday start is used, it is prudent to advise patients to use added protection in the first week of use.**

The conventional approach to starting oral contraceptives, either with menses or on Sunday, carries with it a delay in achieving contraception for many women. Many clinicians advocate the Quick-Start method, an **immediate or same-day start**, on the day the patient receives her prescription, regardless of the patient's day in her cycle.<sup>558</sup> Combined with a backup method for the first week, preferably condoms, an immediate start may avoid unwanted pregnancies occurring during the delay before initiating oral contraception with the conventional methods. In some instances of appropriate coital history, a sensitive pregnancy test would be a wise precaution before starting treatment. Women who use the immediate start method have better continuation rates and do not experience an increase in breakthrough bleeding.<sup>63,559</sup>

## Starting Choices for Steroid Contraception

### 1. Start on first day of menses

**Advantage:** assured immediate protection

### 2. Start on first Sunday after onset of menses

**Advantage:** avoids weekend menses

**Disadvantage:** backup protection advisable during first week

### 3. Quick-Start (immediate, same-day start)

**Advantage:** better compliance.

**Disadvantage:** backup protection necessary during first week; rule out pregnancy before beginning.

**There is no scientific rationale for recommending a pill-free interval. The serious side effects are not eliminated by pill-free intervals. This practice all too often results in unwanted pregnancies.**

How important is it to take the oral contraceptive at the same time every day? Although not well studied, there is reason to believe precise pill taking minimizes breakthrough bleeding. In addition, compliance is improved by a fixed schedule that is habit-forming.

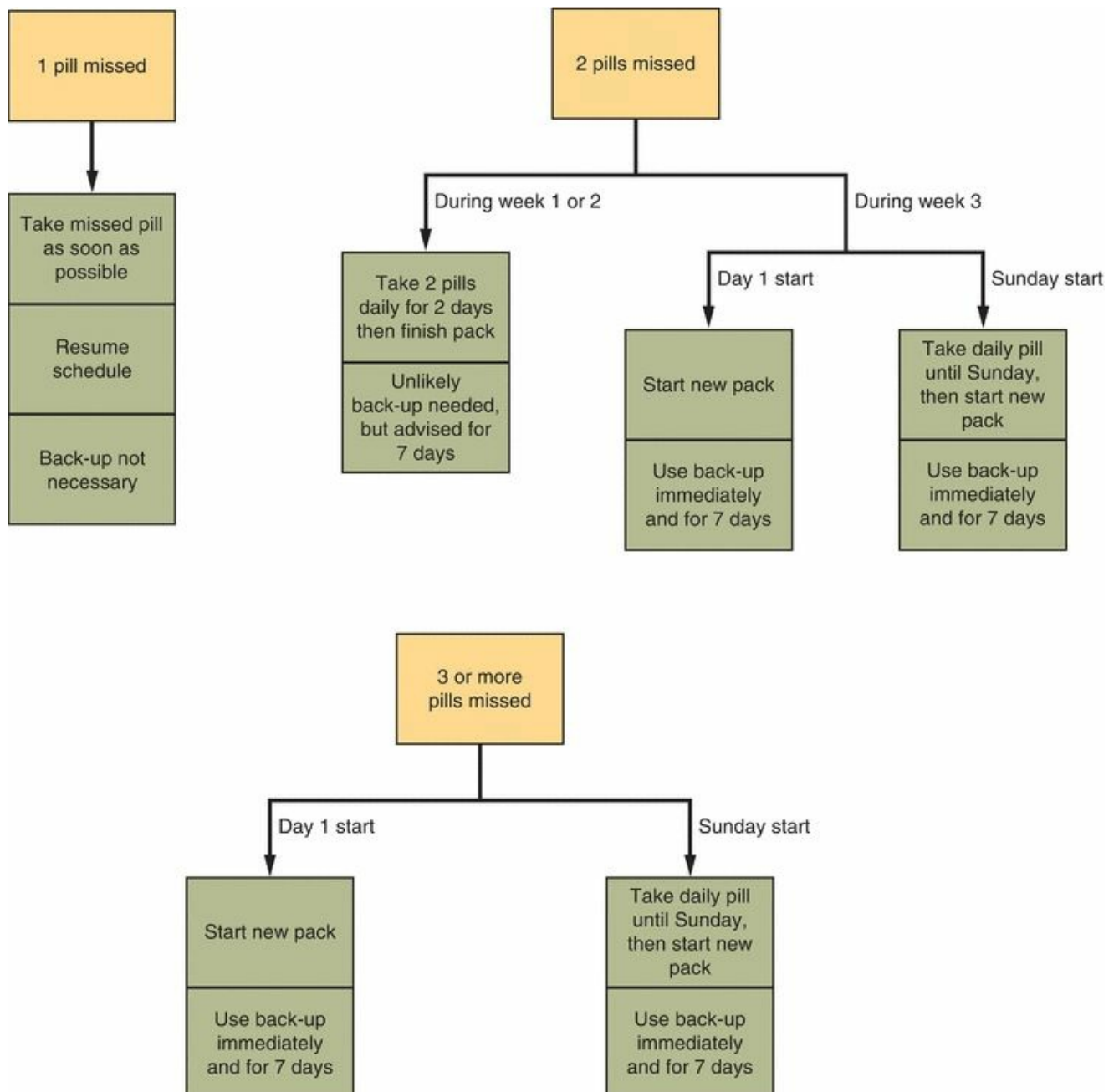
# Avoiding Menstrual Bleeding

Clinicians for years have prescribed unlimited daily oral contraceptives to treat conditions such as endometriosis, bleeding disorders, menstrual seizures, and menstrual migraine headaches, even to avoid bleeding in athletes and busy individuals. Withdrawal bleeding is not a desired experience for many women, and today, monthly bleeding, periodic bleeding, and no bleeding are choices available for women. Any combination oral contraceptive can be used on a daily continuous dosing basis; even the lowest-estrogen dose formulations provide excellent bleeding and side effect profiles in a continuous regimen.<sup>77,86</sup> A further benefit of continuous dosing is simplification of the pill-taking schedule with the potential of better compliance and a lower failure rate.

Occasionally patients would like to postpone a menstrual period, for example, for a wedding, holiday, or vacation. This can be easily achieved by omitting the hormone-free interval. Simply start a new package of pills the next day after finishing the series of **active** pills in the previous package.

# What to Do When Pills Are Missed

Irregular pill taking is a common occurrence. Using an electronic monitoring device to measure compliance, it was apparent that consistency of pill taking is even worse than what patients report; only 33% of women were documented to have missed no pills in cycle 1, and by cycle 3, about one-third of the women missed 3 or more pills with many episodes of consecutive days of missed pills.<sup>560</sup> These data indicate that women become less careful over time, emphasizing the importance of repeatedly reviewing with patients what to do when pills are missed (Figure 22.14).





## FIGURE 22.14

**If a woman misses 1 pill**, she should take that pill as soon as she remembers and take the next pill as usual. No backup method is needed.

**If she misses 2 pills in the first 2 weeks**, she should take two pills on each of the next 2 days; it is unlikely that a backup method is needed, but the official consensus is to recommend backup for the next 7 days, especially if the missed pills occurred in the first week. **If the patient is using an oral contraceptive with 20 µg or less of estrogen and the missed pills occur in the first week, consider the use of emergency contraception.**

**If 2 pills are missed in the 3rd week or if more than 2 active pills are missed at any time**, another form of contraception should be used as backup immediately and for 7 days; if a Sunday starter, keep taking a pill every day until Sunday, and on Sunday, start a new package; if a non-Sunday starter, start a new package the same day.

Studies have questioned whether missing pills has an impact on contraception. One study demonstrated that skipping 4 consecutive pills at varying times in the cycle did not result in ovulation.<sup>560</sup> Studies in which women deliberately lengthen their pill-free interval up to 11 days have failed to show signs of ovulation.<sup>78,561</sup> So far there is no evidence that moving to lower doses has had an impact on the margin of error. Despite greater follicular activity with the lowest-dose oral contraceptives, ovulation is still effectively prevented.<sup>52</sup> However, the studies have involved small numbers of women, and given the large individual variation, it is possible that some women might be at risk with a small increase in the pill-free interval. Although the progestational effects on endometrium and cervical mucus serve to ensure good contraceptive efficacy,<sup>94</sup> conservative advice regarding missing pills is the safest message to convey.

The most prevalent problems that can be identified associated with apparent oral contraceptive failures are vomiting and diarrhea.<sup>93</sup> **Even if no pills have been missed, patients should be instructed to use a backup method for at least 7 days after an episode of gastroenteritis.**

# CLINICAL PROBLEMS

---

# Breakthrough Bleeding

A major continuation problem is breakthrough bleeding. Breakthrough bleeding gives rise to fears and concerns; it is aggravating and even embarrassing. Therefore, on starting oral contraception, patients need to be fully informed about breakthrough bleeding.

There are two characteristic breakthrough bleeding problems: irregular bleeding in the first few months after starting oral contraception and unexpected bleeding after many months of use. Effort should be made to manage the bleeding problem in a way that allows the patient to remain on low-dose oral contraception. **There is no evidence that the onset of bleeding is associated with decreased efficacy, no matter what oral contraceptive formulation is used, even the lowest-dose products.** Indeed, in a careful study, breakthrough bleeding did not correlate with changes in the blood levels of the contraceptive steroids.<sup>59</sup>

The most frequently encountered breakthrough bleeding occurs in the first few months of use. The incidence is greatest in the first 3 months, ranging from 10% to 30% in the first month to less than 10% in the third. Breakthrough bleeding rates are higher with the lowest-dose oral contraceptives, but not dramatically.<sup>54,55</sup> Breakthrough bleeding is higher in women who smoke and in smokers who use formulations with 20 µg ethinyl estradiol.<sup>57</sup> However, the differences among the various formulations currently available are of minimal clinical significance. The basic pattern is the same, highest in the first month and a greater prevalence in smokers, especially in later cycles.

Breakthrough bleeding is best managed by good educational anticipatory preparation of the patient at initiation of treatment, with encouragement and reassurance when bleeding occurs. This bleeding usually disappears by the third cycle in the majority of women. Women should be strongly advised to call the clinician before discontinuing contraception. If necessary, even this early pattern of breakthrough bleeding can be treated as outlined below. It is helpful to explain to the patient that this bleeding represents tissue breakdown as the endometrium adjusts from its usual thick state to the relatively thin state allowed by the hormones in oral contraceptives.

Breakthrough bleeding that occurs after many months of oral contraceptive use is a consequence of the progestin-induced decidualization. This endometrium and the blood vessels within the endometrium tend to be fragile and prone to breakdown and asynchronous bleeding.

There are two recognized factors (both preventable) that are associated with a greater incidence of breakthrough bleeding. Consistency of use and smoking increase spotting and bleeding, but inconsistency of pill taking is more important and has a greater effect in later cycles, whereas smoking exerts a general effect at any time.<sup>562</sup>

Reinforcement of consistent pill taking can help minimize breakthrough bleeding. Young women who smoke are more likely to discontinue oral contraception,<sup>563</sup> and this may be partly due to irregular bleeding.

Cervical infection can be another cause of breakthrough bleeding; the prevalence of cervical chlamydial infections is higher among oral contraceptive users who report breakthrough bleeding.<sup>564</sup>

If bleeding occurs just before the end of the pill cycle, it can be managed by having the patient stop the pills, wait 7 days, and start a new cycle. If breakthrough bleeding is prolonged or if it is aggravating for the patient, regardless of the point in the pill cycle, control of the bleeding can be achieved with a short course of exogenous estrogen. Conjugated estrogen, 1.25 mg, or estradiol, 2 mg, is administered daily for 7 days when the bleeding is present, no matter where the patient is in her pill cycle. The patient continues to adhere to the schedule of pill taking. Usually, one course of estrogen solves the problem, and recurrence of bleeding is unusual (but if it does recur, another 7-day course of estrogen is effective).

Remember that there is a significant reduction in the number of bleeding and spotting days, as well as the amount of withdrawal bleeding, in women using a 24-day regimen. Studies comparing 24- and 21-day regimens have indicated that some of the breakthrough bleeding experienced by women on 21-day regimens is due to follicular growth, a rise in endogenous estrogen levels, followed by demise of the follicle and estrogen withdrawal bleeding. There are two operative mechanisms, therefore, in breakthrough bleeding: progestin-induced atrophic endometrium with vascular fragility and withdrawal bleeding in response to the rise and fall of endogenous estrogen levels associated with follicular growth and demise. Greater suppression of follicular growth with 24-day regimens results in less bleeding.

**Breakthrough bleeding in women using steroid contraception without a break, daily continuous dosing of oral contraceptives, is best treated by discontinuing medication for 3 or 4 days (no more than once every 3 weeks), allowing a withdrawal menstrual sloughing.**<sup>102,565</sup>

Responding to irregular bleeding by having the patient take 2 or 3 pills is not effective. The progestin component of the pill will always dominate; hence, doubling the number of pills will also double the progestational impact and its decidualizing, atrophic effect on the endometrium and its destabilizing effect on endometrial blood vessels. The addition of extra estrogen while keeping the progestin dose unchanged is logical and effective. This allows the patient to remain on the low-dose formulation with its advantage of greater safety. Breakthrough bleeding, in our view, is not sufficient reason to expose patients to the increased risks associated with higher-dose oral contraceptives. Any bleeding that is not handled by this routine requires investigation

for the presence of pathology.

There is no evidence that any oral contraceptive formulations that are approximately equivalent in estrogen and progestin dosage are significantly different in the rates of breakthrough bleeding. Clinicians often become impressed that switching to another product effectively stops the breakthrough bleeding. It is more likely that the passage of time is the responsible factor, and bleeding would have stopped regardless of switching and regardless of product.

# Amenorrhea

With low-dose pills, the estrogen content is not sufficient in some women to stimulate endometrial growth. The progestational effect dominates to such a degree that a shallow atrophic endometrium is produced, lacking sufficient tissue to yield withdrawal bleeding. It should be emphasized that permanent atrophy of the endometrium does not occur and resumption of normal ovarian function will restore endometrial growth and development. Indeed, there is no harmful, permanent consequence of amenorrhea while on oral contraception.

The major problem with amenorrhea while on oral contraception is the anxiety produced in both patient and clinician because the lack of bleeding may be a sign of pregnancy. The patient is anxious because of the uncertainty regarding pregnancy, and the clinician is anxious because of the medicolegal concerns stemming from the old studies, which indicated an increased risk of congenital abnormalities among the offspring of women who inadvertently used oral contraception in early pregnancy. There is no association between oral contraception and an increased risk of congenital malformation, and there is no increased risk of having abnormal children.

The incidence of amenorrhea in the first year of use with low-dose oral contraception is less than 2%. This incidence increases with duration, reaching perhaps 5% after several years of use. It is important to alert patients upon starting oral contraception that diminished bleeding and possibly no bleeding may ensue.

Amenorrhea is a difficult management problem. A pregnancy test will allow reliable assessment for the presence of pregnancy even at this early stage.

Many women are reassured with an understanding of why there is no bleeding and are able to continue on the pill despite the amenorrhea. Some women cannot reconcile themselves to a lack of bleeding, and this is an indication for trying other formulations (a practice unsupported by any clinical trials, and, therefore, the expectations are uncertain). But again, this problem does not warrant exposing patients to the greater risks of major side effects associated with higher-dose products.

Some clinicians have observed that the addition of extra estrogen for 1 month (1.25 mg conjugated estrogens or 2 mg estradiol daily throughout the 21 days while taking the oral contraceptive) will rejuvenate the endometrium and withdrawal bleeding will resume, persisting for many months.

# Weight Gain

The complaint of weight gain is frequently cited as a major problem with compliance. Yet, studies of the low-dose preparations fail to demonstrate a significant weight gain with oral contraception and no major differences among the various products.<sup>306,307,308,309,310,311,313</sup> There is also no association between transdermal contraception and weight gain.<sup>249</sup> This is obviously a problem of perception, a conclusion supported by finding the weight gain identical in treated and placebo groups. The clinician has to carefully reinforce the lack of association between low-dose oral contraceptives and weight gain and focus the patient on the real culprit: diet and level of exercise. Most women gain a moderate amount of weight as they age, whether they take oral contraceptives or not.

# Acne

Low-dose oral contraceptives improve acne regardless of which product is used.<sup>303,304,312,566,567,568,569,570,571</sup> The low progestin doses (including levonorgestrel formulations) currently used are insufficient to stimulate an androgenic response, and they provide effective treatment for acne and hirsutism. In addition to the inhibitory action of the progestational component on LH and the subsequent reduction in ovarian androgen production, estrogen-progestin contraceptives provide a further benefit because of the increase in SHBG levels induced by the estrogen component. The increase in SHBG results in a greater androgen-binding capacity with a decrease in free testosterone levels. The progestins in estrogen-progestin contraceptives also inhibit 5-reductase activity in the skin, further contributing to the clinical impact of oral contraceptives on hirsutism.<sup>572</sup>



# Ovarian Cysts

Anecdotal reports suggested that functional ovarian cysts are encountered more frequently and suppress less easily with multiphasic formulations. This observation failed to withstand careful scrutiny.<sup>573,574</sup> Functional ovarian cysts occurred less frequently in women on higher-dose oral contraception.<sup>575</sup> This protection is reduced with the current lower-dose products to the point where little effect can be measured.<sup>574,576,577,578,579</sup> Thus, the risk of such cysts is not eliminated, and, therefore, clinicians can encounter such cysts in patients taking any of the oral contraceptive formulations.

# Drugs that Affect Efficacy

There are many anecdotal reports of patients who conceived on oral contraceptives while taking antibiotics. There is little evidence, however, that antibiotics such as ampicillin, metronidazole, quinolone, and tetracycline, which reduce the bacterial flora of the gastrointestinal tract, affect hormonal contraceptive efficacy. Studies indicate that while antibiotics can alter the excretion of contraceptive steroids, plasma levels are unchanged, and there is no evidence of ovulation.<sup>580,581,582,583,584</sup> A review of a large number of patients derived from dermatology practices failed to find an increased rate of pregnancy in women on oral contraceptives and being treated with antibiotics (tetracyclines, penicillins, cephalosporins).<sup>585</sup> The anti-HIV drug, etravirine, does not produce important changes in the pharmacodynamics of ethinyl estradiol and norethindrone.<sup>586</sup>

There is good reason to believe that drugs that stimulate the liver's metabolic capacity can affect oral contraceptive efficacy. St. John's wort must be added to this list.<sup>587</sup> On the other hand, a search of a large database failed to discover any evidence that lower-dose oral contraceptives are more likely to fail or to have more drug interaction problems when other drugs are used.<sup>588</sup>

To be cautious, patients on medications that affect liver metabolism should choose an alternative contraceptive. A list, which may not be complete, includes the following:

Carbamazepine (Tegretol)

Felbamate

Lamotrigine

Nevirapine

Oxcarbazepine

Phenobarbital

Phenytoin (Dilantin)

Primidone (Mysoline)

Rifabutin

Rifampicin (Rifampin)

St. John's wort

Topiramate

Vigabatrin

**Possibly** valproic acid, ethosuximide, griseofulvin, and troglitazone

## Other Drug Interactions

Although not extensively documented, there is reason to believe that oral contraceptives potentiate the action of diazepam (Valium), chlordiazepoxide (Librium), tricyclic antidepressants, and theophylline.<sup>589</sup> Thus, lower doses of these agents may be effective in oral contraceptive users. Because of an influence on clearance rates, oral contraceptive users may require larger doses of acetaminophen and aspirin.<sup>590</sup>

# Migraine Headaches

True migraine headaches are more common in women, while tension headaches (90% of all headaches) occur equally in men and women.<sup>591</sup> There have been no well-done studies to determine the impact of oral contraception on the severity of migraine headaches. Patients may report that their headaches are worse or better.

There are two categories of migraine headaches: common migraine, which is migraine without aura, and classic migraine, which is migraine with aura (essentially migraine headaches with visual aura or other neurologic symptoms, occurring in 30% of migraine sufferers). These symptoms begin **before** the headache and resolve with the onset of the headache. Symptoms that occur during headaches, especially photophobia, are not signs of aura. Symptoms that indicate a premonition of a headache, such as light or sound sensitivity, poor concentration, and fatigue occurring 1–2 days before a headache, are also not considered signs of aura.

## Symptoms of migraine with aura:

- Scotomata (blind spots) or blurred vision
- Visualization of bright ragged lines or spots
- Episodes of blindness
- Numbness, paresthesias
- Speech difficulties
- Unilateral symptoms, such as weakness

Because of the seriousness of this potential complication, the onset of visual symptoms or severe headaches requires a response. If the patient is at a higher dose, a move to a low-dose formulation may relieve the headaches; however, this practice has not been studied. True vascular headaches (migraine with aura) are an indication to avoid or discontinue oral contraception. Oral contraceptives should be avoided in women who have migraine with complex or prolonged aura or if additional stroke factors are present (older age, smoking, hypertension, diabetes mellitus, obesity, family history of arterial disease at a young age).<sup>592</sup> Oral contraceptives can be considered in women under age 35, who have migraine **without** aura, and who are otherwise healthy and not smokers.

Migraine headaches, especially with aura, are a risk factor for stroke.<sup>593</sup> The risk is greater in women with hypertension, in smokers, in women with a family history of migraine, and in women with a long history of migraine or with more than 12 attacks per year of migraine with aura.<sup>594,595</sup> Studies with high-dose pills indicated that migraine headaches were linked to a risk of stroke. More recent studies reflecting the use of low-

dose formulations yield mixed results. One failed to find a further increase in stroke in patients with migraine who use oral contraception; another concluded that the use of oral contraception by migraineurs was associated with a fourfold increase of the already increased risk of ischemic stroke.<sup>596,597</sup> The World Health Organization case-control study indicated an increased risk in migraine oral contraceptive users who smoked.<sup>598</sup> Because 20–30% of women experience migraine headaches, one would expect the study populations in the most recent studies of thrombosis to have included substantial numbers of migraineurs. An adverse effect of low-dose oral contraceptives on stroke risk in migraineurs should have manifested itself in the data. The lack of an increased risk of stroke in these studies is reassuring. Nevertheless, it is believed that migraineurs on oral contraceptives have an increased risk of stroke; the absolute risk in a 20-year-old woman is estimated to be 10 per 100,000 and for a 40-year-old woman, 100 per 100,000.<sup>593</sup> Because of the small numbers of young women who have strokes, most studies could not differentiate between migraine with and without aura. However in the American Stroke Prevention in Young Women Study, oral contraceptive use in smokers was associated with an increased risk of stroke in migraineurs with aura.<sup>598</sup>

In some women, a relationship exists between their fluctuating hormone levels during a menstrual cycle and migraine headaches, with the onset of headaches characteristically coinciding with menses (also seen during the pill-free week of oral contraception). We have had personal success (anecdotal to be sure) alleviating headaches by eliminating the menstrual cycle, either with the use of **daily** continuous dosing oral contraceptives or with the daily administration of a progestational agent (such as 10 mg medroxyprogesterone acetate) or the use of depot medroxyprogesterone acetate. An extended regimen, rather than continuous dosing, may also improve menstrual migraine headaches. Some women with migraine headaches have extremely gratifying responses. Women who experience an exacerbation of their headaches with estrogen-progestin contraception should consider one of the progestin-only methods or intrauterine contraception.

**In summary, estrogen-progestin contraception should not be used by women who have migraine with aura. Women who have migraine without aura and who are less than 35 years of age (the risk of stroke increases with age), healthy, and nonsmoking can use combined steroid contraception. Migraineurs without aura over the age of 35 should avoid the pharmacologic use of estrogen.**

# **SUMMARY: ORAL CONTRACEPTIVE USE AND MEDICAL PROBLEMS**

---

# Hypertension

Low-dose oral contraception can be used in women less than age 35 years old with hypertension well controlled by medication and who are otherwise healthy and do not smoke. We recommend the lowest-estrogen dose formulations.



# **Pregnancy-Induced Hypertension**

Women with pregnancy-induced hypertension can use oral contraception as soon as the blood pressure is normal in the postpartum period.

# Uterine Leiomyoma

This is not a contraindication for low-dose oral contraceptives. The administration of low-dose oral contraceptives to women with leiomyomas does not stimulate fibroid growth and is associated with a reduction in menstrual bleeding.<sup>599</sup>

# **Gestational Diabetes**

Low-dose formulations do not produce a diabetic glucose tolerance response in women with previous gestational diabetes, and there is no evidence that combined oral contraceptives increase the incidence of overt diabetes mellitus. We believe that women with previous gestational diabetes can use oral contraception with annual assessment of the fasting glucose level.

# Diabetes Mellitus

Oral contraception can be used by diabetic women who do not smoke and are otherwise healthy (especially an absence of diabetic vascular complications). Women with diabetes and vascular disease or major cardiovascular risk factors should avoid pharmacologic doses of exogenous estrogen.

# **Elective Surgery**

With major surgery and immobilization, including arthroscopy, especially if the patient is overweight, prophylactic treatment should be considered for a current or recent user of oral contraceptives. It is prudent to maintain contraception right up to the performance of a sterilization procedure or any short, outpatient operation.

# Seizure Disorders

Oral contraceptives do not exacerbate epilepsy, and in some women, improvement in seizure control has occurred.<sup>600,601</sup> A potential problem is repeatedly raised regarding antiepileptic drugs that affect liver metabolism, and that is that they may decrease the effectiveness of oral contraception. Some clinicians advocate the use of higher-dose (50 µg estrogen) products; however, no studies have been performed to demonstrate that this higher dose is necessary. Another concern is that moving to a higher-dose product increases the estrogen dose and the risk of side effects. Most importantly, even though studies indicate that some antiepileptic drugs lower steroid levels in oral contraceptive users, ovulation or pregnancies could not be detected in these studies.<sup>602,603,604,605</sup> The efficacy of most antiepileptic drugs is not affected by steroid contraception; however, there is evidence that lamotrigine and valproic acid may need dosage adjustments because of estrogen-induced metabolism.<sup>606,607,608</sup> Consideration should be given to methods that neither affect antiepileptic drug metabolism nor the method affected by the drugs. These include intrauterine contraception with a copper IUD or the levonorgestrel-releasing IUS,<sup>609</sup> long-acting progestin-only methods, barrier methods, and sterilization.

# **Obstructive Jaundice in Pregnancy**

Not all patients with this history will develop jaundice on oral contraception, especially with the low-dose formulations.

# Sickle Cell Disease

Patients with sickle cell trait can use oral contraception. The risk of thrombosis in women with sickle cell disease or sickle C diseases is theoretical (and a medicolegal) concern. We believe effective protection against pregnancy in these patients warrants the use of low-dose oral contraception. In the only long-term (10 years) follow-up report of women with sickle cell disease and using oral contraceptives, no apparent adverse effects were observed (at a time when higher-dose products were prevalent).<sup>610</sup> A study of erythrocyte deformability in women with sickle cell anemia could detect no adverse effects of contraceptive steroids.<sup>611</sup> Keep in mind that depot medroxyprogesterone acetate used for contraception is associated with inhibition of sickling and improvement in anemia in patients with sickle cell disease.<sup>612</sup>



# Gallbladder Disease

Oral contraception use may precipitate a symptomatic attack in women known to have stones or a positive history for gallbladder disease and, therefore, should be done either very cautiously or not at all.

# Mitral Valve Prolapse

Oral contraception use is limited to nonsmoking patients who are asymptomatic (no clinical evidence of regurgitation). There is a small subset of patients with mitral valve prolapse who are at increased risk of thromboembolism. Patients with atrial fibrillation, migraine headaches, or clotting factor abnormalities should consider progestin-only methods or the IUD (prophylactic antibiotics should cover IUD insertion if mitral regurgitation is present).

# Systemic Lupus Erythematosus

Oral contraceptive use can exacerbate systemic lupus erythematosus, and the vascular disease associated with lupus, when present, represents a contraindication to estrogen-containing oral contraceptives.<sup>613</sup> A large case-control study using the General Practice Research Database in the United Kingdom indicated an increased risk of this autoimmune disease in current and recent users of oral contraceptives; however, the only significant increase was in users of 50- $\mu$ g high-dose formulations.<sup>614</sup> The progestin-only methods are a good choice for women with systemic lupus erythematosus. However, in patients with stable or inactive disease, without renal involvement and high antiphospholipid antibodies, low-dose oral contraception can be considered.<sup>615</sup>

In a clinical trial conducted in Mexico City, 162 women with systemic lupus erythematosus were randomized to treatment with one of three contraceptive methods: estrogen-progestin oral contraceptives, oral progestin-only pills, or a copper IUD.<sup>616</sup> Disease activity remained equally mild and stable over 1 year in all three groups. There were no differences in the use of anti-inflammatory drugs. There were four cases of lower-limb thromboses, two in the group receiving oral contraceptives and two with progestin-only pills. All four had low titers of antiphospholipid antibodies. Estrogen-containing contraceptives did not exacerbate systemic lupus erythematosus.

The NIH-supported OC-SELENA (Safety of Estrogens in Lupus Erythematosus National Assessment) trial was a double-blind, randomized trial of 183 women with stable systemic lupus erythematosus treated with either a 35- $\mu$ g ethinyl estradiol oral contraceptive or placebo and followed for 1 year.<sup>617</sup> Lupus flares, the primary endpoint, occurred equally in the two groups. Venous thrombosis did not occur more frequently in the oral contraceptive group. The results indicated that low-dose, estrogen-progestin oral contraceptives can be used by patients with inactive or stable, moderate systemic lupus erythematosus who are at low risk for thrombosis. Patients with high-titer anticardiolipin antibodies, lupus anticoagulant, or previous thrombosis were excluded from the SELENA study. If hormone therapy is to be provided to these patients, some form of chronic anticoagulation should be considered (such as low-dose aspirin).

These studies are important for at least two good reasons. First, there has been a general clinical impression that exogenously administered estrogens would increase lupus disease activity. Second, there are important effects of oral contraceptives that would be beneficial for patients with lupus. These beneficial effects include the following. (1) Contraception is a chief component of care for lupus patients because pregnancy outcome is adversely affected by unstable, active disease. (2) Patients with lupus experience major bone loss and an increase in fractures as an unwanted side

effect of their medical treatment. (3) Estrogen-progestin contraceptives may moderate the intensity of lupus.

# Hyperlipidemia

Because low-dose oral contraceptives have negligible impact on the lipoprotein profile, hyperlipidemia is not an absolute contraindication, with the exception of very high levels of triglycerides (which can be made worse by estrogen). In women with triglyceride levels greater than 250 mg/dL, estrogen should be provided with great caution. If vascular disease is already present, oral contraception should be avoided. If other risk factors are present, especially smoking, oral contraception is not recommended. Dyslipidemic patients who begin oral contraception should have their lipoprotein profiles monitored monthly for a few visits to ensure no adverse impact. If the lipid abnormality cannot be held in control, an alternative method of contraception should be used.<sup>618</sup> If hypertriglyceridemia is the only concern, keep in mind that the triglyceride response to estrogen is rapid. A repeat level should be obtained in 2–4 weeks. **A triglyceride level greater than 750 mg/dL represents an absolute contraindication to estrogen treatment because of the risk of pancreatitis.**

# Smoking

Oral contraception is absolutely contraindicated in smokers over the age of 35. In patients 35 years old and younger, heavy smoking (15 or more cigarettes per day) is a relative contraindication. The relative risk of cardiovascular events is increased for women of all ages who smoke and use oral contraceptives; however, because the actual incidence of cardiovascular events is so low at a young age, the real risk is very low for young women. An ex-smoker (for at least 1 year) should be regarded as a nonsmoker. Risk is only linked to active smoking.

# Hepatic Disease

Oral contraception can be utilized when liver function tests return to normal. Follow-up liver function tests should be obtained after 2–3 months of use.

# Hemorrhagic Disorders

Women with hemorrhagic disorders and women taking anticoagulants can use oral contraception, although the safety of estrogen-progestin methods has not been documented in women who are anticoagulated because of a past history of venous thrombosis. Inhibition of ovulation can avoid the real problem of a hemorrhagic corpus luteum in these patients. A reduction in menstrual blood loss is another benefit of importance. Progestin-only methods do not increase the risk of venous thrombosis. Depot medroxyprogesterone acetate would suppress ovulation and the risk of ovarian hemorrhage, whereas the levonorgestrel-releasing IUD is especially effective for reducing menstrual bleeding.



# Obesity

An obese woman who is otherwise healthy can use low-dose oral contraception. However, there are special considerations associated with obesity:

- Obesity and aging are independent risk factors for venous thrombosis, and case-control studies have indicated this risk adds to that associated with oral contraceptives.<sup>196,619,620</sup> Progestin-only methods should receive serious consideration for use by obese women, especially the levonorgestrel intrauterine system. However, the additional risk with oral contraceptives is less than the risk associated with pregnancy and the postpartum period.<sup>621</sup> **Oral contraceptives with the lowest doses of estrogen should be used for overweight and older women, but progestin-only methods are an even better choice. The same considerations apply to the other methods of estrogen-progestin contraception, the vaginal and transdermal methods.**
- There is modest evidence that hormonal contraceptive failure is increased in overweight women (over 155 lb).<sup>622,623,624,625,626,627</sup> On the other hand, no effect of body weight on oral contraceptive failure was detected in a large, prospective European cohort.<sup>628</sup> Older clinical trials excluded women with high body weight, and for this reason, the effect of body weight on contraception was not well studied. Keep in mind that the positive conclusions regarding failure rates and weight were based on differences of only 2 to 4 pregnancies per 100 women per year. Efficacy in overweight women would still be greater than that with barrier methods. But most importantly, recent clinical trials, especially those with extended regimens, detected no increase in failure rates associated with heavier body weights.<sup>71,85,628,629</sup>
- Obese women on oral contraceptives with a traditional 7-day pill-free period took twice as long (10 days) to achieve a steady-state concentration of the administered progestin, and this was associated with more frequent ovulation.<sup>630</sup> Outliers can take even longer! **We strongly encourage the use of an extended regimen or continuous dosing in these patients.**
- Obesity is increasingly being treated with a method of bariatric surgery. Postoperatively, it is currently recommended that pregnancy be avoided for 12–18 months. Studies indicate that steroid levels after ingestion of oral contraceptives are lower in these patients for at least several years.<sup>631,632</sup> Alternative routes of administration are best for these patients, including the vaginal insertion of oral contraceptives (discussed later), injections, implants, and intrauterine contraception.

# **Benign Breast Disease**

Benign breast disease is not a contraindication for oral contraception; with 2 years of use, the condition may improve.

# **Congenital Heart Disease or Valvular Heart Disease**

Oral contraception is contraindicated only if there is marginal cardiac reserve or a condition that predisposes to thrombosis.

# Polycystic Ovaries and Insulin Resistance

Because older, high-dose oral contraceptives increased insulin resistance, it had been suggested that this treatment should be avoided in anovulatory, overweight women. However, low-dose oral contraceptives have minimal effects on carbohydrate metabolism, and the majority of hyperinsulinemic, hyperandrogenic women can be expected to respond favorably to treatment with oral contraceptives.<sup>633</sup> The administration of a low-dose oral contraceptive to women with extreme obesity and very severe insulin resistance resulted in only a mild deterioration of glucose tolerance.<sup>634</sup> Impressively, in a follow-up study (about 10 years) of women with polycystic ovaries and hyperinsulinism, comparing oral contraceptive users with nonusers, the metabolic parameters not only did not worsen in the users, but they actually improved, including body weight, glucose tolerance, insulin levels, and HDL cholesterol levels, which was in striking contrast to the metabolic worsening observed in the nonusers.<sup>635</sup> This experience supports the safety of oral contraceptive treatment for anovulatory, hyperandrogenic, hyperinsulinemic women.

# Eating Disorders

In patients with eating disorders, bone density correlates with body weight. The bone response to hormone therapy will be impaired as long as an abnormal weight is maintained and low caloric intake persists.<sup>636</sup> The failure to respond to estrogen treatment with an increase in bone density may be due to the adverse bone effects of the hypercortisolism associated with stress disorders. Furthermore, because the pubertal gain in bone density is so significant, individuals who fail to experience this adolescent increase may continue to have a deficit in bone mass despite hormone treatment. Reduced menstrual function for any reason early in life (even beyond adolescence) may leave a residual deficit in bone density that cannot be totally retrieved with resumption of menses or with hormone treatment.<sup>637,638</sup> Steroid contraception can be used in patients with eating disorders, and a failure to gain bone density is a clue that the eating disorder is not resolved.

# **Pituitary Prolactin-Secreting Adenomas**

Low-dose oral contraception can be used in the presence of microadenomas.

# **Infectious Mononucleosis**

Oral contraception can be used as long as liver function tests are normal.

# Inflammatory Bowel Disease

Oral contraceptives are absorbed mainly in the small bowel; women who have an ileostomy after lower bowel surgery have normal steroid absorption with the use of oral contraceptives.<sup>639,640</sup>

The risk of regional enteritis (Crohn disease) was reported to be increased in oral contraceptive users but only in current smokers.<sup>641</sup> Other reports indicated that smoking and oral contraceptive use were independently associated with an increased risk of both incidence and relapse.<sup>642,643</sup> However, these associations were not strong and mostly reflected the use of older, higher-dose formulations. At least one case-control study could detect no link between oral contraceptive use and the incidence of Crohn disease.<sup>644</sup> In a prospective cohort of women with regional enteritis, no adverse impact of oral contraceptives could be detected on the clinical course, specifically on flare-ups.<sup>645</sup>

The impact of low-dose steroid contraception on the risk of inflammatory bowel disease is negligible. In addition, there is no firm reason to withhold these methods from women with these conditions.



# Organ Transplantation

Organ transplantation is followed by immunosuppressive therapy to prevent rejection. Although barrier methods of contraception are usually recommended, there is no reason that postoperative women with good hepatic function and normal blood pressures cannot use steroid contraception.<sup>646,647</sup> The use of steroid contraception in transplant patients will not only provide wanted, effective contraception but also prevent the irregular and heavy menses that are commonly experienced.

# An Alternative Route of Administration

Occasionally, a situation may be encountered when an alternative to oral administration of contraceptive pills is required. For example, patients receiving chemotherapy can have either significant nausea and vomiting or mucositis, both of which would prevent oral drug administration. Pregnancy should be avoided in the 18 months following bariatric surgery, but this time period is associated with gastrointestinal malabsorption. The low-dose oral contraceptives can be administered vaginally. A large clinical trial demonstrated typical contraceptive efficacy with one pill administered vaginally per day.<sup>648</sup> In a comparative study, a major reduction in side effects was associated with vaginal administration.<sup>649</sup>

# ATHLETES AND ORAL CONTRACEPTION

---

Because athletes are often amenorrheic and hypoestrogenic, oral contraceptives provide not only confidence against the risk of an unwanted pregnancy but also estrogen support against bone loss. This is a situation where bone density measurements are worthwhile. A low bone density can help motivate an athlete to take hormone therapy, and a subsequent bone density measurement that reveals a failure of response to estrogen can indicate the presence of a hidden eating disorder.

Competing athletes are often concerned that oral contraceptives could reduce exercise performance. A rationale for the concern can be traced to the physiologic increase in ventilation during pregnancy, mediated by progesterone. Thus, progestin enhancement of ventilatory response could consume energy otherwise available for athletic performance. Indeed, reports have generated conflicting data as measured by laboratory testing. However, experimental studies that simulate athletic events can find no adverse effects on oxygen uptake or respiratory rate.<sup>650</sup> In fact, one study of strenuous exercise in a laboratory setting documented improved aerobic power with increases in time to exhaustion and total work performed in oral contraceptive users.<sup>651</sup> Another study reported decreased soreness, both perceived and with palpation, after exercise in women using oral contraceptives.<sup>652</sup> Oral contraceptive use has no effect on prevalence or severity of low back pain, a common problem among female athletes.<sup>653</sup>

Oral contraceptives have a lot to offer with no serious drawbacks for athletes. In athletes who wish to avoid menstrual bleeding, oral contraceptives can be administered on a daily basis, with no breaks, preventing withdrawal bleeding. Continuous dosing is also a good choice for women in the military. The vaginal and transdermal methods can be used in a similar fashion.

# **THE NONCONTRACEPTIVE BENEFITS OF HORMONAL CONTRACEPTION**

---

The noncontraceptive benefits of low-dose hormonal contraception can be grouped into two main categories: benefits that incidentally accrue when hormonal contraception is specifically utilized for contraceptive purposes and benefits that result from the use of hormonal contraceptives to treat problems and disorders.

The noncontraceptive incidental benefits can be listed as follows:

## **Effective contraception**

**-Less need for induced abortion**

**-Less need for surgical sterilization**

**Less endometrial cancer**

**Less ovarian cancer**

**Less colorectal cancer**

**Fewer ectopic pregnancies**

**More regular menses:**

**-Less flow**

**-Less dysmenorrhea**

**-Less anemia**

**Less salpingitis**

**Less benign breast disease**

**Increased bone density**

**Less endometriosis**

**Possibly less rheumatoid arthritis**

**Possibly protection against atherosclerosis**

**Possibly fewer ovarian cysts**

Many of these benefits have been previously discussed. The low-dose contraceptives are as effective as higher-dose preparations in reducing menstrual flow and the prevalence and severity of dysmenorrhea.<sup>654,655,656</sup> The use of oral contraception is

associated with a lower incidence of endometriosis, although the protective effect is probably limited to current or recent use.<sup>657,658,659</sup> These benefits involving two common gynecologic problems have an important, positive impact on compliance.

Progestational drugs have been used to treat the pain of endometriosis for a long time. In fact, norethindrone and norethynodrel were approved by the FDA for this purpose in 1957, 3 years before approval of the first oral contraceptive. By 1960, 500,000 women were using these agents, although it is unlikely that all had endometriosis or even dysmenorrhea. Therefore, there is an enormous clinical history supporting the use of oral contraceptives for the treatment of endometriosis.

A Japanese double-blind, placebo-controlled, randomized multicenter trial evaluated the use of a low-dose oral contraceptive for the treatment of dysmenorrhea associated with endometriosis.<sup>660</sup> The oral contraceptive, given for 3 out of 4 weeks for 4 cycles, consisted of 35 µg ethinyl estradiol and 1 mg norethindrone. Dysmenorrhea pain interestingly decreased in the placebo group, but the decrease in the oral contraceptive group was about twice as great. The treatment group demonstrated a decrease in pelvic induration that did not achieve statistical significance. Only the treated group demonstrated a reduction in the size of ovarian endometriomas that were larger than 3 cm in diameter at baseline. This Japanese study provides clinical trial data for a low-dose oral contraceptive that confirms years of experience. It is worth noting that a randomized, placebo-controlled trial using a 20 µg estrogen oral contraceptive has documented effective treatment of primary dysmenorrhea in adolescents.<sup>661</sup>

For years, many clinicians have believed that the daily use of an oral contraceptive without a break is more effective for the treatment of endometriosis. A randomized trial with 239 women found equally effective reductions in the recurrence of endometriomas comparing cyclic and continuous oral contraceptive regimens over 2 years.<sup>662</sup>

Low-dose estrogen-progestin contraception is a good first choice to treat pain associated with endometriosis. It is a less expensive option than gonadotropin-releasing hormone (GnRH) analogs, side effects are not a major problem, and treatment can be maintained for long durations. This is also a good option to maintain suppression of endometriosis after surgical or GnRH analog treatment; remember that treatments only suppress and don't cure or eliminate endometriosis. Another advantage of oral contraceptive treatment is that endometriosis may be associated with a slight increase in ovarian cancer (as well as adenocarcinoma in endometriosis tissue), and the profound reduction in the risks of ovarian and endometrial cancer well demonstrated in women without endometriosis is observed equally in women with endometriosis.<sup>663,664</sup> However, endometriosis is often progestin resistant or can acquire resistance; in this setting, oral contraceptives may not be effective, and alternative therapies should be considered as discussed in the chapter on endometriosis.

An Austrian study concluded that osteoporosis occurs later and is less frequent in women who have used long-term oral contraception.<sup>665</sup> Most studies indicate that prior use of oral contraception is associated with higher levels of bone density and that the degree of protection is related to duration of exposure.<sup>666,667,668,669,670,671,672</sup> However, other studies reflecting modern use of low-dose products indicate little impact of oral contraceptive use on bone.<sup>673,674,675</sup> These measurements of bone density are not as important as the clinical outcome: fractures. The available evidence fails to provide a clear-cut picture. Retrospective studies indicated a reduction in fractures in postmenopausal women who had previously used oral contraceptives.<sup>676,677,678,679</sup> In the Royal College of General Practitioners' study, the overall risk of fractures in ever users of oral contraceptives was actually slightly increased.<sup>680</sup> Similar results have been observed in the Oxford Family Planning Association Study.<sup>681</sup> It is likely that the increased risk reflects lifestyle effects among oral contraceptive users, but there was no evidence of a protective effect against fractures. In contrast, a case-control study from Sweden found a reduction in the risk of postmenopausal hip fractures when oral contraceptives (mostly older high-dose products) were used after age 40 by women who were not overweight, with an increasing benefit with increasing duration of use.<sup>682</sup> Previous oral contraceptive users are just now becoming elderly and reaching the age of greatest fracture prevalence. Future studies of postmenopausal women should eventually reveal the accurate relationship between oral contraceptive use and osteoporotic fractures.

The literature on rheumatoid arthritis has been controversial, with studies in Europe finding evidence of protection and studies in North America failing to demonstrate such an effect. An excellent Danish case-control study was designed to answer criticisms of shortcomings in the previous literature.<sup>683</sup> Ever use of oral contraception reduced the relative risk of rheumatoid arthritis by 60%, and the strongest protection was present in women with a positive family history. One meta-analysis concluded that the evidence consistently indicated a protective effect, but that rather than preventing the development of rheumatoid arthritis, oral contraception may modify the course of disease, inhibiting the progression from mild to severe disease, whereas a later meta-analysis concluded there was no evidence of a protective effect.<sup>684,685</sup> More recent studies suggest a reduction in severity with long-term use.<sup>686</sup>

Oral contraceptives are frequently utilized to manage the following problems and disorders:

**Definitely beneficial:**

**-Dysfunctional uterine bleeding**

- Dysmenorrhea**
- Mittelschmerz**
- Endometriosis prophylaxis**
- Acne and hirsutism**
- Hormone therapy for hypothalamic amenorrhea**
- Prevention of menstrual porphyria**
- Control of bleeding (dyscrasias, anovulation)**

**Possibly beneficial:**

- Functional ovarian cysts**
- Premenstrual syndrome**

Oral contraceptives have been a cornerstone for the treatment of anovulatory, dysfunctional uterine bleeding; the only randomized, placebo-controlled trial documented the beneficial impact long recognized by clinicians.<sup>665</sup> For patients who need effective contraception, oral contraceptives are a good choice to provide hormone therapy for amenorrheic patients, as well as to treat dysmenorrhea. Oral contraceptives are also a good choice to provide prophylaxis against the recurrence of endometriosis in a woman who has already undergone more vigorous treatment with surgery or the GnRH analogs.

The low-dose oral contraceptives are effective in treating acne and hirsutism. Suppression of free testosterone levels is comparable with that achieved with higher dosage.<sup>687,688</sup> The beneficial clinical effect is the same with low-dose preparations containing levonorgestrel, previously recognized to cause acne at high dosage.<sup>689</sup> It is likely that all low-dose formulations, through the combined effects of an increase in SHBG and a decrease in testosterone production, produce an overall similar clinical response, especially over time (a year or more).

Oral contraceptives have long been used to speed the resolution of ovarian cysts, but the efficacy of this treatment has not been established. Randomized trials have been performed with women who develop ovarian cysts after induction of ovulation.<sup>690,691,692</sup> No advantage for the contraceptive treatment could be demonstrated. The cysts resolved completely and equally fast in both treated and nontreated groups. Of course, these were functional cysts secondary to ovulation induction, and this experience may not apply to spontaneously appearing cysts. Two short-term (5 and 6 weeks) randomized studies could document no greater effect of oral contraceptive treatment on resolution of spontaneous ovarian cysts when compared with expectant management.<sup>693,694</sup> Clinical

experience (untested by studies) leads us to believe that oral contraception does provide protection in women against the recurrent formation of ovarian cysts.



# CONTINUATION: FAILURE OR SUCCESS?

---

Despite the fact that oral contraception is highly effective, hundreds of thousands of unintended pregnancies occur each year in the United States because of the failure of oral contraception. Worldwide, millions of unintended pregnancies result from poor compliance. In general, the most important determinants of pill failure are age, intention toward a future birth, parity, and marital status. Interestingly, once these factors are accounted for, duration of use, race, ethnicity, and poverty status no longer affected the risk of pill failure.<sup>101</sup> Overall, the failure rate with actual use is as high as 8%. This difference between the theoretical efficacy and actual use largely reflects noncompliance. Noncompliance includes a wide variety of behaviors: failure to fill the initial prescription, failure to continue on the medication, and incorrectly taking oral contraception. Compliance (continuation) is an area in which personal behavior, biology, and pharmacology come together. Oral contraceptive continuation reflects the interaction of these influences. Unfortunately, women who discontinue oral contraception often utilize a less effective method or, worse, fail to substitute another method.

There are three major factors that affect continuation:

1. The experience of side effects, such as breakthrough bleeding and amenorrhea, and perceived experience of “minor” problems, such as headaches, nausea, breast tenderness, bloating, and weight gain. Multiple side effects dramatically and progressively increase the likelihood of discontinuation.<sup>58,695</sup> Because these complaints respond well even to placebo treatment,<sup>696</sup> it is reasonable to expect a favorable response to sensitive and attentive counseling, as well as changing to a different product.
2. Fears and concerns regarding cancer, cardiovascular disease, and the impact of oral contraception on future fertility.
3. Nonmedical issues, such as inadequate instructions on pill taking, complicated pill packaging, difficulties arising from the patient package insert, and, most importantly, contraceptive access and expense.

The information in this chapter is the foundation for good continuation, but the clinician must go beyond the presentation of information and develop an effective means of communicating that information. We recommend the following approach to the clinician-patient encounter as one way to improve continuation with oral contraception.

1. Explain how oral contraception works.
2. Review briefly the risks and benefits of oral contraception, but be careful to put the

risks in proper perspective and to emphasize the safety and noncontraceptive benefits of low-dose oral contraceptives. The risks are low and less than the risks associated with pregnancy.

3. Show and demonstrate to the patient the package of pills she will use.

4. Explain how to take the pills:

-When to start.

-The importance of developing a daily routine to avoid missing pills.

-What to do if pills are missed (identify a backup method).

-Consider the use of an extended regimen (with the potential of greater efficacy).

-Dispense as many packages as possible; evidence indicates that the more packages dispensed, the higher the continuation rate.<sup>94</sup>

5. Review the side effects that can affect continuation, such as amenorrhea, breakthrough bleeding, headaches, weight gain, nausea, etc., and what to do if one or more occurs. The key is to provide anticipatory guidance.

6. Explain the warning signs of potential problems: abdominal or chest pain, trouble breathing, severe headaches, visual problems, leg pain, or swelling.

7. Ask the patient to be sure to call if another clinician prescribes other medications.

8. Ask the patient to repeat critical information to make sure she understands what has been said. Ask if the patient has any questions.

9. Schedule a return appointment in 1–2 months to review understanding and address fears and concerns; a visit at 3 months is too late because most questions and side effects occur early.<sup>63</sup> Inconsistent use of oral contraceptives is more common in women who are new starters.<sup>697</sup>

10. Make sure a line of communication is open to clinician or office personnel. Ask the patient to call for any problem or concern before she stops taking the oral contraceptives.

11. Inform the patient about the availability and the proper use of emergency contraception.

# THE PROGESTIN-ONLY MINIPILL

---

The minipill contains a small dose of a progestational agent and must be taken daily, in a continuous fashion.<sup>698,699</sup> There is no evidence for any major differences in clinical behavior among the available minipill products.

Minipills available worldwide:

1. Micronor, Nor-QD, Noriday, Norod \_\_\_\_\_ 0.350 mg norethindrone
2. Microval, Noregeston, Microlut \_\_\_\_\_ 0.030 mg levonorgestrel
3. Ovrette, Neogest \_\_\_\_\_ 0.075 mg norgestrel (equivalent to 0.0375 mg levonorgestrel)
4. Exluton \_\_\_\_\_ 0.500 mg lynestrenol
5. Femulen \_\_\_\_\_ 0.500 mg ethynodiol diacetate
6. Cerazette \_\_\_\_\_ 0.075 mg desogestrel

# Mechanism of Action

After taking a progestin-only minipill, the small amount of progestin in the circulation (about 25% of that in combined oral contraceptives) will have a significant impact only on those tissues very sensitive to the female sex steroids, estrogen and progesterone. The contraceptive effect is more dependent on endometrial and cervical mucus effects, because gonadotropins are not consistently suppressed. The endometrium involutes and becomes hostile to implantation, and the cervical mucus becomes thick and impermeable. Approximately 40% of patients will ovulate normally.<sup>700,701</sup> Tubal physiology may also be affected, but this is speculative. The progestin-only minipill containing 0.075 mg desogestrel appears to be slightly more effective, probably because it exerts a greater inhibition of ovulation.<sup>702</sup>

**Because of the low dose, the minipill must be taken every day at the same time of the day.** The change in the cervical mucus requires 2–4 hours to take effect, and, most importantly, the impermeability diminishes 22 hours after administration, and by 24 hours, some sperm penetration occurs. Midday administration is recommended.

Ectopic pregnancy is not prevented as effectively as intrauterine pregnancy. Although the overall incidence of ectopic pregnancy is not increased (it is still much lower than the incidence in women not using a contraceptive method), when pregnancy occurs, the clinician must suspect that it is more likely to be ectopic. A previous ectopic pregnancy should not be regarded as a contraindication to the minipill.

There are no significant metabolic effects (lipid levels, carbohydrate metabolism, and coagulation factors remain unchanged),<sup>703,704</sup> and there is an immediate return to fertility on discontinuation. An increase in the risk of venous thrombosis has not been observed in users of progestin-only minipills containing levonorgestrel, norethindrone, or desogestrel.<sup>141,160</sup>

# Efficacy

Failure rates have been documented to range from 1.1 to 9.6 per 100 women in the first year of use.<sup>705</sup> The failure rate is higher in younger women (3.1 per 100 woman-years) compared with women over age 40 (0.3 per 100 woman-years).<sup>706</sup> In motivated women, the failure rate is comparable to the rate (<1 per 100 woman-years) with combination oral contraception.<sup>707,708</sup>

# Pill Taking

The minipill should be started on the first day of menses, and although a backup method for the first 7 days has been the standard recommendation, this extra precaution should not be necessary. A backup method for 7 days is necessary with either a Quick-Start or a Sunday start. The minipill can be started immediately postpartum or after a miscarriage or induced abortion.

Pill taking should be keyed to a daily event to ensure regular administration at the same time of the day. If pills are forgotten or gastrointestinal illness impairs absorption, the minipill should be resumed as soon as possible, and a backup method should be used immediately and until the pills have been resumed for at least 2 days. If 2 or more pills are missed in a row and there is no menstrual bleeding in 4–6 weeks, a pregnancy test should be obtained. **If more than 3 hours late in taking a pill, a backup method should be used for 48 hours. Cerazette (desogestrel) is more forgiving, allowing a 12-hour late time period.**

# Problems

In view of the unpredictable effect on ovulation, it is not surprising that irregular menstrual bleeding is the major clinical problem. The daily progestational impact on the endometrium also contributes to this problem. Patients can expect to have normal, ovulatory cycles (40–50%); short, irregular cycles (40%); or a total lack of cycles ranging from irregular bleeding to spotting and amenorrhea (10%). This is the major reason why women discontinue the minipill method of contraception.<sup>686</sup> Doxycycline, 100 mg b.i.d. for 5 days, is effective in decreasing bleeding associated with progestin-only treatment, apparently by suppressing matrix metalloproteases in endometrial cells.<sup>709</sup>

Women on progestin-only contraception develop more functional, ovarian follicular cysts.<sup>571,710</sup> Nearly all, if not all, regress. This is not a clinical problem of any significance. Women who have experienced frequent ovarian cysts would be happier with methods that effectively suppress ovulation (combined oral contraceptives and depot medroxyprogesterone acetate).

The levonorgestrel minipill may be associated with acne. The mechanism is similar to that seen with Norplant. The androgenic activity of levonorgestrel decreases the circulating levels of SHBG.<sup>711</sup> Therefore, free steroid levels (levonorgestrel and testosterone) will be increased despite the low dose. This is in contrast to the action of combined oral contraception where the effect of the progestin is countered by the estrogen-induced increase in SHBG.

The incidence of the other minor side effects is very low, probably at the same rate that would be encountered with a placebo.

# Clinical Decisions

There are two situations in which excellent efficacy, probably near-total effectiveness, is achieved: lactating women and women over age 40. In lactating women, the contribution of the minipill is combined with prolactin-induced suppression of ovulation, adding up to very effective protection.<sup>712</sup> In women over age 40, reduced fecundity adds to the minipill's effects.

There is another reason why the minipill is a good choice for the breast-feeding woman. There is no evidence for any adverse effect on breast-feeding as measured by milk volume and infant growth and development.<sup>494,495,496</sup> In fact, there is a modest positive impact; women using the minipill breast-feed longer and add supplementary feeding at a later time.<sup>498</sup> Because of the slight positive impact on lactation, the minipill can be started immediately after delivery. A study investigating the impact of early initiation found no adverse effects on breast-feeding.<sup>501</sup>

The minipill is a good choice in situations where estrogen is contraindicated, such as women smokers over the age of 35 or patients with serious medical conditions (diabetes with vascular disease, severe systemic lupus erythematosus,<sup>713</sup> cardiovascular disease). It should be noted that the freedom from estrogen effects, although likely, is presumptive. Substantial data, for example, on associations with vascular disease, blood pressure, and cancer, are not available because relatively small numbers have chosen to use this method of contraception. On the other hand, it is logical to conclude that any of the progestin effects associated with the combination oral contraceptives can be related to the minipill according to a dose-response curve; all effects should be reduced. Both the World Health Organization case-control study and the transnational case-control study could find no indication for increased risks of stroke, myocardial infarction, or venous thromboembolism with oral progestin-only contraceptives.<sup>502,503</sup> No impact can be measured on the coagulation system.<sup>700,714</sup> The minipill can probably be used in women with previous episodes of thrombosis, and the package insert in the United States was revised, eliminating vascular disease as a contraindication.

The minipill is a good alternative for the occasional woman who reports diminished libido on combination oral contraceptives, presumably due to decreased androgen levels. The minipill should also be considered for the few patients who report minor side effects (gastrointestinal upset, breast tenderness, headaches) of such a degree that the combination oral contraceptive is not acceptable.

Because of the relatively low doses of progestin administered, patients using medications that increase liver metabolism should avoid this method of contraception. These drugs include the following:



Carbamazepine (Tegretol)

Felbamate

Lamotrigine

Nevirapine

Oxcarbazepine

Phenobarbital

Phenytoin (Dilantin)

Primidone (Mysoline)

Rifabutin

Rifampicin (Rifampin)

St. John's wort

Topiramate

Vigabatrin

**Possibly** valproic acid, ethosuximide, griseofulvin, and troglitazone

Do the noncontraceptive benefits associated with combination oral contraception apply to the minipill? Studies are unable to help us with this issue, again because of the relatively small numbers of users. However, the progestin impact on cervical mucus, endometrium, and ovulation leads one to think the benefits will be present (reduced risks of pelvic infection, endometrial cancer, and ovarian cancer). Although limited by small numbers, one case-control study indicated that protection against endometrial cancer was even greater with progestin-only pills than with combination oral contraceptives.<sup>715</sup>

Good efficacy with the minipill requires regularity, taking the pill at the same time each day. There is less room for forgetting, and, therefore, the minipill is probably not a good choice for a disorganized adult or for the average adolescent.

# EMERGENCY CONTRACEPTION

# POSTCOITAL

The use of a method after intercourse to prevent pregnancy is commonly called postcoital contraception, or the “morning after” treatment. “Emergency contraception” is a more accurate and appropriate name, indicating the intention to be one-time protection. It is an important option for patients and should be considered when condoms break, when sexual assault occurs, if diaphragms or cervical caps dislodge, or with the lapsed use of any method. In studies at abortion units, 50–60% of the patients would have been suitable for emergency contraception and would have used it if readily available.<sup>716,717</sup> In the United States, it is estimated that emergency contraception could annually prevent 1.7 million unintended pregnancies and the number of induced abortions would decrease by about 40%.<sup>718</sup> Nevertheless, increasing access to emergency contraception has not had an impact on pregnancy or abortion rates in clinical trials, apparently because the actual use is insufficient to have an impact on the general population.<sup>719,720,721</sup> Availability must be accompanied by education and motivation. Clinicians should be aware that younger adolescents can safely use emergency contraception.<sup>722</sup>

Many women do not know of emergency contraception, and it has been difficult to obtain.<sup>717,723</sup> Even if women are aware of this method, accurate and detailed knowledge is lacking.<sup>724</sup> A favorable attitude toward this method requires both knowledge and availability. **The United States by the recent Food and Drug Administration approved over-the-counter levonorgestrel emergency contraception; it is available without a prescription.**

Women who have used emergency contraception are very satisfied with the method and, most importantly, do not express an intention to substitute this method for regular contraception.<sup>725</sup> The use of emergency contraception by adolescents is not associated with an increase in STIs.<sup>726</sup>

The use of large doses of estrogen to provide emergency contraception was pioneered by John Morris and Gertrude van Wageningen at Yale in the 1960s. The initial work in monkeys led to the use of high doses of diethylstilbestrol (25–50 mg/day) and ethinyl estradiol in women.<sup>727</sup> It was quickly appreciated that these extremely large doses of estrogen were associated with a high rate of gastrointestinal side effects. Albert Yuzpe developed a method utilizing a combination oral contraceptive, resulting in an important reduction in dosage.<sup>728</sup> The following treatment regimens, or their generic equivalents, have been documented to be effective:

**Ovral: 2 tablets followed by 2 tablets 12 hours later**

**Allesse: 5 tablets followed by 5 tablets 12 hours later**

**Lo Ovral, Nordette, Levlen, Triphasil, Trilevlen: 4 tablets followed by 4 tablets 12 hours later**

**The method of choice for emergency contraception is levonorgestrel alone**

**Levonorgestrel in a dose of 0.75 mg given twice, 12 hours apart, is more successful and better tolerated than the combination oral contraceptive method.<sup>729,730</sup> In many countries, special packages of 0.75 mg levonorgestrel (Plan B, NorLevo, Vikela) are available for emergency contraception. Greater efficacy and fewer side effects make low-dose levonorgestrel the treatment of choice.**

In the United States, Plan B containing only levonorgestrel (two 0.75-mg tablets) was approved by the FDA for nonprescription sales; one tablet is taken within 120 hours of intercourse and the second 12 hours later. **The two tablets can be combined into a single, one-time dose of 1.5 mg levonorgestrel with no loss of efficacy or increase in side effects.<sup>731,732</sup> The single-dose product, Plan B One-Step, is approved and available in the United States, also without a prescription.** The two-dose product is now available in the United States in a generic version known as Next Choice.

**Clinicians should consider providing advance information and a prescription or an emergency contraceptive kit to patients (a kit can be a simple envelope containing instructions and the appropriate number of oral contraceptives) to be taken when needed.** It would be a major contribution to our efforts to avoid unwanted pregnancies for all patients without contraindications to oral contraceptives to have emergency contraception available for use when needed. In our view, this would be much more effective in reducing the need for abortion than waiting for patients to call. In studies of self-administration, adult women in Scotland and younger women in California increased the use of emergency contraception without adverse effects such as increasing unprotected sex.<sup>733,734,735</sup> Women are able to use this nonprescription access effectively and do not develop a reliance on emergency contraception as a regular method.<sup>736</sup>

# Mechanism and Efficacy

There is strong evidence that treatment with emergency contraception acts primarily by preventing or delaying ovulation and by preventing fertilization.<sup>737,738,739,740,741</sup> Studies have indicated that emergency contraception does not prevent implantation.<sup>742,743,744</sup> Experiments in monkeys and rats could detect no effect of a high dose of levonorgestrel administered postcoitally once fertilization had occurred.<sup>745,746</sup> **The evidence indicates that a postfertilization effect does not contribute to the efficacy of emergency contraception.**<sup>740,745,746,747,748</sup> **Clinicians, pharmacists, and patients can be reassured that treatment with emergency contraception is not an abortifacient.**

Efficacy has been confirmed in large clinical trials and summarized in complete reviews of the literature.<sup>730,749,750,751</sup> Treatment with high doses of estrogen or with levonorgestrel yields a failure rate of approximately 1%, with the combination oral contraceptive, about 2–3%. The failure rate is lowest with high doses of ethinyl estradiol given within 72 hours (0.1%), but the side effects make this a poor choice. In general clinical use, the method with oral contraceptives can reduce the risk of pregnancy by about 75%; this degree of reduction in probability of conception (given the relatively low chance, about 8%, for pregnancy associated with one act of coitus)<sup>752</sup> yields the 2% failure rate measured in clinical studies.<sup>753,754,755</sup>

**Results with levonorgestrel are better, about an 85% reduction in the risk of pregnancy; in the worldwide World Health Organization study, the risk of pregnancy was 60% lower with the levonorgestrel-only method compared with the oral contraceptive method, with less than half as much nausea and vomiting.**<sup>730</sup>

# Treatment Method

Treatment should be initiated as soon after exposure as possible, and the standard recommendation is that it be no later than 120 hours. Careful assessment of the reported experience with emergency contraception indicated that the method is equally effective when started on the first, second, or third day after intercourse (which would allow user-friendly scheduling) and that efficacy extends beyond 72 hours.<sup>756,757</sup> Data from the World Health Organization randomized, clinical trial, however, support the importance of timing, finding a reduction in efficacy after 72 hours, and the greatest protection occurring when the medication is taken within 24 hours of intercourse.<sup>758</sup> Postponing the dose by 12 hours raises the chance of pregnancy by almost 50%. For this reason, the treatment should be initiated as soon as possible after sexual exposure, an important argument in favor of advance provision. Emergency contraception is ineffective in the presence of an established pregnancy. A delay in menses after treatment warrants testing for pregnancy and consideration for the possibility of an ectopic pregnancy.

When using oral contraceptives for emergency contraception, it is worth adding an antiemetic, oral or suppository, to the treatment; a long-acting nonprescription agent, 25 or 50 mg meclizine (Bonine, Dramamine II, Antivert), is recommended, to be taken 1 hour before the emergency contraception treatment. Side effects reflect the high doses used: nausea and vomiting, 50% and 20% with estrogen-progestin oral contraceptives, but only 18% and 4% with levonorgestrel.<sup>730,731,732</sup> Other reactions include breast tenderness, headache, dizziness, and bleeding or spotting in the month after treatment. If a patient vomits within an hour after taking pills, additional pills must be administered as soon as possible. Nausea and vomiting are experienced at such a lower rate with the levonorgestrel-only method that an antiemetic is not necessary.

An analysis of the U.K. General Practice Research Database could find no evidence for an increased risk of venous thromboembolism with the short-term use of oral contraceptives for emergency contraception (indeed, no cases were found for as long as 60 days after use in more than 100,000 episodes of use).<sup>759</sup> Short-term treatment with combined oral contraceptives has been documented to have no effect on clotting factors.<sup>760</sup> **Because of the high dose of estrogen, emergency contraception with combined oral contraceptives should be hesitantly used in women with either a personal or close family history (parent or sibling) of idiopathic thrombotic disease—consideration should be given to the copper IUD or the levonorgestrel-only method.**

A 3-week follow-up visit should be scheduled to assess the result and to counsel for routine contraception. **Even better, a method of contraception should be initiated immediately after the use of emergency contraception to avoid an unwanted**

**pregnancy.**

Could other combination oral contraceptive products be used? A norethindrone-ethinyl estradiol combination was found to be equally effective to the levonorgestrel-ethinyl estradiol formulation, and it is likely that any combination oral contraceptive would be successful.<sup>761</sup> However, this is a moot point because the levonorgestrel-only method is now the treatment of choice. The sustained release of estrogen or progestins from intrauterine (the levonorgestrel-releasing IUS), subdermal, or vaginal delivery methods cannot be used as emergency contraception because systemic hormone concentrations are too low and too slowly achieved.

# The Use of Progesterone Receptor Modulators for Emergency Contraception

## Mifepristone

Mifepristone in a single oral dose of 600 mg is associated with markedly less nausea and vomiting than with oral contraceptives and an efficacy rate of nearly 100%.<sup>762,763</sup> In randomized trials, 10 mg mifepristone was as effective as 25, 50, or 600 mg, preventing about 80–85% of expected pregnancies (the same efficacy and side effects as with the levonorgestrel method), with a slight decrease in efficacy when treatment was delayed to 5 days after intercourse.<sup>731,764,765,766</sup> Because the next menstrual cycle is delayed after mifepristone, contraception should be initiated immediately after treatment. Ironically, mifepristone, around which swirls the abortion controversy, can make an effective contribution to preventing unwanted pregnancies and induced abortions.

## Ulipristal Acetate

Ulipristal acetate (ellaOne) has similar biologic effects as mifepristone and is approved for emergency contraception in Europe and in the United States in a single oral dose of 30 mg. **Randomized trials demonstrated that ulipristal acetate is slightly more effective than the single 1.5-mg dose of levonorgestrel when used within 72 hours after sexual intercourse and even between 72 and 120 hours.**<sup>767,768</sup> Side effects are not severe and similar to those with levonorgestrel. Progesterone receptor modulators like ulipristal acetate and mifepristone suppress ovarian follicular growth and also delay endometrial maturation, manifested by a delay in menstruation after treatment. Ovulation can be temporarily postponed. **Thus, immediate initiation of a contraceptive method after treatment is even more important with the use of these drugs.**

## Other Methods

The three major problems with the available methods of emergency contraception are the high rate of side effects, the need to start treatment within 120 hours after intercourse, and the small, but important, failure rate.

Another method of emergency contraception is the insertion of a copper IUD, anytime during the preovulatory phase of the menstrual cycle and up to 5 days after ovulation. The failure rate (in a small number of studies) is very low, 0.1%.<sup>749,750</sup> This method definitely prevents implantation, but it is not suitable for women who are not candidates for intrauterine contraception, for example, multiple sexual partners or a rape victim. The use of a copper IUD for emergency contraception is expensive, but not if it is retained as an ongoing method of contraception.

The use of danazol for emergency contraception is not effective.<sup>762</sup>



# STEROID CONTRACEPTION FOR OLDER WOMEN

---

The years from age 35 to menopause can be referred to as the transition years. Preventive health care for women is especially important during the transition years. The issues of preventive health care are familiar ones. They include contraception, cessation of smoking, prevention of heart disease and osteoporosis, maintenance of mental well-being (including sexuality), and cancer screening. Management of the transition years should be significantly oriented to preventive health care, and the use of low-dose steroid contraception (including oral, vaginal, and transdermal methods of administration) can now legitimately be viewed as a component of preventive health care. **A discussion of the noncontraceptive health benefits of low-dose oral contraception is especially important with patients in their transition years. This group of women appreciates and understands decisions made with the risk/benefit ratio in mind.**

During this period of time, there are several medical needs that must be addressed: the need for contraception, the management of persistent anovulation, and, finally, menopausal and postmenopausal hormone therapy.

At approximately 40 years of age, the frequency of ovulation decreases. This initiates a period of waning ovarian function called the climacteric, which lasts several years, carrying a woman through decreased fertility and menopause to the postmenopausal years. Prior to menopause, the remaining follicles perform less well. As cycles become irregular, vaginal bleeding occurs at the end of an inadequate luteal phase or after a peak of estradiol without subsequent ovulation and corpus luteum formation. Eventually, many women live through a period of anovulation. Occasionally, corpus luteum formation and function occur, and therefore the older woman is not totally safe from the threat of an unplanned and unexpected pregnancy.

Because of a high rate of unintended pregnancy and less than adequate use of contraception, American women older than age 40 have had for the last two decades a high ratio of abortions per live births, a ratio very similar to that of teenagers.<sup>769</sup> Fortunately, clinicians and patients have recognized that low-dose steroid contraception is safe for healthy, nonsmoking, normotensive older women. Oral contraception fulfills a need, and we would argue that this population of women has a series of benefits to be derived from oral contraception that tilts the risk/benefit ratio to the positive side. The benefits of oral contraceptives reviewed in this chapter are especially pertinent for older women. A case-control study could find no evidence for an increased risk of breast cancer in women who used oral contraceptives **after age 40.**<sup>770</sup>

Despite the widespread teaching and publicity that smoking is a contraindication to oral contraceptive use over the age of 35, more older women who use oral contraceptives smoke and smoke heavily, compared with young women.<sup>206</sup> This strongly implies that older smokers are less than honest with clinicians when requesting oral contraception. **A former smoker must have stopped smoking for at least 12 consecutive months to be regarded as a nonsmoker. Women who have nicotine in their bloodstream obtained from patches or gum should be regarded as smokers.** Smokers over age 35 should continue to be advised that combined estrogen-progestin contraceptives are not a good choice, regardless of the number of cigarettes smoked. In view of the unreported high rate of smoking in older women who use oral contraceptives, clinicians should use 20- $\mu$ g estrogen products for women over age 35.

A product containing 20  $\mu$ g ethinyl estradiol and 150  $\mu$ g desogestrel has been demonstrated in multicenter studies of women over age 30 to have the same efficacy and side effects as pills containing 30 and 35  $\mu$ g of estrogen.<sup>771,772,773</sup> In a randomized study of women over age 30, this formulation was associated with the virtual elimination of any effects on coagulation factors.<sup>733</sup> Indeed, formulations with 20  $\mu$ g ethinyl estradiol have no significant impact on the measurements of clotting factors, even in smokers.<sup>119,120,774,775</sup>

Although it is true that the implied safety of the lowest estrogen dose remains to be documented by epidemiologic studies, it seems clinically prudent to maximize the safety margin in this older age group of women. Although there may be some increase in breakthrough bleeding, we believe that older women who understand the increased safety implicit in the lowest estrogen dose are more willing to endure breakthrough bleeding and maintain continuation. With avoidance of risk factors and use of lowest-dose pills, health risks are negligible for healthy nonsmoking, normotensive women. For healthy nonsmoking women, no specific laboratory screening is necessary beyond that, which is usually incorporated in a program of preventive health care.

As discussed previously, because of reduced fecundity, the minipill achieves near-total efficacy in women over age 40. Therefore, the progestin-only minipill is a good choice for older woman and especially for those women in whom estrogen is contraindicated. Older women are more accepting of irregular menstrual bleeding when they understand its mechanism and, thus, are more accepting of the progestin-only minipill. Older women who are smokers or women with hypertension, migraine headaches with aura, obesity, or vascular disease should be encouraged to use progestin-only methods or an intrauterine device.

# Anovulation and Bleeding

Throughout the transitional period of life, there is a significant incidence of dysfunctional uterine bleeding due to anovulation. While the clinician is usually alerted to this problem because of irregular bleeding, clinician and patient often fail to diagnose anovulation when bleeding is not abnormal in schedule, flow, or duration. As a woman approaches menopause, a more aggressive attempt to document ovulation is warranted. A serum progesterone level measured approximately 1 week before menses is simple enough to obtain and worth the cost. The prompt diagnosis of anovulation (serum progesterone  $<3$  ng/mL) will lead to appropriate therapeutic management that will have a significant impact on the risk of endometrial cancer.

In an anovulatory woman with proliferative or hyperplastic endometrium (unaccompanied by atypia), periodic oral progestin therapy is mandatory, such as 5–10 mg medroxyprogesterone acetate given daily the first 2 weeks of each month. If hyperplasia is already present, follow-up aspiration office curettage after 3–4 months is required. If progestin treatment is ineffective and histologic regression is not observed, more aggressive treatment is warranted. Monthly progestin treatment should be continued until withdrawal bleeding ceases or menopausal symptoms are experienced. These are reliable signs (in effect, a bioassay) indicating the onset of estrogen deprivation and the need for the addition of estrogen in a postmenopausal hormone program.

Two case-control studies, one using data from the WHO Collaborative Study and one using the data from the U.K. General Practice Research Database, assessed the risk of idiopathic venous thrombosis in users of progestins alone for therapeutic purposes and concluded that therapeutic progestins alone may be associated with an increased risk of venous thromboembolism.<sup>776,777</sup> These epidemiologic conclusions were based on extremely small numbers and had very wide confidence intervals. Patients who receive progestin only for therapeutic reasons are probably older and are more likely to have family histories of cardiovascular disease. In addition, a problem of preferential prescribing is probably present in that clinicians are more likely to promote the use of progestin only for women they perceive to be at greater risk of venous thromboembolism. Thus, it is likely that the case groups represented a higher-risk group than the control groups in these reports. For these reasons, we do not believe progestins are associated with an increased risk of venous thromboembolism.

If contraception is desired, the clinician and patient should seriously consider the use of steroid contraception. The anovulatory woman cannot be guaranteed that spontaneous ovulation and pregnancy will not occur. The use of a low-dose oral contraceptive will at the same time provide contraception and prophylaxis against irregular, heavy anovulatory bleeding and the risk of endometrial hyperplasia and

neoplasia. In some patients, oral contraceptive treatment achieves better regulation of menses than monthly progestin administration.

Clinicians often prescribe a traditional postmenopausal hormone regimen to treat a woman with the kind of irregular cycles usually experienced in the perimenopausal years. This addition of exogenous estrogen without a contraceptive dose of progestin when a woman is not amenorrheic or experiencing menopausal symptoms is inappropriate and even risky (exposing the endometrium to excessively high levels of estrogen). **And most importantly, a postmenopausal hormonal regimen does not inhibit ovulation and provide contraception.**<sup>778</sup> The appropriate response is to regulate anovulatory cycles with monthly progestational treatment along with an appropriate contraceptive method or to utilize low-dose steroid contraception. The oral contraceptive that contains 20 µg estrogen provides effective contraception, improves menstrual cycle regularity, diminishes bleeding, and relieves menopausal symptoms.<sup>779</sup>

# When to Change from Oral Contraception to Postmenopausal Hormone Therapy

A common clinical dilemma is when to change from steroid contraception to postmenopausal hormone therapy. It is important to change because even with the lowest-estrogen dose oral contraceptive available, the estrogen dose is fourfold greater than the standard postmenopausal dose, and with increasing age, the dose-related risks with estrogen become significant. One approach to establish the onset of the postmenopausal years is to measure the FSH level, beginning at age 50, on an annual basis, being careful to obtain the blood sample on day 6 or 7 of the pill-free week in a standard regimen (when steroid levels have declined sufficiently to allow FSH to rise). When FSH is greater than 20 IU/L, it is time to change to a postmenopausal hormone program. Because of the variability in FSH levels experienced by women around the menopause, this method is not always accurate.<sup>780,781</sup> Indeed, in some women, FSH will not rise until 2 weeks after the last pill. To wait 2 weeks is not very practical and places the patient at risk for an unwanted pregnancy. However, the pill-free week method is practical and works for most women. Of course, this approach is not usable for women on extended regimens. An empiric approach allows patients to enter their mid-50s on low-dose steroid contraception and then switches to a postmenopausal hormone regimen when she is almost certainly in menopause.

# CONCLUDING THOUGHTS

---

In the 1970s, as epidemiologic data first became available, we emphasized in our teaching and in our communication with patients the risks and dangers associated with oral contraceptives. In the 1990s, with better patient screening and epidemiologic data documenting the effects of low-dose products, we appropriately emphasized the benefits and safety of modern oral contraceptives. In the new millennium, we can with confidence promote the idea that the use of oral contraceptives yields an overall improvement in individual health, and from a public health point of view, the collection of effects associated with oral contraceptives leads to a decrease in the cost of health care.

Contraceptive advice is a component of good preventive health care, and the clinician's approach is a key factor. Patients deserve to know the facts and need help in dealing with the state of the art and those issues clouded by uncertainty. But there is no doubt that patients are influenced in their choices by their clinician's advice and attitude. Although the role of a clinician is to provide the education necessary for the patient to make proper choices, one should not lose sight of the powerful influence exerted by the clinician in the choices ultimately made. Emphasizing the safety and benefits of oral contraceptives, and the contribution of oral contraceptives to individual and public health, allows a clinician to present oral contraception with a very positive attitude, an approach that makes an important contribution to a patient's ability to make appropriate health choices.

# REFERENCES

1. **Simmer HH**, On the history of hormonal contraception. I. Ludwig Haberlandt (1885–1932) and his concept of “hormonal sterilization”, *Contraception* 1:3, 1970.
2. **Simmer HH**, On the history of hormonal contraception. II. Otfried Otto Fellner (1873–19??) and estrogens as antifertility hormones, *Contraception* 3:1, 1971.
3. **Marker RE**, The early production of steroid hormones, *CHOC News*, The Center for History of Medicine, University of Pennsylvania, 4:3, 1987.
4. **Marker RE**, Interview by Jeffrey L. Sturchio at Pennsylvania State University, Chemical Heritage Foundation, Philadelphia, Oral History: Transcript No. 0068, April 17, 1987.
5. **Applezweig N**, The big steroid treasure hunt, *Chemical Week* January 31, 38, 1959.
6. **Lehman FPA**, Early history of steroid chemistry in Mexico: the story of three remarkable men, *Steroids* 57:403, 1992.
7. **Djerassi C**, Problems of manufacture and distribution. The manufacture of steroidal contraceptives: technical versus political aspects, *Proc Roy Soc* 195:175, 1976.
8. **Djerassi C**, *The Pill, Pygmy Chimps, and Degas’ Horse*, Basic Books, New York, 1992.
9. **Djerassi C**, Steroid research at Syntex: “the Pill” and cortisone, *Steroids* 57:631, 1992.
10. **Hench PS, Kendall EC, Slocumb CH, Polley HF**, The effect of a hormone of the adrenal cortex (17-hydroxy-11-dehydrocorticosterone, compound E) and of pituitary adrenocorticotrophic hormone on rheumatoid arthritis, *Proc Staff Meet Mayo Clin* 24:181, 1949.
11. **Rosenkranz G, Pataki J, Djerassi C**, Synthesis of cortisone, *J Am Chem Soc* 76:4055, 1951.
12. **Djerassi C, Miramontes L, Rosenkranz G, Sondheimer F**, Synthesis of 19-nor-17 $\alpha$ -ethynyltestosterone and 19-nor-17 $\alpha$ -methyltestosterone, *J Am Chem Soc* 76:4092, 1954.
13. **Colton FB**, Steroids and “the Pill:” early steroid research at Searle, *Steroids* 57:624, 1992.
14. **Hechter O, Jacobsen RP, Jeanloz R, Levy H, Pincus G, Schenker V**, Pathways of corticosteroid synthesis, *J Clin Endocrinol Metab* 10:827, 1950.
15. **Speroff L**, *A Good Man*. Gregory Goodwin Pincus, Arnica Publishing, Portland, Oregon, 2009, 158.
16. **Ehrenstein M**, Investigations on steroids. VIII. Lower homologs of hormones of the pregnane series: 10-nor-11-desoxycorticosterone acetate and 10-norprogesterone, *J Org Chem* 9:435, 1944.
17. **Tullner WW, Herz R**, High progestational activity of 19-norprogesterone, *Endocrinology* 52:359, 1953.
18. **Herz R, Waite JH, Thomas LB**, Progestational effectiveness of 19-nor-ethinyl-testosterone by oral route in women, *Proc Soc Exp Biol Med* 91:418, 1956.
19. **Tullner WW, Hertz R**, Progestational activity of 19-norprogesterone and 19-nor-ethisterone in the Rhesus monkey, *Proc Soc Exp Biol Med* 94:298, 1957.
20. **Tyler ET**, Comparative evaluation of various types of administration of progesterone, *J Clin Endocrinol Metab* 15:881, 1955.
21. **Zaffaroni A**, Life after Syntex, *Chemical Heritage* 12:2,10,12, 2004.
22. **Pincus GC, Chang MC, Hafez ESE, Zarrow MX, Merrill A**, Effects of certain 19-nor steroids on reproductive processes in animals, *Science* 124:890, 1956.
23. **Rock J, Pincus G, Garcia C-R**, Effects of certain 19-nor steroids on the normal human menstrual cycle, *Science* 124:891, 1956.
24. **Pincus G**, The hormonal control of ovulation and early development, *Postgrad Med* 24:654, 1958.
25. **Pincus G**, *The Control of Fertility*, Academic Press, New York, 1965.
26. **Goldzieher JW**, Selected aspects of the pharmacokinetics and metabolism of ethinyl estrogens and their clinical implications, *Am J Obstet Gynecol* 163: 318, 1990.
27. **Goldzieher J, Stanczyk FZ**, Oral contraceptives and individual variability of circulating levels of ethinyl estradiol and progestins, *Contraception* 78:4, 2008.
28. **Stanczyk FZ, Roy S**, Metabolism of levonorgestrel, norethindrone, and structurally related contraceptive steroids, *Contraception* 42:67, 1990.

29. **Edgren RA**, Progestagens, In: Givens J, ed. *Clinical Uses of Steroids*, Yearbook, Chicago, 1980, p 1.
30. **Kuhnz W, Blode H, Maher M**, Systemic availability of levonorgestrel after single oral administration of a norgestimate-containing combination oral contraceptive to 12 young women, *Contraception* 49:255, 1994.
31. **Stanczyk FZ**, Pharmacokinetics of the new progestogens and influence of gestodene and desogestrel on ethinylestradiol metabolism, *Contraception* 55: 273, 1997.
32. **Hammond GL, Abrams LS, Creasy GW, Natarajan J, Allen JG, Siiteri PK**, Serum distribution of the major metabolites of norgestimate in relation to its pharmacological properties, *Contraception* 67:93, 2003.
33. **Speroff L, DeCherney A**, Evaluation of a new generation of oral contraceptives, *Obstet Gynecol* 81:1034, 1993.
34. **Breitkopf DM, Rosen MP, Young SL, Nagamani M**, Efficacy of second versus third generation oral contraceptives in the treatment of hirsutism, *Contraception* 67:349, 2003.
35. **Kriplani A, Periyasamy AJ, Agarwal N, Kulshrestha V, Kumar A, Ammini AC**, Effect of oral contraceptive containing ethinyl estradiol combined with drospirenone vs. desogestrel on clinical and biochemical parameters in patients with polycystic ovary syndrome, *Contraception* 82:139, 2010.
36. **Foster RH, Wilde MI**, Dienogest, *Drugs* 56:825, 1998.
37. **Wiegatz I, Stahlberg S, Mantehy T, Sänger N, Mittmann K, Lange E, Mellinger U, Kuhl H**, Effects of conventional or extended-cycle regimen of an oral contraceptive containing 30 mcg ethinylestradiol and 2 mg dienogest on various hemostasis parameters, *Contraception* 78:384, 2008.
38. **Endrikat J, Parke S, Trummer D, Schmidt W, Duijkers I, Klipping C**, Ovulation inhibition with four variations of a four-phasic estradiol valerate/dienogest combined oral contraceptive: results of two prospective, randomized, open-label studies, *Contraception* 78:218, 2008.
39. **Ahrendt H-J, Makalová D, Parke S, Mellinger U, Mansour D**, Bleeding pattern and cycle control with an estradiol-based oral contraceptive: a seven-cycle, randomized comparative trial of estradiol valerate/dienogest and ethinyl estradiol/levonorgestrel, *Contraception* 80:436, 2009.
40. **Palacios S, Wildt L, Parke S, Machlitt A, Römer T, Bitzer J**, Efficacy and safety of a novel oral contraceptive based on oestradiol (oestradiol valerate/dienogest): A phase III trial, *Eur J Obstet Gynecol Reprod Biol* 149:57, 2009.
41. **Fuhrmann U, Krattenmacher R, Slater EP, Fritze-meier K-H**, The novel progestin drospirenone and its natural counterpart progesterone: biochemical profile and antiandrogenic potential, *Contraception* 54:243, 1996.
42. **Oelkers W, Helmerhorst FM, Wuttke W, Heithecker R**, Effect of an oral contraceptive containing drospirenone on the renin-angiotensin-aldosterone system in healthy female volunteers, *Gynecol Endocrinol* 14:204, 2000.
43. **Loughlin J, Seeger JD, Eng PM, Foegh M, Clifford CR, Cutone J, Walker AM**, Risk of hyperkalemia in women taking ethinylestradiol/drospirenone and other oral contraceptives, *Contraception* 78:377, 2008.
44. **Freeman EW, Kroll R, Rapkin A, Pearlstein T, Brown C, Parsey K, Zhang P, Patel H, Foegh M; PMS/PMDD Research Group**, Evaluation of a unique oral contraceptive in the treatment of premenstrual dysphoric disorder, *J Womens Health Gend Based Med* 10:561, 2001.
45. **Foidart JM, Wuttke W, Bouw GM, Gerlinger C, Heithecker R**, A comparative investigation of contraceptive reliability, cycle control and tolerance of two monophasic oral contraceptives containing either drospirenone or desogestrel, *Eur J Contracept Reprod Health Care* 5:124, 2000.
46. **Yonkers KA, Brown C, Pearlstein TB, Foegh M, Sampson-Landers C, Rapkin A**, Efficacy of a new low-dose oral contraceptive with drospirenone in premenstrual dysphoric disorder, *Obstet Gynecol* 106:492, 2005.
47. **Due I, Botella J, Bonnet P, Frabol F, Delansorne R, Paris J**, Antiandrogenic properties of nomegestrol acetate, *Drug Res* 45:70, 1995.
48. **Sitruik-Ware RL**, New progestagens for contraceptive use, *Hum Reprod Update* 12:169, 2006.
49. **Rowan JP**, "Estrophasic" dosing: a new concept in oral contraceptive therapy, *Am J Obstet Gynecol* 180:S302, 1999.
50. **Boyd RA, Zegarac EA, Posvar EL, Flack MR**, Minimal androgenic activity of a new oral contraceptive containing norethindrone acetate and graduated doses of ethinyl estradiol, *Contraception* 63:71, 2001.



51. **Gilliam M, Elam G, Maloney JM, Flack MR, Sevilla CL, McLaughlin-Derman R**, Acne treatment with a low-dose oral contraceptive, *Obstet Gynecol* 97(Suppl 1):S9, 2001.
52. **Wiebe ER, Trussell J**, Contraceptive failure related to estimated cycle day of conception relative to the start of the last bleeding episode, *Contraception* 79:178, 2009.
53. **van Heusden AM, Fauser BCJM**, Activity of the pituitary-ovarian axis in the pill-free interval during use of low-dose combined oral contraceptives, *Contraception* 59:237, 1999.
54. **Endrikat J, Müller U, Düsterberg B**, A twelve-month comparative clinical investigation of two low-dose oral contraceptives containing 20 mg ethinylestradiol/75 mg gestodene and 30 mg ethinylestradiol/75 mg gestodene, with respect to efficacy, cycle control, and tolerance, *Contraception* 55:131, 1997.
55. **Rosenberg MJ, Meyers A, Roy V**, Efficacy, cycle control, and side effects of low- and lower-dose oral contraceptives: a randomized trial of 20 micrograms and 35 micrograms estrogen preparations, *Contraception* 60:321, 1999.
56. **Sulak P, Lippman J, Siu C, Massaro J, Goodwin A**, Clinical comparison of triphasic norgestimate/35 mg ethinylestradiol and monophasic norethindrone acetate/20 mg ethinylestradiol: cycle control, lipid effects, and user satisfaction, *Contraception* 59:161, 1999.
57. **Rosenberg MJ, Waugh MS, Stevens CM**, Smoking and cycle control among oral contraceptive users, *Am J Obstet Gynecol* 174:628, 1996.
58. **Rosenberg MJ, Waugh MS**, Oral contraceptive discontinuation: a prospective evaluation of frequency and reasons, *Am J Obstet Gynecol* 179:577, 1998.
59. **Jung-Hoffman C, Kuhl H**, Intra- and interindividual variations in contraceptive steroid levels during 12 treatment cycles: no relation to irregular bleedings, *Contraception* 42:423, 1990.
60. **Willis SA, Kuehl TJ, Spiekerman AM, Sulak P**, Greater inhibition of the pituitary-ovarian axis in oral contraceptive regimens with a shortened hormone-free interval, *Contraception* 74:100, 2006.
61. **Baerwald AR, Adams G, Pierson R**, Characteristics of ovarian follicular wave dynamics in women, *Biol Reprod* 69:1023, 2003.
62. **Goodman AL, Hodgen GD**, The ovarian triad of the primate menstrual cycle, *Recent Prog Horm Res* 39:1, 1983.
63. **Ginther OJ, Beg MA, Bergfelt DR, Danadeu FX, Kot K**, Follicle selection in monovular species, *Biol Reprod* 65:638, 2001.
64. **Killick SR**, Ovarian follicles during oral contraceptive cycles: their potential for ovulation, *Fertil Steril* 52:580, 1989.
65. **Crosignani PG, Testa G, Vegetti W, Parazzini F**, Ovarian activity during regular oral contraceptive use, *Contraception* 54:271, 1996.
66. **Baerwald AR, Olatunbosun OA, Pierson RA**, Ovarian follicular development is initiated during the hormone-free interval of oral contraceptive use, *Contraception* 70:371, 2004.
67. **Pierson RA, Archer DF, Moreau M, Shangold GA, Fisher AC, Creasy GW; for the Ortho Evra™/Evra™ 008 Study Group**, Ortho Evra™/Evra™ versus oral contraceptives: follicular development and ovulation in normal cycles and after an intentional dosing error, *Fertil Steril* 80:34, 2003.
68. **Nakajima ST, Archer DF, Ellman H**, Efficacy and safety of a new 24-day oral contraceptive regimen of norethindrone acetate 1 mg/ethinyl estradiol 20 mg (Loestrin® 24 Fe), *Contraception* 75:16, 2007.
69. **Spona J, Elstein M, Feichtinger W, Sullivan H, Lüdicke F, Müller U, Düsterberg B**, Shorter pill-free interval in combined oral contraceptives decreases follicular development, *Contraception* 54:71, 1996.
70. **Endrikat J, Cronin M, Gerlinger C, Ruebig A, Schmidt W, Dusterberg B**, Open, multicenter comparison of efficacy, cycle control, and tolerability of a 23-day oral contraceptive regimen with 20 microg ethinyl estradiol and 75 microg gestodene and a 21-day regimen with 20 microg ethinyl estradiol and 150 microg desogestrel, *Contraception* 64:201, 2001.
71. **Endrikat J, Cronin M, Gerlinger C, Ruebig A, Schmidt W, Dusterberg B**, Double-blind, multicenter comparison of efficacy, cycle control, and tolerability of a 23-day versus a 21-day low-dose oral contraceptive regimen containing 20 microg ethinyl estradiol and 75 microg gestodene, *Contraception* 64:99, 2001.
72. **Sullivan H, Furniss H, Spona J, Elstein M**, Effect of 21-day and 24-day oral contraceptive regimens

- containing gestodene (60 mg) and ethinyl estradiol (15 mg) on ovarian activity, *Fertil Steril* 72:115, 1999.
73. **Gestodene Study Group 324**, Cycle control, safety and efficacy of a 24-day regimen of gestodene 60 microg/ethinylestradiol 15 microg and a 21-day regimen of desogestrel 150 microg/ethinylestradiol 20 microg, *Eur J Contracept Reprod Health Care* 4(Suppl 2):17, 1999.
  74. **Fruzzetti F, Genazzani AR, Ricci C, De Negri F, Bersi C, Carmassi F**, A 12-month clinical investigation with a 24-day regimen containing 15 microg ethinylestradiol plus 60 microg gestodene with respect to hemostasis and cycle control, *Contraception* 63:303, 2001.
  75. **Klipping C, Marr J, Korner P**, Ovulation inhibition effects of two low-dose oral contraceptive dosing regimens following intentional dosing errors (abstract), *Obstet Gynecol* 107(Suppl):495, 2006.
  76. **Miller L, Notter KM**, Menstrual reduction with extended use of combination oral contraceptive pills: randomized controlled trial, *Obstet Gynecol* 98:771, 2001.
  77. **Kwiecien M, Edelman A, Nichols MD, Jensen JT**, Bleeding patterns and patient acceptability of standard or continuous dosing regimens of a low-dose oral contraceptive: a randomized trial, *Contraception* 67:9, 2003.
  78. **Miller L, Hughes JP**, Continuous combination oral contraceptive pills to eliminate withdrawal bleeding: a randomized trial, *Obstet Gynecol* 101:653, 2003.
  79. **Elomaa K, Rolland R, Brosens I, Moorrees M, Deprest J, Tuominen J, Lähteenmäki P**, Omitting the first oral contraceptive pills of the cycle does not automatically lead to ovulation, *Am J Obstet Gynecol* 179:41, 1998.
  80. **Creinin MD, Lippman JS, Eder SE, Godwin AJ, Olson W**, The effect of extending the pill-free interval on follicular activity: triphasic norgestimate/35 mg ethinyl estradiol versus monophasic levonorgestrel/20 mg ethinyl estradiol, *Contraception* 66:147, 2002.
  81. **Baerwald AR, Olatunbosun OA, Pierson RA**, Effects of oral contraceptives administered at defined stages of ovarian follicular development, *Fertil Steril* 86:27, 2006.
  82. **Anderson FD, Hait H; the Seasonale-301 Study Group**, A multicenter, randomized study of an extended cycle oral contraceptive, *Contraception* 68:89, 2003.
  83. **Vandever MA, Kuehl TJ, Sulak PJ, Witt I, Coffee A, Wincek TJ, Reape KZ**, Evaluation of pituitary-ovarian axis suppression with three oral contraceptive regimens, *Contraception* 77:162, 2008.
  84. **Kaunitz AM, Portman DJ, Hait H, Reape KZ**, Adding low-dose estrogen to the hormone-free interval: impact on bleeding patterns in users of a 91-day extended regimen oral contraceptive, *Contraception* 79:350, 2009.
  85. **Kroll R, Reape KZ, Margolis M**, The efficacy and safety of a low-dose, 91-day, extended-regimen oral contraceptive with continuous ethinyl estradiol, *Contraception* 81:41, 2010.
  86. **Edelman AB, Koontz SL, Nichols MD, Jensen JT**, Continuous oral contraceptives. Are bleeding patterns dependent on the hormones given?, *Obstet Gynecol* 107:657, 2006.
  87. **Archer DF, Jensen JT, Johnson JV, Borisute H, Grubb GS, Constantine GD**, Evaluation of a continuous regimen of levonorgestrel/ethinyl estradiol: Phase 3 study results, *Contraception* 74:439, 2006.
  88. **Teichmann A, Apter D, Emerich J, Greven K, Klasa-Mazurkiewicz D, Melis GB, Spaczynski M, Grubb GS, Constantine G, Spielmann D**, Continuous, daily levonorgestrel/ethinyl estradiol vs. 21-day, cyclic levonorgestrel/ethinyl estradiol: efficacy, safety and bleeding in a randomized, open-label trial, *Contraception* 80:504, 2009.
  89. **Coffee AL, Kuehl TJ, Willis S, Sulak PJ**, Oral contraceptives and premenstrual symptoms: comparison of a 21/7 and extended regimen, *Am J Obstet Gynecol* 195:1311, 2006.
  90. **Coffee AL, Sulak PJ, Kuehl TJ**, Long-term assessment of symptomatology and satisfaction of an extended oral contraceptive regimen, *Contraception* 75:444, 2007.
  91. **Sulak P, Willis S, Kuehl TJ, Coffee A, Clark J**, Headaches and oral contraceptives: impact of eliminating the standard 7-day placebo interval, *Headache* 47:27, 2007.
  92. **Archer DF, Kovalevsky G, Ballagh SA, Grubb GS**, Ovarian activity and safety of a novel levonorgestrel/ethinyl estradiol continuous oral contraceptive regimen, *Contraception* 80:245, 2009.
  93. **Davis AR, Kroll R, Soltes B, Zhang N, Grubb GS, Constantine GD**, Occurrence of menses or pregnancy after cessation of a continuous oral contraceptive, *Fertil Steril* 89:1059, 2008.

94. **Alexander NJ, Baker E, Kaptein M, Karck U, Miller L, Zampaglione E**, Why consider vaginal drug administration?, *Fertil Steril* 82:1, 2004.
95. **Timmer CJ, Mulders TM**, Pharmacokinetics of etonogestrel and ethinylestradiol released from a combined contraceptive vaginal ring, *Clin Pharmacokinet* 39:233, 2000.
96. **Weisberg E, Brache V, Alvarez F, Massai R, Mishell Jr DR, Apter D, Gale J, Sivin I, Tsong Y-Y, Fraser IS**, Clinical performance and menstrual bleeding patterns with three dosage combinations of a Nestorone progestogen/ethinyl estradiol contraceptive vaginal ring used on a bleeding-signaled regimen, *Contraception* 72:46, 2005.
97. **Rad M, Kluft C, Ménard J, Burggraaf J, de Kam ML, Meijer P, Sivin I, Sitruik-Ware RL**, Comparative effects of a contraceptive vaginal ring delivering a nonandrogenic progestin and continuous ethinyl estradiol and a combined oral contraceptive containing levonorgestrel on hemostasis variables, *Am J Obstet Gynecol* 195:72, 2006.
98. **Jensen JT, Edelman AB, Chen BA, Archer DF, Barnhart KT**, et al., Continuous dosing of a novel contraceptive vaginal ring releasing Nestorone and estradiol: pharmacokinetics from a dose-finding study, *Contraception* 97:422, 2018.
99. **Roumen FJME, Apter D, Mulders TMT, Dieben TOM**, Efficacy, tolerability and acceptability of a novel contraceptive vaginal ring releasing etonogestrel and ethinyl estradiol, *Hum Reprod* 16:469, 2001.
100. **Miller L, Verhoeven CH, Hout J**, Extended regimens of the contraceptive vaginal ring: a randomized trial, *Obstet Gynecol* 106:473, 2005.
101. **Mulders TM, Dieben TO**, Use of the novel combined contraceptive vaginal ring NuvaRing for ovulation inhibition, *Fertil Steril* 75:865, 2001.
102. **Sulak PJ, Smith V, Coffee A, Witt I, Kuehl AL, Kuehl TJ**, Frequency and management of breakthrough bleeding with continuous use of the transvaginal contraceptive ring: a randomized controlled trial, *Obstet Gynecol* 112:563, 2008.
103. **Dieben TOM, Roumen FJME, Apter D**, Efficacy, cycle control, and user acceptability of a novel combined contraceptive vaginal ring, *Obstet Gynecol* 100: 585, 2002.
104. **Oddsson K, Leifels-Fischer B, de Melo NR, Wiel-Masson D, Benedetto C, Verhoeven CH, Dieben TO**, Efficacy and safety of a contraceptive vaginal ring (NuvaRing) compared with a combined oral contraceptive: a 1-year randomized trial, *Contraception* 71:176, 2005.
105. **Szarewski A**, High acceptability and satisfaction with NuvaRing use, *Eur J Contracept Reprod Health Care* 7:31, 2002.
106. **Merki-Feld GS, Hund M**, Clinical experience with NuvaRing in daily practice in Switzerland: cycle control and acceptability among women of all reproductive ages, *Eur J Contracept Reprod Health Care* 12:240, 2007.
107. **Brucker C, Karck U, Merkle E**, Cycle control, tolerability, efficacy and acceptability of the vaginal contraceptive ring, NuvaRing: results of clinical experience in Germany, *Eur J Contracept Reprod Health Care* 13:31, 2008.
108. **Dittrich R, Parker L, Rosen JB, Shangold G, Creasy GW, Fisher AC; for the Ortho Evra/Evra 001 Study Group**, Transdermal contraception: evaluation of three transdermal norelgestromin/ethinyl estradiol doses in a randomized multicenter, dose-response study, *Am J Obstet Gynecol* 186:15, 2002.
109. **Zacur HA, Hedon B, Mansour D, Shangold GA, Fisher AC, Creasy GW**, Integrated summary of Ortho Evra™/Evra™ contraceptive patch adhesion in varied climates and conditions, *Fertil Steril* 77(Suppl 2):S32, 2002.
110. **Audet M-C, Moreau M, Koltun WD, Waldbaum AS, Shangold G, Fisher AC, Creasy GW; for the ORTHO EVRA/EVRA 004 Study Group**, Evaluation of contraceptive efficacy and cycle control of a transdermal contraceptive patch vs an oral contraceptive. A randomized controlled trial, *JAMA* 285:2347, 2001.
111. **Smallwood GH, Meador ML, Lenihan JP Jr, Shangold GA, Fisher AC, Creasy GW; for the ORTHO EVRA/EVRA 002 Study Group**, Efficacy and safety of a transdermal contraceptive system, *Obstet Gynecol* 98:799, 2001.
112. **Abrams LS, Skee DM, Natarajan J, Wong FA**, Pharmacokinetic overview of Ortho Evra™/Evra™, *Fertil Steril* 77(Suppl 2):S3, 2002.

113. **Abrams LS, Skee DM, Natarajan J, Wong FA, Lasseter KC**, Multiple-dose pharmacokinetics of a contraceptive patch in healthy women participants, *Contraception* 64:287, 2001.
114. **Abrams LS, Skee DM, Natarajan J, Wong FA, Anderson BD**, Pharmacokinetics of a contraceptive patch (Evra/Ortho Evra) containing norelgestromin and ethinylloestradiol at four application sites, *Br J Clin Pharmacol* 53:141, 2002.
115. **Abrams LS, Skee DM, Wong FA, Anderson NJ, Leese PT**, Pharmacokinetics of norelgestromin and ethinyl estradiol from two consecutive contraceptive patches, *J Clin Pharmacol* 41:1232, 2001.
116. **Abrams LS, Skee DM, Natarajan J, Wong FA, Leese PT, Creasy GW, Shangold MM**, Pharmacokinetics of norelgestromin and ethinyl estradiol delivered by a contraceptive patch (Ortho Evra/Evra) under conditions of heat, humidity, and exercise, *J Clin Pharmacol* 41:1301, 2001.
117. **Foster DG, Parvateneni R, de Bocanegra HT, Lewis C, Bradsberry M, Darney P**, Number of oral contraceptive pill packages dispensed, method continuation, and costs, *Obstet Gynecol* 108:1107, 2006.
118. **Bylander A, Lind K, Goksor M, Billig H, Larsson DG**, The classical progesterone receptor mediates the rapid reduction of fallopian tube ciliary beat frequency by progesterone, *Reprod Biol Endocrinol* 11:33, 2013.
119. **Bylander A, Gunnarsson L, Shao R, Billig H, Larsson DG**, Progesterone-mediated effects on gene expression and oocyte-cumulus complex transport in the mouse fallopian tube, *Reprod Biol Endocrinol* 13:40, 2015.
120. **Rossmannith WG, Steffens D, Schramm G**, A comparative randomized trial on the impact of two low-dose oral contraceptives on ovarian activity, cervical permeability, and endometrial receptivity, *Contraception* 56:23, 1997.
121. **Sparrow MJ**, Pill method failures, *N Z Med J* 100:102, 1987.
122. **Hansen TH, Lundvall F**, Factors influencing the reliability of oral contraceptives, *Acta Obstet Gynecol Scand* 76:61, 1997.
123. **Fu H, Darroch JE, Haas T, Ranjit N**, Contraceptive failure rates: new estimates from the 1995 National Survey of Family Growth, *Fam Plann Perspect* 31:58, 1999.
124. **Kost K, Singh S, Vaughan B, Trussell J, Bankole A**, Estimates of contraceptive failure from the 2002 National Survey of Family Growth, *Contraception* 77:10, 2008.
125. **Archer DF, Bigrigg A, Smallwood GH, Shangold GA, Creasy GW, Fisher AC**, Assessment of compliance with a weekly contraceptive patch (Ortho Evra™/Evra™) among North American women, *Fertil Steril* 77(Suppl 2):S27, 2002.
126. **Urdl W, Apter D, Alperstein A, Koll P, Schönian S, Bringer J, Fisher AC, Preik M; ORTHO EVRA/EVRA 003 Study Group**, Contraceptive efficacy, compliance and beyond: factors related to satisfaction with once-weekly transdermal compared with oral contraception, *Eur J Obstet Gynecol Reprod Biol* 121:202, 2005
127. **Gilliam ML, Neustadt A, Kozloski M, Mistretta S, Tilmon S, Godfrey E**, Adherence and acceptability of the randomized contraceptive ring compared with the pill among students: a randomized clinical trial, *Obstet Gynecol* 115:503, 2010.
128. **Jain S, Vaqid NB, Narang Y, Suneja A, Guleria K**, A randomised controlled trial comparing the efficacy and side-effects of intravaginal ring (NuvaRing®) with combined oral hormonal preparation in dysfunctional uterine bleeding, *J Clin Diagn Res* 10:1, 2016.
129. **Martinelli I, Sacchi E, Landi G, Taioli E, Duca F, Mannucci PM**, High risk of cerebral-vein thrombosis in carriers of a prothrombin-gene mutation and in users of oral contraceptives, *N Engl J Med* 338:1793, 1998.
130. **Hajjar KA**, Factor V Leiden: an unselfish gene?, *N Engl J Med* 331:1585, 1994.
131. **Svensson PJ, Dahlbäck B**, Resistance to activated protein C as a basis for venous thrombosis, *N Engl J Med* 330:517, 1994.
132. **Zöller B, Hillarp A, Berntorp E, Dahlbäck B**, Activated protein C resistance due to a common factor V gene mutation is a major risk factor for venous thrombosis, *Annu Rev Med* 48:45, 1997.
133. **Rees DC, Cox M, Clegg JB**, World distribution of factor V Leiden, *Lancet* 346:1133, 1995.
134. **Zivelin A, Griffin JH, Xu X, Pabinger I, Samama M, Conard J, Brenner B, Eldor A, Seligsohn U**, A single genetic origin for a common Caucasian risk factor for venous thrombosis, *Blood* 89:397, 1997.

135. **Poort SR, Rosendaal FR, Reitsma PH, Bertina RM**, A common genetic variation in the 3'-untranslated region of the prothrombin gene is associated with elevated plasma prothrombin levels and an increase in venous thrombosis, *Blood* 88:3698, 1996.
136. **Rosendaal FR, Doggen CJM, Zivelin A, Arruda VR, Aiach M, Siscovick DS, Hillarp H, Watzke HH, Bernardi F, Cumming AM, Preston FE, Reitsma PH**, Geographic distribution of the 20210 G to A prothrombin variant, *Thromb Haemost* 79:706, 1998.
137. **Martinelli I, Taioli E, Bucciarelli P, Akhavan S, Mannucci PM**, Interaction between the G20210A mutation of the prothrombin gene and oral contraceptive use in deep vein thrombosis, *Arterioscler Thromb Vasc Biol* 19:700, 1999.
138. **Legnani C, Cosmi B, Valdre L, Boggian O, Bernardi F, Coccheri S, Palareti G**, Venous thromboembolism, oral contraceptives and high prothrombin levels, *J Thromb Haemost* 1:112, 2003.
139. **Meade TW**, Oral contraceptives, clotting factors, and thrombosis, *Am J Obstet Gynecol* 142:758, 1982.
140. **The Oral Contraceptive and Hemostasis Study Group**, The effect of seven monophasic oral contraceptive regimens on hemostatic variables: conclusions from a large randomized multicenter study, *Contraception* 67:173, 2003.
141. **Jespersen J, Petersen KR, Skouby SO**, Effects of newer oral contraceptives on the inhibition of coagulation and fibrinolysis in relation to dosage and type of steroid, *Am J Obstet Gynecol* 163:396, 1990.
142. **Notelovitz M, Kitchens CS, Khan FY**, Changes in coagulation and anticoagulation in women taking low-dose triphasic oral contraceptives: a controlled comparative 12-month clinical trial, *Am J Obstet Gynecol* 167:1255, 1992.
143. **Schlit AF, Grandjean P, Donnez J, Lavenne E**, Large increase in plasmatic 11-dehydro-TXB2 levels due to oral contraceptives, *Contraception* 51:53, 1995.
144. **Fruzzetti F, Ricci C, Fioretti P**, Haemostasis profile in smoking and nonsmoking women taking low-dose oral contraceptives, *Contraception* 49:579, 1994.
145. **Kluft C, Meijer P, Laguardia KD, Fisher AC**, Comparison of a transdermal contraceptive patch vs. oral contraceptives on hemostasis variables, *Contraception* 77:77, 2008.
146. **Basdevant A, Conard J, Pelissier C, Guyene T-T, Lapousterle C, Mayer M, Guy-Grand B, Degrelle H**, Hemostatic and metabolic effects of lowering the ethinyl-estradiol dose from 30 mcg to 20 mcg in oral contraceptives containing desogestrel, *Contraception* 48:193, 1993.
147. **Winkler UH, Schindler AE, Endrikat J, Düsterberg B**, A comparative study of the effects of the hemostatic system of two monophasic gestodene oral contraceptives containing 20 mg and 30 mg ethinylestradiol, *Contraception* 53:75, 1996.
148. **Croft P, Hannaford PC**, Risk factors for acute myocardial infarction in women: evidence from the Royal College of General Practitioners' oral contraception study, *Br Med J* 298:165, 1989.
149. **Rosenberg L, Palmer JR, Lesko SM, Shapiro S**, Oral contraceptive use and the risk of myocardial infarction, *Am J Epidemiol* 131:1009, 1990.
150. **Stampfer MJ, Willett WC, Colditz GA, Speizer FE, Hennekens CH**, Past use of oral contraceptives and cardiovascular disease: a meta-analysis in the context of the Nurses' Health Study, *Am J Obstet Gynecol* 163:285, 1990.
151. **Colditz GA; the Nurses' Health Study Research Group**, Oral contraceptive use and mortality during 12 years of follow-up: the Nurses' Health Study, *Ann Intern Med* 120:821, 1994.
152. **Beral V, Hermon C, Kay C, Hannaford P, Darby S, Reeves G**, Mortality associated with oral contraceptive use: 25-year follow-up of cohort of 46,000 women from Royal College of General Practitioners' oral contraception study, *Br Med J* 318:96, 1999.
153. **Vessey M, Painter R, Yeates D**, Mortality in relation to oral contraceptive use and cigarette smoking, *Lancet* 362:185, 2003.
154. **Böttiger LE, Boman G, Eklund G, Westerholm B**, Oral contraceptives and thromboembolic disease: effects of lowering oestrogen content, *Lancet* 1:1097, 1980.
155. **Gerstman BB, Piper JM, Tomita DK, Ferguson WJ, Stadel BV, Lundin FE**, Oral contraceptive estrogen dose and the risk of deep venous thromboembolic disease, *Am J Epidemiol* 133:32, 1991.

156. **Vessey M, Mant D, Smith A, Yeates D**, Oral contraceptives and venous thromboembolism: findings in a large prospective study, *Br Med J* 292:526, 1986.
157. **Helmrich SP, Rosenberg L, Kaufman DW, Strom B, Shapiro S**, Venous thromboembolism in relation to oral contraceptive use, *Obstet Gynecol* 69:91, 1987.
158. **Thorogood M, Mann J, Murphy M, Vessey M**, Risk factors for fatal venous thromboembolism in young women: a case-control study, *Int J Epidemiol* 21:48, 1992.
159. **Rosenberg L, Hennekens CH, Rosner B, Belanger C, Rothman KH, Speizer FE**, Oral contraceptive use in relation to nonfatal myocardial infarction, *Am J Epidemiol* 111:59, 1980.
160. **Royal College of General Practitioners' Oral Contraceptive Study**, Incidence of arterial disease among oral contraceptive users, *J Roy Coll Gen Pract* 33:75, 1983.
161. **Lidegaard Ø**, Oral contraception and risk of a cerebral thromboembolic attack: results of a case-control study, *Br Med J* 306:956, 1993.
162. **Lawson DH, Davidson JF, Jick H**, Oral contraceptive use and venous thromboembolism: absence of an effect of smoking, *Br Med J* 2:729, 1977.
163. **Petitti DB, Wingerd J, Pellegrin F, Ramcharan S**, Oral contraceptives, smoking, and other factors in relation to risk of venous thromboembolic disease, *Am J Epidemiol* 108:480, 1978.
164. **Royal College of General Practitioners**, Oral contraceptive study: oral contraceptives, venous thrombosis, and varicose veins, *J Roy Coll Gen Pract* 28:393, 1978.
165. **Porter JB, Hershel J, Walker AM**, Mortality among oral contraceptive users, *Obstet Gynecol* 70:29, 1987.
166. **WHO Collaborative Study of Cardiovascular Disease and Steroid Hormone Contraception**, Venous thromboembolic disease and combined oral contraceptives: results of international multicentre case-control study, *Lancet* 346:1575, 1995.
167. **WHO Collaborative Study of Cardiovascular Disease and Steroid Hormone Contraception**, Effect of different progestagens in low oestrogen oral contraceptives on venous thromboembolic disease, *Lancet* 346:1582, 1995.
168. **Spitzer WO, Lewis MA, Heinemann LAJ, Thorogood M, MacRae KD; on behalf of the Transnational Research Group on Oral Contraceptives and the Health of Young Women**, Third generation oral contraceptives and risk of venous thromboembolic disorders: an international case-control study, *Br Med J* 312:83, 1996.
169. **Jick H, Jick SS, Gurewich V, Myers MW, Vasilakis C**, Risk of idiopathic cardiovascular death and nonfatal venous thromboembolism in women using oral contraceptives with differing progestagen components, *Lancet* 348:1589, 1995.
170. **Jick H, Kaye JA, Vasilakis-Scaramozza C, Jick SS**, Risk of venous thromboembolism among users of third generation oral contraceptives compared with users of oral contraceptives with levonorgestrel before and after 1995: cohort and case-control analysis, *Br Med J* 321:1190, 2000.
171. **Jick SJ, Kaye JA, Russmann S, Jick H**, Risk of nonfatal venous thromboembolism with oral contraceptives containing norgestimate or desogestrel compared with oral contraceptives containing levonorgestrel, *Contraception* 73:566, 2006.
172. **Bloemenkamp KWM, Rosendaal FR, Helmerhorst FM, Büller HR, Vandenbroucke JP**, Enhancement by factor V Leiden mutation of risk of deep-vein thrombosis associated with oral contraceptives containing a third-generation progestagen, *Lancet* 348:1593, 1995.
173. **Lidegaard Ø, Edström B, Kreiner S**, Oral contraceptives and venous thromboembolism. A case-control study, *Contraception* 5:291, 1998.
174. **Lidegaard Ø, Edström B, Kreiner S**, Oral contraceptives and venous thromboembolism: a five-year national case-control study, *Contraception* 65:187, 2002.
175. **Farmer RDT, Lawrenson RA, Thompson CR, Kennedy JG, Hambleton IR**, Population-based study of risk of venous thromboembolism associated with various oral contraceptives, *Lancet* 349:83, 1997.
176. **Farmer RD, Lawrenson RA, Todd JC, Williams TJ, MacRae KD, Tyrer F, Leydon GM**, A comparison of the risks of venous thromboembolic disease in association with different combined oral contraceptives, *Br J Clin Pharmacol* 49:580, 2000.

177. **Farmer RDT, Todd J-C, Lewis MA, MacRae KD, Williams TJ**, The risks of venous thromboembolic disease among German women using oral contraceptives: a database study, *Contraception* 57:67, 1998.
178. **Farmer RDT, Williams TJ, Simpson EL, Nightingale AL**, Effect of 1995 pill scare on rates of venous thromboembolism among women taking combined oral contraceptives: analysis of General Practice Research Database, *Br Med J* 321:477, 2000.
179. **Suissa S, Blais L, Spitzer WO, Cusson J, Lewis M, Heinemann L**, First-time use of newer oral contraceptives and the risk of venous thromboembolism, *Contraception* 56:141, 1997.
180. **Suissa S, Spitzer WO, Rainville B, Cusson J, Lewis M, Heinemann L**, Recurrent use of newer oral contraceptives and the risk of venous thromboembolism, *Hum Reprod* 15:817, 2000.
181. **Todd J, Lawrenson R, Farmer RD, Williams TJ, Leydon GM**, Venous thromboembolic disease and combined oral contraceptives: a re-analysis of the MediPlus database, *Hum Reprod* 14:1500, 1999.
182. **Heinemann LAJ, Lewis MA, Assmann A, Thiel C**, Case-control studies on venous thromboembolism: bias due to design? A methodological study on venous thromboembolism and steroid hormone use, *Contraception* 65:207, 2002.
183. **Heinemann LAJ, Lewis MA, Assman A, Gravens L, Guggenmoos-Holzmann I**, Could preferential prescribing and referral behaviour of physicians explain the elevated thrombosis risk found to be associated with third generation oral contraceptives?, *Pharmacoepidemiol Drug Saf* 5:285, 1996.
184. **Jamin C, de Mouzon J**, Selective prescribing of third generation oral contraceptives (OCs), *Contraception* 54:55, 1996.
185. **Van Lunsen WH**, Recent oral contraceptive use patterns in four European countries: evidence for selective prescribing of oral contraceptives containing third generation progestogens, *Eur J Contracept Reprod Health Care* 1:39, 1996.
186. **Lewis MA, Heinemann LAJ, MacRae KD, Bruppacher R, Spitzer WO**, The increased risk of venous thromboembolism and the use of third generation progestagens: role of bias in observational research, *Contraception* 54:5, 1996.
187. **Sheldon T**, Dutch GPs warned against new contraceptive pill, *Br Med J* 324:869, 2002.
188. **Pearce HM, Layton DW, Wilton LV, Shakir SA**, Deep vein thrombosis and pulmonary embolism reported in the Prescription Event Monitoring Study of Yasmin, *Br J Clin Pharmacol* 60:98, 2005.
189. **Dinger JC, Heinemann LA, Kühl-Habich D**, The safety of a drospirenone-containing oral contraceptive: final results from the European Active Surveillance Study on Oral Contraceptives based on 142,475 women-years of observation, *Contraception* 75:344, 2007.
190. **Seeger JD, Loughlin J, Eng PM, Clifford CR, Cutone J, Walker AM**, Risk of thromboembolism in women taking ethinylestradiol/drospirenone and other oral contraceptives, *Obstet Gynecol* 110:587, 2007.
191. **Lidegaard Ø, Lokkegaard E, Svendsen AL, Agger C**, Hormonal contraception and risk of venous thromboembolism: national follow-up study, *Br Med J* 339:b2890, 2009. doi:10.1136/bmj.b2890.
192. **van Hylckama Vlieg A, Helmerhorst FM, Vandenbroucke JP, Doggen CJM, Rosendaal FR**, The venous thrombotic risk of oral contraceptives, effects of oestrogen dose and progestogen type: results of the MEGA case-control study, *Br Med J* 339, 2009.
193. **Dinger JC, Bardenheuer K, Assmann A**, International active surveillance study of women taking oral contraceptives (INAS-OC study), *BMC Med Res Methodol* 9:77, 2009.
194. **Dinger JC, Bardenheuer K, Heinemann K**, Cardiovascular and general safety of a 24-day regimen of drospirenone-containing combined oral contraceptives: final results from the International Active Surveillance Study of Women Taking Oral Contraceptives, *Contraception* 89:253, 2014.
195. **Heinemann LA, Dinger JC**, Range of published estimates of venous thromboembolism incidence in young women, *Contraception* 75:328, 2007.
196. **Pomp ER, le Cessie S, Rosendaal FR, Doggen CJ**, Risk of venous thrombosis: obesity and its joint effect with oral contraceptive use and prothrombotic mutations, *Br J Haematol* 139:289, 2007.
197. **Pomp ER, Rosendaal FR, Doggen CJ**, Smoking increases the risk of venous thrombosis and acts synergistically with oral contraceptive use, *Am J Hematol* 83:97, 2008.
198. **van den Heuvel MW, van Bragt AJ, Ainabawy AK, Kaptein MC**, Comparison of ethinylestradiol

pharmacokinetics in three hormonal contraceptive formulations: the vaginal ring, the transdermal patch and an oral contraceptive, *Contraception* 72:168, 2005.

199. **Jick SS, Kaye JA, Russmann S, Jick H**, Risk of nonfatal venous thromboembolism in women using a contraceptive transdermal patch and oral contraceptives containing norgestimate and 35 mg of ethinyl estradiol, *Contraception* 73:223, 2006.
200. **Jick S, Kaye JA, Li L, Jick H**, Further results on the risk of nonfatal venous thromboembolism in users of the contraceptive transdermal patch compared to users of oral contraceptives containing norgestimate and 35 mg of ethinyl estradiol, *Contraception* 76:4, 2007.
201. **Cole JA, Norman H, Doherty M, Walker AM**, Venous thromboembolism, myocardial infarction, and stroke among transdermal contraceptive users, *Obstet Gynecol* 109:339, 2007.
202. **Jick SS, Hagberg KW, Hernandez RK, Kaye JA**, Postmarketing study of ORTHO EVRA and levonorgestrel oral contraceptives containing hormonal contraceptives with 30 mcg of ethinyl estradiol in relation to non-fatal venous thromboembolism, *Contraception* 81:16, 2010.
203. **Vensson PJ, Dahlbäck B**, Resistance to activated protein C as a basis for venous thrombosis, *N Engl J Med* 330:517, 1994.
204. **Hellgren M, Svensson PJ, Dahlbäck B**, Resistance to activated protein C as a basis for venous thromboembolism associated with pregnancy and oral contraceptives, *Am J Obstet Gynecol* 173:210, 1995.
205. **Vandenbroucke JP, Koster T, Briët E, Reitsma PH, Bertina RM, Rosendaal FR**, Increased risk of venous thrombosis in oral-contraceptive users who are carriers of factor V Leiden mutation, *Lancet* 344:1453, 1994.
206. **Spannagl M, Heinemann AJ, Schramm W**, Are factor V Leiden carriers who use oral contraceptives at extreme risk for venous thromboembolism?, *Eur J Contracept Reprod Health Care* 5:105, 2000.
207. **Bloemenkamp KW, Rosendaal FR, Helmerhorst FM, Vandenbroucke JP**, Higher risk of venous thrombosis during early use of oral contraceptives in women with inherited clotting defects, *Arch Intern Med* 160:49, 2000.
208. **Ridker PM, Miletich JP, Hennekens CH, Buring JE**, Ethnic distribution of factor V Leiden in 4047 men and women: implications for venous thromboembolism screening, *JAMA* 277:1305, 1997.
209. **Winkler UH**, Blood coagulation and oral contraceptives. A critical review, *Contraception* 57:203, 1998.
210. **Reich LM, Bower M, Key NS**, Role of the geneticist in testing and counseling for inherited thrombophilia, *Genet Med* 5:133, 2003.
211. **Lidegaard Ø, Kreiner S**, Cerebral thrombosis and oral contraceptives. A case-control study, *Contraception* 57:303, 1998.
212. **Lidegaard Ø, Edström B**, Oral contraceptives and myocardial infarction. A case-control study (abstract), *Eur J Contracept Reprod Health Care* 1(Suppl):72, 1996.
213. **Sidney S, Petitti DB, Quesenberry CP, Klatsky AL, Ziel HK, Wolf S**, Myocardial infarction in users of low-dose oral contraceptives, *Obstet Gynecol* 88:939, 1996.
214. **Lewis MA, Heinemann LAJ, Spitzer WO, MacRae KD, Bruppacher R; for the Transnational Research Group on Oral Contraceptives and the Health of Young Women**, The use of oral contraceptives and the occurrence of acute myocardial infarction in young women. Results from the Transnational Study on Oral Contraceptives and the Health of Young Women, *Contraception* 56: 129, 1997.
215. **Lewis MA, Spitzer WO, Heinemann LAJ, MacRae KD, Bruppacher R**, Lowered risk of dying of heart attack with third generation pill may offset risk of dying of thromboembolism, *Br Med J* 315:679, 1997.
216. **Dunn N, Thorogood M, Garagher B, de Caestecker L, MacDonald TM, McCollum C, Thomas S, Mann R**, Oral contraceptives and myocardial infarction: results of the MICA case-control study, *Br Med J* 318:1579, 1999.
217. **Rosenberg L, Palmer JR, Rao RS, Shapiro S**, Low-dose contraceptive use and the risk of myocardial infarction, *Arch Intern Med* 161:1065, 2001.
218. **WHO Collaborative Study of Cardiovascular Disease and Steroid Hormone Contraception**, Acute myocardial infarction and combined oral contraceptives: results of an international multicentre case-control study, *Lancet* 349:1202, 1997.



219. **Tanis BC, van den Bosch MA, Kemmeren JM, Cats VM, Helmerhorst FM, Algra A, van der Graaf Y, Rosendaal FR**, Oral contraceptives and the risk of myocardial infarction, *N Engl J Med* 345:1787, 2001.
220. **Margolis KL, Adami H-O, Luo J, Ye W, Weiderpass E**, A prospective study of oral contraceptive use and risk of myocardial infarction among Swedish women, *Fertil Steril* 88:310, 2007.
221. **Stampfer MJ, Willett WC, Colditz GA, Speizer FE, Hennekens CH**, A prospective study of past use of oral contraceptive agents and risk of cardiovascular diseases, *N Engl J Med* 319:1313, 1988.
222. **Mant J, Painter R, Vessey M**, Risk of myocardial infarction, angina and stroke in users of oral contraceptives: an updated analysis of a cohort study, *Br J Obstet Gynaecol* 105:890, 1998.
223. **Salonen JT**, Oral contraceptives, smoking and risk of myocardial infarction in young women: a longitudinal population study in eastern Finland, *Acta Med Scand* 212:141, 1982.
224. **Jick SS, Jick H**, The contraceptive patch in relation to ischemic stroke and acute myocardial infarction, *Pharmacotherapy* 27:218, 2007.
225. **Petitti DB, Sidney S, Quesenberry CP Jr, Bernstein A**, Incidence of stroke and myocardial infarction in women of reproductive age, *Stroke* 28:280, 1997.
226. **Jick H, Porter J, Rothman KJ**, Oral contraceptives and nonfatal stroke in healthy young women, *Ann Intern Med* 89:58, 1978.
227. **Vessey MP, Lawless M, Yeates D**, Oral contraceptives and stroke: findings in a large prospective study, *Br Med J* 289:530, 1984.
228. **Hannaford PC, Croft PR, Kay CR**, Oral contraception and stroke: evidence from the Royal College of General Practitioners' Oral Contraception Study, *Stroke* 25:935, 1994.
229. **Petitti DB, Sidney S, Bernstein A, Wolf S, Quesenberry C, Ziel HK**, Stroke in users of low-dose oral contraceptives, *N Engl J Med* 335:8, 1996.
230. **Heinemann LAJ, Lewis MA, Spitzer WO, Thorogood M, Guggenmoos-Holzmann I, Bruppacher R; the Transnational Research Group on Oral Contraceptives and the Health of Young Women**, Thromboembolic stroke in young women. A European case-control study on oral contraceptives, *Contraception* 57:29, 1998.
231. **Kemmeren JM, Tanis BC, van den Bosch MA, Bollen EL, Helmerhorst FM, van der Graaf Y, Rosendaal FR, Algra A**, Risk of arterial thrombosis in relation to oral contraceptives (RATIO) study: oral contraceptives and the risk of ischemic stroke, *Stroke* 33:1202, 2002.
232. **Schwartz SM, Siscovick DS, Longstreth WT Jr, Psaty BM, Beverly RK, Raghunathan TE, Lin D, Koepsell TD**, Use of low-dose oral contraceptives and stroke in young women, *Ann Intern Med* 127:596, 1997.
233. **Schwartz SM, Petitti DB, Siscovick DS, Longstreth NT Jr, Sidney S, Raghunathan TE, Quesenberry CP Jr, Kelaghan J**, Stroke and use of low-dose oral contraceptives in young women: a pooled analysis of two US studies, *Stroke* 29:2277, 1998.
234. **WHO Collaborative Study of Cardiovascular Disease and Steroid Hormone Contraception**, Ischaemic stroke and combined oral contraceptives: results of an international, multicentre case-control study, *Lancet* 348:498, 1996.
235. **WHO Collaborative Study of Cardiovascular Disease and Steroid Hormone Contraception**, Haemorrhagic stroke, overall stroke risk, and combined oral contraceptives: results of an international, multicentre, case-control study, *Lancet* 348:505, 1996.
236. **Lidegaard Ø, Kreiner S**, Contraceptives and cerebral thrombosis: a five-year national case-control study, *Contraception* 65:197, 2002.
237. **Yang L, Kuper H, Sandin S, Margolis KL, Chen Z, Adami HO, Weiderpass E**, Reproductive history, oral contraceptive use, and the risk of ischemic and hemorrhagic stroke in a cohort study of middle-aged Swedish women, *Stroke* 40:1050, 2009.
238. **Sidney S, Cooper WO**, Recent combined hormonal contraceptives and the risk of thromboembolism and other cardiovascular events in new users, *Contraception* 87:505, 2013.
239. **Barrett DH, Anda RF, Escobedo LG, Croft JB, Williamson DF, Marks JS**, Trends in oral contraceptive use and cigarette smoking, *Arch Fam Med* 3: 438, 1994.

240. **Juster HR, Loomis BR, Hinman TM, Farrelly MC, Hyland A, Bauer UE, Birkhead GS**, Declines in hospital admissions for acute myocardial infarction in New York state after implementation of a comprehensive smoking ban, *Am J Public Health* 97:2035, 2007.
241. **Seo DC, Torabi MR**, Reduced admissions for acute myocardial infarction associated with a public smoking ban: matched controlled study, *J Drug Educ* 37: 217, 2007.
242. **Wahl P, Walden C, Knopp R, Hoover J, Wallace R, Heiss R, Refkind B**, Effect of estrogen/progestin potency on lipid/lipoprotein cholesterol, *N Engl J Med* 308:862, 1983.
243. **Burkman RT, Robinson JC, Kruszon-Moran D, Kimball AW, Kwiterovich P, Burford RG**, Lipid and lipoprotein changes associated with oral contraceptive use: a randomized clinical trial, *Obstet Gynecol* 71:33, 1988.
244. **Patsch W, Brown SA, Grotto AM Jr, Young RL**, The effect of triphasic oral contraceptives on plasma lipids and lipoproteins, *Am J Obstet Gynecol* 161: 1396, 1989.
245. **Gevers Leuven JA, Dersjant-Roorda MC, Helmerhorst FM, de Boer R, Neymeyer-Leloux A, Havekes L**, Estrogenic effect of gestodene-desogestrel-containing oral contraceptives on lipoprotein metabolism, *Am J Obstet Gynecol* 163:358, 1990.
246. **Kloosterboer HJ, Rekers H**, Effects of three combined oral contraceptive preparations containing desogestrel plus ethinyl estradiol on lipid metabolism in comparison with two levonorgestrel preparations, *Am J Obstet Gynecol* 163: 370, 1990.
247. **Notelovitz M, Feldmand EB, Gillespy M, Gudat J**, Lipid and lipoprotein changes in women taking low-dose, triphasic oral contraceptives: a controlled, comparative, 12-month clinical trial, *Am J Obstet Gynecol* 160:1269, 1989.
248. **Young RL, DeConte A**, Effects of low-dose monophasic levonorgestrel with ethinyl estradiol preparation on serum lipid levels: a twenty-four-month clinical trial, *Am J Obstet Gynecol* 181:S59, 1999.
249. **Sibai BM, Odlind V, Meador ML, Shangold GA, Fisher AC, Creasy GW**, A comparative and pooled analysis of the safety and tolerability of the contraceptive patch (Ortho Evra™/Evra™), *Fertil Steril* 77(Suppl 2):S19, 2002.
250. **Adams MR, Clarkson TB, Koritnik DR, Nash HA**, Contraceptive steroids and coronary artery atherosclerosis in cynomolgus macaques, *Fertil Steril* 47: 1010, 1987.
251. **Clarkson TB, Adams MR, Kaplan JR, Shively CA, Koritnik DR**, From menarche to menopause: coronary artery atherosclerosis and protection in cynomolgus monkeys, *Am J Obstet Gynecol* 160:1280, 1989.
252. **Clarkson TB, Shively CA, Morgan TM, Koritnik DR, Adams MR, Kaplan JR**, Oral contraceptives and coronary artery atherosclerosis of cynomolgus monkeys, *Obstet Gynecol* 75:217, 1990.
253. **Kushwaha R, Hazzard W**, Exogenous estrogens attenuate dietary hypercholesterolemia and atherosclerosis in the rabbit, *Metabolism* 30:57, 1981.
254. **Hough JL, Zilversmit DB**, Effect of 17 beta estradiol on aortic cholesterol content and metabolism in cholesterol-fed rabbits, *Arteriosclerosis* 6:57, 1986.
255. **Henriksson P, Stamberger M, Eriksson M, Rudling M, Diczfalusy U, Berglund L, Angelin B**, Oestrogen-induced changes in lipoprotein metabolism: role in prevention of atherosclerosis in the cholesterol-fed rabbit, *Eur J Clin Invest* 19:395, 1989.
256. **Engel JH, Engel E, Lichtlen PR**, Coronary atherosclerosis and myocardial infarction in young women—role of oral contraceptives, *Eur Heart J* 4:1, 1983.
257. **Jugdutt BI, Stevens GF, Zacks DJ, Lee SJK, Taylor RF**, Myocardial infarction, oral contraception, cigarette smoking, and coronary artery spasm in young women, *Am Heart J* 106:757, 1983.
258. **Kovacs L, Bartfai G, Apro G, Annus J, Bulpitt C, Belsey E, Pinol A**, The effect of the contraceptive pill on blood pressure: a randomized controlled trial of three progestogen-oestrogen combinations in Szeged, Hungary, *Contraception* 33:69, 1986.
259. **Giribela CR, Consolim-Colombo FM, Nisenbaum MG, Moraes TL, Giribela AH, Baracat EC, Melo NR**, Effects of a combined oral contraceptive containing 20 mcg of ethinylestradiol and 3 mg of drospirenone on the blood pressure, renin-angiotensin-aldosterone system, insulin resistance, and androgenic profile of healthy young women. *Gynecol Endocrinol* 31(11), 912–915, 2015.

260. **Nisenbaum MG, de Melo NR, Giribela CR, de Morais TL, Guerra GM, de Angelis K, Mostarda C, Baracat EC, Consolim-Colombo FM**, Effects of a contraceptive containing drospirenone and ethinyl estradiol on blood pressure and autonomic tone: a prospective controlled clinical trial, *Eur J Obstet Gynecol Reprod Biol* 175:62–66, 2014.
261. **Nichols M, Robinson G, Bounds W, Newman B, Guillebaud J**, Effect of four combined oral contraceptives on blood pressure in the pill-free interval, *Contraception* 47:367, 1993.
262. **Qifang S, Deliang L, Ziurong J, Haifang L, Zhongshu Z**, Blood pressure changes and hormonal contraceptives, *Contraception* 50:131, 1994.
263. **Darney P**, Safety and efficacy of a triphasic oral contraceptive containing desogestrel: results of three multicenter trials, *Contraception* 48:323, 1993.
264. **Farahmand M, Ramezani Tehrani F, Rostami Dovom M, Hashemi S, Azizi F**, The impact of oral contraceptives on cardiometabolic parameters, *J Endocrinol Invest* 39:277, 2016.
265. **Chasan-Taber L, Willett WC, Manson JE, Spiegelman D, Hunter DJ, Curhan G, Colditz GA, Stampfer MJ**, Prospective study of oral contraceptives and hypertension among women in the United States, *Circulation* 94:483, 1996.
266. **Brady WA, Kritz-Silverstein D, Barrett-Connor E, Morales AJ**, Prior oral contraceptive use is associated with higher blood pressure in older women, *J Womens Health* 7:221, 1998.
267. **Pritchard JA, Pritchard SA**, Blood pressure response to estrogen-progestin oral contraceptives after pregnancy-induced hypertension, *Am J Obstet Gynecol* 129:733, 1977.
268. **Braken MB, Srisuphan W**, Oral contraception as a risk factor for preeclampsia, *Am J Obstet Gynecol* 142:191, 1982.
269. **Gratacos E, Torres P, Cararach V, Quinto L, Alonso PL, Fortuny A**, Does the use of contraception reduce the risk of pregnancy-induced hypertension?, *Hum Reprod* 11:2138, 1996.
270. **Thadhani R, Stampfer MJ, Chasan-Taber L, Willett WC, Curhan GC**, A prospective study of pregravid oral contraceptive use and risk of hypertensive disorders of pregnancy, *Contraception* 60:145, 1999.
271. **Lubianca JN, Faccin CS, Fuchs FD**, Oral contraceptives: a risk factor for uncontrolled blood pressure among hypertensive women, *Contraception* 67:19, 2003.
272. **Cosmi B, Legnani C, Bernardi F, Coccheri S, Palareti G**, Role of family history in identifying women with thrombophilia and higher risk of venous thromboembolism during oral contraception, *Arch Intern Med* 163:1105, 2003.
273. **Baglin T, Luddington R, Brown K, Baglin C**, Incidence of recurrent venous thromboembolism in relation to clinical and thrombophilic risk factors: prospective cohort study, *Lancet* 362:523, 2003.
274. **de Bruijn SFTM, Stam J, Koopman MMW, Vandenbroucke JP; for the Cerebral Venous Sinus Thrombosis Study Group**, Case-control study of risk of cerebral sinus thrombosis in oral contraceptive users who are carriers of hereditary prothrombotic conditions, *Br Med J* 316:589, 1998.
275. **Jick SS, Jick H**, Cerebral venous sinus thrombosis in users of four hormonal contraceptives: levonorgestrel-containing oral contraceptives, norgestimate-containing oral contraceptives, desogestrel-containing oral contraceptives and the contraceptive patch, *Contraception* 74:290, 2006.
276. **Pabinger I, Schneider B; the GTH Study Group**, Thrombotic risk of women with hereditary antithrombin III, protein C, and protein S deficiency taking oral contraceptive medication, *Thromb Haemost* 5:548, 1994.
277. **Godsland IF, Crook D, Simpson R, Proudler T, Gelton C, Lees B, Anyaoku V, Devenport M, Wynn V**, The effects of different formulations of oral contraceptive agents on lipid and carbohydrate metabolism, *N Engl J Med* 323: 1375, 1990.
278. **van der Vange N, Kloosterboer HJ, Haspels AA**, Effect of seven low-dose combined oral contraceptive preparations on carbohydrate metabolism, *Am J Obstet Gynecol* 156:918, 1987.
279. **Bowes WA, Katta LR, Droegemueller W, Bright TG**, Triphasic randomized clinical trial: comparison of effects on carbohydrate metabolism, *Am J Obstet Gynecol* 161:1402, 1989.
280. **Gasparid UJ, Lefebvre PJ**, Clinical aspects of the relationship between oral contraceptives, abnormalities in carbohydrate metabolism, and the development of cardiovascular disease, *Am J Obstet Gynecol* 163:334, 1990.
281. **Troisi RJ, Cowie CC, Harris MI**, Oral contraceptive use and glucose metabolism in a national sample of

- women in the United States, *Am J Obstet Gynecol* 183:389, 2000.
282. **Hannaford PC, Kay CR**, Oral contraceptives and diabetes mellitus, *Br Med J* 299:315, 1989.
  283. **Rimm EB, Manson JE, Stampfer MJ, Colditz GA, Willett WC, Rosner B, Hennekens CH, Speizer FE**, Oral contraceptive use and the risk of type 2 (non-insulin-dependent) diabetes mellitus in a large prospective study of women, *Diabetologia* 35:967, 1992.
  284. **Duffy TJ, Ray R**, Oral contraceptive use: prospective follow-up of women with suspected glucose intolerance, *Contraception* 30:197, 1984.
  285. **Chasan-Taber L, Colditz GA, Willett WC, Stampfer MJ, Hunter DJ, Colditz GA, Spiegelman D, Manson JE**, A prospective study of oral contraceptives and NIDDM among U.S. women, *Diabetes Care* 20:330, 1997.
  286. **Kjos SL, Shoupe D, Douyan S, Friedman RL, Bernstein GS, Mestman JH, Mishell DR Jr**, Effect of low-dose oral contraceptives on carbohydrate and lipid metabolism in women with recent gestational diabetes: results of a controlled, randomized, prospective study, *Am J Obstet Gynecol* 163:1822, 1990.
  287. **Kjos SL, Peters RK, Xiang A, Thomas D, Schaefer U, Buchanan TA**, Contraception and the risk of type 2 diabetes in Latino women with prior gestational diabetes, *JAMA* 280:533, 1998.
  288. **Skouby SO, Malsted-Pedersen L, Kuhl C, Bennet P**, Oral contraceptives in diabetic women: metabolic effects of compounds with different estrogen/progestogen profiles, *Fertil Steril* 46:858, 1986.
  289. **Garg SK, Chase HP, Marshall G, Hoops SL, Holmes DL, Jackson WE**, Oral contraceptives and renal and retinal complications in young women with insulin-dependent diabetes mellitus, *JAMA* 271:1099, 1994.
  290. **Petersen KR, Skouby SO, Sidelmann J, Mølsted-Petersen L, Jespersen J**, Effects of contraceptive steroids on cardiovascular risk factors in women with insulin-dependent diabetes mellitus, *Am J Obstet Gynecol* 171:400, 1994.
  291. **Klein BE, Klein R, Moss SE**, Mortality and hormone-related exposures in women with diabetes, *Diabetes Care* 22:248, 1999.
  292. **Grigoryan OR, Grodnitskaya EE, Andreeva EN, Chebotnikova TV, Melnichenko GA**, Use of the NuvaRing hormone-releasing system in late reproductive-age women with type 1 diabetes mellitus, *Gynecol Endocrinol* 24:99, 2008.
  293. **Hannaford PC, Kay CR, Vessey MP, Painter R, Mant J**, Combined oral contraceptives and liver disease, *Contraception* 55:145, 1997.
  294. **Royal College of General Practitioners' Oral Contraception Study**, Oral contraceptives and gallbladder disease, *Lancet* ii:957, 1982.
  295. **Bennion LJ, Ginsberg RL, Garnick MB, Bennett PH**, Effects of oral contraceptives on the gallbladder bile of normal women, *N Engl J Med* 294:189, 1976.
  296. **Grodstein F, Colditz GA, Hunter DJ, Manson JE, Willett WC, Stampfer MJ**, A prospective study of symptomatic gallstones in women: relation with oral contraceptives and other risk factors, *Obstet Gynecol* 84:207, 1994.
  297. **La Vecchia C, Negri E, D'Avanzo B, Parazzini F, Genitle A, Franceschi S**, Oral contraceptives and noncontraceptive oestrogens in the risk of gallstone disease requiring surgery, *J Epidemiol Community Health* 46:234, 1992.
  298. **Vessey M, Painter R**, Oral contraceptive use and benign gallbladder disease; revisited, *Contraception* 50:167, 1994.
  299. **Cherqui D, Rahmouni A, Charlotte F, Boulahdour H, Metreau JM, Meignan M, Fagniez PL, Zafrani ES, Mathieu D, Dhumeaux C**, Management of focal nodular hyperplasia and hepatocellular adenoma in young women: a series of 41 patients with clinical radiological and pathological correlations, *Hepatology* 22:1674, 1995.
  300. **Côté C**, Regression of focal nodular hyperplasia of the liver after oral contraceptive discontinuation, *Clin Nucl Med* 9:587, 1997.
  301. **Heinemann LA, Weimann A, Gerken G, Thiel C, Schlaud M, Do Minh T**, Modern oral contraceptive use and benign liver tumors: the German Benign Liver Tumor Case-Control Study, *Eur J Contracept Reprod Health Care* 3:194, 1998.

302. **Scalori A, Tavani A, Gallus S, La Vecchia C, Colombo M**, Oral contraceptives and the risk of focal nodular hyperplasia of the liver: a case-control study, *Am J Obstet Gynecol* 186:195, 2002.
303. **Lucky AW, Henderson TA, Olson WH, Robisch DM, Lebwohl M, Swinyer LJ**, Effectiveness of norgestimate and ethinyl estradiol in treating moderate acne vulgaris, *J Am Acad Dermatol* 37:746, 1997.
304. **Redmond GP, Olson WH, Lippman JS, Kafriksen ME, Jones TM, Jorizzo JL**, Norgestimate and ethinyl estradiol in the treatment of acne vulgaris: a randomized, placebo-controlled trial, *Obstet Gynecol* 89:615, 1997.
305. **Redmond G, Godwin AJ, Olson W, Lippman JS**, Use of placebo controls in an oral contraceptive trial: methodological issues and adverse event incidence, *Contraception* 60:81, 1999.
306. **Carpenter S, Neinstein LS**, Weight gain in adolescent and young adult oral contraceptive users, *J Adolesc Health Care* 7:342, 1986.
307. **Reubinoff BE, Wurtman J, Rojansky N, Adler D, Stein P, Schenker JG, Brzezinski A**, Effects of hormone replacement therapy on weight, body composition, fat distribution, and food intake in early postmenopausal women: a prospective study, *Fertil Steril* 64:963, 1995.
308. **Moore LL, Valuck R, McDougall C, Fink W**, A comparative study of one-year weight gain among users of medroxyprogesterone acetate, levonorgestrel implants, and oral contraceptives, *Contraception* 52:215, 1995.
309. **Rosenberg M**, Weight change with oral contraceptive use and during the menstrual cycle. Results of daily measurements. *Contraception* 58:345, 1998.
310. **Risser WL, Geftter L, Barratt MS, Risser JM**, Weight change in adolescents who used hormonal contraception, *J Adolesc Health* 24:433, 1999.
311. **Gupta S**, Weight gain on the combined pill—is it real?, *Hum Reprod Update* 6:427, 2000.
312. **Thiboutot D, Archer DF, Lemay A, Washenik K, Roberts J, Harrison DD**, A randomized, controlled trial of a low-dose contraceptive containing 20 mg of ethinyl estradiol and 100 mg of levonorgestrel for acne treatment, *Fertil Steril* 76:461, 2001.
313. **Coney P, Washenik K, Langley RGB, DiGiovanna JJ, Harrison DD**, Weight change and adverse event incidence with a low-dose oral contraceptive: two randomized, placebo-controlled trials, *Contraception* 63:297, 2001.
314. **Vessey MP, Villard-Mackintosh L, Painter R**, Oral contraceptives and pregnancy in relation to peptic ulcer, *Contraception* 46:349, 1992.
315. **Lashner BA, Kane SV, Hanauer SB**, Lack of association between oral contraceptive use and ulcerative colitis, *Gastroenterology* 99:1032, 1990.
316. **Torok HM**, A comprehensive review of the long-term and short-term treatment of melasma with a triple combination cream, *Am J Clin Dermatol* 7:223, 2006.
317. **Milman N, Kirchhoff M, Jorgensen T**, Iron status markers, serum ferritin and hemoglobin in 1359 Danish women in relation to menstruation, hormonal contraception, parity, and postmenopausal hormone treatment, *Ann Hematol* 65:96, 1992.
318. **Galan P, Yoon HC, Preziosi P, Viteri P, Fieux B, Briancon S, Malvy D, Roussel AM, Favier A, Hercberg S**, Determining factors in the iron status of adult women in the SU.VI.MAX study, *Eur J Clin Nutr* 52:383, 1998.
319. **Task Force for Epidemiological Research on Reproductive Health, United Nations Development Programme/United Nations Population Fund/World Health Organization/World Bank Special Programme of Research, Development and Research Training in Human Reproduction**, Effects of contraceptives on hemoglobin and ferritin, *Contraception* 58:261, 1998.
320. **Mooij PN, Thomas CMG, Doesburg WH, Eskes TK**, Multivitamin supplementation in oral contraceptive users, *Contraception* 44:277, 1991.
321. **Skovlund CW, Morch LS, Kessing LV, Lidegaard O**, Association of hormonal contraception with depression, *JAMA Psychiat* 73:1154, 2016.
322. **Skovlund CW, Morch LS, Kessing LV, Lange T, Lidegaard O**, Association of hormonal contraception with suicide attempts and suicides, *Am J Psychiatry* 175:336, 2018.
323. **Keyes KM, Cheslack-Postava K, Westhoff C, Heim CM, Haloossim M, Walsh K, Koenen K**, Association of hormonal contraceptive use with reduced levels of depressive symptoms: a national study of

sexually active women in the United States, *Am J Epidemiol* 178:1378, 2013.

324. **Toffol E, Heikinheimo O, Koponen P, Luoto R, Partonen T**, Hormonal contraception and mental health: results of a population-based study, *Hum Reprod* 26:3085, 2011.
325. **Worly BL, Gur TL, Schaffir J**, The relationship between progestin hormonal contraception and depression: a systemic review, *Contraception* 97:478, 2018.
326. **Pagano HP, Zapata LB, Berry-Bibee EN, Nanda K, Curtis KM**, Safety of hormonal contraception and intrauterine devices among women with depressive and bipolar disorders: a systematic review, *Contraception* 94:641, 2016.
327. **Schaffir J, Worly BL, Gur TL**, Combined hormonal contraception and its effects on mood: a critical review, *Eur J Contracept Reprod Health Care* 21:347, 2016.
328. **Lundin C, Danielsson KG, Bixo M, Moby L, Bengtsdotter H**, et al., Combined oral contraceptive use is associated with both improvement and worsening of mood in the different phases of the treatment cycle—a double blind, placebo-controlled randomized trial, *Psychoneuroendocrinology* 76:135, 2017.
329. **Davis AR, Castaño PM**, Oral contraceptives and libido in women, *Annu Rev Sex Res* 15:297, 2004.
330. **Oranratanaphan S, Taneepanichskul S**, A double blind randomized control trial, comparing effect of drospirenone and gestodene to sexual desire and libido, *J Med Assoc Thai* 89(Suppl 4):S17, 2006.
331. **Greco T, Graham CA, Bancroft J, Tanner A, Doll HA**, The effects of oral contraceptives on androgen levels and their relevance to premenstrual mood and sexual interest: a comparison of two triphasic formulations containing norgestimate and either 35 or 25 mg of ethinyl estradiol, *Contraception* 76:8, 2007.
332. **Wendler J, Siegert C, Schelhorn P, Klinger G, Gurr S, Kaufmann J, Aydinlik S, Braunschweig T**, The influence of Microgynon® and Diane-35®, two sub-fifty ovulation inhibitors, on voice function in women, *Contraception* 52:343, 1995.
333. **The Cancer and Steroid Hormone Study of the CDC and NICHD**, Combination oral contraceptive use and the risk of endometrial cancer, *JAMA* 257:796, 1987.
334. **Schlesselman JJ**, Oral contraceptives and neoplasia of the uterine corpus, *Contraception* 43:557, 1991.
335. **Vessey MP, Painte R**, Endometrial and ovarian cancer and oral contraceptives—findings in a large cohort study, *Br J Cancer* 71:1340, 1995.
336. **Schlesselman JJ**, Risk of endometrial cancer in relation to use of combined oral contraceptives. A practitioner's guide to meta-analysis, *Hum Reprod* 12: 1851, 1997.
337. **Salazar-Martinez E, Lazcano-Ponce EC, Gonzalez Lira-Lira G, Escudero-De los Rios P, Salmeron-Castro J, Hernandez-Avila M**, Reproductive factors of ovarian and endometrial cancer risk in a high fertility population in Mexico, *Cancer Res* 59:3658, 1999.
338. **Weiderpass E, Adami HO, Baron JA, Magnusson C, Lindgren A, Persson I**, Use of oral contraceptives and endometrial cancer risk (Sweden), *Cancer Causes Control* 10:277, 1999.
339. **Jick SS, Walker AM, Jick H**, Oral contraceptives and endometrial cancer, *Obstet Gynecol* 82:931, 1993.
340. **Sherman ME, Sturgeon S, Brinton LA, Potischman N, Kurman RJ, Berman ML, Mortel R, Twiggs LB, Barrett RJ, Wilbanks GD**, Risk factors and hormone levels in patients with serous and endometrioid uterine carcinomas, *Mod Pathol* 10:963, 1997.
341. **Mant JWF, Vessey MP**, Ovarian and endometrial cancers, *Cancer Surv* 19: 287, 1994.
342. **Adami HO, Bergstrom R, Persson I, Sparen P**, The incidence of ovarian cancer in Sweden, 1960–1984, *Am J Epidemiol* 132:446, 1990.
343. **Silva IS, Swerdlow AJ**, Recent trends in incidence of and mortality from breast, ovarian and endometrial cancer in England and Wales and their relation to changing fertility and oral contraceptive use, *Br J Cancer* 72:485, 1995.
344. **Oriel KA, Hartenbach EM, Remington PL**, Trends in United States ovarian cancer mortality, 1979–1995, *Obstet Gynecol* 93:30, 1999.
345. **Lurie G, Thompson P, McDuffie KE, Carney ME, Terada KY, Goodman MT**, Association of estrogen and progestin potency of oral contraceptives with ovarian carcinoma risk, *Obstet Gynecol* 109:597, 2007.
346. **The Cancer and Steroid Hormone Study of the CDC and NICHD**, The reduction in risk of ovarian cancer associated with oral-contraceptive use, *N Engl J Med* 316:650, 1987.

347. **Hankinson SE, Colditz GA, Hunter DJ, Spencer TL, Rosner B, Stampfer MJ**, A quantitative assessment of oral contraceptive use and risk of ovarian cancer, *Obstet Gynecol* 80:708, 1992.
348. **Whittemore AS, Harris R, Itnyre J; the Collaborative Ovarian Cancer Group**, Characteristics relating to ovarian cancer risk: collaborative analysis of 12 US case-control studies. II: Invasive epithelial ovarian cancers in white women, *Am J Epidemiol* 136:1184, 1992.
349. **Wittenberg L, Cook LS, Rossing MA, Weiss NS**, Reproductive risk factors for mucinous and non-mucinous epithelial ovarian cancer, *Epidemiology* 10: 761, 1999.
350. **Ness RB, Grisso JA, Klapper J, Schlesselman JJ, Silberzweig S, Vergona R, Morgan M, Wheeler JE; the SHARE Study Group**, Risk of ovarian cancer in relation to estrogen and progestin dose and use characteristics of oral contraceptives, *Am J Epidemiol* 152:233, 2000.
351. **Royar J, Becher H, Chang-Claude J**, Low-dose oral contraceptives: protective effect on ovarian cancer risk, *Int J Cancer* 95:370, 2001.
352. **Collaborative Group on Epidemiological Studies of Ovarian Cancer, Beral V, Doll R, Hermon C, Peto R, Reeves G**, Ovarian cancer and oral contraceptives: collaborative reanalysis of data from 45 epidemiological studies including 23,257 women with ovarian cancer and 87,303 controls, *Lancet* 371:303, 2008.
353. **Tworoger SS, Fairfield KM, Colditz GA, Rosner BA, Hankinson SE**, Association of oral contraceptive use, other contraceptive methods, and infertility with ovarian cancer risk, *Am J Epidemiol* 166:894, 2007.
354. **Rosenberg L, Palmer JR, Zauber AG, Warshauer ME, Lewis JL Jr, Strom BL, Harlap S, Shapiro S**, A case-control study of oral contraceptive use and invasive epithelial ovarian cancer, *Am J Epidemiol* 139:654, 1994.
355. **Gross TP, Schlesselman JJ**, The estimated effect of oral contraceptive use on the cumulative risk of epithelial ovarian cancer, *Obstet Gynecol* 83:419, 1994.
356. **Walker GR, Schlesselman J, Ness RB**, Family history of cancer, oral contraceptive use, and ovarian cancer risk, *Am J Obstet Gynecol* 186:8, 2002.
357. **Narod SA, Risch H, Moslehi R, Dørum A, Neuhausen S, Olsson H, Provencher D, Radice P, Evans G, Bishop S, Brunet J-S, Ponder BAJ; for the Hereditary Ovarian Cancer Clinical Study Group**, Oral contraceptives and the risk of hereditary ovarian cancer, *N Engl J Med* 339:424, 1998.
358. **Whittemore AS, Balise RR, Pharoah PD, Dicioccio RA, Oakley-Girvan I, Ramus SJ, Daly M, Usinowicz MB, Garlinghouse-Jones K, Ponder BA, Buys SS, Senie RT, Andrulis IL, John EM, Hopper JL, Piver MS**, Oral contraceptive use and ovarian cancer risk among carriers of BRCA1 or BRCA2 mutations, *Br J Cancer* 91:1911, 2004.
359. **McLaughlin JR, Risch HA, Lubinski J, Moller P, Ghadirian P, Lynch H, Karlan B, Fishman D, Rosen B, Neuhausen SL, Offit K, Kauff N, Domchek S, Tung N, Friedman E, Foulkes W, Sun P, Narod SA; Hereditary Ovarian Cancer Clinical Study Group**, Reproductive risk factors for ovarian cancer in carriers of BRCA1 or BRCA2 mutations: a case-control study, *Lancet Oncol* 8:26, 2007.
360. **Brinton LA**, Oral contraceptives and cervical neoplasia, *Contraception* 43:581, 1991.
361. **Delgado-Rodriguez M, Sillero-Arenas M, Martin-Moreno JM, Galvez-Vargas R**, Oral contraceptives and cancer of the cervix uteri. A meta-analysis, *Acta Obstet Gynecol Scand* 71:368, 1992.
362. **Gram IT, Macaluso M, Stalsberg H**, Oral contraceptive use and the incidence of cervical intraepithelial neoplasia, *Am J Obstet Gynecol* 167:40, 1992.
363. **Irwin KL, Rosero-Bixby L, Oberle MW, Lee NC, Whatley AS, Fortney JA, Bonhomme MG**, Oral contraceptives and cervical cancer risk in Costa Rica: detection bias or causal association?, *JAMA* 259:59, 1988.
364. **Ye Z, Thomas DB, Ray RM; the WHO Collaborative Study of Neoplasia and Steroid Contraceptives**, Combined oral contraceptives and risk of cervical carcinoma in situ, *Int J Epidemiol* 24:19, 1995.
365. **Iversen L, Sivasubramaniam S, Lee AJ, Fielding S, Hannaford PC**, Lifetime cancer risk and combined oral contraceptives: the Royal College of General Practitioners' oral contraceptive study, *Am J Obstet Gynecol* 216:580, 2017.
366. **Ylitalo N, Sorensen P, Josefsson A, Frisch M, Sparen P, Ponten J, Gyllensten U, Melbye M, Adami HO**, Smoking and oral contraceptives as risk factors for cervical carcinoma in situ, *Int J Cancer* 81:357, 1999.

367. **Brinton LA, Reeves WC, Brenes MM, Herrero R, de Britton RC, Gaitan E, Tenorio F, Garcia M, Rawls WE**, Oral contraceptive use and risk of invasive cervical cancer, *Int J Epidemiol* 19:4, 1990.
368. **Ursin G, Peters RK, Hendeson BE, d'Ablaing G III, Monroe KR, Pike MC**, Oral contraceptive use and adenocarcinoma of cervix, *Lancet* 344:1390, 1994.
369. **Thomas DB, Ray RM; the World Health Organization Collaborative Study of Neoplasia and Steroid Contraceptives**, Oral contraceptives and invasive adenocarcinomas and adenosquamous carcinomas of the uterine cervix, *Am J Epidemiol* 144:281, 1996.
370. **Smith JS, Green J, de Gonzalez AB, Appleby P, Peto J, Plummer M, Franceschi S, Beral V**, Cervical cancer and use of hormonal contraceptives: a systematic review, *Lancet* 361:1159, 2003.
371. **Moreno V, Bosch FX, Muñoz N, Meijer CJLM, Shah KV, Walboomers JMM, Herrero R, Franceschi S; for the International Agency for Research on Cancer (IARC) Multicentric Cervical Cancer Study Group**, Effect of oral contraceptives on risk of cervical cancer in women with human papillomavirus infection: the IARC multicentric case-control study, *Lancet* 359:1085, 2002.
372. **International Collaboration of Epidemiological Studies of Cervical Cancer**, Cervical cancer and hormonal contraceptives: collaborative reanalysis of individual data for 16573 women with cervical cancer and 35509 women without cervical cancer from 24 epidemiological studies, *Lancet* 370:1609, 2007.
373. **Neuberger J, Forman D, Doll R, Williams R**, Oral contraceptives and hepatocellular carcinoma, *Br Med J* 292:1355, 1986.
374. **Palmer JR, Rosenberg L, Kaufman DW, Warshauer ME, Stolley P, Shapiro S**, Oral contraceptive use and liver cancer, *Am J Epidemiol* 130:878, 1989.
375. **WHO Collaborative Study of Neoplasia and Steroid Contraceptives**, Combined oral contraceptives and liver cancer, *Int J Cancer* 43:254, 1989.
376. **The Collaborative MILTS Project Team**, Oral contraceptives and liver cancer. Results of the Multicentre International Liver Tumor Study (MILTS), *Contraception* 56:275, 1997.
377. **Mant JW, Vessey MP**, Trends in mortality from primary liver cancer in England and Wales 1975–92: influence of oral contraceptives, *Br J Cancer* 72:800, 1995.
378. **Waetjen LE, Grimes DA**, Oral contraceptives and primary liver cancer: temporal trends in three countries, *Obstet Gynecol* 88:945, 1996.
379. **El-Serag HB, Mason AC**, Rising incidence of hepatocellular carcinoma in the United States, *N Engl J Med* 340:745, 1999.
380. **McPherson K, Neil A, Vessey MP**, Oral contraceptives and breast cancer, *Lancet* ii:414, 1983.
381. **La Vecchia C, Decarli A, Fasoli M, Franceschi S, Gentile A, Negri E, Parazzini F, Tognomi G**, Oral contraceptives and cancers of the breast and of the female genital tract. Interim results from a case-control study, *Br J Cancer* 54:311, 1986.
382. **Meirik O, Dami H, Christoffersen T, Lund E, Bergstrom R, Bergsjö P**, Oral contraceptive use and breast cancer in young women, *Lancet* ii:650, 1986.
383. **Kay CR, Hannaford PC**, Breast cancer and the pill — further report from the Royal College of General Practitioners' oral contraceptive study, *Br J Cancer* 58:675, 1988.
384. **Miller DR, Rosenberg L, Kaufman DW, Stolley P, Warshauer ME, Shapiro S**, Breast cancer before age 45 and oral contraceptive use: new findings, *Am J Epidemiol* 129:269, 1989.
385. **UK National Case-Control Study Group**, Oral contraceptive use and breast cancer risk in young women, *Lancet* i:973, 1989.
386. **WHO Collaborative Study of Neoplasia and Steroid Contraceptives**, Breast cancer and combined oral contraceptives: results from a multinational study, *Br J Cancer* 61:110, 1990.
387. **La Vecchia C, Negri E, Franceschi S, Talamini R, Amadori D, Filiberti R, Conti E, Montella M, Veronesi A, Parazzini F, Ferraroni M, Decarli A**, Oral contraceptives and breast cancer: a cooperative Italian study, *Int J Cancer* 60: 163, 1995.
388. **Del Pup L, Codacci-Pisanelli G, Peccatori F**, Breast cancer risk of hormonal contraception: Counselling considering new evidence, *Crit Rev Oncol Hematol* 137:123–130, 2019.
389. **Rosenberg L, Palmer JR, Rao RS, Zauber AG, Strom BL, Warshauer ME, Harlap S, Shapiro S**, Case-



- control study of oral contraceptive use and risk of breast cancer, *Am J Epidemiol* 143:25, 1996.
390. **Hennekens CH, Speizer FE, Lipnik RJ, Rosner B, Bain C, Belanger C, Stampfer MJ, Willett W, Peto R**, Case-control study of oral contraceptive use and breast cancer, *J Natl Cancer Inst* 72:39, 1984.
  391. **Rosenberg L, Miller DR, Kaufman DW, Helmrich SP, Stolley PD, Schoffenfeld D, Shapiro S**, Breast cancer and oral contraceptive use, *Am J Epidemiol* 119:167, 1984.
  392. **Stadel BV, Rubin GL, Webster LA, Schlesselman JJ, Wingo PA**, Oral contraceptives and breast cancer in young women, *Lancet* ii:970, 1985.
  393. **Mørch LS, Skovlund CW, Hannaford PC, Iversen L, Fielding S, Lidegaard Ø**, Contemporary hormonal contraception and the risk of breast cancer, *N Engl J Med* 377:2228, 2017.
  394. **Pike MC, Krailo MD, Henderson BE, Duke A, Roy S**, Breast cancer in young women and use of oral contraceptives: possible modifying effect of formulation and age at use, *Lancet* ii:926, 1983.
  395. **Wingo PA, Lee NC, Ory HW, Beral V, Peterson HB, Rhodes P**, Age-specific differences in the relationship between oral contraceptive use and breast cancer, *Obstet Gynecol* 78:161, 1991.
  396. **Ursin G, Aragaki CC, Paganini-Hill A, Siemiatycki J, Thompson WD, Haile RW**, Oral contraceptives and premenopausal bilateral breast cancer: a case-control study, *Epidemiology* 3:414, 1992.
  397. **Rookus MA, Leeuwen FE; for the Netherlands Oral Contraceptives and Breast Cancer Study Group**, Oral contraceptives and risk of breast cancer in women aged 20–54 years, *Lancet* 344:844, 1994.
  398. **White E, Malone KE, Weiss NS, Daling JR**, Breast cancer among young U.S. women in relation to oral contraceptive use, *J Natl Cancer Inst* 86:505, 1994.
  399. **Brinton LA, Daling JR, Liff JM, Schoenberg JB, Malone KE, Stanford JL, Coates RJ, Gammon MD, Hanson L, Hoover RN**, Oral contraceptives and breast cancer risk among younger women, *J Natl Cancer Inst* 87:827, 1995.
  400. **Collaborative Group on Hormonal Factors in Breast Cancer**, Breast cancer and hormonal contraceptives: collaborative reanalysis of individual data on 53,297 women with breast cancer and 100,239 women without breast cancer from 54 epidemiological studies, *Lancet* 347:1713, 1996.
  401. **Collaborative Group on Hormonal Factors in Breast Cancer**, Breast cancer and hormonal contraceptives: further results, *Contraception* 54:1S, 1996.
  402. **Kumle M, Weiderpass E, Braaten T, Persson I, Adami H-O, Lund E**, Use of oral contraceptives and breast cancer risk: the Norwegian-Swedish Women's Lifestyle and Health Cohort Study, *Cancer Epidemiol Biomarkers Prev* 11:1375, 2002.
  403. **Cancer and Steroid Hormone Study, CDC and NICHD**, Oral contraceptive use and the risk of breast cancer, *N Engl J Med* 315:405, 1986.
  404. **Schlesselman JJ, Stadel BV, Murray P, Shenghan L**, Breast cancer risk in relation to type of estrogen contained in oral contraceptives, *Contraception* 36: 595, 1987.
  405. **Stanford JL, Brinton LA, Hoover RN**, Oral contraceptives and breast cancer: results from an expanded case-control study, *Br J Cancer* 60:375, 1989.
  406. **Murray P, Schlesselman JJ, Stadel BV, Shenghan L**, Oral contraceptives and breast cancer risk in women with a family history of breast cancer, *Am J Obstet Gynecol* 73:977, 1989.
  407. **Schildkraut JM, Hulka BS, Wilkinson WE**, Oral contraceptives and breast cancer: a case-control study with hospital and community controls, *Obstet Gynecol* 76:395, 1990.
  408. **Lambe M, Hsieh C, Trichopoulos D, Ekbohm A, Pavia M, Adami H-O**, Transient increase in the risk of breast cancer after giving birth, *N Engl J Med* 331:5, 1994.
  409. **Guinee VF, Olsson H, Moller T, Hess KR, Taylor SH, Fahey T, Gladikov JV, van den Blink JW, Bonichon F, Dische S, et al.**, Effect of pregnancy on prognosis for young women with breast cancer, *Lancet* 343:1587, 1994.
  410. **Kroman N, Wohlfart J, Andersen KW, Mouriudsen HT, Westergaard U, Melbye M**, Time since childbirth and prognosis in primary breast cancer: population based study, *Br Med J* 315:851, 1997.
  411. **Narod S, Dube MP, Klijn J, Lubinski J, Lynch HT, Ghadirian P, Provencher D, et al.**, Oral contraceptives and the risk of breast cancer in BRCA1 and BRCA2 mutation carriers, *J Natl Cancer Inst* 94:1773, 2002.

412. **Haile RW, Thomas DC, McGuire V, Felberg A, John EM, Milne R, Hopper JL, Jenkins MA, Levine AJ, Daly MM, Buys SS, Senie RT, Andrulis IL, Knight JA, Godwin AK, Southey M, McCredie MR, Giles GG, Andrews L, Tucker K, Miron A, Apicella C, Tesoriero A, Bane A, Pike MC; ConFab Investigators, Ontario Cancer Genetics Network Investigators, Whittemore AS,** BRCA1 and BRCA2 mutation carriers, oral contraceptive use, and breast cancer before age 50, *Cancer Epidemiol Biomarkers Prev* 15:1863, 2006.
413. **Brohet RM, Goldgar DE, Easton DF, Antonious AC, Andrieu N, Chang-Claude J, Peock S, Eeles RA, Cook M, Chu C, Noguès C, Lasset C, Berthet P, Meijers-Heijboer H, Gerdes AM, Olsson H, Caldes T, van Leeuwen FE, Rookus MA,** Oral contraceptives and breast cancer risk in the international BRCA1/2 carrier cohort study: a report from EMBRACE, GENEPSO, GEO-HEBON, and the IBCCS Collaborating Group, *J Clin Oncol* 25:3831, 2007.
414. **Lee E, Ma H, McKean-Cowdin R, Van Den Berg D, Bernstein L, Henderson BE, Ursin G,** Effect of reproductive factors and oral contraceptives on breast cancer risk in BRCA1/2 mutation carriers and noncarriers: results from a population based study, *Cancer Epidemiol Biomarkers Prev* 17:3170, 2008.
415. **Figueiredo JC, Haile RW, Bernstein L, Malone KE, Largent J, Langholz B, Lynch CF, Bertelsen L, Capanu M, Concannon P, Borg A, Børresen-Dale AL, Diep A, Teraoka S, Torngren T, Xue S, Berstein JL,** Oral contraceptives and postmenopausal hormones and risk of contralateral breast cancer among BRCA1 and BRCA2 mutation carriers and noncarriers: the WECARE Study, *Breast Cancer Res Treat* 120:175, 2010.
416. **Nyante SJ, Gammon MD, Malone KE, Daling JR, Brinton LA,** The association between oral contraceptive use and lobular and ductal breast cancer in young women, *Int J Cancer* 122:936, 2007.
417. **Martinez ME, Grodstein F, Giovannucci E, Colditz GA, Speizer FE, Hennekens C, Rosner B, Willett WC, Stampfer MJ,** A prospective study of reproductive factors, oral contraceptive use, and risk of colorectal cancer, *Cancer Epidemiol Biomarkers Prev* 6:1, 1997.
418. **Fernandez E, La Vecchia C, Balducci A, Chatenoud L, Franceschi S, Negri E,** Oral contraceptives and colorectal cancer risk: a meta-analysis, *Br J Cancer* 84:722, 2001.
419. **Levi F, Pasche C, Lucchini F, La Vecchia C,** Oral contraceptives and colorectal cancer, *Dig Liver Dis* 35:85, 2003.
420. **Nichols HB, Trentham-Dietz A, Hampton JM, Newcomb PA,** Oral contraceptive use, reproductive factors, and colorectal cancer risk: findings from Wisconsin, *Cancer Epidemiol Biomarkers Prev* 14:1212, 2005.
421. **Hannaford P, Elliott A,** Use of exogenous hormones by women and colorectal cancer: evidence from the Royal College of General Practitioners' Oral Contraception Study, *Contraception* 71:95, 2005.
422. **Green A,** Oral contraceptives and skin neoplasia, *Contraception* 43:653, 1991.
423. **Hannaford PC, Villard-Mackintosh L, Vessey MP, Kay CR,** Oral contraceptives and malignant melanoma, *Br J Cancer* 63:430, 1991.
424. **Vessey MP, Painter R, Powell J,** Skin disorders in relation to oral contraception and other factors, including age, social class, smoking and body mass index, *Br J Dermatol* 143:815, 2000.
425. **Milne R, Vessey M,** The association of oral contraception with kidney cancer, colon cancer, gallbladder cancer (including extrahepatic bile duct cancer) and pituitary tumors, *Contraception* 43:667, 1991.
426. **Berkowitz RS, Bernstein MR, Harlow BL, Rice LW, Lage JM, Goldstein DP, Cramer DW,** Case-control study of risk factors for partial molar pregnancy, *Am J Obstet Gynecol* 173:788, 1995.
427. **Palmer JR, Driscoll SG, Rosenberg L, Berkowitz RS, Lurain JR, Soper J, Twiggs LB, Gershenson DM, Kohorn EI, Berman M, Shapiro S, Rao RS,** Oral contraceptive use and risk of gestational trophoblastic tumors, *J Natl Cancer Inst* 91:635, 1999.
428. **Parazzini F, Cipriani S, Mangili G, Garavaglia E, Guarnerio P, Ricci E, Benzi G, Salerio B, Polverino G, La Vecchia C,** Oral contraceptives and risk of gestational trophoblastic disease, *Contraception* 65:425, 2002.
429. **Horn-Ross PL, Morrow M, Ljung BM,** Menstrual and reproductive factors for salivary gland cancer risk in women, *Epidemiology* 10:528, 1999.
430. **Wiegratz I, Kutschera E, Lee JH, Moore C, Mellinger U, Winkler UH, Kuhl H,** Effect of four oral

- contraceptives on thyroid hormones, adrenal and blood pressure parameters, *Contraception* 67:361, 2003.
431. **Janerich DT, Dugan JM, Standfast SJ, Strite L**, Congenital heart disease and prenatal exposure to exogenous sex hormones, *Br Med J* i:1058, 1977.
  432. **Nora JJ, Nora AH, Blu J, Ingram J, Foster D**, Exogenous progestogen and estrogen implicated in birth defects, *JAMA* 240:837, 1978.
  433. **Heinonen OP, Slone D, Monson RR, Hook ER, Shapiro S**, Cardiovascular birth defects in antenatal exposure to female sex hormones, *N Engl J Med* 296:67, 1976.
  434. **Simpson JL, Phillips OP**, Spermicides, hormonal contraception and congenital malformations, *Adv Contracept* 6:141, 1990.
  435. **Michaelis J, Michaelis H, Gluck E, Koller S**, Prospective study of suspected associations between certain drugs administered during early pregnancy and congenital malformations, *Teratology* 27:57, 1983.
  436. **Bracken MB**, Oral contraception and congenital malformations in offspring: a review and meta-analysis of the prospective studies, *Obstet Gynecol* 76: 552, 1990.
  437. **Raman-Wilms L, Tseng AL, Wighardt S, Einarson TR, Koren G**, Fetal genital effects of first trimester sex hormone exposure: a meta-analysis, *Obstet Gynecol* 85:141, 1995.
  438. **Resseque LJ, Hick JF, Bruen JA, Noller KL, O'Fallon WM, Kurland LT**, Congenital malformations among offspring exposed in utero to progestins, Olmsted County, Minnesota, 1936–1974, *Fertil Steril* 43:514, 1985.
  439. **Katz Z, Lancet M, Skornik J, Chemke J, Mogilemer B, Klinberg M**, Teratogenicity of progestogens given during the first trimester of pregnancy, *Obstet Gynecol* 65:775, 1985.
  440. **Vessey MP, Smith MA, Yates D**, Return of fertility after discontinuation of oral contraceptives: influence of age and parity, *Br J Fam Plann* 11:120, 1986.
  441. **Linn S, Schoenbaum SC, Monson RR, Rosner B, Ryan KJ**, Delay in conception for former 'pill' users, *JAMA* 247:629, 1982.
  442. **Bracken MB, Hellenbrand KG, Holford TR**, Conception delay after oral contraceptive use: the effect of estrogen dose, *Fertil Steril* 53:21, 1990.
  443. **Bagwell MA, Coker AL, Thompson SJ, Baker ER, Addy CL**, Primary infertility and oral contraceptive steroid use, *Fertil Steril* 63:1161, 1995.
  444. **Farrow A, Hull MGR, Northstone K, Taylor H, Ford WCL, Golding J**, Prolonged use of oral contraception before a planned pregnancy is associated with a decreased risk of delayed conception, *Hum Reprod* 17:2754, 2002.
  445. **Cronin M, Schellschmidt I, Dinger J**, Rate of pregnancy after using drospirenone and other progestin-containing oral contraceptives, *Obstet Gynecol* 114:616, 2009.
  446. **Rothman KJ**, Fetal loss, twinning, and birth weight after oral-contraceptive use, *N Engl J Med* 297:468, 1977.
  447. **Ford JH, MacCormac L**, Pregnancy and lifestyle study: the long-term use of the contraceptive pill and the risk of age-related miscarriage, *Hum Reprod* 10:1397, 1995.
  448. **Rothman KJ, Liess J**, Gender of offspring after oral-contraceptive use, *N Engl J Med* 295:859, 1976.
  449. **Magidor S, Poalti H, Harlap S, Baras M**, Long-term follow-up of children whose mothers used oral contraceptives prior to contraception, *Contraception* 29:203, 1984.
  450. **Vessey M, Doll R, Peto R, Johnson B, Wiggins P**, A long-term follow-up study of women using different methods of contraception—an interim report, *J Biosoc Sci* 8:373, 1976.
  451. **Royal College of General Practitioners**, The outcome of pregnancy in former oral contraceptive users, *Br J Obstet Gynaecol* 83:608, 1976.
  452. **Gray RH, Campbell OM, Zacur HA, Labbok MH, MacRae SL**, Postpartum return of ovarian activity in nonbreastfeeding women monitored by urinary assays, *J Clin Endocrinol Metab* 64:645, 1987.
  453. **Campbell OM, Gray RH**, Characteristics and determinants of postpartum ovarian function in women in the United States, *Am J Obstet Gynecol* 169:55, 1993.
  454. **Kolata G**, Kung hunter-gatherers: feminism, diet and birth control, *Science* 185:932, 1974.
  455. **Short RV**, Lactation. The central control of reproduction, *Ciba Found Sympos* 45:73, 1976.
  456. **Thapa S, Short RV, Potts M**, Breastfeeding, birth spacing and their effects on child survival, *Nature* 335:679,

1988.

457. **Miller JE**, Birth intervals and perinatal health: an investigation of three hypotheses, *Fam Plann Perspect* 23:62, 1991.
458. **Wasalathanthri S, Tennekoon KH**, Lactational amenorrhea/anovulation and some of their determinants: a comparison of well-nourished and undernourished women, *Fertil Steril* 76:317, 2001.
459. **Labbok MH, Hight-Laukaran V, Peterson AE, Fletcher V, von Hertzen H, Van Look PFA**, Multicenter study of the lactational amenorrhea method (LAM): I. Efficacy, duration, and implications for clinical application, *Contraception* 55:327, 1997.
460. **Visness CM, Kennedy KI, Gross BA, Parenteau-Carreau S, Flynn AM, Brown JB**, Fertility of fully breast-feeding women in the early postpartum period, *Obstet Gynecol* 89:164, 1997.
461. **Perez A, Vela P, Masnick GS, Potter RG**, First ovulation after childbirth: the effect of breastfeeding, *Am J Obstet Gynecol* 114:1041, 1972.
462. **Diaz S, Peralta O, Juez G, Salvatierra AM, Casado ME, Duran E, Croxatto HB**, Fertility regulation in nursing women. I. The probability of conception in full nursing women living in an urban setting, *J Biosoc Sci* 14:329, 1982.
463. **McNeilly AS, Glasier A, Howie PW**, Endocrine control of lactational infertility, In: Dobbing J, ed. *Maternal Nutrition and Lactational Infertility*, Nevey/Raven Press, New York, 1985, p. 177.
464. **Rivera R, Kennedy KI, Ortiz E, Barrera M, Bhiwandiwalla PP**, Breast-feeding and the return to ovulation in Durango, Mexico, *Fertil Steril* 49:780, 1988.
465. **Lewis PR, Brown JB, Renfree MB, Short RV**, The resumption of ovulation and menstruation in a well-nourished population of women breastfeeding for an extended period of time, *Fertil Steril* 55:529, 1991.
466. **Robson KM, Brant HA, Kumar R**, Maternal sexuality during first pregnancy and after childbirth, *Br J Obstet Gynaecol* 88:881, 1981.
467. **Glazener CMA**, Sexual function after childbirth: women's experiences, persistent morbidity and lack of professional recognition, *Br J Obstet Gynaecol* 104:330, 1997.
468. **Elliott SA, Watson JP**, Sex during pregnancy and the first postnatal year, *J Psychosom Res* 29:541, 1985.
469. **Connolly A, Thorp J, Pahel L**, Effects of pregnancy and childbirth on postpartum sexual function: a longitudinal prospective study, *Int Urogynecol J Pelvic Floor Dysfunct* 16:263, 2005.
470. **Woranit W, Taneepanichskul S**, Sexual function during the postpartum period, *J Med Assoc Thai* 90:1744, 2007.
471. **Rowland M, Foxcroft L, Hopman WM, Patel R**, Breastfeeding and sexuality immediately post partum, *Can Fam Physician* 51:1366, 2005.
472. **Grudzinskas JG, Atkinson L**, Sexual function during the puerperium, *Arch Sex Behav* 13:85, 1984.
473. **Egbonu I, Ezechukwu CC, Chukwuka JO, Ikechebelu JI**, Breast-feeding, return of menses, sexual activity and contraceptive practices among mothers in the first six months of lactation in Onitsha, South Eastern Nigeria, *J Obstet Gynaecol* 25:500, 2005.
474. **Short RV, Lewis PR, Renfree MB, Shaw G**, Contraceptive effects of extended lactational amenorrhoea: beyond the Bellagio Consensus, *Lancet* 337:715, 1991.
475. **Pérez A, Labbok MH, Queenan JT**, Clinical study of the lactational amenorrhoea method for family planning, *Lancet* 339:968, 1992.
476. **Diaz S, Aravena R, Cardenas H, Casado ME, Miranda P, Schiappacasse V, Croxatto HB**, Contraceptive efficacy of lactational amenorrhea in urban Chilean women, *Contraception* 43:335, 1991.
477. **Kazi A, Kennedy KI, Visness CM, Khan T**, Effectiveness of the lactational amenorrhea method in Pakistan, *Fertil Steril* 64:717, 1995.
478. **Kennedy KI, Rivera R, McNeilly AS**, Consensus statement on the use of breastfeeding as a family planning method, Bellagio, Italy, *Contraception* 39:477, 1989.
479. **Ramos R, Kennedy KI, Visness CM**, Effectiveness of lactational amenorrhoea in preventing pregnancy in Manila, The Philippines, *Br Med J* 313:909, 1996.
480. **World Health Organization Task Force on Methods for the Natural Regulation of Fertility**, The World Health Organization multinational study of breast-feeding and lactational amenorrhea. I. Description of infant

feeding patterns and the return of menses, *Fertil Steril* 70:448, 1998.

481. **World Health Organization Task Force on Methods for the Natural Regulation of Fertility**, The World Health Organization multinational study of breast-feeding and lactational amenorrhea. II. Factors associated with the length of amenorrhea, *Fertil Steril* 70:461, 1998.
482. **World Health Organization Task Force on Methods for the Natural Regulation of Fertility**, The World Health Organization multinational study of breast-feeding and lactational amenorrhea. III. Pregnancy during breast-feeding, *Fertil Steril* 72:431, 1999.
483. **World Health Organization Task Force on Methods for the Natural Regulation of Fertility**, The World Health Organization multinational study of breast-feeding and lactational amenorrhea. IV. Postpartum bleeding and lochia in breast-feeding women, *Fertil Steril* 72:441, 1999.
484. **Gray RH, Campbell OM, Apelo R, Eslami SS, Zacur H, Ramos RM, Gehret JC, Labbok MH**, Risk of ovulation during lactation, *Lancet* 335:25, 1990.
485. **Gross BA**, Natural family planning indicators of ovulation, *Clin Reprod Fertil* 5:91, 1987.
486. **Kremer JAM, Thomas CMG, Rolland R, van der Heijden PF, Thomas CM, Lancranjan I**, Return of gonadotropic function in postpartum women during bromocriptine treatment, *Fertil Steril* 51:622, 1989.
487. **Haartsen JE, Heineman MJ, Elings M, Evers JLH, Lancranjan I**, Resumption of pituitary and ovarian activity post-partum: endocrine and ultrasonic observations in bromocriptine-treated women, *Hum Reprod* 7:746, 1992.
488. **Shikary ZK, Bertrabet S, Patel ZM, Paytel S, Joshi JV, Toddywala VA, Toddywala SP, Patel DM, Jhaveri K, Saxena BN**, ICMR task force study on hormonal contraception. Transfer of levonorgestrel administered through different drug delivery systems from the maternal circulation into the newborn's circulation via breast milk, *Contraception* 35:477, 1987.
489. **Betrabet SS, Shikary ZK, Toddywala VS, Toddywala SP, Patel D, Saxena BN**, Transfer of norethisterone (NET) and levonorgestrel (LNG) from a single tablet into the infant's circulation through the mother's milk, *Contraception* 35:517, 1987.
490. **Dorea JG, Miazaki ES**, The effects of oral contraceptive use on iron and copper concentrations in breast milk, *Fertil Steril* 72:297, 1999.
491. **Diaz S, Peralta O, Juez G, Herreros C, Casado ME, Salvatierra AM, Miranda P, Durn E, Croxatto HB**, Fertility regulation in nursing women: III. Short-term influence of a low-dose combined oral contraceptive upon lactation and infant growth, *Contraception* 27:1, 1982.
492. **Croxatto HB, Diaz S, Peralta O, Juez G, Herreros C, Casado ME, Salvatierra AM, Miranda P, Durn E**, Fertility regulation in nursing women: IV. Long-term influence of a low-dose combined oral contraceptive initiated at day 30 postpartum upon lactation and child growth, *Contraception* 27:13, 1983.
493. **Peralta O, Diaz S, Juez G, Herreros C, Casado ME, Salvatierra AM, Miranda P, Durn E, Croxatto HB**, Fertility regulation in nursing women: V. Long-term influence of a low-dose combined oral contraceptive initiated at day 90 postpartum upon lactation and infant growth, *Contraception* 27:27, 1983.
494. **WHO, Special Programme of Research, Development, and Research Training in Human Reproduction, Task Force on Oral Contraceptives**, Effects of hormonal contraceptives on milk volume and infant growth, *Contraception* 30:505, 1984.
495. **WHO Task Force for Epidemiological Research on Reproductive Health, Special Programme of Research, Development and Research Training in Human Reproduction**, Progestogen-only contraceptives during lactation. I. Infant growth, *Contraception* 50:35, 1994.
496. **WHO Task Force for Epidemiological Research on Reproductive Health, Special Programme of Research, Development and Research Training in Human Reproduction**, Progestogen-only contraceptives during lactation. II. Infant development, *Contraception* 50:55, 1994.
497. **Nilsson S, Melbin T, Hofvander Y, Sundelin C, Valentin J, Nygren KG**, Long-term follow-up of children breast-fed by mothers using oral contraceptives, *Contraception* 34:443, 1986.
498. **McCann MF, Moggia AV, Hibbins JE, Potts M, Becker C**, The effects of a progestin-only oral contraceptive (levonorgestrel 0.03 mg) on breast-feeding, *Contraception* 40:635, 1989.
499. **Moggia AV, Harris GS, Dunson TR, Diaz R, Moggia MS, Ferrer MA, McMullen SL**, A comparative

study of a progestin-only oral contraceptive versus non-hormonal methods in lactating women in Buenos Aires, Argentina, *Contraception* 44:31, 1991.

500. **Caird LE, Reid-Thomas V, Hannan WJ, Gow S, Glasier AF**, Oral progestogen-only contraception may protect against loss of bone mass in breast-feeding women, *Clin Endocrinol* 41:739, 1994.
501. **Haldeman LD, Nelson AL**, Impact of early postpartum administration of progestin-only hormonal contraceptives compared with nonhormonal contraceptives on short-term breast-feeding patterns, *Am J Obstet Gynecol* 186: 1250, 2002.
502. **World Health Organization Collaborative Study of Cardiovascular Disease and Steroid Hormone Contraception**, Cardiovascular disease and use of oral and injectable progestogen-only contraceptives and combined injectable contraceptives. Results of an international, multicenter, case-control study, *Contraception* 57:315, 1998.
503. **Heinemann LA, Assmann A, Do Minh T, Garbe E**, Oral progestogen-only contraceptives and cardiovascular risk: results from the Transnational Study on Oral Contraceptives and the Health of Young Women, *Eur J Contracept Reprod Health Care* 4:67, 1999.
504. **Heit JA, Kobbervig CE, James AH, Petterson TM, Bailey KR, Melton LJI**, Trends in the incidence of venous thromboembolism during pregnancy or postpartum: a 30-year population-based study, *Ann Intern Med* 143: 697, 2005.
505. **James AH, Jamison MG, Brancazio LR, Myers ER**, Venous thromboembolism during pregnancy and the postpartum period: incidence, risk factors, and mortality, *Am J Obstet Gynecol* 194:1311, 2006.
506. **Blanco-Molina A, Trujillo-Santos J, Criado J, Lopez L, Lecumberri R, Gutierrez R, Monreal M; RIETE Investigators**, Venous thromboembolism during pregnancy or postpartum: findings from the RIETE registry, *Thromb Haemost* 97:186, 2007.
507. **James AH, Tapson VG, Goldhaber SZ**, Thrombosis during pregnancy and the postpartum period, *Am J Obstet Gynecol* 193:216, 2005.
508. **Samuelsson E, Hedenmalm K, Persson I**, Mortality from venous thromboembolism in young Swedish women and its relation to pregnancy and use of oral contraceptives—an approach to specifying rates, *Eur J Epidemiol* 20:509, 2005.
509. **Samuelsson E, Hellgren M, Högberg U**, Pregnancy-related deaths due to pulmonary embolism in Sweden, *Acta Obstet Gynecol Scand* 86:435, 2007.
510. **Huerta C, Johansson S, Wallander MA, García Rodríguez LA**, Risk factors and short-term mortality of venous thromboembolism diagnosed in the primary care setting in the United Kingdom, *Arch Intern Med* 167: 935, 2007.
511. **Pituitary Adenoma Study Group**, Pituitary adenomas and oral contraceptives: a multicenter case-control study, *Fertil Steril*, 39:753, 1983.
512. **Shy FKK, McTiernan AM, Daling JR, Weiss NS**, Oral contraceptive use and the occurrence of pituitary prolactinomas, *JAMA* 249:2204, 1983.
513. **Wingrave SJ, Kay CR, Vessey MP**, Oral contraceptives and pituitary adenomas, *Br Med J* 280:685, 1980.
514. **Hulting A-L, Werner S, Hagenfeldt K**, Oral contraceptives do not promote the development or growth of prolactinomas, *Contraception* 27:69, 1983.
515. **Corenblum B, Donovan L**, The safety of physiological estrogen plus progestin replacement therapy and oral contraceptive therapy in women with pathological hyperprolactinemia, *Fertil Steril* 59:671, 1993.
516. **Testa G, Vegetti W, Motta T, Alagna F, Bianchedi D, Carlucci C, Bianchi M, Parazzini F, Crosignani PG**, Two-year treatment with oral contraceptives in hyperprolactinemic patients, *Contraception* 58:69, 1998.
517. **Furuhjelm M, Carlstrom K**, Amenorrhea following use of combined oral contraceptives, *Acta Obstet Gynecol Scand* 52:373, 1973.
518. **Shearman RP, Smith ID**, Statistical analysis of relationship between oral contraceptives, secondary amenorrhea and galactorrhea, *J Obstet Gynaecol Br Commonw* 79:654, 1972.
519. **Jacobs HS, Knuth UA, Hull MGR, Franks S**, Post “pill” amenorrhea—cause or coincidence?, *Br Med J* ii:940, 1977.
520. **Vessey MP, Hannaford P, Mant J, Painter R, Frith P, Chappel D**, Oral contraception and eye disease:

findings in two large cohort studies, *Br J Ophthalmol* 82(5):538–542, 1998.

521. **Vessey MP, Hannaford P, Mant J, Painter R, Frith P, Chappel D**, Oral contraception and eye disease: findings in two large cohort studies, *Br Med J* 82:538, 1998.
522. **Villard-Mackintosh L, Vessey MP**, Oral contraceptives and reproductive factors in multiple sclerosis incidence, *Contraception* 47:161, 1993.
523. **Thorogood M, Hannaford PC**, The influence of oral contraceptives on the risk of multiple sclerosis, *Br J Obstet Gynaecol* 105:1296, 1998.
524. **Hernan MA, Hohol MJ, Olek MJ, Spiegelman D, Ascherio A**, Oral contraceptives and the incidence of multiple sclerosis, *Neurology* 55:848, 2000.
525. **Alonso A, Jick SS, Olek MJ, Ascherio A, Jick H, Hernan MA**, Recent use of oral contraceptives and the risk of multiple sclerosis, *Arch Neurol* 62: 1362, 2005.
526. **Holmqvist P, Hammar M, Landtblom AM, Brynhildsen J**, Symptoms of multiple sclerosis in women in relation to cyclical hormone changes, *Eur J Contracept Reprod Health Care* 14:365, 2009.
527. **Costello Daly C, Helling-Giese GE, Mati JK, Hunter DJ**, Contraceptive methods and the transmission of HIV: implications for family planning, *Genitourin Med* 70:110, 1994.
528. **Taneepanichskul S, Phuapradit W, Chaturachinda K**, Association of contraceptives and HIV-1 infection in Thai female commercial sex workers, *Aust N Z J Obstet Gynaecol* 37:86, 1997.
529. **Kapiga SH, Lyamuya EF, Lwihula GK, Hunter DJ**, The incidence of HIV infection among women using family planning methods in Dar-es-Salaam, Tanzania, *AIDS* 12:75, 1998.
530. **Cejtin HE, Jacobson L, Springer G, Watts DH, Levine AJ, Greenblatt R, Anastos K, Minkoff HL, Massad LS, Schmidt JB**, Effect of hormonal contraceptive use on plasma HIV-1-RNA levels among HIV-infected women, *AIDS* 17:1702, 2003.
531. **Richardson BA, Otieno PA, Mbori-Ngacha D, Overbaugh J, Farquhar C, John-Stewart GC**, Hormonal contraception and HIV-1 disease progression among postpartum Kenyan women, *AIDS* 21:749, 2007.
532. **El-Ibiary SY, Cocohoba JM**, Effects of HIV antiretrovirals on the pharmacokinetics of hormonal contraceptives, *Eur J Contracept Reprod Health Care* 13:123, 2008.
533. **Westrom I**, Incidence, prevalence, and trends of acute pelvic inflammatory disease and its consequences in industrialized countries, *Am J Obstet Gynecol* 138:880, 1980.
534. **Eschenbach DA, Harnisch JP, Holmes KK**, Pathogenesis of acute pelvic inflammatory disease: role of contraception and other risk factors, *Am J Obstet Gynecol* 128:838, 1977.
535. **Rubin GL, Ory WH, Layde PM**, Oral contraceptives and pelvic inflammatory disease, *Am J Obstet Gynecol* 140:630, 1980.
536. **Senanayake P, Kramer DG**, Contraception and the etiology of pelvic inflammatory diseases: new perspectives, *Am J Obstet Gynecol* 138:852, 1980.
537. **Panser LA, Phipps WR**, Type of oral contraceptive in relation to acute, initial episodes of pelvic inflammatory disease, *Contraception* 43:91, 1991.
538. **Svensson L, Westrom L, Mardh P**, Contraceptives and acute salpingitis, *JAMA* 251:2553, 1984.
539. **Wolner-Hanssen P**, Oral contraceptive use modifies the manifestations of pelvic inflammatory disease, *Br J Obstet Gynaecol* 93:619, 1986.
540. **Cates W Jr, Washington AE, Rubin GL, Peterson HB**, The pill, chlamydia and PID, *Fam Plann Perspect* 17:175, 1985.
541. **Cottingham J, Hunter D**, Chlamydia trachomatis and oral contraceptive use: a quantitative review, *Genitourin Med* 68:209, 1992.
542. **Critchlow CW, Wolner-Hanssen P, Eschenbach DA, Kiviat NB, Koutsky LA, Stevens CE, Holmes KK**, Determinants of cervical ectopia and of cervicitis: age, oral contraception, specific cervical infection, smoking, and douching, *Am J Obstet Gynecol* 173:534, 1995.
543. **Cramer DW, Goldman MB, Schiff I, Belisla S, Albrecht B, Stadel B, Gibson M, Wilson E, Stillman R, Thompson I**, The relationship of tubal infertility to barrier method and oral contraceptive use, *JAMA* 257:2446, 1987.
544. **Wolner-Hanssen P, Eschenbach DA, Paavonen J, Kiviat N, Stevens CE, Critchlow C, DeRouen T**,

- Holmes KK, Decreased risk of symptomatic chlamydial pelvic inflammatory disease associated with oral contraceptive use, *JAMA* 263:54, 1990.
545. **Spinillo A, Gorini G, Piazzini G, Balataro F, Monaco A, Zara F**, The impact of oral contraception on chlamydial infection among patients with pelvic inflammatory disease, *Contraception* 54:163, 1996.
546. **Ness RB, Keder LM, Soper DE, Amortegui AJ, Gluck J, Wiesenfeld H, Sweet RL, Rice PA, Peipert JF, Donegan SP, Kanbour-Shakir A**, Oral contraception and the recognition of endometritis, *Am J Obstet Gynecol* 176:580, 1997.
547. **Ness RB, Soper DE, Holley RL, Peipert J, Randall H, Sweet RL, Sondheimer SJ, et al.; for the PID Evaluation and Clinical Health (PEACH) Study Investigators**, Hormonal and barrier contraception and risk of upper genital tract disease in the PID Evaluation and Clinical Health (PEACH) study, *Am J Obstet Gynecol* 185:121, 2001.
548. **Barbone F, Austin H, Louv WC, Alexander WJ**, A follow-up study of methods of contraception, sexual activity, and rates of trichomoniasis, candidiasis, and bacterial vaginosis, *Am J Obstet Gynecol* 163:510, 1990.
549. **Shoubnikova M, Hellberg D, Nilsson S, Mårdh P-A**, Contraceptive use in women with bacterial vaginosis, *Contraception* 55:355, 1997.
550. **Baeten JM, Nyange PM, Richardson BA, Lavreys L, Chohan B, Martin HL, Jr, Mandaliya K, Ndiya-Achola JO, Bwayo JJ, Kreiss JK**, Hormonal contraception and risk of sexually transmitted disease acquisition: results from a prospective study, *Am J Obstet Gynecol* 185:380, 2001.
551. **Rifkin SB, Smith MR, Brotman RM, Gindi RM, Erbeling EJ**, Hormonal contraception and risk of bacterial vaginosis diagnosis in an observational study of women attending STD clinics in Baltimore, MD, *Contraception* 80:63, 2009.
552. **Roumen FJME, Boon ME, van Velzen D, Dieben TOM, Coelingh Bennink HJT**, The cervico-vaginal epithelium during 20 cycles' use of a combined contraceptive vaginal ring, *Hum Reprod* 11:2443, 1996.
553. **Davies GC, Feng LX, Newton JR, Dieben TO, Coelingh Bennink HJ**, The effects of a combined contraceptive vaginal ring releasing ethinylloestradiol and 3-keto-desogestrel on vaginal flora, *Contraception* 45:511, 1992.
554. **Veres S, Miller L, Burington B**, A comparison between the vaginal ring and oral contraceptives, *Obstet Gynecol* 104:555, 2004.
555. **Stewart FH, Harper CC, Ellertson CE, Grimes DA, Sawaya GF, Trussell J**, Clinical breast and pelvic examination requirements for hormonal contraception, Current practice vs evidence, *JAMA* 285:2231, 2001.
556. **Milsom I, Sundell G, Andersch B**, A longitudinal study of contraception and pregnancy outcome in a representative sample of young Swedish women, *Contraception* 43:111, 1991.
557. **Letterie GS, Chow GE**, Effect of "missed" pills on oral contraceptive effectiveness, *Obstet Gynecol* 79:979, 1992.
558. **Westhoff CL, Kerns J, Morroni C, Tiezzi L, Aikins-Murphy P**, Quick-start: a novel oral contraceptive initiation method, *Contraception* 66:141, 2002.
559. **Westhoff C, Morroni C, Kerns J, Murphy PA**, Bleeding patterns after immediate vs. conventional oral contraceptive initiation: a randomized, controlled trial, *Fertil Steril* 79:322, 2003.
560. **Potter L, Oakley D, de Leon-Wong E, Cañamar R**, Measuring compliance among oral contraceptive users, *Fam Plann Perspect* 28:154, 1996.
561. **Killick SR, Bancroft K, Oelbaum S, Morris J, Elstein M**, Extending the duration of the pill-free interval during combined oral contraception, *Adv Contracept* 6:33, 1990.
562. **Rosenberg MJ, Waugh MS, Higgins JE**, The effect of desogestrel, gestodene, and other factors on spotting and bleeding, *Contraception* 53:85, 1996.
563. **Westhoff C, Jones K, Robilotto C, Heartwell S, Edwards S, Zieman M, Cushman L**, Smoking and oral contraceptive continuation, *Contraception* 79:375, 2009.
564. **Krettek SE, Arkin SI, Chaisilwattana P, Monif GR**, Chlamydia trachomatis in patients who used oral contraceptives and had intermenstrual spotting, *Obstet Gynecol* 81:728, 1993.
565. **Sulak PJ, Kuehl TJ, Coffee A, Willis S**, Prospective analysis of occurrence and management of breakthrough bleeding during an extended oral contraceptive regimen, *Am J Obstet Gynecol* 195:935, 2006.



566. **Lemay A, Dewailly SD, Grenier R, Huard J**, Attenuation of mild hyperandrogenic activity in postpubertal acne by a triphasic oral contraceptive containing low doses of ethinyl estradiol and d, l-norgestrel, *J Clin Endocrinol Metab* 71:8, 1990.
567. **Mango D, Ricci S, Manna P, Miggiano GAD, Serra GB**, Clinical and hormonal effects of ethinylestradiol combined with gestodene and desogestrel in young women with acne vulgaris, *Contraception* 53:163, 1996.
568. **Thorneycroft IH, Stanczyk FZ, Bradshaw KD, Ballagh SA, Nichols M, Weber ME**, Effect of low-dose oral contraceptives on androgenic markers and acne, *Contraception* 60:255, 1999.
569. **Rosen MP, Breitkopf DM, Nagamani M**, A randomized controlled trial of second- versus third-generation oral contraceptives in the treatment of acne vulgaris, *Am J Obstet Gynecol* 188:1158, 2003.
570. **Maloney JM, Dietze P Jr, Watson D, Niknian M, Lee-Rugh S, Sampson-Landers C, Korner P**, Treatment of acne using a 3-milligram drospirenone/20-microgram ethinyl estradiol oral contraceptive administered in a 24/4 regimen. A randomized controlled trial, *Obstet Gynecol* 112:773, 2008.
571. **Palombo-Kinne E, Schellschmidt I, Schumacher U, Gräser T**, Efficacy of a combined oral contraceptive containing 0.030 mg ethinylestradiol/2 mg dienogest for the treatment of papulopustular acne in comparison with placebo and 0.035 mg ethinylestradiol/2 mg cyproterone acetate, *Contraception* 79:282, 2009.
572. **Cassidenti DL, Paulson RJ, Serafini P, Stanczyk FZ, Lobo RA**, Effects of sex steroids on skin 5 $\alpha$ -reductase activity in vitro, *Obstet Gynecol* 78:103, 1991.
573. **Grimes DA, Hughes JM**, Use of multiphasic oral contraceptives and hospitalizations of women with functional ovarian cysts in the United States, *Obstet Gynecol* 73:1037, 1989.
574. **Holt VL, Cushing-Haugen KL, Daling JR**, Oral contraceptives, tubal sterilization, and functional ovarian cyst risk, *Obstet Gynecol* 102:252, 2003.
575. **Vessey M, Metcalfe A, Wells C, McPherson K, Westhoff C, Yeates C**, Ovarian neoplasms, functional ovarian cysts, and oral contraceptives, *Br Med J* 294:1518, 1987.
576. **Lanes SF, Birmann B, Walker AM, Singer S**, Oral contraceptive type and functional ovarian cysts, *Am J Obstet Gynecol* 166:956, 1992.
577. **Holt VL, Daling JR, McKnight B, Moore D, Stergachis A, Weiss NS**, Functional ovarian cysts in relation to the use of monophasic and triphasic oral contraceptives, *Obstet Gynecol* 79:529, 1992.
578. **Young RL, Snabes MC, Frank ML, Reilly M**, A randomized, double-blind, placebo-controlled comparison of the impact of low-dose and triphasic oral contraceptives on follicular development, *Am J Obstet Gynecol* 167:678, 1992.
579. **Grimes DA, Godwin AJ, Rubin A, Smith JA, Lacarra M**, Ovulation and follicular development associated with three low-dose oral contraceptives: a randomized controlled trial, *Obstet Gynecol* 83:29, 1994.
580. **Neely JL, Abate M, Swinker M, D'Angio R**, The effect of doxycycline on serum levels of ethinyl estradiol, norethindrone, and endogenous progesterone, *Obstet Gynecol* 77:416, 1991.
581. **Murphy AA, Zacur HA, Charache P, Burkman RT**, The effect of tetracycline on levels of oral contraceptives, *Am J Obstet Gynecol* 164:28, 1991.
582. **Back DJ, Tija J, Martin C, Millar E, Mant T, Morrison P, Orme P**, The lack of interaction between temafloxacin and combined oral contraceptive steroids, *Contraception* 43:317, 1991.
583. **Csemiczky G, Alvendal C, Landgren BM**, Risk for ovulation in women taking a low-dose oral contraceptive (Microgynon) when receiving antibacterial treatment with a fluoroquinolone (ofloxacin), *Adv Contracept* 12:101, 1996.
584. **Dogterom P, van den Heuvel MW, Thomsen T**, Absence of pharmacokinetic interactions of the combined contraceptive vaginal ring NuvaRing with oral amoxicillin or doxycycline in two randomised trials, *Clin Pharmacokinet* 44:429, 2005.
585. **Helms SE, Bredle DL, Zajic J, Jarjoura D, Brodell RT, Krishnarao I**, Oral contraceptive failure rates and oral antibiotics, *J Am Acad Dermatol* 36: 705, 1997.
586. **Schöller-Gyüre M, Kakuda TN, Woodfall B, Aharchi F, Peeters M, Vandermeulen K, Hoetelmans RMW**, Effect of steady-state etravirine on the pharmacokinetics and pharmacodynamics of ethinylestradiol and norethindrone, *Contraception* 80:44, 2009.
587. **Markowitz JS, Donovan JL, De Vane CL, Taylor RM, Ruan Y, Wang J-S, Chavin KD**, Effect of St

- John's Wort on drug metabolism by induction of cytochrome P450 3A4 enzyme, *JAMA* 290:1500, 2003.
588. **Szoka PR, Edgren RA**, Drug interactions with oral contraceptives: compilation and analysis of an adverse experience report database, *Fertil Steril* 49(Suppl):31S, 1988.
  589. **Mitchell MC, Hanew T, Meredith CG, Schenker S**, Effects of oral contraceptive steroids on acetaminophen metabolism and elimination, *Clin Pharmacol Ther* 34:48, 1983.
  590. **Gupta KC, Joshi JV, Hazari K, Pohujani SM, Satoskjar RS**, Effect of low estrogen combination oral contraceptives on metabolism of aspirin and phenylbutazone, *Int J Clin Pharmacol Ther Toxicol* 20:511, 1982.
  591. **Lipton RB, Vigal ME, Diamond MP, Freitag F, Reed ML, Stewart WF**, Migraine prevalence, disease burden, and the need for preventive therapy, *Neurology* 68:343, 2007.
  592. **Curtis KM, Chrisman CE, Peterson HB**, Contraception for women in selected circumstances, *Obstet Gynecol* 99:1100, 2002.
  593. **Tietjen GE**, The relationship of migraine and stroke, *Neuroepidemiology* 19:13, 2000.
  594. **Chang CL, Donaghy M, Poulter N**, Migraine and stroke in young women: case-control study, *Br Med J* 318:13, 1999.
  595. **Donaghy M, Chang CL, Poulter N**, Duration, frequency, recency, and type of migraine and the risk of ischaemic stroke in women of childbearing age, *J Neurol Neurosurg Psychiatry* 73:747, 2002.
  596. **Tzourio C, Tehindranarielo A, Iglésias S, Alpérovitch A, Chgedru F, d'Anglejan-Chatillon J, Bousser M-G**, Case-control study of migraine and risk of ischaemic stroke in young women, *Br Med J* 310:830, 1995.
  597. **Lidegaard Ø**, Oral contraceptives, pregnancy and the risk of cerebral thromboembolism: the influence of diabetes, hypertension, migraine and previous thrombotic disease, *Br J Obstet Gynaecol* 102:153, 1995.
  598. **MacClellan LR, Giles W, Cole J, Wozniak M, Stern B, Mitchell BD, Kittner SJ**, Probable migraine with visual aura and risk of ischemic stroke: the stroke prevention in young women study, *Stroke* 38:2438, 2007.
  599. **Friedman AJ, Thomas PP**, Does low-dose combination oral contraceptive use affect uterine size or menstrual flow in premenopausal women with leiomyomas?, *Obstet Gynecol* 85:631, 1995.
  600. **Mattson RH, Cramer JA, Darney PD, Naftolin F**, Use of oral contraceptives by women with epilepsy, *JAMA* 256:238, 1986.
  601. **Vessey M, Painter R, Yeates D**, Oral contraception and epilepsy: findings in a large cohort study, *Contraception* 66:77, 2002.
  602. **Klostervskov Jensen P, Saano V, Haring P, Svenstrup B, Menge GP**, Possible interaction between oxcarbazepine and an oral contraceptive, *Epilepsia* 33:1149, 1992.
  603. **Rosenfeld WE, Doose DR, Walker SA, Nayak RK**, Effect of topiramate on the pharmacokinetics of an oral contraceptive containing norethindrone and ethinyl estradiol in patients with epilepsy, *Epilepsia* 38:317, 1997.
  604. **Fattore C, Cipolla G, Gatti G, Limido GL, Sturm Y, Bernasconi C, Perucca E**, Induction of ethinylestradiol and levonorgestrel metabolism by oxcarbazepine in healthy women, *Epilepsia* 40:783, 1999.
  605. **Sidhu J, Job S, Singh S, Philipson R**, The pharmacokinetic and pharmacodynamic consequences of the coadministration of lamotrigine and a combined oral contraceptive in healthy female subjects, *Br J Clin Pharmacol* 61:191, 2006.
  606. **Galimberti CA, Mazzucchelli I, Arbasino C, Canevini MP, Fattore C, Petrucca E**, Increased apparent oral clearance of valproic acid during intake of combined contraceptive steroids in women with epilepsy, *Epilepsia* 47:1569, 2006.
  607. **Montouris G**, Importance of monotherapy in women across the reproductive cycle, *Neurology* 69:S10, 2007.
  608. **Wegner I, Edelbroek PM, Bulk S, Lindhout D**, Lamotrigine kinetics within the menstrual cycle, after menopause, and with oral contraceptives, *Neurology* 73:1388, 2009.
  609. **Bounds W, Guillebaud J**, Observational series on women using the contraceptive Mirena concurrently with anti-epileptic and other enzyme-inducing drugs, *J Fam Plann Reprod Health Care* 28:78, 2002.
  610. **Lutcher CL, Milner PF**, Contraceptive-induced vascular occlusive events in sickle cell disorders—fact or fiction? (abstract), *Clin Res* 34:217A, 1986.
  611. **Yoong WC, Tuck SM, Yardumian A**, Red cell deformability in oral contraceptive pill users with sickle cell

- anemia, *Br J Haematol* 104:868, 1999.
612. **DeCeular K, Gruber C, Hayes R, Serjeant GR**, Medroxyprogesterone acetate and homozygous sickle-cell disease, *Lancet* ii:229, 1982.
  613. **Jungers P, Dougados M, Pelissier L, Kuttann F, Tron F, Lesavre P, Bach JF**, Influence of oral contraceptive therapy on the activity of systemic lupus erythematosus, *Arthritis Rheum* 25:618, 1982.
  614. **Bernier M-O, Mikaeloff Y, Hudson M, Suissa S**, Combined oral contraceptive use and the risk of systemic lupus erythematosus, *Arthritis Rheum* 61:476, 2009.
  615. **Petri M, Robinson C**, Oral contraceptives and systemic lupus erythematosus, *Arthritis Rheum* 40:797, 1997.
  616. **Sánchez-Guerrero J, Uribe AG, Jiménez-Santana L, Mestanza-Peralta M, Lara-Reyes P, Seuc AH, Cravioto M**, A trial of contraceptive methods in women with systemic lupus erythematosus, *N Engl J Med* 353:2539, 2005.
  617. **Petri M, Kim MY, Kalunian KC, Grossman J, Hahn BH, Sammaritano LR, Lockshin M, Merrill JT, Belmont HM, Askanase AD, McCune WJ, Hearsh-Holmes M, Dooley MA, Von Feldt J, Friedman A, Tan M, Davis J, Cronin M, Diamond B, Mackay M, Sigler L, Fillius M, Rupel A, Licciardi F, Buyon JP; for the OC-SELENA Trial**, Combined oral contraceptives in women with systemic lupus erythematosus, *N Engl J Med* 353:2550, 2005.
  618. **Knopp RH, LaRosa JC, Burkman RT Jr**, Contraception and dyslipidemia, *Am J Obstet Gynecol* 168:1994, 1993.
  619. **Abdollahi M, Cushman M, Rosendaal FR**, Obesity: risk of venous thromboembolism and the interaction with coagulation factor levels and oral contraceptive use, *Thromb Haemost* 89:493, 2003.
  620. **Nightingale AL, Lawrenson RA, Simpson EL, Williams TJ, MacRae KD, Farmer RD**, The effects of age, body mass index, smoking and general health on the risk of venous thromboembolism in users of combined oral contraceptives, *Eur J Contracept Reprod Health Care* 5:265, 2000.
  621. **Larsen TB, Sorensen HT, Gislum M, Johnson SP**, Maternal smoking, obesity, and the risk of thromboembolism during pregnancy and the puerperium: a population-based nested control study, *Thromb Res* 120:505, 2007.
  622. **Holt VL, Cushing-Haugen KL, Daling JR**, Body weight and risk of oral contraceptive failure, *Obstet Gynecol* 99:820, 2002.
  623. **Zieman M, Guillebaud J, Weisberg E, Shangold GA, Fisher AC, Creasy GW**, Contraceptive efficacy and cycle control with the Ortho Evra™/Evra™ transdermal system: the analysis of pooled data, *Fertil Steril* 77(Suppl 2):S13, 2002.
  624. **Norris PM, Kamat A, Estes C**, Contraceptive failure in overweight patients taking combination oral contraceptive pills, *Contraception*, 68:Abstract 16, 2003.
  625. **Holt VL, Scholes D, Wicklund KG, Cushing-Haugen KL, Daling JR**, Body mass index, weight, and oral contraceptive failure risk, *Obstet Gynecol* 105:46, 2005.
  626. **Brunner LR, Hogue CJ**, The role of body weight in oral contraceptive failure: results from the 1995 National Survey of Family Growth, *Ann Epidemiol* 15:492, 2005.
  627. **Brunner LR, Hogue CJ**, The association between body weight, unintended pregnancy resulting in a livebirth, and contraception at the time of conception, *Matern Child Health J* 9:413, 2005.
  628. **Dinger JC, Cronin M, Möhner S, Schellschmidt I, Minh TD, Westhoff C**, Oral contraceptive effectiveness according to body mass index, weight, age, and other factors, *Am J Obstet Gynecol* 201:263.e1, 2009.
  629. **Archer DF, Maheux R, DelConte A, O'Brien FB; North American Levonorgestrel Study Group**, Efficacy and safety of a low-dose monophasic combination oral contraceptive containing 100 mg levonorgestrel and 20 mg ethinyl estradiol (Alesse), *Am J Obstet Gynecol* 181:S39, 1999.
  630. **Edelman AB, Carlson NE, Cherala G, Munar MY, Stouffer RL, Cameron JL, Stanczyk FZ, Jensen JT**, Impact of obesity on oral contraceptive pharmacokinetics and hypothalamic-pituitary-ovarian activity, *Contraception* 80:119, 2009.
  631. **Victor A, Odland V, Kral JG**, Oral contraceptive absorption and sex hormone binding globulins in obese women: effects of jejunoileal bypass, *Gastroenterol Clin North Am* 16:483, 1987.

632. **Gerrits EG, Ceulemans R, van Hee R, Hendrickx L, Totté E**, Contraceptive treatment after biliopancreatic diversion needs consensus, *Obes Surg* 13:378, 2003.
633. **Azziz R**, The hyperandrogenic-insulin-resistant acanthosis nigricans syndrome: therapeutic response, *Fertil Steril* 61:570, 1994.
634. **Nader S, Riad-Gabriel MG, Saad M**, The effect of a desogestrel-containing oral contraceptive on glucose tolerance and leptin concentrations in hyperandrogenic women, *J Clin Endocrinol Metab* 82:3074, 1997.
635. **Pasquali R, Gambineri A, Anconetani B, Vicennati V, Colitta D, Caramelli E, Casimirri F, Morselli-Labate AM**, The natural history of the metabolic syndrome in young women with the polycystic ovary syndrome and the effect of long-term oestrogen-progestogen treatment, *Clin Endocrinol* 50:517, 1999.
636. **Klibanski A, Biller BMK, Schoenfeld DA, Herzog DB, Saxe VC**, The effects of estrogen administration on trabecular bone loss in young women with anorexia nervosa, *J Clin Endocrinol Metab* 80:898, 1995.
637. **Drinkwater BL, Bruemmer B, Chesnut CH III**, Menstrual history as a determinant of current bone density in young athletes, *JAMA* 263:545, 1990.
638. **Jonnavithula S, Warren MP, Fox RP, Lazaro MI**, Bone density is compromised in amenorrheic women despite return of menses: a 2-year study, *Obstet Gynecol* 81:669, 1993.
639. **Grimmer SF, Back DJ, Orme ML, Cowie A, Gilmore I, Tjia J**, The bioavailability of ethinylloestradiol and levonorgestrel in patients with an ileostomy, *Contraception* 33:51, 1986.
640. **Nilsson LO, Victor A, Kral JG, Johansson ED, Kock NG**, Absorption of an oral contraceptive gestagen in ulcerative colitis before and after proctocolectomy and construction of a continent ileostomy, *Contraception* 31:195, 1985.
641. **Sandler RS, Wurzelmann JI, Lyles CM**, Oral contraceptive use and the risk of inflammatory bowel disease, *Epidemiology* 3:374, 1992.
642. **Timmer A, Sutherland LR, Martin F**, Oral contraceptive use and smoking are risk factors for relapse in Crohn's disease. The Canadian Mesalamine for Remission of Crohn's Disease Study Group, *Gastroenterology* 114:1143, 1998.
643. **Katschinski B, Fingerie D, Scherbaum B, Goebell H**, Oral contraceptive use and cigarette smoking in Crohn's disease, *Dig Dis Sci* 38:1596, 1993.
644. **Lashner BA, Kane SV, Hanauer SB**, Lack of association between oral contraceptive use and Crohn's disease: a community-based matched case-control study, *Gastroenterology* 97:1442, 1989.
645. **Cosnes J, Carbonnel F, Carrat F, Beaugier L, Gendre JP**, Oral contraceptive use and the clinical course of Crohn's disease: a prospective cohort study, *Gut* 45:218, 1999.
646. **Pietrzak B, Bobrowska K, Jabiry-Zieniewicz Z, Kaminski P, Wielgos M, Pazik J, Durlik M**, Oral and transdermal hormonal contraception in women after kidney transplantation, *Transplant Proc* 39:2759, 2007.
647. **Jabiry-Zieniewicz Z, Bobrowska K, Kaminski P, Wielgos M, Zieniewicz K, Krawczyk M**, Low-dose hormonal contraception after liver transplantation, *Transplant Proc* 39:1530, 2007.
648. **Coutinho EM, de Souza JC, da Silva AR, de Acosta OM, Flores JG, Gu ZP, Ladipo OA, Adekunle AO, Otolorin EO, Shaaban MM, Abul Oyoom M, et al.**, Comparative study on the efficacy and acceptability of two contraceptive pills administered by the vaginal route: an international multicenter clinical trial, *Clin Pharmacol Ther* 53:65, 1993.
649. **Ziaei S, Rajaei L, Faghihzadeh S, Lamyian M**, Comparative study and evaluation of side effects of low-dose contraceptive pills administered by the oral and vaginal route, *Contraception* 65:329, 2002.
650. **Bryner RW, Toffle RC, Ullrich IH, Yeater RA**, Effect of low dose oral contraceptives on exercise performance, *Br J Sports Med* 30:36, 1996.
651. **Redman LM, Scroop GC, Westlander G, Norman RJ**, Effect of a synthetic progestin on the exercise status of sedentary young women, *J Clin Endocrinol Metab* 90:3830, 2005.
652. **Thompson HS, Hyatt JP, De Souza MJ, Clarkson PM**, The effects of oral contraceptives on delayed onset muscle soreness following exercise, *Contraception* 56:59, 1997.
653. **Brynhildsen J, Lennartsson H, Klemetz M, Dahlquist P, Hedin B, Hammar M**, Oral contraceptive use among female elite athletes and age-matched controls and its relation to low back pain, *Acta Obstet Gynecol Scand* 76:873, 1997.

654. **Milsom I, Sundell G, Andersch B**, The influence of different combined oral contraceptives on the prevalence and severity of dysmenorrhea, *Contraception* 42:497, 1990.
655. **Larsson G, Milsom I, Lindstedt G, Rybo G**, The influence of a low-dose combined oral contraceptive on menstrual blood loss and iron status, *Contraception* 46:327, 1992.
656. **Davis A, Goodwin A, Lippman J, Olson W, Kafrisen M**, Triphasic norgestimate-ethinyl estradiol for treating dysfunctional uterine bleeding, *Obstet Gynecol* 96:913, 2000.
657. **Vessey MP, Villard-Mackintosh L, Painter R**, Epidemiology of endometriosis in women attending family-planning clinics, *Br Med J* 306:182, 1993.
658. **Parazzini F, Ferraroni M, Bocciolone L, Tozzi L, Rubessa S, La Vecchia C**, Contraceptive methods and risk of pelvic endometriosis, *Contraception* 49:47, 1994.
659. **Sangi-Haghpeykar H, Poindexter AN III**, Epidemiology of endometriosis among parous women, *Obstet Gynecol* 85:983, 1995.
660. **Harada T, Momoeda M, Taketani Y, Hoshiai H, Terakawa N**, Low-dose oral contraceptive pill for dysmenorrhea associated with endometriosis: a placebo-controlled, double-blind, randomized trial, *Fertil Steril* 90:1583, 2008.
661. **Davis AR, Westhoff C, O'Connell K, Gallagher N**, Oral contraceptives for dysmenorrhea in adolescent girls: a randomized trial, *Obstet Gynecol* 106: 97, 2005.
662. **Vercellini P, Frontino G, De Giorgi O, Pietropaolo G, Pasin R, Crosignani PG**, Continuous use of an oral contraceptive for endometriosis-associated recurrent dysmenorrhea that does not respond to a cyclic pill regimen, *Fertil Steril* 80:560, 2003.
663. **Seracchioli R, Mabrouk M, Frascà C, Manuzzi L, Montanari G, Keramyda A, Venturoli S**, Long-term cyclic and continuous oral contraceptive therapy and endometrioma recurrence: a randomized controlled trial, *Fertil Steril* 93:52, 2010.
664. **Modugno F, Ness RB, Allen GO, Schildkraut JM, Davis FG, Goodman MT**, Oral contraceptive use, reproductive history, and risk of epithelial ovarian cancer in women with and without endometriosis, *Am J Obstet Gynecol* 191: 733, 2004.
665. **Enzelsberger H, Metka M, Heytmanek G, Schurz B, Kurz C, Kusztrich M**, Influence of oral contraceptive use on bone density in climacteric women, *Maturitas* 9:375, 1988.
666. **Lindsay R, Tohme J, Kandars B**, The effect of oral contraceptive use on vertebral bone mass in pre- and post-menopausal women, *Contraception* 34:333, 1986.
667. **Enzelberger H, Metka M, Heytmanek G, Schurz B, Kurz C, Kusztrich M**, Influence of oral contraceptive use on bone density in climacteric women, *Maturitas* 9:375, 1988.
668. **Kleerekoper M, Brienza RS, Schultz LR, Johnson CC**, Oral contraceptive use may protect against low bone mass, *Arch Intern Med* 151:1971, 1991.
669. **Kritz-Silverstein D, Barrett-Connor E**, Bone mineral density in postmenopausal women as determined by prior oral contraceptive use, *Am J Public Health* 83:100, 1993.
670. **Tuppurainen M, Kröger H, Saarikoski S, Honkanen R, Alhava E**, The effect of previous oral contraceptive use on bone mineral density in perimenopausal women, *Osteoporos Int* 4:93, 1994.
671. **Gambacciani M, Spinetti A, Taponeco F, Cappagli B, Piaggese L, Fioretti P**, Longitudinal evaluation of perimenopausal vertebral bone loss: effects of a low-dose oral contraceptive preparation on bone mineral density and metabolism, *Obstet Gynecol* 83:392, 1994.
672. **Pasco JA, Kotowicz MA, Henry MJ, Panahi S, Seeman E, Nicholson GC**, Oral contraceptives and bone mineral density: a population-based study, *Am J Obstet Gynecol* 182:265, 2000.
673. **Mais V, Fruzzetti F, Aiossa S, Paoletti AM, Guerriero S, Melis GB**, Bone metabolism in young women taking a monophasic pill containing 20 mg ethinylestradiol, *Contraception* 48:445, 1993.
674. **Polatti F, Perotti F, Filippa N, Gallina D, Nappi RE**, Bone mass and long-term monophasic oral contraceptive treatment in young women, *Contraception* 51:221, 1995.
675. **Hartard M, Bottermann P, Bartenstein P, Jeschke D, Schwaiger M**, Effects on bone mineral density of low-dosed oral contraceptives compared to and combined with physical activity, *Contraception* 55:87, 1997.
676. **Mallmin H, Ljunghall S, Persson I, Bergstrom R**, Risk factors for fractures of the distal forearm: a

- population-based case-control study, *Osteoporos Int* 4:97, 1994.
677. **Johansson C, Mellström D**, An earlier fracture as a risk factor for new fracture and its association with smoking and menopausal age in women, *Maturitas* 24:97, 1996.
678. **O'Neill TW, Marsden D, Adams JE, Silman AJ**, Risk factors, falls, and fracture of the distal forearm in Manchester, UK, *J Epidemiol Community Health* 50:288, 1996.
679. **O'Neill TW, Silman AJ, Naves Diaz M, Cooper C, Kanis J, Felsenberg D**, Influence of hormonal and reproductive factors on the risk of vertebral deformity in European women, *Osteoporos Int* 7:72, 1997.
680. **Cooper C, Hannaford P, Croft P, Kay CR**, Oral contraceptive pill use and fractures in women: a prospective study, *Bone* 14:41, 1993.
681. **Vessey M, Mant J, Painter R**, Oral contraception and other factors in relation to hospital referral for fracture. Findings in a large cohort study, *Contraception* 57:231, 1998.
682. **Michaëlsson K, Baron JA, Farahmand BY, Persson I, Ljunghall S**, Oral contraceptive use and risk of hip fracture: a case-control study, *Lancet* 353:1481, 1999.
683. **Hazes JMW, Dijkmans BAC, Vandenbroucke JP, De Vries RRP, Cats A**, Reduction of the risk of rheumatoid arthritis among women who take oral contraceptives, *Arthritis Rheum* 33:173, 1990.
684. **Spector TD, Hochberg MC**, The protective effect of the oral contraceptive pill on rheumatoid arthritis: an overview of the analytical epidemiological studies using meta-analysis, *J Clin Epidemiol* 43:1221, 1990.
685. **Pladevall-Vila M, Delclos GL, Varas C, Guyer H, Brugués-Tarradellas J, Anglada-Arisa A**, Controversy of oral contraceptives and risk of rheumatoid arthritis: meta-analysis of conflicting studies and review of conflicting meta-analyses with special emphasis on analysis of heterogeneity, *Am J Epidemiol* 144:1, 1996.
686. **Drossaers-Bakker KW, Zwiderman AH, van Zeben D, Breedveld FC, Hazes JM**, Pregnancy and oral contraceptive use do not significantly influence outcome in long term rheumatoid arthritis, *Ann Rheum Dis* 61:405, 2002.
687. **van der Vange N, Blankenstein MA, Kloosterboer HJ, Haspels AA, Thijssen JHH**, Effects of seven low-dose combined oral contraceptives on sex hormone binding globulin, corticosteroid binding globulin, total and free testosterone, *Contraception* 41:345, 1990.
688. **Coenen CMH, Thomas CMG, Borm GF, Rolland R**, Changes in androgens during treatment with four low-dose contraceptives, *Contraception* 53:171, 1996.
689. **Palatsi R, Hirvensalo E, Liukko P, Malmiharju T, Mattila L, Riihiluoma P, Ylöstalo P**, Serum total and unbound testosterone and sex hormone binding globulin (SHBG) in female acne patients treated with two different oral contraceptives, *Acta Derm Venereol* 64:517, 1984.
690. **Steinkampf MP, Hammond KR, Blackwell RE**, Hormonal treatment of functional ovarian cysts: a randomized, prospective study, *Fertil Steril* 54:775, 1990.
691. **Ben-Ami M, Geslevich Y, Battino S, Matilsky M, Shalev E**, Management of functional ovarian cysts after induction of ovulation. A randomized prospective study, *Acta Obstet Gynecol Scand* 72:396, 1993.
692. **MacKenna A, Fabres C, Alam V, Morales V**, Clinical management of functional ovarian cysts: a prospective and randomized study, *Hum Reprod* 15:2567, 2000.
693. **Turan C, Zorlu CG, Ugur M, Ozcan T, Kaleli B, Gokmen O**, Expectant management of functional ovarian cysts: an alternative to hormonal therapy, *Int J Gynaecol Obstet* 47:257, 1994.
694. **Nezhat CH, Nezhat F, Borhan S, Seidman DS, Nezhat CR**, Is hormonal treatment efficacious in the management of ovarian cysts in women with histories of endometriosis?, *Hum Reprod* 11:874, 1996.
695. **Rosenberg MJ, Waugh MS, Meehan TE**, Use and misuse of oral contraceptives: risk indicators for poor pill taking and discontinuation, *Contraception* 51: 283, 1995.
696. **Villegas-Salas E, Ponce de León R, Juárez-Perez MA, Grubb GS**, Effect of vitamin B6 on the side effects of a low-dose combined oral contraceptive, *Contraception* 55:245, 1997.
697. **Peterson LS, Oakley D, Potter LS, Darroch JE**, Women's efforts to prevent pregnancy: consistency of oral contraceptive use, *Fam Plann Perspect* 30:19, 1998.
698. **Chi I**, The safety and efficacy issues of progestin-only oral contraceptives — an epidemiologic perspective, *Contraception* 47:1, 1993.

699. **McCann MF, Potter LS**, Progestin-only oral contraception: a comprehensive review, *Contraception* 50(Suppl 1):S9, 1994.
700. **Moghissi KS, Marks C**, Effects of microdose progestogens on endogenous gonadotrophic and steroid hormones, cervical mucus properties, vaginal cytology and endometrium, *Fertil Steril* 22:424, 1971.
701. **Moghissi KS, Syner FN, McBride LC**, Contraceptive mechanism of microdose norethindrone, *Obstet Gynecol* 4:585, 1973.
702. **Collaborative Study Group on the Desogestrel-Containing Progestogen-Only Pill**, A double-blind study comparing the contraceptive efficacy, acceptability and safety of two progestogen-only pills containing desogestrel 75 micrograms/day or levonorgestrel 30 micrograms/day, *Eur J Contracept Reprod Health Care* 3:169, 1998.
703. **Fotherby K**, The progestogen-only pill and thrombosis, *Br J Fam Plann* 15: 83, 1989.
704. **Ball MJ, Gillmer AE**, Progestagen-only oral contraceptives: comparison of the metabolic effects of levonorgestrel and norethisterone, *Contraception* 44: 223, 1991.
705. **Trussell J, Kost K**, Contraceptive failure in the United States: a critical review of the literature, *Stud Fam Plann* 18:237, 1987.
706. **Vessey MP, Lawless M, Yeates D, McPherson K**, Progestogen-only contraception: findings in a large prospective study with special reference to effectiveness, *Br J Fam Plann* 10:117, 1985.
707. **Bisset AM, Dingwall-Fordyce I, Hamilton MJK**, The efficacy of the progestogen-only pill as a contraceptive method, *Br J Fam Plann* 16:84, 1990.
708. **Broome M, Fotherby K**, Clinical experience with the progestogen-only pill, *Contraception* 42:489, 1990.
709. **Li R, Luo X, Archer DF, Chegini N**, Doxycycline alters the expression of matrix metalloproteases in the endometrial cells exposed to ovarian steroids and pro-inflammatory cytokine, *J Reprod Immunol* 73:118, 2007.
710. **Tayob Y, Adams J, Jacobs HS, Guillebaud J**, Ultrasound demonstration of increased frequency of functional ovarian cysts in women using progestogen-only oral contraception, *Br J Obstet Gynaecol* 92:1003, 1985.
711. **Pakarinen P, Lahteenmaki P, Rutanen EM**, The effect of intrauterine and oral levonorgestrel administration on serum concentrations of sex hormone-binding globulin, insulin and insulin-like growth factor binding protein-1, *Acta Obstet Gynecol Scand* 78:423, 1999.
712. **Dunson TR, McLaurin VL, Grubb GS, Rosman AW**, A multicenter clinical trial of a progestin-only oral contraceptive in lactating women, *Contraception* 47:23, 1993.
713. **Mintz G, Gutierrez G, Deleze M, Rodriguez E**, Contraception with progestogens in systemic lupus erythematosus, *Contraception* 30:29, 1984.
714. **Winkler UH, Howie H, Bühler K, Korver T, Geurts TBP, Coelingh Bennink HJT**, A randomized controlled double-blind study of the effects on hemostasis of two progestogen-only pills containing 75 mg desogestrel or 30 mg levonorgestrel, *Contraception* 57:385, 1998.
715. **Weiderpass E, Adami HO, Baron JA, Magnusson C, Bergstrom R, Lindgren A, Correia N, Persson I**, Risk of endometrial cancer following estrogen replacement with and without progestins, *J Natl Cancer Inst* 91:1131, 1999.
716. **Burton R, Savage W, Reader F**, The “morning after pill.” Is this the wrong name for it?, *Br J Fam Plann* 15:119, 1990.
717. **Young L, McCowan LM, Roberts HE, Farquhar CM**, Emergency contraception—why women don’t use it, *N Z Med J* 108:145, 1995.
718. **Harper CC, Ellerton CE**, The emergency contraceptive pill: a survey of knowledge and attitudes among students at Princeton, *Am J Obstet Gynecol* 173:1438, 1995.
719. **Hu X, Cheng L, Hua X, Glasier A**, Advanced provision of emergency contraception to postnatal women in China makes no difference in abortion rates: a randomized controlled trial, *Contraception* 72:111, 2005.
720. **Raymond EG, Stewart F, Weaver M, Monteith C, Van Der Pol B**, Impact of increased access to emergency contraceptive pills: a randomized controlled trial, *Obstet Gynecol* 108:1098, 2006.
721. **Rocca CH, Schwartz EB, Stewart FH, Darney PD, Raine TR, Harper CC**, Beyond access: acceptability, use, and nonuse of emergency contraception among young women, *Am J Obstet Gynecol* 196:29, 2007.

722. **Sambol NC, Harper CC, Kim L, Liu CY, Darney P, Raine TR**, Pharmacokinetics of single-dose levonorgestrel in adolescents, *Contraception* 74:104, 2006.
723. **Delbanco SF, Mauldon J, Smith MD**, Little knowledge and limited practice: emergency contraceptive pills, the public, and the obstetrician-gynecologist, *Obstet Gynecol* 89:1006, 1997.
724. **Trussell J, Stewart F, Guest F, Hatcher RA**, Emergency contraceptive pills: a simple proposal to reduce unintended pregnancies, *Fam Plann Perspect* 24:269, 1992.
725. **Harvey SM, Beckman LJ, Sherman C, Petitti D**, Women's experience and satisfaction with emergency contraception, *Fam Plann Perspect* 31:237, 1999.
726. **Raine T, Harper C, Rocca C, Fisher R, Darney PD**, Direct access to emergency contraception through pharmacies and effect on unintended pregnancy and STIs: a randomized controlled trial, *JAMA* 193:54, 2005.
727. **Morris JM, van Wageningen G**, Compounds interfering with ovum implantation and development. III. The role of estrogens, *Am J Obstet Gynecol* 96:804, 1966.
728. **Yuzpe AA, Smith RP, Rademaker AW**, A multicenter clinical investigation employing ethinyl estradiol combined with DL-norgestrel as a postcoital contraceptive agent, *Fertil Steril* 37:508, 1982.
729. **Ho PC, Kwan MSW**, A prospective randomized comparison of levonorgestrel with the Yuzpe regimen in post-coital contraception, *Hum Reprod* 8:389, 1993.
730. **Task Force on Postovulatory Methods of Fertility Regulation**, Randomised controlled trial of levonorgestrel versus the Yuzpe regimen of combined oral contraceptives for emergency contraception, *Lancet* 352:428, 1998.
731. **von Hertzen H, Piaggio G, Ding J, Chen J, Song S, Bartfai G, Ng E, Gemzell-Danielsson K, Oyunbileg A, Wu S, Cheng W, Ludicke F, Pretnar-Darovec A, Kirkman R, Mittal S, Khomassuridze A, Apter D, Peregoudov A; WHO Research Group on Post-Ovulatory Methods of Fertility Regulation**, Low dose mifepristone and two regimens of levonorgestrel for emergency contraception: a WHO multicentre randomised trial, *Lancet* 360:1803, 2002.
732. **Arowojolu AO, Okewole IA, Adekunle AO**, Comparative evaluation of the effectiveness and safety of two regimens of levonorgestrel for emergency contraception in Nigerians, *Contraception* 66:269, 2002.
733. **Glasier A, Baird D**, The effects of self-administering emergency contraception, *N Engl J Med* 339:1, 1998.
734. **Raine T, Harper C, Leon K, Darney P**, Emergency contraception: advance provision in a young, high-risk clinic population, *Obstet Gynecol* 96:1, 2000.
735. **Jackson RD, Bimla Schwarz E, Freedman L, Darney P**, Advance supply of emergency contraception: effect on use and usual contraception—a randomized trial, *Obstet Gynecol* 102:8, 2003.
736. **Gainer E, Blum J, Toverud E-L, Portugal N, Tyden T, Nesheim B-I, Larsson M, Vilar D, Nymoer P, Aneblom G, Lutwick A, Winikoff B**, Bringing emergency contraception over the counter: experiences of nonprescription users in France, Norway, Sweden and Portugal, *Contraception* 68:117, 2003.
737. **Young DC, Wiehle RD, Joshi SG, Poindexter AN III**, Emergency contraception alters progesterone-associated endometrial protein in serum and uterine luminal fluid, *Obstet Gynecol* 84:266, 1994.
738. **Swahn ML, Westlund P, Johannisson E, Bygdeman M**, Effect of postcoital contraceptive methods on the endometrium and the menstrual cycle, *Acta Obstet Gynecol Scand* 75:738, 1996.
739. **Trussell J, Raymond EG**, Statistical evidence about the mechanism of action of the Yuzpe regimen of emergency contraception, *Obstet Gynecol* 93:872, 1999.
740. **Marions L, Hultenby K, Lindell I, Sun X, Stabi B, Gemzell Danielsson K**, Emergency contraception with mifepristone and levonorgestrel: mechanism of action, *Obstet Gynecol* 100:65, 2002.
741. **Croxatto HB, Fuentealba B, Brache V, Salvatierra AM, Alvarez G, Massai R, Cochon L, Faundes A**, Effects of the Yuzpe regimen, given during the follicular phase, on ovarian function, *Contraception* 65:121, 2002.
742. **Novikova N, Weisberg E, Stanczyk FZ, Croxatto HB, Fraser IS**, Effectiveness of levonorgestrel emergency contraception given before or after ovulation—a pilot study, *Contraception* 75:112, 2007.
743. **Lalitkumar PG, Lalitkumar S, Meng CX, Stavreus-Evers A, Hambiliki F, Bentin-Ley U, Gemzell-Danielsson K**, Mifepristone, but not levonorgestrel, inhibits human blastocyst attachment to an in vitro endometrial three-dimensional cell culture model, *Hum Reprod* 22:3031, 2007.



744. **Meng CX, Cheng LN, Lalitkumar PG, Zhang L, Zhang HJ, Gemzell-Danielsson K**, Expressions of steroid receptors and Ki67 in first-trimester decidua and chorionic villi exposed to levonorgestrel used for emergency contraception, *Fertil Steril* 91(Suppl 4):1420, 2009.
745. **Ortiz ME, Ortiz RE, Fuentes MA, Parraguez VH, Croxatto HB**, Post-coital administration of levonorgestrel does not interfere with post-fertilization events in the new-world monkey *Cebus apella*, *Hum Reprod* 19:1352, 2004.
746. **Muller AL, Lladós CM, Croxatto HB**, Postcoital treatment with levonorgestrel does not disrupt postfertilization events in the rat, *Contraception* 67:415, 2003.
747. **Trussell J, Ellertson C, Dorflinger L**, Effectiveness of the Yuzpe regimen of emergency contraception by cycle day of intercourse: implications for mechanism of action, *Contraception* 67:167, 2003.
748. **Okewole IA, Arowojolu AO, Odusoga OL, Oloyede OA, Adeleye OA, Salu J, Dada OA**, Effect of single administration of levonorgestrel on the menstrual cycle, *Contraception* 75:372, 2007.
749. **Fasoli M, Parazzini F, Cecchetti G, La Vecchia C**, Post-coital contraception: an overview of published studies, *Contraception* 39:459, 1989.
750. **Haspels AA**, Emergency contraception: a review, *Contraception* 50:101, 1994.
751. **Glasier A**, Emergency postcoital contraception, *N Engl J Med* 337:1058, 1997.
752. **Wilcox AJ, Weinberg CR, Baird DD**, Timing of sexual intercourse in relation to ovulation. Effects on the probability of conception, survival of the pregnancy, and sex of the baby. *N Engl J Med* 333:1517, 1995.
753. **Trussell J, Ellertson C, Stewart F**, The effectiveness of the Yuzpe regimen of emergency contraception, *Fam Plann Perspect* 28:58, 1996.
754. **Trussell J, Rodríguez G, Ellertson C**, New estimates of the effectiveness of the Yuzpe regimen of emergency contraception, *Contraception* 57:363, 1998.
755. **Trussell J, Rodríguez C, Ellertson C**, Updated estimates of the effectiveness of the Yuzpe regimen of emergency contraception, *Contraception* 59: 147, 1999.
756. **Trussell J, Ellertson C, Rodríguez G**, The Yuzpe regimen of emergency contraception: how long after the morning after?, *Obstet Gynecol* 88:150, 1996.
757. **Rodríguez I, Grou F, Joly J**, Effectiveness of emergency contraceptive pills between 72 and 120 hours after unprotected sexual intercourse, *Am J Obstet Gynecol* 184:531, 2001.
758. **Piaggio G, von Hertzen H, Grimes DA, Van Look PFA; on behalf of the Task Force on Postovulatory Methods of Fertility Regulation**, Timing of emergency contraception with levonorgestrel or the Yuzpe regimen, *Lancet* 353:721, 1999.
759. **Vasilakis C, Jick SS, Jick H**, The risk of venous thromboembolism in users of postcoital contraceptive pills, *Contraception* 59:79, 1999.
760. **Webb A, Taberner D**, Clotting factors after emergency contraception, *Adv Contracept* 9:75, 1993.
761. **Ellertson C, Webb A, Blanchard K, Bigrigg A, Haskell S, Shochet T, Trussell J**, Modifying the Yuzpe regimen of emergency contraception: a multicenter randomized controlled trial, *Obstet Gynecol* 101:1160, 2003.
762. **Webb AMC, Russell J, Elstein M**, Comparison of Yuzpe regimen, danazol, and mifepristone (RU486) in oral postcoital contraception, *Br Med J* 305:927, 1992.
763. **Glasier A, Thong KJ, Dewar M, Mackie M, Baird DT**, Mifepristone (RU 486) compared with high-dose estrogen and progestogen for emergency postcoital contraception, *N Engl J Med* 327:1041, 1992.
764. **Task Force on Postovulatory Methods of Fertility Regulation**, Comparison of three single doses of mifepristone as emergency contraception: a randomised trial, *Lancet* 353:697, 1999.
765. **Xiao BL, von Hertzen H, Zhao H, Piaggio G**, A randomized double-blind comparison of two single doses of mifepristone for emergency contraception, *Hum Reprod* 17:3084, 2002.
766. **Hamoda H, Ashok PW, Stalder C, Flett GM, Kennedy E, Templeton A**, A randomized trial of mifepristone (10 mg) and levonorgestrel for emergency contraception, *Obstet Gynecol* 104:1307, 2004.
767. **Creinin MD, Schlaff W, Archer DF, Wan L, Frezieres R, Thomas M, Rosenberg M, Higgins J**, Progesterone receptor modulator for emergency contraception: a randomized controlled trial, *Obstet Gynecol* 108:1089, 2006.
768. **Glasier AF, Cameron ST, Fine PM, Logan SJS, Casale W, Van Horn J, Sogor L, Blithe DL, Scherrer**

- B, Mathe H, Jaspart A, Ulmann A, Gainer E**, Ulipristal acetate versus levonorgestrel for emergency contraception: a randomised non-inferiority trial and meta-analysis, *Lancet* 375:555, 2010.
769. **Henshaw SK, Kost K**, Trends in the Characteristics of Women Obtaining Abortions, 1974 to 2004, Guttmacher Institute, New York, 2008.
770. **Paul C, Skegg DC, Spears GF**, Oral contraceptive use and risk of breast cancer in older women, *Cancer Causes Control* 6:485, 1995.
771. **Kirkman RJE, Pedersen JH, Fioretti P, Roberts HE**, Clinical comparison of two low-dose oral contraceptives, Minulet and Mercilon, in women over 30 years of age, *Contraception* 49:33, 1994.
772. **Fioretti P, Fruzzetti F, Navalesi R, Ricci C, Moccoli R, Cerri FM, Orlandi MC, Melis GB**, Clinical and metabolic study of a new pill containing 20 mcg ethinylestradiol plus 0.150 mg desogestrel, *Contraception* 35:229, 1987.
773. **Steffensen K**, Evaluation of an oral contraceptive containing 0.150 mg desogestrel and 0.020 mg ethinylestradiol in women aged 30 years or older, *Acta Obstet Gynecol Scand Suppl* 144:23, 1987.
774. **Melis GB, Fruzzetti F, Nicoletti I, Ricci C, Lammers P, Atsma WJ, Fioretti P**, A comparative study on the effects of a monophasic pill containing desogestrel plus 20 mg ethinylestradiol, a triphasic combination containing levonorgestrel and a monophasic combination containing gestodene on coagulatory factors, *Contraception* 43:23, 1991.
775. **Gordon EM, Williams SR, Frenchek B, Mazur CH, Speroff L**, Dose-dependent effects of postmenopausal estrogen/progestin on antithrombin III and factor XII, *J Lab Clin Med* 111:52, 1988.
776. **Poulter NR, Chang CL, Farley TMM, Meirik O**, Risk of cardiovascular diseases associated with oral progestagen preparations with therapeutic indications, *Lancet* 354:1610, 1999.
777. **Vasilakis C, Jick H, del Mar Melero-Montes M**, Risk of idiopathic venous thromboembolism in users of progestagens alone, *Lancet* 354:1610, 1999.
778. **Gebbie AE, Glasier A, Sweeting V**, Incidence of ovulation in perimenopausal women before and during hormone replacement therapy, *Contraception* 52:221, 1995.
779. **Casper RF, Dodin S, Reid RL; Study Investigators**, The effect of 20 mg ethinyl estradiol/1 mg norethindrone acetate (Minestrin), a low-dose oral contraceptive, on vaginal bleeding patterns, hot flashes, and quality of life in symptomatic perimenopausal women, *Menopause* 4:139, 1997.
780. **Castracane VD, Gimpel T, Goldzieher JW**, When is it safe to switch from oral contraceptives to hormonal replacement therapy?, *Contraception* 52:371, 1995.
781. **Creinin MD**, Laboratory criteria for menopause in women using oral contraceptives, *Fertil Steril* 66:101, 1996.

## Long-Acting Methods of Contraception

The rate of unintended pregnancies and the relatively high failure rates with the typical use of hormonal and barrier methods of contraception are strong indications of a need for long-acting contraceptive methods that simplify compliance. Three effective and popular methods are available, contraceptive implants (systems with the sustained release of a progestin), depot-medroxyprogesterone acetate (Depo-Provera), and intrauterine devices (IUDs).

Injectable depot-medroxyprogesterone acetate is a long-acting (3 months) agent that has been part of the contraceptive programs of many countries for more than 30 years. This experience has demonstrated it to be safe and effective. It is not a “sustained-release” system, but its action is essentially the same. Over 35 million women worldwide use this as their primary method of contraception.<sup>1</sup>

The contraceptive implant uses either levonorgestrel or etonogestrel as the progestin. Nexplanon is currently available in the United States, replacing Implanon, and is a single rod releasing etonogestrel. The Norplant and Jadelle (formerly called Norplant-2) systems release levonorgestrel. A Chinese version is called Sinoplant II. Jadelle is approved by the U.S. Food and Drug Administration, but is not marketed, and Norplant was withdrawn from the U.S. market. In many parts of the world, Jadelle has replaced the use of Norplant; however, Norplant is still used worldwide.

Norplant consists of six capsules, and Jadelle has two rods. Like Norplant, Nexplanon and Implanon have been extensively marketed throughout the world with a good track record and high continuation rates. Contraceptive implants are approved in more than 60 countries and used by approximately five million women.<sup>1</sup>

Current intrauterine contraceptives include hormonal systems and copper systems. Hormonal systems release levonorgestrel and include the Mirena, Skyla, Kyleena, and Liletta—these release between 12 and 20 mcg of levonorgestrel a day. Copper IUDs contain between 200 and 380 mm<sup>2</sup> of copper wire. This group of IUDs is represented in the United States by the TCu-380A (the ParaGard) and in the rest of the world by the TCu-200, the TCu-220C, the Nova T, the Multiload-250, and the Multiload-375. The Sof-T is a copper IUD used only in Switzerland. More flexible and even frameless IUDs are being marketed in Europe, such as the FlexiGard, the Ombrelle-250, and the Ombrelle-380. Over 103 million woman worldwide use an IUD as their contraceptive choice.<sup>1</sup>

The long-acting progestin methods and IUDs are as effective as sterilization and more effective than oral and barrier contraception.<sup>2</sup> An important reason for this high efficacy in actual use is the nature of the delivery systems themselves, which require little effort on the part of the user. Because compliance does not require frequent resupply or instruction in use, as with oral contraception, the actual or typical use effectiveness is very close to the theoretical (lowest expected) effectiveness.

Sustained-release methods require less of the user, but they demand more of the clinician. Implants and IUDs involve minor operative procedures for placement and for discontinuation. Clinicians have a special responsibility to become skillful in these operations and to be available to women when those skills are required to terminate use. Disturbances of menstrual patterns and other side effects prompt many more questions from patients about these methods than about the use of the familiar oral and barrier contraceptives.<sup>3</sup> When women do switch to long-acting methods, there may be a higher continuation rate and a lower unintended pregnancy rate.<sup>4</sup>

# IMPLANT SYSTEMS

---

Norplant was developed by the Population Council and first approved in 1983 in Finland, where it was manufactured. It was approved in the United States in 1990, marketed in 1991, and withdrawn from the market in 2002. Norplant is a “sustained-release” system using silastic tubing permeable to steroid molecules to provide stable circulating levels of synthetic progestin over years of use. The Norplant system consists of six capsules, each measuring 34 mm in length with a 2.4 mm outer diameter and containing 36 mg crystalline levonorgestrel. The capsules are made of flexible, medical-grade silastic (polydimethylsiloxane and methylvinyl siloxane copolymer) tubing that is sealed shut with silastic medical adhesive (polydimethylsiloxane).

Jadelle was also developed by the Population Council and manufactured in Finland. It was approved in the United States in 1996, but never marketed. The thin, flexible Jadelle rods are wrapped in silastic tubing (the same material used by Norplant), 43 mm in length and 2.5 mm in diameter, thus slightly longer and thicker than Norplant.<sup>5</sup> Each rod contains 75 mg levonorgestrel for a total of 150 mg, 66 mg less than that in the six Norplant capsules. Whereas the levonorgestrel in Norplant is packed into the capsules in crystal form, the core of the Jadelle rod is a mixture of levonorgestrel and an elastic polymer (dimethylsiloxane/methylvinylsiloxane). Long-term clinical trials indicate that the performance and side effects are similar to Norplant, but removal is faster (Table 23.1).<sup>6,7</sup>

## TABLE 23.1 Norplant and Jadelle Average Release Rates

## Norplant

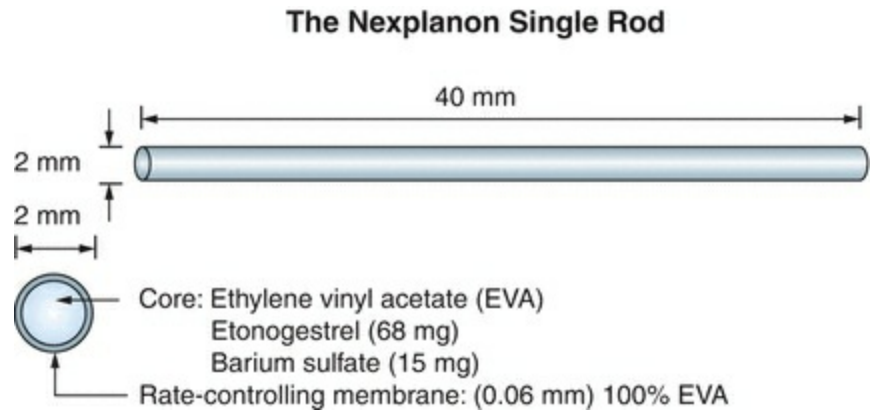
First month	85 mg levonorgestrel daily
After 1 year	35 mg
After 2 years	30 mg

## Jadelle

First month	100 mg levonorgestrel daily
After 1 year	40 mg
After 2 years	30 mg

Because the release rates with the two levonorgestrel systems are comparable, it is reasonable to conclude that clinical studies with Norplant and Jadelle should yield similar results. In the discussion that follows, the more-studied product, Norplant, is often cited, but clinicians can assume that the findings apply as well to Jadelle.

Nexplanon is a single flexible rod 4 cm long and 2 mm in diameter that contains 68 mg of 3-keto desogestrel (etonogestrel, the active metabolite of desogestrel) and 15 mg barium sulfate (for radio-opacity) dispersed in a core of ethylene vinyl acetate. There is no evidence that either ethylene vinyl acetate or silastic has toxic effects when implanted.<sup>8</sup> Randomized controlled trials showed no significant difference in etonogestrel secretion compared with the Implanon. The hormone is released at an initial rate of about 67 mg/day decreasing to 30 mg after 2 years; concentrations that inhibit ovulation are achieved within 8 hours of insertion.<sup>9,10</sup> A steady state is achieved after 4 months; after which there is a gradual decline. Nexplanon, placed subdermally with a disposable inserter, can be expected to suppress ovulation for 2.5 years and provide effective contraception for at least 3 years. Side effects are similar to those with Norplant or Jadelle, except for less bleeding and a higher rate of amenorrhea with etonogestrel implant<sup>11,12,13,14</sup> (**Figure 23.1**).



**FIGURE 23.1**

# Indications

Contraceptive implants are a good choice for women of reproductive age who are sexually active and desire long-term, continuous contraception. Implants should be considered for women who:

1. Want to delay the next pregnancy for at least 2–3 years
2. Desire a highly effective, long-term method of contraception
3. Experience serious or minor estrogen-related side effects with estrogen-progestin contraception
4. Have difficulty remembering to take pills every day, have contraindications or difficulty using IUDs, or desire a non-coitus-related method of contraception
5. Have completed their childbearing but are not yet ready to undergo permanent sterilization
6. Have a history of anemia with heavy menstrual bleeding
7. Intend to breast-feed for a year or two
8. Have chronic illnesses, in which health will be threatened by pregnancy



# **Absolute Contraindications**

Implant use is contraindicated in women who have:

- 1. Active thrombophlebitis or thromboembolic disease**
- 2. Undiagnosed genital bleeding**
- 3. Acute liver disease**
- 4. Benign or malignant liver tumors**
- 5. Known or suspected breast cancer**

# Other Medical Eligibility Criteria

Based on clinical judgment and appropriate medical management, implants **MAY BE USED** by women with a history of or current diagnosis of the following conditions:

1. Heavy cigarette smoking (15 or more daily) in women older than 35 years
2. History of ectopic pregnancy
3. Diabetes mellitus. Because multiple studies have failed to observe a significant impact on carbohydrate metabolism, implants, in our view, are particularly well suited for diabetic women.
4. Hypercholesterolemia
5. Hypertension
6. History of cardiovascular disease, including myocardial infarction, cerebral vascular accident, coronary artery disease, angina, or a previous thromboembolic event
7. Patients with artificial heart valves
8. Gallbladder disease
9. Chronic disease, such as immunocompromised patients

Implants are not contraindicated in the following situations, but other methods are preferable:

1. Severe acne
2. Severe vascular or migraine headaches
3. Severe depression
4. Concomitant use of medications that induce microsomal liver enzymes:

Carbamazepine (Tegretol)

Felbamate

Griseofulvin

Lamotrigine

Nevirapine

Oxcarbazepine

Phenobarbital

Phenytoin (Dilantin)

Primidone (Mysoline)

Rifabutin

Rifampicin (Rifampin)

St. John's wort

Topiramate

Vigabatrin

Possibly troglitazone

We do not recommend the use of implants with any of the previously listed drugs because of a likely increased risk of pregnancy due to lower blood levels of the progestin.<sup>15,16,17</sup>

## Mechanism of Action

The release rate of the contraceptive implants is determined by the total surface area and the density of the implant in which the progestin is contained. The progestin diffuses from the implant into the surrounding tissues where it is absorbed by the circulatory system and distributed systemically, avoiding an initial high level in the circulation as with oral or injected steroids. Within 8 hours after insertion of Nexplanon, plasma concentrations of etonogestrel are about 300 ng/mL, high enough to prevent ovulation.<sup>18</sup> A study of cervical mucus changes with Norplant indicates that a backup method should be used for 3 days after insertion of Norplant or Jadelle; this is not necessary when Nexplanon is inserted as directed.<sup>19,20</sup> Progestin concentrations are much more variable with Norplant and Jadelle than with the etonogestrel implants.<sup>18</sup>

The Nexplanon rod releases 60 mg of etonogestrel per 24 hours at 3 months of use. This rate declines gradually to 40–50 mg daily by 12 months and 30 mg/day by 2 years of use. The 85 mg of hormone released by Norplant or the 100 mg released by Jadelle during the first few months of use is about equivalent to the daily dose of levonorgestrel delivered by the progestin-only minipill oral contraceptive and 25–50% of the dose delivered by low-dose combined oral contraceptives. After 6 months of use, daily levonorgestrel concentrations are about 0.35 ng/mL; at 2.5 years, the levels decrease to 0.25–0.35 ng/mL. Until the 8-year mark, mean levels remain above 0.25 ng/mL.<sup>21</sup> Mean plasma concentrations below 0.2 ng/mL are associated with increased pregnancy rates for Norplant (lower levels are more likely in heavier women).

Body weight affects the circulating levels of levonorgestrel; the greater the weight of the user, the lower the levonorgestrel concentrations at any time during Norplant or Jadelle use. The greatest decrease over time occurs in women weighing more than 70 kg (154 lb), but even for heavy women, the release rate is high enough to prevent pregnancy at least as reliably as oral contraceptives. In Nexplanon users, etonogestrel concentrations are affected very little by body weight, and failure rates did not increase with increasing body weight in the small numbers of overweight women in clinical trials.<sup>22,23</sup> Although the data with overweight women are limited, it is likely that Nexplanon is a good contraceptive choice for obese women.

Levonorgestrel levels can also be affected by the circulating levels of sex hormone-binding globulin (SHBG). Levonorgestrel has a higher affinity for SHBG than does etonogestrel. In the week after Norplant or Jadelle insertion, SHBG levels decline rapidly and then return to approximately half of preinsertion levels by 1 year of use. This effect on SHBG is not uniform and may account for some of the individual variations in circulating progestin concentrations.<sup>24</sup>

Implants are highly effective contraceptives. There are three probable modes of

action, which are similar to those attributed to the contraceptive effect of the progestin-only minipills, but because daily dosing is not required, implants are more effective than oral methods:

1. The progestin suppresses, at both the hypothalamus and the pituitary, the luteinizing hormone (LH) surge necessary for ovulation. As determined by progesterone levels in many users over several years, approximately one-third of all cycles in Norplant users are ovulatory.<sup>21,25</sup> During the first 2 years of use, only about 10% of women are ovulatory, but by 5 years of use, more than 50% are. In those cycles that are ovulatory, there is a high incidence of luteal insufficiency. The etonogestrel implant inhibits ovulation throughout a 3-year period, accounting for almost all of the contraceptive effect.<sup>10</sup> However, follicular development does occur, avoiding the problem of clinically significant hypoestrogenemia, and in the last 6 months of the 3-year period, there is an occasional ovulation.<sup>18,26</sup>
2. The steady release of progestin has a prolonged effect on the cervical mucus. The mucus thickens and decreases in amount, forming a barrier to sperm penetration.<sup>20,26,27,28</sup>
3. The progestin suppresses the estradiol-induced cyclic maturation of the endometrium and eventually causes atrophy. These changes could prevent implantation should fertilization occur; however, no evidence of fertilization can be detected in Norplant users.<sup>29</sup>

# Advantages

Implants are a safe, highly effective, continuous method of contraception that requires little user effort and, unlike long-acting injectable contraception, is rapidly reversible. Because this is a progestin-only method, it can be used by women who have contraindications for the use of estrogen-containing contraceptives. The sustained release of low doses of progestin avoids the high initial dose delivered by injectables and the daily hormone surge associated with oral contraceptives. Implants are an excellent choice for a breast-feeding woman and can be inserted immediately postpartum. There are no effects on breast milk quality or quantity, and infants grow normally.<sup>30,31,32,33</sup> Another advantage of the implant method is that it allows women to plan their pregnancies precisely; return of fertility occurs within a few weeks, in contrast to the 6–18-month delay in ovulation that can follow depot-medroxyprogesterone acetate injections.<sup>22,34,35,36</sup>

The degree of efficacy of long-acting contraceptive methods is nearly equivalent to the theoretical effectiveness. In couples for whom elective abortion is unacceptable in the event of an unplanned pregnancy, the high efficacy rate is especially important. Additionally, users should be reassured that implant use has not been associated with changes in carbohydrate or lipid metabolism, coagulation, liver or kidney function, or immunoglobulin levels. Because women wanting implants may have had negative experiences with other contraceptives, it is important that the differences between this method and previous methods be explained.

Exposure of endometriosis to progestin-only contraceptive methods is an effective method to manage the pain associated with this condition. Etonogestrel implants, depot-medroxyprogesterone acetate, and the levonorgestrel-containing IUD have all been reported to reduce endometriosis pain ([Chapter 32](#)).<sup>37,38,39,40,41</sup> As discussed in the chapter on endometriosis, this disease can become resistant to progesterone action, and low concentrations of progestins provided by these devices do not always suffice to fully treat aggressive forms of the disease.

# Disadvantages

There are some disadvantages associated with the use of the implant systems. Implants cause disruption of bleeding patterns, and 11% of women may discontinue etonogestrel implants due to bleeding irregularities they find unacceptable.<sup>22</sup> Endogenous estrogen is nearly normal, and unlike the estrogen-progestin contraceptives, progestin is not regularly withdrawn to allow endometrial sloughing. Consequently, the endometrium sheds at unpredictable intervals.

The implants must be inserted and removed in a surgical procedure performed by trained personnel. Women cannot initiate or discontinue the method without the assistance of a clinician. The incidence of complicated removals is approximately 5% for Norplant or Jadelle and lower for Nexplanon, an incidence that can be best minimized by good training and careful insertion.<sup>42,43</sup> The implants can be visible under the skin. This sign of the use of contraception may be unacceptable for some women and for some partners.

Implants do not provide protection against sexually transmitted infections (STIs) such as herpes, human papillomavirus, human immunodeficiency virus (HIV), gonorrhea, or chlamydia. Although users may be less likely to use a second method because of the high contraceptive efficacy,<sup>44</sup> users at risk for STIs must use condoms as a second method to prevent infection.

Because the insertion and removal of implants require minor surgical procedures, initiation and discontinuation costs are higher than with oral contraceptives or barrier methods. The cost of implants plus fees for insertion totals an amount that may seem high to patients unless they compare it with the total cost of using other methods (including the higher risk of an unintended pregnancy).<sup>45,46,47</sup> Studies have shown that cost neutrality is achieved at 1–2 years of use. Nevertheless, short-term use is expensive compared with the relatively low initial costs of other reversible methods, and most women do not use long-acting methods for their full duration of action.

Cultural factors can influence the acceptability of menstrual changes. Some cultures restrict a woman from participating in religious activity, household activities, or sexual intercourse while menstruating. All users must be aware of the possible menstrual changes. It is important to stress that all of the menstrual changes are expected, that they do not cause or represent illness, and that most women revert back to a more normal pattern with increasing duration of use.

Insertion and removal of implants will be a new experience for most women. As with any new experience, women will approach it with varying degrees of apprehension and anxiety. In reality, most patients are able to watch in comfort as implants are inserted or removed. Women should be told that the incisions used for the procedures

are very small and heal quickly, leaving small scars that are usually difficult to see because of their location and size.

We encourage prospective users to see and touch implants. Women can be reassured that the implants will not be damaged or move if the skin above them is accidentally injured. Normal activity cannot damage or displace the implants. Most women do not notice their presence. The implants are more visible in slender women with good muscle tone. Darker-skinned users may notice further darkening of the skin directly over the implants; this resolves after removal.



# Efficacy

Contraceptive implants provide highly effective birth control. In 2-year or 3-year studies in 11 international clinical trials of 942 women using an etonogestrel implant, no pregnancies occurred.<sup>22</sup> In studies of Norplant conducted in 11 countries, totaling 12,133 woman-years of use, the pregnancy rate was 0.2 pregnancies per 100 woman-years of use.<sup>16,34</sup> All but one of the pregnancies that occurred during the Norplant evaluation were present at the time of implant insertion. If these luteal phase insertions are excluded from analysis, the 1st-year pregnancy rate was 0.01 per 100 woman-years. In adolescents, Norplant implants provide better protection against unwanted pregnancy compared with oral contraceptives and are more likely to be continued.<sup>44,48,49</sup> A recent review shows the 1-year continuation rate of implants among adolescents is 84%<sup>50</sup> (Table 23.2).

## **TABLE 23.2 Failure Rates During the 1st Year of Use, United States**

Method	Percent of Women with Pregnancy	
	Lowest Expected	Typical
No method	85%	85%
Combination pill	0.3%	8.7%
Progestin only	0.5%	3.0%
IUDs		
Levonorgestrel IUS	0.1%	0.1%
Copper T-380A	0.6%	1.0%
Implants		
Six levonorgestrel capsules (Norplant)	0.05%	0.2%
Two levonorgestrel rods (Jadelle)	0.06%	0.06%
One etonogestrel rod (Implanon)	0.01%	0.01%
Injectable		
3 months	0.3%	0.3%
1 month	0.05%	3.0%
Patch	0.3%	8.0%
Vaginal ring	0.3%	8.0%
Female sterilization	0.5%	0.7%
Male sterilization	0.1%	0.2%

Data from **Trussell J, Vaughan B**, Contraceptive failure, method-related discontinuation and resumption of use: results from the 1995 National Survey of Family Growth, *Fam Plann Perspect* 31:64, 1999; **Fu H, Darroch JE, Haas T, Ranjit N**, Contraceptive failure rates: new estimates from the 1995 National Survey of Family Growth, *Fam Plann Perspect* 31:58, 1999; **Kost K, Singh S, Vaughan B, Trussell J, Bankole A**, Estimates of contraceptive failure from the 2002 National Survey of Family Growth, *Contraception* 77:10, 2008.

**There are no weight restrictions for Norplant or Jadelle users, but heavier women (more than 70 kg) may experience slightly higher pregnancy rates in the later years of use compared with lighter women. Even in the later years, however, pregnancy rates for heavier women using Norplant are lower than with oral contraception.** The differences in pregnancy rates by weight are probably due to the dilutional effect of larger body size on the low, sustained serum levels of levonorgestrel.

The contraceptive efficacy of etonogestrel implants surpasses that of Norplant and sterilization.<sup>22</sup> Only a rare pregnancy occurs, resulting in a Pearl Index of about 0.01.<sup>26,51</sup> In over 70,000 cycles, no pregnancies were recorded because of total inhibition of ovulation until ovulations were observed in the last 6 months of the 3-year period.<sup>26,52</sup> Postmarketing surveillance of pregnancies in Australia, where nearly one-quarter of contraceptors relied on etonogestrel implants in 2004, revealed that of 218 pregnancies, only 13 could possibly have been failures of the method.<sup>53</sup> In Australia and the Netherlands, pregnancies commonly were the consequence of poor insertion technique, especially allowing the implant to fall unnoticed to the floor.

**Implants have an immediate contraceptive effect when inserted within the first 7 days of a menstrual cycle, but when insertion is after day 7, a backup method of contraception is necessary for at least 3 days.**<sup>54</sup>

# Ectopic Pregnancy

The ectopic pregnancy rate during Norplant use is 0.1–2.9 per 1,000 woman-years.<sup>55</sup> Although the risk of developing an ectopic pregnancy during the use of Norplant is low, when pregnancy does occur, ectopic pregnancy should be suspected because approximately 30% of Norplant pregnancies are ectopic. It is estimated that 2.3% of pregnancies with the etonogestrel implant in place are ectopic<sup>55</sup> (Table 23.3).

**TABLE 23.3 Ectopic Pregnancy Rates Per 1,000 Woman-Years**

Noncontraceptive users, all ages	3.0–4.5
Copper T-380 IUD	0.20
Norplant	0.28

Data from **Centers for Disease Control and Prevention**, Ectopic pregnancy—United States, 1988–1989, MMWR 41:591, 1992; **Franks AL, Beral V, Cates W Jr, Hogue CJ**, Contraception and ectopic pregnancy risk, Am J Obstet Gynecol 163:1120, 1990; **Sivin I**, International experience with Norplant and Norplant-2 contraceptives, Stud Fam Plann 19:81, 1988.; **Sivin I**, International experience with Norplant and Norplant-2 contraceptives, Stud Fam Plann 19:81, 1988.

# Menstrual Effects

Menstrual bleeding patterns are highly variable among users of implant contraception. With levonorgestrel implants, some alteration of menstrual patterns will occur during the 1st year of use in approximately 80% of users, later decreasing to about 40% and, by the 5th year, to about 33%.<sup>56,57,58,59</sup> The changes include alterations in the interval between bleeding, the duration and volume of menstrual flow, and spotting. Oligomenorrhea and amenorrhea also occur but are less common, less than 10% after the 1st year and diminishing thereafter. Studies of the endometrium in Norplant users experiencing abnormal bleeding indicate the presence of enlarged venous sinusoids (fragile vessels) and a reduction in the expression of the proteins involved in the initiation of hemostasis.<sup>60</sup> It is believed that bleeding is a consequence of rapid endometrial regression and the apparent increase in the density and tortuosity of blood vessels seen after Norplant insertion.<sup>61</sup>

Etonogestrel implants alter menstrual patterns, but amenorrhea occurs more often (21% of users in the 1st year, 30–40% after 1 year) than with Norplant.<sup>12,14</sup> A single etonogestrel rod completely suppresses ovulation for 2.5 years, and, therefore, menses do not become more regular after the first 2 years as with Norplant. After 2 years, ovulation occurs in about half of the menstrual cycles. Bleeding is lighter and less frequent among etonogestrel implant users because more profound ovarian suppression results in less follicular estrogen production and less endometrial stimulation; nevertheless, irregular bleeding continues to be a major reason for discontinuation.<sup>14</sup>

Despite an increase in the number of spotting and bleeding days over preinsertion menstrual patterns, hemoglobin concentrations rise in Norplant users because of a decrease in the average amount of menstrual blood loss.<sup>62,63,64 65</sup> Etonogestrel implants likewise are not associated with anemia.<sup>13</sup>

Implant users who can no longer tolerate prolonged bleeding will benefit from a short course of oral estrogen: conjugated estrogens, 1.25 mg, or estradiol, 2 mg, administered daily for 7 days.<sup>66</sup> Another approach is to administer an estrogen-progestin oral contraceptive for 1–3 months.<sup>67</sup>

**Although implants are very effective, pregnancy must be considered in women reporting amenorrhea who had been ovulating previously, as evidenced by regular menses prior to an episode of amenorrhea.** A sensitive urine pregnancy test should be obtained. Women who remain amenorrheic throughout their use of implants are unlikely to become pregnant.<sup>57</sup> It is important to explain to patients the mechanism of the amenorrhea: the local progestational effect causing decidualization and atrophy.

# Metabolic Effects

Exposure to the sustained, low doses of progestin delivered by the implants is not associated with significant metabolic changes. Studies of liver function,<sup>11,68,69</sup> blood coagulation,<sup>11,70,71,72</sup> immunoglobulin levels,<sup>73,74</sup> serum cortisol levels,<sup>75</sup> and blood chemistries<sup>69,73</sup> have failed to detect changes outside of normal ranges in Norplant users. No major impact on the lipoprotein profile can be demonstrated with Norplant.<sup>68,76,77</sup> Minor changes are transient, and, with prolonged duration of use, lipoproteins return to preinsertion levels. There are no clinically important effects on carbohydrate metabolism.<sup>73,78,79</sup> No effect on insulin sensitivity can be detected.<sup>80</sup> In a cohort study of 5 years' duration, no increase was observed in diabetes mellitus, depression, lupus erythematosus, and cardiovascular diseases—in fact, there was no increase in serious morbidity.<sup>81</sup> A slight increase in gallbladder disease has been noted in Norplant users.<sup>11,82</sup> This is at best just a word of caution because the association is weak and may reflect preexisting disease, and there is no apparent biologic mechanism.

**There are no significant metabolic differences when using the etonogestrel implant, as compared with the levonorgestrel implant and as compared with a nonhormonal method of contraception.**<sup>83,84,85</sup> One study showed that fasting glucose and insulin sensitivity markers may worsen in obese etonogestrel implant users.<sup>86</sup> Neither implant system has important clinical effects on the lipoprotein profile, carbohydrate metabolism, thyroid and adrenal function, liver function tests, nor the clotting mechanism.<sup>11,82,87</sup> Implant contraception is a good choice for a woman at risk for estrogen-associated thromboembolism. Because of the lower androgenic characteristic of etonogestrel, Nexplanon does not cause a decrease in the levels of SHBG.<sup>87</sup>

Measurements of bone density in young women reveal that etonogestrel implants and Norplant do not affect the teenage gain in the bone; similar gains in the bone were recorded in implant users and control subjects.<sup>88,89</sup> In older women, an increase in forearm, spine, and femur bone density has been documented after 6 and 12 months of Norplant use.<sup>90,91</sup> An international cross-sectional study reported a small loss in bone density with Norplant that was rapidly regained after discontinuation.<sup>92</sup>

# Effects on Future Fertility

Circulating levels of progestin become too low to measure within 48 hours after removal of implants. Most women resume normal ovulatory cycles during the 1st month after removal. The pregnancy rates during the 1st year after removal are comparable with those of women not using contraceptive methods and trying to become pregnant. There are no long-term effects on future fertility nor are there any effects on sex ratios, rates of ectopic pregnancy, spontaneous miscarriage, stillbirth, or congenital malformations.<sup>34,35</sup> The rate and outcome of subsequent pregnancies are not influenced by duration of use.

For women who are spacing their pregnancies, the difference between implants and depot-medroxyprogesterone acetate in the timing of the return to fertility can be critical. Implants allow precise timing of pregnancy because the return of ovulation after removal is prompt. Etonogestrel serum levels are undetectable within 1 week after removal of Nexplanon, and ovulation can be expected in the 1st month after discontinuation.<sup>9,10</sup> Depot-medroxyprogesterone acetate, on the other hand, can cause up to 18 months' delay in return to fertility. By that time, 90% of users of either method will have ovulated, but in the first several months, the difference is dramatic. By 3 months after removal, half of implant users will have ovulated, but 10 months must elapse before half of depot-medroxyprogesterone acetate users are ovulatory.

## Side Effects

The occurrence of serious side effects is very rare, no different in incidence than that observed in the general population. In addition to the menstrual changes, levonorgestrel implant users have reported the following side effects: headache, acne, weight change, mastalgia, hyperpigmentation over the implants, hirsutism, depression, mood changes, anxiety, nervousness, ovarian cyst formation, and galactorrhea.<sup>16,56,57,58</sup> Attribution of these side effects to levonorgestrel is difficult. Careful study fails to reveal a relationship between Norplant use and depressive symptoms.<sup>93</sup> Although most of these side effects are minor in nature, they can cause patients to discontinue the method. Patients often find common side effects tolerable after assurance that they do not represent a health hazard.<sup>3</sup> Many complaints respond to reassurance; others can be treated with simple therapies. The most common side effect experienced by users is headache (16% of etonogestrel implant users); approximately 20% of women who discontinue use do so because of headache.<sup>22</sup>

Stroke, thrombotic thrombocytopenic purpura, thrombocytopenia, and pseudotumor cerebri have been reported with Norplant.<sup>94</sup> However, it is by no means established that the incidence of these problems is increased, and there is little reason to suspect a cause-and-effect relationship. In the follow-up study conducted by the World Health Organization in eight countries, no significant excess of cardiovascular events or malignant disease was observed.<sup>95</sup> Similarly, studies looking at rates of adverse events in etonogestrel implants found no increased likelihood.<sup>43</sup>

## Weight Change

Women using levonorgestrel implants more frequently complain of weight gain than of weight loss, but findings are variable and most studies have not been randomized.<sup>96</sup> Assessment of weight change in contraceptive implant users is confounded by changes in exercise, diet, and aging. Although an increase in appetite can be attributed to the androgenic activity of levonorgestrel, it is unlikely that the low levels with Norplant have any clinical impact. Counseling for weight changes focuses best on dietary review and dietary changes.

A 5-year follow-up of 75 women with Norplant implants could document no increase in the body mass index (nor was there a correlation between irregular bleeding and body weight).<sup>94</sup> A similar experience has been documented with etonogestrel implants.<sup>13</sup>

## Mastalgia



Approximately 10% of etonogestrel implant users will complain of bilateral mastalgia.<sup>13,22</sup> This symptom decreases with increasing duration of implant use. In women with the Norplant, it is noted premenstrually and is associated with complaints of fluid retention.

After pregnancy has been ruled out, reassurance and therapy aimed at symptomatic relief are indicated. The most effective treatments for mastalgia are the following: danazol (200 mg/day), vitamin E (600 U/day), bromocriptine (2.5 mg/day), or tamoxifen (20 mg/day), but there are no studies of these treatments in implant users.

## **Galactorrhea**

Galactorrhea is more common among women who have had insertion of the implants on discontinuation of lactation. Pregnancy and other possible causes should be ruled out by performing a pregnancy test and a thorough breast examination. Patients can be reassured that this is a common occurrence among implant and oral contraceptive users. Decreasing the amount of breast and nipple stimulation during sexual relations might alleviate the symptom, but if amenorrhea accompanies persistent galactorrhea, a prolactin level should be obtained.

## **Acne**

Acne, with or without an increase in oil production, is the most common skin complaint among levonorgestrel implant users. The acne is caused by the direct androgenic activity of the levonorgestrel and also a decrease in SHBG levels, leading to an increase in free steroid levels (both levonorgestrel and testosterone).<sup>21</sup> This is in contrast to combined oral contraceptives that contain levonorgestrel, as the estrogen effect on SHBG (an increase) produces a decrease in unbound, free androgens. Etonogestrel implants are less commonly associated with acne because this progestin is less androgenic than levonorgestrel.<sup>13,18</sup> Common therapies for complaints of acne include dietary change, practice of good skin hygiene with the use of soaps or skin cleansers, and application of topical antibiotics (e.g., 1% clindamycin solution or gel or topical erythromycin).

## **Ovarian Cysts**

Unlike oral contraception, the low serum progestin levels maintained by levonorgestrel implants do not suppress follicle-stimulating hormone (FSH), which continues to stimulate ovarian follicle growth in most users. The LH peak during the first 2 years of use, on the other hand, is usually abolished so that these follicles do not ovulate.<sup>18</sup> However, some continue to grow and cause pain or they are palpated at the time of

pelvic examination.<sup>97</sup> Because these are simple cysts (and most regress spontaneously within 1 month of detection), they need not be laparoscopically evaluated.<sup>43</sup> Further evaluation is indicated if they became large and painful or fail to regress. Etonogestrel implants suppress follicular development more profoundly; thus, ovarian cysts are less likely than with levonorgestrel implants.

## Cancer

We can speculate on possible effects of implants based on our experience with oral contraceptives and depot-medroxyprogesterone acetate. The risk of endometrial cancer should be reduced. A study of the endometrial effects of Norplant failed to find any evidence of hyperplasia, even when levonorgestrel levels were low and endogenous estradiol production was normal.<sup>98</sup> The risk of ovarian cancer is also probably reduced, and we would expect a greater effect with Nexplanon because it more effectively suppresses ovulation. Breast and cervical cancer effects will be difficult to assess because of confounding variables as they are with oral contraception and depot-medroxyprogesterone acetate. The low progestin dose of implants, however, would be unlikely to have effects different from other hormonal contraceptives. In a very large case-control study, neither depot-medroxyprogesterone acetate nor implants were associated with an increase in the risk of breast cancer.<sup>99</sup>

# Postmarketing Surveillance Study

A large 5-year follow-up study in developing countries confirmed the low pregnancy rates associated with Norplant, 0.23 per 100 woman-years for intrauterine pregnancy and 0.03 per 100 woman-years for ectopic pregnancy.<sup>96</sup> When the women using Norplant were compared with women using nonhormonal methods of contraception and to the expected population rates, there was no excess of cancers, connective tissue diseases, or cardiovascular events. Importantly, the complaints of headache and mood disturbances (including anxiety and depression) were similar to those reported by women using oral contraceptives, although higher than for women using IUDs.

# Insertion and Removal

The usual personal and family medical history and physical examination should concentrate on factors that might contraindicate the use of the various contraceptive options. If a patient elects to use contraceptive implants, a detailed description of the method, including effectiveness, side effects, risks, benefits, as well as insertion and removal procedures, should be provided. Before insertion, the patient is asked to read and sign a written consent for the surgical placement of the implants. The consent reviews the potential complications of the procedure that include reaction to the local anesthetic, infection, expulsion of the implants, superficial phlebitis, bruising, and the possibility of a subsequent difficult removal.

Insertion can be performed at any time during the menstrual cycle as long as pregnancy can be ruled out. If the patient's last menstrual period was abnormal, if she has recently had sexual intercourse without contraception, or if there are reasons to suspect pregnancy, a sensitive urine pregnancy test is a wise precaution. Based on cervical mucus changes, a backup method need be used no more than 3 days after insertion.<sup>20</sup> Implants can be inserted immediately postpartum but certainly should be initiated no later than the 3rd postpartum week in non-breast-feeding women and the 3rd postpartum month in breast-feeding women. Acne and headache are less common in women who receive Norplant immediately postpartum, and there is no difference in postpregnancy weight loss compared with women who receive it 4–6 weeks later.<sup>100</sup>

## Key Points

- Insert anytime during the first 5 days of the menstrual cycle if hormonal contraception is not being used.
- If hormonal contraception is being used, insert anytime during the hormone-free interval. If steroid contraception is used continuously, insert at anytime.
- If progestin-only contraception is being used, insert on the same day the next progestin injection is due or an implant or IUD is removed. With progestin-only oral contraception, insertion can be performed anytime.
- Insert anytime within the first 5 days after an abortion or before the 4th postpartum week in non-breast-feeding women.
- Insert before the 4th postpartum month in breast-feeding women.
- An implant can be inserted immediately postpartum.
- No backup method is necessary if timing of insertion follows the above suggestions. If insertion occurs at other times, backup contraception is necessary for at least 3 days after insertion.

---

Patients should be questioned about allergies to local anesthetics, antiseptic solutions, and tape. A discussion about the technique of insertion and anticipated sensations is an important part of preparing the patient for the experience. All patients approach insertion with some degree of apprehension that can be decreased by detailed explanations and preparation.<sup>101,102</sup>

Selection of the site for placement of implants is based on both functional and esthetic factors. Various sites (the upper leg, forearm, and upper arm) have been used in clinical trials. The nondominant, upper, inner arm is the best site. This area is easily accessible to the clinician with minimal exposure of the patient. It is well protected during most normal activities. It is not highly visible, and migration of the implants from this site has not been documented. The site of placement does not affect circulating progestin levels. Careful implant insertion is the key to trouble-free removal.

The etonogestrel implant offers important insertion advantages compared with Norplant.<sup>103</sup> The single-rod system simplifies and shortens both insertion and removal. In addition, a preloaded applicator is provided that facilitates placement. If necessary, Nexplanon can usually be visualized by ultrasonography.<sup>104</sup> However, if a nonpalpable rod is not visible on ultrasonography, definitive localization can be achieved with x-ray.<sup>9</sup> Removal of the etonogestrel rod uses the “fingers alone” technique with a 2-mm incision.<sup>105</sup> Insertion complications (mainly deep insertions) are rare, and removal complications (difficulty finding the implant or a broken implant) occur at a far greater lower frequency compared with Norplant.<sup>103</sup>

## Insertion Technique

Insertion is carried out under local anesthesia in the office or clinic by someone, usually a physician or nurse practitioner, trained in the technique described here.<sup>106,107</sup> The procedure takes 5–10 minutes for a six-implant system and 2–3 minutes for a single implant<sup>108</sup> (Table 23.4, Figure 23.2).

### **TABLE 23.4 Required Equipment for Nexplanon Insertion**

---

2.5-mL syringe

---

0.5-inch, 25-gauge needle for injecting the anesthetic

---

1% chlorprocaine or lidocaine without epinephrine

---

Antiseptic solution

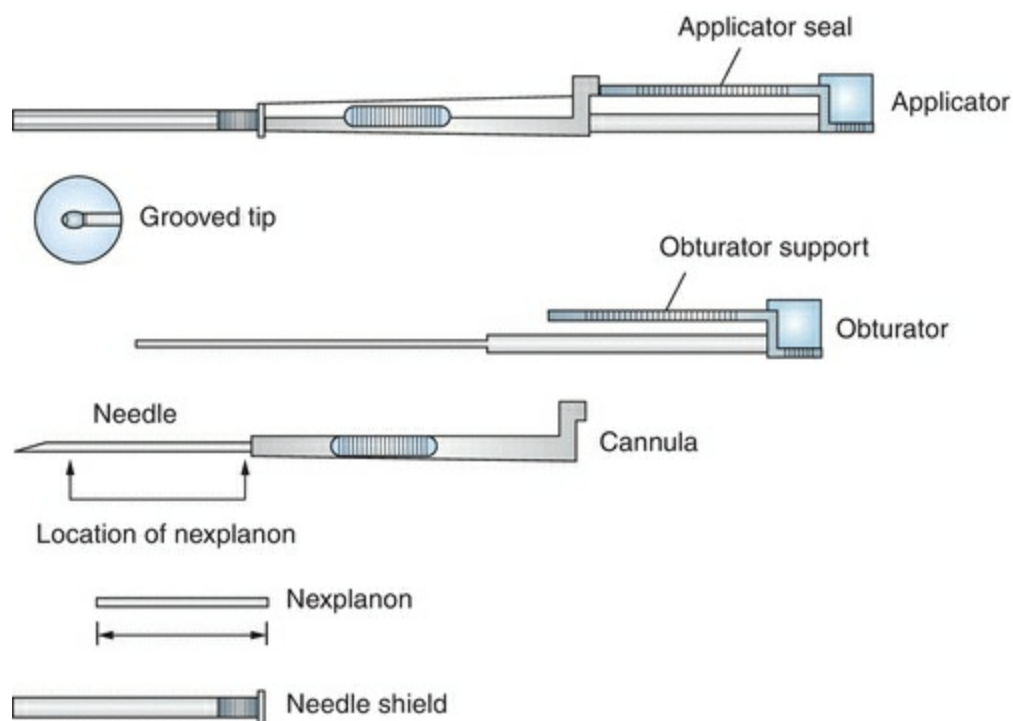
---

Adhesive strip for puncture closures

---

Elastic pressure bandage

---



**FIGURE 23.2**

## Positioning the Patient

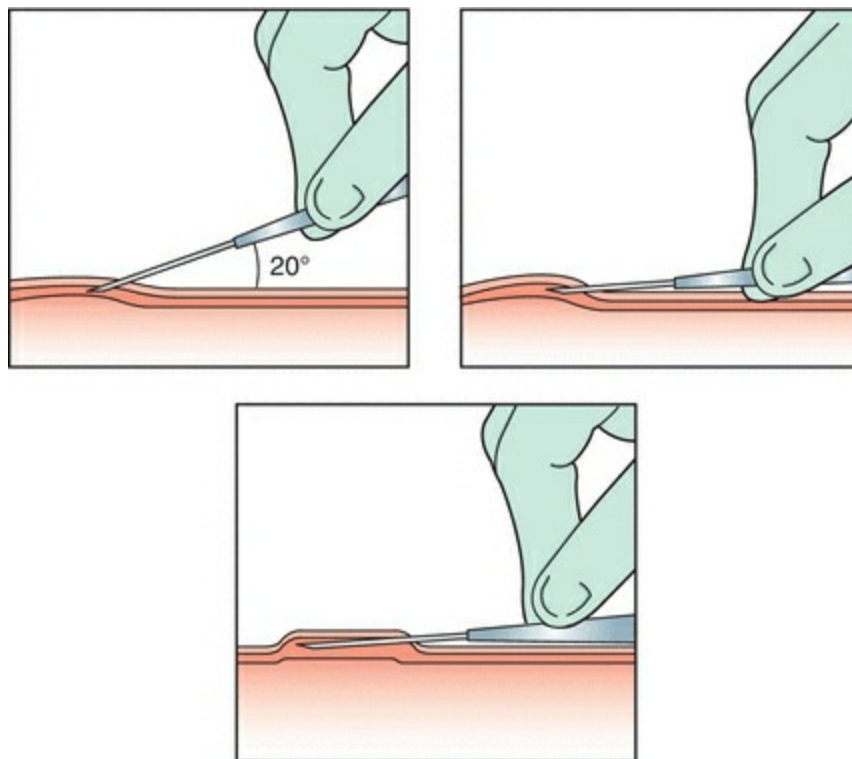
The patient is placed in a supine position with the full length of her arm exposed. The

upper inner arm is positioned by bending the elbow to 90 degrees and rotating the arm out, allowing full exposure of the insertion site at the crease between the biceps and triceps muscles. Adequate support under the arm should be provided to ensure comfort. To minimize the risk of infection, strict aseptic technique should be maintained throughout the procedure. An insertion site approximately 8–10 cm superior and lateral to the medial epicondyle of the humerus is identified. A sterile drape is placed under the arm, and the insertion site on the arm is cleaned with an antiseptic such as povidone-iodine.

## Anesthesia

Local anesthesia for the incision is obtained by raising a wheal of 1% chloroprocaine or lidocaine using a 25-gauge needle and injecting 2 mL under the skin along the track of the implant insertion needle.

**Verify the presence of Nexplanon** by looking carefully at the tip of the needle. If the implant (a white rod) is not visible, turn the applicator needle down and gently tap on a surface with the needle cover in place until the Nexplanon is seen; then tap the base of the applicator with the needle pointed up until the implant is no longer visible. Keep the applicator sterile ([Figure 23.3](#)).



**FIGURE 23.3**



## Incision and Placement

The insertion needle can be pushed directly through the skin at no greater than a 20-degree angle without making an incision. The needle is advanced as superficially as possible under the skin by maintaining a slightly upward angle on the trocar. To minimize the chance of too deep insertion, lift or tent the skin with the tip of the needle. If the skin dimples, the needle is too superficial. Pull the needle back and redirect. Advance the needle to its full length while applying counter traction to the skin at the insertion site.

Once the needle has been fully advanced, move the purple slider on the applicator fully back until it stops. This will retract the needle inside the body of the applicator. The applicator can then be removed.

Immediately after insertion, palpate the implant to verify correct insertion (both ends should be palpable). Show the patient how to palpate the implant. If the implant is not palpable, look at the applicator and verify that only the purple tip of the obturator is visible inside the needle (the white rod cannot be seen). The location can also be confirmed with ultrasound or x-ray, and alternative contraception should be used until the location is confirmed. After the insertion, place an adhesive closure or bandage over the insertion site. Complete the patient chart label and the “User Card” that must be given to the patient.

Most women experience little pain during the insertion,<sup>103</sup> but if it occurs, the discomfort can be relieved with aspirin, acetaminophen, or a nonsteroidal anti-inflammatory agent. Infection or expulsion of the implants is rare (<1% with the Norplant system) and usually occurs when an implant is left pressing against the incision.<sup>106</sup>

The most commonly reported discomfort is a burning sensation during the injection of the local anesthetic. This effect of local anesthetic can be eliminated for most patients by adding 1 mEq of sodium bicarbonate to each 10 mL of anesthetic (this shortens shelf life to 24 hours).<sup>109</sup> After the onset of anesthesia in 2–3 minutes, most women feel no more than a pressure sensation.

# Complications of Insertion

Potential complications include infection, hematoma formation, local irritation or rash over the implants, expulsion of the implant, and allergic reactions to adhesives of the dressing. Etonogestrel implants can migrate a short distance (<2 cm) over time.<sup>110</sup> The incidence of complications is minimized by clinician training and experience and the use of strict aseptic technique.

## Infection

The rate of infection varies among clinics and countries. The overall risk of infection after Norplant insertion is 0.8%.<sup>111</sup> Infections usually occur within the 1st week after insertion but can present as long as 4–5 months later. Infection can be treated either by the removal of the implant or the administration of oral antibiotics while the implant remains in place. One-third of insertion site infections treated with antibiotics are unresponsive to therapy and require removal.<sup>111</sup> There have been no reports of infections leading to serious injury. Rarely, a superficial phlebitis develops. If it resolves over 1–2 weeks with heat and elevation of the arm, the implants need not be removed.

## Expulsion

Expulsion of one or more of the implants occurs in 0.4% of Norplant users, usually within the first few months.<sup>111</sup> In a large systematic review, no etonogestrel implant expulsions were noted.<sup>50</sup> The majority of expulsions are associated with concurrent infection at the insertion site. Another cause of expulsion is failure to advance the implants far enough from the incision, causing pressure on the incision by the distal tip of the implant.

## Local Reactions

Although not common, hematomas can form. The use of a pressure dressing for 72 hours will prevent enlargement. Application of an ice pack for 30 minutes immediately after insertion also helps. Local irritation, rash, pruritus, and pain occur in 4.7% of Norplant users, usually during the 1st month of use.<sup>111</sup> Allergies to skin closure strip adhesives or to latex gloves account for some reactions.<sup>112</sup> These problems resolve spontaneously, but itching can be relieved by topical corticoid steroids.

# Removal Techniques

Although implant removal is an office procedure requiring only a small amount of local anesthesia and a few simple instruments, instruction and practice are necessary.<sup>106,107</sup>

Practicing on a model arm after viewing an instructional video makes first removals faster and less uncomfortable for both clinician and patient. A removal kit with a model arm, a manual, and a compact disc illustrating the technique is available at no charge from Merck at 877-467-5266. As for insertion, the patient should read and sign an informed consent to be filed in her medical record. We recommend that the patient be given a copy.

Proper positioning of the implant at the time of insertion is the most important factor influencing ease of removal. If the Norplant implants have been inserted with the distal tips (those away from the axilla) far apart or with implants crossing or touching one another or too deeply, a larger incision and more time are required. Removal is easiest when the implants are just under the skin with their distal tips close together in a fan shape. The fibrous sheaths that form around implants can also make removal more difficult, especially if they are dense. The one and two implant systems can be removed faster and with less pain than the six Norplant capsules.<sup>103</sup>

Most removals are not painful (80% of patients reported pain as “none” or “slight”), and systemic analgesia is not required.<sup>108,113</sup> Time for removal of six capsules ranges from 5 to 40 minutes, with an average of 20 minutes. For the single rod (Nexplanon), the average time is about 4 minutes.<sup>108</sup> The most common cause of discomfort during the procedure is injection of the local anesthetic. Patients may feel pressure or tugging from manipulation of the fibrous sheaths and the implants, but these sensations are not severe if the clinician waits a few minutes after injection of the local anesthetic. The sheaths that form around the Nexplanon are less dense than those around Norplant capsules.

## Removal with Instruments

This approach to removal is the one described in the Nexplanon package insert. The patient is placed in a supine position with her arm flexed and externally rotated as for insertion. A sterile towel is placed under the arm. Palpate the implant and mark the end closest to the elbow. Clean the area overlying the implant with an antiseptic solution, preparing a wide area above and below the implant so that the incision won't be contaminated during manipulations for removal. Drape the arm with a fenestrated towel and use a third towel to create a sterile field for instruments on a Mayo stand or table.

Wearing sterile gloves, an incision site is selected by pressing down on the

proximal end of the implant and palpating their distal tips with a finger. Careful selection of the incision site is the most critical step for easy removal. The best incision site is right at the distal tip. This may be the same as the insertion site, but generally the removal incision is made a few millimeters higher up on the arm to ensure placing it as close as possible to the tip of the implant.

A local anesthetic containing 1:100,000 epinephrine reduces bleeding and allows better visualization of the implants. The 25-gauge needle is used to raise a wheal of local anesthetic just under the tip of the implant. About 1 mL is sufficient, although more may be required later. Injection of too much anesthetic over the implant can obscure the tip and make removal more difficult. A 2-mm incision is made with the no.11 scalpel at the preselected incision site. Implants can be removed by the clinician either sitting or standing, but if sitting, a wheeled stool allows repositioning as needed.

The implant is pushed gently toward the incision with the fingers until the tip is visible and can be grasped with a curved mosquito clamp. If a fibrous sheath is covering the implant, it is incised with the scalpel and the implant can be removed with forceps. If the implant tip cannot be guided to the incision with digital pressure on the skin at the proximal end of the implant, the jaws of the straight mosquito are inserted into the incision and opened just beneath the skin to separate the tissue layers. The curved clamp is inserted with the tips pointing upward toward the skin. The clamp is opened and the implant is guided down between the jaws with a forefinger on the skin above the implant. This downward pressure on the tips of the clamp is often the most painful part of the removal procedure. When the implant is pushed between the jaws of the clamp, the clamp is secured at the first or second ratchet. Too much pressure on the implant can fracture the silastic capsule, making removal more difficult. If the implant cannot be seen, after gentle traction, the clamp handle is flipped 180 degrees until it points in the opposite direction, toward the patient's head. A portion of the sheath is cleared with an opened sponge, or if necessary, the scalpel tip, incising longitudinally, not across the implant. The exposed portion is then grasped with the straight clamp, the curved clamp is released, and the implant is removed with gentle traction.

At the completion of the procedure, the implant should be inspected and measured to be sure it was removed in its entirety. The Nexplanon rod is 4 cm long. An adhesive strip is used to close the incision while pinching the skin edges together. A pressure dressing is then applied as after insertion and removed the next day. The fibrous sheath can remain for months causing the patient to think that implants were left behind. For that reason, it is important to show the implant to the patient at the time of removal.

If removal of some of the implant is difficult, painful, or prolonged, the procedure should be interrupted, and the patient should return in a few weeks to complete the removal. The location of the implant should always be known, either through palpation or imaging, prior to attempts at removal. A new incision can be made closer to the

implant or portion of implant that was difficult to remove the first time. Even if a portion of the implant remains, the patient should immediately begin to use another method of contraception.

## Difficult Removals

The incidence of difficult removals in the large postmarketing surveillance study of Norplant was 10.1 per 1,000 removals.<sup>94</sup> For the etonogestrel implant, the rate of difficult removals was 1.4 per 1,000 removals.<sup>107</sup> Removal is more difficult if the implant system is broken during attempts to extract them. Once an implant is damaged, it can fracture repeatedly with further attempts to grasp it with clamps. To decrease this risk, the implants should be grasped at their ends whenever possible and as little traction as possible should be used for exposure and removal. If the scalpel is required to open the fibrous sheath around the implant, care should be taken to avoid slicing the capsule. If it has not been possible to grasp the end of implant, in order to open the fibrous sheath, cut longitudinally along the length of the implant, not across. Rarely, removal of cut or broken implants will require an additional incision at the proximal end of the implant so that the remaining piece can be removed. Even more rarely, an implant can neither be palpated under the skin nor found through an incision. Such “lost” implants are most easily located with a high-frequency (7–10 mHz), short-focus ultrasound just prior to the removal procedure to help place the incision directly over the implant.<sup>114</sup> Use a transverse orientation to identify the shadow (the implant itself is more difficult to see), reposition the transducer to identify its length and both ends, and measure the depth with electronic calipers. Draw lines representing the location on the surface of the skin. Real-time sonography guidance can be useful during the removal procedure. Because it is readily available and can be employed during removal, sonography is a first choice. If a Nexplanon cannot be identified with ultrasonography, an x-ray can allow for better localization.

## Reinsertion

A new implant can be inserted immediately through the same incision used to remove the old implant, or a new implant can be placed in the other arm.

# Reasons for Termination

Approximately 56% of women continue etonogestrel implants for the entire 3 years.<sup>115</sup> Discontinuation of implants occurs at a rate of 10–15% yearly, about the same as for intrauterine contraception but lower than for barrier or oral contraception.<sup>16,58,115,116,117</sup> Bothersome side effects, such as menstrual changes, headache, or weight change, are the primary reasons for termination of implant use.<sup>43,93,118,119</sup> Menstrual changes are the most common cause for discontinuation of implants in the 1st year of use. An unspoken concern for many patients and their partners is the fact that bleeding irregularity interferes with sexual interactions. Users who cannot tolerate these symptoms request removal in the first 2 years of use, whereas women who want another pregnancy, the most common personal reason for removal, are more likely to terminate use in the 3rd or 4th year.

# User Acceptance of Contraceptive Implants

Overall, interview surveys throughout the world have indicated that women perceive sustained-release methods as highly acceptable methods of contraception.<sup>102,119,120</sup> The most popular feature of implants is their ease of use. Approximately 20% of US patients reported that friends and relatives notice their implants. This may be a greater problem in warmer climates with less encompassing clothing. Only 25% of the women who report that the implants were noticed were bothered by this attention.<sup>3</sup>

In the United States, the primary motivations for implant use have been problems with previous contraceptive methods and ease of implant use. Although fear of pain during implant insertion is a prominent source of anxiety for many women, the actual pain experienced does not match the expectations. The level of satisfaction has been high in self-motivated and well-informed users.<sup>4</sup> Teenagers provide an example of well-documented success. Their 1-year pregnancy rates are much lower, and continuation rates much higher than that with oral contraceptives.<sup>50,121,122,123,124</sup> However, teenage discontinuation of the method due to side effects (especially irregular bleeding and weight gain) is more common with Norplant.<sup>48</sup> The lower rate of irregular bleeding with Nexplanon contributes to higher patient acceptability, but irregular bleeding continues to be the major reason for discontinuation.<sup>14,119</sup>

# Counseling Women

Frank information about negative factors such as irregular bleeding will avoid surprise and disappointment and encourage women to continue use long enough to enjoy the positive attributes such as convenience, safety, and efficacy. Open discussion of side effects will lead to public and media awareness of the disadvantages as well as the advantages of these methods. Helping women decide if they are good candidates for use of implants before they invest too much time and money in long-acting contraception is a very important objective of good counseling.

Common patient questions regarding contraceptive implants are as follows:

- Is it effective?
- How is it inserted and removed; how long do these procedures take; does it hurt; and will it leave scars?
- Will the implants be visible under the skin?
- Will the implants be uncomfortable or restrict movement of the arm?
- Will the implants move in the body?
- Will the implants be damaged if they are touched or bumped?
- Will this contraceptive change sexual drive and enjoyment?
- What are the short- and long-term side effects?
- Are there any effects on future fertility?
- What do the implants look and feel like?
- What happens if pregnancy occurs during use?
- How long will it take for the method to be effective after insertion?
- Can a partner tell if this method is being used?



## Other Single-Rod Systems

Uniplant (also Surplant) is a single implant contraceptive, containing 55 mg nomegestrol acetate in a 4-cm silicone capsule with a 100 mg/day release rate. It provides contraception for 1 year.<sup>125</sup> A single silicone implant containing nesterone (Nestorone) is effective for 2 years; another version (Elcometrine) lasts 6 months.<sup>126,127</sup>

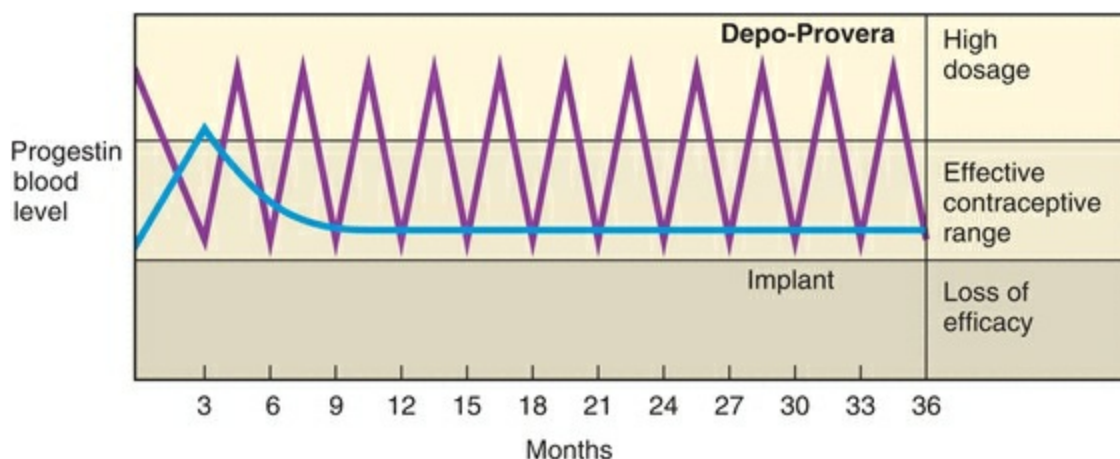
# INJECTABLE CONTRACEPTION

Depot-medroxyprogesterone acetate (Depo-Provera) is the most thoroughly studied progestin-only contraceptive. It has been available in some countries since the mid-1960s and in the United States since 1992. Much of our knowledge of the safety, efficacy, and acceptability of long-acting hormonal contraception comes from Indonesia, Sri Lanka, Thailand, and Mexico where depot-medroxyprogesterone acetate has been used and studied for decades. The long-delayed approval as a contraceptive in the United States was based on political and economic considerations, not scientific ones.<sup>128</sup>

Depot-medroxyprogesterone acetate is formulated as microcrystals, suspended in an aqueous solution. The correct dose for contraceptive purposes is 150 mg intramuscularly (gluteal or deltoid) every 3 months. A comparative trial established that the 100-mg dose is significantly less effective.<sup>129</sup> The contraceptive level is maintained for at least 14 weeks, providing a safety margin for one of the most effective contraceptives available, about 1 pregnancy per 100 women after 5 years of consistent use.<sup>129,130</sup>

A newer formulation allows the self-administration into a thigh or the abdomen of a subcutaneous dose of 104 mg every 3 months.<sup>131,132,133</sup> Prefilled syringes contain 0.65 mL of an aqueous suspension of medroxyprogesterone acetate.

Depot-medroxyprogesterone acetate is not a “sustained-release” system; it relies on higher peaks of progestin to inhibit ovulation and thicken cervical mucus. The difference between serum levels of progestins in a sustained-release system like Nexplanon and a depot system like depot-medroxyprogesterone acetate is illustrated in [Figure 23.4](#).



**FIGURE 23.4**

Other widely used injectables are norethindrone enanthate, 200 mg every 2 months, and the monthly injectables, Lunelle (25 mg medroxyprogesterone acetate and 5 mg estradiol cypionate) and Mesigyna (50 mg norethindrone enanthate and 5 mg estradiol valerate).

# Mechanism of Action

The mechanism of action of depot-medroxyprogesterone acetate is different from the other lower-dose, progestin-only methods because, in addition to thickening of the cervical mucus and alteration of the endometrium, the circulating level of the progestin is high enough to effectively block the LH surge, and, therefore, ovulation does not occur.<sup>134</sup> FSH is not suppressed as it is with the combination oral contraceptive; therefore, follicular growth is maintained sufficiently to produce estrogen levels comparable to those in the early follicular phase of a normal menstrual cycle.<sup>135</sup> Symptoms of estrogen deficiency, such as vaginal atrophy or a decrease in breast size, do not occur.

Accidental pregnancies occurring at the time of the initial injection of depot-medroxyprogesterone acetate have been reported to be associated with higher neonatal and infant mortality rates, probably due to an increased risk of intrauterine growth restriction.<sup>136,137</sup> The timing of the first injection is, therefore, very important. To ensure effective contraception, the first injection should be administered within the first 5 days of the menstrual cycle (before a dominant follicle emerges), or a backup method is necessary for 7 days.<sup>131,138,139,140</sup> The Quick Start, same-day start protocol can be used with depot-medroxyprogesterone acetate, with special care to rule out pregnancy and providing a backup method for 7 days.<sup>141</sup> Same-day starts with depot-medroxyprogesterone acetate produce better continuation rates with fewer unintended pregnancies.<sup>142</sup>

The duration of action can be shortened if attention is not paid to proper administration. The intramuscular injection must be given deeply by the Z-track technique and not massaged. It is prudent to avoid locations at risk for massage by daily activities.

When given properly, there is an effective 2-week grace period that allows for late reinjections; a study of women arriving late for reinjections concluded that even a 4-week late reinjection provided equivalent protection against pregnancy.<sup>143</sup> Women who are more than 4 weeks late for reinjection should be tested for pregnancy, reinjected if the test is negative, and advised to use backup contraception for 7 days.

# Efficacy

The efficacy of this method (in both the intramuscular and subcutaneous formulations) is slightly better than that of sterilization and better than that of all the other temporary methods.<sup>49,50,131,132,133,144,145</sup> In a comparison of the intramuscular and subcutaneous methods, the blood levels of medroxyprogesterone acetate are approximately 30% lower with subcutaneous administration of the lower dose, but efficacy is not impaired.<sup>131</sup> Because serum concentrations are relatively high, efficacy is not influenced by weight (making this method a good choice for overweight women) or by the use of medications that stimulate hepatic enzymes.<sup>131,132</sup>

# Indications

1. At least 1 year of birth spacing desired
2. Highly effective long-acting contraception not linked to coitus
3. Private, coitally independent method desired
4. Estrogen-free contraception needed
5. Breast-feeding
6. Sickle cell disease
7. Seizure disorder

# **Absolute Contraindications**

1. Pregnancy
2. Unexplained genital bleeding
3. Severe coagulation disorders
4. Previous sex steroid-induced liver adenoma

# Relative Contraindications

1. Liver disease
2. Severe cardiovascular disease
3. Rapid return to fertility desired
4. Difficulty with injections
5. Severe depression



# Advantages

Like sustained-release forms of contraception, depot-medroxyprogesterone acetate is not associated with compliance problems and is not related to the coital event. Continuation rates are better and repeat pregnancy rates are reduced compared with oral contraceptive use in teenagers; however, continuation and repeat pregnancy rates are similar when adolescents begin these methods in the immediate postpartum period.<sup>146,147</sup> Depot-medroxyprogesterone acetate is useful for women whose ability to remember contraceptive requirements is limited. It should be considered for women who lead disorganized lives or who are mentally challenged.

The freedom from the side effects of estrogen allows depot-medroxyprogesterone acetate to be considered for patients with congenital heart disease, sickle cell anemia, patients with a previous history of thromboembolism, and women over age 30 who smoke or have other risk factors such as hypertension or diabetes mellitus. The absolute safety in regard to thrombosis is mainly theoretical; it has not been proven in a controlled study. However, an increased risk of thrombosis has not been observed in epidemiologic evaluation of depot-medroxyprogesterone acetate users nor in a systematic review, and a World Health Organization (WHO) case-control study could find no evidence for increased risks of stroke, myocardial infarction, or venous thromboembolism.<sup>130,148,149</sup>

Two case-control studies, one using data from the WHO Collaborative Study and one using the data from the UK general practice research database, assessed the risk of idiopathic venous thrombosis in users of progestins alone for therapeutic purposes, not for contraception, and concluded that therapeutic progestins alone may be associated with an increased risk of venous thromboembolism.<sup>150,151</sup> These epidemiologic conclusions were based on extremely small numbers (only three cases in one report and five in the other) and had very wide confidence intervals. Patients who receive progestin only for therapeutic reasons are probably older and are more likely to have family histories of cardiovascular disease. In addition, a problem of preferential prescribing is present in that clinicians are more likely to promote the use of progestin only for women they perceive to be at greater risk of venous thromboembolism. Thus, it is likely that the case groups represented a higher risk group than the control groups in these reports. For these reasons, we do not believe progestins are associated with an increased risk of venous thromboembolism.

An important advantage exists for patients with sickle cell disease because evidence indicates an inhibition of in vivo sickling with hematologic improvement during treatment.<sup>152</sup> Both the frequency and the intensity of painful sickle cell crises are reduced.<sup>153</sup>

Another advantage is the finding that depot-medroxyprogesterone acetate increases the quantity of milk in nursing mothers, a direct contrast to the effect seen with estrogen-progestin oral contraception. The concentration of the drug in the breast milk is negligible, and no effects of the drug on infant growth and development have been observed.<sup>154,155,156</sup> In a careful study of male infants being breast-fed by women treated with depot-medroxyprogesterone acetate, no metabolites of depot-medroxyprogesterone acetate could be detected in the infant's urine, and no alterations could be observed in the infant levels of FSH, LH, testosterone, and cortisol.<sup>157</sup> Because of the slight positive impact on lactation, depot-medroxyprogesterone acetate can be administered immediately after delivery. A study to investigate the impact of early initiation found no adverse effects on breast-feeding.<sup>158</sup> In breast-feeding, overweight, Latina women with prior gestational diabetes, depot-medroxyprogesterone acetate was associated with a small increase in subsequent diabetes mellitus that was not statistically significant, a risk that was even lower and less significant when adjusted for the higher body weights and a greater prevalence of family history for diabetes in the users of injected contraception.<sup>159</sup>

Depot-medroxyprogesterone acetate is an excellent contraceptive choice for women taking antiepileptic drugs because the high progestin levels raise the seizure threshold.<sup>160</sup> An improvement in seizure control can be achieved probably because of the sedative properties of progestins.<sup>160</sup>

Women who are anticoagulated or who have bleeding disorders are prone to develop heavy menstrual bleeding and hemorrhagic ovarian cysts. Experience with depot-medroxyprogesterone acetate in these patients is limited; however, we would expect a beneficial reduction in bleeding and a reduced risk of ovarian hemorrhage, especially from a corpus luteum.<sup>161</sup>

Other benefits associated with depot-medroxyprogesterone acetate use include a decreased risk of endometrial cancer comparable with that observed with oral contraceptives.<sup>162</sup> A case-control study showed an association between 3 or more years of depot-medroxyprogesterone use and reduced risk of epithelial ovarian cancer.<sup>163</sup> A failure to document a reduced risk of ovarian cancer by the World Health Organization probably reflects the study's low statistical power and the high parity in the depot-medroxyprogesterone acetate users.<sup>164</sup> Depot-medroxyprogesterone has also been associated with other benefits of the progestin component of oral contraceptives, including decreased development of uterine fibroids,<sup>165</sup> decreased risk of ectopic pregnancy,<sup>55</sup> and less pelvic inflammatory disease (PID).<sup>166</sup>

The greater the number of choices that women have, the more likely they are to find a contraceptive that works well for them. For some women, the primary advantages of

depot-medroxyprogesterone acetate are privacy and ease of use. No one but the user needs to know about the injection, and the 3-month schedule can be easy to maintain for women who do not mind injections. In some societies, depot-medroxyprogesterone acetate is the most popular contraceptive despite bleeding changes and other side effects.

## Key Points: Summary of Advantages

- Easy to use, no daily or coital action required
- Safe, no serious health effects
- Very effective, as effective as sterilization, intrauterine contraception, and implant contraception
- Free from estrogen-related problems
- Private, use not detectable
- Lactation enhanced
- Noncontraceptive benefits

# Problems with Depot-Medroxyprogesterone Acetate

Major problems with depot-medroxyprogesterone acetate are irregular menstrual bleeding, breast tenderness, weight gain, and depression.<sup>129,130</sup> By far, the most common problem is the change in menstrual bleeding. Up to 25% of patients discontinue in the 1st year because of irregular bleeding.<sup>130</sup> The incidence of irregular bleeding is 70% in the 1st year, and 10% thereafter. Bleeding and spotting decrease progressively with each reinjection so that after 5 years, 80% of users are amenorrheic (compared with 10% of Norplant users).<sup>167</sup> With the subcutaneous preparation, the bleeding pattern is similar to that with the intramuscular product; 55% achieve amenorrhea at the end of the 1st year of treatment and 70% after 2 years.<sup>132,145,168</sup> Irregular bleeding can be disturbing and annoying, and, for many patients, it inhibits sexuality; therefore, most users prefer the amenorrhea that comes with prolonged use.

If necessary, breakthrough bleeding can be treated with exogenous estrogen, 1.25 mg conjugated estrogens, or 2 mg estradiol, given daily for 7 days. A nonsteroidal anti-inflammatory product given for a week is also effective, and another option is to administer an oral contraceptive for 1–3 months. Giving the depot-medroxyprogesterone acetate injection earlier (more frequently) does not change the bleeding pattern.<sup>169</sup> Most women can wait for amenorrhea without treatment if they know what to expect with time. Trying to regulate breakthrough bleeding with planned cyclic transdermal estradiol exposure has proved to be ineffective.<sup>170</sup> Chlamydia infection of the endometrial cavity is not a cause of the irregular bleeding associated with depot-medroxyprogesterone acetate.<sup>171</sup>

In a large international study, the most common medical reasons for discontinuing depot-medroxyprogesterone acetate during the first 2 years of use are noted in [Table 23.5](#).<sup>30</sup>

## TABLE 23.5 Common Medical Complaints for Discontinuing the Use of Depot-Medroxyprogesterone Acetate

Headaches	2.3%
-----------	------

Weight gain	2.1%
-------------	------

Dizziness	1.2%
-----------	------

Abdominal pain	1.1%
----------------	------

Anxiety	0.7%
---------	------

In Western societies, depression, fatigue, decreased libido, and hypertension are also encountered. Whether medroxyprogesterone acetate causes these side effects is difficult to know because they are very common complaints in nonusers as well.<sup>172</sup> When studied closely, no increase in depressive symptoms can be observed, even in women with significant complaints of depression prior to treatment.<sup>173,174</sup> In postpartum women, a randomized controlled trial comparing depot-medroxyprogesterone to the copper-containing IUD did show higher scores on depression inventories in women using injectable contraception, as well as higher rates of major depression at 3 months of postpartum.<sup>175</sup>

Attempts to document a greater weight gain specifically associated with depot-medroxyprogesterone acetate have had mixed results, some finding no increase and others a small increase (e.g., about 4 kg over 5 years in one study and 11 kg over 10 years in another).<sup>176,177,178,179</sup> In an excellent large cohort study, 3-year users of depot-medroxyprogesterone acetate increased their body weight by 5.1 kg, body fat by 4.1 kg, and percent body fat by 3.4% and developed an increase in central, visceral fat, all mostly in the first 18 months and in contrast to no weight gain in oral contraceptive users.<sup>180</sup> With the subcutaneous method, an average weight gain of 1.5 kg was observed after 1 year and 4.5 kg after 3 years, changes that are comparable to the intramuscular formulation.<sup>132,145,181</sup> In a cohort comparison study of adolescents, obese girls gained more weight (9.4 kg after 18 months) with depot-medroxyprogesterone acetate when compared with oral contraceptives or no hormonal method.<sup>182</sup> A longitudinal 4–5-year follow-up study of adolescents in South Africa documented about a 4 kg greater weight gain with injectable contraception (both depot-medroxyprogesterone acetate and

norethindrone enanthate) compared with nonusers or oral contraceptive users.<sup>183</sup> Specific individuals and certain ethnic groups may be more susceptible to weight gain; for example, significant weight gain was reported in Navajo women using depot-medroxyprogesterone acetate.<sup>184,185</sup> In a prospective cohort study, women who experienced a significant weight gain within 6 months gained an average of about 7 kg more over 3 years, thus identifying a susceptible group of women, about 25% of depot-medroxyprogesterone acetate users.<sup>186</sup>

Is weight gain a general reaction to depot-medroxyprogesterone acetate or does it occur only in vulnerable individuals? An answer to this question is hindered by limitations in the available studies. The evidence is not derived from randomized trials. Therefore, results can be influenced by those reasons for which subjects choose a certain method and responses that affect continuation with methods. The individuals who choose to use depot-medroxyprogesterone differ in their socioeconomic status, contraceptive practices, and sexual histories, thus the difficulty in matching users and nonusers.

**Although it is difficult to separate the hormone effect from the impact of lifestyle and aging, it is best to conclude that depot-medroxyprogesterone acetate injections are associated with a small increase in body fat and body weight in some women.**

Remember that if symptoms are truly due to the progestin, unlike pills and implants, depot-medroxyprogesterone acetate takes 6–8 months to be gone after the last injection.<sup>131</sup> Clearance is slower in heavier women. Approximately half of women who discontinue depot-medroxyprogesterone acetate can expect normal menses to return in 6 months after the last injection, but 25% will wait a year before resumption of a normal pattern.<sup>131,167</sup>

Several prospective studies have suggested that the use of depot-medroxyprogesterone acetate is associated with an increased risk of cervical infections, especially chlamydia and/or gonorrhea.<sup>187,188,189,190</sup> This finding could very well be influenced by the inability to perform a randomized trial and reflect the difficulty in matching users and nonusers. The women who chose to use depot-medroxyprogesterone acetate in these cohort studies were notably different in their socioeconomic status, contraceptive practices, and sexual histories; thus, the results could reflect a higher rate of infection in the user group at baseline. Studies have not linked the use of depot-medroxyprogesterone acetate and an increased risk of HIV infection.<sup>191,192</sup>

## **Anaphylaxis**

As of 2017, there were four case reports of anaphylactic shock within minutes after

receiving intramuscular injections of depot-medroxyprogesterone acetate.<sup>193,194,195,196</sup> The reactions were most likely to one of the inert substances present in the injections: parabens, polyethylene glycols, and polysorbates. Depot-medroxyprogesterone acetate intramuscular injections are best given by trained personnel in a clinic or office setting with resuscitation equipment and drugs available. No such reactions have been reported with subcutaneous administration.

## Breast Cancer

A very large, hospital-based, case-control WHO study conducted over 9 years in three developing countries indicated that exposure to depot-medroxyprogesterone acetate is associated with a very slightly increased risk in breast cancer in the first 4 years of use, but there was no evidence for an increase in risk with increasing duration of use.<sup>197</sup> The number of cases with recent use was not large, and the confidence intervals reflected this. A possible explanation for this finding is the combination of detection/surveillance bias and accelerated growth of an already present tumor, a situation similar to those described with oral contraceptives ([Chapter 22](#)) and postmenopausal hormone therapy ([Chapter 17](#)).

Two earlier population-based, case-control studies indicated a possible association between breast cancer and depot-medroxyprogesterone acetate. One, from Costa Rica, was based on only 19 cases.<sup>198</sup> The other, from New Zealand, did not find an increased relative risk in ever users but did find an indication of increased risk shortly after initiating use at an early age, younger than age 25.<sup>199</sup> A pooled analysis of the WHO and New Zealand data indicated an increased risk in recent users and that the highest risk was in women who had received a single injection.<sup>200</sup> The risk, if real, is very slight, and it is equally possible that the suggestions of increased risk based on a small number of cases have not been free of confounding variables. A case-control study from Cape Town, South Africa, and a very large case-control study in the United States found no overall increase in the risk of breast cancer and no effect of increasing duration of use or recent use.<sup>99,201</sup> Because recent use may be the key factor, it is appropriate to emphasize that all of these studies did not find evidence for an overall increased risk of breast cancer, and the risk did not increase with duration of use. However, clinicians should consider informing patients that depot-medroxyprogesterone acetate might accelerate the growth of an already present occult cancer. We would expect such tumors to be detected at an earlier stage and grade of disease and to be associated with a better outcome.

## Other Cancers

An increased risk of cervical dysplasia cannot be documented even with long-term use

(4 or more years).<sup>202</sup> No increase in adenocarcinoma or adenosquamous carcinoma of the cervix could be detected in the WHO study.<sup>203</sup> The WHO study did not detect an increased risk of invasive squamous cell cancer of the cervix in depot-medroxyprogesterone acetate users; however, the risk of cervical carcinoma in situ was slightly elevated in the WHO case-control study, and it is not certain whether this is a real finding or a consequence of unrecognized biases, especially detection bias.<sup>204,205</sup> In New Zealand, a modest increase in the risk of cervical dysplasia among users of depot-medroxyprogesterone acetate could be attributed to an increased prevalence of known risk factors for dysplasia among women who choose this method of contraception.<sup>202</sup> Nevertheless, it is prudent to insist on Pap smear surveillance in all users of contraception, no matter what method. An immature cellular pattern in Pap smears from long-term depot-medroxyprogesterone acetate users can suggest the presence of squamous intraepithelial premalignant lesions, but biopsies in these cases reveal epithelial atrophy.<sup>206</sup>

As noted, depot-medroxyprogesterone acetate is associated with a reduction in the risk of endometrial cancer, and there is probably a modest reduction in the risk of ovarian cancer. There is no evidence that liver cancer risk is changed by the use of depot-medroxyprogesterone acetate.<sup>207</sup>

## Metabolic Effects

The impact of depot-medroxyprogesterone acetate on the lipoprotein profile is uncertain. Although some fail to detect an adverse impact and claim that this is due to the avoidance of a first pass through effect in the liver, others have demonstrated at least a transient decrease in HDL cholesterol and increases in total cholesterol and LDL-cholesterol.<sup>208,209,210</sup> In a multicenter clinical trial by the World Health Organization, the adverse impact was present only in the few weeks after injection when blood levels were high.<sup>211</sup> The clinical impact of these changes, if any, has yet to be reported.

There are no clinically significant changes in carbohydrate metabolism or in coagulation factors in healthy women.<sup>212,213</sup> As noted earlier, the use of progestin-only contraception may increase the risk of type 2 diabetes mellitus, especially in Latina breast-feeding women.<sup>159</sup> However, these studies have also indicated that this risk is influenced by baseline body weights and by weight gain. It is possible that overweight women who already have significant insulin resistance become overtly diabetic by the added effect of progestins in a low-estrogen environment (lactation) or in an induced relatively low-estrogen state (depot-medroxyprogesterone acetate). But, it is likely that excess body weight is the more critical factor.



## Effect on Bone Density

The contraceptive use of depot-medroxyprogesterone acetate is associated with the short-term loss of bone. This is attributed to the fact that blood levels of estrogen with depot-medroxyprogesterone acetate are relatively lower over a period of time compared with a normal menstrual cycle, an explanation that is supported by the demonstration that estrogen treatment prevents the bone loss.<sup>213,214</sup> Lumbar and hip bone loss has been documented in both cross-sectional and longitudinal studies.<sup>91,215,216,217,218,219</sup> This bone loss has also been observed in women receiving a high oral dose of medroxyprogesterone acetate, 50 mg daily, a dose that suppresses LH, resulting in low estrogen levels.<sup>220</sup> Another study documented decreased bone density that was enhanced by lower body weight and duration of amenorrhea.<sup>221</sup> An American cross-sectional study indicated a greater bone loss with increasing duration of use, especially in younger women, 18–21 years old.<sup>222</sup> The bone loss with intramuscular and subcutaneous administration of depot-medroxyprogesterone acetate is comparable.<sup>133</sup>

The bone loss associated with the use of depot-medroxyprogesterone acetate can be minimized by focusing on risk factors. Women at greater risk for losing bone density with this method of contraception are those who have not experienced childbirth, who smoke, and who have an inadequate intake of calcium.<sup>223</sup> Calcium and vitamin D supplementation should be encouraged in most women, not just depot-medroxyprogesterone acetate users, and an emphasis on smoking cessation is always worthwhile. A randomized controlled trial also showed that patients using DMPA for more than 2 years had an arrest of bone loss when randomized to receive conjugated estrogens.<sup>224</sup>

Bone density increases rapidly and significantly during adolescence. Almost all of the bone mass in the hip and the vertebral bodies will be accumulated in young women by age 18, and the years immediately following menarche is especially important.<sup>225,226</sup> For this reason, any drug that prevents this increase in bone density might increase the risk of osteoporosis later in life. Studies in adolescents have documented bone loss with depot-medroxyprogesterone acetate compared with normal controls and young women using oral contraceptives.<sup>87,227,228</sup> But, there are reasons to expect this bone loss is regained.

An example of bone loss that is regained is the bone loss associated with lactation. Secretion of calcium into the milk of lactating women approximately doubles the daily loss of calcium.<sup>229</sup> In women who breast-feed for 6 months or more, this is accompanied by significant bone loss even in the presence of a high calcium intake.<sup>230</sup> However, bone density rapidly returns to baseline levels in the 6 months after

weaning.<sup>231,232,233</sup> The bone loss is due to increased bone resorption, probably secondary to the relatively low estrogen levels associated with lactation. Calcium supplementation has no effect on the calcium content of breast milk or on bone loss in lactating women who have normal diets.<sup>234</sup> Most importantly, studies indicate that any loss of calcium and bone associated with lactation is rapidly restored; therefore, there is no impact on the risk of postmenopausal osteoporosis.<sup>235,236,237,238,239</sup>

The degree of bone loss in the previously mentioned depot-medroxyprogesterone acetate studies is not as severe as that observed in the early postmenopausal years. Furthermore, this amount of bone loss is not so great that it cannot be regained. Bone density measurements in women who stopped using depot-medroxyprogesterone acetate indicated that the loss was regained in the lumbar spine but not in the femoral neck within 2 years even after long-term use, but in other cohorts of past users, both spinal density and hip density were regained in the 3–4 years after discontinuation.<sup>216,240,241</sup> A 7-year prospective cohort study demonstrated unequivocally that bone is regained, almost 100% within 2 years after depot-medroxyprogesterone acetate is discontinued in both the lumbar spine and the hip.<sup>242</sup> Cohort studies in adolescents and young women demonstrated a similar gain in bone after discontinuation.<sup>243,244</sup> Most importantly, cross-sectional studies of postmenopausal women in New Zealand and a large multicenter, worldwide population could not detect a difference in bone density comparing former users of depot-medroxyprogesterone acetate to never users, indicating that any loss of bone during use is regained.<sup>91,245</sup>

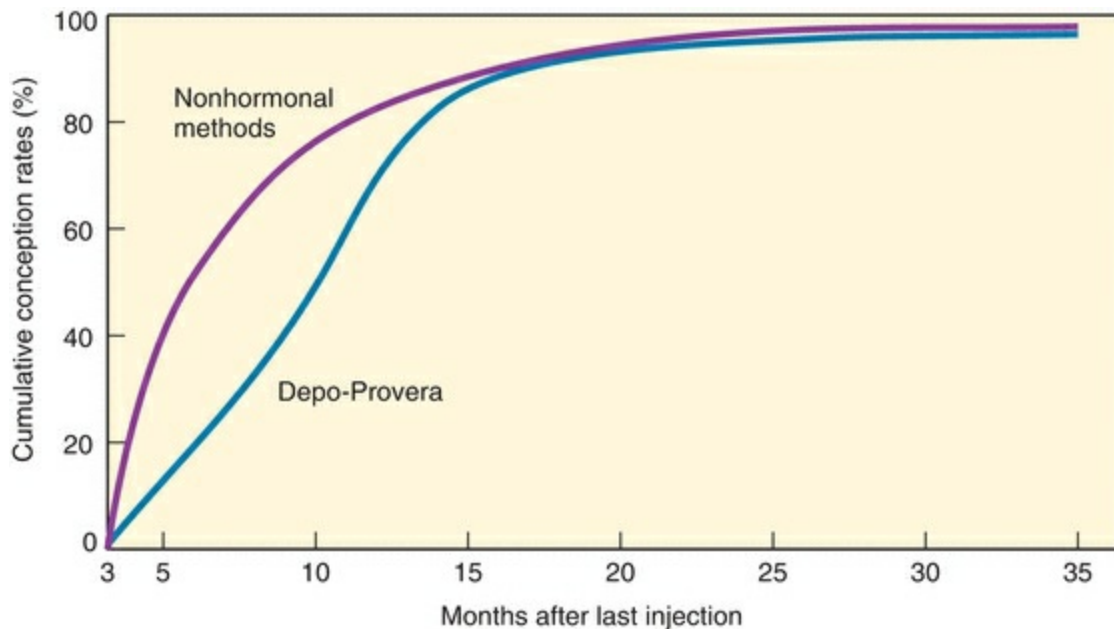
In 2004 (and it stands in the revised 2010 package insert), the U.S. Food and Drug Administration indicated a concern for the bone loss associated with depot-medroxyprogesterone acetate and warned that this method should not be used longer than 2 years unless it was the only option. We agree that concern is appropriate but disagree with the warning. The degree of bone loss and the evidence that the bone loss is regained, plus the similarity to the benign bone loss associated with lactation, all argue that the use and duration of use of depot-medroxyprogesterone acetate should not be limited by this concern and that measurement of bone density or treatment with supplemental estrogen or bisphosphonates is not indicated (and would influence and complicate compliance). At the present time, in our view, the concern over bone loss should not be a reason to avoid this method of contraception, and there is no need to impose a time limit on duration of use. **It is unlikely that bone loss occurs sufficiently to raise the risk of osteoporosis later in life. However, women who discontinue DMPA at or near their menopause should be encouraged to use hormone therapy in order to regain the lost bone.**

## Galactorrhea

Galactorrhea is not associated with the use of depot-medroxyprogesterone acetate. Both estrogen and progesterone are necessary for the expression of the lactogenic receptor, but progesterone antagonizes the positive action of prolactin on its own receptor, while progesterone and pharmacologic amounts of androgens reduce prolactin binding.<sup>246,247,248</sup> For these reasons, exposure to high levels of progestational agents, such as depot-medroxyprogesterone acetate, is not associated with the clinical problem of galactorrhea.

## Effect on Future Fertility

The delay in becoming pregnant after ceasing use of depot-medroxyprogesterone acetate is a problem unique to injectable contraception; all the other temporary methods allow a more prompt return to fertility.<sup>249</sup> However, medroxyprogesterone acetate does not permanently suppress ovarian function, and the concern that infertility with suppressed menstrual function may be caused by depot-medroxyprogesterone acetate has not been supported by epidemiologic data. The pregnancy rate in women discontinuing the injections because of a desire to become pregnant is normal.<sup>250</sup> By 18 months after the last injection, 90% of depot-medroxyprogesterone acetate users have become pregnant, the same proportion as with other methods.<sup>251</sup> The delay to conception is about 9 months after the last injection, and the delay does not increase with increasing duration of use. Because of this delay, women who want to conceive promptly after discontinuing their contraceptive should not use depot-medroxyprogesterone acetate. Suppressed menstrual function persisting beyond 18 months after the last injection is not due to the drug and deserves evaluation (**Figure 23.5**).



## FIGURE 23.5

# Determining Menopause in Long-Term Users

Depot-medroxyprogesterone acetate will prevent the appearance of the two common markers for the onset of menopause: the loss of menstrual periods and hot flushing. Although the risk is small after age 50, pregnancy is still possible in some women. Knowing a woman is postmenopausal is important in order to minimize, if not eliminate, the risk of pregnancy, and there is reason to be concerned over the relatively low-estrogen state associated with depot-medroxyprogesterone acetate. FSH secretion is regulated by both estrogen and inhibin, and therefore pharmacologic amounts of progestins do not restore postmenopausal levels of FSH to premenopausal levels.<sup>252</sup> Greater reliability in measuring FSH is achieved with injectable methods of contraception if the blood sample is obtained prior to the next scheduled injection. We are reluctant to follow the empiric practice that allows women to continue oral contraceptives to age 55 because we believe there is some urgency to expeditiously transfer the patient from the low-estrogen state associated with depot-medroxyprogesterone acetate to the early benefits provided by a program of postmenopausal hormone therapy. We recommend measuring FSH annually beginning at age 50. An FSH level greater than 20 mIU/mL may suggest postmenopause, although a level of 35–40 mIU/mL is considered more reliable.<sup>253</sup> Two spaced measurements indicating menopause will allow reasonable certainty.

# SHORT-TERM CONTRACEPTIVES

# INJECTABLE

---

Monthly or every-other-month injectable combinations of estrogen and progestin are popular in China, Latin America, and Eastern Asia.<sup>254</sup> A preparation widely used in China consists of 250 mg 17 $\alpha$ -hydroxyprogesterone caproate and 5 mg estradiol valerate, known as Chinese Injectable No.1. A large follow-up study of Chinese women concluded that this monthly injection was associated with a significant reduction in endometrial cancer and no increase in other cancers, including breast cancer.<sup>255</sup>

## **Lunelle (Also Called Cyclofem, Cyclo-Provera, Feminena, or Lunella)**

Lunelle consists of 25 mg depot-medroxyprogesterone acetate and 5 mg estradiol cypionate and is administered every 28–30 days (not to exceed 33 days) as a deep intramuscular injection. This method is as effective as depot-medroxyprogesterone acetate but avoids the problems of menstrual irregularity and heavy bleeding, as well as amenorrhea.<sup>256,257,258,259,260,261</sup> In addition, the method is rapidly reversible; fertility rates after discontinuation are similar to oral contraceptives.<sup>262</sup> Besides the need for a monthly injection, another disadvantage is the likelihood that the combination of estrogen and progestin will inhibit lactation. The requirement for a monthly injection can be made more convenient by the use of an automatic device for self-administration.<sup>263</sup> Approximately 80% of women who are amenorrheic on depot-medroxyprogesterone acetate will develop vaginal bleeding if switched to Lunelle.<sup>264</sup> The same contraindications, concerns, problems, and probably benefits reported with oral contraception should apply to Lunelle.

# Norethindrone Enanthate

Norethindrone enanthate is given in a dose of 200 mg intramuscularly every 2 months. This progestin acts in the same way as depot-medroxyprogesterone acetate and has the same problems.<sup>130</sup> A combination (Mesigyna, Norigynon, Noristerat, Norigest, NET-EN) of norethindrone enanthate (50 mg) with estradiol valerate (5 mg) given monthly provides effective contraception with good cycle control.<sup>265</sup> Compared with Lunelle, this combination has less bleeding problems.<sup>266</sup> Fertility returns rapidly (by 1 month) after discontinuation.<sup>262</sup>

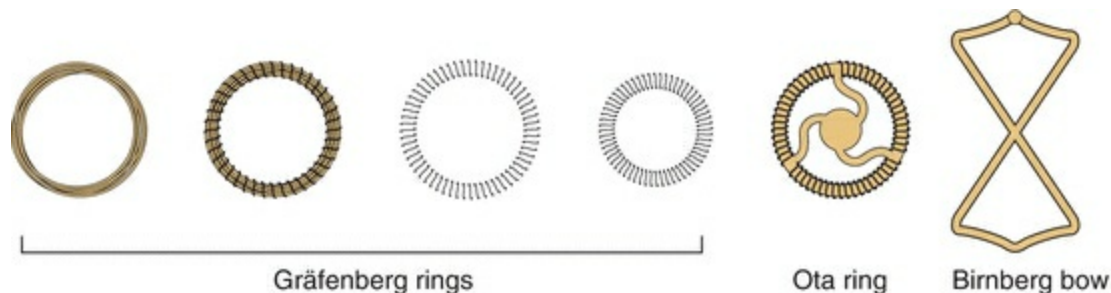


# **Dihydroxyprogesterone      Acetophenide      and Estradiol Enanthate**

The combination of 150 mg dihydroxyprogesterone acetophenide with 10 mg estradiol enanthate (various brand names) is the most widely used injectable contraceptive in Latin America. As with Lunelle and the norethindrone combination, the monthly regimen allows regular, and even reduced, cyclic bleeding.<sup>267</sup> A lower dose (90 mg dihydroxyprogesterone acetophenide and 6 mg estradiol enanthate) provides the same effective contraception as the higher dose with similar bleeding patterns.<sup>268</sup>

# INTRAUTERINE DEVICES

The forerunners of the modern IUD were small stem pessaries used in the 1800s that covered the opening of the cervix and were attached to stems extending into the cervical canal.<sup>269</sup> In 1902, a pessary that extended into the uterus was developed by Hollweg in Germany and used for contraception. This pessary was sold for self-insertion, but the hazard of infection was great, earning the condemnation of the medical community. In 1909, Richter, in Germany, reported success with a silkworm catgut ring that had a nickel and bronze wire protruding through the cervix.<sup>270</sup> Shortly after, Pust combined Richter's ring with the old button-type pessary and replaced the wire with a catgut thread.<sup>271</sup> This IUD was used during World War I in Germany, although the German literature was quick to report infections with its insertion and use. In the 1930s, Gräfenberg reported removing the tail and pessary because he believed this was the cause of infection, using rings made of coiled silver and gold and then steel (**Figure 23.6**).<sup>272</sup> The Gräfenberg ring was associated with a high rate of expulsion. This was solved by Ota in Japan who added a supportive structure to the center of his gold- or silver-plated ring in 1934.<sup>273</sup> During World War II, Gräfenberg and Ota fell victim to Nazi political philosophy that was bitterly opposed to contraception.



**FIGURE 23.6**

An awareness of the explosion in population and its impact began to grow in the first two decades after World War II. In 1959, reports from Japan and Israel by Ishihama and Oppenheimer once again stirred interest in the rings.<sup>274,275</sup> The Oppenheimer report was in the *American Journal of Obstetrics and Gynecology*, and several American gynecologists began to use rings of silver or silk, and others to develop their own devices.

In the 1960s and 1970s, the IUD thrived. Techniques were modified, and new types made of new materials, such as polyethylene impregnated with barium sulfate for x-ray opacity, were introduced. The Margulies Coil, developed by Lazer Margulies in 1960 at

Mt. Sinai Hospital in New York City, was the first plastic device with a memory, which allowed the use of an inserter and reconfiguration of the shape when it was expelled into the uterus. The coil was a large device (sure to cause cramping and bleeding), and its hard plastic tail proved risky for the male partner.

In 1962, the Population Council, at the suggestion of Alan Guttmacher, who that year became president of the Planned Parenthood Federation of America, organized the first international conference on IUDs in New York City. This conference led to the organization of a program to evaluate IUDs, the Cooperative Statistical Program. The Ninth Progress Report in 1970 was a landmark comparison of efficacy and problems with the various IUDs in use.<sup>276</sup>

It was at this 1962 conference that Jack Lippes presented experience with his device, which had a novel single filament thread as a tail to establish position and for easy removal. The Margulies Coil was rapidly replaced by the Lippes loop. Acquired by the Ortho Pharmaceutical Corporation in 1966, it quickly became the most widely prescribed IUD in the United States. The Population Council acquired international rights for the Lippes loop, and it became used by millions of women throughout the world.

The Dalkon Shield was introduced in 1970. Within 3 years, a high incidence of pelvic infection was recognized. There is no doubt that the problems with the Dalkon Shield were due to defective construction—the multifilamented tail provided a pathway for bacteria to ascend protected from the cervical mucous barrier.<sup>277</sup> Although sales were discontinued in 1975, a call for removal of all Dalkon Shields was not issued until the early 1980s. The large number of women with pelvic infections led to many lawsuits against the pharmaceutical company, ultimately causing its bankruptcy. Unfortunately, the Dalkon Shield problem tainted all IUDs, and for a long time, media and the public in the United States inappropriately regarded all IUDs in a single, generic fashion. Making the situation worse, changes in sexual behavior in the 1960s and 1970s, and failure to use infection preventing contraceptives (condoms and oral contraceptives), led to an epidemic of STIs and PID for which IUDs were held partially responsible.<sup>278</sup>

The first epidemiologic studies of the relationship between IUDs and PID used women who depended on oral contraception or barrier methods as controls and who were, therefore, at reduced risk of PID compared with noncontraceptors and IUD users.<sup>279,280</sup> In addition, these first studies failed to control for the characteristics of sexual behavior that are now accepted as risk factors for PID (multiple partners, early age at first intercourse, and increased frequency of intercourse).<sup>281</sup> The Dalkon Shield magnified the risk attributed to IUDs because its high failure rate in young women who were already at risk of STIs led to septic spontaneous abortions and, in some cases, death.<sup>282</sup> Reports of these events led the American public to regard all IUDs as

dangerous, including those that, unlike the Dalkon Shield, had undergone extensive clinical trials and postmarketing surveillance.

The 1980s saw the decline of IUD use in the United States as manufacturers discontinued marketing in response to the burden of litigation. The final blow to the IUD in the United States came in 1985 with the publication of two reports indicating that the use of IUDs was associated with tubal infertility.<sup>283,284</sup> Despite the fact that most of the lawsuits against the copper devices were won by the manufacturer, the cost of the defense combined with declining use affected the financial return.

Americans remained averse to IUDs even after better controlled studies that identified the Dalkon Shield as a high-risk device and failed to demonstrate an association between PID and other IUDs were published. Efforts to point out that the situation was different for the copper IUDs, and that, in fact, PID was not increased in women with a single sexual partner,<sup>285</sup> failed to prevent the withdrawal of IUDs from the American market and the negative reaction to IUDs by the American public. The number of reproductive-age women using the IUD in the United States decreased by two-thirds from 1982 to 1988 and further decreased in 1995, from 7.1% to 2% to 0.8%, respectively.<sup>286</sup> Since 1995, the use of the IUD in the United States has climbed to 6.4% of all women, or 10.3% of all women using contraceptives, reflecting the popularity of the levonorgestrel-releasing system.<sup>287</sup> In the rest of the world, the IUD is the most widely used method of reversible contraception, currently, with 13.5% of reproductive-age women using an IUD for contraception<sup>1</sup> (Table 23.6).

## **TABLE 23.6 Use of the IUD in the United States and China**

	<b>United States</b>	<b>China</b>	<b>Total World</b>
1981	4.8 million women	34.9 million	60 million
1991	1.0 million women	33.1 million	83 million
2001	1.9 million women	39.6 million	106 million
2010	8.9 million women	40.6 million	>180 million

# THE MODERN IUD

---

The addition of copper to the IUD was suggested by Jaime Zipper of Chile, whose experiments with metals indicated that copper acted locally on the endometrium.<sup>288</sup> Howard Tatum in the United States combined Zipper's suggestion with the development of the T-shape, which he felt would conform better to the shape of the uterus, and produced the copper-T. The first copper IUD had copper wire wound around the straight shaft of the T, the TCu-200 (200 mm<sup>2</sup> of exposed copper wire), also known as the Tatum-T.<sup>289</sup> The copper IUDs could be much smaller than those of simple, inert plastic devices and still provide effective contraception. Studies indicate that copper exerts its effect before implantation of a fertilized ovum; it may be spermicidal, or it may diminish sperm motility or fertilizing capacity. The addition of copper to the IUD and reduction in the size and structure of the frame improved tolerance, resulting in fewer removals for pain and bleeding.

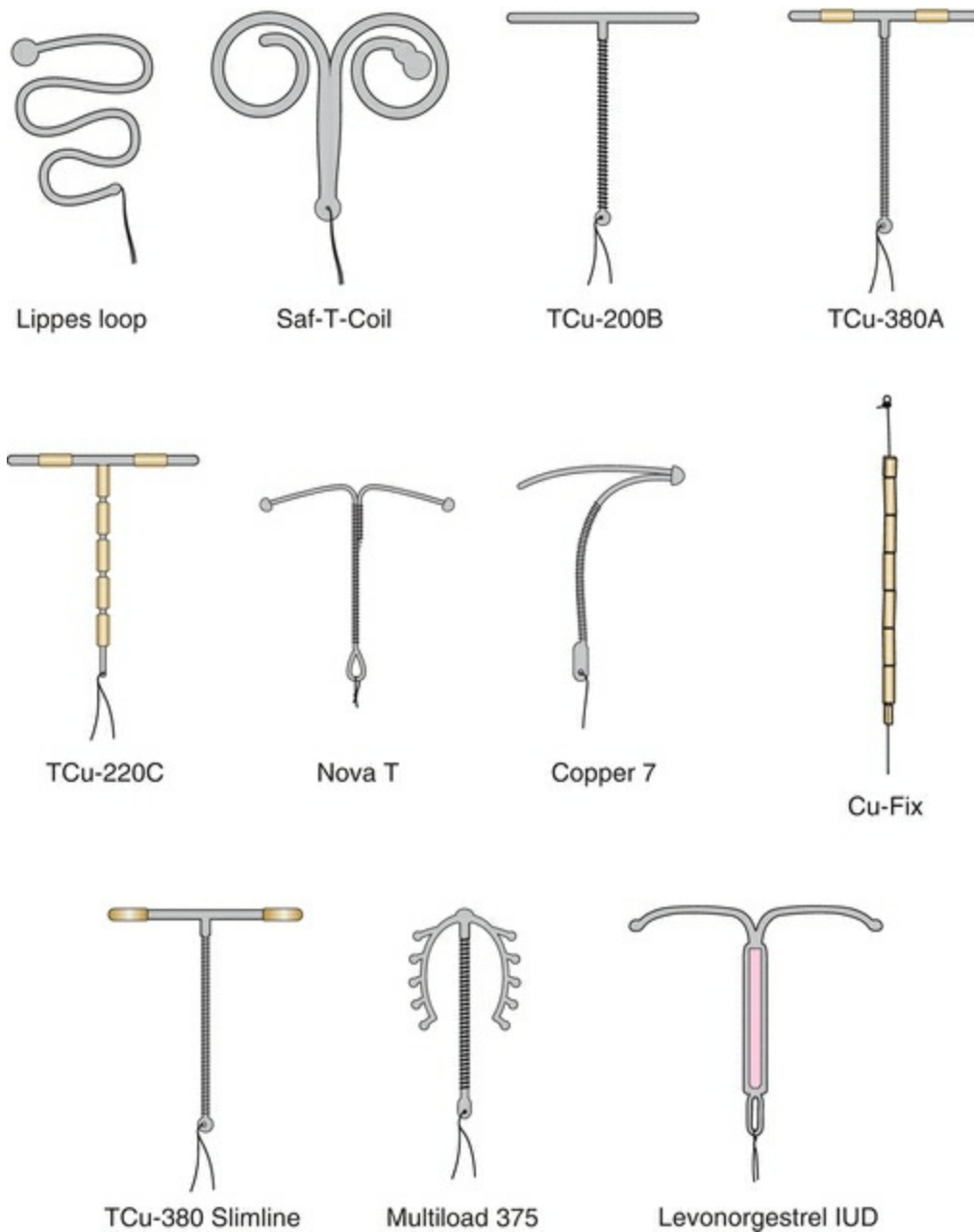
The Cu-7 with a copper wound stem was developed in 1971 and quickly became the most popular device in the United States. Both the Cu-7 and the Tatum-T were withdrawn from the US market in 1986 by G.D. Searle and Company. IUD development continued, however. More copper was added by Population Council investigators, leading to the TCu-380A (380 mm<sup>2</sup> of exposed copper surface area) with copper wound around the stem plus a copper sleeve on each horizontal arm.<sup>290</sup> The "A" in TCu-380A is for arms, indicating the importance of the copper sleeves. Making the copper solid and tubular increased effectiveness and the life span of the IUD. The TCu-380A has been in use in more than 30 countries since 1982, and, in 1988, it was marketed in the United States as the "ParaGard."

# TYPES OF IUDS

---

# Unmedicated IUDs

The Lippes loop, made of plastic (polyethylene) impregnated with barium sulfate, is still used throughout the world (except in the United States). Flexible stainless steel rings were widely used in China but not elsewhere until 1994 when copper IUDs were mandated (Figure 23.7).<sup>291, 292</sup>



**FIGURE 23.7**



# Copper IUDs

The first copper IUDs were wound with 200–250 mm<sup>2</sup> surface area of wire, and two of these are still available (except in the United States): the TCU-200 and the Multiload-250. The more modern copper IUDs contain more copper, and part of the copper is in the form of solid tubular sleeves, rather than wire, increasing efficacy and extending life span. This group of IUDs is represented in the United States by the TCU-380A (the ParaGard) and in the rest of the world by the TCU-220C, the Nova T, and the Multiload-375. The Sof-T is a copper IUD used only in Switzerland.

The TCU-380A is a T-shaped device with a polyethylene frame holding 380 mm<sup>2</sup> of exposed surface area of copper that provides contraception for at least 10 years. Although the data are sparse, wearing the TCU-380A for 20 years carries only a very small risk of pregnancy.<sup>293</sup> The pure electrolytic copper wire wound around the 36-mm stem weighs 176 mg, and copper sleeves on the horizontal arms weigh 66.5 mg. A polyethylene monofilament is tied through the 3-mm ball on the stem, providing two white threads for detection and removal. The ball at the bottom of the stem helps reduce the risk of cervical perforation. The IUD frame contains barium sulfate, making it radiopaque. The TCU-380Ag is identical to the TCU-380A, but the copper wire on the stem has a silver core to prevent fragmentation and extend the lifespan of the copper. The TCU-380 Slimline has the copper sleeves flush at the ends of the horizontal arms to facilitate easier loading and insertion. The performance of the TCU-380Ag and the TCU-380 Slimline is equal to that of the TCU-380A.<sup>294 295</sup>

The Multiload-375 has 375 mm<sup>2</sup> of copper wire wound around its stem. The flexible arms were designed to minimize expulsions. This is a popular device in many parts of the world. The Multiload-375 and the TCU-380A are similar in their efficacy and performance.<sup>296</sup>

The Nova T is similar to the TCU-200, containing 200 mm of copper; however, the Nova T has a silver core to the copper wire, flexible arms, and a large, flexible loop at the bottom to avoid injury to cervical tissue. There was some concern that the efficacy of the Nova T decreased after 3 years in World Health Organization (WHO) data; however, results from Finland and Scandinavia indicate low and stable pregnancy rates over 5 years of use.<sup>296</sup>

The CuSAFE-300 IUD has 300 mm<sup>2</sup> of copper in its vertical arm and a transverse arm with sharply bent ends that are adapted to the uterine cavity and help hold this IUD in the fundus. It is made from a more flexible plastic and is smaller than the world's two most popular IUDs, the TCU-380A and the Multiload-375. Pregnancy rates with the CuSAFE-300 are comparable to these two devices, but rates of removal for pain and

bleeding are reported to be lower.<sup>297</sup>

# Hormone-Releasing IUDs

The LNG-IUS 20 (levonorgestrel-releasing intrauterine system, Mirena), manufactured by Bayer, in vitro releases 20 mcg of levonorgestrel per day.<sup>298</sup> This T-shaped device has a collar attached to the vertical arm, which contains 52 mg levonorgestrel dispersed in polydimethylsiloxane and released initially at a rate of 20 mcg/day in vivo, progressively declining (reaching half of the initial rate after 5 years). It is 32 mm long, the arm span is 32 mm wide, and the diameter of its insertion tube is 4.4 mm. The Mirena IUS is approved for 5 years, but lasts for 7 years, and perhaps up to 10 years, and reduces menstrual blood loss and pelvic infection rates.<sup>299, 300, 301</sup>

The Mirena is about as effective as endometrial ablation for the treatment of menorrhagia.<sup>302, 303</sup> The local progestin effect directed to the endometrium can be utilized in patients on tamoxifen,<sup>304</sup> in patients with dysmenorrhea,<sup>305</sup> and in postmenopausal women receiving estrogen therapy.<sup>306, 307, 308, 309, 310, 311</sup>

In the United States, three other levonorgestrel IUSs are available—the Liletta, which has 52 mg of levonorgestrel and is effective as contraception for up to 4 years; the Kyleena (LNG-IUS 12), which has 19.5 mg of levonorgestrel and is effective as contraception for up to 5 years; and the Skyla (LNG-IUS 8), which has 13.5 mg of levonorgestrel and is effective as contraception for up to 3 years. The Liletta releases 19.5 mcg/day of levonorgestrel, which decreases to 11.3 mcg/day by the 4th year of use and was FDA approved in 2015.<sup>312</sup> It also measures 32 mm long and its arms are 32 mm wide, but it has a cost advantage over the Mirena system. The Kyleena releases 17 mcg/day of levonorgestrel, which decreases to 7.4 mcg/day after 5 years and was FDA approved in 2016.<sup>312</sup> The Skyla releases 14 mcg/day of levonorgestrel, which decreases to 5 mcg/day after 3 years and was FDA approved in 2013.<sup>313</sup> The Kyleena and Skyla IUSs are smaller than the Mirena, and their insertion tubes are 3.8 mm in diameter, making them desirable for nulliparous patients. They are both manufactured by Bayer, like the Mirena IUS, but are indicated for contraception only.

A slightly smaller T-shaped device that releases 20 mg of levonorgestrel daily is called the Femilis LNG-IUS.<sup>314</sup> Smaller devices releasing 5 or 10 mcg levonorgestrel have been developed in Europe for use for at least 5 years in postmenopausal women.<sup>310</sup>

## Other IUDs

The Ombrelle-250 and Ombrelle-380, designed to be more flexible in order to reduce expulsion and side effects, have been marketed in France. A frameless IUD, the FlexiGard (also known as the Cu-Fix or the GyneFIX), invented by Dirk Wildemeersch in 1983 in Belgium, consists of six copper sleeves (330 mm<sup>2</sup> of copper) strung on a surgical nylon (polypropylene) thread that is knotted at one end. The knot is pushed into the myometrium during insertion with a notched needle that works like a miniature harpoon. Because it is frameless, it has a low rate of removal for bleeding or pain, but a more difficult insertion may yield a higher expulsion rate. However, when inserted by experienced clinicians, the expulsion rate is very low, and the device is especially suited for nulligravid and nulliparous women.<sup>315, 316, 317</sup> This IUD is increasingly popular in Europe. A shorter system combined with a reservoir for the sustained release of 14 mcg levonorgestrel per day (FibroPlant) is being tested for perimenopausal and postmenopausal use.<sup>318, 319</sup> FibroPlant effectively treats endometrial hyperplasia and menorrhagia.<sup>320, 321</sup>

# Mechanism of Action

The contraceptive action of all IUDs is mainly in the uterine cavity. Ovulation is not affected, and the IUD is not an abortifacient, even when used as emergency contraception.<sup>322, 323, 324, 325</sup> It is currently believed that the mechanism of action for IUDs is the production of an intrauterine environment that is spermicidal.

Nonmedicated IUDs depend for contraception on the general reaction of the uterus to a foreign body. It is believed that this reaction, a sterile inflammatory response, produces tissue injury of a minor degree but sufficient enough to be spermicidal. Very few, if any, sperm reach the ovum in the fallopian tube. Normally cleaving, fertilized ova cannot be obtained by tubal flushing in women with IUDs in contrast to noncontraceptors, indicating the failure of sperm to reach the ovum, and, thus, fertilization does not occur.<sup>326</sup> In women using copper IUDs, sensitive assays for human chorionic gonadotropin (hCG) do not find evidence of fertilization.<sup>327, 328</sup> This is consistent with the fact that the copper IUD protects against both intrauterine and ectopic pregnancies.

The copper IUD releases free copper and copper salts that have both a biochemical and morphologic impact on the endometrium, enhancing prostaglandin production, producing cytotoxic cytokine peptides, and inhibiting endometrial enzymes.<sup>329</sup> Endometrial receptivity is inhibited. An additional spermicidal effect probably takes place in the cervical mucus. There is no measurable increase in the serum copper level.

The progestin-releasing IUD adds the endometrial action of the progestin to the foreign body reaction. The endometrium becomes decidualized with atrophy of the glands.<sup>330</sup> The progestin IUD probably has two mechanisms of action: inhibition of implantation and inhibition of sperm capacitation, penetration, and survival. The levonorgestrel IUS produces serum concentrations of the progestin about half those of Norplant so that ovarian follicular development and ovulation are also partially inhibited; after the 1st year, cycles are ovulatory in 50–75% of women, regardless of their bleeding patterns.<sup>331</sup> Finally, the progestin IUD thickens the cervical mucus, creating a barrier to sperm penetration.

Following removal of IUDs, the normal intrauterine environment is rapidly restored. **In large studies, there is no delay, regardless of duration of use, in achieving pregnancy at normal rates, which belies the assertion that IUD use is associated with infection leading to infertility.**<sup>332, 333</sup> There has been no significant difference in cumulative pregnancy rates between parous and nulliparous or nulligravid women.<sup>334, 335</sup>

The levonorgestrel IUS may be associated with a slight increase in the formation of

ovarian cysts, but they are asymptomatic and resolve spontaneously.<sup>336</sup> An increase in the risk of venous thrombosis has not been observed in users of the levonorgestrel IUS.<sup>337</sup>

# Noncontraceptive Benefits with the Levonorgestrel IUS 20

Because of the favorable impact of locally released progestin on the endometrium, the Mirena IUS is very effective for the treatment of menorrhagia; is more effective than the administration of oral progestins, steroid contraceptives, or inhibitors of prostaglandin synthesis; and compares favorably with surgical treatment (hysterectomy or endometrial ablation).<sup>303, 338, 339, 340, 341, 342, 343, 344, 345, 346, 347</sup>

The Mirena IUD rapidly decreases dysmenorrhea and menstrual blood loss (about 40–50%). Bleeding over time can be reduced by 90% and about 30–40% of women become amenorrheic 1 year after insertion.<sup>348, 349</sup> The LNG-IUS 12 is also associated with decreased bleeding, with 22.6% of women becoming amenorrheic and many women reporting less blood loss than before placement.<sup>350</sup> LNG-IUS 8 users report significant decreases in instances of heavy or prolonged bleeding, and 10.8% of women became amenorrheic prior to removal.<sup>351</sup> For the Mirena, average long-term hemoglobin and iron levels increase compared with preinsertion values.<sup>352</sup>

Bleeding is even reduced in the presence of leiomyomas.<sup>295, 353, 354, 355, 356</sup> There is some evidence that the Mirena reduces the prevalence of myomas and the uterine volume in the presence of myomas.<sup>352, 354, 355, 356</sup> Not all women with myomas respond favorably to the levonorgestrel IUS; this is usually because of the presence of submucosal myomas.<sup>357</sup> The Mirena also effectively reduces uterine volume and relieves dysmenorrhea secondary to adenomyosis.<sup>358, 359, 360, 361</sup>

Women with hemostatic disorders, such as von Willebrand disease, and women who are anticoagulated commonly have heavy menstrual bleeding. The insertion of the Mirena effectively reduces the amount of bleeding in many, but not all, of these patients, and there is a suggestion that with time the beneficial effect wanes and earlier replacement is necessary.<sup>362, 363, 364, 365, 366</sup>

In a randomized, 5-year trial comparing a copper IUD with the Mirena, pelvic infection was lower than the incidence in a general population with both devices, but the rate with the levonorgestrel IUS was significantly lower compared with the copper IUD.<sup>367</sup>

The Mirena has been used successfully to treat endometriosis and especially dysmenorrhea associated with endometriosis.<sup>37, 38, 305, 368, 369, 370</sup> Results may even be comparable to those obtained with GnRH agonist treatment.<sup>371</sup> The advantages of Mirena treatment of endometriosis include many years of efficacy, fewer side effects, and contraception.

The Mirena effectively protects the endometrium against hyperplasia and polyps in women using tamoxifen or postmenopausal estrogen therapy.<sup>304, 306, 307, 308, 309, 310, 372, 373, 374</sup> In addition, this IUD can be used to treat endometrial hyperplasia.<sup>320, 375, 376, 377, 378, 379</sup> Comparison studies indicate that the Mirena is as effective and probably better than standard treatment with an oral progestin.<sup>376, 380, 381</sup> **However, the persistence of atypia at biopsy follow-up after 6 months is an indication that regression is unlikely to occur.**

**Although the Mirena IUD confidently provides good protection against endometrial hyperplasia, clinicians should maintain a high degree of suspicion of unusual bleeding (bleeding that occurs after a substantial period of amenorrhea) and aggressively assess the endometrium.** Endometrial adenocarcinoma has been identified in users of the levonorgestrel IUS; rates of persistent disease may be as high as 14.3% of those treated for 6 months.<sup>382, 383, 384</sup> As noted however, many studies have documented protection against and even regression of endometrial hyperplasia.

## Key Points: Noncontraceptive Benefits with the Mirena

- Reduction of heavy menstrual bleeding and improvement of related anemia.
- Treatment of primary dysmenorrhea.
- Reduction of myoma prevalence as well as uterine volume and bleeding associated with myomas.
- Decrease in uterine volume and pain associated with adenomyosis.
- Reduction of menstrual bleeding in women with hemostatic disorders and in anticoagulated women.
- Protection against PID.
- Treatment of endometriosis and pain associated with endometriosis.
- Suppression of endometriosis.
- Protection against endometrial hyperplasia and polyps associated with postmenopausal estrogen therapy or tamoxifen treatment.
- Prevention of ectopic pregnancy.
- Reduction of endometrial cancer risk.



## Efficacy of IUDs

The TCU-380A is approved for use in the United States for 10 years. However, the TCU-380A has been demonstrated to maintain its efficacy over at least 12 years of use.<sup>385</sup> As previously noted, based on a small number of long-term users, wearing the TCU-380A for 20 years carries a very small risk of pregnancy.<sup>293</sup> The TCU-200 is approved for 4 years and the Nova T for 5 years. The Mirena IUD can be used for at least 7 years and probably for 10 years.<sup>295, 386</sup> The levonorgestrel device that releases 15–20 mg levonorgestrel per day is as effective as the copper IUDs that contain more than 250 mm<sup>2</sup> of copper surface area.<sup>34, 295, 299, 387</sup>

The nonmedicated IUDs never have to be replaced. The deposition of calcium salts on the IUD can produce a structure that is irritating to the endometrium. If bleeding increases after a nonmedicated IUD has been in place for some time, it is worth replacing it. Some clinicians (as do we) recommend replacing all older IUDs with the new, more effective medicated IUDs ([Table 23.7](#)).

### **TABLE 23.7 First Year Clinical Trial Experience in Parous Women**

Device	Pregnancy Rate (%)	Expulsion Rate (%)	Removal Rate (%)
Lippes loop	3	12–20	12–15
Cu-7	2–3	6	11
TCu-200	3	8	11
TCU-380A	0.5–0.8	5	14
Levonorgestrel IUS	0.2	6	17

Considering all IUDs together, the actual use failure rate in the 1st year is approximately 3%, with a 10% expulsion rate and a 15% rate of removal, mainly for bleeding and pain. With increasing duration of use and increasing age, the failure rate decreases, as do removals for pain and bleeding. The performance of the TCU-380A in recent years, however, has proved to be superior to previous IUDs ([Table 23.8](#)).

**TABLE 23.8 Ten-Year Experience with Paragard, TCU-380A Rate Per 100 Users Per Year**

	Year									
	1	2	3	4	5	6	7	8	9	10
Pregnancy	0.7	0.3	0.6	0.2	0.3	0.2	0.0	0.4	0.0	0.0
Expulsion	5.7	2.5	1.6	1.2	0.3	0.0	0.6	1.7	0.2	0.4
Bleeding/pain removal	11.9	9.8	7.0	3.5	3.7	2.7	3.0	2.5	2.2	3.7
Medical removals	2.5	2.1	1.6	1.7	0.1	0.3	1.0	0.4	0.7	0.3
Continuation	76.8	78.3	81.2	86.2	89.0	91.9	87.9	88.1	92.0	91.8
Number starting each year	4,932	3,149	2,018	1,121	872	621	563	483	423	325

Data from **Sivin I, el Mahgoub S, McCarthy T, Mishell DR Jr, Shoupe D, Alvarez F, Brache V, Jimenez E, Diaz J, Faundes A, Diaz MM, Coutinho E, Mattos CER, Diaz S, Pavez M, Stern J**, Long-term contraception with the levonorgestrel 20 mcg/day (LNg 20) and the copper T 380Ag intrauterine devices: a five-year randomized study, *Contraception* 42:361, 1990; **Meirik O, Farley TMM, Sivin I; International Collaborative Post-Marketing Surveillance of Norplant**, Safety and efficacy of levonorgestrel implant, intrauterine device, and sterilization, *Am J Obstet Gynecol* 97:539, 2001; **Sivin I, Schmidt F**, Effectiveness of IUDs: a review, *Contraception* 36:55, 1987.

In careful studies, with attention to technique and participation by motivated patients, the failure rate with the TCu-380A is less than 1 per 100 women per year.<sup>296, 388, 389</sup> The cumulative net pregnancy rate after 7 years of use is 1.5 per 100 woman-years, and after 12 years, only 1.9 per 100 women (not a single pregnancy was reported after 8 years of use).<sup>385, 390</sup> In developing countries, the failure rate with IUDs is less than that with oral contraception.<sup>391</sup> Failure rates are slightly higher in younger (< age 25), more fertile women.

Women use IUDs longer than other reversible methods of contraception. The IUD continuation rate is higher than that with oral contraception, condoms, or diaphragms. This may reflect the circumstances surrounding the choice of an IUD (older, parous women).

# Expulsion

Approximately 5% of patients spontaneously expel the TCu-380A within the 1st year. Women younger than age 20 have a higher expulsion rate than older women.<sup>300, 392</sup> In a nulligravid, adolescent population, the cumulative expulsion rate with the Mirena system was 8%.<sup>393</sup> In a population of parous and nulliparous women with the Kyleena, the cumulative 5-year expulsion rate was 3.7%.<sup>350</sup> This event can be associated with cramping, vaginal discharge, or uterine bleeding. However, in some cases, the only observable change is lengthening or absence of the IUD strings. Patients should be cautioned to request immediate attention if expulsion is suspected. A partially expelled IUD should be removed. If pregnancy or infection is not present, a new IUD can be inserted immediately (in this instance, antibiotic prophylaxis is recommended).<sup>394</sup>


# Ectopic Pregnancy

The previous use of an IUD does not increase the risk of a subsequent ectopic pregnancy.<sup>335, 397, 398</sup> The current use of an IUD offers some protection against ectopic pregnancy.<sup>350, 395, 396, 397, 398, 399, 400</sup> The largest study, a WHO multicenter study, concluded that IUD users were 50% less likely to have an ectopic pregnancy when compared with women using no contraception.<sup>395</sup> This protection is not as great as that achieved by inhibition of ovulation with oral contraception. **Therefore, when an IUD user becomes pregnant, the pregnancy is more likely to be ectopic. However, the actual occurrence of an ectopic pregnancy in an IUD user is a rare event.**

The lowest ectopic pregnancy rates are seen with the most effective IUDs, like the TCu-380A (90% less likely compared with noncontraceptors).<sup>401</sup> The rate is about one-tenth of the ectopic pregnancy rate associated with the Lippes loop or with devices with less copper such as the TCu-200.<sup>401</sup> Very few ectopic pregnancies have been reported with levonorgestrel IUSs. In an 18-month study of 279 women who had a Skyla placed, 1 ectopic pregnancy was reported (of 2 pregnancies total).<sup>402</sup> With the Kyleena, a 5-year Pearl Index for ectopic pregnancy of 0.18 is reported.<sup>350</sup> In a 3-year study of 1,714 women with the Liletta, 4 ectopic pregnancies occurred (of 6 pregnancies total).<sup>403</sup> With the Mirena, a study reported the 5-year pregnancy rate for users was 0.5 per 100, and 53% of these pregnancies were ectopic.<sup>404</sup> The risk of ectopic pregnancy does not increase with increasing duration of use with the TCu-380A or the Mirena IUS.<sup>293, 390</sup> In a 7-year prospective study, not a single ectopic pregnancy was encountered with the levonorgestrel IUS, and in a 5-year study, only one.<sup>295, 367</sup> In 8,000 woman-years of experience in randomized multicenter trials, there was only a single ectopic pregnancy reported with the TCu-380A (which is one-tenth the rate with the Lippes loop or TCu-200).<sup>293</sup> Therefore, the risk of ectopic pregnancy during the use of the copper IUD or the levonorgestrel IUSs is much lower compared with noncontraceptive users; however, if pregnancy occurs, the likelihood of an ectopic pregnancy is high.<sup>404</sup>

**The protection against ectopic pregnancy provided by the TCu-380A and the levonorgestrel IUS makes these IUDs acceptable choices for contraception in women with previous ectopic pregnancies (Table 23.9).**

## TABLE 23.9 Ectopic Pregnancy Rates per 1,000 Woman-Years



Non contraceptive users, all ages	3.00–4.50
-----------------------------------	-----------

---

Levonorgestrel IUS	0.20
--------------------	------

---

TCu-380A IUD	0.20
--------------	------

---

Data from **Franks AL, Beral V, Cates W Jr, Hogue CJ**, Contraception and ectopic pregnancy risk, *Am J Obstet Gynecol* 163:1120, 1990; **Sivin I**, Dose- and age-dependent ectopic pregnancy risks with intrauterine contraception, *Obstet Gynecol* 78:291, 1991.

## Side Effects

With effective patient screening and good insertion technique, the copper and levonorgestrel IUDs are not associated with an increased risk of infertility after their removal.<sup>405</sup> Even if IUDs are removed for pain or abnormal bleeding, subsequent fertility rates are normal.<sup>34,332,333</sup> Within 1 year, 5–15% of women discontinue IUDs because of these problems. Smaller copper and progestin IUDs have reduced the incidence of pain and bleeding considerably, but a careful menstrual history is still important in helping a woman consider an IUD. Women with prolonged, heavy menstrual bleeding or significant dysmenorrhea may not be able to tolerate copper IUDs but may benefit from a progestin IUD.<sup>339,340,341</sup> Because bleeding and cramping are most severe in the first few months after IUD insertion, treatment with a nonsteroidal anti-inflammatory drug (NSAID, an inhibitor of prostaglandin synthesis) during the first several menstrual periods can reduce bleeding and cramping. Even persistent heavy menses can be effectively treated with NSAIDs.<sup>406</sup> NSAID treatment should begin at the onset of menses and be maintained for 3 days. A copper IUD is available in China that also releases a small amount of indomethacin; this device is associated with markedly less bleeding.<sup>407</sup> It is not unusual to have a few days of intermenstrual spotting or light bleeding. Although aggravating, this does not cause significant blood loss. New-onset intermenstrual bleeding deserves the usual evaluation for cervical or endometrial pathology. These changes can be objectionable for women who are prevented from having intercourse while bleeding.

Following insertion of a modern copper IUD, menstrual blood loss increases by about 55%, and menstruation is prolonged 1–2 days, symptoms that continue for the duration of IUD use.<sup>408</sup> Over a year's time, this amount of blood loss does not result in changes indicative of iron deficiency (e.g., serum ferritin). With longer use, however, ferritin levels are lower, suggesting a depletion of iron stores.<sup>409</sup> Assessment for iron depletion and anemia should be considered in long-term users and in women susceptible to iron deficiency anemia. In populations with a high prevalence of anemia, these changes occur more rapidly, and iron supplementation is recommended.<sup>410</sup>

Because of a decidualizing, atrophic impact on the endometrium, amenorrhea can develop over time with the progestin-containing IUD. With the Mirena IUS, 70% of patients are oligomenorrheic and 30–40% are amenorrheic within 2 years.<sup>348,411</sup> In a group of women who used the levonorgestrel IUS for more than 12 years, 60% were amenorrheic; 12% experienced infrequent, scanty bleeding; and 28% had regular but light bleeding.<sup>349</sup> For some women, the lack of periods is so disconcerting that they request removal. On the other hand, this effect on menstruation is manifested by an increase in blood hemoglobin levels.<sup>298,387</sup>

Sufficient progestin reaches the systemic circulation from the levonorgestrel-containing IUS so that androgenic side effects, such as acne and hirsutism, can occur; however, in one study, no change could be detected in the circulating levels of SHBG, and, therefore, marked clinical effects are unlikely.<sup>412</sup> Occasionally a patient will experience facial, androgenic skin changes or breast tenderness. Spironolactone treatment for androgenic reactions (discussed in [Chapter 12](#)) is effective and can be titrated down to the lowest successful dose. There are no significant metabolic effects, including changes in glucose, insulin sensitivity, and lipids.<sup>413</sup> In a large postmarketing survey, the incidence of breast cancer in users of the levonorgestrel system was equivalent to that in the general population.<sup>414</sup> The combination of the levonorgestrel system and estrogen therapy in postmenopausal women did not increase breast density.<sup>415</sup>

Some women report an increased vaginal discharge while wearing an IUD. This complaint deserves examination for the presence of vaginal or cervical infection. Treatment can be provided with the IUD remaining in place.

Long-term use of the IUD is associated with impressive safety and lack of side effects. In a 7-year prospective study, the use of either the copper IUD or the levonorgestrel IUS beyond 5 years led to no increase in pelvic infection, no increase in ectopic pregnancy rates, no increase in anemia, and no increase in abnormal Pap smears.<sup>299</sup> Duration of use does not affect pregnancy rates or outcome.

The presence of copper may yield some benefits. There are epidemiologic data indicating that both the copper IUD and the inert IUD reduce the risks of endometrial cancer and invasive cervical cancer.<sup>418,419,420,421,422,423</sup> Presumably, this protective effect is due to induced biochemical alterations that affect cellular responses.

The copper IUD is not affected by magnetic resonance imaging, and therefore, the copper IUD need not be removed before MRI, and neither patients nor workers need be excluded from MRIs or the MRI environment.<sup>422,423</sup>

## Infections

IUD-related bacterial infection is due to contamination of the endometrial cavity at the time of insertion. Mishell's classic study indicated that the uterus is routinely contaminated by bacteria at insertion.<sup>424</sup> Infections that occur 3–4 months after insertion are believed to be due to acquired STIs, not the direct result of the IUD. The early, insertion-related infections, therefore, are polymicrobial and are derived from the endogenous cervicovaginal flora, with a predominance of anaerobes.

A review of the World Health Organization database derived from all of the WHO IUD clinical trials concluded that the risk of PID was six times higher during the 20



days after the insertion compared with later times during follow-up, but, most importantly, PID was extremely rare beyond the first 20 days after insertion.<sup>425</sup> In nearly 23,000 insertions, only 81 cases of PID were diagnosed. There was no statistically significant difference comparing the copper IUD to the inert Lippes loop or progestin-containing IUD. However, evidence indicates that the levonorgestrel IUS may reduce pelvic infection rates.<sup>300,367</sup>

These data confirm earlier studies that the risk of infection with intrauterine contraception does not increase with long-term use.<sup>281,284</sup> The problem of infection can be minimized with careful screening and the use of aseptic technique. Even women with insulin-dependent diabetes mellitus do not have an increased risk for infection.<sup>426</sup> Women with Chlamydia infections at the time of insertion of a levonorgestrel or copper IUD are unlikely to develop PID if the infection is treated with the IUD left in place after a positive culture is obtained.<sup>427,428</sup> The copper IUD is associated with lower titers of antichlamydial antibody.<sup>301,365,429</sup> In vitro, copper inhibits chlamydial growth in endometrial cells.<sup>430</sup> Women who received IUDs in a population unrestricted by risks for STIs were not more likely than women in the general population to develop PID.<sup>431</sup> The association between IUD use and pelvic infection (and infertility) brought about by the Dalkon Shield is now debunked.<sup>432</sup> Women who use IUDs must be counseled to use condoms along with the IUD whenever they have intercourse with a partner who could be an STI carrier. Because sexual behavior is the most important modifier of the risk of infection, clinicians should ask prospective IUD users about numbers of partners, their partner's sexual practices, the frequency and age of onset of intercourse, and history of STIs.<sup>433</sup> Women at low risk are unlikely to have pelvic infections while using IUDs.<sup>285</sup> Women at high risk should be encouraged to also use condoms.

It was previously thought that the IUD may be inappropriate for women who are at increased risk of bacterial endocarditis (previous endocarditis, rheumatic heart disease, or the presence of prosthetic heart valves). The bacteriologic contamination of the uterine cavity at insertion is short-lived.<sup>424</sup> Only one study has shown blood culture evidence of bacteremia following IUD insertion, and it was present transiently in only a few patients.<sup>434</sup> A review of patients with cardiovascular conditions found no association between endocarditis and IUD placement.<sup>435,436</sup> IUD is a safe and effective option for patients at risk of endocarditis.

Asymptomatic IUD users whose cervical cultures show gonorrhea or chlamydia infection should be treated with the recommended drugs without removal of the IUD. If, however, there is evidence that an infection has ascended to the endometrium or fallopian tubes, treatment must be instituted and the IUD removed promptly. Vaginal bacteriosis should be treated (metronidazole, 500 mg b.i.d. for 7 days), but the IUD

need not be removed unless pelvic inflammation is present. There is no evidence that the prevalence of bacterial vaginosis is influenced by IUD use.<sup>437</sup>

For simple endometritis, in which uterine tenderness is the only physical finding, doxycycline (100 mg b.i.d. for 14 days) is adequate. If tubal infection is present, as evidenced by cervical motion tenderness, abdominal rebound tenderness, adnexal tenderness or masses, or elevated white blood count and sedimentation rate, parenteral treatment is indicated with removal of the IUD **as soon as antibiotic serum levels are adequate**. The previous presence of an IUD does not alter the treatment of PID. IUD-associated pelvic infection is more likely to be caused by non-STI organisms.<sup>438</sup>

#### **Appropriate outpatient management of less severe infections:**

- Cefoxitin (2 g intramuscularly) plus probenecid (1 g orally) as a single dose, plus doxycycline (100 mg b.i.d. orally), for 14 days
- Ceftriaxone (250 mg IM) plus doxycycline (100 mg b.i.d. orally), for 14 days

**Severe infections (those associated with pregnancy, nonadherence to therapy, pelvic abscesses, inability to take oral medications due to nausea or vomiting, or high fever) require hospitalization and treatment with:**

- Cefoxitin (2 g intravenous q.i.d.)
- Cefotetan (2 g intravenous b.i.d.)
- Plus doxycycline (100 mg b.i.d. orally or intravenous)
- Followed by 14 days of an oral regimen of antibiotics

#### **The following is an alternative regimen:**

- Clindamycin (900 mg intravenously t.i.d.)
- Plus gentamicin (2 mg/kg intravenously or intramuscularly followed by 1.5 mg/kg t.i.d.)

Regimens with levofloxacin are no longer recommended by the CDC, except in patients with a severe penicillin allergy who are also unable to take clindamycin or gentamicin. In those rare instances, a single dose of azithromycin 2 g should be given with 14 days of levofloxacin 500 mg.

There was a suggestion (in cross-sectional studies) that IUD use increased the risk of HIV transmission from man to woman, especially when the IUD was inserted or removed during exposure to the infected man.<sup>439,440</sup> However, this association was not strong, because the risk with IUD use was ascertained compared with other contraceptive methods (which can protect against transmission), and various influencing

factors are difficult to adjust and control. In the only longitudinal study, no association was observed between IUD use and HIV acquisition by women.<sup>441</sup> In the only study reported, no evidence for female-to-male HIV transmission with IUD use was detected.<sup>442</sup> HIV-infected women who utilize IUDs for contraception do not have a greater incidence of complications (including PID and disease progression), and genital shedding of HIV is not affected.<sup>443,444,445,446,447</sup>

Hepatitis C virus is believed to be transmitted with sexual contact. A cross-sectional study in Turkey indicated that IUD use by women in stable, monogamous relationships did not increase the incidence of hepatitis C seropositivity.<sup>448</sup>

## **Actinomyces**

The significance of actinomycosis infection in IUD users is unclear. There are many reports of IUD users with unilateral pelvic abscesses containing gram-positive Actinomyces.<sup>449,450,451,452</sup> However, Actinomyces are part of the normal flora in the gastrointestinal tract and were found in Pap smears of up to 30% of plastic IUD wearers when cytologists take special care to look for the organisms.<sup>452</sup> The rate is much lower (1–7%) with copper devices and the levonorgestrel-releasing intrauterine system and increases with duration of use.<sup>450,453,454,455,456</sup> Additionally, Actinomyces are present on cervical smears of 3% of women without IUDs.<sup>457</sup> Previous clinical practice recommended treating asymptomatic women with actinomyces noted on pap smear with oral penicillin or doxycycline. However, recent data support managing these women expectantly.<sup>458</sup> If the patient is due for IUD replacement, the IUD can be removed and a new one immediately inserted with no adverse effects.<sup>459</sup> If uterine tenderness or a pelvic mass is present, the IUD should always be removed after the initiation of treatment with oral penicillin G, 500 mg q.i.d. for 1 month. Alternative antibiotic regimens include tetracycline 500 mg q.i.d., doxycycline 100 mg b.i.d., and amoxicillin/clavulanate 500 mg b.i.d. Another anaerobic, gram-positive rod, Eubacterium nodatum, resembles Actinomyces and has also been reported to be associated with colonization of an IUD.<sup>460</sup> E. nodatum can be mistaken for Actinomyces on Pap smears. Our recommendations can be applied to both E. nodatum and Actinomyces.

# Pregnancy with an IUD In Situ

## Spontaneous Miscarriage

Spontaneous miscarriage occurs more frequently among women who become pregnant with IUDs in place, a rate of approximately 50%. Because of this high rate of spontaneous miscarriage, IUDs should always be removed if pregnancy is diagnosed and the string is visible. The use of instruments inside the uterus should be avoided if the pregnancy is desired, unless sonographic guidance can help avoid rupture of the membranes.<sup>461</sup> After removal of an IUD with visible strings, the spontaneous miscarriage rate is approximately 30%.<sup>462,463</sup> Combining ultrasonography guidance with carbon dioxide or saline hysteroscopy, an IUD with a missing tail can be identified and removed during early pregnancy.<sup>464,465</sup> **If the IUD is easily removed without trauma or expelled during the first trimester, the risk of spontaneous miscarriage is not increased.**<sup>466,467</sup>

## Septic Abortion

In the past, if the IUD could not be easily removed from a pregnant uterus, the patient was offered induced abortion because it was believed that the risk of life-threatening septic, spontaneous miscarriage in the second trimester was increased 20-fold if the pregnancy continued with the IUD in utero. However, this belief was derived from experiences with the Dalkon Shield. There is no evidence that there is an increased risk of septic abortion if pregnancy occurs with an IUD in place other than the shield.<sup>467,468</sup> In 2010–2011, there were no deaths in the United States among women pregnant with an IUD.<sup>469</sup>

If a patient plans to terminate a pregnancy that has occurred with an IUD in place, the IUD should be removed immediately. If there is no evidence of infection, the IUD can safely be removed in a clinic or office. If an IUD is in an infected, pregnant uterus, removal of the device should be undertaken only after antibiotic therapy has been initiated, and the patient should be monitored closely for signs of septic shock.

## Congenital Anomalies

There is no evidence that exposure of a fetus to medicated IUDs is harmful. The risk of congenital anomalies is not increased among infants born to women who become pregnant with an IUD in place.<sup>467,470</sup> A case-control study did not find an increased incidence of IUD use in pregnancies resulting in limb-reduction deformities.<sup>471</sup>

## **Preterm Labor and Birth**

The incidence of preterm labor and delivery is approximately doubled when an IUD is left in place during pregnancy.<sup>469</sup>

## **Other Complications**

Obstetrical complications at delivery (e.g., hemorrhage, stillbirth, and difficulties with placenta removal) have been reported only with the Dalkon Shield in situ.

# IUD Insertion

## Patient Selection

Most patients are good candidates for IUD use. Risk factors for STIs are the most important consideration in patient selection. Women who have multiple sexual partners, whose partners have multiple partners, who are drug or alcohol dependent, and who are not in a stable sexual relationship are at greater risk of pelvic infection at the time of IUD insertion and at greater risk of acquiring a STI after IUD insertion.<sup>280,281,282</sup> It would be appropriate for these women to use condoms for STI protection and an IUD for effective contraception. Current PID is a contraindication for IUD use. Hormonal and barrier methods are better choices for these women. Nulliparous and nulligravid women can safely use the IUD, and the levonorgestrel-releasing IUS performs as well as oral contraceptives when used by young nulliparous women.<sup>472</sup> Complications, including expulsion and perforation, are no different comparing parous and nulliparous IUD users.<sup>473</sup>

Patients with heavy menstrual periods should be cautioned regarding the increase in menstrual bleeding associated with the copper IUD. Women who are anticoagulated or have a bleeding disorder are obviously not good candidates for the copper IUD, but they might benefit from the progestin IUD.

There are other conditions that can compromise success. Women who have abnormalities of uterine anatomy (bicornuate uterus, submucous myoma, cervical stenosis) may not accommodate an IUD. The IUD is not a good choice when the uterine cavity is distorted by leiomyomas. According to conventional wisdom, the few individuals who have allergies to copper or have Wilson disease (a prevalence of about 1 in 200,000) should not use copper IUDs; however, no cases of difficulty have ever been recorded, and it is doubtful, considering the low exposure to copper, that there would be a problem. The amount of copper released into the circulation per day is less than that consumed in a normal diet.<sup>474</sup> Nevertheless, barrier methods or long-acting progestin-only methods are recommended for individuals with Wilson disease.<sup>475</sup>

Because many older women have diabetes mellitus, it is worth emphasizing that no increase in adverse events has been observed with copper IUD use in women with either insulin-dependent or noninsulin-dependent diabetes.<sup>476</sup> Indeed, the IUD can be an ideal choice for a woman with diabetes, especially if vascular disease is present.

The IUD should not be dismissed just because the patient is an adolescent. Adolescents have equivocal IUD continuation rates to older women at 1 year after insertion.<sup>477</sup> Given appropriate screening, counseling, and care, the IUD can provide

long-term effective contraception for adolescents. The continuation rate with the levonorgestrel intrauterine system in a population of adolescents in the United States was 73% at 2 years and 46% at 5 years.<sup>116,478</sup> There are no major differences in IUD efficacy and side effects comparing nulligravid women with parous women.<sup>479</sup> Nulligravid women who are past users of the IUD did not have an increased risk of tubal infertility in a case-control study, but long-term IUD users in a cohort study were reported to have reduced fertility compared with oral contraceptive users and short-term IUD users.<sup>480,481</sup> The merits of the two studies can be debated (the cohort study had several confounding problems); by far most evidence indicates that IUD use does not impair fertility.<sup>332,333,334,385,482,483</sup>

A careful speculum and bimanual examination is essential prior to IUD insertion. It is important to know the position of the uterus; undetected extreme posterior uterine position is the most common reason for perforation at the time of IUD insertion. However, perforation is rare; the incidence is estimated to be less than 1 per 3,000 insertions.<sup>484</sup> A very small or large uterus, determined by examination and sounding, can preclude insertion. For successful IUD use, the uterus should preferably not sound less than 6 cm or more than 9 cm.

Preferably, the absence of cervical or vaginal infection should be established before insertion. If this is not feasible, insertion should definitely be delayed if a mucopurulent discharge of the cervix or a significant vaginitis (including vaginal bacteriosis) is present.

## Key Points: IUD Use and Medical Conditions

- A woman with a previous ectopic pregnancy can use a copper IUD or levonorgestrel IUS.
- Women with heavy menses and dysmenorrhea, including women who have a bleeding disorder or are anticoagulated, should consider the 52 mg levonorgestrel-releasing IUS.
- Current PID is a contraindication for IUD use.
- Women with diabetes mellitus, either insulin-dependent or noninsulin-dependent, can use IUDs.
- IUD insertion is relatively easier in breast-feeding women, and the rates of expulsion and uterine perforation are not increased.

## Key Points: Patient Counseling

- Protection against unwanted pregnancy begins immediately after insertion.
- Menses can be longer and heavier with the copper IUD; tampons can be used.
- There is a slightly increased risk of pelvic infection in the first few months after insertion.
- Protection against infections transmitted through the vaginal mucosa requires the use of condoms.
- Ectopic pregnancies can still occur.
- The IUD can be spontaneously expelled; monthly palpation of the IUD strings is important to avoid unwanted pregnancies. If the strings are not felt or something hard is palpable (suggestive of the IUD frame), a clinician should be notified as soon as possible. Backup contraception should be provided until the patient can be examined.

## Timing

An IUD can be safely inserted at any time after delivery, spontaneous miscarriage or induced abortion, or during the menstrual cycle. Expulsion rates were higher when the older, large plastic IUDs were inserted sooner than 8 weeks of postpartum; however, studies indicate that the copper IUDs can be inserted between 4 and 8 weeks of postpartum without an increase in pregnancy rates, expulsion, uterine perforation, or removals for bleeding and/or pain.<sup>485,486</sup> Insertion can even occur immediately after a vaginal delivery; it is not associated with an increased risk of infection, uterine perforation, postpartum bleeding, or uterine subinvolution.<sup>489,490</sup> Postvaginal delivery insertion is not recommended if intrauterine infection is present, and a slightly higher expulsion rate is to be expected compared with insertion 4–8 weeks of postpartum. The IUD can also be inserted at cesarean section; the expulsion rate is slightly lower than that with insertion immediately after vaginal delivery.<sup>489</sup>

Insertion of an IUD in breast-feeding women is relatively easier and is associated with a lower removal rate for bleeding or pain.<sup>487</sup> Reports disagree whether perforation is more common in lactating women.<sup>487,490,491</sup>

Insertions can be more difficult if the cervix is closed between menses. The advantages of insertion during or shortly after a menstrual period include a more open cervical canal, the masking of insertion-related bleeding, and the knowledge that the patient is not pregnant. These relative advantages may be outweighed by the risk of unintended pregnancy if insertion is delayed to await menstrual bleeding. In addition,



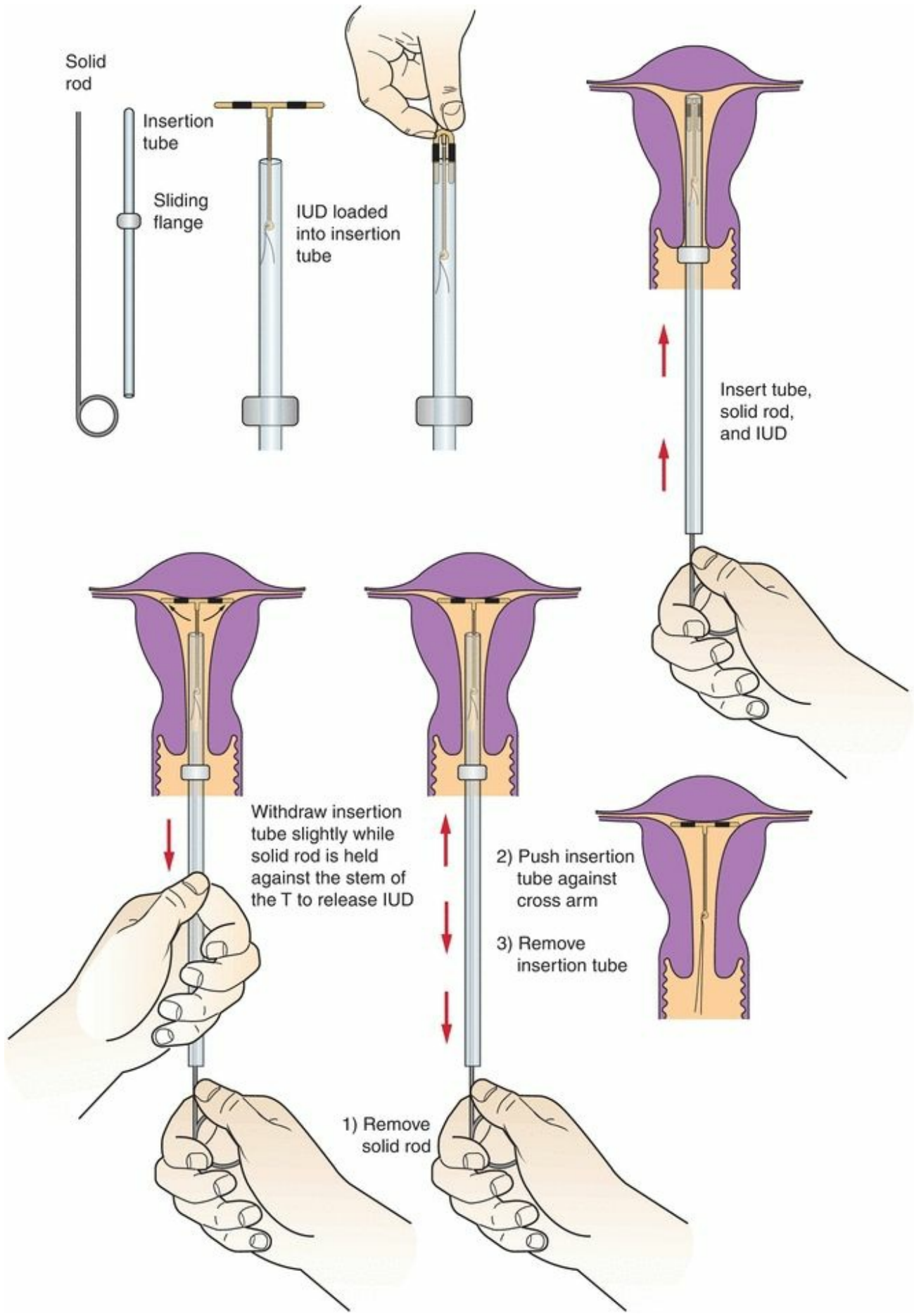
there is evidence that the expulsion rate and termination rates for pain, bleeding, and pregnancy are lower if insertions are performed after day 11 of the menstrual cycle, and the infection rate may be lower with insertions after the 17th cycle day.<sup>492</sup>

An IUD can be inserted immediately after a first-trimester abortion, but, after a second-trimester abortion, there is a higher risk of expulsion.<sup>493,494,495</sup> A decision analysis concluded that insertion of an IUD immediately after an abortion procedure would be associated with a major reduction in pregnancies compared with insertion at a follow-up visit, and, therefore, even considering expulsions, postabortion insertions are cost-effective.<sup>495</sup>

## Technique for the TCU-380A

Inserting an IUD requires only a few minutes, has few complications, and is rarely painful, but preoperative examination, medication, and the right equipment will ensure a good experience for your patient. Ensure a negative pregnancy test. After introducing a vaginal speculum, the cervix is cleaned with chlorhexidine or povidone-iodine. Many women can tolerate IUD insertion, especially at the time of menses, without a paracervical block. For some women, however, insertion is less painful with local anesthetic and with administration of a nonsteroidal anti-inflammatory agent 30 minutes to 1 hour prior to the procedure.

A paracervical block can be placed by injecting 1 mL of local anesthetic (1% chlorprocaine) into the cervical lip (anterior if the uterus is anterior in the pelvis and posterior if it lies posteriorly). Inclusion of atropine, 0.4 mg, in the anesthetic will reduce the incidence of vasovagal reactions. After 1 minute, grasp the cervical lip with the tenaculum, ratcheting it only to the first position in a slow, deliberate fashion. Use the tenaculum to move the cervix to the patient's right, revealing the left lateral vaginal fornix. Place the needle tip in the cervical mucosa at 3 o'clock, 1–2 cm lateral to the cervical os, advance it about 1.5 inches (4 cm) under the mucosa, and inject about 4 mL of anesthetic, leaving an additional 1 mL behind under the mucosa as the needle is withdrawn. Now deflect the cervix to the patient's left and inject local anesthetic at 9 o'clock in similar fashion. **Wait 2–3 minutes before proceeding.** A very common mistake is to not allow sufficient time for anesthetic action (**Figure 23.8**).



## FIGURE 23.8

If a paracervical block is not used and a tenaculum is needed, having the patient cough just as the tenaculum is applied reduces pain and the chance of a vasovagal reaction. An alternative approach for pain relief is to apply benzocaine 20% gel first at the tenaculum site and then to leave a gel-soaked cotton-tipped applicator in the cervical canal for about 1 minute before inserting the IUD.<sup>496</sup>

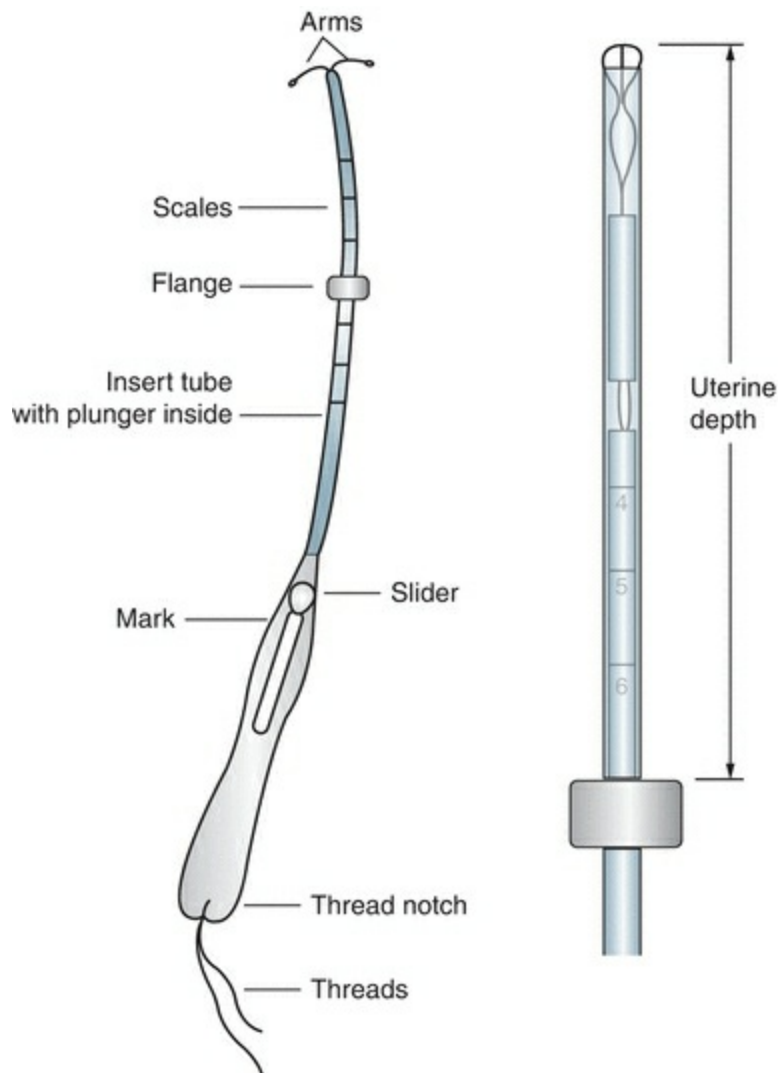
Sound and measure the depth of the uterus (the insertion tube can be used for this purpose). The IUD is loaded into its insertion tube immediately prior to insertion. The arms of the TCu-380A must be folded manually, either with sterile gloves or through the sterile wrapper, and maneuvered into the end of the insertion tube, just enough to hold them in place during insertion. The insertion tube is advanced into the uterus to the correct depth as marked on the tube by a sliding plastic flange. The flange should be twisted to be in the same plane as the horizontal arms. When the insertion tube and IUD reach the fundus, withdraw a few millimeters. Check to make sure that the transverse arm of the IUD is in the horizontal plane so that the tips of the T will rest in the cornual regions of the endometrial cavity. Placement in the vertical plane increases the risk of expulsion and pregnancy.<sup>497</sup> To release the TCu-380A, advance the solid rod until the resistance of the IUD is felt, and withdraw the insertion tube no more than 1 cm while the solid insertion rod is held against the stem of the T, releasing the transverse arms into high fundal position. Then move the insertion tube back toward the fundus until slight resistance is felt. Remove the solid rod and finally the insertion tube taking care not to pull on the strings. Trim the strings to about 4 cm from the external os, and record their length in the chart. Shorter strings can cause unpleasant bristle-like sensations.

Patients with newly inserted IUDs should attempt to feel the strings before they leave the examining room. Giving them the cut ends of the strings as a sample of what to feel is helpful. Palpation should be performed monthly by the patient to verify continuing presence of the IUD after each menstrual flow. Caution the patient that the first two menses are typically heavier. As with all office procedures, patients should be provided a 24-hour phone number for urgent questions or concerns and especially to report unusual pain, bleeding, or vaginal discharge.

A 1-month follow-up visit is recommended to identify problems amenable to counseling and treatment. Women experiencing heavier menstrual flow or irregular bleeding in the 1st month after insertion are at increased risk for removals because of bleeding and pain.<sup>498</sup> Intensified support along with treatment with a nonsteroidal anti-inflammatory agent can maintain continuation of the method.

## Technique for the 52 mg Levonorgestrel IUD

Prepare for insertion as described above for the copper IUD with a negative pregnancy test, speculum placement, paracervical block or nonsteroidal anti-inflammatory agents, and cleansing the cervix with a surgical-grade solution. Place a tenaculum if necessary and sound the uterine depth. Open the sterile package. Make sure that the IUD arms are horizontal, and push the slider as far forward (toward the patient) as possible. Move the flange so that the forward surface is at the depth of the uterus as measured by the sound. Hold the slider firmly with a thumb or finger; move the inserter into the uterus until the flange is about 1.5–2.0 cm from the cervix (this allows space for the arms to open). Holding the inserter steady, release the arms by pulling the slider back until it reaches the mark (the raised horizontal line); wait for 10 seconds for the arms to completely open. Holding the slider in its new position, advance the inserter gently until the flange touches the cervix, placing the IUD high in the fundus (**Figure 23.9**). Release the IUD by pulling the slider down, making sure that the strings release from the notch. Remove the inserter and trim the strings.



**FIGURE 23.9**

Insertion against the anterior fundus is essential for maximal efficacy and low expulsion rates. Correct placement can be assessed with ultrasonography; this is especially useful when inserting IUDs in larger cavities (after a pregnancy or when myomas are present).

## Prophylactic Antibiotics

In women at low risk for STIs, the incidence of infection is so low that there is little benefit to be expected with prophylactic antibiotics, and they are not recommended.<sup>499</sup>

# IUD Removal

Removal of an IUD can usually be accomplished by grasping the string with a ring forceps or uterine dressing forceps and exerting firm traction. If strings cannot be seen, they can often be extracted from the cervical canal by rotating two cotton-tipped applicators or a Pap smear cytobrush in the endocervical canal. If further maneuvers are required, a paracervical block may be administered. Oral administration of a nonsteroidal anti-inflammatory drug beforehand will reduce uterine cramping.

If IUD strings cannot be identified or extracted from the endocervical canal, a light plastic uterine sound should be passed into the endometrial cavity. A standard metal sound is too heavy and insensitive for this purpose. The IUD can frequently be felt with the sound and localized against the anterior or posterior wall of the uterus. The device can then be removed using a Facit polyp or alligator-type forceps directed to where the device was felt, taking care to open the forceps widely immediately on passing it through the internal cervical os so that the IUD can be caught between the jaws. If removal is not easily accomplished using this forceps, direct visualization of the IUD with sonography or hysteroscopy can facilitate removal. Sonography is less painful and more convenient and should be tried first.

Fertility returns promptly, and pregnancies after removal of an IUD occur at a normal rate, sooner than after oral contraception.<sup>332,333,334,335,385</sup> Pregnancy outcome after IUD removal is associated with a normal incidence of spontaneous miscarriage and ectopic pregnancy.<sup>385</sup>

If a patient wishes to continue the use of an IUD, a new device can be placed immediately after removal of the old one. In this case, antibiotic prophylaxis is advised.

## Embedded IUDs

If removal is not easily accomplished, direct visualization of the IUD with sonography or hysteroscopy can be helpful. Sonography is safer and less expensive.<sup>461,500</sup> Transvaginal ultrasonography provides the best image to confirm the location of the IUD, but there is little room for the removal procedure. A better approach is to fill the bladder and use an abdominal sector transducer to image the uterine cavity as the forceps are introduced. One should open the forceps widely and see if the IUD moves when the forceps close on it. If it moves, one should close the forceps tightly and extract the IUD. If unsuccessful, the forceps is reintroduced in a different plane, keeping one jaw of the open forceps firmly against first the anterior and then the posterior uterine wall. If this approach is not successful, hysteroscopy is indicated.

## Finding a Displaced IUD

When an IUD cannot be found either by direct examination or ultrasound in the office, in addition to expulsion, one has to consider perforation of the uterus into the abdominal cavity (a very rare event) or embedment into the myometrium. All IUDs are radiopaque and should be able to be localized with abdominal x-rays using 2–3 views.

If the IUD is identified perforating the myometrium or in the abdominal cavity, it should be removed using operative laparoscopy, usually under general anesthesia. If the IUD is in the uterine cavity, but cannot be grasped with a forceps under sonographic guidance, hysteroscopy is the best approach. Both routes may be helpful if an IUD is partially perforated.

Copper in the abdominal cavity can lead to adhesion formation, making laparoscopic removal difficult.<sup>501</sup> Although inert perforated devices without closed loops were previously allowed to remain in the abdominal cavity, current practice is to remove any perforated IUD, including the levonorgestrel-releasing systems. Because IUD perforations usually occur at the time of insertion, it is important to check for correct position by identifying the string within a few weeks after insertion. Uterine perforation itself is unlikely to cause more than transient pain and bleeding and can go undetected at the time of IUD insertion. If you believe perforation has occurred, prompt sonography is indicated so that the device can be removed before adhesion formation can occur.

This problem should be put into perspective. With the new generation of IUDs (copper and levonorgestrel), adhesion formation appears to be an immediate reaction that does not progress and rarely leads to serious complications.<sup>502</sup> In appropriate situations (in which the risk of surgery is considerable), clinician and patient may elect not to remove the translocated IUD in the absence of concerning symptoms.<sup>503</sup> However, a case has been reported of sigmoid perforation occurring 5 years after insertion, and the general consensus continues to favor removal of a perforated IUD immediately on diagnosis.<sup>504</sup>

# The IUD for Older Women

The growing need for reversible contraception in older women would be well served by increased utilization of the IUD. The copper and levonorgestrel IUDs are among the most effective contraceptives, better than some sterilization operations. An older woman is more likely to be mutually monogamous and less likely to develop PID, and for those women who have already had their children, concern with fertility and problems with cramping and bleeding are both lesser issues. If protection from STIs is not a concern, insertion of a copper IUD can provide very effective contraception until the menopause without the need to do anything other than check the string occasionally. On the other hand, because alterations of bleeding patterns become more common in this age group, it may be necessary to remove an IUD to avoid misinterpreting bleeding that could be due to endometrial disease. The IUD is not a good choice when the uterine cavity is distorted by leiomyomas. There are epidemiologic data indicating that the copper reduces the risks of endometrial cancer and invasive cervical cancer,<sup>416,417,418,419,420</sup> presumably because of the induced biochemical alterations that affect cellular responses.

The levonorgestrel-releasing IUS (Mirena) is especially worth considering for older women. The levonorgestrel IUS lasts up to 7 years and reduces menstrual blood loss and pelvic infection rates.<sup>299,300,301</sup> Because of the favorable impact of locally released progestin on the endometrium, the levonorgestrel IUS is very effective for the treatment of menorrhagia, as effective as the administration of oral progestins (with less side effects), and compares favorably with surgical treatment (hysterectomy or endometrial ablation).<sup>339,340,341,342,343</sup> The use of the levonorgestrel-releasing IUS also reduces bleeding in women with uterine leiomyomas, and there is some evidence that this IUD reduces the prevalence of myomas, although not the volume of existing myomas.<sup>352,353,354,355,356</sup>

The 52 mg levonorgestrel IUS effectively protects the endometrium against hyperplasia in women using tamoxifen or postmenopausal estrogen therapy.<sup>304,307,308,309,310,311,372,373,374</sup> In addition, this IUD can be used to prevent and to treat endometrial hyperplasia.<sup>375,376,378</sup> But it is worth emphasizing again that although the 52 mg levonorgestrel IUD confidently provides good protection against endometrial hyperplasia, clinicians should maintain a high degree of suspicion of unusual bleeding and aggressively assess the endometrium.



# IUD MYTHS

---

We hope the information in this chapter lays to rest specific myths associated with IUDs. For emphasis, the following sentences provide the correct responses to what we believe are common misconceptions among clinicians:

1. IUDs are not abortifacients.
2. An increased risk of infection with the modern IUD is related only to the insertion.
3. IUD use does not increase the risk of PID or infertility.
4. IUDs do not increase the risk of ectopic pregnancy and CAN be used by women with a previous ectopic.
5. IUDs CAN be used by nulliparous women.
6. IUDs CAN be inserted immediately postpartum, including after first- and second-trimester abortions.
7. IUDs CAN be inserted in HIV-positive women.
8. The modern IUD HAS NOT exposed clinicians to litigation.

# REFERENCES

1. **United Nations, Department of Economic and Social Affairs**, Trends in Contraceptive Use Worldwide, 2015.
2. **Kost K, Singh S, Vaughan B, Trussell J, Bankole A**, Estimates of contraceptive failure from the 2002 National Survey of Family Growth, *Contraception* 77:10, 2008.
3. **Darney PD, Elizabeth A, Tanner S, MacPherson S, Hellerstein S, Alvarado A**, Acceptance and perceptions of Norplant among users in San Francisco, USA, *Stud Fam Plann* 21:152, 1990.
4. **Hubacher D, Spector H, Monteith C, Chen PL, Hart C**, Long-acting reversible contraceptive acceptability and unintended pregnancy among women presenting for short-acting methods: a randomized patient preference trial, *Am J Obstet Gynecol* 216:101, 2017.
5. **Sivin I, Lähteenmäki P, Ranta S, Darney P, Klaisle C, Wan L, Mishell DR Jr, Lacarra M, Viegas OAC, Bilhareus P, Koetsawang S, Piya-Anant M, Diaz S, Pavez M, Alvarez F, Brache V, LaGuardia K, Nash H, Stern J**, Levonorgestrel concentrations during use of levonorgestrel rod (LNG ROD) implants, *Contraception* 55:81, 1997.
6. **Sivin I, Alvarez F, Mishell DR Jr, Darney P, Wan L, Brache V, Lacarra M, Klaisle C, Stern J**, Contraception with two levonorgestrel rod implants. A 5-year study in the United States and Dominican Republic, *Contraception* 58:275, 1998.
7. **Wan LS, Stiber A, Lam LY**, The levonorgestrel two-rod implant for long-acting contraception: 10 years of clinical experience, *Obstet Gynecol* 102:24, 2003.
8. **Shastri PV**, Toxicology of polymers for implant contraceptives in women, *Contraception* 65:9, 2002.
9. **Schnabel P, Merki-Feld GS, Malvy A, Duijkers I, Mommers E, van den Heuvel MW**, Bioequivalence and x-ray visibility of a radiopaque etonogestrel implant versus a non-radiopaque implant: a 3-year, randomized, double-blind study, *Clin Drug Investig* 32:413, 2012.
10. **Huber J, Wenzl R**, Pharmacokinetics of Implanon. An integrated analysis, *Contraception* 58(Suppl):85S, 1998.
11. **Egberg N, van Beek A, Gunnervik C, Hulkko S, Hirvonen E, Larsson-Cohn U, Bennink HC**, Effects on the hemostatic system and liver function in relation to Implanon® and Norplant®, *Contraception* 58:93, 1998.
12. **Affandi B**, An integrated analysis of vaginal bleeding patterns in clinical trials of Implanon®, *Contraception* 58:99S, 1998.
13. **Urbancsek J**, An integrated analysis of nonmenstrual adverse events with Implanon®, *Contraception* 58(Suppl):109S, 1998.
14. **Zheng S-R, Zheng H-M, Qian S-Z, Sang G-W, Kaper RF**, A randomized multicenter study comparing the efficacy and bleeding pattern of a single-rod (Implanon®) and a six-capsule (Norplant®) hormonal contraceptive implant, *Contraception* 60:1, 1999.
15. **Haukkamaa M**, Contraception by Norplant subdermal capsules is not reliable in epileptic patients on anticonvulsant treatment, *Contraception* 33:559, 1986.
16. **Sivin I**, International experience with Norplant and Norplant-2 contraceptives, *Stud Fam Plann* 19:81, 1988.
17. **Faculty of Family Planning and Reproductive Healthcare**, Drug interactions with hormonal contraception, *J Fam Plann Reprod Health Care* 31:139, 2005.
18. **Mäkäräinen L, van Beek A, Tuomivaara L, Asplund B, Coelingh Bennink H**, Ovarian function during the use of a single contraceptive implant: Implanon compared with Norplant, *Fertil Steril* 69:714, 1998.
19. **Brache V, Faundes A, Johansson E, Alvarez F**, Anovulation, inadequate luteal phase, and poor sperm penetration in cervical mucus during prolonged use of Norplant implants, *Contraception* 31:261, 1985.
20. **Dunson TR, Blumenthal PD, Alvarez F, Brache V, Cochon L, Dalberth B, Glover L, Remsburg R, Vu K, Katz D**, Timing of onset of contraceptive effectiveness in Norplant implant users. Part I. Changes in cervical mucus, *Fertil Steril* 69:258, 1998.
21. **Brache V, Alvarez-Sanchez F, Faundes A, Tejada AS, Cochon L**, Ovarian endocrine function through five years of continuous treatment with Norplant subdermal contraceptive implants, *Contraception* 41:169, 1990.

22. **Darney P, Patel A, Rosen K, Shapiro LS, Kaunitz AM**, Safety and efficacy of a single-rod etonogestrel implant (Implanon): results from 11 international clinical trials, *Fertil Steril* 91:1646, 2009.
23. **Morrell, KM, Cremers S, Westhoff CL, Davis AR**, Relationship between etonogestrel level and BMI in women using the contraceptive implant for more than 1 year, *Contraception* 93:263, 2016.
24. **Affandi B, Cekan S, Boonkasemanti R, Samil RS, Diczfalusy E**, The interaction between sex hormone binding globulin and levonorgestrel released from Norplant, an implantable contraceptive, *Contraception* 35:135, 1987.
25. **Alvarez F, Brache V, Tejada AS, Faundes A**, Abnormal endocrine profile among women with confirmed or presumed ovulation during long-term Norplant use, *Contraception* 33:111, 1986.
26. **Croxatto HB, Mäkäräinen L**, The pharmacodynamics and efficacy of Implanon®, *Contraception* 58:91S, 1998.
27. **Croxatto HB, Diaz S, Salvatierra AM, Morales P, Ebensperger C, Brandeis A**, Treatment with Norplant subdermal implants inhibits sperm penetration through cervical mucus in vitro, *Contraception* 36:193, 1987.
28. **Croxatto HB**, Mechanisms that explain the contraceptive action of progestin implants for women, *Contraception* 65:21, 2002.
29. **Segal SJ, Alvarez-Sanchez F, Brache V, Faundes A, Vilja P, Tuohimaa P**, Norplant implants: the mechanism of contraceptive action, *Fertil Steril* 56:273, 1991.
30. **Shaaban MM, Salem HT, Abdullah KA**, Influence of levonorgestrel contraceptive implants, Norplant, initiated early postpartum, upon lactation and infant growth, *Contraception* 32:623, 1985.
31. **Diaz S, Herreros C, Juez G, Casado ME, Salvatierra AM, Miranda P, Peralta O, Croxatto HB**, Fertility regulation in nursing women: influence of Norplant levonorgestrel implants upon lactation and infant growth, *Contraception* 32:53, 1985.
32. **Braga GC, Ferrioli E, Quintana SM, Ferriani RA, Pfrimer K, Vieira CS**, Immediate postpartum initiation of etonogestrel-releasing implant: a randomized controlled trial on breastfeeding impact, *Contraception* 92:536, 2015.
33. **Brito MB, Ferriani RA, Quintana SM, Yazlle MEH, Silva de Sá MF, Vieira CS**, Safety of the etonogestrel-releasing implant during the immediate postpartum period: a pilot study, *Contraception* 80:519, 2009.
34. **Sivin I, Stern J, Diaz S, Pavez M, Alvarez F, Brache V, Mishell DR Jr, Lacarra M, McCarthy T, Holma P, Darney P, Klaisle C, Olsson S-E, Odlind V**, Rates and outcomes of planned pregnancy after use of Norplant capsules, Norplant II rods, or levonorgestrel-releasing or copper TCu 380Ag intrauterine contraceptive devices, *Am J Obstet Gynecol* 166:1208, 1992.
35. **Diaz S, Pavez M, Cardenas H, Croxatto HB**, Recovery of fertility and outcome of planned pregnancies after the removal of Norplant subdermal implants or copper-T IUDs, *Contraception* 35:569, 1987.
36. **Croxatto HB**, Clinical profile of Implanon: a single-rod etonogestrel contraceptive implant, *Eur J Contracept Reprod Health Care* 5(Suppl 2):21, 2000.
37. **Lockhat FB, Emembolu JO, Konje JC**, The evaluation of the effectiveness of an intrauterine-administered progestogen (levonorgestrel) in the symptomatic treatment of endometriosis and in the staging of the disease, *Hum Reprod* 19:179, 2004.
38. **Bahamondes L, Petta CA, Fernandes A, Monteiro I**, Use of the levonorgestrel-releasing intrauterine system in women with endometriosis, chronic pelvic pain and dysmenorrhea, *Contraception* 75:S134, 2007.
39. **Vercellini P, Frontino G, De Giorgi O, Aimi G, Zaina B, Crosignani PG**, Comparison of a levonorgestrel-releasing intrauterine device versus expectant management after conservative surgery for symptomatic endometriosis: a pilot study, *Fertil Steril* 80:305, 2003.
40. **Crosignani PG, Luciano A, Ray A, Bergqvist A**, Subcutaneous depot medroxyprogesterone acetate versus leuprolide acetate in the treatment of endometriosis-associated pain, *Hum Reprod* 21:248, 2006.
41. **Walch K, Unfried G, Huber J, Kurz C, van Trotsenburg M, Pernicka E, Wenzl R**, Implanon versus medroxyprogesterone acetate: effects on pain scores in patients with symptomatic endometriosis—a pilot study, *Contraception* 79:29, 2009.

42. **Dunson TR, Amatya RN, Krueger SL**, Complications and risk factors associated with the removal of Norplant implants, *Obstet Gynecol* 85:543, 1995.
43. **Brache V, Faundes A, Alvarez F, Cochon L**, Non-menstrual adverse events during use of implantable contraceptives for women: data from clinical trials, *Contraception* 65:63, 2002.
44. **Darney PD, Callegari LS, Swift A, Atkinson ES, Robert AM**, Condom practices of urban teens using Norplant contraceptive implants, oral contraceptives, and condoms for contraception, *Am J Obstet Gynecol* 180:929, 1999.
45. **Lipetz C, Phillips CJ, Fleming CF**, The cost-effectiveness of a long-acting reversible contraceptive (Implanon) relative to oral contraception in a community setting, *Contraception* 79:304, 2009.
46. **Crespi S, Kerrigan M, Sood V**, Budget impact analysis of 8 hormonal contraceptive options, *Am J Manag Care* 19:e249, 2013.
47. **Trussell J, Hassan F, Lowin J, Law A, Filonenko A**, Achieving cost-neutrality with long-acting reversible contraceptive methods, *Contraception* 91:49, 2015.
48. **Berenson AB, Wiemann CM, Rickerr VI, McCombs SL**, Contraceptive outcomes among adolescents prescribed Norplant implants versus oral contraceptives after one year of use, *Am J Obstet Gynecol* 176:586, 1997.
49. **Zibners A, Cromer BA, Hayes J**, Comparison of continuation rates for hormonal contraception among adolescents, *J Pediatr Adolesc Gynecol* 12:90, 1999.
50. **Diedrich JT, Klein DA, Peipert JF**, Long-acting reversible contraception in adolescents: a systematic review and meta-analysis, *Am J Obstet Gynecol* 216:364, 2017.
51. **Affandi B, Korver T, Geurts TB, Coelingh Bennink JH**, A pilot efficacy study with a single-rod contraceptive implant (Implanon) in 200 Indonesian women treated for < or = 4 years, *Contraception* 59:167, 1999.
52. **Croxatto HB, Urbancsek J, Massai R, Coelingh Bennink H, van Beek A**, A multicentre efficacy and safety study of the single contraceptive implant Implanon. Implanon Study Group, *Hum Reprod* 14:976, 1999.
53. **Harrison-Woolrych M, Hill R**, Unintended pregnancies with the etonogestrel implant (Implanon): a case series from post-marketing experience in Australia, *Contraception* 71:306, 2005.
54. **Brache V, Blumenthal PD, Alvarez F, Dunson TR, Cochon L, Faundes A**, Timing of onset of contraceptive effectiveness in Norplant® implant users. II. Effect on the ovarian function in the first cycle of use, *Contraception* 59:245, 1999.
55. **Callahan R, Jacobson I, Halpern V, Nanda K**, Ectopic pregnancy with use of progestin-only injectables and contraceptive implants: a systematic review, *Contraception* 92:514, 2015.
56. **Sivin I, Alvarez-Sanchez F, Diaz S, Holma P, Coutinho E, McDonald O, Robertson DN, Stern J**, Three-year experience with Norplant subdermal contraception, *Fertil Steril* 39:799, 1983.
57. **Shoupe D, Mishell DR Jr, Bopp B, Fiedling M**, The significance of bleeding patterns in Norplant implant users, *Obstet Gynecol* 77:256, 1991.
58. **Sivin I, Diaz S, Holma P, Alvarez-Sanchez F, Robertson DN**, A four-year clinical study of Norplant implants, *Stud Fam Plann* 14:184, 1983.
59. **Pasquale SA, Knuppel RA, Owens AG, Bachmann GA**, Irregular bleeding, body mass index and coital frequency in Norplant contraceptive users, *Contraception* 50:109, 1994.
60. **Runic R, Schatz F, Krey L, Demopoulos R, Thung S, Wan L, Lockwood CJ**, Alterations in endometrial stromal cell tissue factor protein and messenger ribonucleic acid expression in patients experiencing abnormal uterine bleeding while using Norplant-2 contraception, *J Clin Endocrinol Metab* 82:1983, 1997.
61. **Hickey M, Simbar M, Young L, Markham R, Russell P, Fraser IS**, A longitudinal study of changes in endometrial microvascular density in Norplant® implant users, *Contraception* 59:123, 1999.
62. **Nilsson C, Holma P**, Menstrual blood loss with contraceptive subdermal levonorgestrel implants, *Fertil Steril* 35:304, 1981.
63. **Fakeye O, Balogh S**, Effect of Norplant contraceptive use on hemoglobin, packed cell volume, and menstrual bleeding patterns, *Contraception* 39:265, 1989.
64. **Fraser IS, Weisberg E, Minehan E, Johansson ED**, A detailed analysis of menstrual blood loss in women

- using Norplant® and Nestorone® progestin-only contraceptive implants or vaginal rings, *Contraception* 61:241, 2000.
65. **International Collaborative Post-Marketing Surveillance of Norplant**, Post-marketing surveillance of Norplant® contraceptive implants: I. Contraceptive efficacy and reproductive health, *Contraception* 63:167, 2001.
  66. **Abdel-Aleem H, d’Arcangues C, Vogelsong KK, Gülmezoglu AM**, Treatment of vaginal bleeding irregularities induced by progestin only contraceptives, *Cochrane Database Syst Rev* (4):CD003449, 2007. doi:10.1002/14651858.CD003449.pub3.
  67. **Alvarez-Sanchez F, Brache V, Thevenin F, Cochon L, Faundes A**, Hormonal treatment for bleeding irregularities in Norplant implant users, *Am J Obstet Gynecol* 174:919, 1996.
  68. **Shaaban MM, Elwan SI, El-Sharkawy MM, Farghaly AS**, Effect of subdermal levonorgestrel contraceptive implants, Norplant, on liver functions, *Contraception* 30:407, 1984.
  69. **Singh K, Viegas OAC, Liew D, Singh P, Ratnam SS**, Two-year follow-up of changes in clinical chemistry in Singaporean Norplant acceptors: metabolic changes, *Contraception* 39:129, 1989.
  70. **Shaaban MM, Elwan SI, El-Kabsh MY, Farghaly SA, Thabet N**, Effect of levonorgestrel contraceptive implants, Norplant, on bleeding and coagulation, *Contraception* 30:421, 1984.
  71. **Singh K, Viegas OAC, Koh SCL, Ratnam SS**, Effect of long-term use of Norplant implants on haemostatic function, *Contraception* 45:203, 1992.
  72. **Viegas OAC, Koh SLC, Ratnam SS**, The effects of reformulated 2-rod Norplant implant on haemostasis after three years, *Contraception* 54:219, 1996.
  73. **Croxatto HB, Diaz S, Robertson D, Pavez M**, Clinical chemistries in women treated with levonorgestrel implant (Norplant) or a TCU 200 IUD, *Contraception* 27:281, 1983.
  74. **Abdulla K, Elwan SI, Salem HS, Shaaban MM**, Effect of early postpartum use of the contraceptive implants, Norplant, on the serum levels of immunoglobulin of the mothers and their breastfed infants, *Contraception* 32:261, 1985.
  75. **Bayad M, Ibrahim I, Fayad M, Hassanein AA, Hafez ES, Abdalla MI**, Serum cortisol in women users of subdermal levonorgestrel implants, *Contracept Deliv Syst* 4:133, 1983.
  76. **Roy S, Mishell DR Jr, Robertson D, Krauss RM, Lacarra M, Duda MJ**, Long-term reversible contraception with levonorgestrel-releasing Silastic rods, *Am J Obstet Gynecol* 148:1006, 1984.
  77. **Otubu JAM, Towobola OA, Aisien AO, Ogunkeye OO**, Effects of Norplant contraceptive subdermal implants on serum lipids and lipoproteins, *Contraception* 47:149, 1993.
  78. **Konje JC, Otolorin EO, Ladipo OA**, Changes in carbohydrate metabolism during 30 months on Norplant, *Contraception* 44:163, 1991.
  79. **Koopersmith TB, Lobo RA**, Insulin sensitivity is unaltered by the use of the Norplant subdermal implant contraceptive, *Contraception* 51:197, 1995.
  80. **Harper MA, Meis PJ, Steele L**, A prospective study of insulin sensitivity and glucose metabolism in women using a continuous subdermal levonorgestrel implant system, *J Soc Gynecol Investig* 4:86, 1997.
  81. **Meirik O, Farley TMM, Sivin I; International Collaborative Post-Marketing Surveillance of Norplant**, Safety and efficacy of levonorgestrel implant, intrauterine device, and sterilization, *Am J Obstet Gynecol* 97:539, 2001.
  82. **International Collaborative Post-Marketing Surveillance of Norplant**, Post-marketing surveillance of Norplant® contraceptive implants: II. Non-reproductive health, *Contraception* 63:187, 2001.
  83. **Suherman SK, Affandi B, Korver T**, The effects of Implanon on lipid metabolism in comparison with Norplant, *Contraception* 60:281, 1999.
  84. **Oderich CL, Wender MC, Lubianca JN, Santos LM, de Mello GC**, Impact of etonogestrel-releasing implant and copper intrauterine device on carbohydrate metabolism: a comparative study, *Contraception* 85:173, 2012.
  85. **Villas-Boas J, Vilodre LC, Malerba H, Salcedo MP, Jimenez MF, El Beitune P**, Metabolic safety of the etonogestrel contraceptive implant in healthy women over a 3-year period, *Eur J Obstet Gynecol Reprod Biol* 202:51, 2016.

86. **Bender NM, Segall-Gutierrez P, Lopez Najera SO, Stanczyk FZ, Montoro M, Mishell DR**, Effects of progestin-only long-acting contraception on metabolic markers in obese women, *Contraception* 88:418, 2013.
87. **Biswas A, Viegas OA, Bennink HJ, Korver T, Ratnam SS**, Effect of Implanon use on selected parameters of thyroid and adrenal function, *Contraception* 62:247, 2000.
88. **Cromer BA, Blair JM, Mahan JD, Zibners L, Naumovski Z**, A prospective comparison of bone density in adolescent girls receiving depot medroxyprogesterone acetate (Depo-Provera), levonorgestrel (Norplant), or oral contraceptives, *J Pediatr* 129:671, 1996.
89. **Beerthuizen R, van Beek A, Massai R, Mäkäräinen L, Hout J, Bennink HJ**, Bone mineral density during long-term use of the progestagen contraceptive implant Implanon compared to a non-hormonal method of contraception, *Hum Reprod* 15:118, 2000.
90. **Naessen T, Olsson SE, Gudmundson J**, Differential effects on bone density of progestogen-only methods for contraception in premenopausal women, *Contraception* 52:35, 1995.
91. **Di X, Li Y, Zhang C, Jiang J, Gu S**, Effects of levonorgestrel-releasing subdermal contraceptive implants on bone density and bone metabolism, *Contraception* 60:161, 1999.
92. **Petitti DB, Piaggio G, Mehta S, Cravioto MC, Meirik O; WHO Study of Hormonal Contraception and Bone Health**, Steroid hormone contraception and bone mineral density: a cross-sectional study in an international population, *Obstet Gynecol* 95:736, 2000.
93. **Westhoff C, Truman C, Kalmuss D, Cushman L, Rulin M, Heartwell S, Davidson A**, Depressive symptoms and Norplant® contraceptive implants, *Contraception* 57:241, 1998.
94. **Wysocki DK, Green L**, Serious adverse events in Norplant users reported to the Food and Drug Administration's MedWatch Spontaneous Reporting System, *Obstet Gynecol* 85:538, 1995.
95. **Fraser IS, Tiitinen A, Affandi B, Brache V, Croxatto HB, Diaz S, Ginsburg J, Gu S, Holma P, Johansson E, Meirik O, Mishell DR Jr, Nash HA, von Schoultz B, Sivin I**, Norplant® consensus statement and background review, *Contraception* 57:1, 1998.
96. **Lopez LM, Ramesh S, Chen M, Edelman A, Otterness C, Trussell J, Helmerhorst FM**, Progestin-only contraceptives: effects on weight, *Cochrane Database Syst Rev* (8):CD008815, 2016. doi:10.1002/14651858.CD008815.pub4.
97. **Faundes A, Brache V, Tejada AS, Cochon L, Alvarez-Sanchez F**, Ovulatory dysfunction during continuous administration of low-dose levonorgestrel by subdermal implants, *Fertil Steril* 56:27, 1991.
98. **Darney PD, Taylor RN, Klaisle C, Bottles K, Zaloudek C**, Serum concentrations of estradiol, progesterone, and levonorgestrel are not determinants of endometrial histology or abnormal bleeding in long-term Norplant implant users, *Contraception* 53:97, 1996.
99. **Strom BL, Berlin JA, Weber AL, Norman SA, Bernstein L, Burkman RT, Daling JR, Deapen D, Folger SG, Malone KE, Marchbanks PA, Simon MS, Ursin G, Weiss LK, Spirtas R**, Absence of an effect of injectable and implantable progestin-only contraceptives on subsequent risk of breast cancer, *Contraception* 69:353, 2004.
100. **Phemister DA, Laurent S, Harrison FNH Jr**, Use of Norplant contraceptive implants in the immediate postpartum period: safety and tolerance, *Am J Obstet Gynecol* 172:175, 1995.
101. **Darney PD, Klaisle CM, Tanner S, Alvarado AM**, Sustained-release contraceptives, *Curr Probl Obstet Gynecol Fertil* 13:95, 1990.
102. **Zimmerman M, Haffey J, Crane E, Szumowski D, Alvarez F, Bhiromrut P, Brache V, Lubis F, Salah M, Shaaban MM, Shawly B, Sidiip S**, Assessing the acceptability of Norplant implants in four countries: findings from focus group research, *Stud Fam Plann* 21:92, 1990.
103. **Mascarenhas L**, Insertion and removal of Implanon: practical considerations, *Eur J Contracept Reprod Health Care* 5(Suppl 2):29, 2000.
104. **Lantz A, Noshier JL, Pasquale S, Siegel RL**, Ultrasound characteristics of subdermally implanted Implanon contraceptive rods, *Contraception* 56:323, 1997.
105. **Zieman M, Klaisle C, Walker D, Bahisteri E, Darney P**, Fingers versus instruments for removing levonorgestrel contraceptive implants (Norplant), *J Gynecol Tech* 3:213, 1997.
106. **Bromham DR, Davey A, Gaffikin L, Ajello CA**, Materials, methods and results of the Norplant training

program, *Br J Fam Plann* 10:256, 1995.

107. **Creinin MD, Kaunitz AM, Darney PD, Schwartz L, Hampton T, Gordon K, Rekers H**, The US etonogestrel implant mandatory clinical training and active monitoring programs: 6-year experience, *Contraception* 95:205, 2017.
108. **Levine JP, Sinofsky FE, Christ MF**, Assessment of Implanon insertion and removal, *Contraception* 78:409, 2008.
109. **Nelson AL**, Neutralizing pH of lidocaine reduces pain during Norplant system insertion procedures, *Contraception* 51:299, 1995.
110. **Ismail H, Mansour D, Singh M**, Migration of Implanon, *J Fam Plann Reprod Health Care* 32:157, 2006.
111. **Klavon SL, Grubb G**, Insertion site complications during the first year of Norplant use, *Contraception* 41:27, 1990.
112. **Blain S, Oloto E, Meyrick I, Bromham D**, Skin reactions following Norplant® insertion and removal—possible causative factors, *Br J Fam Plann* 21:130, 1996.
113. **Darney PD, Klaisle CM, Walker DM**, The pop-out method of Norplant removal, *Adv Contracept* 8:188, 1992.
114. **Glauser SJ, Scharling ES, Stovall TG, Zagoria RJ**, Ultrasonography: usefulness in localization of the Norplant contraceptive implant system, *J Ultrasound Med* 14:411, 1995.
115. **Diedrich JT, Zhao Q, Madden T, Secura GM, Peipert JF**, Three-year continuation of reversible contraception, *Am J Obstet Gynecol* 215:662, 2015.
116. **Abraham M, Zhao Q, Peipert JF**, Young age, nulliparity, and continuation of long-acting reversible contraceptive methods, *Obstet Gynecol* 126:823, 2015.
117. **Smith A, Reuter S**, An assessment of the use of Implanon in three community services, *J Fam Plann Reprod Health Care* 28:193, 2002.
118. **Gu S, Sivin I, Du M, Zhang L, Ying-Lin L, Meng F, Wu S, Wang P, Gao Y, He X, Qi L, Chen C, Liu Y, Wang D**, Effectiveness of Norplant implants through seven years: a large-scale study in China, *Contraception* 52:99, 1995.
119. **Reuter S, Smith A**, Implanon: user views in the first year across three family planning services in the Trent Region, UK, *Eur J Contracept Reprod Health Care* 8:27, 2003.
120. **Dugoff L, Jones OW III, Allen-Davis J, Hurst BS, Schlaff WD**, Assessing the acceptability of Norplant contraceptive in four patient populations, *Contraception* 52:45, 1995.
121. **Cromer BA, Smith RD, Blair JM, Dwyer J, Brown RT**, A prospective study of adolescents who choose among levonorgestrel implant (Norplant), medroxyprogesterone acetate (Depo-Provera), or the combined oral contraceptive pill as contraception, *Pediatrics* 94:687, 1994.
122. **Cullins VE, Remsburg RE, Blumenthal PD, Huggins GR**, Comparison of adolescent and adult experience with Norplant levonorgestrel contraceptive implants, *Obstet Gynecol* 83:1026, 1994.
123. **Polanczky M, Slap G, Forke C, Rappaport A, Sondheimer S**, The use of levonorgestrel implants (Norplant) for contraception in adolescent mothers, *N Engl J Med* 331:1201, 1994.
124. **Berenson AB, Wiemann CM**, Use of levonorgestrel implants versus oral contraceptives in adolescence: a case-control study, *Am J Obstet Gynecol* 172:1128, 1995.
125. **Coutinho EM**, One year contraception with a single subdermal implant containing norgestrel acetate (Uniplant), *Contraception* 47:94, 1993.
126. **Haukkaa M, Laurikka-Routti M, Heikinheimo O, Moo-Young A**, Contraception with subdermal implants releasing the progestin ST-1435: a dose-finding study, *Contraception* 45:49, 1992.
127. **Diaz S, Schiappacasse V, Pavez M, Zepeda A, Moo-Young AJ, Brandeis A, Lahteenmaki P, Croxatto HB**, Clinical trial with Nestorone subdermal contraceptive implants, *Contraception* 51:33, 1995.
128. **Rosenfield A, Maine D, Rochat R, Shelton J, Hatcher R**, The Food and Drug Administration and medroxyprogesterone acetate: what are the issues? *JAMA* 249:2922, 1983.
129. **WHO**, A multicentered phase III comparative clinical trial of depot-medroxyprogesterone acetate given three-monthly at doses of 100 mg or 150 mg: I. Contraceptive efficacy and side effects, *Contraception* 34:223, 1986.
130. **WHO**, Multinational comparative clinical evaluation of two long-acting injectable contraceptive steroids:

- norethisterone enanthate and medroxyprogesterone acetate. Final report, *Contraception* 28:1, 1983.
131. **Jain J, Dutton C, Nicosia A, Wajszczuk C, Bode FR, Mishell DR Jr**, Pharmacokinetics, ovulation suppression and return to ovulation following a lower dose subcutaneous formulation of Depo-Provera, *Contraception* 70:11, 2004.
  132. **Jain J, Jakimiuk AJ, Bode FR, Ross D, Kaunitz AM**, Contraceptive efficacy and safety of DMPA-SC, *Contraception* 70:269, 2004.
  133. **Kaunitz AM, Darney PD, Ross D, Wolter KD, Speroff L**, Subcutaneous DMPA vs. intramuscular DMPA: a 2-year randomized study of contraceptive efficacy and bone mineral density, *Contraception* 80:7, 2009.
  134. **Mishell DR Jr**, Effect of 6 methyl-17-hydroxyprogesterone on urinary excretion of luteinizing hormone, *Am J Obstet Gynecol* 99:86, 1967.
  135. **Fraser IS, Weisberg EA**, A comprehensive review of injectable contraception with special emphasis on depot medroxyprogesterone acetate, *Med J Aust* 1(Suppl):3, 1981.
  136. **Pardthaisong T, Gray RH**, In utero exposure to steroid contraceptives and outcome of pregnancy, *Am J Epidemiol* 134:795, 1991.
  137. **Gray RH, Pardthaisong T**, In utero exposure to steroid contraceptives and survival during infancy, *Am J Epidemiol* 134:804, 1991.
  138. **Siriwongse T, Snidvonga W, Tantayaporn P, Leepipalboon S**, Effect of depot-medroxyprogesterone acetate on serum progesterone levels, when administered on various cycle days, *Contraception* 26:487, 1982.
  139. **Petta C, Faúndes A, Dunson TR, Ramos M, DeLucio M, Faúndes D, Bahamondes L**, Timing of onset of contraceptive effectiveness in Depo-Provera users. I. Changes in cervical mucus, *Fertil Steril* 69:252, 1998.
  140. **Petta CA, Faúndes A, Dunson TR, Ramos M, DeLucio M, Faúndes D, Bahamondes L**, Timing of onset of contraceptive effectiveness in Depo-Provera users. II. Effects on ovarian function, *Fertil Steril* 70:817, 1998.
  141. **Nelson AL, Katz T**, Initiation and continuation rates seen in 2-year experience with Same Day injections of DMPA, *Contraception* 75:84, 2007.
  142. **Rickert VI, Tiezzi L, Lipshutz J, León J, Vaughan RD, Westhoff C**, Depo Now: preventing unintended pregnancies among adolescents and young adults, *J Adolesc Health* 40:22, 2007.
  143. **Steiner MJ, Kwok C, Stanback J, Byamugisha JK, Chipato T, Magwali T, Mmiro F, Rugpao S, Sriplienchan S, Morrison C**, Injectable contraception: what should the longest interval be for reinjections? *Contraception* 77:410, 2008.
  144. **Harlap S, Kost K, Forrest JD**, Preventing Pregnancy, Protecting Health: A New Look at Birth Control Choices in the United States, The Alan Guttmacher Institute, New York, 1991.
  145. **Darney P, Jain J, Jakimiuk AJ**, Zero pregnancies with new low dose depot medroxyprogesterone acetate subcutaneous injection for contraception (abstract), *Fertil Steril* 82:S105, 2004.
  146. **O'Dell CM, Forke CM, Polanczky MM, Sondheimer SJ, Slap GB**, Depot medroxyprogesterone acetate or oral contraception in postpartum adolescents, *Obstet Gynecol* 91:609, 1998.
  147. **Polanczky M, Guarnaccia M, Alon J, Wiley J**, Early experience with the contraceptive use of depot-medroxyprogesterone acetate in an inner-city population, *Fam Plann Perspect* 28:174, 1996.
  148. **Tepper NK, Whiteman MK, Marchbanks PA, James AH, Curtis KM**, Progestin-only contraception and thromboembolism: a systematic review, *Contraception* 94:678, 2016.
  149. **World Health Organization Collaborative Study of Cardiovascular Disease and Steroid Hormone Contraception**, Cardiovascular disease and use of oral and injectable progestogen-only contraceptives and combined injectable contraceptives. Results of an international, multicenter, case-control study, *Contraception* 57:315, 1998.
  150. **Poulter NR, Chang CL, Farley TMM, Meirik O**, Risk of cardiovascular diseases associated with oral progestagen preparations with therapeutic indications, *Lancet* 354:1610, 1999.
  151. **Vasilakis C, Jick H, del Mar Melero-Montes M**, Risk of idiopathic venous thromboembolism in users of progestagens alone, *Lancet* 354:1610, 1999.
  152. **DeCearl K, Gruber C, Hayes R, Serjeant GR**, Medroxyprogesterone acetate and homozygous sickle-cell disease, *Lancet* ii:229, 1982.
  153. **de Abood M, de Castillo Z, Guerrero F, Espino M, Austin KL**, Effect of Depo-Provera® or



- Microgynon® on the painful crises of sickle-cell anemia patients, *Contraception* 56:313, 1997.
154. **Jimenez J, Ochoa M, Soler MP, Portales P**, Long-term follow-up of children breast-fed by mothers receiving depot-medroxyprogesterone acetate, *Contraception* 30:523, 1984.
  155. **Zacharias S, Aguilena J, Assanzo JR, Zanatu J**, Effects of hormonal and non-hormonal contraceptives on lactation and incidence of pregnancy, *Contraception* 33:203, 1986.
  156. **Pardthaisong T, Yenchit C, Gray R**, The long-term growth and development of children exposed to Depo-Provera during pregnancy or lactation, *Contraception* 45:313, 1992.
  157. **Virutamasen P, Leepipatpaiboon S, Kriengsinyot R, Vichaidith P, Muia PN, Sekadde-Kigundu CB, Mati JKG, Forest MG, Dikkeschei LD, Wolthers BG, d’Arcangues C**, Pharmacodynamic effects of depot-medroxyprogesterone acetate (DMPA) administered to lactating women on their male infants, *Contraception* 54:153, 1996.
  158. **Halderman LD, Nelson AL**, Impact of early postpartum administration of progestin-only hormonal contraceptives compared with nonhormonal contraceptives on short-term breast-feeding patterns, *Am J Obstet Gynecol* 186: 1250, 2002.
  159. **Xiang AH, Kawakubo M, Kjos SL, Buchanan TA**, Long-acting injectable progestin contraception and risk of type 2 diabetes in Latino women with prior gestational diabetes mellitus, *Diabetes Care* 29:613, 2006.
  160. **Mattson RH, Cramer JA, Caldwell BV, Siconolfi BC**, Treatment of seizures with medroxyprogesterone acetate: preliminary report, *Neurology* 34:1255, 1984.
  161. **Sönmezer M, Atabekoglu C, Cengiz B, Dökmeci F, Cengiz SD**, Depot-medroxyprogesterone acetate in anticoagulated patients with previous hemorrhagic corpus luteum, *Eur J Contracept Reprod Health Care* 10:9, 2005.
  162. **WHO Collaborative Study of Neoplasia and Steroid Contraceptives**, Depot-medroxyprogesterone acetate (DMPA) and risk of endometrial cancer, *Int J Cancer* 49:186, 1991.
  163. **Wilailak S, Vipupinyo C, Suraseranivong V, Chotivanich K, Kietpeerakool C, et al**, Depot medroxyprogesterone acetate and epithelial ovarian cancer: a multicenter case-control study, *Br J Obstet Gynaecol* 119:672, 2012.
  164. **WHO Collaborative Study of Neoplasia and Steroid Contraceptives**, Depot-medroxyprogesterone acetate (DMPA) and risk of epithelial ovarian cancer, *Int J Cancer* 49:191, 1991.
  165. **Lumbiganon P, Rugpao S, Phandhu-fung S, Laopaiboon M, Vudhikamraksa N, Werawatkul Y**, Protective effect of depot-medroxyprogesterone acetate on surgically treated uterine leiomyomas: a multicentre case-control study, *Br J Obstet Gynaecol* 103:909, 1996.
  166. **Gray RH**, Reduced risk of pelvic inflammatory disease with injectable contraceptives, *Lancet* i:1046, 1985.
  167. **Gardner JM, Mishell DR Jr**, Analysis of bleeding patterns and resumption of fertility following discontinuation of a long-acting injectable contraceptive, *Fertil Steril* 21:286, 1970.
  168. **Arias RD, Jain JK, Brucker C, Ross D, Ray A**, Changes in bleeding patterns with depot medroxyprogesterone acetate subcutaneous injection 104 mg, *Contraception* 74:234, 2006.
  169. **Harel Z, Biro FM, Kollar LM**, Depo-Provera in adolescents: effects of early second injection or prior oral contraception, *J Adolesc Health* 16:379, 1995.
  170. **Goldberg AB, Cardenas LH, Hubbard AE, Darney PD**, Post-abortion depot medroxyprogesterone acetate continuation rates: a randomized trial of cyclic estradiol, *Contraception* 66:215, 2002.
  171. **Thurman AR, Livengood CH, Soper DE**, Chronic endometritis in DMPA users and Chlamydia trachomatis endometritis, *Contraception* 76:49, 2007.
  172. **Westhoff C, Wieland D, Tiezzi L**, Depression in users of depot-medroxyprogesterone acetate, *Contraception* 51:351, 1995.
  173. **Westhoff C, Truman C, Kalmuss D, Cushman L, Davidson A, Rulin M, Heartwell S**, Depressive symptoms and Depo-Provera, *Contraception* 57:237, 1998.
  174. **Gupta N, O’Brien R, Jacobsen LJ, Davis A, Zuckerman A, Supran S, Kulig J**, Mood changes in adolescents using depot-medroxyprogesterone acetate for contraception: a prospective study, *J Pediatr Adolesc Gynecol* 14:71, 2001.
  175. **Singata-Madliki M, Hofmeyr GJ, Lawrie TA**, The effect of depot medroxyprogesterone acetate on

postnatal depression: a randomized controlled trial, *J Fam Plann Reprod Health Care* 42:171, 2016.

176. **Moore LL, Valuck R, McDougall C, Fink W**, A comparative study of one-year weight gain among users of medroxyprogesterone acetate, levonorgestrel implants, and oral contraceptives, *Contraception* 52:215, 1995.
177. **Mainwaring R, Hales HA, Stevenson K, Hatasaka HH, Poulson AM, Jones KP, Peterson CM**, Metabolic parameters, bleeding, and weight changes in U.S. women using progestin only contraceptives, *Contraception* 51:149, 1995.
178. **Taneepanichskul S, Reinprayoon D, Khaosaad P**, Comparative study of weight change between long-term DMPA and IUD acceptors, *Contraception* 58:149, 1998.
179. **Bahamondes L, Del Castillo S, Tabares G, Arce XE, Perrotti M, Petta C**, Comparison of weight increase in users of depot medroxyprogesterone acetate and copper IUD up to 5 years, *Contraception* 64:223, 2001.
180. **Berenson AB, Rahman M**, Changes in weight, total fat, percent body fat, and central-to-peripheral fat ratio associated with injectable and oral contraceptive use, *Am J Obstet Gynecol* 200:329.e1, 2009.
181. **Westhoff C, Jain JK, Milsom I, Ray A**, Changes in weight with depot medroxyprogesterone acetate subcutaneous injection 104mg/0.65 mL, *Contraception* 75:261, 2007.
182. **Bonny AE, Ziegler J, Harvey R, Debanne SM, Secic M, Cromer BA**, Weight gain in obese and nonobese adolescent girls initiating depot medroxyprogesterone, oral contraceptive pills, or no hormonal contraceptive method, *Arch Pediatr Adolesc Med* 160:40, 2006.
183. **Beksinska ME, Smit JA, Keleinschmidt I, Milford C, Farley T**, Prospective study of weight change in new adolescent users of DMPA, NET-EN, COCs, nonusers and discontinuers of hormonal contraception, *Contraception* 81:30, 2010.
184. **Espey E, Steinhart J, Ogburn T, Qualls C**, Depo-provera associated with weight gain in Navajo women, *Contraception* 62:55, 2000.
185. **Kim C, Seidel KW, Begier EA, Kwok YS**, Diabetes and depot medroxyprogesterone contraception in Navajo women, *Arch Intern Med* 161:1766, 2001.
186. **Le Y-CL, Rahman M, Berenson AB**, Early weight gain predicting later weight gain among depot medroxyprogesterone acetate users, *Obstet Gynecol* 114:279, 2009.
187. **Jacobson DL, Peralta L, Farmer M, Graham NM, Gaydos C, Zenilman J**, Relationship of hormonal contraception and cervical ectopy as measured by computerized planimetry to chlamydial infection in adolescents, *Sex Transm Dis* 27:313, 2000.
188. **Baeten JM, Nyange PM, Richardson BA, Lavreys L, Chohan B, Martin HL, Mandaliya K, Nidinya-Achola JO, Bwayo JJ, Kreiss JK**, Hormonal contraception and risk of sexually transmitted disease acquisition: results from a prospective study, *Am J Obstet Gynecol* 185:380, 2001.
189. **Morrison CS, Bright P, Wong EL, Kwok C, Yacobson I, Gaydos CA, Tucker HT, Blumenthal PD**, Hormonal contraceptive use, cervical ectopy, and the acquisition of cervical infections, *Sex Transm Dis* 31:561, 2004.
190. **Pettifor A, Delany S, Kleinschmidt I, Miller WC, Atashili J, Rees H**, Use of injectable progestin contraception and risk of STI among South African women, *Contraception* 80:555, 2009.
191. **Kleinschmidt I, Rees H, Delany S, Smith D, Dinat N, Nkala B, McIntyre JA**, Injectable progestin contraceptive use and risk of HIV infection in a South African family planning cohort, *Contraception* 75:461, 2007.
192. **Myer L, Denny L, Wright TC, Kuhn L**, Prospective study of hormonal contraception and women's risk of HIV infection in South Africa, *Int J Epidemiol* 36:166, 2007.
193. **Brooks G**, Anaphylactoid shock with medroxyprogesterone acetate: a case report, *J La State Med Soc* 126:397, 1974.
194. **Rajapaksa DS**, Anaphylaxis to Depo-Provera?, *Ceylon Med J* 38:158, 1993.
195. **Selo-Ojeme DO, Tillisi A, Welch CC**, Anaphylaxis from medroxyprogesterone acetate, *Obstet Gynecol* 103:1045, 2004.
196. **Lestishock L, Pariseau C, Rooholamini S, Ammerman S**, Anaphylaxis from depot medroxyprogesterone acetate in an adolescent girl, *Obstet Gynecol* 118:443, 2011.

197. **WHO Collaborative Study of Neoplasia and Steroid Contraceptives**, Breast cancer and depot-medroxyprogesterone acetate: a multinational study, *Lancet* 338:833, 1991.
198. **Lee NC, Rosero-Bixby L, Oberle MW, Grimaldo C, Whatley AS, Rovira EZ**, A case-control study of breast cancer and hormonal contraception in Costa Rica, *J Natl Cancer Inst* 79:1247, 1987.
199. **Paul C, Skegg DCG, Spears GFS**, Depot medroxyprogesterone (Depo-Provera) and risk of breast cancer, *Br Med J* 299:7591, 1989.
200. **Skegg DCG, Noonan EA, Paul C, Spears GFS, Meirik O, Thomas DB**, Depot medroxyprogesterone acetate and breast cancer: a pooled analysis of the World Health Organization and the New Zealand studies, *JAMA* 273:799, 1995.
201. **Shapiro S, Rosenberg L, Hoffman M, Truter H, Cooper D, Rao S, Dent D, Gudgeon A, van Zyl J, Katzenellenbogen J, Bailie R**, Risk of breast cancer in relation to the use of injectable progestogen contraceptives and combined estrogen/progestogen contraceptives, *Am J Epidemiol* 151:396, 2000.
202. **The New Zealand Contraception and Health Study Group**, History of long-term use of depot-medroxyprogesterone acetate in patients with cervical dysplasia; case-control analysis nested in a cohort study, *Contraception* 50:443, 1994.
203. **Thomas DB, Ray RM; WHO Collaborative Study of Neoplasia and Steroid Contraceptives**, Depot-medroxyprogesterone acetate (DMPA) and risk of invasive adenocarcinomas and adenosquamous carcinomas of the uterine cervix, *Contraception* 52:307, 1995.
204. **WHO Collaborative Study of Neoplasia and Steroid Contraception**, Depot-medroxyprogesterone acetate (DMPA) and risk of invasive squamous cell cervical cancer, *Contraception* 45:299, 1992.
205. **Thomas DB, Ye Z, Ray RM; WHO Collaborative Study of Neoplasia and Steroid Contraception**, Cervical carcinoma in situ and use of depot-medroxyprogesterone acetate (DMPA), *Contraception* 51:25, 1995.
206. **Valente PT, Schantz HD, Trabal JF**, Cytologic changes in cervical smears associated with prolonged use of depot-medroxyprogesterone acetate, *Cancer* 84:328, 1998.
207. **WHO**, Depo-medroxyprogesterone acetate (DMPA) and cancer; memorandum from a WHO meeting, *Bull World Health Organ* 64:375, 1986.
208. **Garza-Fores J, De la Cruz DL, Valles de Bourges V, Sanchez-Nuncio R, Martinez M, Fuziwara JL, Perez-Palacios G**, Long-term effects of depot-medroxyprogesterone acetate on lipoprotein metabolism, *Contraception* 44:61, 1991.
209. **Enk L, Landgren BM, Lindberg U-B, Silverstolpe G, Crona N**, A prospective, one-year study on the effects of two long acting injectable contraceptives (depot-medroxyprogesterone acetate and norethisterone enanthate) on serum and lipoprotein lipids, *Horm Metab Res* 24:85, 1992.
210. **Berenson AB, Rahman M, Wilkinson G**, Effect of injectable and oral contraceptives on serum lipids, *Obstet Gynecol* 114:786, 2009.
211. **WHO**, A multicentre comparative study of serum lipids and apolipoproteins in long-term users of DMPA and a control group of IUD users, *Contraception* 47:177, 1993.
212. **Fahmy K, Khairy M, Allam G, Gobran F, Allush M**, Effect of depo-medroxyprogesterone acetate on coagulation factors and serum lipids in Egyptian women, *Contraception* 44:431, 1991.
213. **Fahmy K, Abdel-Razik M, Shaaraway M, Al-Kholy G, Saad S, Wagdi A, Al-Azzony M**, Effect of long-acting progestagen-only injectable contraceptives on carbohydrate metabolism and its hormonal profile, *Contraception* 44:419, 1991.
214. **Cromer VA, Lazebnik R, Rome E, Stager M, Bonny AE, Ziegler J, Debanne SM**, Double-blinded randomized controlled trial of estrogen supplementation in adolescent girls who receive depot medroxyprogesterone acetate for contraception, *Am J Obstet Gynecol* 192:42, 2005.
215. **Cundy T, Evans M, Roberts H, Wattie D, Ames R, Reid IR**, Bone density in women receiving depot medroxyprogesterone acetate for contraception, *Br Med J* 303:13, 1991.
216. **Cundy T, Cornish J, Roberts H, Elder H, Reid IR**, Spinal bone density in women using depot medroxyprogesterone contraception, *Obstet Gynecol* 92:569, 1998.
217. **Berenson AB, Breitkopf CR, Grady JJ, Rickert VI, Thomas A**, Effects of hormonal contraception on bone mineral density after 24 months of use, *Obstet Gynecol* 103:899, 2004.

218. **Clark MK, Sowers MR, Nichols S, Levy B**, Bone mineral density changes over two years in first-time users of depot medroxyprogesterone acetate, *Fertil Steril* 82:1580, 2004.
219. **Scholes D, LaCroix AZ, Ichikawa LE, Barlow WE, Ott SM**, Injectable hormone contraception and bone density: results from a prospective study, *Epidemiology* 13:581, 2002.
220. **Cundy T, Farquhar CM, Cornish J, Reid IR**, Short-term effects of high dose oral medroxyprogesterone acetate on bone density in premenopausal women, *J Clin Endocrinol Metab* 81:1014, 1996.
221. **Paiva LC, Pinto-Neto AM, Faúndes A**, Bone density among long-term users of medroxyprogesterone acetate as a contraceptive, *Contraception* 58:351, 1998.
222. **Scholes D, Lacroix AZ, Ott SM, Ichikawa LE, Barlow WE**, Bone mineral density in women using depot medroxyprogesterone acetate for contraception, *Obstet Gynecol* 93:233, 1999.
223. **Rahman M, Berenson AB**, Predictors of higher bone mineral density loss and use of depot medroxyprogesterone acetate, *Obstet Gynecol* 115:35, 2010.
224. **Cundy T, Ames R, Horne A, Clearwater J, Roberts H, Gamble G, Reid IR**, A randomized controlled trial of estrogen replacement therapy in long-term users of depot medroxyprogesterone acetate, *J Clin Endocrinol Metab* 88:78, 2003.
225. **Theitz G, Buch B, Rizzoli R, Slosman D, Clavien H, Sizonko PC, Bonjour JPH**, Longitudinal monitoring of bone mass accumulation in healthy adolescents: evidence for a marked reduction after 16 years of age at the levels of lumbar spine and femoral neck in female subjects, *J Clin Endocrinol Metab* 75:1060, 1992.
226. **Matkovic V, Jelic T, Wardlaw GM, Ilich J, Goel PK, Wright JK, Andon MB, Smith KT, Heaney RP**, Timing of peak bone mass in Caucasian females and its implication for the prevention of osteoporosis: inference from a cross-sectional model, *J Clin Invest* 93:799, 1994.
227. **Lara-Torre E, Edwards CP, Perlaman S, Hertweck SP**, Bone mineral density in adolescent females using depot medroxyprogesterone acetate, *J Pediatr Adolesc Gynecol* 17:17, 2004.
228. **Cromer BA, Bonny AE, Stager M, Lazebnik R, Rome E, Ziegler J, Camin-Shingler K, Secic M**, Bone mineral density in adolescent females using injectable or oral contraceptives: a 24-month prospective study, *Fertil Steril* 90:2060, 2008.
229. **Kumar R, Cohen WR, Epstein FH**, Vitamin D and calcium hormones in pregnancy, *N Engl J Med* 302:1143, 1980.
230. **Sowers M, Corton G, Shapiro B, Jannausch ML, Crutchfield M, Smith ML, Randolph JF, Hollis B**, Changes in bone density with lactation, *JAMA* 269:3130, 1993.
231. **Kalkwarf HJ, Specker BL**, Bone mineral loss during lactation and recovery after weaning, *Obstet Gynecol* 86:26, 1995.
232. **Laskey MA, Prentice A**, Bone mineral changes during and after lactation, *Obstet Gynecol* 94:608, 1999.
233. **Kovacs CS**, Calcium and bone metabolism in pregnancy and lactation, *J Clin Endocrinol Metab* 86:2344, 2001.
234. **Kalkwarf HJ, Specker BL, Bianchi DC, Ranz J, Ho M**, The effect of calcium supplementation on bone density during lactation and after weaning, *N Engl J Med* 337:523, 1997.
235. **Laskey MA, Prentice A, Hanratty LA, Jarjou LM, Dibba B, Beavan SR, Cole TJ**, Bone changes after 3 mo of lactation: influence of calcium intake, breast-milk output, and vitamin D-receptor genotype, *Am J Clin Nutr* 67:685, 1998.
236. **Ritchie LD, Fung EB, Halloran BP, Turnlund JR, Van Loan MD, Cann CE, King JC**, A longitudinal study of calcium homeostasis during human pregnancy and lactation and after resumption of menses, *Am J Clin Nutr* 67:693, 1998.
237. **Polatti F, Capuzzo E, Viazzo F, Colleoni R, Klersy C**, Bone mineral changes during and after lactation, *Obstet Gynecol* 94:52, 1999.
238. **Karlsson C, Obrant KJ, Karlsson M**, Pregnancy and lactation confer reversible bone loss in humans, *Osteoporos Int* 12:828, 2001.
239. **Kojima N, Douchi T, Kosha S, Nagata Y**, Cross-sectional study of the effects of parturition and lactation on bone mineral density later in life, *Maturitas* 41:203, 2002.
240. **Cundy T, Cornish J, Evans MC, Roberts H, Reid IR**, Recovery of bone density in women who stop using medroxyprogesterone acetate, *Br Med J* 308:247, 1994.

241. **Clark MK, Sowers M, Levy B, Nichols S**, Bone mineral density loss and recovery during 48 months in first-time users of depot medroxyprogesterone acetate, *Fertil Steril* 86:1466, 2006.
242. **Kaunitz AM, Miller PD, Rice VM, Ross D, McClung MR**, Bone mineral density in women aged 25–35 years receiving depot medroxyprogesterone acetate: recovery following discontinuation, *Contraception* 74:90, 2006.
243. **Scholes D, LaCroix AZ, Ichikawa LE, Barlow WE, Ott SM**, Change in bone mineral density among adolescent women using and discontinuing depot medroxyprogesterone acetate contraception, *Arch Pediatr Adolesc Med* 159:139, 2005.
244. **Berenson AB, Rahman M, Breitkopf CR, Bi LX**, Effects of depot medroxyprogesterone acetate and 20-microgram oral contraceptives on bone mineral density, *Obstet Gynecol* 112:788, 2008.
245. **Orr-Walker BJ, Evans MC, Ames RW, Clearwater JM, Cundy T, Reid IR**, The effect of past use of the injectable contraceptive depot medroxyprogesterone acetate on bone mineral density in normal postmenopausal women, *Clin Endocrinol (Oxf)* 49:615, 1998.
246. **Murphy LJ, Murphy LC, Stead B, Sutherland RL, Lazarus L**, Modulation of lactogenic receptors by progestins in cultured human breast cancer cells, *J Clin Endocrinol Metab* 62:280, 1986.
247. **Simon WE, Pahnke VG, Holzel F**, In vitro modulation of prolactin binding to human mammary carcinoma cells by steroid hormones and prolactin, *J Clin Endocrinol Metab* 60:1243, 1985.
248. **Kelly PA, Kijane J, Postel-Vinay M-C, Edery M**, The prolactin/growth hormone receptor family, *Endocr Rev* 12:235, 1991.
249. **Garza-Flores J, Cardenas S, Rodriguez V, Cravioto MC, Diaz-Sanchez V, Perez-Palacios G**, Return to ovulation following the use of long-acting injectable contraceptives: a comparative study, *Contraception* 31:361, 1985.
250. **Pardthaisong T**, Return of fertility after use of the injectable contraceptive Depo Provera: up-dated analysis, *J Biosoc Sci* 16:23, 1984.
251. **Schwally P, Assenze J**, The effect of depo medroxyprogesterone acetate on pituitary and ovarian function, and the return of fertility following its discontinuation. A review, *Contraception* 10:181, 1974.
252. **Beksinska ME, Smit JA, Kleinschmidt I, Rees H, Farley TMM, Guidozzi F**, Detection of raised FSH levels among older women using depomedroxyprogesterone acetate and norethisterone enanthate, *Contraception* 68:339, 2003.
253. **Juliato CT, Fernandes A, Marchi NM, Castro S, Olivotti B, Bahamondes L**, Usefulness of FSH measurements for determining menopause in long-term users of depot-medroxyprogesterone acetate over 40 years of age, *Contraception* 76:282, 2007.
254. **Newton JR, d’Arcangues C, Hall PE**, A review of ‘once-a-month’ combined injectable contraceptives, *J Obstet Gynaecol* 14(Suppl 1):S1, 1994.
255. **Rosenblatt KA, Gao DL, Ray RM, Nelson ZC, Wernli KJ, Li W, Thomas DB**, Monthly injectable contraceptives and the risk of all cancers combined and site-specific cancers in Shanghai, *Contraception* 76:40, 2007.
256. **WHO Special Programme of Research, Development and Research Training in Human Reproduction, Task Force on Long-Acting Systemic Agents for Fertility Regulation**, A multicentered phase III comparative study of two hormonal contraceptive preparations given once-a-month by intramuscular injection, *Contraception* 40:531, 1989.
257. **Cuong DT, Huong M**, Comparative phase III clinical trial of two injectable contraceptive preparations, depot-medroxyprogesterone acetate and Cyclofem in Vietnamese women, *Contraception* 54:169, 1996.
258. **Hall P, Bahamondes L, Diaz J, Petta C**, Introductory study of the once-a-month, injectable contraceptive Cyclofem® in Brazil, Chile, Columbia, and Peru, *Contraception* 56:353, 1997.
259. **Garza-Flores J, Morales del Olmo A, Fuziwara JL, Figueroa JG, Alonso A, Monroy J, Perez M, Urbina-Fuentes M, Guevara SJ, Cedeno E, Barrios R, Ferman JJ, Medina LM, Velezquez E, Perez-Palacios G**, Introduction of Cyclofem® once-a-month injectable contraceptive in Mexico, *Contraception* 58:7, 1998.
260. **Kaunitz AM, Garceau RJ, Cromie MA; Lunelle Study Group**, Comparative safety, efficacy, and cycle

control of Lunelle™ monthly contraceptive injection (medroxyprogesterone acetate and estradiol cypionate injectable suspension) and Ortho-Novum® 7/7/7 oral contraceptive (Norethindrone/ethinyl estradiol triphasic), *Contraception* 60:179, 1999.

261. **Garceau RJ, Wajszczuk CJ, Kaunitz AM; Lunelle Study Group**, Bleeding patterns of women using Lunelle™ monthly contraceptive injections (medroxyprogesterone acetate and estradiol cypionate injectable suspension) compared with those of women using Ortho-Novum™ 7/7/7 (norethindrone/ethinyl estradiol triphasic) or other oral contraceptives, *Contraception* 62:289, 2000.
262. **Bahamondes L, Lavín P, Ojeda G, Petta C, Diaz J, Maradiegue E, Monteiro I**, Return of fertility after discontinuation of the once-a-month injectable contraceptive Cyclofem®, *Contraception* 55:307, 1997.
263. **Bahamondes L, Marchi NM, Nakagava HM, de Melo MLR, de Lourdes Cristofolletti M, Pellini E, Scozzafave RH, Petta C**, Self-administration with UniJect® of the once-a-month injectable contraceptive Cyclofem®, *Contraception* 56:301, 1997.
264. **Piya-Anant M, Koetsawang S, Patrasupapong N, Dinchuen P, d’Arcangues C, Piaggio G, Pinol A**, Effectiveness of Cyclofem® in the treatment of depot medroxyprogesterone acetate induced amenorrhea, *Contraception* 57:23, 1998.
265. **Kesseru EV, Aydinlik S, Etchepareborda JJ**, Multicentered, phase III clinical trial of norethisterone enanthate 50 mg plus estradiol valerate 5 mg as a monthly injectable contraceptive; final three-year report, *Contraception* 50:329, 1994.
266. **Sang GW, Shao QX, Ge RS, Chen JK, Song S, Fang KJ, He ML, Luo SY, Chen SF, Chen XB, Li MX, Wu SC, Sun GL, Zhou HE, Zhang SF, Zhu LL, Ye BL, Zhang JH, Ma FL, Jiang BY, Zhou ZQ, Dong QH, Shenm HC, Liu YX, Shao JY, Wang SX, Ming HD, Zhu ZR, Cheng HZ, Chen SH, Yu HY, Zhang ZY, Qing YN, Wang XY, Hall PE, d’Arcangues C, Snow RC**, A multicentred phase III comparative clinical trial of Mesigyna, Cyclofem, and injectable no. 1 given monthly by intramuscular injection to Chinese women. I. Contraceptive efficacy and side effects, *Contraception* 51:167, 1995.
267. **Martínez GH, Castañeda A, Correa JE**, Vaginal bleeding patterns in users of Perlutal®, a once-a-month injectable contraceptive consisting of 10 mg estradiol enanthate combined with 150 mg dihydroxyprogesterone acetophenide. A trial of 5462 woman-months, *Contraception* 58:21, 1998.
268. **Coutinho EM, Spinola P, Barbosa I, Gatto M, Tomaz G, Morais K, Yazlle ME, de Souza RN, Neto JSP, de Barros Leal W, Leal C, Hippolito SB, Abranches AD**, Multicenter, double-blind, comparative clinical study on the efficacy and acceptability of a monthly injectable contraceptive combination of 150 mg dihydroxyprogesterone acetophenide and 10 mg estradiol enanthate compared to a monthly injectable contraceptive combination of 90 mg dihydroxyprogesterone acetophenide and 6 mg estradiol enanthate, *Contraception* 55:175, 1997.
269. **Huber SC, Piotrow PT, Orlans B, Dommer G**, Intrauterine devices, *Popul Rep B* (2), 1975.
270. **Richter R**, Ein mittel zur verhütung der konzeption, *Deutsche Med Wochenschrift* 35:1525, 1909.
271. **Pust K**, Ein brauchbarer frauenschutz, *Deutsche Med Wochenschrift* 49:952, 1923.
272. **Gräfenberg E**, An intrauterine contraceptive method, In: Sanger M, Stone HM, eds. *The Practice of Contraception: Proceedings of the 7th International Birth Control Conference*, Zurich, Switzerland, Williams & Wilkins, Baltimore, 1930, p. 33.
273. **Ota T**, A study on birth control with an intra-uterine instrument, *Jpn J Obstet Gynecol* 17:210, 1934.
274. **Ishihama A**, Clinical studies on intrauterine rings, especially the present state of contraception in Japan and the experiences in the use of intra-uterine rings, *Yokohama Med Bull* 10:89, 1959.
275. **Oppenheimer W**, Prevention of pregnancy by the Graefenberg ring method: a re-evaluation after 28 years’ experience, *Am J Obstet Gynecol* 78:446, 1959.
276. **Tietze C**, Evaluation of intrauterine devices. Ninth progress report of the cooperative statistical program, *Stud Fam Plann* 1:1, 1970.
277. **Tatum HJ, Schmidt FH, Phillips DM, McCarty M, O’Leary WM**, The Dalkon shield controversy, structural and bacteriologic studies of IUD tails, *JAMA* 231:711, 1975.
278. **Kessel E**, Pelvic inflammatory disease with intrauterine device use: a reassessment, *Fertil Steril* 51:1, 1989.
279. **Eschenbach DA, Harnisch JP, Holmes KK**, Pathogenesis of acute pelvic inflammatory disease: role of

- contraception and other risk factors, *Am J Obstet Gynecol* 128:838, 1977.
280. **Kaufman DW, Shapiro S, Rosenberg L, Monson RR, Miettinen OS, Stolley PD, Slone D**, Intrauterine contraceptive device use and pelvic inflammatory disease, *Am J Obstet Gynecol* 136:159, 1980.
  281. **Kaufman DW, Watson J, Rosenberg L, Helmrich SP, Miller DR, Miettinen OS, Stolley PD, Shapiro S**, The effect of different types of intrauterine devices on the risk of pelvic inflammatory disease, *JAMA* 250:759, 1983.
  282. **Lee NC, Rubin GL, Ory HW, Burkman RT**, Type of intrauterine device and the risk of pelvic inflammatory disease, *Obstet Gynecol* 62:1, 1983.
  283. **Daling JR, Weiss NS, Metch BJ, Chow WH, Soderstrom RM, Moore DE, Spadoni LR, Stadel BV**, Primary tubal infertility in relation to the use of an intrauterine device, *N Engl J Med* 312:937, 1985.
  284. **Cramer DW, Schiff I, Schoenbaum SC, Gibson M, Belisle S, Albrecht B, Stillman RJ, Berger MJ, Wilson E, Stadel BV, Seible M**, Tubal infertility and the intrauterine device, *N Engl J Med* 312:941, 1985.
  285. **Lee NC, Rubin GL, Borucki R**, The intrauterine device and pelvic inflammatory disease revisited: new results from the Women's Health Study, *Obstet Gynecol* 72:1, 1988.
  286. **Piccinino LJ, Mosher WD**, Trends in contraceptive use in the United States: 1982–1995, *Fam Plann Perspect* 30:4, 1998.
  287. **Alan Guttmacher Institute**, Contraceptive use in the United States, Guttmacher Institute Fact Sheet: September 2016, [https://www.guttmacher.org/sites/default/files/factsheet/fb\\_contr\\_use\\_0.pdf](https://www.guttmacher.org/sites/default/files/factsheet/fb_contr_use_0.pdf)
  288. **Zipper JA, Medel M, Prage R**, Suppression of fertility by intrauterine copper and zinc in rabbits: a new approach to intrauterine contraception, *Am J Obstet Gynecol* 105:529, 1969.
  289. **Tatum HJ**, Milestones in intrauterine device development, *Fertil Steril* 39:141, 1983.
  290. **Sivin I, Tatum HJ**, Four years of experience with the TCU 380A intrauterine contraceptive device, *Fertil Steril* 36:159, 1981.
  291. **Sujuan G, Liuqu Z, Yuhao W, Feng L**, Chinese IUDs, In: Bardin CW, Mishell DR Jr, eds. *Proceedings from the Fourth International Conference on IUDs*, Butterworth-Heinemann, Boston, 1994, p. 308.
  292. **Bilian X**, Chinese experience with intrauterine devices, *Contraception* 75:S31, 2007.
  293. **Siving I**, Utility and drawbacks of continuous use of a copper T IUD for 20 years, *Contraception* 75:S70, 2007.
  294. **Sivin I, Diaz S, Pavéz M, Alvarez F, Brache V, Diaz J, Odland V, Olsson S-E, Stern J**, Two-year comparative trial of the gyne T 380 slimline and gyne T 380 intrauterine copper devices, *Contraception* 44:481, 1991.
  295. **Sivin I, Stern J; International Committee for Contraception Research**, Health during prolonged use of levonorgestrel 20 mg/d and the copper TCU 380 Ag intrauterine contraceptive devices: a multicenter study, *Fertil Steril* 61: 70, 1994.
  296. **Chi I-C**, The TCU-380A (AG), MLCu375, and Nova-T IUDs and the IUD daily releasing 20 mg levonorgestrel—four pillars of IUD contraception for the nineties and beyond?, *Contraception* 47:325, 1993.
  297. **Kurz KM, Meier-Oehlke PA**, The Cu SAFE 300 IUD, a new concept in intrauterine contraception: first year results of a large study with follow-up of 1017 acceptors, *Adv Contracept* 7:291, 1991.
  298. **Luukkainen T, Allonen H, Haukkamaa M, Lahtenmake P, Nilsson CG, Toivonen J**, Five years' experience with levonorgestrel-releasing IUDs, *Contraception* 33:139, 1986.
  299. **Sivin I, Stern J, Coutinho E, Mattos CER, El Mahgoub S, Diaz S, Pavéz M, Alvarez F, Brache V, Thevinin F, Diaz J, Faundes A, Diaz MM, McCarthy T, Mishell DR Jr, Shoupe D**, Prolonged intrauterine contraception: a seven-year randomized study of the levonorgestrel 20 mcg/day (LNg 20) and the copper T380 Ag IUDs, *Contraception* 44:473, 1991.
  300. **Toivonen J, Luukkainen T, Alloven H**, Protective effect of intrauterine release of levonorgestrel on pelvic infection: three years' comparative experience of levonorgestrel and copper-releasing intrauterine devices, *Obstet Gynecol* 77:261, 1991.
  301. **Bilian X, Liying Z, Xuling Z, Mengchun J, Luukkainen T, Allonen H**, Pharmacokinetic and pharmacodynamic studies of levonorgestrel-releasing intrauterine device, *Contraception* 41:353, 1990.
  302. **Crosignani PG, Vercellini P, Mosconi P, Oldani S, Cortesi I, De Giorgi O**, Levonorgestrel-releasing

intrauterine device versus hysteroscopic endometrial resection in the treatment of dysfunctional uterine bleeding, *Obstet Gynecol* 90:257, 1997.

303. **Kaunitz AM, Meredith S, Inki P, Kubba A, Sanchez-Ramos L**, Levonorgestrel-releasing intrauterine system and endometrial ablation in heavy menstrual bleeding. A systematic review and meta-analysis, *Obstet Gynecol* 113: 1104, 2009.
304. **Gardner FJE, Konje JC, Abrams KR, Brown LJR, Khanna S, Al-Azzawi F, Bell SC, Taylor DJ**, Endometrial protection from tamoxifen-stimulated changes by a levonorgestrel-releasing intrauterine system: a randomised controlled trial, *Lancet* 356:1711, 2000.
305. **Vercellini P, Aimi G, Panazza S, De Giorgi O, Pesole A, Crosignani PG**, A levonorgestrel-releasing intrauterine system for the treatment of dysmenorrhea associated with endometriosis: a pilot study, *Fertil Steril* 72:505, 1999.
306. **Raudaskoski TH, Lahti EI, Kauppila AJ, Apaja-Sarkkinen MA, Laatikainen TJ**, Transdermal estrogen with a levonorgestrel-releasing intrauterine device for climacteric complaints: clinical and endometrial responses, *Am J Obstet Gynecol* 172:114, 1995.
307. **Suhonen S, Holmstrom T, Lahteenmaki P**, Three-year follow-up of the use of a levonorgestrel-releasing intrauterine system in hormone replacement therapy, *Acta Obstet Gynecol Scand* 76:145, 1997.
308. **Suvanto-Luukkonen E, Kauppila A**, The levonorgestrel intrauterine system in menopausal hormone replacement therapy: five-year experience, *Fertil Steril* 72:161, 1999.
309. **Varila E, Wahlstrom T, Rauramo I**, A 5-year follow-up study on the use of a levonorgestrel intrauterine system in women receiving hormone replacement therapy, *Fertil Steril* 76:969, 2001.
310. **Raudaskoski T, Tapanainen J, Tomas E, Luotola H, Pekonen F, Ronni-Sivula H, Timonen H, Riphagen F, Laatikainen T**, Intrauterine 10 microg and 20 microg levonorgestrel systems in postmenopausal women receiving oral oestrogen replacement therapy: clinical, endometrial and metabolic responses, *Br J Obstet Gynaecol* 109:136, 2002.
311. **Hampton NR, Rees MC, Lowe DG, Rauramo I, Barlow D, Guillebaud J**, Levonorgestrel intrauterine system (LNG-IUS) with conjugated oral equine estrogen: a successful regimen for HRT in perimenopausal women, *Hum Reprod* 20:2653, 2005.
312. **Crenin MD, Jansen R, Starr RM, Gobburu J, Gopalakrishnan M, Olariu A**, Levonorgestrel release rates over 5 years with the Liletta 52-mg intrauterine system, *Contraception* 94:353, 2016.
313. **Apter D, Gemzell-Danielsson K, Hauck B, Rosen K, Zurth C**, Pharmacokinetics of two low-dose levonorgestrel-releasing intrauterine systems and effects on ovulation rate and cervical function: pooled analyses of phase II and III studies, *Fertil Steril* 101:1656, 2014.
314. **Wildemeersch D, Janssens D, Andrade A**, The Femilis LNG-IUS: contraceptive performance—an interim analysis, *Eur J Contracept Reprod Health Care* 14:103, 2009.
315. **Van Kets H, Van der Pas H, Thiery M, Wildemeersch D, Vrijens M, Van Trappen Y, Temmerman M, DePypere H, Delborge W, Dhont M, Defoort P, Schacht EH, Bártárl I, Barri P, Martinez F, Iglesias Cortit LH, Creatsas G, Shangchun W, Xiaoming C, Zuan-chong F, Yu-ming W, Andrade A, Reinprayoon D, Pizarro E**, The GyneFix® implant system for interval, postabortal and postpartum contraception: a significant advance in long-term reversible contraception, *Eur J Contracept Reprod Health Care* 2:1, 1997.
316. **Wildemeersch D, Batar I, Webb A, Gbolade BA, Delborge W, Temmerman M, Dhont M, Gillebaud J**, GyneFIX. The frameless intrauterine contraceptive implant—an update for interval, emergency and postabortal contraception, *Br J Fam Plann* 24:149, 1999.
317. **Wu S, Hu J, Wildemeersch D**, Performance of the frameless GyneFix and the TCu380A IUDs in a 3-year multicenter, randomized, comparative trial in parous women, *Contraception* 61:91, 2000.
318. **Wildemeersch D, Dhont M, Temmerman M, Delborge W, Schacht E, Thiery M**, GyneFix-LNG: preliminary clinical experience with a copper and levonorgestrel-releasing intrauterine system, *Eur J Contracept Reprod Health Care* 4:15, 1999.
319. **Wildemeersch D, Schacht E, Wildemeersch P**, Performance and acceptability of intrauterine release of levonorgestrel with a miniature delivery system for hormonal substitution therapy, contraception and treatment



in peri and postmenopausal women, *Maturitas* 44:237, 2003.

320. **Wildemeersch D, Rowe PJ**, Assessment of menstrual blood loss in women with idiopathic menorrhagia using the frameless levonorgestrel-releasing intrauterine system, *Contraception* 70:165, 2004.
321. **Wildemeersch D, Pylyser K, De Wever N, Dhont M**, Treatment of non atypical and atypical endometrial hyperplasia with a levonorgestrel-releasing intrauterine system: long-term follow-up, *Maturitas* 57:210, 2007.
322. **Sivin I**, IUDs are contraceptives, not abortifacients: a comment on research and belief, *Stud Fam Plann* 20:355, 1989.
323. **Ortiz ME, Croxatto HB**, The mode of action of IUDs, *Contraception* 36:37, 1987.
324. **Ortiz ME, Croxatto HB**, Copper-T intrauterine device and levonorgestrel intrauterine system: biological bases of their mechanism of action, *Contraception* 75:S16, 2007.
325. **Croxatto HB, Devoto L, Durand M, Ezcurra E, Larrea F, Nagle C, Ortiz ME, Vantman D, Vega M, von Hertzen H**, Mechanism of action of hormonal preparations used for emergency contraception: a review of the literature, *Contraception* 63: 112.
326. **Alvarez F, Guiloff E, Brache V, Hess R, Fernandez E, Salvatierra AM, Guerrero B, Zacharias S**, New insights on the mode of action of intrauterine contraceptive devices in women, *Fertil Steril* 49:768, 1988.
327. **Segal SJ, Alvarez-Sanchez F, Adejuwon CA, Brache De Mejla V, Leon P, Faundes A**, Absence of chorionic gonadotropin in sera of women who use intrauterine devices, *Fertil Steril* 44:214, 1985.
328. **Wilcox AJ, Weinberg CR, Armstrong EG, Canfield RE**, Urinary human chorionic gonadotropin among intrauterine device users: detection with a highly specific and sensitive assay, *Fertil Steril* 47:265, 1987.
329. **Ämmälä M, Nyman T, Strengell L, Rutanen E-M**, Effect of intrauterine contraceptive devices on cytokine messenger ribonucleic acid expression in the human endometrium, *Fertil Steril* 63:773, 1995.
330. **Critchley HO, Wang H, Jones RL, Kelly RW, Drudy TA, Gebbie AE, Buckley CH, McNeilly AS, Glasier AF**, Morphological and functional features of endometrial decidualization following long-term intrauterine levonorgestrel delivery, *Hum Reprod* 13:1218, 1998.
331. **Barbosa I, Olsson SE, Odland V, Goncalves T, Coutinho E**, Ovarian function after seven years' use of levonorgestrel IUD, *Adv Contracept* 11:85, 1995.
332. **Vessey MP, Lawless M, McPherson K, Yeates D**, Fertility after stopping use of intrauterine contraceptive device, *Br Med J* 283:106, 1983.
333. **Belhadj H, Sivin I, Diaz S, Pavéz M, Tejada A-S, Brache V, Alvarez F, Shoupe D, Breaux H, Mishell DR Jr, McCarthy T, Yo V**, Recovery of fertility after use of the levonorgestrel 20 mcg/day or copper T 380Ag intrauterine device, *Contraception* 34:261, 1986.
334. **Skjeldestadt FE, Bratt H**, Fertility after complicated and non-complicated use of IUDs. A controlled prospective study, *Adv Contracept* 4:179, 1988.
335. **Wilson JC**, A prospective New Zealand study of fertility after removal of copper intrauterine devices for conception and because of complications: a four-year study, *Am J Obstet Gynecol* 160:391, 1989.
336. **Inki P, Hurskainen R, Palo P, Ekholm E, Grenman S, Kivela A, Kujansuu E, Teperi J, Yliskoski M, Paavonen J**, Comparison of ovarian cyst formation in women using the levonorgestrel-releasing intrauterine system vs. hysterectomy, *Ultrasound Obstet Gynecol* 20:381, 2002.
337. **Lidegaard Ø, Lokkegaard E, Svendsen AL, Agger C**, Hormonal contraception and risk of venous thromboembolism: national follow-up study, *Br Med J* 339:b2890, 2009. doi:10.1136/bmj.b2890.
338. **Milsom I, Andersson K, Andersch B, Rybo G**, A comparison of flurbiprofen, tranexamic acid, and a levonorgestrel-releasing intrauterine contraceptive device in the treatment of idiopathic menorrhagia, *Am J Obstet Gynecol* 164:879, 1991.
339. **Tang GW, Lo SS**, Levonorgestrel intrauterine device in the treatment of menorrhagia in Chinese women: efficacy versus acceptability, *Contraception* 51: 231, 1995.
340. **Irvine GA, Campbell-Brown MB, Lumsden MA, Heikkila A, Walker JJ, Cameron IT**, Randomised comparative trial of the levonorgestrel intrauterine system and norethisterone for treatment of idiopathic menorrhagia, *Br J Obstet Gynaecol* 105:592, 1998.
341. **Istre O, Trolle B**, Treatment of menorrhagia with the levonorgestrel intrauterine system versus endometrial resection, *Fertil Steril* 76:304, 2001.

342. **Romer T**, Prospective comparison study of levonorgestrel IUD versus Roller-Ball endometrial ablation in the management of refractory recurrent hypermenorrhagia, *Eur J Obstet Gynecol Reprod Biol* 90:27, 2000.
343. **Hurskainen R, Teperi J, Rissanen P, Aalto A-M, Grenman S, Kivelä A, Kujansuu E, Vuorma S, Ylikoski M, Paavonen J**, Clinical outcomes and costs with the levonorgestrel-releasing intrauterine system or hysterectomy for treatment of menorrhagia. Randomized trial 5-year follow-up, *JAMA* 291:1456, 2004.
344. **Reid PC, Virtanen-Karl S**, Randomised comparative trial of the levonorgestrel intrauterine system and mefenamic acid for the treatment of idiopathic menorrhagia: a multiple analysis using total menstrual fluid loss, menstrual blood loss and pictorial blood loss assessment charts, *Br J Obstet Gynaecol* 112:1121, 2005.
345. **Busfield RA, Farquhar CM, Sowter MC, Lethaby A, Sprecher M, Yu Y, Sadler LC, Brown J, Johnson N**, A randomised trial comparing the levonorgestrel intrauterine system and thermal balloon ablation for heavy menstrual bleeding, *Br J Obstet Gynaecol* 113:257, 2006.
346. **Brown PM, Farquhar CM, Lethaby A, Sadler LC, Johnson NP**, Cost-effectiveness analysis of levonorgestrel intrauterine system and thermal balloon ablation for heavy menstrual bleeding, *Br J Obstet Gynaecol* 113:797, 2006.
347. **Shaw RW, Symonds IM, Tamizian O, Chaplain J, Mukhopadhyay S**, Randomised comparative trial of thermal balloon ablation and levonorgestrel intrauterine system in patients with idiopathic menorrhagia, *Aust N Z J Obstet Gynaecol* 47:335, 2007.
348. **Andersson J, Rybo G**, Levonorgestrel-releasing intrauterine device in the treatment of menorrhagia, *Br J Obstet Gynaecol* 97:690, 1990.
349. **Baldszi E, Wimmer-Puchinger B, Loschke K**, Acceptability of the long-term contraceptive levonorgestrel-releasing intrauterine system (Mirena): a 3-year follow-up study, *Contraception* 67:87, 2003.
350. **Gemzell-Danielsson K, Apter D, Dermout S, Faustmann T, Rosen K, Schmelter T, Merz M, Nelson A**, Evaluation of a new, low-dose levonorgestrel intrauterine contraceptive system over 5 years of use, *Eur J Obstet Gynecol Reprod Biol* 210:22, 2017.
351. **Fan G, Kang S, Ren M, Weisberg E, Lukkari-Lax E, Roth K, Shin S**, A single-arm phase III study exploring the efficacy and safety of LNG-IUS 8, a low-dose levonorgestrel intrauterine contraceptive system (total content 13.5mg), in an Asia-Pacific population, *Contraception* 95:371, 2017.
352. **Hidalgo M, Bahamondes L, Perrotti M, Diaz J, Dantas-Monteiro C, Petta C**, Bleeding patterns and clinical performance of the levonorgestrel-releasing intrauterine system (Mirena) up to two years, *Contraception* 65:129, 2002.
353. **Grigorieva V, Chen-Mok M, Tarasova M, Mikhailov A**, Use of a levonorgestrel-releasing intrauterine system to treat bleeding related to uterine leiomyomas, *Fertil Steril* 79:1194, 2003.
354. **Mercorio F, De Simone R, Di Spiezio Sardo A, Cerrota G, Bifulco G, Vancore F, Nappi C**, The effect of a levonorgestrel-releasing intrauterine device in the treatment of myoma-related menorrhagia, *Contraception* 67:277, 2003.
355. **Soysal S, Soysal M**, The efficacy of levonorgestrel-releasing intrauterine device in selected cases of myoma-related menorrhagia: a prospective controlled trial, *Gynecol Obstet Invest* 59:29, 2005.
356. **Magalães J, Aldrighi JM, De Lima GR**, Uterine volume and menstrual patterns in users of the levonorgestrel-releasing intrauterine system with idiopathic menorrhagia or menorrhagia due to leiomyomas, *Contraception* 75:193, 2007.
357. **Tasci Y, Caglar GS, Kayikcioglu F, Cengiz H, Yagci B, Gunes M**, Treatment of menorrhagia with the levonorgestrel releasing intrauterine system: effects on ovarian function and uterus, *Arch Gynecol Obstet* 280:39, 2009.
358. **Rizkalla HF, Higgins M, Kelehan P, O'Herlihy C**, Pathological findings associated with the presence of a Mirena intrauterine system at hysterectomy, *Int J Gynecol Pathol* 27:74, 2008.
359. **Fedele L, Bianchi S, Raffaelli R, Portuese A, Dorta M**, Treatment of adenomyosis-associated menorrhagia with a levonorgestrel-releasing intrauterine device, *Fertil Steril* 68:426, 1997.
360. **Cho S, Nam A, Kim H, Chay D, Park K, Cho DJ, Park Y, Lee B**, Clinical effects of the levonorgestrel-releasing intrauterine device in patients with adenomyosis, *Am J Obstet Gynecol* 198:373.e1, 2008.
361. **Sheng J, Zhang WY, Zhang JP, Lu D**, The LNG-IUS study on adenomyosis: a 3-year follow-up study on the

efficacy and side effects of the use of levonorgestrel intrauterine system for the treatment of dysmenorrhea associated with adenomyosis, *Contraception* 79:189, 2009.

362. **Kingman CE, Kadir R, Lee CA, Economides DL**, The use of levonorgestrel-releasing intrauterine system for treatment of menorrhagia in women with inherited bleeding disorders, *Br J Obstet Gynaecol* 111:1425, 2004.
363. **Schaedel ZE, Dolan G, Powell MC**, The use of the levonorgestrel-releasing intrauterine system in the management of menorrhagia in women with hemostatic disorders, *Am J Obstet Gynecol* 193:1361, 2005.
364. **Pisoni CN, Cuadrado MJ, Khamashta MA, Hunt BJ**, Treatment of menorrhagia associated with oral anticoagulation: efficacy and safety of the levonorgestrel-releasing intrauterine device (Mirena coil), *Lupus* 15:877, 2006.
365. **Lukes AS, Reardon B, Arepally G**, Use of the levonorgestrel-releasing intrauterine system in women with hemostatic disorders, *Fertil Steril* 90:673, 2007.
366. **Kilic S, Yuksel B, Doganay M, Bardakci H, Akinsu F, Uzunlar O, Mollamahutoglu L**, The effect of levonorgestrel-releasing intrauterine device on menorrhagia in women taking anticoagulant medication after cardiac valve replacement, *Contraception* 80:152, 2009.
367. **Andersson K, Odland V, Rybo G**, Levonorgestrel-releasing and copper-releasing (Nova T) IUDs during five years of use: a randomized comparative trial, *Contraception* 49:56, 1994.
368. **Petta CA, Ferriani RA, Abrao MS, Hassan D, Rosa e Silva JC, Podgaec S, Bahamondes L**, Randomized clinical trial of a levonorgestrel-releasing intrauterine system and a depot GnRH analogue for the treatment of chronic pelvic pain in women with endometriosis, *Hum Reprod* 20:1993, 2005.
369. **Lockhat FB, Emembolu JO, Konje JC**, The efficacy, side-effects and continuation rates in women with symptomatic endometriosis undergoing treatment with an intra-uterine administered progestogen (levonorgestrel): a 3-year follow-up, *Hum Reprod* 20:789, 2005.
370. **Gomes MK, Ferriani RA, Rosa e Silva JC, Japur de Sá Rosa e Silva AC, Vieira CS, Cândido dos Reis FJ**, The levonorgestrel-releasing intrauterine system and endometriosis staging, *Fertil Steril* 87:1231, 2007.
371. **Petta CA, Ferriani RA, Abrão MS, Hassan D, Rosa e Silva JC, Podgaec S, Bahamondes L**, A 3-year follow-up of women with endometriosis and pelvic pain users of the levonorgestrel-releasing intrauterine system, *Eur J Obstet Gynecol Reprod Biol* 143:128, 2009.
372. **Kesim MD, Aydin Y, Atis A, Mandiraci G**, Long-term effects of the levonorgestrel-releasing intrauterine system on serum lipids and the endometrium in breast cancer patients taking tamoxifen, *Climacteric* 11:252, 2008.
373. **Chan SS, Tam WH, Yeo W, Yu MM, Ng DP, Wong AW, Kwan WH, Yuen PM**, A randomised controlled trial of prophylactic levonorgestrel intrauterine system in tamoxifen-treated women, *Br J Obstet Gynaecol* 114:1510, 2007.
374. **Gardner FJ, Konje JC, Bell SC, Abrams KR, Brown LJ, Taylor DJ, Habiba M**, Prevention of tamoxifen induced endometrial polyps using a levonorgestrel releasing intrauterine system: long-term follow-up of a randomised control trial, *Gynecol Oncol* 114:452, 2009.
375. **Bahamondes L, Ribeiro-Huguet P, de Andrade KC, Leon-Martins O, Petta CA**, Levonorgestrel-releasing intrauterine system (Mirena) as a therapy for endometrial hyperplasia and carcinoma, *Acta Obstet Gynecol Scand* 82: 580, 2003.
376. **Vereide AB, Kaino T, Sager G, Arnes M, Ørbo A**, Effect of levonorgestrel IUD and oral medroxyprogesterone acetate on glandular and stromal progesterone receptors (PRA and PRB), and estrogen receptors (ER-alpha and ER-beta) in human endometrial hyperplasia, *Gynecol Oncol* 101:214, 2006.
377. **Wheeler DT, Bristow RE, Kurman RJ**, Histologic alterations in endometrial hyperplasia and well-differentiated carcinoma treated with progestins, *Am J Surg Pathol* 31:988, 2007.
378. **Varma R, Soneja H, Bhatia K, Ganesan R, Rollason T, Clark TJ, Gupta JK**, The effectiveness of a levonorgestrel-releasing intrauterine system (LNG-IUS) in the treatment of endometrial hyperplasia—a long-term follow-up study, *Eur J Obstet Gynecol Reprod Biol* 139:169, 2008.
379. **Haimovich S, Checa MA, Mancebo G, Fusté P, Carreras R**, Treatment of endometrial hyperplasia without atypia in peri- and postmenopausal women with a levonorgestrel intrauterine device, *Menopause* 15:1002, 2008.

380. **Ørbo A, Arnes M, Hancke C, Vereide AB, Pettersen I, Larsen K**, Treatment results of endometrial hyperplasia after prospective D-score classification: a follow-up study comparing effect of LNG-IUD and oral progestins versus observation only, *Gynecol Oncol* 111:68, 2008.
381. **Vereide AB, Arnes M, Straume B, Maltau JM, Ørbo A**, Nuclear morphometric changes and therapy monitoring in patients with endometrial hyperplasia: a study comparing effects of intrauterine levonorgestrel and systemic medroxyprogesterone, *Gynecol Oncol* 91:526, 2003.
382. **Abu J, Brown L, Ireland D**, Endometrial adenocarcinoma following insertion of the levonorgestrel-releasing intrauterine system (Mirena) in a 36-year-old woman, *Int J Gynecol Cancer* 16:1445, 2006.
383. **Kresowik J, Ryan GL, Van Voorhis BJ**, Progression of atypical endometrial hyperplasia to adenocarcinoma despite intrauterine progesterone treatment with the levonorgestrel-releasing intrauterine system, *Obstet Gynecol* 111: 547, 2008.
384. **Laurelli G, Falcone F, Gallo MS, Scala F, Losito S, Granata V, Cascella M, Greggi S**, Long-term oncologic and reproductive outcomes in young women with early endometrial cancer conservatively treated: a prospective study and literature update, *Int J Gynecol Cancer* 26:1650, 2016.
385. **United Nations Development Programme/United Nations Population Fund/World Health Organization/World Bank, Special Programme of Research, Development and Research Training in Human Reproduction**, Long-term reversible contraception. Twelve years of experience with the TCu380A and TCu220C, *Contraception* 56:341, 1997.
386. **Hidalgo MM, Hidalgo-Regina C, Bahamondes V, Monteiro I, Petta CA, Bahamondes L**, Serum levonorgestrel levels and endometrial thickness during extended use of the levonorgestrel-releasing intrauterine system, *Contraception* 80:84, 2009.
387. **Sivin I, Stern J, Diaz J, Diaz MM, Faundes A, Mahgoub SE, Diaz S, Pavéz M, Coutinho E, Mattos CER, McCarthy T, Mishell DR Jr, Shoupe D, Alvarez F, Brache V, Jimenez E**, Two years of intrauterine contraception with levonorgestrel and with copper: a randomized comparison of the TCu 380Ag and levonorgestrel 20 mcg/day devices, *Contraception* 35:245, 1987.
388. **Sivin I, Schmidt F**, Effectiveness of IUDs: a review, *Contraception* 36:55, 1987.
389. **Petta CA, Amatya R, Farr G**, Clinical evaluation of the TCu 380A IUD at six Latin American centers, *Contraception* 50:17, 1994.
390. **WHO Special Programme of Research, Development and Research Training in Human Reproduction, Task Force on the Safety and Efficacy of Fertility Regulating Methods**, The TCu 380A, TCu 220C, Multiload 250, and Nova T IUDs at 3, 5, and 7 years of use, *Contraception* 42:141, 1990.
391. **Farr G, Amatya R**, Contraceptive efficacy of the copper T 380A and copper T 200 intrauterine devices: results from a comparative clinical trial in six developing countries, *Contraception* 49:231, 1994.
392. **Rivera R, Chen-Mok M, McMullen S**, Analysis of client characteristics that may affect early discontinuation of the TCu-380A IUD, *Contraception* 60:155, 1999.
393. **Paterson H, Ashton J, Harrison-Woolrych M**, A nationwide cohort study of the use of the levonorgestrel intrauterine device in New Zealand adolescents, *Contraception* 79:433, 2009.
394. **Thonneau P, Almont T, de La Rochebrochard E, Maria B**, Risk factors for IUD failure: results of a large multicentre case-control study, *Hum Reprod* 21: 2612, 2006.
395. **WHO Special Programme of Research, Development and Research Training in Human Reproduction, Task Force on Intrauterine Devices for Fertility Regulation**, A multinational case-control study of ectopic pregnancy, *Clin Reprod Fertil* 3:131, 1985.
396. **Marchbanks PA, Annegers JE, Coulam CB, Strathy JH, Kurland LT**, Risk factors for ectopic pregnancy. A population based study, *JAMA* 259:1823, 1988.
397. **Ory HW**, Ectopic pregnancy and intrauterine contraceptive devices: new perspectives, *Obstet Gynecol* 57:2, 1981.
398. **Edelman DA, Porter CW**, The intrauterine device and ectopic pregnancy, *Contraception* 36:85, 1987.
399. **Makinen JL, Erkkola RU, Laippala PJ**, Causes of the increase in incidence of ectopic pregnancy—a study on 1017 patients from 1966 to 1985 in Turku, Finland, *Am J Obstet Gynecol* 160:642, 1989.
400. **Skjeldestad FE**, How effectively do copper intrauterine devices prevent ectopic pregnancy? *Acta Obstet*

Gynecol Scand 76:684, 1997.

401. **Sivin I**, Dose- and age-dependent ectopic pregnancy risks with intrauterine contraception, *Obstet Gynecol* 78:291, 1991.
402. **Borgatta L, Buhling KJ, Rybowski S, Roth K, Rosen K**, A multicenter, open-label, randomized phase III study comparing a new levonorgestrel intrauterine device system (LNG-IUS 8) with combined oral contraception in young women of reproductive age, *Eur J Contracept Reprod Health Care*, 21:372, 2016.
403. **Eisenberg DL, Schreiber CA, Turok DK, Teal SB, Westhoff CL, Creinin MD**, Three-year efficacy and safety of a new 52-mg levonorgestrel-releasing intrauterine system, *Contraception* 92:10, 2015.
404. **Backman T, Rauramo I, Huhtala S, Koskenvuo M**, Pregnancy during the use of levonorgestrel intrauterine system, *Am J Obstet Gynecol* 190:50, 2004.
405. **Hov GG, Skjeldestad FE, Hilstad T**, Use of IUD and subsequent fertility—follow-up after participation in a randomized clinical trial, *Contraception* 75:88, 2007.
406. **Cameron IT, Haining R, Lumsden M-A, Thomas VR, Smith SK**, The effects of mefenamic acid and norethisterone on measured menstrual blood loss, *Obstet Gynecol* 76:85, 1990.
407. **Zhao G, Minshi L, Pengdi Z, Ruhua X, Jiedong W, Renqing X**, A preliminary morphometric study on the endometrium from patients treated with indomethacin-releasing copper intrauterine device, *Hum Reprod* 12:1563, 1997.
408. **Milsom I, Andersson K, Jonasson K, Lindstedt G, Rybo G**, The influence of the Gyne-T 380S IUD on menstrual blood loss and iron status, *Contraception* 52:175, 1995.
409. **Task Force for Epidemiological Research on Reproductive Health, United Nations Development Programme/United Nations Population Fund/World Health Organization/World Bank Special Programme of Research, Development and Research Training in Human Reproduction**, Effects of contraceptives on hemoglobin and ferritin, *Contraception* 58:261, 1998.
410. **Hassan EO, El-Husseini M, El-Nahal N**, The effect of 1-year use of the CuT 380A and oral contraceptive pills on hemoglobin and ferritin levels, *Contraception* 60:101, 1999.
411. **Backman T, Huhtala S, Blom T, Luoto R, Rauramo I, Markku K**, Length of use and symptoms associated with premature removal of the levonorgestrel intrauterine system: a nation-wide study of 17,360 users, *Br J Obstet Gynaecol* 107:335, 2000.
412. **Pakarinen P, Lahteenmaki P, Rutanen EM**, The effect of intrauterine and oral levonorgestrel administration on serum concentrations of sex hormone-binding globulin, insulin and insulin-like growth factor binding protein-1, *Acta Obstet Gynecol Scand* 78:423, 1999.
413. **Morin-Papunen L, Martikainen H, McCarthy MI, Franks S, Sovio U, Hartikainen A-L, Ruokonen A, Leinonen M, Laitinen J, Järvelin M-R, Pouta A**, Comparison of metabolic and inflammatory outcomes in women who used oral contraceptives and the levonorgestrel-releasing intrauterine device in a general population, *Am J Obstet Gynecol* 199:529.e1, 2008.
414. **Backman T, Rauramo I, Jaakkola K, Inki P, Vaahtera K, Launonen A, Koskenvuo M**, Use of the levonorgestrel-releasing intrauterine system and breast cancer, *Obstet Gynecol* 106:813, 2005.
415. **Lundström E, Söderqvist G, Svane G, Azavedo E, Olovosson M, Skoog L, von Schoultz E, von Schoultz B**, Digitized assessment of mammographic breast density in patients who received low-dose intrauterine levonorgestrel in continuous combination with oral estradiol valerate: a pilot study, *Fertil Steril* 85:989, 2006.
416. **Castellsague X, Thompson WD, Dubrow R**, Intra-uterine contraception and the risk of endometrial cancer, *Int J Cancer* 54:911, 1993.
417. **Lassise DL, Savitz DA, Hamman RF, Baron AE, Brinton LA, Levines RS**, Invasive cervical cancer and intrauterine device use, *Int J Epidemiol* 20:865, 1991.
418. **Parazzini F, La Vecchia C, Negri E**, Use of intrauterine device and risk of invasive cervical cancer, *Int J Epidemiol* 21:1030, 1992.
419. **Hill DA, Weiss NS, Voigt LF, Beresford SAA**, Endometrial cancer in relation to intra-uterine device use, *Int J Cancer* 70:278, 1997.
420. **Sturgeon SR, Brinton LA, Berman ML, Mortel R, Twiggs LB, Barrett RJ, Wilbanks GD, Lurain JR**,

- Intrauterine device use and endometrial cancer risk, *Int J Epidemiol* 26:496, 1997.
421. **Benshushan A, Paltiel O, Rojansky N, Brzezinski A, Laufer N**, IUD use and the risk of endometrial cancer, *Eur J Obstet Gynecol Reprod Biol* 105:166, 2002.
  422. **Mark AS, Hricak H**, Intrauterine contraceptive devices: MR imaging, *Radiology* 162:311, 1987.
  423. **Pasquale SA, Russer TJ, Foldes R, Mezrich RS**, Lack of interaction between magnetic resonance imaging and the copper-T380A IUD, *Contraception* 55:169, 1997.
  424. **Mishell DR Jr, Bell JH, Good RG, Moyer DL**, The intrauterine device: a bacteriologic study of the endometrial cavity, *Am J Obstet Gynecol* 96:119, 1966.
  425. **Farley MM, Rosenberg MJ, Rowe PJ, Chen J-H, Meirik O**, Intrauterine devices and pelvic inflammatory disease: an international perspective, *Lancet* 339: 785, 1992.
  426. **Skouby SO, Molsted-Pedersen L, Kosonen A**, Consequences of intrauterine contraception in diabetic women, *Fertil Steril* 42:568, 1984.
  427. **Faundes A, Telles E, Cristofolletti MI, Faundes D, Castro S, Hardy E**, The risk of inadvertent intrauterine device insertion in women carriers of endocervical *Chlamydia trachomatis*, *Contraception* 58:105, 1998.
  428. **Jatlaoui TC, Simmons KB, Curtis KM**, The safety of intrauterine initiation among women with current asymptomatic cervical infections or at increased risk of sexually transmitted infections, *Contraception* 94:701, 2016.
  429. **Mehanna MTR, Rizk MA, Ramadan M, Schachter J**, Chlamydial serologic characteristics among intrauterine contraceptive device users: does copper inhibit chlamydial infection in the female genital tract? *Am J Obstet Gynecol* 171:691, 1994.
  430. **Kleinman D, Insler V, Sarov I**, Inhibition of *Chlamydia trachomatis* growth in endometrial cells by copper: possible relevance for the use of copper IUDs, *Contraception* 39:665, 1989.
  431. **Drake RW, Martins SL, Whitaker AK**, Intrauterine device use in an urban university clinic: safety of use in a population at high risk for sexually transmitted infections, *Contraception* 92:319, 2015.
  432. **Kronmal RA, Whitney CW, Mumford SD**, The intrauterine device and pelvic inflammatory disease: the Women's Health Study reanalyzed, *J Clin Epidemiol* 44:109, 1991.
  433. **Lee NC, Rubin GL, Grimes DA**, Measures of sexual behavior and the risk of pelvic inflammatory disease, *Obstet Gynecol* 77:425, 1991.
  434. **Murray S, Hickey JB, Houang E**, Significant bacteremia associated with replacement of intrauterine contraceptive device, *Am J Obstet Gynecol* 156:698, 1987.
  435. **Vu Q, Micks E, McCoy E, Prager S**, Efficacy and safety of long-acting reversible contraception in women with cardiovascular conditions, *Am J Cardiol*, 117:302, 2016.
  436. **Suri V, Aggarwal N, Kaur R, Chaudhary N, Ray P, Grover A**, Safety of intrauterine contraceptive device (copper T 200 B) in women with cardiac disease, *Contraception* 78:315, 2008.
  437. **Shoubnikova M, Hellberg D, Nilsson S, Mårdh P-A**, Contraceptive use in women with bacterial vaginosis, *Contraception* 55:355, 1997.
  438. **Jossens MOR, Schachter J, Sweet RL**, Risk factors associated with pelvic inflammatory disease of differing microbial etiologies, *Obstet Gynecol* 83: 989, 1994.
  439. **European Study Group**, Risk factors for male to female transmission of HIV, *Br Med J* 298:411, 1989.
  440. **Musicco M, Nicolosi A, Saracco A, Lazzarin A**, IUD use and man to woman sexual transmission of HIV-1, In: Bardin CW, Mishell DR Jr, eds. *Proceedings from the Fourth International Conference on IUDs*, Butterworth-Heinemann, Boston, 1994, p. 179.
  441. **Kapiga SH, Lyamuya EF, Lwihula GK, Hunter DJ**, The incidence of HIV infection among women using family planning methods in Dar-es-Salaam, Tanzania, *AIDS* 12:75, 1998.
  442. **European Study Group on Heterosexual Transmission of HIV**, Comparison of female to male and male to female transmission of HIV in 563 stable couples, *Br Med J* 304:809, 1992.
  443. **Sinei SK, Morrison CS, Sekadde-Kigundu C, Allen M, Kokonya D**, Complications of use of intrauterine devices among HIV-1-infected women, *Lancet* 351:1238, 1998.
  444. **Heikinheimo O, Lehtovirta P, Suni J, Paavonen J**, The levonorgestrel-releasing intrauterine system (LNG-

- IUS) in HIV-infected women—effects on bleeding patterns, ovarian function and genital shedding of HIV, *Hum Reprod* 21: 2857, 2006.
445. **Lehtovirta P, Paavonen J, Heikinheimo O**, Experience with the levonorgestrel-releasing intrauterine system among HIV-infected women, *Contraception* 75: 37, 2007.
  446. **Stringer EM, Kaseba C, Levy J, Sinkala M, Goldenberg RL, Chi BH, Matongo I, Vermund SH, Mwanahamuntu M, Stringer JSA**, A randomized trial of the intrauterine contraceptive device vs hormonal contraception in women who are infected with the human immunodeficiency virus, *Am J Obstet Gynecol* 197: 144.e1, 2007.
  447. **Phillips SJ, Curtis KM, Polis CB**, Effect of hormonal contraceptive methods on HIV disease progression, *AIDS* 13:787, 2013.
  448. **Ozgun MT, Batukan C, Mazicioglu MM, Serin IS, Baskol M, Ozturk A**, Intrauterine device use does not increase the incidence of anti-hepatitis C seropositivity among monogamous women in Turkey, *Contraception* 80: 261, 2009.
  449. **Sawtelle AL, Chappell NP, Miller CR**, Actinomyces-related tubo-ovarian abscess in a poorly controlled type II diabetic with a copper intrauterine device, *Mil Med* 182:1874, 2017.
  450. **Chapin DS, Sullinger JC**, A 43-year old woman with left buttock pain and a presacral mass, *N Engl J Med* 323:183, 1990.
  451. **Keebler C, Chatwani A, Schwartz R**, Actinomycosis infection associated with intrauterine contraceptive devices, *Am J Obstet Gynecol* 145:596, 1983.
  452. **Fiorino AS**, Intrauterine contraceptive device-associated actinomycotic abscess and Actinomyces detection on cervical smear, *Obstet Gynecol* 87:142, 1996.
  453. **Duguid HLD**, Actinomycosis and IUDs, *IPPF Med Bull* 17:3, 1983.
  454. **Petitti DB, Yamamoto D, Morgenstern N**, Factors associated with actinomyces-like organisms on Papanicolaou smear in users of IUDs, *Am J Obstet Gynecol* 145:338, 1983.
  455. **Merki-Feld GS, Lebeda E, Hogg B, Keller PJ**, The incidence of actinomyces-like organisms in Papanicolaou-stained smears of copper- and levonorgestrel-releasing intrauterine devices, *Contraception* 61:365, 2000.
  456. **Westhoff C**, IUDs and colonization or infection with Actinomyces, *Contraception* 75:S48, 2007.
  457. **Persson E, Holmberg K, Dahlgren S, Nielsson L**, Actinomyces israelii in genital tract of women with and without intrauterine contraception devices, *Acta Obstet Gynecol Scand* 62:563, 1983.
  458. **Yeo JK, Youm J, Kim JH, Jee BC**, Actinomyces-like organisms in cervical smears: the association with intrauterine device and pelvic inflammatory disease, *Obstet Gynecol Sci* 57:393, 2014.
  459. **Merki-Feld GS, Rosselli M, Imthurn B**, Comparison of two procedures for routine IUD exchange in women with positive Pap smears for actinomyces-like organisms, *Contraception* 77:177, 2008.
  460. **Hill GB**, Eubacterium nodatum mimics Actinomyces in intrauterine device-associated infections and other settings within the female genital tract, *Obstet Gynecol* 79:534, 1992.
  461. **Stubblefield P, Fuller A, Foster S**, Ultrasound-guided intrauterine removal of intrauterine contraceptive devices in pregnancy, *Obstet Gynecol* 72:961, 1988.
  462. **Lewit S**, Outcome of pregnancy with intrauterine device, *Contraception* 2:47, 1970.
  463. **Alviator GT Jr**, Pregnancy outcome with removal of intrauterine device, *Obstet Gynecol* 41:894, 1973.
  464. **Assaf A, Gohar M, Saad S, El-Nashar A, Abdel Aziz A**, Removal of intrauterine devices with missing tails during early pregnancy, *Contraception* 45:541, 1992.
  465. **Cohen SB, Bouaziz J, Bar-on A, Schiff E, Goldenberg M, Mashiach R**, In-office hysteroscopic extraction of intrauterine devices in pregnant patients who underwent prior ultrasound-guided extraction failure, *J Minim Invasive Gynecol*, 24:833, 2017.
  466. **Foreman H, Stadel BV, Schlesselman S**, Intrauterine device usage and fetal loss, *Obstet Gynecol* 58:669, 1981.
  467. **United Kingdom Family Planning Research Network**, Pregnancy outcome associated with the use of IUDs, *Br J Fam Plann* 15:7, 1989.
  468. **Williams P, Johnson B, Vessey M**, Septic abortion in women using intrauterine devices, *Br Med J* iv:263,

1975.

469. **Schaeffer SF, Gimovsky AC, Aly H, Mohamed MA**, Pregnancy and delivery with an intrauterine device in situ: outcomes in the National Inpatient Sample Database, *J Matern Fetal Neonatal Med* 26:1, 2017.
470. **Guillebaud J**, IUD and congenital malformation, *Br Med J* i:1016, 1975.
471. **Layde PM, Goldberg MF, Safra MJM, Oakley GP**, Failed intrauterine device contraception and limb reduction deformities: a case-control study, *Fertil Steril* 31:18, 1979.
472. **Suhonen S, Haukkamaa M, Jakobsson T, Rauramo I**, Clinical performance of a levonorgestrel-releasing intrauterine system and oral contraceptives in young nulliparous women: a comparative study, *Contraception* 69:407, 2004.
473. **Veldhuis HM, Vos AG, Lagro-Janssen ALM**, Complications of the intrauterine device in nulliparous and parous women, *Eur J Contracept Reprod Health Care* 10:82, 2004.
474. **Newton J, Tacchi D**, Long-term use of copper intrauterine devices, *Br J Fam Plann* 16:116, 1990.
475. **Haimov-Kochman R, Ackerman Z, Anteby EY**, The contraceptive choice for a Wilson's disease patient with chronic liver disease, *Contraception* 56:241, 1997.
476. **Kjos SL, Ballagh SA, La Cour M, Xiang A, Mishell DR Jr**, The copper T380A intrauterine device in women with Type II diabetes mellitus, *Obstet Gynecol* 84:1006, 1994.
477. **Sanders JN, Turok DK, Gawron LM, Law A, Wen L, Lynen R**, Two-year continuation of intrauterine devices and contraceptive implants in a mixed-payer setting: a retrospective review, *Am J Obstet Gynecol* 216:590e1, 2017.
478. **Diedrich JT, Madden T, Zhao Q, Peipert JF**, Long-term utilization and continuation of intrauterine devices, *Am J Obstet Gynecol* 213:822, 2015.
479. **Duenas JL, Albert A, Carrasco F**, Intrauterine contraception in nulligravid vs parous women, *Contraception* 53:23, 1996.
480. **Hubacher D, Lara-Ricalde R, Taylor DJ, Guerra-Infante F, Guzman-Rodriguez R**, Use of copper intrauterine devices and the risk of tubal infertility among nulligravid women, *N Engl J Med* 345:561, 2001.
481. **Doll H, Vessey M, Painter R**, Return of fertility in nulliparous women after discontinuation of the intrauterine device: comparison with women discontinuing other methods of contraception, *Br J Obstet Gynaecol* 108:304, 2001.
482. **Andersson K, Batar I, Rybo G**, Return to fertility after removal of a levonorgestrel-releasing intra-uterine device and Nova T, *Contraception* 46:575, 1992.
483. **Bastianelli C, Farris M, Lippa A, Lucantoni V, Valente A**, [Use of intrauterine device by nulliparous women. Prospective study and preliminary data], *Minerva Ginecol* 50:231, 1998.
484. **Edelman D, Van Os W**, Safety of intrauterine contraception, *Adv Contracept* 6:207, 1990.
485. **Mishell DR Jr, Roy S**, Copper intrauterine contraceptive device event rates following insertion 4 to 8 weeks post partum, *Am J Obstet Gynecol* 143:29, 1982.
486. **Zhuang L, Wang H, Yang P**, Observations of the clinical efficacies and side effects of six different timings of IUD insertions, *Chin J Obstet Gynecol* 22:350, 1987.
487. **Chi I-C, Farr G**, Postpartum IUD contraception—a review of an international experience, *Adv Contracept* 5:127, 1989.
488. **Celen S, Möröy P, Sucak A, Aktulay A, Danisman N**, Clinical outcomes of early postplacental insertion of intrauterine contraceptive devices, *Contraception* 69:279, 2004.
489. **Zhou S, Chi I-C**, Immediate postpartum IUD insertions in a Chinese hospital—a two-year follow-up, *Int J Gynaecol Obstet* 35:157, 1991.
490. **Chi I-C, Potts M, Wilkens L, Champion C**, Performance of the TCu-380A device in breastfeeding and non-breastfeeding women, *Contraception* 39:603, 1989.
491. **Andersson K, Ryde-Blomqvist E, Lindell K, Odland V, Milsom I**, Perforations with intrauterine devices. Report from a Swedish survey, *Contraception* 57:251, 1998.
492. **White MK, Ory HW, Rooks JB, Rochat RW**, Intrauterine device termination rates and the menstrual cycle day of insertion, *Obstet Gynecol* 55:220, 1980.
493. **Korjamo R, Mentula M, Heikinheimo O**, Expulsions and adverse events following immediate and later



insertion of a levonorgestrel-releasing intrauterine system after medical termination of late first- and second-trimester pregnancy: a randomized controlled trial, *BJOG* 124:1965, 2017.

494. **Querido L, Ketting E, Haspels AA**, IUD insertion following induced abortion, *Contraception* 31:603, 1985.
495. **Reeves MF, Smith KJ, Creinin MD**, Contraceptive effectiveness of immediate compared with delayed insertion of intrauterine devices after abortion: a decision analysis, *Obstet Gynecol* 110:1286, 2007.
496. **Rabin JM, Spitzer M, Dwyer AT, Kaiser IM**, Topical anesthesia for gynecologic procedures, *Obstet Gynecol* 73:1040, 1984.
497. **Anteby E, Revel A, Ben-Chetrit A, Rosen B, Tadmor O, Yagel S**, Intrauterine device failure: relation to its location within the uterine cavity, *Obstet Gynecol* 81:112, 1993.
498. **Stanback J, Grimes D**, Can intrauterine device removals for bleeding or pain be predicted at a one-month follow-up visit? A multivariate analysis, *Contraception* 58:357, 1998.
499. **Grimes DA, Schulz KF**, Antibiotic prophylaxis for intrauterine contraceptive device insertion, *Cochrane Database Syst Rev* (2):CD001327, 2000.
500. **Sachs BP, Gregory K, McArdle C, Pinshaw A**, Removal of retained intrauterine contraceptive devices in pregnancy, *Am J Perinatol* 9:139, 1992.
501. **Gorsline J, Osborne N**, Management of the missing intrauterine contraceptive device: report of a case, *Am J Obstet Gynecol* 153:228, 1985.
502. **Adoni A, Chetrit AB**, The management of intrauterine devices following uterine perforation, *Contraception* 43:77, 1991.
503. **Markovitch O, Klein Z, Gidoni Y, Holzinger M, Beyth Y**, Extrauterine mislocated IUD: is surgical removal mandatory? *Contraception* 66:105, 2002.
504. **Gronlund B, Blaabjerg J**, Serious intestinal complication five years after insertion of a Nova-T, *Contraception* 44:517, 1991.

---

# Barrier Methods of Contraception and Withdrawal

Barrier methods of contraception are the oldest and the most widely used contraceptive techniques throughout recorded history. These are also the only contraceptive methods that protect against sexually transmitted infections (STIs). A need for sexual safety has brought new respect and modern developments to the condom, while other barrier methods continue to serve appropriate couples. Withdrawal is also an ancient method of contraception that deserves understanding and appreciation.

# HISTORY OF BARRIER METHODS

---

The use of vaginal contraceptives is probably as ancient as *Homo sapiens*. References to sponges and plugs appear in the earliest of writings. However, the diaphragm and the cervical cap were not invented until the late 1800s, the same time period that saw the beginning of investigations with spermicidal agents.

Intravaginal contraception was widespread in isolated cultures throughout the world. The Japanese used balls of bamboo paper, Islamic women used willow leaves, and women in the Pacific Islands used seaweed. References can be found throughout ancient writings to sticky plugs, made of gum-like substances, to be placed in the vagina prior to intercourse. In preliterate societies, an effective method had to have been the result of trial and error, with some good luck thrown in. Contraceptive knowledge is believed to have spread through communication of these traditions through these isolated societies. The social and technical circumstances of ancient times conspired to make communication of information very difficult. But even when knowledge was lacking, the desire to prevent conception was not, hence the widespread use of potions, body movements, and amulets, all of which can be best described as magic.

Egyptian papyri dating from 1850 B.C. refer to plugs of honey, gum, acacia, and crocodile dung. The descriptions of contraceptive techniques by Soranus are viewed as the best in history until modern times.<sup>1</sup> Soranus of Ephesus lived from 98 to 138 and has often been referred to as the greatest gynecologist of antiquity. He studied in Alexandria and practiced in Rome. His great text was lost for centuries and was not published until 1838. Soranus gave explicit directions regarding how to make concoctions that probably combined a barrier with spermicidal action. He favored making pulps from nuts and fruits (probably very acidic and spermicidal) and advocated the use of soft wool placed at the cervical os. He described up to 40 different combinations.

The earliest penis protectors were just that, intended to provide prophylaxis against infection. In 1564, Gabriello Fallopius, one of the early authorities on syphilis, described a linen condom that covered the glans penis. The linen condom of Fallopius was followed by full covering with animal skins and intestines, but use for contraception cannot be dated to earlier than the 1700s. By 1800, condoms were available at brothels throughout Europe. The vulcanization of rubber revolutionized contraception. Vulcanization of rubber dates to 1844, and, by 1850, rubber condoms were available in the United States. The introduction of liquid latex and automatic machinery ultimately made reliable condoms both plentiful and affordable.

Diaphragms first appeared in publications in Germany in the 1880s. A practicing German gynecologist C. Haase wrote extensively about his diaphragm, using the pseudonym Wilhelm P. J. Mensinga. The Mensinga diaphragm retained its original

design with little change until modern times.

The cervical cap was available for use before the diaphragm. A New York gynecologist E. B. Foote wrote a pamphlet describing its use around 1860. By the 1930s, the cervical cap was the most widely prescribed method of contraception in Europe. Its use was not as widespread in the United States; some blame the more restrictive attitude toward sexuality as an explanation for why American women had difficulty learning self-insertion techniques.

Scientific experimentation with chemical inhibitors of sperm began in the 1800s. By the 1950s, more than 90 different spermicidal products were being marketed, and some of them were used in the first efforts to control fertility in India.<sup>2</sup> With the availability of the intrauterine device and the development of oral contraception in the 1960s, interest in spermicidal agents waned, and the number of products declined.

In the last decades of the 1800s, condoms, diaphragms, pessaries, and douching syringes were widely advertised; however, they were not widely used. It is only since 1900 that the knowledge and application of contraception have been democratized, encouraged, and promoted. And it is only since 1960 that contraception teaching and practice became part of academic medicine but not without difficulty. In the 1960s, Duncan Reid, chair of obstetrics at Harvard Medical School, organized and cared for women in a clandestine clinic for contraception. In “Dr. Reid’s Clinic” at the Boston Lying-In Hospital, women were able to receive contraceptives not available elsewhere in the city ([Table 24.1](#)).

## **TABLE 24.1 Failure Rates During the First Year of Use, United States<sup>3,4,5</sup>**

Method	Percent of Women with Pregnancy	
	Lowest Expected	Typical
No method	85%	85%
Combination pill	0.3%	8.7%
Progestin only	0.5%	3.0%
IUDs		
Levonorgestrel IUD	0.1%	0.1%
Copper T 380A	0.6%	1.0%
Implant	0.05%	1.0%
Injectable		
3 month	0.3	0.3%
1 month	0.05	3.0%
Patch	0.3	8.0%
Vaginal ring	0.3	8.0%
Female sterilization	0.5%	0.7%
Male sterilization	0.1%	0.2%
Periodic abstinence		25.3%
Calendar	9.0%	
Ovulation method	3.0%	
Symptothermal	2.0%	
Postovulation	1.0%	
Spermicides	18.0%	29.0%
Cervical cap		
Parous women	26.0%	32.0%
Nulliparous women	9.0%	16.0%
Sponge		
Parous women	20.0%	32.0%
Nulliparous women	9.0%	16.0%
Diaphragm and spermicides	6.0%	16.0%
Condom		
Male	2.0%	17.4%
Female	5.0%	27.0%
Withdrawal	4.0%	18.4%

In 1961, C. Lee Buxton, chair of obstetrics and gynecology at Yale Medical School, and Estelle Griswold, the 61-year-old executive director of Connecticut Planned Parenthood, opened four Planned Parenthood clinics in New Haven, in a defiant move against the current Connecticut law. In an obvious test of the Connecticut law, Buxton and Griswold were arrested at the Orange Street clinic, in a prearranged scenario scripted by Buxton and Griswold at the invitation of the district attorney. They were found guilty and fined \$100, but imprisonment was deferred because the obvious goal was a decision by the United States Supreme Court. Buxton was forever rankled by the trivial amount of the fine. On June 7, 1965, the Supreme Court voted 7–2 to overturn the Connecticut law on the basis of a constitutional right of privacy. It was not until 1972 and 1973 that the last state laws prohibiting the distribution of contraceptives were overthrown.

# RISKS AND BENEFITS COMMON TO ALL BARRIER METHODS

---

Barrier methods (condoms and diaphragms) provide protection (about a 50% reduction) against STIs and pelvic inflammatory disease (PID).<sup>6,7,8,9,10</sup> This includes infections due to chlamydia, gonorrhea, trichomonas, herpes simplex, and cytomegalovirus. Only the condom has been proven to prevent human immunodeficiency virus (HIV) infection. STI protection has a beneficial impact on the risk of tubal infertility and ectopic pregnancy.<sup>8,11</sup> There have been no significant clinical studies on STIs and cervical caps or the female condom, but these methods seem to be at least as effective as male condom use in preventing STI transmission.<sup>12,13</sup> Women who have never used barrier methods of contraception are almost twice as likely to develop cancer of the cervix.<sup>11,14</sup> The risk of toxic shock syndrome is increased with female barrier methods, but the actual incidence is so rare that this is not a significant clinical consideration.<sup>15</sup> Women who have had toxic shock syndrome, however, should be advised to avoid barrier methods.

## **Barrier Methods and Preeclampsia**

An initial case-control study indicated that methods of contraception that prevented exposure to sperm were associated with an increased risk of preeclampsia.<sup>16</sup> This was not confirmed in a careful analysis of two large prospective pregnancy studies.<sup>17</sup> This latter conclusion was more compelling in that it was derived from a large, prospective, cohort database.



# THE DIAPHRAGM

---

The first effective contraceptive method under a woman's control was the vaginal diaphragm. Distribution of diaphragms led to Margaret Sanger's arrest in New York City in 1918. By 1940, one-third of contracepting American couples were using the diaphragm. This decreased to 10% by 1965 after the introduction of oral contraceptives and intrauterine devices and fell to about 1.9% in 1995, and today, diaphragm use has nearly disappeared in the United States.<sup>18</sup>

# Efficacy

Failure rates for diaphragm users vary from as low as 2% per year of use to a high of 23%. The typical use failure rate after 1 year of use is 16%.<sup>3,4,5</sup> Older, married women with longer use achieve the highest efficacy, but young women can use diaphragms very successfully if they are motivated and properly counseled. There have been no adequate studies to determine whether efficacy is different with and without spermicides.<sup>19</sup>

## Side Effects

The diaphragm is a safe method of contraception that rarely causes even minor side effects. Occasionally, women report vaginal irritation due to the latex rubber or the spermicidal jelly or cream used with the diaphragm. Less than 1% discontinue diaphragm use for these reasons. Urinary tract infections are two- to threefold more common among diaphragm users than among women using oral contraception.<sup>20,21</sup> Possibly, the rim of the diaphragm presses against the urethra and causes irritation that is perceived as infectious in origin, or true infection may result from touching the perineal area or from incomplete emptying of the bladder. It is more probable that spermicides used with the diaphragm can increase the risk of bacteriuria with *Escherichia coli*, perhaps due to an alteration in the normal vaginal flora.<sup>22</sup> Postcoital antibiotics can be prescribed for women with recurrent urinary tract infections that are associated with sexual activity. Postcoital prophylaxis is effective, using trimethoprim sulfamethoxazole (1 tablet postcoitus), nitrofurantoin (50 or 100 mg postcoitus), or cephalexin (250 mg postcoitus).

Improper fitting or prolonged retention (beyond 24 hours) can cause vaginal abrasion or mucosal irritation. There is no link between the normal use of diaphragms and the toxic shock syndrome.<sup>23</sup> It makes sense, however, to minimize the risk of toxic shock by removing the diaphragm after 24 hours and during menses.

# Benefits

Diaphragm use reduces the incidence of cervical gonorrhea, trichomonas, and chlamydia,<sup>24</sup> PID,<sup>8,25</sup> and tubal infertility.<sup>6,11</sup> There are no data, as of yet, regarding the effect of diaphragm use on the transmission of the acquired immunodeficiency syndrome (AIDS) virus HIV, but because the vagina remains exposed, the diaphragm is unlikely to protect against HIV. A clinical trial demonstrated no added benefit with a diaphragm against HIV when used with condoms.<sup>26</sup> An important advantage of the diaphragm is low cost. Diaphragms are durable and with proper care can last for several years.

# Choice and Use of the Diaphragm

There are three major types of latex diaphragms, and most manufacturers produce them in sizes ranging from 50 to 105 mm diameter, in increments of 2.5–5 mm. Most women use sizes between 65 and 80 mm. The latex diaphragm made with a flat metal spring or a coil spring remains in a straight line when pinched at the edges. This type is suitable for women with good vaginal muscle tone and an adequate recess behind the pubic arch. However, many women find it difficult to place the posterior edge of these flat diaphragms into the posterior cul-de-sac and over the cervix. Arcing diaphragms are easier to use for most women. They come in two types. The All-Flex type bends into an arc no matter where around the rim the edges are pinched together. The hinged type must be pinched between the hinges to form a symmetrical, narrow arc and may be easier for some women to insert. The arcing diaphragms allow the posterior edge of the diaphragm to slip more easily past the cervix and into the posterior cul-de-sac. Women with poor vaginal muscle tone, cystocele, rectocele, a long cervix, or an anterior cervix of a retroverted uterus use arcing diaphragms more successfully.

For women or their partners with latex allergies, the SILCS diaphragm is a silicone barrier used with a contraceptive gel.<sup>27</sup> It comes in one size that fits most women, and, therefore, interaction with a clinician and the requirement for fitting can be avoided. The Milex Wide-Seal diaphragm is also made of silicone and comes in eight sizes that require fitting.

## Fitting

Successful use of a diaphragm depends on proper fitting. The clinician must have aseptic fitting rings or the diaphragms themselves available in all diameters. These devices should be scrupulously disinfected by soaking in a bleach solution. At the time of the pelvic examination, the middle finger is placed against the vaginal wall and the posterior cul-de-sac, while the hand is lifted anteriorly until the pubic symphysis abuts the index finger. This point is marked with the examiner's thumb to approximate the diameter of the diaphragm. The corresponding fitting ring or diaphragm is inserted, and the fit is assessed by both clinician and patient.

If the diaphragm is too tightly pressed against the pubic symphysis, a smaller size is selected. If the diaphragm is too loose (comes out with a cough or bearing down), the next larger size is selected. After a good fit is obtained, the diaphragm is removed by hooking the index finger under the rim behind the symphysis and pulling. It is important to instruct the patient in these procedures during and after the fitting. The patient should then insert the diaphragm, practice checking for proper placement, and attempt removal.

## **Timing**

Diaphragm users need additional instruction about the timing of diaphragm use in relation to sexual intercourse and the use of spermicide. None of this advice has been rigorously assessed in clinical studies; therefore, these recommendations represent the consensus of clinical experience.

The diaphragm should be inserted no longer than 6 hours prior to sexual intercourse. About a tablespoonful of spermicidal cream or jelly should be placed in the dome of the diaphragm prior to insertion, and some of the spermicide should be spread around the rim with a finger. The diaphragm should be left in place for approximately 6 hours (but no more than 24 hours) after coitus. Additional spermicide should be placed in the vagina before each additional episode of sexual intercourse while the diaphragm is in place.

## **Reassessment**

Weight loss, weight gain, vaginal delivery, and even sexual intercourse can change vaginal caliber. The fit of a diaphragm should be assessed every year at the time of the regular examination.

## **Care of the Diaphragm**

After removal, the diaphragm should be washed with soap and water, rinsed, and dried. Powders of any sort should not be applied to the diaphragm. It is wise to use water to periodically check for leaks. Diaphragms should be stored in a cool and dark location.

# THE CERVICAL CAP

---

The cervical cap was popular in Europe long before its reintroduction into the United States. Currently, the only cervical cap available in the United States is the FemCap. The FemCap is made of nonallergenic silicone rubber and is shaped like a sailor's hat, a design that allows a snug fit over the cervix and in the vaginal fornices and provides a "brim" for easy removal.<sup>28</sup> There are three sizes, one for nulliparous women and larger sizes for women who have had a vaginal delivery. In a randomized trial, the pregnancy rate with FemCap was nearly twofold higher compared with a diaphragm.<sup>29</sup>

Other cervical caps available elsewhere, such as the latex Prentif cervical cap, have been shown in U.S. trials to be about as effective as the diaphragm but somewhat harder to fit and more difficult to insert (it must be placed precisely over the cervix).<sup>30,31</sup> Efficacy is significantly reduced in parous women.

Cervical caps have several advantages over the diaphragm. They can be left in place for a longer time (up to 48 hours), and they need not be used with a spermicide. However, a tablespoonful of spermicide placed in the cap before application is reported to increase efficacy (to a 6% failure rate in the first year) and to prolong wearing time by decreasing the incidence of foul-smelling discharge (a common complaint after 24 hours).<sup>31</sup>

The size of the cervix varies considerably from woman to woman, and the cervix changes in individual women in response to pregnancy or surgery. Proper fitting can be accomplished in about 80% of women. Women with a cervix that is too long or too short, or with a cervix that is far forward in the vagina, may not be suited for cap use. However, women with vaginal wall or pelvic relaxation, who cannot retain a diaphragm, may be able to use the cap.

Those women who can be fitted with a cervical cap must first learn how to identify the cervix and then how to slide the cap into the vagina, up the posterior vaginal wall and onto the cervix. After insertion and after each act of sexual intercourse, the cervix should be checked to make sure that it is covered.

The cervical cap must be left in place for at least 8 hours after sexual intercourse in order to ensure that no motile sperm are left in the vagina. To remove the cap, pressure must be exerted with a finger tip to break the seal. The finger is hooked over the cap rim to pull it out of the vagina. Bearing down or squatting or both can help to bring the cervix within reach of the finger.

The most common cause of failure is dislodgment of the cap from the cervix during sexual intercourse. There is no evidence that cervical caps cause toxic shock syndrome or dysplastic changes in the cervical mucosa.<sup>32</sup> It seems likely (although not yet

documented) that cervical caps would provide the same protection from STIs as the diaphragm.

Lea's Shield is a vaginal barrier contraceptive composed of silicone.<sup>33,34</sup> This soft, pliable device comes in one size and fits over the cervix, held in place by the pressure of the vaginal wall around it. There is a collapsible valve that communicates with a 9-mm opening in the bowl that fits over the cervix. This valve allows equalization of air pressure during insertion and drainage of cervical secretions and discharge, permitting a snug fit over the cervix. A thick U-shaped loop attached to the anterior side of the bowl is used to stabilize the device during insertion and for removal. The thicker part of the device is shaped to fill the posterior fornix, thus contributing to its placement and stability over the cervix. The addition of a spermicide, placed in the bowl, is recommended. Lea's Shield is designed to remain in place for 48 hours after intercourse. Pregnancy rates are similar to other barrier methods, and no serious adverse effects have been reported.<sup>35</sup>

Ovés is a silastic cervical cap that is available in three sizes, with a loop for insertion and removal. Studies are limited to very small numbers of women, and there are no meaningful data on efficacy.<sup>36</sup>



# THE CONTRACEPTIVE SPONGE

---

The vaginal contraceptive sponge is a sustained-release system for a spermicide. The sponge also absorbs semen and blocks the entrance to the cervical canal. The “Today” sponge is a dimpled polyurethane disc impregnated with 1 g of nonoxynol-9. Approximately 20% of the nonoxynol-9 is released over the 24 hours that the sponge is left in the vagina. “Protectaid” is a polyurethane sponge available in Canada and Hong Kong (it also can be purchased over the Internet) that contains three spermicides and a dispersing gel.<sup>37</sup> The spermicidal agents are sodium cholate, nonoxynol-9, and benzalkonium chloride. This combination exerts antiviral actions in vitro.<sup>38</sup> The dispersing agent, polydimethylsiloxane, forms a protective coating over the entire vagina, providing sustained protection.

To insert, the Today sponge is moistened with water (squeezing out the excess) and placed firmly against the cervix. There should always be a lapse of at least 6 hours after sexual intercourse before removal, even if the sponge has been in place for 24 hours before intercourse (maximal wear time, therefore, is 30 hours). It can be inserted immediately before sexual intercourse or up to 24 hours beforehand. It is removed by hooking a finger through the ribbon attached to the back of the sponge. The Protectaid sponge can be inserted up to 12 hours before intercourse, and it is easier to remove than the Today sponge. Obviously, the sponge is not a good choice for women with anatomic changes that make proper insertion and placement difficult.

In most studies, the effectiveness of the sponge exceeds that of foams, jellies, and tablets, but it is lower than that associated with diaphragm or condom use.<sup>5,39,40,41</sup> Some studies indicated failure rates that were twice as high in parous women, suggesting that one size may not fit all users.<sup>42</sup>

Discontinuation rates are generally higher among sponge users, compared with diaphragm and spermicide use. For some women, however, the sponge is preferred because it provides continuous protection for 24 hours regardless of the frequency of coitus. In addition, it is easier to use and less messy.

Side effects associated with the sponge include allergic reactions in about 4% of users. Another 8% complain of vaginal dryness, soreness, or itching. Some women find removal difficult. There is no risk of toxic shock syndrome, and, in fact, the nonoxynol-9 retards staphylococcal replication and toxin production. There has been some concern that the sponge may damage the vaginal mucosa and enhance HIV transmission.<sup>43</sup> Women using the sponge have lower rates of infection with gonorrhea, trichomonas, and chlamydia.<sup>8</sup>

# SPERMICIDES

---

Jellies, creams, foams, melting suppositories, foaming tablets, foaming suppositories, and soluble films are used as vehicles for chemical agents that inactivate sperm in the vagina before they can move into the upper genital tract. Some are used together with diaphragms, caps, and condoms, but even used alone, they can provide protection against pregnancy.

Various chemicals and a wide array of vehicles have been used vaginally as contraceptives for centuries. The first commercially available spermicidal pessaries were made in England in 1885 of cocoa butter and quinine sulfite. These or similar materials were used until the 1920s when effervescent tablets that released carbon dioxide and phenyl mercuric acetate were marketed. Modern spermicides, introduced in the 1950s, contain surface active agents that damage the sperm cell membranes. The agents currently used are nonoxynol-9, octoxynol-9, benzalkonium chloride, and menfegol. Most preparations contain 60–100 mg of these agents in each vaginal application, with concentrations ranging from 2% to 12.5% ([Table 24.2](#)).

## TABLE 24.2 Representative Products

---

Vaginal contraceptive film

---

- VCF (70 mg nonoxynol-9)

Foams

- Delfen (nonoxynol-9, 12.5%)
  - Emko (nonoxynol-9, 8%)
  - Koromex (nonoxynol-9, 12.5%)
- 

Jellies and creams

- Conceptrol (nonoxynol-9, 4%)
  - Delfen (nonoxynol-9, 12.5%)
  - Gynol II (nonoxynol-9, 3%)
  - Ramses (nonoxynol-9, 5%)
  - Koromex jelly (nonoxynol-9, 3%)
- 

**Suppositories**

- Encare (nonoxynol-9, 2.27%)
  - Koromex inserts (nonoxynol-9, 125 mg)
  - Semicid (nonoxynol-9, 100 mg)
- 

“Advantage 24” is a contraceptive gel that adheres to the vaginal mucosa and provides longer availability of nonoxynol-9; it is intended to be effective for 24 hours. Although available without prescription, adequate clinical trial data are not available. Allendale-N9 is a vaginal contraceptive film (VCF) that contains more nonoxynol-9 than VCF.<sup>44</sup> An Allendale film has also been developed that contains benzalkonium chloride instead of nonoxynol-9.<sup>45</sup> In addition to spermicidal activity, benzalkonium chloride is microbicidal and demonstrates activity against HIV.<sup>46</sup> Benzalkonium chloride is available for contraceptive use in the form of a suppository, in a sponge, or as a cream in several countries.

Although in vitro studies have demonstrated that spermicides kill or inactivate most STI pathogens, including HIV, it cannot be said that spermicides provide protection against STIs. Spermicides have been reported to prevent HIV seroconversion as well as

to have no effect; therefore, spermicides by themselves cannot be counted on for protection against HIV.<sup>45,46,47,48,49</sup> In a controlled, clinical trial in female sex workers, nonoxynol-9 failed to protect against HIV transmission.<sup>50</sup> Clinical studies have indicated reductions in the risk of gonorrhea,<sup>51,52,53</sup> pelvic infections,<sup>19</sup> and chlamydial infection.<sup>52,54</sup> However, these studies probably reflected condom use. In trials with a placebo, nonoxynol-9 provided no protection against gonorrhea or chlamydia.<sup>50,54,55,56</sup> Indeed, there is concern that frequent spermicide use may irritate the vagina and enhance HIV transmission.<sup>46</sup> Because of this concern, condom makers discontinued the production of condoms lubricated with nonoxynol-9. There is little difference in the incidence of trichomoniasis, candidiasis, or bacterial vaginosis among spermicide users.<sup>57</sup> **The best evidence indicates that spermicides do not provide additional protection against STIs over that associated with condoms; therefore, spermicides should not be used without condoms if a primary objective is to prevent infection with HIV, gonorrhea, or chlamydia.**

# Efficacy

Efficacy of spermicides in different studies ranges from less than 1% failure to nearly one-third in the first year of use. Failure rates of approximately 20–25% during a year's use are most typical.<sup>4,58</sup> A randomized trial comparing vaginal contraceptive film (72 mg nonoxynol-9) with Conceptrol foaming tablets (100 mg nonoxynol-9) recorded similar 6-month pregnancy rates (24.9% with the film and 28.0% with the tablet).<sup>58</sup> A randomized assessment of the various products concluded that a dose of 52.5 mg nonoxynol-9 was less effective (22% pregnancy rate in 6 months) than those containing 100 or 150 mg (about a 15% pregnancy rate in 6 months; intermediate doses were not tested).<sup>59</sup> These are very high rates, amounting to approximately 30–40% for 1 year of use. **Although better than no method, spermicides alone should not be recommended for contraception unless method failure and pregnancy are acceptable.**

Spermicides require application 10–30 minutes prior to sexual intercourse. Jellies, creams, and foams remain effective for as long as 8 hours, but tablets and suppositories are good for less than 1 hour. If ejaculation does not occur within the period of effectiveness, the spermicide should be reapplied. Reapplication should take place each coital episode.

**Vaginal postcoital douches are ineffective contraceptives even if they contain spermicidal agents. Postcoital douching is too late to prevent the rapid ascent of sperm (within seconds) to the fallopian tubes.**

# **Advantages**

Spermicides are relatively inexpensive and widely available in many retail outlets without prescription. This makes spermicides popular among adolescents and others who have infrequent or unpredictable sexual intercourse. In addition, spermicides are simple to use.

## Side Effects

No serious side effects or safety problems have arisen in all the years that spermicides have been used. The only serious question raised was that of a possible association between spermicide use and congenital abnormalities or spontaneous miscarriages. Epidemiologic analyses, including a meta-analysis, concluded that there is insufficient evidence to support these associations.<sup>60,61,62</sup> Spermicides are not absorbed through the vaginal mucosa in concentrations high enough to have systemic effects.<sup>63</sup> Vaginal and cervical mucosal damage (deepithelialization without inflammation) has been observed with nonoxynol-9, and the overall impact on HIV transmission, although unknown, is of concern.<sup>64,65</sup>

The principal minor problem is allergy that occurs in 1–5% of users, related to either the vehicle or the spermicidal agent. Using a different product often solves the problem. Spermicide users also have an altered vaginal flora promoting the colonization of *E. coli*, leading to a greater susceptibility to urinary tract infections as noted with diaphragm/spermicide users.<sup>22,66</sup>

# The Search for Contraceptives to Prevent STIs

For the last two decades, extensive research has been devoted to the development of contraceptive microbicides to prevent STIs, especially HIV. The ideal agent would be a topical microbicide that would prevent infection and be spermicidal. Any new agent must match the latex condom, which is nearly 100% effective in blocking bacteria and viruses. The road is long, extending from in vitro work to clinical application. An acceptable agent must avoid damage to vaginal epithelial cells and disruption of vaginal flora, and the delivery system must be user-friendly. Carraguard, a microbicide that contains carrageenan, a substance derived from seaweed, is a good example of the frustration in this area. After extensive development by the Population Council, a large, long-term phase 3 clinical trial in South Africa concluded that Carraguard did not prevent vaginal transmission of HIV.<sup>67</sup> Similarly, BufferGel, a microbicide designed to maintain vaginal acidity after ejaculation, and ProGel2000, a microbicide designed to block HIV entry into susceptible cells, were shown to be safe and effective in phase 1 clinical trials,<sup>68,69</sup> but were proven ineffective at preventing HIV transmission in a randomized controlled trial.<sup>70</sup> Acidform, a new spermicidal gel, is awaiting efficacy trials.<sup>71</sup>



# CONDOMS

---

Although awareness of condoms as an effective contraceptive method as well as a protector against STIs has increased tremendously in recent years, a great deal remains to be accomplished to reach the appropriate level of condom use. Contraceptive efficacy and STI prevention must be linked together and publicly promoted. The male condom is the only contraceptive proven to prevent HIV infection.

**There are three specific goals: correct use, consistent use, and affordable, easy availability.** Various types of condoms are available. Most are made of latex; polyurethane and silicone rubber condoms are also now manufactured. “Natural skin” (lamb’s intestine) condoms are still obtainable (about 1% of sales). Latex condoms are 0.3–0.8 mm thick. Sperm that are 0.003 mm in diameter cannot penetrate condoms. The organisms that cause STIs and AIDS also do not penetrate latex condoms, but they can penetrate condoms made from the intestine.<sup>72,73</sup> Evidence indicates that condom use (latex) also prevents transmission of human papillomavirus (HPV).<sup>74</sup> The use of spermicides or spermicide-coated condoms increases the incidence of E. coli bacteriuria and urinary tract infections due to either E. coli or Staphylococcus saprophyticus because of the spermicide-induced alteration in vaginal flora.<sup>22,75</sup> Consistent use of condoms when one partner is HIV seropositive is highly effective in preventing HIV transmission; there was no seroconversion in 124 couples who used condoms consistently compared with 12.7% conversion after 24 months in couples with inconsistent use.<sup>76,77</sup> Women who are partners of condom users are less likely to be HIV positive.<sup>78</sup> An evaluation of the world’s literature concluded that consistent use of condoms provides protection against HIV to a degree comparable to condom efficacy in preventing pregnancy (reflecting some inconsistent use and other routes of transmission).<sup>77</sup> In addition, condoms protect against transmission of the herpes simplex virus from infected men to women.<sup>79</sup>

Polyurethane condoms are expected to protect against STIs and HIV, based on in vitro efficacy as a barrier to bacteria and viruses. They are odorless, may have greater sensitivity, and are resistant to deterioration from storage and lubricants. Those individuals with latex allergy can use polyurethane condoms. Unfortunately, in a randomized, well-designed study, the polyurethane condom had a sixfold higher breakage rate than latex condoms, and another study comparing latex and polyurethane condoms found a higher pregnancy rate with the polyurethane condom.<sup>80,81</sup>

Condoms can be straight or tapered, smooth or ribbed, colored or clear, lubricated or nonlubricated. These are all marketing ventures aimed at attracting individual notions of pleasure and enjoyment.<sup>82</sup> An often repeated concern is the alleged reduction in

penile glans sensitivity that accompanies condom use.<sup>83</sup> This has never been objectively studied. A clinician can overcome this objection by advocating the use of thinner (and more esoteric) condoms, knowing that any difference is more of perception than reality.

As is true for most contraceptive methods, older, married couples experienced in using condoms and strongly motivated to avoid another pregnancy are much more effective users than young, unmarried couples with little contraceptive experience. This does not mean that condoms are not useful contraceptives for adolescents, who are likely to have sex unexpectedly or infrequently. Ninety-seven percent of female teenagers who are sexually active report at least occasional condom use.<sup>84</sup>

Prospective users need instructions to avoid pregnancy and STIs. A condom must be placed on the penis before it touches a partner. Uncircumcised men must pull the foreskin back. Prior to unrolling the condom to the base of the penis, air should be squeezed out of the reservoir tip with a thumb and forefinger. The tip of the condom should extend beyond the end of the penis to provide a reservoir to collect the ejaculate (a half-inch of pinched tip). If lubricants are used, they must be water based. Oil-based lubricants (such as Vaseline) will weaken the latex. Couples should be aware that any vaginal medication can compromise condom integrity. After intercourse, the condom should be held at the base as the still-erect penis is withdrawn. Semen must not be allowed to spill or leak. The condom should be handled gently because fingernails and rings can penetrate the latex and cause leakage. If there is evidence of spill or leakage, a spermicidal agent should be quickly inserted into the vagina, and treatment should be initiated within 72 hours—or 120 hours at most—with an emergency contraception method.

## Key Points: Maximal Condom Efficacy

- Use condoms for every act of coitus.
- Place the condom before vaginal contact.
- Create a reservoir at the tip.
- Withdraw while the penis is still erect.
- Hold the base of the condom during withdrawal.

These instructions should be provided to new users of condoms who are likely to be reluctant to ask questions. Most condoms are acquired without medical supervision; therefore, clinicians should use every opportunity to inform patients about their proper use.

Inconsistent use explains most condom failures. Incorrect use accounts for additional failures; also, condoms sometimes break. Breakage rates range from 1 to 8 per 100 episodes of vaginal intercourse (and somewhat higher for anal intercourse), and slippage rates range from 1% to 5%.<sup>83,85</sup> With experienced couples, condom failure due to breakage and slippage (sufficient to increase the risk of pregnancy or STIs) occurs at a rate of about 1%.<sup>86</sup> In a U.S. survey, one pregnancy resulted for every three condom breakages.<sup>87</sup> Concomitant use of spermicides lowers failure rates in case of breakage. In addition, even when there is slippage or breakage, the condom provides some protection against pregnancy and STIs because there is still a reduction in exposure to semen.<sup>88</sup>

Breakage is a greater problem for couples at risk for STIs. An infected man transmits gonorrhea to a susceptible woman approximately two-thirds of the time.<sup>89</sup> If the woman is infected, transmission to the man occurs one-third of the time.<sup>90</sup> The chances of HIV infection after a single sexual exposure ranges from 1 in 1,000 to 1 in 10, which is largely dependent on the HIV viral load.<sup>91,92,93,94</sup>

Condom breakage rates depend on sexual behavior and practices, experience with condom use, the condition of the condoms, and manufacturing quality. Condoms remain in good condition for up to 5 years unless exposed to ultraviolet light, excessive heat or humidity, ozone, or oils. Condom manufacturers regularly check samples of their products to make sure they meet national standards. These procedures limit the proportion of defects to less than 0.1% of all condoms distributed. Contraceptive failure is more likely to be due to nonuse or incorrect use.

**When a condom breaks, or if there is reason to believe spillage or leakage occurred, a woman should contact a clinician preferably within 72 hours and no later than 120 hours. Emergency contraception, as discussed in [Chapter 22](#), should be provided. Couples who rely on condoms for contraception should be educated regarding emergency contraception, and an appropriate method should be kept available for self-medication.**

For the immediate future, prevention of STIs, including the control of HIV, will require a great increase in the use of condoms. We must all be involved in the effort to promote condom use. Condom use must be portrayed in the positive light of STI prevention. An important area of concentration is the teaching of the social skills required to ensure use by a reluctant partner. Using scare tactics about STIs in order to encourage condom use is not sufficient. A more positive approach can yield better compliance. It is useful to emphasize that prevention of STIs will preserve future fertility. **For women not in a stable, monogamous relationship, a dual approach is recommended, combining the contraceptive efficacy and protection against PID**

**offered by estrogen-progestin contraception with the use of a barrier method for prevention of viral STIs.**

# THE FEMALE CONDOM

The female condom is a pouch made of polyurethane, which lines the vagina.<sup>95</sup> An internal ring in the closed end of the pouch covers the cervix and an external ring remains outside the vagina, partially covering the perineum. The female condom is prelubricated with silicone, and a spermicide need not be used. The female condom should be an effective barrier to STI infection. The female condom is impervious in vitro to cytomegalovirus and HIV<sup>96</sup>; however, high cost and acceptability are major problems. The integrity of the female condom is maintained with up to eight multiple uses with washing, drying, and relubricating.<sup>97</sup> The devices are more cumbersome than condoms, and studies have indicated relatively high rates of problems such as slippage.<sup>98</sup> Women who have successfully used barrier methods and who are strongly motivated to avoid STIs are more likely to choose the female condom. With careful use, the efficacy rate should be similar to that of the diaphragm and the cervical cap<sup>99,100,101</sup> (Table 24.3).

**TABLE 24.3 Appropriate Timing of Barrier Contraception Insertion and Removal**

	Diaphragm	Cap	Sponge	Female Condom
Insertion before coitus, no longer than	6 h	6 h	24 h	8 h
After coitus, should be left in place for	6 h	8 h	6 h	6 h
Maximal wear time	24 h	48 h	30 h	8 h

# WITHDRAWAL

---

Withdrawal as a contraceptive method, a method used for centuries and known historically as coitus interruptus, should not be ignored or underrated. The withdrawal method is intuitively learned, has no cost, and efficacy is surprisingly good. If withdrawal before ejaculation occurs with every instance of intercourse, a failure rate over a year of only 4% can be achieved.<sup>5</sup> Clinicians who scoff at this method lose sight of the fact that its typical failure rate of 18.4% during 1 year is very similar to that achieved with male condoms, which are a lowest expected failure rate of 2% and a 17.4% typical rate in 1 year.

A lack of respect for withdrawal as a contraceptive method can be attributed to two factors: an understandable preference for modern methods and the concern that preejaculate fluid contains sperm. Separating preejaculate fluid from the ejaculate in order to study the question has proven difficult and with mixed results. There is one small study of 5 men with a history of premature ejaculation and 3 men with excessive fluid during foreplay.<sup>102</sup> Not a single sperm was detected in preejaculatory fluid specimens collected at the tip of the urethra. In two other studies, no sperm was found in preejaculatory fluid from 16 men, and in 15 men, a few clumps of sperm were present in 5 men.<sup>103,104</sup> Most recently, a study of 27 men and 40 samples showed that 11 men repeatedly produced preejaculate samples with motile sperm in concentrations similar to ejaculate fluid.<sup>105</sup> This could certainly contribute to failures of the withdrawal method.

The modern use of this method (about 3% of contracepting women in the United States<sup>18</sup>) is difficult to accurately measure and is likely underreported because individuals very often combine withdrawal with another method, and the other method is the one reported in family planning surveys.<sup>106</sup> Indeed, many individuals do not classify withdrawal as a contraceptive method, saving that designation for modern methods. Nevertheless, it is not surprising that from 25% to 60% of adolescents report the use of withdrawal.<sup>107,108</sup>

We encourage clinicians to have a greater acceptance for this commonly used method, and it truly is a legitimate contraceptive method as evidenced by the substantial protection against pregnancy that is achievable. Of course, protection against STIs is not to be expected.

# REFERENCES

1. **Himes NE**, Medical History of Contraception, Williams & Wilkins, Baltimore, 1936.
2. **Gamble CJ**, Spermicidal times as aids to the clinician's choice of contraceptive materials, *Fertil Steril* 8:174, 1957.
3. **Trussell J, Vaughan B**, Contraceptive failure, method-related discontinuation and resumption of use: results from the 1995 National Survey of Family Growth, *Fam Plann Perspect* 31:64, 1999.
4. **Fu H, Darroch JE, Haas T, Ranjit N**, Contraceptive failure rates: new estimates from the 1995 National Survey of Family Growth, *Fam Plann Perspect* 31:58, 1999.
5. **Kost K, Singh S, Vaughan B, Trussell J, Bankole A**, Estimates of contraceptive failure from the 2002 National Survey of Family Growth, *Contraception* 77:10, 2008.
6. **Grimes DA, Cates W Jr**, Family planning and sexually transmitted diseases, In: Holmes KK, Mardh P-A, Sparling PF, eds. *Sexually Transmitted Diseases*, 2nd ed, McGraw-Hill, New York, 1990, p. 1087.
7. **Cramer DW, Goldman MB, Schiff I, Belisla S, Albrecht B, Stadel B, Gibson M, Wilson E, Stillman R, Thompson I**, The relationship of tubal infertility to barrier method and oral contraceptive use, *JAMA* 257:2446, 1987.
8. **Rosenberg MJ, Davidson AJ, Chen J-H, Judson FN, Douglas JM**, Barrier contraceptives and sexually transmitted diseases in women: a comparison of female-dependent methods and condoms, *Am J Pub Health* 82:669, 1992.
9. **Rowe PJ**, You win some and you lose some—contraception and infections, *Aust N Z Obstet Gynaecol* 34:299, 1994.
10. **Cates W Jr, Stone K**, Family planning, sexually transmitted diseases and contraceptive choice: a literature update: part I, *Fam Plann Perspect* 24:75, 1992.
11. **Kost K, Forrest JD, Harlap S**, Comparing the health risks and benefits of contraceptive choices, *Fam Plann Perspect* 23:54, 1991.
12. **Feldblum PJ, Kuyoh MA, Bwayo JJ, Omari M, Wong EL, Tweedy KG, Welsh MJ**, Female condom introduction and sexually transmitted infection prevalence: results of a community intervention trial in Kenya, *AIDS* 15:1037, 2001.
13. **French PP, Latka M, Gollub EL, Rogers C, Hoover DR, Stein ZA**, Use-effectiveness of the female versus male condom in preventing sexually transmitted disease in women, *Sex Transm Dis* 30:433, 2003.
14. **Coker AL, Hulka BS, McCann MF, Walton LA**, Barrier methods of contraception and cervical intraepithelial neoplasia, *Contraception* 45:1, 1992.
15. **Schwartz B, Gaventa S, Broome CV, Reingold AL, Hightower AW, Perlman JA, Wolf PH**, Nonmenstrual toxic shock syndrome associated with barrier contraceptives: report of a case-control study, *Rev Infect Dis* 11(Suppl):S43, 1989.
16. **Klonoff-Cohen HS, Savitz DA, Cefalo RC, McCann MF**, An epidemiologic study of contraception and preeclampsia, *JAMA* 262:3143, 1989.
17. **Mills JL, Klebanoff MA, Graubard BI, Carey JC, Berendes HW**, Barrier contraceptive methods and preeclampsia, *JAMA* 265:70, 1991.
18. **Guttmacher Institute**, Contraceptive Use in the United States, Fact Sheet, September 2016.
19. **Cook L, Nanda K, Grimes D**, The diaphragm with and without spermicide for contraception: a Cochrane review, *Hum Reprod* 17:867, 2002.
20. **Fihn SD, Latham RH, Roberts P, Running K, Stamm WE**, Association between diaphragm use and urinary tract infection, *JAMA* 254:240, 1985.
21. **Hooton TM, Scholes D, Hughes JP, Winter C, Roberts PL, Stapleton AE, Stergachis A, Stamm WE**, A prospective study of risk factors for symptomatic urinary tract infection in young women, *New Engl J Med* 335:468, 1996.
22. **Hooton TM, Hillier S, Johnson C, Roberts P, Stamm WE**, Escherichia coli bacteriuria and contraceptive method, *JAMA* 265:64, 1991.

23. **Centers for Disease Control and Prevention**, Toxic shock syndrome, United States, 1970–1982, *MMWR* 31:201, 1982.
24. **Keith L, Berger G, Moss W**, Prevalence of gonorrhea among women using various methods of contraception, *Br J Venereal Dis* 51:307, 1975.
25. **Kelaghan J, Rubin GL, Ory HW, Layde PM**, Barrier method contraceptives and pelvic inflammatory disease, *JAMA* 248:184, 1982.
26. **Padian NS, van der Straten A, Ramjee G, Chipato T, de Bruyn G, Blanchard K, Shiboski S, Montgomery ET, Fancher H, Cheng H, Rosenblum M, van der Laan M, Jewell N, McIntyre J; MIRA Team**, Diaphragm and lubricant gel for prevention of HIV acquisition in southern African women: a randomized controlled trial, *Lancet* 370:251, 2007.
27. **Coffey PS, Kilbourne-Brook M, Brache V, Cochón L**, Comparative acceptability of the SILCS and Ortho ALL-FLEX diaphragms among couples in the Dominican Republic, *Contraception* 78:418, 2008.
28. **Shihata AA**, The FemCap: a new contraceptive choice, *Eur J Contracept Reprod Health Care* 3:160, 1998.
29. **Mauck C, Callahan M, Weiner DH, Dominik R; the FemCap® Investigators Group**, A comparative study of the safety and efficacy of FemCap®, a new vaginal barrier contraceptive, and the Ortho All-Flex® diaphragm, *Contraception* 60:71, 1999.
30. **Bernstein G, Kilzer LH, Coulson AH, Nakamara RM, Smith GC, Bernstein R, Frezieres R, Clark VA, Coan C**, Studies of cervical caps, *Contraception* 26:443, 1982.
31. **Richwald GA, Greenland S, Gerber MM, Potik R, Kersey L, Comas MA**, Effectiveness of the cavity-rim cervical cap: results of a large clinical study, *Obstet Gynecol* 74:143, 1989.
32. **Gollub EL, Sivin I**, The Prentif cervical cap and pap smear results: a critical appraisal, *Contraception* 40:343, 1989.
33. **Hunt WL, Gabbay L, Potts M**, Lea's Shield®, a new barrier contraceptive; preliminary clinical evaluations, three-day tolerance study, *Contraception* 50:551, 1994.
34. **Archer DF, Mauck CK, Viniestra-Sibal A, Anderson FD**, Lea's Shield®: a phase I postcoital study of a new contraceptive barrier device, *Contraception* 52: 167, 1995.
35. **Mauck C, Glover LH, Miller E, Allen S, Archer DF, Blumenthal P, Rosenzweig BA, Dominik R, Sturgen K, Cooper J, Fingerhut F, Peacock L, Gabelnick HL**, Lea's Shield®: a study of the safety and efficacy of a new vaginal barrier contraceptive used with and without spermicide, *Contraception* 53:329, 1996.
36. **Roizen J, Richardson S, Tripp J, Hardwicke H, Lam TQ**, Oves contraceptive cap: short-term acceptability, aspects of use and user satisfaction, *J Fam Plann Reprod Health Care* 28:188, 2002.
37. **Courtot AM, Nikas G, Gravanis A, Psychoyos A**, Effects of cholic acid and "Protectaid" formulations on human sperm motility and ultrastructure, *Hum Reprod* 9:1999, 1994.
38. **Psychoyos A, Creatsas G, Hassan E**, Spermicidal and antiviral properties of cholic acid: contraceptive efficacy of a new vaginal sponge (Protectaid®) containing sodium cholate, *Hum Reprod* 8:866, 1993.
39. **Trussell J, Hatcher RA, Cates W Jr, Stewart FH, Kost K**, Contraceptive failure in the United States: an update, *Stud Fam Plann* 21:51, 1990.
40. **Edelman DA, McIntyre SL, Harper J**, A comparative trial of the Today contraceptive sponge and diaphragm: a preliminary report, *Am J Obstet Gynecol* 150:869, 1984.
41. **Creatsas G, Guerrero E, Guilbert E, Drouin J, Serfaty D, Lemieux L, Suissa S, Colin P**, A multinational evaluation of the efficacy, safety and acceptability of the Protectaid contraceptive sponge, *Eur J Contracept Reprod Health Care* 6:172, 2001.
42. **McIntyre SL, Higgins JE**, Parity and use-effectiveness with the contraceptive sponge, *Am J Obstet Gynecol* 155:796, 1986.
43. **Costello Daly C, Helling-Giese GE, Mati JK, Hunter DJ**, Contraceptive methods and the transmission of HIV: implications for family planning, *Genitourin Med* 70:110, 1994.
44. **Hicks DR, Martin LS, Getchell JP, Health JL, Francis DP, McDougal JS, Curran JW, Voeller B**, Inactivation of HTLV-III/LAV-infected cultures of normal human lymphocytes by nonoxynol-9 in vitro, *Lancet* ii:1422, 1985.
45. **Kreiss J, Ngugi E, Holmes K, Ndinya-Achola J, Waiyaki P, Roberts PL, Ruminjo I, Sajabi R, Kimata**



- J, Fleming TR, Anzala A, Holton D, Plummer F**, Efficacy of nonoxynol-9 contraceptive sponge use in preventing heterosexual acquisition of HIV in Nairobi prostitutes, *JAMA* 268:477, 1992.
46. **Mendez F, Castro A**, Prevention of sexual transmission of AIDS/STD by a spermicide containing benzalkonium chloride, *Arch AIDS Res* 4:115, 1990.
  47. **Zekeng L, Feldblum PJ, Oliver RM, Kaptue L**, Barrier contraceptive use and HIV infection among high risk women in Cameroon, *AIDS* 7:725, 1993.
  48. **Wittkowski KM, Susser E, Kietz K**, The protective effect of condoms and nonoxynol-9 against HIV infection, *Am J Public Health* 88:590, 1998.
  49. **Centers for Disease Control and Prevention**, Nonoxynol-9 spermicide contraception use—United States, 1999, *MMWR* 51:389, 2002.
  50. **Van Damme L, Ramjee G, Alary M, Vuylsteke B, Chandeying V, Rees H, Sirivongrangson P, Mukenge-Tshibaka L, Ettiegne-Traore V, Uaheowitchai C, Karim SS, Masee B, Perriens J, Laga M; for the COL-1492 Study Group**, Effectiveness of COL-1492, a nonoxynol-9 vaginal gel, on HIV-1 transmission in female sex workers: a randomised controlled trial, *Lancet* 360:971, 2002.
  51. **Louv WC, Austin H, Alexander WJ, Stagno S, Cheeks J**, A clinical trial of nonoxynol-9 as a prophylaxis for cervical *Neisseria gonorrhoeae* and *Chlamydia trachomatis* infections, *J Infect Dis* 158:518, 1988.
  52. **Austin H, Louv WC, Alexander WJ**, A case-control study of spermicides and gonorrhea, *JAMA* 251:2822, 1984.
  53. **Niruthisard S, Roddy RE, Chutivongse S**, Use of nonoxynol-9 and reduction in rate of gonococcal and chlamydial cervical infections, *Lancet* 339:1371, 1992.
  54. **Roddy RE, Zekeng L, Ryan KA, Tamoufém U, Weir SS, Wong EL**, A controlled trial of nonoxynol 9 film to reduce male-to-female transmission of sexually transmitted diseases, *New Engl J Med* 339:504, 1998.
  55. **Roddy RE, Zekeng L, Ryan KA, Tamoufe U, Tweedy KG**, Effect of nonoxynol-9 gel on urogenital gonorrhea and chlamydial infection: a randomized controlled trial, *JAMA* 287:1117, 2002.
  56. **Richardson BA, Lavreys L, Martin HL Jr, Stevens CE, Ngugi E, Mandaliya K, Bwayo J, Ndinya-Achola J, Kreiss JK**, Evaluation of a low-dose nonoxynol-9 gel for the prevention of sexually transmitted diseases: a randomized clinical trial, *Sex Transm Dis* 28:394, 2001.
  57. **Barbone F, Austin H, Louv WC, Alexander WJ**, A follow-up study of methods of contraception, sexual activity, and rates of trichomoniasis, candidiasis, and bacterial vaginosis, *Am J Obstet Gynecol* 163:510, 1990.
  58. **Raymond E, Dominik R; The Spermicide Trial Group**, Contraceptive effectiveness of two spermicides: a randomized trial, *Obstet Gynecol* 93:896, 1999.
  59. **Raymond EG, Chen PL, Luoto J; for the Spermicide Trial Group**, Contraceptive effectiveness and safety of five nonoxynol-9 spermicides: a randomized trial, *Obstet Gynecol* 103:430, 2004.
  60. **Louik C, Mitchell AA, Werler MM, Hanson JW, Shapiro S**, Maternal exposure to spermicides in relation to certain birth defects, *New Engl J Med* 317:474, 1987.
  61. **Bracken MB, Vita K**, Frequency of non-hormonal contraception around conception and association with congenital malformations in offspring, *Am J Epidemiol* 117:281, 1983.
  62. **Einarson TR, Koren G, Mattice D, Schechter-Tsafiri O**, Maternal spermicide use and adverse reproductive outcome: a meta-analysis, *Am J Obstet Gynecol* 162:655, 1990.
  63. **Malyk B**, Preliminary results: serum chemistry values before and after the intravaginal administration of 5% nonoxynol-9 cream, *Fertil Steril* 35:647, 1981.
  64. **Niruthisard S, Roddy RE, Chutivongse S**, The effects of frequent nonoxynol-9 use on vaginal and cervical mucosa, *Sex Transm Dis* 268:521, 1991.
  65. **Roddy RE, Cordero M, Cordero C, Fortney JA**, A dosing study of nonoxynol-9 and genital irritation, *AIDS* 4:165, 1993.
  66. **Hooton TM, Fennell CL, Clark AM, Stamm WE**, Nonoxynol-9: differential antibacterial activity and enhancement of bacterial adherence to vaginal epithelial cells, *J Infect Dis* 164:1216, 1991.
  67. **Skoler-Karpoff S, Ramjee G, Ahmed K, Altini L, Plagianos MG, Friedland B, Govender S, De Kock A, Cassim N, Palanee T, Dozier G, Maguire R, Lahteenmaki P**, Efficacy of Carraguard for prevention of HIV infection in women in South Africa: a randomised, double-blind, placebo-controlled trial, *Lancet* 372:1977,

2008.

68. **Ballagh SA, Brache V, Mauck C, Callahan MM, Cochon L, Wheelless A, Moench TR, A Phase I study of the functional performance, safety and acceptability of the BufferGel® Duet™**, *Contraception* 77:130, 2008.
69. **Mayer KH, Abdool Karim SS, Kelly C, Maslankowski L, Rees H, Profy AT, et al.**, Safety and tolerability of vaginal PRO 2000 gel in sexually active HIV-uninfected and abstinent HIV-infected women, *AIDS* 17:321, 2003.
70. **Abdool Karim SS, Richardson BA, Ramjee G, Hoffman IF, Chirenje ZM, et al.**, Safety and effectiveness of BufferGel and 0.5%PRO2000 Gel for the prevention of HIV infection in women, *AIDS* 25:957, 2011.
71. **Williams DL, Newman DR, Ballagh SA, Creinin MD, Barnhart K, Weiner DH, Bell AJ, Jamieson DJ**, Phase I safety trial of two vaginal microbicide gels (Acidform or BufferGel) used with a diaphragm compared to KY jelly used with a diaphragm, *Sex Transm Dis* 34:977, 2007.
72. **Stone KM, Grimes DA, Magder LS**, Primary prevention of sexually transmitted diseases. A primer for clinicians, *JAMA* 255:1763, 1986.
73. **Van de Perre P, Jacobs D, Sprecher-Goldberger S**, The latex condom, an efficient barrier against sexual transmission of AIDS-related viruses, *AIDS* 1:49, 1987.
74. **Winer RL, Hughes JP, Feng Q, O'Reilly S, Kiviat NB, Holmes KK, Koutsky LA**, Condom use and the risk of genital human papillomavirus infection in young women, *New Engl J Med* 354:2645, 2006.
75. **Fihn SD, Boyko EJ, Normand EH, Chen C-L, Grafton JR, Hunt M, Yarbrow P, Scholes D, Stergachis A**, Association between use of spermicide-coated condoms and Escherichia coli urinary tract infection in young women, *Am J Epidemiol* 144:512, 1996.
76. **DeVincenzi I**; for the **European Study Group on Heterosexual Transmission of HIV**, A longitudinal study of human immunodeficiency virus transmission by heterosexual partners, *New Engl J Med* 331:341, 1994.
77. **Davis KR, Weller SC**, The effectiveness of condoms in reducing heterosexual transmission of HIV, *Fam Plann Perspect* 31:272, 1999.
78. **Diaz T, Schable B, Chu SY**; the **Supplement to HIV and AIDS Surveillance Project Group**, Relationship between use of condoms and other forms of contraception among human immunodeficiency virus-infected women, *Obstet Gynecol* 86:277, 1995.
79. **Wald A, Langenberg AG, Link K, Izu AE, Ashley R, Warren T, Tyring S, Douglas JM Jr, Corey L**, Effect of condoms on reducing the transmission of herpes simplex virus type 2 from men to women, *JAMA* 285:3100, 2001.
80. **Freziers RG, Walsh TL, Nelson AL, Clark VA, Coulson AH**, Breakage and acceptability of a polyurethane condom: a randomized, controlled study, *Fam Plann Perspect* 30:73, 1998.
81. **Steiner MJ, Dominik R, Rountree RW, Nanda K, Dorflinger L**, Contraceptive effectiveness of a polyurethane condom and a latex condom: a randomized controlled trial, *Obstet Gynecol* 101:539, 2003.
82. **Grady WR, Klepinger DH, Billy JOG, Tanfer K**, Condom characteristics: the perceptions and preferences of men in the United States, *Fam Plann Perspect* 25:67, 1993.
83. **Trussell J, Warner DL, Hatcher RA**, Condom slippage and breakage rates, *Fam Plann Perspect* 24:20, 1992.
84. **Martinez GM, Abma JC**, Sexual activity, contraceptive use, and childbearing of teenagers aged 15–19 in the United States, *NCHS Data Brief* 209, July 2015.
85. **Sparrow MJ, Lavill K**, Breakage and slippage of condoms in family planning clients, *Contraception* 50:117, 1994.
86. **Rosenberg MJ, Waugh MS**, Latex condom breakage and slippage in a controlled clinical trial, *Contraception* 56:17, 1997.
87. **Population Information Program**, *Population Reports, Condoms, Now More than Ever*, The Johns Hopkins University, Baltimore, Report No. H-81, 1990.
88. **Walsh TL, Freziers RG, Peacock K, Nelson AL, Clark VA, Bernstein L, Wraaxall BGD**, Use of prostate-specific antigen (PSA) to measure semen exposure resulting from male condom failures: implications

- for contraceptive efficacy and the prevention of sexually transmitted disease, *Contraception* 67: 139, 2003.
89. **Platt R, Rice PA, McCormack WM**, Risk of acquiring gonorrhea and prevalence of abnormal adnexal findings among women recently exposed to gonorrhea, *JAMA* 250:3205, 1983.
  90. **Hooper RR, Reynolds GM, Jones OG, Zaidi A, Wiesner RJ, Latimer KP, Lester A, Campbell AF, Harrison WO, Karney WW, Holmes KK**, Cohort study of venereal disease. I. The risk of gonorrhea transmission from infected women to men, *Am J Epidemiol* 108:136, 1978.
  91. **Donnell, D, Baeten JM, Kiarie J, Thomas KK, Stevens W**, et al., Heterosexual HIV-1 transmission after initiation of antiretroviral therapy: a prospective cohort analysis, *Lancet* 375:2092, 2010.
  92. **Quinn TC, Wawer MJ, Sewankambo N, Serwadda D, Li C, Wabwire-Mangen F, Meehan MO, Lutalo T, Gray RH**, Viral load and heterosexual transmission of human immunodeficiency virus type 1, *N Engl J Med* 342:921, 2000.
  93. **Anderson RM, Medley GF**, Epidemiology of HIV infection and AIDS: incubation and infectious periods, survival and vertical transmissions, *AIDS* 2 (Suppl 1):557, 1988.
  94. **Cameron DW, Simonsen JN, D'Costa LJ, Ronald AR, Maitha GM, Gakinya MN, Cheang M**, et al., Female to male transmission of human immunodeficiency virus type 1: risk factors for seroconversion in men, *Lancet* ii:403, 1989.
  95. **Soper DE, Brockwell NJ, Dalton JP**, Evaluation of the effects of a female condom on the female lower genital tract, *Contraception* 44:21, 1991.
  96. **Drew WL, Blair M, Miner RC, Conant M**, Evaluation of the virus permeability of a new condom for women, *Sex Transm Dis* 17:110, 1990.
  97. **Beksinska M, Rees HV, Dickson-Tetteh KE, Mqoqi N, Kleinschmidt I, McIntyre JA**, Structural integrity of the female condom after multiple uses, washing, drying, and re-lubrication, *Contraception* 63:33, 2001.
  98. **Bounds W, Guillebaud J, Newman GB**, Female condom (Femidom). A clinical study of its use-effectiveness and patient acceptability, *Br J Fam Plann* 18:36, 1992.
  99. **Trussell J, Sturgen K, Strickler J, Dominik R**, Comparative contraceptive efficacy of the female condom and other barrier methods, *Fam Plann Perspect* 26:66, 1994.
  100. **Farr G, Gabelnick H, Sturgen K, Dorflinger L**, Contraceptive efficacy and acceptability of the female condom, *Am J Public Health* 84:1960, 1994.
  101. **Trussell J**, Contraceptive efficacy of the Reality® female condom, *Contraception* 58:147, 1998.
  102. **Zukerman Z, Weiss DB, Orvieto R**, Does preejaculatory penile secretion originating from Cowper's gland contain sperm?, *J Assist Reprod Genet* 20:157, 2003.
  103. **Iaria G, Jacobs JL, Polsky B, Koll B, Baron P, MacLow C, Armstrong DK, Schlegel PN**, Detection of HIV-1 DNA sequences in pre-ejaculatory fluid, *Lancet* 340:1469, 1992.
  104. **Pudney J, Oneta M, Mayer K, Seage 3rd G, Anderson D**, Pre-ejaculatory fluid as potential vector for sexual transmission of HIV-1, *Lancet* 340:1470, 1992.
  105. **Killick, SR, Leary C, Trussell J, Guthrie KA**, Sperm content of pre-ejaculatory fluid, *Hum Fertil* 14:48, 2011.
  106. **Jones RK, Fennell J, Higgins JA, Blanchard K**, Better than nothing or savvy risk-reduction practice? The importance of withdrawal, *Contraception* 79:407, 2009.
  107. **Sznitman SR, Romer D, Brown LK, DiClemente RJ, Valois RF, Vanable PA, Carey MP, Stanton B**, Prevalence, correlates, and sexually transmitted infection risk related to coitus interruptus among African-American adolescents, *Sex Transm Dis* 36:218, 2009.
  108. **Woods JL, Hensel DJ, Fortenberry JD**, Contraceptive withdrawal in adolescents: a complex picture of usage, *J Pediatr Adolesc Gynecol* 22:233, 2009.

# INFERTILITY

---



**Chapter 25:** Female Infertility



**Chapter 26:** Male Infertility



**Chapter 27:** Induction of Ovulation



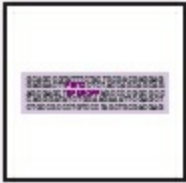
**Chapter 28:** Assisted Reproductive Technologies



**Chapter 29:** Fertility Preservation



**Chapter 30:** Recurrent Early Pregnancy Loss



## **Chapter 31: Genetics**



## **Chapter 32: Endometriosis**



## **Chapter 33: Ectopic Pregnancy**

# Female Infertility

Infertility is defined as 1 year of regular unprotected intercourse without conception.<sup>1</sup> The term **subfertility** is used interchangeably to describe women or couples who may not be sterile but exhibit decreased reproductive efficiency. Approximately 85–90% of healthy young couples conceive within 1 year, most within 6 months.<sup>2,3</sup> Infertility therefore affects approximately 10–15% of couples and represents an important part of clinical practice.<sup>4</sup> Cycle **fecundability** is the probability that a cycle will result in pregnancy and **fecundity** is the probability that a cycle will result in a live birth.

Contrary to popular perception, the overall incidence of infertility does not seem to have increased over the past three decades.<sup>5</sup> However, the evaluation and treatment of infertility have changed dramatically during the same period. Three major developments have had the greatest impact. First was the introduction of in vitro fertilization (IVF) and other assisted reproductive technologies (ART). ART techniques have provided the means to study reproductive processes in new and more revealing ways and have markedly improved the prognosis for a great many infertile couples, particularly those whose infertility relates to severe tubal damage or male factors. Second, changes in population demographics have resulted in greater numbers of women attempting pregnancy at older ages when they are inherently less biologically fertile. Third, advances in ART and concerns about the age-related decline in fertility have combined to attract greater media attention and to raise public awareness of infertility and modern treatments. Consequently, infertile couples are now more likely to seek medical advice, evaluation, and treatment.

# THE EPIDEMIOLOGY OF INFERTILITY IN THE UNITED STATES

---

The first U.S. Census was in 1790. At that time, the crude birth rate was 55 per 1,000 total population; in 2015, it was 12.4 per 1,000,<sup>6</sup> representing a record low for the nation with nearly a 77% decline over the past 200-plus years and a 16% decline since 1990 (16.7 per 1,000 population). The general fertility rate (births per 1,000 women aged 15–44) in 2015 was 62.5, 8% lower than in 1990 (70.9/1,000), 25% lower than in 1970 (87.9/1,000), and 41% lower than in 1950 (106.2/1,000) during the postwar “baby boom.”<sup>6,7,8</sup>

**The overall long-term decline in the US birth and fertility rates has been attributed to several factors:**

- **Greater interest in advanced education and careers among women**
- **Later marriage and more frequent divorce**
- **Improvements in contraception and access to family planning services**
- **Delayed childbearing**
- **Decreased family size**

Attitudes toward women and among women in our society have changed dramatically in many ways over the past 50 years. Expanding opportunities have increased interests in advanced education and careers among women. The U.S. Census data indicate that in 1970, only 8.2% of women aged 25 and older had completed 4 or more years of college; by 2015, that proportion had quadrupled and reached the same rate as men (33%).<sup>9</sup> Women have represented the majority of college students in the United States since 1979. In recent years, the majority of bachelor’s and more advanced degrees have been awarded to women. The proportion of US women with infant children in the workforce has steadily increased, from 31% in 1976 to 59% in 2016.<sup>9</sup> In 2016, 82% of all women aged 25–44 years were in the labor force.<sup>10</sup>

Greater focus on education and careers among women triggered other trends in modern society. Less frequent and later marriage and more frequent divorce were among the most striking. First-marriage rates in the United States peaked after World War II, between 1945 and 1947 (143 per 1,000 single women aged 15–44), and declined about 15% every 10 years and approximately 50% overall over the next five decades.<sup>11</sup> The median age at first marriage for women has risen steadily since 1960 (20.3 years) and reached an all-time high in 2009 (26.5 years). The proportion of never-married women aged 25–29 has also steadily increased from 26.9% in 1986 to 46.8%

in 2009.<sup>12</sup> The probability of future marriage for women decreases as age increases: 84% at age 25, 72% at age 30, 52% at age 35, and 41% at age 40.<sup>13</sup> If and when women do marry, they also are more likely to divorce than in the past.<sup>11,13,14,15</sup> Divorce rates among women of reproductive age rose quickly after 1960 to more than double by 1980 (40 per 1,000 married women aged 15–44) and have declined only slightly over the last 30 years. The National Center for Health Statistics estimates that approximately one-third of new marriages among younger people will end in divorce within 10 years and 43% within 15 years. Once-married women also are increasingly less likely to remarry. Remarriage rates peaked in 1968 (166 per 1,000 divorces or widowed women aged 15–44) as divorce rates began to rise, but have since declined steadily by more than one-third, in parallel with first-marriage rates.<sup>11,13,14,15</sup>

The postwar “baby boom” generation, those born between 1946 and 1964, was the first to be afforded the means to safely and effectively control their fertility. Expanding contraceptive options and access to family planning and legalized abortion services over the past 5 decades definitely have contributed to declining US birth and fertility rates. Their effects have been direct, by reducing the number of unplanned pregnancies and births, and indirect, by helping women to avoid pregnancy until their education and career goals were met, and marriage and family become a priority.

The net result of all of these societal changes was a trend to delayed childbearing among American women. The mean age at first live birth has risen steadily, from 21.4 years in 1970 to an all-time high 26.4 years in 2015 (5 years and 24% higher). The percentage of first births occurring to women aged 30 or older increased drastically between 1970 and 2014.<sup>6,16</sup> The figure is increased by 26% between 2000 and 2014.

Between 1970 and 2015, birth rates fell for women aged 15–19 (68.3 vs. 22.3/1,000), 20–24 (167.8 vs. 76.8/1,000), and 25–29 (145.1 vs. 104.3/1,000) and increased for women aged 30–34 (73.3 vs. 101.5/1,000), 35–39 (31.7 vs. 51.8/1,000), and 40–44 (8.1 vs. 11.0/1,000).<sup>6,8</sup> Predictably, increasing age at first birth and declining fertility rates combined to result in fewer births per woman. At the height of the postwar baby boom, the US total fertility rate (births by age 45) reached a modern high of 3.7 births per woman (1957). Thereafter, the total fertility rate declined to a low of 1.8 in 1976 and has remained stable with some fluctuations.<sup>6</sup> In 2015, the total fertility rate was 1.8, under the population replacement rate, as has generally been since 1971. Likewise, the total fertility rates in most industrialized countries are inadequate even to ensure replacement of the population.<sup>17</sup>

Trends in the incidence of infertility among US women have been difficult to define confidently, partly due to confusion over the use of two different measures—impaired fecundity and infertility, which are defined differently, describe different populations,



and can yield conflicting data.<sup>18,19</sup> However, evidence indicates that the incidence of infertility in the United States now is declining.<sup>20</sup> The earliest national estimate of infertility, from the 1965 National Survey of Family Growth (NSFG), was 11.2%. In 1982, 8.5% of married American women were infertile, and in 2002, 7.4% were infertile, representing a 10% decrease over the intervening 20 years.<sup>20</sup> The latest figure from 2015 is 6.7%, demonstrating further decline.<sup>21</sup> A similar trend is observed worldwide. An analysis of 277 demographic and reproductive health surveys from 173 countries showed statistically similar prevalence of infertility in 1990 and 2010, while reduced child-seeking behavior resulted in a decrease in primary (1.6% to 1–0.5%) and secondary (3.9% to –3.0%) infertility, leading to unchanged overall prevalence due to increasing population.<sup>22</sup>

The array of infertility services, and their availability, has increased dramatically over the last 25 years. The public has a greater awareness of infertility and modern treatments, largely due to the increased media attention, good and bad, surrounding the advances and controversies relating to ART. As infertility has become more visible, and more socially acceptable, couples have become more comfortable to seek evaluation and treatment.

According to data derived from the NSFG conducted in 1995, 9.3 million women aged 15–44 (15%) had ever received infertility services, an increase from 6.6 million women (12%) in 1982.<sup>23</sup> These data indicated that the demand for infertility services increased during the 1980s and early 1990s, corresponding to the aging of baby boomers and the time when the availability of ART was rapidly expanding. Compared to the general population, women seeking infertility services were more likely to be older (aged 35–44 years; 43% vs. 36%), nulliparous (36% vs. 16%), married (79% vs. 64%), and relatively affluent (61% vs. 51%) and to have health care insurance (83% vs. 74%).<sup>23</sup> Among those who received infertility services, 35% had used ovulation-inducing drugs and 1.6% had undergone some form of ART. In the 2002 NSFG, 7.3 million women aged 15–44 reported ever having used infertility services, representing a significant decrease of approximately 20% since 1995.<sup>24</sup> The figure has remained unchanged in 2006–2010 and 2011–2015 at 7.4 and 7.3 million, respectively, representing 12% of women in this age bracket. Advice (38%), testing (36%), and medical help to prevent miscarriage (34%) were the most common types of services received. Thirty-two percent reported receiving drugs to improve ovulation and 19% intrauterine insemination (IUI).<sup>25</sup>

# AGING AND FERTILITY

---

The effects of aging on female fertility are perhaps best revealed by the results of studies in “natural” populations wherein couples reproduce without voluntary restrictions<sup>26</sup>; the Hutterites in North America are a classic example. Contraception is condemned in the sect, which emigrated originally from Switzerland in the 16th century and settled ultimately in communal colonies in South Dakota in the late 19th century. Studies of fertility in the Hutterites illustrate how fertility declines with advancing age.<sup>27</sup> Whereas only 2.4% of Hutterite women were infertile, 11% bore no children after age 34, 33% were infertile by age 40, and 87% were infertile at age 45. **Although revealing, these and other data derived from studies in natural populations may not reflect true biologic reproductive potential, for several reasons:**

- **Women who have children when young may be less inclined to conceive again in later life.**
- **Coital frequency often declines as age increases, reflecting decreasing desire or lack of a partner.**
- **The incidence of subclinical abortion is unknown.**
- **The cumulative impact of other diseases or conditions that can adversely affect fertility (e.g., pelvic infections, leiomyomata, endometriosis) is greater in older women.**

Taken together, data from studies in the Hutterites and other natural populations suggest that fertility in women peaks between the ages of 20 and 24, decreases relatively little until approximately age 30–32, and then declines progressively. **Overall, fertility rates are 4–8% lower in women aged 25–29 years, 15–19% lower in those aged 30–34, 26–46% lower in women aged 35–39, and as much as 95% lower for women aged 40–45 years.**<sup>28,29</sup>

Variations in fertility rates among natural populations could reflect differences in genetic factors or socioeconomic conditions at different times and in different places.

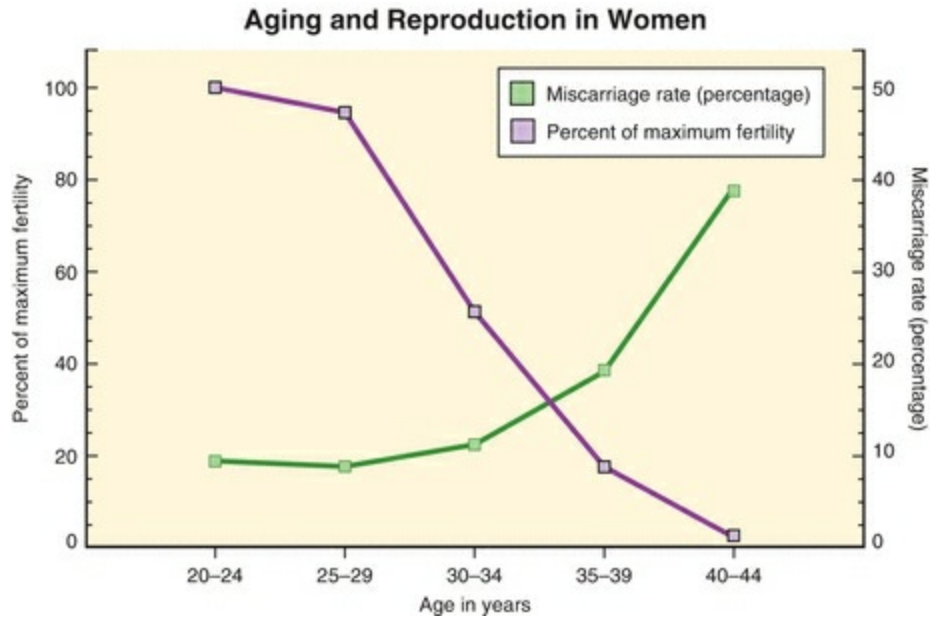
Other evidence for the adverse effect of aging on fertility derives from numerous studies of cumulative conception rates among women attempting pregnancy by artificial insemination with donor sperm. Since women in donor insemination programs are less likely to have other infertility factors and carefully timed inseminations eliminate the confounding effects of decreasing coital frequency with increasing age, donor insemination studies provide good estimates of female fertility. In a French study involving more than 2,000 women across up to 12 insemination cycles, conception rates were highest in those aged 25 or younger (73%) and aged 26–30 (74%), 16% lower

(62%) in women aged 31–35, and 27% lower in those over age 35 (54%).<sup>30</sup> An American donor insemination study yielded similar results, observing lower overall conception rates and a twofold higher number of inseminations per conception in women over age 35.<sup>31</sup> A Dutch study observed that the probability of a healthy live birth decreased by approximately 3.5% per year after age 30.<sup>29</sup> In a large British study of nearly 3,000 donor insemination cycles from a single center, cumulative conception rates in women over age 30 were 20–35% lower than in younger women after 3 (17% vs. 21%), 6 (26% vs. 40%), and 12 insemination cycles (44% vs. 62%).<sup>32</sup>

Success rates achieved with ART using nondonor eggs also decline as age increases. The numbers of oocytes retrieved and embryos available and implantation, pregnancy, and live birth rates are lower in older than in younger women.<sup>33</sup> Annual reports derived from registry data collected by the Centers for Disease Control and Prevention (CDC) in the United States since 1989 demonstrate consistently that age is the single most important factor affecting the probability of success with ART. Pregnancy and live birth rates for ART cycles using fresh, nondonor eggs or embryos vary little for women under age 32, but thereafter decrease steadily in an almost linear fashion as age increases. Regardless whether success rates are calculated per cycle, per oocyte retrieval, or per embryo transfer, the result is the same. In the 2015 US national summary, the live birth rate per embryo transfer was 46.5% for women under age 35, 38.4% for ages 35–37, 27.4% for ages 38–40, 15.5% for ages 41–42, and 6.6% for women aged 43–44 years, despite higher number of embryos being transferred to older women.<sup>33</sup>

The age-related decline in ART live birth rates reflects not only decreasing fertility but also increasing pregnancy wastage. Just as fertility decreases with increasing age, the incidence of clinically recognized miscarriage rises as age advances. **Miscarriage rates in natural conception cycles are generally low before age 30 (7–15%) and rise with age, only slightly for ages 30–34 (8–21%), but to a greater extent for ages 35–39 (17–28%) and ages 40 and older (34–52%).**<sup>28,34,35,36</sup> The same pattern is observed in pregnancies resulting from ART. In the 2015 US national summary of IVF outcomes, miscarriage rates were below 15% for women under age 35, almost 29% at age 40, and 65% for women aged 44 and older.<sup>33</sup> Longitudinal studies of healthy young women wherein daily urine samples were monitored for the appearance of human chorionic gonadotropin (hCG) have revealed that true spontaneous miscarriage rates (also including clinically unrecognized “biochemical” pregnancies) are substantially higher.<sup>37,38,39</sup> Up to 60% of all conceptions miscarry within the first 12 weeks of gestation and 20–40% of all early pregnancy losses go unrecognized. Whether the incidence of occult early pregnancy loss also is higher in older women than young women has not been determined. If so, the relationship between true spontaneous

miscarriage rates and age may be even more dramatic. Even if not, the overall miscarriage risk (recognized and unrecognized) in women over age 40 approaches or exceeds 75% (Figure 25.1).<sup>38,40</sup>



**FIGURE 25.1**

# Physiology of Reproductive Aging

The age-related decrease in female fertility and the societal trends toward delayed childbearing have focused a great deal of attention on the physiology of reproductive aging. Consequently, our understanding of the mechanisms that govern the pace of follicular depletion, the endocrinology of reproductive aging, the age-related changes in follicular dynamics and oocyte quality, and the genetic determinants of ovarian aging has advanced greatly over the past 30 years. We long ago recognized the changes in menstrual cycle characteristics that accompany advancing age, but now much better understand the mechanisms responsible for those changes. We long ago recognized that fertility declines as age increases, but now have measures of reproductive aging that help to guide our efforts to overcome its limitations. We may not be able to prevent aging, but now we can better help women to set and to realize their reproductive goals.

## Follicular Depletion

In humans, the number of oocytes peaks around the 20th week of gestation when approximately 6–7 million oocytes arrested at the first meiotic prophase are found in the ovarian cortex.<sup>41,42,43</sup> Afterward, regulated apoptosis starts an irreversible decline in the germ cell population.<sup>44</sup> The number of oocytes declines to 1–2 million at birth<sup>45</sup> and to 300,000–400,000 by puberty.<sup>42,46</sup> Over the next 35–40 years of reproductive life, only about 400 oocytes will ovulate, the rest being lost through atresia. By age 40, the number of follicles shrinks to approximately 25,000, and at menopause, there remains less than 1,000 follicles.<sup>47,48,49,50</sup>

Accurate modeling of the pattern of follicle depletion in the human ovary is important because the ability to measure reproductive aging or to predict the number of remaining follicles—to tell time on the biologic clock—would help women make informed decisions about their reproductive plans.<sup>51</sup> However, for obvious reasons, accurate measures of the numbers of primordial follicles across a human female reproductive life span are difficult to obtain.

The first attempt to define the age-related pattern of follicular depletion was based on an analysis of combined data from older morphometric studies and yielded a biexponential model of ovarian aging, describing a biphasic pattern of oocyte depletion, with a distinct increase in the rate of decline beginning at approximately age 37.5 years.<sup>41,47,52,53</sup> The biphasic model was widely accepted, despite the biologic implausibility of an abrupt, population-wide, physiologic shift in the rate of follicular depletion.<sup>54,55</sup> The model still is cited frequently,<sup>56,57</sup> but subsequent work has demonstrated that a simpler, more biologically plausible, exponential<sup>48,58</sup> or power

function<sup>59</sup> conforms best with available human data and current concepts regarding the mechanisms that govern the rate of follicular depletion.<sup>51,60</sup> **The current working model describes a gradually increasing rate of follicular depletion in which the pace of decline increases as the number of follicles remaining decreases, supported by evidence that paracrine factors secreted by primordial follicles inhibit recruitment and regulate the size of the resting follicular pool.**<sup>51,60,61,62</sup> The model describes the mean trajectory of follicular depletion, but a great deal of population variation remains unexplained. Some of the variation among individuals doubtless relates to differences in the size of the initial follicular pool, which could be random but likely is genetically determined, and on lifestyle factors. The current model of reproductive aging still is evolving and does not yet have any real clinical utility because it cannot predict the reproductive life span for an individual woman.<sup>51,59</sup>

## **Endocrinology of Reproductive Aging**

Toward the end of the reproductive period, serum follicle-stimulating hormone (FSH) levels begin to rise, while luteinizing hormone (LH) concentrations remain unchanged. This occurs before any discernible change in menstrual regularity. The subtle “monotropic” rise in circulating FSH concentrations is most apparent during the intercycle transition, when the corpus luteum regresses and menses begins, and could result from age-related changes in the pattern of pulsatile kisspeptin and gonadotropin-releasing hormone (GnRH) secretion or from progressive follicular depletion and decreased inhibitory feedback by ovarian hormones. The weight of available evidence supports the second explanation.<sup>63,64</sup>

A variety of studies in animals and women have identified changes in the patterns of hypothalamo-pituitary hormone secretion across the menopausal transition. In rodents, an age-related decrease in pulsatile GnRH and LH secretion and a loss of positive estrogen feedback have been observed, before the follicular pool is exhausted.<sup>65,66,67,68</sup> In nonhuman primates, pulsatile GnRH release increases during the perimenopause and the positive feedback response remains intact.<sup>69</sup> Studies in perimenopausal and postmenopausal women have yielded conflicting results. Whereas some have observed changes in sensitivity to estrogen feedback signals<sup>70,71</sup> or in LH pulse amplitude or frequency,<sup>72,73,74,75,76,77</sup> others have not.<sup>78,79,80</sup> The response to exogenous GnRH stimulation also is inconsistent.<sup>76,81,82</sup> On balance, these data suggest strongly that age-related changes in pulsatile LH secretion and gonadotropin concentrations merely reflect changes in ovarian feedback signals and do not result from aging of the hypothalamo-pituitary axis.

**The bulk of available evidence indicates that the progressive increase in FSH**

**concentrations associated with reproductive aging results from a progressive decrease in the levels of feedback inhibition from the smaller cohorts of follicles recruited from a shrinking follicular pool.** Circulating follicular phase inhibin B levels (derived primarily from smaller antral follicles) decrease as or even before FSH concentrations begin to increase.<sup>63,83,84,85,86,87,88,89,90</sup> Inhibin A levels also decline, but only in the later stages of reproductive aging, after the onset of menstrual irregularity.<sup>87,91,92,93,94</sup> Both inhibins selectively inhibit pituitary FSH secretion. Consequently, FSH levels rise progressively as inhibin production from smaller cohorts of aging follicles decreases, most noticeably in the early follicular phase. Whereas declining inhibin production also could reflect a decrease in the functional capacity of older follicles,<sup>95</sup> the observation that preovulatory follicular fluid inhibin concentrations are similar in young and older cycling women suggests that the number of remaining follicles is more important.<sup>83</sup> Ovarian steroid hormones do not play a major role. The initial rise in FSH levels precedes any measurable decrease in estradiol levels, by several years.<sup>64,96</sup> Follicular phase estradiol levels in older cycling women generally are similar to those in younger women and often even higher.<sup>83,97</sup> Luteal phase estrogen and progesterone levels also do not seem to change consistently with advancing age.<sup>63,85,87,98,99,100,101</sup> Moreover, in sporadic ovulatory cycles in aging women, serum concentrations of estradiol and progesterone are comparable to those observed in younger women.<sup>102</sup>

As age and FSH levels increase, the follicular phase becomes shorter<sup>103,104,105</sup>; LH levels and luteal phase duration remain unchanged. As the follicular phase shortens, estradiol levels rise earlier, suggesting that higher FSH levels stimulate more rapid follicular development.<sup>63</sup> **However, careful studies have shown that the earlier rise in estradiol levels results not from accelerated follicle growth, but from advanced follicular development at the beginning of the cycle and earlier selection of the dominant follicle.**<sup>98,104,106</sup> The earlier increase in follicular phase FSH level also frequently results in more than one dominant follicle,<sup>107,108,109</sup> explaining the higher prevalence of dizygotic twinning in older cycling women.<sup>98,107,110</sup>

Reproductive aging already is quite advanced when the first clinical sign appears. Cycles remain regular, but overall cycle length and variability decrease gradually, reaching a nadir at an average age of 42 years,<sup>103,111</sup> when fertility is at or near an end. However, women generally take notice only when cycles become irregular, marking the beginning of the menopausal transition.<sup>112</sup> The menopausal transition begins at an average age of 46 years, but can arrive as early as age 34 and as late as age 54 years.<sup>103,111,113,114,115</sup> Thereafter, average cycle length and variability increase steadily as ovulations become less regular and frequent.<sup>111</sup> Regardless of age, the interval from

loss of menstrual regularity to menopause is relatively fixed, spanning approximately 5–6 years.<sup>46,113,116</sup> The age of menopause, recognized only in retrospect, averages 51 years, but ranges widely between ages 40 and 60 years.<sup>115,117,118,119,120,121,122</sup> The variation in menopausal age is very similar across populations and generally follows a normal distribution that is slightly skewed to younger ages.<sup>122,123,124</sup>

## Genetics of Reproductive Aging

Barring any disease that destroys or causes the removal of ovarian tissue and any important environmental insults, the total number of follicles at birth, and the age when the supply is exhausted, is genetically determined.<sup>46,122,125,126,127,128,129,130,131,132</sup>

There is good correlation between menopausal age in mothers and daughters and between sisters, suggesting that genetic factors play an important role in determining menopausal age.<sup>133,134,135</sup> **Approximately 10% of women become menopausal by the age of 45,<sup>115,122</sup> probably because they were endowed with a smaller than average ovarian follicular pool that is functionally depleted at an earlier age.** Pedigree analysis has revealed that the genetic features of early menopause (age 40–45) and premature ovarian failure (POF) are similar, suggesting a dominant pattern of inheritance through maternal or paternal relatives.<sup>136,137</sup> The same genetic factors that determine the age at menopause also likely determine the age of reproductive milestones preceding the menopause.<sup>138</sup> In natural populations, the age at the last birth varies as widely as the age at menopause, but occurs on average 10 years earlier.<sup>46</sup> Moreover, women who repeatedly respond poorly to exogenous gonadotropin stimulation also tend to have an earlier menopausal transition,<sup>138,139,140,141</sup> suggesting their poor response reflects an advanced stage of follicular depletion, beginning years sooner than would be anticipated normally.<sup>138</sup>

Genes affecting reproductive hormones (FSH, FSHR, LH, LHR, CYP17, CYP19) or involved in the initial growth of follicles (GDF9, BMP15, GPR3) impact follicular function; mutations are rare in humans, but polymorphisms could influence the rate of follicular recruitment and depletion and thereby affect the length of reproductive life.<sup>142</sup> Variations in other genes encoding DNA-binding proteins and transcription factors (NOBOX, LHX8) and RNA-binding proteins (EPAB, CPEB, NANOS) expressed during oogenesis could affect germ cell formation; mutations causing POF have been identified in a few women.<sup>143,144,145</sup> Variations in other genes with links to POF also might affect the rate of follicular depletion in normal women (ADAMTs9, FOXL2).<sup>146,147</sup> In a Dutch cohort study, common polymorphisms in the gene encoding the receptor for antimüllerian hormone (AMHR2) were associated with menopausal age,<sup>148</sup> implicating a decrease in AMH signaling that would weaken its paracrine



inhibition of primordial follicle recruitment, leading to more rapid follicular depletion.

Candidate gene approaches are based on hypotheses regarding the genes or pathways that are most likely to be associated with a certain phenotype. This approach is limited by our incomplete knowledge of the biology of reproductive aging and its genetic regulation. Genome-wide association studies (GWAS), on the other hand, aim to discover novel susceptibility loci for any disease as well as traits like age at menopause, without the limitation of a preconceived hypothesis. The first GWAS performed to identify loci involved in reproductive aging enrolled approximately 17,000 women and identified 13 loci clustered at chromosomes 5, 6, 19, and 20, associated with age at natural menopause.<sup>149</sup> A subsequent GWAS also identified the loci on chromosomes 19 and 20 and, in addition, another locus at chromosome 13, associated with the age at natural menopause.<sup>150</sup> Studies with similar approaches in 6,500 women with African ancestry and 3,500 Chinese women were consistent with the findings of earlier reports, suggesting that the timing of menopause is largely regulated in a similar fashion in different ethnic populations.<sup>151,152</sup> Subsequently, some of the genetic variants identified by these GWAS were found to be associated with early menopause in an independent cohort, suggesting that common genetic variants influencing natural menopause constitute also risk factors for early onset of menopause.<sup>153</sup> A more recent meta-analysis of age at natural menopause in nearly 40,000 women of European ancestry from 22 studies with replication in an additional 14,000 women confirmed 4 of the previously reported loci and identified 13 novel loci. The identified genes were not implicated in follicle development; instead, they were primarily associated with DNA repair and maintenance and immune function.<sup>154</sup> It is noteworthy that recent studies using whole exome sequencing identified mutations in homologous recombination and dsDNA break repair genes MCM8 and MCM9 in women with POF.<sup>155,156</sup> Careful examinations of these and other candidate genes yet to be identified likely will yield new insights and further our understanding of the mechanisms that govern reproductive aging.

## **The Aging Follicle and Oocyte**

Whereas the number of remaining ovarian follicles steadily declines with increasing age, observations in stimulated cycles suggest that aging follicles also become progressively less sensitive to gonadotropin stimulation. As age increases, the total dose and duration of treatment required to stimulate multiple follicular development increase. The rate of rise and the peak in estradiol levels decrease, reflecting the smaller cohorts of follicles that can be recruited. However, the amount of estradiol secreted by the follicles that do emerge and grow to maturity appears comparable to that in younger women.<sup>157</sup> Although a decrease in exogenous hCG-induced ovarian androgen

production can be demonstrated before the age of 30, circulating estradiol levels remain normal throughout and beyond the reproductive years, probably because rising FSH levels are able to compensate.<sup>158</sup> Studies of ovarian follicular development and preovulatory follicular fluid hormones in older and younger cycling women do not suggest any age-related decline in follicular function, once growth and development begin. Preovulatory follicles in older and younger women are similar in size and inhibin content, and follicular fluid progesterone levels and estrogen/androgen ratios are even higher in older than in younger women.<sup>83</sup>

Older cycling women ovulate as regularly and more frequently than younger women. Their rising FSH levels apparently compensate quite effectively for any decrease in follicular sensitivity to gonadotropin stimulation. Preovulatory follicles in older cycling women get an earlier start, but grow at a normal pace and reach a normal size; their follicular fluid characteristics suggest they also are quite healthy. Why then does fertility in women decline progressively with age? **The available evidence indicates that both the age-related decline in female fertility and the increase in risk of miscarriage can be attributed to an increase in the proportion of abnormal oocytes in an aging and shrinking follicular pool.**

As the number of follicles decreases, oocyte quality also declines, primarily because of an increase in meiotic nondisjunction, resulting in an increasing rate of oocyte and embryo aneuploidy in aging women.<sup>49,159,160,161</sup> A wide variety of techniques has been used to study the chromosomal composition of human oocytes. The best available evidence, derived from a detailed cytogenetic analysis of oocytes retrieved for IVF that failed to fertilize, suggests that the global rate of oocyte aneuploidy increases with advancing maternal age.<sup>162,163</sup>

As previously discussed ([Chapter 2](#)), meiosis involves a single round of DNA replication (in the premeiotic S phase), followed by two cell divisions to form gametes each with a half (or haploid) set of chromosomes. In the first meiotic division (meiosis I), duplicated chromosomes, consisting of pairs of sister chromatids, pair up with their homologues, and a synaptonemal complex is formed between them; recombination then occurs between nonsister homologous chromatids. At anaphase I, the two homologue chromosomes migrate to opposite poles. The second meiotic division (meiosis II) then follows without additional DNA replication. The pairs of sister chromatids align on the metaphase II spindle, and at anaphase II, the two sister chromatids finally separate to opposite poles resulting in daughter cells with a haploid set of chromosomes. Oocyte aneuploidy results primarily from premature separation of sister chromatids during meiosis I or from whole chromosome nondisjunction during meiosis II.<sup>163</sup> The prevalence of both types of meiotic segregation errors increases progressively with age and makes the greatest contribution to the age-dependent increase in the prevalence of

aneuploidy in human embryos.<sup>162,163,164,165,166</sup>

The European Society for Human Reproduction and Embryology (ESHRE) set up a pilot study of polar body biopsy and aneuploidy analysis in women of advanced maternal age (mean age 40.0).<sup>167</sup> Intracytoplasmic sperm microinjection was performed, and both polar bodies were biopsied and assessed simultaneously to identify errors in meiotic divisions. If aneuploidy was detected in one or both polar bodies, the corresponding presumed aneuploid fertilized oocyte or zygote was tested independently to confirm concordance with the polar body testing. This study revealed a high incidence of aneuploidies (72%), often multiple aneuploidies per zygote, resulting from an approximately equal proportion of errors in both meiotic divisions. While all chromosomes (except chromosome 3) had errors, the incidence of aneuploidy was higher for those with shorter and acrocentric chromosomes, particularly in chromosomes 11–22.

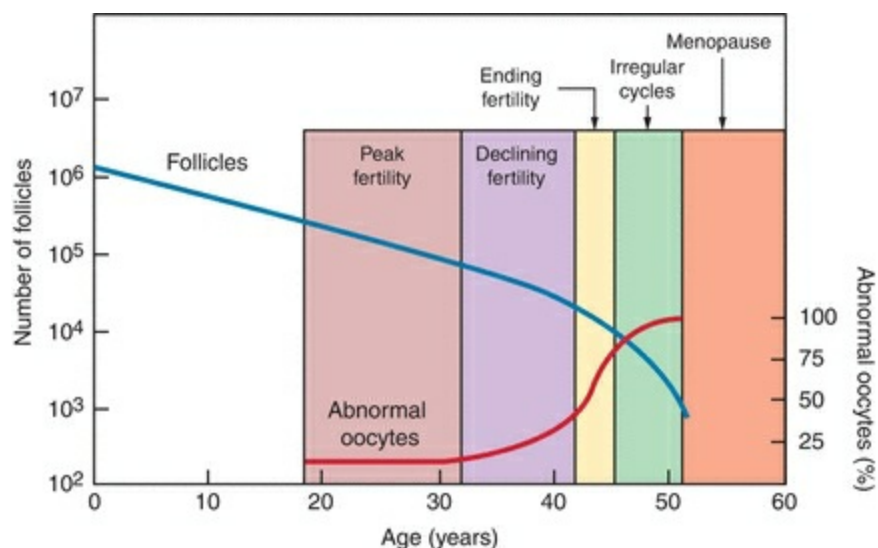
The pattern of copy number changes demonstrated that most meiosis I errors resulted from premature separation of sister chromatids as originally observed 2 decades ago,<sup>164</sup> and only 3% were caused by classical nondisjunction. In about half of cases where there had been an error in meiosis I, this error was balanced in meiosis II. Therefore, in the zygote, there were more aneuploidies resulting from errors in meiosis II than meiosis I. This pattern of multiple meiotic errors caused by premature separation of sister chromatids, and a net excess of meiosis II errors in zygotes following assisted conception, is in contrast with the low incidence of multiple aneuploidies detected in pregnancies following natural conception and the predominance of female meiosis I errors in trisomies.<sup>35,160</sup> This could suggest that the use of high doses of exogenous hormones for ovarian stimulation in older patients perturbs the process of meiosis.

An analysis of trophoctoderm biopsies from more than 15,000 human blastocysts also showed that aneuploidy rate increases with age.<sup>166</sup> This is true for all chromosomes and highest for chromosomes 15, 16, 18, 19, 21, and 22.<sup>168</sup> The age-related increase in aneuploidy was most pronounced for acrocentric chromosomes (where centromere is located near one end of the chromosome, e.g., chromosome 21).<sup>168</sup>

The age-related decrease in the proportion of normal oocytes (23,X) and the corresponding increase in the proportion of aneuploid oocytes and embryos bear striking similarity to the age-related decrease in fertility and increase in the incidence of spontaneous miscarriage in women. Fertility and the prevalence of euploid oocytes decrease progressively with age. Miscarriage risk and the prevalence of aneuploid oocytes are relatively low and change little until approximately age 35, and then increase progressively, reaching 70% at age 40 and virtually 100% after age 45.<sup>162,167</sup> These observations offer a logical explanation for the age-related increase in the prevalence of aneuploidy in spontaneous abortuses. Whereas at least half of all

clinically recognized miscarriages exhibit an abnormal karyotype and the frequency of both euploid (normal) and aneuploid (abnormal) abortuses increases with maternal age, the probability that an abortus will be chromosomally abnormal increases with age, from less than 35% at age 20 to nearly 80% over age 42.<sup>35</sup> Trisomies are by far the most common abnormality observed, followed by polyploidies and monosomy X (45,X).

Studies of meiotic segregation have revealed that factors predisposing to nondisjunction relate to the disruption of chromosomal pairing and recombination.<sup>169,170</sup> Various mechanisms have been implicated, but all involve an age-dependent deterioration in cellular factors required for proper spindle formation and function.<sup>171</sup> Molecular investigations of chromatid cohesion and separation have implicated cohesins, a specific class of proteins that maintain cohesion between sister chromatids and oppose the splitting forces mediated by the microtubules of the meiotic spindle.<sup>172,173,174,175</sup> An age-related premature degradation or deficiency of cohesins may result in unstable bivalent chromatid structures and predispose to premature separation of sister chromatids before they align on the meiotic spindle. The smaller chromosomes appear more prone to premature chromatid separation, possibly because they have fewer of the chiasma that help to prevent such dissociation.<sup>164,176,177</sup> Other studies using high-resolution confocal microscopy to examine the meiotic spindle in human oocytes have revealed that abnormalities of the cleavage spindle microtubular matrix or chromosome alignment during meiosis II are 4 to 5 times more common in older cycling women (age 40–45) than in younger women (age 20–25).<sup>49</sup> These and other observations of cultured human oocytes collected from unstimulated ovaries further indicate that the meiotic competence of oocytes declines with age.<sup>178</sup> **In sum, accumulated evidence strongly suggests that the primary cause of the age-dependent decrease in fecundability and increase in the incidence of miscarriage is an increasing prevalence of aneuploidy in aging oocytes resulting at least in part from disordered regulatory mechanisms governing meiotic spindle formation and function (Figure 25.2).**



Adapted from<sup>17, 156</sup>

Data from **Broekmans FJ, Soules MR, Fauser BC**, Ovarian aging: mechanisms and clinical consequences, *Endocr Rev* 30:465, 2009 and **Pellestor F, Andreo B, Anahory T, Hamamah S**, The occurrence of aneuploidy in human: lessons from the cytogenetic studies of human oocytes, *Eur J Med Genet* 49:103, 2006.

## Aging and the Uterus

Aging does not appear to have any significant adverse effect on the uterus. Even though benign uterine pathology (leiomyomata, endometrial polyps, adenomyosis) is more common in older women,<sup>179,180,181</sup> there is limited evidence to suggest that uterine age itself has a major impact on fertility.<sup>182,183,184,185</sup> Age also does not appear to adversely affect endometrial development or function in response to steroid stimulation.<sup>186</sup> The most reliable evidence comes from comparing outcomes in nondonor and donor oocyte IVF cycles. Whereas early studies suggested that donor oocyte IVF pregnancy and delivery rates decreased modestly with the age of the recipient,<sup>187,188,189</sup> the bulk of more recent experience refutes those conclusions.<sup>190,191</sup> In the national summary of ART success rates for the year 2015, live birth rates declined progressively with increasing age for nondonor egg cycles, as expected. In contrast, the overall live birth per transfer rate in donor egg IVF cycles was over 50% and did not vary significantly with the age of the recipient.<sup>33</sup> **Live birth rates in donor egg IVF cycles relate to the age of the donor, not the age of the recipient.** In one large series, miscarriage rates increased from 14% in women matched with egg donors aged 20–24 to 44% for women whose donors were over age 35.<sup>192</sup> However, perinatal outcomes are improved when a gestational carrier is used rather than transfer of donor embryos to an infertile patient's own uterus, even when adjusted for age.<sup>193,194</sup> There are defects in the infertile uterus as suggested above that may impact fertility and tend to accumulate with age, but aging itself is not thought to be a significant factor influencing uterine receptivity.

## Aging and Male Fertility

The relationship between age and fertility in men is discussed in detail in [Chapter 26](#) and summarized here. Several studies have shown that semen volume, sperm motility, progressive motility, and morphologically normal sperm significantly decrease with male age.<sup>195,196,197,198</sup> The data also suggest a decrease in sperm concentration and count.<sup>196</sup> However, semen characteristics generally do not accurately predict fertilizing capacity<sup>199,200,201,202</sup>; nor do endocrine parameters.<sup>203,204</sup> When the effect of male partner age on pregnancy rates is investigated, obvious confounders are female partner age and lower coital frequency due to aging. Among the few studies that have controlled for female age, pregnancy rates for men over 50 have been 23–38% lower than for men under age 30.<sup>195</sup> A British study that examined the effect of men's age on the time to conception (adjusting for the confounding effects of both partner's age and coital frequency) found that increasing men's age was associated with increasing time to conception and declining overall pregnancy rates; the time to conception was fivefold greater for men over age 45 than for men under age 25, and restricting the analysis to men with young partners yielded similar results.<sup>205</sup> Results of two studies that controlled for female partner age have suggested that male fertility may start to decline earlier, beginning in the late 30s.<sup>206,207</sup> Studies on the effect of male age on the outcome of ART cycles using donor oocytes yielded conflicting results.<sup>198,208</sup>

There are several possible biologic mechanisms that might explain an age-related decline in male fertility. Sperm chromosomal abnormalities may increase in frequency with age and adversely affect early embryonic development.<sup>209</sup> There is at least some evidence to suggest that increasing male age may raise the risk of miscarriage in young women.<sup>210</sup> In addition, there are epigenetic changes resulting in altered sperm DNA methylome in aging men.<sup>211</sup> Average FSH levels in men increase during their 30s,<sup>212</sup> suggesting that age-related changes in the hypothalamo-pituitary-gonadal axis may begin during midlife.<sup>213</sup> The testes and prostate also exhibit morphologic changes with aging that might adversely affect both sperm production and the biochemical properties of semen.<sup>214</sup> Whatever the mechanism, decreasing fertility with increasing male age in healthy couples suggests that normal sperm overproduction may not fully buffer the effects of increasing age.

**Overall, the available evidence suggests a negative correlation between male age and pregnancy rates. The time to conception increases with male age. However, because there is little or no overall measurable decline in male fertility before age 45–50, male factors generally contribute relatively little to the overall age-related decline in fertility.**

# Ovarian Reserve and Its Assessment

The term ovarian reserve refers to (1) the size and quality of the remaining ovarian follicular pool and (2) the ability of the ovaries to respond to exogenous gonadotropin stimulation, which are related concepts. Since the major effect of aging on a woman's reproductive potential is through declining oocyte number and increased oocyte aneuploidy, the concept of ovarian reserve is relevant for female reproductive aging.

There are two intentions for ovarian reserve testing: (1) to predict fecundity and (2) to gain prognostic information regarding the likelihood of successful response to ovarian stimulation in women undergoing infertility treatment.

Like all screening tests, ovarian reserve tests are aimed at identifying individuals at risk for a disease, in this case "diminished ovarian reserve" (DOR). **It is important to emphasize that such tests cannot and do not establish a diagnosis of DOR; they only identify women more likely to exhibit a poor response to gonadotropin stimulation and potentially have a lower likelihood of achieving pregnancy with treatment.** The value of a screening test depends on its validity, describing its ability to correctly categorize individuals as affected (sensitivity) or unaffected (specificity). The sensitivity and specificity of a screening test will vary with the chosen threshold value. A choice intended to maximize sensitivity minimizes the number of false-negative results (patients with DOR categorized as normal), but increases the number of false-positive results (patients with a normal ovarian reserve categorized as having DOR). Conversely, a threshold value that maximizes specificity minimizes false positives, but increases false-negative results. **For measures of ovarian reserve, test threshold values should have high specificity for DOR, so as to decrease false-positive results (incorrectly categorizing a patient with a normal ovarian reserve as having DOR), thereby avoiding overly aggressive treatment or inappropriate recommendations to abandon treatment or pursue adoption or oocyte donation in women with a normal ovarian reserve. Treating women with unrecognized DOR (the consequence of maximizing specificity) is undesirable, but a less serious error.**

The most important test characteristics of a screening test are its positive predictive value (PPV) and negative predictive value (NPV), which vary with the prevalence of the disease of interest, i.e. DOR, in the test population. PPV describes the probability that a woman with a positive test truly has DOR, and NPV is the probability that a woman with a negative test truly has a normal ovarian reserve. If the prevalence of DOR is low, as in young women, the PPV will be low, even if sensitivity and specificity are high. Conversely, if the prevalence of DOR is high, as in older women, the PPV will be high if a highly specific threshold value is chosen. **If the purpose of ovarian reserve testing is to correctly identify women with DOR, it will be most useful in**

**women at high risk for DOR. When applied in a low prevalence population, many women with a normal ovarian reserve will have a false-positive result and be categorized as having DOR.**

Ovarian reserve tests include both biochemical and ultrasonographic measures of the size and (by inference) the quality of the ovarian follicular pool. Biochemical tests include both basal measurements, such as FSH, estradiol, inhibin B, and antimüllerian hormone (AMH), and provocative tests, such as the clomiphene citrate challenge test (CCCT). Ultrasonographic measures of ovarian reserve include the antral follicle count (AFC) and ovarian volume.

It should be noted that both biochemical and ultrasonographic markers of ovarian reserve have poor predictive value for conception. Women should not be told that they cannot conceive spontaneously or should not be denied fertility-promoting treatments, including ART, based solely on finding of decreased ovarian reserve.

## **Basal FSH and Estradiol Concentrations**

Serum FSH concentration was one of the earliest and commonly used tests of ovarian reserve. Since an isolated increase in FSH levels is one of the earliest indications of reproductive aging in women, it was an obvious choice for identifying women with diminished ovarian reserve (DOR). As a marker of ovarian reserve, serum FSH concentration is best obtained during the early follicular phase (cycle days 2–4).

However, serum FSH concentration has wide intra- and intercycle variation, limiting its value as a screening test. Moreover, FSH values vary with the assay method; although values obtained with different assays correlate very well, absolute values can differ significantly. Values also vary with the reference standard, previously an International Reference Preparation of Human Menopausal Gonadotropin (IRP-HMG) and now the World Health Organization Second International Reference Preparation (IRP 78/549).

Numerous studies have investigated the relationship between cycle day 3 FSH concentrations or FSH/LH ratios and IVF cycle outcomes, all observing that these measures correlate with the ovarian response to exogenous gonadotropin stimulation and, to a lesser extent, with the likelihood for success. As FSH values increase, the peak in estradiol levels, the number of oocytes retrieved, and the probability for pregnancy or live birth steadily decline.<sup>215,216,217,218,219,220,221</sup> **With current assays (using IRP 78/549), FSH levels greater than 10 IU/L (10–20 IU/L) have high specificity (80–100%) for predicting poor response to stimulation, but their sensitivity for identifying such women is generally low (10–30%) and decreases with the threshold value.**<sup>222</sup> Although most women who are tested (including those



with DOR) will have a normal result, the test is still useful because those with abnormal results are very likely to have DOR.

Because FSH levels can vary significantly, many clinicians prefer to repeat the test. Not surprisingly, consistently high values are associated with a poor prognosis, but a single elevated FSH concentration (>10 IU/L) does not have high specificity for predicting poor response to stimulation or failure to achieve pregnancy.<sup>223</sup> Serial testing in efforts to select the ideal cycle for treatment does not improve outcomes in women with fluctuating FSH concentrations.<sup>224,225</sup>

**The basal serum estradiol concentration, by itself, has little value as an ovarian reserve test,<sup>226,227,228,229</sup> but can provide additional information that helps in the interpretation of the basal FSH level.** An early elevation in serum estradiol reflects advanced follicular development and early selection of a dominant follicle (as classically observed in women with advanced reproductive aging) and will suppress FSH concentrations, thereby possibly masking an otherwise obviously high FSH level indicating DOR. When the basal FSH is normal and the estradiol concentration is elevated (>60–80 pg/mL), the likelihood of poor response to stimulation is increased and the chance for pregnancy is decreased.<sup>230,231,232,233</sup> When both FSH and estradiol are elevated, ovarian response to stimulation is likely to be very poor.

Due to their low diagnostic performance, basal FSH and estradiol measurements are being increasingly replaced with serum AMH and AFC in daily practice.

## Clomiphene Citrate Challenge Test

The CCCT is a provocative and possibly more sensitive test of ovarian reserve that probes the endocrine dynamics of the cycle under both basal and stimulated conditions, before (cycle day 3 FSH and estradiol) and after (cycle day 10 FSH) treatment with clomiphene citrate (100 mg/day, cycle days 5–9).<sup>234</sup>

The smaller follicular cohorts in aging women produce less inhibin B and estradiol, resulting in less negative feedback inhibition on clomiphene-induced pituitary FSH release, causing an exaggerated increase in FSH concentrations.<sup>84,235</sup> Consequently, a frankly elevated cycle day 10 FSH concentration can identify women with DOR who might otherwise go unrecognized if evaluated with basal cycle day 3 FSH and estradiol levels alone.<sup>236,237</sup>

In studies evaluating CCCT results, stimulated concentrations of FSH, estradiol, and inhibin B have varied widely, limiting the value of the test.<sup>238,239,240</sup> A 2006 systematic review of the predictive value of the CCCT over a range of day 10 FSH concentrations (10–22 IU/L) in women at low, average, and high probability of DOR concluded the test

had 47–98% specificity and 35–93% sensitivity for predicting poor response to stimulation and 67–100% specificity and 13–66% sensitivity for predicting treatment failure.<sup>241</sup> **Overall, the additional value of CCCT over basal FSH and AFC is marginal, and it is being used less often in daily practice.**

## **Inhibin B**

Inhibin B is secreted primarily during the follicular phase by the granulosa cells of smaller antral follicles. Its concentrations increase in response to exogenous GnRH or FSH stimulation and show wide intra- and intercycle variation.<sup>228,242</sup> Thus, **inhibin B is generally not regarded as a reliable measure of ovarian reserve.**

Although inhibin B levels are generally lower in women who respond poorly to exogenous gonadotropin stimulation than in those who respond normally,<sup>243,244</sup> even low threshold values (40–45 pg/mL) have only 64–90% specificity and 40–80% sensitivity for predicting poor response. Inhibin B has a relatively low PPV (19–22%) but a relatively high NPV for detecting DOR in a general IVF population<sup>242,245</sup>; in a high prevalence population, the PPV of inhibin B can exceed 80%.<sup>228</sup> In most studies, inhibin B has had poor PPV for failed treatment.<sup>227,228,246,247,248</sup>

## **Antimüllerian Hormone**

Antimüllerian hormone (AMH) is produced by the granulosa cells of preantral and small antral follicles, beginning when primordial follicles start developing into primary follicles and ending when early antral follicles reach a diameter of 2–6 mm.<sup>249,250,251,252,253</sup> Small antral follicles are likely the primary source because they contain larger numbers of granulosa cells and a more developed microvasculature.<sup>254,255</sup> Although it functions primarily as an autocrine and paracrine regulator of follicle development, AMH appears in measurable amounts in the serum.<sup>256</sup> The number of small antral follicles correlates with the size of the residual follicular pool and AMH levels decline progressively, becoming undetectable near the menopause.<sup>257,258,259,260</sup>

**Because AMH derives from preantral and small antral follicles, levels were thought to be gonadotropin-independent and exhibit little variation within and between cycles.**<sup>261,262,263</sup> However, recent studies suggest AMH levels decrease with the use of oral contraceptives and GnRH agonists.<sup>264</sup> In early clinical studies, AMH has been assayed using two different commercial assay kits, and although the results were highly correlated, their standard curves were not parallel and there was no applicable conversion factor; one comparative study observed that concentrations measured with one kit were more than fourfold lower than those measured with the other.<sup>265</sup> Even

though the two manufacturers of AMH assays merged to form a third company and a new two-step, sandwich-type enzymatic microplate assay that uses a more stable antibody was introduced, the assay was calibrated to the standards of one manufacturer, and results remained systematically different, that is, 40% higher, than the previous version of the other manufacturer. Moreover, AMH readings are affected by the storage and handling conditions of the samples. Consequently, when applying results in clinical practice, it is important to know which assay method was used to measure AMH. Current commercial assay kits yield consistent results with low interassay variation (<10%).<sup>266</sup>

The performance of AMH as a screening test of ovarian reserve has been examined in the general IVF population and in populations of women at low or high risk for DOR. Overall, lower AMH levels have been associated with poor response to ovarian stimulation and low oocyte yield, embryo quality, and pregnancy rates,<sup>242,243,267,268,269</sup> but studies correlating mean AMH levels with IVF outcomes have not yielded threshold values that can be applied confidently in clinical care,<sup>226,243,245,267</sup> and more recent studies failed to show an effect of low AMH levels on pregnancy rate, when corrected for age.<sup>270,271</sup> **In the general IVF population, low AMH threshold values (0.2–0.7 ng/mL) have had 40–97% sensitivity, 78–92% specificity, 22–88% PPV, and 97–100% NPV for predicting poor response to stimulation ( $\leq 3$  follicles or  $\leq 2$ –4 oocytes), but have proven neither sensitive nor specific for predicting pregnancy.**<sup>242,272,273,274</sup>

**AMH is a very promising screening test for DOR but is likely to be more useful in a general IVF population or in women at high risk for DOR than in women at low risk for DOR. Low threshold values have good specificity for poor response to ovarian stimulation, but not for predicting pregnancy.**

## Antral Follicle Count

Reproductive-aged women have an estimated 20–150 growing follicles in the ovaries at any one time, although only those large enough to be imaged (>2 mm) can be visualized by transvaginal ultrasonography (TVUS).<sup>275,276,277</sup> Antral follicles are FSH sensitive and can progress to more advanced stages of development when stimulated with exogenous FSH. **Histologic studies have revealed that the number of small antral follicles in the ovaries is proportional to the number of primordial follicles remaining.**<sup>278</sup> **Therefore, as the supply of primordial follicles decreases, the number of visible small antral follicles also declines.** The antral follicle count (AFC; total number of antral follicles measuring 2–10 mm in both ovaries) thus provides an indirect but useful measure of ovarian reserve.<sup>276,279,280,281,282</sup>

AFC correlates with onset of the menopausal transition, indicating that it relates to the number of follicles remaining.<sup>258</sup> Some, perhaps as much as half, of the antral follicles that can be imaged are probably in the process of atresia, but there is no way other than observing their response to FSH stimulation to distinguish them from viable growing follicles.<sup>283</sup> However, AFC correlates well with oocyte yield in IVF cycles,<sup>284</sup> suggesting that gonadotropin stimulation can still rescue follicles that may be in the early stages of atresia.<sup>285</sup> Several studies have observed a relationship between the AFC and response to ovarian stimulation in IVF cycles. In the general IVF population, including women at low and high risk for DOR, an AFC threshold value of three to four follicles has high specificity (73–100%) for predicting poor response to ovarian stimulation and failure to conceive (64–100%), but relatively low sensitivity for both endpoints (9–73% for poor response, 8–33% for failure to conceive).<sup>228,284,286,287,288,289,290,291</sup> The PPV and NPV of AFC have varied widely in studies.

**A low AFC has high specificity for predicting poor response to ovarian stimulation and treatment failure, making it a useful test, but low sensitivity limits its overall clinical utility.**

## Ovarian Volume

Not surprisingly, ovarian volume decreases with progressive follicular depletion.<sup>292,293</sup> However, the measure has high intercycle and interobserver variability,<sup>228,294,295,296</sup> and because most studies of ovarian volume have excluded women with ovarian pathology such as endometriomas and polycystic ovary syndrome, results have limited generalizability.<sup>293,297</sup>

Ovarian volume (length × width × depth × 0.52 = volume) generally correlates with the number of oocytes retrieved, but poorly with pregnancy.<sup>286,291,298,299,300</sup> A low ovarian volume (<3 mL) has high specificity (80–90%) and widely ranging sensitivity (11–80%) for predicting poor response to ovarian stimulation.<sup>222</sup> The PPV for poor response can be as low as 17% among women at low risk for DOR and as high as 53% in women at high risk.<sup>228</sup> **Overall, ovarian volume has very limited clinical utility as an ovarian reserve test.**

## Other Tests of Ovarian Reserve

Numerous other provocative tests of ovarian reserve have been investigated, including exogenous FSH-stimulated estradiol, inhibin B or AMH levels,<sup>267,301,302,303,304,305</sup> and GnRH agonist-stimulated FSH, estradiol, inhibin B, or AMH

concentrations.<sup>267,301,306,307,308</sup> In theory, the ovarian and endocrine response to FSH or GnRH agonist stimulation should provide the best estimate of the number of responsive follicles. **However, the available evidence does not justify the complexity and higher costs of these tests since they are not found to be better predictors of response to ovarian stimulation or pregnancy than basal FSH, AMH, and AFC.**<sup>222</sup>

## Combined Tests of Ovarian Reserve

Since none of the ovarian reserve tests alone has 100% sensitivity and specificity, varying combinations of ovarian reserve tests have been tried to improve diagnostic performance. However, as different tests of ovarian reserve are highly correlated, using more than one measure in a prediction model does not necessarily improve its performance.<sup>228,244,286</sup> The use of combined tests will not only increase the cost of testing but also complicate clinical decision-making. A combination of AMH, inhibin B, AFC, and ovarian volume was not found to be a better predictor of response to stimulation than only AFC and AMH alone.<sup>289</sup> A meta-analysis of cohort studies investigating the performance of various combinations of tests concluded that models combining tests do not perform significantly better than individual tests such as the AFC.<sup>309</sup>

## Summary

Currently, there is no ovarian reserve test that predicts the likelihood of spontaneous conception for a regularly menstruating woman. For the purpose of predicting response to ovarian stimulation, the lack of a uniformly accepted definition of diminished ovarian reserve despite a number of attempts remains a problem. In order to predict success of ART, the ideal ovarian reserve test should yield consistent results and be highly specific, to minimize the risk for incorrectly categorizing normal women as having a diminished ovarian reserve. Currently, AFC and antimüllerian hormone are replacing basal FSH levels as the most commonly used ovarian reserve test in clinical practice.

Although ovarian reserve tests are capable of predicting response to exogenous gonadotropin stimulation reasonably well, whether the information gained truly affects outcomes is less certain. Individualized FSH dosing based on ovarian reserve testing does not seem to improve live birth rates or decrease cost of treatment.<sup>310,311,312</sup> **Moreover, increasing gonadotropin dosage does not improve response predictably in women with diminished ovarian reserve, probably because the small cohort of responsive antral follicles is the limiting factor and no amount of stimulation can increase that number appreciably.**<sup>313,314,315</sup> Even in women who previously exhibited a poor response to stimulation, changes in treatment regimens generally have not

improved response or pregnancy rates in subsequent cycles.<sup>314,316,317,318</sup>

**None of the ovarian reserve tests currently in use is an accurate predictor of pregnancy in IVF cycles, with the possible exception of when extreme abnormal threshold values are applied, which results in very low sensitivity for identifying women having a poor prognosis.**<sup>319</sup> The tests are adequate for predicting poor response, which does have prognostic value, although not as much in young women as in older women.<sup>320,321,322</sup> Although ovarian reserve tests have become a routine element of pretreatment evaluation for couples planning IVF, it can be argued that routine testing has limited clinical utility in the large majority of patients and can be misleading, especially in women at low risk for having a diminished ovarian reserve.<sup>283</sup>

Ovarian reserve tests also have become a routine element of the diagnostic evaluation for infertility. Advocates for the liberal application of ovarian reserve tests argue that abnormal tests can help to persuade older women to abandon plans to pursue aggressive, costly, and likely futile treatment and can help to convince young women to do just the opposite, to take fullest advantage of a rapidly closing window of opportunity. Others more circumspect emphasize correctly that few young women will have an abnormal test, and some of those who do inevitably will be categorized incorrectly, leading to inappropriate counseling and treatment. **The best overall strategy would seem to limit ovarian reserve testing to women at increased risk for having a diminished ovarian reserve and to apply highly specific threshold values to minimize the risk for a false-positive result.** In this context, ovarian reserve testing can best be justified for women with any of the following characteristics<sup>138,323,324,325,326</sup>

- Age over 35
- Unexplained infertility to identify unsuspected loss of ovarian reserve
- Family history of early menopause
- Previous ovarian surgery (ovarian cystectomy or drilling, unilateral oophorectomy), chemotherapy, or radiation
- Smoking
- Demonstrated poor response to exogenous gonadotropin stimulation

**Ovarian reserve tests always should be interpreted with caution. Rigid application of test results risks inappropriate recommendations for treatment, or for no treatment, and both must be avoided. An abnormal test result does not preclude the possibility of pregnancy. Except perhaps when grossly abnormal, test results should not be used to deny treatment, but only to obtain prognostic information that may help to guide the choice of treatment and best use of available resources. Although the probability of pregnancy may be low, many with abnormal test results**

**will achieve pregnancy if afforded the chance. Ultimately, regardless of the prognosis, the success rate for any individual woman will be 0% or 100%.**

# GUIDING PRINCIPLES FOR EVALUATION AND TREATMENT OF INFERTILITY

---

From the beginning, the evaluation of infertility should focus on the couple and not on one or the other partner, regardless of past reproductive performance. Ideally, both partners should be present during office visits. This enables the flow of information between the physician and both partners, as well as between the partners. It is equally important to allow each partner to express her or his own opinion and be able to ask questions directly. This can help increase patient compliance, which is very often a challenging aspect of the management of infertile couples.

**The four basic goals of management of infertility are:**

- **To identify and to correct specific causes of infertility, when possible. With proper evaluation and treatment, the majority of women will achieve pregnancy.**
- **To provide accurate information and to dispel the misinformation commonly gained from friends, mass media, and the Internet.**
- **To provide emotional support during a trying time.**

In many couples, the inability to conceive results in feelings they have lost control over an important and very personal part of their lives. The process of evaluation and the associated uncertainty significantly adds to that burden. Infertile couples often need the opportunity to express their concerns, frustrations, and fears, and support groups can help to meet that need. Group meetings can help couples to realize that their problem is not unique and to learn how others cope with similar problems. Whereas severe anxieties can have adverse effects on ovulatory function and coital frequency, there is no substantial evidence that the usual anxieties of couples trying to conceive cause or contribute to their infertility.

- **To guide couples failing to conceive with other forms of treatment to alternatives, including IVF, the use of donor gametes (oocytes or sperm), and adoption, and to help those who reject or fail treatment to come to closure.**

Counseling must be an ongoing process during both evaluation and treatment. Regular visits to review and critique results and to outline recommendations for further evaluation and treatment help to ensure that all of the couple's medical, emotional, and financial needs and concerns are addressed effectively in a timely fashion.



# Lifestyle and Environmental Factors

Understandably, all infertile couples are very interested in learning anything they might do to maximize the likelihood of achieving a successful pregnancy. Lifestyle choices and environmental factors influence fertility and deserve consideration and discussion when they are relevant. The United States has the highest obesity rate in the world. Over 40% of American women are obese and another 30% are overweight.<sup>327</sup> Obesity is defined as a body mass index (BMI) greater than 30 kg/m<sup>2</sup> and overweight is defined as a BMI between 25 kg/m<sup>2</sup> and 30 kg/m<sup>2</sup>. In women, obesity is associated with menstrual dysfunction, decreased fertility, and increased risks of miscarriage and obstetric and neonatal complications. In men, obesity is associated with abnormal semen parameters and can adversely affect fertility.<sup>328</sup>

Substance abuse is one of the few things over which the couple may have specific control, smoking being the most important. Many are not aware of the adverse effects smoking has on fertility and pregnancy outcome.<sup>329</sup> The couple's motivation to maximize their fertility presents a golden opportunity to educate those who smoke and to establish a smoking cessation strategy. Smoking has well-known adverse impact on pregnancy outcome, and evidence strongly suggests that fertility is lower in both men and women who smoke.<sup>330,331,332,333,334</sup> The prevalence of infertility is higher, fecundability is lower, and the time to conception is longer in smoking than in nonsmoking women, and the effects of passive smoke exposure are only slightly less than those of active smoking by either partner.<sup>335</sup> The available data suggest that the adverse effects of smoking on fertility are dose-dependent.<sup>331,336,337,338</sup> The mechanisms involved may include accelerated follicular depletion,<sup>339,340,341</sup> menstrual cycle abnormalities,<sup>342</sup> or gamete or embryo mutagenesis induced by toxins in cigarette smoke.<sup>343,344,345,346,347</sup> A causal relationship between cigarette smoking and female infertility has not been established. However, based on the results of a meta-analysis including 12 studies (overall OR for risk of infertility in women smokers versus nonsmokers 1.60),<sup>333</sup> and assuming a 22.5% prevalence of smoking in women of reproductive age, up to 12% of female infertility could be related to smoking.<sup>348,349</sup> Consequently, an active approach to prevention of infertility is justified, discouraging smoking and helping those who smoke to quit.<sup>350</sup>

Other forms of substance abuse also can adversely affect fertility. Marijuana inhibits the secretion of GnRH and can suppress reproductive function in both women and men.<sup>351</sup> In women, marijuana use can interfere with ovulatory function.<sup>352</sup> Cocaine use can impair spermatogenesis in men<sup>351,353</sup> and has been associated with a greatly increased risk of tubal disease in women.<sup>352</sup> Heavy alcohol consumption in women may decrease fertility<sup>354,355,356</sup>; in men, it has been associated with decreased semen quality

and impotence.<sup>357</sup> Conflicting evidence suggests that moderate alcohol intake can reduce fecundability.<sup>358,359</sup> In both women and men, even modest amounts of alcohol consumption have been associated with lower pregnancy rates in IVF cycles.<sup>360</sup> Although moderate caffeine ingestion (200 mg daily, which is equal to about one 12-ounce cup of coffee) appears not to have any adverse effects on fertility, higher levels of consumption may delay conception<sup>334,361,362</sup> or increase the risk of pregnancy loss.<sup>363,364</sup>

Other potentially harmful occupational and environmental exposures, although uncommon, may be identified. Exposures to perchlorethylene in the dry-cleaning industry, toluene in the printing business, ethylene oxide, and mixed solvents have been associated with decreased fecundity. Semen abnormalities have been described in men exposed to radiant heat or heavy metals. Environmental exposure to herbicides or fungicides has been associated with decreased fertility in women<sup>356</sup> and exposure to pesticides and other chlorinated hydrocarbons with an increased risk of miscarriage.<sup>365</sup>

**For couples attempting to conceive, there is fair evidence to support recommendations for smoking cessation and efforts to achieve a BMI between 20 and 25 kg/m<sup>2</sup>. Recommendations to limit alcohol consumption to four or fewer drinks per week and to limit caffeine intake to less than 200 mg/day also are reasonable and consistent with available evidence. However, there have been no randomized controlled trials demonstrating that such lifestyle modifications improve fertility.**

# Normal Reproductive Efficiency

Explaining normal human reproductive process helps to provide perspective for infertile couples. Understanding the relative inefficiency of human reproduction can help decrease the couple's stress and set realistic expectations regarding the assessment and treatment process. **In normally fertile couples, cycle fecundity averages 20% and does not exceed approximately 35% even when coitus is carefully timed.**<sup>207,366,367</sup>

This information is particularly helpful when discussing and comparing the efficacy of different treatment options, typically viewed in terms of cycle fecundability. It is important to ensure that couples realize that the benchmark for comparison is 20–30%, and not 100%.

Given the average 20% cycle fecundability, the cumulative pregnancy rates observed over time in normal fertile couples are easy to understand. The data in [Table 25.1](#) have been a standard since 1956 and have been confirmed by more recent studies.<sup>3,368,369</sup>

## **TABLE 25.1 Time Required for Conception Among Couples Who Will Attain Pregnancy**

Months of Exposure	% Pregnant
--------------------	------------

3 mo	57%
------	-----

57%
-----

6 mo	72%
------	-----

72%
-----

1 y	85%
-----	-----

85%
-----

2 y	93%
-----	-----

93%
-----

Data from **Guttmacher AF**, Factors affecting normal expectancy of conception, JAMA 161:855, 1956.

**A normal sperm can survive in the female reproductive tract and retain the ability to fertilize an egg for at least 3 and up to 5 days, but an oocyte can be fertilized successfully for only approximately 12–24 hours after ovulation.<sup>370</sup> Consequently, virtually all pregnancies result from intercourse occurring sometime within the 6-day interval ending on the day of ovulation.<sup>207,367,371</sup>** Estimates of when fertility peaks vary with the method used to determine the time of ovulation. When ovulation is assumed to occur on the day before the midcycle rise in basal body temperature (BBT), the day of peak fertility falls 2 days prior to ovulation<sup>207</sup>; ovulation generally occurs within 1 day of that predicted.<sup>371</sup> When the time of ovulation is based on daily urine estrogen concentrations, the probability of conception increases steadily as ovulation nears and peaks on the day before and day of ovulation,<sup>367,371</sup> ranging from about 10% at its low to approximately 33% at its peak. When daily urinary LH excretion is monitored to detect the midcycle surge that triggers ovulation, follicular collapse (as determined by serial TVUS) and, presumably, ovum release generally follow within 14–26 hours, and almost always within 48 hours.<sup>372,373</sup> Regardless of the method used, all studies indicate that fertility plummets almost immediately thereafter, declining to near zero within 24 hours after ovulation.

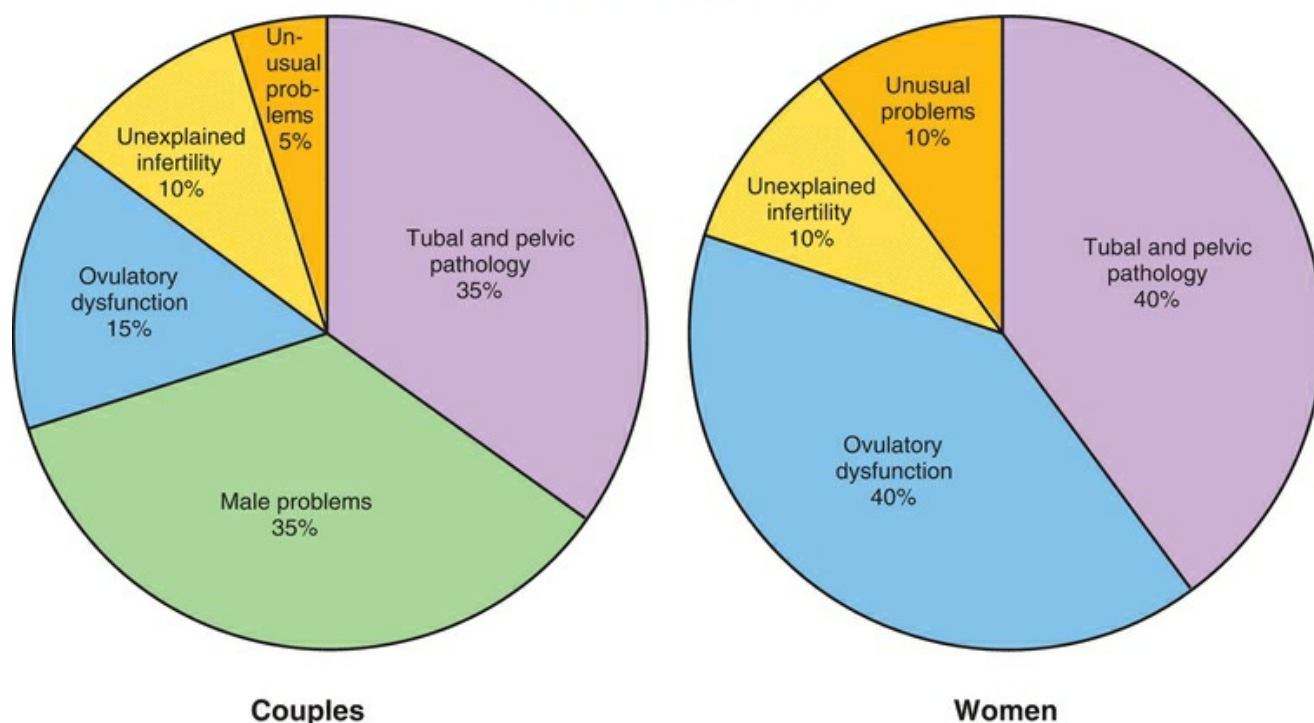
Even though timing coitus to coincide with the most fertile period seems straightforward and is frequently recommended to infertile couples as a means to increase the likelihood of pregnancy, there is very low-quality evidence to support the recommendation.<sup>374</sup> Although BBT and ovulation predictor kits (that measure elevations in urinary LH) can help define the time of ovulation, they should be used only when

necessary. Scheduled intercourse clearly adds to the already significant stress of infertility. Moreover, much of the interval of peak fertility during the menstrual cycle may be inadvertently excluded while awaiting the appropriate “signal.” **For most couples, the simple recommendation for intercourse approximately once every 2–3 days can avoid an unnecessary source of stress while also helping to ensure that coitus occurs during the interval of highest fertility.**<sup>375</sup> However, timed coitus may be a reasonable recommendation for couples having infrequent intercourse, by preference or because of circumstance.

# Causes of Infertility

Before any formal investigation begins, the major causes of infertility and the basic components of the infertility evaluation should be outlined for the couple. **The major causes of infertility include ovulatory dysfunction (20–40%), tubal and peritoneal pathology (30–40%), and male factors (30–40%); uterine pathology is relatively uncommon, and the remainder is largely unexplained.** Many couples suffer from multiple etiologies. The prevalence of each cause of infertility varies with age. Ovulatory dysfunction is more common in younger than in older couples, tubal and peritoneal factors have a similar prevalence, and male factors and unexplained infertility are observed somewhat more often in older couples.<sup>376,377</sup> The distribution of causes also varies with the duration of infertility and the level of care.<sup>378,379,380</sup> Most couples seeking evaluation have been trying to conceive for 2 or more years, so few will be normally fertile (**Figure 25.3**). Those with longer durations of infertility generally have more severe or multiple problems and tend to congregate in tertiary care centers. The average duration of infertility for couples seen in tertiary care centers (42 months)<sup>380</sup> is twice that for couples seen in the primary care setting (21 months).<sup>378</sup> Predictably, the proportion of couples with easily treatable ovulatory dysfunction decreases from primary to tertiary care, and that with more severe tubal/peritoneal or male factors increases.

Causes of Infertility



## FIGURE 25.3

The human reproductive process is complex, but for purposes of evaluation, it can be dissected into its most important and basic components.

### Key Points: Human Reproductive Process

- Sperm must be deposited at or near the cervix at or near the time of ovulation, ascend into the fallopian tubes, and have the capacity to fertilize the oocyte (male factor).
- Ovulation of a mature oocyte must occur, ideally on a regular and predictable basis (ovarian factor).
- The fallopian tubes must capture ovulated ova and effectively transport sperm and embryos (tubal factor).
- The uterus must be receptive to embryo implantation and capable of supporting subsequent normal growth and development (uterine factor).

The infertility evaluation is designed to isolate and test the integrity of each component, insofar as that is possible, and to identify any abnormalities that might impair or prevent conception. The pace and extent of evaluation should be based on the couple's age, duration of infertility, medical history, physical examination, and preferences.

Some infertility problems once considered insurmountable are now amenable to modern treatments. IVF can effectively bypass irreparable tubal occlusive disease, and intracytoplasmic sperm injection (ICSI) can overcome even severe abnormalities of semen quality. Treatments aimed at increasing gamete density—bringing together more than the usual numbers of oocytes and sperm in the right place at the right time—can increase cycle fecundability for couples with age-related or otherwise unexplained infertility and include ovarian stimulation with IUI or IVF. In women with POF, women beyond normal reproductive age, and women without ovaries, IVF using donor oocytes is highly successful.

A substantial proportion of subfertile couples suffer from unexplained infertility (i.e., have normal semen analysis, at least one patent tube, macroscopically normal-appearing uterus and endometrium, and regular menstrual cycle); similarly, a rational treatment does not exist for some common causes of infertility (i.e., advanced female age, severe tubal damage, idiopathic oligoasthenospermia).<sup>6</sup> **The scope and sequence of the modern infertility evaluation have shifted focus, from always making a**

**specific diagnosis to using the most efficient and cost-effective tests. Likewise, the focus of treatment for infertility also has shifted, from systematic correction of each identified factor to applying the most efficient and cost-effective therapy, which often is ART.**



# Indications for Evaluation

When should a formal evaluation for infertility begin? After all, most infertile couples are only subfertile, not truly sterile, and many will conceive, eventually, without treatment. Infertility has a significant spontaneous cure rate that varies with female partner age, duration, past conception history, and the cause(s). **The probability for achieving a live birth without treatment decreases with increasing age and duration of infertility.**<sup>378,379,380,381,382,383</sup> Overall, the likelihood of pregnancy without treatment declines by about 5% for each additional year of female partner age and by 15–25% for each added year of infertility.<sup>380</sup> **The largest majority of spontaneous pregnancies occur within 3 years; thereafter, the prognosis for success without treatment is relatively poor.** Couples that have conceived before generally have a better prognosis than those who have never achieved pregnancy. The cause of infertility also affects the prognosis for success without treatment but, of course, cannot be determined without evaluation. Predictably, the diagnoses of anovulation and unexplained infertility have the best prognosis. The likelihood for success without treatment for couples with male factors, tubal disease, and endometriosis varies widely with the severity of disease; the prognosis is reasonably good for mild oligospermia, tubal adhesions, and mild endometriosis and quite poor for severe male factors, tubal obstruction, and severe endometriosis.

**Evaluation should be offered to all couples who have failed to conceive after a year or more of regular unprotected intercourse, but a year of infertility is not a prerequisite for evaluation. Earlier evaluation is justified in the presence of obvious risk factors, such as irregular or infrequent menses, history of pelvic infection, surgery or endometriosis, or having a male partner with known or suspected poor semen quality, and also is warranted after 6 months of unsuccessful effort for women over the age of 35 years.**<sup>1,384</sup>

Education should be offered to any couple who seeks it, regardless whether they have made any active effort to conceive. It is always helpful to explain the reproductive process, to inform couples that normal cycle fecundability is approximately 20% (far lower than most realize), and to discuss the relationship between age and fertility, when it is relevant. In concerned couples who have not yet truly tested their fertility and have no obvious problems, some basic preliminary evaluation is reasonable to perform, if requested. A complete medical history helps in identifying or ruling out obvious risk factors, and tests to confirm ovulation and semen analysis are easy, inexpensive, and minimally invasive and quickly can identify some of the most common reproductive problems. In women at risk for diminished ovarian reserve, an ovarian reserve test is also reasonable, because results may help to determine when and how further evaluation

and treatment should be recommended.

# PRELIMINARY EVALUATION OF THE INFERTILE COUPLE

---

Any evaluation of infertility must begin with a careful history and physical examination, which often will identify symptoms or signs that suggest a specific cause and help to focus evaluation on the factor(s) most likely responsible. In the female partner, relevant medical history and physical findings are noted in [Table 25.2](#).<sup>384</sup>

## **TABLE 25.2 History and Examination of the Female Partner**

## History

- Obstetric history including gravidity, parity, pregnancy outcomes, and associated complications.
  - Menstrual history including cycle length and characteristics and onset and severity of dysmenorrhea.
  - Coital frequency and sexual dysfunction.
  - Duration of infertility and results of any previous evaluation and treatment.
  - Medical and surgical history, including episodes of pelvic inflammatory disease or exposure to sexually transmitted infections.
  - Previous abnormal cervical cancer screening results and subsequent treatment.
  - Current medications and allergies.
  - Occupation and use of tobacco, alcohol, and other drugs.
  - Family history of birth defects, mental retardation, early menopause, or reproductive failure.
  - Symptoms of thyroid disease, pelvic or abdominal pain, galactorrhea, hirsutism, or dyspareunia.
- 

## Physical Examination

- Weight and BMI.
  - Thyroid enlargement, nodule, or tenderness.
  - Breast secretions and their characteristics.
  - Signs of androgen excess.
  - Pelvic or abdominal tenderness, organ enlargement, or mass.
  - Uterine size, contour, position, and mobility.
  - Vaginal or cervical abnormality, secretions, or discharge.
  - Mass, tenderness, or nodularity in the adnexa or cul-de-sac.
-

Irregular or infrequent menses indicate ovulatory dysfunction. Previous treatment for cervical intraepithelial neoplasia or observation of a mucopurulent cervicitis or cervical stenosis helps to identify unusual women in whom the cervix may present an obstacle. A history of previous hysteroscopic or reconstructive uterine surgery or recently developing symptoms of menorrhagia suggest an abnormality of the uterine cavity; previous uncomplicated first- and second-trimester pregnancy terminations generally do not adversely affect subsequent fertility.<sup>385,386</sup> Worsening dysmenorrhea, new onset of dyspareunia, or physical findings of focal tenderness or cul-de-sac nodularity suggest endometriosis. A history of pelvic infection, septic abortion, ruptured appendix, ectopic pregnancy, abdominal myomectomy, or adnexal surgery should raise suspicion for tubal or peritoneal disease.

# Screening Tests

**Cervical cancer** screening is recommended for all sexually active women of reproductive age who have a cervix. The date and results of the most recent screening should be documented and a new one performed, if needed. The optimal method of screening depends on previous history and age.<sup>387</sup> A blood type, Rh factor, and antibody screening (in Rh-negative women) also is recommended, if not already known.

The American College of Obstetricians and Gynecologists recommend that all women considering pregnancy should be offered carrier screening for cystic fibrosis and spinal muscular atrophy, as well as a complete blood count and screening for thalassemias and hemoglobinopathies.<sup>388</sup> Women with a family history of fragile X-related disorders or intellectual disability suggestive of fragile X syndrome or women with premature ovarian insufficiency should be offered fragile X permutation carrier screening.<sup>388</sup> Additional screening also may be indicated based on family history or specific ethnicity; an example is the Ashkenazi Jewish population where an expanded carrier screening for a number of recessive disorders is indicated. Couples with consanguinity should be offered genetic counseling to discuss the increased risk of recessive conditions being expressed in their offspring and the limitations and benefits of carrier screening. When a woman is found to be a carrier for a specific condition, her reproductive partner should be offered screening to provide accurate genetic counseling regarding risk of an affected child if he tests positive and reproductive options (e.g., donor gametes, preimplantation genetic diagnosis, prenatal diagnosis).<sup>388</sup>

All women attempting pregnancy with undocumented previous rubella infection or vaccination should be tested for immunity and vaccinated if seronegative.<sup>389</sup> As there has never been a documented case of congenital rubella syndrome attributed to vaccine, the CDC has determined that women need not avoid pregnancy for more than 1 month after vaccination.<sup>390</sup> The CDC also recommends that all women without history of previous infection or evidence of immunity or vaccination against varicella (chicken pox) receive two doses of vaccine and avoid pregnancy for 1 month after each dose.<sup>389</sup>

Screening for **sexually transmitted infections** (STIs) is recommended for all women at moderate to high risk for infection. Decisions regarding STI screening should consider that current recommendations from the CDC include screening all pregnant women for syphilis (rapid plasma reagin, RPR), hepatitis B (hepatitis B surface antigen, HBSAg), and human immunodeficiency virus type 1 (HIV-1), unless the woman declines the latter, at the first prenatal visit.<sup>391</sup> Chlamydia and gonorrhea screening (nucleic acid-based tests) is recommended for all pregnant women younger than 25 years or older women at increased risk of infection.<sup>391</sup> For women receiving inseminations of donor sperm, the American Society for Reproductive Medicine (ASRM) considers

syphilis, hepatitis B and C, HIV-1, HIV-2, chlamydia, gonorrhea, and cytomegalovirus (CMV) screening mandatory and recommends screening for human T-cell lymphotropic virus (HTLV) types I and II at the discretion of the physician.<sup>392</sup> For male partners of women receiving inseminations of donor sperm, the ASRM strongly recommends HIV-1 and HIV-2 and recommends other STI screening similar to the female partner. For recipients of donor oocytes or embryos and their male partners, the ASRM recommends screening for syphilis, hepatitis B and C, HIV-1, HIV-2, chlamydia, gonorrhea, and CMV.<sup>392</sup> Any additional screening laboratory tests should be directed by the medical history and clinical judgment.

# MALE FACTOR: ABNORMALITIES OF SEMEN QUALITY

---

The evaluation and treatment of male infertility are the focus of [Chapter 26](#), but must be addressed briefly here because male factors explain or contribute significantly to infertility in up to 35% of couples. Semen analysis is therefore always an appropriate and important initial step in the evaluation of the infertile couple. In the absence of any known genital abnormality, trauma, surgery, or sexual dysfunction, physical examination of the male partner can be deferred pending the results of the initial semen analysis.

When semen analysis yields equivocal results, additional analyses are required to better define a suspected abnormality. A frankly abnormal semen analysis is an indication for additional evaluation that may be conducted by a gynecologist having the necessary training and experience, but most often is performed by a urologist or other specialist in male reproduction.<sup>393</sup> Invasive diagnostic procedures, including hysterosalpingography (HSG), in the female partner generally can be deferred until evaluation of the male is completed. The range of effective treatment options for couples with severe male factor infertility is limited and often will direct or even dictate what additional evaluation may be relevant in the female partner. When semen quality is normal, attention naturally turns to the female partner.



# OVARIAN FACTOR: OVULATORY DYSFUNCTION

---

Overall, disorders of ovulation account for approximately 15% of the problems identified in infertile couples. Ovulatory dysfunction can be severe enough to prevent conception (anovulation), or only a contributing factor (oligo-ovulation). However, because cycle fecundability averages only approximately 20% even in normally fertile couples, the distinction is moot.

A number of methods can be used to determine if and when ovulation occurs. Directly or indirectly, all are based on one or another of the hormonal events that characterize the normal ovulatory cycle ([Chapter 5](#)). Each of the available tests is useful and no one test is necessarily best. Some are simple, noninvasive, and inexpensive, and others are more complicated, invasive, and costly. A few can predict when ovulation is likely, with varying accuracy. However, no test, regardless how sophisticated, can prove that ovulation has actually occurred; the only positive proof that assures the occurrence of ovulation is pregnancy. The most appropriate test to use varies with the information required. The same tests used to diagnose anovulation can be used to assess the effectiveness of treatment.

# Menstrual History

Menstrual history alone often is sufficient to establish a diagnosis of oligo-/anovulation. Ovulatory women generally have regular, predictable menstrual cycles between 21 and 35 days, with menstrual flow that is consistent in volume and duration, and typically accompanied by a recognizable pattern of premenstrual and menstrual symptoms. Conversely, menstrual cycles in anovulatory women generally are irregular, unpredictable, or infrequent, vary in flow characteristics, and exhibit no consistent pattern of menses. **Women with regular menses are almost always ovulatory. Women with irregular or infrequent menses may ovulate, but not consistently, and do not require specific diagnostic tests to prove what is already obvious.**

# Basal Body Temperature

BBT is body temperature under basal conditions, at rest. For practical purposes, BBT is measured each morning, upon awakening and before arising. Traditionally, BBT is measured with an oral glass-mercury thermometer having an expanded scale, typically ranging from 96.0 to 100.0 degrees Fahrenheit and marked in tenths of one degree; modern electronic thermometers are a suitable alternative, but only if they have the necessary accuracy and precision. As a test of ovulation, daily BBT recordings are based on the thermogenic properties of progesterone; as levels rise after ovulation, BBT also increases. The effects are more qualitative than quantitative, are subtle but nonetheless distinct, and generally easy to detect when daily BBT recordings are plotted on graph paper.<sup>394</sup> **Synthetic progestins commonly used to induce menses in amenorrheic women (medroxyprogesterone acetate, norethindrone acetate) have similar thermogenic properties and also raise BBT.** A BBT rise in a woman taking a progestin should not be confused with ovulation.

BBT is typically low and fluctuates between 97.0 and 98.0 degrees during the follicular phase of the cycle, modestly but distinctly higher (0.4–0.8 degrees) during the luteal phase, and falls again to baseline levels just before or after the onset of menses. In ovulatory women, a “biphasic” pattern usually is readily evident. **The ideal BBT recording is distinctly biphasic and reveals a cycle between 25 and 35 days in length, with menses beginning 12 days or more after the rise in temperature.** When pregnancy occurs in a monitored cycle, the onset of menses is delayed and BBT remains elevated, reflecting the sustained production of progesterone by the corpus luteum stimulated by hCG.

BBT recordings provide objective evidence of ovulation and also reveal the approximate time of ovulation. Unfortunately, the temporal relationship between the thermogenic shift in BBT and ovulation frequently is misunderstood. BBT generally falls to its lowest level on the day before or day of ovulation, but the nadir in BBT cannot be reliably identified until after the temperature rises and remains elevated.<sup>395</sup> The shift in BBT occurs when progesterone concentrations rise above approximately 3–5 ng/mL, 1–5 days after the midcycle LH surge and up to 4 days after ovulation.<sup>396</sup> The temperature rise usually is somewhat abrupt, but may be gradual and difficult to define, and once apparent (2 or more days of temperature elevation), the most fertile interval has passed. **In cycles monitored with BBT, the interval of highest fertility spans the 7-day interval immediately before the midcycle rise in BBT.** Much of the uncertainty in predicting the time of ovulation can be avoided by reviewing a series of recordings, noting the earliest and latest days of the cycle on which the temperature shift occurred. **Coital timing can be optimized by suggesting intercourse on alternate days**

**beginning 7 days before the earliest observed rise in BBT and ending on the latest day it has been observed.**

The principal advantage that BBT has over other tests of ovulation is low cost. However, some find it stressful, serving as a daily reminder of unsuccessful efforts to conceive, each day beginning with thoughts of a family not yet realized. Since BBT cannot reliably define the time of ovulation and can become tedious, it is not the method of choice for evaluating ovulatory function for most infertile women.<sup>384</sup>

# Serum Progesterone Concentration

**A serum progesterone measurement is the simplest, most common, objective, and reliable test of ovulatory function, as long as it is appropriately timed.** Progesterone levels generally remain below 1 ng/mL during the follicular phase, rise slightly on the day of the LH surge (1–2 ng/mL) and steadily thereafter, peak 7–8 days after ovulation, and decline again over the days preceding menses. **A progesterone concentration less than 3 ng/mL implies anovulation, except when drawn immediately after ovulation or just before the onset of menses, when lower levels naturally might be expected.**<sup>397,398</sup>

When is the best time to measure the serum progesterone concentration to document ovulation? **Ideally, the serum progesterone level should be drawn approximately 1 week before the expected onset of menses, when the concentration is at or near its peak. Contrary to popular belief and practice, cycle day 21 is not always the best time to measure the serum progesterone concentration.** Cycle day 21 is a good choice for women with cycles lasting approximately 28 days, but a poor choice for women with 35-day cycles. The normal ovulatory cycle is 25–35 days long and exhibits a 13–15-day luteal phase. At the extremes of normal, ovulation may occur as early as cycle day 10 (in a 25-day cycle) and as late as day 22 (in a 35-day cycle). If ovulation occurs on cycle day 10, day 21 falls 11 days after ovulation, well after progesterone concentrations peak and when they are again nearing basal levels. If ovulation occurs on cycle day 22, day 21 falls 1 day **before** ovulation, when progesterone levels have not yet started to rise. **The best time to test will vary with the overall length of the menstrual cycle, aiming for approximately 1 week before the expected menses. If the menses does not commence 7 days after a serum progesterone reading of less than 3 ng/mL, it may be reasonable to repeat the test.**

Serum progesterone levels also have been used to evaluate the quality of luteal function. Whereas the amount and duration of progesterone production certainly do reflect the functional capacity of the corpus luteum, a truly accurate measure requires frequent serum progesterone determinations that are costly and impractical.<sup>399,400,401</sup> Judgments based on limited sampling, regardless how well timed, have numerous pitfalls and cannot define the quality of luteal function reliably.<sup>399,402,403,404,405,406</sup> **There is no consensus on minimum serum progesterone concentration that defines normal luteal function.** A midluteal serum progesterone level greater than 10 ng/mL is a popular standard,<sup>407</sup> but the concentrations observed in normal and abnormal cycles and in conception and nonconception cycles in both fertile and infertile women vary widely and overlap greatly.<sup>408</sup> One reason is that progesterone is secreted by the corpus luteum in distinct pulses, temporally linked to pulsatile LH secretion<sup>409,410</sup>; levels ranging from

as low as 4 ng/mL to as high as 40 ng/mL can be observed within brief intervals of time.<sup>410</sup> **A midluteal serum progesterone concentration cannot define the quality of luteal function and has little value beyond documenting ovulation.**

# Urinary LH Excretion

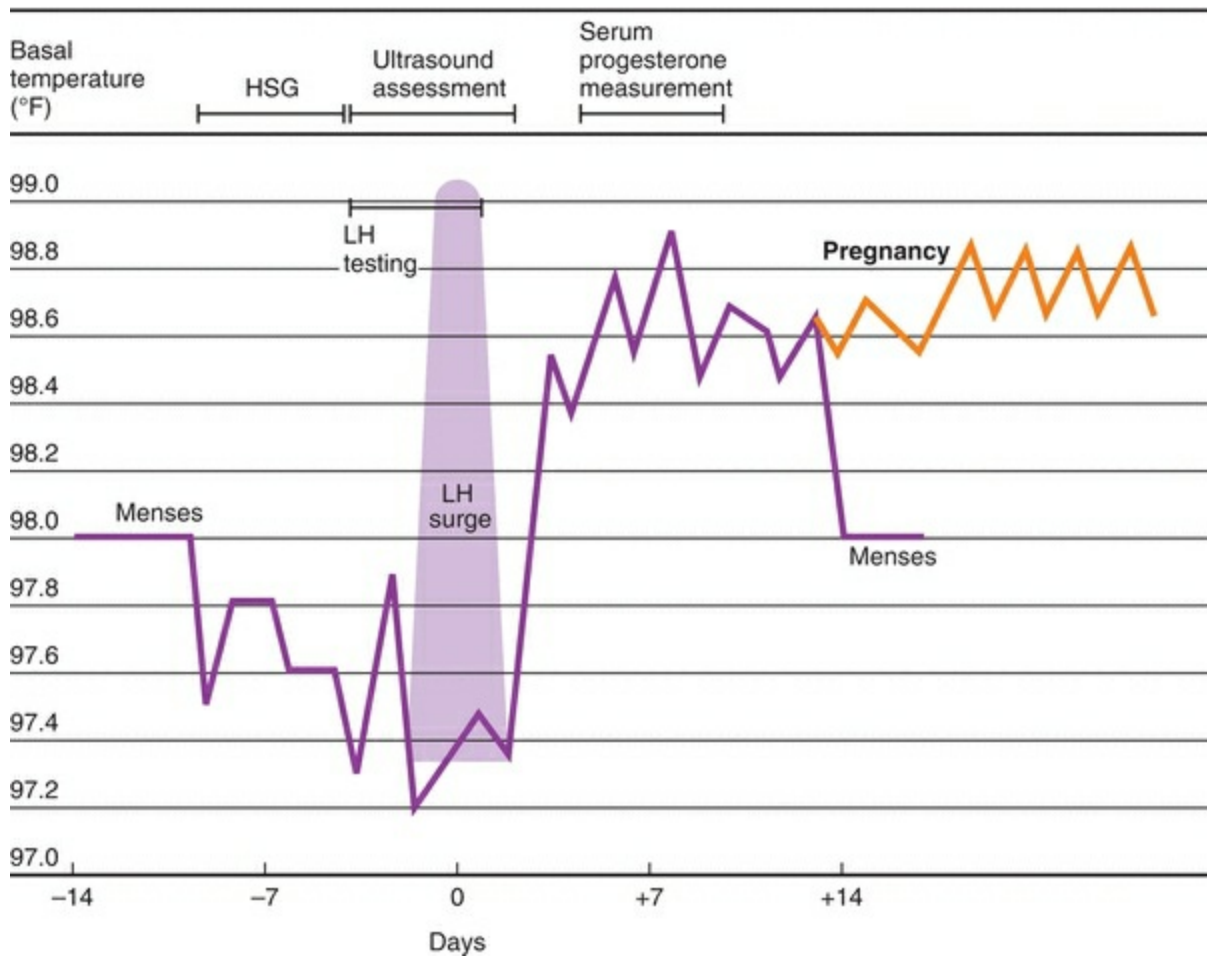
A wide variety of different commercial products allow women to determine not only if they ovulate, but when, in advance of the actual event. Generally known as “ovulation prediction kits” or “LH kits,” the products are all designed to detect the midcycle LH surge in urine.

The midcycle LH surge is a relatively brief event, typically lasting between 48 and 50 hours from start to finish. LH has a short half-life and is rapidly cleared via the urine. Ovulation predictor kits turn positive when the urinary LH concentration exceeds a threshold level normally seen only during the LH surge. In most cycles, the test is positive on a single day, occasionally on 2 consecutive days. To detect the LH surge reliably, testing must be done on a daily basis, generally beginning 2 or 3 days before the surge is expected, based on the overall length of the cycle. The first positive test provides all relevant information; there is no value in continued testing.

Test results are sensitive to both the volume of fluid intake and time of day. There is no need to restrict fluid intake, but patients should be advised to avoid drinking large volumes of fluid a short time before they plan to test. Logically, the first morning void would seem an ideal specimen to test because it is usually the most concentrated. However, results correlate best with the serum LH peak when testing is performed in the late afternoon or early evening hours (4:00–10:00 P.M.),<sup>396</sup> probably because LH surges often begin in the early morning hours and are not detected in urine for several hours. Twice-daily testing decreases the frequency of false-negative results (failure to detect the LH surge in an ovulatory cycle), but generally is unnecessary. When performed daily and properly timed, testing will detect the LH surge in most ovulatory cycles. True false-positive tests (detection of an LH surge in an anovulatory cycle) occur in approximately 7% of cycles<sup>411</sup>; equivocal or “borderline” results also are common and can be both confusing and frustrating.

The accuracy of ovulation predictor kits varies. All are useful and reasonably reliable, but some are better and easier to use than others.<sup>373,412,413</sup> The best products predict ovulation within the subsequent 24–48 hours, with greater than 90% probability.<sup>372,373</sup> **Ovulation generally occurs 14–26 hours after detection of the LH surge and almost always within 48 hours.**<sup>372</sup> **Consequently, the interval of greatest fertility includes the day the surge is detected and the following 2 days. The day after the first positive test generally is the one best day for timed intercourse or insemination.**<sup>372,414,415</sup> Ovulation predictor kits are noninvasive, are widely available, require relatively little time and effort, and invite women to become actively involved in their care without increasing their stress levels.<sup>416,417</sup> Their greatest advantage over other methods is their ability to predict when ovulation will occur. Accurate

identification of the midcycle LH surge also defines the length of the follicular and luteal phases, which may reveal subtle and otherwise unrecognized cycle abnormalities warranting treatment. Women who cannot detect an LH surge using the ovulation predictor kits are often anovulatory, but may assume the kit is not functioning properly; patients should be advised that failure to detect an LH surge may reveal an important diagnostic component of their infertility. After establishing ovulation, repeated urinary LH monitoring is perhaps best reserved for women who ovulate (based on menstrual history, LH monitoring, or an appropriately timed serum progesterone concentration), but have infrequent intercourse or require insemination (**Figure 25.4**).



**FIGURE 25.4**



# Endometrial Biopsy and Luteal Phase Deficiency

Endometrial biopsy can be used as a test of ovulation, based on the characteristic histologic changes induced by progesterone. During the follicular phase of the cycle, the endometrium exhibits a proliferative pattern, reflecting the growth stimulated by rising levels of estrogen derived primarily from the dominant ovarian follicle. During the luteal phase, progesterone secreted by the corpus luteum induces the “secretory” transformation of the endometrium. Anovulatory women are always in the follicular phase; their endometrium is always proliferative and even may become hyperplastic with extended exposure to a constant estrogen growth stimulus. **In the absence of treatment with exogenous progesterone or a synthetic progestin, a secretory endometrium implies recent ovulation.**

Endometrial biopsy is a relatively simple office procedure, usually performed with a disposable plastic aspiration cannula, and complications are few. Pretreatment with a nonsteroidal anti-inflammatory drug (NSAID) helps to reduce pain or cramping associated with the procedure. Sedation or anesthetic (paracervical block) is helpful when the biopsy is technically difficult and in women who are very anxious. When properly timed, in the same way and for the same reasons as a serum progesterone concentration, endometrial biopsy is an effective test of ovulation. However, it is also invasive, uncomfortable, and costly and provides little more information than can be obtained from BBT recordings, a serum progesterone concentration, or monitoring urine LH excretion. Therefore, endometrial biopsy has rather limited and specific indications in the evaluation of infertile women. For women with chronic anovulation of long duration, biopsy can identify or exclude endometrial hyperplasia that requires specific treatment. In those few individuals suspected of harboring a chronic endometritis, biopsy is diagnostic. **In the past, endometrial biopsy for diagnosis of luteal phase deficiency was considered a basic element of the infertility evaluation, but no longer.**

Inadequate corpus luteum progesterone production or “luteal phase deficiency” (LPD) was long considered an important cause of both infertility and early pregnancy loss.<sup>418,419</sup> The proposed mechanisms were different but related, representing only different points on a pathophysiologic continuum. In theory, because the human implantation window is relatively narrow (spanning the interval from approximately 6 to 10 days after ovulation),<sup>420,421,422</sup> low circulating progesterone levels could be expected to result in delayed endometrial maturation, causing a shift in the implantation window and failed or late implantation. A long delay would threaten embryo viability or prevent implantation. A shorter delay would allow implantation but result in a tardy or low-amplitude hCG rescue signal that could not stimulate normal amounts of progesterone from an already regressing corpus luteum, or maintain production for the

requisite duration,<sup>423,424,425</sup> with either causing a premature luteal-placental shift and pregnancy loss.<sup>426</sup> In this context, endometrial biopsy was viewed as a bioassay of luteal function because it would reflect both the functional capacity of the corpus luteum and the end-organ response.

The classic histologic features of secretory endometrial development were described by Noyes, Hertig, and Rock, in the lead article of the inaugural issue of **Fertility and Sterility**.<sup>427</sup> The pattern was considered sufficiently predictable to allow experienced pathologists to “date” the endometrium, assigning a histologic day that could be compared to the actual day of sampling, estimated by counting backward from the onset of the next menstrual period (assuming menses began on the 14th postovulatory day), or defined by the number of days elapsed since detection of the LH surge or observation of follicular collapse by serial ultrasonography.<sup>428</sup> Historically, histologic and sampling dates that agreed, within a 2-day interval, were considered normal, whereas a date more than 2 days “out of phase” was the gold standard criterion for the diagnosis of LPD.<sup>429,430,431</sup> Traditionally, diagnosis of LPD required abnormal results in two (preferably consecutive) cycles, reasoning that reproductive failure could only be attributed to LPD if it was consistent or recurring and acknowledging that LPD also could occur in normal fertile women, at least occasionally.<sup>432,433,434,435,436,437,438</sup> Endometrial dating was accepted widely by clinicians and pathologists and the practice endured, despite numerous challenges to its validity.

The first and most fundamental criticism of the traditional histologic dating criteria was that the normal standard was based on analysis of tissue specimens obtained from infertile women<sup>427</sup>; the reference population was abnormal, by definition, and also likely heterogeneous because infertility has many different causes. Second, the sampling date was estimated retrospectively, after the onset of menses, assuming a uniform 14-day luteal phase, despite numerous studies demonstrating that luteal phase duration varied significantly, even in normal women.<sup>103,108,111,439,440</sup> Moreover, retrospective estimates of the sampling date correlated poorly with the time of ovulation as defined by the LH surge or observations of follicular collapse,<sup>407,428,441</sup> and ignored any effect that biopsy might have on the onset of menses, or when it was perceived to start.<sup>428,437,442</sup> Third, the traditional histologic dating criteria were inherently subjective, and numerous studies had observed significant intraobserver and interobserver variations in histologic interpretation that were great enough to affect diagnosis and management in 20–40% of individual women.<sup>431,443,444,445,446</sup>

The standard practice of endometrial biopsy and histologic dating for diagnosis of LPD was proven invalid in 2004, for all intents and purposes. A systematic reanalysis of the histologic features used for endometrial dating confirmed the classically

described sequence, but revealed the patterns were much less temporally discrete than originally described, and demonstrated that normal variations among individuals, between cycles in individuals, and among different observers were too great to reliably define any specific luteal day or even a narrow interval of days.<sup>447</sup> Soon thereafter, a large multicenter trial demonstrated conclusively that abnormal histologic dating could not discriminate infertile from proven fertile women.<sup>448</sup> The second study invalidated the practice of endometrial dating, and the first explained why the method failed.

Recent evidence challenges even the basic premise on which the concept of LPD is founded: that abnormally low circulating progesterone concentrations result in delayed endometrial maturation. In normal women treated with a fixed physiologic dose of estrogen after downregulation with a GnRH agonist, and then randomized to receive physiologic (mean progesterone level 19 ng/mL) or grossly low levels of exogenous progesterone treatment (mean progesterone level 5.5 ng/mL), there was no discernible difference in endometrial histology.<sup>449</sup> These observations suggest the histologic features of secretory endometrium relate more to the duration of progesterone exposure than to the concentration. Studies using a similar design have demonstrated that widely ranging concentrations of estradiol also have no discernible impact on secretory endometrial maturation.<sup>450</sup> Altogether, these data indicate that secretory endometrial development can progress normally despite widely varying concentrations of estradiol and progesterone, challenging the traditional paradigm, and served to further invalidate the use of endometrial histologic dating as a diagnostic tool. **In sum, histologic endometrial dating cannot guide the clinical management of women with reproductive failure and has no place in the diagnostic evaluation of infertility.**

The lack of any valid method for diagnosis of LPD does not refute its existence or its potential importance in the pathophysiology of reproductive failure. The pathogenic mechanisms outlined above are still viable. Evidence supports the notion of a finite implantation window<sup>420,421,422</sup> that progesterone is essential for embryo implantation<sup>451</sup> and that delayed implantation might adversely affect corpus luteum function,<sup>423,424,425</sup> predisposing to reproductive failure.<sup>426</sup> It is entirely possible, if not likely, that abnormally low levels of progesterone might have important functional consequences with no morphologic correlate. Biochemical or molecular markers of endometrial function provide the means to further explore the possibility. The pattern of endometrial gene expression defines distinct functional phases of the cycle.<sup>452</sup> A number of endometrial proteins exhibit patterns of expression or gene regulation during the putative implantation window, suggesting they might serve as markers of endometrial receptivity, including cytokines (leukemia inhibitory factor, colony-stimulating factor-1, and interleukin-1), cell adhesion molecules (the avb3 integrin), transcription factors (HOXA10 and HOXA11),<sup>453,454,455,456</sup> glycodelin, and the polymorphic mucin 1,<sup>457,458</sup>

osteopontin,<sup>459,460,461</sup> N-acetylglucosamine-6-O-sulfotransferase (important in the synthesis of L-selectin ligands),<sup>462</sup> and the L-selectin ligand itself.<sup>463</sup>

Analysis of the transcriptomic signature of 134 genes in endometrial biopsies revealed high specificity for endometrial dating and has been applied clinically to improve pregnancy success in women with recurrent implantation failure in assisted reproduction, by increasing likelihood of transfer during the window of implantation.<sup>464,465</sup> However, it is unlikely that all recurrent implantation failures would be due to asynchronous endometrial response to progesterone, and more recently, another study reported a transcriptomic signature involving 303 genes in women who have failed multiple IVF treatment cycles.<sup>466</sup> Genes involved in cell cycle regulation and cell division, general proliferative processes, and cytoskeleton and cilia formation were found to be downregulated in the endometrium transcriptome of women with multiple IVF failures, suggesting a more disrupted rather than an asynchronous pattern.<sup>466</sup>

None of these findings has been adequately validated as a reliable measure of endometrial function or receptivity, but if and when that occurs, a functional marker may become the basis for diagnosis of LPD, and endometrial biopsy again may be viewed as offering valuable information beyond that provided by other tests of ovulation.

# Transvaginal Ultrasonography

The last and most complicated test of ovulation involves serial TVUS, which permits direct observation of events in the ovary just before and immediately after ovum release. Although still not providing positive proof that ovulation actually occurred, serial TVUS provides detailed information about the size and number of preovulatory follicles and the most accurate estimate of when ovulation occurs.

In its final stages of development, the preovulatory follicle grows at a predictable pace, approximately 2 mm per day (range: 1–3 mm/day). After ovulation, the follicle collapses, margins become less distinct, the density of internal echoes increases, and the volume of cul-de-sac fluid increases.<sup>467,468</sup> Abnormal patterns of follicle development also can be observed. The follicle may grow at an abnormal pace, collapse when still relatively small, or continue to grow but fail to rupture and persist as a cyst for days after the LH surge—the luteinized unruptured follicle.<sup>469,470</sup> Such subtle forms of ovulatory dysfunction cannot be detected otherwise, but also are rare. **Because treatment with prostaglandin synthase inhibitors (NSAIDs) can disrupt the ovulatory process and predispose to a luteinized unruptured follicle,<sup>471,472</sup> their use is best limited to the menstrual phase of the cycle in women attempting to conceive.**

Serial TVUS to monitor the size and number of developing follicles is essential to the safety and effectiveness of ovulation induction with exogenous gonadotropins ([Chapter 27](#)), but the costs and logistical demands involved are otherwise difficult to justify. Consequently, the method generally should be reserved for the few in whom the safety or effectiveness of treatment truly hinges on the detailed information it offers.

## Summary: Assessment of Ovulation

The evaluation of ovulation is a core component of the evaluation for infertility. All of the different methods are useful and no one method is necessarily best. Whereas some are very simple, noninvasive, and inexpensive, others are more complicated, invasive, and costly. A few provide the means to determine not only if ovulation occurs, but when, with varying accuracy. The best choice among methods varies with the information required. In women with oligomenorrhea or amenorrhea, no formal evaluation is needed to establish a diagnosis of ovulatory dysfunction, but endometrial biopsy to exclude hyperplasia may be prudent, depending on duration. When the only objective is to confirm ovulatory function, as in those with regular monthly menses, a properly timed serum progesterone concentration is the simplest and most reliable method. When circumstances require accurate prediction of ovulation, as in couples having infrequent intercourse or those requiring insemination, urinary LH monitoring generally is the most cost-effective and appropriate choice. In the few who require insemination but consistently fail to detect a midcycle LH surge, serial TVUS can provide the necessary information; however, an ovulatory defect should be suspected. Ultimately, the method chosen should be tailored to the needs of the individual patient.

Infertile women with ovulatory dysfunction are obvious candidates for ovulation induction. In general, only limited additional evaluation is needed to define the initial treatment of choice, and most women will respond promptly to one of the simpler treatment strategies ([Chapter 27](#)). In the majority of cases, it is reasonable and appropriate to begin treatment immediately, even before other potential causes of infertility have been investigated. If anovulation is the only obstacle to overcome, most couples will conceive promptly without further interventions. Women with amenorrhea or hyperandrogenic anovulation deserve additional preliminary evaluation, applying the principles described in [Chapters 10, 11, and 12](#).

# CERVICAL FACTOR: ABNORMALITIES OF SPERM-MUCUS INTERACTION

---

The cervix participates in the reproductive process in several ways. Cervical mucus accepts or captures sperm from the ejaculate and the vagina, excludes the seminal plasma and morphologically abnormal sperm,<sup>473</sup> nurtures sperm biochemically, and serves as a reservoir, thereby prolonging sperm survival and the fertile interval between intercourse and ovulation. Mucus is a glycoprotein gel with solid and liquid phases and has a mosaic ultrastructure with interstitial channels between mucin strands that expand and contract in response to cyclic changes in the steroid hormone environment across the menstrual cycle to facilitate or inhibit the passage of sperm.<sup>474,475,476,477,478</sup> Estrogen stimulates cervical mucus production, and as levels rise during the follicular phase, mucus becomes more abundant and watery, less cellular, and more easily penetrated by sperm.<sup>479</sup> Progesterone inhibits cervical mucus production and renders it opaque, viscid, and impenetrable. The cyclic changes in cervical mucus characteristics help to explain why the cycle day-specific probability of conception rises steadily as ovulation nears and plummets immediately thereafter.

For most of the past century, the postcoital test for diagnosis of cervical factor infertility was considered a basic element of the infertility evaluation. The test involved collection of cervical mucus (by aspiration or with nasal polyp forceps) shortly before the expected time of ovulation (as determined by BBT or urinary LH monitoring in previous cycles) a few to several hours (typically 2–12 hours) after intercourse.<sup>480</sup> The mucus specimen was evaluated for pH, clarity, cellularity, viscosity (the length to which a column of mucus can be stretched in centimeters, known as “spinnbarkeit”), and salinity (evaluated according to the complexity of the network of crystals that forms when mucus is dried on a glass slide, also known as “ferning”) and for the number and motility of surviving sperm. The presence of motile sperm confirmed effective coital technique and sperm survival, and the number of sperm (per high-power field) was used to predict semen quality (sperm density and motility) and cycle fecundability (inverse correlation with time to conception or cumulative conception rates).<sup>481,482,483,484,485,486</sup> Most considered even a single motile sperm in most fields a normal test result.<sup>486,487,488</sup>

Abnormal postcoital test results were common, usually due to improper timing, either too early in the cycle when mucus was relatively scant or after ovulation when mucus quality was poor.<sup>489</sup> Timing was optimized by performing the test within 2 days before the LH surge or when TVUS demonstrated a preovulatory follicle.<sup>490</sup> Other explanations for poor-quality mucus were cervicitis, previous treatment for cervical intraepithelial neoplasia (e.g., cryotherapy), and treatment with clomiphene citrate.

Potential explanations for the absence of motile sperm in good-quality mucus included ineffective intercourse, failed ejaculation (frequently resulting from performance anxiety), poor semen quality, and use of spermicidal coital lubricants. Observations of degenerating, immotile, “shaking,” or agglutinated sperm were considered reason for antisperm antibody testing.<sup>484</sup> An abnormal result was confirmed by repeat testing to establish the diagnosis of cervical factor infertility,<sup>480,486,491</sup> prompting further evaluation with a nucleic acid test for chlamydia and cultures for ureaplasma and mycoplasma (or empirical treatment with antibiotics),<sup>492,493,494</sup> and semen analysis. Normal semen quality and absence of sperm in good-quality mucus were regarded as evidence of “hostile” cervical mucus or a sperm function abnormality, differentiated by comparisons of partner and donor sperm survival and motility in bovine cervical mucus in vitro and antisperm antibody testing.<sup>495,496,497</sup> Strategies for correcting or overcoming cervical factor infertility included treatment with exogenous estrogens (to stimulate mucus production)<sup>498</sup> or mucolytic agents (guaifenesin),<sup>499</sup> precoital douching with a sodium bicarbonate solution,<sup>500</sup> and IUI.<sup>484,501,502,503</sup>

Advocates of routine postcoital testing argued that the postcoital test could identify couples who might benefit from a simple treatment and had prognostic value for predicting the probability of pregnancy without treatment.<sup>382,485</sup> Critics reasoned that results achieved even with IUI suggested only a modest benefit at best,<sup>504</sup> that any prognostic value the test might have was limited to young couples with unexplained infertility of short duration because the test surely had no predictive value in women with infertility due to anovulation or tubal occlusive disease, and that male infertility amenable to treatment with IUI could be more accurately defined by the results of semen analysis. The argument for expectant management in couples with unexplained infertility and a normal postcoital test was dismissed as moot, because few couples seeking evaluation and treatment accepted the recommendation.

**The postcoital test for diagnosis of cervical factor is no longer recommended.**<sup>384</sup> Abnormalities of cervical mucus production or sperm/mucus interaction are rarely, if ever, the sole or principal cause of infertility. Chronic cervicitis or cervical stenosis resulting from conization or other treatment for cervical disease that might impair sperm-mucus interaction can be identified by speculum examination, and in the absence of such findings, the likelihood that cervical mucus represents an important obstacle is remote. Semen analysis identifies couples with significant male factor infertility. The test has no standard methodology or interpretation<sup>480,488</sup> and has poor reproducibility even among trained observers.<sup>505</sup> The only randomized trial comparing outcomes in women with normal and abnormal postcoital tests found the test invalid because neither test results nor treatment for abnormal tests affected the outcome.<sup>506,507,508</sup> Office examination after scheduled



intercourse is an inconvenient and unwelcome intrusion for most couples, adding further to their burden of stress. Finally, postcoital test results seldom change clinical management, because contemporary treatments for unexplained infertility include IUI (with ovarian stimulation) or IVF, both of which negate any contributing cervical factor.

# UTERINE FACTOR: ANATOMIC AND FUNCTIONAL ABNORMALITIES

---

Abnormalities of the uterus are a relatively uncommon cause of infertility, but should always be considered. If for no other reason, they may adversely affect the outcome of pregnancies achieved by successful treatment of more common male, ovarian, and tubal factors. The anatomic uterine abnormalities that can adversely affect fertility include congenital malformations, leiomyomas, and intrauterine adhesions; endometrial polyps also have been implicated, but their reproductive implications are less clear. The only functional uterine abnormality of specific interest in the evaluation of infertility is chronic endometritis. Whereas abnormalities of endometrial receptivity (including LPD) might be viewed as another, they can have no practical significance until there is conclusive evidence that infertility can result from intrinsic endometrial dysfunction that impairs or prevents implantation and a method for diagnosis has been validated.

Anatomic and functional uterine abnormalities that can impair fertility also can adversely affect pregnancy outcome. They are discussed here as a cause of infertility and elsewhere ([Chapter 30](#)) as a cause of recurrent pregnancy loss. The embryology or pathogenesis and obstetric consequences of uterine malformations and of leiomyomas are considered at length in [Chapter 3](#). Discussion here is focused on their diagnosis, their impact on fertility, and how they influence evaluation and treatment.

There are three basic methods for evaluation of the uterine cavity: HSG, TVUS or saline sonohysterography, and hysteroscopy. Each has advantages and disadvantages and the choice among them should be tailored to the needs of the individual patient. HSG is the traditional method and most often still the best initial test because it also evaluates tubal patency. However, in women with no risk factors for tubal disease and those whose tubal status is already known (from earlier surgery for other indications) or is largely irrelevant (as in women who require IVF for severe male factor infertility), ultrasonography offers a simpler and better tolerated alternative that also may reveal unsuspected ovarian pathology (cyst, endometrioma), with no radiation exposure. When symptoms suggest an anatomic lesion of the uterine cavity (menorrhagia, intermenstrual spotting), sonohysterography is the most sensitive and logical diagnostic test. Hysteroscopy is definitive but has few diagnostic advantages over sonohysterography and generally can be safely reserved for treatment of abnormalities already identified by less invasive and costly methods.

# Hysterosalpingography

HSG accurately defines the size and shape of the uterine cavity, provides clear images of most uterine developmental anomalies (unicornuate, septate, bicornuate, and didelphys), and, with exceptions, also identifies submucous myomas and intrauterine adhesions that can have important reproductive implications. Although HSG also may reveal endometrial polyps, sonohysterography is a more sensitive method for their detection. A slow injection of contrast medium helps to minimize the risk that a cavity lesion will be obscured and go undetected.

The normal uterine cavity is symmetrical, roughly triangular in shape, widest at the level of the cornual orifices near the fundus, and relatively smooth in its contours. The various developmental uterine anomalies generally have a fairly characteristic appearance on HSG. A unicornuate uterus is typically somewhat tubular, deviates to the left or right, and has one fallopian tube. Both septate and bicornuate uteri typically exhibit a common lower segment that divides into two distinct horns to yield a Y-shaped configuration with varying distance between the upper arms.<sup>509,510</sup> The two anomalies cannot be differentiated by HSG alone; additional evaluation is required to establish an accurate diagnosis (standard or three-dimensional ultrasonography, sonohysterography, magnetic resonance imaging [MRI], or laparoscopy).<sup>511</sup> Either anomaly also can be confused with a unicornuate uterus if only one of the two horns is imaged because they divide near or below the tip of the cannula or catheter inserted into the cervix or uterus. To properly study a uterus didelphys or complete septate uterus, the two hemiuteri must be imaged via their separate cervical openings, often found on opposite sides of the two hemivaginas of varying length. Myomas and larger polyps generally produce curvilinear filling defects of various sizes and shapes. HSG in women with intrauterine adhesions usually reveals grossly irregular cavity contours and filling defects and, in many with severe disease, no cavity at all.

The accuracy of HSG for detecting intrauterine pathology in infertile women varies with the nature of the abnormality. A large study involving over 300 women comparing HSG to hysteroscopy (the gold standard) observed that HSG had an overall 98% sensitivity, 35% specificity, 70% PPV, and 92% NPV, with a 30% false-positive rate and 8% false-negative rate; misdiagnoses are almost entirely related to distinguishing submucous myomas from polyps and were, therefore, relatively unimportant<sup>512</sup>; either requires surgical intervention for correction. In another study of similar design, HSG had 75% sensitivity for detection of intrauterine adhesions and only 50% sensitivity for detection of endometrial polyps.<sup>513</sup>

Specific issues concerning the scheduling and preparation for HSG and details regarding technique and interpretation as they relate to the evaluation of tubal factor

infertility are addressed in the following section (see “Tubal Factor,” below).

# Transvaginal Ultrasonography and Saline Sonohysterography

TVUS is another method for evaluation of uterine factors in infertile women. Saline sonohysterography, involving TVUS during or after introduction of sterile saline through a catheter designed for the purpose, crisply defines cavity contours and readily demonstrates even small, but potentially important, intrauterine lesions.<sup>514</sup>

In all phases of the cycle, the interface between the endometrium and the myometrium is well defined. The interface between the two layers of the endometrium itself (bordering the uterine cavity) can be difficult to identify very early in the cycle and during the secretory phase, but is visible during the latter half of the proliferative phase. Together, the two layers of the endometrium comprise the “endometrial stripe,” which changes in appearance and thickness across the cycle. During the proliferative phase, the endometrium is relatively hypoechoic and grows in thickness to yield a prominent “triple line” or trilaminar pattern. During the secretory phase, the endometrium grows little more, or not at all, and increases in echodensity, possibly because the developing network of coiled basilar vessels presents a great many more reflective surfaces. Cycle-dependent changes in uterine artery blood flow parameters (velocity and pulsatility index) measured using color and pulsed Doppler ultrasonography also have been described,<sup>515,516</sup> but diurnal variations and differences between the two uterine arteries (ipsilateral or contralateral to the dominant ovarian follicle) complicate interpretation. In efforts to define a receptive endometrium, several studies have examined the correlation between endometrial stripe thickness and pattern or uterine artery blood flow parameters with implantation or pregnancy rates in IVF cycles,<sup>517,518,519,520,521,522</sup> but results are conflicting. Whereas some have found correlations between one or more parameters and treatment outcomes, others have not. The few studies examining the endometrium in unstimulated cycles in infertile women have not demonstrated any important correlation between endometrial thickness, pattern, or blood flow and the cause of infertility or prognosis.<sup>523,524,525</sup> **In the diagnostic evaluation of infertile women, transvaginal ultrasonography can identify important uterine pathology but provides no useful measure of endometrial function or receptivity.**

For identification of congenital malformations, standard two-dimensional TVUS complements HSG and improves diagnostic accuracy for differentiating septate and bicornuate uteri by revealing the shape of the fundal contour. The septate uterus presents a single unified fundus that often is somewhat broader than normal and sometimes slightly concave; the bicornuate uterus has two entirely separate fundi divided by a distinct midline cleft of varying depth.<sup>509,511</sup> The accuracy of saline sonohysterography

exceeds that of HSG, by revealing both the double uterine cavity and the shape of the fundal contour. Three-dimensional (3D) ultrasonography has the advantage of obtaining a coronal view and providing accurate and reproducible information about external and internal contours of the uterus, ideally when the endometrium is 5 mm or thicker.<sup>510,511,526,527</sup> Three-dimensional ultrasonography showed 100% specificity and sensitivity for diagnosing congenital uterine anomalies in two studies, and its concordance with specificity and sensitivity of laparoscopy and hysteroscopy was reported to be 100% and 96%, respectively.<sup>528,529</sup> Another study reported 87% sensitivity and 97% specificity for 3D ultrasonography after evaluating 214 women with infertility who underwent laparoscopy and hysteroscopy.<sup>530</sup>

Results of studies evaluating the accuracy of TVUS for detection of submucous myomas and endometrial polyps have varied, but in general, both two-dimensional and 3D TVUS are more sensitive than HSG and approach the accuracy of hysteroscopy.<sup>531,532,533,534</sup> In a study of 3,850 infertile women with 74 histologically diagnosed endometrial polyps, 3D TVUS had sensitivity, specificity, PPV, and NPV of 100%, 99.7%, 98.6%, and 100%, respectively.<sup>535</sup> Other studies yielded similar results for the diagnostic accuracy of 3D ultrasonography, comparable to that of hysteroscopy.<sup>531,536</sup> Three-dimensional ultrasonography can successfully illustrate the endometrial cavity and map the location of the fibroids, even when they are multiple.<sup>535</sup> Yet, it should be kept in mind that MRI may produce more accurate results than 3D ultrasonography (USG) in some extreme cases. Accuracy for diagnosing fibroids dropped from 98% to 89% for 3D ultrasonography and from 100% to 94% for MRI, when five or more fibroids were present.<sup>537</sup> It is noteworthy that whereas the detection of an overall or focal increase in endometrial thickness or asymmetry between the two layers in two-dimensional or 3D TVUS suggests a polyp or myoma, saline sonohysterography reveals a polypoid projection into the fluid-filled cavity.

For diagnosis of intrauterine adhesions, standard TVUS is reasonably specific, but rather insensitive<sup>513,538</sup>; a focally narrowed or discontinuous endometrial stripe suggests the diagnosis. Saline sonohysterography compares with HSG, having relatively high sensitivity (75%) and specificity (over 90%), modest PPV (approximately 50%), and excellent NPV (over 95%) for detection of adhesions.<sup>513,539</sup> Women with mild disease exhibit mobile thin, echogenic bands bridging a normally distensible endometrial cavity. Those with severe disease have more broadly based bands or no cavity at all.<sup>540</sup>

# Hysteroscopy

Hysteroscopy is the gold standard method for both diagnosis and treatment of intrauterine pathology that may adversely affect fertility. Traditionally, hysteroscopy was reserved for treatment of disease identified by other less invasive methods, but modern operative hysteroscopes with an outer diameter measuring 2–3 mm now permit diagnostic and minor operative procedures to be performed safely in the office setting.<sup>541</sup> Major intrauterine pathology generally requires more traditional operative hysteroscopy using instruments having larger caliber and greater capabilities.

# Congenital Uterine Anomalies

**Developmental uterine anomalies have long been associated with pregnancy loss and obstetric complications, but affected women generally are not infertile.** The prevalence of uterine anomalies in infertile women and fertile women with normal reproductive outcomes is similar, approximately 2–4%.<sup>542,543,544,545,546,547</sup> The prevalence is higher among women with poor pregnancy outcomes, such as miscarriage (13%), and in those with a history of infertility and recurrent miscarriage (24.5%).<sup>548</sup> Consequently, when discovered during an infertility evaluation, anomalies cannot be regarded as the likely cause or even as an important contributing cause of infertility, but only as another obstacle that must be considered when planning treatment after evaluation is completed. For example, treatments associated with substantial risk for multifetal gestation (ovarian stimulation/IUI, IVF) present even greater risks to women with uterine malformations.

In a recent systematic review, septate uterus was the most common anomaly among infertile women (3%), followed by arcuate (2%), bicornuate (1.1%), unicornuate (0.5%), and didelphys (0.3%).<sup>547,548</sup> However, arcuate uterus is considered as a variant of the normal without any reproductive or obstetric consequences.<sup>549</sup> The prevalence of only unicornuate and bicornuate uteri was found to be significantly higher in infertile women than in unselected population of women.<sup>548</sup>

Septate uterus is the anomaly most highly associated with reproductive failure and obstetrical complications, including first- and second-trimester miscarriage, preterm delivery, fetal malpresentation, intrauterine growth restriction, and infertility.<sup>511,547,550</sup> The mechanisms responsible are poorly understood, but poor septal blood supply, resulting in poor implantation efficiency and embryo growth, and cervical incompetence are the usual suspects.<sup>551,552,553,554</sup>

Although diagnosis of septate uterus is not an automatic indication for metroplasty, the overall reproductive performance of women with a septum in situ (at least those who are recognized) is rather poor, with term delivery rates of approximately 40%. Most losses occur in the first trimester (approximately 60%). A methodologically robust meta-analysis of 19 studies assessing the effect of septum incision in a mixed population of women with infertility, miscarriage, and/or recurrent pregnancy loss found an overall pregnancy rate of 64% and live birth rate of 50% after septum incision.<sup>555</sup> In the past, surgical correction of a septate uterus required abdominal metroplasty, risking postoperative adhesions that might impair fertility, and committed all future successful pregnancies to cesarean birth. Surgical treatment was reserved for women in whom the benefits of surgery more clearly outweighed the risks, but modern hysteroscopic surgery has changed the equation. Today, hysteroscopic septum resection is a relatively



straightforward and brief outpatient procedure associated with low morbidity, no risk of adnexal adhesions or obligation to cesarean delivery, and a prompt and uneventful recovery; surgical indications now are appropriately more liberal.

Inevitably, systematic infertility evaluations will identify nulligravid women with a uterine septum who present a management dilemma. Given the high probability of successful hysteroscopic surgery and its low morbidity, we believe it is reasonable and appropriate to consider pre-emptive surgical correction of a septate uterus, especially in women over age 35, women with infertility of long duration, women with other indications for surgical treatment, and women who require IVF or other treatments associated with increased risk of multifetal gestation and pregnancy loss.<sup>511,547,549,556</sup> Careful discussion of the relative risks and benefits of surgery is always important, but especially so when the indications for surgery are less clear.

# Uterine Myomas

Myomas can be identified up to 70% of all reproductive-aged women and in 5–10% of infertile women<sup>557,558</sup>; myomas are the only abnormal finding in 1–2% of women with infertility. Although they are an established cause of abnormal bleeding, pain, and symptoms relating to pressure on adjacent organs, the impact of myomas on fertility has been more difficult to define, with the bulk of evidence coming from observational studies comparing the prevalence of myomas in fertile and infertile women or the reproductive performance of women with otherwise unexplained infertility before and after myomectomy.<sup>182,183</sup> Most studies are methodologically limited, such as small heterogeneous populations, with inconsistent definitions of myomas with regard to their size, location, and number, and often failing to report relevant outcome measures.<sup>559</sup> **Infertility relating to myomas has been attributed to all of the following mechanisms<sup>560</sup>:**

- **Displacement of the cervix, decreasing exposure to sperm**
- **Enlargement or deformity of the uterine cavity, interfering with sperm transport**
- **Obstruction of the interstitial segment of the fallopian tubes**
- **Distorted adnexal anatomy, interfering with ovum capture**
- **Distortion of the uterine cavity or increased or abnormal myometrial contractions, inhibiting sperm or embryo transport**
- **Impaired uterine blood flow, chronic endometritis, or decreased endometrial receptivity, interfering with implantation**

Whereas there is relatively little evidence to support the majority of these mechanisms, a number of observations lend credence to the notion that myomas may impair fertility by interfering with implantation. Glandular atrophy is commonly observed in the endometrium overlying myomas, depending on their proximity, and also can be seen in the opposing endometrium, suggesting it results from mechanical pressure.<sup>561,562,563</sup> Molecular studies indicate that submucous and intramural myomas may induce a local decrease in HOX gene expression, which has been implicated in the cascade of molecular events involved in implantation.<sup>564,565</sup>

The effects of myomas on fertility are best assessed by studies comparing IVF outcomes in infertile women with and without myomas, because IVF effectively controls for the confounding effects of other fertility factors. Numerous studies have examined the effects of myomas of varying size and location.<sup>566,567,568,569,570,571,572</sup> Altogether, these observations permit some conclusions regarding the effects of myomas on IVF

outcomes and, by inference, on overall fertility.

There is a clear consensus that submucous myomas have significant adverse effect on clinical pregnancy rates (OR = 0.3, CI = 0.1–0.7) and delivery rates (OR = 0.3, CI = 0.1–0.8).<sup>183,560,573,574,575,576,577</sup> Available data also support the conclusion that submucous myomas increase risk for miscarriage by more than threefold,<sup>576,577</sup> while the effect of intramural myomas that do not distort the cavity on the risk of miscarriage is less clear.<sup>578</sup> Results of early studies examining the effect of intramural myomas on IVF outcomes were inconsistent, with some finding adverse effects,<sup>567,568,569,570,579</sup> and others not.<sup>566,576,580,581,582,583,584</sup> Large-scale prospective studies report significantly lower implantation, pregnancy, ongoing pregnancy, and live birth rates.<sup>569,570</sup> A 2010 systematic review of the effect of intramural myomas without uterine cavity involvement on IVF outcome included 19 observational studies comprising 6,087 IVF cycles.<sup>585</sup> Live birth rate was significantly decreased (RR = 0.79, 95% CI = 0.70–0.88). It is noteworthy that when results from the only two prospective studies reporting live birth rate were pooled, the relative reduction in live birth was 40% (RR = 0.60, 95% CI = 0.41–0.87). Likewise, clinical pregnancy rate was decreased by 21% (RR = 0.79, 95% CI = 0.70–0.88), and implantation rate was decreased by a relative 13% (RR = 0.87, 95% CI = 0.73–1.03).<sup>585</sup> All of the evidence concerning the effects of subserosal myomas is consistent in finding no evidence of adverse effects on IVF outcomes. **In sum, the accumulated body of evidence indicates that submucous myomas reduce IVF success rates by approximately 70% and intramural myomas by approximately 20–40%, and subserosal myomas have no adverse impact on outcomes. Submucous myomas increase risk for miscarriage after successful IVF at least threefold and intramural myomas by more than half.**

Logically, decisions regarding the management of infertile women with myomas should be guided by the evidence concerning their likely importance and the outcomes of surgical intervention. It seems clear that submucous myomas (distorting the uterine cavity) have important adverse effects on fertility and pregnancy outcomes and that myomectomy improves both. A 2009 systematic review of studies examining outcomes after submucous myomectomy concluded that clinical pregnancy rates achieved with IVF were twofold higher after surgery than in women with submucous myomas in situ and comparable to those observed in women without myomas.<sup>577</sup> A randomized trial comparing the effects of myomectomy and expectant management on fertility in 181 women with a combination of submucous, intramural, and subserosal myomas observed that myomectomy significantly improved pregnancy rates among women with submucous myomas (43% vs. 27%) and those with both submucous and intramural myomas (26% vs. 15%), without other interventions.<sup>586</sup> Younger women having a single small submucous myoma and otherwise unexplained infertility have the best prognosis.

Results are less encouraging for older women and those with multiple or large submucous myomas. Although complications of hysteroscopic myomectomy are relatively few, the risk of postoperative intrauterine adhesions increases with the size, number, and extent of intramural extension of submucous myomas.

Evidence for the benefits of myomectomy in women with intramural myomas (not distorting the uterine cavity) is less compelling, probably because their impact on fertility is not as great. A randomized trial observed a clinically significant trend toward improved fertility in women with intramural myomas after myomectomy (56% vs. 41%).<sup>586</sup> A prospective, nonrandomized cohort study involved 318 women with recurrent pregnancy loss or unexplained infertility and compared women undergoing laparoscopic myomectomy, those with conservatively followed myomas, and a control group of unexplained infertility without myomas.<sup>587</sup> Women undergoing laparoscopic myomectomy had higher live birth rates compared to those with in situ myomas (42% [44/106] vs. 11% [12/106], respectively) and those with unexplained infertility without myomas (25% [27/106]). The observations were limited by differences in age between groups, and selection bias is a potential threat to the validity of nonrandomized studies, that is, women who underwent surgery could have different types of myomas than women who did not have surgery.

It is noteworthy that the single existing randomized controlled trial (RCT) found no significant effect of myomectomy on clinical pregnancy rates based on the type of fibroid removed (intramural, odds ratio [OR] 1.88, confidence interval [CI] 0.57–6.14, 45 women; submucosal, OR 2.04, CI 0.62–6.66, 52 women; intramural-subserosal, OR 2.0, CI 0.40–10.09, 31 women; intramural-submucosal, OR 3.24, CI 0.72–14.57, 42 women).<sup>586</sup> Similarly, a cohort study involved 63 infertile women with intramural myomas and 100 age-matched controls without myomas undergoing ART with the same stimulation protocol. Nineteen of the 63 women with myomas underwent myomectomy prior to ART.<sup>588</sup> Clinical pregnancy rates were similar between groups (36% myomectomy vs. 29% in situ intramural myoma vs. 36% controls). Similar results were found in a retrospective cohort study of 58 women undergoing ART with a history of prior myomectomy or myomas in situ.<sup>589</sup>

In contrast to these studies, a trial of 168 women with non-cavity-distorting intramural myomas compared ART outcomes between those who underwent laparoscopy before ART and no surgery prior to ART.<sup>590</sup> Cumulative pregnancy rate (34% [28/84] vs. 15% [13/84]) and live birth rate (25% [21/84] vs. 12% [10/84]) were significantly higher in the laparoscopy group compared with the nonsurgical group.<sup>590</sup> Benefit of myomectomy was observed in the surgical group of women who had at least one fibroid with a diameter greater than 5 cm. However, many of these studies are underpowered, and the inclusion/exclusion criteria of the size and location

of myomas in study subjects are inconsistent. Age differences between groups were not reported or taken into consideration during analyses; fibroid size and number between groups and potential selection bias limit the validity of these findings. Thus, these data do not clearly demonstrate an improvement or deterioration in outcomes after myomectomy compared with no surgery.

**Decisions regarding the management of infertile women with asymptomatic intramural myomas are among the most difficult clinical judgments. They must consider not only the size, number, and location of myomas and the risks and benefits of the procedure but also age, duration of infertility, ovarian reserve, other infertility factors, and the treatments they require.** In most cases, the benefits of myomectomy are modest or uncertain, and the procedure is not without significant potential risks. Myomectomy commonly results in postoperative pelvic and adnexal adhesions, which can decrease fertility if severe,<sup>591,592</sup> but are less concerning in women who require IVF for other reasons. Myomectomy generally commits the patient to cesarean delivery to avoid the risk of uterine rupture during labor, which has been reported after myomectomy.<sup>593,594,595,596</sup> Whereas excision of large, deep intramural myomas that abut or displace the uterine cavity might reasonably be expected to improve fertility, removal of smaller myomas having no direct anatomical relationship with the cavity probably will not. Whereas excision of anterior and fundal myomas is not likely to result in serious adnexal adhesions, posterior uterine incisions invite the complication. Arguably, excision of any intramural myomas large enough or deep enough to warrant myomectomy also likely warrants recommendation for cesarean delivery. Whereas myomectomy offers limited, if any, benefits to young women with infertility of short duration and other infertility factors amenable to nonsurgical treatments, it is less difficult to justify in older women with unexplained infertility of long-duration planning to pursue IVF.<sup>597</sup>

Adherence to basic microsurgical principles—gentle tissue handling, meticulous hemostasis, and minimal exposed suture—helps to ensure best surgical results. Adjuvants such as local injection of aqueous Pitressin, tourniquets to compress the uterine arteries, and surgical adhesion barriers aim at those goals. Laparoscopic and robotic myomectomy, performed by those having the requisite training and experience, may offer the same benefits as traditional open or minilaparotomy myomectomy for infertile women with intramural myomas and have the added advantage of lower morbidity (decreased blood loss and shorter recovery time).<sup>598,599,600,601,602</sup> A multicenter, randomized trial comparing reproductive outcomes after laparoscopic and minilaparotomy myomectomy in women with unexplained infertility observed no differences in cumulative pregnancy, live birth, and miscarriage rates between the two procedures.<sup>599</sup> There are concerns regarding myoma morcellation and the risk of

dissemination of malignant tissue, if the tumor turns out to be a sarcoma. The U.S. Food and Drug Administration has provided guidance that limits the use of power morcellation of uterine tissue. These risks should be reviewed with women who consider laparoscopic myomectomy with morcellation.

**The careful selection of patients most likely to benefit from myomectomy is far more important than the choice of surgical technique. If the procedure has little or no likely benefit, the choice of technique is irrelevant.**

# Intrauterine Adhesions (Asherman Syndrome)

Intrauterine adhesions develop as a result of trauma.<sup>603,604,605,606</sup> Any insult severe enough to remove or destroy the endometrium can cause adhesions. The gravid uterus is particularly susceptible to injury, especially between the second and fourth weeks postpartum.<sup>607</sup> Inflammation or infection also may predispose to adhesions.<sup>608,609,610</sup> In approximately 90% of cases, intrauterine adhesions relate to curettage for pregnancy complications, such as missed or incomplete abortion or retained products of conception.<sup>611</sup> Adhesions also can develop after abdominal or hysteroscopic myomectomy, septum resection, or other uterine surgery. In the developing world, genital tuberculosis is an important cause of intrauterine adhesions; although rare in the United States, the possibility must be considered in women emigrated from regions where the disease is prevalent.<sup>612</sup>

Intrauterine adhesions can be asymptomatic or cause menstrual disorders (hypomenorrhea, amenorrhea, dysmenorrhea), pain, recurrent miscarriage, or infertility.<sup>605,606</sup> The overall incidence of intrauterine adhesions is uncertain, but may be increasing.<sup>611,613</sup> The risk of intrauterine adhesions associated with elective termination of pregnancy is generally low, but the prevalence and severity of adhesions may increase with the number of procedures.<sup>614</sup> A temporal relationship between symptoms and a predisposing event, the inability to pass a uterine sound, or a negative progestin challenge in amenorrheic women suggest the diagnosis. When suspected, HSG and saline sonohysterography confirm the presence of intrauterine adhesions. Compared to hysteroscopy (the gold standard), HSG has approximately 80% sensitivity and specificity for diagnosis of adhesions.<sup>615</sup> A study comparing HSG and sonohysterography with hysteroscopy concluded the two methods of imaging were equally sensitive for detection of adhesions,<sup>513</sup> but hysteroscopy is required to define the location and extent of disease.

Hysteroscopy can reveal a variety of findings.<sup>603,610,616</sup> Central adhesive bands can appear as columns or bridges between the opposing walls of the cavity, dividing it into smaller irregular chambers of varying size and shape. Adhesions at the margins of the cavity often appear as half-drawn curtains that may obscure one or both cornual orifices. Depending on their composition (mucosal, fibromuscular, connective tissue), adhesions may or may not have a surface of the endometrium; dense connective tissue adhesions typically do not. Whereas mucosal adhesions generally appear similar to the surrounding normal tissue and are easy to lyse, fibromuscular and connective tissue adhesions are thicker, are typically pale, and must be mechanically divided or dissected. Numerous classification systems have been proposed, but no system has gained wide acceptance or has prognostic value validated by prospective studies.<sup>605,606</sup>

Consequently, outcome studies are difficult to interpret and compare.

Hysteroscopy is the method of choice for treatment of intrauterine adhesions and is both safer and more effective than blind curettage. Sometimes, the pressure provided by continuous infusion of distension media can lyse mild adhesions, or pushing the tip of the hysteroscope may suffice. When needed, an assortment of mechanical, electrosurgical, and laser-based instruments allows adhesions to be lysed or cut under direct vision. Indirect evidence suggests cold scissors are safer than electrosurgery regarding the risk of further endometrial damage.<sup>617</sup> In the case of severe adhesions, an HSG can serve as a roadmap for planning surgery. When possible, identification of anatomic landmarks as the tubal ostia helps proper dissection. Transabdominal ultrasound-guided office hysteroscopy enable orientation in an endometrial cavity obliterated by severe adhesions. Even though simultaneous laparoscopy is suggested as an aid to guide hysteroscopic adhesiolysis, it has several limitations. First and foremost, laparoscope does not allow the surgeon to understand the location of the hysteroscope in the orthogonal planes until the myometrium is too thinned to allow visualization of the light from the hysteroscope through uterine serosa with the laparoscope. A retrospective study suggests uterine perforation rates are lower with transabdominal ultrasound guidance than with laparoscopic guidance.<sup>618</sup> Increased cost and potential morbidity associated with laparoscopy should also be considered in the absence of another indication for laparoscopy.

Various methods have been used to facilitate hysteroscopic surgery or to improve outcomes. When available, office hysteroscope could be preferred for adhesiolysis since the smaller instruments can allow fine movements and does not require cervical dilation for the majority of women. Vaginal administration of misoprostol (200–400 µg) for cervical softening before operative hysteroscopy can reduce or eliminate the need for mechanical dilation and the incidence of operative complications.<sup>619</sup> However, routine use of vaginal misoprostol before office hysteroscopy can lead to leakage of distention medium through a softened cervix and render the procedure more difficult. Various physical barriers, including both unmedicated intrauterine device (IUDs) and balloon catheters, are commonly used as a means to maintain separation between the opposing layers of the endometrium during the immediate postoperative interval. Despite the absence of data on their effect on fertility, solid barriers reduce the rate of adhesion reformation. Balloon catheters shaped to mimic the uterine cavity are available specifically for this purpose. An IUD with a large surface area, such as the Lippes loop, which does not contain copper or progestin, should be preferred. Semisolid barriers such as hyaluronic acid gel also reduce adhesion formation. The absence of the need for removal and better conforming the contours of endometrial cavity can be regarded as advantages of hyaluronic acid gel over solid barriers; however, there are no comparative studies reporting pregnancy rates following the use



of solid or semisolid barriers.<sup>617</sup> Postoperative treatment with exogenous estrogens to promote rapid re-epithelialization and reduce risks of recurrent adhesions is frequently used, but its efficacy has not been established,<sup>617</sup> a typical regimen involves treatment with 2–6-mg estradiol daily for 4 weeks, adding a progestin (e.g., medroxyprogesterone acetate 10 mg daily) during the last week.

Complications of hysteroscopic adhesiolysis are the same as with any operative hysteroscopic procedure and are relatively uncommon. Acute complications include uterine perforation, fluid overload and electrolyte imbalance, hemorrhage, and infection; late complications include recurrent adhesions and uterine rupture in a subsequent pregnancy.<sup>620</sup>

Surgical results should be evaluated by HSG or saline sonohysterography after menses.<sup>621</sup> A second operation to lyse persistent or recurrent adhesions may be required when disease is severe. Alternatively, pressure lavage with normal saline under guidance of TVUS can be used to hydrodissect recurrent adhesions that are not particularly dense or extensive.<sup>622</sup> Lysis using a balloon catheter under fluoroscopic control and local anesthesia or intravenous sedation also has been described.<sup>623</sup> Normal cyclic menses can be restored in from 70% to 90% of women with intrauterine adhesions, depending on severity.<sup>603</sup> Conception and term delivery rates after successful hysteroscopic lysis of intrauterine adhesions have ranged between 25% and 75%<sup>603,610,624,625,626,627,628,629,630</sup>; predictably, the prognosis is better for women with mild disease.

# Endometrial Polyps

Endometrial polyps are hyperplastic endometrial growths with a vascular center and a sessile or pedunculated shape extending into the uterine cavity. They are generally rare in young women and increase in incidence with age. The true prevalence of polyps among infertile women is unknown and varying figures are reported.<sup>631</sup> While one study reported a prevalence of 15.6% among women with unexplained infertility, the figure ranged between 1.4 and 8% among women undergoing ART.<sup>632,633</sup> A number of molecular mechanisms have been implicated in their pathogenesis, including endometrial hyperplasia,<sup>634</sup> overexpression of endometrial aromatase,<sup>603,635</sup> and gene mutations.<sup>636</sup> Saline sonohysterography is the most useful method of imaging for detection of endometrial polyps,<sup>533,637,638</sup> although false-positive results due to blood clots, mucus, and shearing of normal endometrium are not uncommon.

Careful, systematic evaluation inevitably will identify polypoid cavitory lesions in some infertile women. Differentiation of small submucous myomas and endometrial polyps can be difficult by any means other than hysteroscopy.<sup>512</sup> Whereas symptomatic women (abnormal bleeding) certainly merit hysteroscopic evaluation and treatment, whether surgery has benefits for asymptomatic infertile women with polyps is less clear. The observation that polyps are resistant to the actions of progesterone suggests they might interfere with implantation<sup>639</sup>; local inflammatory changes and distortion of the uterine cavity also have been implicated.<sup>640</sup>

Evidence from studies examining reproductive performance after hysteroscopic polypectomy is rather weak and conflicting.<sup>184,185,640,641</sup> In a study of infertile women with documented but unresected endometrial polyps (<2 cm), IVF outcomes in treated (preliminary hysteroscopic polypectomy) and untreated women were not different.<sup>185</sup> In two studies examining outcomes in women with polyps (<1.5–2 cm) identified by ultrasonography during ovarian stimulation for IVF, pregnancy rates in women who proceeded to oocyte retrieval and embryo transfer or had hysteroscopic polypectomy after retrieval and later frozen embryo transfer were not different from those in women without polyps having fresh or frozen embryo transfers.<sup>632,642</sup> The evidence indicating that polyps adversely affect fertility derives from two randomized controlled trials comparing outcomes after up to four cycles of IUI in infertile women with polyps who underwent preliminary polypectomy or no treatment.<sup>641,643</sup> Two hundred thirty and 120 women were randomized in these trials, and both showed significantly higher pregnancy rates following polypectomy (63.4% vs. 28.2% and 41.7% vs. 20%).<sup>641,643</sup> Overall, hysteroscopic polypectomy results in a greater than twofold increase in clinical pregnancy among subfertile or infertile women who subsequently undergo IUI.<sup>644</sup>

Similarly, a retrospective study reported higher natural conception rates among infertile women who had hysteroscopic polypectomy compared with those who had hysteroscopy with a normal cavity (78% vs. 42.1%).<sup>184</sup> A recent US cost analysis study suggests that pretreatment office or operative hysteroscopic polypectomy is cost-effective when performed prior to both IUI and IVF over a range of plausible pregnancy rates and procedural costs.<sup>645</sup>

**Taken together, the available evidence suggests that polypectomy may improve reproductive performance in infertile women. Treatment must be individualized, depending on the size of a polyp, associated symptoms, and circumstances leading to its discovery.**<sup>646,647</sup>

# Chronic Endometritis

Chronic endometritis has been regarded traditionally as a distinct but uncommon cause of reproductive failure, but its true prevalence in infertile women is unknown.<sup>648</sup> Available evidence suggests that chronic subclinical endometritis is relatively common in women with symptomatic lower genital tract infections, including cervicitis and recurrent bacterial vaginosis.<sup>649,650,651,652</sup> Mucopurulent cervicitis is highly associated with chlamydia (*Chlamydia trachomatis*) and mycoplasma (*Mycoplasma genitalium*) infection, and both organisms, in turn, are associated with chronic endometritis, which likely plays a role in the pathogenesis of tubal factor infertility.<sup>494,652,653,654,655,656</sup> However, the data regarding the true prevalence and importance of chronic endometritis in asymptomatic infertile women are contradictory. While some retrospective studies suggest that up to 57–66% of women with unexplained infertility or unexplained recurrent implantation failure are diagnosed with chronic endometritis, in a prospective study involving 678 asymptomatic women who would undergo their first ART cycle, the prevalence of chronic endometritis diagnosed by hysteroscopic biopsy was 2.8%.<sup>657,658,659</sup> In addition, women with and without chronic endometritis had similar cumulative live birth rates (76% vs. 54%, in women with and without chronic endometritis, respectively), and clinical pregnancy rate per embryo transferred was similar between the groups. Therefore, routine serologic testing for past chlamydia exposure, cervical cultures, and endometrial biopsy may be difficult to justify. However, further evaluation and treatment may be appropriate and prudent in infertile women with clinical cervicitis, chronic or recurrent bacterial vaginosis, or other symptoms that suggest pelvic infection.

# TUBAL FACTOR: TUBAL OCCLUSION AND ADNEXAL ADHESIONS

---

Tubal and peritoneal pathology is among the most common causes of infertility and tubal pathology accounts for 25–35% of female infertility.<sup>660</sup> **A history of pelvic inflammatory disease (PID), septic abortion, ruptured appendix, tubal surgery, or ectopic pregnancy strongly suggests the possibility of tubal damage.** Unquestionably, PID is the major cause of tubal factor infertility and ectopic pregnancies. Classic studies in women with PID diagnosed by laparoscopy revealed that the risk of subsequent tubal infertility increases with the number and severity of pelvic infections; overall, the incidence is approximately 10–12% after one episode, 23–35% after two, and 54–75% after three episodes of acute PID.<sup>661,662,663,664,665</sup> The risk of ectopic pregnancy is increased six- to sevenfold after pelvic infection. Although many women with tubal disease or pelvic adhesions have no known history of previous infection, evidence suggests strongly that “silent” ascending infection is the most likely cause.<sup>652,656</sup> Many such women will have detectable chlamydia antibodies suggesting prior infection (discussed below). Other causes of tubal factor infertility include inflammation related to endometriosis, inflammatory bowel disease, or surgical trauma. Endometriosis is considered at length in [Chapter 32](#); discussion here is focused on intrinsic tubal disease.

The mechanism responsible for tubal factor infertility obviously involves anatomic abnormalities that prevent the union of sperm and ovum. Proximal tubal obstructions prevent sperm from reaching the distal fallopian tube where fertilization normally occurs. Distal tubal occlusions prevent ovum capture from the adjacent ovary. Whereas proximal tubal obstruction is essentially an all-or-none phenomenon, distal tubal occlusive disease exhibits a spectrum ranging from mild (fimbrial agglutination) to moderate (varying degrees of fimbrial phimosis) to severe (complete obstruction). The likelihood or efficiency of ovum capture probably is inversely related to the severity of disease. Inflammatory damage to internal tubal mucosal architecture cannot be detected easily but may nonetheless impair sperm or embryo transport functions.

HSG and laparoscopy are the two classic methods for evaluation of tubal patency in infertile women and are complementary rather than mutually exclusive; each provides information the other does not and each has advantages and disadvantages. HSG images the uterine cavity and reveals the internal architecture of the tubal lumen, neither of which can be evaluated by laparoscopy. Laparoscopy provides detailed information about the pelvic anatomy that HSG cannot, including adhesions, endometriosis, and ovarian pathology. HSG is performed in an outpatient setting, is far less costly than laparoscopy, and may have some therapeutic value<sup>666</sup>; it also is often uncomfortable or

painful, involves some radiation exposure, and has risk of infectious complications that can further impair fertility.<sup>667</sup> Rare cases of shock and pulmonary and cerebral embolus and a case of hyperthyroidism due to iodine absorption have been reported following the use of oil-soluble media.<sup>668,669</sup> Laparoscopy is more invasive, usually requires general anesthesia, provides no information regarding the uterine cavity (unless hysteroscopy is also performed), and involves the usual risks of surgery. Sonohysterosalpingography (sonoHSG) is similar to HSG, using ultrasonography and sterile saline instead of fluoroscopy and contrast media, and is another, but less common, method for evaluating tubal factor. Hysterosalpingo-contrast sonography (HyCoSy) is similar to sonoHSG, but either contrast media or a more recently developed gel comprised of hydroxyethyl cellulose and glycerol is used for demonstrating fallopian tubes. Chlamydia antibody tests represent a fifth, albeit indirect, method for evaluating tubal factor that is relatively inexpensive and minimally invasive.<sup>670,671,672,673</sup> Chlamydia antibody tests have been used primarily for screening infertile women to identify those at high risk for having tubal disease who merit evaluation with laparoscopy.

# Hysterosalpingography

HSG is best scheduled during the 2–5-day interval immediately following the end of menses, to minimize the risk for infection, to avoid interference from intrauterine blood and clot, and to prevent any possibility that the procedure might be performed after conception. Even the most sensitive assays for hCG cannot exclude the possibility of pregnancy when HSG is performed during the early luteal phase of the cycle. HSG does not require any specific preparation, although pretreatment with a NSAID (30–60 minutes before) is helpful to decrease discomfort associated with the procedure; more potent analgesics and sedatives generally are not required. For those who are seeking alternative pain control measures, effectiveness of other oral analgesics is unclear, while improved pain relief with a single rectal dose of 50-mg indomethacin 30 minutes before HSG has been reported.<sup>674,675</sup> Infectious complications from HSG are relatively uncommon, even in high-risk women (1–3%).<sup>667,668,669,676</sup> Even though prophylactic antibiotic treatment is not absolutely necessary for everyone, it can be justified considering the potential consequences of a postprocedure infection. **Treatment with antibiotics (doxycycline 100 mg twice daily for 5 days, beginning 1–2 days before HSG) is prudent when tubal disease is highly suspected, and specifically indicated when HSG reveals distal tubal obstruction, because risk for acute salpingitis is increased (approximately 10%) and treatment can prevent clinical infection.**<sup>667,677</sup> To minimize the risk of infection, HSG is best avoided altogether for at least several weeks following any episode of acute PID.

The technique for performing an HSG is quite standard. The study should be performed using image intensification fluoroscopy with a limited number of radiographs. The average HSG requires only 20–30 seconds of fluoroscopic time with minimal radiation exposure and has very low risk. Usually, only three basic films are required (a scout, one film to document the uterine contours and tubal patency, and a postevaluation film to detect any areas of contrast loculation). Additional oblique films may be needed when the uterus obscures the tubes or the uterine cavity appears abnormal. Otherwise, they provide little or no more useful information and increase radiation exposure unnecessarily.<sup>678</sup> Contrast can be introduced using a common metal “acorn” cannula, a cervical vacuum cup device, or a balloon catheter. In general, the latter techniques require less fluoroscopic time and smaller volumes of contrast, produce less pain, and are easier to perform.<sup>679,680,681</sup> Slow injection of contrast (typically 3–10 mL) helps to minimize the discomfort associated with HSG.

Debate regarding the relative advantages and disadvantages of oil- and water-soluble contrast media has raged for years. Advocates of water-soluble contrast media emphasize that oil-soluble medium is too viscous to reveal internal tubal architecture

(having prognostic significance),<sup>682</sup> disperses poorly in the pelvis (and therefore cannot detect adnexal adhesions), and has significant risks (granulomatous reactions, intravasation, and embolism).<sup>683,684</sup> Those favoring oil-soluble contrast media argue that granulomatous reactions are rare and that intravasation and embolization are uncommon and almost uniformly benign<sup>685</sup> and cite evidence suggesting that oil-soluble media increase fertility in the months immediately following HSG in women with patent tubes.<sup>666</sup> A systematic review including five randomized controlled trials directly comparing pregnancy rates following HSG with oil contrast and those after HSG with water contrast reported similar pregnancy rates (odds ratio, 1.4; 95% CI = 0.8–2.5).<sup>666</sup> However, the original trials were methodologically limited. A more recent, methodologically sound trial randomized 1,119 women to HSG with oil or water contrast.<sup>686</sup> Despite identification of a similar number of women with tubal pathology, live birth rates with a combination of expectant management and IUI were significantly higher following the use of oil-based media (rate ratio, 1.38; 95% CI = 1.17–1.64;  $P < 0.001$ ).

HSG may reveal bilateral tubal patency (60–75%) or unilateral (15–25%) or bilateral (15–25%) tubal occlusion.<sup>687,688</sup> Both false-positive (obstructions that are not real) and false-negative results (patency that is not real) occur, the former being much more common than the latter. Injection of contrast may cause “cornual spasm” (uterine contractions that transiently close the interstitial segment and prevent distal perfusion) that can be misinterpreted as proximal tubal occlusion. HSG may reveal unilateral tubal patency and contralateral proximal occlusion. Although the observation may represent a true unilateral proximal obstruction, which is rare, catheter placement allowing contrast to take the path of least resistance is the more common cause; most often, the nonvisualizing tube is normal. A false-negative HSG may occur when the contrast entering a widely dilated hydrosalpinx is diluted to yield a blush that is misinterpreted as evidence of tubal patency. Peritubular adhesions surrounding an otherwise normal and patent tube can sequester contrast as it escapes from the tube, resulting in a focal loculation that can be misinterpreted as distal obstruction.

Compared to laparoscopy (the gold standard method) as a test of tubal patency, HSG has an overall sensitivity (ability to detect obstruction when the tubes appear obstructed at laparoscopy) of 94% (95% CI = 74–99%) and specificity (confirmation at laparoscopy when obstruction is detected by HSG) of 92% (95% CI = 87–95%).<sup>689</sup> Thus, if HSG shows patent tubes, tubal blockage is highly unlikely.<sup>690</sup> However, after a HSG that showed proximal tubal blockage, 60% of such women had tubal patency with a repeat HSG 1 month later.<sup>691</sup> Subsequent laparoscopy revealed a similar percentage of women having tubal patency following proximal tubal occlusion on HSG.<sup>690</sup> The PPV and NPV of HSG for tubal occlusion are 38% and 94%, respectively.<sup>690,692,693</sup> **The**



**clinical implications are that when HSG reveals obstruction, there is still a relatively high probability (approximately 60%) that the tube is open, but when HSG demonstrates patency, there is little chance the tube is actually occluded (approximately 5%).** However, interpretation of HSG results can vary significantly among different observers.<sup>694,695</sup> Consequently, when the treating clinician has not performed the HSG, a personal review of the films is prudent before making recommendations for additional evaluation or treatment. The probability of treatment-independent pregnancy is highest when HSG reveals bilateral tubal patency, substantially lower when neither tube is open, and reduced only slightly when one tube is patent.<sup>687,688</sup> These observations help in deciding whether laparoscopy is needed before starting treatment.

# Laparoscopy

Laparoscopy is regarded generally as the definitive test for the evaluation of tubal factors. Issues concerning the scheduling, the use of antibiotics, and the risks of infectious complications are the same as for HSG. Diagnostic laparoscopy is usually performed under general anesthesia, but may require only deep sedation and local anesthetic; operative laparoscopy for treatment of disease typically requires general anesthesia. With few exceptions, a systematic and thorough inspection of the pelvis will accurately define the location and extent of any disease. Examination should include the uterus, the anterior and posterior cul-de-sacs, the ovarian surfaces and fossae, and the fallopian tubes. Injection of a dilute blue dye through a cannula attached to the cervix or an intrauterine manipulator permits evaluation of tubal patency (“chromotubation”). Indigo carmine is preferred over methylene blue, which rarely may induce acute methemoglobinemia, particularly in individuals with glucose-6-phosphate dehydrogenase deficiency.<sup>696,697</sup> As with HSG, slow injection of fluid helps to reduce the incidence of false-positive results.

Laparoscopy provides both a panoramic view of the pelvic reproductive anatomy and a magnified view of the uterine, ovarian, tubal, and peritoneal surfaces. Consequently, it can identify milder degrees of distal tubal occlusive disease (fimbrial agglutination, phimosis), pelvic or adnexal adhesions, and endometriosis that adversely affect fertility but escape detection by HSG. Most importantly, laparoscopy offers the opportunity to treat disease at the time of diagnosis. Lysis of filmy or focal adhesions and excision or ablation of superficial endometriosis are relatively simple procedures well within the capabilities of most surgeons. Excision of ovarian endometriomas, lysis of dense or extensive adhesions involving the cul-de-sac or bowel, excision or ablation of widely disseminated or deeply invasive endometriosis, and fimbrioplasty or salpingoneostomy procedures require greater technical skill and experience.

Although laparoscopy is a better predictor of future fertility than HSG, it is not a perfect test for diagnosis of tubal pathology. Intraoperative chromotubation is subject to the same pitfalls causing false-positive results with HSG. False-negative results with laparoscopy are uncommon but do occur, particularly in cases where the fallopian tubes are obscured by adhesions. Whereas tubal obstructions detected by HSG are frequently not confirmed at laparoscopy, patency almost always is. Laparoscopy also is a better predictor of future treatment-independent pregnancy than HSG because the information gained is more accurate. Again, the prognosis is best when both fallopian tubes are patent, poor when both are blocked, and intermediate when only one tube is open.<sup>688,698</sup> Because many obstructions detected by HSG are not real and all but a few of those identified by laparoscopy are, the prognoses associated with unilateral and bilateral tubal occlusion diagnosed by laparoscopy are significantly worse than when the same

diagnosis is made by HSG.

# Sonohysterosalpingography and Hysterosalpingo-Contrast Sonography

Sonohysterography is recognized as having greater sensitivity than HSG for detection of intrauterine pathology. A natural extension of that technique, sonoHSG, has been viewed as a means to evaluate tubal patency at the same time, much like HSG. As originally described, sonohysterosalpingography (sonoHSG) relied on observations of fluid accumulation in the cul-de-sac as an indication of tubal patency. However, the technique provided no information regarding tubal anatomy and could not determine whether one or both tubes were patent. Introduction of a sonographic contrast medium consisting of a surfactant that produces microbubbles when stimulated by ultrasound improved sensitivity for detecting tubal patency, but the standard two-dimensional imaging in the sagittal and transverse planes was still inadequate to visualize the three-dimensional tubal anatomy.

Technologic advances in ultrasonography and introduction of new contrast media further expanded the capabilities of sonoHSG and hysterosalpingo-contrast sonography (HyCoSy). Three-dimensional TVUS provides the means to generate coronal images. Color-coded Doppler techniques have improved visualization of fluid movement through the fallopian tubes. A 2014 meta-analysis showed that pooled estimates of sensitivity and specificity of sonoHSG/HyCoSy in comparison to laparoscopy were 92% (95% CI = 82–96%) and 95% (95% CI = 90–97%), respectively. There was no significant difference between the diagnostic performance of sonoHSG compared to HyCoSy.<sup>689</sup> Additional advantages of sonoHSG/HyCoSy are avoiding the risk of ionizing radiation, higher sensitivity and specificity for the detection of intrauterine pathologies, concomitant visualization of the ovaries and myometrium, and completion of assessment at the office without referral to radiology. Even though more recent studies suggest higher diagnostic performance of HyCoSy using the gel foam as the sonographic contrast as compared with sonoHSG using saline, widespread use is possibly limited with availability of and experience with the required equipment.<sup>699,700,701,702</sup>

# Chlamydia Antibody Tests

A number of studies have suggested that chlamydia antibody tests can be as accurate as HSG or even laparoscopy for detection of tubal pathology, including tubal occlusion, hydrosalpinx, and pelvic adhesions.<sup>670,671,703</sup> The performance of the different tests varies widely with the assay method. Commercial assays differ in detection method (immunofluorescence, microimmunofluorescence, ELISA, immunoperoxidase) and in the source of antigen they use (general or genus-specific major outer membrane proteins, an inactivated organism, whole-cell inclusion). Some methods are highly specific for the chlamydia species of interest (*C. trachomatis*), and others do not distinguish antibodies to *C. trachomatis* from those directed against other chlamydia species (*C. pneumoniae*, *C. psittaci*). As expected, tests having the greatest specificity for *C. trachomatis* perform best for detection of tubal pathology.<sup>671,704,705</sup> Practical considerations suggest that a rapid, highly sensitive but less specific assay is the most suitable test for screening, using a more specific test to confirm the antibody specificity of sera selected by the screening assay.

The predictive value of any diagnostic test depends on the prevalence of the disease of interest in the population tested. If the prevalence of disease in the population is very low or very high, diagnostic testing has little or no value because the outcome rarely affects management, and false-positive (when the prevalence is very high) or false-negative test results (when the prevalence is very low) are common. Diagnostic tests tend to have greatest utility when the prevalence of disease is somewhere in between the extremes.<sup>690</sup> Some have suggested that chlamydia antibody tests might be used to select patients likely to benefit most from laparoscopy, but the predictive value of even some of the more specific chlamydia antibody tests may not be sufficient to justify that approach.<sup>706</sup>

The role for chlamydia antibody tests in the evaluation of infertile women has not been sufficiently defined. Chlamydia antibody tests could prove useful as a pretest to select women who warrant earlier or more detailed evaluation.<sup>707</sup> If applied as a screening tool early in evaluation, a positive test might alert one to the possibility of tubal factors relating to previous chlamydia infection not otherwise suspected. Although selective laparoscopy based on chlamydia antibody tests may be unjustified for all infertile women,<sup>706</sup> it might be effective if limited to women with unexplained infertility (including a normal HSG), identifying those most likely to have undetected tubal factors best addressed before starting aggressive and costly empirical treatments. The utility of chlamydia antibody tests in these or other clinical contexts is uncertain but warrants further investigation. **In summary, chlamydia antibody tests can provide useful information, but also have pitfalls that limit their clinical utility. Currently,**

**diagnostic performance of chlamydia antibody testing is limited, and HSG or other imaging modalities remain the standard for assessment of tubal patency.**<sup>708,709</sup>

# Tubal Surgery in the Era of ART

For women with tubal factor infertility, treatment options are reconstructive surgery and IVF. Over the last 2 decades, IVF success rates have increased steadily (from approximately 10% to over 40%) and now frequently exceed those achieved with surgery.<sup>190</sup> Consequently, IVF has become the treatment of choice for much or most tubal factor infertility, particularly for couples with other infertility factors or severe tubal disease. However, surgery remains an appropriate option in select circumstances and for couples with ethical or religious objections or financial restrictions that preclude IVF. **The decision between surgery and IVF should be based on the following<sup>708</sup>:**

- **The age of woman**
- **Ovarian reserve**
- **Prior fertility status**
- **Number of children desired**
- **Site and extent of tubal damage**
- **Presence or absence of other factors necessitating IVF**
- **Surgeon's experience**
- **Success rate of IVF program**
- **Patient preference, that is, religious belief, cost, and insurance coverage for each option**

Younger women, women with normal/high ovarian reserve, proven fertility, desiring multiple children will comprise more appropriate candidates for surgical repair. A semen analysis of the male partner should precede the decision. It is difficult to directly compare success rates of surgery and IVF, since the former is usually reported per patient, whereas the latter is per cycle. Advantages of surgery are relatively lower cost, especially if multiple children are desired or several IVF cycles are likely to be undertaken to achieve a live birth. In addition to the cost issues, risk of multiple pregnancy, possible complications, and adverse obstetric and perinatal outcomes as compared with spontaneous pregnancies are other disadvantages of IVF.<sup>710</sup> The indications, preliminary evaluation, techniques, risks, and outcomes for IVF and other forms of ART are the focus of a separate chapter ([Chapter 28](#)); discussion here is limited to surgical treatments for tubal factor infertility and the choice between surgery and IVF.

## Sterilization Reversal

Approximately 1 million US women have an elective tubal sterilization procedure each year; up to 30% regret the decision and about 1% later request its reversal.<sup>23,711,712,713</sup>

The most commonly cited reasons for sterilization reversal requests include new relationships, changes in family planning goals, and death of a child. Regrets are more common in younger women, those who were unaware of the spectrum of contraceptive options, women whose decision for sterilization was influenced by a third party (partner, other family member, friend, or physician), and those sterilized postpartum or after an abortion.<sup>711,712,714,715</sup> Women 30 years old or younger are twice as likely as older women to express regret, 3.5–18 times more likely to request information about reversal of the procedure, and approximately 8 times more likely to actually have a sterilization reversal or IVF.<sup>711,712,716</sup> For women who want to conceive again, tubal anastomosis is a legitimate option. A preoperative HSG can be useful to assess the proximal segments and to confirm the type of sterilization performed. Laparoscopy may occasionally be necessary to assess the feasibility of surgical repair when the type of procedure is unknown and when destruction or removal of large segments of tube or other pelvic pathology is suspected; otherwise, fewer than 5% of women will have irreparable tubes.<sup>717</sup>

**The most important prognostic factor for achieving a live birth after microsurgical sterilization reversal is age. The type and location of procedure and the final length of the repaired fallopian tubes are also thought to play a role.** Younger women, those whose sterilization was performed using rings and clips, and women having no other infertility factors have the best prognosis; success rates are lower for older women, those who were sterilized by cautery (particularly multiple-burn techniques), and women with other infertility factors.<sup>718,719,720,721,722,723,724,725</sup> Cumulative pregnancy rates are similar when one or both tubes are repaired, although the time to conception is longer after unilateral anastomosis.<sup>724</sup> **In properly selected candidates, overall conception rates are generally quite good (45–82%) after microsurgical sterilization reversal.** Risk for ectopic pregnancy ranges between 2% and 10% and is higher after isthmic-ampullary than after isthmic-isthmic anastomoses.<sup>708,726,727</sup> Among all surgical treatments for tubal factor infertility, sterilization reversal has the highest postoperative fecundability. **The best candidates for the procedure are young women desiring more than one additional pregnancy and having no other infertility factors.** Laparoscopic tubal anastomosis abiding microsurgical principles by highly skilled surgeons experienced in the technique takes longer operation time but yields comparable pregnancy rates (25–53%).<sup>728,729,730</sup> While the use of robot can facilitate suturing for less experienced surgeons, early studies indicate that operating time is modestly greater, but hospital stay and recovery time are shorter, compared to open microsurgical procedures<sup>731,732</sup>; pregnancy rates are comparable, but risk for ectopic pregnancy may be increased.<sup>732</sup>



## Distal Tubal Obstruction

Distal tubal occlusive disease exhibits a wide spectrum of severity ranging from adherent fimbrial folds to varying degrees of phimosis, to complete obstruction with hydrosalpinges. HSG generally will reveal complete distal tubal obstructions but cannot reliably detect or accurately define lesser degrees of disease when the tubes are still patent. Laparoscopy is the definitive method for diagnosis of distal tubal occlusive disease and also provides the means for treatment. Fimbriolysis refers to the separation of adherent fimbria, fimbrioplasty describes the correction of phimotic but patent fimbria, and neosalpingostomy involves the reopening of a completely obstructed tube. Predictably, surgical success inversely relates to the severity of disease. The extent and character of associated tubo-ovarian adhesions, the tubal thickness, and the condition of the internal ampullary mucosal architecture are all variables that affect prognosis.<sup>733,734</sup> For the milder forms of distal tubal disease, postoperative live birth rates can exceed 50%.<sup>735,736,737</sup> Results achieved with surgery for more severe disease have varied widely, but success rates are lower (10–35%) and risk for ectopic pregnancy is higher (5–20%).<sup>734,738,739,740</sup> Postoperative tubal patency rates far exceed pregnancy rates; patency is more easily restored than function because mucosal regeneration is slow and often fails altogether.<sup>741,742</sup>

The majority of pregnancies occur within the first 2 years after surgical treatment of distal tubal obstruction. In general, the results achieved by experienced surgeons using traditional microsurgical techniques or laparoscopic methods have been similar. In a case series of 35 women with distal tubal occlusion treated by laparoscopic fimbrioplasty followed for at least 2 years after surgery, the global conception rate was 74%, the intrauterine pregnancy rate was 51%, the live birth rate was 37%, and the ectopic pregnancy rate was 23%.<sup>743</sup> **In younger women with mild distal tubal occlusive disease, laparoscopic surgery may be viewed as an alternative to IVF, but when disease is severe or pregnancy does not occur during the first postoperative year, IVF is the logical choice. For older women with any significant degree of distal tubal disease, IVF is generally the first and best option because cycle fecundability after distal tubal surgery is low (1–2%), time is limited, and IVF is both more efficient and more effective.**<sup>744</sup>

As success rates with IVF have improved steadily, the indications for reconstructive surgery in women with distal tubal occlusive disease have further declined. However, women with severe distal tubal disease still benefit from surgery because hydrosalpinges adversely affect IVF outcomes. Pregnancy, implantation, and delivery rates are decreased by approximately 50% and abortion rates are increased in the presence of hydrosalpinges.<sup>745,746</sup> Several mechanisms have been implicated to explain

the observation, including mechanical interference with implantation and toxic effects on the embryo or endometrium.<sup>747,748,749</sup> A 2010 systematic review including five randomized controlled trials involving 646 women observed that the odds of achieving an ongoing pregnancy were twice as great after laparoscopic salpingectomy for hydrosalpinges before IVF (OR = 2.14, CI = 1.23–3.73).<sup>750</sup> Laparoscopic occlusion of the fallopian tubes increased the odds of clinical pregnancy, compared to no intervention (OR = 4.66, CI = 2.47–10.01), and neither surgical procedure was superior.<sup>750</sup> **These data demonstrate clearly that laparoscopic salpingectomy or tubal occlusion improves IVF pregnancy rates in women with hydrosalpinges.** This holds true even when only one tube is affected. Moreover, removal or proximal occlusion of unilateral hydrosalpinx seems to improve chances of spontaneous pregnancy. A retrospective series including 25 women with unilateral hydrosalpinx reported 88% pregnancy rate without IVF with an average time to pregnancy of 5.6 months.<sup>751</sup> Similar observations are reported in other series.<sup>752,753</sup>

One concern with salpingectomy or even tubal occlusion or ligation is its impact on ovarian reserve. Despite contradictory results in early reports, salpingectomy does not impact ovarian reserve, perhaps except when it is done for ectopic pregnancy. Salpingectomy does not significantly decrease serum AMH concentration, ovarian response to stimulation, or clinical pregnancy rates with IVF.<sup>754,755</sup> Ovarian stimulation parameters and implantation and clinical pregnancy rates are similar in women who underwent salpingectomy or laparoscopic proximal tubal occlusion.<sup>756</sup>

Ultrasound-guided aspiration of hydrosalpingeal fluid at the time of oocyte retrieval has been suggested as an alternative treatment.<sup>757</sup> The procedure is effective in improving IVF outcome as compared to no intervention, simpler, and less costly than surgical options. However, salpingectomy and proximal tubal occlusion fare better than fluid aspiration with regard to ongoing pregnancy, clinical pregnancy, ectopic pregnancy, and miscarriage rates.<sup>758</sup> Moreover, the fluid reaccumulates rapidly.<sup>759</sup> Aspiration of hydrosalpingeal fluid can be an option reserved for women who are likely to have severe intra-abdominal adhesions prone to complications with pelvic surgery.

Essure is a 2-mm-thick and 4-cm-long microplug in its expanded form primarily used as a contraceptive device. Essure coil inserts have been used for occlusion of hydrosalpinges prior to IVF. Hysteroscopic placement of Essure coils are relatively easy; however, clinical pregnancy, implantation, and live birth rates following Essure are significantly lower than those achieved with laparoscopic management (salpingectomy or proximal occlusion) of hydrosalpinges.<sup>760</sup> Some evidence suggest that miscarriage rate is higher following Essure blockage of hydrosalpinges, as compared with other interventions.<sup>761</sup> Similar to hydrosalpinx aspiration, currently, Essure can be regarded as a second-line intervention for women under high risk of

intra-abdominal adhesions.

## Proximal Tubal Obstruction

Proximal tubal occlusions represent 10–25% of all tubal obstructions observed with HSG, many of which are not real (20–40%).<sup>660</sup> Mucus plugs, cellular debris, or uterotubal spasm can cause pseudo proximal obstruction. **Efforts to establish a certain diagnosis of true proximal tubal occlusion are justified; otherwise, many women may needlessly undergo major surgery or IVF.** Repeated HSG can decrease the number of false-positive tests of tubal patency; in a case series including 98 infertile women with a diagnosis of proximal tubal occlusion based on an HSG, repeating the procedure revealed bilateral tubal patency in 14 patients (14%), patency of 1 tube in 12 others (12%), and confirmed bilateral occlusion in 72 patients (74%).<sup>762</sup> Another series of 40 women, 18 with unilateral and 22 with bilateral proximal tubal occlusion, reported that 24 (60%) women achieved bilateral and 5 others achieved unilateral patency after a second HSG 1 month later.<sup>691</sup>

The pathogenesis of proximal tubal occlusive disease is not well understood; most is presumed to result from infection or chronic inflammation. Histologic studies suggest that obliterative luminal fibrosis is most common, followed by salpingitis isthmica nodosa (SIN), chronic inflammation, and intratubal endometriosis.<sup>660,763</sup> If proximal occlusion is not due to SIN, tubal cannulation using hysteroscopic or fluoroscopic methods is a proven alternative to traditional microsurgical repair. The specialized catheter systems involved require some training and experience but allow selective tubal perfusion for accurate diagnosis (true occlusion or not) and provide the means for treatment when needed.

A 2017 systematic review and meta-analysis pooled 27 studies involving women with proximal tubal occlusion.<sup>764</sup> Clinical pregnancy rate following tubal catheterization for unilateral or bilateral proximal tubal occlusion was 27% (95% CI = 25–30%). The pooled live birth and ectopic pregnancy rates were 22% (95% CI = 18–26%) and 4% (95% CI 3–5%), respectively. Pregnancy rates were not significantly different between tubal catheterization with hysteroscopic, laparoscopic, or fluoroscopic guidance (31% vs. 26%, respectively).<sup>764</sup> However, reocclusion rate of the opened tubes was approximately 30%,<sup>660</sup> and another study reported similar pregnancy rates following ovarian stimulation and IUI in women with untreated unilateral PTO and in those with unexplained infertility.<sup>765</sup> Yet, selective salpingography with catheterization immediately after HSG shows proximal occlusion can be an appropriate next step since it saves time for both physician and patient.

Microsurgical segmental tubal resection and anastomosis are a proven treatment for

true proximal tubal obstruction. Experienced surgeons can achieve pregnancy rates ranging between 50% and 60%,<sup>660,766,767,768</sup> but the number of surgeons having the necessary expertise is fast declining. Outcomes vary with the cause of the obstruction; reocclusion rates are relatively high with causes other than SIN.

Bipolar tubal disease involves both proximal and distal tubal obstructions. In general, success rates achieved with surgery have been extremely poor and IVF represents the best treatment option.<sup>767,769,770</sup> When cannulation fails, microsurgery may be considered if IVF is not an option.<sup>708</sup>

## **Summary: Tubal Surgery in the Era of ART**

Since only the best surgeons generally publish their results, the available estimates from surgical series also very likely represent the best possible outcomes. Even so, steady advances in ART have improved IVF outcomes to where they now exceed what can be achieved with tubal reconstructive surgery. Accordingly, surgical treatments for tubal factor infertility are generally in an era of decline; laparoscopic surgery has replaced simple open procedures, and ART has replaced more complicated ones. Tubal surgery remains a legitimate treatment option for women seeking pregnancy after a previous tubal sterilization, for those with mild distal tubal disease (particularly when they are young), and for some women with proximal tubal occlusion. Under virtually all other circumstances, IVF is the best choice. Laparoscopic salpingectomy or proximal tubal occlusion increases IVF success rates by twofold and should be recommended to all women with hydrosalpinges planning IVF.

# UNEXPLAINED INFERTILITY

---

Unexplained infertility is a diagnosis of exclusion, after systematic evaluation fails to identify a cause. The incidence of unexplained infertility ranges from 10% to as high as 30% among infertile populations, depending on diagnostic criteria.<sup>771,772,773</sup> **At a minimum, the diagnosis of unexplained infertility implies normal semen analysis, ovulatory function, a normal uterine cavity, and at least unilateral tubal patency.** Ruling out cervical factor by a postcoital test and LPD by endometrial biopsy and performing a diagnostic laparoscopy are no longer required for diagnosis of unexplained infertility.<sup>384</sup> Consequently, much of infertility previously attributed to cervical factors, LPD, and mild endometriosis or adhesions is now classified as “unexplained,” and couples with unexplained infertility comprise a very heterogenous group. As such, management is not aimed at correcting an underlying disorder; rather, the focus is on achieving pregnancy.

Excluding false-negative results of standard diagnostic tests, which do occur but are uncommon, there are two potential explanations for unexplained infertility: (1) there truly is no abnormality and the couple’s natural fertility is at the extreme lower end of the normal range, possibly due to female partner age or advanced reproductive aging, and (2) there is a specific cause, but not one that can be identified with existing diagnostic tests.

Undoubtedly, much of unexplained infertility relates to the natural decline in fertility with increasing age. Unexplained infertility is more common in women over age 35; in a study involving over 7,000 infertile women, those over the age of 35 years were nearly twice as likely to have unexplained infertility (OR = 1.8, CI = 1.4–2.7).<sup>377</sup> Yet, it is important to differentiate age-related infertility and unexplained infertility. Despite the natural decline in fertility with age, diagnostic criteria for infertility do not include age. A mathematical model of human conception according to a woman’s age suggests that the rate of false-positive diagnosis of unexplained infertility, in women who are infertile due to natural age-related decline in fertility, rises from 10% for women trying for a pregnancy before the age of 35–80% for women who start trying to conceive at age 40.<sup>774,775</sup> Older reproductive-age women may benefit from different management strategies for unexplained infertility compared to younger women. For instance, while younger women with unexplained infertility could be more likely benefit from IVF (as they could be expected to have occult ovulation defects, occult endometriosis, subtle disorders of tubal function that cannot be noticed with tests of tubal patency, or a male factor, which wouldn’t show by a standard semen analysis), more often than older women with age-related infertility, who may be less likely to benefit from IVF, since IVF cannot improve oocyte quality, or even substantially increase the number of oocytes

available for fertilization if the ovarian reserve is also decreased with age.<sup>774,775</sup>

**Logically, the most likely occult causes of infertility relate to abnormalities in gametes or implantation, for which there is no valid diagnostic test.** Genetic or functional abnormalities in zona pellucida proteins could interfere with sperm penetration and cause fertilization failure.<sup>776</sup> Abnormalities in the centrosome could interfere with normal spindle formation and function, preventing fertilization or resulting in arrested early embryonic development.<sup>777</sup> Although failed fertilization occurs in less than 5% of IVF cycles and does not always reoccur in subsequent cycles,<sup>778,779</sup> a marked decrease in fertilization efficiency easily could result in unexplained infertility. A higher incidence of fertilization failure has been observed in several, but not all, studies of IVF outcomes in couples with unexplained infertility.<sup>780,781,782,783</sup> Evidence that up to 75% of human pregnancies fail soon after conception implicates early embryopathy and implantation failure as likely causes of unexplained infertility.<sup>38,784,785</sup> Although aneuploidy is common in early human embryos,<sup>786,787</sup> a recurring nonrandom genetic defect in the embryo or trophoctoderm could cause early loss. Intrinsic genetic abnormalities in endometrial function and receptivity could interfere with apposition, adhesion, attachment, or invasion of the embryo, causing implantation failure.<sup>788,789,790</sup> **It is important to emphasize that all of the potential causes of unexplained infertility could coexist with known causes for infertility, helping to explain why many couples with identified ovarian, male, uterine, or tubal infertility factors fail to achieve a successful pregnancy despite receiving proven effective treatments.**<sup>791</sup>

Unexplained infertility likely represents either the lower extreme of the normal distribution of reproductive efficiency or abnormalities of sperm or oocyte function, fertilization, implantation, or embryo development that cannot be detected reliably by standard methods of evaluation. Although many couples with unexplained infertility may be expected to conceive without treatment, their already low and steadily declining cycle fecundity provides ample justification for offering treatment to those concerned enough to seek evaluation. The goal of treatment is to increase monthly fecundability to a level more closely approximating that observed in normally fertile couples.

The prognosis for untreated couples with unexplained infertility is similar to that for couples with minor infertility factors, such as mild oligospermia or endometriosis; age of the female partner and duration of infertility are the primary variables that affect pregnancy rates.<sup>380,792,793</sup> **In studies evaluating treatments for unexplained infertility, untreated patients have a cycle fecundability ranging typically between 2% and 4%,<sup>794</sup> or about 80–90% lower than in normal fertile couples (20–25%). The likelihood of pregnancy without treatment decreases progressively with increasing**

**age of the female partner and increasing duration of infertility.**<sup>380,795</sup> After 3 years of infertility, the likelihood of pregnancy without treatment falls to approximately 40%, and after 5 years to about 20%, of what it was when efforts to conceive first began.<sup>369</sup> Only approximately 14% of couples with unexplained infertility managed expectantly for up to 7 years achieve a pregnancy resulting in a live birth within a year; the prognosis is better when the female partner is under age 30.<sup>380,793</sup> **The effect of duration of infertility is important to understand. Because spontaneous pregnancy rates are highest among couples with a relatively short duration of infertility and success rates achieved with all forms of treatment for unexplained infertility other than IVF are similar, treatments can appear more effective in couples with a longer duration of infertility having a lower probability for conceiving without treatment.**

By definition, the cause of unexplained infertility is unknown. Consequently, all treatments for unexplained infertility are empiric. Although methods differ, the basic strategy is the same for all—to bring together more than the usual numbers of oocytes and sperm in the right place at the right time. To this end, the most common treatments include IUI, ovarian stimulation with clomiphene or gonadotropins and IUI, and IVF.

# Intrauterine Insemination

Although several studies have examined the effectiveness of IUI as treatment for unexplained infertility in natural cycles,<sup>484,502,794,796,797</sup> a 2006 meta-analysis concluded that none provided reliable data because of problems with design, such as crossover trials that do not include data from the first phase of the study or populations not limited to couples with unexplained infertility.<sup>798</sup> The two most informative studies were published more recently and included only couples with unexplained infertility or an abnormal postcoital test, with expectant management as the control treatment.<sup>799,800</sup> In the first trial (average age 32 years, average duration of infertility 2.5 years), 43 live births were observed among 191 couples receiving IUI (23%) over 6 months, compared to 32 in 193 couples (17%) managed expectantly.<sup>799</sup> Although the effect difference (6% over 6 months) was not significant (OR = 1.46, CI = 0.88–2.43), more women randomized to IUI judged their treatment acceptable. In the second trial (average age 30 years, average duration of infertility 1.7 years), 11 ongoing pregnancies were observed among 51 couples receiving IUI (22%), compared to 9 in 48 couples (19%) managed expectantly.<sup>800</sup> **The best available evidence suggests that treatment with IUI in natural cycles has no clinically important effects.**



# Clomiphene Citrate and IUI

Numerous studies have examined the effectiveness of clomiphene therapy without IUI as treatment for unexplained infertility.<sup>801,802,803,804</sup> However, only two are truly informative trials, including only patients with unexplained infertility, using placebo or expectant management as the control treatment.<sup>799,805</sup> In one trial (average age 30 years, average duration of infertility 4.3 years), 10 pregnancies were observed among 76 couples (13%) receiving clomiphene treatment over 290 cycles (3%/cycle), compared to 4 in 72 couples (6%) receiving placebo over 274 cycles (1%/cycle).<sup>805</sup> In the other (average age 32 years, average duration of infertility 2.5 years), 26 pregnancies were observed among 192 couples receiving clomiphene (14%), compared to 32 in 193 couples (17%) managed expectantly.<sup>799</sup> The differences between treatment and control pregnancy rates (per couple or per cycle) were not significant in either trial. **Although clomiphene is commonly used as a treatment for unexplained infertility, the best available evidence indicates it has no significant benefit.**

Combined treatment with clomiphene and IUI is commonly recommended for couples with unexplained infertility, but evidence for its effectiveness has been limited. In a review of 8 studies involving 932 treatment cycles, the estimated cycle fecundity was 5.6% with clomiphene and 8.3% with clomiphene and IUI.<sup>794</sup> The one trial (average age 33 years, average duration of infertility 3.5 years), including an untreated control group (timed intercourse), included patients with unexplained infertility or treated endometriosis.<sup>806</sup> Limiting analysis to cycles observed before crossover, 8 pregnancies were observed in 23 couples (35%) receiving clomiphene and IUI over 73 treatment cycles (11%/cycle), compared to 4 in 28 couples (14%) over 103 cycles (4%/cycle). The 7.1% absolute difference (CI = -1.0-15.2) in cycle fecundability was not significant, and even if it were, the treatment effect was quite modest; the calculated number needed to treat was 15, implying that one additional pregnancy might be expected for every 15 treatment cycles. However, a more recent trial compared cumulative live birth rates between 201 couples with unexplained infertility who were randomized to expectant management or IUI with either clomiphene or letrozole (only 7 women) ovarian stimulation for 3 cycles.<sup>807</sup> Average female age was 34, and average duration of infertility was 4.5 years. Women in the clomiphene/letrozole IUI group had a significantly higher cumulative live birth rate than expectantly managed women (31 [31%] live births among 101 women vs. 9 [9%] live births among 100 women; risk ratio [RR] 3.41, 95% CI = 1.71-6.79). Per-protocol analyses yielded similar results. Based on these figures, the number needed to treat is five; one additional live birth can be expected for every five women undergoing up to three cycles of clomiphene IUI.

Results of three other crossover trials involving control groups receiving an active

treatment (instead of placebo or no treatment) are difficult to interpret confidently, because no data were provided for the first phase of the study.<sup>808,809,810</sup> A fourth management trial (the fast track and standard treatment [FASTT] trial) compared outcomes in two groups, one randomly assigned to receive three cycles of treatment with clomiphene and IUI followed by up to six cycles of IVF and the other assigned to receive three cycles of clomiphene and IUI, followed by three cycles of treatment with gonadotropins and IUI, followed by up to six cycles of IVF.<sup>811</sup> Notably, 55 pregnancies were observed among 233 couples over 646 treatment cycles (8.5%/cycle) in the first group and 68 in 242 couples over 648 treatment cycles (10.5%/cycle) in the second; overall, 123 pregnancies were observed in 475 couples (26%) over 1,294 cycles (9.5%/cycle). Per-cycle pregnancy rates for CC/IUI, FSH/IUI, and IVF were 7.6%, 9.8%, and 30.7%, respectively. The overall pregnancy rate achieved with CC/IUI in the FASTT trial compares favorably with the expected 2–4% cycle fecundability among couples with unexplained infertility, which supports the use of clomiphene and IUI in the treatment of unexplained infertility. In two large retrospective studies involving a total of more than 8,000 cycles of treatment with clomiphene and IUI, cycle fecundability ranged between 5% and 10% per cycle after four to six cycles for women aged 40 years and younger and was under 5% for those over age 40.<sup>812,813</sup>

**In sum, considering the relatively modest cost and complexity (compared to the alternatives, discussed below), treatment with clomiphene and IUI can be justified because the cycle fecundability observed in large prospective and retrospective studies is significantly higher than can be expected in couples with unexplained infertility receiving no treatment.**

# Gonadotropins and IUI

Gonadotropin therapy without IUI for treatment of unexplained infertility has been evaluated in only a few clinical trials. In the largest of these trials, pregnancy rates resulting from treatment with gonadotropins and intracervical insemination were higher than was achieved with insemination alone, but the difference was small (3.6%).<sup>814</sup>

**Although treatment with gonadotropins alone can increase cycle fecundability, compared with no treatment, the effect is quite modest and no better than can be achieved by treatment with clomiphene and IUI.**

More commonly, gonadotropin treatment is combined with IUI for the treatment of unexplained infertility. Among four trials comparing gonadotropins and IUI with no treatment, two were crossover trials providing no results for the first phase of treatment.<sup>815</sup> In a US trial (average age 32 years, average duration of infertility 3.6 years), 77 pregnancies were observed among 231 couples (33%) receiving treatment with gonadotropins and IUI over 618 cycles (12%/cycle), compared to 23 pregnancies in 233 couples (10%) receiving intracervical insemination over 706 cycles (3%/cycle); pregnancy rates per couple were 18% for treatment with insemination alone and 19% for gonadotropins and IUI.<sup>814</sup> A Dutch trial (average age 33 years, average duration of infertility 2 years) observed 29 pregnancies among 127 couples (23%) receiving gonadotropins and IUI over 676 cycles (4%/cycle), compared to 34 in 126 couples (27%) managed expectantly over 737 cycles (5%/cycle).<sup>816</sup>

The differing results of the two trials emphasize again the influence of the duration of infertility on outcomes achieved with treatment for unexplained infertility. In the US trial, involving couples infertile for an average of 3.6 years, fecundability in those receiving treatment with gonadotropins and IUI (12%/cycle) was 9% higher than in couples receiving intracervical insemination (3%/cycle), and only 10% of couples in the latter group conceived. In the Dutch trial, involving couples with an average of 2 years of infertility and a better prognosis for achieving pregnancy without treatment,<sup>793</sup> fecundability of those receiving gonadotropins and IUI (4%/cycle) was no better than in couples managed expectantly (5%/cycle), and 27% of couples receiving no treatment conceived. Together, the results of the two trials indicate that treatment with gonadotropins and IUI has little benefit when the prognosis is reasonably good and modest benefit when the prognosis is poor (1 additional pregnancy for every 11 treatment cycles).

In a recent multicenter US trial, 900 women with unexplained infertility (average age 32.2 years, average duration of infertility 35 months) were randomized to ovarian stimulation and IUI up to 4 cycles with gonadotropin, clomiphene, or letrozole.<sup>817</sup> Clinical pregnancies occurred in 35.5%, 28.3%, and 22.4% of women and live birth in

32.2%, 23.3%, and 18.7%, respectively; pregnancy rates with gonadotropin were significantly higher than the rates with letrozole (absolute difference = -13.1, 95% CI = -20.3 to -6.0,  $p = 0.001$ ), but not with clomiphene alone (-7.2, 95% CI = -14.7-0.2). Per-cycle pregnancy rates were 12.3%, 7.9%, and 6.2% with gonadotropin, clomiphene, and letrozole, respectively. Despite the favorable trend in favor of gonadotropin over clomiphene, the former was associated with significantly higher multiple pregnancy rate, 31.8% versus 9.4% (22.4%, 95% CI = 11.6%-33.2%). Of note, while there were only twin pregnancies in the clomiphene and letrozole groups, 10 out of 34 multiple pregnancies were triplets in the gonadotropin group. This trial clearly shows that letrozole is not the agent of choice for ovarian stimulation IUI cycles for unexplained infertility. Regarding the comparison between gonadotropin and clomiphene, a Belgian trial randomized 330 couples (average female age 32 years, average duration of fertility 25.5 months) with unexplained infertility to ovarian stimulation IUI with low-dose gonadotropin or clomiphene at cycle level.<sup>818</sup> Gonadotropin starting dosage was 37.5-75 IU/day. Both clinical pregnancy (14.4% vs. 9%) and live birth rates (13.8% vs. 8.7%) were significantly higher in gonadotropin-stimulated cycles. Multiple live birth rates were similar between the groups (6.5% vs. 3.6%), while cycle cancellation rate was higher in the clomiphene group.<sup>818</sup>

The results of treatment with gonadotropins and IUI for unexplained infertility raise two clinically relevant questions. The first concerns what benefits treatment with gonadotropins and IUI might have in couples first treated with clomiphene and IUI and failing to conceive. The only data addressing the question directly come from the "FASTT" trial described above, in which 50 pregnancies were observed among 169 couples (30%) receiving treatment with gonadotropins and IUI over 439 cycles (11%/cycle) after failing to conceive over 3 cycles of treatment with clomiphene and IUI.<sup>811</sup> Although cycle fecundability (11%/cycle) was slightly higher than was achieved with clomiphene and IUI in the same population (9.5%/cycle), the difference is not clinically important, especially when considering the greater costs, complexity, and risks associated with the use of gonadotropins.

The second question relates to whether success with clomiphene and IUI depends on multifollicular development, and there are no reliable data that address the question directly.

A number of studies have examined the efficacy of various adjuvant treatments in couples receiving treatment with gonadotropin and IUI for unexplained infertility. The available evidence indicates that whereas pretreatment with a GnRH agonist does not improve outcomes,<sup>819</sup> based on a systematic review and meta-analysis, adding a GnRH antagonist to the treatment regimen might (OR = 1.4, CI = 1.1-1.8).<sup>820</sup> However, the original trials included heterogeneous populations with varying methodologic quality.

The results were heterogenous as well. Thus, routine use of GnRH antagonists in gonadotropin IUI cycles is not justified.

**In summary, treatment with gonadotropins and IUI is modestly effective treatment for couples with longer durations of unexplained infertility (>3 years) and should be considered for couples who fail to conceive during treatment with clomiphene and IUI and when clomiphene treatment fails to stimulate multiple follicular development, especially when IVF is not a viable option. Based on the results of the two large randomized trials mentioned above, gonadotropins and IUI could also be utilized as the first alternative; however, the concerns regarding multiple pregnancy often preclude this approach.**

# Assisted Reproductive Technology

Observations in ART cycles frequently provide insight into the possible causes of a couple's unexplained infertility because the procedures involved address or eliminate many of the unknown variables. Sperm and oocytes will be combined effectively. Fertilization and early embryonic development can be observed directly, and embryo transfer ensures that embryos will reach the endometrial cavity. Although the chromosomal composition of embryos and endometrial receptivity may seem like the only factors remaining, the list of unknowns is, in truth, much longer.

Few trials have compared ART with no treatment or a different treatment such as gonadotropins and IUI,<sup>821,822,823,824,825</sup> and only some has been limited to couples with unexplained infertility. In the 2015 US national summary of ART outcomes, the overall live birth rate per-cycle start for couples with unexplained infertility (all ages) was 29%.<sup>33</sup> When compared on a per-cycle basis, IVF is clearly superior to ovarian stimulation with IUI. However, other factors in addition to effectiveness are considered in decision-making. Given the more invasive nature, higher cost, and per-cycle success rate of IVF, trials have compared IVF with three to six cycles of ovarian stimulation cycles.<sup>823,824,825</sup> Three randomized controlled trials, all including women with an average age of 32–34 years and average duration of infertility about 2.5 years, compared IVF with ovarian stimulation IUI. The first multicenter Dutch trial randomized 116 couples to 1 cycle of IVF elective single embryo transfer or 3 cycles of ovarian stimulation IUI and reported similar ongoing pregnancy rates (24% vs. 21%).<sup>823</sup> Another multicenter Dutch trial randomized 602 women to 3 cycles of IVF with elective single embryo transfer, 6 cycles of natural cycle IVF, or 6 cycles of ovarian stimulation IUI and reported similar cumulative live birth rates of 52%, 43%, and 47%.<sup>824</sup> The most recent British trial randomized 207 women to 1 cycle of IVF or 3 cycles of ovarian stimulation IUI and reported similar cumulative live birth rates of 33.9% and 28.7%, respectively.<sup>825</sup> It is unclear which couples can benefit from IVF rather than ovarian stimulation IUI.<sup>826</sup>

**In summary, IVF is clearly the most effective treatment for couples with unexplained infertility, regardless whether it is the first or the last treatment.**

## **Summary: Treatment of unexplained infertility**

Overall, the effects of treatments for unexplained infertility other than IVF are relatively small. In many cases, treatment may only hasten pregnancy for couples who would ultimately conceive on their own, given time. IVF is the most effective treatment for unexplained infertility. Careful counseling is essential and must take into account the couple's age, the duration of infertility, and the outcome of any previous pregnancies; before treatment is recommended, an ovarian reserve test also is prudent.<sup>138</sup> Couples who choose treatment should be informed thoroughly about the relative costs, risks, prognoses, and logistical challenges associated with different treatments so that they may select the one that best meets their needs and preferences. Partners can have differing levels of concern about their infertility and tolerance for risk and uncertainty.<sup>827</sup> Together, the medical evidence and shared decision-making determine the choice of management.<sup>828</sup>

# ADOPTION

---

With proper evaluation and treatment, the majority of couples evaluated for infertility will achieve pregnancy. For those who fail treatments, ART with donor eggs and/or a gestational surrogate and adoption are realistic options. Couples considering adoption have a wide range of choices including social agency adoptions, private adoptions, and international adoptions. In some states, private adoption is not legal, but where it is, private adoption can be an effective, more rapid alternative to adoption through a social agency. In most cases, the biologic mother has the opportunity to know the adopting parents and may reconsider her decision and reclaim her child for a time before the adoption is finalized. Those who prefer anonymity or who wish to avoid such potentially devastating disappointments likely will make a different choice. Couples interested in adoption should be referred to those knowledgeable about adoption laws in individual states and all of the available options.



# REFERENCES

1. **Practice Committee of the American Society for Reproductive Medicine**, Definitions of infertility and recurrent pregnancy loss, *Fertil Steril* 99(1):63, 2013.
2. **Wang X, Chen C, Wang L, Chen D, Guang W, French J**, Conception, early pregnancy loss, and time to clinical pregnancy: a population-based prospective study, *Fertil Steril* 79:577, 2003.
3. **Gnoth C, Godehardt D, Godehardt E, Frank-Herrmann P, Freundl G**, Time to pregnancy: results of the German prospective study and impact on the management of infertility, *Hum Reprod* 18:1959, 2003.
4. **Thoma ME, McLain AC, Louis JF, King RB, Trumble AC, Sundaram R, Buck Louis GM**, Prevalence of infertility in the United States as estimated by the current duration approach and a traditional constructed approach, *Fertil Steril* 99(5):1324.e1, 2013.
5. **Centers for Disease Control and Prevention**, National Survey of Family Growth, [https://www.cdc.gov/nchs/nsfg/key\\_statistics/i.htm#infertility](https://www.cdc.gov/nchs/nsfg/key_statistics/i.htm#infertility). Accessed on January 16, 2018.
6. **Martin JA, Hamilton BE, Osterman MJK, Driscoll AK, Mathews TJ**, Births: final data for 2015, *Natl Vital Stat Rep* 66:1, 2017.
7. **Ventura SJ, Martin JA, Curtin SC, Mathews TJ**, Report of final natality statistics, 1996, *Mon Vital Stat Rep* 46:1, 1998.
8. **Ventura SJ, Hamilton BE, Sutton PD**, Revised birth and fertility rates for the United States, 2000 and 2001, *Natl Vital Stat Rep* 51:1, 2003.
9. **Ryan CL, Bauman K**, Educational Attainment in the United States: 2015, in *Current Population Reports*, U.S. Census Bureau, Washington, D.C., 2016.
10. **Bureau of Labor Statistics, Employment Projections**, Civilian Labor Force Participation Rate by Age, Sex, Race and Ethnicity, October 24, 2017, [https://www.bls.gov/emp/ep\\_table\\_303.htm](https://www.bls.gov/emp/ep_table_303.htm)
11. **Norton AJ, Miller L**, United States Bureau of the Census, Marriage, divorce, and remarriage in the 1990's, U.S. Census Bureau, Washington, D.C., 1992.
12. **Kreider RM, Ellis R**, Number, Timing, and Duration of Marriages and Divorces: 2009. *Current Population Reports*, U.S. Census Bureau, Washington, D.C., 2011, pp. 70–125.
13. **Kreider R, Fields J**, Number, Timing, and Duration of Marriages and Divorces, 1996, U.S. Dept. of Commerce Economics and Statistics Administration, U.S. Census Bureau, Washington, D.C., 2002.
14. **National Center for Health Statistics (U.S.)**, Vital Statistics of the United States: Marriage and Divorce for 1989 to 1995, U.S. Dept. of Health and Human Services, Centers for Disease Control and Prevention, National Center for Health Statistics, Hyattsville, MD; Washington, D.C., 1997.
15. **National Center for Health Statistics (U.S.)**, Advance report of final marriage statistics, 1989 and 1990, *MVSR* 43, 1995.
16. **Martin JA, Hamilton BE, Sutton PD, Ventura SJ, Menacker F, Munson ML**, Births: final data for 2002, *Natl Vital Stat Rep* 52:1, 2003.
17. **The World Factbook**, <https://www.cia.gov/library/publications/the-world-factbook/>
18. **Abma JC, Chandra A, Mosher WD, Peterson LS, Piccinino LJ**, Fertility, family planning, and women's health: new data from the 1995 National Survey of Family Growth, *Vital Health Stat* 23:1, 1997.
19. **Chandra A, Stephen EH**, Impaired fecundity in the United States: 1982–1995, *Fam Plann Perspect* 30:34, 1998.
20. **Stephen EH, Chandra A**, Declining estimates of infertility in the United States: 1982–2002, *Fertil Steril* 86:516, 2006.
21. Key Statistics from the National Survey of Family Growth 2011–2015, <https://www.cdc.gov/nchs/fastats/infertility.htm>
22. **Mascarenhas MN, Flaxman SR, Boerma T, Vanderpoel S, Stevens GA**, National, regional, and global trends in infertility prevalence since 1990: a systematic analysis of 277 health surveys, *PLoS Med* 9(12):e1001356, 2012. doi:10.1371/journal.pmed.1001356.
23. **Stephen EH, Chandra A**, Use of infertility services in the United States: 1995, *Fam Plann Perspect* 32:132,

2000.

24. **Chandra A, Stephen EH**, Infertility service use among U.S. women: 1995 and 2002, *Fertil Steril* 93:725, 2010.
25. Key Statistics from the National Survey of Family Growth 2011–2015, [https://www.cdc.gov/nchs/nsfg/key\\_statistics/i.htm#infertilityservices](https://www.cdc.gov/nchs/nsfg/key_statistics/i.htm#infertilityservices)
26. **Menken J, Trussell J, Larsen U**, Age and infertility, *Science* 233:1389, 1986.
27. **Tietze C**, Reproductive span and rate of reproduction among Hutterite women, *Fertil Steril* 8:89, 1957.
28. **Maroulis GB**, Effect of aging on fertility and pregnancy, *Semin Reprod Endocrinol* 9:165, 1991.
29. **van Noord-Zaadstra BM, Looman CW, Alsbach H, Habbena JDF, te Velde ER, Karbaat J**, Delaying child-bearing: effect of age on fecundity and outcome of pregnancy, *Br Med J* 302:1361, 1991.
30. **Schwartz D, Mayaux MJ**, Female fecundity as a function of age: results of artificial insemination in 2193 nulliparous women with azoospermic husbands. *Federation CECOS, N Engl J Med* 306:404, 1982.
31. **Virro MS, Shewchuk AB**, Pregnancy outcome in 242 conceptions after artificial insemination with donor sperm and effects of maternal age on the prognosis for successful pregnancy, *Am J Obstet Gynecol* 148:518, 1984.
32. **Shenfield F, Doyle P, Valentine A, Steele SJ, Tan S-L**, Effects of age, gravidity and male infertility status on cumulative conception rates following artificial insemination with cryopreserved donor semen: analysis of 2998 cycles of treatment in one centre over 10 years, *Hum Reprod* 8:60, 1993.
33. **Centers for Disease Control and Prevention, American Society for Reproductive Medicine, Society for Assisted Reproductive Technology**, 2015 Assisted Reproductive Technology National Summary Report, US Dept of Health and Human Services, Atlanta, GA, 2017.
34. **Stein ZA**, A woman's age: childbearing and child rearing, *Am J Epidemiol* 121:327, 1985.
35. **Hassold T, Chiu D**, Maternal age-specific rates of numerical chromosome abnormalities with special reference to trisomy, *Hum Genet* 70:11, 1985.
36. **Warburton D, Kline J, Stein Z, Strobino B**, Cytogenetic abnormalities in spontaneous abortions of recognized conceptions, In: Porter IH, ed. *Perinatal Genetics: Diagnosis and Treatment*, Academic Press, New York, 1986.
37. **Gosden RG**, Maternal age: a major factor affecting the prospects and outcome of pregnancy, *Ann N Y Acad Sci* 442:45, 1985.
38. **Wilcox AJ, Weiberg CR, O'Connor JF, Baird DD, Schlatterer JP, Canfield RE, Armstrong EG, Nisula BC**, Incidence of early loss of pregnancy, *N Engl J Med* 319:189, 1988.
39. **Zinaman MJ, Clegg ED, Brown CC, O'Connor J, Selevan SG**, Estimates of human fertility and pregnancy loss, *Fertil Steril* 65:503, 1996.
40. **Warburton D**, Reproductive loss: how much is preventable? *N Engl J Med* 316:158, 1987.
41. **Block E**, Quantitative morphological investigations of the follicular system in women, *Acta Anat* 14:108, 1952.
42. **Block E**, A quantitative morphological investigation of the follicular system in newborn female infants, *Acta Anat (Basel)* 17:201, 1953.
43. **Baker TG**, A quantitative and cytological study of germ cells in human ovaries, *Proc R Soc Lond B Biol Sci* 158:417, 1963.
44. **Vaskivuo TE, Anttonen M, Herva R, Billig H, Dorland M, te Velde ER, Stenback F, Heikinheimo M, Tapanainen JS**, Survival of human ovarian follicles from fetal to adult life: apoptosis, apoptosis-related proteins, and transcription factor GATA-4, *J Clin Endocrinol Metab* 86:3421, 2001.
45. **Markstrom E, Svensson E, Shao R, Svanberg B, Billig H**, Survival factors regulating ovarian apoptosis—dependence on follicle differentiation, *Reproduction* 123:23, 2002.
46. **te Velde ER, Pearson PL**, The variability of female reproductive ageing, *Hum Reprod Update* 8:141, 2002.
47. **Richardson SJ, Senikas V, Nelson JF**, Follicular depletion during the menopausal transition: evidence for accelerated loss and ultimate exhaustion, *J Clin Endocrinol Metab* 65:1231, 1987.
48. **Faddy MJ, Gosden RG**, A model conforming the decline in follicle numbers to the age of menopause in women, *Hum Reprod* 11:1484, 1996.
49. **Battaglia DE, Goodwin P, Klein NA, Soules MR**, Influence of maternal age on meiotic spindle assembly in oocytes from naturally cycling women, *Hum Reprod* 11:2217, 1996.

50. **Gougeon A, Echochard R, Thalabard JC**, Age-related changes of the population of human ovarian follicles: increase in the disappearance rate of non-growing and early-growing follicles in aging women, *Biol Reprod* 50:653, 1994.
51. **Coxworth JE, Hawkes K**, Ovarian follicle loss in humans and mice: lessons from statistical model comparison, *Hum Reprod* 25(7):1796, 2010.
52. **Gougeon A, Chainy GB**, Morphometric studies of small follicles in ovaries of women at different ages, *J Reprod Fertil* 81:433, 1987.
53. **Faddy MJ, Gosden RG, Gougeon A, Richardson SJ, Nelson JF**, Accelerated disappearance of ovarian follicles in mid-life: implications for forecasting menopause, *Hum Reprod* 7:1342, 1992.
54. **Kirkwood TB**, Ovarian ageing and the general biology of senescence, *Maturitas* 30:105, 1998.
55. **Leidy LE, Godfrey LR, Sutherland MR**, Is follicular atresia biphasic? *Fertil Steril* 70:851, 1998.
56. **Cant MA, Johnstone RA**, Reproductive conflict and the separation of reproductive generations in humans, *Proc Natl Acad Sci U S A* 105:5332, 2008.
57. **Tilly JL, Telfer EE**, Purification of germline stem cells from adult mammalian ovaries: a step closer towards control of the female biological clock? *Mol Hum Reprod* 15:393, 2009.
58. **Faddy MJ**, Follicle dynamics during ovarian ageing, *Mol Cell Endocrinol* 163:43, 2000.
59. **Hansen KR, Knowlton NS, Thyer AC, Charleston JS, Soules MR, Klein NA**, A new model of reproductive aging: the decline in ovarian non-growing follicle number from birth to menopause, *Hum Reprod* 23:699, 2008.
60. **Da Silva-Buttkus P, Marcelli G, Franks S, Stark J, Hardy K**, Inferring biological mechanisms from spatial analysis: prediction of a local inhibitor in the ovary, *Proc Natl Acad Sci U S A* 106:456, 2009.
61. **Nilsson E, Rogers N, Skinner MK**, Actions of anti-Mullerian hormone on the ovarian transcriptome to inhibit primordial to primary follicle transition, *Reproduction* 134:209, 2007.
62. **Adhikari D, Liu K**, Molecular mechanisms underlying the activation of mammalian primordial follicles, *Endocr Rev* 30:438, 2009.
63. **Klein NA, Battaglia DE, Fujimoto VY, Davis GS, Bremner WJ, Soules MR**, Reproductive aging: accelerated ovarian follicular development associated with a monotropic follicle-stimulating hormone rise in normal older women, *J Clin Endocrinol Metab* 81:1038, 1996.
64. **Burger HG, Dudley EC, Hopper JL, Groome N, Guthrie JR, Green A, Dennerstein L**, Prospectively measured levels of serum follicle-stimulating hormone, estradiol, and the dimeric inhibins during the menopausal transition in a population-based cohort of women, *J Clin Endocrinol Metab* 84:4025, 1999.
65. **Wise PM, Smith MJ, Dubal DB, Wilson ME, Rau SW, Cashion AB, Bottner M, Rosewell KL**, Neuroendocrine modulation and repercussions of female reproductive aging, *Recent Prog Horm Res* 57:235, 2002.
66. **Bellino FL, Wise PM**, Nonhuman primate models of menopause workshop, *Biol Reprod* 68:10, 2003.
67. **Rehman HU, Masson EA**, Neuroendocrinology of female aging, *Gend Med* 2:41, 2005.
68. **Yin W, Gore AC**, Neuroendocrine control of reproductive aging: roles of GnRH neurons, *Reproduction* 131:403, 2006.
69. **Nozaki M, Mitsunaga F, Shimizu K**, Reproductive senescence in female Japanese monkeys (*Macaca fuscata*): age- and season-related changes in hypothalamic-pituitary-ovarian functions and fecundity rates, *Biol Reprod* 52:1250, 1995.
70. **van Look PF, Lothian H, Hunter WM, Michie EA, Baird DT**, Hypothalamic-pituitary-ovarian function in perimenopausal women, *Clin Endocrinol (Oxf)* 7:13, 1977.
71. **Weiss G, Skurnick JH, Goldsmith LT, Santoro NF, Park SJ**, Menopause and hypothalamic-pituitary sensitivity to estrogen, *JAMA* 292:2991, 2004.
72. **Gill S, Sharpless JL, Rado K, Hall JE**, Evidence that GnRH decreases with gonadal steroid feedback but increases with age in postmenopausal women, *J Clin Endocrinol Metab* 87:2290, 2002.
73. **Hall JE, Lavoie HB, Marsh EE, Martin KA**, Decrease in gonadotropin-releasing hormone (GnRH) pulse frequency with aging in postmenopausal women, *J Clin Endocrinol Metab* 85:1794, 2000.
74. **Rossmannith WG**, Gonadotropin secretion during aging in women: review article, *Exp Gerontol* 30:369, 1995.

75. **Kwekkeboom DJ, de Jong FH, van Hemert AM, Vandenbroucke JP, Valkenburg HA, Lamberts SW**, Serum gonadotropins and alpha-subunit decline in aging normal postmenopausal women, *J Clin Endocrinol Metab* 70:944, 1990.
76. **de Koning CH, Popp-Snijders C, Schoemaker J, Lambalk CB**, Elevated FSH concentrations in imminent ovarian failure are associated with higher FSH and LH pulse amplitude and response to GnRH, *Hum Reprod* 15:1452, 2000.
77. **Matt DW, Kauma SW, Pincus SM, Veldhuis JD, Evans WS**, Characteristics of luteinizing hormone secretion in younger versus older premenopausal women, *Am J Obstet Gynecol* 178:504, 1998.
78. **Klein NA, Battaglia DE, Clifton DK, Bremner WJ, Soules MR**, The gonadotropin secretion pattern in normal women of advanced reproductive age in relation to the monotropic FSH rise, *J Soc Gynecol Investig* 3:27, 1996.
79. **Reame NE, Kelche RP, Beitins IZ, Yu MY, Zawacki CM, Padmanabhan V**, Age effects of follicle-stimulating hormone and pulsatile luteinizing hormone secretion across the menstrual cycle of premenopausal women, *J Clin Endocrinol Metab* 81:1512, 1996.
80. **Randolph JF, Ginsburg KA, Leach RE, Blacker CM, Moghissi KS, Diamond MP, Reame NE**, Elevated early follicular gonadotropin levels in women with unexplained infertility do not provide evidence for disordered gonadotropin-releasing hormone secretion as assessed by luteinizing hormone pulse characteristics, *Fertil Steril* 80:320, 2003.
81. **Eshkol A, Lunenfeld B, Insler V**, The effect of sex steroids on pituitary responsiveness to gonadotropin releasing hormone, *J Steroid Biochem* 6:1061, 1975.
82. **Fujimoto VY, Klein NA, Battaglia DE, Bremner WJ, Soules MR**, The anterior pituitary response to a gonadotropin-releasing hormone challenge test in normal older reproductive-age women, *Fertil Steril* 65:539, 1996.
83. **Klein NA, Battaglia DE, Miller PB, Branigan EF, Giudice LC, Soules MR**, Ovarian follicular development and the follicular fluid hormones and growth factors in normal women of advanced reproductive age, *J Clin Endocrinol Metab* 81:1946, 1996.
84. **Hofmann GE, Danforth DR, Seifer DB**, Inhibin-B: the physiologic basis of the clomiphene citrate challenge test for ovarian reserve screening, *Fertil Steril* 69:474, 1998.
85. **Welt CK, McNicholl DJ, Taylor AE, Hall JE**, Female reproductive aging is marked by decreased secretion of dimeric inhibin, *J Clin Endocrinol Metab* 84:105, 1999.
86. **Seifer DB, Scott RT Jr, Bergh PA, Abrogast LK, Friedman CI, Mack CK, Danforth DR**, Women with declining ovarian reserve may demonstrate a decrease in day 3 serum inhibin B before a rise in day 3 follicle-stimulating hormone, *Fertil Steril* 72:63, 1999.
87. **Klein NA, Houmard BS, Hansen KR, Woodruff TK, Sluss PM, Bremner WJ, Soules MR**, Age-related analysis of inhibin A, inhibin B, and activin a relative to the intercycle monotropic follicle-stimulating hormone rise in normal ovulatory women, *J Clin Endocrinol Metab* 89:2977, 2004.
88. **Hale GE, Zhao X, Hughes CL, Burger HG, Robertson DM, Fraser IS**, Endocrine features of menstrual cycles in middle and late reproductive age and the menopausal transition classified according to the Staging of Reproductive Aging Workshop (STRAW) staging system, *J Clin Endocrinol Metab* 92:3060, 2007.
89. **Knauff EA, Eijkemans MJ, Lambalk CB, ten Kate-Booij MJ, Hoek A, Beerendonk CC, Laven JS, Goverde AJ, Broekmans FJ, Themmen AP, de Jong FH, Fauser BC**, Anti-Mullerian hormone, inhibin B, and antral follicle count in young women with ovarian failure, *J Clin Endocrinol Metab* 94:786, 2009.
90. **Burger HG, Hale GE, Dennerstein L, Robertson DM**, Cycle and hormone changes during perimenopause: the key role of ovarian function, *Menopause* 15:603, 2008.
91. **Welt CK, Smith ZA, Pauler DK, Hall JE**, Differential regulation of inhibin A and inhibin B by luteinizing hormone, follicle-stimulating hormone, and stage of follicle development, *J Clin Endocrinol Metab* 86:2531, 2001.
92. **Burger HG, Dudley EC, Hopper JL, Shelley JM, Green A, Smith A, Dennerstein L, Morse C**, The endocrinology of the menopausal transition: a cross-sectional study of a population-based sample, *J Clin Endocrinol Metab* 80:3537, 1995.

93. **Burger HG, Groome NP, Robertson DM**, Both inhibin A and B respond to exogenous follicle-stimulating hormone in the follicular phase of the human menstrual cycle, *J Clin Endocrinol Metab* 83:4167, 1998.
94. **Landgren BM, Collins A, Csemiczky G, Burger HG, Baksheev L, Robertson DM**, Menopause transition: annual changes in serum hormonal patterns over the menstrual cycle in women during a nine-year period prior to menopause, *J Clin Endocrinol Metab* 89:2763, 2004.
95. **Seifer DB, Gardiner AC, Ferreira KA, Peluso JJ**, Apoptosis as a function of ovarian reserve in women undergoing in vitro fertilization, *Fertil Steril* 66:593, 1996.
96. **Santoro N, Brown JR, Adel T, Skurnick JH**, Characterization of reproductive hormonal dynamics in the perimenopause, *J Clin Endocrinol Metab* 81:1495, 1996.
97. **Shideler SE, DeVane GW, Kalra PS, Benirschke K, Lasley BL**, Ovarian-pituitary hormone interactions during the perimenopause, *Maturitas* 11:331, 1989.
98. **de Koning CH, McDonnell J, Themmen AP, de Jong FH, Homburg R, Lambalk CB**, The endocrine and follicular growth dynamics throughout the menstrual cycle in women with consistently or variably elevated early follicular phase FSH compared with controls, *Hum Reprod* 23:1416, 2008.
99. **Miro F, Parker SW, Aspinnall LJ, Coley J, Perry PW, Ellis JE**, Sequential classification of endocrine stages during reproductive aging in women: the FREEDOM study, *Menopause* 12:281, 2005.
100. **Mersereau JE, Evans ML, Moore DH, Liu JH, Thomas MA, Rebar RW, Pennington E, Cedars MI**, Luteal phase estrogen is decreased in regularly menstruating older women compared with a reference population of younger women, *Menopause* 15:482, 2008.
101. **Pal L, Zhang K, Zeitlian G, Santoro N**, Characterizing the reproductive hormone milieu in infertile women with diminished ovarian reserve, *Fertil Steril* 93:1074, 2010.
102. **Burger H**, The menopausal transition—endocrinology, *J Sex Med* 5:2266, 2008.
103. **Treloar AE, Boynton RE, Borghild GB, Brown BW**, Variation of the human menstrual cycle through reproductive life, *Int J Fertil* 12:77, 1967.
104. **Klein NA, Harper AJ, Houmard BS, Sluss PM, Soules MR**, Is the short follicular phase in older women secondary to advanced or accelerated dominant follicle development? *J Clin Endocrinol Metab* 87:5746, 2002.
105. **Hansen KR, Thyer AC, Sluss PM, Bremner WJ, Soules MR, Klein NA**, Reproductive ageing and ovarian function: is the early follicular phase FSH rise necessary to maintain adequate secretory function in older ovulatory women? *Hum Reprod* 20:89, 2005.
106. **van Zonneveld P, Scheffer GJ, Broekmans FJ, Blankenstein MA, de Jong FH, Looman CW, Habbema JD, te Velde ER**, Do cycle disturbances explain the age-related decline of female fertility? Cycle characteristics of women aged over 40 years compared with a reference population of young women, *Hum Reprod* 18:495, 2003.
107. **Beemsterboer SN, Homburg R, Gorter NA, Schats R, Hompes PG, Lambalk CB**, The paradox of declining fertility but increasing twinning rates with advancing maternal age, *Hum Reprod* 21:1531, 2006.
108. **Lenton EA, Landgren BM, Sexton L**, Normal variation in the length of the luteal phase of the menstrual cycle: identification of the short luteal phase, *Br J Obstet Gynaecol* 91:685, 1984.
109. **Miro F, Aspinnall LJ**, The onset of the initial rise in follicle-stimulating hormone during the human menstrual cycle, *Hum Reprod* 20:96, 2005.
110. **Hoekstra C, Zhao ZZ, Lambalk CB, Willemsen G, Martin NG, Boomsma DI, Montgomery GW**, Dizygotic twinning, *Hum Reprod Update* 14:37, 2008.
111. **Vollman RF**, The menstrual cycle, In: Friedman E, ed. *Major Problems in Obstetrics and Gynecology*, W.B. Saunders Co., Philadelphia, 1977.
112. **Soules MR, Sherman S, Parrott E, Rebar R, Santoro N, Utian W, Woods N**, Executive summary: stages of reproductive aging workshop (STRAW), *Fertil Steril* 76:874, 2001.
113. **den Tonkelaar I, te Velde ER, Looman CW**, Menstrual cycle length preceding menopause in relation to age at menopause, *Maturitas* 29:115, 1998.
114. **Weinstein M, Gorrindo T, Riley A, Mormino J, Niedfeldt J, Singer B, Rodriguez G, Simon J, Pincus S**, Timing of menopause and patterns of menstrual bleeding, *Am J Epidemiol* 158:782, 2003.
115. **Treloar AE**, Menstrual cyclicity and the pre-menopause, *Maturitas* 3:249, 1981.

116. **Lisabeth L, Harlow S, Qaqish B**, A new statistical approach demonstrated menstrual patterns during the menopausal transition did not vary by age at menopause, *J Clin Epidemiol* 57:484, 2004.
117. **Broekmans FJ, Faddy MJ, Scheffer G, te Velde ER**, Antral follicle counts are related to age at natural fertility loss and age at menopause, *Menopause* 11: 607, 2004.
118. **Magursky V, Mesko M, Sokolik L**, Age at the menopause and onset of the climacteric in women of Martin District, Czechoslovakia. Statistical survey and some biological and social correlations, *Int J Fertil* 20:17, 1975.
119. **Bengtsson C, Lindquist O, Redvall L**, Menstrual status and menopausal age of middle-aged Swedish women. A population study of women in Goteborg 1968–69 and 1974–75, *Acta Obstet Gynecol Scand* 60:269, 1981.
120. **Hagstad A, Johansson S, Wilhelmsson C, Janson PO**, Gynaecology of middle-aged women—menstrual and reproductive histories, *Maturitas* 7:99, 1985.
121. **Luoto R, Kaprio J, Uutela A**, Age at natural menopause and sociodemographic status in Finland, *Am J Epidemiol* 139:64, 1994.
122. **van Noord PA, Dubas JS, Dorland M, Boersma H, te Velde E**, Age at natural menopause in a population-based screening cohort: the role of menarche, fecundity, and lifestyle factors, *Fertil Steril* 68:95, 1997.
123. **de Vries E, den Tonkelaar I, van Noord PA, van der Schouw YT, te Velde ER, Peeters PH**, Oral contraceptive use in relation to age at menopause in the DOM cohort, *Hum Reprod* 16:1657, 2001.
124. **Lawlor DA, Ebrahim S, Smith GD**, The association of socio-economic position across the life course and age at menopause: the British Women's Heart and Health Study, *Br J Obstet Gynaecol* 110:1078, 2003.
125. **Cramer DW, Xu H, Harlow BL**, Family history as a predictor of early menopause, *Fertil Steril* 64:740, 1995.
126. **Torgerson DJ, Avenell A, Russell IT, Reid DM**, Factors associated with onset of menopause in women aged 45–49, *Maturitas* 19:83, 1994.
127. **Snieder H, MacGregor AJ, Spector TD**, Genes control the cessation of a woman's reproductive life: a twin study of hysterectomy and age at menopause, *J Clin Endocrinol Metab* 83:1875, 1998.
128. **Treloar SA, Do KA, Martin NG**, Genetic influences on the age at menopause, *Lancet* 352:1084, 1998.
129. **de Bruin JP, Bovenhuis H, van Noord PA, Pearson PL, van Arendonk JA, te Velde ER, Kuurman WW, Dorland M**, The role of genetic factors in age at natural menopause, *Hum Reprod* 16:2014, 2001.
130. **Thomas F, Renaud F, Benefice E, de Meeus T, Guegan JF**, International variability of ages at menarche and menopause: patterns and main determinants, *Hum Biol* 73:271, 2001.
131. **Parazzini F**, Determinants of age at menopause in women attending menopause clinics in Italy, *Maturitas* 56:280, 2007.
132. **Soares SR, Melo MA**, Cigarette smoking and reproductive function, *Curr Opin Obstet Gynecol* 20:281, 2008.
133. **van Asselt KM, Kok HS, Pearson PL, Dubas JS, Peeters PH, Te Velde ER, van Noord PA**, Heritability of menopausal age in mothers and daughters, *Fertil Steril* 82:1348, 2004.
134. **Murabito JM, Yang Q, Fox C, Wilson PW, Cupples LA**, Heritability of age at natural menopause in the Framingham Heart Study, *J Clin Endocrinol Metab* 90:3427, 2005.
135. **Torgerson DJ, Thomas RE, Reid DM**, Mothers and daughters menopausal ages: is there a link? *Eur J Obstet Gynecol Reprod Biol* 74:63, 1997.
136. **Tibiletti MG, Testa G, Vegetti W, Alagna F, Taborelli M, Dalpra L, Bolis PF, Crosignani PG**, The idiopathic forms of premature menopause and early menopause show the same genetic pattern, *Hum Reprod* 14:2731, 1999.
137. **Vegetti W, Marozzi A, Manfredini E, Testa G, Alagna F, Nicolosi A, Caliarì I, Taborelli M, Tibiletti MG, Dalpra L, Crosignani PG**, Premature ovarian failure, *Mol Cell Endocrinol* 161:53, 2000.
138. **Nikolaou D, Templeton A**, Early ovarian ageing: a hypothesis: detection and clinical relevance, *Hum Reprod* 18:1137, 2003.
139. **Farhi J, Homburg R, Ferber A, Orvieto R, Ben Rafael Z**, Non-response to ovarian stimulation in normogonadotrophic, normogonadal women: a clinical sign of impending onset of ovarian failure pre-empting the rise in basal follicle stimulating hormone levels, *Hum Reprod* 12:241, 1997.
140. **de Boer EJ, den Tonkelaar I, te Velde ER, Burger CW, Klip H, van Leeuwen FE**, A low number of retrieved oocytes at in vitro fertilization treatment is predictive of early menopause, *Fertil Steril* 77:978, 2002.

141. **Lawson R, El-Toukhy T, Kassab A, Taylor A, Braude P, Parsons J, Seed P**, Poor response to ovulation induction is a stronger predictor of early menopause than elevated basal FSH: a life table analysis, *Hum Reprod* 18:527, 2003.
142. **Kok HS, van Asselt KM, van der Schouw YT, Peeters PH, Wijmenga C**, Genetic studies to identify genes underlying menopausal age, *Hum Reprod Update* 11:483, 2005.
143. **Skillern A, Rajkovic A**, Recent developments in identifying genetic determinants of premature ovarian failure, *Sex Dev* 2:228, 2008.
144. **Guzeloglu-Kayisli O, Lalioti MD, Sasson I, Aydiner F, Sakkas D, Seli E**, Embryonic poly(A) binding protein (EPAB) is required for oocyte maturation and female fertility in mouse, *Biochem J* 446:47, 2012.
145. **Esencan E, Kallen A, Zhang M, Seli E**, Translational activation of maternally-derived mRNAs in oocytes and early embryos and the role of embryonic poly(A) binding protein (EPAB), *Biol Reprod*, 2019 Feb 26. pii: ioz034. doi: 10.1093/biolre/ioz034.
146. **Knauff EA, Franke L, van Es MA, van den Berg LH, van der Schouw YT, Laven JS, Lambalk CB, Hoek A, Goverde AJ, Christin-Maitre S, Hsueh AJ, Wijmenga C, Fauser BC**, Genome-wide association study in premature ovarian failure patients suggests ADAMTS19 as a possible candidate gene, *Hum Reprod* 24:2372, 2009.
147. **Laisue P, Lakhali B, Benayoun BA, Dipietromaria A, Braham R, Elghezal H, Philibert P, Saad A, Sultan C, Fellous M, Veitia RA**, Functional evidence implicating FOXL2 in non-syndromic premature ovarian failure and in the regulation of the transcription factor OSR2, *J Med Genet* 46:455, 2009.
148. **Kevenaar ME, Themmen AP, Rivadeneira F, Uitterlinden AG, Laven JS, van Schoor NM, Lips P, Pols HA, Visser JA**, A polymorphism in the AMH type II receptor gene is associated with age at menopause in interaction with parity, *Hum Reprod* 22:2382, 2007.
149. **He C, Kraft P, Chen C, Buring JE, Paré G, Hankinson SE, Chanock SJ, Ridker PM, Hunter DJ, Chasman DI**, Genome-wide association studies identify loci associated with age at menarche and age at natural menopause. *Nat Genet* 41:724, 2009.
150. **Stolk L, Zhai G, van Meurs JB, Verbiest MM, Visser JA, Estrada K, Rivadeneira F, Williams FM, Cherkas L, Deloukas P, Soranzo N, de Keyzer JJ, Pop VJ, Lips P, Lebrun CE, van der Schouw YT, Grobbee DE, Witteman J, Hofman A, Pols HA, Laven JS, Spector TD, Uitterlinden AG**, Loci at chromosomes 13, 19 and 20 influence age at natural menopause, *Nat Genet* 41:645, 2009.
151. **Chen CT, Liu CT, Chen GK, Andrews JS, Arnold AM, Dreyfus J, Franceschini N, Garcia ME, Kerr KF, Li G, Lohman KK, Musani SK, Nalls MA, Raffel LJ, Smith J, Ambrosone CB, Bandera EV, Bernstein L, Britton A, Brzyski RG, Cappola A, Carlson CS, Couper D, Deming SL, Goodarzi MO, Heiss G, John EM, Lu X, Le Marchand L, Marciante K, Mcknight B, Millikan R, Nock NL, Olshan AF, Press MF, Vaidya D, Woods NF, Taylor HA, Zhao W, Zheng W, Evans MK, Harris TB, Henderson BE, Kardina SL, Kooperberg C, Liu Y, Mosley TH, Psaty B, Wellons M, Windham BG, Zonderman AB, Cupples LA, Demerath EW, Haiman C, Murabito JM, Rajkovic A**, Meta-analysis of loci associated with age at natural menopause in African-American women, *Hum Mol Genet* 23:3327, 2014.
152. **Shen C, Delahanty RJ, Gao YT, Shen C, Delahanty RJ, Gao YT, Lu W, Xiang YB, Zheng Y, Cai Q, Zheng W, Shu XO, Long J**, Evaluating GWAS-identified SNPs for age at natural menopause among Chinese women, *PLoS One* 8:e58766, 2013.
153. **Murray A, Bennett CE, Perry JR, Weedon MN, Jacobs PA, Morris DH, Orr N, Schoemaker MJ, Jones M, Ashworth A, Swerdlow AJ; ReproGen Consortium**, Common genetic variants are significant risk factors for early menopause: results from the Breakthrough Generations Study, *Hum Mol Genet* 20:186, 2011.
154. **Stolk L, Perry JR, Chasman DI, He C, Mangino M, Sulem P, Barbalic M, Broer L, Byrne EM, Ernst F, Esko T, Franceschini N, Gudbjartsson DF, Hottenga JJ, Kraft P, McArdle PF, Porcu E, Shin SY, Smith AV, van Wingerden S, Zhai G, Zhuang WV, Albrecht E, Alizadeh BZ, Aspelund T, Bandinelli S, Lauc LB, Beckmann JS, Boban M, Boerwinkle E, Broekmans FJ, Burri A, Campbell H, Chanock SJ, Chen C, Cornelis MC, Corre T, Coviello AD, d'Adamo P, Davies G, de Faire U, de Geus EJ,**

Deary IJ, Dedoussis GV, Deloukas P, Ebrahim S, Eiriksdottir G, Emilsson V, Eriksson JG, Fauser BC, Ferreli L, Ferrucci L, Fischer K, Folsom AR, Garcia ME, Gasparini P, Gieger C, Glazer N, Grobbee DE, Hall P, Haller T, Hankinson SE, Hass M, Hayward C, Heath AC, Hofman A, Ingelsson E, Janssens AC, Johnson AD, Karasik D, Kardina SL, Keyzer J, Kiel DP, Kolcic I, Kutalik Z, Lahti J, Lai S, Laisk T, Laven JS, Lawlor DA, Liu J, Lopez LM, Louwers YV, Magnusson PK, Marongiu M, Martin NG, Klaric IM, Masciullo C, McKnight B, Medland SE, Melzer D, Mooser V, Navarro P, Newman AB, Nyholt DR, Onland-Moret NC, Palotie A, Paré G, Parker AN, Pedersen NL, Peeters PH, Pistis G, Plump AS, Polasek O, Pop VJ, Psaty BM, Rääkkönen K, Rehnberg E, Rotter JI, Rudan I, Sala C, Salumets A, Scuteri A, Singleton A, Smith JA, Snieder H, Soranzo N, Stacey SN, Starr JM, Stathopoulou MG, Stirrups K, Stolk RP, Stykarsdottir U, Sun YV, Tenesa A, Thorand B, Toniolo D, Tryggvadottir L, Tsui K, Ulivi S, van Dam RM, van der Schouw YT, van Gils CH, van Nierop P, Vink JM, Visscher PM, Voorhuis M, Waeber G, Wallaschofski H, Wichmann HE, Widen E, Wijnands-van Gent CJ, Willemsen G, Wilson JF, Wolfenbittel BH, Wright AF, Yerges-Armstrong LM, Zemunik T, Zgaga L, Zillikens MC, Zygmont M; LifeLines Cohort Study, Arnold AM, Boomsma DI, Buring JE, Crisponi L, Demerath EW, Gudnason V, Harris TB, Hu FB, Hunter DJ, Launer LJ, Metspalu A, Montgomery GW, Oostra BA, Ridker PM, Sanna S, Schlessinger D, Spector TD, Stefansson K, Streeten EA, Thorsteinsdottir U, Uda M, Uitterlinden AG, van Duijn CM, Völzke H, Murray A, Murabito JM, Visser JA, Lunetta KL, Meta-analyses identify 13 loci associated with age at menopause and highlight DNA repair and immune pathways. *Nat Genet* 44:260, 2012.

155. **AlAsiri S, Basit S, Wood-Trageser MA, Yatsenko SA, Jeffries EP, Surti U, Ketterer DM, Afzal S, Ramzan K, Faiyaz-Ul Haque M, Jiang H, Trakselis MA, Rajkovic A**, Exome sequencing reveals MCM8 mutation underlies ovarian failure and chromosomal instability, *J Clin Invest* 125(1):258, 2015.
156. **Desai S, Wood-Trageser M, Matic J, Chipkin J, Jiang H, Bachelot A, Dulon J, Sala C, Barbieri C, Cocca M, Toniolo D, Touraine P, Witchel S, Rajkovic A**, MCM8 and MCM9 nucleotide variants in women with primary ovarian insufficiency, *J Clin Endocrinol Metab* 102:576, 2017.
157. **Jacobs SL, Metzger DA, Dodson WC, Haney AF**, Effect of age on response to human menopausal gonadotropin stimulation, *J Clin Endocrinol Metab* 71:1525, 1990.
158. **Piltonen T, Koivunen R, Ruokonen A, Tapanainen JS**, Ovarian age-related responsiveness to human chorionic gonadotropin, *J Clin Endocrinol Metab* 88:3327, 2003.
159. **Kuliev A, Cieslak J, Verlinsky Y**, Frequency and distribution of chromosome abnormalities in human oocytes, *Cytogenet Genome Res* 111:193, 2005.
160. **Hunt PA, Hassold TJ**, Human female meiosis: what makes a good egg go bad? *Trends Genet* 24:86, 2008.
161. **Pellestor F, Anahory T, Hamamah S**, Effect of maternal age on the frequency of cytogenetic abnormalities in human oocytes, *Cytogenet Genome Res* 111:206, 2005.
162. **Pellestor F, Andreo B, Arnal F, Humeau C, Demaille J**, Maternal aging and chromosomal abnormalities: new data drawn from in vitro unfertilized human oocytes, *Hum Genet* 112:195, 2003.
163. **Pellestor F, Andreo B, Anahory T, Hamamah S**, The occurrence of aneuploidy in human: lessons from the cytogenetic studies of human oocytes, *Eur J Med Genet* 49:103, 2006.
164. **Angell R**, First-meiotic-division nondisjunction in human oocytes, *Am J Hum Genet* 61:23, 1997.
165. **Angell R**, Mechanism of chromosome nondisjunction in human oocytes, *Prog Clin Biol Res* 393:13, 1995.
166. **Kuliev A, Cieslak J, Ilkevitch Y, Verlinsky Y**, Chromosomal abnormalities in a series of 6,733 human oocytes in preimplantation diagnosis for age-related aneuploidies, *Reprod Biomed Online* 6:54, 2003.
167. **Geraedts J, Montag M, Magli MC, Repping S, Handyside A, Staessen C, Harper J, Schmutzler A, Collins J, Goossens V, van der Ven H, Vesela K, Gianaroli L**, Polar body array CGH for prediction of the status of the corresponding oocyte. Part I: clinical results, *Hum Reprod* 26:3173, 2011.
168. **Franasiak JM, Forman EJ, Hong KH, Werner MD, Upham KM, Treff NR, Scott RT**, Aneuploidy across individual chromosomes at the embryonic level in trophoctoderm biopsies: changes with patient age and chromosome structure, *J Assist Reprod Genet* 31:1501, 2014.
169. **Lamb NE, Feingold E, Savage A, Avramopoulos D, Freeman S, Gu Y, Hallberg A, Hersey J**,



- Karadima G, Pettay D, Saker D, Shen J, Taft L, Mikkelsen M, Petersen MB, Hassold T, Sherman SL**, Characterization of susceptible chiasma configurations that increase the risk for maternal nondisjunction of chromosome 21, *Hum Mol Genet* 6:1391, 1997.
170. **Lamb NE, Freeman SB, Savage-Austin A, Pettay D, Taft L, Hersey J, Gu Y, Shen J, Saker D, May KM, Avramopoulos D, Petersen MB, Hallberg A, Mikkelsen M, Hassold TJ, Sherman SL**, Susceptible chiasmate configurations of chromosome 21 predispose to non-disjunction in both maternal meiosis I and meiosis II, *Nat Genet* 14:400, 1996.
171. **Nasmyth K**, Disseminating the genome: joining, resolving, and separating sister chromatids during mitosis and meiosis, *Annu Rev Genet* 35:673, 2001.
172. **Michaelis C, Ciosk R, Nasmyth K**, Cohesins: chromosomal proteins that prevent premature separation of sister chromatids, *Cell* 91:35, 1997.
173. **Nicklas BJ, Toth MJ, Goldberg AP, Poehlman ET**, Racial differences in plasma leptin concentrations in obese postmenopausal women, *J Clin Endocrinol Metab* 82:315, 1997.
174. **Nicklas RB**, How cells get the right chromosomes, *Science* 275:632, 1997.
175. **Nasmyth K, Peters JM, Uhlmann F**, Splitting the chromosome: cutting the ties that bind sister chromatids, *Science* 288:1379, 2000.
176. **Mahmood R, Brierley CH, Faed MJ, Mills JA, Delhanty JD**, Mechanisms of maternal aneuploidy: FISH analysis of oocytes and polar bodies in patients undergoing assisted conception, *Hum Genet* 106:620, 2000.
177. **Sandalinas M, Marquez C, Munne S**, Spectral karyotyping of fresh, non-inseminated oocytes, *Mol Hum Reprod* 8:580, 2002.
178. **Volarcik K, Sheean L, Goldfarb J, Woods L, Abdul-Karim FW, Hunt P**, The meiotic competence of in-vitro matured human oocytes is influenced by donor age: evidence that folliculogenesis is compromised in the reproductively aged ovary, *Hum Reprod* 13:154, 1998.
179. **Nagele F, O'Connor H, Davies A, Badawy A, Mohamed H, Magos A**, 2500 Outpatient diagnostic hysteroscopies, *Obstet Gynecol* 88:87, 1996.
180. **Day Baird D, Dunson DB, Hill MC, Cousins D, Schectman JM**, High cumulative incidence of uterine leiomyoma in black and white women: ultrasound evidence, *Am J Obstet Gynecol* 188:100, 2003.
181. **De Waay DJ, Syrop CH, Nygaard IE, Davis WA, Van Voorhis BJ**, Natural history of uterine polyps and leiomyomata, *Obstet Gynecol* 100:3, 2002.
182. **Donnez J, Jadoul P**, What are the implications of myomas on fertility? A need for a debate? *Hum Reprod* 17:1424, 2002.
183. **Olive DL, Pritts EA**, Fibroids and reproduction, *Semin Reprod Med* 28(3):218, 2010.
184. **Varasteh NN, Neuwirth RS, Levin B, Keltz MD**, Pregnancy rates after hysteroscopic polypectomy and myomectomy in infertile women, *Obstet Gynecol* 94:168, 1999.
185. **Mastrominas M, Pistofidis GA, Dimitropoulos K**, Fertility outcome after outpatient hysteroscopic removal of endometrial polyps and submucous fibroids, *J Am Assoc Gynecol Laparosc* 3:S29, 1996.
186. **Noci I, Borri P, Chieffi O, Scarselli G, Biagiotti R, Moncini D, Paglierani M, Taddei G**, I. Aging of the human endometrium: a basic morphological and immunohistochemical study, *Eur J Obstet Gynecol Reprod Biol* 63:181, 1995.
187. **Yaron Y, Botchan A, Amit A, Kogosowski A, Yovel I, Lessing JB**, Endometrial receptivity: the age-related decline in pregnancy rates and the effect of ovarian function, *Fertil Steril* 60:314, 1993.
188. **Meldrum DR**, Female reproductive aging—ovarian and uterine factors, *Fertil Steril* 59:1, 1993.
189. **Pellicer A, Simon C, Remohi J**, Effects of aging on the female reproductive system, *Hum Reprod* 10(Suppl 2):77, 1995.
190. **Centers for Disease Control and Prevention**, 2007 assisted reproductive technology success rates, National Summary and Fertility Clinic Reports, Atlanta, GA, 2009.
191. **Sauer MV, Paulson RJ, Lobo RA**, Pregnancy in women 50 or more years of age: outcomes of 22 consecutively established pregnancies from oocyte donation, *Fertil Steril* 64:11, 1995.
192. **Abdalla HI, Burton G, Kirkland A, Johnson MR, Leonard T, Brooks AA, Studd JW**, Age, pregnancy and miscarriage: uterine versus ovarian factors, *Hum Reprod* 8:1512, 1993.

193. **Taylor HS**, Role of the uterus in fertility, pregnancy, and developmental programming, *Fertil Steril* 110(5):849, 2018.
194. **Segal TR, Kim K, Mumford SL, Goldfarb JM, Weinerman RS**, How much does the uterus matter? Perinatal outcomes are improved when donor oocyte embryos are transferred to gestational carriers compared to intended parent recipients *Fertil Steril* 110:888, 2018.
195. **Kidd SA, Eskenazi B, Wyrobek AJ**, Effects of male age on semen quality and fertility: a review of the literature, *Fertil Steril* 75:237, 2001.
196. **Eskenazi B, Wyrobek AJ, Slotter E, Kidd SA, Moore L, Young S, Moore D**, The association of age and semen quality in healthy men, *Hum Reprod* 18(2):447, 2003.
197. **Kumar N, Singh AK, Choudhari AR**, Impact of age on semen parameters in male partners of infertile couples in a rural tertiary care center of central India: a cross-sectional study, *Int J Reprod Biomed (Yazd)*, 15(8):497, 2017.
198. **Girsh E, Katz N, Genkin L, Girtler O, Bocker J, Bezdin S, Barr I**. Male age influences oocyte-donor program results, *J Assist Reprod Genet* 25(4):137, 2008.
199. **Nankin HR**, Fertility in aging men, *Maturitas* 7:259, 1985.
200. **Bujan L, Mieusset R, Mondinat C, Mansat A, Pontonnier F**, Sperm morphology in fertile men and its age related variation, *Andrologia* 20:121, 1988.
201. **Rolf C, Behre HM, Nieschlag E**, Reproductive parameters of older compared to younger men of infertile couples, *Int J Androl* 19:135, 1996.
202. **Chia SE, Lim ST, Tay SK**, Factors associated with male infertility: a case-control study of 218 infertile and 240 fertile men, *Br J Obstet Gynaecol* 107:55, 2000.
203. **Tennekoon KH, Karunanayake EH, Serum FSH, LH, and testosterone concentrations in presumably fertile men: effect of age**, *Int J Fertil* 38:108, 1993.
204. **Vermeulen A, Kaufman JM**, Ageing of the hypothalamo-pituitary-testicular axis in men, *Horm Res* 43:25, 1995.
205. **Hassan MA, Killick SR**, Effect of male age on fertility: evidence for the decline in male fertility with increasing age, *Fertil Steril* 79(Suppl 3):1520, 2003.
206. **Faber BM, Mercan R, Hamacher P, Muasher SJ, Toner JP**, The impact of an egg donor's age and her prior fertility on recipient pregnancy outcome, *Fertil Steril* 68:370, 1997.
207. **Dunson DB, Colombo B, Baird DD**, Changes with age in the level and duration of fertility in the menstrual cycle, *Hum Reprod* 17:1399, 2002.
208. **Paulson RJ, Milligan RC, Sokol RZ**, The lack of influence of age on male fertility, *Am J Obstet Gynecol* 184(5):818; discussion 822–824, 2001.
209. **Egozcue J, Blanco J, Anton E, Egozcue S, Sarrate Z, Vidal F**, Genetic analysis of sperm and implications of severe male infertility—a review, *Placenta* 24(Suppl 2): S62, 2003.
210. **Slama R, Werwatz A, Boutou O, Ducot B, Spira A, Hardle W**, Does male age affect the risk of spontaneous abortion? An approach using semiparametric regression, *Am J Epidemiol* 157:815, 2003.
211. **Jenkins TG, Aston KI, Pflueger C, Cairns BR, Carrell DT**, Age-associated sperm DNA methylation alterations: possible implications in offspring disease susceptibility, *Plos Genet* 10:e1004458, 2014.
212. **Zumoff B, Strain GW, Kream J, O'Connor J, Rosenfeld RS, Levin J, Fukushima DK**, Age variation of the 24-hour mean plasma concentrations of androgens, estrogens, and gonadotropins in normal adult men, *J Clin Endocrinol Metab* 54:534, 1982.
213. **Veldhuis JD**, Recent insights into neuroendocrine mechanisms of aging of the human male hypothalamic-pituitary-gonadal axis, *J Androl* 20:1, 1999.
214. **Hermann M, Untergasser G, Rumpold H, Berger P**, Aging of the male reproductive system, *Exp Gerontol* 35:1267, 2000.
215. **Muasher SJ, Oehninger S, Simonetti S, Matta J, Ellis LM, Liu HC, Jones GS, Rosenwaks Z**, The value of basal and/or stimulated serum gonadotropin levels in prediction of stimulation response and in vitro fertilization outcome, *Fertil Steril* 50:298, 1988.
216. **Scott RT, Toner JP, Muasher SJ, Oehninger S, Robinson S, Rosenwaks Z**, Follicle-stimulating hormone

levels on cycle day 3 are predictive of in vitro fertilization outcome, *Fertil Steril* 51:651, 1989.

217. **Toner JP, Philput CB, Jones GS, Muasher SJ**, Basal follicle-stimulating hormone level is a better predictor of in vitro fertilization performance than age, *Fertil Steril* 55:784, 1991.
218. **Pearlstone AC, Fournet N, Gambone JC, Pang SC, Buyalos RP**, Ovulation induction in women age 40 and older: the importance of basal follicle-stimulating hormone level and chronological age, *Fertil Steril* 58:674, 1992.
219. **Scott RT Jr, Hofmann GE**, Prognostic assessment of ovarian reserve, *Fertil Steril* 63:1, 1995.
220. **Bukman A, Heineman MJ**, Ovarian reserve testing and the use of prognostic models in patients with subfertility, *Hum Reprod Update* 7:581, 2001.
221. **Barroso G, Oehninger S, Monzo A, Kolm P, Gibbons WE, Muasher SJ**, High FSH:LH ratio and low LH levels in basal cycle day 3: impact on follicular development and IVF outcome, *J Assist Reprod Genet* 18:499, 2001.
222. **Broekmans FJ, Kwee J, Hendriks DJ, Mol BW, Lambalk CB**, A systematic review of tests predicting ovarian reserve and IVF outcome, *Hum Reprod Update* 12:685, 2006.
223. **Roberts JE, Spandorfer S, Fasouliotis SJ, Kashyap S, Rosenwaks Z**, Taking a basal follicle-stimulating hormone history is essential before initiating in vitro fertilization, *Fertil Steril* 83:37, 2005.
224. **Abdalla H, Thum MY**, Repeated testing of basal FSH levels has no predictive value for IVF outcome in women with elevated basal FSH, *Hum Reprod* 21:171, 2006.
225. **Scott RT Jr, Hofmann GE, Oehninger S, Muasher SJ**, Intercycle variability of day 3 follicle-stimulating hormone levels and its effect on stimulation quality in in vitro fertilization, *Fertil Steril* 54:297, 1990.
226. **Hazout A, Bouchard P, Seifer DB, Aussage P, Junca AM, Cohen-Bacrie P**, Serum antimullerian hormone/mullerian-inhibiting substance appears to be a more discriminatory marker of assisted reproductive technology outcome than follicle-stimulating hormone, inhibin B, or estradiol, *Fertil Steril* 82:1323, 2004.
227. **Eldar-Geva T, Ben-Chetrit A, Spitz IM, Rabinowitz R, Markowitz E, Mimoni T, Gal M, Zylber-Haran E, Margalioth EJ**, Dynamic assays of inhibin B, anti-Mullerian hormone and estradiol following FSH stimulation and ovarian ultrasonography as predictors of IVF outcome, *Hum Reprod* 20:3178, 2005.
228. **McIlveen M, Skull JD, Ledger WL**, Evaluation of the utility of multiple endocrine and ultrasound measures of ovarian reserve in the prediction of cycle cancellation in a high-risk IVF population, *Hum Reprod* 22:778, 2007.
229. **Phophong P, Ranieri DM, Khadum I, Meo F, Serhal P**, Basal 17beta-estradiol did not correlate with ovarian response and in vitro fertilization treatment outcome, *Fertil Steril* 74:1133, 2000.
230. **Evers JL, Slaats P, Land JA, Dumoulin JC, Dunselman GA**, Elevated levels of basal estradiol-17beta predict poor response in patients with normal basal levels of follicle-stimulating hormone undergoing in vitro fertilization, *Fertil Steril* 69:1010, 1998.
231. **Smotrich DB, Widra EA, Gindoff PR, Levy MJ, Hall JL, Stillman RJ**, Prognostic value of day 3 estradiol on in vitro fertilization outcome, *Fertil Steril* 64:1136, 1995.
232. **Licciardi FL, Liu HC, Rosenwaks Z**, Day 3 estradiol serum concentrations as prognosticators of ovarian stimulation response and pregnancy outcome in patients undergoing in vitro fertilization, *Fertil Steril* 64:991, 1995.
233. **Buyalos RP, Daneshmand S, Brzechffa PR**, Basal estradiol and follicle-stimulating hormone predict fecundity in women of advanced reproductive age undergoing ovulation induction therapy, *Fertil Steril* 68:272, 1997.
234. **Navot D, Rosenwaks Z, Margalioth EJ**, Prognostic assessment of female fecundity, *Lancet* ii:645, 1987.
235. **Yong PY, Baird DT, Thong KJ, McNeilly AS, Anderson RA**, Prospective analysis of the relationships between the ovarian follicle cohort and basal FSH concentration, the inhibin response to exogenous FSH and ovarian follicle number at different stages of the normal menstrual cycle and after pituitary down-regulation, *Hum Reprod* 18:35, 2003.
236. **Yanushpolsky EH, Hurwitz S, Tikh E, Racowsky C**, Predictive usefulness of cycle day 10 follicle-stimulating hormone level in a clomiphene citrate challenge test for in vitro fertilization outcome in women younger than 40 years of age, *Fertil Steril* 80:111, 2003.

237. **Csemiczky G, Harlin J, Fried G**, Predictive power of clomiphene citrate challenge test for failure of in vitro fertilization treatment, *Acta Obstet Gynecol Scand* 81:954, 2002.
238. **Kwee J, Schats R, McDonnell J, Lambalk CB, Schoemaker J**, Intercycle variability of ovarian reserve tests: results of a prospective randomized study, *Hum Reprod* 19:590, 2004.
239. **Hannoun A, Abu Musa A, Awwad J, Kaspar H, Khalil A**, Clomiphene citrate challenge test: cycle to cycle variability of cycle day 10 follicle stimulating hormone level, *Clin Exp Obstet Gynecol* 25:155, 1998.
240. **Hendriks DJ, Broekmans FJ, Bancsi LF, de Jong FH, Looman CW, Te Velde ER**, Repeated clomiphene citrate challenge testing in the prediction of outcome in IVF: a comparison with basal markers for ovarian reserve, *Hum Reprod* 20:163, 2005.
241. **Hendriks DJ, Mol BW, Bancsi LF, te Velde ER, Broekmans FJ**, The clomiphene citrate challenge test for the prediction of poor ovarian response and nonpregnancy in patients undergoing in vitro fertilization: a systematic review, *Fertil Steril* 86:807, 2006.
242. **Muttukrishna S, McGarrigle H, Wakim R, Khadum I, Ranieri DM, Serhal P**, Antral follicle count, anti-mullerian hormone and inhibin B: predictors of ovarian response in assisted reproductive technology? *Br J Obstet Gynaecol* 112:1384, 2005.
243. **Muttukrishna S, Suharjono H, McGarrigle H, Sathanandan M**, Inhibin B and anti-Mullerian hormone: markers of ovarian response in IVF/ICSI patients? *Br J Obstet Gynaecol* 111:1248, 2004.
244. **Balasch J, Creus M, Fabregues F, Carmona F, Casamitjana R, Ascaso C, Vanrell JA**, Inhibin, follicle-stimulating hormone, and age as predictors of ovarian response in in vitro fertilization cycles stimulated with gonadotropin-releasing hormone agonist-gonadotropin treatment, *Am J Obstet Gynecol* 175: 1226, 1996.
245. **Seifer DB, MacLaughlin DT, Christian BP, Feng B, Sheldon RM**, Early follicular serum mullerian-inhibiting substance levels are associated with ovarian response during assisted reproductive technology cycles, *Fertil Steril* 77:468, 2002.
246. **Hall JE, Welt CK, Cramer DW**, Inhibin A and inhibin B reflect ovarian function in assisted reproduction but are less useful at predicting outcome, *Hum Reprod* 14:409, 1999.
247. **Creus M, Penarrubia J, Fabregues F, Vidal E, Carmona F, Casamitjana R, Vanrell JA, Balasch J**, Day 3 serum inhibin B and FSH and age as predictors of assisted reproduction treatment outcome, *Hum Reprod* 15:2341, 2000.
248. **Smeenk JM, Sweep FC, Zielhuis GA, Kremer JA, Thomas CM, Braat DD**, Antimullerian hormone predicts ovarian responsiveness, but not embryo quality or pregnancy, after in vitro fertilization or intracytoplasmic sperm injection, *Fertil Steril* 87:223, 2007.
249. **Vigier B, Tran D, Legeai L, Bezaud J, Josso N**, Origin of anti-Mullerian hormone in bovine freemartin fetuses, *J Reprod Fertil* 70:473, 1984.
250. **Durlinger AL, Kramer P, Karels B, de Jong FH, Uilenbroek JT, Grootegoed JA, Themmen AP**, Control of primordial follicle recruitment by anti-Mullerian hormone in the mouse ovary, *Endocrinology* 140:5789, 1999.
251. **Durlinger AL, Gruijters MJ, Kramer P, Karels B, Kumar TR, Matzuk MM, Rose UM, de Jong FH, Uilenbroek JT, Grootegoed JA, Themmen AP**, Anti-Mullerian hormone attenuates the effects of FSH on follicle development in the mouse ovary, *Endocrinology* 142:4891, 2001.
252. **Weenen C, Laven JS, Von Bergh AR, Cranfield M, Groome NP, Visser JA, Kramer P, Fauser BC, Themmen AP**, Anti-Mullerian hormone expression pattern in the human ovary: potential implications for initial and cyclic follicle recruitment, *Mol Hum Reprod* 10:77, 2004.
253. **Durlinger AL, Visser JA, Themmen APN**, Regulation of ovarian function: the role of anti-Müllerian hormone, *Reproduction* 124:601, 2002.
254. **Fanchin R, Schonauer LM, Righini C, Frydman N, Frydman R, Taieb J**, Serum anti-Mullerian hormone dynamics during controlled ovarian hyperstimulation, *Hum Reprod* 18:328, 2003.
255. **Catteau-Jonard S, Pigny P, Reyss AC, Decanter C, Poncelet E, Dewailly D**, Changes in serum anti-mullerian hormone level during low-dose recombinant follicular-stimulating hormone therapy for anovulation in polycystic ovary syndrome, *J Clin Endocrinol Metab* 92:4138, 2007.
256. **Kevenaar ME, Meerasahib MF, Kramer P, van de Lang-Born BM, de Jong FH, Groome NP**,

- Themmen AP, Visser JA**, Serum anti-mullerian hormone levels reflect the size of the primordial follicle pool in mice, *Endocrinology* 147:3228, 2006.
257. **Sowers MR, Eyvazzadeh AD, McConnell D, Yosef M, Jannausch ML, Zhang D, Harlow S, Randolph JF Jr**, Anti-mullerian hormone and inhibin B in the definition of ovarian aging and the menopause transition, *J Clin Endocrinol Metab* 93:3478, 2008.
258. **van Rooij IA, Tonkelaar I, Broekmans FJ, Looman CW, Scheffer GJ, de Jong FH, Themmen AP, te Velde ER**, Anti-mullerian hormone is a promising predictor for the occurrence of the menopausal transition, *Menopause* 11:601, 2004.
259. **van Rooij IA, Broekmans FJ, Scheffer GJ, Looman CW, Habbema JD, de Jong FH, Fauser BJ, Themmen AP, te Velde ER**, Serum antimullerian hormone levels best reflect the reproductive decline with age in normal women with proven fertility: a longitudinal study, *Fertil Steril* 83:979, 2005.
260. **de Vet A, Laven JS, de Jong FH, Themmen AP, Fauser BC**, Antimullerian hormone serum levels: a putative marker for ovarian aging, *Fertil Steril* 77:357, 2002.
261. **Fanchin R, Taieb J, Lozano DH, Ducot B, Frydman R, Bouyer J**, High reproducibility of serum anti-Mullerian hormone measurements suggests a multi-staged follicular secretion and strengthens its role in the assessment of ovarian follicular status, *Hum Reprod* 20:923, 2005.
262. **Tsepelidis S, Devreker F, Demeestere I, Flahaut A, Gervy C, Englert Y**, Stable serum levels of anti-Mullerian hormone during the menstrual cycle: a prospective study in normo-ovulatory women, *Hum Reprod* 22:1837, 2007.
263. **Hehenkamp WJ, Looman CW, Themmen AP, de Jong FH, Te Velde ER, Broekmans FJ**, Anti-Mullerian hormone levels in the spontaneous menstrual cycle do not show substantial fluctuation, *J Clin Endocrinol Metab* 91:4057, 2006.
264. **Broer SL, Broekmans FJM, Laven JSE, Fauser BCJM**, Anti-Müllerian hormone: ovarian reserve testing and its potential implications, *Hum Reprod Update* 20:688, 2014.
265. **Freour T, Mirallie S, Bach-Ngohou K, Denis M, Barriere P, Masson D**, Measurement of serum anti-Mullerian hormone by Beckman Coulter ELISA and DSL ELISA: comparison and relevance in assisted reproduction technology (ART), *Clin Chim Acta* 375:162, 2007.
266. **Dorgan JF, Spittle CS, Egleston BL, Shaw CM, Kahle LL, Brinton LA**, Assay reproducibility and within-person variation of Mullerian inhibiting substance, *Fertil Steril* 94:301, 2010.
267. **van Rooij IA, Broekmans FJ, te Velde ER, Fauser BC, Bancsi LF, de Jong FH, Themmen AP**, Serum anti-Mullerian hormone levels: a novel measure of ovarian reserve, *Hum Reprod* 17:3065, 2002.
268. **Silberstein T, MacLaughlin DT, Shai I, Trimarchi JR, Lambert-Messerlian G, Seifer DB, Keefe DL, Blazar AS**, Mullerian inhibiting substance levels at the time of HCG administration in IVF cycles predict both ovarian reserve and embryo morphology, *Hum Reprod* 21:159, 2006.
269. **Ebner T, Sommergruber M, Moser M, Shebl O, Schreier-Lechner E, Tews G**, Basal level of anti-Mullerian hormone is associated with oocyte quality in stimulated cycles, *Hum Reprod* 21:2022, 2006.
270. **Morin SJ, Patounakis G, Juneau CR, Neal SA, Scott RT Jr, Seli E**, Diminished ovarian reserve and poor response to stimulation in patients <38 years old: a quantitative but not qualitative reduction in performance, *Hum Reprod*, 2018. doi: 10.1093/humrep/dey238.
271. **Pacheco A, Cruz M, Iglesias C, García-Velasco JA**, Very low anti-müllerian hormone concentrations are not an independent predictor of embryo quality and pregnancy rate. *Reprod Biomed Online* 37(1):113, 2018.
272. **Ficicioglu C, Kutlu T, Baglam E, Bakacak Z**, Early follicular antimullerian hormone as an indicator of ovarian reserve, *Fertil Steril* 85:592, 2006.
273. **Gnoth C, Schuring AN, Friol K, Tigges J, Mallmann P, Godehardt E**, Relevance of anti-Mullerian hormone measurement in a routine IVF program, *Hum Reprod* 23:1359, 2008.
274. **Penarrubia J, Fabregues F, Manau D, Creus M, Casals G, Casamitjana R, Carmona F, Vanrell JA, Balasch J**, Basal and stimulation day 5 anti-Mullerian hormone serum concentrations as predictors of ovarian response and pregnancy in assisted reproductive technology cycles stimulated with gonadotropin-releasing hormone agonist–gonadotropin treatment, *Hum Reprod* 20:915, 2005.
275. **Gougeon A**, Regulation of ovarian follicular development in primates: facts and hypotheses, *Endocr Rev*

17:121, 1996.

276. **Pache TD, Wladimiroff JW, de Jong FH, Hop WC, Fauser BC**, Growth patterns of nondominant ovarian follicles during the normal menstrual cycle, *Fertil Steril* 54:638, 1990.
277. **Ruess ML, Kline J, Santos R, Levin B, Timor-Tritsch I**, Age and the ovarian follicle pool assessed with transvaginal ultrasonography, *Am J Obstet Gynecol* 174:624, 1996.
278. **Scheffer GJ, Broekmans FJ, Dorland M, Habbema JD, Looman CW, te Velde ER**, Antral follicle counts by transvaginal ultrasonography are related to age in women with proven natural fertility, *Fertil Steril* 72:845, 1999.
279. **Meldrum DR, Chetkowski RJ, Steingold KA, Randle D**, Transvaginal ultrasound scanning of ovarian follicles, *Fertil Steril* 42:803, 1984.
280. **Bancsi LF, Broekmans FJ, Looman CW, Habbema JD, te Velde ER**, Impact of repeated antral follicle counts on the prediction of poor ovarian response in women undergoing in vitro fertilization, *Fertil Steril* 81:35, 2004.
281. **Hansen KR, Morris JL, Thyer AC, Soules MR**, Reproductive aging and variability in the ovarian antral follicle count: application in the clinical setting, *Fertil Steril* 80:577, 2003.
282. **Scheffer GJ, Broekmans FJ, Bancsi LF, Habbema JD, Looman CW, Te Velde ER**, Quantitative transvaginal two- and three-dimensional sonography of the ovaries: reproducibility of antral follicle counts, *Ultrasound Obstet Gynecol* 20:270, 2002.
283. **Broekmans FJ, Soules MR, Fauser BC**, Ovarian aging: mechanisms and clinical consequences, *Endocr Rev* 30:465, 2009.
284. **Hendriks DJ, Mol BW, Bancsi LF, Te Velde ER, Broekmans FJ**, Antral follicle count in the prediction of poor ovarian response and pregnancy after in vitro fertilization: a meta-analysis and comparison with basal follicle-stimulating hormone level, *Fertil Steril* 83:291, 2005.
285. **Hirshfield AN**, Rescue of atretic follicles in vitro and in vivo, *Biol Reprod* 40:181, 1989.
286. **Bancsi LF, Broekmans FJ, Eijkemans MJ, de Jong FH, Habbema JD, te Velde ER**, Predictors of poor ovarian response in in vitro fertilization: a prospective study comparing basal markers of ovarian reserve, *Fertil Steril* 77:328, 2002.
287. **Frattarelli JL, Lauria-Costab DF, Miller BT, Bergh PA, Scott RT**, Basal antral follicle number and mean ovarian diameter predict cycle cancellation and ovarian responsiveness in assisted reproductive technology cycles, *Fertil Steril* 74:512, 2000.
288. **Frattarelli JL, Levi AJ, Miller BT, Segars JH**, A prospective assessment of the predictive value of basal antral follicles in in vitro fertilization cycles, *Fertil Steril* 80:350, 2003.
289. **Chang MY, Chiang CH, Hsieh TT, Soong YK, Hsu KH**, Use of the antral follicle count to predict the outcome of assisted reproductive technologies, *Fertil Steril* 69:505, 1998.
290. **Ng EH, Tang OS, Ho PC**, The significance of the number of antral follicles prior to stimulation in predicting ovarian responses in an IVF programme, *Hum Reprod* 15:1937, 2000.
291. **Kupesic S, Kurjak A, Bjelos D, Vujisic S**, Three-dimensional ultrasonographic ovarian measurements and in vitro fertilization outcome are related to age, *Fertil Steril* 79:190, 2003.
292. **Lass A, Silye R, Abrams D-C, Krausz T, Hovatta O, Margara R, Winston RML**, Follicular density in ovarian biopsy of infertile women: a novel method to assess ovarian reserve, *Hum Reprod* 12:1028, 1997.
293. **Lass A, Skull J, McVeigh E, Margara R, Winston RM**, Measurement of ovarian volume by transvaginal sonography before human menopausal gonadotrophin superovulation for in-vitro fertilization can predict poor response, *Hum Reprod* 12:294, 1997.
294. **Jayaprakasan K, Campbell B, Hopkisson J, Clewes J, Johnson I, Raine-Fenning N**, Establishing the intercycle variability of three-dimensional ultrasonographic predictors of ovarian reserve, *Fertil Steril* 90:2126, 2008.
295. **Elter K, Sismanoglu A, Durmusoglu F**, Intercycle variabilities of basal antral follicle count and ovarian volume in subfertile women and their relationship to reproductive aging: a prospective study, *Gynecol Endocrinol* 20:137, 2005.
296. **Merce LT, Gomez B, Engels V, Bau S, Bajo JM**, Intraobserver and interobserver reproducibility of ovarian

volume, antral follicle count, and vascularity indices obtained with transvaginal 3-dimensional ultrasonography, power Doppler angiography, and the virtual organ computer-aided analysis imaging program, *J Ultrasound Med* 24:1279, 2005.

297. **Jarvela IY, Sladkevicius P, Kelly S, Ojha K, Campbell S, Nargund G**, Quantification of ovarian power Doppler signal with three-dimensional ultrasonography to predict response during in vitro fertilization, *Obstet Gynecol* 102:816, 2003.
298. **Schild RL, Knobloch C, Dorn C, Fimmers R, van der Ven H, Hansmann M**, The role of ovarian volume in an in vitro fertilization programme as assessed by 3D ultrasound, *Arch Gynecol Obstet* 265:67, 2001.
299. **Kwee J, Elting ME, Schats R, McDonnell J, Lambalk CB**, Ovarian volume and antral follicle count for the prediction of low and hyper responders with in vitro fertilization, *Reprod Biol Endocrinol* 5:9, 2007.
300. **Merce LT, Barco MJ, Bau S, Troyano JM**, Prediction of ovarian response and IVF/ICSI outcome by three-dimensional ultrasonography and power Doppler angiography, *Eur J Obstet Gynecol Reprod Biol* 132:93, 2007.
301. **Fanchin R, de Ziegler D, Olivennes F, Taieb J, Dzik A, Frydman R**, Exogenous follicle stimulating hormone ovarian reserve test (EFORT): a simple and reliable screening test for detecting 'poor responders' in in-vitro fertilization, *Hum Reprod* 9:1607, 1994.
302. **Seifer DB, Lambert-Messerlian G, Hogan JW, Gardiner AC, Blazar AS, Berk CA**, Day 3 serum inhibin-B is predictive of assisted reproductive technologies outcome, *Fertil Steril* 67:110, 1997.
303. **Corson SL, Gutmann J, Batzer FR, Wallace H, Klein N, Soules MR**, Inhibin-B as a test of ovarian reserve for infertile women, *Hum Reprod* 14:2818, 1999.
304. **Dzik A, Lambert-Messerlian G, Izzo VM, Soares JB, Pinotti JA, Seifer DB**, Inhibin B response to EFORT is associated with the outcome of oocyte retrieval in the subsequent in vitro fertilization cycle, *Fertil Steril* 74:1114, 2000.
305. **Kwee J, Elting MW, Schats R, Bezemer PD, Lambalk CB, Schoemaker J**, Comparison of endocrine tests with respect to their predictive value on the outcome of ovarian hyperstimulation in IVF treatment: results of a prospective randomized study, *Hum Reprod* 18:1422, 2003.
306. **Winslow KL, Toner JP, Brzyski RG, Oehninger SC, Acosta AA, Muasher SJ**, The gonadotropin-releasing hormone agonist stimulation test—a sensitive predictor of performance in the flare-up in vitro fertilization cycle, *Fertil Steril* 56:711, 1991.
307. **Galtier-Dereure F, De Bouard V, Picto MC, Vergnes C, Humeau C, Bringer J, Hedon B**, Ovarian reserve test with the gonadotrophin-releasing hormone agonist buserelin: correlation with in-vitro fertilization outcome, *Hum Reprod* 11:1393, 1996.
308. **Ranieri DM, Phophong P, Khadum I, Meo F, Davis C, Serhal P**, Simultaneous evaluation of basal FSH and oestradiol response to GnRH analogue (F-G-test) allows effective drug regimen selection for IVF, *Hum Reprod* 16:673, 2001.
309. **Verhagen TE, Hendriks DJ, Bancsi LF, Mol BW, Broekmans FJ**, The accuracy of multivariate models predicting ovarian reserve and pregnancy after in vitro fertilization: a meta-analysis, *Hum Reprod Update* 14:95, 2008.
310. **van Tilborg TC, Oudshoorn SC, Eijkemans MJC, Mochtar MH, van Golde RJT, Hoek A, Kuchenbecker WKH, Fleischer K, de Bruin JP, Groen H, van Wely M, Lambalk CB, Laven JSE, Mol BWJ, Broekmans FJM, Torrance HL; OPTIMIST study group**, Individualized FSH dosing based on ovarian reserve testing in women starting IVF/ICSI: a multicentre trial and cost-effectiveness analysis, *Hum Reprod* 32:2485, 2017.
311. **van Tilborg TC, Torrance HL, Oudshoorn SC, Eijkemans MJC, Koks CAM, Verhoeve HR, Nap AW, Scheffer GJ, Manger AP, Schoot BC, Sluijmer AV, Verhoeff A, Groen H, Laven JSE, Mol BWJ, Broekmans FJM; OPTIMIST study group**, Individualized versus standard FSH dosing in women starting IVF/ICSI: an RCT. Part 1: The predicted poor responder, *Hum Reprod* 32:2496, 2017.
312. **Oudshoorn SC, van Tilborg TC, Eijkemans MJC, Oosterhuis GJE, Friederich J, van Hooff MHA, van Santbrink EJP, Brinkhuis EA, Smeenk MJJ, Kwee J, de Koning CH, Groen H, Lambalk CB, Mol BWJ, Broekmans FJM, Torrance HL; OPTIMIST study group**, Individualized versus standard

FSH dosing in women starting IVF/ICSI: an RCT. Part 2: The predicted hyper responder, *Hum Reprod* 32:2506; 2017.

313. **Harrison RF, Jacob S, Spillane H, Mallon E, Hennelly B**, A prospective randomized clinical trial of differing starter doses of recombinant follicle-stimulating hormone (follitropin-beta) for first time in vitro fertilization and intracytoplasmic sperm injection treatment cycles, *Fertil Steril* 75:23, 2001.
314. **Klinkert ER, Broekmans FJ, Looman CW, Habbema JD, te Velde ER**, Expected poor responders on the basis of an antral follicle count do not benefit from a higher starting dose of gonadotrophins in IVF treatment: a randomized controlled trial, *Hum Reprod* 20:611, 2005.
315. **Popovic-Todorovic B, Loft A, Ziebe S, Andersen AN**, Impact of recombinant FSH dose adjustments on ovarian response in the second treatment cycle with IVF or ICSI in "standard" patients treated with 150 IU/day during the first cycle, *Acta Obstet Gynecol Scand* 83:842, 2004.
316. **Tarlatzis BC, Zepiridis L, Grimbizis G, Bontis J**, Clinical management of low ovarian response to stimulation for IVF: a systematic review, *Hum Reprod Update* 9:61, 2003.
317. **Kyrou D, Kolibianakis EM, Venetis CA, Papanikolaou EG, Bontis J, Tarlatzis BC**, How to improve the probability of pregnancy in poor responders undergoing in vitro fertilization: a systematic review and meta-analysis, *Fertil Steril* 91:749, 2009.
318. **Barrenetxea G, Agirreagoikoa JA, Jimenez MR, de Larruzea AL, Ganzabal T, Carbonero K**, Ovarian response and pregnancy outcome in poor-responder women: a randomized controlled trial on the effect of luteinizing hormone supplementation on in vitro fertilization cycles, *Fertil Steril* 89:546, 2008.
319. **Scott RT Jr, Elkind-Hirsch KE, Styne-Gross A, Miller KA, Frattarelli JL**, The predictive value for in vitro fertility delivery rates is greatly impacted by the method used to select the threshold between normal and elevated basal follicle-stimulating hormone, *Fertil Steril* 89:868, 2008.
320. **van Rooij IA, de Jong E, Broekmans FJ, Looman CW, Habbema JD, te Velde ER**, High follicle-stimulating hormone levels should not necessarily lead to the exclusion of subfertile patients from treatment, *Fertil Steril* 81:1478, 2004.
321. **Lashen H, Ledger W, Lopez-Bernal A, Barlow D**, Poor responders to ovulation induction: is proceeding to in-vitro fertilization worthwhile? *Hum Reprod* 14:964, 1999.
322. **Zhen XM, Qiao J, Li R, Wang LN, Liu P**, The clinical analysis of poor ovarian response in in-vitro-fertilization embryo-transfer among Chinese couples, *J Assist Reprod Genet* 25:17, 2008.
323. **Scott RT Jr, Leonardi MR, Hofmann GE, Illions EH, Neal GS, Navot D**, A prospective evaluation of clomiphene citrate challenge test screening of the general infertility population, *Obstet Gynecol* 82:539, 1993.
324. **Scott RT, Opsahl MS, Leonardi MR, Neall GS, Illions EH, Navot D**, Life table analysis of pregnancy rates in a general infertility population relative to ovarian reserve and patient age, *Hum Reprod* 10:1706, 1995.
325. **Leach RE, Moghissi KS, Randolph JF, Reame NE, Blacker CM, Ginsburg KA, Diamond MP**, Intensive hormone monitoring in women with unexplained infertility: evidence for subtle abnormalities suggestive of diminished ovarian reserve, *Fertil Steril* 68:413, 1997.
326. **Hofmann GE, Sosnowski J, Scott RT, Thie J**, Efficacy of selection criteria for ovarian reserve screening using the clomiphene citrate challenge test in a tertiary fertility center population, *Fertil Steril* 66:49, 1996.
327. Prevalence of obesity among adults and youth: United States, 2015-2016. <https://www.cdc.gov/nchs/data/databriefs/db288.pdf>
328. **Practice Committee of the American Society for Reproductive Medicine**, Obesity and reproduction, *Fertil Steril* 90(Suppl 5):S21, 2008.
329. **Practice Committee of the American Society for Reproductive Medicine**, Smoking and infertility, *Fertil Steril* 90(Suppl 5):S254, 2008.
330. **Stillman RJ, Rosenberg MJ, Sachs BP**, Smoking and reproduction, *Fertil Steril* 46:545, 1986.
331. **Laurent SL, Thompson SJ, Addy C, Garrison CZ, Moore EE**, An epidemiologic study of smoking and primary infertility in women, *Fertil Steril* 57:565, 1992.
332. **Hughes EG, Brennan BG**, Does cigarette smoking impair natural or assisted fecundity, *Fertil Steril* 66:679, 1996.
333. **Augood C, Duckitt K, Templeton AA**, Smoking and female infertility: a systematic review and meta-



- analysis, *Hum Reprod* 13:1532, 1998.
334. **Hakim RB, Gray RH, Zacur H**, Alcohol and caffeine consumption and decreased fertility, *Fertil Steril* 70:632, 1998.
  335. **Hull MG, North K, Taylor H, Farrow A, Ford WC**, Delayed conception and active and passive smoking. The Avon Longitudinal Study of Pregnancy and Childhood Study Team, *Fertil Steril* 74:725, 2000.
  336. **Baird DD, Wilcox AJ**, Cigarette smoking associated with delayed conception, *JAMA* 253:2979, 1985.
  337. **Suonio S, Saarikoski S, Kauhanen O, Metsapelto A, Terho J, Vohlonen I**, Smoking does affect fecundity, *Eur J Obstet Gynecol Reprod Biol* 34:89, 1990.
  338. **Howe G, Westhoff C, Vessey M, Yeates D**, Effects of age, cigarette smoking, and other factors on fertility: findings in a large prospective study, *Br Med J (Clin Res Ed)* 290:1697, 1985.
  339. **Cooper GS, Baird DD, Hulka BS, Weinberg CR, Savitz DA, Hughes CL Jr**, Follicle-stimulating hormone concentrations in relation to active and passive smoking, *Obstet Gynecol* 85:407, 1995.
  340. **El-Nemr A, Al-Shawaf T, Sabatini L, Wilson C, Lower AM, Grudzinskas JG**, Effect of smoking on ovarian reserve and ovarian stimulation in in-vitro fertilization and embryo transfer, *Hum Reprod* 13:2192, 1998.
  341. **Sharara FI, Beatse SN, Leonardi MR, Navot D, Scott RT Jr**, Cigarette smoking accelerates the development of diminished ovarian reserve as evidenced by the clomiphene citrate challenge test, *Fertil Steril* 62:257, 1994.
  342. **Rowland AS, Baird DD, Long S, Wegienka G, Harlow SD, Alavanja M, Sandler DP**, Influence of medical conditions and lifestyle factors on the menstrual cycle, *Epidemiology* 13:668, 2002.
  343. **Zenzes MT, Wang P, Casper RF**, Cigarette smoking may affect meiotic maturation of human oocytes, *Hum Reprod* 10:3213, 1995.
  344. **Zenzes MT, Reed TE, Wang P, Klein J**, Cotinine, a major metabolite of nicotine, is detectable in follicular fluids of passive smokers in in vitro fertilization therapy, *Fertil Steril* 66:614, 1996.
  345. **Zenzes MT, Krishnan S, Krishnan B, Zhang H, Casper RF**, Cadmium accumulation in follicular fluid of women in in vitro fertilization-embryo transfer is higher in smokers, *Fertil Steril* 64:599, 1995.
  346. **Zenzes MT, Bielecki R, Reed TE**, Detection of benzo(a)pyrene diol epoxide-DNA adducts in sperm of men exposed to cigarette smoke, *Fertil Steril* 72:330, 1999.
  347. **Zenzes MT, Puy LA, Bielecki R, Reed TE**, Detection of benzo[a]pyrene diol epoxide-DNA adducts in embryos from smoking couples: evidence for transmission by spermatozoa, *Mol Hum Reprod* 5:125, 1999.
  348. **Center for Disease Control (CDC)**, Preconception and interconception health status of women who recently gave birth to a live-born infant—Pregnancy Risk Assessment Monitoring System (PRAMS)—United States, 26 reporting areas, 2004, *MMWR Morb Mortal Wkly Rep* 56(10):1, 2007.
  349. **Center for Disease Control (CDC)**, State-specific prevalence of cigarette smoking among adults and quitting among persons aged 18–35 years—United States, 2006, *MMWR Morb Mortal Wkly Rep* 56(38):993, 2007.
  350. **Fiore MC**, US public health service clinical practice guideline: treating tobacco use and dependence, *Respir Care* 45:1200, 2000.
  351. **Smith CG, Asch RH**, Drug abuse and reproduction, *Fertil Steril* 48:355, 1987.
  352. **Mueller BA, Daling JR, Weiss NS, Moore DE**, Recreational drug use and the risk of primary infertility, *Epidemiology* 1:195, 1990.
  353. **Bracken MB, Eskenazi B, Sachse K, McSharry J-E, Hellenbrand K, Leon-Summers L**, Association of cocaine use with sperm concentration, motility, and morphology, *Fertil Steril* 53:315, 1990.
  354. **Grodstein F, Goldman MB, Cramer DW**, Infertility in women and moderate alcohol use, *Am J Public Health* 84:1429, 1994.
  355. **Tolstrup JS, Kjaer SK, Holst C, Sharif H, Munk C, Osler M, Schmidt L, Andersen AM, Gronbaek M**, Alcohol use as predictor for infertility in a representative population of Danish women, *Acta Obstet Gynecol Scand* 82:744, 2003.
  356. **Greenlee AR, Arbuckle TE, Chyou PH**, Risk factors for female infertility in an agricultural region, *Epidemiology* 14:429, 2003.
  357. **Nagy F, Pendergrass PB, Bowen DC, Yeager JC**, A comparative study of cytological and physiological

parameters of semen obtained from alcoholics and non-alcoholics, *Alcohol* 21:17, 1986.

358. **Jensen TK, Hjollund NH, Henriksen TB, Scheike T, Kolstad H, Giwercman A, Ernst E, Bonde JP, Skakkebaek NE, Olsen J**, Does moderate alcohol consumption affect fertility? Follow up study among couples planning first pregnancy, *Br Med J* 317:505, 1998.
359. **Juhl M, Nyboe Andersen AM, Gronbaek M, Olsen J**, Moderate alcohol consumption and waiting time to pregnancy, *Hum Reprod* 16:2705, 2001.
360. **Klonoff-Cohen H, Lam-Kruglick P, Gonzalez C**, Effects of maternal and paternal alcohol consumption on the success rates of in vitro fertilization and gamete intrafallopian transfer, *Fertil Steril* 79:330, 2003.
361. **Bolumar F, Olsen J, Rebagliato M, Bisanti L**, Caffeine intake and delayed conception: a European multicenter study on infertility and subfecundity. European Study Group on Infertility and Subfecundity, *Am J Epidemiol* 145:324, 1997.
362. **Caan B, Quesenberry CP Jr, Coates AO**, Differences in fertility associated with caffeinated beverage consumption, *Am J Public Health* 88:270, 1998.
363. **Cnattingius S, Signorello LB, Anneren G, Clausson B, Ekblom A, Ljunger E, Blot WJ, McLaughlin JK, Petersson G, Rane A, Granath F**, Caffeine intake and the risk of first-trimester spontaneous abortion, *N Engl J Med* 343:1839, 2000.
364. **American College of Obstetrics and Gynecology**, Frequently asked questions FAQ001 pregnancy, 2018.
365. **Hruska KS, Furth PA, Seifer DB, Sharara FI, Flaws JA**, Environmental factors in infertility, *Clin Obstet Gynecol* 43:821, 2000.
366. **Stevens VC**, Some reproductive studies in the baboon, *Hum Reprod Update* 3:533, 1997.
367. **Wilcox AJ, Weinberg CR, Baird DD**, Timing of sexual intercourse in relation to ovulation—effects on the probability of conception, survival of the pregnancy, and sex of the baby, *N Engl J Med* 333:1517, 1995.
368. **Guttmacher AF**, Factors affecting normal expectancy of conception, *JAMA* 161:855, 1956.
369. **Evers JL**, Female subfertility, *Lancet* 360:151, 2002.
370. **Wilcox AJ, Weinberg CR, Baird DD**, Post-ovulatory ageing of the human oocyte and embryo failure, *Hum Reprod* 13:394, 1998.
371. **Dunson DB, Baird DD, Wilcox AJ, Weinberg CR**, Day-specific probabilities of clinical pregnancy based on two studies with imperfect measures of ovulation, *Hum Reprod* 14:1835, 1999.
372. **Miller PB, Soules MR**, The usefulness of a urinary LH kit for ovulation prediction during menstrual cycles of normal women, *Obstet Gynecol* 87: 13, 1996.
373. **Nielsen MS, Barton SD, Hatasaka HH, Stanford JB**, Comparison of several one-step home urinary luteinizing hormone detection test kits to OvuQuick, *Fertil Steril* 76:384, 2001.
374. **Manders M, McLindon L, Schulze B, Beckmann MM, Kremer JA, Farquhar C**, Timed intercourse for couples trying to conceive, *Cochrane Database Syst Rev*, (3):CD011345, 2015. doi: 10.1002/14651858.CD011345.pub2.
375. **Agarwal SK, Haney AF**, Does recommending timed intercourse really help the infertile couple? *Obstet Gynecol* 84:307, 1994.
376. **Miller JH, Weinberg RK, Canino NL, Klein NA, Soules MR**, The pattern of infertility diagnoses in women of advanced reproductive age, *Am J Obstet Gynecol* 181:952, 1999.
377. **Maheshwari A, Hamilton M, Bhattacharya S**, Effect of female age on the diagnostic categories of infertility, *Hum Reprod* 23:538, 2008.
378. **Snick HK, Snick TS, Evers JL, Collins JA**, The spontaneous pregnancy prognosis in untreated subfertile couples: the Walcheren primary care study, *Hum Reprod* 12:1582, 1997.
379. **Hull MG, Glazener CM, Kelly NJ, Conway DI, Foster PA, Hinton RA, Coulson C, Lambert PA, Watt EM, Desai KM**, Population study of causes, treatment, and outcome of infertility, *Br Med J (Clin Res Ed)* 291:1693, 1985.
380. **Collins JA, Burrows EA, Wilan AR**, The prognosis for live birth among untreated infertile couples, *Fertil Steril* 64:22, 1995.
381. **Sundstrom I, Ildgruben A, Hogberg U**, Treatment-related and treatment-independent deliveries among infertile couples, a long-term follow-up, *Acta Obstet Gynecol Scand* 76:238, 1997.

382. **Eimers JM, te Velde ER, Gerritse R, Vogelzang ET, Looman CW, Habbe ma JD**, The prediction of the chance to conceive in subfertile couples, *Fertil Steril* 61:44, 1994.
383. **Bostofte E, Bagger P, Michael A, Stake mann G**, Fertility prognosis for infertile couples, *Fertil Steril* 59:102, 1993.
384. **Practice Committee of the American Society for Reproductive Medicine**, Diagnostic evaluation of the infertile female: a committee opinion, *Fertil Steril* 103(6):e44, 2015.
385. **Stubblefield P, Monson R, Schoenbaum S, Wolfson CE, Cookson DJ, Ryan KJ**, Fertility after induced abortion: a prospective follow-up study, *Obstet Gynecol* 62:186, 1984.
386. **Frank P, McNamee R, Hannaford PC, Kay CR, Hirsch S**, The effect of induced abortion on subsequent fertility, *Br J Obstet Gynaecol* 100:575, 1993.
387. **U.S. Preventive Services Task Force**, Cervical Cancer: Screening, <https://www.uspreventiveservicestaskforce.org/Page/Document/UpdateSummaryFinal/cervical-cancer-screening>
388. **American College of Obstetricians and Gynecologists**, ACOG Committee Opinion. Number 690, March 2017. Carrier screening in the age of genomic medicine, *Obstet Gynecol* 129(3):e35, 2017.
389. **Practice Committee of American Society for Reproductive Medicine**, Vaccination guidelines for female infertility patients: a committee opinion, *Fertil Steril* 99(2):337, 2013.
390. **Soares RC, Siqueira MM, Toscano CM, Maia Mde L, Flannery B**, et al., Follow-up study of unknowingly pregnant women vaccinated against rubella in Brazil, 2001-2002, *J Infect Dis* 204:S729, 2011.
391. **Workowski KA, Bolan GA**, Sexually transmitted diseases treatment guidelines, 2015, *MMWR Recomm Rep* 64:3, 2015.
392. **Practice Committee of the American Society for Reproductive Medicine and Practice Committee of the Society for Assisted Reproductive Technology**, Recommendations for gamete and embryo donation: a committee opinion, *Fertil Steril* 99(1):47, 2013.
393. **Practice Committee of the American Society for Reproductive Medicine**, Diagnostic evaluation of the infertile male, *Fertil Steril* 103(3):e18, 2015.
394. **Bates GW, Garza DE, Garza MM**, Clinical manifestations of hormonal changes in the menstrual cycle, *Obstet Gynecol Clin North Am* 17:299, 1990.
395. **Quagliarello J, Arny M**, Inaccuracy of basal body temperature charts in predicting urinary luteinizing hormone surges, *Fertil Steril* 45:334, 1986.
396. **Luciano AA, Peluso J, Koch E, Maier D, Kuslis S, Davison E**, Temporal relationship and reliability of the clinical, hormonal, and ultrasonographic indices of ovulation in infertile women, *Obstet Gynecol* 75:412, 1990.
397. **Abraham GE, Maroulis GB, Marshall JR**, Evaluation of ovulation and corpus luteum function using measurements of plasma progesterone, *Obstet Gynecol* 44:522, 1974.
398. **Wathen NC, Perry L, Lilford RJ, Chard T**, Interpretation of single progesterone measurement in diagnosis of anovulation and defective luteal phase: observations on analysis of the normal range, *Br Med J* 288:7, 1984.
399. **Soules MR, McLachlan RI, Ek M, Dahl KD, Cohen NL, Bremner WJ**, Luteal phase deficiency: characterization of reproductive hormones over the menstrual cycle, *J Clin Endocrinol Metab* 69:804, 1989.
400. **Soules MR, Clifton DK, Cohen NL, Bremner WJ, Steiner RA**, Luteal phase deficiency: abnormal gonadotropin and progesterone secretion patterns, *J Clin Endocrinol Metab* 69:813, 1989.
401. **Li TC, Lenton EA, Dockery P, Cooke ID**, A comparison of some clinical and endocrinological features between cycles with normal and defective luteal phases in women with unexplained infertility, *Hum Reprod* 5:805, 1990.
402. **Cooke ID, Morgan CA, Parry TE**, Correlation of endometrial biopsy and plasma progesterone levels in infertile women, *J Obstet Gynaecol Br Commonw* 79:647, 1972.
403. **Shepard MK, Senturia YD**, Comparison of serum progesterone and endometrial biopsy for confirmation of ovulation and evaluation of luteal function, *Fertil Steril* 28:541, 1977.
404. **Rosenfeld DL, Chudow S, Bronson RA**, Diagnosis of luteal phase inadequacy, *Obstet Gynecol* 56:193, 1980.
405. **Cumming DC, Honore LH, Scott JZ, Williams KP**, The late luteal phase in infertile women: comparison of

simultaneous endometrial biopsy and progesterone levels, *Fertil Steril* 43:715, 1985.

406. **Li T-C, Lenton EA, Dockery P, Rogers AW, Cooke ID**, The relation between daily salivary progesterone profile and endometrial development in the luteal phase of fertile and infertile women, *Br J Obstet Gynaecol* 96:445, 1989.
407. **Jordan J, Craig K, Clifton DK, Soules MJ**, Luteal phase defect: the sensitivity and specificity of diagnostic methods in common use, *Fertil Steril* 62: 54, 1994.
408. **Hull MG, Savage PE, Bromham DR, Ismail AA, Morris AF**, The value of a single serum progesterone measurement in the midluteal phase as a criterion of a potentially fertile cycle (“ovulation”) derived from treated and untreated conception cycles, *Fertil Steril* 37:355, 1982.
409. **Ellinwood WE, Norman RL, Spies HG**, Changing frequency of pulsatile luteinizing hormone and progesterone secretion during the luteal phase of the menstrual cycle of rhesus monkeys, *Biol Reprod* 31:714, 1984.
410. **Filicori M, Butler JP, Crowley WF**, Neuroendocrine regulation of the corpus luteum in the human: evidence for pulsatile progesterone secretion, *J Clin Invest* 73:1638, 1984.
411. **McGovern PG, Myers ER, Silva S, Coutifaris C, Carson SA, Legro RS, Schlaff WD, Carr BR, Steinkampf MP, Giudice LC, Leppert PC, Diamond MP**, Absence of secretory endometrium after false-positive home urine luteinizing hormone testing, *Fertil Steril* 82:1273, 2004.
412. **Martinez AR, Bernardus RE, Vermeiden JP, Schoemaker J**, Reliability of home urinary LH tests for timing of insemination: a consumer’s study, *Hum Reprod* 7:751, 1992.
413. **Johnson S, Ellis J, Godbert S, Ali S, Zinaman M**, Comparison of a digital ovulation test with three popular line ovulation tests to investigate user accuracy and certainty, *Expert Opin Med Diagn* 5(6):467, 2011.
414. **Martinez AR, Bernardus RE, Vermeiden JP, Schoemaker J**, Time schedules of intrauterine insemination after urinary luteinizing hormone surge detection and pregnancy results, *Gynecol Endocrinol* 8:1, 1994.
415. **Meyer WR, Smith PM, Clark MR, Cusmano LL, Fritz MA**, Therapeutic cup insemination with cryopreserved donor sperm: prognostic value of cervical mucus score at insemination and the number of motile sperm in mucus at 24 hours, *Fertil Steril* 66:435, 1996.
416. **Tiplady S, Jones G, Campbell M, Johnson S, Ledger W**, Home ovulation tests and stress in women trying to conceive: a randomized controlled trial, *Hum Reprod* 28(1):138, 2013. doi:10.1093/humrep/des372. Epub 2012 Oct 18.
417. **Jones G, Carlton J, Weddell S, Johnson S, Ledger WL**, Women’s experiences of ovulation testing: a qualitative analysis, *Reprod Health* 12:116, 2015.
418. **Jones GS**, Some newer aspects of the management of infertility, *JAMA* 141:1123, 1949.
419. **Jones GS**, The luteal phase defect, *Fertil Steril* 27:351, 1976.
420. **Hertig AT, Rock J, Adams EC**, A description of 34 human ova within the first 17 days of development, *Am J Anat* 98:435, 1956.
421. **Navot RW, Scott RT, Doresch K, Veeck LL, Liu HC, Rosenwaks Z**, The window of embryo transfer and the efficiency of human conception in vitro, *Fertil Steril* 55:114, 1991.
422. **Bergh PA, Navot D**, The impact of embryonic development and endometrial maturity on the timing of implantation, *Fertil Steril* 58:537, 1992.
423. **Fritz MA, Hess DL, Patton PE**, Influence of corpus luteum age on the steroidogenic response to exogenous human chorionic gonadotropin in normal cycling women, *Am J Obstet Gynecol* 167:709, 1992.
424. **Lessey BA, Fritz MA**, Defective luteal function, In: Fraser IS, et al., eds. *Estrogen and Progestogens in Clinical Practice*, Churchill Livingstone, London, 1998.
425. **Tay PY, Lenton EA**, The optimum time for exogenous human chorionic gonadotropin to rescue the corpus luteum, *J Assist Reprod Genet* 16:495, 1999.
426. **Wilcox AJ, Baird DD, Weinberg CR**, Time of implantation of the conceptus and loss of pregnancy, *N Engl J Med* 340:1796, 1999.
427. **Noyes RW, Hertig AW, Rock J**, Dating the endometrial biopsy, *Fertil Steril* 1:3, 1950.
428. **Shoupe D, Mishell DR Jr, Lacarra M, Lobo R, Horenstein J, d’Ablaing G, Moyer D**, Correlation of endometrial maturation with four methods of estimating day of ovulation, *Obstet Gynecol* 73:88, 1989.

429. **Noyes RW, Haman JO**, Accuracy of endometrial dating: correlation of endometrial dating with basal body temperature and menses, *Fertil Steril* 4:504, 1953.
430. **Andrews WC**, Luteal phase defects, *Fertil Steril* 32:501, 1979.
431. **Duggan MA, Brashert P, Ostor A, Scurry J, Billson V, Kneafsey P, Difrancesco L**, The accuracy and interobserver reproducibility of endometrial dating, *Pathology* 33:292, 2001.
432. **Aksel S**, Sporadic and recurrent luteal phase defects in cyclic women: comparison with normal cycles, *Fertil Steril* 33:372, 1980.
433. **Wentz AC, Kossoy L, Parker RA**, The impact of luteal phase inadequacy in an infertile population, *Am J Obstet Gynecol* 162:937, 1990.
434. **Li TC, Dockery P, Cooke ID**, Endometrial development in the luteal phase of women with various types of infertility: comparison with women of normal fertility, *Hum Reprod* 6:325, 1991.
435. **Balasz J, Fabreques F, Creus M, Vanrell JA**, The usefulness of endometrial biopsy for luteal phase evaluation in infertility, *Hum Reprod* 7:973, 1992.
436. **Peters AJ, Lloyd RP, Coulam CP**, Prevalence of out-of-phase endometrial biopsy specimens, *Am J Obstet Gynecol* 166:1738, 1992.
437. **Batista MC, Cartledge TP, Merino MJ, Axiotis C, Platia MP, Merriam GR, Loriaux DL, Nieman LK**, Midluteal phase endometrial biopsy does not accurately predict luteal function, *Fertil Steril* 59:294, 1993.
438. **Davis OK, Berkeley AS, Naus GJ, Cholst IN, Freedman KS**, The incidence of luteal phase defect in normal, fertile women, determined by serial endometrial biopsies, *Fertil Steril* 51:582, 1989.
439. **Johannisson E, Parker RA, Landgren BM, Diczfalusy E**, Morphometric analysis of the human endometrium in relation to peripheral hormone levels, *Fertil Steril* 38:564, 1982.
440. **Munster K, Schmidt L, Helm P**, Length and variation in the menstrual cycle—a cross-sectional study from a Danish county, *Br J Obstet Gynaecol* 99: 422, 1992.
441. **Guermandi E, Vegetti W, Bianchi MM, Uglietti A, Ragni G, Crosignani P**, Reliability of ovulation tests in infertile women, *Obstet Gynecol* 97:92, 2001.
442. **Lenton EA, Landgren B, Sexton L, Harper R**, Normal variation in the length of the follicular phase of the menstrual cycle: effect of chronological age, *Br J Obstet Gynaecol* 91:681, 1984.
443. **Scott RT, Snyder RR, Strickland DM, Tyburski CC, Bagnall JA, Reed KR, Adair CA, Hensley SB**, The effect of interobserver variation in dating endometrial histology on the diagnosis of luteal phase defects, *Fertil Steril* 50: 888, 1988.
444. **Gibson M, Badger GJ, Byrn F, Lee KR, Korson R, Trainer TD**, Error in histologic dating of secretory endometrium: variance component analysis, *Fertil Steril* 56:242, 1991.
445. **Scott RT, Snyder RR, Bagnall JW, Reed KD, Adair CF, Hensley SD**, Evaluation of the impact of intraobserver variability on endometrial dating and the diagnosis of luteal phase defects, *Fertil Steril* 60:652, 1993.
446. **Smith S, Hosid S, Scott L**, Endometrial biopsy dating. Interobserver variation and its impact on clinical practice, *J Reprod Med* 40:1, 1995.
447. **Murray MJ, Meyer WR, Zaino RJ, Lessey BA, Novotny DB, Ireland I, Fritz MA**, A critical reanalysis of the accuracy, reproducibility, and clinical utility of histologic endometrial dating: a systematic study of the secretory phase in normally cycling, fertile women, *Fertil Steril* 81:1333, 2004.
448. **Coutifaris C, Myers ER, Guzick DS, Diamond MP, Carson SA, Legro RS, McGovern PG, Schlaff WD, Carr BR, Steinkampf MP, Silva S, Vogel DL, Leppert PC**, Histological dating of timed endometrial biopsy tissue is not related to fertility status, *Fertil Steril* 82:1264, 2004.
449. **Usadi RS, Groll JM, Lessey BA, Lininger RA, Zaino RJ, Fritz MA, Young SL**, Endometrial development and function in experimentally induced luteal phase deficiency, *J Clin Endocrinol Metab* 93:4058, 2008.
450. **Groll JM, Usadi RS, Lessey BA, Lininger R, Young SL, Fritz MA**, Effects of variations in serum estradiol concentrations on secretory endometrial development and function in experimentally induced cycles in normal women, *Fertil Steril* 92:2058, 2009.
451. **Young SL, Lessey BA**, Progesterone function in human endometrium: clinical perspectives, *Semin Reprod*

Med 28:5, 2010.

452. **Talbi S, Hamilton AE, Vo KC, Tulac S, Overgaard MT, Dosiou C, Le Shay N, Nezhat CN, Kempson R, Lessey BA, Nayak NR, Giudice LC**, Molecular phenotyping of human endometrium distinguishes menstrual cycle phases and underlying biological processes in normo-ovulatory women, *Endocrinology* 147:1097, 2006.
453. **Eun Kwon H, Taylor HS**, The role of HOX genes in human implantation [Review], *Ann N Y Acad Sci* 1034:1, 2004.
454. **Taylor HS, Arici A, Olive D, Igarashi P**, HOXA10 is expressed in response to sex steroids at the time of implantation in the human endometrium, *J Clin Invest* 101(7):1379, 1998.
455. **Taylor HS**, The role of HOX genes in human implantation, *Hum Reprod Update* 6(1):75, 2000.
456. **Taylor HS, Igarashi P, Olive DL, Arici A**, Sex steroids mediate HOXA11 expression in the human peri-implantation endometrium, *J Clin Endocrinol Metab* 84(3):1129, 1999.
457. **Lessey BA**, Endometrial integrins and the establishment of uterine receptivity, *Hum Reprod* 13(Suppl 3):247, 1998.
458. **Lindhard A, Bentin-Ley U, Ravn V, Islin H, Hviid T, Rex S, Bangsboll S, Sorensen S**, Biochemical evaluation of endometrial function at the time of implantation, *Fertil Steril* 78:221, 2002.
459. **Apparao KB, Murray MJ, Fritz MA, Meyer WR, Chambers AF, Truong PR, Lessey BA**, Osteopontin and its receptor  $\alpha$ 5 $\beta$ 1 integrin are coexpressed in the human endometrium during the menstrual cycle but regulated differentially, *J Clin Endocrinol Metab* 86:4991, 2001.
460. **Carson DD, Lagow E, Thathiah A, Al-Shami R, Farach-Carson MC, Vernon M, Yuan L, Fritz MA, Lessey B**, Changes in gene expression during the early to mid-luteal (receptive phase) transition in human endometrium detected by high-density microarray screening, *Mol Hum Reprod* 8:871, 2002.
461. **Allan G, Campen C, Hodgen G, Williams R, Charnock-Jones DS, Wan J, Erlander M, Palmer S**, Identification of genes with differential regulation in primate endometrium during the proliferative and secretory phases of the cycle, *Endocr Res* 29:53, 2003.
462. **Kao LC, Germeyer A, Tulac S, Lobo S, Yang JP, Taylor RN, Osteen K, Lessey BA, Giudice LC**, Expression profiling of endometrium from women with endometriosis reveals candidate genes for disease-based implantation failure and infertility, *Endocrinology* 144:2870, 2003.
463. **Genbacev OD, Prakobphol A, Foulk RA, Krtolica AR, Ilic D, Singer MS, Yang ZQ, Kiessling LL, Rosen SD, Fisher SJ**, Trophoblast L-selectin-mediated adhesion at the maternal-fetal interface, *Science* 299:405, 2003.
464. **Díaz-Gimeno P, Horcajadas JA, Martínez-Conejero JA, Esteban FJ, Alamá P, Pellicer A, Simon C**, A genomic diagnostic tool for human endometrial receptivity based on the transcriptomic signature, *Fertil Steril* 95:50, 2011.
465. **Ruiz-Alonso M, Blesa D, Díaz-Gimeno P, Gomez E, Fernandez-Sanchez M, Carranza F, Carrera J, Vilella F, Pellicer A, Simon C**, The endometrial receptivity array for diagnosis and personalized embryo transfer as a treatment for patients with repeated implantation failure, *Fertil Steril* 100:818, 2013.
466. **Koot YE, van Hooff SR, Boomsma CM, van Leenen D, Groot Koerkamp MJ, Goddijn M, Eijkemans MJ, Fauser BC, Holstege FC, Macklon NS**, An endometrial gene expression signature accurately predicts recurrent implantation failure after IVF, *Sci Rep* 6:19411, 2016. doi: 10.1038/srep19411.
467. **de Crespigny LC, O'Herlihy C, Robinson HP**, Ultrasonic observation of the mechanism of human ovulation, *Am J Obstet Gynecol* 139:636, 1981.
468. **Ecochard R, Marret H, Rabilloud M, Bradai R, Boehringer H, Girotto S, Barbato M**, Sensitivity and specificity of ultrasound indices of ovulation in spontaneous cycles, *Eur J Obstet Gynecol Reprod Biol* 91:59, 2000.
469. **Petsos P, Chandler C, Oak M, Ratcliffe WA, Wood R, Anderson DC**, The assessment of ovulation by a combination of ultrasound and detailed serial hormone profiles in 35 women with long-standing unexplained infertility, *Clin Endocrinol (Oxf)* 22:739, 1985.
470. **Daly DC, Soto-Albors C, Walters C, Ying YK, Riddick DH**, Ultrasonographic assessment of luteinized unruptured follicle syndrome in unexplained infertility, *Fertil Steril* 43:62, 1985.

471. **Priddy AR, Killick SR, Elstein M, Morris J, Sullivan M, Patel L, Elder M**, The effect of prostaglandin synthetase inhibitors on human preovulatory follicular fluid prostaglandin, thromboxane, and leukotriene concentrations, *J Clin Endocrinol Metab* 71:235, 1990.
472. **Smith G, Roberts R, Hall C, Nuki G**, Reversible ovulatory failure associated with the development of luteinized unruptured follicles in women with inflammatory arthritis, *Br J Rheumatol* 35:458, 1996.
473. **Eggert-Kruse W, Reimann-Andersen J, Rohr G, Pohl S, Tilgen W, Runnebaum B**, Clinical relevance of sperm morphology assessment using strict criteria and relationship with sperm-mucus interaction in vivo and in vitro, *Fertil Steril* 63:612, 1995.
474. **Bonilla-Musoles F**, Scanner electron microscopy of the cervical mucus, *Clin Exp Obstet Gynecol* 10:151, 1983.
475. **Overstreet JW, Katz DF, Yudin AI**, Cervical mucus and sperm transport in reproduction, *Semin Perinatol* 15:149, 1991.
476. **Yudin AI, Hanson FW, Katz DF**, Human cervical mucus and its interaction with sperm: fine structural view, *Biol Reprod* 40:661, 1989.
477. **Katz DF**, Human cervical mucus: research update, *Am J Obstet Gynecol* 165:1984, 1991.
478. **Chretien FC**, Involvement of the glycoproteic meshwork of cervical mucus in the mechanism of sperm orientation, *Acta Obstet Gynecol Scand* 82:449, 2003.
479. **Katz DF, Slade DA, Nakajima ST**, Analysis of pre-ovulatory changes in cervical mucus hydration and sperm penetrability, *Adv Contracept* 13:143, 1997.
480. **Oei SG, Keirse MJ, Bloemenkamp KW, Helmerhorst FM**, European postcoital tests: opinions and practice, *Br J Obstet Gynaecol* 102:621, 1995.
481. **Franken DR, Pretorius E, Grobler S, De Wet JI**, Important semen parameters during postcoital testing, *Arch Androl* 14:213, 1985.
482. **Hull MG, Savage PE, Bromham DR**, Prognostic value of the postcoital test: prospective study based on time-specific conception rates, *Br J Obstet Gynaecol* 89:299, 1982.
483. **Quagliarello J, Army M**, Intracervical versus intrauterine insemination: correlation of outcome with antecedent postcoital testing, *Fertil Steril* 46:870, 1986.
484. **Glazener CM, Coulson C, Lambert PA, Watt EM, Hinton RA, Kelly NJ, Hull MG**, The value of artificial insemination with husband's semen in infertility due to failure of postcoital sperm-mucus penetration—controlled trial of treatment, *Br J Obstet Gynaecol* 94:774, 1987.
485. **Eimers JM, te Velde ER, Gerritse R, van Kooy RJ, Kremer J, Habbema JD**, The validity of the postcoital test for estimating the probability of conceiving, *Am J Obstet Gynecol* 171:65, 1994.
486. **Glazener CM, Ford WC, Hull MG**, The prognostic power of the post-coital test for natural conception depends on duration of infertility, *Hum Reprod* 15:1953, 2000.
487. **Collins JA, So Y, Wilson EH, Wrixon W, Casper RF**, The postcoital test as a predictor of pregnancy among 355 infertile couples, *Fertil Steril* 41:703, 1984.
488. **Oei SG, Helmerhorst FM, Keirse MJ**, When is the post-coital test normal? A critical appraisal, *Hum Reprod* 10:1711, 1995.
489. **Fehring RJ**, Accuracy of the peak day of cervical mucus as a biological marker of fertility, *Contraception* 66:231, 2002.
490. **Hamilton CJ, Evers JL, de Haan J**, Ultrasound increases the prognostic value of the postcoital test, *Gynecol Obstet Invest* 21:80, 1986.
491. **Kovacs GT, Newman GB, Henson GL**, The postcoital test: What is normal? *Br Med J* 1:818, 1978.
492. **Cimino C, Borruso AR, Napoli P, Cittadini E**, Evaluation of the importance of Chlamydia T. and/or Mycoplasma H. and/or Ureaplasma U. genital infections and of antisperm antibodies in couples affected by muco-semen incompatibility and in couples with unexplained infertility *Acta Eur Fertil* 24:13, 1993.
493. **Critchlow CW, Wölner-Hanssen P, Eschenbach DA, Kiviat NB, Koutsky LA, Stevens CE, Holmes KK**, Determinants of cervical ectopia and of cervicitis: age, oral contraception, specific cervical infection, smoking, and douching, *Am J Obstet Gynecol* 173:534, 1995.
494. **Manhart LE, Critchlow CW, Holmes KK, Dutro SM, Eschenbach DA, Stevens CE, Totten PA**,

Mucopurulent cervicitis and Mycoplasma genitalium, *J Infect Dis* 187:650, 2003.

495. **Tredway DR, Wortham JW Jr, Condon-Mahony M, Baker D, Shane JM**, Correlation of postcoital evaluation with in vitro sperm cervical mucus determinations and ureaplasma cultures, *Fertil Steril* 43:286, 1985.
496. **Farhi J, Valentine A, Bahadur G, Shenfield F, Steele SJ, Jacobs HS**, In-vitro cervical mucus-sperm penetration tests and outcome of infertility treatments in couples with repeatedly negative post-coital tests, *Hum Reprod* 10: 85, 1995.
497. **Keel BA, Schalue TK**, Correlation of the bovine cervical mucus penetration test with human sperm characteristics in 1,406 ejaculates, *Arch Androl* 44:109, 2000.
498. **Bateman BG, Nunley WC Jr, Kolp LA**, Exogenous estrogen therapy for the treatment of clomiphene citrate-induced cervical mucus abnormalities: Is it effective? *Fertil Steril* 54:577, 1990.
499. **Check JH, Adelson HG, Wu CH**, Improvement of cervical factor with guaifenesin, *Fertil Steril* 37:707, 1982.
500. **Ansari AH, Gould KG, Ansari VM**, Sodium bicarbonate douching for improvement of the postcoital test, *Fertil Steril* 33:608, 1980.
501. **Friedman A, Haas S, Kredentser J, Stewart E, Schiff I**, A controlled trial of intrauterine insemination for cervical factor and male factor: a preliminary report, *Int J Fertil* 34:199, 1989.
502. **Kirby CA, Flaherty SP, Godfrey BM, Warnes GM, Matthews CD**, A prospective trial of intrauterine insemination of motile spermatozoa versus timed intercourse, *Fertil Steril* 56:102, 1991.
503. **te Velde ER, van Kooy RJ, Waterreus JJ**, Intrauterine insemination of washed husband's spermatozoa: a controlled study, *Fertil Steril* 51:182, 1989.
504. **Mol BW**, Diagnostic potential of the postcoital test, In: Heineman MJ, ed. *Evidence-Based Medicine in Clinical Practice*, American Society for Reproductive Medicine, Birmingham, AL, 2001.
505. **Glatstein IZ, Harlow BL, Hornstein MD**, Practice patterns among reproductive endocrinologists: the infertility evaluation, *Fertil Steril* 67:443, 1997.
506. **Griffith CS, Grimes DA**, The validity of the postcoital test, *Am J Obstet Gynecol* 162:615, 1990.
507. **Oei SG, Bloemenkamp KW, Helmerhorst FM, Naaktgeboren N, Keirse MJ**, Evaluation of the postcoital test for assessment of 'cervical factor' infertility, *Eur J Obstet Gynecol Reprod Biol* 64:217, 1996.
508. **Oei SG, Helmerhorst FM, Bloemenkamp KW, Hollants FA, Meerpoel DE, Keirse MJ**, Effectiveness of the postcoital test: randomised controlled trial, *Br Med J* 317:502, 1998.
509. **Reuter KL, Daly DC, Cohen SM**, Septate versus bicornuate uteri: errors in imaging diagnosis, *Radiology* 172:749, 1989.
510. **Pellerito JS, McCarthy SM, Doyle MB, Glickman MG, DeCherney AH**, Diagnosis of uterine anomalies: relative accuracy of MR imaging, endovaginal sonography, and hysterosalpingography, *Radiology* 183:795, 1992.
511. **Homer HA, Li TC, Cooke ID**, The septate uterus: a review of management and reproductive outcome, *Fertil Steril* 73:1, 2000.
512. **Preutthipan S, Linasmita V**, A prospective comparative study between hysterosalpingography and hysteroscopy in the detection of intrauterine pathology in patients with infertility, *J Obstet Gynaecol Res* 29:33, 2003.
513. **Soares SR, Barbosa dos Reis MM, Camargos AF**, Diagnostic accuracy of sonohysterography, transvaginal sonography, and hysterosalpingography in patients with uterine cavity diseases, *Fertil Steril* 73:406, 2000.
514. **Breitkopf D, Goldstein SR, Seeds JW**, ACOG technology assessment in obstetrics and gynecology. Number 3, September 2003. Saline infusion sonohysterography, *Obstet Gynecol* 102:659, 2003.
515. **Sladkevicius P, Valentin L, Marsal K**, Blood flow velocity in the uterine and ovarian arteries during the normal menstrual cycle, *Ultrasound Obstet Gynecol* 3:199, 1993.
516. **Tan SL, Zaidi J, Campbell S, Doyle P, Collins W**, Blood flow changes in the ovarian and uterine arteries during the normal menstrual cycle, *Am J Obstet Gynecol* 175:625, 1996.
517. **Gonen Y, Casper RF**, Prediction of implantation by the sonographic appearance of the endometrium during controlled ovarian stimulation for in vitro fertilization (IVF), *J In Vitro Fert Embryo Transf* 7:146, 1990.



518. **Khalifa E, Brzyski RG, Oehninger S, Acosta AA, Muasher SJ**, Sonographic appearance of the endometrium: the predictive value for the outcome of in-vitro fertilization in stimulated cycles, *Hum Reprod* 7:677, 1992.
519. **Friedler S, Schenker JG, Herman A, Lewin A**, The role of ultrasonography in the evaluation of endometrial receptivity following assisted reproductive treatments: a critical review, *Hum Reprod Update* 2:323, 1996.
520. **Rashidi BH, Sadeghi M, Jafarabadi M, Tehrani Nejad ES**, Relationships between pregnancy rates following in vitro fertilization or intracytoplasmic sperm injection and endometrial thickness and pattern, *Eur J Obstet Gynecol Reprod Biol* 120:179, 2005.
521. **Merce LT, Barco MJ, Bau S, Troyano J**, Are endometrial parameters by three-dimensional ultrasound and power Doppler angiography related to in vitro fertilization/embryo transfer outcome? *Fertil Steril* 89:111, 2008.
522. **Chen SL, Wu FR, Luo C, Chen X, Shi XY, Zheng HY, Ni YP**, Combined analysis of endometrial thickness and pattern in predicting outcome of in vitro fertilization and embryo transfer: a retrospective cohort study, *Reprod Biol Endocrinol* 24:30, 2010.
523. **Steer CV, Tan SL, Mason BA, Campbell S**, Midluteal-phase vaginal color Doppler assessment of uterine artery impedance in a subfertile population, *Fertil Steril* 61:53, 1994.
524. **Tinkanen H, Kujansuu E, Laippala P**, Vascular resistance in uterine and ovarian arteries: its association with infertility and the prognosis of infertility, *Eur J Obstet Gynecol Reprod Biol* 57:111, 1994.
525. **Isaksson R, Tiitinen A, Reinikainen LM, Cacciatore B**, Comparison of uterine and spiral artery blood flow in women with unexplained and tubal infertility, *Ultrasound Obstet Gynecol* 21:174, 2003.
526. **Kelly SM, Sladkevicius P, Campbell S, Nargund G**, Investigation of the infertile couple: a one-stop ultrasound-based approach, *Hum Reprod* 16:2481, 2001.
527. **Benacerraf BR, Shipp TD, Bromley B**, Which patients benefit from a 3D reconstructed coronal view of the uterus added to standard routine 2D pelvic sonography? *AJR Am J Roentgenol* 190(3):626, 2008.
528. **Faivre E, Fernandez H, Deffieux X, Gervaise A, Frydman R, Levallant JM**, Accuracy of three-dimensional ultrasonography in differential diagnosis of septate and bicornuate uterus compared with office hysteroscopy and pelvic magnetic resonance imaging, *J Minim Invasive Gynecol* 19(1):101, 2012.
529. **Ghi T, Casadio P, Kuleva M, Perrone AM, Savelli L, Giunchi S, et al**, Accuracy of three-dimensional ultrasound in diagnosis and classification of congenital uterine anomalies, *Fertil Steril* 92(2):808, 2009.
530. **Moini A, Mohammadi S, Hosseini R, Eslami B, Ahmadi F**, Accuracy of 3-dimensional sonography for diagnosis and classification of congenital uterine anomalies, *J Ultrasound Med* 32(6):923, 2013.
531. **Becker E Jr, Lev-Toaff AS, Kaufman EP, Halpern EJ, Edelweiss MI, Kurtz AB**, The added value of transvaginal sonohysterography over transvaginal sonography alone in women with known or suspected leiomyoma, *J Ultrasound Med* 21:237, 2002.
532. **Leone FP, Lanzani C, Ferrazzi E**, Use of strict sonohysterographic methods for preoperative assessment of submucous myomas, *Fertil Steril* 79:998, 2003.
533. **Sylvestre C, Child TJ, Tulandi T, Tan SL**, A prospective study to evaluate the efficacy of two- and three-dimensional sonohysterography in women with intrauterine lesions, *Fertil Steril* 79:1222, 2003.
534. **Makris N, Kalmantis K, Skartados N, Papadimitriou A, Mantzaris G, Antsaklis A**, Three-dimensional hysterosonography versus hysteroscopy for the detection of intracavitary uterine abnormalities, *Int J Gynaecol Obstet* 97:6, 2007.
535. **Kupesic S, Kurjak A, Skenderovic S, Bjelos D**, Screening for uterine abnormalities by three-dimensional ultrasound improves perinatal outcome, *J Perinat Med* 30(1):9, 2002.
536. **La Torre R, De Felice C, De Angelis C, Coacci F, Mastrone M, Cosmi EV**, Transvaginal sonographic evaluation of endometrial polyps: a comparison with two dimensional and three dimensional contrast sonography, *Clin Exp Obstet Gynecol* 26(3-4):171, 1999.
537. **Stadtmauer L, Shah A**, Gynecologic surgery: preoperative assessment with ultrasound, *Clin Obstet Gynecol* 60(1):82, 2017.
538. **Fedele L, Bianchi S, Dorta M, Vignali M**, Intrauterine adhesions: detection with transvaginal US, *Radiology* 199:757, 1996.
539. **Salle B, Gaucherand P, de Saint Hilaire P, Rudigoz RC**, Transvaginal sonohysterographic evaluation of

intrauterine adhesions, *J Clin Ultrasound* 27:131, 1999.

540. **Davis PC, O'Neill MJ, Yoder IC, Lee SI, Mueller PR**, Sonohysterographic findings of endometrial and subendometrial conditions, *Radiographics* 22:803, 2002.
541. **Karayalcin R, Ozcan S, Moraloglu O, Ozyer S, Mollamahmutoglu L, Batioglu S**, Results of 2500 office-based diagnostic hysteroscopies before IVF, *Reprod Biomed Online* 20:689, 2010.
542. **Simon C, Martinez L, Pardo F, Tortajada M, Pellicer A**, Mullerian defects in women with normal reproductive outcome, *Fertil Steril* 56:1192, 1991.
543. **Acién P**, Incidence of Müllerian defects in fertile and infertile women, *Hum Reprod* 12:1372, 1997.
544. **Ashton D, Amin HK, Richart RM, Neuwirth RS**, The incidence of asymptomatic uterine anomalies in women undergoing transcervical tubal sterilization, *Obstet Gynecol* 72:28, 1988.
545. **Raga F, Bauset C, Remohi J, Bonilla-Musoles F, Simón C, Pellicer A**, Reproductive impact of congenital Müllerian anomalies, *Hum Reprod* 12:2277, 1997.
546. **Jurkovic D, Gruboeck K, Tailor A, Nicolaidis KH**, Ultrasound screening for congenital uterine anomalies, *Br J Obstet Gynaecol* 104:1320, 1997.
547. **Grimbizis GF, Camus M, Tarlatzis BC, Bontis JN, Devroey P**, Clinical implications of uterine malformations and hysteroscopic treatment results, *Hum Reprod Update* 7:161, 2001.
548. **Chan YY, Jayaprakasan K, Zamora J, Thornton JG, Raine-Fenning N, Coomarasamy A**, The prevalence of congenital uterine anomalies in unselected and high-risk populations: a systematic review, *Hum Reprod Update* 17:761, 2011.
549. **Practice Committee of the American Society of Reproductive Medicine**, Uterine septum: a guideline, *Fertil Steril* 106:530, 2016.
550. **Venetis CA, Papadopoulos SP, Campo R, Gordts S, Tarlatzis BC, Grimbizis GF**, Clinical implications of congenital uterine anomalies: a meta-analysis of comparative studies, *Reprod Biomed Online* 29:665, 2014.
551. **Burchell RC, Creed F, Rasoulpour M, Whitcomb M**, Vascular anatomy of the human uterus and pregnancy wastage, *Br J Obstet Gynaecol* 85:698, 1978.
552. **Candiani GB, Fedele L, Zamberletti D, De Virgiliis D, Carinelli S**, Endometrial patterns in malformed uteri, *Acta Eur Fertil* 14:311, 1983.
553. **Rock JA, Murphy AA**, Anatomic abnormalities, *Clin Obstet Gynecol* 29:886, 1986.
554. **Fedele L, Bianchi S, Marchini M, Franchi D, Tozzi L, Dorta M**, Ultrastructural aspects of endometrium in infertile women with septate uterus, *Fertil Steril* 65:750, 1996.
555. **Valle RF, Ekpo GE**, Hysteroscopic metroplasty for the septate uterus: a review and meta-analysis, *J Minim Invasive Gynecol* 20:22, 2013.
556. **Colacurci N, De Franciscis P, Fornaro F, Fortunato N, Perino A**, The significance of hysteroscopic treatment of congenital uterine malformations, *Reprod Biomed Online* 4(Suppl 3):52, 2002.
557. **Baird DD, Dunson DB, Hill MC, Cousins D, Schetman JM**, High cumulative incidence of uterine leiomyoma in black and white women: ultrasound evidence, *Am J Obstet Gynecol* 188:100, 2003.
558. **Cramer SF, Patel A**, The frequency of uterine leiomyomas, *Am J Clin Pathol* 94:435, 1990.
559. **Practice Committee of the American Society of Reproductive Medicine**, Removal of myomas in asymptomatic patients to improve fertility and/or reduce miscarriage rate: a guideline, *Fertil Steril* 108:416, 2017.
560. **Practice Committee of the American Society for Reproductive Medicine**, Myomas and reproductive function, *Fertil Steril* 90(Suppl 5):125, 2008.
561. **Deligdisch L, Loewenthal M**, Endometrial changes associated with myomata of the uterus, *J Clin Pathol* 23:676, 1970.
562. **Sharma SP, Misra SD, Mittal VP**, Endometrial changes—a criterion for the diagnosis of submucous uterine leiomyoma, *Indian J Pathol Microbiol* 22:33, 1979.
563. **Maguire M, Segars J**, Benign uterine disease: leiomyomata and benign polyps, In: April JD, et al., eds. *The Endometrium: Molecular, Cellular and Clinical Perspectives*, Informa HealthCare, London, UK, 2008, p. 797.
564. **Rackow BW, Taylor HS**, Submucosal uterine leiomyomas have a global effect on molecular determinants of endometrial receptivity, *Fertil Steril* 93:2027, 2010.

565. **Horcajadas JA, Goyri E, Higon MA, Martinez-Conejero JA, Gambadauro P, Garcia G, Meseguer M, Simon C, Pellicer A**, Endometrial receptivity and implantation are not affected by the presence of uterine intramural leiomyomas: a clinical and functional genomics analysis, *J Clin Endocrinol Metab* 93(9):3490, 2008.
566. **Farhi J, Ashkenazi J, Feldberg D, Dicker D, Orvieto R, Ben Rafael Z**, Effect of uterine leiomyomata on the results of in-vitro fertilization treatment, *Hum Reprod* 10:2576, 1995.
567. **Eldar-Geva T, Meagher S, Healy DL, MacLachlan V, Breheny S, Wood C**, Effect of intramural, subserosal, and submucosal uterine fibroids on the outcome of assisted reproductive technology treatment, *Fertil Steril* 70:687, 1998.
568. **Stovall DW, Parrish SB, Van Voorhis BJ, Hahn SJ, Sparks AE, Syrop CH**, Uterine leiomyomas reduce the efficacy of assisted reproduction cycles: results of a matched follow-up study, *Hum Reprod* 13:192, 1998.
569. **Hart R, Khalaf Y, Yeong CT, Seed P, Taylor A, Braude P**, A prospective controlled study of the effect of intramural uterine fibroids on the outcome of assisted conception, *Hum Reprod* 16:2411, 2001.
570. **Khalaf Y, Ross C, El-Toukhy T, Hart R, Seed P, Braude P**, The effect of small intramural uterine fibroids on the cumulative outcome of assisted conception, *Hum Reprod* 21:2640, 2006.
571. **Somigliana E, De Benedictis S, Vercellini P, Nicolosi AE, Benaglia L, Scarduelli C, Ragni C, Fedele L**, Fibroids not encroaching the endometrial cavity and IVF success rate: a prospective study, *Hum Reprod* 26:834, 2011.
572. **Christopoulos G, Vlismas A, Salim R, Islam R, Trew G, Lavery S**, Fibroids that do not distort the uterine cavity and IVF success rates: an observational study using extensive matching criteria, *BJOG* 124:615, 2017.
573. **Ezzati M, Norian JM, Segars JH**, Management of uterine fibroids in the patient pursuing assisted reproductive technologies, *Womens Health (Lond)* 5:413, 2009.
574. **Benecke C, Kruger TF, Siebert TI, Van der Merwe JP, Steyn DW**, Effect of fibroids on fertility in patients undergoing assisted reproduction. A structured literature review, *Gynecol Obstet Invest* 59:225, 2005.
575. **Somigliana E, Vercellini P, Daguati R, Pasin R, De Giorgi O, Crosignani PG**, Fibroids and female reproduction: a critical analysis of the evidence, *Hum Reprod Update* 13:465, 2007.
576. **Klatsky PC, Tran ND, Caughey AB, Fujimoto VY**, Fibroids and reproductive outcomes: a systematic literature review from conception to delivery, *Am J Obstet Gynecol* 198:357, 2008.
577. **Pritts EA, Parker WH, Olive DL**, Fibroids and infertility: an updated systematic review of the evidence, *Fertil Steril* 91:1215, 2009.
578. **Hartmann KE, Velez Edwards DR, Savitz DA, Jonsson-Funk ML, Wu P, Sundermann AC, Baird DD**, Prospective cohort study of uterine fibroids and miscarriage risk, *Am J Epidemiol* 186:1140, 2017.
579. **Healy DL**, Impact of uterine fibroids on ART outcome, *Environ Health Perspect* 108(Suppl 5):845, 2000.
580. **Dietterich C, Check JH, Choe JK, Nazari A, Fox F**, The presence of small uterine fibroids not distorting the endometrial cavity does not adversely affect conception outcome following embryo transfer in older recipients, *Clin Exp Obstet Gynecol* 27:168, 2000.
581. **Jun SH, Ginsburg ES, Racowsky C, Wise LA, Hornstein MD**, Uterine leiomyomas and their effect on in vitro fertilization outcome: a retrospective study, *J Assist Reprod Genet* 18:139, 2001.
582. **Surrey ES, Lietz AK, Schoolcraft WB**, Impact of intramural leiomyomata in patients with a normal endometrial cavity on in vitro fertilization-embryo transfer cycle outcome, *Fertil Steril* 75:405, 2001.
583. **Check JH, Choe JK, Lee G, Dietterich C**, The effect on IVF outcome of small intramural fibroids not compressing the uterine cavity as determined by a prospective matched control study, *Hum Reprod* 17:1244, 2002.
584. **Oliveira FG, Abdelmassih VG, Diamond MP, Dozortsev D, Melo NR, Abdelmassih R**, Impact of subserosal and intramural uterine fibroids that do not distort the endometrial cavity on the outcome of in vitro fertilization-intracytoplasmic sperm injection, *Fertil Steril* 81:582, 2004.
585. **Sunkara SK, Khairy M, El-Toukhy T, Khalaf Y, Coomarassamy A**, The effect of intramural fibroids without uterine cavity involvement on the outcome of IVF treatment: a systematic review and meta-analysis, *Hum Reprod* 25:418, 2010.
586. **Casini ML, Rossi F, Agostini R, Unfer V**, Effects of the position of fibroids on fertility, *Gynecol Endocrinol* 22:106, 2006.

587. **Bulletti C, De Ziegler D, Polli V, Flamigni C**, The role of leiomyomas in infertility, *J Am Assoc Gynecol Laparosc* 6:441, 1999.
588. **Aboulghar MM, Al-Inany HG, Aboulghar MA, Serour GI, Mansour RT**, The effect of intramural fibroids on the outcome of IVF, *Middle East Fertil Soc J* 9:263, 2004.
589. **Seoud M, Patterson R, Musher S, Coddington C**, Effects of myoma or prior myomectomy on In Vitro Fertilization (IVF) performance, *J Assist Reprod Genet* 9:217, 1992.
590. **Bulletti C, DE Ziegler D, Levi Setti P, Cicinelli E, Polli V, Stefanetti M**, Myomas, pregnancy outcome, and in vitro fertilization, *Ann N Y Acad Sci* 1034:84, 2004.
591. **Fauconnier A, Dubuisson JB, Ancel PY, Chapron C**, Prognostic factors of reproductive outcome after myomectomy in infertile patients, *Hum Reprod* 15:1751, 2000.
592. **Dubuisson JB, Fauconnier A, Chapron C, Kreiker G, Norgaard C**, Second look after laparoscopic myomectomy, *Hum Reprod* 13:2102, 1998.
593. **Lieng M, Istre O, Langebrekke A**, Uterine rupture after laparoscopic myomectomy, *J Am Assoc Gynecol Laparosc* 11:92, 2004.
594. **Banas T, Klimek M, Fugiel A, Skotniczny K**, Spontaneous uterine rupture at 35 weeks' gestation, 3 years after laparoscopic myomectomy, without signs of fetal distress, *J Obstet Gynaecol Res* 31:527, 2005.
595. **Grande N, Catalano GF, Ferrari S, Marana R**, Spontaneous uterine rupture at 27 weeks of pregnancy after laparoscopic myomectomy, *J Minim Invasive Gynecol* 12:301, 2005.
596. **Parker WH, Iacampo K, Long T**, Uterine rupture after laparoscopic removal of a pedunculated myoma, *J Minim Invasive Gynecol* 14:362, 2007.
597. **Taylor HS**, Fibroids: when should they be removed to improve in vitro fertilization success? *Fertil Steril* 109(5):784, 2018.
598. **Advincula AP, Song A**, The role of robotic surgery in gynecology, *Curr Opin Obstet Gynecol* 19:331, 2007.
599. **Palomba S, Zupi E, Falbo A, Russo T, Marconi D, Tolino A, Manguso F, Mattei A, Zullo F**, A multicenter randomized, controlled study comparing laparoscopic versus minilaparotomic myomectomy: reproductive outcomes, *Fertil Steril* 88:933, 2007.
600. **Holloway RW, Patel SD, Ahmad S**, Robotic surgery in gynecology, *Scand J Surg* 98:96, 2009.
601. **Luciano AA**, Myomectomy, *Clin Obstet Gynecol* 52:362, 2009.
602. **Agdi M, Tulandi T**, Minimally invasive approach for myomectomy, *Semin Reprod Med* 28:228, 2010.
603. **Al-Inany H**, Intrauterine adhesions. An update, *Acta Obstet Gynecol Scand* 80:986, 2001.
604. **Yu D, Wong YM, Cheong Y, Xia E, Li TC**, Asherman syndrome—one century later, *Fertil Steril* 89:759, 2008.
605. **Berman JM**, Intrauterine adhesions, *Semin Reprod Med* 26:349, 2008.
606. **Thomson AJ, Abbott JA, Deans R, Kingston A, Vancaillie TG**, The management of intrauterine synechiae, *Curr Opin Obstet Gynecol* 21:335, 2009.
607. **Jensen PA, Stromme WB**, Amenorrhea secondary to puerperal curettage (Asherman's syndrome), *Am J Obstet Gynecol* 113:150, 1972.
608. **Romer T**, Post-abortion-hysteroscopy—a method for early diagnosis of congenital and acquired intrauterine causes of abortions, *Eur J Obstet Gynecol Reprod Biol* 57:171, 1994.
609. **Taylor PJ, Cumming DC, Hill PJ**, Significance of intrauterine adhesions detected hysteroscopically in eumenorrhic infertile women and role of antecedent curettage in their formation, *Am J Obstet Gynecol* 139:239, 1981.
610. **Shaffer W**, Role of uterine adhesions in the cause of multiple pregnancy losses, *Clin Obstet Gynecol* 29:912, 1986.
611. **Schenker JG**, Etiology of and therapeutic approach to synechia uteri, *Eur J Obstet Gynecol Reprod Biol* 65:109, 1996.
612. **Tripathy SN**, Infertility and pregnancy outcome in female genital tuberculosis, *Int J Gynaecol Obstet* 76:159, 2002.
613. **Westendorp IC, Ankum WM, Mol BW, Vonk J**, Prevalence of Asherman's syndrome after secondary removal of placental remnants or a repeat curettage for incomplete abortion, *Hum Reprod* 13:3347, 1998.

614. **Friedler S, Margalioth EJ, Kafka I, Yaffe H**, Incidence of post-abortion intra-uterine adhesions evaluated by hysteroscopy—a prospective study, *Hum Reprod* 8:442, 1993.
615. **Roma Dalfo A, Ubeda B, Ubeda A, Monzon M, Rotger R, Ramos R, Palacio A**, Diagnostic value of hysterosalpingography in the detection of intrauterine abnormalities: a comparison with hysteroscopy, *AJR Am J Roentgenol* 183:1405, 2004.
616. **Schenker JG, Margalioth EJ**, Intrauterine adhesions: an updated appraisal, *Fertil Steril* 37:593, 1982.
617. **Practice Committee of the American Association of Gynecological Laparoscopists**, Practice guidelines on intrauterine adhesions developed in collaboration with the European Society of Gynaecological Endoscopy (ESGE), *J Minim Invasive Gynecol* 24:695, 2017.
618. **Kresowik JD, Syrop CH, Van Voorhis BJ, Ryan GL**, Ultrasound is the optimal choice for guidance in difficult hysteroscopy, *Ultrasound Obstet Gynecol* 39:715, 2012.
619. **Tasma ML, Louwerse MD, Hehenkamp WJ, Geomini PM, Bongers MY, Veersema S, van Kesteren PJ, Tromp E, Huirne JA, Graziosi GC**, Misoprostol for cervical priming prior to hysteroscopy in postmenopausal and premenopausal nulliparous women; a multicentre randomised placebo controlled trial, *BJOG* 125:81, 2018.
620. **Cooper JM, Brady RM**, Late complications of operative hysteroscopy, *Obstet Gynecol Clin North Am* 27:367, 2000.
621. **American Association of Gynecologic Laparoscopists**, Practice guidelines for management of intrauterine synechiae, *J Minim Invasive Gynecol* 17:1, 2010.
622. **Coccia ME, Becattini C, Bracco GL, Pampaloni F, Bargelli G, Scarselli G**, Pressure lavage under ultrasound guidance: a new approach for outpatient treatment of intrauterine adhesions, *Fertil Steril* 75:601, 2001.
623. **Karande V, Levrant S, Hoxsey R, Rinehart J, Gleicher N**, Lysis of intrauterine adhesions using gynecoradiologic techniques, *Fertil Steril* 68:658, 1997.
624. **March CM**, Intrauterine adhesions, *Obstet Gynecol Clin North Am* 22:491, 1995.
625. **Pistofidis GA, Dimitropoulos K, Mastrominas M**, Comparison of operative and fertility outcome between groups of women with intrauterine adhesions after adhesiolysis, *J Am Assoc Gynecol Laparosc* 3:S40, 1996.
626. **Lindheim SR, Kavic S, Shulman SV, Sauer MV**, Operative hysteroscopy in the office setting, *J Am Assoc Gynecol Laparosc* 7:65, 2000.
627. **Goldenberg M, Sivan E, Sharabi Z, Bider D, Rabinovici J, Seidman DS**, Outcome of hysteroscopic resection of submucous myomas for infertility, *Fertil Steril* 64:714, 1995.
628. **Katz Z, Ben-Arie A, Lurie S, Manor M, Insler V**, Reproductive outcome following hysteroscopic adhesiolysis in Asherman's syndrome, *Int J Fertil Menopausal Stud* 41:462, 1996.
629. **Capella-Allouc S, Morsad F, Rongieres-Bertrand C, Taylor S, Fernandez H**, Hysteroscopic treatment of severe Asherman's syndrome and subsequent fertility, *Hum Reprod* 14:1230, 1999.
630. **Zikopoulos KA, Kolibianakis EM, Platteau P, de Munck L, Tournaye H, Devroey P, Camus M**, Live delivery rates in subfertile women with Asherman's syndrome after hysteroscopic adhesiolysis using the resectoscope or the Versapoint system, *Reprod Biomed Online* 8:720, 2004.
631. **Kodaman PH**, Hysteroscopic polypectomy for women undergoing IVF treatment: when is it necessary? *Curr Opin Gynecol Obstet* 28:184, 2016.
632. **Lass A, Williams G, Abusheikha N, Brinsden P**, The effect of endometrial polyps on outcomes of in vitro fertilization (IVF) cycles, *J Assist Reprod Genet* 16:410, 1999.
633. **Shokeir TA, Shalan HM, El-Shafei MM**, Significance of endometrial polyps detected hysteroscopically in eumenorrhic infertile women, *J Obstet Gynaecol Res* 30:84, 2004.
634. **Jovanovic AS, Boynton KA, Mutter GL**, Uteri of women with endometrial carcinoma contain a histopathological spectrum of monoclonal putative precancers, some with microsatellite instability, *Cancer Res* 56:1917, 1996.
635. **Pal L, Niklaus AL, Kim M, Pollack S, Santoro N**, Heterogeneity in endometrial expression of aromatase in polyp-bearing uteri, *Hum Reprod* 23:80, 2008.
636. **Dal Cin P, Vanni R, Marras S, Moerman P, Kools P, Andria M, Valdes E, Deprest J, Van de Ven W**,

- Van den Berghe H**, Four cytogenetic subgroups can be identified in endometrial polyps, *Cancer Res* 55:1565, 1995.
637. **Kamel HS, Darwish AM, Mohamed SA**, Comparison of transvaginal ultrasonography and vaginal sonohysterography in the detection of endometrial polyps, *Acta Obstet Gynecol Scand* 79:60, 2000.
638. **Lindheim SR, Morales AJ**, Comparison of sonohysterography and hysteroscopy: lessons learned and avoiding pitfalls, *J Am Assoc Gynecol Laparosc* 9:223, 2002.
639. **Mittal K, Schwartz L, Goswami S, Demopoulos R**, Estrogen and progesterone receptor expression in endometrial polyps, *Int J Gynecol Pathol* 15:345, 1996.
640. **Spiewankiewicz B, Stelmachow J, Sawicki W, Cendrowski K, Wypych P, Swiderska K**, The effectiveness of hysteroscopic polypectomy in cases of female infertility, *Clin Exp Obstet Gynecol* 30:23, 2003.
641. **Perez-Medina T, Bajo-Arenas J, Salazar F, Redondo T, Sanfrutos L, Alvarez P, Engels V**, Endometrial polyps and their implication in the pregnancy rates of patients undergoing intrauterine insemination: a prospective, randomized study, *Hum Reprod* 20:1632, 2005.
642. **Isikoglu M, Berkkanoglu M, Senturk Z, Coetsee K, Ozgur K**, Endometrial polyps smaller than 1.5 cm do not affect ICSI outcome, *Reprod Biomed Online* 12:199, 2006.
643. **Shohayeb A Shaltout A**, Persistent endometrial polyps may affect the pregnancy rate in patients undergoing intrauterine insemination, *Middle East Fertil Soc J* 16:259, 2011.
644. **Bosteels J, Kasius J, Weyers S, et al.**, Hysteroscopy for treating subfertility associated with suspected major uterine cavity abnormalities, *Cochrane Database Syst Rev* (2):CD009461, 2015.
645. **Mouhayar Y, Yin O, Mumford SL, Segars JH**, Hysteroscopic polypectomy prior to infertility treatment: a cost analysis and systematic review, *Eur J Obstet Gynecol Reprod Biol* 213:107, 2017.
646. **Affi K, Anand S, Nallapeta S, Gelbaya TA**, Management of endometrial polyps in subfertile women: a systematic review, *Eur J Obstet Gynecol Reprod Biol* 151:117, 2010.
647. **Lieng M, Istre O, Qvigstad E**, Treatment of endometrial polyps: a systematic review, *Acta Obstet Gynecol Scand* 89:992, 2010.
648. **Czernobilsky B**, Endometritis and infertility, *Fertil Steril* 30:119, 1978.
649. **Paavonen J, Kiviat N, Brunham RC, Stevens CE, Kuo CC, Stamm WE, Miettinen A, Soules M, Eschenbach DA, Holmes KK**, Prevalence and manifestations of endometritis among women with cervicitis, *Am J Obstet Gynecol* 152:280, 1985.
650. **Korn AP, Hessol N, Padian N, Bolan G, Muzsnai D, Donegan E, Jonte J, Schachter J, Landers DV**, Commonly used diagnostic criteria for pelvic inflammatory disease have poor sensitivity for plasma cell endometritis, *Sex Transm Dis* 22:335, 1995.
651. **Korn AP, Bolan G, Padian N, Ohm-Smith M, Schachter J, Landers DV**, Plasma cell endometritis in women with symptomatic bacterial vaginosis, *Obstet Gynecol* 85:387, 1995.
652. **Wiesenfeld HC, Hillier SL, Krohn MA, Amortegui AJ, Heine RP, Landers DV, Sweet RL**, Lower genital tract infection and endometritis: insight into subclinical pelvic inflammatory disease, *Obstet Gynecol* 100:456, 2002.
653. **Polisseni F, Bambirra EA, Camargos AF**, Detection of chronic endometritis by diagnostic hysteroscopy in asymptomatic infertile patients, *Gynecol Obstet Invest* 55:205, 2003.
654. **Paukku M, Puolakkainen M, Paavonen T, Paavonen J**, Plasma cell endometritis is associated with Chlamydia trachomatis infection, *Am J Clin Pathol* 112:211, 1999.
655. **Mount S, Mead P, Cooper K**, Chlamydia trachomatis in the endometrium: can surgical pathologists identify plasma cells? *Adv Anat Pathol* 8:327, 2001.
656. **Taylor-Robinson D**, Mycoplasma genitalium—an up-date, *Int J STD AIDS* 13:145, 2002.
657. **Cicinelli E, Matteo M, Trojano G, Mitola PC, Tinelli R, Vitagliano A, Crupano FM, Lepera A, Miragliotta G, Resta L**, Chronic endometritis in patients with unexplained infertility: prevalence and effects of antibiotic treatment on spontaneous conception, *Am J Reprod Immunol* 79:e12782, 2018.
658. **Cicinelli E, Matteo M, Tinelli R, Lepera A, Alfonso R, Indraccolo U, Marrocchella S, Greco P, Resta L**, Prevalence of chronic endometritis in repeated unexplained implantation failure and the IVF success rate after antibiotic therapy, *Hum Reprod* 30:323, 2015.

659. **Kasius JC, Fatemi HM, Bourgain C, Sie-Go DM, Eijkemans RJ, Fauser BC, Devroey P, Broekmans FJ**, The impact of chronic endometritis on reproductive outcome, *Fertil Steril* 96:1451, 2011.
660. **Honore GM, Holden AE, Schenken RS**, Pathophysiology and management of proximal tubal blockage, *Fertil Steril* 71:785, 1999.
661. **Westrom L**, Effect of acute pelvic inflammatory disease on fertility, *Am J Obstet Gynecol* 121:707, 1975.
662. **Westrom I**, Incidence, prevalence, and trends of acute pelvic inflammatory disease and its consequences in industrialized countries, *Am J Obstet Gynecol* 138:880, 1980.
663. **Westrom L, Joesoef R, Reynolds G, Hagdu A, Thompson SE**, Pelvic inflammatory disease and fertility, *Sex Trans Dis* 19:185, 1992.
664. **Westrom LV**, Sexually transmitted diseases and infertility, *Sex Transm Dis* 21:S32, 1994.
665. **Westrom L**, Effect of pelvic inflammatory disease on fertility, *Venereology* 8:219, 1995.
666. **Mohiyiddeen L, Hardiman A, Fitzgerald C, Hughes E, Mol BW, Johnson N, Watson A**, Tubal flushing for subfertility, *Cochrane Database Syst Rev* (5):CD003718, 2015.
667. **Forsey JP, Caul EO, Paul ID, Hull MG**, Chlamydia trachomatis, tubal disease and the incidence of symptomatic and asymptomatic infection following hysterosalpingography, *Hum Reprod* 5:444, 1990.
668. **Uzun O, Findik S, Danaci M, Katar D, Erkan L**, Pulmonary and cerebral oil embolism after hysterosalpingography with oil soluble contrast medium, *Respirology* 9:134, 2004.
669. **Ma G, Mao R, Zhai H**, Hyperthyroidism secondary to hysterosalpingography: an extremely rare complication: a case report, *Medicine (Baltimore)* 95:e5588, 2016.
670. **Dabekausen YA, Evers JL, Land JA, Stals FS**, Chlamydia trachomatis antibody testing is more accurate than hysterosalpingography in predicting tubal factor infertility, *Fertil Steril* 61:833, 1994.
671. **Mol BW, Dijkman B, Wertheim P, Lijmer J, van der Veen F, Bossuyt PM**, The accuracy of serum chlamydial antibodies in the diagnosis of tubal pathology: a meta-analysis, *Fertil Steril* 67:1031, 1997.
672. **Thomas K, Coughlin L, Mannion PT, Haddad NG**, The value of Chlamydia trachomatis antibody testing as part of routine infertility investigations, *Hum Reprod* 15:1079, 2000.
673. **Veenemans LM, van der Linden PJ**, The value of Chlamydia trachomatis antibody testing in predicting tubal factor infertility, *Hum Reprod* 17:695, 2002.
674. **Hindocha A, Beere L, O'Flynn H, Watson A, Ahmad G**, Pain relief in hysterosalpingography, *Cochrane Database Syst Rev* (9):CD006106, 2015.
675. **Karaman E, Cim N, Alkis I, Yildirim A, Yildizhan R**, Rectal indomethacin use in pain relief during hysterosalpingography: a randomized placebo controlled trial, *J Obstet Gynaecol Res* 42:195, 2016.
676. **Stumpf PG, March CM**, Febrile morbidity following hysterosalpingography: identification of risk factors and recommendations for prophylaxis, *Fertil Steril* 33:487, 1980.
677. **Pittaway DE, Winfield AC, Maxson W, Daniell J, Herbert C, Wentz AC**, Prevention of acute pelvic inflammatory disease after hysterosalpingography: efficacy of doxycycline prophylaxis, *Am J Obstet Gynecol* 147:623, 1983.
678. **Perisinakis K, Damilakis J, Grammatikakis J, Theocharopoulos N, Gourtsoyiannis N**, Radiogenic risks from hysterosalpingography, *Eur Radiol* 13:1522, 2003.
679. **Tur-Kaspa I, Seidman DS, Soriano D, Greenberg I, Dor J, Bider D**, Hysterosalpingography with a balloon catheter versus a metal cannula: a prospective, randomized, blinded comparative study, *Hum Reprod* 13:75, 1998.
680. **Ricci G, Guastalla P, Ammar L, Cervi G, Guarnieri S, Sartore A**, Balloon catheter vs. cervical vacuum cup for hysterosalpingography: a prospective, randomized, single-blinded study, *Fertil Steril* 87:1458, 2007.
681. **Cohen SB, Wattiez A, Seidman DS, Lidor AL, Hendler, Rabinovichi J, Goldenberg M**, Comparison of cervical vacuum cup cannula with metal cannula for hysterosalpingography, *BJOG* 108:1031, 2001.
682. **Lindequist S, Justesen P, Larsen C, Rasmussen F**, Diagnostic quality and complications of hysterosalpingography: oil- versus water-soluble contrast media—a randomized prospective study, *Radiology* 179:69, 1991.
683. **Moore DE, Segars JH Jr, Winfield AC, Page DL, Eisenberg AD, Holburn GE**, Effects of contrast agents on the fallopian tube in a rabbit model, *Radiology* 176:721, 1990.

684. **Grossinsky CM, Clark RL, Wilson PA, Novotny DB**, Pelvic granulomata mimicking endometriosis following the administration of oil-based contrast media for hysterosalpingography, *Obstet Gynecol* 83:890, 1994.
685. **Nunley WC Jr, Bateman BG, Kitchin JD III, Pope TL Jr**, Intravasation during hysterosalpingography using oil-base contrast medium—a second look, *Obstet Gynecol* 70:309, 1987.
686. **Dreyer K, van Rijswijk J, Mijatovic V, Goddijn M, Verhoeve HR, van Rooij IAJ, Hoek A, Bourdrez P, Nap AW, Rijnsaardt-Lukassen HGM, Timmerman CCM, Kaplan M, Hooker AB, Gijsen AP, van Golde R, van Heteren CF, Sluijmer AV, de Bruin JP, Smeenk MJ, de Boer JAM, Scheenjes E, Duijn AEJ, Mozes A, Pelinck MJ, Traas MAF, van Hooff MHA, van Unnik GA, de Koning CH, van Geloven N, Twisk JWR, Hompes PGA, Mol BWJ**, Oil-based or water-based contrast for hysterosalpingography in infertile women, *N Engl J Med* 25:2043, 2017.
687. **Mol BW, Swart P, Bossuyt PM, van der Veen F**, Is hysterosalpingography an important tool in predicting fertility outcome? *Fertil Steril* 67:663, 1997.
688. **Mol BW, Collins JA, Burrows EA, van der Veen F, Bossuyt PM**, Comparison of hysterosalpingography and laparoscopy in predicting fertility outcome, *Hum Reprod* 14:1237, 1999.
689. **Maheux-Lacroix S, Boutin A, Moore L, Bergeron ME, Bujold E, Laberge P, Lemyre M, Dodin S**, Hysterosalpingosonography for diagnosing tubal occlusion in subfertile women: a systematic review with meta-analysis, *Hum Reprod* 29:953, 2014.
690. **Evers JLH, Land JA, Mol BW**, Evidence-based medicine for diagnostic questions, *Semin Reprod Med* 21:9, 2003.
691. **Dessole S, Meloni GB, Capobianco G, Manzoni MA, Ambrosini G, Canalis GC**, A second hysterosalpingography reduces the use of selective technique for treatment of a proximal tubal obstruction, *Fertil Steril* 73:1037, 2000.
692. **Swart P, Mol BW, van der Veen F, van Beurden M, Redekop WK, Bossuyt PM**, The accuracy of hysterosalpingography in the diagnosis of tubal pathology: a meta-analysis, *Fertil Steril* 64:486, 1995.
693. **Coppus SF, Opmeer BC, Logan S, van der Veen F, Bhattacharya S, Mol BW**, The predictive value of medical history taking and Chlamydia IgG ELISA anti- body testing (CAT) in the selection of subfertile women for diagnostic laparoscopy: a clinical prediction model approach, *Hum Reprod* 22:1353, 2007.
694. **Mol BW, Swart P, Bossuyt PM, van Beurden M, van der Veen F**, Reproducibility of the interpretation of hysterosalpingography in the diagnosis of tubal pathology, *Hum Reprod* 11:1204, 1996.
695. **Glatstein IZ, Sleeper LA, Lavy Y, Simon A, Adoni A, Palti Z, Hurwitz A, Laufer N**, Observer variability in the diagnosis and management of the hysterosalpingogram, *Fertil Steril* 67:233, 1997.
696. **Bilgin H, Ozcan B, Bilgin T**, Methemoglobinemia induced by methylene blue perturbation during laparoscopy, *Acta Anaesthesiol Scand* 42:594, 1998.
697. **Mhaskar R, Mhaskar AM**, Methemoglobinemia following chromopertubation in treated pelvic tuberculosis, *Int J Gynaecol Obstet* 77:41, 2002.
698. **Maas JW, Evers JL, ter Riet G, Kessels AG**, Pregnancy rate following normal versus abnormal hysterosalpingography findings: a meta-analysis, *Gynecol Obstet Invest* 43:79, 1997.
699. **Lim SL, Jung JJ, Yu SL, Rajesh H**, A comparison of hysterosalpingo-foam sonography (HyFoSy) and hysterosalpingo-contrast sonography with saline medium (HyCoSy) in the assessment of tubal patency, *Eur J Obstet Gynecol Reprod Biol* 195:168, 2015.
700. **Alcázar JL, Martinez-Astorquiza Corral T, Orozco R, Dominguez-Piriz J, Juez L, Errasti T**, Three-dimensional hysterosalpingo-contrast-sonography for the assessment of tubal patency in women with infertility: a systematic review with meta-analysis, *Gynecol Obstet Invest* 81:289, 2016.
701. **Piccioni MG, Riganelli L, Filippi V, Fuggetta E, Colagiovanni V, Imperiale L, Caccetta J, Panici PB, Porpora MG**, Sonohysterosalpingography: comparison of foam and saline solution, *J Clin Ultrasound* 45:67, 2017.
702. **He Y, Ma X, Xu J, Li S, Wu H, Liu Q, Kong L, Luo J, Liu H**, Comparison of assessment methods for fallopian tubal patency and peritubal adhesion between transvaginal 4-dimensional hysterosalpingo-contrast sonography and laparoscopic chromopertubation, *J Ultrasound Med* 36:547, 2017.



703. **Land JA, Evers JL, Goossens VJ**, How to use Chlamydia antibody testing in subfertility patients, *Hum Reprod* 13:1094, 1998.
704. **Jones CS, Maple PA, Andrews NJ, Paul ID, Caul EO**, Measurement of IgG antibodies to Chlamydia trachomatis by commercial enzyme immunoassays and immunofluorescence in sera from pregnant women and patients with infertility, pelvic inflammatory disease, ectopic pregnancy, and laboratory diagnosed Chlamydia psittaci/Chlamydia pneumoniae infection, *J Clin Pathol* 56: 225, 2003.
705. **Land JA, Gijzen AP, Kessels AG, Slobbe ME, Bruggeman CA**, Performance of five serological chlamydia antibody tests in subfertile women, *Hum Reprod* 18:2621, 2003.
706. **Johnson NP, Taylor K, Nadgir AA, Chinn DJ, Taylor PJ**, Can diagnostic laparoscopy be avoided in routine investigation for infertility? *Br J Obstet Gynaecol* 107:174, 2000.
707. **Akande VA, Hunt LP, Cahill DJ, Caul EO, Ford WC, Jenkins JM**, Tubal damage in infertile women: prediction using chlamydia serology, *Hum Reprod* 18:1841, 2003.
708. **The Practice Committee of the American Society for Reproductive Medicine**, Role of tubal surgery in the era of assisted reproductive technology: a committee opinion, *Fertil Steril* 103:e37, 2015.
709. **Broeze KA, Opmeer BC, Coppus SF, Van Geloven N, Den Hartog JE, Land JA, Van der Linden PJ, Ng EH, Van der Steeg JW, Steures P, Van der Veen F, Mol BW**, Integration of patient characteristics and the results of Chlamydia antibody testing and hysterosalpingography in the diagnosis of tubal pathology: an individual patient data meta-analysis, *Hum Reprod* 27:2979, 2012.
710. **Turkgeldi E, Yagmur H, Seyhan A, Urman B, Ata B**, Short and long term outcomes of children conceived with assisted reproductive technology, *Eur J Obstet Gynecol Reprod Biol* 207:129, 2016.
711. **Borrero SB, Reeves MF, Schwarz EB, Bost JE, Creinin MD, Ibrahim SA**, Race, insurance status, and desire for tubal sterilization reversal, *Fertil Steril* 90:272, 2008
712. **Schmidt JE, Hillis SD, Marchbanks PA, Jeng G, Peterson HB**, Requesting information about and obtaining reversal after tubal sterilization: findings from the U.S. Collaborative Review of Sterilization, *Fertil Steril* 74:892, 2000.
713. **Chi IC, Jones DB**, Incidence, risk factors, and prevention of poststerilization regret in women: an updated international review from an epidemiological perspective, *Obstet Gynecol Surv* 49:722, 1994.
714. **Neuhaus W, Bolte A**, Prognostic factors for preoperative consultation of women desiring sterilization: findings of a retrospective analysis, *J Psychosom Obstet Gynaecol* 16:45, 1995.
715. **Hardy E, Bahamondes L, Osis MJ, Costa RG, Faundes A**, Risk factors for tubal sterilization regret, detectable before surgery, *Contraception* 54:159, 1996.
716. **Curtis KM, Mohllajee AP, Peterson HB**, Regret following female sterilization at a young age: a systematic review, *Contraception* 73:205, 2006.
717. **Opsahl MS, Klein TA**, The role of laparoscopy in the evaluation of candidates for sterilization reversal, *Fertil Steril* 48:546, 1987.
718. **Henderson SR**, The reversibility of female sterilization with the use of microsurgery: a report on 102 patients with more than one year of follow-up, *Am J Obstet Gynecol* 149:57, 1984.
719. **Rock JA, Chang YS, Limpaphayom K, Koetswang S, Moeloek FA, Guzick DS, Burkman RT, King TM**, Microsurgical tubal anastomosis: a controlled trial in four Asian centers, *Microsurgery* 5:95, 1984.
720. **Boeckx W, Gordts S, Buysse K, Brosens I**, Reversibility after female sterilization, *Br J Obstet Gynaecol* 93:839, 1986.
721. **te Velde ER, Boer ME, Looman CW, Habbema JD**, Factors influencing success or failure after reversal of sterilization: a multivariate approach, *Fertil Steril* 54:270, 1990.
722. **Winston RM**, Tubal surgery or in vitro fertilization (IVF)? *J Assist Reprod Genet* 9:309, 1992.
723. **Dubuisson JB, Chapron C, Nos C, Morice P, Aubriot FX, Garnier P**, Sterilization reversal: fertility results, *Hum Reprod* 10:1145, 1995.
724. **Rouzi AA, Mackinnon M, McComb PF**, Predictors of success of reversal of sterilization, *Fertil Steril* 64:29, 1995.
725. **Glock JL, Kim AH, Hulka JF, Hunt RB, Trad FS, Brumsted JR**, Reproductive outcome after tubal reversal in women 40 years of age or older, *Fertil Steril* 65:863, 1996.

726. **Penzias AS, DeCherney AH**, Is there ever a role for tubal surgery? *Am J Obstet Gynecol* 174:1218, 1996.
727. **Van Voorhis BJ**, Comparison of tubal ligation reversal procedures, *Clin Obstet Gynecol* 43:641, 2000.
728. **Yoon TK, Sung HR, Kang HG, Cha SH, Lee CN, Cha KY**, Laparoscopic tubal anastomosis: fertility outcome in 202 cases, *Fertil Steril* 72:1121, 1999.
729. **Falcone T, Goldberg JM, Margossian H, Stevens L**, Robotic-assisted laparoscopic microsurgical tubal anastomosis: a human pilot study, *Fertil Steril* 73:1040, 2000.
730. **Cha SH, Lee MH, Kim JH, Lee CN, Yoon TK, Cha KY**, Fertility outcome after tubal anastomosis by laparoscopy and laparotomy, *J Am Assoc Gynecol Laparosc* 8:348, 2001.
731. **Rodgers AK, Goldberg JM, Hammel JP, Falcone T**, Tubal anastomosis by robotic compared with outpatient minilaparotomy, *Obstet Gynecol* 109:1375, 2007.
732. **Dharia Patel SP, Steinkampf MP, Whitten SJ, Malizia BA**, Robotic tubal anastomosis: surgical technique and cost effectiveness, *Fertil Steril* 90:1175, 2008.
733. **Boer-Meisel ME, te Velde ER, Habbema JD, Kardaun JW**, Predicting the pregnancy outcome in patients treated for hydrosalpinx: a prospective study, *Fertil Steril* 45:23, 1986.
734. **Canis M, Mage G, Pouly JL, Manhes H, Wattiez A, Bruhat MA**, Laparoscopic distal tuboplasty: report of 87 cases and a 4-year experience, *Fertil Steril* 56:616, 1991.
735. **Diamond E**, Lysis of postoperative pelvic adhesions in infertility, *Fertil Steril* 31:287, 1979.
736. **Gomel V**, Salpingo-ovariolysis by laparoscopy in infertility, *Fertil Steril* 40:607, 1983.
737. **Donnez J, Casanas-Roux F**, Prognostic factors of fimbrial microsurgery, *Fertil Steril* 46:200, 1986.
738. **Dubuisson JB, Bouquet de Joliniere J, Aubriot FX, Darai E, Foulot H, Mandelbrot L**, Terminal tuboplasties by laparoscopy: 65 consecutive cases, *Fertil Steril* 54:401, 1990.
739. **Dlugi AM, Reddy S, Saleh WA, Mersol-Barg MS, Jacobsen G**, Pregnancy rates after operative endoscopic treatment of total (neosalpingostomy) or near total (salpingostomy) distal tubal occlusion, *Fertil Steril* 62:913, 1994.
740. **Taylor RC, Berkowitz J, McComb PF**, Role of laparoscopic salpingostomy in the treatment of hydrosalpinx, *Fertil Steril* 75:594, 2001.
741. **Kitchin JD III, Nunley WC Jr, Bateman BG**, Surgical management of distal tubal occlusion, *Am J Obstet Gynecol* 155:524, 1986.
742. **Daniell JF, Diamond MP, McLaughlin DS, Martin DC, Feste J, Surrey MW, Friedman S, Vaughn WK**, Clinical results of terminal salpingostomy with the use of the CO2 laser: report of the Intraabdominal Laser Study Group, *Fertil Steril* 45:175, 1986.
743. **Audebert AJ, Pouly JL, Von Theobald P**, Laparoscopic fimbrioplasty: an evaluation of 35 cases, *Hum Reprod* 13:1496, 1998.
744. **Marana R, Quagliarello J**, Distal tubal occlusion: microsurgery versus in vitro fertilization—a review, *Int J Fertil* 33:107, 1988.
745. **Zeyneloglu HB, Arici A, Olive D**, Adverse effects of hydrosalpinx on pregnancy rates after in vitro fertilization—embryo transfer, *Fertil Steril* 70:492, 1998.
746. **Camus E, Poncelet C, Goffinet F, Wainer B, Meriet F, Nisand I, et al.**, Pregnancy rates after in-vitro fertilization in cases of tubal infertility with and without hydrosalpinx: a meta-analysis of published comparative studies, *Hum Reprod* 14:1243, 1999.
747. **Beyler SA, James KP, Fritz MA, Meyer WR**, Hydrosalpingeal fluid inhibits in-vitro embryonic development in a murine model, *Hum Reprod* 12:2724, 1997.
748. **Meyer WR, Castelbaum AJ, Somkuti S, Sagoskin AW, Doyle M, Harris JE, Lessey BA**, Hydrosalpinges adversely affect markers of endometrial receptivity, *Hum Reprod* 12:1393, 1997.
749. **Strandell A, Lindhard A, Waldenstrom U, Thorburn J**, Hydrosalpinx and IVF outcome: cumulative results after salpingectomy in a randomized controlled trial, *Hum Reprod* 16:2403, 2001.
750. **Johnson N, van Voorst S, Sowter MC, Strandell A, Mol BW**, Surgical treatment for tubal disease in women due to undergo in vitro fertilisation, *Cochrane Database Syst Rev* (1):CD002125, 2010.
751. **Sagoskin AW, Lessey BA, Mottla GL, Richter KS, Chetkowski RJ, Chang AS, et al.**, Salpingectomy or proximal tubal occlusion of unilateral hydrosalpinx increases the potential for spontaneous pregnancy, *Hum*

Reprod 18:2634, 2003.

752. **Aboulghar MA, Mansour RT, Serour GI**, Spontaneous intrauterine pregnancy following salpingectomy for a unilateral hydrosalpinx, *Hum Reprod* 17:1099, 2002.
753. **Choe J, Check JH**, Salpingectomy for unilateral hydrosalpinx may improve in vivo fecundity, *Gynecol Obstet Invest* 48:285, 1999.
754. **Kotlyar A, Gingold J, Shue S, Falcone T**, The effect of salpingectomy on ovarian function, *J Minim Invasive Gynecol* 24:563, 2017.
755. **Mohamed AA, Yosef AH, James C, Al-Hussaini TK, Bedaiwy MA, Amer SAKS**, Ovarian reserve after salpingectomy: a systematic review and meta-analysis, *Acta Obstet Gynecol Scand* 96:795, 2017.
756. **Zhang Y, Sun Y, Guo Y, Li TC, Duan H**, Salpingectomy and proximal tubal occlusion for hydrosalpinx prior to in vitro fertilization: a meta-analysis of randomized controlled trials, *Obstet Gynecol Surv* 70:33, 2015.
757. **Van Voorhis BJ, Sparks AE, Syrop CH, Stovall DW**, Ultrasound-guided aspiration of hydrosalpinges is associated with improved pregnancy and implantation rates after in-vitro fertilization cycles, *Hum Reprod* 13:736, 1998.
758. **Tsiami A, Chaimani A, Mavridis D, Siskou M, Assimakopoulos E, Sotiriadis A**, Surgical treatment for hydrosalpinx prior to in-vitro fertilization embryo transfer: a network meta-analysis, *Ultrasound Obstet Gynecol* 48:434, 2016.
759. **Bloechle M, Schreiner T, Lisse K**, Recurrence of hydrosalpinges after transvaginal aspiration of tubal fluid in an IVF cycle with development of a serometra, *Hum Reprod* 12:703, 1997.
760. **Xu B, Zhang Q, Zhao J, Wang Y, Xu D, Li Y**, Pregnancy outcome of in vitro fertilization after Essure and laparoscopic management of hydrosalpinx: a systematic review and meta-analysis, *Fertil Steril* 108:84, 2017.
761. **Barbosa MW, Sotiriadis A, Papatheodorou SI, Mijatovic V, Nastri CO, Martins WP**, High miscarriage rate in women treated with Essure® for hydrosalpinx before embryo transfer: a systematic review and meta-analysis, *Ultrasound Obstet Gynecol* 48:556, 2016.
762. **Al-Jaroudi D, Herba MJ, Tulandi T**, Reproductive performance after selective tubal catheterization, *J Minim Invasive Gynecol* 12:150, 2005.
763. **Fortier KJ, Haney AF**, The pathologic spectrum of uterotubal junction obstruction, *Obstet Gynecol* 65:93, 1985.
764. **De Silva PM, Chu JJ, Gallos ID, Vidyasagar AT, Robinson L, Coomarasamy A**, Fallopian tube catheterization in the treatment of proximal tubal obstruction: a systematic review and meta-analysis, *Hum Reprod* 32:836, 2017.
765. **Farhi J, Ben-Haroush A, Lande Y, Fisch B**, Role of treatment with ovarian stimulation and intrauterine insemination in women with unilateral tubal occlusion diagnosed by hysterosalpingography, *Fertil Steril* 88:396, 2007.
766. **Patton PE, Williams TJ, Coulam CB**, Microsurgical reconstruction of the proximal oviduct, *Fertil Steril* 47:35, 1987.
767. **Patton PE, Williams TJ, Coulam CB**, Results of microsurgical reconstruction in patients with combined proximal and distal tubal occlusion: double obstruction, *Fertil Steril* 48:670, 1987.
768. **Marana R, Quagliarello J**, Proximal tubal occlusion: microsurgery versus IVF—a review, *Int J Fertil* 33:338, 1988.
769. **Gleicher N, Confino E, Corfman R, Coulam C, DeCherney A, Haas G, Katz E, Robinson E, Turk-Kaspa I, Vermesh M**, The multicentre transcervical balloon tuboplasty study: conclusions and comparison to alternative technologies, *Hum Reprod* 8:1264, 1993.
770. **Wiedemann R, Hepp H**, Selection of patients for IVF therapy or alternative therapy methods, *Hum Reprod* 4:23, 1989.
771. **Dodson WC, Whitesides DB, Hughes CL Jr, Easley HA III, Haney AF**, Superovulation with intrauterine insemination in the treatment of infertility: a possible alternative to gamete intrafallopian transfer and in vitro fertilization, *Fertil Steril* 48:441, 1987.
772. **Crosignani PG, Collins J, Cooke ID, Diczfalusy E, Rubin B**, Recommendations of the ESHRE workshop on ‘Unexplained Infertility’. Anacapri, August 28–9, 1992, *Hum Reprod* 8:977, 1993.

773. **Crosignani PG, Collins J, Cooke ID, Diczfaluzi E, Rubin B**, Unexplained infertility, *Hum Reprod* 8:977, 1993.
774. **Somigliana E, Paffoni A, Busnelli A, Filippi F, Pagliardini L, Vignani P, Vercellini P**, Age-related infertility and unexplained infertility: an intricate clinical dilemma, *Hum Reprod* 31:1390, 2016.
775. **ESHRE Capri Workshop Group**, A prognosis-based approach to infertility: understanding the role of time *Hum Reprod* 32:1556, 2017.
776. **Conner SJ, Lefevre L, Hughes DC, Barratt CL**, Cracking the egg: increased complexity in the zona pellucida, *Hum Reprod* 20:1148, 2005.
777. **Chatzimeletiou K, Morrison EE, Prapas N, Prapas Y, Handyside AH**, The centrosome and early embryogenesis: clinical insights, *Reprod Biomed Online* 16:485, 2008.
778. **Moomjy M, Sills ES, Rosenwaks Z, Palermo GD**, Implications of complete fertilization failure after intracytoplasmic sperm injection for subsequent fertilization and reproductive outcome, *Hum Reprod* 13:2212, 1998.
779. **Liu J, Nagy Z, Joris H, Tournaye H, Smits J, Camus M, Devroey P, Van Steirteghem A**, Analysis of 76 total fertilization failure cycles out of 2732 intracytoplasmic sperm injection cycles, *Hum Reprod* 10:2630, 1995.
780. **Gurgan T, Urman B, Yarali H, Kisinisci HA**, The results of in vitro fertilization-embryo transfer in couples with unexplained infertility failing to conceive with superovulation and intrauterine insemination, *Fertil Steril* 64:93, 1995.
781. **Ruiz A, Remohi J, Minguez Y, Guanes PP, Simon C, Pellicer A**, The role of in vitro fertilization and intracytoplasmic sperm injection in couples with unexplained infertility after failed intrauterine insemination, *Fertil Steril* 68: 171, 1997.
782. **Takeuchi S, Minoura H, Shibahara T, Shen X, Futamura N, Toyoda N**, In vitro fertilization and intracytoplasmic sperm injection for couples with unexplained infertility after failed direct intraperitoneal insemination, *J Assist Reprod Genet* 17:515, 2000.
783. **Martin JS, Nisker JA, Parker JI, Kaplan B, Tummon IS, Yuzpe AA**, The pregnancy rates of cohorts of idiopathic infertility couples gives insights into the underlying mechanism of infertility, *Fertil Steril* 64:98, 1995.
784. **Boklage CE**, Survival probability of human conceptions from fertilization to term, *Int J Fertil* 35:75, 1990.
785. **Macklon NS, Geraedts JP, Fauser BC**, Conception to ongoing pregnancy: the 'black box' of early pregnancy loss, *Hum Reprod Update* 8:333, 2002.
786. **Staessen C, Platteau P, Van Assche E, Michiels A, Tournaye H, Camus M, Devroey P, Liebaers I, Van Steirteghem A**, Comparison of blastocyst transfer with or without preimplantation genetic diagnosis for aneuploidy screening in couples with advanced maternal age: a prospective randomized controlled trial, *Hum Reprod* 19:2849, 2004.
787. **Mastenbroek S, Twisk M, van Echten-Arends J, Sikkema-Raddatz B, Korevaar JC, Verhoeve HR, Vogel NE, Arts EG, de Vries JW, Bossuyt PM, Buys CH, Heineman MJ, Repping S, van der Veen F**, In vitro fertilization with preimplantation genetic screening, *N Engl J Med* 357:9, 2007.
788. **Mardon H, Grewal S, Mills K**, Experimental models for investigating implantation of the human embryo, *Semin Reprod Med* 25:410, 2007.
789. **Fazolebas AT**, Physiology and pathology of implantation in the human and nonhuman primate, *Semin Reprod Med* 25:405, 2007.
790. **Tapia A, Gangi LM, Zegers-Hochschild F, Balmaceda J, Pommer R, Trejo L, Pacheco IM, Salvatierra AM, Henriquez S, Quezada M, Vargas M, Rios M, Munroe DJ, Croxatto HB, Velasquez L**, Differences in the endometrial transcript profile during the receptive period between women who were refractory to implantation and those who achieved pregnancy, *Hum Reprod* 23:340, 2008.
791. **Collins JA, Van Steirteghem A**, Overall prognosis with current treatment of infertility, *Hum Reprod Update* 10:309, 2004.
792. **Lenton EA, Weston GA, Cooke ID**, Long-term follow-up of the apparently normal couple with a complaint of infertility, *Fertil Steril* 28:913, 1977.
793. **Hunault CC, Habbema JD, Eijkemans MJ, Collins JA, Evers JL, te Velde ER**, Two new prediction rules for spontaneous pregnancy leading to live birth among subfertile couples, based on the synthesis of three

previous models, *Hum Reprod* 19:2019, 2004.

794. **Guzick DS, Sullivan MW, Adamson GD, Cedars MI, Falk RJ, Peterson EP, Steinkampf MP**, Efficacy of treatment for unexplained infertility, *Fertil Steril* 70:207, 1998.
795. **Collins J, Rowe T**, Age of the female partner is a prognostic factor in prolonged unexplained infertility: a multicenter study, *Fertil Steril* 52:15, 1989.
796. **Zikopoulos K, West CP, Thong PW, Kalser EM, Morrison J, Wu FCW**, Homologous intra-uterine insemination has no advantage over timed natural intercourse when used in combination with ovulation induction for the treatment of unexplained infertility, *Hum Reprod* 8:563, 1993.
797. **Martinez AR, Bernardus RE, Voorhorst FJ, Vermeiden JP, Schoemaker J**, Intrauterine insemination does and clomiphene citrate does not improve fecundity in couples with infertility due to male or idiopathic factors: a prospective, randomized, controlled study, *Fertil Steril* 53:847, 1990.
798. **Verhulst SM, Cohlen BJ, Hughes E, Te Velde E, Heineman MJ**, Intra-uterine insemination for unexplained subfertility, *Cochrane Database Syst Rev* (2):CD001838, 2006.
799. **Bhattacharya S, Harrild K, Mollison J, Wordsworth S, Tay C, Harrold A, McQueen D, Lyall H, Johnston L, Burrage J, Grossett S, Walton H, Lynch J, Johnstone A, Kini S, Raja A, Templeton A**, Clomifene citrate or unstimulated intrauterine insemination compared with expectant management for unexplained infertility: pragmatic randomised controlled trial, *Br Med J* 337:a716, 2008.
800. **Steures P, van der Steeg JW, Hompes PG, Bossuyt PM, Habbema JD, Eijkemans MJ, Schols WA, Burggraaff JM, van der Veen F, Mol BW**, Effectiveness of intrauterine insemination in subfertile couples with an isolated cervical factor: a randomized clinical trial, *Fertil Steril* 88:1692, 2007.
801. **Randall JM, Templeton A**, The effects of clomiphene citrate upon ovulation and endocrinology when administered to patients with unexplained infertility, *Hum Reprod* 6:659, 1991.
802. **Glazener CMA, Coulson C, Lambert PA, Watt EM, Hinton RA, Kelly NG, Hull MGR**, Clomiphene treatment for women with unexplained infertility: placebo-controlled study of hormonal responses and conception rates, *Gynecol Endocrinol* 4:75, 1990.
803. **Harrison RF, O'Moore RR**, The use of clomiphene citrate with and without human chorionic gonadotropin, *Ir Med J* 76:273, 1983.
804. **Fujii S, Fukui A, Fukushi Y, Kagiya A, Sato S, Saito Y**, The effects of clomiphene citrate on normal ovulatory women, *Fertil Steril* 68:997, 1997.
805. **Fisch P, Casper RF, Brown SE, Wrixon W, Collins JA, Reid RL, Simpson C**, Unexplained infertility: evaluation of treatment with clomiphene citrate and human chorionic gonadotropin, *Fertil Steril* 51:828, 1989.
806. **Deaton JL, Gibson N, Blackmer KM, Nakajima ST, Badger GJ, Brumsted JR**, A randomized, controlled trial of clomiphene citrate and intrauterine insemination in couples with unexplained infertility, *Fertil Steril* 54:1083, 1990.
807. **Farquhar CM, Liu E, Armstrong S, Arroll N, Lensen S, Brown J**, Intrauterine insemination with ovarian stimulation versus expectant management for unexplained infertility (TUI): a pragmatic, open-label, randomised, controlled, two-centre trial, *Lancet* 391:441, 2018.
808. **Arici A, Byrd W, Bradshaw K, Kutteh WH, Marshburn P, Carr BR**, Evaluation of clomiphene citrate and human chorionic gonadotropin treatment: a prospective, randomized, crossover study during intrauterine insemination cycles, *Fertil Steril* 61:314, 1994.
809. **Karlstrom P-O, Bergh T, Lundkvist O**, A prospective randomized trial of artificial insemination versus intercourse in cycles stimulated with human menopausal gonadotropin or clomiphene citrate, *Fertil Steril* 59:554, 1993.
810. **Agarwal S, Mittal S**, A randomised prospective trial of intrauterine insemination versus timed intercourse in superovulated cycles with clomiphene, *Indian J Med Res* 120:519, 2004.
811. **Reindollar RH, Regan MM, Neumann PJ, Levine BS, Thornton KL, Alper MM, Goldman MB**, A randomized clinical trial to evaluate optimal treatment for unexplained infertility; the fast track and standard treatment (FASTT) trial, *Fertil Steril* 94:888, 2010.
812. **Custers IM, Steures P, Hompes P, Flierman P, van Kasteren Y, van Dop PA, van der Veen F, Mol BW**, Intrauterine insemination: how many cycles should we perform? *Hum Reprod* 23:885, 2008.

813. **Dovey S, Sneeringer RM, Penzias AS**, Clomiphene citrate and intrauterine insemination: analysis of more than 4100 cycles, *Fertil Steril* 90:2281, 2008.
814. **Guzick DS, Carson SA, Coutifaris C, Overstreet JW, Factor-Litvak P, Steinkampf MP, Hill JA, Mastroianni L Jr, Buster JE, Nakajimi ST, Vogel DL, Canfield RE**; for the **National Cooperative Reproductive Medicine Network**, Efficacy of superovulation and intrauterine insemination in the treatment of infertility, *N Engl J Med* 340:177, 1999.
815. **Gregoriou O, Vitoratos N, Papadias C, Konidaris S, Gargaropoulos A, Louridas C**, Controlled ovarian hyperstimulation with or without intrauterine insemination for the treatment of unexplained infertility, *Int J Gynaecol Obstet* 48:55, 1995.
816. **Steures P, van der Steeg JW, Hompes PG, Habbema JD, Eijkemans MJ, Broekmans FJ, Verhoeve HR, Bossuyt PM, van der Veen F, Mol BW**, Intrauterine insemination with controlled ovarian hyperstimulation versus expectant management for couples with unexplained subfertility and an intermediate prognosis: a randomised clinical trial, *Lancet* 368:216, 2006.
817. **Diamond MP, Legro RS, Coutifaris C, Alvero R, Robinson RD, Casson P, Christman GM, Ager J, Huang H, Hansen KR, Baker V, Usadi R, Seungdamrong A, Bates GW, Rosen RM, Haisenleder D, Krawetz SA, Barnhart K, Trussell JC, Ohl D, Jin Y, Santoro N, Eisenberg E, Zhang H**; **NICHD Reproductive Medicine Network**, Letrozole, gonadotropin, or clomiphene for unexplained infertility, *New Engl J Med* 373:1230, 2015.
818. **Peeraer K, Debrock S, De Loecker P, Tomassetti C, Laenen A, Welkenhuysen M, Meeuwis L, Pelckmans S, Mol BW, Spiessens C, De Neubourg D, D'Hooghe TM**, Low-dose human menopausal gonadotrophin versus clomiphene citrate in subfertile couples treated with intrauterine insemination: a randomized controlled trial, *Hum Reprod* 30(5):1079, 2015.
819. **Cantineau AE, Cohlen BJ, Heineman MJ**, Ovarian stimulation protocols (anti-oestrogens, gonadotrophins with and without GnRH agonists/antagonists) for intrauterine insemination (IUI) in women with subfertility, *Cochrane Database Syst Rev* (2):CD005356, 2007.
820. **Luo S, Li S, Jin S, Li Y, Zhang Y**, Effectiveness of GnRH antagonist in the management of subfertile couples undergoing controlled ovarian stimulation and intrauterine insemination: a meta-analysis, *PLoS One* 9:e109133, 2014.
821. **Crosignani PG, Walters DE, Soliani A**, The ESHRE multicentre trial on the treatment of unexplained infertility: a preliminary report. *European Society of Human Reproduction and Embryology*, *Hum Reprod* 6:953, 1991.
822. **Goverde AJ, McDonnell J, Vermeiden JP, Schats R, Rutten FF, Schoemaker J**, Intrauterine insemination or in-vitro fertilisation in idiopathic subfertility and male subfertility: a randomised trial and cost-effectiveness analysis, *Lancet* 355:13, 2000.
823. **Custers IM, König TE, Broekmans FJ, Hompes PG, Kaaijk E, Oosterhuis J, Mochtar MH, Repping S, van Wely M, Steures P, van der Veen F, Mol BW**, Couples with unexplained subfertility and unfavorable prognosis: a randomized pilot trial comparing the effectiveness of in vitro fertilization with elective single embryo transfer versus intrauterine insemination with controlled ovarian stimulation, *Fertil Steril* 96:1107, 2011.
824. **Bensdorp AJ, Tjon-Kon-Fat RI, Bossuyt PM, Koks CA, Oosterhuis GJ, Hoek A, Hompes PG, Broekmans FJ, Verhoeve HR, de Bruin JP, van Golde R, Repping S, Cohlen BJ, Lambers MD, van Bommel PF, Slappendel E, Perquin D, Smeenk JM, Pelinck MJ, Gianotten J, Hoozemans DA, Maas JW, Eijkemans MJ, van der Veen F, Mol BW, van Wely M**, Prevention of multiple pregnancies in couples with unexplained or mild male subfertility: randomised controlled trial of in vitro fertilisation with single embryo transfer or in vitro fertilisation in modified natural cycle compared with intrauterine insemination with controlled ovarian hyperstimulation, *BMJ* 350:g7771, 2015.
825. **Nandi A, Bhide P, Hooper R, Gudi A, Shah A, Khan K, Homburg R**, Intrauterine insemination with gonadotropin stimulation or in vitro fertilization for the treatment of unexplained subfertility: a randomized controlled trial, *Fertil Steril* 107:1329, 2017.
826. **Tjon-Kon-Fat RI, Tajik P, Zafarmand MH, Bensdorp AJ, Bossuyt PMM, Oosterhuis GJE, van Golde R, Repping S, Lambers MDA, Slappendel E, Perquin D, Pelinck MJ, Gianotten J, Maas JWM**,

- Eijkemans MJC, van der Veen F, Mol BW, van Wely M; INeS study group**, IVF or IUI as first-line treatment in unexplained subfertility: the conundrum of treatment selection markers, *Hum Reprod* 32:1028, 2017.
827. **van Peperstraten AM, Nelen WL, Hermens RP, Jansen L, Scheenjes E, Braat DD, Grol RP, Kremer JA**, Why don't we perform elective single embryo transfer? A qualitative study among IVF patients and professionals, *Hum Reprod* 23:2036, 2008.
828. **Elit L, Charles C, Dimitry S, Tedford-Gold S, Gafni A, Gold I, Whelan T**, It's a choice to move forward: women's perceptions about treatment decision making in recurrent ovarian cancer, *Psychooncology* 19:318, 2010.
829. **Vahratian A**, Utilization of fertility-related services in the United States, *Fertil Steril* 90:1317, 2008.
830. **Elgindy EA, El-Haieg DO, El-Sebaey A**, Anti-Mullerian hormone: correlation of early follicular, ovulatory and midluteal levels with ovarian response and cycle outcome in intracytoplasmic sperm injection patients, *Fertil Steril* 89:1670, 2008.
831. **Maia H Jr, Pimentel K, Silva TM, Freitas LA, Zausner B, Athayde C, Coutinho EM**, Aromatase and cyclooxygenase-2 expression in endometrial polyps during the menstrual cycle, *Gynecol Endocrinol* 22:219, 2006.
832. **Papaioannou S, Afnan M, Girling AJ, Coomarasamy A, Ola B, Olufowobi O, McHugo JM, Hammadih N, Sharif K**, The effect on pregnancy rates of tubal perfusion pressure reductions achieved by guide-wire tubal catheterization, *Hum Reprod* 17:2174, 2002.
833. **Athallah N, Proctor M, Johnson NP**, Oral versus injectable ovulation induction agents for unexplained subfertility, *Cochrane Database Syst Rev* (3):CD003052, 2002.
834. **Bureau of Labor Statistics, News Release**. Employment Characteristics of Families—2016, Released April 20, 2017.
835. **Marshall LM, Spiegelman D, Barbieri RL, Goldman MB, Manson JE, Colditz GA, Willett WC, Hunter DJ**, Variation in the incidence of uterine leiomyoma among premenopausal women by age and race, *Obstet Gynecol* 90(6):967, 1997.
836. **Ferraretti AP, La Marca A, Fauser BCJM, Tarlatzis B, Nargund G, Gianaroli L**, ESHRE consensus on the definition of 'poor response' to ovarian stimulation for in vitro fertilization: the Bologna criteria, *Hum Reprod* 26:1616, 2011.
837. **Humaidan P, Alviggi C, Fischer R, Esteves SC**, The novel POSEIDON stratification of low prognosis patients in assisted reproductive technology and its proposed marker of successful outcome, *F100 Research* 5:2911, 2016.
838. **Zinaman M, Johnson S, Ellis J, Ledger W**, Accuracy of perception of ovulation day in women trying to conceive, *Curr Med Res Opin* 28(5):749, 2012.
839. **Hua Y, Zhang W, Hu X, Yang A, Zhu X**, The use of misoprostol for cervical priming prior to hysteroscopy: a systematic review and analysis, *Drug Des Devel Ther* 10:2789, 2016.
840. **Yanaihara A, Yorimitsu T, Motoyama H, Iwasaki S, Kawamura T**, Location of endometrial polyp and pregnancy rate in infertility patients, *Fertil Steril* 90:180, 2008.
841. **Zagoria RJ, Regan SW, Dyer RB**, Nonsurgical fallopian tube recanalization for treatment of infertility, *N C Med J* 52:491, 1991.

# Male Infertility

Our understanding of male reproductive function and the importance of male factors in infertility has advanced significantly over the last two decades. In the past, the female partner was the primary focus of attention and male factors were regarded as a relatively uncommon cause of infertility. We now recognize that abnormalities in the male are the sole cause of infertility in approximately 20% of infertile couples and are an important contributing factor in another 20–40% of couples with reproductive failure.<sup>1</sup>

Correct diagnosis and specific treatment can help many infertile men to achieve a natural conception with their partners. In others, mild but important semen abnormalities can be overcome by treatments such as intrauterine insemination (IUI). When all else is futile or fails, modern assisted reproductive technologies (ART) still may provide the means to achieve success. In vitro fertilization (IVF) by intracytoplasmic sperm injection (ICSI), involving the injection of a single sperm directly into a mature oocyte, offers men previously considered hopelessly infertile a realistic chance to father children. Artificial insemination using donor sperms, once the only option available for many couples with male factor infertility, remains an important and highly effective treatment strategy but now may be regarded as the treatment of last resort.

Physicians who care for infertile couples must know how to conduct a basic evaluation of male reproductive function and how to recognize men who require more extensive or sophisticated evaluation and treatment beyond the scope of their own expertise. This chapter will consider the regulation of testicular function, describe the causes of male infertility, discuss the analysis of semen and other methods for evaluation of infertile men, and review current concepts regarding the treatment of male factor infertility.



# REGULATION OF TESTICULAR FUNCTION

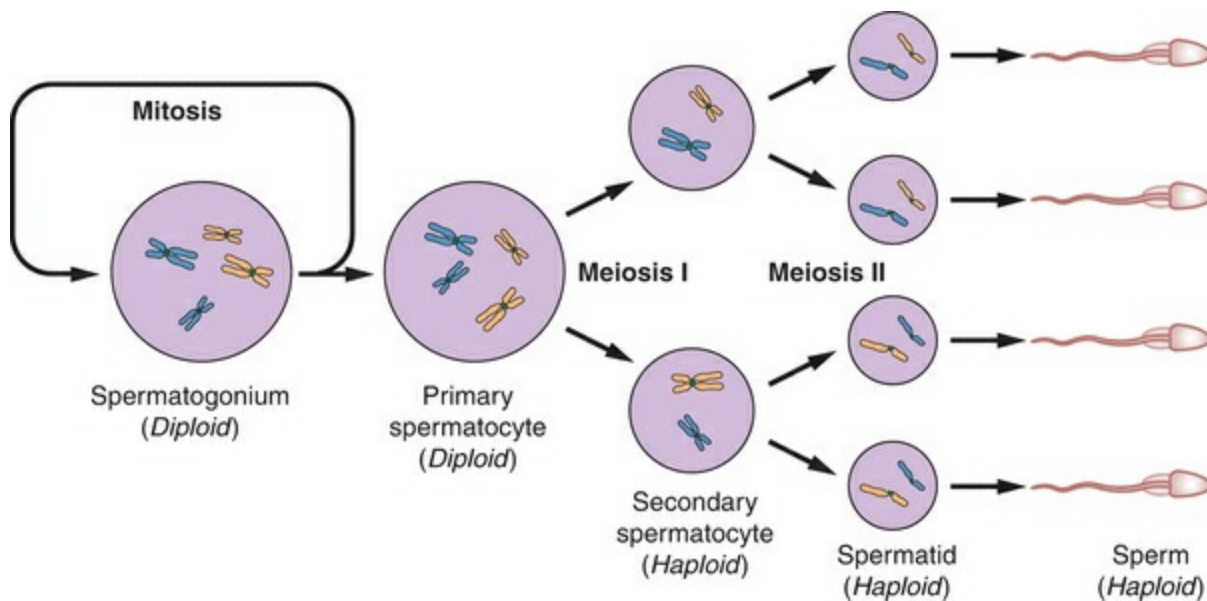
---

The testes have two distinct components, the seminiferous tubules (the site of spermatogenesis) and the Leydig cells (the source of testosterone). The seminiferous tubules are composed of germ cells, called spermatogonia, and Sertoli cells, which produce inhibin. Tight junctions between the Sertoli cells form a diffusion barrier known as the blood-testis barrier (similar to the blood-brain barrier), which protects the germ cells from antigens, antibodies, and environmental toxins.<sup>2</sup> The seminiferous tubules are therefore essentially avascular, so regulatory molecules must enter by diffusion. The Leydig cells are located in the connective tissue between the seminiferous tubules.

# Spermatogenesis

After migration of the germ cells to the genital ridge during embryogenesis, there are approximately 300,000 spermatogonia in each gonad. Each undergoes a series of mitotic divisions, and by puberty, there are about 600 million in each testis. Continued proliferation during adult life supports the production of approximately 100–200 million sperms each day and more than 1 trillion during a normal reproductive lifespan.<sup>3</sup> A spermatogonia-specific transcription factor identified in mice, Plzf, is required for maintenance of the spermatogonial stem cell pool.<sup>4,5</sup>

As spermatogenesis begins, the diploid (46 chromosomes) spermatogonia grow to become primary spermatocytes before entering meiosis. The first meiotic division yields 2 haploid (23 chromosomes, each made up of 2 chromatids joined at the centromere) secondary spermatocytes, each of which gives rise to 2 spermatids (23 chromosomes, each consisting of a single chromatid) during the second meiotic division. Thereafter, each spermatid gradually matures to become a mature spermatozoon. Approximately 3 million spermatogonia begin development each day, but about half of all potential sperm production is lost during meiosis (**Figure 26.1**).<sup>6</sup>



**FIGURE 26.1**

As spermatids develop into mature sperms, the nucleus moves to an eccentric position at the head of the spermatid and becomes covered by an acrosomal cap.<sup>7</sup> The core of the sperm tail consists of nine outer fibers around two inner fibers, surrounded in the middle section by mitochondria. The tail fibers are attached to each other by arms

containing the protein dynein, which is an ATPase. Hydrolysis of ATP (adenosine triphosphate) in the adjacent mitochondria provides the energy for sperm motility, which is accomplished by a sliding action between the fibers in the sperm tail.

**The spermatogenic process is directed by genes located on the Y chromosome<sup>8</sup> and takes approximately 70 days to complete from the spermatocyte stage.<sup>9</sup> Another 12–21 days are required for the transport of sperms from the testis through the epididymis to the ejaculatory duct.<sup>10</sup> During passage through the epididymis, sperms mature further to develop the capacity for sustained motility.<sup>11</sup> The long time required for sperm development and transit implies that the results of a semen analysis reflect conditions existing many weeks earlier.** Final maturation, or capacitation, of sperms may occur after ejaculation into the female genital tract. Normal spermatogenesis requires the lower temperature of the scrotum, but slight increases in scrotal temperature, such as those associated with the wearing of athletic supporters, do not appear to have any measureable adverse effect.<sup>12</sup> Semen includes secretions contributed by the prostate, the seminal vesicles, and the distal vasa deferentia.

# Hormone Regulation

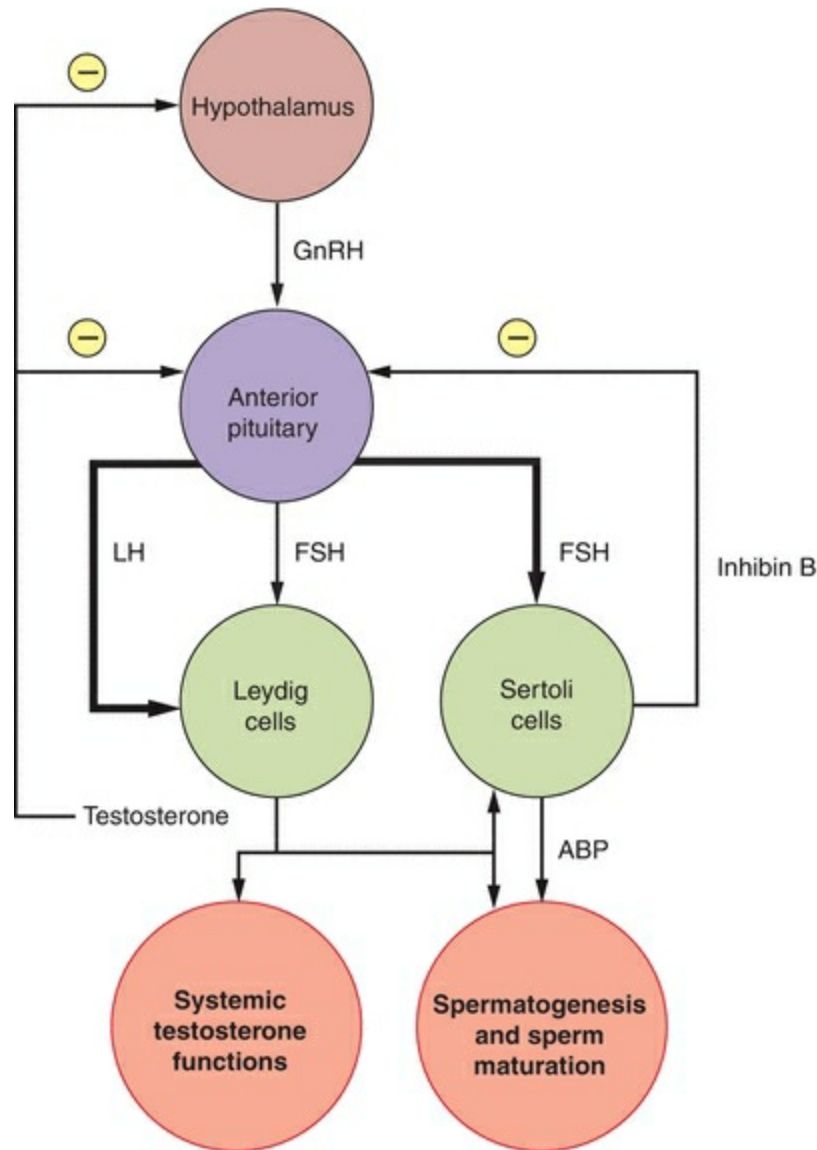
Normal testicular function requires the actions of both pituitary gonadotropins, follicle-stimulating hormone (FSH) and luteinizing hormone (LH). LH stimulates the Leydig cells in the testicular interstitium to synthesize and secrete testosterone (approximately 5–10 mg/day). The actions of LH are supported indirectly by FSH, which induces the appearance of LH receptors on testicular Leydig cells<sup>13</sup> and stimulates synthesis of androgen-binding protein (ABP) in Sertoli cells.<sup>14</sup> Testosterone is secreted both into the circulation and into the lumen of the seminiferous tubules where it is highly concentrated to the levels needed to support spermatogenesis in the germinal epithelium and sperm maturation in the epididymis; concentrations within the testes are 50–100 times higher than in blood.<sup>15,16</sup> The actions of testosterone in support of spermatogenesis are mediated by the Sertoli cells, which line the seminiferous tubules and contain androgen receptors.<sup>16</sup>

Rising serum testosterone levels exert feedback inhibition on LH secretion, acting both at the hypothalamic level to slow the pulsatile release of hypothalamic gonadotropin-releasing hormone (GnRH),<sup>17,18</sup> probably via a mechanism involving endogenous opiates,<sup>19</sup> and at the pituitary level to decrease pituitary gonadotrope sensitivity to GnRH stimulation.<sup>20</sup> Numerous studies involving infusions of testosterone, estradiol, or dihydrotestosterone (which cannot be converted to estrogen) or the administration of estrogen antagonists in normal subjects,<sup>21,22</sup> in individuals with androgen insensitivity,<sup>23</sup> and in men with idiopathic hypogonadotropic hypogonadism<sup>24</sup> have established that testosterone exerts its negative feedback effects on LH secretion both directly and indirectly via conversion to estradiol in the brain. Evidence that estradiol is involved in LH feedback control derives from the observation that LH levels are elevated in men with aromatase deficiency<sup>25</sup> and after treatment with aromatase inhibitors.<sup>26</sup>

In contrast to its effects on LH secretion, physiologic levels of testosterone do not suppress FSH secretion. Rather, the regulation of pituitary FSH (but not LH) secretion is controlled by inhibin. FSH levels rise progressively after orchiectomy, the observation that led ultimately to the discovery of inhibin. Inhibin B is synthesized and secreted by Sertoli cells in response to FSH stimulation and specifically inhibits GnRH-stimulated pituitary FSH secretion.<sup>27,28,29</sup> In the castrated male monkey, treatment with recombinant human inhibin can restore normal FSH levels in the absence of testosterone.<sup>30</sup> Sertoli cell inhibin B secretion is modulated indirectly by LH via testosterone, which inhibits Sertoli cell inhibin B gene expression.<sup>31</sup> Inhibin A is not produced in any significant amount in men. Evidence from studies in vitro suggests that other autocrine/paracrine

regulatory mechanisms involving locally produced growth factors, neuropeptides, vasoactive peptides, and immune-derived cytokines also are involved, much like the complex interactions that operate in the ovarian follicle.<sup>32,33,34,35,36</sup> The Sertoli cells of the testis are analogous to the granulosa cells of the ovary, and the Leydig cells are comparable to the theca cells.

The extent to which FSH and LH are needed to initiate and maintain spermatogenesis has been difficult to define because observations in various natural and experimentally induced conditions have yielded conflicting evidence. The presence of sperms in the ejaculate of a man with an inactivating mutation in the LH  $\beta$ -subunit gene and in other men with isolated LH deficiency suggests that FSH alone can initiate spermatogenesis,<sup>37</sup> although the possibility of some residual LH activity or FSH-stimulated Leydig cell testosterone production via Sertoli cell factors cannot be excluded.<sup>38</sup> Conversely, low-level sperm production in men with inactivating mutations of the FSH receptor<sup>39</sup> and other forms of isolated FSH deficiency<sup>40,41</sup> suggest that LH-driven testosterone production alone can initiate spermatogenesis, although the possibility of residual FSH activity in the presence of high circulating FSH concentrations must be acknowledged. Evidence that high doses of exogenous testosterone can stimulate complete spermatogenesis in immature monkeys, albeit at low levels, further suggests that FSH is not an absolute requirement,<sup>42</sup> but descriptions of azoospermic men with mutations in the FSH  $\beta$ -subunit gene suggest the opposite.<sup>43,44</sup> In men with hypogonadotropic hypogonadism of prepubertal onset, normal spermatogenesis can be stimulated by combined treatment with human chorionic gonadotropins (hCG, having potent LH-like actions) and human menopausal gonadotropin (containing FSH), but not by treatment with hCG alone<sup>45</sup> (**Figure 26.2**).

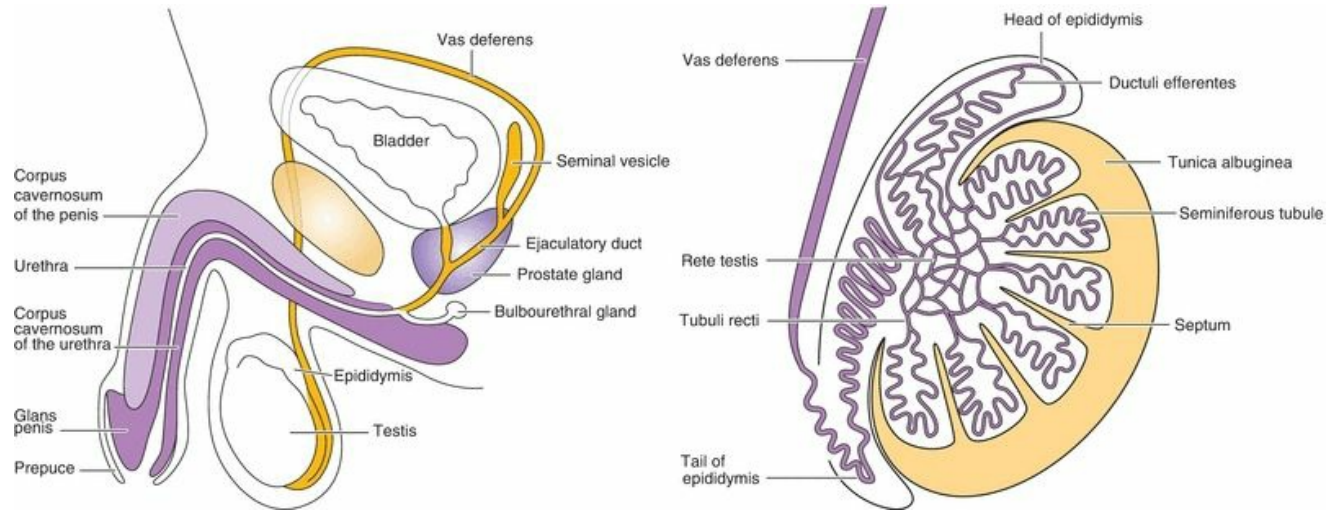


**FIGURE 26.2**

The requirements for the maintenance of spermatogenesis are similarly controversial. The observation in monkeys that exogenous FSH can maintain testicular volume and the numbers of spermatogonia after complete suppression of gonadotropin secretion by treatment with a GnRH antagonist suggests that FSH alone can maintain spermatogenesis in primates, at least to some degree.<sup>46,47</sup> The description of a unique individual with an activating mutation of the FSH receptor (function in the absence of FSH stimulation) and normal inhibin B levels (a marker for FSH-stimulated Sertoli cell function)<sup>48</sup> who had undergone hypophysectomy for removal of a benign pituitary tumor (eliminating all endogenous gonadotropin secretion) and remained fertile while receiving only physiologic exogenous testosterone replacement therapy (normally inadequate to support spermatogenesis in hypophysectomized men) serves to further illustrate the

importance of FSH in maintaining spermatogenesis.<sup>49</sup> In contrast, the restoration of fertility after treatment with only exogenous hCG in azoospermic men with isolated gonadotropin deficiency (low levels of both FSH and LH) suggests that although LH-stimulated testosterone production may be insufficient to initiate spermatogenesis, it is sufficient to maintain spermatogenesis.<sup>50</sup> In men who develop hypogonadotropic hypogonadism after puberty, during adulthood (e.g., due to a pituitary tumor), spermatogenesis stops but usually can be restored by treatment with hCG alone.<sup>45</sup>

**Regardless whether FSH- or LH-stimulated testosterone alone is sufficient to initiate or to maintain spermatogenesis, both clearly are required for qualitatively and quantitatively normal sperm production.** The importance of FSH has been demonstrated in a variety of experiments in nonhuman primates and men involving the selective suppression of FSH by immunization against FSH or by high-dose chronic exogenous hCG treatment. FSH suppression induces both qualitative and quantitative abnormalities of semen quality that can be reversed by simultaneous treatment with exogenous FSH but not with testosterone.<sup>51,52,53,54,55</sup> Moreover, in male contraceptive trials involving treatment with high doses of testosterone, alone or in combination with levonorgestrel to suppress spermatogenesis, azoospermia developed only in men whose serum FSH concentration was suppressed to undetectable levels.<sup>56,57</sup> The importance of testosterone in spermatogenesis is evident from observations that FSH alone can induce proliferation of the seminiferous epithelium in prepubertal monkeys, but only treatment with both FSH and hCG increases testicular volume and the numbers of Sertoli cells and spermatogonia.<sup>58,59</sup> Also, in men with idiopathic hypogonadotropic hypogonadism (due to absent GnRH stimulation), exogenous pulsatile GnRH stimulation or a combination of exogenous FSH and LH or hCG can induce spermatogenesis and achieve fertility,<sup>60,61,62</sup> but treatment with FSH, alone or in combination with low doses of testosterone (insufficient to achieve the high local concentrations of testosterone required to support spermatogenesis) (**Figure 26.3**).<sup>63</sup>



**FIGURE 26.3**



# AGING AND MALE REPRODUCTIVE FUNCTION

---

Although aging has adverse effects on male reproductive function, the impact of age is less obvious than it is in women. Semen quality and male fertility, as well as androgen production and serum testosterone levels, decrease very gradually as age increases.

# Aging and Male Fertility

The relationship between age and fertility in men is more difficult to define than in women, largely due to the fundamental difference in gametogenesis between the two sexes. In women, the number of oocytes present at birth inexorably declines as age advances until it is functionally exhausted at menopause, and fertility declines with the number of oocytes remaining (Chapter 25). In men, mitotic divisions in the spermatogonia throughout life replenish the supply of germ cells, and spermatogenesis continues well into advanced ages, allowing men to reproduce even during senescence. Although fertility in men does appear to decline as age increases, the effects of age are much less distinct. The issue may be growing in importance because an increasing number of men are choosing to father children at older ages. In the United States, birth rates for men between the ages of 35 and 54 increased by nearly 30% between 1980 (68.2 per 1,000 men) and 2000 (88.3 per 1,000 men).<sup>64,65</sup>

**Semen volume, sperm motility, and the proportion of morphologically normal sperm, but not sperm concentration, appear to decrease gradually as age increases.**<sup>66,67</sup> However, semen characteristics generally do not accurately predict fertilizing capacity<sup>68,69,70,71</sup>; neither do endocrine parameters.<sup>72,73</sup> A study in a convenience cohort of nearly 100 men aged 22–80 with no known fertility factors observed decreases in semen volume (−0.03 mL/year), total motility (−0.7% per year), progressive motility (−3.1% per year), and total (progressively) motile sperm count (−4.7% per year).<sup>67</sup> Another study that examined the relationship between age and semen quality among over 400 male partners of women pursuing pregnancy via IVF using donor oocytes found that total motile sperm count decreased by approximately 2.5 million sperms per year.<sup>74</sup>

**On balance, the available evidence indicates that pregnancy rates decrease and time to conception increases as male age increases.**<sup>66,75</sup> In studies of the effect of male partner age on pregnancy rates, female partner age and declining coital frequency with increasing age are obvious and important confounding factors.<sup>76</sup> A study of the risk of infertility associated with paternal age, involving over 6,000 randomly selected European women aged 25–44, observed that the risk of infertility was increased two- to threefold among women aged 35–39 when the male partner was 40 years or older.<sup>77</sup> Others have observed that pregnancy rates for men over 50 are 23–38% lower than for men under age 30<sup>66</sup> and that the probability of achieving pregnancy within a year is approximately 50% lower for men over age 35 than for those under age 25.<sup>78</sup> Results of a British study (adjusted for partner age and coital frequency) indicate that time to conception is fivefold longer for men over age 45 than for men under age 25, even when analysis is restricted to men with young partners.<sup>75</sup> Two other studies have suggested

that male fertility may start to decline before age 40.<sup>79,80</sup>

A study examining the effect of paternal age on pregnancy and live birth rates in couples undergoing ART found that pregnancy rates declined with each additional year of age of the male partner.<sup>81</sup> Another study of IVF outcomes involving almost 2,000 women with tubal factor infertility (absent or obstructed fallopian tubes) determined that advanced paternal age (40 years and greater) increased the risk for treatment failure approximately twofold for women aged 35–40 years and more than fivefold for women aged 41 and older.<sup>82</sup> Within the context of assisted reproduction, the effect of paternal age is perhaps best assessed in couples using oocyte donation, which makes male age the dependent variable (because almost all oocyte donors are aged 18–35). However, data from such studies are conflicting, with some indicating that male age has limited or no impact on pregnancy, implantation, and live birth rates<sup>74,83,84</sup> and others finding that paternal age is inversely related to reproductive outcomes,<sup>85,86</sup> including a decrease in live birth rates and an increase in miscarriage rates.

There are several possible biologic mechanisms that might contribute to an age-related decline in male fertility. One involves cellular or physiologic changes in the male reproductive tract. The testes and prostate exhibit morphologic changes with aging that might adversely affect both sperm production and the biochemical properties of semen.<sup>87</sup> Autopsy studies of men who died from accidental causes have observed narrowing and sclerosis of the seminiferous tubules, decreased spermatogenic activity, and reduced numbers of germ cells and Leydig cells as age increases.<sup>88,89</sup> Another possible mechanism is age-related changes in the hypothalamic-pituitary-testicular axis. Average FSH levels in men increase after age 30,<sup>90</sup> suggesting that the endocrine environment may begin to change during midlife.<sup>91</sup> Decreased semen volume may relate to reduced androgen-stimulated fluid production in the prostate and seminal vesicles because testosterone levels decrease with advancing age.<sup>92</sup> Whatever the mechanism(s), decreasing fertility with increasing male age in healthy couples suggests that normal sperm overproduction may not fully buffer the effects of increasing age. **However, because there is little or no overall measurable decline in male fertility before age 45–50, the available data suggest that male factors likely contribute relatively little to the overall age-related decline in fertility in women.**

## Paternal Age and Pregnancy Outcomes

Because male germ cells pass through more mitotic replications than those of females, there is greater opportunity for error. Older men also are more likely than younger men to have smoked (and for longer periods of time) and to have been exposed to gonadotoxins that may cause DNA damage.<sup>66,67</sup> **Increased paternal age has been**

associated with an increase in numerical and structural chromosomal abnormalities,<sup>93,94,95,96,97</sup> with increased DNA fragmentation,<sup>98</sup> and with a higher frequency of point mutations.<sup>99</sup> There also is evidence to suggest that increasing male age may raise the risk of spontaneous abortion in young women.<sup>85,86,100</sup>

A number of studies have observed that advanced paternal age is associated with an increase in the prevalence of **birth defects** (e.g., neural tube defects, cardiac defects, and limb defects) and **congenital diseases** (e.g., Wilms tumor).<sup>101,102,103,104,105</sup> In a large population-based retrospective cohort study that included over 5 million births, the observed overall prevalence of birth defects was 1.5%; compared with infants born to fathers aged 25–29 years, the adjusted odds ratios for birth defects were 1.04 for infants with fathers aged 30–35 years, 1.08 for those with fathers aged 40–45 years and 45–50 years, and 1.15 for those with fathers over 50 years old.<sup>106</sup> These data suggest that the risk for birth defects increases only slightly, if at all, with increasing paternal age.

Advanced paternal age has been associated with an increase in new **autosomal dominant mutations** (e.g., achondroplasia and Alpert, Waardenburg, Crouzon, Pfeiffer, and Marfan syndromes).<sup>107</sup> At least in theory, this observation might reflect a decrease in the activity of antioxidant enzymes in the semen and sperms of older men, increasing their susceptibility to mutation.<sup>108</sup> DNA repair mechanisms also may be impaired in older men. Although the relative risk of autosomal dominant disorders is increased markedly, the absolute risk is still very small (<1%) because autosomal dominant diseases are rare.<sup>109</sup>

Evidence indicates that advanced paternal age is associated with an increased risk for **schizophrenia** in offspring<sup>110,111,112</sup>; overall, the incidence is increased two- to threefold for children whose fathers are over age 45 years, possibly as a consequence of mutations emerging during spermatogenesis.<sup>113</sup> Similarly, increasing paternal age has been associated with an increased risk for **autism** in children, which may reflect de novo mutations or errors in genetic imprinting.<sup>114,115,116,117,118</sup>

In older fathers, mutations resulting in **X-linked disease** also may be more common; examples include hemophilia A and Duchenne muscular dystrophy.<sup>119</sup> The “grandfather effect” describes their transmission from carrier daughters to affected grandsons. Overall, **advanced paternal age does not appear to be associated with any significant increase in the risk of fetal autosomal or sex chromosome aneuploidy.**<sup>119,120,121,122,123,124</sup> However, available data are limited and confounded by female partner age. Moreover, results from one study examining the chromosomal complement of paternal gametes suggest that the incidence of sex chromosome aneuploidy may increase with age.<sup>124</sup> A population-based study involving more than 4

million children observed that paternal age was associated with a small but significant increase in risk of leukemia and central nervous system cancers.<sup>125</sup>

It still is not clear whether the risk for miscarriage increases with paternal age, because results of studies conducted thus far are conflicting, with some finding evidence for an association with both early and late fetal loss<sup>100,126,127</sup> and others not.<sup>128,129</sup> Whereas one retrospective study of 558 pregnancies conceived using donor oocytes observed no association between paternal age and live birth rate,<sup>74</sup> another found that risk for miscarriage increased with paternal age.<sup>83</sup> **On balance, the weight of available evidence suggests that advanced paternal age may be associated with a small increase in the risk of spontaneous abortion.** Limited data suggest that advanced paternal age does not significantly increase the risk for fetal growth restriction<sup>130,131</sup> or stillbirth.<sup>132</sup>

# Androgen Deficiency in the Aging Male

**Serum total and free testosterone levels decrease in men as age increases.**<sup>133</sup> However, unlike the profound estrogen deficiency and associated symptoms that occur after menopause in women, the age-related decline in androgen levels in men is more gradual and smaller,<sup>134</sup> and the clinical consequences of decreasing androgen levels are not yet clear.

Serum testosterone concentrations exhibit a distinct diurnal variation in young men (with highest levels in the morning) but vary relatively little in elderly men.<sup>135</sup> In the cross-sectional European Male Ageing Study, involving 3,220 men aged 40–79 years, serum total testosterone concentrations fell by an average of 0.4% per year and free testosterone levels by 1.3% per year.<sup>136</sup> Longitudinal studies have observed a somewhat greater age-related decline in testosterone concentrations and found that levels decrease at a fairly constant rate.<sup>133,137,138</sup> Because sex hormone-binding globulin (SHBG) concentrations increase gradually with age, free testosterone levels decrease more than do total testosterone concentrations.<sup>134</sup> In the Massachusetts Male Aging Study, free testosterone levels fell by an average of almost 3% per year.<sup>139</sup> SHBG levels also may rise in association with increased abdominal obesity, further contributing to the decrease in free testosterone.<sup>140</sup>

As testosterone levels fall steadily, an increasing percentage of aging men become hypogonadal, as defined by testosterone concentrations (total testosterone <300–325 ng/dL, free testosterone <5 ng/dL) and/or by signs and symptoms of hypogonadism. In one population-based observational survey, the prevalence of hypogonadism ranged from 3% to 7% among men aged 30–69 years and was 18% in men over age 70.<sup>141</sup> In a longitudinal study, serum total testosterone levels in the hypogonadal range were observed in 20% of men in their 60s, in 30% of those in their 70s, and in 50% of men in their 80s.<sup>133</sup>

In some men over age 50, decreasing serum androgen concentrations may be associated with clinical symptoms and signs of androgen deficiency suggesting “andropause.” Symptoms of androgen deficiency may include decreased libido,<sup>142,143</sup> with or without erectile dysfunction<sup>144</sup>; reduced strength, energy, or stamina<sup>145</sup>; irritability and perceptions of a lower quality of life<sup>146</sup>; sleep disturbance, depressed mood, and lethargy<sup>141</sup>; and changes in cognitive function.<sup>147,148</sup> Symptoms may be accompanied by physical changes, including osteopenia or osteoporosis,<sup>149</sup> decreased muscle mass,<sup>150</sup> increased visceral adipose tissue,<sup>151</sup> testicular atrophy, and gynecomastia. Epidemiologic studies have observed that low serum testosterone concentrations are associated with the development of central obesity, increased insulin

levels, the metabolic syndrome, diabetes, and increased mortality.<sup>152,153,154,155</sup> Validated questionnaires now are available for use in evaluating older men.<sup>156,157</sup> However, scores do not predict or correlate well with measured free and total testosterone levels<sup>158</sup> and therefore lack specificity for the diagnosis of androgen deficiency in the aging male (ADAM).<sup>159,160,161</sup>

**Men with symptoms or signs of androgen deficiency merit evaluation by measuring the serum total testosterone level, ideally during the morning hours to minimize the influence of pulsatile and circadian rhythms in testosterone secretion. Frankly low concentrations (<200 ng/dL) should be confirmed by repeated measurements.**<sup>162</sup> Serum total testosterone includes not only free testosterone but also testosterone bound to albumin and SHBG. “Bioavailable testosterone” is the sum of free and albumin-bound testosterone and the measurement that has correlated best with bone mineral density<sup>145</sup> and sexual<sup>163</sup> and cognitive function<sup>148</sup> in epidemiologic studies. Because the serum total testosterone level occasionally may be misleading, some prefer to measure free or bioavailable testosterone, but the accuracy of free testosterone assays has been challenged<sup>164</sup> and neither assay is widely available. A free testosterone index (FTI) calculated from measurements of total testosterone and SHBG (total testosterone/SHBG) provides an indirect measure of the amount of bioavailable testosterone. **It is important to emphasize that in men with documented androgen deficiency, a normal or low serum LH suggests a secondary hypogonadism that merits additional evaluation by measurement of serum prolactin and magnetic resonance imaging (MRI) to detect any hypothalamic or pituitary mass lesion.**

## Treatment

**A consensus of expert opinion published in 2002 suggested that a total testosterone level under 200 ng/dL (6.9 nmol/L) is evidence of hypogonadism that warrants treatment in symptomatic men, that those with concentrations between 200 and 400 ng/dL (6.9–13.9 nmol/L) may benefit from treatment, and that higher levels all but exclude androgen deficiency.**<sup>165</sup> A bioavailable testosterone level below the normal range for normal young adult men or an FTI less than 0.153 (nmol/nmol) also is consistent with the diagnosis of androgen deficiency.<sup>133</sup> **Evidence-based guidelines issued by the Endocrine Society in 2006 recommended that, in the absence of pituitary or testicular disease, testosterone therapy be reserved for men with clearly and consistently low serum total testosterone concentrations (<200 ng/dL) and clinically important symptoms of androgen deficiency.**<sup>162</sup>

The potential risks of testosterone treatment include fluid retention, gynecomastia, increased red blood cell mass, worsening of sleep apnea, promotion of benign or

subclinical malignant prostate disease, and possible added risk for cardiovascular disease.<sup>166</sup> **Accordingly, the Endocrine Society guidelines recommend against testosterone treatment in men with prostate or breast cancer, a palpable prostate nodule or induration, prostate-specific antigen (PSA) greater than 3 ng/mL without further urologic evaluation, erythrocytosis (hematocrit >50%), untreated obstructive sleep apnea, severe lower urinary tract symptoms (International Prostate Symptom Score >19), or class III or IV heart failure.**<sup>162</sup>

Any of the commercial formulations of testosterone may be used for treatment. Androgen therapy may involve parenteral testosterone esters (75 mg/week or 150 mg every 2 weeks), implanted pellets (225 mg every 4–6 months), scrotal (40 cm<sup>2</sup>, one patch daily) or peripheral skin patches (5 mg, one patch daily), or testosterone gel (5 g/day); treatment should be individualized. At present, there are no data to indicate that any one formulation is clearly superior. **The therapeutic goal is to raise serum testosterone concentrations over pretreatment values without exceeding the normal range for young adult men. The target serum testosterone concentration should be lower than that for younger men (e.g., 300–400 ng/dL) to decrease the potential risk of testosterone-dependent disease.**<sup>162</sup> Dehydroepiandrosterone may be converted to testosterone and is commercially available as an oral dietary health supplement; standard doses (50–100 mg daily) generally do not raise serum testosterone concentrations, although higher doses may.<sup>167</sup>

In randomized, placebo-controlled studies, the effects of testosterone therapy on bone density have been inconsistent. In one, no overall increase in hip or spine bone density was observed, but treatment had the greatest effect in men with the lowest pretreatment testosterone levels.<sup>168</sup> In another, testosterone treatment did not increase bone density but prevented the decrease observed in men receiving placebo.<sup>169</sup> In a third, testosterone treatment (with and without finasteride, which blocks conversion of testosterone to dihydrotestosterone) increased spine bone density by 9–10% and hip bone density by 2–3%.<sup>170</sup> All three studies<sup>168,169,171</sup> and a subsequent systematic review<sup>162</sup> found that testosterone treatment increased fat free mass and decreased fat mass. However, the increase in lean mass did not result in any consistent improvement in muscle strength or physical performance.<sup>168,169,171</sup> Testosterone treatment also was not accompanied by any demonstrable improvement in quality of life measures or sexual function, as judged by questionnaires.<sup>168,169</sup>

**Androgen therapy must be monitored because the long-term health risks and benefits of treatment have not been established.** A baseline physical examination (breasts, heart, lungs, prostate), serum PSA, and complete blood count should be obtained; prostate biopsy is recommended when the digital rectal examination or serum



PSA is abnormal. Within 3 months after therapy begins, men receiving androgen therapy should be evaluated for weight gain and any signs of emerging peripheral edema, gynecomastia or breast tenderness, sleep disorders, or prostate enlargement. Recommended monitoring also includes hemoglobin or hematocrit and a serum PSA. A rapid rise in PSA (>1 ng/mL) soon after treatment begins suggests the possibility of an undetected prostate cancer and is reason to discontinue treatment pending a thorough prostate evaluation.<sup>172</sup> Serum testosterone also should be measured to ensure that treatment is achieving the target concentration, but the subjective clinical response is the most important gauge of the effectiveness of androgen therapy. Men with a good clinical response, no apparent adverse effects, and normal testosterone levels may continue treatment but should return for similar monitoring after another 6 months and at least annually thereafter. If osteoporosis was one of the indications for treatment, bone mineral density also should be reevaluated approximately 1–2 years after treatment starts.

In clinical trials of testosterone treatment in elderly men, only a few cases of prostate cancer have been observed, but statistical power was insufficient to support a conclusion that testosterone treatment does not increase risk for prostate cancer. A meta-analysis including 19 trials found that testosterone treatment was associated with a higher prevalence of elevated PSA values and prostate cancer, although biopsy was more commonly performed in men receiving treatment.<sup>173</sup> There is little evidence that short-term treatment has adverse effects on the prostate,<sup>174</sup> but the effects of long-term treatment remain uncertain. Similarly, it is not clear whether physiologic testosterone therapy increases the risk of sleep apnea, because data are conflicting.<sup>173,175,176,177</sup> However, testosterone treatment in elderly men clearly can cause erythrocytosis. In individual studies, up to one-third of treated men have developed an abnormally elevated hematocrit,<sup>170,178</sup> and a meta-analysis concluded that testosterone treatment is associated with more than a fourfold increased risk for erythrocytosis.<sup>173</sup> Taken together, evidence indicates that testosterone treatment in hypogonadal men has little effect on serum concentrations of total and low-density lipoprotein cholesterol.<sup>179</sup>

# CAUSES OF MALE INFERTILITY

---

Male infertility may result from a variety of causes. Some, like ductal obstruction and hypogonadotropic hypogonadism, can be defined accurately and treated effectively. Others, like primary testicular failure, can be defined but are not amenable to treatment, and still others, like seminiferous tubule dysfunction, cannot be corrected but can be overcome by IUI or ART. Although rare, male infertility also may be the first indication of a serious underlying medical condition. **Unfortunately, much of male infertility is idiopathic, reflecting our still very poor understanding of the mechanisms that govern testicular function.**

The list of known causes of male infertility is long and varied but can be divided into four major categories: (1) hypothalamic-pituitary disorders (1–2%), which may be congenital, be acquired, or result from systemic illness; (2) primary gonadal disorders (30–40%), both congenital and acquired; (3) disorders of sperm transport (10–20%); and (4) idiopathic (40–50%). (See [Table 26.1](#) for additional details.)

## TABLE 26.1 Causes of Male Infertility

### Hypothalamic-pituitary disorders

- Idiopathic isolated gonadotropin deficiency
- Kallmann syndrome
- Single gene mutations (e.g., involving the GnRH receptor, FSH $\beta$ , LH $\beta$ , or transcription factors involved in pituitary development)
- Hypothalamic and pituitary tumors (e.g., craniopharyngioma, macroadenoma)
- Infiltrative diseases (sarcoidosis, histiocytosis, transfusion siderosis, hemochromatosis)
- Hyperprolactinemia
- Drugs (GnRH analogs, androgens, estrogens, glucocorticoids, opiates)
- Critical illness or injury
- Chronic systemic illness or malnutrition
- Infections (e.g., meningitis)
- Obesity

---

### Primary gonadal disorders

- Klinefelter syndrome
- Y chromosome deletions
- Single-gene mutations and polymorphisms (e.g., involving the androgen, estrogen, or FSH receptor)
- Cryptorchidism
- Varicoceles
- Infections (e.g., viral orchitis, leprosy, tuberculosis)
- Drugs (e.g., alkylating agents, alcohol, antiandrogens, cimetidine)
- Radiation
- Environmental gonadotoxins (e.g., heat, smoking, metals, organic solvents, pesticides)
- Chronic illness (renal insufficiency, cirrhosis, cancer, sickle cell disease, amyloidosis, vasculitis, celiac disease)

---

### Disorders of sperm transport

- Epididymal obstruction or dysfunction
  - Congenital bilateral absence of the vas deferens (relating to *CFTR* mutations)
  - Infections causing obstruction of the vas deferens (e.g., gonorrhea, *Chlamydia*, tuberculosis)
  - Vasectomy
  - Kartagener syndrome (primary ciliary dyskinesia)
  - Young syndrome
  - Ejaculatory dysfunction (e.g., spinal cord disease, autonomic dysfunction)
-

# Hypothalamic-Pituitary Disorders

**Any hypothalamic or pituitary disease or disorder causing a deficiency of GnRH or gonadotropins can cause male infertility.** The most common congenital cause is idiopathic isolated gonadotropin deficiency due to absent or defective GnRH secretion (resulting in sexual infantilism).<sup>180</sup> When accompanied by one or more extragonadal abnormalities, such as anosmia, red-green color blindness, midline facial defects (e.g., cleft palate), neurosensory hearing loss, synkinesis (mirror movements), or renal anomalies, the disorder is known as **Kallmann syndrome**.<sup>181,182,183</sup> A variety of mutations have been identified in affected men, involving genes encoding cell surface adhesion molecules or receptors, which are required for normal migration of GnRH neurons from the olfactory placode to the hypothalamus; examples include KAL1,<sup>184,185</sup> fibroblast growth factor 1 (also known as KAL2),<sup>186</sup> and prokineticin-2 (PROK2) and its receptor (PROKR-2).<sup>187</sup> Other genetic causes of hypogonadotropic hypogonadism include rare mutations affecting the GnRH receptor,<sup>188</sup> the  $\beta$ -subunit of FSH,<sup>43</sup> or LH<sup>37,189,190</sup> or transcription factors involved in pituitary development during embryogenesis, such as LHX3,<sup>191</sup> LHX4, HESX1,<sup>192</sup> and PROP-1.<sup>193</sup>

Hypogonadotropic hypogonadism also can result from hypothalamic disease or treatments that inhibit GnRH secretion, abnormalities of the pituitary stalk that interfere with GnRH delivery, and pituitary disease that prevents normal gonadotropin secretion. **Hypothalamic or pituitary tumors** can distort the pituitary stalk or compress and suppress pituitary gonadotropes.

**Infiltrative diseases** of the hypothalamus or pituitary (sarcoidosis, histiocytosis, transfusion siderosis, hemochromatosis) can inhibit GnRH or pituitary gonadotropin secretion.<sup>194,195</sup> **Hyperprolactinemia** from any cause<sup>196</sup> and **treatment with GnRH analogs** (e.g., for prostate cancer), **androgens** (e.g., anabolic steroids),<sup>197</sup> **glucocorticoids**,<sup>198</sup> or **opiates**<sup>199,200,201</sup> can suppress gonadotropin secretion. **Critical illness**<sup>202</sup> or **injury** (e.g., head trauma)<sup>203</sup> and **chronic systemic illness** (e.g., diabetes mellitus) or **malnutrition** also have been associated with hypogonadotropic hypogonadism. **Infections** (e.g., meningitis) are another rare but recognized cause of hypopituitarism.<sup>204</sup>

**Obesity** in men is associated with hypogonadotropic hypogonadism, involving several mechanisms.<sup>205</sup> Serum free testosterone concentrations are inversely related to body weight and body mass index, independent of changes in SHBG levels,<sup>206,207,208</sup> and estrogen concentrations are elevated due to increased aromatase activity in adipose tissue.<sup>209</sup> **Obstructive sleep apnea** is a separate but related additional factor, resulting

in hypoxia.

# Primary Gonadal Disorders

Primary gonadal failure (hypergonadotropic hypogonadism) is a major cause of azoospermia and oligospermia and can result from a variety of congenital or acquired disorders, including Klinefelter syndrome, Y chromosome deletions, single gene mutations, cryptorchidism, varicoceles, and other less common causes.

## Klinefelter Syndrome

Klinefelter syndrome is one of the most common causes of primary testicular failure, affecting approximately 1 in 1,000 males,<sup>210,211</sup> and is characterized by sex chromosome aneuploidy. Although an extra X chromosome (47,XXY) is the most common form, some men with Klinefelter syndrome have a greater or lesser number of X chromosomes (e.g., 48,XXXY, 46,XY/47,XXY)<sup>212</sup>; 46,XX males, resulting from translocation of the testis-determining gene (SRY) to an X chromosome, also have Klinefelter syndrome. The phenotype varies with the number of extra X chromosomes and possibly also with the number of trinucleotide CAG repeats on the androgen receptor gene (a polymorphism); as the length of the repeat sequence increases, receptor activity decreases. A longer CAG repeat sequence has been associated with taller stature, lower bone mineral density, gynecomastia, and decreased penile length.<sup>213,214</sup>

**Men with Klinefelter syndrome generally have small, firm testes, resulting from damage to both seminiferous tubules and Leydig cells. Serum concentrations of FSH and LH are elevated and testosterone levels are decreased to a varying extent. Affected men have severely reduced sperm counts and are undervirilized.**<sup>212,215</sup> Cryptorchidism is more common in men with Klinefelter syndrome and causes more severe testicular damage.<sup>216</sup>

The length of the arms and legs is increased in men with Klinefelter syndrome, due both to testosterone deficiency and to an independent abnormality of the long bones. Men with Klinefelter syndrome also exhibit a number of psychosocial abnormalities,<sup>217</sup> which have been described as a marked lack of insight, poor judgment, and an impaired ability to learn from adverse experience.<sup>218</sup> They also may have difficulty with complex speech and a decreased attention span.<sup>219</sup> Later in life, they have an increased risk for developing pulmonary diseases, breast cancer,<sup>220</sup> mediastinal germ cell tumors,<sup>221</sup> varicose veins and leg ulcers,<sup>222</sup> systemic lupus erythematosus,<sup>223</sup> and diabetes mellitus.<sup>224</sup>

Other chromosomal abnormalities associated with primary gonadal failure include the 46,XY/45,X karyotype, causing a syndrome characterized by short stature and other

features of Turner syndrome.<sup>225</sup> Because the testes may be streak, dysgenetic, or normal, the phenotype varies from female to normal male. In those with a streak and a dysgenetic testis (mixed gonadal dysgenesis), the risk of gonadoblastoma is increased (approximately 20%), and gonadectomy is therefore indicated.

## Y Chromosome Deletions

**Microdeletions of the long arm of the Y chromosome are now recognized as a relatively common cause of severe oligospermia and azoospermia, affecting 2–5% of men with severe oligospermia and 8% of men with azoospermia.**<sup>226,227</sup> Most map to the Yq11 region (named azoospermia factor, or AZF), which contains three regions, AZFa, AZFb, and AZFc. Deletions of the AZFa or AZFb regions typically result in azoospermia. Mutations in the AZFc region cause infertility of varying severity, ranging from oligospermia to azoospermia, and are the largest known recurrent deletions in humans.<sup>228,229</sup> The DDX3Y and USP9Y genes, both located in the AZFa region, have been implicated as having an important role in spermatogenesis; azoospermia is consistently observed when both are deleted.<sup>230,231</sup> Y chromosome deletions also have been identified in men with cryptorchidism, varicocele, and obstructions of the vas deferens.<sup>232,233</sup>

**Because all Y chromosome abnormalities will be transmitted to sons of affected men conceived via ICSI, genetic testing and counseling should be offered to affected men before their sperms are used for that purpose.** Given the importance and potential consequences of Y chromosome deletions, there is a need to standardize the tests for their detection.<sup>234</sup>

## Single Gene Mutations and Polymorphisms

Normal male sexual differentiation and spermatogenesis require both normal androgen production and normal androgen receptors ([Chapter 9](#)). The androgen receptor plays an important role in the differentiation of spermatids and their release from the seminiferous epithelium. Consequently, it is not surprising that defects in androgen synthesis or androgen sensitivity are associated with infertility.<sup>235,236</sup>

As discussed above, the number of trinucleotide CAG repeats in exon 1 of the androgen receptor gene is inversely correlated with its transcriptional activity.<sup>213,214</sup> In one study in normal fertile men, those with short repeat sequences had the highest sperm concentrations.<sup>237</sup> However, studies in men with idiopathic infertility have yielded inconsistent results, with some finding an association between longer CAG repeat segments and male infertility<sup>238,239,240</sup> and others not.<sup>241</sup> **A meta-analysis including 33**

**studies concluded that men with idiopathic infertility had significantly longer CAG repeat lengths than did fertile men, suggesting that even subtle abnormalities in androgen action may adversely affect male fertility.**<sup>242</sup>

Evidence suggests that **disorders of estrogen synthesis or action** also may be associated with infertility in men. Impaired spermatogenesis has been observed in mice and in men lacking a functional estrogen receptor (alpha)<sup>243,244</sup> and in mice with an inactivating mutation in the aromatase enzyme.<sup>245</sup> Polymorphisms involving variations in the number of TA tandem repeats in the promoter region of the estrogen receptor gene also have been related to sperm production, with higher numbers of TA repeats being associated with lower sperm counts.<sup>246</sup> Inactivating mutations in the FSH receptor gene are a rare cause of male infertility.<sup>39,247</sup>

Several other autosomal and X-linked genes have been identified as important regulators of spermatogenesis. Men with myotonic dystrophy (an autosomal disorder associated with impaired motor function, cataracts, premature balding, mild mental retardation, and hypogonadism) also can exhibit abnormal spermatogenesis.<sup>248</sup> Mutations in the SYCP3 gene (involved in regulation of the synapse between homologous chromosomes during meiosis) have been implicated as a potential cause of male infertility.<sup>246</sup> Others include polymorphisms of DAZL (an autosomal homolog of the DAZ, deleted in azoospermia, gene),<sup>249,250,251,252,253</sup> PRM1 and PRM2 (protamines involved in chromatin compaction), TNP1 and TMP2 (transition nuclear proteins), and USP26 (deubiquitinating enzyme family).<sup>246</sup>

## **Cryptorchidism**

**Cryptorchidism results from a failure of testicular descent during fetal development, which is an androgen-dependent process.** Consequently, it is common in men with abnormalities of testosterone production, such as Kallmann syndrome, androgen resistance, and defects in testosterone synthesis. Cryptorchidism can be unilateral or bilateral and, in either case, is associated with impaired spermatogenesis and an increased risk for developing testicular tumors. Even in the absence of cryptorchidism, the incidence of testicular cancer is increased in infertile men.<sup>254,255</sup>

In men with cryptorchidism, serum FSH levels often are elevated, but LH concentrations generally are normal, reflecting normal Leydig cell function. **The severity of the semen abnormality relates to the duration of time the testes have been outside of the scrotum.** Because the testes are more easily retractable early in life, very young boys may appear transiently to have cryptorchidism, but in most, the testes descend and remain in the scrotum by age one.<sup>256</sup> Men having low serum inhibin



B levels, increased FSH concentrations, and decreased sperm density after repair of cryptorchidism are at increased risk for infertility.<sup>257</sup>

## Varicoceles

Varicoceles result from dilation of the pampiniform plexus of the spermatic veins in the scrotum. They are more prevalent in infertile men (up to 30%) than in fertile men (10–15%) and are 10 times more commonly found on the left than on the right, probably because the left spermatic vein is longer and joins the left renal vein at a right angle.<sup>258</sup>

**Although increased testicular temperature, delayed removal of local toxins, hypoxia, and stasis are viewed as the mechanisms likely responsible for the association between varicoceles and infertility, no causal relationship has been established.**<sup>259,260,261</sup>

## Other Causes of Primary Gonadal Failure

Certain **infections** are associated with male infertility. Mumps orchitis is widely recognized as a cause of male infertility. Although rare in prepubertal males, it occurs in up to 25% of adult men with mumps, some of whom become infertile. The mechanism may involve damage to the germinal epithelium, ischemia, or immune dysfunction.<sup>262,263</sup> Gonorrhea and chlamydial infections also can cause orchitis. Other infections associated with male infertility include tuberculosis, which may cause epididymal obstruction, leprosy,<sup>264</sup> and human immunodeficiency virus (HIV).<sup>265,266</sup>

**Drugs** that can adversely affect spermatogenesis or Leydig cell function include alkylating agents (e.g., cyclophosphamide, chlorambucil), antiandrogens (e.g., flutamide, cyproterone, spironolactone), ketoconazole, cimetidine, and anabolic steroids.<sup>267</sup> Doses of **radiation** as low as 0.015 Gy (15 rad) can suppress spermatogenesis, and doses above 6 Gy generally cause permanent azoospermia and infertility.<sup>268</sup>

Environmental exposures that may act as **gonadotoxins** include heat, smoking, metals, organic solvents, and pesticides. A modest increase in scrotal temperature can adversely affect spermatogenesis, and a febrile illness can result in dramatic, if also transient, decreases in sperm density and motility. Hyperthermia also may explain the infertility associated with spinal cord injuries and chronic sauna or spa exposure.<sup>269</sup> In theory, environmental sources of heat, including tight-fitting underclothing, hot baths and spas, and occupations that require long hours of sitting (long-distance driving) might decrease fertility, but none has ever been substantiated in clinical studies.<sup>12</sup> Smoking or heavy use of marijuana, alcohol, or cocaine can decrease semen quality and testosterone

levels.<sup>270,271,272</sup>

**Chronic illness,**<sup>273</sup> such as chronic renal insufficiency,<sup>274</sup> cirrhosis, or malnutrition,<sup>275</sup> can result in primary gonadal failure. Infertility also is common in men with sickle cell disease, probably due to testicular ischemia.

# Disorders of Sperm Transport

Even when sperm production is normal, epididymal obstruction or dysfunction can result in infertility. The cause of infertility is clear in men with obstruction, but relatively little is known about epididymal function. Isolated asthenospermia is presumed to result from epididymal dysfunction, and intrauterine exposure to diethylstilbestrol may be one cause.<sup>276</sup>

Congenital or acquired abnormalities of the vas deferens can cause obstruction and infertility. Approximately 1–2% of infertile men and up to 6% of men with obstructive azoospermia have **congenital bilateral absence of the vas deferens (CBAVD)**, almost always related to mutations in the cystic fibrosis transmembrane conductance regulator (CFTR) gene.<sup>277</sup> These men most commonly present with one of two genetic scenarios: a severe mutation in one allele and a mild mutation, which leaves some residual CFTR activity, in the other allele; or two mutant alleles with mild effect on the protein. Most affected men do not exhibit any respiratory and pancreatic disease. **Infections** (gonorrhea, Chlamydia, tuberculosis) and **vasectomy** are other causes of vasal obstruction. **Primary ciliary dyskinesia (Kartagener syndrome)** is a genetic disease that adversely affects cilia structure and function and generally presents as recurrent sinus and pulmonary infections, bronchiectasis, situs inversus, and male infertility due to oligoasthenospermia.<sup>278,279</sup> **Young syndrome** is another genetic disease, in which inspissated secretions in the vas and epididymis result in obstructive azoospermia.<sup>280,281</sup>

Ejaculatory dysfunction resulting from spinal cord disease or injury, sympathectomy, or autonomic disease is another cause of infertility relating to disorders of sperm transport.

# THE MALE INFERTILITY EVALUATION

---

The evaluation of the infertile male should be directed toward achieving all of the following goals<sup>282</sup>:

- To identify and to correct specific causes of infertility, when possible
- To identify individuals whose infertility cannot be corrected but may be overcome by IUI or use of various forms of ART
- To identify individuals having a genetic abnormality that may affect the health of any offspring that may be conceived through the use of ART
- To identify individuals whose infertility can neither be corrected nor overcome with ART, for whom adoption and the use of donor sperms are options worthy of consideration
- To identify any important underlying medical condition that may require specific medical attention

**Evaluation of the male partner should begin at the same time as in the female partner, generally when pregnancy fails to occur after 1 year of reasonably regular unprotected intercourse.** Earlier evaluation is indicated for men with any obvious infertility risk factor, those whose partner is age 35 or older (where it is important to identify all potential infertility factors as quickly and efficiently as possible), and men who have reason to question their fertility.

In the male partner, the most relevant parts of the medical history and physical examination include the following<sup>282</sup>:

## **History**

- Duration of infertility and previous fertility
- Coital frequency and any sexual dysfunction
- Results of any previous evaluation or treatment for infertility
- Childhood illnesses and developmental history
- Previous surgery, its indications and outcome, and systemic medical illnesses
- Past episodes of or exposures to sexually transmitted infections
- Exposures to environmental toxins, including heat
- Current medications and allergies
- Occupations and use of tobacco, alcohol, and other drugs

## **Physical Examination**

- Examination of the penis, to include the location of the urethral meatus

- Palpation of the testes and measurement of their size
- The presence and consistency of both the vasa and epididymides
- Presence of any varicocele
- Secondary sex characteristics, including body habitus, hair distribution, and breast development
- Digital rectal examination

A history of cryptorchidism or mumps orchitis suggests the possibility of testicular atrophy.<sup>262,283</sup> The timing and extent of secondary sexual development may alert one to the possibility of an endocrinopathy. Ductal obstruction can result from sexually transmitted infections. Diabetes mellitus (bladder neck dysfunction resulting in retrograde ejaculation) and cystic fibrosis (highly associated with congenital absence of the vas deferens) are medical illnesses that may hinder fertility in men. Inguinal hernia repair, renal transplant, and scrotal surgery are associated with risks for unrecognized injury to the vas deferens.<sup>284</sup> Retroperitoneal surgery may disrupt neural pathways and cause ejaculatory dysfunction; treatment with alpha-blockers, phentolamine, methyl dopa, guanethidine, or reserpine may have similar effects.

When the infertility evaluation is directed by the gynecologist or primary clinician, physical examination of the male may be deferred pending the results of the first semen analysis when there is no history of any male genital abnormality, trauma, surgery, or sexual dysfunction. However, an abnormal reproductive history or semen analysis is indication for additional formal evaluation that may be conducted by the gynecologist having the necessary training and experience but is most often performed by the urologist or other specialist in male reproduction.

# Semen Analysis

If a male infertility factor exists, it almost always will be revealed by an abnormal semen analysis, although other male factors (sexual dysfunction) may be involved even when semen quality is normal. **The initial evaluation for male factor infertility should include at least one properly performed semen analysis. If abnormal, another semen analysis should be obtained after at least 4 weeks.**<sup>282</sup> Semen parameters can vary widely over time, even among fertile men,<sup>285,286,287,288</sup> and also exhibit seasonal variations.<sup>289,290,291</sup> Considering that the overall objective is to gain a sense of the usual semen quality, over time, more than one analysis is helpful, because a single semen sample yields only a point estimate that may or may not be representative. However, with relatively few exceptions, a normal initial semen analysis generally excludes an important male factor when there is no complaint or suspicion of sexual dysfunction. Conversely, abnormal semen parameters suggest the need for additional endocrine, urologic, or genetic evaluation.

Standard but detailed instructions for semen collection should be provided, to include a defined abstinence period of 2–3 days. Shorter intervals of abstinence decrease the semen volume and sperm density but generally have little or no impact on sperm motility or morphology.<sup>292</sup> **Longer abstinence intervals increase semen volume and sperm density but also increase the proportion of dead, immotile, or morphologically abnormal sperm.**<sup>293</sup> Ideally, the semen specimen should be collected by masturbation directly into a clean container. If necessary, semen may be collected via intercourse using a specially manufactured Silastic condom that does not contain spermicidal agents like those in condoms intended for contraceptive purposes. Collection after withdrawal during intercourse risks loss of the initial portion of the specimen, which generally contains the highest concentration of sperms. If possible, the semen specimen should be collected in a private room within or near the laboratory. When necessary, the specimen can be collected at home but should be kept at room or body temperature during transport. Regardless of the method of collection, the semen sample should be examined within an hour after collection.

## Normal Reference Values

The normal reference values in wide use are based on comparisons of the values observed in the male partners of fertile and infertile couples without specific exclusion of female infertility factors<sup>294,295,296</sup> and therefore do not necessarily represent the average ranges observed in fertile men. Unfortunately, there is considerable overlap between the semen parameters observed in fertile and infertile men.<sup>297</sup> The normal reference ranges certainly do not represent the absolute minimum values needed for

conception; many men with values outside the normal ranges are fertile and many with normal values are nonetheless infertile.<sup>297,298,299,300</sup> **Values outside of normal ranges suggest a male infertility factor that may require additional clinical or laboratory evaluation, but each parameter must be considered in the context of the whole.** A mildly low sperm density may have little significance when semen volume, sperm motility, and the proportion of abnormal sperms are normal. Conversely, a normal sperm density offers little reassurance when semen volume is frankly low or the proportion of motile or normal sperms is grossly abnormal. **Overall, the odds of male infertility increase with the number of major semen parameters (concentration, motility, morphology) in the subfertile range; the probability is 2 to 3 times higher when one is abnormal, 5 to 7 times higher when two are abnormal, and 16 times greater when all three are abnormal.**<sup>297</sup>

Although detailed procedures for semen analysis have been established by the World Health Organization (WHO), the methods and accuracy of semen analyses as they are performed in physician offices, hospitals, and specialty andrology laboratories may vary. Ideally, to ensure accurate and reliable results, semen analyses should be performed in a laboratory having an established quality control program that conforms to the standards outlined in the Clinical Laboratory Improvement Amendments (CLIA; [www.hcfa.gov/medicaid/clia/clihome.htm](http://www.hcfa.gov/medicaid/clia/clihome.htm)).<sup>301,302</sup> The traditional WHO normal reference values are shown in [Table 26.2](#).<sup>303,304,305</sup>

## **TABLE 26.2 Semen Analysis: Normal Reference Values**

<b>Volume</b>	1.5–5.0 mL
<b>pH</b>	>7.2
<b>Viscosity</b>	<3 (scale 0–4)
<b>Sperm concentration</b>	>20 million/mL
<b>Total sperm number</b>	>40 million/ejaculate
<b>Percent motility</b>	>50%
<b>Forward progression</b>	>2 (scale 0–4)
<b>Normal morphology</b>	>50% normal <sup>303</sup> >30% normal <sup>304</sup> >14% normal <sup>305</sup>
<b>Round cells</b>	<5 million/mL
<b>Sperm agglutination</b>	2 (scale 0–3)

Over time, the methods and normal reference values for determining sperm concentration and motility have changed little, but those for sperm morphology have changed rather substantially. Using the most recent and rigorous standard, even fertile men have relatively few normal sperms. The rationale for the change in the morphology standard and its clinical relevance are discussed below (see Sperm Morphology).

In 2010, the WHO published revised **lower reference limits** for semen analyses, which represent the fifth centile in a population of over 1,900 men from 8 countries on 3 continents whose partners conceived within 12 months ([Table 26.3](#)).<sup>306</sup>



**TABLE 26.3 Semen Analysis: Lower Reference Limits (95% CI) in Fertile Men**

<b>Volume</b>	1.5 (1.4–1.7) mL
<b>Sperm concentration</b>	15 (12–16) million/mL
<b>Total sperm number</b>	39 (33–46) million/ejaculate
<b>Total motility</b>	40 (38–42) %
<b>Progressive motility</b>	32 (31–34) %
<b>Normal morphology</b>	4 (3–4) %
<b>Vitality</b>	58 (55–63) %

These data provide clinically relevant reference values for use in the evaluation of infertile men and in assessing their prognosis for achieving pregnancies with their partners.

## Ejaculate Volume and pH

A low or absent ejaculate volume suggests the possibility of failed emission, incomplete collection, a short abstinence interval, CBAVD, ejaculatory duct obstruction, hypogonadism, or retrograde ejaculation. Other semen parameters can help to differentiate the cause.

**The majority of semen volume comes from the seminal vesicles, which share a common embryology with the vasa deferentia.** Seminal vesicle secretions are alkaline and contain fructose. Because the seminal vesicles are hypoplastic or absent in most men with CBAVD, they generally produce a low-volume acidic (pH < 7.2) ejaculate that contains little or no fructose and reflects the greater contribution of acidic prostatic secretions.<sup>307,308,309</sup> Men with ejaculatory duct obstruction produce an ejaculate having similar characteristics because the ejaculatory ducts are formed by the union of the vasa with the ducts exiting the seminal vesicles, proximal to the prostate; semen fructose concentrations decrease with increasing severity of ejaculatory duct obstruction.<sup>310,311,312</sup> **When both ejaculatory ducts are completely obstructed, the**

**semen is acidic (containing only prostatic secretions) and contains neither fructose nor sperms.** Hypogonadal men with either primary or secondary testicular failure also may exhibit low ejaculate volumes because the secretions of the seminal vesicles and prostate are stimulated by androgens; volume is therefore decreased when androgen levels are low.

**A postejaculatory urinalysis can detect retrograde ejaculation and should be considered whenever the ejaculate volume is less than 1 mL, except when hypogonadism, CBAVD, collection problems, or a short abstinence interval offers an obvious explanation.** When indicated, the postejaculatory urinalysis involves centrifugation for 10 minutes at no less than 300g, followed by microscopic examination of the pellet (400×). **In men with no or low semen volume and azoospermia (no sperms in the ejaculate), the observation of any sperm on postejaculatory urinalysis suggests retrograde ejaculation.** More substantial numbers of sperms must be observed in men with low-volume oligospermia before making the diagnosis of retrograde ejaculation because sperms found in the urine may simply have been washed from the urethra during urination.<sup>307</sup>

## **Sperm Concentration and Total Sperm Count**

Azoospermia describes the absence of sperms on standard microscopic examination. The prevalence of azoospermia is approximately 1% in all men<sup>313</sup> but up to 10–15% in infertile men.<sup>314</sup> To establish the diagnosis, the semen specimen should be centrifuged at high speed (3,000g for 15 minutes) and the pellet examined at high magnification (400×)<sup>305</sup>; **the absence of sperms should be documented on at least two separate occasions.** Azoospermia is generally classified as obstructive (normal sperm production) or nonobstructive (decreased or absent spermatogenesis).

Obstructive azoospermia may result from a blockage anywhere in the ductal system, from the efferent ductules to the ejaculatory ducts, as the consequence of severe infection, iatrogenic injury during scrotal or inguinal surgery, or congenital anomalies (CBAVD); approximately 40% of azoospermic men have an obstruction.<sup>307</sup> Nonobstructive azoospermia is caused by intrinsic testicular disease (primary testicular failure) or endocrinopathies and other conditions that suppress spermatogenesis (secondary testicular failure). Men with nonobstructive azoospermia may have low-level sperm production that is insufficient to drive epididymal transport and to permit sperms to enter the ejaculate.<sup>315</sup> Careful examination of a centrifuged semen sample will identify sperms in the ejaculates of up to one-third of men with a preliminary diagnosis of nonobstructive azoospermia.<sup>316</sup> The observation has practical significance because men in whom even a modest number of sperms can be recovered from the ejaculate may

not require surgical sperm retrieval for IVF (testicular sperm extraction, TESE).

Oligospermia is defined traditionally by a sperm density less than 20 million/mL and is considered severe when the sperm concentration is below 5 million/mL. **The probability of conception increases with increasing sperm concentrations up to approximately 40–50 million/ mL but does not rise further with higher sperm densities.**<sup>297,298</sup> The results of a large US study comparing semen parameters in fertile and infertile men with normal partners indicate that the likelihood of male infertility is increased approximately fivefold (5.3, 95% CI = 3.3–8.3) when sperm density is less than 13.5 million/mL.<sup>297</sup> In an earlier European study of similar design, the density representing the tenth percentile for fertile men was 14 million/mL.<sup>317</sup> These values are consistent with the most recent recommendations from WHO regarding the lower reference limit for fertile men (15 million/mL).<sup>306</sup> Oligospermia may be associated with a varicocele, hypogonadism, or specific microdeletions in the Y chromosome. **Endocrine and genetic evaluation is indicated for men with severe oligospermia** (discussed below).

Total sperm count is simply the product of multiplying the semen volume and sperm concentration. The total sperm count may be normal in oligospermic men when volume is high and also normal when volume is low but density is high. The two parameters fluctuate and must be considered together in making judgments regarding semen quality. Numerous studies have suggested that the average sperm count in men has been decreasing steadily over the past few decades,<sup>318,319</sup> raising concerns that environmental toxins and chemicals having estrogen-like activity (xenoestrogens) might be responsible. However, numerous others have observed no evidence of any significant change.<sup>320,321,322,323,324,325</sup> Most importantly, the prevalence of infertility has not increased significantly over the same intervals, indicating that any decrease in semen quality that may have occurred has had no global clinical impact.

## **Sperm Motility, Forward Progression, Total Motile Count, and Vitality**

Sperm motility is estimated as a percentage of the total sperm population exhibiting any motion. Forward progression generally is graded on an arbitrary scale (grade 0–4) and most often reported as the percentages exhibiting rapid (grade 3–4), slow (grade 2), and nonprogressive motility (grade 0–1). Total progressive motility generally represents an estimate of the percentage of sperms exhibiting purposeful forward motion (grade 2–4). **The probability of conception rises with increasing motility up to approximately 60%.**<sup>297</sup> According to one large US study, the likelihood of male infertility is increased approximately fivefold (OR = 5.6, 95% CI = 3.5–8.3) when progressive motility is less

than 32%.<sup>297</sup> In another study, the threshold separating fertile and infertile men was 45% and the tenth percentile motility for fertile men was 28%.<sup>317</sup> Again, these values compare well with the lower reference value for progressive motility now recommended by the WHO (32%).<sup>306</sup>

The total motile sperm count is calculated from the total sperm count and the percentage of progressively motile sperm and represents an estimate of the total number of active sperms in the ejaculate. Allowing for the inevitable procedural losses associated with processing a semen sample for IUI (up to approximately 50%), the total motile sperm count can be used to estimate the likely processed total motile sperm count, which correlates with the probability of pregnancy achieved with IUI in the treatment of male factor infertility (see Treatment, below).<sup>326,327,328,329,330</sup>

In general, poor sperm motility (asthenospermia) suggests testicular or epididymal dysfunction. Asthenospermia has been associated with sperm autoantibodies (predisposing to aggregation), genital tract infections (leukocytes in the semen), partial obstruction of the ejaculatory ducts or at the site of a vasectomy reversal (reanastomosis), varicoceles, and prolonged abstinence intervals.

Large numbers of viable nonmotile sperms suggest the rare possibility of primary ciliary dyskinesia (Kartagener syndrome), in which sperm tails have a structural abnormality and cannot flagellate. The cilia of the respiratory tract usually also are involved; affected individuals are infertile and predisposed to chronic respiratory tract infections. Diagnosis is made by examination of sperms using electron microscopy.

**When no motile sperms are observed, a sperm vitality test can differentiate viable nonmotile sperms from dead sperms.** One method involves mixing fresh semen with a supravital dye (eosin Y or trypan blue); sperms with intact membrane function do not take up the stain. Another method, the hypo-osmotic sperm swelling test, involves incubation of sperms in a hypo-osmotic solution; the tails of sperms with normal membrane function swell and coil as fluid is transported across the membrane. In men with few or no motile sperms, the hypo-osmotic swelling test can be used to identify living nonmotile sperms for ICSI.<sup>331</sup>

## Sperm Morphology

Sperm morphology reflects the quality of spermatogenesis. Morphologic abnormalities (teratospermia) are categorized by location, involving the head, neck (midpiece), or tail. Cytoplasmic droplets in the midpiece that occupy more than approximately one-half of the area of a normal sperm head represent another specific defect. Sperms classified as normal must be normal in all respects. Teratospermia has been associated with varicocele and with both primary and secondary testicular failure. It may be observed in

association with abnormalities in sperm concentration and motility or occur as an isolated abnormality.

The most recent WHO reference values (since 1999) for the evaluation of sperm morphology are very similar to those known as the Kruger (Tygerberg) or “strict” criteria,<sup>332,333</sup> which arose from efforts to identify predictors of fertilization in IVF cycles. When sperm morphology was judged according to a strict normal standard, fertilization efficiency in vitro correlated with the percentage of morphologically normal sperms.<sup>332,334,335</sup> Conventional fertilization rates were highest when the percentage of normal sperms was 14% or higher, very poor (7–8%) when less than 4% of sperms had normal morphology, and intermediate when values fell between the two threshold values.<sup>332</sup> After several studies confirmed the predictive value of strict sperm morphology in IVF,<sup>336,337,338,339,340,341,342,343</sup> severe teratospermia (0–4% normal sperms by strict criteria) became widely accepted as an indication for ICSI in IVF cycles. However, others have observed no differences in the fertilization, pregnancy, and live birth rates achieved with ICSI and conventional fertilization and argue that isolated teratospermia is not a valid indication for performing ICSI.<sup>344,345,346,347</sup> **Controversy continues, but strict sperm morphology remains the best available predictor of sperm function (the capacity to fertilize a mature oocyte).**

It was logical to anticipate that if strict sperm morphology could predict fertilization efficiency under optimized conditions in vitro, it also might have value for predicting the likelihood of successful fertilization in vivo and help to discriminate fertile and infertile men. A number of studies have examined semen parameters in couples with no known infertility factors who were attempting pregnancy,<sup>298,348</sup> or compared the semen parameters of fertile and infertile men<sup>297,317,341,349</sup>; two have included only men whose partners had no apparent infertility factors.<sup>297,317</sup> **Whereas sperm concentration and progressive motility had value for distinguishing fertile from infertile men, strict sperm morphology (as determined by an individual having extensive training and experience) was the one most discriminating value.**<sup>297,317</sup> In the larger of the two studies, the likelihood of male infertility was increased approximately fourfold (OR = 3.8, 95% CI = 3.0–5.0) when strict sperm morphology was less than 9% normal.<sup>297</sup> The 9% threshold value had a sensitivity of 43% and a specificity of 81% for identifying infertile men; lowering the threshold value to 5% normal forms decreased sensitivity to only 19% but increased specificity to 94%.<sup>297</sup> In a smaller study of similar design, the threshold value that identified infertile men was 10% and the value corresponding to the tenth centile among fertile men was 5% normal forms.<sup>317</sup>

Strict sperm morphology is perhaps most relevant for couples with mild oligospermia or asthenospermia or with unexplained infertility (normal ovulatory

function, female reproductive anatomy, and semen parameters). In such couples, IUI (with or without ovarian stimulation) and IVF are the treatment options that offer the greatest likelihood for success (Chapter 27). Most,<sup>350,351,352,353</sup> but not all,<sup>354,355</sup> studies have observed that cycle fecundability in IUI cycles correlates with the proportion of morphologically normal sperms and is generally poor when strict morphology is less than 5% normal. **Although no threshold value excludes the possibility of pregnancy with expectant management or IUI, the relationship between strict sperm morphology and cycle fecundability with IUI merits careful consideration and discussion when planning treatment for couples with male factor and unexplained infertility.** Other important considerations include age of the female partner, the duration of infertility, and the comparative costs, logistics, risks, and prognosis associated with alternative treatment strategies, including IVF with and without ICSI.

It is important to emphasize that strict sperm morphology values, like other semen parameters, vary among specimens within individuals, among technologists within laboratories, and among laboratories.<sup>333,356</sup> A rigorous quality control program helps to ensure accuracy and consistency.<sup>357,358</sup> Unfortunately, relatively few of the laboratories that perform routine semen analyses have sufficient test volume and the highly trained and experienced personnel required to provide a valid assessment of strict sperm morphology. **Consequently, earlier WHO standards for sperm morphology (1987, 1992) that classify more sperms as normal are still widely used in most hospital laboratories.**<sup>303,304</sup> Although morphology assessments using the earlier standards have little value, results for semen volume, sperm concentration, and motility are still informative and can reveal an obvious male factor. However, a more sophisticated semen analysis, including strict sperm morphology, merits serious consideration before implementing treatment for couples with male factor or unexplained infertility.

## Round Cells and Leukocytospermia

Epithelial cells, prostate cells, immature sperm (round spermatids, spermatocytes), and leukocytes all appear as “round cells” and cannot be differentiated in a routine semen analysis. **When the round cell count exceeds 5 million/mL, additional studies should be performed to differentiate leukocytes from immature sperms and to identify those men having true leukocytospermia (>1 million leukocytes/mL) who may require additional evaluation for genital tract infection or inflammation.** Any of a variety of special stains, biochemical tests, and immunohistochemical techniques can be used to identify the proportion of round cells that is leukocytes.<sup>359,360</sup> Although leukocytospermia has been implicated as a cause of poor sperm motility and function,<sup>361</sup> more recent studies have failed to demonstrate any association between the leukocytospermia in men with chronic prostatitis and abnormal semen parameters.<sup>362</sup>

Nevertheless, documented leukocytospermia generally is regarded as an indication for semen culture (*Mycoplasma hominis*, *Ureaplasma urealyticum*, Chlamydia). When cultures are performed, the penis should be washed carefully with Betadine before sample collection to reduce the likelihood of contamination from skin flora. For reasons unknown, leukocytospermia unrelated to infection or inflammation also may be observed in the semen of men with spinal cord injuries.<sup>363</sup>

## **Semen Viscosity**

The viscosity of semen is evaluated routinely and graded on an arbitrary scale (grade 0–4). Seminal hyperviscosity is relatively uncommon and its causes have not been clearly defined. Not surprisingly, hyperviscosity has been associated with asthenospermia.<sup>364,365</sup> Although genital tract infections and sperm autoantibodies have been implicated as causes of seminal hyperviscosity, evidence for the association is lacking.<sup>366</sup> Like abnormalities of pH and fructose levels, increased semen viscosity suggests the possibility of dysfunction in the accessory glands (prostate, seminal vesicles),<sup>367</sup> but in practice, the parameter has relatively little importance.



## Specialized Tests

Although all of the major semen parameters (concentration, motility, morphology) have impact on fertility when clearly abnormal, they do not measure or answer what is arguably the most important question: can the sperm effectively attach to, penetrate, and fertilize the partner's ova? Strict sperm morphology is a useful indirect measure of sperm function by virtue of its correlation with fertilization rates in vitro, but the parameter leaves much to be desired and generally is available only in specialty andrology laboratories associated with IVF centers.

**Unfortunately, although a wide assortment of specialized tests and procedures has been developed to evaluate sperm attachment to the zona pellucida, penetration of the oocyte membrane, or the release of acrosomal enzymes, we still have no reliable validated test of sperm function.** Because we do not yet understand, cannot measure, and have no way to correct a suspected sperm function abnormality, attention has focused on ICSI as a way to negate or circumvent sperm function abnormalities. However, the need for a reliable sperm function test persists, because IVF and ICSI are not practical options for a great many infertile couples and all would like to use their available time and resources in the most efficient and effective way possible<sup>368</sup>; the time and expense associated with treatments involving IUI might be avoided if there was good evidence to indicate that only ICSI offered a realistic likelihood for success.

## Sperm Autoantibodies

The blood-testis barrier normally isolates sperms from immune recognition (sperms develop after immunocompetence is established), but if it is disrupted and sperms are exposed to blood, an antigenic response may result. Risk factors for antisperm antibodies include ductal obstruction, previous genital infection, testicular torsion or trauma, and sterilization reversal (vasovasostomy or vasoepididymostomy).<sup>369</sup> Sperm autoantibodies can be found in the serum, but evidence indicates they have no clinical significance.<sup>370,371</sup> In contrast, antibodies bound to sperm may be clinically relevant because they may interfere with sperm motility or prevent fertilization.<sup>372,373</sup>

Marked sperm clumping or agglutination, like isolated asthenospermia, may signal the presence of sperm autoantibodies, but neither is observed commonly. Some also regard unexplained infertility as an indication for antisperm antibody testing. The two most widely used tests for detection of sperm autoantibodies involve the use of beads or latex particles with attached antibodies (raised against human immunoglobulins) that bind to antibodies on the surface of sperms.<sup>305</sup> The threshold for a positive test is not well established, but antibodies generally are considered clinically important when

more than 50% of sperms are coated. However, the levels of antibody can fluctuate, even without treatment.<sup>374</sup> New research on sperm proteomics may help to link specific sperm proteins with their functions and to identify relevant sperm autoantibodies.<sup>375</sup>

Pregnancy rates are reportedly lower for men with demonstrable antisperm antibodies than for those without antibodies, and among those with antisperm antibodies, pregnancy rates are lower when more than 50% of sperms are antibody bound.<sup>376</sup> Antisperm antibodies have been associated with poor postcoital test results, but routine postcoital testing is no longer performed because results have no proven value (Chapter 27). Because IUI was among the most popular and effective treatments for antisperm antibodies<sup>377</sup> (as it was for presumed cervical factor infertility) and IUI has become a core element of most treatments for unexplained infertility other than IVF (Chapter 27), the results of antisperm antibody testing, like those from postcoital testing, rarely offer any information that affects treatment decisions or outcomes. **Sperm autoantibody testing is seldom any longer performed because when IUI fails or IVF is otherwise indicated, ICSI can effectively circumvent any adverse effects of antisperm antibodies.**<sup>378</sup>

## Sperm Penetration Assay

The zona pellucida surrounding the oocyte blocks entry of more than one sperm and fertilization by sperms of a different species, but if removed by gentle enzymatic digestion, sperms of another species can penetrate the egg. In the sperm penetration assay, zona-free eggs collected from superovulated golden hamsters are incubated with washed human sperms, and the proportion of eggs penetrated or the number of sperm penetrations per egg by the sperms of the test subject is compared to that observed in a parallel incubation using sperms from a known fertile individual.<sup>305,379,380</sup> In theory, the test evaluates four specific sperm functions: capacitation, the acrosome reaction, fusion with the oolemma, and decondensation within the egg cytoplasm.

Unfortunately, the results of the sperm penetration assay are quite sensitive to varying culture conditions and the test procedure has been difficult to standardize. The test relies on spontaneous in vitro or chemically induced acrosome reactions.<sup>381</sup> Test results also vary over time and even proven sperm donors may fail the sperm penetration assay on a given occasion.<sup>382</sup> The predictive value of the sperm penetration assay for IVF or natural conception among infertile couples has varied widely among studies and depends, in large part, on the experience of the individual laboratory.<sup>383,384,385,386</sup> Interestingly, test results also have not consistently correlated with strict sperm morphology, the most commonly accepted predictor of fertilization.<sup>387,388,389</sup> Perhaps most importantly, the test is cumbersome, costly, time-

consuming, and not widely available.

## **Human Zona Binding Assay**

Whereas sperm penetration of zona-free eggs may test the ability of sperms to penetrate the oocyte, it does not, by definition, test the ability of sperms to bind to and penetrate the zona pellucida. The hemizona assay uses bisected zonae derived from human oocytes not previously exposed to sperms and compares the binding of test subject and fertile control sperms.<sup>390,391</sup> Results have been used to predict fertilization in vitro,<sup>392,393</sup> but the limited availability of human zonae and the technical aspects of the test effectively preclude application beyond use as an investigative tool.

## **Computer-Assisted Sperm Analysis**

Computer-assisted sperm analysis (CASA) was developed in efforts to establish a precise, automated, and objective evaluation of sperm concentration and motion characteristics (velocity and head movement). The technology employs sophisticated instruments to generate digitized video images for analysis, but its accuracy is highly dependent on the methods of sample preparation, frame rate, and sperm concentration.<sup>394,395</sup> Although some have found that sperm motility characteristics have predictive value for fertilization in vivo and in vitro, others have not.<sup>396,397,398</sup>

## **Acrosome Reaction**

The acrosome is a membrane-bound structure located at the tip of the sperm head containing proteolytic enzymes necessary for penetration of the zona pellucida ([Chapter 7](#)), and acrosin is one of those enzymes.<sup>399</sup> The acrosome reaction involves the fusion of the acrosome and the plasma membrane, followed by release of the acrosomal enzymes and exposure of the sperm head, which must occur after sperm binding to the zona pellucida. The sperms of infertile men exhibit an increased prevalence of spontaneous acrosome loss and decreased acrosome reactivity in response to treatment with a calcium ionophore.<sup>400</sup> However, the clinical relevance of acrosin measurements and abnormal acrosome reactivity in vitro remains to be established.

## **Biochemical Tests**

Biochemical tests of sperm function include measurements of sperm creatine phosphokinase and reactive oxygen species. Creatine phosphokinase is an important enzyme involved in the generation, transport, and use of energy within the sperm. Studies of the levels or forms of the enzyme in the sperms of fertile and infertile men

have yielded conflicting results.<sup>401,402</sup>

Normal oxygen metabolism generates reactive oxygen species, which may be toxic in excess. In both fertile and infertile men, leukocytes are the principal source of reactive oxygen species, but sperms themselves also produce them. Increased levels have been observed in the semen of infertile men and implicated as a cause of otherwise unexplained male infertility.<sup>403,404,405</sup> Peroxidation of sperm lipid membranes and generation of toxic fatty acid peroxides may interfere with sperm functions.<sup>406</sup> Reactive oxygen species can be detected with chemiluminescent probes, but such tests remain investigational.

## **Sperm Chromatin Structure and DNA**

A significant proportion of infertile men have increased levels of DNA damage that may adversely affect fertility<sup>407,408,409,410,411,412,413</sup> even when all standard semen parameters are normal.<sup>414</sup> Men with abnormal semen parameters often exhibit high levels of DNA fragmentation, but the same can be observed in men with normal semen parameters.<sup>407,411,415,416,417</sup> Recently developed tests of sperm chromatin structure and DNA fragmentation provide a measure of sperm chromatin and nuclear integrity,<sup>418</sup> but their clinical utility has not been established. A meta-analysis including 13 relevant studies involving over 2,000 treatment cycles concluded that the small association between sperm DNA integrity test results and pregnancy in IVF and ICSI cycles is not sufficient to warrant their routine use in the evaluation of infertile men.<sup>419</sup>

# Endocrine Evaluation

Endocrine disorders involving the hypothalamic-pituitary-testicular axis are well recognized but uncommon causes of male infertility and are extremely uncommon in men having normal semen parameters. **Indications for endocrine evaluation in infertile men include an abnormal semen analysis (particularly a sperm concentration <10 million/mL), sexual dysfunction (decreased libido, impotence), and other clinical symptoms or findings that suggest a specific endocrinopathy.**<sup>307</sup> A basic endocrine evaluation of the infertile male involves measurements of serum FSH and total testosterone and will detect the vast majority of clinically significant endocrinopathies.<sup>420</sup>

When the total testosterone level is low (<300 ng/dL), the assay should be repeated to confirm the finding, and a serum free testosterone, LH, and prolactin should be obtained.<sup>307,421</sup> Together, the levels of FSH, LH, and testosterone help to differentiate the clinical condition. **In men with hypogonadotropic hypogonadism, generally all three hormone levels are distinctly low. In men with abnormal spermatogenesis, the FSH level may be normal or high and LH and testosterone levels are normal. Those with testicular failure exhibit high levels of FSH and LH and a low or normal testosterone concentration. Men with a prolactin-secreting pituitary tumor generally have normal or low gonadotropin concentrations, a low serum testosterone, and an elevated prolactin level. In those with hypogonadotropic hypogonadism, with or without hyperprolactinemia, MRI of the hypothalamic-pituitary region is indicated to exclude a mass lesion.**

In infertile men with severe oligospermia (<5 million/mL), low testosterone levels (<300 ng/dL), and normal gonadotropin concentrations, evaluation might be expanded to include a serum estradiol and calculation of the testosterone (ng/dL)/estradiol (pg/mL) ratio, because those with low values (<10) may benefit from treatment with an aromatase inhibitor.<sup>422,423</sup>

# Urologic Evaluation

**If not performed earlier, grossly abnormal semen parameters are indication for a thorough physical examination by a urologist or other specialist in male reproduction; some men also may require further urologic evaluation.**

In normal men, the testes are firm and measure 15–25 mL in volume.<sup>424</sup> Small soft testes suggest testicular failure. Epididymal fullness suggests obstruction in men with azoospermia.<sup>425</sup> The diagnosis of CBAVD is made by physical examination alone and does not require scrotal sonography or exploration.<sup>308,309</sup> Palpation of the spermatic cord (erect and supine, with and without Valsalva) may reveal a varicocele,<sup>426</sup> which can be graded (grade 1–3) according to severity.<sup>427</sup> Digital rectal examination defines the size and symmetry of the prostate and may reveal the presence of midline cysts or dilated seminal vesicles suggesting ejaculatory duct obstruction.

**Transrectal ultrasonography** is indicated for the diagnosis of ejaculatory duct obstruction in men with severe oligospermia or azoospermia, palpable vasa, low-volume ejaculates, and normal testis volume, particularly when the semen is acidic and contains little or no fructose.<sup>307,428</sup> Vasography offers an alternative method for diagnosis of ejaculatory duct obstruction, but transrectal ultrasonography is less invasive and avoids the risk of vasal injury.<sup>429</sup> Observations of midline cysts, dilated seminal vesicles, or ejaculatory ducts suggest, but do not establish, the diagnosis of ejaculatory duct obstruction. Conversely, the absence of any such findings does not exclude the possibility. Seminal vesicle aspiration and vesiculography under transrectal ultrasound guidance provides the means to make a definitive diagnosis; any sperms retrieved can be cryopreserved for use in IVF with ICSI.<sup>430</sup> Definitive treatment requires transurethral resection of the ejaculatory ducts.<sup>431</sup>

**Transscrotal ultrasonography** can help to clarify uncertain physical findings or to confirm the presence of a scrotal mass. It also may reveal nonpalpable varicoceles, but there is no evidence to indicate they have clinical importance.<sup>282</sup>

**Renal ultrasonography** is indicated for men with unilateral or bilateral vasal agenesis. Approximately 25% of men with unilateral vasal agenesis and 10% of men with CBAVD have unilateral renal agenesis.<sup>432</sup>

**Testis biopsy** may be performed for diagnostic purposes in azoospermic men. Those with elevated serum FSH levels do not require a diagnostic biopsy because a high FSH concentration is diagnostic for abnormal spermatogenesis. Although biopsy may be performed to determine the likelihood that sperms can be retrieved for IVF with ICSI, results may not be all that helpful because sperm production can be limited to

specific foci within the testes. In contrast, diagnostic biopsy is indicated for azoospermic men with normal testicular size, at least one palpable vas deferens and a normal serum FSH level, because the normal FSH does not guarantee that spermatogenesis is normal. When biopsy is performed, a portion of testicular tissue can be cryopreserved for use in a future IVF/ICSI treatment cycle to avoid the need for a second procedure. A biopsy that reveals normal spermatogenesis implies obstruction at some level, which then must be defined by surgical exploration with or without vasography (see Surgical Treatment, below).<sup>307</sup>

# Genetic Evaluation

Genetic abnormalities may cause infertility by interfering with sperm production or transport. Currently, those most relevant to male infertility and its treatment include (1) mutations within the CFTR gene, which are highly associated with CBAVD, (2) chromosomal anomalies resulting in testicular dysfunction (Klinefelter syndrome; 47,XXY), and (3) Y chromosome microdeletions associated with abnormalities of spermatogenesis. These conditions have implications that extend beyond their association with azoospermia and severe oligospermia because they can have consequences for the offspring of affected couples. Ideally, genetic counseling should be offered both before and after genetic testing.

**Mutations of the CFTR gene are highly associated with CBAVD; almost all men with cystic fibrosis have CBAVD and at least two-thirds of men with CBAVD have a demonstrable CFTR mutation.**<sup>433,434</sup> The gene encodes a protein involved in the formation of the seminal vesicles and the reproductive ductal system in men. Although approximately 4% of Caucasian men carry a known CFTR gene mutation, clinical CBAVD is much less common because penetrance is low in heterozygous individuals.<sup>435</sup> Common speculation, and the prudent clinical assumption, is that virtually all men with CBAVD may have such mutations, some of which have a low carrier frequency and have simply not yet been defined. It is important to note that the spectrum of vasal aplasia includes not only CBAVD but also unilateral absence of the vas deferens, bilateral partial absence of the vas or epididymides, and epididymal obstruction. **Men with CBAVD or less severe forms of vasal aplasia, and their female partners, should be screened for CFTR mutations before any attempts at pregnancy via ART to determine the risk for transmitting cystic fibrosis or CBAVD to offspring.**

The overall prevalence of **chromosomal anomalies** in infertile men is approximately 7% and inversely related to sperm concentration; the prevalence is highest in azoospermic men (10–15%), lower in oligospermic men (approximately 5%), and very low in men with normal semen quality (<1%).<sup>436,437</sup> By far, the most common chromosomal anomaly in infertile men is Klinefelter syndrome (47,XXY, 46,XY/47,XXY), which accounts for about two-thirds of chromosomal abnormalities in infertile men.<sup>438</sup> Structural chromosomal abnormalities (translocations, inversions) make up the majority of the remainder.<sup>439</sup> The partners of affected men are at increased risk for miscarriage and birth of children with aneuploidy and congenital anomalies. **Karyotyping should be offered to men with nonobstructive azoospermia or severe oligospermia (<5 million/mL) before their sperms are used for IVF with ICSI.**<sup>307</sup> Embryo biopsy and preimplantation genetic diagnosis using fluorescence in situ



hybridization or other techniques to evaluate chromosomal composition can be used to identify normal embryos suitable for transfer.<sup>440</sup>

Approximately 8% of azoospermic and 2–5% severely oligospermic infertile men harbor a **Y chromosome microdeletion** that cannot be detected with a standard karyotype but can be identified using more sophisticated genetic techniques.<sup>226,227,441</sup> Most such microdeletions occur in regions of the long arm of the Y chromosome (Yq11), designated as AZF (azoospermic factor) a (proximal), b (central), and c (distal), which appear to include genes necessary for normal spermatogenesis.<sup>442</sup> Many men with microdeletions in the AZFc region are only severely oligospermic,<sup>443,444</sup> and those who are azoospermic generally produce sufficient sperms to allow their recovery by testis biopsy. In contrast, the prognosis for sperm recovery in men with microdeletions in the AZFa or AZFb region is very poor.<sup>445,446,447</sup> Microdeletions in the AZFd region are associated with normal spermatogenesis, and their clinical significance is unknown.<sup>448</sup>

Sons of men with Y chromosome microdeletions can be expected to inherit the defect and its clinical consequences.<sup>449,450,451</sup> Until recently, infertility was the only known clinical consequence of Y microdeletions, but a 1.6-Mb deletion that removes part of the AZFc region (known as the gr/gr deletion) now has been associated with an increased risk for developing testicular germ cell tumors.<sup>452</sup> **Screening for Y chromosome microdeletions should be offered to all men with nonobstructive azoospermia or severe oligospermia (<5 million/mL) who are candidates for IVF with ICSI.**<sup>307</sup>

# **MEDICAL TREATMENT FOR MALE INFERTILITY**

---

With a few specific and important exceptions, male infertility generally is not amenable to medical treatment. Careful evaluation can identify those men with treatable conditions who may benefit from medical therapy.

# Hypogonadotropic Hypogonadism

**Men with hypogonadotropic hypogonadism represent one group in which medical treatment can be successful, after its cause has been defined.** Most affected men have a congenital isolated gonadotropin deficiency associated with abnormal puberty, due to absent or abnormal pulsatile hypothalamic GnRH secretion. The endocrinopathy may be genetic in origin, resulting from failure of GnRH neuronal migration during embryogenesis (Kallmann syndrome),<sup>453</sup> or idiopathic. When the disorder has onset after puberty, affected men are virilized but hypogonadal, impotent, and azoospermic.

Postpubertal hypogonadotropic hypogonadism is uncommon but may arise as the consequence of a hypothalamic or pituitary tumor or an inflammatory process (sarcoidosis, hemochromatosis, autoimmune hypophysitis).<sup>454</sup> Pituitary tumors, specifically prolactinomas, are the most common cause. Men with prolactinomas often present with impotence and androgen deficiency. In contrast to the microadenomas commonly identified in women, tumors in men are more often large (macroadenomas). The hypogonadism associated with hypothalamic or pituitary mass lesions may result from hyperprolactinemia and disruption of pulsatile GnRH secretion or from direct effects on the pituitary via compression of pituitary gonadotropes.

Hypogonadotropic hypogonadism due to hyperprolactinemia is generally uncommon in infertile men (approximately 1%)<sup>455</sup> but is amenable to treatment with dopamine agonists when it is identified. Treatment with bromocriptine or cabergoline can effectively restore normal prolactin and testosterone levels and, subsequently, improve libido, potency, semen quality, and fertility in hyperprolactinemic hypogonadal men.<sup>456,457,458,459</sup> Increased testosterone levels and potency are observed within approximately 3–6 months after normal prolactin levels are achieved; changes in semen quality generally take longer.<sup>458,459</sup> Improved semen quality may be expected, but not all men achieve normal semen parameters. In eugonadal infertile men with mild hyperprolactinemia, dopamine agonist treatment promptly restores normal prolactin levels but has little effect on semen quality.<sup>455,460</sup> Although prolactin levels are modestly higher in infertile than in fertile men, there is no evidence to indicate that dopamine agonist treatment in euprolactinemic men with idiopathic oligospermia or asthenospermia can improve semen quality or fertility.<sup>461</sup>

**Because concerns regarding delayed puberty generally arise well before any active interest in fertility, most men with congenital hypogonadotropic hypogonadism are treated first with hCG (to stimulate Leydig cell testosterone production) or exogenous testosterone; either can induce secondary sexual development, but neither can initiate and support normal spermatogenesis.**

**In contrast, hCG alone (2,000–5,000 IU three times weekly) often can restore meaningful spermatogenesis in men with adult onset of hypogonadotropic hypogonadism.**<sup>462,463</sup> Treatment always should begin with hCG alone (as a substitute for LH), without FSH, for several reasons: (1) hCG stimulates Leydig cells to produce testosterone, resulting in the high intratesticular testosterone concentrations required to stimulate and support spermatogenesis; (2) whereas hCG alone may be sufficient to stimulate spermatogenesis, FSH alone is not<sup>63</sup>; and (3) the annual costs of hCG treatment are substantially lower than the costs of treatment with human menopausal gonadotropins (hMG containing both FSH and LH) or recombinant FSH. During treatment, the serum testosterone concentration should be measured every 1–2 months for the first 3–4 months, aiming for a level between 400 and 900 ng/dL. If not achieved within that interval, dosage should be adjusted accordingly. Some require doses as low as 500 IU and others as much as 10,000 IU. The sperm count also should be monitored at regular intervals. In most, a normal sperm count can be restored within 6 months, but some require treatment for up to 24 months.<sup>464</sup> However, even low sperm concentrations do not preclude fertility.<sup>465</sup>

**In men with congenital hypogonadotropic hypogonadism and those with postpubertal onset who do not respond to treatment with hCG alone, normal spermatogenesis can be induced by combined treatment with hCG and hMG or pure FSH (75–150 IU three times weekly).**<sup>63,466</sup> Treatment with exogenous testosterone and FSH is ineffective because it cannot generate the highly concentrated intratesticular testosterone concentrations required for normal spermatogenesis.<sup>63</sup> The sperm count should be monitored at least monthly to detect a meaningful trend, because concentrations can fluctuate. As with hCG-only treatment, maximum sperm concentrations generally are achieved within 6–24 months. Once spermatogenesis is established by combined treatment with hCG and FSH/hMG, it can be maintained by hCG alone for extended intervals, although semen quality gradually declines again without further FSH treatment.<sup>467</sup>

**Men with hypogonadotropic hypogonadism unrelated to hyperprolactinemia or a hypothalamic or pituitary mass lesion also can be treated with exogenous pulsatile GnRH therapy,**<sup>468,469</sup> generally administered subcutaneously via a portable programmable pulsatile infusion pump in doses individually titrated to maintain normal adult male serum LH levels.<sup>470,471</sup> Treatment with pulsatile exogenous GnRH can successfully restore normal levels of gonadotropin secretion and thereby induce testosterone production and spermatogenesis. Although it is a very specific treatment for men with deficient endogenous GnRH secretion, exogenous pulsatile GnRH therapy is costly, is cumbersome, and may require extended periods of time to achieve the desired result. Normal serum gonadotropin levels can be achieved

within little more than a week of treatment and normal serum testosterone concentrations within just a few weeks, but stimulation of spermatogenesis takes considerably longer.<sup>472,473</sup> Evidence of spermatogenesis may be observed within a year after treatment with pulsatile exogenous GnRH begins, but up to 2 years of therapy may be required to achieve maximum testicular growth, spermatogenesis, and fertility. The best predictors of response are a postpubertal onset of hypogonadotropic hypogonadism, absence of cryptorchidism, and a serum inhibin B concentration greater than 60 pg/mL.<sup>469,474</sup> Pulsatile GnRH and gonadotropin treatment have comparable efficacy for stimulating spermatogenesis.<sup>475,476</sup>

# Eugonadotropic Hypogonadism

Men with severe oligospermia (<5 million sperms/mL), low serum testosterone levels (<300 ng/dL), and an abnormally low serum testosterone (ng/dL)/estradiol (pg/mL) ratio (<10) may benefit from medical treatment with an aromatase inhibitor. In such men, treatment (testolactone 50–100 mg twice daily, anastrozole 1 mg daily) can normalize ratios and improve semen quality.<sup>422,423</sup>

# Hypergonadotropic Hypogonadism

**There is no evidence that any form of medical treatment can improve semen quality and fertility in infertile men with hypergonadotropic hypogonadism.** For men with complete spermatogenic failure, the only treatment options are insemination with donor sperms and adoption. For those with severe oligospermia, IVF with ICSI still may offer a realistic chance for success, but preliminary genetic evaluation is strongly recommended, as described earlier.

# Retrograde Ejaculation

Men with documented retrograde ejaculation may benefit from medical treatment with sympathomimetics (imipramine 25 mg twice daily or 50 mg at bedtime, pseudoephedrine 60 mg or ephedrine 25–50 mg four times daily, phenylpropanolamine 50–75 mg twice daily), directed at control of the internal sphincter. Alternatively, sperms can be recovered directly from the bladder after masturbation; for best results, urine pH and osmolality (300–380 mOsm/L) must be carefully controlled by alkalinizing the urine (sodium bicarbonate 650 mg four times daily, beginning 1–2 days before collection) and managing fluid intake.<sup>477,478</sup> When such efforts prove cumbersome or ineffective, the bladder can be drained and filled with buffered medium (approximately 100 mL) immediately before ejaculation. In men with ejaculatory failure, electroejaculation may be required.<sup>479</sup> If sufficient numbers of motile sperms can be recovered, IUI may be performed, and if not, IVF and ICSI may be necessary.



# Leukocytospermia

Leukocytospermia has been associated with other abnormal semen parameters,<sup>480</sup> and antibiotic treatment (doxycycline, erythromycin, trimethoprim-sulfamethoxazole, or a quinolone) clearly is indicated for men with symptomatic genital tract infections. **However, antibiotic treatment does not improve semen parameters in men with asymptomatic leukocytospermia<sup>481</sup> and often fails even to decrease the numbers of leukocytes to normal levels (<1 million/mL).<sup>482,483</sup>** Leukocytospermia often is episodic and does not accurately predict genital tract infection.<sup>484</sup> Moreover, there is little evidence it has any adverse effects on fertility.<sup>485</sup> Treatment therefore probably is best limited to men with documented genital tract infections.

# Idiopathic Male Infertility

Most infertile men are eugonadotropic, normally virilized, and otherwise healthy but have low sperm density or other semen abnormalities for which the cause is unknown. Idiopathic male subfertility is common, and a wide assortment of empiric medical treatments has been described; androgens, gonadotropins, and antiestrogens have received the most attention. **Unfortunately, no medical treatment has proven reliably effective for improving semen parameters or fertility in men with idiopathic subfertility.**

**Androgen therapy** has been advocated as a means to stimulate spermatogenesis, directly by increasing intratesticular androgen concentrations and indirectly via a “rebound” increase in pituitary gonadotropin secretion after an interval of androgen-induced suppression. However, the results of a meta-analysis of 11 randomized clinical trials involving almost 1,000 men indicate that neither treatment strategy reliably improves semen parameters or fertility.<sup>486</sup> There is no substantial evidence that androgen therapy is an effective treatment for idiopathic male infertility.<sup>487</sup>

Results of studies involving the use of **exogenous FSH** to stimulate spermatogenesis directly have been conflicting. Whereas two randomized trials in subfertile men found no evidence that such treatment improves semen quality or fertility,<sup>488,489</sup> others suggest that exogenous FSH may improve semen quality in a subset of men with idiopathic oligospermia in whom testicular biopsy reveals maturation arrest and serum FSH and inhibin B levels are normal.<sup>490,491,492</sup>

Empiric treatment (3–6 months) with either **clomiphene citrate** (25 mg daily) or **tamoxifen** (20 mg daily) commonly is offered to stimulate increased pituitary gonadotropin secretion and spermatogenesis in men with idiopathic subfertility. The results of numerous studies are inconsistent. Whereas treatment appears to benefit some men, there is no reliable method for identifying those who might respond. **Overall, antiestrogen treatment is not effective.** A randomized clinical trial conducted by the WHO involving nearly 200 men and over 1,300 couple-months of observation found no differences among men treated with clomiphene or placebo.<sup>493</sup> Moreover, a meta-analysis including 10 randomized trials involving over 700 men concluded that evidence is insufficient to indicate that antiestrogen treatment improves semen quality or male fertility.<sup>494</sup>

# INTRAUTERINE INSEMINATION

---

Artificial insemination has been used to treat infertile couples for almost 200 years and is an accepted form of treatment for men with severe hypospadias, retrograde ejaculation, neurologic impotence, and sexual dysfunction. Artificial insemination also has been used as a means to overcome oligospermia, asthenospermia, low ejaculate volumes, sperm autoantibodies, and cervical factors. Therapeutic insemination using donor sperms is an established and highly effective treatment for severe and uncorrectable male factor infertility, inherited genetic disorders in the male partner, and single or lesbian women who desire pregnancy. Before the advent of IVF and ICSI, therapeutic donor insemination was the only viable treatment option for couples with severe male factor infertility, and it remains highly effective when ART is rejected or fails.<sup>495</sup>

Artificial insemination may be performed by depositing sperms into the cervical os or directly into the uterus, but IUI is now almost universally performed, for several reasons. First, when trying to overcome the limitations of decreased sperm density or motility in the treatment of male factor infertility, cervical insemination offers no significant advantage over what can be achieved by intercourse. Second, whereas the potential for reactions to the proteins, prostaglandins, and bacteria in semen severely limits the volume of untreated semen (and thus the numbers of sperms) that can be delivered to the upper female genital tract, IUI with a “washed” sperm concentrate (devoid of seminal plasma) delivers most of the sperms in an ejaculate. **Most importantly, IUI yields substantially better overall results than does cervical insemination.** In one meta-analysis including 12 separate studies involving nearly 700 women and over 2,000 insemination cycles, the overall pregnancy rate per cycle was 18% for women receiving IUI, compared to 5% for women who received cervical insemination; considering only the 10 studies in which frozen donor sperms were used, the pregnancy rate per cycle with IUI was more than twice that of cervical insemination (OR = 2.63, 95% CI = 1.85–3.73).<sup>496</sup> An earlier analysis including seven studies yielded similar results (OR = 2.4, 95% CI = 1.5–3.8).<sup>497</sup>

It is difficult to gauge the effectiveness of IUI using the sperms of infertile men because almost all of the many published series examining IUI cycle outcomes have included couples with a variety of infertility factors and have employed combined treatment with IUI and empiric ovarian stimulation. There are ample data from retrospective studies of outcomes in therapeutic donor insemination cycles (IUI with or without ovarian stimulation), but the results achieved using infertile partner sperms cannot be expected to equal those using normal donor sperms. **Considering all of the relevant variables, the available data suggest that cycle fecundity ranges between**

**3% and 10% when IUI is performed using infertile partner sperms<sup>326,498,499,500,501</sup> and is approximately 3 times higher (9–30%) when donor sperms are used.<sup>501,502,503,504,505,506,507</sup>**

Regardless whether infertile partner sperms or frozen donor sperms are used, the methods for sperm preparation, the timing and technique of IUI, and the influence of other infertility factors on prognosis are largely the same. The number, motility, and morphology of frozen donor sperms generally are not limiting because sperm donors are highly selected for their semen quality, but semen parameters definitely do affect the prognosis for success with IUI using infertile partner sperms.

# Semen Parameters and Prognosis

Not surprisingly, the likelihood for success with IUI using infertile partner sperms depends, to some extent, on the severity of the semen abnormality. Sperm density, motility, and morphology all have influence on success rates.

The probability of successful IUI increases with the number of total motile sperms inseminated. **Best results are achieved when the number of total motile sperms exceeds a threshold of approximately 10 million.**<sup>326,328,498</sup> Higher counts do not further increase the likelihood for success<sup>498,508</sup> and IUI is very seldom successful when fewer than 1 million total motile sperms are inseminated.<sup>499,509</sup> Combining the yield from two ejaculates obtained approximately 4 hours apart may increase the numbers of sperms available from oligospermic men.<sup>510</sup>

As might be expected, considering that strict sperm morphology has some predictive value for successful conventional fertilization in vitro,<sup>332,333</sup> the percentage of morphologically normal sperms (strict criteria)<sup>305</sup> appears to have similar predictive value for IUI. Numerous studies have examined the correlation between strict sperm morphology and IUI cycle outcomes. Most,<sup>350,351,352,353,511</sup> but not all,<sup>354,355</sup> have found a strong relationship between the two. Like the results observed in IVF cycles, the probability for success with IUI rises with the percentage of morphologically normal sperms. **Success rates with IUI are highest when 14% or more of the sperms have normal morphology, intermediate with values between 4% and 14%, and generally quite poor when fewer than 4% of sperms are normal.**<sup>350</sup> In general, therefore, couples with male factor infertility involving severe teratospermia (<4% normal sperms) may be best advised to apply their available resources to IVF and ICSI when that is possible.

## Other Prognostic Factors

Needless to say, the prognosis for success with IUI in the treatment of male factor infertility is best when there are no other coexistent infertility factors. Most specifically, the prognosis is greatly influenced by the age of the female partner, the consistency and quality of her ovulatory function, and the condition of her reproductive anatomy. The extent to which these additional factors should be evaluated before treatment with IUI begins must be individualized.

### Maternal Age

Maternal age is a key variable in all infertile couples. Even when donor sperms are used, the probability for success declines progressively with increasing maternal age.<sup>503,506,512,513,514</sup> Cycle fecundability and cumulative pregnancy rates in women under age 35 inseminated with donor sperms (20% per cycle, 88% after up to 7 cycles) equal those observed in normal fertile couples but are lower for women between ages 35 and 40 (12% per cycle, 65%) and those over age 40 (6% per month, 42%).<sup>515</sup> Ovarian reserve testing ([Chapter 27](#)) merits consideration when the female partner is over age 35; has a family history of early menopause, previous ovarian surgery, chemotherapy, or radiation; and is a smoker or previously has responded poorly to exogenous gonadotropin stimulation. Women with a poor ovarian reserve have a significantly reduced probability for success with IVF and, by inference, likely have a relatively poor chance for success with IUI.

### Ovulatory Function

**At a minimum, it is certainly prudent to assess ovulatory function by some objective means when the treatment plan does not include empiric ovarian stimulation (discussed below).** Ovulatory disorders are common, even in women seeking therapeutic donor insemination.<sup>513,515,516,517</sup> Ovulation induction increases success rates with therapeutic donor insemination for women with ovulatory dysfunction,<sup>516</sup> although cycle fecundability remains lower than in women with spontaneous ovulatory cycles.<sup>512,518</sup>

### Uterine and Tubal Factors

**Hysterosalpingography (HSG) is recommended for women over age 35 and when the medical history or physical examination raises suspicion of endometriosis or uterine or tubal infertility factors because IUI is less likely to succeed in couples with combined male factor and tubal factor infertility; IVF, with or without ICSI,**

**usually is a better treatment option.** In the absence of such suspicions, the likelihood of abnormal HSG results is quite low.<sup>519</sup> If not performed before treatment begins, HSG is recommended for women who fail to conceive after 4–6 therapeutic donor insemination cycles. Laparoscopy and hysteroscopy are unnecessary for most women but appropriate for those with an abnormal HSG or signs or symptoms of advanced pelvic disease.

# Empiric Ovarian Stimulation

Empiric ovarian stimulation with clomiphene citrate or exogenous gonadotropins is commonly combined with IUI in the treatment of couples with male factor infertility, based on observations that cycle fecundability (probability of pregnancy per cycle) is higher after combined treatment than after IUI or ovarian stimulation alone in couples with unexplained infertility.<sup>500,520,521</sup> Although the value added by ovarian stimulation when IUI is performed using infertile partner sperms is unproven, data derived from large case series of therapeutic donor insemination cycles provide some useful insight.

The cycle fecundability observed in spontaneous and clomiphene-stimulated therapeutic donor insemination cycles is similar (6–13%),<sup>503,522,523</sup> suggesting that clomiphene stimulation has little or no added value. It is possible, but unproven, that clomiphene treatment might have benefits limited to cycles in which it achieves multifollicular development and ovulation. In contrast, exogenous gonadotropin stimulation appears to increase cycle fecundability in therapeutic donor insemination cycles approximately twofold (14–24%).<sup>503,522,523,524</sup> However, the risks (multiple ovulation, ovarian hyperstimulation), costs, and logistical demands associated with gonadotropin treatment are also substantially higher.

The outcomes observed in large case series strongly suggest that exogenous gonadotropin stimulation increases cycle fecundability in therapeutic donor insemination cycles, particularly because combined treatment generally has been added only after inseminations in spontaneous cycles proved unsuccessful. Equivalent or better outcomes have been observed after gonadotropin stimulation even though comparisons were biased against combined treatment because the selected population already had demonstrated intrinsically lower fertility.<sup>503,522,523</sup> In one randomized trial, cycle fecundability in gonadotropin-stimulated cycles (14%) was more than twice that observed in clomiphene-stimulated cycles (6%).<sup>524</sup> By inference, gonadotropin stimulation also might be expected to improve cycle fecundability when IUI is performed using infertile partner sperms. However, because the poorer quality of infertile partner sperms may be the limiting factor, gonadotropin stimulation may have less value than in therapeutic donor insemination cycles.

**When male factor infertility is the diagnosis, and ovulatory function is normal, treatment with IUI alone is reasonable and appropriate. When IUI in spontaneous cycles or indicated clomiphene-induced cycles fails (approximately 3–4 cycles) or when the female partner is over age 35, exogenous gonadotropin stimulation may be expected to improve the likelihood for success.**



# Sperm Preparation

There are a variety of methods for extracting sperms from the seminal plasma for IUI. The most common methods include conventional washing, the “swim-up” procedure, and density gradient centrifugation. The best choice among them may vary with the quality of the semen sample.<sup>525,526</sup> The results of a randomized study comparing the pregnancy rates achieved with IUI after a variety of sperm preparation methods suggest that swim-up and density gradient centrifugation may offer a greater chance for success than conventional sperm washing.<sup>525</sup> Another study found that density gradient centrifugation yielded better results than does conventional washing when the insemination specimen contains less than approximately 20 million sperms.<sup>526</sup> However, a meta-analysis including 5 trials involving over 250 couples and comparing 3 techniques concluded that evidence is insufficient to recommend any specific preparation technique.<sup>527</sup> Results achieved with IUI using cryopreserved donor sperms are comparable, regardless whether the sperms are prepared before freezing or after thawing.<sup>504</sup>

Both the conventional washing and swim-up methods allow sperms to remain in contact with dead or defective sperms and leukocytes, which produce high levels of reactive oxygen species that may cause oxidative damage to sperms membranes and motility.<sup>528,529</sup> **Whereas methods more sophisticated than conventional washing or swim-up may be used to prepare sperms (density gradient centrifugation, glass wool filtration, others), and often are used when preparing sperms for IVF,<sup>530</sup> they generally are not required for IUI.**

## Washing

The simplest method of washing sperms involves diluting the liquefied semen sample in buffered medium (available from a number of commercial suppliers) in a sterile tube (1:1–1:3, depending on volume), followed by low-speed centrifugation (200–300g for approximately 10 minutes) and removal of the supernatant. After two or more cycles, the final pellet is resuspended in a small volume (approximately 0.5 mL) of medium for insemination. Sperm washing yields the greatest numbers of sperms, but the final specimen also contains dead and abnormal sperms and other cellular debris. When sperm viability or motility is abnormally low or the round cell concentration in the semen is abnormally high, methods to exclude them from the insemination specimen deserve consideration.

## Swim-Up

The swim-up method for preparing sperms adds another step to the washing process. The final pellet is gently overlaid with 0.5–1.0 mL of fresh medium and incubated at 37°C for 30–60 minutes, allowing the most motile sperms to swim up into the supernatant.<sup>531</sup> The method generates a cleaner specimen, devoid of dead sperms and other cellular debris, but also yields significantly lower numbers of sperms (albeit with high motility) and therefore may be inadvisable when the sperm concentration is already very low.

## **Density Gradient Centrifugation**

The typical methodology for density gradient centrifugation involves overlaying the liquefied ejaculate on a column of higher-density media that are layered to create a gradient of increasing density from the top to the bottom of the column, followed by low-speed centrifugation for 15–30 minutes.<sup>532</sup> The most highly motile sperms traverse the gradient more rapidly and can be recovered from the soft pellet at the bottom. The method also appears to select a population of sperms with normal morphology.<sup>533,534</sup> As with the swim-up procedure, the sperm yield is substantially lower than with conventional washing.

## Timing and Technique

For obvious reasons and for best results, IUI should be timed to coincide with the time of spontaneous or induced ovulation. Normal sperms can survive in the female reproductive tract and retain the ability to fertilize an egg for at least 3 days, but an oocyte can be successfully fertilized for only approximately 12–24 hours after it is released.<sup>535</sup> In normal fertile couples, the probability of conception rises progressively over an interval of 5–6 days and peaks when intercourse occurs on the day before or day of ovulation.<sup>80,536,537</sup> The longevity of normal sperms in the female genital tract relates, in part, to their retention within the cervical mucus, which, of course, is bypassed by IUI. Although unproven, there is reason to believe that sperms may have a significantly shorter functional lifespan after IUI. Logically, the lower numbers and motility of infertile partner sperms may be even more limiting. Cryopreservation damages sperms,<sup>538</sup> and even frozen-thawed donor sperms lose viability and motility more rapidly than do fresh normal sperms. **The timing of IUI in the treatment of male factor infertility is therefore far more critical for success than the timing of natural intercourse in infertile couples, regardless whether infertile partner sperms or frozen donor sperms are used.**

The various methods that may be used to detect ovulation and to ensure that IUI is optimally timed are described at length elsewhere in this text ([Chapter 27](#)); only the most commonly used methods and their relationship to the time of ovulation are again briefly summarized here. Ovulation generally may be expected to occur on the day before the midcycle rise in basal body temperature (BBT)<sup>80,537</sup> or 14–26 hours after the urinary LH surge is first detected.<sup>539,540</sup> **In natural and clomiphene-stimulated cycles, the most practical and reliable method for timing IUI involves urinary LH monitoring beginning approximately 3 days before expected ovulation and insemination on the day following detection of the LH surge. When ovulation is triggered by injection of exogenous hCG in natural or stimulated cycles, IUI generally is best performed approximately 34–40 hours later.**

Immediately before performing IUI, removal of any excess mucus that might clog the catheter tip is recommended. The tip of the insemination catheter is then simply inserted into the cervical os and advanced slowly into the uterine cavity. A large variety of specialized catheters having varying rigidity is readily available from commercial sources and any may be used. Designs involving a stiffer moldable outer sheath over a more atraumatic and flexible inner catheter are the most versatile. The insemination specimen (approximately 0.5 mL) should be introduced slowly over 10–30 seconds. Although there are no data to indicate that it matters, it is customary to have the patient remain supine for approximately 10–15 minutes after insemination.

Although some have suggested that two inseminations (12 and 34 hours after hCG-induced ovulation) yield a higher cycle fecundability than a single IUI,<sup>541</sup> other similarly designed studies have found no such advantage.<sup>542,543,544</sup> A meta-analysis including 3 randomized controlled parallel trials involving nearly 400 couples concluded that available data do not allow a confident conclusion.<sup>545</sup> Two studies of cycle fecundability after therapeutic donor inseminations have observed that two inseminations are no more effective than one.<sup>546,547</sup>

Most women who pursue therapeutic donor insemination are otherwise fertile and conceive within 4–6 insemination cycles; cycle fecundability declines by half to two-thirds thereafter.<sup>515,548,549,550</sup> Cumulative conception rates after up to 12 insemination cycles reach 75–80%<sup>503,505,515</sup> but are approximately 50% lower for those having other infertility factors.<sup>513</sup> Combined with gonadotropin stimulation, donor insemination succeeds in more than half of treated couples achieving superovulation after up to three cycles.<sup>550</sup> As expected, success rates for insemination with infertile partner sperms are significantly lower but may still approach 30% after up to six treatment cycles.<sup>499</sup> The number of treatment cycles offered must consider the influence of female partner age, coexisting infertility factors, the duration of infertility, the quality of the insemination specimen, and the number of mature preovulatory follicles when ovarian stimulation also is used.

# Donor Sperms

In general, commercial and university-based sperm banks recruit healthy young donors having desirable general physical characteristics and consistently outstanding semen quality. However, it is important to understand that whereas sperm banks generally adhere to the guidelines established by the American Society for Reproductive Medicine,<sup>551</sup> they remain, at present, self-regulated. The choice of a sperm bank should therefore consider whether it has formally adopted the established guidelines.

Current guidelines require extensive screening of prospective sperm donors before acceptance. Semen quality, to include an evaluation of sperm viability and motility after a trial freeze and thaw,<sup>538,552</sup> excludes approximately 75% of all candidates. Personal health history and physical examination, family medical history, genetic screening for cystic fibrosis and other carrier states (depending on ethnicity), and screening for sexually transmitted infections (syphilis, gonorrhea, Chlamydia, cytomegalovirus, hepatitis B and C, HIV types I and II, and human T-lymphocytic virus [HTLV] types I and II), which is regulated by the Food and Drug Administration (FDA) in the United States, exclude another 5–10% of candidates. Sperm donors must be screened repeatedly for sexually transmitted infections at intervals, generally every 6 months. Sperm banking practices changed forever in 1985 after documentation of HIV seroconversion in four of eight women inseminated with cryopreserved sperms from an asymptomatic HIV (then called HTLV-III) carrier.<sup>553</sup> **Now, sperm specimens must be quarantined and cannot be released for use unless they have remained sequestered for at least the 180 days preceding the most recent negative test for HIV.** Even with rigorous adherence to current guidelines, human semen can never be regarded as completely safe. Although perhaps remote, the possibility remains that frozen donor sperm specimens may contain other microorganisms not generally considered as sexually transmitted infections or as yet unknown viruses.

Ideally, donor-specific cycle fecundability rates, which may vary significantly, also would be defined after a reasonable number of inseminations.<sup>552,554</sup> However, such information generally is not available, primarily because outcomes of donor inseminations are difficult to track accurately and vary substantially among recipients, depending on age and the presence or absence of other infertility factors. In the absence of such information, it is reasonable to select an alternative donor after four to six unsuccessful insemination cycles when there are no other coexisting infertility factors.

**Although the quality of frozen donor sperm specimens generally is reliable, it should not be assumed.** Frozen donor sperm specimens typically do not include all of the sperms in an ejaculate; a number of aliquots are prepared from each sample, depending on its quality. One study found a tenfold variation in the number of motile

sperms in random specimens obtained from seven different commercial sperm banks (4.3–39 million).<sup>555</sup> As when using infertile partner sperms, the likelihood of success with therapeutic donor insemination increases with the number of motile sperms in the specimen and is greatest when the count exceeds 20 million.<sup>515</sup> Most sperm banks guarantee a minimum number of motile sperms in each specimen, but that guarantee is not always met and only implies a refund of the purchase price when it is not. Consequently, it is prudent to determine the motile sperm count after thaw of donor sperm samples and to seek an alternative source when quality consistently falls below a reasonable minimum standard (10 million total motile sperms).

# SURGICAL TREATMENT FOR MALE INFERTILITY

---

Although IVF with ICSI now provides the means to treat even the most severe forms of male factor infertility, including irreparable reproductive tract obstruction and nonobstructive azoospermia, the associated costs and risks are substantial. For men with obstructive azoospermia or a varicocele, specific surgical treatment offers a viable alternative, but proper patient selection is key.<sup>556,557,558,559</sup>

# Vasovasostomy and Vasoepididymostomy

**About one-half million American men undergo vasectomy every year and approximately 2–6% of vasectomized men later seek reversal of their sterilization procedure.** Obstructive azoospermia also may result from iatrogenic injuries to the vas deferens, usually during hernia repair.<sup>284</sup>

In most vasectomized men, microsurgical vasovasostomy or vasoepididymostomy can restore patency of the ductal system and return sperms to the ejaculate. When microscopic examination of the fluid in the testicular end of the vas reveals no sperms even after lavage, vasoepididymostomy can be performed.<sup>560</sup> When sperms are found in the vasal fluid on at least one side, microsurgical vasovasostomy returns sperms to the ejaculate in nearly all vasectomized men<sup>561</sup>; late obstruction after initial patency may be observed in up to 12% of men.<sup>562</sup> **Over 2 years or more after vasovasostomy, pregnancy rates in the range of 50–60% may be expected, depending on whether other infertility factors also must be overcome.**<sup>563</sup> The likelihood of pregnancy decreases modestly with time since vasectomy, but not dramatically; for most, surgery offers comparable or better results than can be achieved with IVF and ICSI.<sup>564,565</sup> The results of reoperation may approach the same outcomes when the first attempt is technically unsuccessful.<sup>566</sup> Compared to vasovasostomy, vasoepididymostomy is less often successful, with patency rates between 50% and 85%, pregnancy rates between 40% and 50%, and a greater likelihood of reocclusion, depending on the site of anastomosis.<sup>556,567</sup> Newly described tubal intussusception techniques have simplified the procedure and yielded excellent patency rates.<sup>568,569</sup> Cryopreservation of sperms collected at the time of vasectomy reversal offers those with failed procedures the opportunity to pursue pregnancy by IVF and ICSI without further intervention.<sup>567,570</sup>



# Transurethral Resection of the Ejaculatory Ducts

Ejaculatory duct obstruction is a cause of infertility in 1–5% of infertile men<sup>571</sup> and should be suspected in men with normal, palpable vasa deferentia and semen analyses revealing low ejaculate volumes combined with low or normal sperm concentration and low or absent motility.<sup>572</sup> The condition also may present as hemospermia and painful ejaculation. Ejaculatory duct obstruction usually is congenital but also can result from chronic prostatitis or compression by prostate or seminal vesicle duct cysts and from duct calcification or blockage due to postinfectious or postoperative scar and may be amenable to correction by transurethral resection.<sup>573,574</sup>

Methods for evaluating suspected ejaculatory duct obstruction include transscrotal vasography (antegrade or retrograde injection of contrast medium into the vas deferens or seminal vesicle), transrectal ultrasonography (to detect an enlarged seminal vesicle), and seminal vesicle sperm aspiration and ejaculatory duct chromotubation. A study comparing the accuracy of the methods found that diagnosis by transrectal ultrasonography was confirmed at surgery in fewer than half of cases and concluded that dynamic tests (vasography, chromotubation) can decrease unnecessary duct resection procedures and improve the outcomes of those that are indicated.<sup>575</sup>

Transrectal ultrasound-guided aspiration of cystic or dilated ejaculatory ducts or seminal vesicles and microscopic examination of the aspirate may yield sperms that can be cryopreserved.<sup>430</sup> Subsequent introduction of indigo carmine dye diluted in radiographic contrast and x-ray provides the means to define the lesion and to confirm successful surgical resection. When no sperms are found, vasography may be performed, and if ejaculatory duct obstruction is confirmed, a coincident epididymal obstruction is likely. Under such circumstances, microsurgical epididymal sperm aspiration or testis biopsy and cryopreservation of sperm for IVF and ICSI generally is a better option than simultaneous epididymovasostomy and transurethral resection of the ejaculatory ducts.

**Transurethral resection of an ejaculatory duct obstruction results in increased semen volume in approximately two-thirds of affected men and returns sperms to the ejaculate in about half of azoospermic men.** Results are better in men with midline cysts and men with partial obstruction than in those with complete obstructions. Whereas IVF and ICSI are obvious alternatives to transurethral resection, successful surgery can allow many men to conceive naturally or by IUI without need for ART.<sup>576</sup>

# Varicocele Repair

The prevalence of varicoceles is approximately 10–15% in the normal male population and about 25–40% in infertile men.<sup>307,427</sup> The weight of available evidence indicates that varicoceles have an adverse effect on spermatogenesis. The pathophysiology involved is unclear but widely believed to involve venous reflux and increased testicular temperatures because spermatogenesis is exquisitely temperature sensitive. **Since only palpable varicoceles have any documented association with infertility, other means of diagnosis (scrotal ultrasonography, thermography, Doppler ultrasonography, radionuclide scanning, and spermatic venography) generally are not indicated for infertile men with no palpable varicocele.** Scrotal ultrasonography may be useful when physical examination is inconclusive and spermatic venography can help to better define the location of refluxing spermatic veins that recur or persist after repair.<sup>307</sup>

**Varicocele repair is considered primarily for men with palpable varicoceles and abnormal semen parameters having either a partner with normal fertility or treatable infertility or an interest in future fertility.** Adolescent males with unilateral or bilateral varicoceles associated with decreased testicular size also may be candidates for varicocelectomy; those with normal testicular size should be followed carefully to detect any decrease in testicular size or semen quality.<sup>577,578</sup> Similarly, young adult men with palpable varicoceles and normal semen may be at risk for progressive testicular dysfunction and should be monitored to detect any evidence of decreasing semen quality.<sup>426,579,580</sup>

**Treatment options for men with abnormal semen quality associated with a palpable varicocele include surgical repair, IUI, and IVF with or without ICSI. The best choice among these options depends on the age of the female partner and presence of other infertility factors.** Varicocelectomy offers the potential advantages of a permanent cure and natural conception.<sup>558</sup> Even when there are other clear female partner indications for IVF, varicocele repair may deserve consideration because surgery can restore sperms to the ejaculate in some men with nonobstructive azoospermia.<sup>581,582</sup>

Varicoceles can be repaired with a variety of surgical approaches (retroperitoneal, inguinal, subinguinal, laparoscopic) or by percutaneous embolization. No one method has proven clearly superior. Most male reproductive specialists prefer microsurgical inguinal or subinguinal repair.<sup>583</sup> Percutaneous embolization of varicoceles requires expertise in interventional radiologic techniques and is not universally applicable. Surgical treatment corrects over 90% of varicoceles; results achieved with

embolization are more variable.

Semen quality often improves after varicocele repair<sup>584</sup> and men with large varicoceles generally realize the greatest improvement.<sup>585</sup> **However, the results achieved with varicocele repair have varied widely and convincing evidence for improved fertility is still lacking.**<sup>558,586,587,588</sup> The results of two randomized trials in men with palpable varicoceles, abnormal semen parameters, and normal female partners are perhaps the most informative. In one, 60% of men who underwent surgical repair achieved pregnancy with their partner during the first postoperative year, compared to only 10% of untreated controls; after surgical repair of varicoceles in the still infertile men not initially treated, more than 40% achieved pregnancy during the following year.<sup>589</sup> In the second trial, men who underwent varicocele repair had improved semen parameters compared to untreated controls but were no more likely to achieve pregnancy.<sup>590</sup> **In general, the best candidates for varicocele repair are young men with large varicoceles and infertility of relatively short duration. Atrophic testes, elevated FSH levels, and severe oligospermia or azoospermia indicate severe epithelial damage and are associated with a poor prognosis after varicocele repair.**

One other potential benefit of varicocelectomy deserves mention. Even when varicocele repair is not followed by natural conception, improvement in semen parameters may be sufficient to allow IUI when IVF would otherwise be necessary, or IVF with conventional fertilization rather than with ICSI.<sup>591</sup>

# Orchiopexy

Cryptorchidism is associated with a high incidence of infertility even when it is unilateral; when both testes are undescended, azoospermia is all but certain. Occasionally, an undescended testis will escape detection until adulthood; if the contralateral testis is normal, fertility may be preserved. Even in adult men with bilateral cryptorchidism, orchiopexy can result in spermatogenesis and fertility; at the least, it preserves testicular hormone production.<sup>592</sup>

# **Vibratory Stimulation and Electroejaculation**

Men with neurologic conditions affecting the sympathetic system frequently have dysfunctional or absent emission. Examples include men with spinal cord injuries, demyelinating neuropathies, and diabetes and those who have had retroperitoneal lymph node dissections. In most, ejaculation can be achieved with vibratory stimulation, and in those who don't respond, electroejaculation can be used to obtain motile sperms for IUI or IVF and ICSI.<sup>479,593</sup> Because ejaculation may be retrograde, additional techniques for recovery of sperms from the bladder may be required (described above).

# ASSISTED TECHNOLOGIES

# REPRODUCTIVE

---

IVF and ICSI have revolutionized the treatment of male infertility. As it was originally performed, IVF involved insemination of each oocyte with 2–6 million sperms; consequently, the method had only limited application when the male was severely oligospermic. With refinements in technique over time, the number of motile sperms used for insemination decreased to 50–100 thousand per oocyte, opening the door to wider application of ART in couples with male factor infertility. The advent of ICSI further expanded capabilities to overcome even the most severe forms of male infertility.<sup>594,595</sup> Now, a male factor is the single one most common diagnosis among couples who undergo IVF. In the US national summary of ART success rates for the year 2015, 35% of all cycles were performed for male factor indications, and a male factor was one of multiple infertility factors in another 18% of cycles.<sup>596</sup> In 2015, ICSI was performed for over 90% of cycles involving fresh nondonor oocytes with an indication of male infertility.<sup>596</sup> In the same year, ICSI was used for over 70% of all cycles using fresh nondonor oocytes without a male factor.<sup>596</sup> **Overall, the results achieved with IVF in couples with male factor infertility, with and without ICSI, are comparable to those observed in couples with other indications for IVF.**<sup>596</sup>

# Sperm Retrieval

Although ICSI is now applied rather liberally in IVF cycles, even in couples without male factor infertility, it is most specifically indicated in couples with severe male factor infertility where poor or failed fertilization is more likely. When few or no viable sperms can be recovered from the ejaculate, a variety of sperm retrieval techniques may be used to obtain sperms for IVF and ICSI. Even when substantial numbers of sperms are retrieved, ICSI is prudent because sperms obtained from chronically obstructed reproductive systems usually exhibit poor motility and decreased fertilizing capacity.

# Epididymal Sperm Aspiration

Sperms may be obtained by microsurgical epididymal sperm aspiration at the time of vasopididymostomy or as an isolated procedure in men with CBAVD or uncorrectable obstructions. The technique involves incision of an isolated dilated tubule, gradually moving more proximally, if necessary, until sperms are obtained.<sup>597,598</sup> Sperms are collected into a micropipette by capillary action with gentle compression of the testis and epididymis and flushed into a container with a small volume of IVF culture medium. Recovered sperms are cryopreserved in multiple aliquots for use in IVF cycles, if required.<sup>599</sup>

Percutaneous epididymal sperm aspiration (PESA) using a fine needle has also been used successfully to obtain sperms and achieve pregnancy,<sup>600,601</sup> but the technique is less reliable, the small quantities of sperms obtained are sometimes inadequate to allow cryopreservation, and pregnancy rates achieved have generally been lower than with the open technique.



# Testicular Sperm Extraction and Aspiration (TESE and TESA)

In men with nonobstructive azoospermia and those in whom epididymal sperm aspiration techniques fail or are inapplicable, sperms may be retrieved directly from the testis.<sup>602,603</sup> Open microsurgical testicular sperm extraction yields the greatest number of sperms with potential for cryopreservation. Percutaneous core biopsy and aspiration of the testis have also been described and are most applicable in men with normal spermatogenesis and obstructive azoospermia.<sup>604</sup>

Using the preferred open microsurgical technique, sperms can be retrieved from the majority of men. Magnification minimizes the risk of injury to the testicular blood supply, increases the probability of retrieving a blood-free biopsy specimen, and allows identification of larger caliber tubules that are more likely to yield sperms.<sup>605,606</sup> Normal pregnancies have been achieved even in those with congenital or acquired testicular failure,<sup>607,608,609</sup> postchemotherapy azoospermia,<sup>610,611,612</sup> and Klinefelter syndrome.<sup>440,613</sup>

# GENETIC RISKS ASSOCIATED WITH ICSI

---

Because ICSI may override natural safeguards that serve to prevent fertilization by sperms with abnormal or damaged DNA, there is reason for concern that children born after ICSI might be at increased risk for chromosomal and other major congenital anomalies,<sup>94,614,615</sup> cancers,<sup>616,617,618</sup> or infertility.<sup>449,450,451,616</sup> Most studies,<sup>619,620,621,622</sup> but not all,<sup>614</sup> have failed to identify any increased incidence of major congenital malformation among children born after ICSI (beyond that associated with conventional IVF),<sup>622,623</sup> perhaps, at least in part, because embryos derived from damaged paternal DNA are less likely to implant and naturally select out.<sup>410,418</sup> One specific malformation that may be more prevalent in children born after ICSI is hypospadias, possibly due to paternal infertility.<sup>624</sup> **Regardless, karyotyping and Y chromosome deletion analysis should be offered to all men with severe male factor infertility who are candidates for IVF with ICSI, and additional studies are clearly needed to determine what if any increased risks might be imposed on children born after ICSI.**<sup>625</sup>

# REFERENCES

1. **Thonneau P, Marchand S, Tallec A, Ferial ML, Ducot B, Lansac J, Lopes P, Tabaste JM, Spira A**, Incidence and main causes of infertility in a resident population (1,850,000) of three French regions (1988–1989), *Hum Reprod* 6:811, 1991.
2. **Wong CH, Cheng CY**, The blood-testis barrier: its biology, regulation, and physiological role in spermatogenesis, *Curr Top Dev Biol* 71:263, 2005.
3. **Vogel F, Rathenberg R**, Spontaneous mutation in man, *Adv Hum Genet* 5:223, 1975.
4. **Buaas FW, Kirsh AL, Sharma M, McLean DJ, Morris JL, Griswold MD, de Rooij DG, Braun RE**, Plzf is required in adult male germ cells for stem cell self-renewal, *Nat Genet* 36:647, 2004.
5. **Costoya JA, Hobbs RM, Barna M, Cattoretti G, Manova K, Sukhwani M, Orwig KE, Wolgemuth DJ, Pandolfi PP**, Essential role of Plzf in maintenance of spermatogonial stem cells, *Nat Genet* 36:653, 2004.
6. **Johnson L, Petty CS, Neaves WB**, Further quantification of human spermatogenesis: germ cell loss during postprophase of meiosis and its relationship to daily sperm production, *Biol Reprod* 29:207, 1983.
7. **Lie PP, Cheng CY, Mruk DD**, Coordinating cellular events during spermatogenesis: a biochemical model, *Trends Biochem Sci* 34:366, 2009.
8. **Burgoyne PS**, The role of the mammalian Y chromosome in spermatogenesis, *Development* 101(Suppl):133, 1987.
9. **Heller CG, Clermont Y**, Spermatogenesis in man: an estimate of its duration, *Science* 140:184, 1963.
10. **Rowley MJ, Teshima F, Heller CG**, Duration of transit of spermatozoa through the human male ductular system, *Fertil Steril* 21:390, 1970.
11. **Hinrichsen MJ, Blaquier JA**, Evidence supporting the existence of sperm maturation in the human epididymis, *J Reprod Fertil* 60:291, 1980.
12. **Wang C, McDonald V, Leung A, Superlano L, Berman N, Hull L, Swerdloff RS**, Effect of increased scrotal temperature on sperm production in normal men, *Fertil Steril* 68:334, 1997.
13. **Ketelslegers JM, Hetzel WD, Sherins RJ, Catt KJ**, Developmental changes in testicular gonadotropin receptors: plasma gonadotropins and plasma testosterone in the rat, *Endocrinology* 103:212, 1978.
14. **Wahlstrom T, Huhtaniemi I, Hovatta O, Seppala M**, Localization of luteinizing hormone, follicle-stimulating hormone, prolactin, and their receptors in human and rat testis using immunohistochemistry and radioreceptor assay, *J Clin Endocrinol Metab* 57:825, 1983.
15. **Morse HC, Horike N, Rowley MJ, Heller CG**, Testosterone concentrations in testes of normal men: effects of testosterone propionate administration, *J Clin Endocrinol Metab* 37:882, 1973.
16. **McLachlan RI, O'Donnell L, Meachem SJ, Stanton PG, de K, Pratis K, Robertson DM**, Hormonal regulation of spermatogenesis in primates and man: insights for development of the male hormonal contraceptive, *J Androl* 23:149, 2002.
17. **Matsumoto AM, Bremner WJ**, Modulation of pulsatile gonadotropin secretion by testosterone in man, *J Clin Endocrinol Metab* 58:609, 1984.
18. **Plant TM, Dubey AK**, Evidence from the rhesus monkey (*Macaca mulatta*) for the view that negative feedback control of luteinizing hormone secretion by the testis is mediated by a deceleration of hypothalamic gonadotropin-releasing hormone pulse frequency, *Endocrinology* 115:2145, 1984.
19. **Veldhuis JD, Rogol AD, Samojlik E, Ertel NH**, Role of endogenous opiates in the expression of negative feedback actions of androgen and estrogen on pulsatile properties of luteinizing hormone secretion in man, *J Clin Invest* 74:47, 1984.
20. **Sheckter CB, Matsumoto AM, Bremner WJ**, Testosterone administration inhibits gonadotropin secretion by an effect directly on the human pituitary, *J Clin Endocrinol Metab* 68:397, 1989.
21. **Santen RJ**, Is aromatization of testosterone to estradiol required for inhibition of luteinizing hormone secretion in men? *J Clin Invest* 56:1555, 1975.
22. **Winters SJ, Troen P**, Evidence for a role of endogenous estrogen in the hypothalamic control of gonadotropin secretion in men, *J Clin Endocrinol Metab* 61:842, 1985.

23. **Lacroix A, McKenna TJ, Rabinowitz D**, Sex steroid modulation of gonadotropins in normal men and in androgen insensitivity syndrome, *J Clin Endocrinol Metab* 48:235, 1979.
24. **Bagatell CJ, Dahl KD, Bremner WJ**, The direct pituitary effect of testosterone to inhibit gonadotropin secretion in men is partially mediated by aromatization to estradiol, *J Androl* 15:15, 1994.
25. **Morishima A, Grumbach MM, Simpson ER, Fisher C, Qin K**, Aromatase deficiency in male and female siblings caused by a novel mutation and the physiological role of estrogens, *J Clin Endocrinol Metab* 80:3689, 1995.
26. **Hayes FJ, Seminara SB, Decruz S, Boepple PA, Crowley WF Jr**, Aromatase inhibition in the human male reveals a hypothalamic site of estrogen feedback, *J Clin Endocrinol Metab* 85:3027, 2000.
27. **Plymate SR, Paulsen CA, McLachlan RI**, Relationship of serum inhibin levels to serum follicle stimulating hormone and sperm production in normal men and men with varicoceles, *J Clin Endocrinol Metab* 74:859, 1992.
28. **Anderson RA, Wallace EM, Groome NP, Bellis AJ, Wu FC**, Physiological relationships between inhibin B, follicle stimulating hormone secretion and spermatogenesis in normal men and response to gonadotrophin suppression by exogenous testosterone, *Hum Reprod* 12:746, 1997.
29. **Illingworth PJ, Groome NP, Byrd W, Rainey WE, McNeilly AS, Mather JP, Bremner WJ**, Inhibin-B: a likely candidate for the physiologically important form of inhibin in men, *J Clin Endocrinol Metab* 81:1321, 1996.
30. **Majumdar SS, Mikuma N, Ishwad PC, Winters SJ, Attardi BJ, Perera AD, Plant TM**, Replacement with recombinant human inhibin immediately after orchidectomy in the hypophysiotropically clamped male rhesus monkey (*Macaca mulatta*) maintains follicle-stimulating hormone (FSH) secretion and FSH beta messenger ribonucleic acid levels at precastration values, *Endocrinology* 136:1969, 1995.
31. **Ramaswamy S, Marshall GR, Pohl CR, Friedman RL, Plant TM**, Inhibitory and stimulatory regulation of testicular inhibin B secretion by luteinizing hormone and follicle-stimulating hormone, respectively, in the rhesus monkey (*Macaca mulatta*), *Endocrinology* 144:1175, 2003.
32. **Saez JM**, Leydig cells: endocrine, paracrine, and autocrine regulation, *Endocr Rev* 15:574, 1994.
33. **Gnessi L, Fabbri A, Spera G**, Gonadal peptides as mediators of development and functional control of the testis: an integrated system with hormones and local environment, *Endocr Rev* 18:541, 1997.
34. **Nieschlag E, Simoni M, Gromoll J, Weinbauer GF**, Role of FSH in the regulation of spermatogenesis: clinical aspects, *Clin Endocrinol (Oxf)* 51:139, 1999.
35. **Huleihel M, Abuelhija M, Lunenfeld E**, In vitro culture of testicular germ cells: regulatory factors and limitations, *Growth Factors* 25:236, 2007.
36. **Sofikitis N, Giotitsas N, Tsounapi P, Baltogiannis D, Giannakis D, Pardalidis N**, Hormonal regulation of spermatogenesis and spermiogenesis, *J Steroid Biochem Mol Biol* 109:323, 2008.
37. **Weiss J, Axelrod L, Whitcomb RW, Harris PE, Crowley WF, Jameson JL**, Hypogonadism caused by a single amino acid substitution in the beta subunit of luteinizing hormone, *N Engl J Med* 326:179, 1992.
38. **Levalle O, Zylbersztejn C, Aszpis S, Aquilano D, Terradas C, Colombani M, Aranda C, Scaglia H**, Recombinant human follicle-stimulating hormone administration increases testosterone production in men, possibly by a Sertoli cell-secreted nonsteroid factor, *J Clin Endocrinol Metab* 83:3973, 1998.
39. **Tapanainen JS, Aittomäki K, Min J, Vaskivuo T, Huhtaniemi I**, Men homozygous for an inactivating mutation of the follicle-stimulating hormone (FSH) receptor gene present variable suppression of spermatogenesis and fertility, *Nat Genet* 15:205, 1997.
40. **Mozaffarian GA, Higley M, Paulsen CA**, Clinical studies in an adult male patient with "isolated follicle stimulating hormone (FSH) deficiency", *J Androl* 4:393, 1983.
41. **Al-Ansari AA, Khalil TH, Kelani Y, Mortimer CH**, Isolated follicle-stimulating hormone deficiency in men: successful long-term gonadotropin therapy, *Fertil Steril* 42:618, 1984.
42. **Marshall GR, Wickings EJ, Nieschlag E**, Testosterone can initiate spermatogenesis in an immature nonhuman primate, *Macaca fascicularis*, *Endocrinology* 114:2228, 1984.
43. **Phillip M, Arbelle JE, Segev Y, Parvari R**, Male hypogonadism due to a mutation in the gene for the beta-subunit of follicle-stimulating hormone, *N Engl J Med* 338:1729, 1998.
44. **Lindstedt G, Nystrom E, Matthews C, Ernest I, Janson PO, Chatterjee K**, Follitropin (FSH) deficiency in an infertile male due to FSH beta gene mutation. A syndrome of normal puberty and virilization but

underdeveloped testicles with azoospermia, low FSH but high luteinizing hormone and normal serum testosterone concentrations, *Clin Chem Lab Med* 36:663, 1998.

45. **Finkel DM, Phillips JL, Snyder PJ**, Stimulation of spermatogenesis by gonadotropins in men with hypogonadotropic hypogonadism, *N Engl J Med* 313:651, 1985.
46. **Weinbauer GF, Behre HM, Fingscheidt U, Nieschlag E**, Human follicle-stimulating hormone exerts a stimulatory effect on spermatogenesis, testicular size, and serum inhibin levels in the gonadotropin-releasing hormone antagonist-treated nonhuman primate (*Macaca fascicularis*), *Endocrinology* 129:1831, 1991.
47. **Weinbauer GF, Schlatt S, Walter V, Nieschlag E**, Testosterone-induced inhibition of spermatogenesis is more closely related to suppression of FSH than to testicular androgen levels in the cynomolgus monkey model (*Macaca fascicularis*), *J Endocrinol* 168:25, 2001.
48. **Simoni M, Gromoll J, Nieschlag E**, The follicle-stimulating hormone receptor: biochemistry, molecular biology, physiology, and pathophysiology, *Endocr Rev* 18:739, 1997.
49. **Gromoll J, Simoni M, Nieschlag E**, An activating mutation of the follicle-stimulating hormone receptor autonomously sustains spermatogenesis in a hypophysectomized man, *J Clin Endocrinol Metab* 81:1367, 1996.
50. **Vicari E, Mongioi A, Calogero AE, Moncada ML, Sidoti G, Polosa P, D'Agata R**, Therapy with human chorionic gonadotrophin alone induces spermatogenesis in men with isolated hypogonadotropic hypogonadism—long-term follow-up, *Int J Androl* 15:320, 1992.
51. **Srinath BR, Wickings EJ, Witting C, Nieschlag E**, Active immunization with follicle-stimulating hormone for fertility control: a 4 1/2-year study in male rhesus monkeys, *Fertil Steril* 40:110, 1983.
52. **Moudgal NR, Ravindranath N, Murthy GS, Dighe RR, Aravindan GR, Martin F**, Long-term contraceptive efficacy of vaccine of ovine follicle-stimulating hormone in male bonnet monkeys (*Macaca radiata*), *J Reprod Fertil* 96:91, 1992.
53. **Moudgal NR, Sairam MR**, Is there a true requirement for follicle stimulating hormone in promoting spermatogenesis and fertility in primates? *Hum Reprod* 13:916, 1998.
54. **Moudgal NR, Murthy GS, Prasanna Kumar KM, Martin F, Suresh R, Medhamurthy R, Patil S, Sehgal S, Saxena BN**, Responsiveness of human male volunteers to immunization with ovine follicle stimulating hormone vaccine: results of a pilot study, *Hum Reprod* 12:457, 1997.
55. **Matsumoto AM, Karpas AE, Bremner WJ**, Chronic human chorionic gonadotropin administration in normal men: evidence that follicle-stimulating hormone is necessary for the maintenance of quantitatively normal spermatogenesis in man, *J Clin Endocrinol Metab* 62:1184, 1986.
56. **Behre HM, Baus S, Kliesch S, Keck C, Simoni M, Nieschlag E**, Potential of testosterone buciclate for male contraception: endocrine differences between responders and nonresponders, *J Clin Endocrinol Metab* 80:2394, 1995.
57. **Buchter D, von Eckardstein S, von Eckardstein A, Kamischke A, Simoni M, Behre HM, Nieschlag E**, Clinical trial of transdermal testosterone and oral levonorgestrel for male contraception, *J Clin Endocrinol Metab* 84:1244, 1999.
58. **Arslan M, Weinbauer GF, Schlatt S, Shahab M, Nieschlag E**, FSH and testosterone, alone or in combination, initiate testicular growth and increase the number of spermatogonia and Sertoli cells in a juvenile non-human primate (*Macaca mulatta*), *J Endocrinol* 136:235, 1993.
59. **Schlatt S, Arslan M, Weinbauer GF, Behre HM, Nieschlag E**, Endocrine control of testicular somatic and premeiotic germ cell development in the immature testis of the primate *Macaca mulatta*, *Eur J Endocrinol* 133:235, 1995.
60. **Whitcomb RW, Crowley WF Jr**, Clinical review 4: Diagnosis and treatment of isolated gonadotropin-releasing hormone deficiency in men, *J Clin Endocrinol Metab* 70:3, 1990.
61. **Burgues S, Calderon MD**, Subcutaneous self-administration of highly purified follicle stimulating hormone and human chorionic gonadotrophin for the treatment of male hypogonadotropic hypogonadism. Spanish Collaborative Group on Male Hypogonadotropic Hypogonadism, *Hum Reprod* 12:980, 1997.
62. **Buchter D, Behre HM, Kliesch S, Nieschlag E**, Pulsatile GnRH or human chorionic gonadotropin/human menopausal gonadotropin as effective treatment for men with hypogonadotropic hypogonadism: a review of 42 cases, *Eur J Endocrinol* 139:298, 1998.

63. **Schaison G, Young J, Pholsena M, Nahoul K, Couzinet B**, Failure of combined follicle-stimulating hormone-testosterone administration to initiate and/or maintain spermatogenesis in men with hypogonadotropic hypogonadism, *J Clin Endocrinol Metab* 77:1545, 1993.
64. **Ventura SJ, Martin JA, Curtin SC, Matthew MS**, Report of final natality statistics, 1995, *Mon Vital Stat Rep* 45(Suppl 11), 1997.
65. **Ventura SJ, Hamilton BE, Sutton PD**, Revised birth and fertility rates for the United States, 2000 and 2001, *Natl Vital Stat Rep* 51:1, 2003.
66. **Kidd SA, Eskenazi B, Wyrobek AJ**, Effects of male age on semen quality and fertility: a review of the literature, *Fertil Steril* 75:237, 2001.
67. **Eskenazi B, Wyrobek AJ, Slotter E, Kidd SA, Moore L, Young S, Moore D**, The association of age and semen quality in healthy men, *Hum Reprod* 18:447, 2003.
68. **Nankin HR**, Fertility in aging men, *Maturitas* 7:259, 1985.
69. **Bujan L, Mieusset R, Mondinat C, Mansat A, Pontonnier F**, Sperm morphology in fertile men and its age related variation, *Andrologia* 20:121, 1988.
70. **Rolf C, Behre HM, Nieschlag E**, Reproductive parameters of older compared to younger men of infertile couples, *Int J Androl* 19:135, 1996.
71. **Chia SE, Lim ST, Tay SK**, Factors associated with male infertility: a case-control study of 218 infertile and 240 fertile men, *Br J Obstet Gynaecol* 107:55, 2000.
72. **Tennekoon KH, Karunanayake EH**, Serum FSH, LH, and testosterone concentrations in presumably fertile men: effect of age, *Int J Fertil* 38:108, 1993.
73. **Vermeulen A, Kaufman JM**, Ageing of the hypothalamo-pituitary-testicular axis in men, *Horm Res* 43:25, 1995.
74. **Paulson RJ, Milligan RC, Sokol RZ**, The lack of influence of age on male fertility, *Am J Obstet Gynecol* 184:818, 2001.
75. **Hassan MA, Killick SR**, Effect of male age on fertility: evidence for the decline in male fertility with increasing age, *Fertil Steril* 79(Suppl 3):1520, 2003.
76. **ESHRE Capri workshop group**, Social determinants of human reproduction, *Hum Reprod* 16:1518, 2001.
77. **Ford WC, North K, Taylor H, Farrow A, Hull MG, Golding J**, Increasing paternal age is associated with delayed conception in a large population of fertile couples: evidence for declining fecundity in older men. The ALSPAC Study Team (Avon Longitudinal Study of Pregnancy and Childhood), *Hum Reprod* 15:1703, 2000.
78. **Dunson DB, Colombo B, Baird DD**, Changes with age in the level and duration of fertility in the menstrual cycle, *Hum Reprod* 17:1399, 2002.
79. **Klonoff-Cohen HS, Natarajan L**, The effect of advancing paternal age on pregnancy and live birth rates in couples undergoing in vitro fertilization or gamete intrafallopian transfer, *Am J Obstet Gynecol* 191:507, 2004.
80. **de La Rochebrochard E, de Mouzon J, Thepot F, Thonneau P**, Fathers over 40 and increased failure to conceive: the lessons of in vitro fertilization in France, *Fertil Steril* 85:1420, 2006.
81. **de La Rochebrochard E, Thonneau P**, Paternal age  $\geq 40$  years: an important risk factor for infertility, *Am J Obstet Gynecol* 189:901, 2003.
82. **Faber BM, Mercan R, Hamacher P, Muasher SJ, Toner JP**, The impact of an egg donor's age and her prior fertility on recipient pregnancy outcome, *Fertil Steril* 68:370, 1997.
83. **Gallardo E, Simon C, Levy M, Guanes PP, Remohi J, Pellicer A**, Effect of age on sperm fertility potential: oocyte donation as a model, *Fertil Steril* 66:260, 1996.
84. **Bellver J, Garrido N, Remohi J, Pellicer A, Meseguer M**, Influence of paternal age on assisted reproduction outcome, *Reprod Biomed Online* 17:595, 2008.
85. **Frattarelli JL, Miller KA, Miller BT, Elkind-Hirsch K, Scott RT Jr**, Male age negatively impacts embryo development and reproductive outcome in donor oocyte assisted reproductive technology cycles, *Fertil Steril* 90:97, 2008.
86. **Luna M, Finkler E, Barritt J, Bar-Chama N, Sandler B, Copperman AB, Grunfeld L**, Paternal age and assisted reproductive technology outcome in ovum recipients, *Fertil Steril* 92:1772, 2009.
87. **Hermann M, Untergasser G, Rumpold H, Berger P**, Aging of the male reproductive system, *Exp Gerontol*

35:1267, 2000.

88. **Bishop MW**, Ageing and reproduction in the male, *J Reprod Fertil* 12 (Suppl):65, 1970.
89. **Johnson L**, Spermatogenesis and aging in the human, *J Androl* 7:331, 1986.
90. **Zumoff B, Strain GW, Kream J, O'Connor J, Rosenfeld RS, Levin J, Fukushima DK**, Age variation of the 24-hour mean plasma concentrations of androgens, estrogens, and gonadotropins in normal adult men, *J Clin Endocrinol Metab* 54:534, 1982.
91. **Veldhuis JD**, Recent insights into neuroendocrine mechanisms of aging of the human male hypothalamic-pituitary-gonadal axis, *J Androl* 20:1, 1999.
92. **Goldman N, Montgomery M**, Fecundability and husband's age, *Soc Biol* 36:146, 1989.
93. **Martin RH, Spriggs E, Ko E, Rademaker AW**, The relationship between paternal age, sex ratios, and aneuploidy frequencies in human sperm, as assessed by multicolor FISH, *Am J Hum Genet* 57:1395, 1995.
94. **Egozcue J, Blanco J, Anton E, Egozcue S, Sarrate Z, Vidal F**, Genetic analysis of sperm and implications of severe male infertility—a review, *Placenta* 24(Suppl 2):S62, 2003.
95. **McInnes B, Rademaker A, Martin R**, Donor age and the frequency of disomy for chromosomes 1, 13, 21 and structural abnormalities in human spermatozoa using multicolour fluorescence in-situ hybridization, *Hum Reprod* 13:2489, 1998.
96. **Sartorelli EM, Mazzucatto LF, de Pina-Neto JM**, Effect of paternal age on human sperm chromosomes, *Fertil Steril* 76:1119, 2001.
97. **Bosch M, Rajmil O, Egozcue J, Templado C**, Linear increase of structural and numerical chromosome 9 abnormalities in human sperm regarding age, *Eur J Hum Genet* 11:754, 2003.
98. **Singh NP, Muller CH, Berger RE**, Effects of age on DNA double-strand breaks and apoptosis in human sperm, *Fertil Steril* 80:1420, 2003.
99. **Glaser RL, Broman KW, Schulman RL, Eskenazi B, Wyrobek AJ, Jabs EW**, The paternal-age effect in Apert syndrome is due, in part, to the increased frequency of mutations in sperm, *Am J Hum Genet* 73:939, 2003.
100. **Slama R, Werwatz A, Boutou O, Ducot B, Spira A, Hardle W**, Does male age affect the risk of spontaneous abortion? An approach using semiparametric regression, *Am J Epidemiol* 157:815, 2003.
101. **McIntosh GC, Olshan AF, Baird PA**, Paternal age and the risk of birth defects in offspring, *Epidemiology* 6:282, 1995.
102. **Olshan AF, Schnitzer PG, Baird PA**, Paternal age and the risk of congenital heart defects, *Teratology* 50:80, 1994.
103. **Olson JM, Breslow NE, Beckwith JB**, Wilms' tumour and parental age: a report from the National Wilms' Tumour Study, *Br J Cancer* 67:813, 1993.
104. **Zhu JL, Madsen KM, Vestergaard M, Olesen AV, Basso O, Olsen J**, Paternal age and congenital malformations, *Hum Reprod* 20:3173, 2005.
105. **Lian ZH, Zack MM, Erickson JD**, Paternal age and the occurrence of birth defects, *Am J Hum Genet* 39:648, 1986.
106. **Yang Q, Wen SW, Leader A, Chen XK, Lipson J, Walker M**, Paternal age and birth defects: how strong is the association? *Hum Reprod* 22:696, 2007.
107. **Auroux M**, [Age of the father and development], *Contracept Fertil Sex* 21:382, 1993.
108. **Tarin JJ, Brines J, Cano A**, Long-term effects of delayed parenthood, *Hum Reprod* 13:2371, 1998.
109. **Friedman JM**, Genetic disease in the offspring of older fathers, *Obstet Gynecol* 57:745, 1981.
110. **Malaspina D, Harlap S, Fennig S, Heiman D, Nahon D, Feldman D, Susser ES**, Advancing paternal age and the risk of schizophrenia, *Arch Gen Psychiatry* 58:361, 2001.
111. **Sipos A, Rasmussen F, Harrison G, Tynelius P, Lewis G, Leon DA, Gunnell D**, Paternal age and schizophrenia: a population based cohort study, *Br Med J* 329:1070, 2004.
112. **Tsuchiya KJ, Takagai S, Kawai M, Matsumoto H, Nakamura K, Minabe Y, Mori N, Takei N**, Advanced paternal age associated with an elevated risk for schizophrenia in offspring in a Japanese population, *Schizophr Res* 76:337, 2005.
113. **Perrin MC, Brown AS, Malaspina D**, Aberrant epigenetic regulation could explain the relationship of

paternal age to schizophrenia, *Schizophr Bull* 33:1270, 2007.

114. **Reichenberg A, Gross R, Weiser M, Bresnahan M, Silverman J, Harlap S, Rabinowitz J, Shulman C, Malaspina D, Lubin G, Knobler HY, Davidson M, Susser E**, Advancing paternal age and autism, *Arch Gen Psychiatry* 63:1026, 2006.
115. **Tsuchiya KJ, Matsumoto K, Miyachi T, Tsujii M, Nakamura K, Takagai S, Kawai M, Yagi A, Iwaki K, Suda S, Sugihara G, Iwata Y, Matsuzaki H, Sekine Y, Suzuki K, Sugiyama T, Mori N, Takei N**, Paternal age at birth and high-functioning autistic-spectrum disorder in offspring, *Br J Psychiatry* 193:316, 2008.
116. **Durkin MS, Maenner MJ, Newschaffer CJ, Lee LC, Cunniff CM, Daniels JL, Kirby RS, Leavitt L, Miller L, Zahorodny W, Schieve LA**, Advanced parental age and the risk of autism spectrum disorder, *Am J Epidemiol* 168:1268, 2008.
117. **Croen LA, Najjar DV, Fireman B, Grether JK**, Maternal and paternal age and risk of autism spectrum disorders, *Arch Pediatr Adolesc Med* 161:334, 2007.
118. **Lauritsen MB, Pedersen CB, Mortensen PB**, Effects of familial risk factors and place of birth on the risk of autism: a nationwide register-based study, *J Child Psychol Psychiatry* 46:963, 2005.
119. **American College of Obstetricians and Gynecologists**, ACOG committee opinion. Advanced paternal age: risks to the fetus. Number 189, October 1997. Committee on Genetics. American College of Obstetricians and Gynecologists, *Int J Gynaecol Obstet* 59:271, 1997.
120. **Erickson JD**, Paternal age and Down syndrome, *Am J Hum Genet* 31:489, 1979.
121. **Stene J, Fischer G, Stene E, Mikkelsen M, Petersen E**, Paternal age effect in Down's syndrome, *Ann Hum Genet* 40:299, 1977.
122. **Roth MP, Feingold J, Baumgarten A, Bigel P, Stoll C**, Reexamination of paternal age effect in Down's syndrome, *Hum Genet* 63:149, 1983.
123. **Hook EB, Regal RR**, A search for a paternal-age effect upon cases of 47, +21 in which the extra chromosome is of paternal origin, *Am J Hum Genet* 36:413, 1984.
124. **Sloter E, Nath J, Eskenazi B, Wyrobek AJ**, Effects of male age on the frequencies of germinal and heritable chromosomal abnormalities in humans and rodents, *Fertil Steril* 81:925, 2004.
125. **Yip BH, Pawitan Y, Czene K**, Parental age and risk of childhood cancers: a population-based cohort study from Sweden, *Int J Epidemiol* 35:1495, 2006.
126. **Slama R, Bouyer J, Windham G, Fenster L, Werwatz A, Swan SH**, Influence of paternal age on the risk of spontaneous abortion, *Am J Epidemiol* 161:816, 2005.
127. **Nybo Andersen AM, Hansen KD, Andersen PK, Davey Smith G**, Advanced paternal age and risk of fetal death: a cohort study, *Am J Epidemiol* 160:1214, 2004.
128. **Hatch M, Kline J, Levin B, Hutzler M, Warburton D**, Paternal age and trisomy among spontaneous abortions, *Hum Genet* 85:355, 1990.
129. **de la Rochebrochard E, Thonneau P**, Paternal age and maternal age are risk factors for miscarriage; results of a multicentre European study, *Hum Reprod* 17:1649, 2002.
130. **Olshan AF, Ananth CV, Savitz DA**, Intrauterine growth retardation as an endpoint in mutation epidemiology: an evaluation based on paternal age, *Mutat Res* 344:89, 1995.
131. **Chen XK, Wen SW, Krewski D, Fleming N, Yang Q, Walker MC**, Paternal age and adverse birth outcomes: teenager or 40+, who is at risk? *Hum Reprod* 23:1290, 2008.
132. **Astolfi P, De Pasquale A, Zonta LA**, Late paternity and stillbirth risk, *Hum Reprod* 19:2497, 2004.
133. **Harman SM, Metter EJ, Tobin JD, Pearson J, Blackman MR**, Longitudinal effects of aging on serum total and free testosterone levels in healthy men. Baltimore Longitudinal Study of Aging, *J Clin Endocrinol Metab* 86:724, 2001.
134. **Purifoy FE, Koopmans LH, Mayes DM**, Age differences in serum androgen levels in normal adult males, *Hum Biol* 53:499, 1981.
135. **Bremner WJ, Vitiello MV, Prinz PN**, Loss of circadian rhythmicity in blood testosterone levels with aging in normal men, *J Clin Endocrinol Metab* 56:1278, 1983.
136. **Wu FC, Tajar A, Pye SR, Silman AJ, Finn JD, O'Neill TW, Bartfai G, Casanueva F, Forti G, Giwercman A, Huhtaniemi IT, Kula K, Punab M, Boonen S, Vanderschueren D**, Hypothalamic-



pituitary-testicular axis disruptions in older men are differentially linked to age and modifiable risk factors: the European Male Aging Study, *J Clin Endocrinol Metab* 93:2737, 2008.

137. **Travison TG, Araujo AB, Kupelian V, O'Donnell AB, McKinlay JB**, The relative contributions of aging, health, and lifestyle factors to serum testosterone decline in men, *J Clin Endocrinol Metab* 92:549, 2007.
138. **Morley JE, Kaiser FE, Perry HM III, Patrick P, Morley PM, Stauber PM, Vellas B, Baumgartner RN, Garry PJ**, Longitudinal changes in testosterone, luteinizing hormone, and follicle-stimulating hormone in healthy older men, *Metabolism* 46:410, 1997.
139. **Feldman HA, Longcope C, Derby CA, Johannes CB, Araujo AB, Coviello AD, Bremner WJ, McKinlay JB**, Age trends in the level of serum testosterone and other hormones in middle-aged men: longitudinal results from the Massachusetts male aging study, *J Clin Endocrinol Metab* 87:589, 2002.
140. **Couillard C, Gagnon J, Bergeron J, Leon AS, Rao DC, Skinner JS, Wilmore JH, Despres JP, Bouchard C**, Contribution of body fatness and adipose tissue distribution to the age variation in plasma steroid hormone concentrations in men: the HERITAGE Family Study, *J Clin Endocrinol Metab* 85:1026, 2000.
141. **Araujo AB, Esche GR, Kupelian V, O'Donnell AB, Travison TG, Williams RE, Clark RV, McKinlay JB**, Prevalence of symptomatic androgen deficiency in men, *J Clin Endocrinol Metab* 92:4241, 2007.
142. **Davidson JM, Chen JJ, Crapo L, Gray GD, Greenleaf WJ, Catania JA**, Hormonal changes and sexual function in aging men, *J Clin Endocrinol Metab* 57:71, 1983.
143. **Kwan M, Greenleaf WJ, Mann J, Crapo L, Davidson JM**, The nature of androgen action on male sexuality: a combined laboratory-self-report study on hypogonadal men, *J Clin Endocrinol Metab* 57:557, 1983.
144. **Korenman SG, Morley JE, Mooradian AD, Davis SS, Kaiser FE, Silver AJ, Viosca SP, Garza D**, Secondary hypogonadism in older men: its relation to impotence, *J Clin Endocrinol Metab* 71:963, 1990.
145. **van den Beld AW, de Jong FH, Grobbee DE, Pols HA, Lamberts SW**, Measures of bioavailable serum testosterone and estradiol and their relationships with muscle strength, bone density, and body composition in elderly men, *J Clin Endocrinol Metab* 85:3276, 2000.
146. **Sternbach H**, Age-associated testosterone decline in men: clinical issues for psychiatry, *Am J Psychiatry* 155:1310, 1998.
147. **Janowsky JS, Oviatt SK, Orwoll ES**, Testosterone influences spatial cognition in older men, *Behav Neurosci* 108:325, 1994.
148. **Moffat SD, Zonderman AB, Metter EJ, Blackman MR, Harman SM, Resnick SM**, Longitudinal assessment of serum free testosterone concentration predicts memory performance and cognitive status in elderly men, *J Clin Endocrinol Metab* 87:5001, 2002.
149. **Greendale GA, Edelstein S, Barrett-Connor E**, Endogenous sex steroids and bone mineral density in older women and men: the Rancho Bernardo Study, *J Bone Miner Res* 12:1833, 1997.
150. **Vermeulen A, Goemaere S, Kaufman JM**, Testosterone, body composition and aging, *J Endocrinol Invest* 22:110, 1999.
151. **Turner HE, Wass JA**, Gonadal function in men with chronic illness, *Clin Endocrinol (Oxf)* 47:379, 1997.
152. **Kupelian V, Page ST, Araujo AB, Travison TG, Bremner WJ, McKinlay JB**, Low sex hormone-binding globulin, total testosterone, and symptomatic androgen deficiency are associated with development of the metabolic syndrome in nonobese men, *J Clin Endocrinol Metab* 91:843, 2006.
153. **Laaksonen DE, Niskanen L, Punnonen K, Nyysönen K, Tuomainen TP, Valkonen VP, Salonen R, Salonen JT**, Testosterone and sex hormone-binding globulin predict the metabolic syndrome and diabetes in middle-aged men, *Diabetes Care* 27:1036, 2004.
154. **Oh JY, Barrett-Connor E, Wedick NM, Wingard DL**, Endogenous sex hormones and the development of type 2 diabetes in older men and women: the Rancho Bernardo study, *Diabetes Care* 25:55, 2002.
155. **Laughlin GA, Barrett-Connor E, Bergstrom J**, Low serum testosterone and mortality in older men, *J Clin Endocrinol Metab* 93:68, 2008.
156. **Morley JE, Charlton E, Patrick P, Kaiser FE, Cadeau P, McCready D, Perry HM III**, Validation of a screening questionnaire for androgen deficiency in aging males, *Metabolism* 49:1239, 2000.
157. **Smith KW, Feldman HA, McKinlay JB**, Construction and field validation of a self-administered screener for testosterone deficiency (hypogonadism) in aging men, *Clin Endocrinol (Oxf)* 53:703, 2000.

158. **T'Sjoen G, Goemaere S, De Meyere M, Kaufman JM**, Perception of males' aging symptoms, health and well-being in elderly community-dwelling men is not related to circulating androgen levels, *Psychoneuroendocrinology* 29:201, 2004.
159. **Tancredi A, Reginster JY, Schleich F, Pire G, Maassen P, Luyckx F, Legros JJ**, Interest of the androgen deficiency in aging males (ADAM) questionnaire for the identification of hypogonadism in elderly community-dwelling male volunteers, *Eur J Endocrinol* 151:355, 2004.
160. **Morley JE, Perry HM III, Kevorkian RT, Patrick P**, Comparison of screening questionnaires for the diagnosis of hypogonadism, *Maturitas* 53:424, 2006.
161. **Lin YC, Hwang TI, Chiang HS, Yang CR, Wu HC, Wu TL, Huang SP**, Correlations of androgen deficiency with clinical symptoms in Taiwanese males, *Int J Impot Res* 18:343, 2006.
162. **Bhasin S, Cunningham GR, Hayes FJ, Matsumoto AM, Snyder PJ, Swerdloff RS, Montori VM**, Testosterone therapy in adult men with androgen deficiency syndromes: an Endocrine Society clinical practice guideline, *J Clin Endocrinol Metab* 91:1995, 2006.
163. **Nilsson PM, Moller L, Solstad K**, Adverse effects of psychosocial stress on gonadal function and insulin levels in middle-aged males, *J Intern Med* 237:479, 1995.
164. **Vermeulen A, Verdonck L, Kaufman JM**, A critical evaluation of simple methods for the estimation of free testosterone in serum, *J Clin Endocrinol Metab* 84:3666, 1999.
165. **Swerdloff RS**, Proceedings of the Endocrine Society Andropause Consensus Conferences 2000–2001, In: *The Endocrine Society Continuing Medical Education Series*, January 31, 2002.
166. **Advisory Panel on Testosterone Replacement in Men**, Report of National Institute on aging advisory panel on testosterone replacement in men, *J Clin Endocrinol Metab* 86:4611, 2001.
167. **Morales A, Nolan J, Nelson J, Yen SS**, Effects of replacement dose of dehydroepiandrosterone in men and women of advancing age, *J Clin Endocrinol Metab* 78:1360, 1994.
168. **Snyder PJ, Peachey H, Hannoush P, Berlin JA, Loh L, Lenrow DA, Holmes JH, Dlewati A, Santanna J, Rosen CJ, Strom BL**, Effect of testosterone treatment on body composition and muscle strength in men over 65 years of age, *J Clin Endocrinol Metab* 84:2647, 1999.
169. **Kenny AM, Prestwood KM, Gruman CA, Marcello KM, Raisz LG**, Effects of transdermal testosterone on bone and muscle in older men with low bioavailable testosterone levels, *J Gerontol A Biol Sci Med Sci* 56:M266, 2001.
170. **Amory JK, Watts NB, Easley KA, Sutton PR, Anawalt BD, Matsumoto AM, Bremner WJ, Tenover JL**, Exogenous testosterone or testosterone with finasteride increases bone mineral density in older men with low serum testosterone, *J Clin Endocrinol Metab* 89:503, 2004.
171. **Page ST, Amory JK, Bowman FD, Anawalt BD, Matsumoto AM, Bremner WJ, Tenover JL**, Exogenous testosterone (T) alone or with finasteride increases physical performance, grip strength, and lean body mass in older men with low serum T, *J Clin Endocrinol Metab* 90:1502, 2005.
172. **Bhasin S, Singh AB, Mac RP, Carter B, Lee MI, Cunningham GR**, Managing the risks of prostate disease during testosterone replacement therapy in older men: recommendations for a standardized monitoring plan, *J Androl* 24:299, 2003.
173. **Calof OM, Singh AB, Lee ML, Kenny AM, Urban RJ, Tenover JL, Bhasin S**, Adverse events associated with testosterone replacement in middle-aged and older men: a meta-analysis of randomized, placebo-controlled trials, *J Gerontol A Biol Sci Med Sci* 60:1451, 2005.
174. **Marks LS, Mazer NA, Mostaghel E, Hess DL, Dorey FJ, Epstein JI, Veltri RW, Makarov DV, Partin AW, Bostwick DG, Macairan ML, Nelson PS**, Effect of testosterone replacement therapy on prostate tissue in men with late-onset hypogonadism: a randomized controlled trial, *JAMA* 296:2351, 2006.
175. **Matsumoto AM, Sandblom RE, Schoene RB, Lee KA, Giblin EC, Pierson DJ, Bremner WJ**, Testosterone replacement in hypogonadal men: effects on obstructive sleep apnoea, respiratory drives, and sleep, *Clin Endocrinol (Oxf)* 22:713, 1985.
176. **Schneider BK, Pickett CK, Zwillich CW, Weil JV, McDermott MT, Santen RJ, Varano LA, White DP**, Influence of testosterone on breathing during sleep, *J Appl Physiol* 61:618, 1986.
177. **Liu PY, Yee B, Wishart SM, Jimenez M, Jung DG, Grunstein RR, Handelsman DJ**, The short-term

- effects of high-dose testosterone on sleep, breathing, and function in older men, *J Clin Endocrinol Metab* 88:3605, 2003.
178. **Hajjar RR, Kaiser FE, Morley JE**, Outcomes of long-term testosterone replacement in older hypogonadal males: a retrospective analysis, *J Clin Endocrinol Metab* 82:3793, 1997.
  179. **Whitsel EA, Boyko EJ, Matsumoto AM, Anawalt BD, Siscovick DS**, Intramuscular testosterone esters and plasma lipids in hypogonadal men: a meta-analysis, *Am J Med* 111:261, 2001.
  180. **Spratt DI, Carr DB, Merriam GR, Scully RE, Rao PN, Crowley WF Jr**, The spectrum of abnormal patterns of gonadotropin-releasing hormone secretion in men with idiopathic hypogonadotropic hypogonadism: clinical and laboratory correlations, *J Clin Endocrinol Metab* 64:283, 1987.
  181. **Santen RJ, Paulsen CA**, Hypogonadotropic eunuchoidism. I. Clinical study of the mode of inheritance, *J Clin Endocrinol Metab* 36:47, 1973.
  182. **Lieblich JM, Rogol AD, White BJ, Rosen SW**, Syndrome of anosmia with hypogonadotropic hypogonadism (Kallmann syndrome): clinical and laboratory studies in 23 cases, *Am J Med* 73:506, 1982.
  183. **Duke V, Quinton R, Gordon I, Bouloux PM, Woolf AS**, Proteinuria, hypertension and chronic renal failure in X-linked Kallmann's syndrome, a defined genetic cause of solitary functioning kidney, *Nephrol Dial Transplant* 13:1998, 1998.
  184. **Bick D, Franco B, Sherin RJ, Heye B, Pike L, Crawford J, Maddalena A, Incerti B, Pragliola A, Meitinger T, Ballabio A**, Brief report: intragenic deletion of the KALIG-1 gene in Kallmann's syndrome, *N Engl J Med* 326:1752, 1992.
  185. **Hardelin J-P, Levilliers J, Young J, Pholsena M, Legouis R, Kirk J, Boulooux P, Petit C, Schaison G**, Xp22.3 deletions in isolated familial Kallmann's syndrome, *J Clin Endocrinol Metab* 76:827, 1993.
  186. **Sato N, Katsumata N, Kagami M, Hasegawa T, Hori N, Kawakita S, Minowada S, Shimotsuka A, Shishiba Y, Yokozawa M, Yasuda T, Nagasaki K, Hasegawa D, Hasegawa Y, Tachibana K, Naiki Y, Horikawa R, Tanaka T, Ogata T**, Clinical assessment and mutation analysis of Kallmann syndrome 1 (KAL1) and fibroblast growth factor receptor 1 (FGFR1, or KAL2) in five families and 18 sporadic patients, *J Clin Endocrinol Metab* 89:1079, 2004.
  187. **Dode C, Levilliers J, Dupont JM, De Paepe A, Le Du N, Soussi-Yanicostas N, Coimbra RS, Delmaghani S, Compain-Nouaille S, Baverel F, Pecheux C, Le Tessier D, Cruaud C, Delpesch M, Speleman F, Vermeulen S, Amalfitano A, Bachelot Y, Bouchard P, Cabrol S, Carel JC, Delemarre-van de Waal H, Goulet-Salmon B, Kottler ML, Richard O, Sanchez-Franco F, Saura R, Young J, Petit C, Hardelin JP**, Loss-of-function mutations in FGFR1 cause autosomal dominant Kallmann syndrome, *Nat Genet* 33:463, 2003.
  188. **de Roux N, Young J, Brailly-Tabard S, Misrahi M, Milgrom E, Schaison G**, The same molecular defects of the gonadotropin-releasing hormone receptor determine a variable degree of hypogonadism in affected kindred, *J Clin Endocrinol Metab* 84:567, 1999.
  189. **Valdes-Socin H, Salvi R, Daly AF, Gaillard RC, Quatresooz P, Tebeu PM, Pralong FP, Beckers A**, Hypogonadism in a patient with a mutation in the luteinizing hormone beta-subunit gene, *N Engl J Med* 351:2619, 2004.
  190. **Lofrano-Porto A, Barra GB, Giacomini LA, Nascimento PP, Latronico AC, Casulari LA, da Rocha Neves Fde A**, Luteinizing hormone beta mutation and hypogonadism in men and women, *N Engl J Med* 357:897, 2007.
  191. **Bhangoo AP, Hunter CS, Savage JJ, Anhalt H, Pavlakis S, Walvoord EC, Ten S, Rhodes SJ**, Clinical case seminar: a novel LHX3 mutation presenting as combined pituitary hormonal deficiency, *J Clin Endocrinol Metab* 91:747, 2006.
  192. **Cohen RN, Cohen LE, Botero D, Yu C, Sagar A, Jurkiewicz M, Radovick S**, Enhanced repression by HESX1 as a cause of hypopituitarism and septo-optic dysplasia, *J Clin Endocrinol Metab* 88:4832, 2003.
  193. **Wu W, Cogan JD, Pfaffle RW, Dasen JS, Frisch H, O'Connell SM, Flynn SE, Brown MR, Mullis PE, Parks JS, Phillips JA III, Rosenfeld MG**, Mutations in PROP1 cause familial combined pituitary hormone deficiency, *Nat Genet* 18:147, 1998.
  194. **Siemons LJ, Mahler CH**, Hypogonadotropic hypogonadism in hemochromatosis: recovery of reproductive

- function after iron depletion, *J Clin Endocrinol Metab* 65:585, 1987.
195. **Cundy T, Butler J, Bomford A, Williams R**, Reversibility of hypogonadotropic hypogonadism associated with genetic haemochromatosis, *Clin Endocrinol (Oxf)* 38:617, 1993.
  196. **Carter JN, Tyson JE, Tolis G, Van Vliet S, Faiman C, Friesen HG**, Prolactin-screening tumors and hypogonadism in 22 men, *N Engl J Med* 299:847, 1978.
  197. **World Health Organization**, Contraceptive efficacy of testosterone-induced azoospermia and oligozoospermia in normal men, *Fertil Steril* 65:821, 1996.
  198. **MacAdams MR, White RH, Chipps BE**, Reduction of serum testosterone levels during chronic glucocorticoid therapy, *Ann Intern Med* 104:648, 1986.
  199. **Abs R, Verhelst J, Maeyaert J, Van Buyten JP, Opsomer F, Adriaensen H, Verlooy J, Van Havenbergh T, Smet M, Van Acker K**, Endocrine consequences of long-term intrathecal administration of opioids, *J Clin Endocrinol Metab* 85:2215, 2000.
  200. **Finch PM, Roberts LJ, Price L, Hadlow NC, Pullan PT**, Hypogonadism in patients treated with intrathecal morphine, *Clin J Pain* 16:251, 2000.
  201. **Bliesener N, Albrecht S, Schwager A, Weckbecker K, Lichtermann D, Klingmuller D**, Plasma testosterone and sexual function in men receiving buprenorphine maintenance for opioid dependence, *J Clin Endocrinol Metab* 90:203, 2005.
  202. **Spratt DI, Cox P, Orav J, Moloney J, Bigos T**, Reproductive axis suppression in acute illness is related to disease severity, *J Clin Endocrinol Metab* 76:1548, 1993.
  203. **Schneider HJ, Kreitschmann-Andermahr I, Ghigo E, Stalla GK, Agha A**, Hypothalamopituitary dysfunction following traumatic brain injury and aneurysmal subarachnoid hemorrhage: a systematic review, *JAMA* 298:1429, 2007.
  204. **Flannery MT, Pattani S, Wallach PM, Warner E**, Case report: hypothalamic tuberculoma associated with secondary panhypopituitarism, *Am J Med Sci* 306:101, 1993.
  205. **Isidori AM, Caprio M, Strollo F, Moretti C, Frajese G, Isidori A, Fabbri A**, Leptin and androgens in male obesity: evidence for leptin contribution to reduced androgen levels, *J Clin Endocrinol Metab* 84:3673, 1999.
  206. **Allen NE, Appleby PN, Davey GK, Key TJ**, Lifestyle and nutritional determinants of bioavailable androgens and related hormones in British men, *Cancer Causes Control* 13:353, 2002.
  207. **Gapstur SM, Gann PH, Kopp P, Colangelo L, Longcope C, Liu K**, Serum androgen concentrations in young men: a longitudinal analysis of associations with age, obesity, and race. The CARDIA male hormone study, *Cancer Epidemiol Biomarkers Prev* 11:1041, 2002.
  208. **Jensen TK, Andersson AM, Jorgensen N, Andersen AG, Carlsen E, Petersen JH, Skakkebaek NE**, Body mass index in relation to semen quality and reproductive hormones among 1,558 Danish men, *Fertil Steril* 82:863, 2004.
  209. **Tsai EC, Matsumoto AM, Fujimoto WY, Boyko EJ**, Association of bioavailable, free, and total testosterone with insulin resistance: influence of sex hormone-binding globulin and body fat, *Diabetes Care* 27:861, 2004.
  210. **Schwartz ID, Root AW**, The Klinefelter syndrome of testicular dysgenesis, *Endocrinol Metab Clin North Am* 20:153, 1991.
  211. **Bojesen A, Juul S, Gravholt CH**, Prenatal and postnatal prevalence of Klinefelter syndrome: a national registry study, *J Clin Endocrinol Metab* 88:622, 2003.
  212. **Paulsen CA, Gordon DL, Carpenter RW, Gandy HM, Drucker WD**, Klinefelter's syndrome and its variants: a hormonal and chromosomal study, *Recent Prog Horm Res* 24:321, 1968.
  213. **Zitzmann M, Depenbusch M, Gromoll J, Nieschlag E**, X-chromosome inactivation patterns and androgen receptor functionality influence phenotype and social characteristics as well as pharmacogenetics of testosterone therapy in Klinefelter patients, *J Clin Endocrinol Metab* 89:6208, 2004.
  214. **Zinn AR, Ramos P, Elder FF, Kowal K, Samango-Sprouse C, Ross JL**, Androgen receptor CAGn repeat length influences phenotype of 47,XXY (Klinefelter) syndrome, *J Clin Endocrinol Metab* 90:5041, 2005.
  215. **Wang C, Baker HW, Burger HG, De Kretser DM, Hudson B**, Hormonal studies in Klinefelter's

syndrome, *Clin Endocrinol (Oxf)* 4:399, 1975.

216. **Ferlin A, Zuccarello D, Zuccarello B, Chirico MR, Zanon GF, Foresta C**, Genetic alterations associated with cryptorchidism, *JAMA* 300:2271, 2008.
217. **Bender BG, Linden MG, Robinson A**, Neuropsychological impairment in 42 adolescents with sex chromosome abnormalities, *Am J Med Genet* 48:169, 1993.
218. **Simm PJ, Zacharin MR**, The psychosocial impact of Klinefelter syndrome—a 10 year review, *J Pediatr Endocrinol Metab* 19:499, 2006.
219. **Ross JL, Roeltgen DP, Stefanatos G, Benecke R, Zeger MP, Kushner H, Ramos P, Elder FF, Zinn AR**, Cognitive and motor development during childhood in boys with Klinefelter syndrome, *Am J Med Genet A* 146A:708, 2008.
220. **Weiss JR, Moysich KB, Swede H**, Epidemiology of male breast cancer, *Cancer Epidemiol Biomarkers Prev* 14:20, 2005.
221. **Volkl TM, Simm D, Beier C, Dorr HG**, Obesity among children and adolescents with classic congenital adrenal hyperplasia due to 21-hydroxylase deficiency, *Pediatrics* 117:e98, 2006.
222. **Campbell WA, Newton MS, Price WH**, Hypostatic leg ulceration and Klinefelter's syndrome, *J Ment Defic Res* 24:115, 1980.
223. **Scofield RH, Bruner GR, Namjou B, Kimberly RP, Ramsey-Goldman R, Petri M, Reveille JD, Alarcon GS, Vila LM, Reid J, Harris B, Li S, Kelly JA, Harley JB**, Klinefelter's syndrome (47,XXY) in male systemic lupus erythematosus patients: support for the notion of a gene-dose effect from the X chromosome, *Arthritis Rheum* 58:2511, 2008.
224. **Bojesen A, Juul S, Birkebaek NH, Gravholt CH**, Morbidity in Klinefelter syndrome: a Danish register study based on hospital discharge diagnoses, *J Clin Endocrinol Metab* 91:1254, 2006.
225. **Simpson JL**, Male pseudohermaphroditism: genetics and clinical delineation, *Hum Genet* 44:1, 1978.
226. **Ferlin A, Arredi B, Speltra E, Cazzadore C, Selice R, Garolla A, Lenzi A, Foresta C**, Molecular and clinical characterization of Y chromosome microdeletions in infertile men: a 10-year experience in Italy, *J Clin Endocrinol Metab* 92:762, 2007.
227. **Mascarenhas M, Thomas S, Kamath MS, Ramalingam R, Kongari AM, Yuvarani S, Srivastava VM, George K**, Prevalence of chromosomal abnormalities and Y chromosome microdeletion among men with severe semen abnormalities and its correlation with successful sperm retrieval, *J Hum Reprod Sci* 9:187, 2016.
228. **Kuroda-Kawaguchi T, Skaletsky H, Brown LG, Minx PJ, Cordum HS, Waterston RH, Wilson RK, Silber S, Oates R, Rozen S, Page DC**, The AZFc region of the Y chromosome features massive palindromes and uniform recurrent deletions in infertile men, *Nat Genet* 29:279, 2001.
229. **Krausz C, Degl'Innocenti S**, Y chromosome and male infertility: update, 2006, *Front Biosci* 11:3049, 2006.
230. **Luddi A, Margollicci M, Gambera L, Serafini F, Cioni M, De Leo V, Balestri P, Piomboni P**, Spermatogenesis in a man with complete deletion of USP9Y, *N Engl J Med* 360:881, 2009.
231. **Tyler-Smith C, Krausz C**, The will-o'-the-wisp of genetics—hunting for the azoospermia factor gene, *N Engl J Med* 360:925, 2009.
232. **Krausz C, Quintana-Murci L, Barbaux S, Siffroi JP, Rouba H, Delafontaine D, Souleyreau-Therville N, Arvis G, Antoine JM, Erdei E, Taar JP, Tar A, Jeandidier E, Plessis G, Bourgeron T, Dadoune JP, Fellous M, McElreavey K**, A high frequency of Y chromosome deletions in males with nonidiopathic infertility, *J Clin Endocrinol Metab* 84:3606, 1999.
233. **Foresta C, Moro E, Garolla A, Onisto M, Ferlin A**, Y chromosome microdeletions in cryptorchidism and idiopathic infertility, *J Clin Endocrinol Metab* 84:3660, 1999.
234. **McLachlan RI, Aitken RJ, Cram D, Krausz C, O'Bryan M**, Need for standardization and confirmation of STS deletions on the Y chromosome, *Fertil Steril* 90:463, 2008.
235. **Aiman J, Griffin JE, Gazak JM, Wilson JD, MacDonald PC**, Androgen insensitivity as a cause of infertility in otherwise normal men, *N Engl J Med* 300:223, 1979.
236. **Griffin JE**, Androgen resistance—the clinical and molecular spectrum, *N Engl J Med* 326:611, 1992.
237. **von Eckardstein S, Syska A, Gromoll J, Kamischke A, Simoni M, Nieschlag E**, Inverse correlation between sperm concentration and number of androgen receptor CAG repeats in normal men, *J Clin Endocrinol*

Metab 86:2585, 2001.

238. **Wallerand H, Remy-Martin A, Chabannes E, Bermont L, Adessi GL, Bittard H**, Relationship between expansion of the CAG repeat in exon 1 of the androgen receptor gene and idiopathic male infertility, *Fertil Steril* 76:769, 2001.
239. **Casella R, Maduro MR, Misfud A, Lipshultz LI, Yong EL, Lamb DJ**, Androgen receptor gene polyglutamine length is associated with testicular histology in infertile patients, *J Urol* 169:224, 2003.
240. **Dowsing AT, Yong EL, Clark M, McLachlan RI, de Kretser DM, Trounson AO**, Linkage between male infertility and trinucleotide repeat expansion in the androgen-receptor gene, *Lancet* 354:640, 1999.
241. **Rajpert-De Meyts E, Leffers H, Petersen JH, Andersen AG, Carlsen E, Jorgensen N, Skakkebaek NE**, CAG repeat length in androgen-receptor gene and reproductive variables in fertile and infertile men, *Lancet* 359:44, 2002.
242. **Davis-Dao CA, Tuazon ED, Sokol RZ, Cortessis VK**, Male infertility and variation in CAG repeat length in the androgen receptor gene: a meta-analysis, *J Clin Endocrinol Metab* 92:4319, 2007.
243. **Hess RA, Bunick D, Lee KH, Bahr J, Taylor JA, Korach KS, Lubahn DB**, A role for oestrogens in the male reproductive system, *Nature* 390:509, 1997.
244. **Smith EP, Boyd J, Frank GR, Takahashi H, Cohen RM, Specker B, Williams TC, Lubahn DB, Korach KS**, Estrogen resistance caused by a mutation in the estrogen-receptor gene in a man, *N Engl J Med* 331:1056, 1994.
245. **Robertson KM, O'Donnell L, Jones ME, Meachem SJ, Boon WC, Fisher CR, Graves KH, McLachlan RI, Simpson ER**, Impairment of spermatogenesis in mice lacking a functional aromatase (cyp 19) gene, *Proc Natl Acad Sci U S A* 96:7986, 1999.
246. **Nuti F, Krausz C**, Gene polymorphisms/mutations relevant to abnormal spermatogenesis, *Reprod Biomed Online* 16:504, 2008.
247. **Simoni M, Gromoll J, Hoppner W, Kamischke A, Krafft T, Stahle D, Nieschlag E**, Mutational analysis of the follicle-stimulating hormone (FSH) receptor in normal and infertile men: identification and characterization of two discrete FSH receptor isoforms, *J Clin Endocrinol Metab* 84:751, 1999.
248. **Takeda R, Ueda M**, Pituitary-gonadal function in male patients with myotonic dystrophy- serum luteinizing hormone, follicle stimulating hormone and testosterone levels and histological damage of the testis, *Acta Endocrinol (Copenh)* 84:382, 1977.
249. **Teng YN, Lin YM, Lin YH, Tsao SY, Hsu CC, Lin SJ, Tsai WC, Kuo PL**, Association of a single-nucleotide polymorphism of the deleted-in-azoospermia-like gene with susceptibility to spermatogenic failure, *J Clin Endocrinol Metab* 87:5258, 2002.
250. **Teng YN, Lin YM, Sun HF, Hsu PY, Chung CL, Kuo PL**, Association of DAZL haplotypes with spermatogenic failure in infertile men, *Fertil Steril* 86:129, 2006.
251. **Becherini L, Guarducci E, Degl'Innocenti S, Rotondi M, Forti G, Krausz C**, DAZL polymorphisms and susceptibility to spermatogenic failure: an example of remarkable ethnic differences, *Int J Androl* 27:375, 2004.
252. **Tung JY, Rosen MP, Nelson LM, Turek PJ, Witte JS, Cramer DW, Cedars MI, Pera RA**, Variants in Deleted in AZoospermia-Like (DAZL) are correlated with reproductive parameters in men and women, *Hum Genet* 118:730, 2006.
253. **Tung JY, Rosen MP, Nelson LM, Turek PJ, Witte JS, Cramer DW, Cedars MI, Reijo-Pera RA**, Novel missense mutations of the Deleted-in-AZoospermia-Like (DAZL) gene in infertile women and men, *Reprod Biol Endocrinol* 4:40, 2006.
254. **Tal R, Holland R, Belenky A, Konichezky M, Baniel J**, Incidental testicular tumors in infertile men, *Fertil Steril* 82:469, 2004.
255. **Raman JD, Nobert CF, Goldstein M**, Increased incidence of testicular cancer in men presenting with infertility and abnormal semen analysis, *J Urol* 174:1819, 2005.
256. **Rajfer J, Handelsman DJ, Swerdloff RS, Hurwitz R, Kaplan H, Vandergast T, Ehrlich RM**, Hormonal therapy of cryptorchidism. A randomized, double-blind study comparing human chorionic gonadotropin and gonadotropin-releasing hormone, *N Engl J Med* 314:466, 1986.
257. **Lee PA, Coughlin MT, Bellinger MF**, Inhibin B: comparison with indexes of fertility among formerly

- cryptorchid and control men, *J Clin Endocrinol Metab* 86:2576, 2001.
258. **Romeo C, Santoro G**, Varicocele and infertility: why a prevention? *J Endocrinol Invest* 32:559, 2009.
259. **Pryor JL, Howards SS**, Varicocele, *Urol Clin North Am* 14:499, 1987.
260. **Saypol DC, Howards SS, Turner TT, Miller ED Jr**, Influence of surgically induced varicocele on testicular blood flow, temperature, and histology in adult rats and dogs, *J Clin Invest* 68:39, 1981.
261. **Mieusset R, Bujan L, Mondinat C, Mansat A, Pontonnier F, Grandjean H**, Association of scrotal hyperthermia with impaired spermatogenesis in infertile men, *Fertil Steril* 48:1006, 1987.
262. **Beard CM, Benson RC Jr, Kelalis PP, Elveback LR, Kurland LT**, The incidence and outcome of mumps orchitis in Rochester, Minnesota, 1935 to 1974, *Mayo Clin Proc* 52:3, 1977.
263. **Adamopoulos DA, Lawrence DM, Vassilopoulos P, Contoyiannis PA, Swyer GI**, Pituitary-testicular interrelationships in mumps orchitis and other viral infections, *Br Med J* 1:1177, 1978.
264. **Morley JE, Distiller LA, Sagel J, Kok SH, Kay G, Carr P, Katz M**, Hormonal changes associated with testicular atrophy and gynaecomastia in patients with leprosy, *Clin Endocrinol (Oxf)* 6:299, 1977.
265. **Krieger JN, Coombs RW, Collier AC, Koehler JK, Ross SO, Chaloupka K, Murphy VL, Corey L**, Fertility parameters in men infected with human immunodeficiency virus, *J Infect Dis* 164:464, 1991.
266. **Umaphy E**, STD/HIV association: effects on semen characteristics, *Arch Androl* 51:361, 2005.
267. **Gazvani MR, Buckett W, Luckas MJM, Aird IA, Hipkin LJ, Lewis-Jones DI**, Conservative management of azoospermia following steroid abuse, *Hum Reprod* 12:1706, 1997.
268. **Rowley MJ, Leach DR, Warner GA, Heller CG**, Effect of graded doses of ionizing radiation on the human testis, *Radiat Res* 59:665, 1974.
269. **Kandeel FR, Swerdloff RS**, Role of temperature in regulation of spermatogenesis and the use of heating as a method for contraception, *Fertil Steril* 49:1, 1988.
270. **Smith CG, Asch RH**, Drug abuse and reproduction, *Fertil Steril* 48:355, 1987.
271. **Bracken MB, Eskenazi B, Sachse K, McSharry J-E, Hellenbrand K, Leon-Summers L**, Association of cocaine use with sperm concentration, motility, and morphology, *Fertil Steril* 53:315, 1990.
272. **Kunzle R, Mueller MD, Hanggi W, Birkhauser MH, Drescher H, Bersinger NA**, Semen quality of male smokers and nonsmokers in infertile couples, *Fertil Steril* 79:287, 2003.
273. **Spratt DI, Bigos ST, Beitins I, Cox P, Longcope C, Orav J**, Both hyper- and hypogonadotropic hypogonadism occur transiently in acute illness: bio- and immunoactive gonadotropins, *J Clin Endocrinol Metab* 75:1562, 1992.
274. **Handelsman DJ, Dong Q**, Hypothalamo-pituitary gonadal axis in chronic renal failure, *Endocrinol Metab Clin North Am* 22:145, 1993.
275. **Smith SR, Chhetri MK, Johanson J, Radfar N, Migeon CJ**, The pituitary-gonadal axis in men with protein-calorie malnutrition, *J Clin Endocrinol Metab* 41:60, 1975.
276. **Stillman RJ**, In utero exposure to diethylstilbestrol: adverse effects on the reproductive tract and reproductive performance in male and female offspring, *Am J Obstet Gynecol* 142:905, 1982.
277. **Patrizio P, Asch RH, Handelin B, Silber SJ**, Aetiology of congenital absence of vas deferens: genetic study of three generations, *Hum Reprod* 8:215, 1993.
278. **Munro NC, Currie DC, Lindsay KS, Ryder TA, Rutman A, Dewar A, Greenstone MA, Hendry WF, Cole PJ**, Fertility in men with primary ciliary dyskinesia presenting with respiratory infection, *Thorax* 49:684, 1994.
279. **Zariwala MA, Knowles MR, Omran H**, Genetic defects in ciliary structure and function, *Annu Rev Physiol* 69:423, 2007.
280. **Wilton LJ, Teichtahl H, Temple-Smith PD, Johnson JL, Southwick GJ, Burger HG, de Kretser DM**, Young's syndrome (obstructive azoospermia and chronic sinobronchial infection): a quantitative study of axonemal ultrastructure and function, *Fertil Steril* 55:144, 1991.
281. **Ichioka K, Kohei N, Okubo K, Nishiyama H, Terai A**, Obstructive azoospermia associated with chronic sinopulmonary infection and situs inversus totalis, *Urology* 68:204.e5, 2006.
282. **American Society for Reproductive Medicine**, Report on optimal evaluation of the infertile male, *Fertil Steril* 86:S202, 2006.

283. **Lee PA**, Fertility in cryptorchidism. Does treatment make a difference? *Endocrinol Metab Clin North Am* 22:479, 1993.
284. **Sheynkin YR, Hendin BN, Schlegel PN, Goldstein M**, Microsurgical repair of iatrogenic injury to the vas deferens, *J Urol* 159:139, 1998.
285. **Poland ML, Moghissi KS, Giblin PT, Ager JW, Olson JM**, Variation of semen measures within normal men, *Fertil Steril* 44:396, 1985.
286. **Mallidis C, Howard EJ, Baker HW**, Variation of semen quality in normal men, *Int J Androl* 14:99, 1991.
287. **Sherins RJ, Brightwell D, Sternthal PM**, Longitudinal analysis of semen of fertile and infertile men, In: Troen P, Nankin R, eds. *The Testis in Normal and Infertile Men*, Raven Press, New York, 1977, p. 473.
288. **Tielemans E, Heederik D, Burdorf A, Loomis D, Habbeema DF**, Intraindividual variability and redundancy of semen parameters, *Epidemiology* 8:99, 1997.
289. **Chen Z, Toth T, Godfrey-Bailey L, Mercedat N, Schiff I, Hauser R**, Seasonal variation and age-related changes in human semen parameters, *J Androl* 24:226, 2003.
290. **Gyllenborg J, Skakkebaek NE, Nielsen NC, Keiding N, Giwercman A**, Secular and seasonal changes in semen quality among young Danish men: a statistical analysis of semen samples from 1927 donor candidates during 1977–1995, *Int J Androl* 22:28, 1999.
291. **Andolz P, Bielsa MA, Andolz A**, Circannual variation in human semen parameters, *Int J Androl* 24:266, 2001.
292. **Tyler JP, Crockett NG, Driscoll GL**, Studies of human seminal parameters with frequent ejaculation. I. Clinical characteristics, *Clin Reprod Fertil* 1:273, 1982.
293. **Pellestor F, Girardet A, Andreo B**, Effect of long abstinence periods on human sperm quality, *Int J Fertil Menopausal Stud* 39:278, 1994.
294. **MacLeod J, Gold RA**, The male factor in fertility and infertility. II. Spermatozoan counts in 1000 cases of known fertility and 1000 cases of infertile marriage, *J Urol* 66:436, 1951.
295. **MacLeod J, Gold RZ**, The male factor in fertility and infertility. III. An analysis of motile activity in the spermatozoa of 1,000 fertile men and 1,000 men in infertile marriage, *Fertil Steril* 2:187, 1951.
296. **MacLeod J, Gold RZ**, The male factor in fertility and infertility. IV. Sperm morphology in fertile and infertile marriage, *Fertil Steril* 2:394, 1951.
297. **Guzick DS, Overstreet JW, Factor-Litvak P, Brazil CK, Nakajima ST, Coutifaris C, Carson SA, Cisneros P, Steinkampf MP, Hill JA, Xu D, Vogel DL**, Sperm morphology, motility, and concentration in fertile and infertile men, *N Engl J Med* 345:1388, 2001.
298. **Bonde JP, Ernst E, Jensen TK, Hjollund NH, Kolstad H, Henriksen TB, Scheike T, Giwercman A, Olsen J, Skakkebaek NE**, Relation between semen quality and fertility: a population-based study of 430 first-pregnancy planners, *Lancet* 352:1172, 1998.
299. **Jorgensen N, Andersen AG, Eustache F, Irvine DS, Suominen J, Petersen JH, Andersen AN, Auger J, Cawood EH, Horte A, Jensen TK, Jouannet P, Keiding N, Vierula M, Toppari J, Skakkebaek NE**, Regional differences in semen quality in Europe, *Hum Reprod* 16:1012, 2001.
300. **Swan SH, Brazil C, Drobnis EZ, Liu F, Kruse RL, Hatch M, Redmon JB, Wang C, Overstreet JW**, Geographic differences in semen quality of fertile U.S. males, *Environ Health Perspect* 111:414, 2003.
301. **Cooper TG, Neuwinger J, Bahrs S, Nieschlag E**, Internal quality control of semen analysis, *Fertil Steril* 58:172, 1992.
302. **McLachlan RI, Baker HW, Clarke GN, Harrison KL, Matson PL, Holden CA, de Kretser DM**, Semen analysis: its place in modern reproductive medical practice, *Pathology* 35:25, 2003.
303. **World Health Organization**, *Laboratory Manual for the Examination of Human Semen and Sperm-Cervical Mucus Interaction*. 2nd ed, Cambridge University Press, Cambridge, 1987.
304. **World Health Organization**, *Laboratory Manual for the Examination of Human Semen and Sperm-Cervical Mucus Interaction*. 3rd ed, Cambridge University Press, Cambridge, 1992.
305. **World Health Organization**, *Laboratory Manual for the Examination of Human Semen and Sperm-Cervical Mucus Interaction*. 4th ed, Cambridge University Press, Cambridge, 1999.
306. **Cooper TG, Noonan E, von Eckardstein S, Auger J, Baker HW, Behre HM, Haugen TB, Kruger T,**



- Wang C, Mbizvo MT, Vogel song KM**, World Health Organization reference values for human semen characteristics, *Hum Reprod Update* 16:231, 2010.
307. **Sharlip ID, Jarow JP, Belker AM, Lipshultz LI, Sigman M, Thomas AJ, Schlegel PN, Howards SS, Nehra A, Damewood MD, Overstreet JW, Sadovsky R**, Best practice policies for male infertility, *Fertil Steril* 77:873, 2002.
308. **Weiske WH, Salzler N, Schroeder-Printzen I, Weidner W**, Clinical findings in congenital absence of the vasa deferentia, *Andrologia* 32:13, 2000.
309. **Daudin M, Bieth E, Bujan L, Massat G, Pontonnier F, Mieusset R**, Congenital bilateral absence of the vas deferens: clinical characteristics, biological parameters, cystic fibrosis transmembrane conductance regulator gene mutations, and implications for genetic counseling, *Fertil Steril* 74:1164, 2000.
310. **Dohle GR**, Inflammatory-associated obstructions of the male reproductive tract, *Andrologia* 35:321, 2003.
311. **Ozgok Y, Tan MO, Kilciler M, Tahmaz L, Kibar Y**, Diagnosis and treatment of ejaculatory duct obstruction in male infertility, *Eur Urol* 39:24, 2001.
312. **Paick J, Kim SH, Kim SW**, Ejaculatory duct obstruction in infertile men, *BJU Int* 85:720, 2000.
313. **Willott GM**, Frequency of azoospermia, *Forensic Sci Int* 20:9, 1982.
314. **Jarow JP, Espeland MA, Lipshultz LI**, Evaluation of the azoospermic patient, *J Urol* 142:62, 1989.
315. **Silber SJ, Nagy Z, Devroey P, Tournaye H, Van Steirteghem AC**, Distribution of spermatogenesis in the testicles of azoospermic men: the presence or absence of spermatids in the testes of men with germinal failure, *Hum Reprod* 12:2422, 1997.
316. **Ron-El R, Strassburger D, Friedler S, Komarovski D, Bern O, Soffer Y, Raziel A**, Extended sperm preparation: an alternative to testicular sperm extraction in non-obstructive azoospermia, *Hum Reprod* 12:1222, 1997.
317. **Omelet W, Bosmans E, Janssen M, Cox A, Vlasselaer J, Gyselaers W, Vandeput H, Gielen J, Pollet H, Maes M, Steeno O, Kruger T**, Semen parameters in a fertile versus subfertile population: a need for change in the interpretation of semen testing, *Hum Reprod* 12:987, 1997.
318. **Carlsen E, Giwercman A, Keidin N, Skakkebaek NE**, Evidence for decreasing quality of semen during past 50 years, *Br Med J* 305:609, 1992.
319. **Auger J, Kunstmann JM, Czyglik F, Jouannet P**, Decline in semen quality among fertile men in Paris during the last 20 years, *N Engl J Med* 332:281, 1995.
320. **Sherins RJ**, Are semen quality and male infertility changing? *N Engl J Med* 332:327, 1995.
321. **Fisch H, Goluboff ET, Olson JH, Feldshuh J, Broder SH, Barad DH**, Semen analysis in 1283 men from the United States over a 25-year period: no decline in quality, *Fertil Steril* 65:1009, 1996.
322. **Paulsen CA, Berman NG, Wang C**, Data from men in greater Seattle area reveals no downward trend in semen quality: further evidence that deterioration of semen quality is not geographically uniform, *Fertil Steril* 65:1015, 1996.
323. **Rasmussen PE, Erb K, Westergaard LG, Laursen ST**, No evidence for decreasing semen quality in four birth cohorts of 1,055 Danish men born between 1950 and 1970, *Fertil Steril* 68:1059, 1997.
324. **Benshushan A, Shoshani O, Paltiel O, Schenker JG, Lewin A**, Is there really a decrease in sperm parameters among healthy young men? A survey of sperm donations during 15 years, *J Assist Reprod Genet* 14:347, 1997.
325. **Andolz P, Bielsa MA, Vila J**, Evolution of semen quality in North-eastern Spain: a study in 22,759 infertile men over a 36 year period, *Hum Reprod* 14: 731, 1999.
326. **Miller DC, Hollenbeck BK, Smith GD, Randolph JF, Christman GM, Smith YR, Lebovic DI, Ohl DA**, Processed total motile sperm count correlates with pregnancy outcome after intrauterine insemination, *Urology* 60:497, 2002.
327. **Pasqualotto EB, Daitch JA, Hendin BN, Falcone T, Thomas AJ Jr, Nelson DR, Agarwal A**, Relationship of total motile sperm count and percentage motile sperm to successful pregnancy rates following intrauterine insemination, *J Assist Reprod Genet* 16:476, 1999.
328. **Van Voorhis BJ, Barnett M, Sparks AE, Syrop CH, Rosenthal G, Dawson J**, Effect of the total motile sperm count on the efficacy and cost-effectiveness of intrauterine insemination and in vitro fertilization, *Fertil*

Steril 75:661, 2001.

329. **Berg U, Brucker C, Berg FD**, Effect of motile sperm count after swim-up on outcome of intrauterine insemination, *Fertil Steril* 67:747, 1997.
330. **Branigan EF, Estes MA, Muller CH**, Advanced semen analysis: a simple screening test to predict intrauterine insemination success, *Fertil Steril* 71:547, 1999.
331. **Casper RF, Meriano JS, Jarvi KA, Cowen L, Lucato ML**, The hypo-osmotic swelling test for selection of viable sperm for intracytoplasmic sperm injection in men with complete asthenozoospermia, *Fertil Steril* 65:972, 1996.
332. **Kruger TF, Acosta AA, Simmons KF, Swanson RJ, Matta JF, Oehninger S**, Predictive value of abnormal sperm morphology in in vitro fertilization, *Fertil Steril* 49:112, 1988.
333. **Menkveld R, Stander FS, Kotze TJ, Kruger TF, van Zyl JA**, The evaluation of morphological characteristics of human spermatozoa according to stricter criteria, *Hum Reprod* 5:586, 1990.
334. **Kruger TF, Acosta AA, Simmons KF, Swanson RJ, Matta JF, Veeck LL, Morshedi M, Brugo S**, New method of evaluating sperm morphology with predictive value for human in vitro fertilization, *Urology* 30:248, 1987.
335. **Kruger TF, Menkveld R, Stander FS, Lombard CJ, Van der Merwe JP, van Zyl JA, Smith K**, Sperm morphologic features as a prognostic factor in in vitro fertilization, *Fertil Steril* 46:1118, 1986.
336. **Hernandez M, Molina R, Olmedo J, Olmedo SB, Coetzee K, Estofan D**, Prognostic value of the strict criteria: an Argentinian experience, *Arch Androl* 37:87, 1996.
337. **Vawda AI, Gunby J, Younglai EV**, Semen parameters as predictors of in-vitro fertilization: the importance of strict criteria sperm morphology, *Hum Reprod* 11:1445, 1996.
338. **Ombet W, Fourie FL, Vandeput H, Bosmans E, Cox A, Janssen M, Kruger T**, Teratozoospermia and in-vitro fertilization: a randomized prospective study, *Hum Reprod* 9:1479, 1994.
339. **Menkveld R, Kruger TF**, Advantages of strict (Tygerberg) criteria for evaluation of sperm morphology, *Int J Androl* 18(Suppl 2):36, 1995.
340. **Coetzee K, Kruger TF, Lombard CJ**, Predictive value of normal sperm morphology: a structured literature review, *Hum Reprod Update* 4:73, 1998.
341. **Gunalp S, Onculoglu C, Gurgan T, Kruger TF, Lombard CJ**, A study of semen parameters with emphasis on sperm morphology in a fertile population: an attempt to develop clinical thresholds, *Hum Reprod* 16:110, 2001.
342. **Pisarska MD, Casson PR, Cisneros PL, Lamb DJ, Lipshultz LI, Buster JE, Carson SA**, Fertilization after standard in vitro fertilization versus intracytoplasmic sperm injection in subfertile males using sibling oocytes, *Fertil Steril* 71:627, 1999.
343. **Kihaile PE, Misumi J, Hirotsuru K, Kumasako Y, Kisanga RE, Utsunomiya T**, Comparison of sibling oocyte outcomes after intracytoplasmic sperm injection and in vitro fertilization in severe teratozoospermic patients in the first cycle, *Int J Androl* 26:57, 2003.
344. **Hall J, Fishel S, Green S, Fleming S, Hunter A, Stoddart N, Dowell K, Thornton S**, Intracytoplasmic sperm injection versus high insemination concentration in-vitro fertilization in cases of very severe teratozoospermia, *Hum Reprod* 10:493, 1995.
345. **Mansour RT, Aboulghar MA, Serour GI, Amin YM, Ramzi AM**, The effect of sperm parameters on the outcome of intracytoplasmic sperm injection, *Fertil Steril* 64:982, 1995.
346. **Robinson JN, Lockwood GM, Dokras A, Egan DM, Nicholson SC, Ross C, Barlow DH**, Does isolated teratozoospermia affect performance in in-vitro fertilization and embryo transfer?, *Hum Reprod* 9:870, 1994.
347. **Keegan BR, Barton S, Sanchez X, Berkeley AS, Krey LC, Grifo J**, Isolated teratozoospermia does not affect in vitro fertilization outcome and is not an indication for intracytoplasmic sperm injection, *Fertil Steril* 88:1583, 2007.
348. **Zinaman MJ, Brown CC, Selevan SG, Clegg ED**, Semen quality and human fertility: a prospective study with healthy couples, *J Androl* 21:145, 2000.
349. **Menkveld R, Wong WY, Lombard CJ, Wetzels AM, Thomas CM, Merkus HM, Steegers-Theunissen RP**, Semen parameters, including WHO and strict criteria morphology, in a fertile and subfertile

population: an effort towards standardization of in-vivo thresholds, *Hum Reprod* 16:1165, 2001.

350. **Lee RK, Hou JW, Ho HY, Hwu YM, Lin MH, Tsai YC, Su JT**, Sperm morphology analysis using strict criteria as a prognostic factor in intrauterine insemination, *Int J Androl* 25:277, 2002.
351. **Hauser R, Yogev L, Botchan A, Lessing JB, Paz G, Yavetz H**, Intrauterine insemination in male factor subfertility: significance of sperm motility and morphology assessed by strict criteria, *Andrologia* 33:13, 2001.
352. **Toner JP, Mossad H, Grow DR, Morshedi M, Swanson RJ, Oehninger S**, Value of sperm morphology assessed by strict criteria for prediction of the outcome of artificial (intrauterine) insemination, *Andrologia* 27:143, 1995.
353. **Van Waart J, Kruger TF, Lombard CJ, Ombelet W**, Predictive value of normal sperm morphology in intrauterine insemination (IUI): a structured literature review, *Hum Reprod Update* 7:495, 2001.
354. **Karabinus DS, Gelety TJ**, The impact of sperm morphology evaluated by strict criteria on intrauterine insemination success, *Fertil Steril* 67:536, 1997.
355. **Matorras R, Corcostegui B, Perez C, Mandiola M, Mendoza R, Rodriguez-Escudero FJ**, Sperm morphology analysis (strict criteria) in male infertility is not a prognostic factor in intrauterine insemination with husband's sperm, *Fertil Steril* 63:608, 1995.
356. **Hofmann GE, Santilli BA, Kindig S, Scott RT Jr, Johnson CA**, Intraobserver, interobserver variation of sperm critical morphology: comparison of examiner and computer-assisted analysis, *Fertil Steril* 65:1021, 1996.
357. **Franken DR, Barendsen R, Kruger TF**, A continuous quality control program for strict sperm morphology, *Fertil Steril* 74:721, 2000.
358. **Franken DR, Menkveld R, Kruger TF, Sekadde-Kigonda C, Lombard C**, Monitoring technologist reading skills in a sperm morphology quality control program, *Fertil Steril* 79(Suppl 3):1637, 2003.
359. **Wolff H, Anderson DJ**, Immunohistologic characterization and quantitation of leukocyte subpopulations in human semen, *Fertil Steril* 49:497, 1988.
360. **Eggert-Krause W, Bellmann A, Rohr G, Tilgen W, Runnenbaum B**, Differentiation of round cells in semen by means of monoclonal antibodies and relationship with male fertility, *Fertil Steril* 58:1046, 1992.
361. **Wolff H, Politch JA, Martinez A, Haimovici F, Hill JA, Anderson DJ**, Leukocytospermia is associated with poor semen quality, *Fertil Steril* 53:528, 1990.
362. **Ludwig M, Vidal A, Huwe P, Diemer T, Pabst W, Weidner W**, Significance of inflammation on standard semen analysis in chronic prostatitis/chronic pelvic pain syndrome, *Andrologia* 35:152, 2003.
363. **Randall JM, Evans DH, Bird VG, Aballa TC, Lynne CM, Brackett NL**, Leukocytospermia in spinal cord injured patients is not related to histological inflammatory changes in the prostate, *J Urol* 170:897, 2003.
364. **Siciliano L, Tarantino P, Longobardi F, Rago V, De Stefano C, Carpino A**, Impaired seminal antioxidant capacity in human semen with hyperviscosity or oligoasthenozoospermia, *J Androl* 22:798, 2001.
365. **Curi SM, Ariagno JI, Chenlo PH, Mendeluk GR, Pugliese MN, Sardi Segovia LM, Repetto HE, Blanco AM**, Asthenozoospermia: analysis of a large population, *Arch Androl* 49:343, 2003.
366. **Munuce MJ, Bregni C, Carizza C, Mendeluk G**, Semen culture, leukocytospermia, and the presence of sperm antibodies in seminal hyperviscosity, *Arch Androl* 42:21, 1999.
367. **Gonzales GF, Kortebani G, Mazzolli AB**, Hyperviscosity and hypofunction of the seminal vesicles, *Arch Androl* 30:63, 1993.
368. **ESHRE (European Society of Human Reproduction and Embryology) Andrology Special Interest Group**, Consensus workshop on advanced diagnostic andrology techniques, *Hum Reprod* 11:1463, 1996.
369. **Turek PJ**, Infections, immunology, and male infertility, *Infertil Reprod Med Clin North Am* 10:435, 1999.
370. **Eggert-Krause W, Christmann M, Gerhard I, Pohl S, Klinga K, Runnebaum B**, Circulating antisperm antibodies and fertility prognosis: a prospective study, *Hum Reprod* 4:513, 1989.
371. **Collins JA, Burrows EA, Yeo J, Younglai EV**, Frequency and predictive value of antisperm antibodies among infertile couples, *Hum Reprod* 8:592, 1993.
372. **Haas GG Jr**, The inhibitory effect of sperm-associated immunoglobulins on cervical mucus penetration, *Fertil Steril* 46:334, 1986.
373. **Mahony MC, Blackmore PF, Bronson RA, Alexander NJ**, Inhibition of human sperm-zona pellucida tight binding in the presence of antisperm antibody positive polyclonal patient sera, *J Reprod Immunol* 19:287, 1991.

374. **Haas GG Jr, Manganiello P**, A double-blind placebo-controlled study of the use of methylprednisolone in infertile men with sperm-associated immunoglobulins, *Fertil Steril* 47:295, 1987.
375. **Bohring C, Krause W**, Immune infertility: towards a better understanding of sperm (auto)-immunity. The value of proteomic analysis, *Hum Reprod* 18:915, 2003.
376. **Ayvaliotis B, Bronson R, Rosenfeld D, Cooper G**, Conception rates in couples where autoimmunity to sperm is detected, *Fertil Steril* 43:739, 1985.
377. **Ombelet W, Vandeput H, Janssen M, Cox A, Vossen C, Pollet H, Steeno O, Bosmans E**, Treatment of male infertility due to sperm surface antibodies: IUI or IVF?, *Hum Reprod* 12:1165, 1997.
378. **McLachlan RI**, Basis, diagnosis and treatment of immunological infertility in men, *J Reprod Immunol* 57:35, 2002.
379. **Yanagimachi R**, Zona-free hamster eggs: their use in assessing fertilizing capacity and examining chromosomes of human spermatozoa, *Gamete Res* 10:187, 1984.
380. **Smith RG, Johnson A, Lamb D, Lipshultz LI**, Functional tests of spermatozoa. Sperm penetration assay, *Urol Clin North Am* 14:451, 1987.
381. **Aitken RJ, Buckingham DW, Fang HG**, Analysis of the responses of human spermatozoa to A23187 employing a novel technique for assessing the acrosome reaction, *J Androl* 14:132, 1993.
382. **Rogers BJ, Perreault SD, Bentwood BJ, McCarville C, Hale RW, Soderdahl DW**, Variability in the human-hamster in vitro assay for fertility evaluation, *Fertil Steril* 39:204, 1983.
383. **Aitken RJ**, Diagnostic value of the zona-free hamster oocyte penetration test and sperm movement characteristics in oligozoospermia, *Int J Androl* 8:348, 1985.
384. **Mao C, Grimes DA**, The sperm penetration assay: can it discriminate between fertile and infertile men? *Am J Obstet Gynecol* 159:279, 1988.
385. **Margalioth EJ, Feinmesser M, Navot D, Mordel N, Bronson RA**, The long-term predictive value of the zona-free hamster ova sperm penetration assay, *Fertil Steril* 52:490, 1989.
386. **O'Shea DL, Odem RR, Cholewa C, Gast MJ**, Long-term follow-up of couples after hamster egg penetration testing, *Fertil Steril* 60:1040, 1993.
387. **Kruger TF, Swanson RJ, Hamilton M, Simmons KF, Acosta AA, Matta JF, Oehninger S, Morshedi M**, Abnormal sperm morphology and other semen parameters related to the outcome of the hamster oocyte human sperm penetration assay, *Int J Androl* 11:107, 1988.
388. **Soffer Y, Golan A, Herman A, Pansky M, Caspi E, Ron-El R**, Prediction of in vitro fertilization outcome by sperm penetration assay with TEST-yolk buffer preincubation, *Fertil Steril* 58:556, 1992.
389. **Zahalsky MP, Zoltan E, Medley N, Nagler HM**, Morphology and the sperm penetration assay, *Fertil Steril* 79:39, 2003.
390. **Burkman LJ, Coddington CC, Franken DR, Kruger TF, Rosenwaks Z, Hodgen GD**, The hemizona assay (HZA): development of a diagnostic test for the binding of human spermatozoa to the human hemizona pellucida to predict fertilization potential, *Fertil Steril* 49:688, 1988.
391. **Oehninger S, Coddington CC, Scott R, Franken DA, Burkman LJ, Acosta AA, Hodgen GD**, Hemizona assay: assessment of sperm dysfunction and prediction of in vitro fertilization outcome, *Fertil Steril* 51:665, 1989.
392. **Franken DR, Oehninger S, Burkman LJ, Coddington CC, Kruger TF, Rosenwaks Z, Acosta AA, Hodgen GD**, The hemizona assay (HZA): a predictor of human sperm fertilizing potential in in vitro fertilization (IVF) treatment, *J In Vitro Fert Embryo Transf* 6:44, 1989.
393. **Coddington CC III**, The hemizona assay (HZA) and considerations for its use in assisted reproductive technology, *Semin Reprod Endocrinol* 10:1, 1992.
394. **Davis RO, Rothmann SA, Overstreet JW**, Accuracy and precision of computer-aided sperm analysis in multicenter studies, *Fertil Steril* 57:648, 1992.
395. **Davis RO, Katz DF**, Standardization and comparability of CASA instruments, *J Androl* 13:81, 1992.
396. **Barratt CL, Tomlinson MJ, Cooke ID**, Prognostic significance of computerized motility analysis for in vivo fertility, *Fertil Steril* 60:520, 1993.
397. **Krause W**, Computer-assisted semen analysis systems: comparison with routine evaluation and prognostic

- value in male fertility and assisted reproduction, *Hum Reprod* 10(Suppl 1):60, 1995.
398. **Macleod IC, Irvine DS**, The predictive value of computer-assisted semen analysis in the context of a donor insemination programme, *Hum Reprod* 10:580, 1995.
  399. **Liu DY, Baker HWG**, Inhibition of acrosin activity with a trypsin inhibitor blocks human sperm penetration of the zona pellucida, *Biol Reprod* 48:340, 1993.
  400. **Fenichel P, Donzeau M, Farahifar D, Basteris B, Ayraud N, Hsi BL**, Dynamics of human sperm acrosome reaction: relation with in vitro fertilization, *Fertil Steril* 55:994, 1991.
  401. **Huszar G, Vigue L, Oehninger S**, Creatine kinase immunocytochemistry of human sperm-hemizona complexes: selective binding of sperm with mature creatine kinase-staining pattern, *Fertil Steril* 61:136, 1994.
  402. **Rolf C, Behre HM, Cooper TG, Koppers B, Nieschlag E**, Creatine kinase activity in human spermatozoa and seminal plasma lacks predictive value for male fertility in in vitro fertilization, *Fertil Steril* 69:727, 1998.
  403. **Iwasaki A, Gagnon C**, Formation of reactive oxygen species in spermatozoa of infertile patients, *Fertil Steril* 57:409, 1992.
  404. **de Lamirande E, Gagnon C**, Human sperm hyperactivation in whole semen and its association with low superoxide scavenging capacity in seminal plasma, *Fertil Steril* 59:1291, 1993.
  405. **Aitken RJ, Buckingham D, West K, Wu FC, Zikopoulos K, Richardson DW**, Differential contribution of leucocytes and spermatozoa to the generation of reactive oxygen species in the ejaculates of oligozoospermic patients and fertile donors, *J Reprod Fertil* 94:451, 1992.
  406. **Kim JG, Parthasarathy S**, Oxidation and the spermatozoa, *Semin Reprod Endocrinol* 16:235, 1998.
  407. **Irvine DS, Twigg JP, Gordon EL, Fulton N, Milne PA, Aitken RJ**, DNA integrity in human spermatozoa: relationships with semen quality, *J Androl* 21:33, 2000.
  408. **Evenson DP, Jost LK, Marshall D, Zinaman MJ, Clegg E, Purvis K, de Angelis P, Claussen OP**, Utility of the sperm chromatin structure assay as a diagnostic and prognostic tool in the human fertility clinic, *Hum Reprod* 14:1039, 1999.
  409. **Larson KL, DeJonge CJ, Barnes AM, Jost LK, Evenson DP**, Sperm chromatin structure assay parameters as predictors of failed pregnancy following assisted reproductive techniques, *Hum Reprod* 15:1717, 2000.
  410. **Morris ID, Ilott S, Dixon L, Brison DR**, The spectrum of DNA damage in human sperm assessed by single cell gel electrophoresis (Comet assay) and its relationship to fertilization and embryo development, *Hum Reprod* 17:990, 2002.
  411. **Zini A, Fischer MA, Sharir S, Shayegan B, Phang D, Jarvi K**, Prevalence of abnormal sperm DNA denaturation in fertile and infertile men, *Urology* 60:1069, 2002.
  412. **Duran EH, Morshedi M, Taylor S, Oehninger S**, Sperm DNA quality predicts intrauterine insemination outcome: a prospective cohort study, *Hum Reprod* 17:3122, 2002.
  413. **Spano M, Bonde JP, Hjollund HI, Kolstad HA, Cordelli E, Leter G**, Sperm chromatin damage impairs human fertility. The Danish First Pregnancy Planner Study Team, *Fertil Steril* 73:43, 2000.
  414. **Saleh RA, Agarwal A, Nelson DR, Nada EA, El-Tonsy MH, Alvarez JG, Thomas AJ Jr, Sharma RK**, Increased sperm nuclear DNA damage in normozoospermic infertile men: a prospective study, *Fertil Steril* 78:313, 2002.
  415. **Lopes S, Sun JG, Jurisicova A, Meriano J, Casper RF**, Sperm deoxyribonucleic acid fragmentation is increased in poor-quality semen samples and correlates with failed fertilization in intracytoplasmic sperm injection, *Fertil Steril* 69:528, 1998.
  416. **Zini A, Bielecki R, Phang D, Zenzes MT**, Correlations between two markers of sperm DNA integrity, DNA denaturation and DNA fragmentation, in fertile and infertile men, *Fertil Steril* 75:674, 2001.
  417. **Tomlinson MJ, Moffatt O, Manicardi GC, Bizzaro D, Afnan M, Sakkas D**, Interrelationships between seminal parameters and sperm nuclear DNA damage before and after density gradient centrifugation: implications for assisted conception, *Hum Reprod* 16:2160, 2001.
  418. **Larson-Cook KL, Brannian JD, Hansen KA, Kaspersen KM, Aamold ET, Evenson DP**, Relationship between the outcomes of assisted reproductive techniques and sperm DNA fragmentation as measured by the sperm chromatin structure assay, *Fertil Steril* 80:895, 2003.

419. **Collins JA, Barnhart KT, Schlegel PN**, Do sperm DNA integrity tests predict pregnancy with in vitro fertilization? *Fertil Steril* 89:823, 2008.
420. **Sigman M, Jarow JP**, Endocrine evaluation of infertile men, *Urology* 50:659, 1997.
421. **Sokol RZ**, Endocrinology of male infertility: evaluation and treatment, *Semin Reprod Med* 27:149, 2009.
422. **Pavlovich CP, King P, Goldstein M, Schlegel PN**, Evidence of a treatable endocrinopathy in infertile men, *J Urol* 165:837, 2001.
423. **Raman JD, Schlegel PN**, Aromatase inhibitors for male infertility, *J Urol* 167:624, 2002.
424. **Honig SC, Lipshultz LI, Jarow J**, Significant medical pathology uncovered by a comprehensive male infertility evaluation, *Fertil Steril* 62:1028, 1994.
425. **Kolettis PN**, Is physical examination useful in predicting epididymal obstruction? *Urology* 57:1138, 2001.
426. **Gorelick JI, Goldstein M**, Loss of fertility in men with varicocele, *Fertil Steril* 59:613, 1993.
427. **World Health Organization**, The influence of varicocele on parameters of fertility in a large group of men presenting to infertility clinics. World Health Organization, *Fertil Steril* 57:1289, 1992.
428. **Carter SS, Shinohara K, Lipshultz LI**, Transrectal ultrasonography in disorders of the seminal vesicles and ejaculatory ducts, *Urol Clin North Am* 16:773, 1989.
429. **Belker AM, Steinbock GS**, Transrectal prostate ultrasonography as a diagnostic and therapeutic aid for ejaculatory duct obstruction, *J Urol* 144:356, 1990.
430. **Jarow JP**, Seminal vesicle aspiration in the management of patients with ejaculatory duct obstruction, *J Urol* 152:899, 1994.
431. **Jarow JP**, Transrectal ultrasonography in the diagnosis and management of ejaculatory duct obstruction, *J Androl* 17:467, 1996.
432. **Schlegel PN, Shin D, Goldstein M**, Urogenital anomalies in men with congenital absence of the vas deferens, *J Urol* 155:1644, 1996.
433. **Anguiano A, Oates RD, Amos JA, Dean M, Gerrard B, Stewart C, Maher TA, White MB, Milunsky A**, Congenital bilateral absence of the vas deferens. A primarily genital form of cystic fibrosis, *JAMA* 267:1794, 1992.
434. **Oates RD, Amos JA**, The genetic basis of congenital bilateral absence of the vas deferens and cystic fibrosis, *J Androl* 15:1, 1994.
435. **Shin D, Gilbert F, Goldstein M, Schlegel PN**, Congenital absence of the vas deferens: incomplete penetrance of cystic fibrosis gene mutations, *J Urol* 158:1794, 1997.
436. **Foresta C, Garolla A, Bartoloni L, Bettella A, Ferlin A**, Genetic abnormalities among severely oligospermic men who are candidates for intracytoplasmic sperm injection, *J Clin Endocrinol Metab* 90:152, 2005.
437. **Ravel C, Berthaut I, Bresson JL, Siffroi JP**, Prevalence of chromosomal abnormalities in phenotypically normal and fertile adult males: large-scale survey of over 10,000 sperm donor karyotypes, *Hum Reprod* 21:1484, 2006.
438. **De Braekeleer M, Dao TN**, Cytogenetic studies in male infertility: a review, *Hum Reprod* 6:245, 1991.
439. **Rucker GB, Mielnik A, King P, Goldstein M, Schlegel PN**, Preoperative screening for genetic abnormalities in men with nonobstructive azoospermia before testicular sperm extraction, *J Urol* 160:2068, 1998.
440. **Tournaye H, Staessen C, Liebaers I, Van Assche E, Devroey P, Bonduelle M, Van Steirteghem A**, Testicular sperm recovery in nine 47,XXY Klinefelter patients, *Hum Reprod* 11:1644, 1996.
441. **Pryor JL, Kent-First M, Muallem A, Van Bergen AH, Nolten WE, Meisner L, Roberts KP**, Microdeletions in the Y chromosome of infertile men, *N Engl J Med* 336:534, 1997.
442. **Vogt PH, Edelmann A, Kirsch S, Henegrin O, Hirschmann P, Kiesewetter F, Kohn FM, Schill WB, Farah S, Ramos C, Hartmann M, Hartschuh W, Meschede D, Behre HM, Castel A, Nieschlag E, Weidner W, Grone HJ, Jung A, Engel W, Haidl G**, Human Y chromosome azoospermia factors (AZF) mapped to different subregions in Yq11, *Hum Mol Genet* 5:933, 1996.
443. **Mulhall JP, Reijo R, Alagappan R, Brown L, Page D, Carson R, Oates RD**, Azoospermic men with deletion of the DAZ gene cluster are capable of completing spermatogenesis: fertilization, normal embryonic

development and pregnancy occur when retrieved testicular spermatozoa are used for intracytoplasmic sperm injection, *Hum Reprod* 12:503, 1997.

444. **Oates RD, Silber S, Brown LG, Page DC**, Clinical characterization of 42 oligospermic or azospermic men with microdeletion of the AZFc region of the Y chromosome, and of 18 children conceived via ICSI, *Hum Reprod* 17:2813, 2002.
445. **Kamp C, Huellen K, Fernandes S, Sousa M, Schlegel PN, Mielnik A, Kleiman S, Yavetz H, Krause W, Kupker W, Johannisson R, Schulze W, Weidner W, Barros A, Vogt PH**, High deletion frequency of the complete AZFa sequence in men with Sertoli-cell-only syndrome, *Mol Hum Reprod* 7:987, 2001.
446. **Krausz C, Quintana-Murci L, McElreavey K**, Prognostic value of Y deletion analysis: what is the clinical prognostic value of Y chromosome microdeletion analysis? *Hum Reprod* 15:1431, 2000.
447. **Brandell RA, Mielnik A, Liotta D, Ye Z, Veeck LL, Palermo GD, Schlegel PN**, AZFb deletions predict the absence of spermatozoa with testicular sperm extraction: preliminary report of a prognostic genetic test, *Hum Reprod* 13:2812, 1998.
448. **Kent-First M, Muallem A, Shultz J, Pryor J, Roberts K, Nolten W, Meisner L, Chandley A, Gouchy G, Jorgensen L, Havighurst T, Grosch J**, Defining regions of the Y-chromosome responsible for male infertility and identification of a fourth AZF region (AZFd) by Y-chromosome microdeletion detection, *Mol Reprod Dev* 53:27, 1999.
449. **Silber SJ, Repping S**, Transmission of male infertility to future generations: lessons from the Y chromosome, *Hum Reprod Update* 8:217, 2002.
450. **Cram DS, Ma K, Bhasin S, Arias J, Pandjaitan M, Chu B, Audrins MS, Saunders D, Quinn F, deKretser D, McLachlan R**, Y chromosome analysis of infertile men and their sons conceived through intracytoplasmic sperm injection: vertical transmission of deletions and rarity of de novo deletions, *Fertil Steril* 74:909, 2000.
451. **Chang PL, Sauer MV, Brown S**, Y chromosome microdeletion in a father and his four infertile sons, *Hum Reprod* 14:2689, 1999.
452. **Nathanson KL, Kanetsky PA, Hawes R, Vaughn DJ, Letrero R, Tucker K, Friedlander M, Phillips KA, Hogg D, Jewett MA, Lohynska R, Dugaard G, Richard S, Chompert A, Bonaiti-Pellie C, Heidenreich A, Olah E, Geczi L, Bodrogi I, Ormiston WJ, Daly PA, Oosterhuis JW, Gillis AJ, Looijenga LH, Guilford P, Fossa SD, Heimdal K, Tjulandin SA, Liubchenko L, Stoll H, Weber W, Rudd M, Huddart R, Crockford GP, Forman D, Oliver DT, Einhorn L, Weber BL, Kramer J, McMaster M, Greene MH, Pike M, Cortessis V, Chen C, Schwartz SM, Bishop DT, Easton DF, Stratton MR, Rapley EA**, The Y deletion gr/gr and susceptibility to testicular germ cell tumor, *Am J Hum Genet* 77:1034, 2005.
453. **Kallmann FJ, Schoenfeld WA, Barrera SE**, The genetic aspects of primary eunuchoidism, *Am J Ment Defic* 48:203, 1944.
454. **Nachtigall LB, Boepple PA, Pralong FP, Crowley WF Jr**, Adult-onset idiopathic hypogonadotropic hypogonadism—a treatable form of male infertility, *N Engl J Med* 336:410, 1997.
455. **Nishimura K, Matsumiya K, Tsuboniwa N, Yamanaka M, Koga M, Miura H, Tsujimura A, Uchida K, Kondoh N, Kitamura M, Okuyama A**, Bromocriptine for infertile males with mild hyperprolactinemia: hormonal and spermatogenic effects, *Arch Androl* 43:207, 1999.
456. **Arafah BM, Manni A, Brodkey JS, Kaufman B, Velasco M, Pearson OH**, Cure of hypogonadism after removal of prolactin-secreting adenomas in men, *J Clin Endocrinol Metab* 52:91, 1981.
457. **Winters SJ, Troen P**, Altered pulsatile secretion of luteinizing hormone in hypogonadal men with hyperprolactinaemia, *Clin Endocrinol (Oxf)* 21:257, 1984.
458. **De Rosa M, Colao A, Di Sarno A, Ferone D, Landi ML, Zarrilli S, Paesano L, Merola B, Lombardi G**, Cabergoline treatment rapidly improves gonadal function in hyperprolactinemic males: a comparison with bromocriptine, *Eur J Endocrinol* 138:286, 1998.
459. **Murray FT, Cameron DF, Ketchum C**, Return of gonadal function in men with prolactin-secreting pituitary tumors, *J Clin Endocrinol Metab* 59:79, 1984.
460. **Merino G, Carranza-Lira S, Martinez-Chequer JC, Barahona E, Moran C, Bermudez JA**,

Hyperprolactinemia in men with asthenozoospermia, oligozoospermia, or azoospermia, *Arch Androl* 38:201, 1997.

461. **Vandekerckhove P, Lilford R, Vail A, Hughes E**, Bromocriptine for idiopathic oligo/asthenospermia, *Cochrane Database Syst Rev* (2):CD000152, 2000.
462. **Matsumoto AM, Paulsen CA, Bremner WJ**, Stimulation of sperm production by human luteinizing hormone in gonadotropin-suppressed normal men, *J Clin Endocrinol Metab* 59:882, 1984.
463. **Matsumoto AM, Bremner WJ**, Stimulation of sperm production by human chorionic gonadotropin after prolonged gonadotropin suppression in normal men, *J Androl* 6:137, 1985.
464. **Burris AS, Rodbard HW, Winters SJ, Sherins RJ**, Gonadotropin therapy in men with isolated hypogonadotropic hypogonadism: the response to human chorionic gonadotropin is predicted by initial testicular size, *J Clin Endocrinol Metab* 66:1144, 1988.
465. **Burris AS, Clark RV, Vantman DJ, Sherins RJ**, A low sperm concentration does not preclude fertility in men with isolated hypogonadotropic hypogonadism after gonadotropin therapy, *Fertil Steril* 50:343, 1988.
466. **Bouloux PM, Nieschlag E, Burger HG, Skakkebaek NE, Wu FC, Handelsman DJ, Baker GH, Ochsenkuehn R, Syska A, McLachlan RI, Giwercman A, Conway AJ, Turner L, van Kuijk JH, Voortman G**, Induction of spermatogenesis by recombinant follicle-stimulating hormone (puregon) in hypogonadotropic azoospermic men who failed to respond to human chorionic gonadotropin alone, *J Androl* 24:604, 2003.
467. **Depenbusch M, von Eckardstein S, Simoni M, Nieschlag E**, Maintenance of spermatogenesis in hypogonadotropic hypogonadal men with human chorionic gonadotropin alone, *Eur J Endocrinol* 147:617, 2002.
468. **Crowley WF, Whitcomb RW**, Gonadotropin-releasing hormone deficiency in men: diagnosis and treatment with exogenous gonadotropin-releasing hormone, *Am J Obstet Gynecol* 163:1752, 1990.
469. **Christiansen P, Skakkebaek NE**, Pulsatile gonadotropin-releasing hormone treatment of men with idiopathic hypogonadotropic hypogonadism, *Horm Res* 57:32, 2002.
470. **Giusti M, Cavagnaro P, Torre R**, Role of pulsatile luteinizing hormone releasing-hormone therapy in males with idiopathic hypogonadotropic hypogonadism and delayed puberty, *Recenti Prog Med* 82:47, 1991.
471. **Spratt DI, Finkelstein JS, O'Dea LS, Badger TM, Rao PN, Campbell JD, Crowley WF Jr**, Long-term administration of gonadotropin-releasing hormone in men with idiopathic hypogonadotropic hypogonadism. A model for studies of the hormone's physiologic effects, *Ann Intern Med* 105:848, 1986.
472. **Hoffman AR, Crowley WF Jr**, Induction of puberty in men by long-term pulsatile administration of low-dose gonadotropin-releasing hormone, *N Engl J Med* 307:1237, 1982.
473. **Aulitzky W, Frick J, Galvan G**, Pulsatile luteinizing hormone-releasing hormone treatment of male hypogonadotropic hypogonadism, *Fertil Steril* 50:480, 1988.
474. **Pitteloud N, Hayes FJ, Dwyer A, Boepple PA, Lee H, Crowley WF Jr**, Predictors of outcome of long-term GnRH therapy in men with idiopathic hypogonadotropic hypogonadism, *J Clin Endocrinol Metab* 87:4128, 2002.
475. **Liu L, Banks SM, Barnes KM, Sherins RJ**, Two-year comparison of testicular responses to pulsatile gonadotropin-releasing hormone and exogenous gonadotropins from the inception of therapy in men with isolated hypogonadotropic hypogonadism, *J Clin Endocrinol Metab* 67:1140, 1988.
476. **Kliesch S, Behre HM, Nieschlag E**, High efficacy of gonadotropin or pulsatile gonadotropin-releasing hormone treatment in hypogonadotropic hypogonadal men, *Eur J Endocrinol* 131:347, 1994.
477. **Hershlag A, Schiff SF, DeCherney AH**, Retrograde ejaculation, *Hum Reprod* 6:255, 1991.
478. **Yavetz H, Yögev L, Hauser R, Lessing JB, Paz G, Homonnai ZT**, Retrograde ejaculation, *Hum Reprod* 9:381, 1994.
479. **Gerig NE, Meacham RB, Ohl DA**, Use of electroejaculation in the treatment of ejaculatory failure secondary to diabetes mellitus, *Urology* 49:239, 1997.
480. **Yanushpolsky EH, Politch JA, Hill JA, Anderson DJ**, Is leukocytospermia clinically relevant? *Fertil Steril* 66:822, 1996.
481. **Yanushpolsky EH, Politch JA, Hill JA, Anderson DJ**, Antibiotic therapy and leukocytospermia: a prospective, randomized, controlled study, *Fertil Steril* 63:142, 1995.



482. **Erel CT, Senturk LM, Demir F, Irez T, Ertungealp E**, Antibiotic therapy in men with leukocytospermia, *Int J Fertil Womens Med* 42:206, 1997.
483. **Hua VN, Schaeffer AJ**, Acute and chronic prostatitis, *Med Clin North Am* 88:483, 2004.
484. **Trum JW, Mol BW, Pannekoek Y, Spanjaard L, Wertheim P, Bleker OP, van der Veen F**, Value of detecting leukocytospermia in the diagnosis of genital tract infection in subfertile men, *Fertil Steril* 70:315, 1998.
485. **Tomlinson MJ, Barratt CL, Cooke ID**, Prospective study of leukocytes and leukocyte subpopulations in semen suggests they are not a cause of male infertility, *Fertil Steril* 60:1069, 1993.
486. **Vandekerckhove P, Lilford R, Vail A, Hughes E**, Androgens versus placebo or no treatment for idiopathic oligo/asthenospermia, *Cochrane Database Syst Rev* (2):CD000150, 2000.
487. **Liu PY, Handelsman DJ**, The present and future state of hormonal treatment for male infertility, *Hum Reprod Update* 9:9, 2003.
488. **Kamischke A, Behre HM, Bergmann M, Simoni M, Schafer T, Nieschlag E**, Recombinant human follicle stimulating hormone for treatment of male idiopathic infertility: a randomized, double-blind, placebo-controlled, clinical trial, *Hum Reprod* 13:596, 1998.
489. **Matorras R, Perez C, Corcostegui B, Pijoan JI, Ramon O, Delgado P, Rodriguez-Escudero FJ**, Treatment of the male with follicle-stimulating hormone in intrauterine insemination with husband's spermatozoa: a randomized study, *Hum Reprod* 12:24, 1997.
490. **Foresta C, Bettella A, Merico M, Garolla A, Ferlin A, Rossato M**, Use of recombinant human follicle-stimulating hormone in the treatment of male factor infertility, *Fertil Steril* 77:238, 2002.
491. **Foresta C, Bettella A, Garolla A, Ambrosini G, Ferlin A**, Treatment of male idiopathic infertility with recombinant human follicle-stimulating hormone: a prospective, controlled, randomized clinical study, *Fertil Steril* 84:654, 2005.
492. **Attia AM, Al-Inany HG, Farquhar C, Proctor M**, Gonadotrophins for idiopathic male factor subfertility, *Cochrane Database Syst Rev* (1):CD005071, 2007.
493. **World Health Organization**, A double-blind trial of clomiphene citrate for the treatment of idiopathic male infertility. World Health Organization, *Int J Androl* 15:299, 1992.
494. **Vandekerckhove P, Lilford R, Vail A, Hughes E**, Clomiphene or tamoxifen for idiopathic oligo/asthenospermia, *Cochrane Database Syst Rev* (2):CD000151, 2000.
495. **Gorrill MJ, Burry KA, Patton PE**, Pregnancy outcomes using donor sperm insemination after failed in vitro fertilization with intracytoplasmic sperm injection cycles in couples with complex infertility disorders, *Fertil Steril* 80:936, 2003.
496. **O'Brien P, Vandekerckhove P**, Intra-uterine versus cervical insemination of donor sperm for subfertility, *Cochrane Database Syst Rev* (2):CD000317, 2000.
497. **Goldberg JM, Mascha E, Falcone T, Attaran M**, Comparison of intrauterine and intracervical insemination with frozen donor sperm: a meta-analysis, *Fertil Steril* 72:792, 1999.
498. **van der Westerlaken LA, Naaktgeboren N, Helmerhorst FM**, Evaluation of pregnancy rates after intrauterine insemination according to indication, age, and sperm parameters, *J Assist Reprod Genet* 15:359, 1998.
499. **Campana A, Sakkas D, Stalberg A, Bianchi PG, Comte I, Pache T, Walker D**, Intrauterine insemination: evaluation of the results according to the woman's age, sperm quality, total sperm count per insemination and life table analysis, *Hum Reprod* 11:732, 1996.
500. **Guzick DS, Carson SA, Coutifaris C, Overstreet JW, Factor-Litvak P, Steinkampf MP, Hill JA, Mastroianni L Jr, Buster JE, Nakajimi ST, Vogel DL, Canfield RE; for the National Cooperative Reproductive Medicine Network**, Efficacy of superovulation and intrauterine insemination in the treatment of infertility, *N Engl J Med* 340:177, 1999.
501. **Ford WC, Mathur RS, Hull MG**, Intrauterine insemination: is it an effective treatment for male factor infertility? *Baillieres Clin Obstet Gynaecol* 11:691, 1997.
502. **Byrd W, Edman C, Bradshaw K, Odom J, Carr B, Ackerman G**, A prospective randomized study of pregnancy rates following intrauterine and intracervical insemination using frozen donor sperm, *Fertil Steril* 53:521, 1990.

503. **Botchan A, Hauser R, Gamzu R, Yogev L, Paz G, Yavetz H**, Results of 6139 artificial insemination cycles with donor spermatozoa, *Hum Reprod* 16:2298, 2001.
504. **Wolf DP, Patton PE, Burry KA, Kaplan PF**, Intrauterine insemination-ready versus conventional semen cryopreservation for donor insemination: a comparison of retrospective results and a prospective, randomized trial, *Fertil Steril* 76:181, 2001.
505. **Williams RS, Alderman J**, Predictors of success with the use of donor sperm, *Am J Obstet Gynecol* 185:332, 2001.
506. **Ferrara I, Balet R, Grudzinskas JG**, Intrauterine insemination with frozen donor sperm. Pregnancy outcome in relation to age and ovarian stimulation regime, *Hum Reprod* 17:2320, 2002.
507. **Pittrof RU, Shaker A, Dean N, Bekir JS, Campbell S, Tan SL**, Success of intrauterine insemination using cryopreserved donor sperm is related to the age of the woman and the number of preovulatory follicles, *J Assist Reprod Genet* 13:310, 1996.
508. **Kerin J, Byrd W**, Supracervical placement of spermatozoa, In: Soules MR, ed. *Controversies in Reproductive Endocrinology and Infertility*, Elsevier, Amsterdam, 1989.
509. **Nulsen JC, Walsh S, Dumez S, Metzger DA**, A randomized and longitudinal study of human menopausal gonadotropin with intrauterine insemination in the treatment of infertility, *Obstet Gynecol* 82:780, 1993.
510. **Tur-Kaspa I, Dudkiewicz A, Confino E, Gleicher N**, Pooled sequential ejaculates: a way to increase the total number of motile sperm from oligospermic men, *Fertil Steril* 54:906, 1990.
511. **Lindheim SR, Barad DH, Zinger M, Witt B, Amin H, Cohen B, Fisch H, Barg P**, Abnormal sperm morphology is highly predictive of pregnancy outcome during controlled ovarian hyperstimulation and intrauterine insemination, *J Assist Reprod Genet* 13:569, 1996.
512. **Chauhan M, Barratt CL, Cooke SM, Cooke ID**, Differences in the fertility of donor insemination recipients—a study to provide prognostic guidelines as to its success and outcome, *Fertil Steril* 51:815, 1989.
513. **Ahmed Ebbiary N, Martin K, Gibbs A, D'Arcy Y, Afnan M, Newton JR**, Spontaneous ovulatory cycle donor insemination programme: prognostic indicators of a successful pregnancy, *Hum Reprod* 9:1852, 1994.
514. **Shenfield F, Doyle P, Valentine A, Steele SJ, Tan S-L**, Effects of age, gravidity and male infertility status on cumulative conception rates following artificial insemination with cryopreserved donor semen: analysis of 2998 cycles of treatment in one centre over 10 years, *Hum Reprod* 8:60, 1993.
515. **Kang BM, Wu TC**, Effect of age on intrauterine insemination with frozen donor sperm, *Obstet Gynecol* 88:93, 1996.
516. **Corson SL**, Factors affecting donor artificial insemination success rates, *Fertil Steril* 33:415, 1980.
517. **Smith KD, Rodriguez-Rigau LJ, Steinberger E**, The influence of ovulatory dysfunction and timing of insemination on the success of artificial insemination donor (AID) with fresh or cryopreserved semen, *Fertil Steril* 36:496, 1981.
518. **Bradshaw KD, Guzick DS, Grun B, Johnson N, Ackerman G**, Cumulative pregnancy rates for donor insemination according to ovulatory function and tubal status, *Fertil Steril* 48:1051, 1987.
519. **Nash D, Haning RV Jr, Shapiro SS**, The value of hysterosalpingography prior to donor artificial insemination, *Fertil Steril* 31:378, 1979.
520. **Guzick DS, Sullivan MW, Adamson GD, Cedars MI, Falk RJ, Peterson EP, Steinkampf MP**, Efficacy of treatment of unexplained infertility, *Fertil Steril* 70:207, 1998.
521. **American Society for Reproductive Medicine**, Effectiveness and Treatment for Unexplained Infertility. A Practice Committee Report, American Society for Reproductive Medicine, Birmingham, 2000.
522. **Depypere HT, Gordts S, Campo R, Comhaire F**, Methods to increase the success rate of artificial insemination with donor semen, *Hum Reprod* 9:661, 1994.
523. **Lashen H, Afnan M, Kennefik A**, Early resort to ovarian stimulation improves the cost-effectiveness of a donor insemination programme, *Hum Reprod* 14:1983, 1999.
524. **Matorras R, Diaz T, Corcostegui B, Ramon O, Pijoan JI, Rodriguez-Escudero FJ**, Ovarian stimulation in intrauterine insemination with donor sperm: a randomized study comparing clomiphene citrate in fixed protocol versus highly purified urinary FSH, *Hum Reprod* 17:2107, 2002.
525. **Carrell DT, Kuneck PH, Peterson CM, Hatasaka HH, Jones KP, Campbell BF**, A randomized,

prospective analysis of five sperm preparation techniques before intrauterine insemination of husband sperm, *Fertil Steril* 69:122, 1998.

526. **Morshedi M, Duran HE, Taylor S, Oehninger S**, Efficacy and pregnancy outcome of two methods of semen preparation for intrauterine insemination: a prospective randomized study, *Fertil Steril* 79(Suppl 3):1625, 2003.
527. **Boomsma CM, Heineman MJ, Cohlen BJ, Farquhar C**, Semen preparation techniques for intrauterine insemination, *Cochrane Database Syst Rev* (4):CD004507, 2007.
528. **Aitken RJ, Clarkson JS**, Significance of reactive oxygen species and antioxidants in defining the efficacy of sperm preparation techniques, *J Androl* 9:367, 1988.
529. **Mortimer D**, Sperm preparation techniques and iatrogenic failures of in-vitro fertilization, *Hum Reprod* 6:173, 1991.
530. **Henkel RR, Schill WB**, Sperm preparation for ART, *Reprod Biol Endocrinol* 1:108, 2003.
531. **Mahadevan M, Baker G**, Assessment and preparation of semen for in vitro fertilization, In: Wood C, Trounson AO, eds. *Clinical In Vitro Fertilization*, Springer-Verlag, Berlin, 1984, p. 83.
532. **Pousette A, Akerlof E, Rosenborg L, Fredricsson B**, Increase in progressive motility and improved morphology of human spermatozoa following their migration through Percoll gradients, *Int J Androl* 9:1, 1986.
533. **Prakash P, Leykin L, Chen Z, Toth T, Sayegh R, Schiff I, Isaacson K**, Preparation by differential gradient centrifugation is better than swim-up in selecting sperm with normal morphology (strict criteria), *Fertil Steril* 69:722, 1998.
534. **Lim CC, Lewis SE, Kennedy M, Donnelly ET, Thompson W**, Human sperm morphology and in vitro fertilization: sperm tail defects are prognostic for fertilization failure, *Andrologia* 30:43, 1998.
535. **Wilcox AJ, Weinberg CR, Baird DD**, Post-ovulatory ageing of the human oocyte and embryo failure, *Hum Reprod* 13:394, 1998.
536. **Wilcox AJ, Weinberg CR, Baird DD**, Timing of sexual intercourse in relation to ovulation. Effects on the probability of conception, survival of the pregnancy, and sex of the baby, *N Engl J Med* 333:1517, 1995.
537. **Dunson DB, Baird DD, Wilcox AJ, Weinberg CR**, Day-specific probabilities of clinical pregnancy based on two studies with imperfect measures of ovulation, *Hum Reprod* 14:1835, 1999.
538. **Nijs M, Ombelet W**, Cryopreservation of human sperm, *Hum Fertil (Camb)* 4:158, 2001.
539. **Miller PB, Soules MR**, The usefulness of a urinary LH kit for ovulation prediction during menstrual cycles of normal women, *Obstet Gynecol* 87:13, 1996.
540. **Nielsen MS, Barton SD, Hatasaka HH, Stanford JB**, Comparison of several one-step home urinary luteinizing hormone detection test kits to OvuQuick, *Fertil Steril* 76:384, 2001.
541. **Ragni G, Maggioni P, Guermandi E, Testa A, Baroni E, Colombo M, Crosignani PG**, Efficacy of double intrauterine insemination in controlled ovarian hyperstimulation cycles, *Fertil Steril* 72:619, 1999.
542. **Ransom MX, Blotner MB, Bohrer M, Corsan G, Kemmann E**, Does increasing frequency of intrauterine insemination improve pregnancy rates significantly during ovulation induction cycles? *Fertil Steril* 61:303, 1994.
543. **Alborzi S, Motazedian S, Parsanezhad ME, Jannati S**, Comparison of the effectiveness of single intrauterine insemination (IUI) versus double IUI per cycle in infertile patients, *Fertil Steril* 80:595, 2003.
544. **Osuna C, Matorras R, Pijoan JI, Rodriguez-Escudero FJ**, One versus two inseminations per cycle in intrauterine insemination with sperm from patients' husbands: a systematic review of the literature, *Fertil Steril* 82:17, 2004.
545. **Cantineau AE, Heineman MJ, Cohlen BJ**, Single versus double intrauterine insemination in stimulated cycles for subfertile couples: a systematic review based on a Cochrane review, *Hum Reprod* 18:941, 2003.
546. **Lincoln SR, Long CA, Cowan BD**, One artificial insemination per cycle with donor sperm is as efficacious as two inseminations, *J Assist Reprod Genet* 12:67, 1995.
547. **Meyer WR, Smith PM, Clark MR, Cusmano LL, Fritz MA**, Therapeutic cup insemination with cryopreserved donor sperm: prognostic value of cervical mucus score at insemination and the number of motile sperm in mucus at 24 hours, *Fertil Steril* 66:435, 1996.
548. **Patton PE, Burry KA, Thurmond A, Novy MJ, Wolf DP**, Intrauterine insemination outperforms intracervical insemination in a randomized, controlled study with frozen, donor semen, *Fertil Steril* 57:559, 1992.

549. **Hurd WW, Menge AC, Randolph JF Jr, Ohl DA, Ansbacher R, Brown AN**, Comparison of intracervical, intrauterine, and intratubal techniques for donor insemination, *Fertil Steril* 59:339, 1993.
550. **Khalil MR, Rasmussen PE, Erb K, Laursen SB, Rex S, Westergaard LG**, Intrauterine insemination with donor semen. An evaluation of prognostic factors based on a review of 1131 cycles, *Acta Obstet Gynecol Scand* 80:342, 2001.
551. **Practice Committee of the American Society for Reproductive Medicine**, 2008 Guidelines for gamete and embryo donation: a Practice Committee report, *Fertil Steril* 90:S30, 2008.
552. **Marshburn PB, McIntire D, Carr BR, Byrd W**, Spermatozoal characteristics from fresh and frozen donor semen and their correlation with fertility outcome after intrauterine insemination, *Fertil Steril* 58:179, 1992.
553. **Stewart GJ, Tyler JP, Cunningham AL, Barr JA, Driscoll GL, Gold J, Lamont BJ**, Transmission of human T-cell lymphotropic virus type III (HTLV-III) by artificial insemination by donor, *Lancet* 2:581, 1985.
554. **Thyer AC, Patton PE, Burry KA, Mixon BA, Wolf DP**, Fecundability trends among sperm donors as a measure of donor performance, *Fertil Steril* 71: 891, 1999.
555. **Carrell DT, Cartmill D, Jones KP, Hatasaka HH, Peterson CM**, Prospective, randomized, blinded evaluation of donor semen quality provided by seven commercial sperm banks, *Fertil Steril* 78:16, 2002.
556. **Kolettis PN, Thomas AJ Jr**, Vasoepididymostomy for vasectomy reversal: a critical assessment in the era of intracytoplasmic sperm injection, *J Urol* 158: 467, 1997.
557. **Pavlovich CP, Schlegel PN**, Fertility options after vasectomy: a cost-effectiveness analysis, *Fertil Steril* 67:133, 1997.
558. **Schlegel PN**, Is assisted reproduction the optimal treatment for varicocele-associated male infertility? A cost-effectiveness analysis, *Urology* 49:83, 1997.
559. **Donovan JF Jr, DiBaise M, Sparks AE, Kessler J, Sandlow JI**, Comparison of microscopic epididymal sperm aspiration and intracytoplasmic sperm injection/in-vitro fertilization with repeat microscopic reconstruction following vasectomy: is second attempt vas reversal worth the effort? *Hum Reprod* 13:387, 1998.
560. **Kolettis PN, D'Amico AM, Box L, Burns JR**, Outcomes for vasovasostomy with bilateral intravasal azoospermia, *J Androl* 24:22, 2003.
561. **Matthews GJ, Schlegel PN, Goldstein M**, Patency following microsurgical vasoepididymostomy and vasovasostomy: temporal considerations, *J Urol* 154:2070, 1995.
562. **Goldstein M, Li PS, Matthews GJ**, Microsurgical vasovasostomy: the microdot technique of precision suture placement, *J Urol* 159:188, 1998.
563. **Kolettis PN, Woo L, Sandlow JI**, Outcomes of vasectomy reversal performed for men with the same female partners, *Urology* 61:1221, 2003.
564. **Kolettis PN, Sabanegh ES, D'Amico AM, Box L, Sebesta M, Burns JR**, Outcomes for vasectomy reversal performed after obstructive intervals of at least 10 years, *Urology* 60:885, 2002.
565. **Fuchs EF, Burt RA**, Vasectomy reversal performed 15 years or more after vasectomy: correlation of pregnancy outcome with partner age and with pregnancy results of in vitro fertilization with intracytoplasmic sperm injection, *Fertil Steril* 77:516, 2002.
566. **Paick JS, Park JY, Park DW, Park K, Son H, Kim SW**, Microsurgical vasovasostomy after failed vasovasostomy, *J Urol* 169:1052, 2003.
567. **Hibi H, Yamada Y, Honda N, Fukatsu H, Katsuno S, Ohshima S, Yamamoto M**, Microsurgical vasoepididymostomy with sperm cryopreservation for future assisted reproduction, *Int J Urol* 7:435, 2000.
568. **Chan PT, Brandell RA, Goldstein M**, Prospective analysis of outcomes after microsurgical intussusception vasoepididymostomy, *BJU Int* 96:598, 2005.
569. **Schiff J, Chan P, Li PS, Finkelberg S, Goldstein M**, Outcome and late failures compared in 4 techniques of microsurgical vasoepididymostomy in 153 consecutive men, *J Urol* 174:651, 2005.
570. **Glazier DB, Marmar JL, Mayer E, Gibbs M, Corson SL**, The fate of cryopreserved sperm acquired during vasectomy reversals, *J Urol* 161:463, 1999.
571. **Pryor JP, Hendry WF**, Ejaculatory duct obstruction in subfertile males: analysis of 87 patients, *Fertil Steril* 56:725, 1991.

572. **Turek PJ**, Seminal vesicle and ejaculatory duct surgery, In: Graham SD Jr, ed. Glenn's Urologic Surgery, Lippincott-Raven, Philadelphia, 1998, p. 477.
573. **Cornel EB, Dohle GR, Meuleman EJ**, Transurethral deroofing of midline prostatic cyst for subfertile men, *Hum Reprod* 14:2297, 1999.
574. **Schroeder-Printzen I, Ludwig M, Kohn F, Weidner W**, Surgical therapy in infertile men with ejaculatory duct obstruction: technique and outcome of a standardized surgical approach, *Hum Reprod* 15:1364, 2000.
575. **Purohit RS, Wu DS, Shinohara K, Turek PJ**, A prospective comparison of 3 diagnostic methods to evaluate ejaculatory duct obstruction, *J Urol* 171:232, 2004.
576. **Kadioglu A, Cayan S, Tefekli A, Orhan I, Engin G, Turek PJ**, Does response to treatment of ejaculatory duct obstruction in infertile men vary with pathology? *Fertil Steril* 76:138, 2001.
577. **Paduch DA, Niedzielski J**, Repair versus observation in adolescent varicocele: a prospective study, *J Urol* 158:1128, 1997.
578. **Sigman M, Jarow JP**, Ipsilateral testicular hypotrophy is associated with decreased sperm counts in infertile men with varicoceles, *J Urol* 158:605, 1997.
579. **Chehval MJ, Purcell MH**, Deterioration of semen parameters over time in men with untreated varicocele: evidence of progressive testicular damage, *Fertil Steril* 57:174, 1992.
580. **Witt MA, Lipshultz LI**, Varicocele: a progressive or static lesion? *Urology* 42:541, 1993.
581. **Matthews GJ, Matthews ED, Goldstein M**, Induction of spermatogenesis and achievement of pregnancy after microsurgical varicocelectomy in men with azoospermia and severe oligoasthenospermia, *Fertil Steril* 70:71, 1998.
582. **Kim ED, Leibman BB, Grinblat DM, Lipshultz LI**, Varicocele repair improves semen parameters in azoospermic men with spermatogenic failure, *J Urol* 162:737, 1999.
583. **Goldstein M, Gilbert BR, Dicker AP, Dwosh J, Gnecco C**, Microsurgical inguinal varicocelectomy with delivery of the testis: an artery and lymphatic sparing technique, *J Urol* 148:1808, 1992.
584. **Schlesinger MH, Wilets IF, Nagler HM**, Treatment outcome after varicocelectomy. A critical analysis, *Urol Clin North Am* 21:517, 1994.
585. **Steckel J, Dicker AP, Goldstein M**, Relationship between varicocele size and response to varicocelectomy, *J Urol* 149:769, 1993.
586. **Evers JL, Collins JA, Vandekerckhove P**, Surgery or embolisation for varicocele in subfertile men, *Cochrane Database Syst Rev* (1):CD000479, 2001.
587. **Evers JL, Collins JA**, Assessment of efficacy of varicocele repair for male subfertility: a systematic review, *Lancet* 361:1849, 2003.
588. **Grasso M, Lania C, Castelli M, Galli L, Franzoso F, Rigatti P**, Low-grade left varicocele in patients over 30 years old: the effect of spermatic vein ligation on fertility, *BJU Int* 85:305, 2000.
589. **Madgar I, Weissenberg R, Lunenfeld B, Karasik A, Goldwasser B**, Controlled trial of high spermatic vein ligation for varicocele in infertile men, *Fertil Steril* 63:120, 1995.
590. **Nieschlag E, Hertle L, Fishedick A, Abshagen K, Behre HM**, Update on treatment of varicocele: counselling as effective as occlusion of the vena spermatica, *Hum Reprod* 13:2147, 1998.
591. **Cayan S, Erdemir F, Ozbey I, Turek PJ, Kadioglu A, Tellaloglu S**, Can varicocelectomy significantly change the way couples use assisted reproductive technologies? *J Urol* 167:1749, 2002.
592. **Shin D, Lemack GE, Goldstein M**, Induction of spermatogenesis and pregnancy after adult orchiopexy, *J Urol* 158:2242, 1997.
593. **Ohl DA, Sonksen J, Menge AC, McCabe M, Keller LM**, Electroejaculation versus vibratory stimulation in spinal cord injured men: sperm quality and patient preference, *J Urol* 157:2147, 1997.
594. **Palermo G, Joris H, Devroey P, Van Steirteghem AC**, Pregnancies after intracytoplasmic injection of a single spermatozoon into an oocyte, *Lancet* 340:17, 1992.
595. **Van Steirteghem AC, Nagy Z, Joris H, Liu J, Staessen C, Smits J, Wisanto A, Devroey P**, High fertilization and implantation rates after intracytoplasmic sperm injection, *Hum Reprod* 8:1061, 1993.
596. **Centers for Disease Control and Prevention**, 2015 Assisted Reproductive Technology Success Rates. National Summary and Fertility Clinic Reports, U.S. Department of Health and Human Services, Atlanta, 2017.

597. **Matthews GJ, Goldstein M**, A simplified method of epididymal sperm aspiration, *Urology* 47:123, 1996.
598. **Nudell DM, Conaghan J, Pedersen RA, Givens CR, Schriock ED, Turek PJ**, The mini-micro-epididymal sperm aspiration for sperm retrieval: a study of urological outcomes, *Hum Reprod* 13:1260, 1998.
599. **Janzen N, Goldstein M, Schlegel PN, Palermo GD, Rosenwaks Z, Hariprashad J**, Use of electively cryopreserved microsurgically aspirated epididymal sperm with IVF and intracytoplasmic sperm injection for obstructive azoospermia, *Fertil Steril* 74:696, 2000.
600. **Shrivastav P, Nadkarni P, Wensvoort S, Craft I**, Percutaneous epididymal sperm aspiration for obstructive azoospermia, *Hum Reprod* 9:2058, 1994.
601. **Craft IL, Khalifa Y, Boulos A, Pelekanos M, Foster C, Tsirigotis M**, Factors influencing the outcome of in-vitro fertilization with percutaneous aspirated epididymal spermatozoa and intracytoplasmic sperm injection in azoospermic men, *Hum Reprod* 10:1791, 1995.
602. **Tournaye H, Camus M, Goossens A, Liu J, Nagy P, Silber S, Van Steirteghem AC, Devroey P**, Recent concepts in the management of infertility because of non-obstructive azoospermia, *Hum Reprod* 10(Suppl 1):115, 1995.
603. **Schlegel PN, Palermo GD, Goldstein M, Menendez S, Zaninovic N, Veeck LL, Rosenwaks Z**, Testicular sperm extraction with intracytoplasmic sperm injection for nonobstructive azoospermia, *Urology* 49:435, 1997.
604. **Craft I, Tsirigotis M**, Simplified recovery, preparation and cryopreservation of testicular spermatozoa, *Hum Reprod* 10:1623, 1995.
605. **Schlegel PN**, Testicular sperm extraction: microdissection improves sperm yield with minimal tissue excision, *Hum Reprod* 14:131, 1999.
606. **Dardashti K, Williams RH, Goldstein M**, Microsurgical testis biopsy: a novel technique for retrieval of testicular tissue, *J Urol* 163:1206, 2000.
607. **Silber SJ, van Steirteghem A, Nagy Z, Liu J, Tournaye H, Devroey P**, Normal pregnancies resulting from testicular sperm extraction and intracytoplasmic sperm injection for azoospermia due to maturation arrest, *Fertil Steril* 66:110, 1996.
608. **Chen SU, Ho HN, Chen HF, Tsai TC, Lee TY, Yang YS**, Fertilization and embryo cleavage after intracytoplasmic spermatid injection in an obstructive azoospermic patient with defective spermiogenesis, *Fertil Steril* 66:157, 1996.
609. **Su LM, Palermo GD, Goldstein M, Veeck LL, Rosenwaks Z, Schlegel PN**, Testicular sperm extraction with intracytoplasmic sperm injection for nonobstructive azoospermia: testicular histology can predict success of sperm retrieval, *J Urol* 161:112, 1999.
610. **Chan PT, Palermo GD, Veeck LL, Rosenwaks Z, Schlegel PN**, Testicular sperm extraction combined with intracytoplasmic sperm injection in the treatment of men with persistent azoospermia postchemotherapy, *Cancer* 92:1632, 2001.
611. **Damani MN, Master V, Meng MV, Burgess C, Turek P, Oates RD**, Postchemotherapy ejaculatory azoospermia: fatherhood with sperm from testis tissue with intracytoplasmic sperm injection, *J Clin Oncol* 20:930, 2002.
612. **Revel A, Haimov-Kochman R, Porat A, Lewin A, Simon A, Laufer N, Gino H, Meirou D**, In vitro fertilization-intracytoplasmic sperm injection success rates with cryopreserved sperm from patients with malignant disease, *Fertil Steril* 84:118, 2005.
613. **Palermo GD, Schlegel PN, Sills ES, Veeck LL, Zaninovic N, Menendez S, Rosenwaks Z**, Births after intracytoplasmic injection of sperm obtained by testicular extraction from men with nonmosaic Klinefelter's syndrome, *N Engl J Med* 338:588, 1998.
614. **Kurinczuk JJ, Bower C**, Birth defects in infants conceived by intracytoplasmic sperm injection: an alternative interpretation, *Br Med J* 315:1260, 1997.
615. **Hansen M, Bower C, Milne E, de Klerk N, Kurinczuk JJ**, Assisted reproductive technologies and the risk of birth defects—a systematic review, *Hum Reprod* 20:328, 2005.
616. **Fraga CG, Motchnik PA, Wyrobek AJ, Rempel DM, Ames BN**, Smoking and low antioxidant levels increase oxidative damage to sperm DNA, *Mutat Res* 351:199, 1996.

617. **Ji BT, Shu XO, Linet MS, Zheng W, Wacholder S, Gao YT, Ying DM, Jin F**, Paternal cigarette smoking and the risk of childhood cancer among offspring of nonsmoking mothers, *J Natl Cancer Inst* 89:238, 1997.
618. **Sun JG, Jurisicova A, Casper RF**, Detection of deoxyribonucleic acid fragmentation in human sperm: correlation with fertilization in vitro, *Biol Reprod* 56:602, 1997.
619. **Bonduelle M, Wilikens A, Buysse A, Van Assche E, Wisanto A, Devroey P, Van Steirteghem AC, Liebaers I**, Prospective follow-up study of 877 children born after intracytoplasmic sperm injection (ICSI), with ejaculated epididymal and testicular spermatozoa and after replacement of cryopreserved embryos obtained after ICSI, *Hum Reprod* 11(Suppl 4):131, 1996.
620. **Bonduelle M, Legein J, Buysse A, Van Assche E, Wisanto A, Devroey P, Van Steirteghem AC, Liebaers I**, Prospective follow-up study of 423 children born after intracytoplasmic sperm injection, *Hum Reprod* 11:1558, 1996.
621. **Van Golde R, Boada M, Veiga A, Evers J, Geraedts J, Barri P**, A retrospective follow-up study on intracytoplasmic sperm injection, *J Assist Reprod Genet* 16:227, 1999.
622. **Hansen M, Kurinczuk JJ, Bower C, Webb S**, The risk of major birth defects after intracytoplasmic sperm injection and in vitro fertilization, *N Engl J Med* 346:725, 2002.
623. **Lie RT, Lyngstadaas A, Orstavik KH, Bakketeig LS, Jacobsen G, Tanbo T**, Birth defects in children conceived by ICSI compared with children conceived by other IVF-methods; a meta-analysis, *Int J Epidemiol* 34:696, 2005.
624. **Wennerholm UB, Bergh C, Hamberger L, Lundin K, Nilsson L, Wikland M, Kallen B**, Incidence of congenital malformations in children born after ICSI, *Hum Reprod* 15:944, 2000.
625. **Allen VM, Wilson RD, Cheung A**, Pregnancy outcomes after assisted reproductive technology, *J Obstet Gynaecol Can* 28:220, 2006.

# Induction of Ovulation

Although it seems commonplace today, indeed even routine, the ability to induce ovulation and attain pregnancy in anovulatory infertile women remains one of the greatest achievements of reproductive endocrinology. Once limited to clomiphene citrate, the therapeutic armamentarium for ovulation induction now includes a wide variety of agents.

Ovulatory disorders can be identified in 18–25% of infertile women.<sup>1</sup> When anovulation is the only infertility factor, the prognosis for pregnancy generally is quite good because modern ovulation induction strategies are highly effective. When a specific cause for anovulation can be identified, treatment often restores normal cycle fecundity. Even when no specific cause can be found, as in most anovulatory women, empiric treatments with low costs and risks usually succeed. When those fail, other more complex forms of treatment are effective. One way or another, almost all anovulatory infertile women can be induced to ovulate. Unfortunately, many still do not conceive, often because there are other coexisting infertility factors.

Clinicians caring for infertile couples must have a thorough understanding of the methods for treatment of anovulatory infertility. This chapter reviews the principles that guide the choice of treatment, the results achieved with different therapies, and their associated risks.



# DIAGNOSIS OF ANOVULATION

---

The diagnosis of anovulation generally is not difficult to establish. **Women with irregular, unpredictable, or infrequent menses do not require specific diagnostic tests to prove what is already obvious.** When anovulation is suspected but uncertain, a variety of methods can be used to evaluate ovulatory function, as discussed in [Chapter 25](#) and summarized briefly here.

Ovulatory cycles typically are associated with a classic “biphasic” basal body temperature (BBT) pattern that is not difficult to recognize, when present.<sup>2</sup> **BBT recordings having no sustained interval of temperature elevation preceding the onset of menses strongly suggest anovulation.** Biphasic recordings exhibiting a short luteal phase (onset of menses <12 days after the midcycle rise in BBT) suggest a subtle, but still important, form of ovulatory dysfunction. Although uncommon, BBT recordings are not clearly biphasic in some ovulatory women. Since BBT cannot reliably define the time of ovulation and can become tedious, it is not the method of choice for evaluating ovulatory function for most infertile women.<sup>3</sup>

**A serum progesterone measurement is the simplest, most common, objective, and reliable test of ovulatory function, as long as it is appropriately timed. A progesterone concentration less than 3 ng/mL implies anovulation, except when drawn immediately after ovulation or just before the onset of menses, when lower levels naturally might be expected.**<sup>4,5</sup> A normal ovulatory cycle is 25–35 days in duration and exhibits a luteal phase lasting approximately 14 days. **Ideally, the serum progesterone level should be drawn approximately 1 week before the expected onset of menses, when the concentration is at or near its peak. Contrary to popular belief and practice, cycle day 21 is not always the best time to measure the serum progesterone concentration and the threshold level indicating ovulation is not 10 ng/mL.** Cycle day 21 is a good choice for women with cycles lasting approximately 28 days but a poor choice for women with 35-day cycles. A serum progesterone concentration greater than 10 ng/mL suggests normal luteal function but not when the luteal phase is grossly short, and a level less than 10 ng/mL can be quite normal, because progesterone is secreted by the corpus luteum in distinct pulses, temporally linked to pulsatile luteinizing hormone (LH) secretion<sup>6</sup>; random sampling can coincide with a transient nadir in serum levels. **If the menses does not commence 7 days after a serum progesterone reading of less than 3 ng/mL, it may be reasonable to repeat the test.**

Other simple tests of ovulation include monitoring urinary LH excretion. This has been simplified by the wide availability of home urine LH kits that are designed to

detect a high LH value at the time of the LH surge. More sophisticated test available for home use also includes a measure of rising estrogen production preceding the LH surge. Serial transvaginal ultrasonography can be useful once ovulation has been achieved but is unnecessary and not always accurate for the diagnosis of anovulation. Ruptured follicles can refill with fluid, and a nondominant follicle that has progressed in size can be mistaken for the missing follicle.

# CLASSIFICATION OF OVULATORY DISORDERS

---

After evaluation for the causes of anovulation is completed, virtually all women can be classified according to the criteria adopted by the World Health Organization (WHO).<sup>7</sup> Hyperprolactinemic anovulation is considered as a fourth and specific category.

# **WHO Group I: Hypogonadotropic Hypogonadal Anovulation**

The group accounts for approximately 5–10% of anovulatory women and includes those with low or low-normal serum follicle-stimulating hormone (FSH) concentrations and low serum estradiol levels, due to absent or abnormal hypothalamic gonadotropin-releasing hormone (GnRH) secretion or pituitary insensitivity to GnRH. Examples include women with hypothalamic amenorrhea relating to physical, nutritional, or emotional stress; weight loss; excessive exercise; anorexia nervosa and its variants; Kallmann syndrome; and isolated gonadotropin deficiency. Women in the group may require hypothalamic-pituitary imaging to exclude a mass lesion.

# **WHO Group II: Normogonadotropic Normoestrogenic Anovulation**

This group is the largest, including 75–85% of anovulatory women, and is characterized by normal serum FSH and estradiol levels and normal or elevated LH concentrations.<sup>8</sup> The most common examples are women with polycystic ovary syndrome (PCOS), some of whom ovulate at least occasionally. Women with PCOS should be assessed for cardiovascular disease risk factors and glycaemic status.<sup>9</sup>

# **WHO Group III: Hypergonadotropic Anovulation**

The group accounts for approximately 10–20% of anovulatory women and includes those with elevated serum FSH and low AMH concentrations; most, but not all, have amenorrhea. The classic example is premature ovarian insufficiency, due to follicular depletion, and few respond to treatment aimed at ovulation induction.

# Hyperprolactinemic Anovulation

Approximately 5–10% of anovulatory women have hyperprolactinemia, which inhibits gonadotropin secretion. Consequently, serum FSH concentrations generally are low or low-normal, and serum estradiol levels also tend to be relatively low. Most hyperprolactinemic women have oligomenorrhea or amenorrhea. When hyperprolactinemia cannot be attributed confidently to coexisting hypothyroidism or to medications, hypothalamic-pituitary imaging is indicated to exclude a mass lesion.

# PRETREATMENT EVALUATION AND TREATMENT

---

The causes of anovulation are many and varied. Thyroid disease, hyperprolactinemia, adrenal disease, pituitary or ovarian tumors, eating disorders, extremes of weight loss or exercise, PCOS, and obesity all are commonly associated with ovulatory dysfunction. Treatment should be directed at the underlying cause, when that can be determined, because specific treatment is more likely to succeed and some conditions can have longer-term health consequences if not recognized and treated.

**All anovulatory women deserve at least some preliminary evaluation, both to exclude important pathology that may require medical attention before ovulation induction begins and to identify the most likely successful form of treatment.** Chapter 10 considers the causes and management of amenorrhea and galactorrhea. Chapters 11 and 12 discuss the pathophysiology and treatment of PCOS and hirsutism. Chapter 15 describes the evaluation of abnormal uterine bleeding. At a minimum, anovulatory women should be screened for thyroid disorders (serum TSH) and hyperprolactinemia (serum prolactin) because both require further evaluation and specific treatment.<sup>10,11,12</sup> Depending on the menstrual history, endometrial sampling also merits consideration, because chronic anovulation is associated with increased risk for endometrial hyperplasia. Persistently thick endometrium, prolonged amenorrhea, abnormal vaginal bleeding, or excess weight should require investigation for endometrial cancer in women with PCOS.<sup>9</sup>

**Glycemic status should be assessed at baseline in all women with PCOS. In high-risk patients, that is, with a BMI greater than 25 kg/m<sup>2</sup>, history of impaired fasting glucose, impaired glucose tolerance or gestational diabetes, family history of diabetes mellitus type 2, hypertension, or high-risk ethnicity, oral glucose tolerance test is recommended.<sup>9</sup> Even though OGTT is the preferred method of testing for impaired glucose tolerance and early type 2 diabetes, fasting plasma glucose or HbA1C levels can suffice for others.<sup>9</sup> When OGTT is done, 2 hours after a 75 g oral glucose load, glucose concentrations between 140 and 199 mg/dL indicate impaired glucose tolerance and levels of 200 mg/dL or greater indicate non-insulin-dependent diabetes.**

Anovulation offers an obvious potential explanation for infertility but often is not the only infertility factor. **Before ovulation induction begins, a screening semen analysis is prudent because male factors are an important contributing cause in 20–40% of infertile couples.<sup>13</sup> Early recognition of a significant coexisting male factor helps to avoid wasted time, effort, expense, and associated frustrations.**



Additional preliminary evaluation with hysterosalpingography (HSG) or transvaginal ultrasonography merits serious consideration, particularly in women with a history of previous pelvic infection or surgery, ectopic pregnancy, inflammatory bowel disease, pelvic pain or other symptoms of endometriosis, or an abnormal physical examination. In the absence of such risk factors, the likelihood of tubal disease is low and HSG can be deferred safely in young women and those who do not require complicated and costly forms of ovulation induction. In older women with a narrowing window of opportunity, it is generally wise to evaluate objectively all relevant infertility factors before treatment begins to ensure that time is used to the best possible advantage. In women who require ovulation induction with exogenous gonadotropins, the associated costs, logistics, and risks also justify a thorough preliminary evaluation. **Preliminary HSG and transvaginal ultrasonography are recommended when the medical history or physical examination raises suspicion for coexisting uterine or tubal infertility factors, for women over age 35, and when ovulation induction requires treatment with exogenous gonadotropins.** Laparoscopy and hysteroscopy are unnecessary for most women but certainly appropriate for those with an abnormal HSG or signs or symptoms of pelvic disease.

Lifestyle management for weight loss is recommended for PCOS patients with a BMI greater than 25 kg/m<sup>2</sup>. **Even modest weight loss (5–10% of body weight) often restores ovulatory cycles in obese anovulatory women with PCOS.**<sup>14,15,16,17,18,19,20</sup> In overweight and obese women with PCOS, unless age-related infertility is a concern, intensive lifestyle modification, including hypocaloric diet and exercise, with or without behavioral interventions, may be the first-line treatment for 3–6 months, to determine whether ovulation is resumed.<sup>9</sup> At a minimum, weight loss can increase sensitivity to ovulation-inducing drugs and decrease the complexity of treatment required. In one study, 60 of 67 obese anovulatory women (90%) who lost an average of 10 kg/m<sup>2</sup> in a diet and exercise program resumed spontaneous ovulation and 52 (78%) ultimately achieved pregnancy, 18 (27%) without other interventions.<sup>20</sup> In another study, 149 infertile women with PCOS were randomly allocated to (1) continuous oral contraceptive pills (OCP); (2) lifestyle modification consisting of caloric restriction with meal replacements, weight loss medication (either sibutramine or orlistat), and increased physical activity to promote a 7% weight loss; or (3) combined treatment with both OCP and lifestyle modification, for 16 weeks prior to four cycles of ovulation induction with clomiphene and timed intercourse.<sup>21</sup> Women receiving lifestyle modification or combined lifestyle modification with OCP achieved significant weight reduction (–6.2% and –6.4%, respectively) and had significantly higher cumulative ovulation rates than women receiving OCP (60%, 67%, and 46%, respectively).<sup>21</sup> Compared to similar women who received clomiphene right away in

another randomized trial,<sup>22</sup> women receiving lifestyle modification in the aforementioned trial achieved significantly higher cumulative ovulation (lifestyle, RR = 1.4; 95% CI = 1.1–1.7; combined, RR = 1.4; 95% CI = 1.2–1.8) and significantly better live birth rates (lifestyle, RR = 2.5; 95% CI = 1.3–4.7 and combined, RR = 2.5; 95% CI = 1.3–4.8).<sup>22,23</sup>

Bariatric surgery can be considered as a second-line treatment option when significant obesity (BMI > 35 kg/m<sup>2</sup>) and anovulation are resistant to lifestyle intervention and/or pharmacotherapy, especially in the presence of obesity-related comorbidities.<sup>9,24</sup> Even though bariatric surgery improves anovulation, hirsutism, insulin resistance, sexual activity, and libido, whether maternal and fetal outcomes are improved is uncertain.<sup>25,26</sup> A 2016 meta-analysis, including 13 case series with 2,130 PCOS patients who underwent bariatric surgery, reported that 12 months after surgery, the incidence of PCOS decreased to 6.8% from 45.6%, menstrual irregularity to 7.7% from 56.2%, and hirsutism to 38.6% from 67.0%.<sup>25</sup> The incidence of preoperative infertility was 18.2%, which significantly decreased to 4.3% at study end.<sup>25</sup> A 2017 meta-analysis corroborated these findings and furthermore reported 96% (CI = 88–100%) resolution rate for PCOS among 82 severely obese patients.<sup>27</sup> Bariatric surgery can cause malabsorption and eating disorders, which may adversely affect maternal and neonatal health. Risks of small-for-gestational-age babies, preterm delivery, and, possibly, neonatal mortality seem to increase after bariatric surgery. Therefore, it is recommended to avoid pregnancy during rapid weight loss and for at least 12 months after bariatric surgery. In sum, bariatric surgery is considered an experimental therapy for infertility associated with PCOS.<sup>9</sup>

# CLOMIPHENE CITRATE

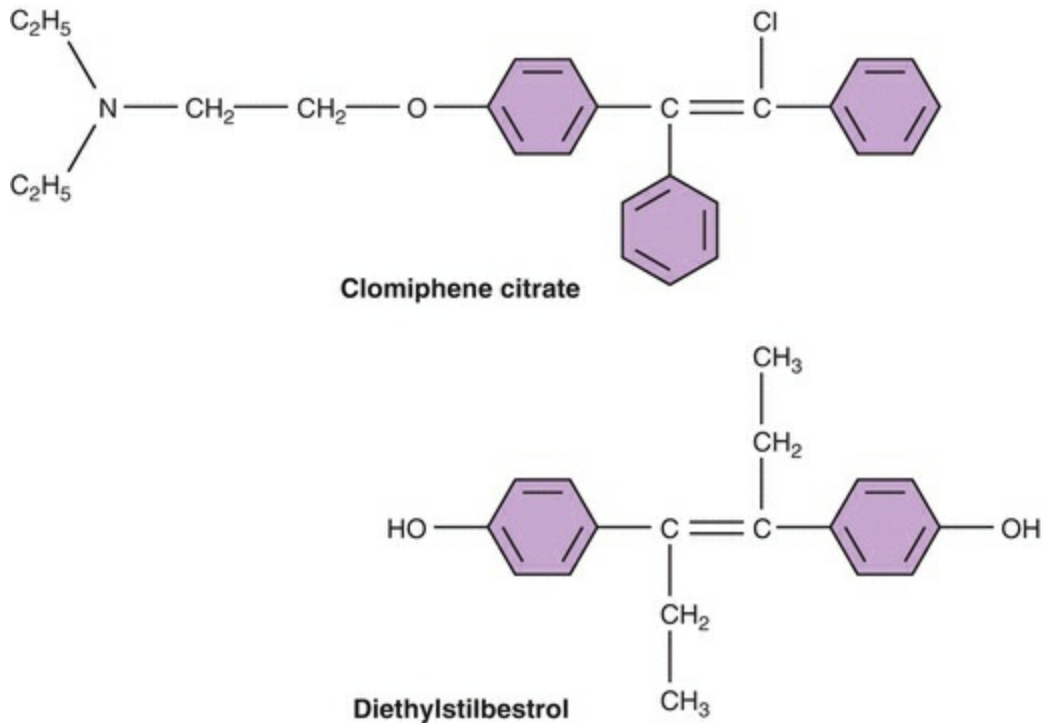
---

Clomiphene citrate was first synthesized in 1956, introduced for clinical trials in 1960, and approved for clinical use in the United States in 1967.<sup>28,29</sup> In early clinical trials, 60–80% of anovulatory women treated with clomiphene achieved ovulation and half of those who ovulated also conceived.<sup>28,29,30</sup> The collected clinical experience gained in the years since remains consistent with those early observations.

# Pharmacology and Mechanism of Action

Clomiphene is a nonsteroidal triphenylethylene derivative that acts as a selective estrogen receptor modulator (SERM), having both estrogen agonist and antagonist properties.<sup>31</sup> However, in almost all clinical circumstances, clomiphene acts purely as an antagonist or antiestrogen; its weak estrogenic actions are clinically apparent only when endogenous estrogen levels are very low. Clomiphene is cleared through the liver and excreted in the stool; approximately 85% is eliminated within a week, but traces can remain in the circulation for a longer time.<sup>32</sup> Clomiphene is a racemic mixture of two different stereoisomers, enclomiphene (62%, originally known as cis-clomiphene) and zuclomiphene (38%, originally known as trans-clomiphene).<sup>31,33</sup> Enclomiphene is the more potent isomer and the one responsible for its ovulation-inducing actions.<sup>31,34</sup> The half-life of enclomiphene is relatively short, so serum concentrations rise and fall quickly during and after treatment.<sup>32,35</sup> Zuclomiphene is cleared much more slowly; serum levels remain detectable for weeks after a single dose<sup>32</sup> and may even accumulate gradually over a series of cycles, but there is no evidence that residual zuclomiphene has any important clinical effects or consequences.<sup>35</sup>

Structural similarity to estrogen allows clomiphene to compete with endogenous estrogen for nuclear estrogen receptors at sites throughout the reproductive system. However, unlike estrogen, clomiphene binds to nuclear estrogen receptors for an extended interval of time and thereby depletes receptor concentrations by interfering with receptor recycling.<sup>31</sup> At the hypothalamic level, estrogen receptor depletion prevents accurate interpretation of circulating estrogen levels; circulating estrogen levels are perceived as lower than they truly are. **Reduced negative estrogen feedback triggers normal compensatory mechanisms that alter the pattern of GnRH secretion and stimulate increased pituitary gonadotropin release, which, in turn, drives ovarian follicular development.** In the pituitary, clomiphene also may increase the sensitivity of gonadotrophs to GnRH stimulation (**Figure 27.1**).<sup>36</sup>



**FIGURE 27.1**

When administered to already ovulatory women, clomiphene increases GnRH pulse frequency.<sup>37</sup> In anovulatory women with PCOS who already exhibit an increased GnRH pulse frequency, clomiphene increases only pulse amplitude.<sup>38</sup> Serum levels of both FSH and LH rise during clomiphene treatment and fall again soon after the typical 5-day course of therapy is completed.<sup>39</sup> In successful treatment cycles, one or more follicles emerge and grow to maturity. In parallel, serum estrogen levels rise progressively, ultimately triggering an LH surge and ovulation. In sum, clomiphene works primarily by stimulating the normal endocrine mechanisms that define the hypothalamic-pituitary-ovarian feedback axis. The importance of other effects it may have on insulin-like growth factors (decrease in IGF-I concentrations) and sex hormone-binding globulin (increase in serum levels) is uncertain.<sup>40,41</sup>

## Peripheral Actions

In addition to its desirable central actions, clomiphene can exert less desirable antiestrogenic effects at peripheral sites in the reproductive system, which some have suggested might explain the difference between ovulation and pregnancy rates achieved with clomiphene treatment. **Adverse effects of clomiphene on the endocervix, the endometrium, the ovary, the ovum, and the embryo have been described, but there is no compelling evidence to indicate that such effects have important clinical consequences in most women.**

On balance, the weight of evidence from controlled trials suggests that the quality and quantity of **cervical mucus production** can be decreased in clomiphene treatment cycles. Whereas some have observed no significant changes in mucus characteristics during treatment,<sup>42</sup> others have found clomiphene has dose-dependent adverse effects.<sup>43,44</sup> The conflicting results have several possible explanations. The effect may be more apparent when the interval between the end of treatment and ovulation is short.<sup>43</sup> The effect might often be negated by higher serum estradiol levels resulting from clomiphene-induced multifollicular development.<sup>45</sup> It also is possible that some individuals may be more sensitive to the effect.<sup>46</sup> Regardless, any adverse effect that clomiphene may have on cervical mucus does not prevent pregnancy ([Chapter 25](#)). In recent years, even the evaluation of cervical mucus has all but disappeared from clinical practice because controlled trials have demonstrated that postcoital testing (the traditional test of cervical factors) has little or no predictive value<sup>47,48</sup> and because modern advanced treatment regimens for persistent infertility now routinely incorporate intrauterine insemination (IUI), which bypasses the cervix altogether.<sup>49,50</sup>

Impaired **endometrial growth** also has been reported in clomiphene-treated women. However, preovulatory endometrial thickness in clomiphene-induced cycles remains well within the range normally observed in spontaneous ovulatory cycles in the large majority of women.<sup>49,51,52,53,54,55,56</sup> Other subtle differences in endometrial morphology have been attributed to the effects of clomiphene, but their clinical relevance, if any, is uncertain.<sup>57,58</sup> It is likely that clomiphene inhibits endometrial growth, at least in some women, for the same reasons that it may inhibit cervical mucus production, but the same caveats apply; the effect is inconsistent, may be offset by the higher estrogen levels in clomiphene-induced cycles, and probably has little clinical importance, except perhaps in those individuals exhibiting grossly poor endometrial growth (peak preovulatory thickness <5–6 mm).

Clomiphene does not appear to have any clinically relevant direct effects on the **ovary** or **embryo**. Although clomiphene can inhibit steroid hormone production by

cultured avian,<sup>59</sup> ovine,<sup>60</sup> and human granulosa/luteal cells in vitro,<sup>61</sup> serum estrogen and progesterone concentrations in clomiphene-induced cycles are typically higher, not lower, than in spontaneous ovulatory cycles. Adverse effects on mouse ovum fertilization and embryo development have been observed in vitro,<sup>62</sup> but studies in women indicate that serum concentrations of enclomiphene and zuclomiphene never approach the levels required to induce such effects, even after several consecutive treatment cycles.<sup>35</sup>

# Clinical Indications

Before the introduction of aromatase inhibitors, and large randomized controlled trials demonstrating higher live birth rates with letrozole, clomiphene citrate was the traditional drug of choice for ovulation induction in anovulatory infertile women with normal thyroid function, normal serum prolactin levels, and normal endogenous estrogen production, as determined by clinical observations (oligomenorrhea, estrogenic cervical mucus), a serum estradiol determination ( $>$  approximately 40 pg/mL), or a normal menstrual response to a progestin challenge (WHO Group II).<sup>63,64</sup> Although the drug also frequently is used empirically to stimulate multifollicular development in ovulatory women with unexplained infertility (in combination with IUI),<sup>50,65,66,67,68</sup> the focus here is on ovulation induction in anovulatory women; empiric clomiphene and other treatments for unexplained infertility are discussed in detail in [Chapter 25](#).

**Given its mechanism of action, it is not surprising that clomiphene typically is ineffective in women with hypogonadotropic hypogonadism (WHO Group I).** Together, low or low-normal FSH levels and low serum estrogen concentrations indicate that the hypothalamic-pituitary-ovarian axis is not functioning normally in women with hypothalamic amenorrhea; if it were, FSH levels would be high because estrogen concentrations are low. If low endogenous estrogen concentrations cannot stimulate increased FSH secretion, there is little reason to think that a clomiphene-induced decrease in the level of negative estrogen feedback will succeed, and it rarely does. Alternative treatments that directly stimulate the pituitary (pulsatile exogenous GnRH) or the ovary (exogenous gonadotropins) usually are required.

Because the corpus luteum derives from the ovulatory follicle, its functional capacity depends, in part, on the quality of preovulatory follicular development. Logically, inadequate follicular development can be expected to cause or predispose to poor luteal function, if ovulation still occurs. Indeed, the most obvious example of poor luteal function, a short luteal phase, is associated with abnormally low follicular phase FSH levels.<sup>69,70</sup> Consequently, clomiphene could be both a logical and effective choice for treatment.<sup>71,72,73,74</sup> Progesterone levels typically are higher in clomiphene-induced ovulatory cycles than in normal spontaneous cycles, likely because preovulatory follicular development is optimized and because treatment often results in more than one corpus luteum.<sup>74,75</sup>

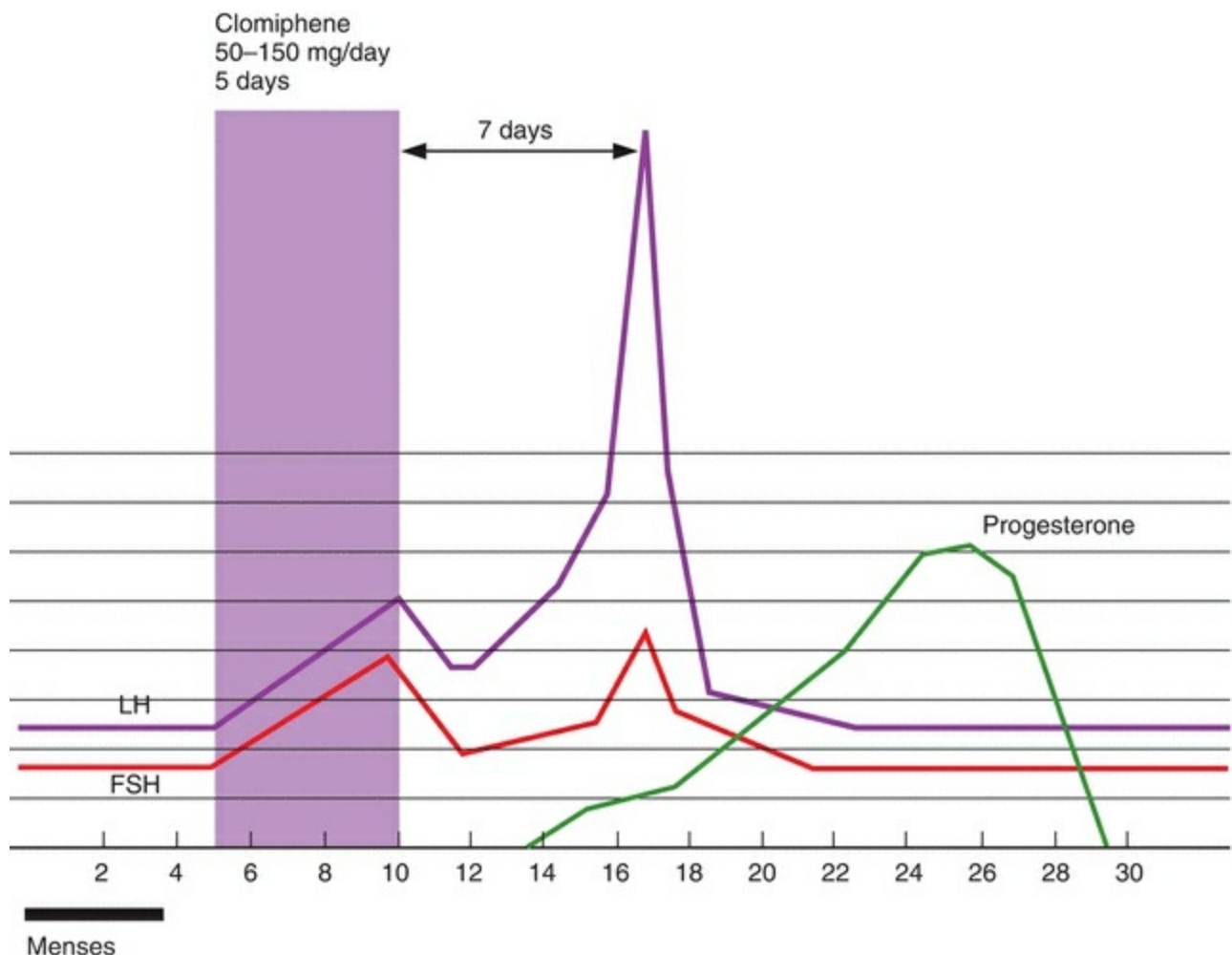
Clomiphene citrate treatment is generally limited to women with demonstrated ovulatory dysfunction but has also been offered to normally ovulating women whose infertility remains unexplained, particularly when they are young and infertility is of short duration, and those unwilling or unable to pursue more aggressive treatments. The putative efficacy of clomiphene treatment in women with unexplained infertility has



been attributed to optimizing follicular development or to the “superovulation” of more than a single ovum. However, clomiphene alone does not seem to significantly improve live birth rates or time to pregnancy compared to expectant management in unexplained infertility.<sup>65</sup> **Empiric clomiphene treatment for unexplained infertility is most effective when combined with IUI, in an effort to increase the numbers of both ova and sperm (Chapter 25).**<sup>50,65,76</sup> **On the contrary, in anovulatory women with PCOS treated with clomiphene, IUI is not superior to timed intercourse, when the semen analysis is within the normal range.**<sup>77</sup>

# Clomiphene Treatment Regimens

Clomiphene is administered orally, typically beginning on the third to fifth day after the onset of a spontaneous or progestin-induced menses. Ovulation and conception rates and pregnancy outcomes are similar when treatment starts anywhere between cycle days 2 and 5.<sup>78</sup> In women with amenorrhea, treatment can begin immediately, without inducing endometrial shedding, if pregnancy has been excluded. Indeed, available evidence suggests that progestin-induced endometrial shedding is associated with a longer treatment cycle, lower conception and live birth rates, and longer time to pregnancy.<sup>79,80</sup> The dose of clomiphene required to induce ovulation correlates with body weight but cannot be predicted confidently for an individual woman.<sup>81,82</sup> Although obese women often require higher doses of clomiphene treatment, the results achieved ultimately are similar to those observed in lean women.<sup>83,84</sup> No clinical or laboratory parameter has proven utility for predicting the dose of clomiphene needed to induce ovulation (**Figure 27.2**).<sup>81,84</sup>



## FIGURE 27.2

Treatment usually starts with a single 50-mg tablet daily for a 5-day interval and, if necessary, increases by 50 mg increments in subsequent cycles until ovulation is achieved. **Most women who respond to clomiphene will respond to either 50 mg (52%) or 100 mg (22%).**<sup>85,86</sup> Lower doses (12.5–25 mg daily) deserve consideration for women who prove highly sensitive to the drug or develop large ovarian cysts that prevent continued treatment.<sup>87</sup> Although not approved by the U.S. Food and Drug Administration, higher doses of clomiphene (150–250 mg daily) sometimes can succeed when lower doses fail (150 mg, 12%; 200 mg 7%; 250 mg 5%).<sup>85,86</sup> We believe that treatment with doses up to 150 mg is reasonable before considering alternatives and recommend against the use of higher doses.<sup>85</sup> Longer durations of clomiphene treatment (7–10 days) can succeed in some women when standard treatment does not and occasionally may be useful when there are no practical alternatives.<sup>82,88,89</sup>

The same methods used for diagnosis of anovulation can be used to evaluate the response to treatment. BBT recordings are simple and inexpensive but can become tedious over time. **A serum progesterone level greater than 3 ng/mL provides reliable evidence that ovulation has occurred**<sup>4,5</sup> **but must be timed appropriately for confident and correct interpretation.** Measuring the serum progesterone concentration between cycle days 22 and 25 will minimize the risk of sampling immediately after ovulation (occurring as late as cycle day 19–20 in cycles lasting up to 35 days) or before menses, when levels less than 3 ng/mL might be observed and misinterpreted. More sophisticated tests of ovulation involving greater costs and logistical demands are unnecessary to determine only if ovulation occurred but may be justified once successful ovulation induction has been achieved.

Commercial test kits can detect the midcycle urinary LH surge and help to determine not only whether ovulation occurred, but when, and to accurately define the length of the luteal phase.<sup>90</sup> **In clomiphene-induced ovulatory cycles in anovulatory women, the LH surge typically occurs 5–12 days after treatment ends, most often on cycle day 16 or 17 when clomiphene is administered on days 5–9.**<sup>91</sup> Ovulation generally occurs 14–26 hours after surge detection and almost always within 48 hours.<sup>90</sup> However, in clinical practice, both false-negative and false-positive results are relatively common.<sup>92,93</sup> An endometrial biopsy yielding secretory endometrium also implies recent ovulation,<sup>94</sup> but the associated costs and discomfort cannot be justified for that purpose alone. Serial transvaginal ultrasonography can demonstrate the size and number of developing follicles, track endometrial growth, and provide presumptive evidence of ovulation<sup>95,96</sup> but is difficult to justify when less complicated and costly methods can

provide the necessary information. Some advocate monitoring at least the first cycle of treatment to identify those who respond excessively.<sup>97</sup> A study comparing fecundity in clomiphene-induced cycles monitored with BBT, urinary LH excretion, or serial transvaginal ultrasonography found no clear advantage for any one of the three methods.<sup>98</sup>

Traditionally, when the serum progesterone concentration reveals persistent anovulation after clomiphene treatment, a progestin is prescribed (e.g., medroxyprogesterone acetate, 5–10 mg daily for 5–7 days) to induce menses before the next cycle begins at a higher dosage. Although effective, the sequence takes time and several months may pass before a patient is proven unresponsive to clomiphene. A “stair-step” treatment protocol is an alternative that can shorten the time required to achieve ovulation and to identify those who require different treatment. The regimen involves treatment with clomiphene (50 mg) on cycle days 5–9 after a spontaneous or induced menses, ultrasonography on days 11–14, immediate treatment at the next higher-dose level (100 mg) if no dominant follicle ( $\geq 15$  mm) has emerged, repeated ultrasonography 1 week later, and, if still no dominant follicle is observed, immediate treatment at the highest dose level (150 mg) and ultrasonography again 1 week later.<sup>99</sup> Stair-step protocol is associated with shorter time to ovulation, higher rate of ovulation, and similar pregnancy rates, albeit with higher incidence of mild side effects.<sup>80,100,101</sup>

In the past, monthly pelvic examinations to exclude residual ovarian enlargement were recommended before each new clomiphene treatment cycle began. It is still prudent to postpone further treatment when symptoms lead to discovery of a large cyst or grossly enlarged ovaries, but clinical studies and experience indicate that routine baseline physical examination or ultrasonography is unnecessary.<sup>91</sup> Nevertheless, regular contact should be maintained to review the progress of treatment and to ensure that any additional evaluation needed is accomplished efficiently.

# Results of Clomiphene Treatment

**Clomiphene will induce ovulation successfully in 70–80% of properly selected women.**<sup>102,103</sup> The likelihood of response decreases with increasing age and body mass index and with the extent of any associated hyperandrogenemia in anovulatory women. Interestingly, women with amenorrhea are more likely to conceive than those with oligomenorrhea,<sup>102</sup> possibly because infertile women who menstruate also likely ovulate, albeit infrequently, and are more likely to have other coexisting infertility factors.

**Among anovulatory infertile women who respond to clomiphene treatment, the overall cycle fecundability is approximately 15%.** In women with no other infertility factors, cycle fecundability may reach as high as 22%, comparable to that observed in normal fertile couples after discontinuation of barrier contraception and those with male factor infertility receiving therapeutic donor inseminations.<sup>102</sup> **Cumulative pregnancy rates of 70–75% can be expected over six to nine cycles of treatment.**<sup>100,104</sup> Thereafter, cycle fecundability falls substantially. **When pregnancy is not achieved within 3–6 clomiphene-induced ovulatory cycles, the infertility investigation should be expanded to exclude other infertility factors not yet evaluated, or the overall treatment strategy should be modified if evaluation is already complete. Prolonged treatment with clomiphene is inappropriate, particularly for women over age 35.**

## Side Effects

Clomiphene treatment generally is very well tolerated. Minor side effects are relatively common but rarely are persistent or severe enough to require that treatment be discontinued.

Transient hot flashes, usually limited to the short interval of treatment, occur in 10–20% of women.<sup>105</sup> Considering that clomiphene causes a central misperception that endogenous estrogen levels are low, vasomotor symptoms are not difficult to understand. Other mild and less common side effects include headache, breast tenderness, pelvic pressure or pain, and nausea (2–5%). Visual disturbances (blurred or double vision, scotomata, light sensitivity) are uncommon (1–2%) and reversible, but reports of persistent “afterimages” (palinopsia) and light sensitivity (photophobia) make them nonetheless unnerving<sup>106</sup>; when such symptoms appear, prudence dictates that treatment be abandoned in favor of alternative methods for ovulation induction.

# Risks

Clomiphene treatment has risks, but serious complications are rare. Inevitably, questions arise concerning the risks for multiple pregnancy, congenital anomalies, and other potential adverse outcomes associated with clomiphene treatment.

The principal risk associated with clomiphene treatment is an increased risk for conceiving a **multiple pregnancy**. The clomiphene-induced increase in FSH secretion is only transient, so normal selection mechanisms still operate to yield only a single mature follicle in most treatment cycles in anovulatory women. **Nevertheless, multifollicular development is relatively common and the overall risk of multiple pregnancy is increased to approximately 7–10%.**<sup>107,108,109</sup> The large majority of multiple pregnancies conceived in clomiphene-induced cycles are twins; the risk for triplets is 0.3–0.5%, for quadruplets 0.3%, and for quintuplets 0.1%.<sup>29,110</sup> **The higher risk of multifetal gestation is another reason to treat with the lowest effective dose of clomiphene; higher doses do not improve results and only increase the risk of superovulation and multiple pregnancy, with all of the attendant antenatal and neonatal complications.**

**There is no evidence that clomiphene treatment increases the overall risk of birth defects or of any one anomaly in particular.**<sup>111</sup> Several large series have examined the question and have drawn the same conclusion.<sup>107,108,109,111,112</sup> In a series of 1,034 pregnancies resulting from clomiphene treatment, 14.2% ended in miscarriage, 0.5% in ectopic pregnancy, 0.1% in molar pregnancy, and 1.6% in stillbirth, and among 935 live born infants, malformations were detected in 21 (2.3%).<sup>111</sup> Earlier suggestions that the risk of neural tube defects might be higher in pregnancies conceived after clomiphene treatment were not confirmed in later investigations.<sup>113,114</sup> A small study of pregnancy outcomes in women exposed inadvertently to clomiphene during the first trimester of pregnancy found no evidence of teratogenicity.<sup>115</sup> There also is no evidence that clomiphene treatment increases the risk of **developmental delay or learning disability** in children conceived during clomiphene treatment.<sup>116</sup>

Early studies suggested that the incidence of spontaneous **miscarriage** in pregnancies resulting from clomiphene treatment might be increased, but a number of others have observed miscarriage rates no different from those in pregnancies conceived without treatment.<sup>85,100,104,117,118</sup>

The incidence of **ovarian hyperstimulation syndrome** (OHSS) in clomiphene-induced cycles is difficult to determine confidently because definitions of the syndrome vary widely among studies. In general, mild symptoms of ovarian hyperstimulation (transient abdominal discomfort, mild nausea, vomiting, diarrhea, and abdominal

distention) are not altogether uncommon but require only expectant management. When induction of ovulation proceeds in the recommended incremental fashion to establish the minimum effective dose, the risk of clinically significant OHSS (massive ovarian enlargement, progressive weight gain, severe abdominal pain, intractable nausea and vomiting, gross ascites, oliguria) is remote.

The incidence of **ovarian cancer** is decreased among parous women and those using hormonal contraception for prolonged intervals, suggesting that “incessant ovulation” (repeated epithelial disruption and repair) predisposes to the development of ovarian cancer and that treatment with ovulation-inducing drugs might increase the risk.<sup>119</sup> The results of case-control studies conducted in the 1990s lent credence to the notion and raised considerable concern,<sup>120,121</sup> although their conclusions were challenged because of important methodologic flaws. One study compared infertile treated women to fertile women rather than to infertile untreated women, even though infertility and nulliparity were known risk factors for ovarian cancer.<sup>120</sup> Another included cancers of all types and tumors of low malignant potential despite their differing pathophysiology.<sup>121</sup> Since then, numerous studies have confirmed that the incidence of ovarian cancer is increased in infertile women but have failed to find any substantive evidence that ovulation-inducing drugs increase the risk,<sup>122,123,124,125,126,127,128,129,130,131,132</sup> and a pooled analysis of results from eight case-control studies found that fertility drug use among nulliparous subfertile women was associated with an increased incidence of borderline serous ovarian tumors (OR = 2.43, CI = 1.01–5.88) but not with any invasive cancers (OR = 1.60, CI = 0.90–2.87).<sup>133</sup> In 2013, a large U.S. study including 9,825 women, with an average follow-up time of 17.6 years for ovarian cancer cases and 26.2 years for noncases, found that while ever use of clomiphene was not associated with ovarian cancer, women who remained nulligravid were found to have an increased risk of breast cancer with ever use of clomiphene (RR = 3.63, 95% CI = 1.36–9.72).<sup>134</sup>

The results of studies of the risk for **breast cancer** have been conflicting, with some showing no association with ovulation-inducing drugs and others suggesting possible increases in risk in certain subgroups.<sup>128</sup> A 2014 study including 9,892 women who were evaluated for infertility with a median follow-up time of 30 years reported unchanged risk of breast cancer with ever use of clomiphene (HR = 1.05; 95% CI = 0.90–1.22). However, receiving multiple cycles of clomiphene was associated with an increased risk of invasive cancers (HR = 1.69; 95% CI = 1.17–2.46).<sup>135</sup>

A 2017 meta-analysis reported a positive association between clomiphene exposure and **endometrial cancer** among subfertile women (RR = 1.32; 95% CI = 1.01–1.71; very low-quality evidence), although only at high dosage (RR = 1.69, 95% CI = 1.07–2.68) and at a high number of cycles (RR = 1.69, 95% CI = 1.16–2.47). However,



whether the association is due to the underlying conditions requiring clomiphene or the drug itself is uncertain.<sup>136</sup>

Overall, the available data are quite reassuring. **No causal relationship between ovulation-inducing drugs and ovarian, breast, or endometrial cancer has been established, but prolonged treatment with clomiphene nonetheless should be avoided, primarily because it has little hope of success.**

# Adjuvant and Combination Treatments

Clomiphene resistance describes women who do not ovulate in response to clomiphene treatment, not those who fail to conceive despite successful clomiphene-induced ovulation. In the latter group, additional evaluation is indicated to identify other potential coexisting infertility factors not already excluded. If or when that has been accomplished, persistent infertility is best regarded and treated as unexplained infertility ([Chapter 25](#)).

Although most properly selected women will ovulate in response to clomiphene treatment, many do not. Direct ovarian stimulation with exogenous gonadotropins, discussed later in detail, is an obvious alternative, but it is by no means the only option that merits consideration. Many clomiphene-resistant anovulatory infertile women will respond to supplemental or combination treatment regimens. Options include adjuvant treatment with glucocorticoids, exogenous human chorionic gonadotropin (hCG), or metformin and preliminary suppressive therapy (hormonal contraceptives). **It is helpful to be familiar with these less common ovulation induction strategies because many couples are understandably reluctant or unable to pursue the obvious alternative of gonadotropin treatment once fully advised of the associated costs, logistical demands, and risks.**

Failure to respond to one or more of these less commonly employed treatment regimens is not a prerequisite for exogenous gonadotropin therapy. They are simply useful alternatives for those unwilling or unable to pursue gonadotropin therapy and, for some, may be the only option when clomiphene treatment has failed. A choice among them is not entirely arbitrary but should consider specific elements of the patient's history, the results of laboratory evaluation, and observations in previous unsuccessful clomiphene treatment cycles.

## Clomiphene and Glucocorticoids

Numerous studies have examined the efficacy of adjuvant treatment with glucocorticoids in clomiphene-resistant anovulatory women, and all have found that combined treatment with clomiphene and a glucocorticoid can successfully induce ovulation in many who fail to respond to clomiphene alone.<sup>89,137,138,139,140,141</sup> Both continuous and more limited follicular phase treatment regimens (cycle days 5–14) have been described, using either prednisone (5 mg daily) or dexamethasone (0.5–2.0 mg daily). Whereas some studies have suggested that combined treatment with clomiphene and glucocorticoids is most effective in women having elevated serum dehydroepiandrosterone sulfate (DHEA-S) concentrations,<sup>137,138</sup> others have found that treatment also can be effective in those with normal DHEA-S levels<sup>139,141</sup> and in unselected populations of clomiphene-resistant

women.<sup>89,140,142</sup>

In the largest randomized trial involving more than 200 clomiphene-resistant anovulatory infertile women, over 80% of those receiving combined treatment with clomiphene (200 mg daily, cycle days 5–9) and dexamethasone (2 mg daily, cycle days 5–14) ovulated, compared to 20% of controls treated with clomiphene and placebo; the cumulative pregnancy rate in women receiving dexamethasone (40%) was 10-fold higher than in those who received placebo (4%).<sup>141</sup> The mechanism of glucocorticoid action remains unclear but appears to involve more than simple androgen suppression. Other possibilities include direct effects on the developing oocyte and indirect effects on intrafollicular growth factors and cytokines, which may act synergistically with FSH.<sup>143</sup> Regardless, adjuvant treatment with glucocorticoids may be justified for three to six cycles when it is successful but should be promptly discontinued when it is not. There is no evidence that glucocorticoid treatment has any important side effects or risks when used in the doses and durations described.

## Clomiphene and HCG

Although there are few if any data to demonstrate its value, exogenous hCG has been used commonly as a surrogate LH surge to trigger ovulation in clomiphene-induced cycles, particularly when IUI is performed, as in couples with unexplained infertility and those with a coexisting male factor. Adjuvant hCG treatment can be useful but has limited indications, distinct disadvantages, and potential consequences.

In anovulatory women who fail to ovulate in response to clomiphene alone, adjuvant hCG treatment is based on the premise that clomiphene may be successful in stimulating the emergence of a preovulatory follicle but ultimately fail to trigger an endogenous LH surge and to induce ovulation. Physiologically, and in practice, the scenario is unlikely. Moreover, serial transvaginal ultrasonography is required to demonstrate the phenomenon and to ensure that the ovulatory stimulus is delivered at the appropriate time. If administered blindly and prematurely, before the dominant follicle is mature enough to respond, hCG is more likely to induce atresia than ovulation.

The question of when to administer hCG presents a dilemma. Although hCG commonly is administered when the lead follicle reaches 18–20 mm,<sup>144</sup> clinical studies indicate that the peak preovulatory follicular diameter in successful clomiphene-induced ovulatory cycles ranges between 18 and 30 mm (mean 25 mm).<sup>91,145,146</sup> Considering that the preovulatory follicle grows approximately 2 mm/day as it approaches maturity,<sup>95,96</sup> the corresponding interval may thus span up to 6 days. Normally, the preovulatory follicle triggers its own ovulatory stimulus at the peak of maturity by generating and maintaining the estrogen levels that are required to induce the LH surge. The timing of

the spontaneous LH surge is therefore always optimal, but that of hCG treatment can never be more than an educated guess.

**When combined treatment with clomiphene and IUI is required, insemination usually is best performed on the day after detection of the spontaneous LH surge, using one of the now widely available commercial kits designed for the purpose, because ovulation generally occurs 14–26 hours after urinary LH surge detection.**<sup>90,147</sup> However, the lower limit of LH detection usually is between 20 and 40 IU/L, and many ovulatory women exhibit peak LH levels below 40 IU/L or surges of brief duration that may escape detection<sup>92</sup>; false-negative results are therefore not uncommon and frustrating. **Exogenous hCG can be useful for the few women who require IUI but repeatedly fail to detect the LH surge despite other objective evidence of successful ovulation induction.** In such circumstances, we believe that hCG is best postponed until the preovulatory follicle reaches or exceeds 20 mm in mean diameter. Ovulation occurs 34–46 hours after hCG injection,<sup>148</sup> so IUI usually is performed approximately 36 hours later.

**When the LH surge can be detected, adjuvant hCG treatment has no value and only adds unnecessary expense and inconvenience.** A 2014 meta-analysis including two randomized controlled trials where anovulatory women undergoing ovulation induction with clomiphene citrate were given an ovulatory dose of hCG or not reported similar live birth, ovulation, pregnancy, and miscarriage rates.<sup>149</sup> Another meta-analysis including seven studies comparing hCG trigger with LH monitorization for timing IUI for women who were treated with clomiphene reported significantly lower pregnancy rates in the hCG group.<sup>150</sup> The idea that hCG may still serve to ensure or improve the quality of luteal function even if it is not required to trigger ovulation also is not supported by existing data. In spontaneous ovulatory cycles, hCG treatment superimposed on the endogenous LH surge has no effect on luteal phase duration or serum estrogen or progesterone concentrations<sup>151</sup>; the same is true in clomiphene-induced ovulatory cycles.<sup>152</sup> In sum, adjuvant hCG treatment is best limited to those few women who require IUI and ovulate but cannot reliably detect a midcycle LH surge.

## Clomiphene and Metformin

Insulin resistance and hyperinsulinemia are common features of PCOS and an important contributing cause of the hyperandrogenism and chronic anovulation that characterize the disorder. Anovulatory infertile women with PCOS and hyperinsulinemia also are typically more resistant to clomiphene treatment.

Recognition of the pathophysiologic importance of insulin resistance in PCOS stimulated intense interest in the use of insulin-sensitizing agents for the treatment of the

disorder. Metformin is a biguanide oral insulin-sensitizing agent that acts primarily by reducing hepatic gluconeogenesis but also decreases intestinal absorption of glucose and increases peripheral glucose uptake and utilization. The effects of metformin on insulin levels and sensitivity, androgen concentrations, and other metabolic and clinical measures are considered at length elsewhere in this text ([Chapter 11](#)); its adjunctive use as an ovulation-inducing agent is the focus here.

Treatment with metformin alone or with other insulin-sensitizing drugs (thiazolidinediones, D-chiro-inositol) can increase ovulation rates in some women with PCOS,<sup>153,154,155,156,157</sup> but there is no practical method for predicting those who will respond. The literature is mostly populated with small studies that include heterogeneous groups of patients, which vary in their BMI, insulin resistance (which has not been tested at all or tested using different methodologies), and prior treatment status (i.e., clomiphene resistant or treatment naïve). Moreover, different treatment regimens with regard to timing and dose have been employed across these studies. Finally, live birth rate, the most important outcome of treatment, has not been reported in many. As can be expected, results from such studies are often heterogeneous preventing reliable pooling of their data. As such, assessment of the role of metformin and other insulin sensitizers as adjuvants for ovulation induction is difficult, despite years of research.<sup>157</sup>

In the largest randomized trial, 626 women with PCOS from the United States with oligomenorrhea and hyperandrogenism and a mean BMI greater than 34 kg/m<sup>2</sup> were treated with clomiphene, metformin, or both.<sup>118</sup> Ovulation and live birth rates were significantly higher with clomiphene alone compared with metformin (49% vs. 29% and 22.5% vs. 7.2%, respectively;  $P < 0.001$ ). Addition of metformin did not significantly improve outcomes compared to clomiphene alone.

A 2017 meta-analysis evaluated the effectiveness and safety of insulin-sensitizing drugs in improving reproductive outcomes for women with PCOS undergoing ovulation induction and concluded that metformin is associated with significantly higher rates of ovulation, clinical pregnancy, and live birth rates compared to placebo or no treatment.<sup>156</sup> However, the analysis for live birth rate included four trials with a total of 435 women and demonstrated only a marginal benefit with an odds ratio of 1.59 (CI = 1.0–2.51). When clomiphene was compared to metformin, live birth rates were similar between the groups (OR = 0.71, CI = 0.49–1.01), but data were very low quality and were found to be inconclusive and inconsistent. In subgroup analysis by obesity status, data from the nonobese group showed a possible benefit from metformin for live birth (OR = 1.71, 95% CI = 1.00–2.94) and pregnancy (OR = 1.56, 95% CI = 1.05–2.33) rate and no clear difference in ovulation rates (OR = 0.81, 95% CI = 0.51–1.28). Surprisingly, obese women treated with metformin had a lower ovulation (OR = 0.29, 95% CI = 0.20–0.43), clinical pregnancy (OR = 0.34, 95% CI = 0.21–0.55), and live

birth (OR = 0.30, 95% CI = 0.17–0.52) rate, compared to clomiphene. The same meta-analysis also concluded that combined treatment with metformin and clomiphene achieves higher ovulation (OR = 1.57, CI = 1.28–1.92) and pregnancy rates (OR = 1.59, CI = 1.27–1.99), compared to treatment with clomiphene alone.<sup>156</sup> There was no conclusive evidence that combined treatment with metformin and clomiphene can increase live birth rates over those achieved with clomiphene alone (OR = 1.21, CI = 0.92–1.59). The results for combined therapy did not vary across subgroups based on obesity status. The attempt in combining the two medications can be justified for women having few alternatives besides ovarian drilling or treatment with exogenous gonadotropins. Indeed, a sensitivity analysis based on six studies including clomiphene-resistant women showed a more pronounced increase in ovulation rate (OR = 4.89, CI = 2.62–9.13). However, clomiphene resistance was defined differently in all primary trials.

Limited evidence indicates that combined treatment with metformin and rosiglitazone,<sup>158</sup> or with clomiphene and rosiglitazone,<sup>159</sup> is no more effective than metformin alone. Combined with the safety alert issued by the U.S. Food and Drug Administration concerning a possible increased risk of ischemic cardiovascular events in patients receiving treatment with thiazolidinediones,<sup>160</sup> these data argue against their adjuvant use for ovulation induction. **In summary, combined treatment with metformin and clomiphene deserves consideration in women who prove to be clomiphene resistant.**

A 2010 randomized trial compared combined treatment with metformin and clomiphene with aromatase inhibitors in 250 clomiphene-resistant women.<sup>161</sup> Combination treatment involved 500 mg metformin 3 times daily for 6–8 weeks followed by 150 mg/day clomiphene for 5 days. Despite significantly higher ovulation rates with clomiphene-metformin than with letrozole (69.6% vs. 64.9%), clinical pregnancy rates were similar between groups (14.4% vs. 14.7%).

Metformin treatment is commonly associated with gastrointestinal side effects including nausea, vomiting, abdominal cramps, and diarrhea that can be severe enough to limit the dose administered or require discontinuation of treatment.<sup>162,163,164,165</sup> Because side effects tend to be dose-dependent and diminish with time, it is usually best to begin with a low daily dose (500 mg), increasing gradually at weekly intervals to a daily dose of 1,500–2,000 mg, as tolerance allows. Lactic acidosis can be a rare complication of metformin treatment, although recent systematic reviews have questioned whether there is a true causal relationship.<sup>166,167</sup> Women at highest risk are those with chronic hypoxemic conditions related to cardiovascular, renal, hepatic, and pulmonary disease and advanced age.

Although some have advocated metformin treatment to reduce the increased risk for

miscarriage in women with PCOS,<sup>168,169,170</sup> available data suggest otherwise. Miscarriage rates were similar between women treated with metformin compared to no treatment and between women treated with metformin compared to clomiphene; women who received combination therapy with metformin and clomiphene had significantly higher rates of miscarriage than women who received clomiphene alone (OR = 1.59, CI = 1.03–2.46). Metformin treatment during pregnancy also has been advocated to reduce the risk for developing gestational diabetes and other pregnancy complications in women with PCOS.<sup>171,172</sup> In diabetic women, treatment with metformin during pregnancy has been associated with an increased prevalence of preeclampsia and increased perinatal mortality in some studies,<sup>173</sup> but not in others.<sup>174,175</sup> Therefore, although there is no evidence that metformin treatment during pregnancy is associated with any increased risk for major fetal malformations,<sup>176</sup> and metformin is currently classified as U.S. Food and Drug Administration pregnancy category B, routine metformin treatment during pregnancy is not recommended for women with PCOS.

## **Preliminary Suppressive Therapy**

Considering that anovulation reflects a dysfunctional hypothalamic-pituitary-ovarian axis, it is reasonable to think that an interval of preliminary suppressive therapy might help to restore harmony and ovulatory function, at least temporarily. The idea is consistent with clinical observations of a few normal menstrual cycles immediately following discontinuation of estrogen-progestin contraception in some women who previously exhibited abnormal menstrual patterns. Limited data suggest that a 2-month interval of continuous estrogen-progestin contraception can effectively suppress serum LH and androgen levels and that ovulation rates up to 70% and cumulative pregnancy rates over 50% can be achieved with clomiphene treatment immediately thereafter in women who were previously clomiphene resistant.<sup>177,178</sup>

A long-acting GnRH agonist, alone or in combination with an estrogen-progestin contraceptive, can be used for the same purpose. Combined suppressive therapy with a GnRH agonist and an estrogen-progestin contraceptive (3–6 months) achieves a greater and longer-lasting reduction in serum LH and androgen concentrations than treatment with estrogen-progestin contraception alone and also prevents the otherwise inevitable estrogen deficiency symptoms associated with the use of a GnRH agonist. Spontaneous resumption of ovulatory cycles can follow,<sup>179,180,181</sup> potentially eliminating even the need for clomiphene treatment. GnRH antagonists would likely have a similar effect and allow the use of oral medication.

# AROMATASE INHIBITORS

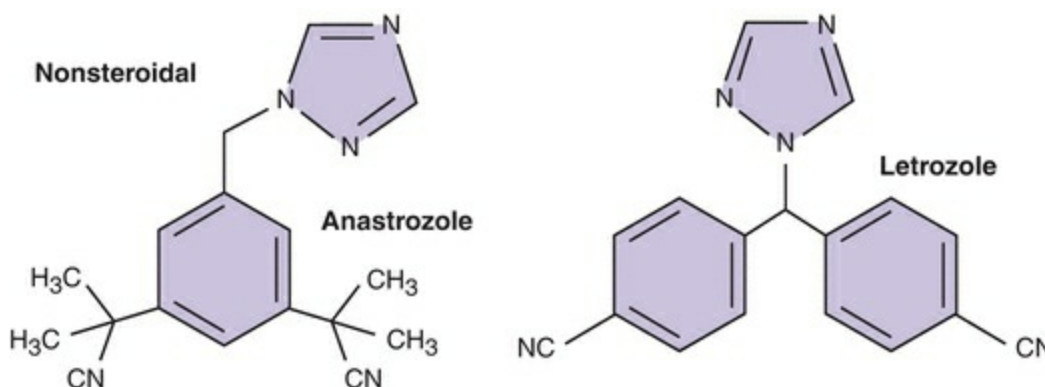
---

Aromatase inhibitors, which were used primarily in the treatment of postmenopausal breast cancer, emerged as a new class of ovulation-inducing agents. Even though the use of aromatase inhibitors for ovulation induction has been controversial since their first introduction in 2001,<sup>182</sup> letrozole is now considered the first-line therapy for ovulation induction in women with PCOS,<sup>183</sup> as it provides significantly higher live birth rates compared to clomiphene.<sup>184</sup>



# Pharmacology and Mechanism of Action

Anastrozole and letrozole are triazole (antifungal) derivatives that act as potent, competitive, nonsteroidal inhibitors of aromatase,<sup>185,186</sup> the enzyme that catalyzes the rate-limiting step in estrogen production. They block estrogen production both in the periphery and in the brain, resulting in a compensatory increase in pituitary gonadotropin secretion that stimulates ovarian follicular development.<sup>187,188,189</sup> In this regard, their mechanism of action is similar to, but also distinct from, that of clomiphene. Although both stimulate increased gonadotropin secretion by decreasing the negative feedback effects of estrogen during treatment, clomiphene does so via depletion of central estrogen receptors, whereas aromatase inhibitors decrease estrogen production directly (**Figure 27.3**).



**FIGURE 27.3**

At least in theory, the different actions of aromatase inhibitors and clomiphene may have functional, and clinical, importance. Lower estradiol levels and higher luteal phase progesterone levels attained in letrozole-stimulated cycles than clomiphene-stimulated cycles may be the mechanism behind higher live birth rates with letrozole.<sup>22</sup> Gonadotropin secretion is anticipated to promptly decrease due to negative feedback by rapidly rising estrogen production by growing follicles following the cessation of aromatase inhibitor. To the contrary, the lack of immediate negative feedback following cessation of clomiphene, due to the depletion of central estrogen receptors, results in a more sustained increase in gonadotropin levels that is more likely to support multifollicular development. However, number of growing follicles and mono-ovulatory cycles are similar between women stimulated with clomiphene and letrozole.<sup>190</sup> Likewise, multiple pregnancy rates are also at least as low in letrozole as in clomiphene-induced cycles.<sup>184</sup> The transient accumulation of androgen substrate during treatment with aromatase inhibitors also may increase FSH receptor expression<sup>191,192</sup>

and production of insulin-like growth factor-1 (IGF-1),<sup>193,194,195</sup> amplifying the actions of FSH.

# Peripheral Actions

Despite lower serum estradiol levels in letrozole-stimulated cycles than in clomiphene-stimulated cycles, letrozole could have been expected to have less of an adverse effect on endometrial growth, since it does not block estrogen receptors. Indeed, a 2018 systematic review comparing the effect of clomiphene citrate and other ovulation induction drugs on endometrial thickness in women with WHO group 2 anovulation reported significantly higher endometrial thickness in letrozole-induced cycles (15 RCTs, 1,957 women, 3,892 cycles; weighed mean difference, 1.39 mm; 95% CI = 2.27–0.51).<sup>196</sup> However, the results in individual studies demonstrated high heterogeneity and comprise low-quality evidence. Whether the effect of letrozole on endometrial thickness has a significant effect on treatment outcome in terms of pregnancy and live birth rates is controversial. Few studies investigated molecular markers or endometrial growth and receptivity in letrozole-stimulated cycles. In general, letrozole was found to be associated with a more favorable molecular profile than clomiphene.<sup>197</sup> Clomiphene is associated with significantly decreased protein expression of active B-catenin, inactive glycogen synthase kinase-3 beta, and estrogen receptor 1.<sup>198</sup> A retrospective study involving women undergoing IVF reported increased integrin  $\alpha\beta3$  expression following stimulation with letrozole.<sup>199</sup> However, whether integrin expression is different between letrozole- and clomiphene-stimulated cycles is controversial.<sup>200</sup>

Limited data suggest that letrozole does not have a clinically relevant direct effect on oocytes or embryos. In a mouse model of PCOS, superovulation with letrozole was not found to affect meiotic spindle assembly or blastocyst development, compared with FSH-stimulated superovulation.<sup>201</sup>

# Clinical Indications

Following publication of large randomized controlled trials demonstrating higher live birth rates with letrozole than with clomiphene, it is now regarded the drug of choice for ovulation induction in anovulatory infertile women with PCOS.<sup>183</sup> The drug has also been tested in ovulatory women with unexplained infertility (in combination with IUI).<sup>202</sup>

Similar to clomiphene, letrozole is ineffective in women with hypogonadotropic hypogonadism (WHO Group 1), who already have low serum estrogen concentrations and a dysfunctional hypothalamic-pituitary-ovarian axis.

Despite evidence of effectiveness and safety in well-designed large randomized controlled trials, letrozole is still used off-label for ovulation induction in the United States, since it has not been approved by the U.S. Food and Drug Administration (FDA) for this indication.

# Aromatase Inhibitor Treatment Regimens

In almost all studies conducted to date, letrozole (2.5–7.5 mg daily) and anastrozole (1 mg daily) have been administered for a 5-day interval. Early on, a phase II randomized controlled trial comparing a single-dose therapy with anastrozole and 5-day course of clomiphene reported significantly lower ovulation rates with anastrozole and the sponsoring company stopped the development of the drug.<sup>203</sup> Thus, letrozole is the most studied and the most commonly used aromatase inhibitor in ovulation induction.

Letrozole is administered orally, typically beginning on the third to fifth day after the onset of a spontaneous or progestin-induced menses. Ovulation and conception rates and pregnancy outcomes are similar when treatment starts anywhere between cycle days 3 and 5.<sup>204</sup> In women with amenorrhea, treatment can begin immediately, without inducing endometrial shedding; however, pregnancy must be excluded. The starting dose for letrozole is 2.5 mg a day for 5 days. If 2.5 mg/day fails to induce ovulation, the dosage can be increased by 2.5 mg increments up to a maximum of 7.5 mg/day for 5 days. Despite the absence of published evidence with letrozole, dose increments can be done in the same cycle without inducing bleeding, like the stair-step protocol with clomiphene.<sup>99</sup> One trial comparing outcomes achieved with 5 or 10 days of letrozole treatment (5 mg and 2.5 mg daily, beginning on cycle day 1, respectively) in clomiphene-resistant women (100 mg daily) observed significantly more preovulatory follicles (3.0 vs. 1.8) and higher pregnancy rates (17.4% vs. 12.4%) in women receiving the longer course of treatment.<sup>205</sup>

The same methods used for diagnosis of a spontaneous or clomiphene-induced ovulation can be used to determine the response to letrozole. Whether monitoring and triggering of ovulation is necessary and improves results over that achieved without monitoring and fertility-oriented intercourse is controversial. However, it may be prudent to monitor during the follicular phase of the first cycle to confirm ovulation or to allow timely dose increments to achieve ovulation.

# Results of Treatment with Aromatase Inhibitors

Several trials have compared letrozole and clomiphene in anovulatory women without documented clomiphene resistance. The largest involved 750 patients who were randomized to receive letrozole (2.5 mg daily increased up to a maximum of 7.5 mg/day in case of anovulation) or clomiphene (50 mg daily increased up to a maximum of 150 mg/day), without ovulation trigger, up to five treatment cycles. In the letrozole group, a significantly higher proportion of women achieved ovulation (88.5% vs. 76.6%, RR = 1.16; 1.08–1.24), and the proportion of ovulations over total treatment cycles was significantly higher (61.7% vs. 48.3%, RR = 1.28; 1.19–1.37). Cumulative pregnancy (27.3% vs. 21.5%) and live birth (27.5% vs. 19.1%, RR = 1.44; 1.10–1.87) rates were also significantly higher with letrozole treatment.<sup>22</sup> One randomized trial, which recruited 100 anovulatory women with PCOS who had never received ovulation induction, also reported significantly higher ovulation (60% vs. 32%) and a nonsignificant increase in pregnancy rate (26% vs. 14%) with letrozole (5 mg/day) than clomiphene (100 mg/day).<sup>206</sup> A 2018 systematic review reported significantly higher live birth rates with letrozole than clomiphene (OR = 1.79; 1.42–2.25).<sup>184</sup> The beneficial effect of letrozole seems independent of body mass index, that is, despite decreasing overall live birth rates with increasing BMI, letrozole outperforms clomiphene across categories of BMI.<sup>22,184</sup> Miscarriage per pregnancy (OR = 0.96; 0.65–1.42) and multiple pregnancy rates (OR = 0.61; 0.41–1.16) are also similar between letrozole- and clomiphene-induced cycles.<sup>184</sup> **Available evidence suggests that letrozole should be considered the first-line agent for ovulation induction in anovulatory women with PCOS.**

In an early proof of concept trial involving anovulatory clomiphene-resistant women, 9/12 of patients (75%) ovulated after treatment with letrozole (2.5 mg daily) and hCG (lead follicle > 20 mm), three conceived (resulting in two singleton births), and normal endometrial proliferation was observed in all.<sup>182</sup> **Aromatase inhibitors can also be effective in anovulatory women who fail to ovulate in response to clomiphene treatment.**

Aromatase inhibitors also might be considered for women who respond to clomiphene but exhibit grossly poor endometrial proliferation. Indeed, letrozole is associated with a significantly thicker endometrium; however, the mean difference is small at 1.39 mm (95% CI = 2.27–0.51).<sup>196</sup> **All studies have included monitoring with ultrasonography and the vast majority used adjuvant treatment with hCG, so it is unclear whether these additions to the treatment regimen are necessary to achieve success. If not, the substantially lower complexity, risks, and costs of treatment, compared to the alternative of gonadotropin therapy, make it easy to justify a trial**

**of treatment with an aromatase inhibitor for clomiphene-resistant anovulatory women.**

## Side Effects

Letrozole is generally well tolerated, and the most common side effects of letrozole are headaches and cramps. Women on letrozole report more fatigue (20%) and dizziness (12%) than women on clomiphene.<sup>22</sup> However, hot flushes are less common with letrozole (20.3% vs. 33.0%).<sup>22</sup>



## Risks

The major risk of ovulation induction is the occurrence of a multiple pregnancy. Even though a rapid decline in serum FSH level is anticipated following the cessation of letrozole, the incidence of monofollicular development and the risk of multiple pregnancy are similar with clomiphene.<sup>184</sup> The risk of multiple pregnancy is about 3–7%. While the vast majority of multiples are limited to twins, a case of sextuplets has been reported following ovulation induction with letrozole at a dose of 7.5 mg/day.<sup>207</sup> It would be prudent to monitor ovarian response and cancel cycles when the patient is regarded to be at risk of multifollicular development, for example, with prior multifollicular development or requiring high dose of letrozole.

Despite initial concerns regarding increased risk of fetal anomalies following ovulation induction with aromatase inhibitors, there is no evidence suggesting letrozole is any more teratogenic than clomiphene. One case series comparing the incidence of congenital malformations in 911 newborns of women who conceived after treatment with letrozole (14/514, 2.4%) or clomiphene (19/397, 3.0%) found no difference.<sup>208</sup> Another comparing the incidence of birth defects in children born to mothers treated with letrozole or clomiphene to that in pregnancies conceived without treatment also observed no difference.<sup>209</sup>

The risk of clinically significant OHSS (massive ovarian enlargement, progressive weight gain, severe abdominal pain, intractable nausea and vomiting, gross ascites, oliguria) is very low when letrozole is used cautiously in an incremental manner.

**In sum, the available data suggest that letrozole is more effective than clomiphene as a first-line treatment for ovulation induction in anovulatory women with PCOS, without a significant increase in complications or side effects.**

# LAPAROSCOPIC OVARIAN DRILLING

---

Surgical treatments aimed at restoring ovulatory function in anovulatory infertile women date back to the classic bilateral ovarian wedge resection described originally by Stein and Leventhal in 1935.<sup>210</sup> The procedure understandably fell out of favor after the introduction of clomiphene citrate and gonadotropins for ovulation induction. Advances in laparoscopic surgery sparked renewed interest in the procedure, with ovarian “drilling” now representing the modern equivalent of the classical wedge resection and another treatment option for anovulatory women who are resistant to oral ovulation induction agents.

Several methods for ovarian drilling have been described, including electrocautery or laser vaporization (three to six sites per ovary, avoiding surfaces near the tubo-ovarian interface to minimize the risk for adhesions that might adversely affect ovum capture).<sup>211,212,213</sup> All are intended to cause focal destruction of the ovarian stroma in efforts to decrease both intraovarian and systemic androgen concentrations. There is no evidence for the superiority of any one method, but the most common technique involves electrocautery using a unipolar needle electrode insulated above the distal 1–2 cm. Unilateral ovarian drilling seems comparable with bilateral drilling for the majority of women, perhaps except for clomiphene-resistant patients.<sup>214,215,216</sup>

Postoperative serum concentrations of androstenedione and testosterone decrease, at least for a time,<sup>217,218,219,220</sup> and inhibin concentrations also decline.<sup>221,222</sup> Both changes likely contribute to an associated increase in FSH levels. As with the classical surgical procedure, the principal risk associated with laparoscopic ovarian drilling is postoperative adnexal adhesion formation that may decrease overall fertility, although the risk and severity of adhesions are lower<sup>223,224,225,226</sup>; second-look laparoscopy and adhesiolysis do not appear necessary or useful.<sup>227,228</sup> There is one report of unilateral ovarian atrophy after ovarian drilling with electrocautery<sup>229</sup>; however, the energy levels applied in that case were almost 40 times higher than the currently recommended dose. Whether ovarian drilling might adversely affect ovarian reserve and predispose to early menopause is controversial. Despite a significant decline in serum AMH levels and ovarian volume after drilling, 6 months after the procedure, postoperative levels were still higher than age- and BMI-matched ovulatory fertile women in a retrospective study<sup>230</sup>; other data indicate that reductive ovarian surgery, including ovarian wedge resection, increases risk for early menopause.<sup>231</sup>

In numerous uncontrolled observational studies, 40–90% of women have ovulated after laparoscopic ovarian drilling and approximately half of those have conceived.<sup>211,212,213,224,232</sup> In truly clomiphene-resistant women, ovarian drilling can

improve clomiphene sensitivity or response to exogenous gonadotropins when it does not restore spontaneous ovulatory cycles.<sup>233</sup> When considering laparoscopic ovarian drilling as a treatment option in clomiphene-resistant anovulatory infertile women, the most relevant data derive from randomized controlled trials comparing surgical treatment with ovulation induction using exogenous gonadotropins.<sup>227,234,235</sup> A 2012 systematic review and meta-analysis including 25 trials found no evidence of a difference in live birth (OR = 0.97, CI = 0.59–1.59) or pregnancy rate (OR = 1.01, CI = 0.72–1.32).<sup>216</sup> After 12 months, the ovulation rate achieved with drilling (52%) was similar to that with gonadotropin therapy (62%). However, as might be expected, laparoscopic ovarian drilling yields far fewer multiple pregnancies than gonadotropin treatment (1% vs. 16%; OR = 0.13, CI = 0.03–0.52); the miscarriage rates associated with surgical and medical treatment are comparable.<sup>216</sup>

The ideal candidates for ovarian drilling are women who are not obese and have no other infertility factors. The procedure often is unsuccessful in obese women (BMI > 30 kg/m<sup>2</sup>),<sup>236,237</sup> and whereas over 80% of women can be expected to conceive after surgery when clomiphene-resistant anovulation is the sole cause of infertility,<sup>236,238</sup> only 15–30% achieve pregnancy when there is a coexisting tubal, male, or other infertility factors.<sup>219,238</sup>

**Laparoscopic ovarian drilling can be an effective therapeutic option for anovulatory infertile women who are resistant to oral ovulation induction agents, but the temporary effects of treatment, the risk of postoperative adhesions, and the theoretical risk of adverse effects on ovarian reserve deserve careful consideration and discussion. The procedure is perhaps best reserved for women who are unable or unwilling to accept the costs and risks associated with gonadotropin therapy.**

# EXOGENOUS GONADOTROPINS

---

Exogenous gonadotropins have been used to induce ovulation in gonadotropin-deficient women and those who fail to respond to other, less complicated forms of treatment for nearly 50 years. They are highly effective but also very costly and associated with substantial risks including multiple pregnancy and OHSS. **Consequently, exogenous gonadotropins should be used only by clinicians having the training and experience necessary to provide safe and effective treatment.**

# Gonadotropin Preparations

Gonadotropin preparations have evolved gradually over the years, from relatively crude urinary extracts to more highly purified urinary extracts to the recombinant preparations in common use today.<sup>239,240</sup>

For almost 30 years, the only exogenous gonadotropins available were human menopausal gonadotropins (hMG, menotropins), an extract prepared from the urine of postmenopausal women containing equivalent amounts (75 IU) of FSH and LH per ampule or vial and requiring intramuscular injection. Originally, the urinary source was a single convent in Italy, but later, collections were expanded to a number of centers in other countries.<sup>241</sup> Urinary menotropins also contain small but measurable and varying amounts of hCG, most of it added intentionally during the manufacturing process to provide the appropriate amount of LH activity.<sup>242</sup> Clinical use of hMG began in 1950 but the clinical trials did not begin until after 1960.<sup>243,244</sup> Relatively crude gonadotropin extracts like traditional hMG also contained significant amounts of uncharacterized urinary protein that may be antigenic.<sup>245</sup> Contemporary hMG preparations are more highly purified than in the past and can be administered subcutaneously.<sup>246</sup>

Beginning about 25 years ago, more purified urinary FSH preparations (urofollitropin) were developed by removing LH from urinary extracts using immunoaffinity columns containing polyclonal anti-hCG antibodies.<sup>247</sup> Early preparations of purified urinary FSH (75 IU) contained less than 1 IU LH but a considerable amount of other urinary protein and still required intramuscular administration. Further purification using monoclonal antibodies specific for FSH yielded a preparation containing less than 0.1 IU LH and less than 5% unidentified protein. The even more highly purified products now in use contain less than 0.001 IU LH, very low levels of urinary protein, and can be administered subcutaneously.

Just over 20 years ago, the in vitro production of recombinant human FSH was achieved through genetic engineering. Briefly summarized, the process involves introduction of the genes encoding the  $\alpha$ - and  $\beta$ -FSH subunits into the genome of a Chinese hamster ovary cell line, which then synthesizes and secretes a glycosylated bioactive dimeric FSH that is purified by immunochromatography using a specific anti-FSH monoclonal antibody. Recombinant FSH preparations contain less acidic FSH isoforms that have a shorter half-life than those derived from human urine but stimulate estrogen secretion as or even more efficiently.<sup>248</sup> The advantages of recombinant FSH preparations include the absence of urinary protein, more consistent supply, and less batch-to-batch variation in biologic activity. The two recombinant FSH preparations currently available are marketed as follitropin alfa and follitropin beta. They are both structurally identical to native FSH and contain 1 alpha and 1 beta glycoprotein chain,

but the posttranslational glycosylation process and purification procedures for the two are different.<sup>249</sup> Despite the subtle differences in structure, they are functionally the same. The biologic activity of all FSH preparations, including recombinant formulations, is ultimately confirmed using the classic Steelman-Pohley ovarian bioassay.<sup>250</sup>

Recombinant technology has also been used to create a new chimeric gene containing the coding sequences of the FSH  $\beta$ -subunit and the C-terminal peptide of the hCG  $\beta$ -subunit (containing additional glycosylation sites). Coexpression of the  $\alpha$ -subunit and the chimeric FSH  $\beta$ -subunit produces a new molecule called corifollitropin alfa, which has a prolonged half-life and enhanced in vivo bioactivity compared with wild-type FSH. Early studies in women suppressed by treatment with a long-acting GnRH agonist have confirmed the extended half-life of the compound, and clinical trials have demonstrated that corifollitropin alfa can induce and sustain multifollicular growth for a week in women receiving ovarian stimulation for IVF. Corifollitropin alfa provides the means for simpler and more convenient treatment compared with conventional treatment regimens involving daily injections with FSH and GnRH agonist. However, this recombinant gonadotropin with extended half-life is designed to induce multifollicular development, and it is not well suited for ovulation induction where unifollicular development is the objective.<sup>251,252</sup> This product is widely available outside of the United States.

Most recently, follitropin delta, the first recombinant FSH protein that is expressed in a human cell line (PER.C6), has been available for use in assisted reproductive technologies (ART). Follitropin delta has the same amino acid FSH sequence as follitropin alfa, but the glycosylation patterns of the two molecules are different. Follitropin delta has distinct pharmacokinetics and pharmacodynamics, with higher exposure and lower serum clearance than follitropin alfa.<sup>253</sup> Similar to corifollitropin alfa, follitropin delta is also licensed for use in ART cycles aiming at multifollicular development and is currently not suitable for induction of monofollicular development.

A recombinant form of human LH having physicochemical, immunologic, and biologic activities comparable to those of human pituitary LH also is available, supplied in vials with syringes designed to deliver 75 IU.<sup>254,255,256</sup> Combined use of recombinant LH and FSH (or hMG) helps to promote follicular development in women with hypogonadotropic hypogonadism who have a profound LH deficiency<sup>257</sup> but otherwise does not appear necessary.<sup>258,259</sup>

Traditionally, and still today, by virtue of its structural and biologic similarity to LH, hCG is used to simulate the LH surge and induce ovulation in gonadotropin-stimulated cycles once follicle development reaches maturity. LH/hCG promotes the final stages of follicular and oocyte maturation (from prophase I, the germinal vesicle

stage, through meiotic maturation and metaphase II), which requires approximately 36 hours to complete, and ovulation generally occurs approximately 4 hours later. A recombinant form of hCG, produced using techniques similar to those described earlier for recombinant FSH,<sup>260</sup> has widely replaced hCG extracted from human pregnancy urine and placental tissue. Studies indicate that 250 mcg of the recombinant product yields results comparable to those achieved with 5,000–10,000 IU of urinary hCG.<sup>260,261,262,263,264,265</sup>

The availability of recombinant FSH, LH, and hCG has done much to further our understanding of the specific actions of individual gonadotropins in follicular development and oocyte maturation.<sup>266,267,268</sup> Recombinant gonadotropins provide the capability to tailor ovarian stimulation regimens to the needs of the individual woman in an effort to optimize oocyte quality and cycle fecundity. Unfortunately, we still do not yet have the ability to accurately define what those specific needs are. It may someday be possible to design combinations of recombinant gonadotropins that will vary with the hormonal milieu of the individual, perhaps even within a cycle of stimulation, but for the present, our existing more generic treatment regimens must suffice.

# Indications for Gonadotropin Treatment

Any discussion of ovulation induction with exogenous gonadotropins must first define the different clinical situations in which they may be used because the choice of gonadotropin preparation and treatment regimen vary with the type of ovulatory disturbance.

## Hypogonadotropic Hypogonadism

Women with hypogonadotropic hypogonadism (hypothalamic amenorrhea, WHO Group I) are the most obvious candidates for ovulation induction with exogenous gonadotropins. Oral antiestrogens typically are ineffective because their actions require an intact and functional hypothalamic-pituitary-ovarian axis. In a sense, gonadotropin therapy in women with hypogonadotropic hypogonadism may be viewed as hormone therapy intended to stimulate normal folliculogenesis and ovulation once fertility becomes a priority.

**In women with hypogonadotropic hypogonadism, ovulation induction regimen must contain both FSH and LH.** Although follicular growth and oocyte maturation can be successfully stimulated with FSH alone,<sup>269</sup> LH also is required for normal steroidogenesis, luteinization, and ovulation<sup>257,270,271,272,273</sup>; endogenous LH levels typically are inadequate. Traditionally, menotropins are the drug of choice. One small randomized controlled trial including 35 women with hypogonadotropic hypogonadism compared 150 IU/day of menotropin with a combination of 150 IU/day of rFSH and 75 IU/day of rLH.<sup>274</sup> Following three cycles, ovulation rates were similar with hMG and rFSH/rLH combination (88% vs. 70%), but women receiving rFSH/rLH combination had higher pregnancy rates (23.3% vs. 55.6%). The study has multiple limitations, that is, lack of sample size calculation, blinding, unclear allocation concealment, and inclusion of each woman with more than one cycle, and as such should be regarded as providing low-quality evidence. The multiple pregnancy rate was 5/25 (20%) in this study using a starting dosage of 150 IU/day. **Women with hypogonadotropic hypogonadism may respond to relatively low doses of gonadotropin stimulation, although treatment must nonetheless be carefully monitored and adjusted according to response. The objective, unifollicular ovulation, must be kept clearly in mind because hypogonadal women are otherwise normally fertile and at high risk for multiple pregnancy.**

The quality of luteal function after exogenous gonadotropin-induced ovulation in women with hypogonadotropic hypogonadism merits specific consideration. **Although not always required,<sup>275</sup> luteal phase support with supplemental hCG (2,000–2,500 IU every 3–4 days)<sup>276</sup> or progesterone<sup>277</sup> generally is needed to compensate for low**



**levels of endogenous LH secretion that can prove insufficient to support normal luteal function.** Premenstrual spotting or a grossly short luteal phase suggests the possibility. Some have observed that supplemental hCG treatment can improve cycle fecundity,<sup>276,278</sup> but its value has not been conclusively demonstrated, probably because endogenous LH levels vary in women with hypogonadotropic hypogonadism and only those with profoundly low LH concentrations (< approximately 3 IU/L) may benefit from luteal phase support.<sup>257,279</sup> Because supplemental hCG also increases the risk for OHSS, treatment with hCG is best reserved for women who exhibit evidence of poor luteal function after ovulation induction; empiric treatment with progesterone is the obvious alternative.

Some women with secondary hypogonadotropic hypogonadism related to hyperprolactinemia become candidates for treatment with exogenous gonadotropins because they cannot tolerate dopamine agonist therapy. Consequently, it is important to know that hyperprolactinemia has no apparent adverse effect on the response to exogenous gonadotropins.<sup>280</sup>

## **Oral Antiestrogen-Resistant Anovulation**

When oral antiestrogen treatments such as clomiphene or aromatase inhibitors fail to achieve ovulation, exogenous gonadotropins are an obvious option. Any of the alternative and adjuvant therapies discussed above also might be chosen in efforts to avoid the costs, logistical demands, and risks of gonadotropin treatment, but failure with other such strategies is not a prerequisite for the use of gonadotropins.

In women with hypogonadotropic hypogonadism, endogenous gonadotropin secretion is extremely low, and menotropin (hMG) therapy provides the necessary gonadotropin stimulation. In contrast, serum gonadotropin concentrations in oral antiestrogen-resistant anovulatory women with PCOS (WHO Group II) generally are normal and, in many, LH levels are relatively high. In this population of women, treatment with exogenous gonadotropins is superimposed on a background of erratic endogenous FSH and LH secretion. Purified or recombinant FSH preparations offer a theoretical advantage over conventional menotropins because they avoid the risk of amplifying endogenous LH hypersecretion. However, in practice, there is no evidence that purified or recombinant FSH has greater efficacy than hMG and either may be used. Numerous randomized controlled trials have compared urinary FSH, recombinant FSH, and hMG for ovulation induction in clomiphene-resistant anovulatory women with PCOS. A meta-analysis including 14 such trials found no differences in the ovulation rate, pregnancy rate, miscarriage rate, multiple pregnancy rate, or incidence of OHSS.<sup>281</sup>

Like women with hypogonadotropic hypogonadism, clomiphene-resistant

anovulatory women with PCOS generally respond to relatively low doses of gonadotropin stimulation. **In many who are exquisitely sensitive, the therapeutic range is extremely narrow; doses that are only slightly higher than those proving ineffective can cause hyperstimulation.** Treatment again must be carefully monitored and frequently requires small adjustments. Unifollicular ovulation remains the objective but often can be difficult to achieve. The risk for multiple pregnancy is high and risk of ovarian hyperstimulation is greater than in hypogonadal women.

Luteal phase support seldom is necessary after gonadotropin-induced ovulation in women with PCOS because endogenous LH levels typically are more than sufficient to support normal luteal function. However, in women also receiving treatment with a GnRH agonist to suppress endogenous gonadotropin secretion (discussed below)<sup>282</sup> and in others who may exhibit evidence of poor luteal function after otherwise successful ovulation induction, luteal phase support generally should be provided; considering the higher risk of OHSS associated with hCG, progesterone therapy is preferable.<sup>241,283</sup>

## Unexplained Infertility

Exogenous gonadotropins can be used intentionally to stimulate the development and ovulation of more than one mature ovum in efforts to increase cycle fecundity in older subfertile women and those with otherwise unexplained infertility; superovulation is most effective when combined with timely IUI ([Chapter 25](#)). In this context, higher initial daily doses of exogenous gonadotropins are typically employed,<sup>282</sup> and because such women already ovulate normally and have no endocrinopathy, any of the available gonadotropin preparations can be used. Although superovulation is intended, careful monitoring is still required to avoid obviously excessive stimulation. The risk of multiple pregnancy is even greater than with ovulation induction in clomiphene-resistant anovulatory women, not surprising considering that superovulation is specifically intended. A 2017 meta-analysis including 11 trials found that luteal support with vaginal progesterone increased clinical pregnancy (RR = 1.56, 95% CI = 1.21–2.02) and live birth rates (RR = 1.77; 95% CI = 1.30–2.42) significantly.<sup>284</sup>

# Gonadotropin Treatment Regimens

Careful counseling and instruction are essential to the success of gonadotropin treatment. Couples must be thoroughly familiar with the medications prescribed, the methods for their preparation and injection, the need for frequent office visits to monitor response and reliable lines of communication, and the costs, prognosis, and risks associated with exogenous gonadotropin therapy.

Early retrospective studies established that daily treatment, frequently adjusted according to the clinical response, is the most effective treatment regimen.<sup>285,286</sup> The dose and duration of gonadotropin treatment required to induce ovulation successfully vary among women, sometimes even among cycles within women, and must be determined empirically. Whereas many women are extremely sensitive to relatively low doses of gonadotropins (75 IU daily), others require substantially greater stimulation (300–450 IU daily). Although there is a direct relationship between body weight and dose requirement, the response threshold for a specific individual cannot be predicted reliably, even in the obese.<sup>287</sup> The treatment plan also must consider the intended goal, unifollicular ovulation, or purposeful superovulation. **Safe and effective ovulation induction with exogenous gonadotropins depends heavily on the experience and clinical judgment of the treating clinician.**

In both women with hypogonadotropic hypogonadism (WHO Group I) and those with oral antiestrogen-resistant anovulation (WHO Group II), initial attempts to induce ovulation generally should begin with a low daily dose (75 IU daily) in a “**step-up**” **treatment regimen** designed to define the effective threshold of response. After 4–7 days of stimulation, a serum estradiol level, with or without transvaginal ultrasonography, provides the first measure of response. Thereafter, the dose of gonadotropins may be maintained or increased, as indicated. Once the serum estradiol level begins to rise, ovarian ultrasonography to determine the number and size of developing follicles becomes essential and the frequency of evaluation increases to every 1–2 days. When the mean diameter of the lead follicle reaches 16–18 mm, hCG is administered to trigger ovum release; ovulation generally may be expected to occur approximately 36–48 hours later. In subsequent stimulation cycles, the initial dose of gonadotropins should consider the response threshold and pattern of follicular development observed in previous cycles.

Because women with PCOS often are exquisitely sensitive to low doses of gonadotropin stimulation, early and frequent monitoring generally is wise. Such women typically have a larger number of small antral follicles (recruitable follicles) poised to respond to FSH stimulation.<sup>288</sup> Ovarian hyperstimulation, higher risks of multiple pregnancy, and the expense and frustration associated with canceled cycles usually can

be avoided by using a **“low-slow” treatment regimen** involving low doses (37.5–75 IU daily), small increments, and a longer duration of stimulation.<sup>289,290,291,292,293</sup> Although most gonadotropin stimulations span an interval of 7–12 days, low-dose stimulations in women with PCOS can take longer. Insulin-resistant women may be less sensitive to gonadotropin stimulation than those who have normal insulin response.<sup>294</sup> In some such women, metformin treatment before and during gonadotropin stimulation can help to improve response, limit the number of smaller developing ovarian follicles,<sup>295</sup> and reduce the likelihood of cycle cancellation for excessive stimulation.<sup>165</sup>

The alternative **“step-down” treatment regimen** is designed to more closely approximate the pattern of serum FSH concentrations observed in spontaneous ovulatory cycles. Treatment begins with a higher dose (150–225 IU daily) and decreases gradually thereafter in an effort to promote continued development of only the more sensitive dominant follicle while withdrawing support from the less sensitive smaller follicles in the cohort. Considering that many anovulatory women are quite sensitive to low doses of exogenous gonadotropin stimulation, the step-down method generally is best applied only after the response threshold has been established in one or more previous stimulation cycles. However, the two approaches can be effectively combined, first gradually increasing the dose of gonadotropins until a response is observed and then decreasing the dose once a dominant follicle has emerged.

Recognition of the role that LH plays in the latter stages of follicular development, when FSH levels decline steadily, has suggested other approaches to ovulation induction with gonadotropins that may have particular value for women with PCOS, in whom standard treatment regimens too often result in multifollicular development and ovarian hyperstimulation. Although the selected dominant follicle is more sensitive to FSH than smaller follicles in the cohort, by virtue of its greater granulosa cell mass, FSH receptor content, and advanced microvascular development, the final stages of maturation are equally, if not more, dependent on low levels of LH.<sup>267,268,296,297</sup> Whereas LH stimulates the theca (to produce androgens as substrate for estrogen synthesis) in all follicles, it also stimulates granulosa cells in larger follicles, via LH receptors induced by FSH and estrogen.<sup>298,299,300,301</sup> LH thus becomes the principal stimulus for the final stages of follicular maturation while declining concentrations of FSH starve the smaller, more FSH-dependent follicles into atresia.

Low doses of hCG<sup>302</sup> or recombinant LH<sup>257</sup> can selectively promote larger follicle growth while also hastening the regression of smaller follicles. To a limited extent, step-down gonadotropin treatment regimens, in which the amounts of FSH stimulation are gradually reduced, have exploited this phenomenon. The practice of “coasting,” wherein FSH stimulation is withdrawn altogether during the latter stages of follicle development, does so even more. In the latter instance, the largest follicles generally

continue to function, most likely because their LH receptor expression renders them receptive to prevailing low concentrations of endogenous LH,<sup>303</sup> whereas estrogen levels plateau or decline and smaller follicles arrest or begin to regress.<sup>304,305</sup> Continuing stimulation with low doses of hCG or recombinant LH after decreasing or discontinuing FSH treatment takes fullest advantage of the differential actions of LH in larger and smaller follicles by supporting continued development of the former<sup>267,297</sup> and selectively excluding the latter,<sup>296,306</sup> both by withdrawing FSH and by directly stimulating increased intrafollicular androgen concentrations.<sup>307</sup>

In women with hypogonadotropic hypogonadism or PCOS, recombinant LH treatment (225–450 IU daily) during the latter stages of follicular development can decrease the number of developing follicles.<sup>306</sup> In GnRH agonist-suppressed normal ovulatory women treated with 150 IU FSH daily for 7 days, a variety of treatment regimens involving combinations of decreasing FSH (50, 25, 0 IU) and increasing hCG (50, 100, 200 IU) have been observed to support the development of larger follicles and to speed the regression of smaller follicles.<sup>308</sup> Whereas either hCG or recombinant LH might be used, the longer half-life of hCG may help to provide a more stable level of LH activity between daily injections.<sup>308</sup> Interestingly, low-dose hCG treatment during the late stages of follicular development appears to have little effect on circulating progesterone or testosterone concentrations, at least in normal women, suggesting that the risk of causing premature luteinization or other adverse effects is low. By inducing the regression of smaller follicles, such treatment also may help to reduce the risk of ovarian hyperstimulation associated with exogenous gonadotropin therapy. The optimum sequence and relative amounts of FSH and LH/hCG to administer have not been defined and likely vary with the goals of treatment and the endocrinology of individual women.<sup>306,309,310</sup>

Some clomiphene-resistant anovulatory women can benefit from **sequential treatment with clomiphene and gonadotropins**. The typical cycle involves a standard course of clomiphene treatment (50–100 mg daily), followed by low-dose FSH or hMG (75 IU daily) beginning on the last day of clomiphene therapy or the next day; treatment is monitored and individualized thereafter as in standard gonadotropin-stimulated cycles. In most,<sup>311,312,313</sup> but not all studies,<sup>314</sup> cycle fecundity in sequential treatment cycles has approached or equaled that achieved with gonadotropins alone. In all, the dose and duration of gonadotropin therapy and the associated costs of monitoring were decreased significantly by 50% or more. Logically, sequential therapy generally is useful only in women who respond to clomiphene, at least to some extent. Otherwise, treatment does not effectively begin until gonadotropin therapy starts.

The elevated endogenous LH levels in many clomiphene-resistant anovulatory women with PCOS predispose to premature follicular luteinization during exogenous

gonadotropin stimulation<sup>282,315,316</sup> and have been implicated as a contributing factor in the higher incidence of spontaneous miscarriage observed in those who conceive.<sup>317,318,319,320</sup> **Adjuvant treatment with a long-acting GnRH agonist** before exogenous gonadotropin stimulation suppresses endogenous LH levels, and continued GnRH agonist treatment during gonadotropin stimulation can prevent premature luteinization.<sup>282,316,321</sup> The risk that residual GnRH agonist-induced LH suppression might result in poor luteal function after ovulation induction appears more theoretical than real.<sup>322</sup>

Nonrandomized clinical trials have suggested that combined treatment with a GnRH agonist and exogenous gonadotropins can improve cycle fecundity in clomiphene-resistant anovulatory women.<sup>316,321,323</sup> However, randomized controlled trials comparing combined treatment with a GnRH agonist and exogenous gonadotropins to stimulation with gonadotropins alone have failed to demonstrate any differences in cycle fecundity or the incidence of ovarian hyperstimulation.<sup>282,322,324,325</sup> Adjuvant GnRH agonist therapy also has no proven benefits for unselected subfertile women receiving gonadotropins to induce superovulation<sup>326</sup> and may even increase the amount and duration of gonadotropin stimulation required, at least in some.<sup>282,324</sup> **Although combined treatment with a GnRH agonist/antagonist and exogenous gonadotropins is the established standard for controlled ovarian hyperstimulation in IVF cycles, it has no proven advantage over gonadotropin stimulation alone for ovulation induction.**

# Monitoring Gonadotropin Therapy

To achieve ovulation but also avoid ovarian hyperstimulation and minimize the risk for multiple pregnancy, gonadotropin therapy must be carefully monitored with serial serum estradiol measurements and transvaginal ultrasonography. In effect, the clinician replaces the hypothalamus and pituitary in the feedback loop during treatment with exogenous gonadotropins. The chosen dose is administered, the ovarian response is measured and judged according to needs and expectations, and the gonadotropin dose is maintained or adjusted, reevaluated, and readjusted as needed. Under normal circumstances, the hypothalamic-pituitary-ovarian axis performs the same task, constantly and repeatedly refining and coordinating the level of gonadotropin stimulation with the ovarian response. By contrast, the clinician can make no more than one such assessment daily, at most. Not surprisingly, the results achieved are relatively crude by comparison.

## Serum Estradiol Levels

To best reflect the ovarian response to stimulation and provide for an efficient flow of information, gonadotropins generally are administered in the evening, typically between 5:00 and 8:00 P.M., and serum estradiol measurements are obtained early in the morning. Results usually are available for review by midday, and new instructions regarding the dose and duration of treatment and the next scheduled evaluation are communicated before the evening dose of that day is due. In general, follicles less than approximately 10 mm in mean diameter produce relatively little measurable estrogen, and larger follicles secrete progressively more as they grow and approach maturity. Usually, estradiol levels rise at a constant exponential pace, doubling approximately every 2–3 days over the days before peak follicular development is achieved. A shallower or steeper slope of increase suggests the need to increase or decrease the level of stimulation.

In the natural ovulatory cycle, estradiol levels peak between 200 and 400 pg/mL just before the LH surge. Comparable levels of estradiol should be expected in gonadotropin-stimulated cycles, for each mature follicle observed. Clinical judgments also must consider the number and size of smaller follicles and their lesser but collective contributions to the serum estradiol concentration. **Not surprisingly, cycle fecundability increases with serum estradiol levels; unfortunately, so do the risks of multiple pregnancy and ovarian hyperstimulation. With existing gonadotropin stimulation regimens, best results generally are obtained when estradiol concentrations peak between 500 and 1,500 pg/mL; pregnancies are uncommon at levels below 200 pg/mL.** <sup>327,328,329,330,331</sup>

## Ultrasonography

Ovarian ultrasonography defines the size and number of follicles contributing to the measured estradiol level. In the normal ovulatory cycle, the recruited cohort of antral follicles can be identified by cycle days 5–7, and the dominant follicle emerges by days 8–12, grows approximately 1–3 mm/day thereafter (most rapidly over the 1–2 days immediately preceding ovulation), and measures approximately 20–24 mm in mean diameter when the LH surge occurs; lesser follicles rarely exceed approximately 14 mm in diameter.<sup>95,96</sup> In 5–10% of spontaneous cycles, two preovulatory follicles may develop.

In exogenous gonadotropin-stimulated cycles, dominant follicles exhibit a similar linear growth pattern but reach maturity at a smaller mean diameter and over a wider range of sizes. **The likelihood of ovulation increases with follicular diameter.** As judged by serial ultrasonography after hCG administration, follicles 14 mm and smaller occasionally ovulate, but about 40% of those measuring 15–16 mm, 70% measuring 17–18 mm, 80% measuring 19–20 mm in size, and virtually all larger follicles will ovulate.<sup>332</sup> The larger range of follicle size at maturity complicates clinical judgments. **The risk of multiple gestation rises with the number of follicles likely to ovulate. Consequently, hCG generally should not be administered when the risk of multiple ovulation is high and the goal of treatment is unifollicular ovulation.** A large number of intermediate and small follicles also increase the risk for OHSS.<sup>333</sup>

Baseline ovarian ultrasonography is prudent between consecutive cycles of stimulation with exogenous gonadotropins. In the absence of any significant residual ovarian cysts or gross enlargement, treatment can begin again immediately without the need for an intervening rest cycle. Higher cycle fecundability and cumulative pregnancy rates have been observed in consecutive treatment cycles than with alternating cycles of stimulation and no treatment.<sup>334,335</sup> When baseline ultrasonography reveals one or more residual ovarian cysts, it is usually best to briefly postpone further treatment. Stimulation cycles in the presence of ovarian cysts are less often successful,<sup>336</sup> possibly because newly emerging follicles can be difficult to distinguish from regressing cystic follicles, leading to errors in interpretation. Although many believe that suppressive therapy with a cycle of oral contraceptives helps to speed the regression of residual ovarian cysts, there is no evidence that such treatment is more successful than observation alone.

Studies of endometrial growth in exogenous gonadotropin-induced ovulatory cycles suggest that ultrasonographic measurements of endometrial thickness also have value. Cycle fecundity increases with endometrial thickness,<sup>337</sup> which correlates with serum estradiol concentrations.<sup>338</sup> While a 2017 systematic review and meta-analysis,



including 23 studies and 3,846 women undergoing ovarian stimulation and IUI, report similar endometrial thickness between women who achieved a pregnancy and who did not,<sup>338</sup> few pregnancies result from cycles in which endometrial thickness is less than approximately 7 mm on the day of hCG-induced ovulation.<sup>328,337,339,340</sup>

# Results of Gonadotropin Treatment

Although exogenous gonadotropin therapy can successfully induce ovulation in over 90% of women with either hypogonadotropic hypogonadism (WHO Group I) or clomiphene-resistant anovulation (WHO Group II), the pregnancy rates achieved in the two populations differ significantly.<sup>234,341,342,343</sup> **In women with hypogonadotropic hypogonadism, cycle fecundity is approximately 25%, equal to or even greater than that observed in normal fertile women; cumulative pregnancy rates after up to six cycles of gonadotropin stimulation approach 90%. By comparison, cycle fecundity is significantly lower in clomiphene-resistant anovulatory women. Overall, cycle fecundity ranges between 5% and 15%, and cumulative conception rates range between 30% and 60%; within the group, those with hyperandrogenic chronic anovulation have the poorest prognosis.**<sup>234,341,342,343,344</sup> Although results generally do not vary with the duration of infertility or parity, pregnancy rates are significantly lower in women 35 years or older than in younger women.<sup>343,344</sup>

**The incidence of multifetal gestation is greatly increased in pregnancies resulting from exogenous gonadotropin-induced ovulation, even in anovulatory women where the goal of treatment is unifollicular ovulation.** Whereas approximately 1 in 80 (1.25%) spontaneous pregnancies and 5–8% of those following clomiphene treatment are multiples,<sup>107,108,109,345</sup> in anovulatory women undergoing gonadotropin-induced ovulation, the rate of multiple pregnancy is reported to be approximately 15%.<sup>341,343</sup> Not surprisingly, the incidence of multiple gestation among subfertile women receiving gonadotropin stimulation for intentional superovulation is even higher and may approach 30% with nearly one-third being high-order multiple pregnancies (approximately 10% overall).<sup>346</sup> The higher frequency of multiple pregnancy after gonadotropin treatment obviously results from inadvertent or intentional multiple ovulation. However, when the cycle is canceled by withholding the hCG injection and abstinence from intercourse, or selective follicular aspiration is undertaken in the presence of multifollicular growth (i.e.,  $\geq 3$  follicles  $\geq 14$ – $16$  mm), multiple pregnancy rates are decreased to 4.4% and 6.5%, while pregnancy rates are maintained between 10% and 14% per stimulation cycle.<sup>347,348</sup> **It is prudent to take necessary measures, including cycle cancellation, to prevent multiple pregnancy in women undergoing ovarian stimulation since they are usually young and have good ovarian reserve, both of which are assuring for a better adjusted response in a subsequent cycle. The complications and costs of high-order multiple pregnancies would be significantly more than the cost and inconvenience associated with forfeited gonadotropin injections.** Interestingly, however, there is some evidence to suggest that the normal frequency of monozygotic twinning (0.3–0.4%)<sup>345</sup> may be

increased as much as threefold in pregnancy resulting from ovulation induction with exogenous gonadotropins.<sup>349</sup>

**The overall incidence of spontaneous miscarriage in gonadotropin-induced conception cycles is approximately 20–25%,<sup>224,341,342,343</sup> moderately higher than is generally observed (15%).** A higher prevalence of advanced maternal age and obesity among women who receive gonadotropin therapy appear to contribute to the higher incidence,<sup>350</sup> but miscarriage rates also differ with the indication for treatment. In general, miscarriage rates are low in those with hypogonadotropic hypogonadism and significantly higher in clomiphene-resistant anovulatory women,<sup>341,342,343</sup> but not in all studies.<sup>234</sup> **As with clomiphene, there is no evidence that gonadotropin therapy is associated with any increased prevalence of congenital anomalies.<sup>351</sup>**

# Risks of Gonadotropin Treatment

In addition to the obviously greater costs and logistical demands involved, exogenous gonadotropin treatment also poses significant risks. Chief among these are the risks of multiple pregnancy and OHSS. Neither can be avoided altogether, even by the most experienced clinician, but both risks can be reduced with careful management. As with any complicated form of treatment having significant intrinsic risks, thorough pretreatment counseling is essential.

## Multiple Pregnancy

Twin births rose by 76% between 1980 and 2009 (from 18.9 to 33.2 per 1,000 births), plateaued between 2009 and 2012, rose to a record high of 33.9 per 1,000 births in 2014, and have been declining since, reaching 33.4 per 1,000 births in 2016.<sup>352</sup> Births of triplet and higher-order multiple pregnancies more than quadrupled between 1980 and 1998 but declined to 101.4 per 100,000 total births in 2016, reaching the lowest level in more than two decades.<sup>352</sup> About 20% of the increase in multiple births, overwhelmingly twins, can be attributed to advanced maternal age and the societal trend toward older age at childbearing (older women are more likely to conceive a multiple pregnancy). The remainder, including almost all high-order multifetal gestations, results directly from the use of exogenous gonadotropins for ovulation induction, superovulation, and ART.<sup>353</sup> The number of multiple pregnancies conceived is even greater because spontaneous and intentional multifetal pregnancy reductions do not appear in birth statistics.

**Multiple pregnancies are high-risk pregnancies at any age because they are frequently complicated by preterm delivery, low birth weight, gestational diabetes, preeclampsia, and associated with high infant morbidity and mortality.**<sup>354,355,356,357</sup>

Their clinical management often requires extended hospitalization, cesarean delivery, and neonatal intensive care; the associated health care costs are enormous, for both individual couples and society. **In fact, evidence indicates that the combined costs associated with multifetal pregnancies and their complications exceed those of all the treatments from which they derive.**<sup>358,359</sup> The less obvious social “costs” associated with multiple births also are high and include increased levels of parental stress, a higher incidence of maternal depression and child neglect or abuse, and a greater likelihood of behavioral problems among siblings.<sup>360</sup> Several factors contribute to the risks of multiple pregnancy associated with exogenous gonadotropin therapy. Although much of the attention in recent years has focused on embryo transfer practices in ART centers, less than half of all treatment-related multiple pregnancies results from IVF.<sup>361,362</sup> The majority of multiple pregnancies, and the focus here, results from

exogenous gonadotropin therapy for ovulation induction and superovulation.

Exogenous gonadotropins are an essential part of the therapeutic armamentarium with specific indications, and very real risks, including multiple pregnancy. **Gonadotropins should be reserved for ovulation induction in infertile women with hypogonadotropic hypogonadism and oral antiestrogen-resistant anovulation and for intentional superovulation in subfertile women and those with otherwise unexplained infertility, including women who ovulate in response to treatment but ultimately fail to conceive.** If unnecessary risk is to be avoided, the objective (unifollicular ovulation vs. intentional superovulation) must be kept clearly in mind; there is seldom an indication for superovulation in anovulatory but presumably otherwise fertile women.

Many infertile women seek the most aggressive forms of treatment simply because they offer the greatest chance for success, finding it hard to believe that any treatment could be too successful. Even those committed to avoiding excessive risks can find it very difficult to accept recommendations to cancel a treatment cycle, thereby forfeiting their investment of time and resources.<sup>363</sup> Financial pressures weigh heavily on the minds of even the most risk-averse patients and physicians. Cost considerations color perspectives and influence treatment decisions, tempting all involved to accept risks they otherwise would choose to avoid and later may regret. Some childless couples actually may hope for twins, but most are more circumspect when thoroughly counseled,<sup>364</sup> and none should want triplets or more.

Multiple pregnancy is an intrinsic risk of intentional superovulation. In IVF cycles, the risk of multiple pregnancy relates to the number of embryos transferred, which the physician and patient control. However, the number of embryos that may implant is difficult to predict or control in superovulation cycles. Logically, risk might be reduced if ovulation simply was not triggered when the estradiol level or number of maturing follicles was excessive. Unfortunately, the response parameters that offer the best balance between increased cycle fecundity and the risks of multiple pregnancy and ovarian hyperstimulation have not been clearly defined and remain controversial.<sup>365,366</sup> **The risk of multiple pregnancy increases with serum estradiol concentrations, with the total number of developing ovarian follicles, and with decreasing maternal age but does not correlate well with the number of larger preovulatory follicles.**<sup>49,346,367,368,369,370</sup> Some have suggested varying cycle cancellation criteria that might be used to guide treatment and limit risks of multiple pregnancies.<sup>346,367,368</sup> Whereas there is little doubt that withholding hCG when serum estradiol levels rise above approximately 900–1,400 pg/mL or ultrasonography reveals more than four to six follicles larger than 10–14 mm, or more than three follicles  $\geq 15$  mm, application of such criteria also would dictate cancellation up to one-third of all exogenous gonadotropin-

stimulated cycles.<sup>105,370</sup>

With relatively few exceptions among anovulatory women, exogenous gonadotropin therapy can be refined to achieve unifollicular ovulation with limited risk of multiple pregnancy and minimal risk of high-order multiple pregnancy. Conservative superovulation strategies likely can reduce the risk of multiple pregnancy associated with gonadotropin treatment, but any therapy wherein the specific objective is multifollicular ovulation logically cannot avoid the consequence. It is important to acknowledge that superovulation treatment exists primarily because practical considerations effectively prevent so many from pursuing the obvious alternative of IVF. In all likelihood, superovulation would fade into obsolescence if IVF was available to all those who need it, and few physicians or patients would lament its passing.

When ovarian stimulation exceeds its targeted goals, management options other than cycle cancellation include conversion to IVF and transvaginal aspiration of “excess” follicles. Unfortunately, the first of these is available only in centers where IVF also is offered. While, based on limited evidence, “rescue” IVF can provide equally good clinical outcome with “regular” IVF,<sup>371,372,373</sup> most couples are unprepared for the change in plan and the substantial additional costs involved. Limited experience with the second option of aspirating excess follicles before hCG is administered to prevent ovulation of more than three ova suggests the strategy can effectively reduce the risk of multiple pregnancy and may be a legitimate alternative to cycle cancellation.<sup>374,375</sup>

## **Multifetal Pregnancy Reduction**

Women who conceive a high-order multiple pregnancy despite all efforts to avoid the complication must choose from among three difficult options. Termination of the entire pregnancy generally is unacceptable, particularly for those who have overcome infertility. Continuing the pregnancy carries the inherent risks of preterm birth and associated complications of increased neonatal morbidity and mortality and longer-term disability. Multifetal pregnancy reduction sacrifices a portion of the pregnancy in efforts to save the whole, but for many, it is no option at all, for a variety of personal, moral, ethical, or religious reasons. For most, a choice between the risks of carrying a high-order multiple pregnancy and those associated with pregnancy reduction presents a most difficult dilemma. Couples that ultimately choose pregnancy reduction experience a rapidly shifting tide of strong emotions. Anxiety falls with the diagnosis of pregnancy, rises to very high levels with recognition of a multiple pregnancy, decreases to some extent after consultation before reduction, increases sharply during the procedure, and falls to lower levels after its completion.<sup>376</sup> In retrospect, two-thirds of couples recall acute emotional pain, stress, and fear, and almost 20% report feelings of guilt and anger.<sup>377</sup>

In most cases, multifetal pregnancy reduction is performed under transabdominal ultrasound guidance between 10 and 14 weeks of gestation. By then, the possibility of spontaneous reduction has passed,<sup>378</sup> and a limited screen for gross structural anomalies and features of aneuploidy can be performed to guide selection of fetuses for reduction.<sup>379</sup> There have been no randomized controlled trials comparing maternal and neonatal outcomes in high-order multiple pregnancies managed expectantly with those in which a multifetal reduction was performed, and it is unlikely that there will be.<sup>380</sup> A 2001 report from an international registry including over 3,500 reductions performed at 11 centers indicated that multifetal pregnancy reduction had an overall pregnancy loss rate of nearly 10% with approximately 4% of subsequent deliveries occurring between 25 and 28 weeks of gestation (severe prematurity).<sup>381</sup> Both results compare favorably with published outcomes for series of unreduced high-order multiple pregnancies.<sup>382,383,384,385</sup> Outcomes correlated with the number of fetuses both before and after reduction and improve with the experience of the operator.<sup>386,387</sup> Outcomes were better for triplet pregnancies (6% pregnancy loss rate, 3% severe prematurity) than for quadruplet and higher-order pregnancies (12–22% and 4–11%) and improved as the number of fetuses remaining after reduction decreased from three (20% and 6.5%) to two (9% and 4%) to one (9% and 1.6%).<sup>381</sup> A 2017 systematic review and meta-analysis showed that, when compared with unreduced triplets, reduction from triplets to twins was associated with a significantly lower risk of preterm birth (RR = 0.36, 95% CI = 0.28–0.48) and similar risk of miscarriage (RR = 1.08, 95% CI = 0.58–1.98).<sup>388</sup> Another systematic review of prospective studies comparing outcomes from multifetal pregnancy reduction with those from twin pregnancies (conceived spontaneously or after ART) found no differences between women having a multifetal reduction and women with a twin pregnancy for pregnancy loss (RR = 1.32, CI = 0.42–4.16), preterm birth (before 34 weeks; RR = 0.20, CI = 0.01–3.18), stillbirth (RR = 0.86, CI = 0.05–13.48), or neonatal death (RR = 0.86, CI = 0.05–13.45).<sup>389</sup> Limited available information suggests that reduction to a singleton is associated with fewer pregnancy losses and preterm deliveries than reduction to twins.<sup>390</sup> **Multifetal pregnancy reduction is an effective management tool for the complication of high-order multiple pregnancy, but one which all would prefer to avoid.**

There's very limited information on the outcome of elective reduction from twins to a singleton between 10 and 14 weeks of gestation. Available data suggest that elective reduction to a singleton can be associated with lower rates of preterm delivery less than 37 weeks and low birth weight, however, with similar rates of serious neonatal morbidity or perinatal death, very preterm birth, and small-for-gestational-age live birth, at the cost of an overall increased risk of loss of the entire pregnancy.<sup>391,392</sup>

# Ovarian Hyperstimulation Syndrome

OHSS is an iatrogenic complication of ovulation induction with exogenous gonadotropins. The disorder also can be observed occasionally in clomiphene-induced cycles. However, to date, OHSS is not reported following ovulation induction with letrozole alone. To the contrary, one study including women at high risk of OHSS following ovarian stimulation for IVF reports decreased risk of OHSS when letrozole is given during the luteal phase.<sup>393</sup>

Rare cases of OHSS in spontaneous pregnancies generally have been associated with conditions characterized by supraphysiologic concentrations of hCG (multiple gestations, molar pregnancy). Cases of recurrent OHSS in spontaneous singleton pregnancies in individuals and families have been described and linked to germline mutations in the FSH receptor resulting in the loss of ligand specificity that permits activation by hCG.<sup>394,395,396</sup>

OHSS has a broad pathophysiologic spectrum ranging from mild illness to severe disease. The syndrome normally is self-limited and resolves spontaneously within several days but may persist for longer durations in conception cycles. The hallmark of OHSS is an increase in capillary permeability resulting in a fluid shift from the intravascular to extravascular spaces,<sup>283,397,398</sup> mediated by increased secretion of vasoactive substances including vascular endothelial growth factor (VEGF), elements of the renin-angiotensin system, and other cytokines.<sup>399,400,401,402,403</sup> Resultant hypovolemia leads to hemoconcentration and increased risk of thrombosis.

**Risk factors for OHSS include young age, low body weight, high ovarian reserve as indicated by high serum AMH levels or antral follicle count, PCOS, higher doses of gonadotropins, and previous episodes of hyperstimulation.**<sup>333,404,405,406,407,408,409,410,411</sup> **Risk increases with serum estradiol levels and the number of developing ovarian follicles and when supplemental doses of hCG are administered after ovulation for luteal phase support.**<sup>412,413,414</sup> OHSS has been classified as mild, moderate, severe, or critical but is perhaps best viewed as a continuum with a widely varying number and severity of symptoms.<sup>415</sup>

Mild illness is characterized by ovarian enlargement, lower abdominal discomfort, and mild nausea and vomiting, diarrhea, and abdominal distention and occurs in up to one-third of superovulation cycles.<sup>405</sup> In general, only oral analgesics and counseling to alert affected women to the signs and symptoms of progressive illness are required; intercourse may be painful and is best avoided to limit the risk of ovarian rupture.

Persistent or worsening symptoms or ascites signal progressing illness and require treatment with antiemetics and more potent oral analgesics. Outpatient management



usually is still feasible but must include careful monitoring of daily weights and urinary frequency, serial clinical examinations to detect increasing ascites, and laboratory evaluation of hematocrit, electrolytes, and serum creatinine.<sup>416</sup> Oral fluid intake should be maintained at no less than 1 L/day; electrolyte-supplemented commercial drinks generally are well tolerated and can help to maintain electrolyte balance. Strenuous physical activity is best avoided to reduce the risk of ovarian torsion,<sup>417</sup> but light physical activity is preferable to bed rest, which can increase the risk for thromboembolism. Weight gain greater than approximately 2 lb daily and decreasing urinary frequency are indications for prompt clinical and laboratory reevaluation. **Pregnant women with OHSS merit particularly close monitoring because rapidly rising hCG levels increase the risk for progression to severe illness.** The severity of symptoms, inadequate pain relief, or social considerations may require hospitalization.

Serious illness is uncommon but not rare, having an incidence of approximately 1%. Characteristic features include severe pain, rapid weight gain, tense ascites, hemodynamic instability, respiratory difficulty, progressive oliguria, and laboratory abnormalities. Hypotension can result from vascular volume depletion, oliguria from reduced renal perfusion due to low vascular volume or tense ascites, and dyspnea from ascites or hydrothorax. Hemoconcentration, reduced peripheral perfusion, and inactivity increase the risk of thromboembolism. Renal failure, adult respiratory distress syndrome, hemorrhage from ovarian rupture, and thromboembolic phenomena are potential life-threatening complications of OHSS.<sup>418,419,420,421</sup>

**Hospitalization for more careful monitoring and aggressive treatment warrants serious consideration in women with severe abdominal pain or peritoneal signs, intractable nausea and vomiting, severe oliguria, tense ascites, dyspnea or tachypnea, dizziness or syncope, severe hyponatremia (sodium < 135 mEq/L) or hyperkalemia (potassium > 5 mEq/L), hemoconcentration (hematocrit > 55%), or abnormal renal functions (serum creatinine > 1.2 mg/dL; creatinine clearance < 50 mL/min) or abnormal liver functions (elevated transaminases).**<sup>283,415,416,419,420</sup>

Recommended inpatient care for hospitalized women includes frequent evaluation of vital signs, daily weights, measurements of abdominal circumference and fluid intake and output, chest x-ray and echocardiogram when pleural or pericardial effusion is suspected, pulse oximetry for those with pulmonary symptoms, and serial hematocrits, electrolytes, and renal and liver function studies.<sup>416</sup> Intravenous fluid management must restore an effective plasma volume but not contribute unnecessarily to the accumulation of extravascular fluid. After initial rehydration, fluids should be administered judiciously in the lowest volumes necessary to maintain adequate urine output and relieve hemoconcentration; because of the tendency to develop hyponatremia, saline is preferable to lactated Ringer solution. When saline fails, slow infusions (over 4 hours)

of albumin (25%; 50–100 g at 4–12 hours intervals) can effectively expand plasma volume.<sup>422</sup> Premature or excessive use of diuretics is counterproductive and should be avoided as they cause further volume depletion. Intravenous fluid support can be reduced substantially after diuresis begins and oral intake is reestablished. Hyperkalemia may require specific treatment to move potassium into the intracellular space (insulin/glucose, sodium bicarbonate) or to prevent cardiac dysrhythmias (calcium gluconate).

Ultrasound-guided transabdominal or transvaginal paracentesis can be very helpful in women with painful ascites, pulmonary symptoms, or oliguria that does not respond to fluid management.<sup>421,423,424,425,426</sup> In rare women with persistent bilateral or severe pleural effusions, thoracentesis also may be required to relieve pulmonary symptoms.<sup>427</sup> Full-length venous support stockings are recommended, and prophylactic anticoagulation is warranted in cases of severe OHSS and should be continued at least until the end of the first trimester in case of pregnancy.<sup>428,429</sup> When symptoms prevent ambulation, the use of an intermittent pneumatic compression device can help to reduce the risk of thrombosis. Clinical signs and symptoms suggesting thromboembolism demand prompt additional diagnostic measures and therapeutic anticoagulation when the diagnosis is confirmed or strongly suspected.

In critical cases of OHSS, intensive care may be required for management of thromboembolism, renal failure, or deteriorating pulmonary function. Women with severe hyperstimulation and ovarian torsion or a ruptured ovarian cyst with hemorrhage who require surgical management present a challenge to anesthesiologists who are understandably seldom familiar with the pathophysiology of OHSS.<sup>430</sup>

**Knowledge and prompt recognition of the risk factors for ovarian hyperstimulation are essential for its prevention. Rapidly rising serum estradiol levels, concentrations over 2,500 pg/mL, and observations of a large number of small- and intermediate-sized ovarian follicles are high-risk indicators and signal to cancel or proceed with great caution.** Cycle cancellation and less aggressive stimulation in a subsequent cycle warrant strong consideration. Coasting without further gonadotropin stimulation and delaying administration of hCG for 1–3 days until estradiol levels plateau or decline can reduce the risk of hyperstimulation.<sup>431,432,433,434,435</sup> A lower dose of hCG (5,000 IU) also may help to reduce risk.<sup>283</sup> Alternatively, a GnRH agonist (leuprolide 0.5–1.0 mg) to trigger an endogenous LH surge can be administered,<sup>436</sup> thereby avoiding the longer duration of action and further stimulation of hCG.<sup>437</sup> However, GnRH agonist trigger without any hCG is associated with decreased pregnancy and increased miscarriage risk and does not ensure complete prevention of OHSS.<sup>438</sup> Evidence from a trial involving 69 oocyte

donors at high risk for developing OHSS suggests that treatment with a dopamine agonist (cabergoline 0.5 mg) may decrease vascular permeability (mediated via VEGF) and decrease the risk for OHSS.<sup>439</sup> When luteal support is judged necessary, exogenous progesterone administered by injection (50 mg daily) or vaginally (suppositories 100 mg or 8% gel, daily) are preferable to supplemental doses of hCG.<sup>412</sup>

## **Breast and Ovarian Cancer**

The evidence suggesting that ovulation-inducing drugs might be associated with an increased risk of breast or ovarian cancer was reviewed when discussing the potential risks associated with clomiphene treatment earlier in this chapter. In brief summary, although most studies have found no evidence that fertility drug use increases overall breast cancer risk, some studies suggest that prolonged or repeated use of exogenous gonadotropins (six cycles or more) may increase risk.<sup>135,440,441</sup> Overall, the available data are quite reassuring. **No causal relationship between exogenous gonadotropin treatment and breast or ovarian cancer has been established, although longer-term studies are warranted and prolonged treatment is best avoided, especially when there is little hope for success.**

# PULSATILE GONADOTROPIN-RELEASING HORMONE

---

Exogenous pulsatile GnRH therapy has been used successfully to induce ovulation since 1980.<sup>442,443</sup> Compared to gonadotropin therapy, GnRH treatment has both advantages and disadvantages. Once established, the method is relatively simple to use, requires no extensive and costly monitoring, and is associated with low risks for both multiple pregnancy and ovarian hyperstimulation. However, because GnRH therapy requires maintenance of an indwelling intravenous catheter for an interval of 2–3 weeks or longer, many women fear needle displacement or other technical problems and are reluctant to use the method or reject the option outright. Pulsatile GnRH therapy is currently unavailable in the United States and is not used widely elsewhere in the world.

Where it is available, synthetic GnRH comes in a crystalline form that remains stable for at least 3 weeks at room temperature after reconstitution in aqueous diluent. GnRH is administered in a continuous pulsatile fashion using a portable, programmable mini-pump that must be worn constantly, around the clock, requiring some logistical ingenuity during bathing and sleep. Although the drug may be administered intravenously or subcutaneously, the intravenous route requires lower doses involving less cost (2.5–5.0 vs. 15–20 µg/pulse, depending on body weight) and is more physiologic and more effective. The drug is metabolized rapidly and has a terminal half-life of 10–40 minutes after intravenous administration. Compared to the brief spikes in serum levels that result from intravenous administration and effectively mimic the normal pattern of pulsatile hypothalamic GnRH secretion, subcutaneous treatment creates a more continuous low level of GnRH stimulation without definite peaks.

In effect, pulsatile intravenous exogenous GnRH therapy represents an artificial hypothalamus. In women with hypogonadotropic hypogonadism who have absent or low levels of endogenous pulsatile GnRH secretion, treatment restores a normal pulsatile GnRH rhythm. In those with other forms of ovulatory dysfunction, treatment superimposes a normal rhythm on an existing but disorganized pattern of endogenous GnRH secretion. **Importantly, exogenous pulsatile GnRH treatment generally stimulates only normal physiologic levels of pituitary gonadotropin secretion and allows normal feedback modulation of the pituitary response by ovarian steroids and peptides to operate. Consequently, follicular recruitment, selection, growth, and development in women using the GnRH pump progress as they do in the normal menstrual cycle.**<sup>444,445,446</sup>

# Indications for Pulsatile GnRH Treatment

Anovulatory infertile women with hypogonadotropic hypogonadism are the best candidates for ovulation induction with exogenous GnRH because treatment is specific, physiologic, and highly effective; the GnRH pump provides the only instructional signals the pituitary gonadotropes are likely to receive. Although the drug also can be used in women with other ovulatory disorders, it is much less often effective, probably because the pituitary has more difficulty interpreting the mixed signals of endogenous and exogenous GnRH stimuli. As often may be observed in women with PCOS, an increased BMI (>24), serum LH (>15 IU/L), serum testosterone (> approximately 100 ng/dL), and fasting serum insulin (> approximately 15 units/mL) are associated with lower ovulation rates in response to exogenous GnRH and lower pregnancy rates per ovulatory cycle.<sup>447,448</sup> The GnRH pump also can be effective in women with hyperprolactinemia and offers an alternative to exogenous gonadotropins when dopamine agonist treatment fails or cannot be tolerated.

# Exogenous GnRH Treatment Regimens

**Exogenous GnRH is most effective when administered intravenously in low doses (2.5–5.0 µg/pulse) at a constant interval (every 60–90 minutes).**<sup>447</sup> Those who fail to ovulate may respond to a higher dose (10–20 µg).<sup>449,450</sup> As with oral antiestrogens and exogenous gonadotropins, treatment should begin with a low dose and gradually increase to meet the needs of the individual because the risk of multiple pregnancy increases with the pulse dose.<sup>451</sup> To a large extent, the dose and duration of exogenous GnRH treatment required to induce ovulation depend on the underlying endocrine milieu.<sup>447,452,453</sup>

In women with primary hypogonadotropic hypogonadism, a low dose (2.5 µg/pulse) can induce ovulation effectively, but follicular phase LH concentrations may remain lower than normal and luteal phase progesterone concentrations often are reduced; both are typically normal when a higher dose of GnRH (5.0 µg/pulse) is used. Longer durations of treatment typically are required because available stores of pituitary gonadotropins are markedly reduced due to the historically low levels of endogenous GnRH secretion. In women with secondary idiopathic hypogonadotropic hypogonadism, treatment should begin with a low dose of GnRH (2.5 µg/pulse); the higher dose (5.0 µg/pulse) is associated with higher follicular and luteal phase LH and estradiol levels, a short follicular phase, multiple folliculogenesis, and a higher risk of multiple pregnancy, possibly because previous pituitary or ovarian priming confers a greater sensitivity to GnRH therapy.<sup>447,454</sup>

**The endocrine response of women with PCOS to pulsatile exogenous GnRH (5.0 µg/pulse) is markedly abnormal but can be normalized by pretreatment with a long-acting GnRH agonist (daily subcutaneous administration) for 6–8 weeks immediately before starting pulsatile exogenous GnRH treatment.**<sup>445,447,455</sup> Without GnRH agonist pretreatment, follicular phase FSH, LH, and estradiol levels and luteal phase estradiol concentrations all are abnormally elevated. After preliminary down-regulation with a GnRH agonist, the endocrine characteristics of induced cycles are much improved and closer to those observed in spontaneous ovulatory cycles in normal women. Unless similar down-regulation with a GnRH agonist also precedes subsequent cycles, the response to exogenous GnRH therapy again becomes abnormal. The benefits of GnRH agonist pretreatment probably result from suppression of intraovarian androgen levels<sup>456</sup> and improved (higher) FSH/LH ratios before GnRH therapy begins.<sup>457</sup>

After ovulation has been achieved, GnRH therapy can continue at the same or a slower pulse frequency (every 120–240 minutes).<sup>447,449</sup> Whereas either can stimulate sufficient endogenous LH secretion to support normal corpus luteum function, a slower

frequency more closely approximates the reduced endogenous pulse frequency observed in normal cycles during the luteal phase and may help to reduce the cost of treatment. However, it is simpler, much less costly, and just as effective to discontinue the pump after ovulation has occurred and to support the luteal phase with small doses of hCG (2,000 IU every 3 days)<sup>447</sup> or exogenous progesterone.

One of the advantages that GnRH pump therapy has over exogenous gonadotropin treatment is that monitoring is not required once an effective treatment regimen has been established. Serial estradiol measurements and ovarian ultrasonography certainly can be used to monitor ongoing treatment but are not necessary. Objective evidence of ovulation can be obtained by periodic progesterone measurements. If needed, the time of ovulation can be estimated more accurately by monitoring urinary LH excretion as in spontaneous or clomiphene-induced ovulatory cycles.

# Results of Exogenous GnRH Treatment

A 2018 systematic review and meta-analysis, including 35 studies and 1,002 women with hypothalamic amenorrhea, reported ovulation rates of 75% (95% CI = 64.91–84.44%, based on 3 RCTs) and 85% (95% CI = 81.35–88.68%, based on 32 observational studies).<sup>458</sup> Pooled estimates of pregnancy rate per ovulatory cycle were 38% (95% CI = 14.54–65.85%, 3 RCTs) and 31% (95% CI = 27.77–35.63%, 27 observational studies). Pooled estimates of live birth rates per ovulatory cycle were 35% (95% CI = 15.61–58.12%, 3 RCTs) and 25% (95% CI = 22.27–29.58%, 27 observational studies).<sup>458</sup> **Overall, results are best in women with hypogonadotropic hypogonadism and worse in those with PCOS.**<sup>447,450,459,460</sup> In the former, cycle fecundity equals that observed in normal fertile women, and cumulative pregnancy rates can reach 80% or higher after 6–12 cycles of treatment.<sup>447,449,459,461</sup> In the latter, cycle fecundability and cumulative pregnancy rates are moderately lower, when ovulation can be successfully induced, and pretreatment with a GnRH agonist improves ovulation rates.<sup>447,449,459</sup>

Overall, pulsatile GnRH therapy can achieve ovulation and pregnancy rates that compare with or even exceed those observed with exogenous gonadotropin treatment in women with PCOS,<sup>460</sup> but how the two treatments might compare in eugonadotropic clomiphene-resistant anovulatory women, arguably the more clinically relevant question, is much less clear because no studies have examined their relative efficacy in such a selected population. One small randomized controlled trial in which pulsatile GnRH therapy (10–20 µg/90 minutes) after GnRH agonist suppression (nafarelin 400 mg daily for 3 weeks or longer) was compared directly with clomiphene citrate treatment (50–150 mg daily, cycle days 3–7) as first-line ovulation induction strategy over two to three cycles observed similar ovulation and pregnancy rates in the two groups.<sup>450</sup> These data serve to emphasize again that more complicated and costly ovulation induction regimens involving GnRH pump therapy or exogenous gonadotropin treatment are best reserved for those who fail to ovulate in response to oral antiestrogens.

**In addition to requiring less or no monitoring after an effective treatment regimen has been established, another advantage that pulsatile GnRH therapy has over exogenous gonadotropin treatment is that it rarely results in multiple follicular development and ovulation; the risk for multiple gestation is therefore substantially lower and that for serious ovarian hyperstimulation is eliminated almost entirely.** The aforementioned 2017 systematic review reported a pooled incidence of multiple pregnancy to be 3.35% (95% CI = 0.03–20.44%, 3 RCTs) and 5.67% (95% CI = 3.96–7.8%, 29 observational studies).<sup>458</sup> In the largest single



collected series including over 100 pregnancies in 600 GnRH-stimulated cycles in nearly 300 women with a variety of ovulatory disorders, only four multiple pregnancies (4% incidence, one triplet and three twin pregnancies) and no cases of moderate or severe ovarian hyperstimulation were observed.<sup>447</sup> Overall, the risk of multiple pregnancy in GnRH-induced conception cycles is comparable to that associated with clomiphene treatment (5–8%) and 40–75% lower than that associated with exogenous gonadotropin therapy in anovulatory women (approximately 15%). Based on a meta-analysis of 29 studies including 2,029 cycles, the pooled estimate of incidence of OHSS is 1.86% (95% CI = 0.79–3.37%).<sup>458</sup>

The overall incidence of spontaneous miscarriage in exogenous GnRH-induced conception cycles is approximately 30%.<sup>447,459</sup> As has been observed in most studies of pregnancies resulting from exogenous gonadotropin treatment,<sup>341,342,343</sup> miscarriage rates are lowest in women with hypogonadotropic hypogonadism (<20%) and highest in those with PCOS (over 40%).<sup>445,447,459</sup>

**Taken together, the results achieved with pulsatile exogenous GnRH therapy support its use as the drug of choice for treatment of anovulatory infertile women with hypogonadotropic hypogonadism.<sup>447,459</sup> Unfortunately, few clinicians have experience with the method and relatively few women judge it as an attractive choice after considering the available alternatives.**

# DOPAMINE AGONISTS

---

Hyperprolactinemia and its treatment with dopamine agonists are considered at length elsewhere in this text in the context of their association with amenorrhea ([Chapter 10](#)). Relevant details from that discussion are summarized briefly again here in an expanded discussion focused on the use of dopamine agonists for ovulation induction.

The two most common dopamine agonists in clinical use are bromocriptine and cabergoline. Both are ergot alkaloids that mimic the actions of dopamine via their binding to dopamine receptors. Serum concentrations peak 1–3 hours after an oral dose of bromocriptine, and very little remains in the circulation 14 hours after administration; an oral dose of 2.5 mg generally lowers prolactin concentrations for up to 12 hours.<sup>462</sup> When administered vaginally, the same dose of bromocriptine has peak effects approximately 10–12 hours later that are sustained for up to an additional 12 hours.<sup>463</sup> Cabergoline is a longer-acting dopamine agonist with high affinity for the dopamine receptor. A single dose of cabergoline effectively inhibits prolactin secretion for 7 days or longer.<sup>464</sup>

Like endogenous hypothalamic dopamine, the agonists inhibit pituitary lactotrope prolactin secretion directly. By lowering serum prolactin levels into the normal range, dopamine agonist treatment allows the hypothalamic-pituitary-ovarian axis to escape from the suppressive influence that hyperprolactinemia has on pulsatile GnRH secretion and to resume normal operation, thereby restoring ovulatory function. Because even prolactin-secreting pituitary adenomas remain sensitive to the actions of dopamine, the agonists are effective in hyperprolactinemic women with and without a pituitary adenoma.<sup>465</sup>

# Indications for Dopamine Agonist Treatment

**Dopamine agonists are the treatment of choice for hyperprolactinemic infertile women with ovulatory dysfunction who wish to conceive.** Although some hyperprolactinemic women will respond to clomiphene treatment, most do not, because the neuroendocrine consequences of hyperprolactinemia generally disrupt the mechanism by which clomiphene exerts its therapeutic action.

Dopamine agonist treatment can be highly effective in women who have galactorrhea but normal serum prolactin levels.<sup>466</sup> With few exceptions, the presence of galactorrhea can be regarded as a reliable indicator of excess prolactin secretion. Possible explanations for occult hyperprolactinemia include excess production of biologically active forms of prolactin not detected in all immunoassay systems and transient but exaggerated nocturnal prolactin secretion that goes unrecognized in randomly drawn blood samples.<sup>466,467,468,469,470</sup>

Up to 30% of women with PCOS can exhibit mild hyperprolactinemia.<sup>471,472</sup> Reduced levels of dopaminergic inhibition also have been implicated as a contributing cause of the elevated serum LH concentrations observed in women with the disorder.<sup>471,473</sup> Consequently, dopamine agonists also have been advocated as adjuvant therapy for hyperprolactinemic anovulatory women with PCOS who require exogenous gonadotropin treatment. Limited evidence suggests that pretreatment with a dopamine agonist can temper the ovarian response to exogenous gonadotropins and may thereby help to decrease the risks of multiple pregnancy and ovarian hyperstimulation associated with such treatment.<sup>472</sup>

# Dopamine Agonist Treatment Regimens

Because many hyperprolactinemic women are very sensitive to low doses of dopamine agonists, treatment generally should begin with a low dose and increase gradually until the dose required to restore and to maintain euprolactinemia has been established. Although the dose ultimately required roughly correlates with the degree of hyperprolactinemia, many women with very high prolactin levels respond to relatively low doses of dopamine agonists. The dose of dopamine agonist required to maintain euprolactinemia very often is lower than that needed to achieve it initially.<sup>474</sup>

**Cabergoline has widely replaced bromocriptine as the first-choice treatment because it seems more effective in decreasing serum prolactin concentration and has a better side effect profile.** Treatment with cabergoline usually begins with a dose of 0.25 mg twice weekly, increasing gradually thereafter about every 4 weeks until the effective dose is established. Most women achieve normal prolactin levels with 0.5–1.0 mg weekly, and doses greater than 2.0 mg weekly rarely are required.<sup>11,474</sup>

With bromocriptine, treatment usually begins with a dose of 1.25–2.5 mg, administered at bedtime to more effectively suppress the normal nocturnal increase in prolactin secretion. A low initial dose also helps to minimize the frequency and severity of gastrointestinal and cardiovascular side effects related to dopamine receptor stimulation.<sup>475</sup> **Prolactin levels decrease and stabilize shortly after treatment begins, and a repeated serum prolactin measurement will demonstrate the effectiveness of any given dose in as little as a week.** If needed, a second dose can be added, administered with breakfast or lunch. Although most women respond to 2.5–5.0 mg bromocriptine daily, some may require as much as 10 mg daily.<sup>11</sup>

Exogenous gonadotropins are an effective alternative for the few who do not respond to a dopamine agonist, alone or in combination with clomiphene.

# Results of Dopamine Agonist Treatment

**Overall, dopamine agonist treatment normalizes and maintains normal prolactin levels in approximately 60–85% of hyperprolactinemic women. Cyclic menses are restored in 70–90%, usually within 6–8 weeks after treatment begins, and ovulatory cycles return in 50–75% of treated women with or without tumors.**<sup>11,12,474</sup> The probability of successful treatment is modestly lower in women with markedly elevated prolactin levels (>100 ng/mL) than in those with lesser degrees of hyperprolactinemia. Breast secretions typically diminish noticeably within approximately 6 weeks, and complete cessation of galactorrhea generally takes about twice as long to achieve. After discontinuation of dopamine agonist therapy, hyperprolactinemia and associated menstrual dysfunction return in 75–80% of women.

A 2012 systematic review and meta-analysis including nine studies found that cabergoline was more effective than bromocriptine in reducing the risk of persistent hyperprolactinemia (RR = 2.88; 95% CI = 2.20–3.74), amenorrhea/oligomenorrhea (RR = 3.41, 95% CI = 1.40–2.36), and galactorrhea (RR = 3.41, 95% CI = 1.9–5.84).<sup>476</sup> Moreover, cabergoline has proven effective in 70–85% of hyperprolactinemic women who are resistant to or cannot tolerate bromocriptine treatment.<sup>11,474,477</sup> Compliance with a twice weekly treatment (cabergoline) is also better than with a twice-daily regimen (bromocriptine).<sup>11</sup>

# Side Effects of Dopamine Agonists

Overall, side effects of dopamine agonist treatment are common, are most severe during the first 2 weeks of therapy, but generally are well tolerated. Because bromocriptine stimulates both D1 and D2 dopamine receptors, most women will experience mild adrenergic side effects<sup>475</sup>; dizziness, nausea, vomiting, nasal stuffiness, and orthostatic hypotension are the most common. Although cabergoline has similar side effects, they generally are less frequent and severe because of the drug's higher affinity to D2 dopamine receptors. Side effects are severe enough to require discontinuation of treatment in approximately 12% of women treated with bromocriptine and in 3% of those treated with cabergoline.<sup>11,476</sup>

Side effects can be minimized by starting with a low dose, increasing gradually thereafter as needed and tolerated. Taking the medications with a snack or meal also improves tolerance. When necessary, vaginal administration of bromocriptine or cabergoline can help to reduce side effects and improve compliance.<sup>478,479,480</sup> Whereas much of an orally administered dose is not absorbed or rapidly metabolized in the first pass through the liver, vaginal absorption is more complete and avoids immediate hepatic metabolism. Consequently, therapeutic results often can be achieved with lower doses when the drugs are administered vaginally.

# Risks of Dopamine Agonist Treatment

There is no evidence that dopamine agonists pose any increased risk for spontaneous miscarriage or birth defects. Numerous studies of women who have conceived during treatment have found no increase in the incidence of spontaneous miscarriage or congenital anomalies in pregnancies resulting from treatment with bromocriptine<sup>11,481,482,483,484</sup> or cabergoline.<sup>11,463,474,477</sup>

Treatment for Parkinson disease with cabergoline or another dopamine agonist, pergolide, has been associated with a four- to sevenfold increased risk for valvular heart disease (mitral, aortic, or tricuspid regurgitation).<sup>485,486</sup> The risk appears to result from mitogenic stimulation of normally quiescent valve cells via activation of serotonin (5-hydroxytryptamine, 5-HT) receptors (specifically, the 5-HT<sub>2B</sub> receptor).<sup>487</sup> Bromocriptine, which has no 5-HT<sub>2B</sub> agonist activity, has not been associated with any increased risk for valvular heart disease. Although the doses of cabergoline used for treatment of hyperprolactinemia are less than 10% of those used for the treatment of Parkinson disease and have not been associated with the development of heart disease, it seems prudent to use the lowest effective dose of cabergoline for the shortest time required to achieve the goals of treatment. Current evidence does not support a recommendation for echocardiography before or during treatment with low doses of cabergoline in asymptomatic women.

# REFERENCES

1. **Hull MG, Glazener CM, Kelly NJ, Conway DI, Foster PA, Hinton RA, Coulson C, Lambert PA, Watt EM, Desai KM**, Population study of causes, treatment, and outcome of infertility, *Br Med J (Clin Res Ed)* 291:1693, 1985.
2. **Bates GW, Garza DE, Garza MM**, Clinical manifestations of hormonal changes in the menstrual cycle, *Obstet Gynecol Clin North Am* 17:299, 1990.
3. **Practice Committee of the American Society for Reproductive Medicine**, Diagnostic evaluation of the infertile female: a committee opinion, *Fertil Steril* 103:e44, 2015.
4. **Abraham GE, Maroulis GB, Marshall JR**, Evaluation of ovulation and corpus luteum function using measurements of plasma progesterone, *Obstet Gynecol* 44:522, 1974.
5. **Wathen NC, Perry L, Lilford RJ, Chard T**, Interpretation of single progesterone measurement in diagnosis of anovulation and defective luteal phase: observations on analysis of the normal range, *Br Med J (Clin Res Ed)* 288:7, 1984.
6. **Filicori M, Butler JP, Crowley WF Jr**, Neuroendocrine regulation of the corpus luteum in the human. Evidence for pulsatile progesterone secretion, *J Clin Invest* 73:1638, 1984.
7. Agents stimulating gonadal function in the human. Report of a WHO scientific group, *World Health Organ Tech Rep Ser* 514:1, 1973.
8. **Laven JS, Imani B, Eijkemans MJ, Fauser BC**, New approach to polycystic ovary syndrome and other forms of anovulatory infertility, *Obstet Gynecol Surv* 57:755, 2002.
9. **Teede HJ, Misso ML, Costello MF, Dokras A, Laven J, Moran L, Piltonen T, Norman RJ; International PCOS Network**, Recommendations from the international evidence-based guideline for the assessment and management of polycystic ovary syndrome, *Fertil Steril* 110:364, 2018.
10. **Lincoln SR, Ke RW, Kutteh WH**, Screening for hypothyroidism in infertile women, *J Reprod Med* 44:455, 1999.
11. **Webster J, Piscitelli G, Polli A, Ferrari CI, Ismail I, Scanlon MF**, A comparison of cabergoline and bromocriptine in the treatment of hyperprolactinemic amenorrhea. Cabergoline Comparative Study Group, *N Engl J Med* 331:904, 1994.
12. **Cuellar FG**, Bromocriptine mesylate (Parlodel) in the management of amenorrhea/galactorrhea associated with hyperprolactinemia, *Obstet Gynecol* 55:278, 1980.
13. **Thonneau P, Marchand S, Tallec A, Ferial ML, Ducot B, Lansac J, Lopes P, Tabaste JM, Spira A**, Incidence and main causes of infertility in a resident population (1,850,000) of three French regions (1988-1989), *Hum Reprod* 6:811, 1991.
14. **Pasquali R, Antenucci D, Casimirri F, Venturoli S, Paradisi R, Fabbri R, Balestra V, Melchionda N, Barbara L**, Clinical and hormonal characteristics of obese amenorrheic hyperandrogenic women before and after weight loss, *J Clin Endocrinol Metab* 68:173, 1989.
15. **Kiddy DS, Hamilton-Fairley D, Seppala M, Koistinen R, James VH, Reed MJ, Franks S**, Diet-induced changes in sex hormone binding globulin and free testosterone in women with normal or polycystic ovaries: correlation with serum insulin and insulin-like growth factor-I, *Clin Endocrinol (Oxf)* 31:757, 1989.
16. **Guzick DS, Wing R, Smith D, Berga SL, Winters SJ**, Endocrine consequences of weight loss in obese, hyperandrogenic, anovulatory women, *Fertil Steril* 61:598, 1994.
17. **Andersen P, Seljeflot I, Abdelnoor M, Arnesen H, Dale PO, Lovik A, Birkeland K**, Increased insulin sensitivity and fibrinolytic capacity after dietary intervention in obese women with polycystic ovary syndrome, *Metabolism* 44:611, 1995.
18. **Jakubowicz DJ, Nestler JE**, 17 alpha-Hydroxyprogesterone responses to leuprolide and serum androgens in obese women with and without polycystic ovary syndrome offer dietary weight loss, *J Clin Endocrinol Metab* 82:556, 1997.
19. **Clark AM, Ledger W, Galletly C, Tomlinson L, Blaney F, Wang X, Norman RJ**, Weight loss results in significant improvement in pregnancy and ovulation rates in anovulatory obese women, *Hum Reprod* 10:2705,



1995.

20. **Hollmann M, Runnebaum B, Gerhard I**, Effects of weight loss on the hormonal profile in obese, infertile women, *Hum Reprod* 11:1884, 1996.
21. **Legro RS, Dodson WC, Kris-Etherton PM, Kunselman AR, Stetter CM, Williams NI, Gnatuk CL, Estes SJ, Fleming J, Allison KC, Sarwer DB, Coutifaris C, Dokras A**, Randomized controlled trial of preconception interventions in infertile women with polycystic ovary syndrome, *J Clin Endocrinol Metab* 100:4048, 2015.
22. **Legro RS, Brzyski RG, Diamond MP, Coutifaris C, Schlaff WD, Casson P, Christman GM, Huang H, Yan Q, Alvero R, Haisenleder DJ, Barnhart KT, Bates GW, Usadi R, Lucidi S, Baker V, Trussell JC, Krawetz SA, Snyder P, Ohl D, Santoro N, Eisenberg E, Zhang H; NICHD Reproductive Medicine Network**, Letrozole versus clomiphene for infertility in the polycystic ovary syndrome, *N Engl J Med* 371:119, 2014.
23. **Legro RS, Dodson WC, Kunselman AR, Stetter CM, Kris-Etherton PM, Williams NI, Gnatuk CL, Estes SJ, Allison KC, Sarwer DB, Diamond MP, Schlaff WD, Casson PR, Christman GM, Barnhart KT, Bates GW, Usadi R, Lucidi S, Baker V, Zhang H, Eisenberg E, Coutifaris C, Dokras A**, Benefit of delayed fertility therapy with preconception weight loss over immediate therapy in obese women with PCOS, *J Clin Endocrinol Metab* 101:2658, 2016.
24. **Kominiarek MA, Jungheim ES, Hoeger KM, Rogers AM, Kahan S, Kim JJ**, American Society for Metabolic and Bariatric Surgery position statement on the impact of obesity and obesity treatment on fertility and fertility therapy Endorsed by the American College of Obstetricians and Gynecologists and the Obesity Society, *Surg Obes Relat Dis* 13:750, 2017.
25. **Skubleny D, Switzer NJ, Gill RS, Dykstra M, Shi X, Sagle MA, de Gara C, Birch DW, Karmali S**, The impact of bariatric surgery on polycystic ovary syndrome: a systematic review and meta-analysis, *Obes Surg* 26:169, 2016.
26. **Christ JP, Falcone T**, Bariatric surgery improves hyperandrogenism, menstrual irregularities, and metabolic dysfunction among women with polycystic ovary syndrome (PCOS), *Obes Surg* 28:2171, 2018.
27. **Escobar-Morreale HF, Santacruz E, Luque-Ramirez M, Botella Carretero JI**, Prevalence of 'obesity-associated gonadal dysfunction' in severely obese men and women and its resolution after bariatric surgery: a systematic review and meta-analysis, *Hum Reprod Update* 23:390, 2017.
28. **Greenblatt RB, Barfield WE, Jungck EC, Ray AW**, Induction of ovulation with MRL/41. Preliminary report, *JAMA* 178:101, 1961.
29. **Dickey RP, Holtkamp DE**, Development, pharmacology and clinical experience with clomiphene citrate, *Hum Reprod Update* 2:483, 1996.
30. **Palomba S, Orio F Jr, Falbo A, Manguso F, Russo T, Cascella T, Tolino A, Carmina E, Colao A, Zullo F**, Prospective parallel randomized, double-blind, double-dummy controlled clinical trial comparing clomiphene citrate and metformin as the first-line treatment for ovulation induction in nonobese anovulatory women with polycystic ovary syndrome, *J Clin Endocrinol Metab* 90:4068, 2005.
31. **Clark JH, Markaverich BM**, The agonistic-antagonistic properties of clomiphene: a review, *Pharmacol Ther* 15:467, 1981.
32. **Mikkelsen TJ, Kroboth PD, Cameron WJ, Dittert LW, Chungi V, Manberg PJ**, Single-dose pharmacokinetics of clomiphene citrate in normal volunteers, *Fertil Steril* 46:392, 1986.
33. **Ernst S, Hite G, Cantrell JS, Richardson A Jr, Benson HD**, Stereochemistry of geometric isomers of clomiphene: a correction of the literature and a reexamination of structure-activity relationships, *J Pharm Sci* 65:148, 1976.
34. **Van Campenhout J, Borreman E, Wyman H, Antaki A**, Induction of ovulation with cisclomiphene, *Am J Obstet Gynecol* 115:321, 1973.
35. **Young SL, Opsahl MS, Fritz MA**, Serum concentrations of enclomiphene and zuclomiphene across consecutive cycles of clomiphene citrate therapy in anovulatory infertile women, *Fertil Steril* 71:639, 1999.
36. **Hsueh AJ, Erickson GF, Yen SS**, Sensitisation of pituitary cells to luteinising hormone releasing hormone by clomiphene citrate in vitro, *Nature* 273:57, 1978.

37. **Kerin JF, Liu JH, Phillipou G, Yen SS**, Evidence for a hypothalamic site of action of clomiphene citrate in women, *J Clin Endocrinol Metab* 61:265, 1985.
38. **Kettel LM, Roseff SJ, Berga SL, Mortola JF, Yen SS**, Hypothalamic-pituitary-ovarian response to clomiphene citrate in women with polycystic ovary syndrome, *Fertil Steril* 59:532, 1993.
39. **Wu CH, Prazak LM**, Endocrine basis for ovulation induction, *Clin Obstet Gynecol* 17:65, 1974.
40. **Adashi EY**, Clomiphene citrate: mechanism(s) and site(s) of action—a hypothesis revisited, *Fertil Steril* 42:331, 1984.
41. **Butzow TL, Kettel LM, Yen SS**, Clomiphene citrate reduces serum insulin-like growth factor I and increases sex hormone-binding globulin levels in women with polycystic ovary syndrome, *Fertil Steril* 63:1200, 1995.
42. **Thompson LA, Barratt CL, Thornton SJ, Bolton AE, Cooke ID**, The effects of clomiphene citrate and cyclofenil on cervical mucus volume and receptivity over the periovulatory period, *Fertil Steril* 59:125, 1993.
43. **Marchini M, Dorta M, Bombelli F, Ruspa M, Campana A, Dolcetta G, Radici E**, Effects of clomiphene citrate on cervical mucus: analysis of some influencing factors, *Int J Fertil* 34:154, 1989.
44. **Roumen FJ**, [Decreased quality of cervix mucus under the influence of clomiphene: a meta-analysis], *Ned Tijdschr Geneesk* 141:2401, 1997.
45. **Tepper R, Lunenfeld B, Shalev J, Ovadia J, Blankstein J**, The effect of clomiphene citrate and tamoxifen on the cervical mucus, *Acta Obstet Gynecol Scand* 67:311, 1988.
46. **Elstein M, Fawcett GM**, Effects of the anti-oestrogens, clomiphene and tamoxifen, on the cervical factor in female infertility, *Ciba Found Symp* 109:173, 1984.
47. **Griffith CS, Grimes DA**, The validity of the postcoital test, *Am J Obstet Gynecol* 162:615, 1990.
48. **Oei SG, Helmerhorst FM, Bloemenkamp KW, Hollants FA, Meerpoel DE, Keirse MJ**, Effectiveness of the postcoital test: randomised controlled trial, *BMJ* 317:502, 1998.
49. **Guzick DS, Carson SA, Coutifaris C, Overstreet JW, Factor-Litvak P, Steinkampf MP, Hill JA, Mastroianni L, Buster JE, Nakajima ST, Vogel DL, Canfield RE**, Efficacy of superovulation and intrauterine insemination in the treatment of infertility. National Cooperative Reproductive Medicine Network, *N Engl J Med* 340:177, 1999.
50. **Guzick DS, Sullivan MW, Adamson GD, Cedars MI, Falk RJ, Peterson EP, Steinkampf MP**, Efficacy of treatment for unexplained infertility, *Fertil Steril* 70:207, 1998.
51. **Asante A, Coddington CC, Schenck L, Stewart EA**, Thin endometrial stripe does not affect likelihood of achieving pregnancy in clomiphene citrate/intrauterine insemination cycles, *Fertil Steril* 100:1610.e1, 2013.
52. **Kolibianakis EM, Zikopoulos KA, Fatemi HM, Osmanagaoglu K, Evenpoel J, Van Steirteghem A, Devroey P**, Endometrial thickness cannot predict ongoing pregnancy achievement in cycles stimulated with clomiphene citrate for intrauterine insemination, *Reprod Biomed Online* 8:115, 2004.
53. **Eden JA, Place J, Carter GD, Jones J, Alagband-Zadeh J, Pawson ME**, The effect of clomiphene citrate on follicular phase increase in endometrial thickness and uterine volume, *Obstet Gynecol* 73:187, 1989.
54. **Randall JM, Templeton A**, Transvaginal sonographic assessment of follicular and endometrial growth in spontaneous and clomiphene citrate cycles, *Fertil Steril* 56:208, 1991.
55. **Haritha S, Rajagopalan G**, Follicular growth, endometrial thickness, and serum estradiol levels in spontaneous and clomiphene citrate-induced cycles, *Int J Gynaecol Obstet* 81:287, 2003.
56. **Check JH, Dietterich C, Lurie D**, The effect of consecutive cycles of clomiphene citrate therapy on endometrial thickness and echo pattern, *Obstet Gynecol* 86:341, 1995.
57. **Bonhoff AJ, Naether OG, Johannisson E**, Effects of clomiphene citrate stimulation on endometrial structure in infertile women, *Hum Reprod* 11:844, 1996.
58. **Sereepapong W, Suwajanakorn S, Triratanachat S, Sampatanukul P, Pruksananonda K, Boonkasemsanti W, Reinprayoon D**, Effects of clomiphene citrate on the endometrium of regularly cycling women, *Fertil Steril* 73:287, 2000.
59. **Sgarlata CS, Mikhail G, Hertelendy F**, Clomiphene and tamoxifen inhibit progesterone synthesis in granulosa cells: comparison with estradiol, *Endocrinology* 114:2032, 1984.
60. **Opsahl MS, Fitz TA, Rexroad CE Jr, Fritz MA**, Effects of enclomiphene and zuclophene on basal and gonadotrophin-stimulated progesterone secretion by isolated subpopulations of small and large ovine luteal cells,

Hum Reprod 11:1250, 1996.

61. **Olsson JH, Nilsson L, Hillensjo T**, Effect of clomiphene isomers on progesterin synthesis in cultured human granulosa cells, Hum Reprod 2:463, 1987.
62. **Schmidt GE, Kim MH, Mansour R, Torello L, Friedman CI**, The effects of enclomiphene and zuclophene citrates on mouse embryos fertilized in vitro and in vivo, Am J Obstet Gynecol 154:727, 1986.
63. **Practice Committee of the American Society for Reproductive Medicine**, Use of clomiphene citrate in infertile women: a committee opinion, Fertil Steril 100:341, 2013.
64. **Practice Committee of the American Society for Reproductive Medicine**, Use of clomiphene citrate in women, Fertil Steril 86:S187, 2006.
65. **Bhattacharya S, Harrild K, Mollison J, Wordsworth S, Tay C, Harrold A, McQueen D, Lyall H, Johnston L, Burrage J, Grossett S, Walton H, Lynch J, Johnstone A, Kini S, Raja A, Templeton A**, Clomifene citrate or unstimulated intrauterine insemination compared with expectant management for unexplained infertility: pragmatic randomised controlled trial, BMJ 337:a716, 2008.
66. **Glazener CM, Coulson C, Lambert PA, Watt EM, Hinton RA, Kelly NG, Hull MG**, Clomiphene treatment for women with unexplained infertility: placebo-controlled study of hormonal responses and conception rates, Gynecol Endocrinol 4:75, 1990.
67. **Meyer WR, Fritz MA**, Empiric clomiphene treatment: when and why, Contemp OB/GYN 40:13, 1995.
68. **Deaton JL, Clark RR, Pittaway DE, Herbst P, Bauguess P**, Clomiphene citrate ovulation induction in combination with a timed intrauterine insemination: the value of urinary luteinizing hormone versus human chorionic gonadotropin timing, Fertil Steril 68:43, 1997.
69. **Strott CA, Cargille CM, Ross GT, Lipsett MB**, The short luteal phase, J Clin Endocrinol Metab 30:246, 1970.
70. **Sherman BM, Korenman SG**, Measurement of serum LH, FSH, estradiol and progesterone in disorders of the human menstrual cycle: the inadequate luteal phase, J Clin Endocrinol Metab 39:145, 1974.
71. **Quagliarello J, Weiss G**, Clomiphene citrate in the management of infertility associated with shortened luteal phases, Fertil Steril 31:373, 1979.
72. **Downs KA, Gibson M**, Clomiphene citrate therapy for luteal phase defect, Fertil Steril 39:34, 1983.
73. **Huang KE**, The primary treatment of luteal phase inadequacy: progesterone versus clomiphene citrate, Am J Obstet Gynecol 155:824, 1986.
74. **Murray DL, Reich L, Adashi EY**, Oral clomiphene citrate and vaginal progesterone suppositories in the treatment of luteal phase dysfunction: a comparative study, Fertil Steril 51:35, 1989.
75. **Guzick DS, Zeleznik A**, Efficacy of clomiphene citrate in the treatment of luteal phase deficiency: quantity versus quality of preovulatory follicles, Fertil Steril 54:206, 1990.
76. **Deaton JL, Gibson M, Blackmer KM, Nakajima ST, Badger GJ, Brumsted JR**, A randomized, controlled trial of clomiphene citrate and intrauterine insemination in couples with unexplained infertility or surgically corrected endometriosis, Fertil Steril 54:1083, 1990.
77. **Abu Hashim H, Ombar O, Abd Elaal I**, Intrauterine insemination versus timed intercourse with clomiphene citrate in polycystic ovary syndrome: a randomized controlled trial, Acta Obstet Gynecol Scand 90:344, 2011.
78. **Wu CH, Winkel CA**, The effect of therapy initiation day on clomiphene citrate therapy, Fertil Steril 52:564, 1989.
79. **Diamond MP, Kruger M, Santoro N, Zhang H, Casson P, Schlaff W, Coutifaris C, Brzyski R, Christman G, Carr BR, McGovern PG, Cataldo NA, Steinkampf MP, Gosman GG, Nestler JE, Carson S, Myers EE, Eisenberg E, Legro RS; Eunice Kennedy Shriver National Institute of Child Health, Human Development Cooperative Reproductive Medicine Network**, Endometrial shedding effect on conception and live birth in women with polycystic ovary syndrome, Obstet Gynecol 119:902, 2012.
80. **Jones CA, Garbedian K, Dixon M, Murphy K, Shapiro H**, Randomized trial comparing the effect of endometrial shedding with medroxyprogesterone acetate with random start of clomiphene citrate for ovulation induction in oligo-ovulatory and anovulatory women, J Obstet Gynaecol Can 38:458, 2016.
81. **Lobo RA, Gysler M, March CM, Goebelsmann U, Mishell DR Jr**, Clinical and laboratory predictors of clomiphene response, Fertil Steril 37:168, 1982.

82. **Lobo RA, Granger LR, Davajan V, Mishell DR Jr**, An extended regimen of clomiphene citrate in women unresponsive to standard therapy, *Fertil Steril* 37:762, 1982.
83. **Hammond MG, Halme JK, Talbert LM**, Factors affecting the pregnancy rate in clomiphene citrate induction of ovulation, *Obstet Gynecol* 62:196, 1983.
84. **Tiitinen AE, Laatikainen TJ, Seppala MT**, Serum levels of insulin-like growth factor binding protein-1 and ovulatory responses to clomiphene citrate in women with polycystic ovarian disease, *Fertil Steril* 60:58, 1993.
85. **Gysler M, March CM, Mishell DR Jr, Bailey EJ**, A decade's experience with an individualized clomiphene treatment regimen including its effect on the postcoital test, *Fertil Steril* 37:161, 1982.
86. **Gorlitsky GA, Kase NG, Speroff L**, Ovulation and pregnancy rates with clomiphene citrate, *Obstet Gynecol* 51:265, 1978.
87. **Dodge ST, Strickler RC, Keller DW**, Ovulation induction with low doses of clomiphene citrate, *Obstet Gynecol* 67:63S, 1986.
88. **Fluker MR, Wang IY, Rowe TC**, An extended 10-day course of clomiphene citrate (CC) in women with CC-resistant ovulatory disorders, *Fertil Steril* 66:761, 1996.
89. **Isaacs JD Jr, Lincoln SR, Cowan BD**, Extended clomiphene citrate (CC) and prednisone for the treatment of chronic anovulation resistant to CC alone, *Fertil Steril* 67:641, 1997.
90. **Miller PB, Soules MR**, The usefulness of a urinary LH kit for ovulation prediction during menstrual cycles of normal women, *Obstet Gynecol* 87:13, 1996.
91. **Opsahl MS, Robins ED, O'Connor DM, Scott RT, Fritz MA**, Characteristics of gonadotropin response, follicular development, and endometrial growth and maturation across consecutive cycles of clomiphene citrate treatment, *Fertil Steril* 66:533, 1996.
92. **Zreik TG, Garcia-Velasco JA, Habboosh MS, Olive DL, Arici A**, Prospective, randomized, crossover study to evaluate the benefit of human chorionic gonadotropin-timed versus urinary luteinizing hormone-timed intrauterine inseminations in clomiphene citrate-stimulated treatment cycles, *Fertil Steril* 71:1070, 1999.
93. **McGovern PG, Myers ER, Silva S, Coutifaris C, Carson SA, Legro RS, Schlaff WD, Carr BR, Steinkampf MP, Giudice LC, Leppert PC, Diamond MP; NICHD National Cooperative Reproductive Medicine Network**, Absence of secretory endometrium after false-positive home urine luteinizing hormone testing, *Fertil Steril* 82:1273, 2004.
94. **Noyes RW, Hertig AT, Rock J**, Dating the endometrial biopsy, *Am J Obstet Gynecol* 122:262, 1975.
95. **de Crespigny LC, O'Herlihy C, Robinson HP**, Ultrasonic observation of the mechanism of human ovulation, *Am J Obstet Gynecol* 139:636, 1981.
96. **Ecochard R, Marret H, Rabilloud M, Bradai R, Boehringer H, Giroto S, Barbato M**, Sensitivity and specificity of ultrasound indices of ovulation in spontaneous cycles, *Eur J Obstet Gynecol Reprod Biol* 91:59, 2000.
97. **Kousta E, White DM, Franks S**, Modern use of clomiphene citrate in induction of ovulation, *Hum Reprod Update* 3:359, 1997.
98. **Smith YR, Randolph JF Jr, Christman GM, Ansbacher R, Howe DM, Hurd WW**, Comparison of low-technology and high-technology monitoring of clomiphene citrate ovulation induction, *Fertil Steril* 70:165, 1998.
99. **Hurst BS, Hickman JM, Matthews ML, Usadi RS, Marshburn PB**, Novel clomiphene "stair-step" protocol reduces time to ovulation in women with polycystic ovarian syndrome, *Am J Obstet Gynecol* 200:510.e1, 2009.
100. **Imani B, Eijkemans MJ, te Velde ER, Habbema JD, Fauser BC**, A nomogram to predict the probability of live birth after clomiphene citrate induction of ovulation in normogonadotropic oligoamenorrheic infertility, *Fertil Steril* 77:91, 2002.
101. **Deveci CD, Demir B, Sengul O, Dilbaz B, Goktolga U**, Clomiphene citrate 'stair-step' protocol vs. traditional protocol in patients with polycystic ovary syndrome: a randomized controlled trial, *Arch Gynecol Obstet* 291:179, 2015.
102. **Imani B, Eijkemans MJ, te Velde ER, Habbema JD, Fauser BC**, Predictors of patients remaining anovulatory during clomiphene citrate induction of ovulation in normogonadotropic oligoamenorrheic infertility, *J Clin Endocrinol Metab* 83:2361, 1998.

103. **Homburg R**, Clomiphene citrate—end of an era? A mini-review, *Hum Reprod* 20:2043, 2005.
104. **Imani B, Eijkemans MJ, te Velde ER, Habbema JD, Fauser BC**, Predictors of chances to conceive in ovulatory patients during clomiphene citrate induction of ovulation in normogonadotropic oligoamenorrhoeic infertility, *J Clin Endocrinol Metab* 84:1617, 1999.
105. **ACOG Committee on Practice Bulletins-Gynecology**, ACOG Practice Bulletin. Clinical management guidelines for obstetrician-gynecologists number 34, February 2002. Management of infertility caused by ovulatory dysfunction. American College of Obstetricians and Gynecologists, *Obstet Gynecol* 99:347, 2002.
106. **Purvin VA**, Visual disturbance secondary to clomiphene citrate, *Arch Ophthalmol* 113:482, 1995.
107. **Schenker JG, Yarkoni S, Granat M**, Multiple pregnancies following induction of ovulation, *Fertil Steril* 35:105, 1981.
108. **Ahlgren M, Kallen B, Rannevik G**, Outcome of pregnancy after clomiphene therapy, *Acta Obstet Gynecol Scand* 55:371, 1976.
109. **Correy JF, Marsden DE, Schokman FC**, The outcome of pregnancy resulting from clomiphene-induced ovulation, *Aust N Z J Obstet Gynaecol* 22:18, 1982.
110. **Reindollar RH, Regan MM, Neumann PJ, Levine BS, Thornton KL, Alper MM, Goldman MB**, A randomized clinical trial to evaluate optimal treatment for unexplained infertility: the fast track and standard treatment (FASTT) trial, *Fertil Steril* 94:888, 2010.
111. **Kurachi K, Aono T, Minagawa J, Miyake A**, Congenital malformations of newborn infants after clomiphene-induced ovulation, *Fertil Steril* 40:187, 1983.
112. **Reefhuis J, Honein MA, Schieve LA, Rasmussen SA; National Birth Defects Prevention Study**, Use of clomiphene citrate and birth defects, National Birth Defects Prevention Study, 1997-2005, *Hum Reprod* 26:451, 2011.
113. **Whiteman D, Murphy M, Hey K, O'Donnell M, Goldacre M**, Reproductive factors, subfertility, and risk of neural tube defects: a case-control study based on the Oxford Record Linkage Study Register, *Am J Epidemiol* 152:823, 2000.
114. **Lammer EJ**, Clomiphene-induced ovulation and the risk of neural tube defects, *Reprod Toxicol* 9:491, 1995.
115. **Carlier P, Choulika S, Efthymiou ML**, [Clomiphene-exposed pregnancies—analysis of 39 information requests including 25 cases with known outcome], *Therapie* 51:532, 1996.
116. **Hack M, Brish M, Serr DM, Insler V, Salomy M, Lunefeld B**, Outcome of pregnancy after induced ovulation. Follow-up of pregnancies and children born after clomiphene therapy, *JAMA* 220:1329, 1972.
117. **Dickey RP, Taylor SN, Curole DN, Rye PH, Pyrzak R**, Incidence of spontaneous abortion in clomiphene pregnancies, *Hum Reprod* 11:2623, 1996.
118. **Legro RS, Barnhart HX, Schlaff WD, Carr BR, Diamond MP, Carson SA, Steinkampf MP, Coutifaris C, McGovern PG, Cataldo NA, Gosman GG, Nestler JE, Giudice LC, Leppert PC, Myers ER; Cooperative Multicenter Reproductive Medicine Network**, Clomiphene, metformin, or both for infertility in the polycystic ovary syndrome, *N Engl J Med* 356:551, 2007.
119. **Tung KH, Wilkens LR, Wu AH, McDuffie K, Nomura AM, Kolonel LN, Terada KY, Goodman MT**, Effect of anovulation factors on pre- and postmenopausal ovarian cancer risk: revisiting the incessant ovulation hypothesis, *Am J Epidemiol* 161:321, 2005.
120. **Whittemore AS, Harris R, Itnyre J**, Characteristics relating to ovarian cancer risk: collaborative analysis of 12 US case-control studies. II. Invasive epithelial ovarian cancers in white women. Collaborative Ovarian Cancer Group, *Am J Epidemiol* 136:1184, 1992.
121. **Rossing MA, Daling JR, Weiss NS, Moore DE, Self SG**, Ovarian tumors in a cohort of infertile women, *N Engl J Med* 331:771, 1994.
122. **Venn A, Watson L, Lumley J, Giles G, King C, Healy D**, Breast and ovarian cancer incidence after infertility and in vitro fertilisation, *Lancet* 346:995, 1995.
123. **Modan B, Ron E, Lerner-Geva L, Blumstein T, Menczer J, Rabinovici J, Oelsner G, Freedman L, Mashiach S, Lunefeld B**, Cancer incidence in a cohort of infertile women, *Am J Epidemiol* 147:1038, 1998.
124. **Potashnik G, Lerner-Geva L, Genkin L, Chetrit A, Lunefeld E, Porath A**, Fertility drugs and the risk of breast and ovarian cancers: results of a long-term follow-up study, *Fertil Steril* 71:853, 1999.

125. **Mosgaard BJ, Lidegaard O, Kjaer SK, Schou G, Andersen AN**, Infertility, fertility drugs, and invasive ovarian cancer: a case-control study, *Fertil Steril* 67:1005, 1997.
126. **Unkila-Kallio L, Tiitinen A, Wahlstrom T, Lehtovirta P, Leminen A**, Reproductive features in women developing ovarian granulosa cell tumour at a fertile age, *Hum Reprod* 15:589, 2000.
127. **Rossing MA, Tang MT, Flagg EW, Weiss LK, Wicklund KG**, A case-control study of ovarian cancer in relation to infertility and the use of ovulation-inducing drugs, *Am J Epidemiol* 160:1070, 2004.
128. **Brinton L**, Long-term effects of ovulation-stimulating drugs on cancer risk, *Reprod Biomed Online* 15:38, 2007.
129. **Kashyap S, Moher D, Fung MF, Rosenwaks Z**, Assisted reproductive technology and the incidence of ovarian cancer: a meta-analysis, *Obstet Gynecol* 103:785, 2004.
130. **Calderon-Margalit R, Friedlander Y, Yanetz R, Kleinhaus K, Perrin MC, Manor O, Harlap S, Paltiel O**, Cancer risk after exposure to treatments for ovulation induction, *Am J Epidemiol* 169:365, 2009.
131. **Rizzuto I, Behrens RF, Smith LA**, Risk of ovarian cancer in women treated with ovarian stimulating drugs for infertility, *Cochrane Database Syst Rev* (8):CD008215, 2013.
132. **Bjornholt SM, Kjaer SK, Nielsen TS, Jensen A**, Risk for borderline ovarian tumours after exposure to fertility drugs: results of a population-based cohort study, *Hum Reprod* 30:222, 2015.
133. **Ness RB, Cramer DW, Goodman MT, Kjaer SK, Mallin K, Mosgaard BJ, Purdie DM, Risch HA, Vergona R, Wu AH**, Infertility, fertility drugs, and ovarian cancer: a pooled analysis of case-control studies, *Am J Epidemiol* 155:217, 2002.
134. **Trabert B, Lamb EJ, Scoccia B, Moghissi KS, Westhoff CL, Niwa S, Brinton LA**, Ovulation-inducing drugs and ovarian cancer risk: results from an extended follow-up of a large United States infertility cohort, *Fertil Steril* 100:1660, 2013.
135. **Brinton LA, Scoccia B, Moghissi KS, Westhoff CL, Niwa S, Ruggieri D, Trabert B, Lamb EJ**, Long-term relationship of ovulation-stimulating drugs to breast cancer risk, *Cancer Epidemiol Biomarkers Prev* 23:584, 2014.
136. **Skalkidou A, Sergeantanis TN, Gialamas SP, Georgakis MK, Psaltopoulou T, Trivella M, Siristatidis CS, Evangelou E, Petridou E**, Risk of endometrial cancer in women treated with ovary-stimulating drugs for subfertility, *Cochrane Database Syst Rev* (3):CD010931, 2017.
137. **Lobo RA, Paul W, March CM, Granger L, Kletzky OA**, Clomiphene and dexamethasone in women unresponsive to clomiphene alone, *Obstet Gynecol* 60:497, 1982.
138. **Daly DC, Walters CA, Soto-Albors CE, Tohan N, Riddick DH**, A randomized study of dexamethasone in ovulation induction with clomiphene citrate, *Fertil Steril* 41:844, 1984.
139. **Trott EA, Plouffe L Jr, Hansen K, Hines R, Brann DW, Mahesh VB**, Ovulation induction in clomiphene-resistant anovulatory women with normal dehydroepiandrosterone sulfate levels: beneficial effects of the addition of dexamethasone during the follicular phase, *Fertil Steril* 66:484, 1996.
140. **Vital Reyes VS, Tellez Velasco S, Hinojosa Cruz JC, Reyes Fuentes A**, [Clomiphene acetate and prednisone: alternative approach for the management of patients with chronic anovulation and clomiphene treatment failure], *Ginecol Obstet Mex* 68:266, 2000.
141. **Parsanezhad ME, Alborzi S, Motazedian S, Omrani G**, Use of dexamethasone and clomiphene citrate in the treatment of clomiphene citrate-resistant patients with polycystic ovary syndrome and normal dehydroepiandrosterone sulfate levels: a prospective, double-blind, placebo-controlled trial, *Fertil Steril* 78:1001, 2002.
142. **Elnashar A, Abdelmageed E, Fayed M, Sharaf M**, Clomiphene citrate and dexamethasone in treatment of clomiphene citrate-resistant polycystic ovary syndrome: a prospective placebo-controlled study, *Hum Reprod* 21:1805, 2006.
143. **Keay SD, Jenkins JM**, Adjunctive use of dexamethasone in Clomid resistant patients, *Fertil Steril* 80:230; author reply 231, 2003.
144. **O'Herlihy C, Pepperell RJ, Robinson HP**, Ultrasound timing of human chorionic gonadotropin administration in clomiphene-stimulated cycle, *Obstet Gynecol* 59:40, 1982.
145. **Martinez AR, Bernadus RE, Voorhorst FJ, Vermeiden JP, Schoemaker J**, A controlled study of human

chorionic gonadotrophin induced ovulation versus urinary luteinizing hormone surge for timing of intrauterine insemination, *Hum Reprod* 6:1247, 1991.

146. **Palatnik A, Strawn E, Szabo A, Robb P**, What is the optimal follicular size before triggering ovulation in intrauterine insemination cycles with clomiphene citrate or letrozole? An analysis of 988 cycles, *Fertil Steril* 97:1089.e1, 2012.
147. **Martinez AR, Bernardus RE, Kucharska D, Schoemaker J**, Urinary luteinizing hormone testing and prediction of ovulation in spontaneous, clomiphene citrate and human menopausal gonadotropin-stimulated cycles. A clinical evaluation, *Acta Endocrinol (Copenh)* 124:357, 1991.
148. **Andersen AG, Als-Nielsen B, Hornnes PJ, Franch Andersen L**, Time interval from human chorionic gonadotrophin (HCG) injection to follicular rupture, *Hum Reprod* 10:3202, 1995.
149. **George K, Kamath MS, Nair R, Tharyan P**, Ovulation triggers in anovulatory women undergoing ovulation induction, *Cochrane Database Syst Rev* (1):CD006900, 2014.
150. **Kosmas IP, Tatsioni A, Fatemi HM, Kolibianakis EM, Tournaye H, Devroey P**, Human chorionic gonadotropin administration vs. luteinizing monitoring for intrauterine insemination timing, after administration of clomiphene citrate: a meta-analysis, *Fertil Steril* 87:607, 2007.
151. **Fritz MA, Hess DL, Patton PE**, Influence of corpus luteum age on the steroidogenic response to exogenous human chorionic gonadotropin in normal cycling women, *Am J Obstet Gynecol* 167:709, 1992.
152. **Agarwal SK, Buyalos RP**, Corpus luteum function and pregnancy rates with clomiphene citrate therapy: comparison of human chorionic gonadotrophin-induced versus spontaneous ovulation, *Hum Reprod* 10:328, 1995.
153. **Nestler JE, Jakubowicz DJ, Reamer P, Gunn RD, Allan G**, Ovulatory and metabolic effects of D-chiro-inositol in the polycystic ovary syndrome, *N Engl J Med* 340:1314, 1999.
154. **Azziz R, Ehrmann D, Legro RS, Whitcomb RW, Hanley R, Fereshetian AG, O'Keefe M, Ghazzi MN; PCOS/Troglitazone Study Group**, Troglitazone improves ovulation and hirsutism in the polycystic ovary syndrome: a multicenter, double blind, placebo-controlled trial, *J Clin Endocrinol Metab* 86:1626, 2001.
155. **Creanga AA, Bradley HM, McCormick C, Witkop CT**, Use of metformin in polycystic ovary syndrome: a meta-analysis, *Obstet Gynecol* 111:959, 2008.
156. **Morley LC, Tang T, Yasmin E, Norman RJ, Balen AH**, Insulin-sensitising drugs (metformin, rosiglitazone, pioglitazone, D-chiro-inositol) for women with polycystic ovary syndrome, oligo amenorrhoea and subfertility, *Cochrane Database Syst Rev* (11):CD003053, 2017.
157. **Practice Committee of the American Society for Reproductive Medicine. Electronic address: ASRM@asrm.org, Practice Committee of the American Society for Reproductive Medicine**, Role of metformin for ovulation induction in infertile patients with polycystic ovary syndrome (PCOS): a guideline, *Fertil Steril* 108:426, 2017.
158. **Baillargeon JP, Jakubowicz DJ, Iuorno MJ, Jakubowicz S, Nestler JE**, Effects of metformin and rosiglitazone, alone and in combination, in nonobese women with polycystic ovary syndrome and normal indices of insulin sensitivity, *Fertil Steril* 82:893, 2004.
159. **Rouzi AA, Ardawi MS**, A randomized controlled trial of the efficacy of rosiglitazone and clomiphene citrate versus metformin and clomiphene citrate in women with clomiphene citrate-resistant polycystic ovary syndrome, *Fertil Steril* 85:428, 2006.
160. **Kaul S, Bolger AF, Herrington D, Giugliano RP, Eckel RH, American Heart A; American College Of Cardiology Foundation**, Thiazolidinedione drugs and cardiovascular risks: a science advisory from the American Heart Association and American College Of Cardiology Foundation, *J Am Coll Cardiol* 55:1885, 2010.
161. **Abu Hashim H, Shokeir T, Badawy A**, Letrozole versus combined metformin and clomiphene citrate for ovulation induction in clomiphene-resistant women with polycystic ovary syndrome: a randomized controlled trial, *Fertil Steril* 94:1405, 2010.
162. **Moggetti P, Castello R, Negri C, Tosi F, Perrone F, Caputo M, Zanolin E, Muggeo M**, Metformin effects on clinical features, endocrine and metabolic profiles, and insulin sensitivity in polycystic ovary syndrome: a randomized, double-blind, placebo-controlled 6-month trial, followed by open, long-term clinical

- evaluation, *J Clin Endocrinol Metab* 85:139, 2000.
163. **Ng EH, Wat NM, Ho PC**, Effects of metformin on ovulation rate, hormonal and metabolic profiles in women with clomiphene-resistant polycystic ovaries: a randomized, double-blinded placebo-controlled trial, *Hum Reprod* 16:1625, 2001.
  164. **Fleming R, Hopkinson ZE, Wallace AM, Greer IA, Sattar N**, Ovarian function and metabolic factors in women with oligomenorrhea treated with metformin in a randomized double blind placebo-controlled trial, *J Clin Endocrinol Metab* 87:569, 2002.
  165. **Yarali H, Yildiz B**, Metformin and FSH for induction of ovulation in women with polycystic ovary syndrome, *Hum Reprod* 17:3007, 2002.
  166. **Salpeter SR, Greyber E, Pasternak GA, Salpeter EE**, Risk of fatal and nonfatal lactic acidosis with metformin use in type 2 diabetes mellitus: systematic review and meta-analysis, *Arch Intern Med* 163:2594, 2003.
  167. **Stades AM, Heikens JT, Erkelens DW, Holleman F, Hoekstra JB**, Metformin and lactic acidosis: cause or coincidence? A review of case reports, *J Intern Med* 255:179, 2004.
  168. **Homburg R**, Pregnancy complications in PCOS, *Best Pract Res Clin Endocrinol Metab* 20:281, 2006.
  169. **Palomba S, Falbo A, Orio F Jr, Manguso F, Russo T, Tolino A, Annamaria C, Dale B, Zullo F**, A randomized controlled trial evaluating metformin pre-treatment and co-administration in non-obese insulin-resistant women with polycystic ovary syndrome treated with controlled ovarian stimulation plus timed intercourse or intrauterine insemination, *Hum Reprod* 20:2879, 2005.
  170. **Palomba S, Orio F Jr, Nardo LG, Falbo A, Russo T, Corea D, Doldo P, Lombardi G, Tolino A, Colao A, Zullo F**, Metformin administration versus laparoscopic ovarian diathermy in clomiphene citrate-resistant women with polycystic ovary syndrome: a prospective parallel randomized double-blind placebo-controlled trial, *J Clin Endocrinol Metab* 89:4801, 2004.
  171. **Glueck CJ, Goldenberg N, Wang P, Loftspring M, Sherman A**, Metformin during pregnancy reduces insulin, insulin resistance, insulin secretion, weight, testosterone and development of gestational diabetes: prospective longitudinal assessment of women with polycystic ovary syndrome from preconception throughout pregnancy, *Hum Reprod* 19:510, 2004.
  172. **Dodd JM, Grivell RM, Deussen AR, Hague WM**, Metformin for women who are overweight or obese during pregnancy for improving maternal and infant outcomes, *Cochrane Database Syst Rev*, 7:CD010564, 2018. doi: 10.1002/14651858.CD010564.pub2.
  173. **Hellmuth E, Damm P, Molsted-Pedersen L**, Oral hypoglycaemic agents in 118 diabetic pregnancies, *Diabet Med* 17:507, 2000.
  174. **Hughes RC, Rowan JA**, Pregnancy in women with Type 2 diabetes: who takes metformin and what is the outcome? *Diabet Med* 23:318, 2006.
  175. **Kalafat E, Sukur YE, Abdi A, Thilaganathan B, Khalil A**, Metformin for the prevention of hypertensive disorders of pregnancy in women with gestational diabetes and obesity: a systematic review and meta-analysis, *Ultrasound Obstet Gynecol* 52(6):706, 2018.
  176. **Gilbert C, Valois M, Koren G**, Pregnancy outcome after first-trimester exposure to metformin: a meta-analysis, *Fertil Steril* 86:658, 2006.
  177. **Branigan EF, Estes MA**, Treatment of chronic anovulation resistant to clomiphene citrate (CC) by using oral contraceptive ovarian suppression followed by repeat CC treatment, *Fertil Steril* 71:544, 1999.
  178. **Branigan EF, Estes MA**, A randomized clinical trial of treatment of clomiphene citrate-resistant anovulation with the use of oral contraceptive pill suppression and repeat clomiphene citrate treatment, *Am J Obstet Gynecol* 188:1424; discussion 1429, 2003.
  179. **Genazzani AD, Battaglia C, Gamba O, Petraglia F, Malavasi B, Genazzani AR**, The use of a combined regimen of GnRH agonist plus a low-dose oral contraceptive improves the spontaneous pulsatile LH secretory characteristics in patients with polycystic ovary disease after discontinuation of treatment, *J Assist Reprod Genet* 17:269, 2000.
  180. **Genazzani AD, Petraglia F, Battaglia C, Gamba O, Volpe A, Genazzani AR**, A long-term treatment with gonadotropin-releasing hormone agonist plus a low-dose oral contraceptive improves the recovery of the



ovulatory function in patients with polycystic ovary syndrome, *Fertil Steril* 67:463, 1997.

181. **De Leo V, Fulghesu AM, la Marca A, Morgante G, Pasqui L, Talluri B, Torricelli M, Caruso A**, Hormonal and clinical effects of GnRH agonist alone, or in combination with a combined oral contraceptive or flutamide in women with severe hirsutism, *Gynecol Endocrinol* 14:411, 2000.
182. **Mitwally MF, Casper RF**, Use of an aromatase inhibitor for induction of ovulation in patients with an inadequate response to clomiphene citrate, *Fertil Steril* 75:305, 2001.
183. ACOG Committee Opinion No. 738: Aromatase Inhibitors in Gynecologic Practice, *Obstet Gynecol* 131:e194, 2018.
184. **Franik S, Eltrop SM, Kremer JA, Kiesel L, Farquhar C**, Aromatase inhibitors (letrozole) for subfertile women with polycystic ovary syndrome, *Cochrane Database Syst Rev* (5):CD010287, 2018.
185. **Buzdar A, Howell A**, Advances in aromatase inhibition: clinical efficacy and tolerability in the treatment of breast cancer, *Clin Cancer Res* 7:2620, 2001.
186. **Winer EP, Hudis C, Burstein HJ, Chlebowski RT, Ingle JN, Edge SB, Mamounas EP, Gralow J, Goldstein LJ, Pritchard KI, Braun S, Cobleigh MA, Langer AS, Perotti J, Powles TJ, Whelan TJ, Browman GP**, American Society of Clinical Oncology technology assessment on the use of aromatase inhibitors as adjuvant therapy for women with hormone receptor-positive breast cancer: status report 2002, *J Clin Oncol* 20:3317, 2002.
187. **Naftolin F**, Brain aromatization of androgens, *J Reprod Med* 39:257, 1994.
188. **Naftolin F, MacLusky NJ, Leranath CZ, Sakamoto HS, Garcia-Segura LM**, The cellular effects of estrogens on neuroendocrine tissues, *J Steroid Biochem* 30:195, 1988.
189. **Kamat A, Hinshelwood MM, Murry BA, Mendelson CR**, Mechanisms in tissue-specific regulation of estrogen biosynthesis in humans, *Trends Endocrinol Metab* 13:122, 2002.
190. **Amer SA, Smith J, Mahran A, Fox P, Fakis A**, Double-blind randomized controlled trial of letrozole versus clomiphene citrate in subfertile women with polycystic ovarian syndrome, *Hum Reprod* 32:1631, 2017.
191. **Vendola KA, Zhou J, Adesanya OO, Weil SJ, Bondy CA**, Androgens stimulate early stages of follicular growth in the primate ovary, *J Clin Invest* 101:2622, 1998.
192. **Weil S, Vendola K, Zhou J, Bondy CA**, Androgen and follicle-stimulating hormone interactions in primate ovarian follicle development, *J Clin Endocrinol Metab* 84:2951, 1999.
193. **Vendola K, Zhou J, Wang J, Famuyiwa OA, Bievre M, Bondy CA**, Androgens promote oocyte insulin-like growth factor I expression and initiation of follicle development in the primate ovary, *Biol Reprod* 61:353, 1999.
194. **Giudice LC**, Insulin-like growth factors and ovarian follicular development, *Endocr Rev* 13:641, 1992.
195. **Adashi EY**, Intraovarian regulation: the proposed role of insulin-like growth factors, *Ann N Y Acad Sci* 687:10, 1993.
196. **Gadalla MA, Huang S, Wang R, Norman RJ, Abdullah SA, El Saman AM, Ismail AM, van Wely M, Mol BWJ**, Effect of clomiphene citrate on endometrial thickness, ovulation, pregnancy and live birth in anovulatory women: systematic review and meta-analysis, *Ultrasound Obstet Gynecol* 51:64, 2018.
197. **Mehdinejadi S, Amidi F, Mehdizadeh M, Barati M, Safdarian L, Aflatoonian R, Alyasin A, Aghahosseini M, Pazhohan A, Hayat P, Mohammadzadeh Kazorgah F, Sobhani A**, The effects of letrozole and clomiphene citrate on ligands expression of Wnt3, Wnt7a, and Wnt8b in proliferative endometrium of women with Polycystic ovarian syndrome, *Gynecol Endocrinol* 34:775, 2018.
198. **Mehdinejadi S, Amidi F, Mehdizadeh M, Barati M, Pazhohan A, Alyasin A, Mehdinejadi K, Sobhani A**, Effects of letrozole and clomiphene citrate on Wnt signaling pathway in endometrium of polycystic ovarian syndrome and healthy women, *Biol Reprod*, 100(3):641–648, 2019. doi: 10.1093/biolre/iy187.
199. **Miller PB, Parnell BA, Bushnell G, Tallman N, Forstein DA, Higdon HL III, Kitawaki J, Lessey BA**, Endometrial receptivity defects during IVF cycles with and without letrozole, *Hum Reprod* 27:881, 2012.
200. **Ganesh A, Chauhan N, Das S, Chakravarty B, Chaudhury K**, Endometrial receptivity markers in infertile women stimulated with letrozole compared with clomiphene citrate and natural cycles, *Syst Biol Reprod Med* 60:105, 2014.
201. **Ganesh A, Chattopadhyay R, Narendra Babu K, Chakravarty B, Chaudhury K**, Analysis of spindle characteristics and embryo quality in mice stimulated with letrozole using Polscope imaging, *Fertil Steril*

93:1477, 2010.

202. **Diamond MP, Legro RS, Coutifaris C, Alvero R, Robinson RD, Casson P, Christman GM, Ager J, Huang H, Hansen KR, Baker V, Usadi R, Seungdamrong A, Bates GW, Rosen RM, Haisenleder D, Krawetz SA, Barnhart K, Trussell JC, Ohl D, Jin Y, Santoro N, Eisenberg E, Zhang H; NICHD Reproductive Medicine Network,** Letrozole, gonadotropin, or clomiphene for unexplained infertility, *N Engl J Med* 373:1230, 2015.
203. **Tredway D, Schertz JC, Bock D, Hemsey G, Diamond MP,** Anastrozole single-dose protocol in women with oligo- or anovulatory infertility: results of a randomized phase II dose-response study, *Fertil Steril* 95:1725.e1, 2011.
204. **Ghomian N, Khosravi A, Mousavifar N,** A randomized clinical trial on comparing the cycle characteristics of two different initiation days of letrozole treatment in clomiphene citrate resistant PCOS patients in IUI cycles, *Int J Fertil Steril* 9:17, 2015.
205. **Badawy A, Mosbah A, Tharwat A, Eid M,** Extended letrozole therapy for ovulation induction in clomiphene-resistant women with polycystic ovary syndrome: a novel protocol, *Fertil Steril* 92:236, 2009.
206. **Dehbashi S, Dehbashi S, Kazerooni T, Robati M, Alborzi S, Parsanezhad ME, Shadman A,** Comparison of the effects of letrozole and clomiphene citrate on ovulation and pregnancy rate in patients with polycystic ovary syndrome, *Iran J Med Sci* 34:23, 2009.
207. **Warraich G, Vause TD,** First reported case of sextuplets conceived via letrozole for ovulation induction, *Fertil Steril* 103:535, 2015.
208. **Tulandi T, Martin J, Al-Fadhli R, Kabli N, Forman R, Hitkari J, Librach C, Greenblatt E, Casper RF,** Congenital malformations among 911 newborns conceived after infertility treatment with letrozole or clomiphene citrate, *Fertil Steril* 85:1761, 2006.
209. **Forman R, Gill S, Moretti M, Tulandi T, Koren G, Casper R,** Fetal safety of letrozole and clomiphene citrate for ovulation induction, *J Obstet Gynaecol Can* 29:668, 2007.
210. **Stein IF, Leventhal ML,** Amenorrhea associated with bilateral polycystic ovaries, *Am J Obstet Gynecol* 29:247.e1, 1935.
211. **Donesky BW, Adashi EY,** Surgically induced ovulation in the polycystic ovary syndrome: wedge resection revisited in the age of laparoscopy, *Fertil Steril* 63:439, 1995.
212. **Daniell JF, Miller W,** Polycystic ovaries treated by laparoscopic laser vaporization, *Fertil Steril* 51:232, 1989.
213. **Gjonness H,** Polycystic ovarian syndrome treated by ovarian electrocautery through the laparoscope, *Fertil Steril* 41:20, 1984.
214. **Zahiri Sorouri Z, Sharami SH, Tahersima Z, Salamat F,** Comparison between unilateral and bilateral ovarian drilling in clomiphene citrate resistance polycystic ovary syndrome patients: a randomized clinical trial of efficacy, *Int J Fertil Steril* 9:9, 2015.
215. **El-Sayed MLM, Ahmed MA, Mansour MAA, Mansour SAA,** Unilateral versus bilateral laparoscopic ovarian drilling using thermal dose adjusted according to ovarian volume in CC-resistant PCOS, a randomized study, *J Obstet Gynaecol India* 67:356, 2017.
216. **Farquhar C, Brown J, Marjoribanks J,** Laparoscopic drilling by diathermy or laser for ovulation induction in anovulatory polycystic ovary syndrome, *Cochrane Database Syst Rev* (6):CD001122, 2012.
217. **Seow KM, Juan CC, Hwang JL, Ho LT,** Laparoscopic surgery in polycystic ovary syndrome: reproductive and metabolic effects, *Semin Reprod Med* 26:101, 2008.
218. **Greenblatt E, Casper RF,** Endocrine changes after laparoscopic ovarian cautery in polycystic ovarian syndrome, *Am J Obstet Gynecol* 156:279, 1987.
219. **Armar NA, McGarrigle HH, Honour J, Holownia P, Jacobs HS, Lachelin GC,** Laparoscopic ovarian diathermy in the management of anovulatory infertility in women with polycystic ovaries: endocrine changes and clinical outcome, *Fertil Steril* 53:45, 1990.
220. **Lemieux S, Lewis GF, Ben-Chetrit A, Steiner G, Greenblatt EM,** Correction of hyperandrogenemia by laparoscopic ovarian cautery in women with polycystic ovarian syndrome is not accompanied by improved insulin sensitivity or lipid-lipoprotein levels, *J Clin Endocrinol Metab* 84:4278, 1999.
221. **Kovacs G, Buckler H, Bangah M, Outch K, Burger H, Healy D, Baker G, Phillips S,** Treatment of

- anovulation due to polycystic ovarian syndrome by laparoscopic ovarian electrocautery, *Br J Obstet Gynaecol* 98:30, 1991.
222. **Lockwood GM, Muttukrishna S, Groome NP, Matthews DR, Ledger WL**, Mid-follicular phase pulses of inhibin B are absent in polycystic ovarian syndrome and are initiated by successful laparoscopic ovarian diathermy: a possible mechanism regulating emergence of the dominant follicle, *J Clin Endocrinol Metab* 83:1730, 1998.
  223. **Naether OG, Fischer R**, Adhesion formation after laparoscopic electrocoagulation of the ovarian surface in polycystic ovary patients, *Fertil Steril* 60:95, 1993.
  224. **Naether OG, Fischer R, Weise HC, Geiger-Kotzler L, Delfs T, Rudolf K**, Laparoscopic electrocoagulation of the ovarian surface in infertile patients with polycystic ovarian disease, *Fertil Steril* 60:88, 1993.
  225. **Gurgan T, Kisinisci H, Yarali H, Develioglu O, Zeyneloglu H, Aksu T**, Evaluation of adhesion formation after laparoscopic treatment of polycystic ovarian disease, *Fertil Steril* 56:1176, 1991.
  226. **Greenblatt EM, Casper RF**, Adhesion formation after laparoscopic ovarian cautery for polycystic ovarian syndrome: lack of correlation with pregnancy rate, *Fertil Steril* 60:766, 1993.
  227. **Gurgan T, Urman B, Aksu T, Yarali H, Develioglu O, Kisinisci HA**, The effect of short-interval laparoscopic lysis of adhesions on pregnancy rates following Nd-YAG laser photocoagulation of polycystic ovaries, *Obstet Gynecol* 80:45, 1992.
  228. **Farquhar C, Vandekerckhove P, Lilford R**, Laparoscopic “drilling” by diathermy or laser for ovulation induction in anovulatory polycystic ovary syndrome, *Cochrane Database Syst Rev* (4):CD001122, 2001.
  229. **Dabirashrafi H**, Complications of laparoscopic ovarian cauterization, *Fertil Steril* 52:878, 1989.
  230. **Giampaolino P, Morra I, De Rosa N, Cagnacci A, Pellicano M, Di Carlo C, Nappi C, Bifulco G**, Impact of transvaginal hydrolaparoscopy ovarian drilling on ovarian stromal blood flow and ovarian volume in clomiphene citrate-resistant PCOS patients: a case-control study, *Gynecol Endocrinol* 33:690, 2017.
  231. **Melica F, Chiodi S, Cristoforoni PM, Ravera GB**, Reductive surgery and ovarian function in the human—can reductive ovarian surgery in reproductive age negatively influence fertility and age at onset of menopause? *Int J Fertil Menopausal Stud* 40:79, 1995.
  232. **Armar NA, Lachelin GC**, Laparoscopic ovarian diathermy: an effective treatment for anti-oestrogen resistant anovulatory infertility in women with the polycystic ovary syndrome, *Br J Obstet Gynaecol* 100:161, 1993.
  233. **Farhi J, Soule S, Jacobs HS**, Effect of laparoscopic ovarian electrocautery on ovarian response and outcome of treatment with gonadotropins in clomiphene citrate-resistant patients with polycystic ovary syndrome, *Fertil Steril* 64:930, 1995.
  234. **Balen AH, Braat DD, West C, Patel A, Jacobs HS**, Cumulative conception and live birth rates after the treatment of anovulatory infertility: safety and efficacy of ovulation induction in 200 patients, *Hum Reprod* 9:1563, 1994.
  235. **Farquhar CM, Williamson K, Gudex G, Johnson NP, Garland J, Sadler L**, A randomized controlled trial of laparoscopic ovarian diathermy versus gonadotropin therapy for women with clomiphene citrate-resistant polycystic ovary syndrome, *Fertil Steril* 78:404, 2002.
  236. **Gjonnaess H**, Ovarian electrocautery in the treatment of women with polycystic ovary syndrome (PCOS). Factors affecting the results, *Acta Obstet Gynecol Scand* 73:407, 1994.
  237. **Gjonnaess H**, The course and outcome of pregnancy after ovarian electrocautery in women with polycystic ovarian syndrome: the influence of body-weight, *Br J Obstet Gynaecol* 96:714, 1989.
  238. **Gjonnaess H**, A simple treatment for polycystic ovarian syndrome, *World Health Forum* 11:214, 1990.
  239. **Lunenfeld B**, Historical perspectives in gonadotrophin therapy, *Hum Reprod Update* 10:453, 2004.
  240. **Casper RF**, Are recombinant gonadotrophins safer, purer and more effective than urinary gonadotrophins? *Reprod Biomed Online* 11:539, 2005.
  241. **Practice Committee of American Society for Reproductive Medicine, Birmingham, Alabama**, Gonadotropin preparations: past, present, and future perspectives, *Fertil Steril* 90:S13, 2008.
  242. **Stokman PG, de Leeuw R, van den Wijngaard HA, Kloosterboer HJ, Vemer HM, Sanders AL**, Human chorionic gonadotropin in commercial human menopausal gonadotropin preparations, *Fertil Steril*

60:175, 1993.

243. **Rosenberg E, Coleman J, Damani M, Garcia CR**, Clinical effect of postmenopausal gonadotropin, *J Clin Endocrinol Metab* 23:181–190, 1963.
244. **Lunenfeld B**, Treatment of anovulation by human gonadotropins, *J Int Fed Gynaecol Obstet* 1:153–167, 1963. doi: <https://doi.org/10.1002/j.1879-3479.1963.tb00335.x>.
245. **van de Weijer BH, Mulders JW, Bos ES, Verhaert PD, van den Hooven HW**, Compositional analyses of a human menopausal gonadotrophin preparation extracted from urine (menotropin). Identification of some of its major impurities, *Reprod Biomed Online* 7:547, 2003.
246. **Gocial B, Keye WR, Fein SH, Nardi RV**, Subcutaneously administered Repronex in female patients undergoing in vitro fertilization is as effective and well tolerated as intramuscular menotropin treatment. Repronex SC, IVF Study Group, *Fertil Steril* 74:73, 2000.
247. **Giudice E, Crisci C, Eshkol A, Papoian R**, Composition of commercial gonadotrophin preparations extracted from human post-menopausal urine: characterization of non-gonadotrophin proteins, *Hum Reprod* 9:2291, 1994.
248. **Filicori M, Cognigni GE, Pocognoli P, Tabarelli C, Ferlini F, Perri T, Parmegiani L**, Comparison of controlled ovarian stimulation with human menopausal gonadotropin or recombinant follicle-stimulating hormone, *Fertil Steril* 80:390, 2003.
249. **Olijve W, de Boer W, Mulders JW, van Wezenbeek PM**, Molecular biology and biochemistry of human recombinant follicle stimulating hormone (Puregon), *Mol Hum Reprod* 2:371, 1996.
250. **Steelman SL, Pohley FM**, Assay of the follicle stimulating hormone based on the augmentation with human chorionic gonadotropin, *Endocrinology* 53:604, 1953.
251. **Fausser BC, Mannaerts BM, Devroey P, Leader A, Boime I, Baird DT**, Advances in recombinant DNA technology: corifollitropin alfa, a hybrid molecule with sustained follicle-stimulating activity and reduced injection frequency, *Hum Reprod Update* 15:309, 2009.
252. **Loutradis D, Drakakis P, Vlismas A, Antsaklis A**, Corifollitropin alfa, a long-acting follicle-stimulating hormone agonist for the treatment of infertility, *Curr Opin Investig Drugs* 10:372, 2009.
253. **Olsson H, Sandstrom R, Grundemar L**, Different pharmacokinetic and pharmacodynamic properties of recombinant follicle-stimulating hormone (rFSH) derived from a human cell line compared with rFSH from a non-human cell line, *J Clin Pharmacol* 54:1299, 2014.
254. **le Cotonnec JY, Loumaye E, Porchet HC, Beltrami V, Munafò A**, Pharmacokinetic and pharmacodynamic interactions between recombinant human luteinizing hormone and recombinant human follicle-stimulating hormone, *Fertil Steril* 69:201, 1998.
255. **le Cotonnec JY, Porchet HC, Beltrami V, Munafò A**, Clinical pharmacology of recombinant human luteinizing hormone: Part II. Bioavailability of recombinant human luteinizing hormone assessed with an immunoassay and an in vitro bioassay, *Fertil Steril* 69:195, 1998.
256. **Porchet HC, Le Cotonnec JY, Neuteboom B, Canali S, Zanolò G**, Pharmacokinetics of recombinant human luteinizing hormone after intravenous, intramuscular, and subcutaneous administration in monkeys and comparison with intravenous administration of pituitary human luteinizing hormone, *J Clin Endocrinol Metab* 80:667, 1995.
257. Recombinant human luteinizing hormone (LH) to support recombinant human follicle-stimulating hormone (FSH)-induced follicular development in LH- and FSH-deficient anovulatory women: a dose-finding study. The European Recombinant Human LH Study Group, *J Clin Endocrinol Metab* 83:1507, 1998.
258. **Kolibianakis EM, Kalogeropoulou L, Griesinger G, Papanikolaou EG, Papadimas J, Bontis J, Tarlatzis BC**, Among patients treated with FSH and GnRH analogues for in vitro fertilization, is the addition of recombinant LH associated with the probability of live birth? A systematic review and meta-analysis, *Hum Reprod Update* 13:445, 2007.
259. **Mochtar MH, Van der Veen F, Ziech M, van Wely M**, Recombinant Luteinizing Hormone (rLH) for controlled ovarian hyperstimulation in assisted reproductive cycles, *Cochrane Database Syst Rev* (2):CD005070, 2007.
260. **Ludwig M, Doody KJ, Doody KM**, Use of recombinant human chorionic gonadotropin in ovulation induction,

Fertil Steril 79:1051, 2003.

261. **Youssef MA, Abou-Setta AM, Lam WS**, Recombinant versus urinary human chorionic gonadotrophin for final oocyte maturation triggering in IVF and ICSI cycles, *Cochrane Database Syst Rev* (4):CD003719, 2016.
262. **Butler SA**, hCG—mass units, molar conversions, and the standardization of biologic units, *Fertil Steril* 80:1533; author reply 1533, 2003.
263. **McDonough PG**, hCG—mass units, molar conversions, and the standardization of biologic units, *Fertil Steril* 80:1534, 2003.
264. **Chang P, Kenley S, Burns T, Denton G, Currie K, DeVane G, O’Dea L**, Recombinant human chorionic gonadotropin (rhCG) in assisted reproductive technology: results of a clinical trial comparing two doses of rhCG (Ovidrel) to urinary hCG (Profasi) for induction of final follicular maturation in in vitro fertilization-embryo transfer, *Fertil Steril* 76:67, 2001.
265. **International Recombinant Human Chorionic Gonadotropin Study Group**, Induction of ovulation in World Health Organization group II anovulatory women undergoing follicular stimulation with recombinant human follicle-stimulating hormone: a comparison of recombinant human chorionic gonadotropin (rhCG) and urinary hCG, *Fertil Steril* 75:1111, 2001.
266. **Fausser BC**, Follicular development and oocyte maturation in hypogonadotrophic women employing recombinant follicle-stimulating hormone: the role of oestradiol, *Hum Reprod Update* 3:101, 1997.
267. **Filicori M**, The role of luteinizing hormone in folliculogenesis and ovulation induction, *Fertil Steril* 71:405, 1999.
268. **Levy DP, Navarro JM, Schattman GL, Davis OK, Rosenwaks Z**, The role of LH in ovarian stimulation: exogenous LH: let’s design the future, *Hum Reprod* 15:2258, 2000.
269. **Danforth DR**, Endocrine and paracrine control of oocyte development, *Am J Obstet Gynecol* 172:747, 1995.
270. **Couzinet B, Lestrat N, Brailly S, Forest M, Schaison G**, Stimulation of ovarian follicular maturation with pure follicle-stimulating hormone in women with gonadotropin deficiency, *J Clin Endocrinol Metab* 66:552, 1988.
271. **Strauss JF III, Steinkampf MP**, Pituitary-ovarian interactions during follicular maturation and ovulation, *Am J Obstet Gynecol* 172:726, 1995.
272. **Schoot DC, Harlin J, Shoham Z, Mannaerts BM, Lahlou N, Bouchard P, Bennink HJ, Fausser BC**, Recombinant human follicle-stimulating hormone and ovarian response in gonadotrophin-deficient women, *Hum Reprod* 9:1237, 1994.
273. **Shoham Z, Balen A, Patel A, Jacobs HS**, Results of ovulation induction using human menopausal gonadotropin or purified follicle-stimulating hormone in hypogonadotropic hypogonadism patients, *Fertil Steril* 56:1048, 1991.
274. **Carone D, Caropreso C, Vitti A, Chiappetta R**, Efficacy of different gonadotropin combinations to support ovulation induction in WHO type I anovulation infertility: clinical evidences of human recombinant FSH/human recombinant LH in a 2:1 ratio and highly purified human menopausal gonadotropin stimulation protocols, *J Endocrinol Invest* 35:996, 2012.
275. **Keenan JA, Moghissi KS**, Luteal phase support with hCG does not improve fecundity rate in human menopausal gonadotropin-stimulated cycles, *Obstet Gynecol* 79:983, 1992.
276. **Messinis IE, Bergh T, Wide L**, The importance of human chorionic gonadotropin support of the corpus luteum during human gonadotropin therapy in women with anovulatory infertility, *Fertil Steril* 50:31, 1988.
277. **Hamilton CJ, Jaroudi KA, Sieck UV**, The value of luteal support with progesterone in gonadotropin-induced cycles, *Fertil Steril* 60:786, 1993.
278. **Blumenfeld Z, Nahhas F**, Luteal dysfunction in ovulation induction: the role of repetitive human chorionic gonadotropin supplementation during the luteal phase, *Fertil Steril* 50:403, 1988.
279. **Noci I, Biagiotti R, Maggi M, Ricci F, Cinotti A, Scarselli G**, Low day 3 luteinizing hormone values are predictive of reduced response to ovarian stimulation, *Hum Reprod* 13:531, 1998.
280. **Farine D, Dor J, Lupovici N, Lunenfeld B, Mashiach S**, Conception rate after gonadotropin therapy in hyperprolactinemia and normoprolactinemia, *Obstet Gynecol* 65:658, 1985.
281. **Weiss NS, Nahuis M, Bayram N, Mol BW, Van der Veen F, van Wely M**, Gonadotrophins for ovulation induction in women with polycystic ovarian syndrome, *Cochrane Database Syst Rev* (1):CD010290, 2015.

282. **Dodson WC, Hughes CL Jr, Yancy SE, Haney AF**, Clinical characteristics of ovulation induction with human menopausal gonadotropins with and without leuprolide acetate in polycystic ovary syndrome, *Fertil Steril* 52:915, 1989.
283. **Whelan JG III, Vlahos NF**, The ovarian hyperstimulation syndrome, *Fertil Steril* 73:883, 2000.
284. **Green KA, Zolton JR, Schermerhorn SM, Lewis TD, Healy MW, Terry N, DeCherney AH, Hill MJ**, Progesterone luteal support after ovulation induction and intrauterine insemination: an updated systematic review and meta-analysis, *Fertil Steril* 107:924.e5, 2017.
285. **Thompson CR, Hansen LM**, Pergonal (menotropins): a summary of clinical experience in the induction of ovulation and pregnancy, *Fertil Steril* 21:844, 1970.
286. **Olive DL**, The role of gonadotropins in ovulation induction, *Am J Obstet Gynecol* 172:759, 1995.
287. **Chong AP, Rafael RW, Forte CC**, Influence of weight in the induction of ovulation with human menopausal gonadotropin and human chorionic gonadotropin, *Fertil Steril* 46:599, 1986.
288. **Van Der Meer M, Hompes PG, De Boer JA, Schats R, Schoemaker J**, Cohort size rather than follicle-stimulating hormone threshold level determines ovarian sensitivity in polycystic ovary syndrome, *J Clin Endocrinol Metab* 83:423, 1998.
289. **Homburg R, Levy T, Ben-Rafael Z**, A comparative prospective study of conventional regimen with chronic low-dose administration of follicle-stimulating hormone for anovulation associated with polycystic ovary syndrome, *Fertil Steril* 63:729, 1995.
290. **White DM, Polson DW, Kiddy D, Sagle P, Watson H, Gilling-Smith C, Hamilton-Fairley D, Franks S**, Induction of ovulation with low-dose gonadotropins in polycystic ovary syndrome: an analysis of 109 pregnancies in 225 women, *J Clin Endocrinol Metab* 81:3821, 1996.
291. **Hedon B, Hugues JN, Emperaire JC, Chabaud JJ, Barbereau D, Boujenah A, Howles CM, Truong F**, A comparative prospective study of a chronic low dose versus a conventional ovulation stimulation regimen using recombinant human follicle stimulating hormone in anovulatory infertile women, *Hum Reprod* 13:2688, 1998.
292. **Homburg R, Howles CM**, Low-dose FSH therapy for anovulatory infertility associated with polycystic ovary syndrome: rationale, results, reflections and refinements, *Hum Reprod Update* 5:493, 1999.
293. **Calaf Alsina J, Ruiz Balda JA, Romeu Sarrío A, Caballero Fernandez V, Cano Trigo I, Gomez Parga JL, Gonzalez Batres C, Rodriguez Escudero FJ**, Ovulation induction with a starting dose of 50 IU of recombinant follicle stimulating hormone in WHO group II anovulatory women: the IO-50 study, a prospective, observational, multicentre, open trial, *BJOG* 110:1072, 2003.
294. **Dale PO, Tanbo T, Haug E, Abyholm T**, The impact of insulin resistance on the outcome of ovulation induction with low-dose follicle stimulating hormone in women with polycystic ovary syndrome, *Hum Reprod* 13:567, 1998.
295. **De Leo V, la Marca A, Ditto A, Morgante G, Cianci A**, Effects of metformin on gonadotropin-induced ovulation in women with polycystic ovary syndrome, *Fertil Steril* 72:282, 1999.
296. **Filicori M, Cognigni GE, Tabarelli C, Pocognoli P, Taraborrelli S, Spettoli D, Ciampaglia W**, Stimulation and growth of antral ovarian follicles by selective LH activity administration in women, *J Clin Endocrinol Metab* 87:1156, 2002.
297. **Filicori M, Cognigni GE, Taraborrelli S, Spettoli D, Ciampaglia W, de Fatis CT, Pocognoli P**, Luteinizing hormone activity supplementation enhances follicle-stimulating hormone efficacy and improves ovulation induction outcome, *J Clin Endocrinol Metab* 84:2659, 1999.
298. **Zeleznik AJ, Hillier SG**, The role of gonadotropins in the selection of the preovulatory follicle, *Clin Obstet Gynecol* 27:927, 1984.
299. **Zeleznik AJ, Midgley AR Jr, Reichert LE Jr**, Granulosa cell maturation in the rat: increased binding of human chorionic gonadotropin following treatment with follicle-stimulating hormone in vivo, *Endocrinology* 95:818, 1974.
300. **Shima K, Kitayama S, Nakano R**, Gonadotropin binding sites in human ovarian follicles and corpora lutea during the menstrual cycle, *Obstet Gynecol* 69:800, 1987.
301. **Rani CS, Salhanick AR, Armstrong DT**, Follicle-stimulating hormone induction of luteinizing hormone

- receptor in cultured rat granulosa cells: an examination of the need for steroids in the induction process, *Endocrinology* 108:1379, 1981.
302. **Filicori M, Cognigni GE, Taraborrelli S, Spettoli D, Ciampaglia W, de Fatis CT**, Low-dose human chorionic gonadotropin therapy can improve sensitivity to exogenous follicle-stimulating hormone in patients with secondary amenorrhea, *Fertil Steril* 72:1118, 1999.
  303. **Hillier SG, Whitelaw PF, Smyth CD**, Follicular oestrogen synthesis: the 'two-cell, two-gonadotrophin' model revisited, *Mol Cell Endocrinol* 100:51, 1994.
  304. **Egbase PE, Al Sharhan M, Berlingieri P, Grudzinskas JG**, Serum oestradiol and progesterone concentrations during prolonged coasting in 15 women at risk of ovarian hyperstimulation syndrome following ovarian stimulation for assisted reproduction treatment, *Hum Reprod* 15:2082, 2000.
  305. **Sullivan MW, Stewart-Akers A, Krasnow JS, Berga SL, Zeleznik AJ**, Ovarian responses in women to recombinant follicle-stimulating hormone and luteinizing hormone (LH): a role for LH in the final stages of follicular maturation, *J Clin Endocrinol Metab* 84:228, 1999.
  306. **Loumaye E, Engrand P, Shoham Z, Hillier SG, Baird DT**, Clinical evidence for an LH 'ceiling' effect induced by administration of recombinant human LH during the late follicular phase of stimulated cycles in World Health Organization type I and type II anovulation, *Hum Reprod* 18:314, 2003.
  307. **Filicori M, Flamigni C, Cognigni GE, Falbo A, Arnone R, Capelli M, Pavani A, Mandini M, Calderoni P, Brondelli L**, Different gonadotropin and leuporelin ovulation induction regimens markedly affect follicular fluid hormone levels and folliculogenesis, *Fertil Steril* 65:387, 1996.
  308. **Filicori M, Cognigni GE, Pocognoli P, Tabarelli C, Spettoli D, Taraborrelli S, Ciampaglia W**, Modulation of folliculogenesis and steroidogenesis in women by graded menotrophin administration, *Hum Reprod* 17:2009, 2002.
  309. **Loumaye E, Engrand P, Shoham Z, Hillier SG, Baird DT**, Clinical evidence for an LH ceiling? *Hum Reprod* 18:2719, 2003.
  310. **Filicori M, Cognigni GE, Ciampaglia W**, What clinical evidence for an LH ceiling? *Hum Reprod* 18:1556, 2003.
  311. **March CM, Tredway DR, Mishell DR Jr**, Effect of clomiphene citrate upon amount and duration of human menopausal gonadotropin therapy, *Am J Obstet Gynecol* 125:699, 1976.
  312. **Ron-el R, Soffer Y, Langer R, Herman A, Weintraub Z, Caspi E**, Low multiple pregnancy rate in combined clomiphene citrate—human menopausal gonadotrophin treatment for ovulation induction or enhancement, *Hum Reprod* 4:495, 1989.
  313. **Lu PY, Chen AL, Atkinson EJ, Lee SH, Erickson LD, Ory SJ**, Minimal stimulation achieves pregnancy rates comparable to human menopausal gonadotropins in the treatment of infertility, *Fertil Steril* 65:583, 1996.
  314. **Ransom MX, Doughman NC, Garcia AJ**, Menotropins alone are superior to a clomiphene citrate and menotropin combination for superovulation induction among clomiphene citrate failures, *Fertil Steril* 65:1169, 1996.
  315. **Dodson WC, Hughes CL, Whitesides DB, Haney AF**, The effect of leuprolide acetate on ovulation induction with human menopausal gonadotropins in polycystic ovary syndrome, *J Clin Endocrinol Metab* 65:95, 1987.
  316. **Manzi DL, Dumez S, Scott LB, Nulsen JC**, Selective use of leuprolide acetate in women undergoing superovulation with intrauterine insemination results in significant improvement in pregnancy outcome, *Fertil Steril* 63:866, 1995.
  317. **Sagle M, Bishop K, Ridley N, Alexander FM, Michel M, Bonney RC, Beard RW, Franks S**, Recurrent early miscarriage and polycystic ovaries, *BMJ* 297:1027, 1988.
  318. **Regan L, Owen EJ, Jacobs HS**, Hypersecretion of luteinising hormone, infertility, and miscarriage, *Lancet* 336:1141, 1990.
  319. **Homburg R, Armar NA, Eshel A, Adams J, Jacobs HS**, Influence of serum luteinising hormone concentrations on ovulation, conception, and early pregnancy loss in polycystic ovary syndrome, *BMJ* 297:1024, 1988.
  320. **Tulppala M, Palosuo T, Ramsay T, Miettinen A, Salonen R, Ylikorkala O**, A prospective study of 63

couples with a history of recurrent spontaneous abortion: contributing factors and outcome of subsequent pregnancies, *Hum Reprod* 8:764, 1993.

321. **Fleming R, Coutts JR**, LHRH analogues for ovulation induction, with particular reference to polycystic ovary syndrome, *Baillieres Clin Obstet Gynaecol* 2:677, 1988.
322. **Bachus KE, Hughes CL Jr, Haney AF, Dodson WC**, The luteal phase in polycystic ovary syndrome during ovulation induction with human menopausal gonadotropin with and without leuprolide acetate, *Fertil Steril* 54:27, 1990.
323. **Gagliardi CL, Emmi AM, Weiss G, Schmidt CL**, Gonadotropin-releasing hormone agonist improves the efficiency of controlled ovarian hyperstimulation/intrauterine insemination, *Fertil Steril* 55:939, 1991.
324. **Homburg R, Eshel A, Kilborn J, Adams J, Jacobs HS**, Combined luteinizing hormone releasing hormone analogue and exogenous gonadotrophins for the treatment of infertility associated with polycystic ovaries, *Hum Reprod* 5:32, 1990.
325. **Hughes E, Collins J, Vandekerckhove P**, Gonadotrophin-releasing hormone analogue as an adjunct to gonadotropin therapy for clomiphene-resistant polycystic ovarian syndrome, *Cochrane Database Syst Rev* (2):CD000097, 2000.
326. **Dodson WC, Walmer DK, Hughes CL Jr, Yancy SE, Haney AF**, Adjunctive leuprolide therapy does not improve cycle fecundity in controlled ovarian hyperstimulation and intrauterine insemination of subfertile women, *Obstet Gynecol* 78:187, 1991.
327. **Muechler EK, Kohler D, Huang KE**, Monitoring of ovulation induction with HMG-HCG therapy by plasma estrogen and progesterone, *Int J Fertil* 26:273, 1981.
328. **Reuter KL, Cohen S, Furey L, Baker S**, Sonographic appearance of the endometrium and ovaries during cycles stimulated with human menopausal gonadotropin, *J Reprod Med* 41:509, 1996.
329. **Haning RV Jr, Levin RM, Behrman HR, Kase NG, Speroff L**, Plasma estradiol window and urinary estriol glucuronide determinations for monitoring menotropin induction of ovulation, *Obstet Gynecol* 54:442, 1979.
330. **Diamond MP, Wentz AC**, Ovulation induction with human menopausal gonadotropins, *Obstet Gynecol Surv* 41:480, 1986.
331. **Navot D, Margalioth EJ, Laufer N, Brzezinski A, Birkenfeld A, Schenker JG**, Periovalutary 17 beta-estradiol pattern in conceptional and nonconceptional cycles during menotropin treatment of anovulatory infertility, *Fertil Steril* 47:234, 1987.
332. **Silverberg KM, Olive DL, Burns WN, Johnson JV, Groff TR, Schenken RS**, Follicular size at the time of human chorionic gonadotropin administration predicts ovulation outcome in human menopausal gonadotropin-stimulated cycles, *Fertil Steril* 56:296, 1991.
333. **Navot D, Relou A, Birkenfeld A, Rabinowitz R, Brzezinski A, Margalioth EJ**, Risk factors and prognostic variables in the ovarian hyperstimulation syndrome, *Am J Obstet Gynecol* 159:210, 1988.
334. **Diamond MP, DeCherney AH, Baretto P, Lunefeld B**, Multiple consecutive cycles of ovulation induction with human menopausal gonadotropins, *Gynecol Endocrinol* 3:237, 1989.
335. **Silverberg KM, Klein NA, Burns WN, Schenken RS, Olive DL**, Consecutive versus alternating cycles of ovarian stimulation using human menopausal gonadotrophin, *Hum Reprod* 7:940, 1992.
336. **Akin JW, Shepard MK**, The effects of baseline ovarian cysts on cycle fecundity in controlled ovarian hyperstimulation, *Fertil Steril* 59:453, 1993.
337. **Shoham Z, Di Carlo C, Patel A, Conway GS, Jacobs HS**, Is it possible to run a successful ovulation induction program based solely on ultrasound monitoring? The importance of endometrial measurements, *Fertil Steril* 56:836, 1991.
338. **Weiss NS, van Vliet MN, Limpens J, Hompes PGA, Lambalk CB, Mochtar MH, van der Veen F, Mol BWJ, van Wely M**, Endometrial thickness in women undergoing IUI with ovarian stimulation. How thick is too thin? A systematic review and meta-analysis, *Hum Reprod* 32:1009, 2017.
339. **Isaacs JD Jr, Wells CS, Williams DB, Odem RR, Gast MJ, Strickler RC**, Endometrial thickness is a valid monitoring parameter in cycles of ovulation induction with menotropins alone, *Fertil Steril* 65:262, 1996.
340. **Dickey RP, Olar TT, Taylor SN, Curole DN, Matulich EM**, Relationship of endometrial thickness and



pattern to fecundity in ovulation induction cycles: effect of clomiphene citrate alone and with human menopausal gonadotropin, *Fertil Steril* 59:756, 1993.

341. **Schwartz M, Jewelewicz R, Dyrenfurth I, Tropper P, Vande Wiele RL**, The use of human menopausal and chorionic gonadotropins for induction of ovulation, Sixteen years' experience at the Sloane Hospital for Women, *Am J Obstet Gynecol* 138:801, 1980.
342. **Ho YB, Pride SM**, Induction of ovulation with exogenous gonadotropins in anovulatory infertile women, *Semin Reprod Med* 8:186–197, 1990.
343. **Fluker MR, Urman B, Mackinnon M, Barrow SR, Pride SM, Yuen BH**, Exogenous gonadotropin therapy in World Health Organization groups I and II ovulatory disorders, *Obstet Gynecol* 83:189, 1994.
344. **Dor J, Itzkowicz DJ, Mashiach S, Lunenfeld B, Serr DM**, Cumulative conception rates following gonadotropin therapy, *Am J Obstet Gynecol* 136:102, 1980.
345. **Hall JG**, Twinning, *Lancet* 362:735, 2003.
346. **Gleicher N, Oleske DM, Tur-Kaspa I, Vidali A, Karande V**, Reducing the risk of high-order multiple pregnancy after ovarian stimulation with gonadotropins, *N Engl J Med* 343:2, 2000.
347. **Peeraer K, Debrock S, De Loecker P, Tomassetti C, Laenen A, Welkenhuysen M, Meeuwis L, Pelckmans S, Mol BW, Spiessens C, De Neubourg D, D'Hooghe TM**, Low-dose human menopausal gonadotrophin versus clomiphene citrate in subfertile couples treated with intrauterine insemination: a randomized controlled trial, *Hum Reprod* 30:1079, 2015.
348. **Danhof NA, van Wely M, Repping S, Koks C, Verhoeve HR, de Bruin JP, Verberg MFG, van Hooff MHA, Cohlen BJ, van Heteren CF, Fleischer K, Gianotten J, van Disseldorp J, Visser J, Broekmans FJM, Mol BWJ, van der Veen F, Mochtar MH; SUPER study group**, Follicle stimulating hormone versus clomiphene citrate in intrauterine insemination for unexplained subfertility: a randomized controlled trial, *Hum Reprod* 33:1866, 2018.
349. **Derom C, Vlietinck R, Derom R, Van den Berghe H, Thiery M**, Increased monozygotic twinning rate after ovulation induction, *Lancet* 1:1236, 1987.
350. **Bohrer M, Kemmann E**, Risk factors for spontaneous abortion in menotropin-treated women, *Fertil Steril* 48:571, 1987.
351. **Shoham Z, Zosmer A, Insler V**, Early miscarriage and fetal malformations after induction of ovulation (by clomiphene citrate and/or human menotropins), in vitro fertilization, and gamete intrafallopian transfer, *Fertil Steril* 55:1, 1991.
352. **Martin JA, Hamilton BE, Osterman MJK, Driscoll AK, Drake P**, Births: final data for 2016, *Natl Vital Stat Rep* 67:1, 2018.
353. **Centers for Disease Control and Prevention (CDC)**, Contribution of assisted reproductive technology and ovulation-inducing drugs to triplet and higher-order multiple births—United States, 1980-1997, *MMWR Morb Mortal Wkly Rep* 49:535, 2000.
354. **Smith LK, Manktelow BN, Draper ES, Boyle EM, Johnson SJ, Field DJ**, Trends in the incidence and mortality of multiple births by socioeconomic deprivation and maternal age in England: population-based cohort study, *BMJ Open* 4:e004514, 2014.
355. **Santana DS, Cecatti JG, Haddad SM, Parpinelli MA, Costa ML, Surita FG, Sousa MH; Brazilian Network for the Surveillance of Severe Maternal Morbidity Study Group**, Severe maternal morbidity and perinatal outcomes of multiple pregnancy in the Brazilian Network for the Surveillance of Severe Maternal Morbidity, *Int J Gynaecol Obstet* 139:230, 2017.
356. [1995 FIVNAT evaluation], *Contracept Fertil Sex* 24:694, 1996.
357. **Martin JA, MacDorman MF, Mathews TJ**, Triplet births: trends and outcomes, 1971-94, *Vital Health Stat* 21 21:1, 1997.
358. **Bromer JG, Ata B, Seli M, Lockwood CJ, Seli E**, Preterm deliveries that result from multiple pregnancies associated with assisted reproductive technologies in the USA: a cost analysis, *Curr Opin Obstet Gynecol* 23:168, 2011.
359. Multiple gestation pregnancy. The ESHRE Capri Workshop Group, *Hum Reprod* 15:1856, 2000.
360. **Bryan E**, The impact of multiple preterm births on the family, *BJOG* 110(Suppl 20):24, 2003.

361. **Practice Committee of American Society for Reproductive Medicine**, Multiple gestation associated with infertility therapy: an American Society for Reproductive Medicine Practice Committee opinion, *Fertil Steril* 97:825, 2012.
362. **Kulkarni AD, Jamieson DJ, Jones HW Jr, Kissin DM, Gallo MF, Macaluso M, Adashi EY**, Fertility treatments and multiple births in the United States, *N Engl J Med* 369:2218, 2013.
363. **Gleicher N, Vidail A, Karande V**, Risks of multiple pregnancy—the decision belongs to whom? *Fertil Steril* 76:423; author reply 424, 2001.
364. **Grobman WA, Milad MP, Stout J, Klock SC**, Patient perceptions of multiple gestations: an assessment of knowledge and risk aversion, *Am J Obstet Gynecol* 185:920, 2001.
365. **Dickey RP**, A year of inaction on high-order multiple pregnancies due to ovulation induction, *Fertil Steril* 79:14, 2003.
366. **Fritz MA, Ory SJ**, Practice guidelines cannot be justified in the absence of sufficient evidence: inaction is far more appropriate than indefensible action, *Fertil Steril* 79:22, 2003.
367. **Dickey RP, Taylor SN, Lu PY, Sartor BM, Rye PH, Pyrzak R**, Relationship of follicle numbers and estradiol levels to multiple implantation in 3,608 intrauterine insemination cycles, *Fertil Steril* 75:69, 2001.
368. **Tur R, Barri PN, Coroleu B, Buxaderas R, Martinez F, Balasch J**, Risk factors for high-order multiple implantation after ovarian stimulation with gonadotrophins: evidence from a large series of 1878 consecutive pregnancies in a single centre, *Hum Reprod* 16:2124, 2001.
369. **Ragni G, Maggioni P, Guermandi E, Testa A, Baroni E, Colombo M, Crosignani PG**, Efficacy of double intrauterine insemination in controlled ovarian hyperstimulation cycles, *Fertil Steril* 72:619, 1999.
370. **Dickey RP, Pyrzak R**, Prevention of high order multiple pregnancy, *Hum Reprod* 17:1411; author reply 1411, 2002.
371. **Haydardedeoglu B, Bagis T, Simsek E, Cok T, Hacivelioglu SO, Erkanli S**, The impact of rescue in vitro fertilization converted from high-response gonadotropin intrauterine insemination cycles in terms of implantation and pregnancy rates as compared with matched controls, *Fertil Steril* 92:137, 2009.
372. **Many A, Azem F, Lessing JB, Yovel I, Yavetz H, Amit A**, Pregnancy rate in IVF rescue in high responders to human menopausal gonadotropin, *J Assist Reprod Genet* 16:520, 1999.
373. **Balayla J, Granger L, St-Michel P, Villeneuve M, Fontaine JY, Desrosiers P, Dahdouh EM**, Rescue in vitro fertilization using a GnRH antagonist in hyper-responders from gonadotropin intrauterine insemination (IUI) cycles, *J Assist Reprod Genet* 30:773, 2013.
374. **De Geyter C, De Geyter M, Nieschlag E**, Low multiple pregnancy rates and reduced frequency of cancellation after ovulation induction with gonadotropins, if eventual supernumerary follicles are aspirated to prevent polyovulation, *J Assist Reprod Genet* 15:111, 1998.
375. **Albano C, Platteau P, Nogueira D, Cortvrindt R, Smitz J, Devroey P**, Avoidance of multiple pregnancies after ovulation induction by supernumerary preovulatory follicular reduction, *Fertil Steril* 76:820, 2001.
376. **Britt DW, Risinger ST, Mans M, Evans MI**, Anxiety among women who have undergone fertility therapy and who are considering multifetal pregnancy reduction: trends and implications, *J Matern Fetal Neonatal Med* 13:271, 2003.
377. **Berkowitz RL, Lynch L, Stone J, Alvarez M**, The current status of multifetal pregnancy reduction, *Am J Obstet Gynecol* 174:1265, 1996.
378. **Landy HJ, Keith LG**, The vanishing twin: a review, *Hum Reprod Update* 4:177, 1998.
379. **Lipitz S, Shulman A, Achiron R, Zalel Y, Seidman DS**, A comparative study of multifetal pregnancy reduction from triplets to twins in the first versus early second trimesters after detailed fetal screening, *Ultrasound Obstet Gynecol* 18:35, 2001.
380. **Dodd JM, Crowther CA**, Reduction of the number of fetuses for women with triplet and higher order multiple pregnancies, *Cochrane Database Syst Rev* (2):CD003932, 2003.
381. **Evans MI, Berkowitz RL, Wapner RJ, Carpenter RJ, Goldberg JD, Ayoub MA, Horenstein J, Dommergues M, Brambati B, Nicolaides KH, Holzgreve W, Timor-Tritsch IE**, Improvement in outcomes of multifetal pregnancy reduction with increased experience, *Am J Obstet Gynecol* 184:97, 2001.
382. **Yaron Y, Bryant-Greenwood PK, Dave N, Moldenhauer JS, Kramer RL, Johnson MP, Evans MI**,

- Multifetal pregnancy reductions of triplets to twins: comparison with nonreduced triplets and twins, *Am J Obstet Gynecol* 180:1268, 1999.
383. **Lipitz S, Reichman B, Uval J, Shalev J, Achiron R, Barkai G, Lusky A, Mashiach S**, A prospective comparison of the outcome of triplet pregnancies managed expectantly or by multifetal reduction to twins, *Am J Obstet Gynecol* 170:874, 1994.
  384. **Sebire NJ, D'Ercole C, Sepulveda W, Hughes K, Nicolaides KH**, Effects of embryo reduction from trichorionic triplets to twins, *Br J Obstet Gynaecol* 104:1201, 1997.
  385. **Ziadeh SM**, Perinatal outcome in 41 sets of triplets in Jordan, *Birth* 27:185, 2000.
  386. **Ata B, Rasillo LJ, Sukhdeo S, Son WY, Tan SL, Dahan MH**, Obstetric outcomes of IVF trichorionic triamniotic triplets which are spontaneously or electively reduced to twins, *J Assist Reprod Genet* 28:1217, 2011.
  387. **Wimalasundera RC**, Selective reduction and termination of multiple pregnancies, *Semin Fetal Neonatal Med* 15:327, 2010.
  388. **Anthoulakis C, Dagklis T, Mamopoulos A, Athanasiadis A**, Risks of miscarriage or preterm delivery in trichorionic and dichorionic triplet pregnancies with embryo reduction versus expectant management: a systematic review and meta-analysis, *Hum Reprod* 32:1351, 2017.
  389. **Dodd J, Crowther C**, Multifetal pregnancy reduction of triplet and higher-order multiple pregnancies to twins, *Fertil Steril* 81:1420, 2004.
  390. **Stone J, Ferrara L, Kamrath J, Getrajdman J, Berkowitz R, Moshier E, Eddleman K**, Contemporary outcomes with the latest 1000 cases of multifetal pregnancy reduction (MPR), *Am J Obstet Gynecol* 199:406.e1, 2008.
  391. **Razaz N, Avitan T, Ting J, Pressey T, Joseph KS**, Perinatal outcomes in multifetal pregnancy following fetal reduction, *CMAJ* 189:E652, 2017.
  392. **van de Mheen L, Everwijn SM, Knapen MF, Haak MC, Engels MA, Manten GT, Zondervan HA, Wirjosekarto SA, van Vugt JM, Erwich JJ, Bilardo CM, van Pampus MG, de Groot CJ, Mol BW, Pajkrt E**, Pregnancy outcome after fetal reduction in women with a dichorionic twin pregnancy, *Hum Reprod* 30:1807, 2015.
  393. **Mai Q, Hu X, Yang G, Luo Y, Huang K, Yuan Y, Zhou C**, Effect of letrozole on moderate and severe early-onset ovarian hyperstimulation syndrome in high-risk women: a prospective randomized trial, *Am J Obstet Gynecol* 216:42.e1, 2017.
  394. **Vasseur C, Rodien P, Beau I, Desroches A, Gerard C, de Poncheville L, Chaplot S, Savagner F, Croue A, Mathieu E, Lahlou N, Descamps P, Misrahi M**, A chorionic gonadotropin-sensitive mutation in the follicle-stimulating hormone receptor as a cause of familial gestational spontaneous ovarian hyperstimulation syndrome, *N Engl J Med* 349:753, 2003.
  395. **Smits G, Olatunbosun O, Delbaere A, Pierson R, Vassart G, Costagliola S**, Ovarian hyperstimulation syndrome due to a mutation in the follicle-stimulating hormone receptor, *N Engl J Med* 349:760, 2003.
  396. **Montanelli L, Delbaere A, Di Carlo C, Nappi C, Smits G, Vassart G, Costagliola S**, A mutation in the follicle-stimulating hormone receptor as a cause of familial spontaneous ovarian hyperstimulation syndrome, *J Clin Endocrinol Metab* 89:1255, 2004.
  397. **Goldsmann MP, Pedram A, Dominguez CE, Ciuffardi I, Levin E, Asch RH**, Increased capillary permeability induced by human follicular fluid: a hypothesis for an ovarian origin of the hyperstimulation syndrome, *Fertil Steril* 63:268, 1995.
  398. **Bergh PA, Navot D**, Ovarian hyperstimulation syndrome: a review of pathophysiology, *J Assist Reprod Genet* 9:429, 1992.
  399. **Levin ER, Rosen GF, Cassidenti DL, Yee B, Meldrum D, Wisot A, Pedram A**, Role of vascular endothelial cell growth factor in Ovarian Hyperstimulation Syndrome, *J Clin Invest* 102:1978, 1998.
  400. **Geva E, Jaffe RB**, Role of vascular endothelial growth factor in ovarian physiology and pathology, *Fertil Steril* 74:429, 2000.
  401. **Pellicer A, Albert C, Mercader A, Bonilla-Musoles F, Remohi J, Simon C**, The pathogenesis of ovarian hyperstimulation syndrome: in vivo studies investigating the role of interleukin-1beta, interleukin-6, and vascular

- endothelial growth factor, *Fertil Steril* 71:482, 1999.
402. **Revel A, Barak V, Lavy Y, Anteby E, Abramov Y, Schenker JJ, Amit A, Finci-Yeheskel Z, Mayer M, Simon A, Laufer N, Hurwitz A**, Characterization of intraperitoneal cytokines and nitrites in women with severe ovarian hyperstimulation syndrome, *Fertil Steril* 66:66, 1996.
  403. **Delbaere A, Bergmann PJ, Gervy-Decoster C, Deschodt-Lanckman M, de Maertelaer V, Staroukine M, Camus M, Englert Y**, Increased angiotensin II in ascites during severe ovarian hyperstimulation syndrome: role of early pregnancy and ovarian gonadotropin stimulation, *Fertil Steril* 67:1038, 1997.
  404. **Buyalos RP, Lee CT**, Polycystic ovary syndrome: pathophysiology and outcome with in vitro fertilization, *Fertil Steril* 65:1, 1996.
  405. **Golan A, Ron-el R, Herman A, Soffer Y, Weinraub Z, Caspi E**, Ovarian hyperstimulation syndrome: an update review, *Obstet Gynecol Surv* 44:430, 1989.
  406. **Ashrafi M, Bahmanabadi A, Akhond MR, Arabipoor A**, Predictive factors of early moderate/severe ovarian hyperstimulation syndrome in non-polycystic ovarian syndrome patients: a statistical model, *Arch Gynecol Obstet* 292:1145, 2015.
  407. **Lee TH, Liu CH, Huang CC, Wu YL, Shih YT, Ho HN, Yang YS, Lee MS**, Serum anti-Mullerian hormone and estradiol levels as predictors of ovarian hyperstimulation syndrome in assisted reproduction technology cycles, *Hum Reprod* 23:160, 2008.
  408. **Nakhuda GS, Chu MC, Wang JG, Sauer MV, Lobo RA**, Elevated serum mullerian-inhibiting substance may be a marker for ovarian hyperstimulation syndrome in normal women undergoing in vitro fertilization, *Fertil Steril* 85:1541, 2006.
  409. **Ocal P, Sahmay S, Cetin M, Irez T, Guralp O, Cepni I**, Serum anti-Mullerian hormone and antral follicle count as predictive markers of OHSS in ART cycles, *J Assist Reprod Genet* 28:1197, 2011.
  410. **Tal R, Seifer DB, Khanimov M, Malter HE, Grazi RV, Leader B**, Characterization of women with elevated antimullerian hormone levels (AMH): correlation of AMH with polycystic ovarian syndrome phenotypes and assisted reproductive technology outcomes, *Am J Obstet Gynecol* 211:59.e1, 2014.
  411. **Jayaprakasan K, Chan Y, Islam R, Haoula Z, Hopkisson J, Coomarasamy A, Raine-Fenning N**, Prediction of in vitro fertilization outcome at different antral follicle count thresholds in a prospective cohort of 1,012 women, *Fertil Steril* 98:657, 2012.
  412. **Forman RG, Frydman R, Egan D, Ross C, Barlow DH**, Severe ovarian hyperstimulation syndrome using agonists of gonadotropin-releasing hormone for in vitro fertilization: a European series and a proposal for prevention, *Fertil Steril* 53:502, 1990.
  413. **Delvigne A, Demoulin A, Smitz J, Donnez J, Koninckx P, Dhont M, Englert Y, Delbeke L, Darcis L, Gordts S, Puttemans P, Gerris J, Schoysman R, Leroy F**, The ovarian hyperstimulation syndrome in in vitro fertilization: a Belgian multicentric study. I. Clinical and biological features, *Hum Reprod* 8:1353, 1993.
  414. **Enskog A, Henriksson M, Unander M, Nilsson L, Brannstrom M**, Prospective study of the clinical and laboratory parameters of patients in whom ovarian hyperstimulation syndrome developed during controlled ovarian hyperstimulation for in vitro fertilization, *Fertil Steril* 71:808, 1999.
  415. **Practice Committee of the American Society for Reproductive Medicine. Electronic address ASRM@asrm.org, Practice Committee of the American Society for Reproductive Medicine**, Prevention and treatment of moderate and severe ovarian hyperstimulation syndrome: a guideline, *Fertil Steril* 106:1634, 2016.
  416. **Practice Committee of American Society for Reproductive Medicine**, Ovarian hyperstimulation syndrome, *Fertil Steril* 90:S188, 2008.
  417. **Mashiach S, Bider D, Moran O, Goldenberg M, Ben-Rafael Z**, Adnexal torsion of hyperstimulated ovaries in pregnancies after gonadotropin therapy, *Fertil Steril* 53:76, 1990.
  418. **Zosmer A, Katz Z, Lancet M, Konichezky S, Schwartz-Shoham Z**, Adult respiratory distress syndrome complicating ovarian hyperstimulation syndrome, *Fertil Steril* 47:524, 1987.
  419. **Borenstein R, Elhalah U, Lunenfeld B, Schwartz ZS**, Severe ovarian hyperstimulation syndrome: a reevaluated therapeutic approach, *Fertil Steril* 51:791, 1989.

420. **Navot D, Bergh PA, Laufer N**, Ovarian hyperstimulation syndrome in novel reproductive technologies: prevention and treatment, *Fertil Steril* 58:249, 1992.
421. **Abramov Y, Elchalal U, Schenker JG**, Pulmonary manifestations of severe ovarian hyperstimulation syndrome: a multicenter study, *Fertil Steril* 71:645, 1999.
422. **Wilson CA, Keye WR Jr**, A survey of adolescent dysmenorrhea and premenstrual symptom frequency. A model program for prevention, detection, and treatment, *J Adolesc Health Care* 10:317, 1989.
423. **Lincoln SR, Opsahl MS, Blauer KL, Black SH, Schulman JD**, Aggressive outpatient treatment of ovarian hyperstimulation syndrome with ascites using transvaginal culdocentesis and intravenous albumin minimizes hospitalization, *J Assist Reprod Genet* 19:159, 2002.
424. **Qublan HS, Al-Taani MI, Megdadi MF, Metri RM, Al-Ahmad N**, Multiple transvaginal ascitic fluid aspirations improves the clinical and reproductive outcome in patients undergoing in vitro fertilisation treatment complicated by severe early ovarian hyperstimulation syndrome, *J Obstet Gynaecol* 32:379, 2012.
425. **Aboulghar MA, Mansour RT, Serour GI, Amin Y**, Ultrasonically guided vaginal aspiration of ascites in the treatment of severe ovarian hyperstimulation syndrome, *Fertil Steril* 53:933, 1990.
426. **Rizk B, Aboulghar M**, Modern management of ovarian hyperstimulation syndrome, *Hum Reprod* 6:1082, 1991.
427. **Rinaldi ML, Spirtos NJ**, Chest tube drainage of pleural effusion correcting abdominal ascites in a patient with severe ovarian hyperstimulation syndrome: a case report, *Fertil Steril* 63:1114, 1995.
428. **Eshre Capri Workshop Group**, Venous thromboembolism in women: a specific reproductive health risk, *Hum Reprod Update* 19:471, 2013.
429. **Rova K, Passmark H, Lindqvist PG**, Venous thromboembolism in relation to in vitro fertilization: an approach to determining the incidence and increase in risk in successful cycles, *Fertil Steril* 97:95, 2012.
430. **Reed AP, Tausk H, Reynolds H**, Anesthetic considerations for severe ovarian hyperstimulation syndrome, *Anesthesiology* 73:1275, 1990.
431. **Grochowski D, Wolczynski S, Kuczynski W, Domitrz J, Szamatowicz J, Szamatowicz M**, Correctly timed coasting reduces the risk of ovarian hyperstimulation syndrome and gives good cycle outcome in an in vitro fertilization program, *Gynecol Endocrinol* 15:234, 2001.
432. **Al-Shawaf T, Zosmer A, Hussain S, Tozer A, Panay N, Wilson C, Lower AM, Grudzinskas JG**, Prevention of severe ovarian hyperstimulation syndrome in IVF with or without ICSI and embryo transfer: a modified 'coasting' strategy based on ultrasound for identification of high-risk patients, *Hum Reprod* 16:24, 2001.
433. **Ulug U, Bahceci M, Erden HF, Shalev E, Ben-Shlomo I**, The significance of coasting duration during ovarian stimulation for conception in assisted fertilization cycles, *Hum Reprod* 17:310, 2002.
434. **Sher G, Zouves C, Feinman M, Maassarani G**, 'Prolonged coasting': an effective method for preventing severe ovarian hyperstimulation syndrome in patients undergoing in-vitro fertilization, *Hum Reprod* 10:3107, 1995.
435. **Waldenstrom U, Kahn J, Marsk L, Nilsson S**, High pregnancy rates and successful prevention of severe ovarian hyperstimulation syndrome by 'prolonged coasting' of very hyperstimulated patients: a multicentre study, *Hum Reprod* 14:294, 1999.
436. **Kol S, Muchtar M**, Recombinant gonadotrophin-based, ovarian hyperstimulation syndrome-free stimulation of the high responder: suggested protocol for further research, *Reprod Biomed Online* 10:575, 2005.
437. **Lewit N, Kol S, Manor D, Itskovitz-Eldor J**, Comparison of gonadotrophin-releasing hormone analogues and human chorionic gonadotrophin for the induction of ovulation and prevention of ovarian hyperstimulation syndrome: a case-control study, *Hum Reprod* 11:1399, 1996.
438. **Fatemi HM, Popovic-Todorovic B, Humaidan P, Kol S, Banker M, Devroey P, Garcia-Velasco JA**, Severe ovarian hyperstimulation syndrome after gonadotropin-releasing hormone (GnRH) agonist trigger and "freeze-all" approach in GnRH antagonist protocol, *Fertil Steril* 101:1008, 2014.
439. **Alvarez C, Marti-Bonmati L, Novella-Maestre E, Sanz R, Gomez R, Fernandez-Sanchez M, Simon C, Pellicer A**, Dopamine agonist cabergoline reduces hemoconcentration and ascites in hyperstimulated women undergoing assisted reproduction, *J Clin Endocrinol Metab* 92:2931, 2007.

440. **Taheripanah R, Balash F, Anbiaee R, Mahmoodi M, Akbari Sene A**, Breast Cancer and Ovulation Induction Treatments, *Clin Breast Cancer* 18:395, 2018.
441. **Burkman RT, Tang MT, Malone KE, Marchbanks PA, McDonald JA, Folger SG, Norman SA, Strom BL, Bernstein L, Ursin G, Weiss LK, Daling JR, Simon MS, Spirtas R**, Infertility drugs and the risk of breast cancer: findings from the National Institute of Child Health and Human Development Women's Contraceptive and Reproductive Experiences Study, *Fertil Steril* 79:844, 2003.
442. **Crowley WF Jr, McArthur JW**, Simulation of the normal menstrual cycle in Kallman's syndrome by pulsatile administration of luteinizing hormone-releasing hormone (LHRH), *J Clin Endocrinol Metab* 51:173, 1980.
443. **Leyendecker G, Wildt L, Hansmann M**, Pregnancies following chronic intermittent (pulsatile) administration of Gn-RH by means of a portable pump ("Zyklomat")—a new approach to the treatment of infertility in hypothalamic amenorrhea, *J Clin Endocrinol Metab* 51:1214, 1980.
444. **Crowley WF Jr, Filicori M, Spratt DI, Santoro NF**, The physiology of gonadotropin-releasing hormone (GnRH) secretion in men and women, *Recent Prog Horm Res* 41:473, 1985.
445. **Filicori M, Flamigni C, Meriggiola MC, Cognigni G, Valdiserri A, Ferrari P, Campaniello E**, Ovulation induction with pulsatile gonadotropin-releasing hormone: technical modalities and clinical perspectives, *Fertil Steril* 56:1, 1991.
446. **Martin K, Santoro N, Hall J, Filicori M, Wierman M, Crowley WF Jr**, Clinical review 15: Management of ovulatory disorders with pulsatile gonadotropin-releasing hormone, *J Clin Endocrinol Metab* 71:1081A, 1990.
447. **Filicori M, Flamigni C, Dellai P, Cognigni G, Michelacci L, Arnone R, Sambataro M, Falbo A**, Treatment of anovulation with pulsatile gonadotropin-releasing hormone: prognostic factors and clinical results in 600 cycles, *J Clin Endocrinol Metab* 79:1215, 1994.
448. **Gill S, Taylor AE, Martin KA, Welt CK, Adams JM, Hall JE**, Specific factors predict the response to pulsatile gonadotropin-releasing hormone therapy in polycystic ovarian syndrome, *J Clin Endocrinol Metab* 86:2428, 2001.
449. **Braat DD, Schoemaker R, Schoemaker J**, Life table analysis of fecundity in intravenously gonadotropin-releasing hormone-treated patients with normogonadotropic and hypogonadotropic amenorrhea, *Fertil Steril* 55:266, 1991.
450. **Timmerman-van Kessel EC, Cikot RJ, Dargel-Donkers EJ, Zwertbroek W, van Dop PA, Schoot DC**, A randomized controlled study comparing the endocrine effects of pulsatile intravenous gonadotropin-releasing hormone after gonadotropin-releasing hormone agonist pretreatment versus clomiphene citrate in patients with polycystic ovary syndrome, *Fertil Steril* 73:1145, 2000.
451. **Braat DD, Ayalon D, Blunt SM, Bogchelman D, Coelingh Bennink HJ, Handelsman DJ, Heineman MJ, Lappohn RE, Lorijn RH, Rolland R, Willemsen WMP, Schoemaker J**, Pregnancy outcome in luteinizing hormone-releasing hormone induced cycles: a multicentre study, *Gynecol Endocrinol* 3:35, 1989.
452. **Filicori M, Flamigni C, Meriggiola MC, Ferrari P, Michelacci L, Campaniello E, Valdiserri A, Cognigni G**, Endocrine response determines the clinical outcome of pulsatile gonadotropin-releasing hormone ovulation induction in different ovulatory disorders, *J Clin Endocrinol Metab* 72:965, 1991.
453. **Jansen RP**, Pulsatile intravenous gonadotrophin releasing hormone for ovulation induction: determinants of follicular and luteal phase responses, *Hum Reprod* 8(Suppl 2):193, 1993.
454. **Santoro N, Wierman ME, Filicori M, Waldstreicher J, Crowley WF Jr**, Intravenous administration of pulsatile gonadotropin-releasing hormone in hypothalamic amenorrhea: effects of dosage, *J Clin Endocrinol Metab* 62:109, 1986.
455. **Filicori M, Campaniello E, Michelacci L, Pareschi A, Ferrari P, Bolelli G, Flamigni C**, Gonadotropin-releasing hormone (GnRH) analog suppression renders polycystic ovarian disease patients more susceptible to ovulation induction with pulsatile GnRH, *J Clin Endocrinol Metab* 66:327, 1988.
456. **Louvet JP, Harman SM, Schrieber JR, Ross GT**, Evidence of a role of androgens in follicular maturation, *Endocrinology* 97:366, 1975.
457. **Filicori M, Flamigni C, Campaniello E, Valdiserri A, Ferrari P, Meriggiola MC, Michelacci L, Pareschi A**, The abnormal response of polycystic ovarian disease patients to exogenous pulsatile gonadotropin-releasing hormone: characterization and management, *J Clin Endocrinol Metab* 69:825, 1989.

458. **Tranoulis A, Laios A, Pampanos A, Yannoukakos D, Loutradis D, Michala L**, Efficacy and safety of pulsatile gonadotropin-releasing hormone therapy among patients with idiopathic and functional hypothalamic amenorrhea: a systematic review of the literature and a meta-analysis, *Fertil Steril* 109:708.e8, 2018.
459. **Homburg R, Eshel A, Armar NA, Tucker M, Mason PW, Adams J, Kilborn J, Sutherland IA, Jacobs HS**, One hundred pregnancies after treatment with pulsatile luteinising hormone releasing hormone to induce ovulation, *BMJ* 298:809, 1989.
460. **Martin KA, Hall JE, Adams JM, Crowley WF Jr**, Comparison of exogenous gonadotropins and pulsatile gonadotropin-releasing hormone for induction of ovulation in hypogonadotropic amenorrhea, *J Clin Endocrinol Metab* 77:125, 1993.
461. **Carr JS, Reid RL**, Ovulation induction with gonadotropin-releasing hormone (GnRH), *Semin Reprod Endocrinol* 8:174, 1990.
462. **Schran HF, Bhuta SI, Schwarz HJ, Thorner MO**, The pharmacokinetics of bromocriptine in man, *Adv Biochem Psychopharmacol* 23:125, 1980.
463. **Bankowski BJ, Zacur HA**, Dopamine agonist therapy for hyperprolactinemia, *Clin Obstet Gynecol* 46:349, 2003.
464. **Ferrari C, Barbieri C, Caldara R, Mucci M, Codecasa F, Paracchi A, Romano C, Bohen M, Dubini A**, Long-lasting prolactin-lowering effect of cabergoline, a new dopamine agonist, in hyperprolactinemic patients, *J Clin Endocrinol Metab* 63:941, 1986.
465. **Friedman E, Adams EF, Hoog A, Gejman PV, Carson E, Larsson C, De Marco L, Werner S, Fahlbusch R, Nordenskjold M**, Normal structural dopamine type 2 receptor gene in prolactin-secreting and other pituitary tumors, *J Clin Endocrinol Metab* 78:568, 1994.
466. **Padilla SL, Person GK, McDonough PG, Reindollar RH**, The efficacy of bromocriptine in patients with ovulatory dysfunction and normoprolactinemic galactorrhea, *Fertil Steril* 44:695, 1985.
467. **Yamaguchi M, Aono T, Koike K, Nishikawa Y, Ikegami H, Miyake A, Tanizawa O**, Effects of nocturnal hyperprolactinemia on ovarian luteal function and galactorrhea, *Eur J Obstet Gynecol Reprod Biol* 39:187, 1991.
468. **Asukai K, Uemura T, Minaguchi H**, Occult hyperprolactinemia in infertile women, *Fertil Steril* 60:423, 1993.
469. **Fujimoto VY, Clifton DK, Cohen NL, Soules MR**, Variability of serum prolactin and progesterone levels in normal women: the relevance of single hormone measurements in the clinical setting, *Obstet Gynecol* 76:71, 1990.
470. **Suginami H, Hamada K, Yano K, Kuroda G, Matsuura S**, Ovulation induction with bromocriptine in normoprolactinemic anovulatory women, *J Clin Endocrinol Metab* 62:899, 1986.
471. **Isik AZ, Gulekli B, Zorlu CG, Ergin T, Gokmen O**, Endocrinological and clinical analysis of hyperprolactinemic patients with and without ultrasonically diagnosed polycystic ovarian changes, *Gynecol Obstet Invest* 43:183, 1997.
472. **Papaleo E, Doldi N, De Santis L, Marelli G, Marsiglio E, Rofena S, Ferrari A**, Cabergoline influences ovarian stimulation in hyperprolactinaemic patients with polycystic ovary syndrome, *Hum Reprod* 16:2263, 2001.
473. **Falaschi P, Rocco A, del Pozo E**, Inhibitory effect of bromocriptine treatment on luteinizing hormone secretion in polycystic ovary syndrome, *J Clin Endocrinol Metab* 62:348, 1986.
474. **Verhelst J, Abs R, Maiter D, van den Bruel A, Vandeweghe M, Velkeniers B, Mockel J, Lamberigts G, Petrossians P, Coremans P, Mahler C, Stevenaert A, Verlooy J, Raftopoulos C, Beckers A**, Cabergoline in the treatment of hyperprolactinemia: a study in 455 patients, *J Clin Endocrinol Metab* 84:2518, 1999.
475. **Factor SA**, Dopamine agonists, *Med Clin North Am* 83:415, vi, 1999.
476. **Wang AT, Mullan RJ, Lane MA, Hazem A, Prasad C, Gathaiya NW, Fernandez-Balsells MM, Bagatto A, Coto-Yglesias F, Carey J, Elraiyah TA, Erwin PJ, Gandhi GY, Montori VM, Murad MH**, Treatment of hyperprolactinemia: a systematic review and meta-analysis, *Syst Rev* 1:33, 2012.
477. **Ciccarelli E, Giusti M, Miola C, Potenzoni F, Sghedoni D, Camanni F, Giordano G**, Effectiveness and tolerability of long term treatment with cabergoline, a new long-lasting ergoline derivative, in hyperprolactinemic

patients, *J Clin Endocrinol Metab* 69:725, 1989.

478. **Katz E, Schran HF, Adashi EY**, Successful treatment of a prolactin-producing pituitary macroadenoma with intravaginal bromocriptine mesylate: a novel approach to intolerance of oral therapy, *Obstet Gynecol* 73:517, 1989.
479. **Ginsburg J, Hardiman P, Thomas M**, Vaginal bromocriptine—clinical and biochemical effects, *Gynecol Endocrinol* 6:119, 1992.
480. **Motta T, de Vincentiis S, Marchini M, Colombo N, D’Alberton A**, Vaginal cabergoline in the treatment of hyperprolactinemic patients intolerant to oral dopaminergics, *Fertil Steril* 65:440, 1996.
481. **Turkalj I, Braun P, Krupp P**, Surveillance of bromocriptine in pregnancy, *JAMA* 247:1589, 1982.
482. **Weil C**, The safety of bromocriptine in long-term use: a review of the literature, *Curr Med Res Opin* 10:25, 1986.
483. **Czeizel A, Kiss R, Racz K, Mohori K, Glaz E**, Case-control cytogenetic study in offspring of mothers treated with bromocriptine during early pregnancy, *Mutat Res* 210:23, 1989.
484. **Raymond JP, Goldstein E, Konopka P, Leleu MF, Merceron RE, Loria Y**, Follow-up of children born of bromocriptine-treated mothers, *Horm Res* 22:239, 1985.
485. **Schade R, Andersohn F, Suissa S, Haverkamp W, Garbe E**, Dopamine agonists and the risk of cardiac-valve regurgitation, *N Engl J Med* 356:29, 2007.
486. **Zanettini R, Antonini A, Gatto G, Gentile R, Tesei S, Pezzoli G**, Valvular heart disease and the use of dopamine agonists for Parkinson’s disease, *N Engl J Med* 356:39, 2007.
487. **Roth BL**, Drugs and valvular heart disease, *N Engl J Med* 356:6, 2007.



# Assisted Reproductive Technologies

**Assisted reproductive technologies (ART)** encompass all techniques involving direct manipulation of oocytes outside of the body. The first and still most common form of ART is in vitro fertilization (IVF), but other related techniques also reside within the realm of ART. The success of modern ART has completely revolutionized both the evaluation and treatment of infertility. Some traditional diagnostic methods and treatments have been rendered obsolete, and others have only limited applications because ART is simply more effective. The trend is clear and certain to continue.

IVF involves a sequence of highly coordinated steps beginning with ovarian stimulation with exogenous gonadotropins, followed by retrieval of oocytes from the ovaries under the guidance of transvaginal ultrasonography, fertilization and embryo culture in the laboratory, and transcervical transfer of embryos into the uterus. The first pregnancy resulting from IVF was reported in 1976 and was ectopic.<sup>1</sup> The first child resulting from IVF was born in 1978.<sup>2</sup> Over the subsequent 40 years, ART has been greatly refined and expanded, resulted in millions of births worldwide, and now accounts for 1–4.5% of all births in the United States and Europe.<sup>3,4</sup> ART includes methods for assisted fertilization by intracytoplasmic sperm injection (ICSI) using sperm isolated from the ejaculate or obtained by microsurgical epididymal sperm aspiration (MESA) or testicular sperm extraction (TESE), assisted embryo hatching, and preimplantation genetic testing (PGT) for aneuploidy (PGT-A; previously called preimplantation genetic screening, PGS) and/or PGT for monogenic disease (PGT-M; previously called preimplantation genetic diagnosis, PGD). In most cases, IVF is used to help an infertile couple conceive their own biologic child; however, donor sperm, donor oocytes, and gestational surrogates also play an important role in modern ART. Medically indicated or elective fertility preservation ([Chapter 29](#)) is another area where ART is increasingly being used.

Other forms of ART include tubal transfer of oocytes and sperm (gamete intrafallopian transfer, GIFT), zygotes (zygote intrafallopian transfer, ZIFT), or embryos (tubal embryo transfer, TET) via laparoscopy. Whereas these more invasive techniques once had certain advantages over traditional IVF for some infertile couples, they now have only very limited, if any, indications.

A truly comprehensive discussion of ART is well beyond the scope of any single book chapter. The objective here is to provide an overview of the indications for ART,

the most common methods for ovarian stimulation, oocyte retrieval, sperm recovery, fertilization, and gamete/embryo transfer, and the results and complications of ART, with emphasis on newly developing technologies and areas of controversy.

# INDICATIONS FOR IVF

---

IVF was first developed as a method to overcome infertility resulting from irreparable tubal disease but now is applied much more broadly for the treatment of almost all causes of infertility. IVF is most clearly indicated when infertility results from one or more causes having no other effective treatment; severe tubal disease relating to previous infection or advanced endometriosis and severe male factor infertility are the most obvious examples. IVF also is often the best treatment for couples with multifactor infertility because it can address or overcome all contributing causes at the same time. IVF is a legitimate treatment option for women with age-related or otherwise unexplained infertility and also represents the treatment of last resort when other treatments fail.

In women with premature ovarian failure or reproductive aging and healthy women beyond normal reproductive age, IVF using oocytes from a young donor is highly successful. For women with normal ovaries but no functional uterus (müllerian agenesis, severe intrauterine adhesions, previous hysterectomy) and those with medical disorders that preclude pregnancy due to serious health risks, IVF with embryo transfer to a gestational surrogate still offers the possibility of genetically related offspring. IVF using oocytes from a donor and embryos transferred to a gestational carrier also allows male same-sex couples to pursue parenthood. In couples who carry autosomal or sex-linked genetic disorders or balanced chromosomal translocations, IVF with PGT can avoid the risk of delivering an affected child.

# Tubal Factor Infertility

Before the advent of IVF, women with irreparable bilateral tubal obstruction were essentially sterile, and the prognosis for those with less severe distal disease was only fair. In the modern era of ART, surgical treatments are declining in importance, and the prognosis for women with tubal factor infertility has improved dramatically. Approximately 14% of patients using ART have a primary diagnosis of tubal factor infertility.<sup>5</sup> The relative advantages and disadvantages of surgery and IVF for the treatment of tubal factor infertility and the factors bearing on a choice between the two are discussed in-depth in [Chapter 25](#) and summarized here.

**Reconstructive surgery remains a viable option for young women with mild distal tubal obstruction or peritubular adhesions (because postoperative live birth rates can exceed 50%),<sup>6,7,8</sup> but IVF is the treatment of choice for women with severe distal disease.** Results achieved with surgery have varied, but success rates (10–35%) are generally lower than with IVF, and the risk of ectopic pregnancy is higher (5–20%).<sup>5,9,10,11,12</sup> In 2015, the overall IVF live birth rate (per cycle start) for U.S. women with tubal factor infertility (all ages) was 24%; however, this rate increases with decreasing age.<sup>5</sup> IVF is also the best treatment for women who remain infertile for more than a year after tubal surgery (the likelihood for success diminishes progressively with time after operation), for older women with significant distal tubal disease (cycle fecundity is low after distal tubal surgery and time is limited), and for women with recurrent distal tubal obstruction (repeated attempts to correct distal tubal occlusive disease are rarely successful).

Although not candidates for reconstructive surgery, women with severe distal tubal disease still can benefit from surgery prior to IVF. **A substantial body of evidence indicates that** pregnancy, implantation, and delivery rates are decreased by approximately 50% and abortion rates are increased in the presence of **communicating hydrosalpinges (proximal patency and distal occlusion)**. The mechanism for the adverse effect of hydrosalpinges on IVF outcomes could involve mechanical interference with implantation or toxic effects on the embryo or endometrium.<sup>13,14,15,16,17,18</sup> A 2010 systematic review including five randomized trials involving 646 women observed that the odds of achieving an ongoing pregnancy were twice as great after laparoscopic salpingectomy for hydrosalpinges before IVF (OR = 2.14, CI = 1.23–3.73).<sup>19</sup> Laparoscopic proximal occlusion of the tubes also increased the odds of clinical pregnancy compared to no intervention (OR = 4.66, CI = 2.47–10.01), and neither surgical procedure was superior.<sup>19</sup> **This is likely to be true even when only one tube is affected.** Moreover, removal or proximal occlusion of unilateral hydrosalpinx seems to improve chances of spontaneous pregnancy.<sup>19,20,21</sup>

**Proximal tubal occlusion** observed during hysterosalpingography (HSG) often is a reaction to the procedure itself and results from “cornual spasm” or other technical pitfalls of the procedure ([Chapter 25](#)). **Efforts to confirm the diagnosis are justified; otherwise, many women may needlessly undergo IVF.** Common methods include repeated HSG<sup>22</sup> and laparoscopic “chromotubation.”<sup>23,24,25</sup> Fluoroscopic or hysteroscopic selective tubal cannulation both establish the diagnosis and provide the means for successful treatment.<sup>22,23,26,27,28,29,30</sup> Microsurgical segmental resection and anastomosis is another proven treatment for true proximal tubal obstruction<sup>31,32,33,34</sup> but requires uncommon technical expertise. IVF is the obvious alternative when cannulation is contraindicated (salpingitis isthmica nodosa) or technically unsuccessful and when infertility persists for more than 6–12 months after the procedure.

Approximately 1 million U.S. women have an elective **tubal sterilization** procedure each year; up to 30% regret the decision, and about 1% later request its reversal.<sup>35,36,37,38</sup> The most commonly cited reasons for regret include new relationships, changes in family planning goals, and death of a child. Regrets are more common in younger women, those who were unaware of the spectrum of contraceptive options, women whose decision for sterilization was influenced by a third party (partner, other family member, friend, or physician), and in those sterilized postpartum or after an abortion.<sup>36,37,39,40</sup> Women 30 years old or younger are twice as likely as older women to express regret, 3.5–18 times more likely to request information about reversal of the procedure, and approximately 8 times more likely to have a sterilization reversal or IVF.<sup>37,38,41</sup>

**Young women sterilized using rings or clips and women having no other infertility factors have the best surgical prognosis; success rates are lower for older women, those sterilized by cautery (particularly multiple-burn techniques), and women with other infertility factors.**<sup>42,43,44,45,46,47,48,49</sup> **Although conception rates are quite good (45–82%) after microsurgical tubal anastomosis in properly selected candidates, IVF is a legitimate alternative to surgery, particularly for older women, those with a poor surgical prognosis or preferring to avoid surgery, and women who desire only one additional pregnancy.**

# Endometriosis

The association between endometriosis and infertility and the pathogenic mechanisms involved are considered at length in [Chapter 32](#). In brief summary, 20–40% of infertile women have endometriosis, and accumulated evidence indicates that fertility decreases with the severity of the disease. Endometriosis may cause infertility by distorting adnexal anatomy and interfering with ovum capture<sup>50</sup> or possibly by impairing oocyte development, early embryogenesis, or endometrial receptivity.<sup>51,52,53,54,55,56,57,58</sup> IVF should be expected to overcome any anatomical obstacles, and although the mechanisms by which IVF can conquer functional disorders of oocyte, embryo, or endometrial development are not clear, outcomes in women with endometriosis suggest it can. Endometriosis is the primary diagnosis in approximately 9% of patients using ART, although this number is likely an underestimate as not all patients with infertility undergo a diagnostic test for endometriosis.<sup>5</sup>

Treatment options for infertile women with advanced stages of endometriosis include conservative surgical treatment and IVF. For those with severe pain symptoms, surgery is the most logical treatment. However, whether surgical treatment of advanced endometriosis improves IVF outcome beyond symptom relief is controversial.<sup>59</sup> Data from uncontrolled case series suggest that cumulative pregnancy rates 1–3 years after surgical treatment are approximately 50% for women with endometriomas<sup>52,53,54,55</sup> and about 30% for women with complete cul-de-sac obliteration.<sup>60,61,62</sup> Patient selection and careful surgical technique are important because ovarian function can be compromised by excision of excessive tissue or damage to hilar vessels<sup>63,64</sup>; the risk of ovarian failure after excision of bilateral ovarian endometriomas is approximately 2.5%.<sup>65</sup> Preoperative oocyte or embryo cryopreservation should be considered prior to surgery in women at high risk of ovarian failure, for example, those with bilateral endometrioma and already low ovarian reserve. **After surgical treatment, the choice between expectant management, empirical treatment, and IVF should be based on age, surgical results, and the severity of any other coexisting infertility factors. The endometriosis fertility index, an externally validated staging system, incorporating female age, duration of infertility, history of a prior pregnancy, tubal and ovarian status at conclusion of surgery, and American Fertility Society score can aid in identification of couples with a poor prognosis for non-IVF conception and avoid loss of time without effective treatment.**<sup>66,67,68,69,70</sup>

Asymptomatic infertile women with advanced endometriosis, including those with ovarian endometriomas, can be treated surgically or proceed directly to IVF. Even though endometriomas can grow during ovarian stimulation and prevent access to some follicles during oocyte retrieval, there is no evidence to indicate that endometriomas

have any important adverse effect on the response to ovarian stimulation or IVF outcomes.<sup>71,72,73</sup> Consequently, endometriomas can be left untreated before IVF. Aspiration of endometriomas before ovarian stimulation or at time of oocyte retrieval has been associated with an increased risk for developing an ovarian abscess and is not recommended,<sup>74,75,76,77</sup> although the risk appears quite low.<sup>73,78</sup>

Treatment options for asymptomatic women with known or suspected minimal or mild endometriosis and no other infertility factors include expectant management, surgical treatment, empiric treatment with clomiphene or exogenous gonadotropins and IUI, and IVF. In older women, those with other coexisting infertility factors, and women who have failed other forms of treatment, IVF is often the best overall choice.

Results of a 2006 systematic review including three randomized trials involving 165 infertile women with endometriosis of varying severity suggest that treatment with a GnRH agonist for 3–6 months before IVF can increase the odds of clinical pregnancy (OR = 4.28, CI = 2.0–9.15).<sup>79</sup> However, because prolonged treatment with a GnRH agonist also can decrease response to ovarian stimulation, this regimen should be used cautiously in those with diminished ovarian reserve (DOR). Indeed, some retrospective series suggest similar IVF outcome with GnRH agonists or antagonists in women with endometriosis.<sup>80,81</sup> Therefore, long-term GnRH antagonist use in endometriosis may be used to achieve similar IVF results; however, they have not yet been tested in clinical trials.

# Male Factor Infertility

Poor semen quality is the sole cause of infertility in approximately 20% of infertile couples and an important contributing factor in another 20–40%.<sup>82,83</sup> Many infertile men have disorders that can be corrected medically or surgically if properly diagnosed and treated, allowing them to achieve natural conception with their partners. In others, mild but important semen abnormalities can be overcome by IUI. **When treatment is not possible or fails, IVF and ICSI, using sperm isolated from the ejaculate or extracted from the epididymis or testis, offers realistic hope for success.** The evaluation and treatment of male factor infertility are the focus of [Chapter 26](#). Discussion here is limited to the indications for ART.<sup>83</sup>

The likelihood of male factor infertility is increased in men whose ejaculates consistently exhibit a sperm concentration under 15 million sperm/mL, less than 32% progressive motility, or fewer than 4% morphologically normal sperm (strict criteria, WHO III standard).<sup>84</sup> The overall odds of male infertility increase with the number of abnormal parameters in the subfertile range; the probability is 2–3 times higher when one is abnormal, 5–7 times higher when two are abnormal, and approximately 16 times greater when all three parameters are abnormal.<sup>85</sup> **Additional genetic evaluation is indicated for men with severe oligospermia (sperm concentration <5 million/mL) (Chapter 26).**

Medical or surgical treatment to improve or normalize poor semen quality is always the first and best option, when that is possible. When treatment is not feasible or proves unsuccessful, timely IUI can help to improve cycle fecundity in some couples with male factor infertility. **Best results with IUI are achieved when the number of total motile sperm in the insemination specimen exceeds a threshold of approximately 10 million.**<sup>86,87,88</sup> Higher counts do not further increase the likelihood for success,<sup>86</sup> and IUI is seldom successful when fewer than 1 million total motile sperm are inseminated.<sup>89,90</sup> The effect of sperm morphology on IUI success is controversial, and predictive value of percentage of morphologically normal sperm is low, yet most studies suggest lower pregnancy rates with lesser than 4% sperm with normal morphology.<sup>91,92,93,94,95,96</sup> However, a low percentage of morphologically normal sperm alone does not necessitate omitting IUI in favor of IVF. The likelihood of success with IUI also decreases with increasing female partner age and with coexisting infertility factors (ovulatory dysfunction, uterine and tubal factors).

**When IUI is not possible, the prognosis for success with IUI is poor, or IUI proves unsuccessful, IVF is the logical alternative.** Approximately 35% of patients using ART have a primary diagnosis of male factor infertility.<sup>5</sup>



Conventional fertilization rates in IVF cycles are decreased when the total motile sperm count is less than 2–3 million (postwash).<sup>97,98</sup> Similarly, conventional fertilization rates also are decreased when less than 4% of sperm are morphologically normal (also called teratospermia).<sup>97,99,100,101,102</sup> Although severe teratospermia is widely accepted as an indication for assisted fertilization by ICSI, some, after observing no differences in fertilization, pregnancy, and live birth rates achieved with ICSI, compared with conventional fertilization, do not regard isolated teratospermia as an indication for ICSI.<sup>103,104,105,106</sup>

# Ovulatory Dysfunction

For women with ovulatory disorders (hypogonadotropic hypogonadism, polycystic ovary syndrome (PCOS), thyroid disorders, hyperprolactinemia), ovulation induction alone generally restores fertility ([Chapter 27](#)), but for some who require exogenous gonadotropins, ovulation induction proves difficult to achieve or consistently results in excessive ovarian stimulation and cycle cancellation for undue risk of ovarian hyperstimulation syndrome (OHSS) and high-order multiple gestation. For these difficult patients, IVF is an obvious treatment alternative, making their high sensitivity to gonadotropin stimulation an asset instead of a liability. Ovulatory dysfunction is the primary diagnosis in approximately 14% of patients using ART.<sup>5</sup>

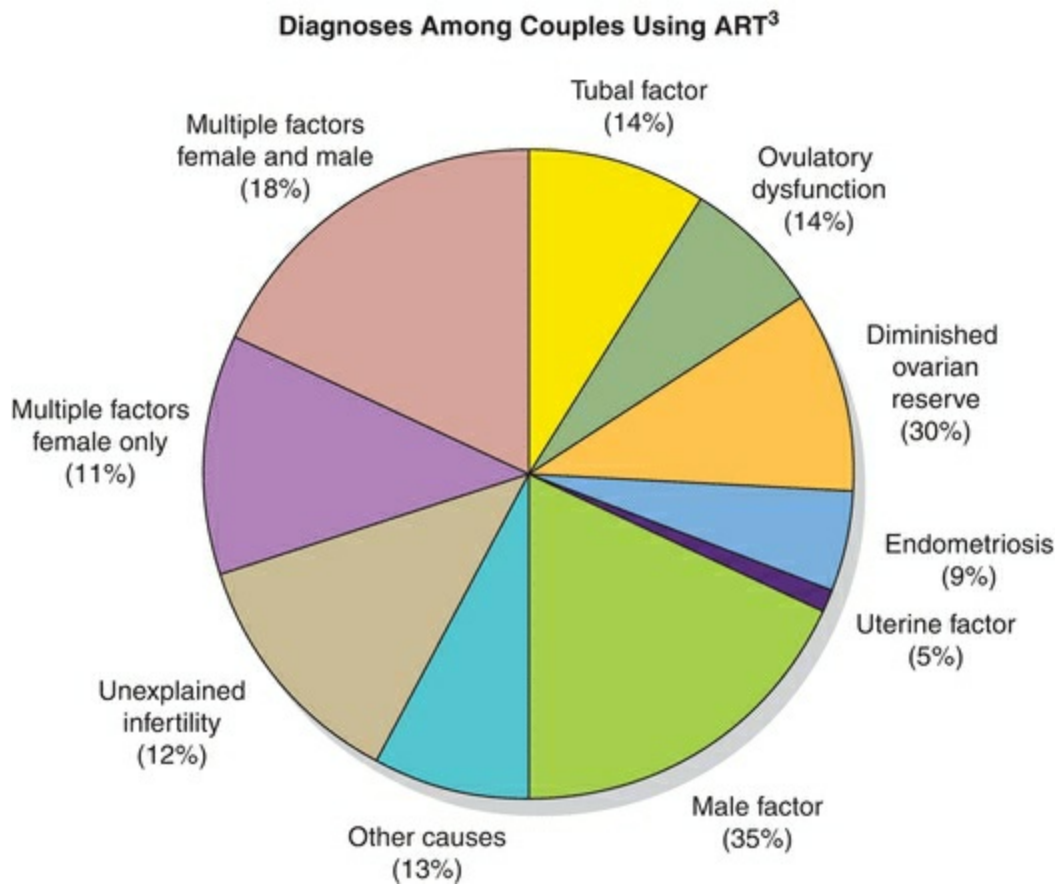
# Unexplained Infertility

The incidence of unexplained infertility ranges from 10% to as high as 30% among infertile populations, depending on diagnostic criteria.<sup>107,108,109</sup> For women with unexplained infertility, treatment options (cycle fecundability in parentheses) include expectant management (2–4%),<sup>110</sup> combined treatment with IUI and clomiphene (5–10%)<sup>111,112,113</sup> or gonadotropins (7–10%),<sup>111,114,115</sup> and IVF (25–45%).<sup>5,116</sup> As might be expected, success rates with all forms of treatment decline progressively with increasing age of the female partner.

Among couples with unexplained infertility, IVF is the preferred treatment for some and the treatment of last resort for others. **In either case, there is no question that IVF is the most effective treatment for couples with unexplained infertility.** A higher incidence of fertilization failure has been observed in several, but not all, studies of IVF outcomes in couples with unexplained infertility,<sup>117,118,119,120</sup> prompting many to recommend ICSI when IVF is planned. However, whether ICSI improves fertilization rate in the absence of male factor infertility remains controversial. It also seems unlikely that ICSI improves clinical outcome over that achieved with IVF in unexplained infertility.<sup>121,122,123</sup> Approximately 14% of patients using ART have a diagnosis of unexplained infertility.<sup>5</sup>

# Diminished Ovarian Reserve and Ovarian Failure

Increasing number of women undergo ART due to DOR. In the United States, DOR was the primary diagnosis for 10% of ART cycles in 2003, 14% in 2008, and 19% in 2015; the number of fresh IVF cycles using nondonor oocytes performed for women with DOR almost doubled reaching over 13,000 cycles during the same time period (Figure 28.1).<sup>5</sup>



**FIGURE 28.1**

IVF using oocytes from a known or anonymous young donor was first developed for women with premature ovarian failure or menopause.<sup>124</sup> Now, oocyte donation is most commonly performed in women over age 42, those with grossly abnormal ovarian reserve test results, and women whose IVF cycles consistently yield poor quality embryos. Similar to the trend observed with DOR, the number of women undergoing oocyte donation in the United States almost doubled in the past decade.<sup>5</sup>

# Other Indications for IVF and Related Technologies

Although less commonly encountered, there are a number of other legitimate indications for IVF and related ART procedures.

**Fertility preservation** is fast becoming a common indication for ART. Women with cancer or other illnesses requiring treatments (chemotherapy, radiation therapy) that pose a serious threat to future fertility may be candidates for urgent IVF and cryopreservation of embryos before treatment begins, if time and health allow.<sup>125</sup> Oocyte cryopreservation is a viable option for women in similar circumstances having no male partner<sup>126</sup> and is an option for young women at risk for premature ovarian failure, healthy aging women, and others who anticipate delayed childbearing.<sup>127,128</sup>

For women with normal ovaries but no functional uterus, due to a developmental anomaly (müllerian agenesis), advanced disease (multiple myomas, severe intrauterine adhesions), or a previous hysterectomy, and for women with medical conditions that preclude pregnancy due to serious health risks, **gestational surrogacy** offers the opportunity to have their own genetic offspring.<sup>129,130</sup>

Male same-sex couples utilize egg donation and gestational surrogacy to achieve parenthood. IVF may also be utilized by female same-sex couples to achieve pregnancy using eggs retrieved from one partner, fertilized by donor sperm, and transferred to the other partner, in a process termed reciprocal IVF.

For couples at risk for transmitting a specific genetic disease or abnormality to their offspring, IVF with **preimplantation genetic testing for monogenic diseases (PGT-M, also called preimplantation genetic diagnosis or PGD)** provides the means to identify and exclude affected embryos and thereby avoid that risk. PGT-M is applied most commonly in couples who carry autosomal recessive and sex-linked disorders or harbor a balanced chromosomal translocation.<sup>131</sup> Women who carry a genetic disorder not amenable to diagnosis by PGT-M or who decline PGT-M may be candidates for oocyte donation. **Preimplantation genetic testing for aneuploidy (PGT-A, also called preimplantation genetic screening or PGS)** applies the same technology in couples having no known chromosomal or genetic abnormality in efforts to identify and exclude aneuploid embryos.<sup>132</sup>

# PROGNOSTIC FACTORS

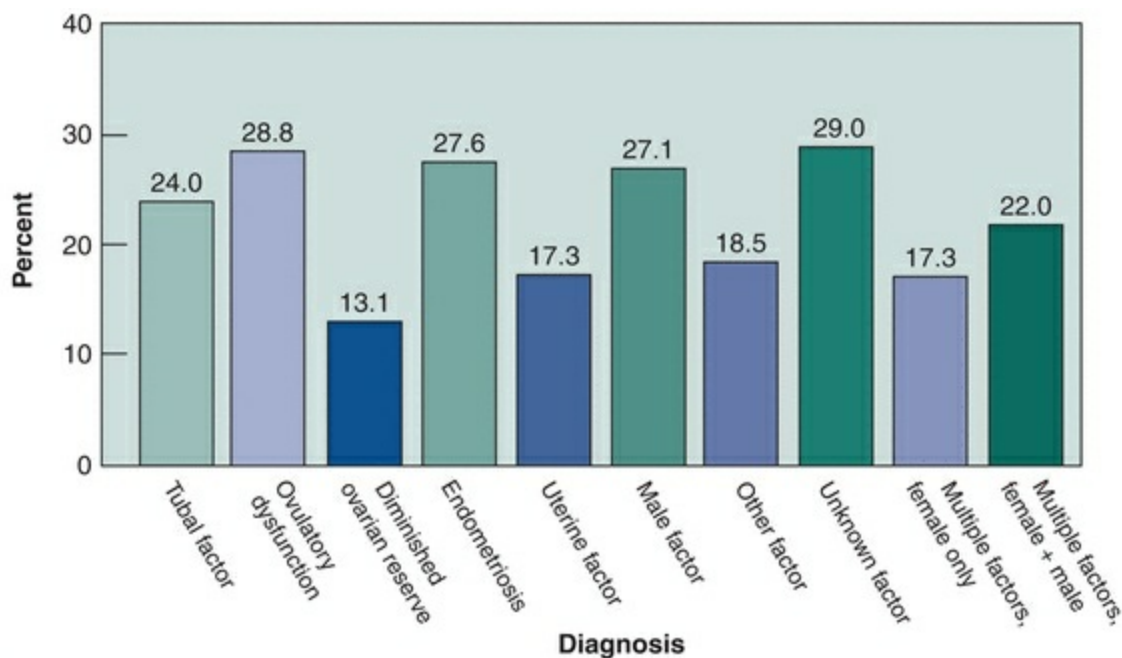
---

The probability for success with IVF relates to several factors, many of which are unfortunately not known until the treatment cycle is well underway (response to stimulation) or even nearing completion (number and quality of embryos). Before an IVF cycle begins, the primary prognostic indicators are maternal age, ovarian reserve, diagnosis, and past reproductive performance.

# Maternal Age

The relationship between maternal age and fertility and the physiology of reproductive aging are discussed in detail in [Chapter 25](#) only briefly summarized again here, where the focus is on the relationship between maternal age and IVF outcomes.

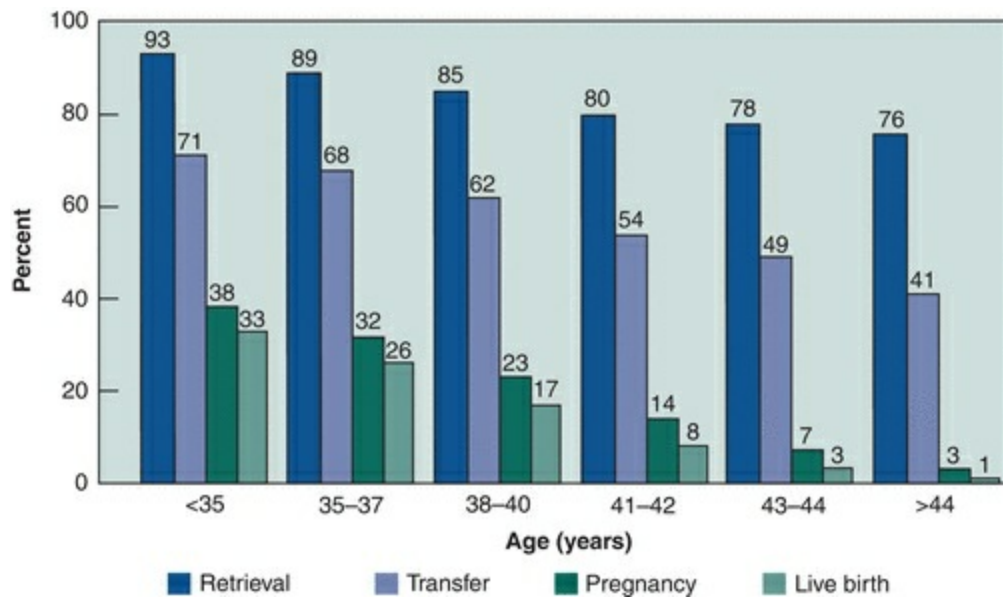
The average age of women using ART in the United States is 35 years.<sup>5</sup> **Maternal age is the one most important factor in determining the likelihood for success with IVF.** Although IVF can overcome most causes of infertility in younger women, it cannot negate or reverse the age-related decrease in biologic fertility in older women, particularly those over the age of 40.<sup>133</sup> The success rates achieved with IVF, like natural fertility rates, decline as maternal age increases.<sup>5</sup> **The pattern reflects a progressive decline in response to ovarian stimulation, resulting in fewer oocytes and embryos, and a decreased embryo implantation rate, due to declining oocyte quality and increasing embryo aneuploidy.**<sup>134,135,136,137,138</sup> In 2015, the percentage of cycles that resulted in a live birth from fresh nondonor oocytes, by maternal age, was 33% for women under age 35, 26% for ages 35–37 years, 17% for ages 38–40 years, 8% for ages 41–42 years, 3% for ages 43–44 years, and 1% for over 44 years.<sup>5</sup> The pattern of decreasing success rates achieved with IVF parallels that associated with other, less complex, forms of treatment for infertility ([Figure 28.2](#)).<sup>139</sup>



\* Total percentages are greater than 100% because more than one diagnosis can be reported for each cycle.

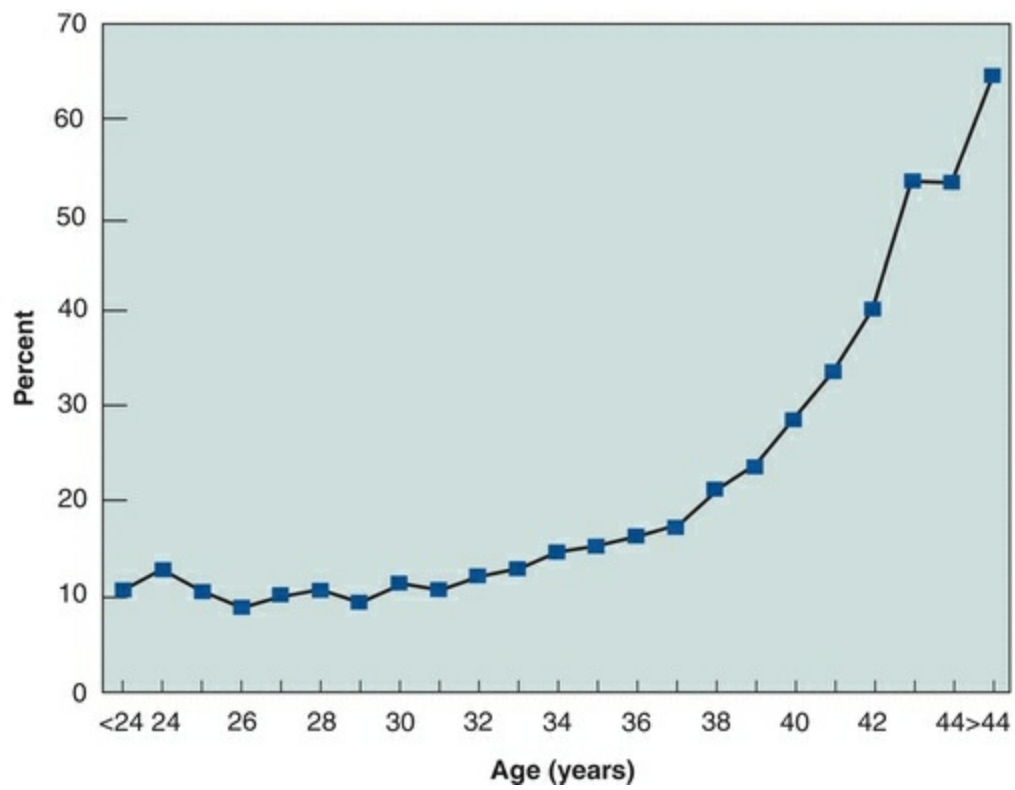
**FIGURE 28.2**

Evidence from numerous lines of investigation indicates that the age-dependent decrease in success rates achieved with IVF relates primarily to an increasing prevalence of aneuploidy in aging oocytes,<sup>140,141,142,143</sup> which is reflected in the incidence of miscarriage in pregnancies achieved with ART: less than 15% for women under age 35, 20% at age 38, 29% at age 40, and nearly 60% for women over age 44 (Figure 28.3).<sup>5</sup> In a case series of IVF cycles involving women aged 45–49, 70/231 cycles (30%) were cancelled before oocyte retrieval and 34/161 retrievals (21%) resulted in a pregnancy, but only 5/34 pregnancies (15%) and 5/231 cycles (2%) resulted in a live birth (Figure 28.4).<sup>144</sup>



**FIGURE 28.3**





**FIGURE 28.4**

# Ovarian Reserve

A retrospective analysis of all 400,135 IVF cycles performed in the United Kingdom over a 17-year period spanning 1991–2008, showed a strong association between the number of oocytes and live birth rate, which rose with an increasing number of eggs  $\approx 15$ .<sup>145</sup> In the same study, live birth rate plateaued between 15 and 20 eggs and steadily declined beyond 20 eggs. This decline is most likely due to impaired endometrial receptivity in a hyperstimulated cycle, rather than an adverse effect of stimulation on oocytes. The major determinant of number of oocytes collected is the ovarian reserve. The concept of ovarian reserve, generally defined as the size and quality of the remaining ovarian follicular pool, and the various methods for its measurement are discussed in detail in [Chapter 25](#). In brief summary, the total number of oocytes in any given woman is genetically determined and inexorably declines throughout life, from approximately 1–2 million at birth, to about 300,000 at puberty, 25,000 at age 40, and fewer than 1,000 at menopause.<sup>146,147,148</sup> The rate of follicular depletion is not constant but increases gradually as the number of follicles remaining decreases.<sup>149,150,151,152</sup> As the size of the remaining follicular pool decreases, circulating inhibin B levels (derived primarily from smaller antral follicles) decrease, resulting in lower levels of feedback inhibition and a progressive increase in serum follicle-stimulating hormone (FSH) levels, most noticeably during the early follicular phase.<sup>153,154,155,156,157,158,159,160,161</sup> Increasing intercycle FSH concentrations stimulate earlier follicular recruitment, resulting in advanced follicular development early in the cycle, an earlier rise in serum estradiol levels, a shorter follicular phase, and decreasing overall cycle length.<sup>162,163,164</sup>

The physiology of reproductive aging provides the foundation for all contemporary tests of ovarian reserve. Traditionally, the basal early follicular phase (cycle days 2–4) FSH level was the most common test; however, antimüllerian hormone (AMH) and antral follicle count (AFC) are being used increasingly more often.

As basal FSH levels increase, peak estradiol levels during stimulation, the number of oocytes retrieved, and the probability for pregnancy or live birth decline steadily.<sup>165,166,167,168,169,170,171</sup> **With current assays (using IRP 78/549), FSH levels greater than 10 IU/L (10–20 IU/L) have high specificity (80–100%) for predicting poor response to stimulation, but their sensitivity for identifying such women is generally low (10–30%) and decreases with the threshold value.**<sup>170</sup> Although most women who are tested have a normal result, including those with a DOR, the test is still useful because those with abnormal results are very likely to have DOR.

**The basal serum estradiol concentration, by itself, has little value as an ovarian reserve test**<sup>172,173,174,175</sup> **but can provide additional information that helps in the interpretation of the basal FSH level.** An early elevation in serum estradiol reflects

advanced follicular development and early selection of a dominant follicle (as classically observed in women with advanced reproductive aging) and will suppress FSH concentrations, thereby possibly masking an otherwise obviously high FSH level indicating DOR. When the basal FSH is normal and the estradiol concentration is elevated (>60–80 pg/mL), the likelihood of poor response to stimulation is increased and the chance for pregnancy is decreased.<sup>176,177,178,179</sup> When both FSH and estradiol are elevated, ovarian response to stimulation is likely to be very poor.

Antimüllerian hormone derives from preantral and small antral follicles. The number of small antral follicles correlates with the size of the residual follicular pool, and AMH levels decline progressively with age, becoming undetectable near the menopause.<sup>180,181,182,183</sup> Overall, lower AMH levels have been associated with poor response to ovarian stimulation and low oocyte yield, embryo quality, pregnancy rates, and cumulative live birth rates,<sup>184,185,186,187,188</sup> but studies correlating mean AMH levels with IVF outcomes have not yielded threshold values that can be applied confidently in clinical care.<sup>172,185,186,189,190,191,192,193,194,195,196,197,198</sup> **In the general IVF population, low AMH threshold values (0.2–0.7 ng/mL) have had 40–97% sensitivity, 78–92% specificity, 22–88% positive predictive value (PPV), and 97–100% negative predictive value (NPV) for predicting poor response to stimulation (<3 follicles or <2–4 oocytes) but have proven neither sensitive nor specific for predicting pregnancy.**<sup>184,199,200,201</sup> In women at low risk for DOR, values of 2.5–2.7 ng/mL have had 83% sensitivity, 82% specificity, 67–77% PPV, and 61–87% NPV for clinical pregnancy.<sup>173,202</sup> A study in women at high risk for DOR (involving older women, those with an elevated FSH, or history of poor response to stimulation) observed that an undetectable AMH had 76% sensitivity, 88% specificity, 68% PPV, and 92% NPV for three or fewer follicles.<sup>185</sup> In 2018, a large prospective cohort study of more than 2,000 women younger than 38 years old undergoing their first IVF cycle found that the odds of a given fertilized oocyte developing to a blastocyst, being aneuploid or leading to a live birth after euploid transfer were no different if the oocyte was retrieved from a cycle with AMH in the less than 10th percentile (corrected for age) compared to an oocyte retrieved in a cycle with those parameters in the 25–75th percentile. AMH level in the less than 10th percentile did more commonly result in cycle cancellation prior to retrieval and after retrieval prior to transfer due to global arrest of embryos. These findings suggest that while young women with evidence of quantitative depletion of ovarian reserve have lower live birth rates per stimulation cycle, this is not simply attributable to poor oocyte quality.<sup>198</sup>

The AFC is the total number of antral follicles measuring 2–10 mm in both ovaries during the early follicular phase and is a useful measure of ovarian reserve because it quantifies the number of follicles at the stage of development that responds to FSH

stimulation.<sup>203,204,205,206,207</sup> Several studies have observed a relationship between the AFC and response to ovarian stimulation in IVF cycles. In the general IVF population, including women at low and high risk for DOR, an AFC threshold value of three to four follicles has high specificity (73–100%) for predicting poor response to ovarian stimulation and failure to conceive (64–100%) but relatively low sensitivity for both end points (9–73% for poor response and 8–33% for failure to conceive).<sup>174,208,209,210,211,212,213,214</sup> **The PPV and NPV of AFC have varied widely in studies. A low AFC has high specificity for predicting poor response to ovarian stimulation and treatment failure, making it a useful test, but its low sensitivity limits its overall clinical utility.**

In summary, both AFC and AMH level are useful tools to identify patients who are likely to have a poor, normal, or hyperresponse to exogenous gonadotropin stimulation.<sup>211,215,216,217</sup> **However, none of the ovarian reserve tests currently in use is an accurate predictor of pregnancy in IVF cycles, unless extreme abnormal threshold values are applied, which results in very low sensitivity for identifying women having a poor prognosis.**<sup>218</sup> The tests are adequate for predicting poor response, which does have prognostic value, although not as great in young women as in older women.<sup>219,220,221</sup> Although ovarian reserve tests have become a routine element of pretreatment evaluation for couples planning IVF, it can be argued that routine testing has limited clinical utility in the large majority of patients and can be misleading, especially in women at low risk for having a DOR.<sup>222</sup>

Ovarian reserve tests always should be interpreted with caution. Rigid application of test results risks inappropriate recommendations for treatment or for no treatment, and both must be avoided. An abnormal test result does not preclude the possibility of pregnancy. **Except perhaps at the extremes, test results should not be used to deny treatment but only to obtain prognostic information that may help to guide the choice of treatment and best use of available resources. Although the probability of pregnancy may be low, many with abnormal test results will achieve pregnancy if afforded the chance. Ultimately, regardless of the prognosis, the success rate for any individual woman will be 0% or 100%.**

# Diagnosis and Past Reproductive Performance

Although the average overall IVF live birth rate per cycle is approximately 24% for all women in the United States, success rates vary, to some extent, with the cause of infertility. In 2015, the success rates for women with tubal factor infertility, ovulatory dysfunction, endometriosis, male factor, and unexplained infertility were above average, and those for women with multiple infertility factors, a uterine factor, and DOR were below average. Whereas these data are useful, it is important to note that criteria for the different diagnoses are not standardized and likely vary among treatment centers ([Table 28.1](#)).

## TABLE 28.1 Live Birth Rates in IVF Cycles, By Diagnosis, 2015<sup>5</sup>

**Infertility Diagnosis****Live Births/Cycle**

Unexplained infertility (Unknown factor)	29.0%
Ovulatory dysfunction	28.8%
Endometriosis	27.6%
Male factor	27.1%
Tubal factor	24%
Multiple factors, female and male	22%
Other factor	18.5%
Uterine factor	17.3%
Multiple factors, female only	17.3%
Diminished ovarian reserve	13.1%

Women with a previous live birth are more likely to succeed with IVF than nulliparous women. In all age categories, success rates for women having one or more previous live births are modestly higher (1–5%) than for women with no previous live births, while women with previous unsuccessful ART cycles attain lower live birth rates beginning after two previous failures.<sup>5</sup> A history of an earlier unsuccessful pregnancy has no effect on success rates.<sup>5</sup>

## Other Prognostic Factors

As discussed earlier in the section focused on indications for ART, there is substantial evidence indicating that hydrosalpinges adversely affect IVF outcomes and that salpingectomy or proximal tubal occlusion before IVF increases the likelihood for achieving a live birth by twofolds.<sup>19</sup> Laparoscopic salpingectomy before IVF is generally recommended for women with hydrosalpinges, even when only one tube is affected. A study evaluating the cost-effectiveness of preliminary salpingectomy concluded that the procedure decreases the average cost per live birth, compared to no treatment.<sup>223</sup> One concern with salpingectomy or even tubal occlusion or ligation is its impact on ovarian reserve. Despite contradictory results in early reports, salpingectomy does not impact ovarian reserve, except perhaps when it is done for ectopic pregnancy. Salpingectomy does not significantly decrease serum AMH concentration, ovarian response to stimulation or clinical pregnancy rates with IVF.<sup>224,225</sup> Ovarian stimulation parameters, implantation, and clinical pregnancy rates are similar in women who underwent salpingectomy or laparoscopic proximal tubal occlusion.<sup>226</sup>

Ultrasound-guided aspiration of hydrosalpingeal fluid at the time of oocyte retrieval has been suggested as an alternative treatment.<sup>227</sup> The procedure is effective in improving IVF outcome as compared to no intervention, simpler and less costly than surgical options. However, salpingectomy or proximal tubal occlusion improve success rates more than fluid aspiration with regard to ongoing pregnancy, clinical pregnancy, ectopic pregnancy, and miscarriage rates.<sup>228</sup> Moreover, the fluid reaccumulates rapidly.<sup>229</sup> Aspiration of hydrosalpingeal fluid should be reserved for women who are likely to have severe intra-abdominal adhesions prone to complications with pelvic surgery.

Essure is a 2-mm-thick and 4-cm-long microplug, primarily used as a contraceptive device. Essure coil inserts have been used for occlusion of hydrosalpinges prior to IVF. Hysteroscopic placement of Essure coils is relatively easy; however, clinical pregnancy, implantation, and live birth rates following Essure are significantly lower than those achieved with laparoscopic management (salpingectomy or proximal occlusion) of hydrosalpinges.<sup>230</sup> Some evidence suggest that miscarriage rate is higher following Essure blockage of hydrosalpinges, as compared with other interventions.<sup>231</sup> Similar to hydrosalpinx aspiration, currently, Essure can be regarded as a second-line intervention for women under high risk of intra-abdominal adhesions. It is noteworthy that, in late July of 2018, the manufacturer announced its plans to stop selling Essure in the United States, possibly as a result of injury and increasing safety restrictions from regulators.

The effect of uterine myomas on IVF outcomes depends on their location. They alter

global endometrial receptivity through the production of cytokines rather than simply a mechanical effect.<sup>232,233,234</sup> There is a clear consensus that submucous myomas have significant adverse effect on clinical pregnancy rates (OR = 0.3, CI = 0.1–0.7) and delivery rates (OR = 0.3, CI = 0.1–0.8).<sup>235,236,237,238,239,240</sup> Available data also support the conclusion that submucous myomas increase risk for miscarriage by more than threefolds,<sup>239,240</sup> while the effect of intramural myomas that do not distort the cavity on the risk of miscarriage is less clear.<sup>241</sup> Results of early studies examining the effect of intramural myomas on IVF outcomes are inconsistent, with some finding adverse effects,<sup>242,243,244,245,246</sup> and others not.<sup>239,247,248,249,250,251,252</sup> Large-scale prospective studies report significantly lower implantation, pregnancy, ongoing pregnancy, and live birth rates in women with intramural myomas.<sup>245,246</sup> A 2010 systematic review of the effect of intramural myomas without uterine cavity involvement on IVF outcome included 19 observational studies comprising 6,087 IVF cycles.<sup>253</sup> Live birth rate was significantly decreased (RR = 0.79, 95% CI = 0.70–0.88). It is noteworthy that when results from the only two prospective studies reporting live birth rate were pooled, the relative reduction in live birth was 40% (RR = 0.60, 95% CI = 0.41–0.87). Likewise, clinical pregnancy rate was decreased by 21% (RR = 0.79, 95% CI = 0.70–0.88), and implantation rate was decreased by a relative 13% (RR = 0.87, 95% CI = 0.73–1.03).<sup>253</sup> The effect appears to be related to both myoma size and proximity to the endometrium. All of the evidence concerning the effects of subserosal myomas is consistent in finding no evidence of adverse effects on IVF outcomes. **In sum, the accumulated body of evidence indicates that submucous myomas reduce IVF success rates by approximately 70%, intramural myomas by approximately 20–40%, and subserosal myomas have no adverse impact on outcomes. Submucous myomas increase risk for miscarriage after successful IVF at least threefolds and intramural myomas by more than half. Submucous and large proximal intramural fibroids should be removed prior to IVF.**<sup>254</sup>

## Tobacco Use

All smoking women should be strongly encouraged to stop smoking before IVF because smoking decreases the likelihood for success.<sup>255,256,257</sup>



# EVALUATION BEFORE IVF

---

Individuals and couples planning IVF require additional specific evaluation before a treatment cycle begins. At a minimum, evaluation generally includes a test of ovarian reserve, a current assessment of semen quality, infectious disease screening, and imaging of the uterine cavity.

**Ovarian reserve tests** (basal FSH, AMH, AFC) have value for predicting response to gonadotropin stimulation and therefore can be helpful in planning treatment. If a threshold value with high specificity for detecting DOR is applied, the test can accurately identify women at high risk for poor response and treatment failure.

**Semen quality** should be assessed shortly before the treatment cycle is scheduled to start, even when earlier diagnostic evaluation revealed normal semen parameters, to ensure there has been no appreciable change that might affect the choice between conventional fertilization and ICSI. Sperm cryopreservation is prudent when semen quality is severely abnormal or there is reason to anticipate difficulty with obtaining a fresh specimen on the day of oocyte retrieval. Although fertilization rates achieved with frozen-thawed sperm may be somewhat lower than when fresh sperm are used, pregnancy rates are comparable.<sup>258,259,260</sup>

**Infectious disease screening** recommended for both partners includes human immunodeficiency virus (HIV), hepatitis B (hepatitis B surface antigen), hepatitis C (hepatitis C antibody), and syphilis (rapid plasma reagin), for the protection of medical and laboratory staff, protection of any fetus that may result from IVF, and protection against the risk for cross-contamination of cryopreserved embryos in storage. Whereas some advocate routine testing for chlamydia and gonorrhea in the female partner, others choose to limit evaluation to women with tubal factor infertility or other risk factors. Testing for antibodies to rubella and varicella in women undergoing IVF should be performed for timely immunization, if indicated.

**Imaging of the uterine cavity** before a cycle of treatment identifies submucosal myomas or endometrial polyps that may interfere with implantation or have an adverse effect on pregnancy outcome. An HSG performed earlier during the diagnostic evaluation may suffice if entirely normal and relatively recent (within approximately 6 months), but sonohysterography and hysteroscopy are the more sensitive and preferred methods. Routine office hysteroscopy before IVF was expected to identify potentially significant abnormalities such as polyps, myomas, adhesions, or septa in 10–20% of patients without symptoms.<sup>261,262,263</sup> However, two multicenter randomized controlled trials suggest that routine hysteroscopy prior to an IVF cycle does not improve outcomes over routine imaging.<sup>264,265</sup> Many prefer sonohysterography to hysteroscopy because it is easier to perform, is highly sensitive, and also can detect hydrosalpinges and

unsuspected ovarian pathology.<sup>266,267,268</sup>

Many clinicians would also perform a **trial transfer** to determine the technique required to achieve an atraumatic embryo transfer and to identify women whose transfer may be difficult to accomplish, although the orientation of the uterus can change when the ovaries are enlarged after stimulation.<sup>269,270,271,272</sup>

# OVARIAN STIMULATION REGIMENS

---

The ideal ovarian stimulation regimen for IVF should have a low cancellation rate; minimize drug costs, risks, and side effects; require limited monitoring for practical convenience; and maximize cumulative live birth rate per oocyte retrieval procedure, that is, cumulative chances of one or more live births after exhausting all fresh and frozen embryos generated from a single oocyte retrieval. Singleton pregnancy delivered at term is the ultimate goal of ART.

There are three components of a typical ovarian stimulation regimen for IVF; the first is exogenous gonadotropins to stimulate multifollicular growth, the second is GnRH analogues (antagonist or agonist) to prevent spontaneous ovulation before oocyte retrieval, and the third is LH activity in the form of human chorionic gonadotropin (hCG) to induce oocyte maturation. The source and type of gonadotropin, for example, endogenous or exogenous, human menopausal gonadotropin or recombinant, the type of GnRH analogue, that is, agonistic or antagonistic, vary according to the selected protocol.

Numerous regimens have been described, ranging from no stimulation (natural cycles), to minimal stimulation (clomiphene citrate) or mild stimulation (sequential treatment with clomiphene citrate and low-dose exogenous gonadotropins), to aggressive stimulation (high-dose exogenous gonadotropins, alone or in combination with a gonadotropin-releasing hormone agonist or antagonist).

# Natural Cycle

The first birth resulting from IVF derived from a single oocyte collected in a natural ovulatory cycle.<sup>2</sup> Compared to stimulated IVF cycles, natural cycle IVF offers a number of attractive advantages. Natural cycle IVF involves only monitoring the spontaneous cycle and retrieving a single oocyte before the midcycle LH surge occurs. It is physically less demanding, requires little or no medication, decreases costs,<sup>273,274</sup> and all but eliminates risks for multiple pregnancy and OHSS. The chief disadvantages of natural cycle IVF are high cancellation rates due to premature LH surges and ovulation and the comparatively low success rate of approximately 7%.<sup>275</sup>

When oocyte retrieval is based on detection of the midcycle rise in LH, careful and frequent monitoring is required and procedures are difficult to schedule efficiently. Alternatively, exogenous hCG can be administered when the lead follicle reaches a size consistent with maturity, thereby better defining the optimum time for oocyte retrieval.<sup>274</sup> Adjuvant treatment with a GnRH antagonist also can be used to prevent a premature LH surge but requires “add-back” treatment with exogenous FSH, and success rates are still quite low, ranging up to 14% per cycle in nonrandomized trials.<sup>276,277,278,279</sup> In one large cohort study involving 844 treatment cycles in 350 good prognosis patients, the cancellation rate was 13%, the pregnancy rate was 8% per cycle, and the cumulative pregnancy rate after three “modified natural IVF cycles” was 21%.<sup>280</sup> In a cohort of infertile couples with male factor infertility, success rates in modified natural cycles have reached as high as 13% per cycle, with a cumulative pregnancy rate of 44% after six treatment cycles.<sup>281</sup> Since the number of oocytes retrieved is positively correlated with pregnancy rates,<sup>145</sup> natural or modified natural cycles are not the first choice for women who can produce multiple follicles with gonadotropin stimulation. However, they can be a reasonable compromise for women who are expected to grow one or two follicles despite gonadotropin stimulation.

# Clomiphene Citrate

Clomiphene citrate was the first method of ovarian stimulation used in IVF,<sup>282,283</sup> but now has been almost entirely replaced by more effective stimulation regimens using human menopausal gonadotropins hMG or FSH, in combination with a GnRH agonist or antagonist.<sup>284</sup>

Clomiphene (100 mg daily) usually is administered for 5–8 days, beginning on cycle day 3, and induces development of two or more follicles in most normally ovulating women,<sup>285,286,287</sup> although egg yields (1–3) are only slightly greater than in unstimulated cycles and substantially lower than in cycles stimulated with exogenous gonadotropins.<sup>287,288,289</sup> Cycle cancellation rates are somewhat lower than in natural cycles, and the numbers of oocytes retrieved, embryos transferred, and pregnancy rates are greater. As in natural cycles, exogenous hCG is administered when the lead follicle reaches mature size and a GnRH antagonist can be used to prevent a premature endogenous LH surge.

Sequential treatment with clomiphene (100 mg daily for 5 days) and modest doses of exogenous gonadotropins (150–225 IU daily beginning on the last day of clomiphene treatment or the day after) stimulates multifollicular development more effectively than treatment with clomiphene alone.<sup>290,291,292</sup> Drug costs and monitoring requirements are moderately higher but still substantially less than in standard stimulation regimens involving higher-dose gonadotropin treatment after down-regulation with a long-acting GnRH agonist (described below).<sup>293,294</sup> In one comparative trial, higher cancellation rates and lower pregnancy rates were observed in sequential clomiphene/gonadotropin compared to gonadotropin/GnRH agonist cycles.<sup>294</sup> In another, the sequential stimulation regimen yielded fewer oocytes and embryos, but pregnancy rates were similar and the risks of OHSS were lower.<sup>293</sup> Adding a GnRH antagonist to the treatment regimen can prevent premature LH surges and improve outcomes but also increases costs. In a randomized trial, sequential clomiphene/gonadotropin stimulation and GnRH antagonist treatment yielded a pregnancy rate comparable to that achieved with a more aggressive standard treatment protocol,<sup>295</sup> confirming the results of two earlier retrospective studies,<sup>296,297</sup> although contrasting with those of another observing lower pregnancy rates.<sup>298</sup>

Apart from its common use as a stimulant for ovaries, clomiphene can help prevent premature LH surges in IVF cycles. Clomiphene may be used continuously until the day of ovulation trigger; this simplifies the protocol and reduces the cost of medication, as GnRH analogues are not needed. Large retrospective case series of minimal ovarian stimulation with clomiphene reported premature ovulation rates around 2.5%, attesting

to effectiveness of clomiphene in preventing premature LH surges.<sup>299</sup> Overall protocols that use clomiphene both to stimulate ovaries and inhibit LH surge are reported to result in an average number of oocytes collected between 1.5 and 2.5, cycle cancellation rates between 49% and 66%, clinical pregnancy rates at the range of 15–17%, and live birth rates at the range of 9.5–12.2%.<sup>299,300,301,302</sup> Regardless of the details of the protocols, studies that use mainly CC for ovarian stimulation yield a relatively lower number of oocytes with comparable clinical pregnancy rates (albeit being about 10% lower) than conventional stimulation cycles.

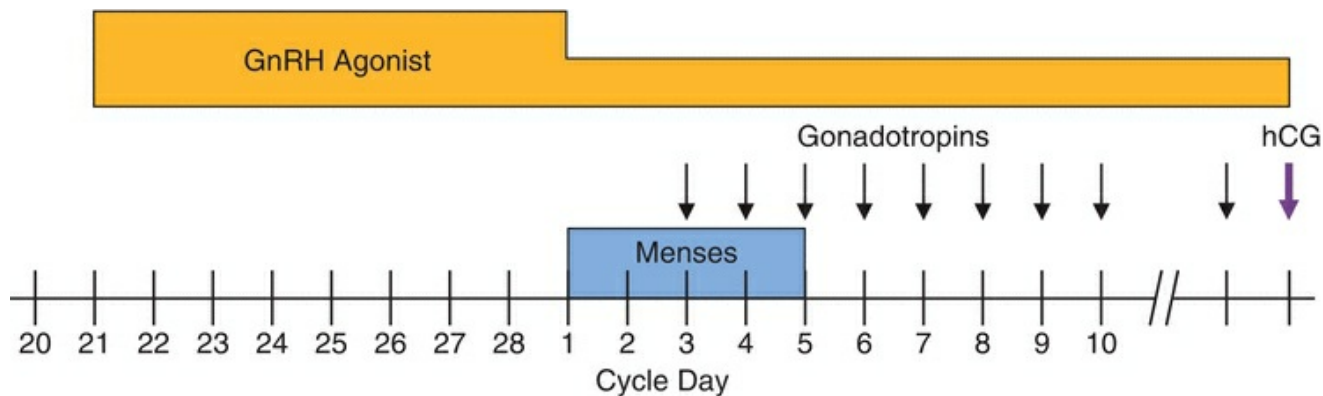
# GnRH Agonist Down-Regulation Gonadotropin Stimulation—The “Long” Protocol

The introduction of long-acting GnRH agonists in the late 1980s revolutionized the approach to ovarian stimulation in ART by providing the means to suppress endogenous pituitary gonadotropin secretion and thereby prevent a premature LH surge during exogenous gonadotropin stimulation. Adjuvant treatment with a GnRH agonist eliminated the need for frequent serum LH measurements and assuaged fears of premature luteinization, which previously had required cancellation of approximately 20% of all IVF cycles before oocyte retrieval.<sup>303,304,305</sup> Because fewer than 2% of cycles are complicated by a premature LH surge after down-regulation with a GnRH agonist,<sup>269</sup> stimulation could continue until follicles were larger and more mature. Numerous clinical trials subsequently demonstrated that egg yields and pregnancy rates were significantly higher than in cycles stimulated with exogenous gonadotropins alone.<sup>306,307</sup> Moreover, GnRH agonist treatment offered the welcome additional advantage of scheduling flexibility, allowing programs to coordinate cycle starts for groups of women simply by varying the duration of GnRH agonist suppression. Not surprisingly, the “long protocol” quickly became the preferred ovarian stimulation regimen for all forms of ART. Its only disadvantages are that GnRH agonist treatment sometimes blunts the response to gonadotropin stimulation and increases the dose and duration of gonadotropin therapy required to stimulate follicular development. The combined costs of the additional gonadotropins and the agonist itself increase the total cost of treatment substantially. **Nevertheless, because GnRH agonists have more advantages than disadvantages, the long protocol became and has remained the standard ovarian stimulation regimen in IVF cycles until more patient-friendly protocols utilizing GnRH antagonists gained widespread acceptance.**

In the typical cycle, GnRH agonist treatment begins during the midluteal phase, approximately 1 week after ovulation, at a time when endogenous gonadotropin levels are at or near their nadir and the acute release of stored pituitary gonadotropins in response to the agonist, known as the “flare” effect, is least likely to stimulate a new wave of follicular development.<sup>308,309</sup> GnRH agonist treatment can be scheduled to begin on cycle day 21 (assuming a normal cycle of approximately 28-day duration), but many prefer to first confirm that ovulation has occurred by measuring the serum progesterone concentration. In women who do not cycle predictably, oral contraceptives (OC) can be used to control the onset of menses, starting GnRH agonist treatment 1 week before their discontinuation. In the United States, leuprolide acetate (administered by SC injection) is the most commonly used GnRH agonist. In Europe and elsewhere, buserelin acetate (administered by SC injection or intranasal spray) and triptorelin

(administered subcutaneously) are more commonly used<sup>310</sup>; all work equally well. For leuprolide, the usual treatment regimen begins with 1.0 mg daily for approximately 10 days or until onset of menses or gonadotropin stimulation, decreasing to 0.5 mg daily thereafter until the ovulation trigger. A single dose of a longer-acting depot form of GnRH agonist (leuprolide, goserelin) offers greater convenience, but evidence indicates the total dose and duration of gonadotropin stimulation required are increased significantly when depot forms of the agonists are used.<sup>311</sup>

Gonadotropin stimulation begins after confirming that effective pituitary down-regulation has been achieved (serum estradiol level <30–40 pg/mL, no follicles >10 mm in diameter). Some women require longer durations of treatment to achieve suppression or may develop an ovarian cyst.<sup>303</sup> The significance of an ovarian cyst has been controversial. Whereas some investigators have observed that baseline cysts are associated with a poorer response to gonadotropin stimulation, decreased numbers of oocytes and embryos, and lower overall IVF success rates,<sup>312,313,314</sup> others have not.<sup>315,316,317,318,319</sup> **Overall, the weight of available evidence suggests that women who develop cysts or require longer durations of GnRH agonist treatment to achieve suppression are more likely to respond poorly to gonadotropin stimulation and less likely to achieve pregnancy.** Cyst aspiration immediately before stimulation does not appear to effect rates of live birth, clinical pregnancy, number of follicles recruited, or number of oocytes collected. Since cyst aspiration requires anesthesia, extra cost, psychological stress, and risk of surgical complications, it is probably not warranted in the absence of another indication (**Figure 28.5**).<sup>320</sup>



**FIGURE 28.5**

The initial dose of exogenous gonadotropins is tailored to the needs of the individual woman. Typical starting doses range between 150 and 300 IU of urinary FSH (uFSH), recombinant FSH (rFSH), or urinary menotropins (hMG) daily, depending on age, the



results of ovarian reserve testing, body weight, and the response observed in any previous stimulation cycles. However, there is an ongoing discussion regarding individualized dosing versus administering a standard dose of 150 IU/day for all women undergoing ovarian stimulation for IVF.<sup>321,322,323,324</sup> A multicenter trial conducted in The Netherlands categorized 1,032 women according to anticipated ovarian response as assessed by AFC and compared cumulative live birth rates over 18 months between women who received either the standard starting dose of 150 IU/day or 450 IU/day (women with AFC  $\leq 8$ ), 225 IU/day (women with AFC 8–10), or 100 IU/day (women with AFC  $> 15$ ).<sup>321,323</sup> Women with AFC less than 11 had similar cumulative live birth rates (43.2% vs. 45.6%) and time to ongoing pregnancy (212 vs. 197 days) regardless of FSH dosing, despite women receiving higher doses had significantly more oocytes collected (7.6 vs. 6.4), significantly lower incidence of poor response (35% vs. 50%), and significantly higher incidence of hyperresponse (8.6% vs. 3.4%) and treatment costs. Likewise, cumulative live birth rates (66.3% vs. 69.5%) and time to ongoing pregnancy (185 vs. 191 days) were similar between women with AFC greater than 15, who received 100 IU/day or 150 IU/day doses, respectively. Critics suggest the use of more complex models for dose selection, which include other markers of ovarian reserve; for example, AMH, body weight, or collection of more oocytes can improve outcomes or decrease the risk of OHSS.<sup>325,326,327</sup>

Numerous clinical trials and meta-analyses have compared outcomes in cycles stimulated with uFSH, rFSH, or hMG, with or without GnRH agonist pretreatment, concluding that there is no compelling evidence to indicate the superiority of one gonadotropin preparation over others.<sup>328,329,330,331</sup> However, a 2011 systematic review including 11 trials comparing outcomes in cycles stimulated with rFSH or hMG, involving 3,179 patients, observed a significant difference in live birth rate (OR = 0.84, CI = 0.72–0.99) favoring hMG.<sup>332</sup>

Recombinant DNA technology has been used to develop a longer-acting form of rFSH. Corifollitropin alfa comprises a  $\alpha$ -subunit identical to that of FSH and a  $\beta$ -subunit produced by the fusion of the C-terminal peptide from the  $\beta$ -subunit of chorionic gonadotropin (hCG) to the  $\beta$ -subunit of FSH. Corifollitropin alfa has a half-life 3 times longer than standard rFSH (95 vs. 32 hours).<sup>333,334</sup> A single dose (100  $\mu$ g for women  $\leq 60$  kg, 150  $\mu$ g for those  $> 60$  kg) can induce and sustain multifollicular growth for a week in women receiving ovarian stimulation for IVF. Controlled ovarian stimulation with corifollitropin yields similar or significantly higher numbers of oocytes and good quality embryos, as well as similar ongoing pregnancy rates compared to women stimulated with daily rFSH injections. Stimulation characteristics, embryology and clinical outcomes are also similar, and multiple pregnancy or OHSS rates are not increased over daily FSH regimen. Corifollitropin alfa molecule does not seem to be

immunogenic and does not induce neutralizing antibody formation. Drug hypersensitivity and injection site reactions are not increased. Incidence and nature of adverse events, serious adverse events, and rate of congenital malformations are reported to be similar to daily FSH injections.<sup>335,336</sup> This product is not available in the United States.

The low levels of LH secretion remaining after down-regulation with a GnRH agonist are sufficient to support normal follicular development in most women stimulated with uFSH or rFSH alone,<sup>337</sup> because only about 1% of LH receptors must be occupied to sustain normal levels of steroidogenesis.<sup>338</sup> However, in some women treated only with FSH, LH levels are markedly suppressed (<1 IU/L) and may be inadequate.<sup>339,340</sup> In such cycles, the dose and duration of gonadotropin stimulation required is higher, peak estradiol levels are lower, and the numbers of oocytes and embryos may be reduced.<sup>341,342</sup> Extremely low LH levels also may adversely affect fertilization, implantation, and pregnancy rates<sup>343,344,345,346,347</sup> and have been associated with a higher incidence of biochemical pregnancy and early pregnancy loss.<sup>348,349</sup> Whether LH activity improves clinical outcome of ovarian stimulation is controversial. A 2014 meta-analysis comparing rFSH alone and rFSH with recombinant LH concluded that the addition of rLH did not increase the number of oocytes collected.<sup>350</sup> However, consistent with the above mentioned Cochrane review,<sup>332</sup> rLH was associated with a small but statistically significant improvement in clinical pregnancy rate (rate ratio [RR] = 1.09, 95% CI = 1.01–1.18).<sup>350,351</sup> Even though the authors concluded that addition of rLH was associated with a more prominent increase in clinical pregnancy rates in poor responders, as well as significantly higher number of oocytes collected, this was not confirmed in several subsequent RCTs.<sup>352,353,354,355,356</sup> In sum, the evidence indicates **there may be a subgroup of women who could benefit from supplemental rLH or hMG during ovarian stimulation.** In the absence of any reliable method for identifying such women, and in light of evidence suggesting that use of hMG may increase live birth rates,<sup>357</sup> many clinicians favor combined stimulation with FSH and hMG over stimulation with FSH alone.

The response to stimulation is monitored with serial measurements of serum estradiol and transvaginal ultrasonography. The first estradiol level usually is obtained after 3–5 days of stimulation to determine whether the chosen dose of gonadotropins requires adjustment. Thereafter, serum estradiol concentrations and sonography are obtained every 1–3 days, based on the quality of the response and the need to evaluate the impact of any further adjustments in the dose of gonadotropin treatment. In general, stimulation continues until at least two follicles measure 17–18 mm in mean diameter, when others typically measure 14–16 mm and the serum estradiol concentration reflects the overall size and maturity of the cohort. Most women require a total of 7–12 days of stimulation. It is important to emphasize that these parameters only approximate the

goals of stimulation. In clinical practice, follicle measurements vary among observers and estradiol assays vary in their performance characteristics.<sup>358</sup> Ultimately, each program must empirically establish its own thresholds, based on its own experience.

The endometrium is monitored during stimulation by measuring the endometrial thickness or “stripe” (the sum thickness of the two layers, measured in the midsagittal plane). Numerous studies have confirmed the prognostic value of endometrial thickness and pattern in ART cycles; however, the predictive value is modest. Many have suggested that results are best when endometrial thickness measures 8–9 mm or greater or appears “trilaminar” and poor when the endometrium is less than 6–7 mm in thickness or appears homogeneous on the day of hCG administration.<sup>359,360,361,362,363,364,365,366</sup> However, numerous others have failed to observe any absolute correlation between endometrial thickness or appearance and outcomes.<sup>367,368,369,370,371,372,373,374,375,376,377,378,379</sup> Some have suggested that excessive endometrial growth (>14 mm) also is a poor prognostic indicator,<sup>380,381</sup> but that too has been refuted.<sup>382,383</sup> Overall, although measurements of endometrial growth are routine, their utility remains unclear. Probably, there is no threshold that completely precludes pregnancy and live birth.<sup>384,385</sup> Consequently, changes in stimulation regimens and cycle cancellations based on endometrial thickness or appearance alone are difficult to justify except in the extreme.<sup>386,387</sup>

When the cohort of ovarian follicles reaches maturity, hCG (5,000–10,000 IU) is administered to stimulate the final stages of follicular development. The equivalent dose of the recombinant form of hCG now available is 250 µg. A 2016 systematic review including 15 trials comparing recombinant and urinary hCG observed no differences in clinical outcomes.<sup>388</sup> Oocyte maturation can also be triggered with a single bolus of a GnRH agonist in cycles without pituitary down-regulation. GnRH agonist injection triggers an endogenous LH surge, which is accompanied by an endogenous FSH surge as in the natural cycle.<sup>389</sup> The LH surge triggered by a GnRH agonist bolus is shorter in duration than the endogenous LH surge, is inadequate to support corpora lutea, and is associated with lower implantation, pregnancy, and live birth rates than the conventional hCG trigger. Since the agonist trigger results in rapid luteolysis, it is either used alone as a means of preventing OHSS, or in combination with the hCG trigger, dubbed as “dual trigger” in order to possibly improve oocyte quality by mimicking the simultaneous LH and FSH surges in the natural cycle.<sup>389,390</sup> However, whether dual trigger improves IVF outcome is yet controversial.<sup>391,392,393,394,395,396,397,398,399,400</sup>

It is clear that increased progesterone levels on the day of ovulation trigger are associated with decreased pregnancy rates.<sup>401,402,403,404</sup> Progesterone elevation is more common among women with a high response to stimulation and the adverse effect of

elevated progesterone levels seem to vary across categories of ovarian response. Based on a large sized study, pregnancy rates seem to decline when serum progesterone level exceeds 1.5 ng/mL in women with  $\leq 4$  oocytes, after 1.75 ng/mL in normoresponders, and 2.25 ng/mL for women with a high response.<sup>404</sup> **Elective cryopreservation of embryos for transfer in a subsequent natural or artificial cycle should be considered in cycles with follicular phase progesterone elevation.**<sup>405</sup>

In 2015, 11% of stimulation cycles were cancelled before oocyte retrieval, most for lack of adequate response, and some for excessive response.<sup>5,406</sup> When the ovaries become grossly enlarged, containing large numbers of follicles of all sizes, and serum estradiol concentrations are markedly elevated ( $>5,000$  pg/mL), the risk for OHSS increases substantially.<sup>407,408,409</sup> Options to decrease the risk of OHSS in “high responders” include all of the following:

- Cycle cancellation
- Administering a dopamine agonist for up to 7 days after the trigger
- “Coasting,” in which GnRH analogue treatment continues but without further gonadotropin stimulation for 1–3 days, triggering oocyte maturation after estradiol levels moderate
- In GnRH antagonist stimulation cycles, administering a GnRH agonist to trigger ovulation with or without a small dose of hCG, depending on the magnitude of ovarian response, for oocyte maturation
- Proceeding with oocyte retrieval and fertilization but freezing all embryos in lieu of transfer
- Delaying transfer until 5 days after retrieval while observing for clinical signs and symptoms of developing OHSS
- Administration of daily GnRH antagonist for a few days after egg collection, in order to induce rapid demise of corpora lutea by decreasing endogenous LH levels

With the current cryosurvival rates attained using embryo vitrification, there is little point in proceeding with fresh embryo transfer in women with high ovarian response. First and foremost, if pregnancy occurs, endogenous hCG can stimulate corpora lutea and induce the more severe “late OHSS”; secondly, endometrial receptivity is decreased in such hyperstimulated cycles leading to lower live birth rates.<sup>406,410,411</sup> Importantly, two or more of the above mentioned interventions can be combined for maximal prevention, especially when fresh embryo transfer is omitted.<sup>412</sup> Introduction of GnRH agonist trigger in GnRH antagonist cycles has almost provided OHSS-free practice; thus, GnRH antagonist stimulation (discussed below) should be the protocol of choice in anticipated high responders. However, no strategy ensures complete prevention of severe OHSS, and careful stimulation is always prudent.

The challenges presented by “poor responders” are far greater. Poor responders include women who develop few follicles (<3–5) despite high doses of gonadotropin stimulation or have relatively low peak estradiol levels (<500–1,000 pg/mL). A variety of definitions have been used to define poor response to stimulation. The European Society of Human Reproduction and Embryology published the Bologna criteria to define “poor ovarian response” in a standard and reproducible manner.<sup>413</sup> The Bologna Criteria includes age, ovarian reserve tests, and response to a prior stimulation cycle. As such, women with different characteristics can be defined as anticipated poor responders; however, whether these different subsets have similar prognosis is controversial, and the Bologna criteria have not gained wide acceptance.<sup>414,415,416</sup> Regardless, the prognosis is relatively poor for such women,<sup>145,351,417,418</sup> and the important decision centers on whether to attempt stimulation again using a different or more aggressive treatment regimen.<sup>419</sup> Some of the more commonly employed options include the following:

- The long protocol, beginning with higher doses of gonadotropin stimulation, if the patient was given submaximal dose in the index cycle
- Decreasing the doses of GnRH agonist or discontinuing agonist treatment immediately before or soon after gonadotropin stimulation begins
- A short follicular phase GnRH agonist treatment regimen using a standard or microdose “flare” protocol (described below)
- Using a GnRH antagonist (described below) instead of a long-acting agonist

**Different aspects of stimulation have been modified with the intention to increase the number and quality of eggs obtained for ART in poor responders. Suppression of the LH surge with a GnRH antagonist or short GnRH agonist flare protocol, such as microdose flare (described below), and stimulation with daily high-dose gonadotropins are appropriate first choices, and there is a strong need for well-designed RCTs investigating effects of addition of LH activity, estradiol priming, transdermal testosterone administration, and growth hormone supplementation.<sup>356</sup> High doses of gonadotropins may generate a somewhat more vigorous follicular response, but doses greater than 300 IU daily generally have no additional benefit. Given the lack of high-quality evidence showing effectiveness of one approach over another, other factors such as duration of stimulation, total gonadotropin consumption and cost of medication, patient friendliness, and possible side effect profiles must be considered in tailoring the stimulation protocol according to each individual’s needs and desires.**

# GnRH Agonist “Flare” Gonadotropin Stimulation Protocol

The “short” or “flare” protocol is an alternative stimulation regimen designed to exploit both the brief initial agonistic phase of response to a GnRH agonist and the suppression that results from longer-term treatment.<sup>420,421</sup> In a typical standard short protocol, leuprolide acetate (1.0 mg daily) is administered on cycle days 2–4, continuing thereafter at a reduced dose (0.5 mg daily), and gonadotropin stimulation begins on cycle day 3. Later adjustments in the dose of gonadotropin stimulation, if needed, are based on response, and indications for trigger are the same as in the long protocol (described above).

Decreased scheduling flexibility is a distinct disadvantage of the flare protocol, unless the onset of menses is controlled by preliminary treatment with an OC or estrogen. The regimen also can result in a significant increase in serum progesterone and androgen levels, presumably resulting from late corpus luteum rescue,<sup>422,423</sup> which may adversely affect oocyte quality and fertilization and pregnancy rates.<sup>424,425,426</sup>

The “OC microdose GnRH agonist flare” stimulation regimen is a variation of the standard short protocol involving 14–21 days of preliminary ovarian suppression with an OC (one pill daily), followed by microdose leuprolide treatment (40 µg twice daily) beginning 3 days after discontinuation of OC treatment and high-dose gonadotropin stimulation starting on day 3 of leuprolide therapy. Indications for later gonadotropin dose adjustments and trigger are the same as in other stimulation regimens. Its primary advantage over the standard short protocol is that it does not induce any increases in serum progesterone or androgen concentrations,<sup>427</sup> possibly because the doses of GnRH agonist administered are much lower, but likely also because preliminary OC treatment all but eliminates the possibility there may be a corpus luteum left to respond.<sup>428,429</sup>

Individual trials comparing stimulation protocols in women with poor response, as well as meta-analyses reported conflicting results.<sup>351,430,431</sup> While the long protocol takes longer and requires higher total gonadotropin consumption, whether it provides more or better quality oocytes is controversial, despite better synchronization of follicular cohort.<sup>351,356,430</sup> Given the absence of any clear benefit with regard to the number of oocytes collected or pregnancy rates, and a clear disadvantage with regard to gonadotropin consumption, the long protocol should not be the first choice for DOR, with the possible exception of patients with substantial asynchronous follicle development in repeated cycles.<sup>356</sup> Short GnRHa protocols seem to provide significantly higher number of oocytes, albeit as small as 0.5 oocytes more on average, with similar gonadotropin consumption compared to GnRH antagonist protocols.<sup>356</sup>

Hence, the preference between the two remains personal, taking into consideration the number of injections required and cost of medication.

# GnRH Antagonist Gonadotropin Stimulation Protocol

The introduction of GnRH antagonists into clinical practice provided another option for ovarian stimulation in ART. In contrast to the long-acting agonists, which first stimulate and later inhibit pituitary gonadotropin secretion by desensitizing gonadotrophs to GnRH via receptor down-regulation, the antagonists block the GnRH receptor in a dose-dependent competitive fashion and have no similar flare effect<sup>432,433</sup>; gonadotropin suppression is almost immediate.

GnRH antagonists offer several potential advantages over agonists. First, the duration of treatment for an antagonist is substantially shorter than for an agonist. Since its only purpose is to prevent a premature endogenous LH surge and its effects are immediate, antagonist treatment can be postponed until later in follicular development (after 5–6 days of gonadotropin stimulation), after estradiol levels are already elevated, thereby eliminating the estrogen deficiency symptoms that may emerge in women treated with an agonist.<sup>434</sup> Second, because any suppressive effects that agonists may exert on the ovarian response to gonadotropin stimulation also are eliminated, the total dose and duration of gonadotropin stimulation required is decreased.<sup>434,435</sup> For the same reason, GnRH antagonist stimulation protocols may benefit women who are poor responders when treated with a standard long protocol.<sup>356,434,436</sup> Third, by eliminating the flare effect of agonists, GnRH antagonists avoid the risk of stimulating development of a follicular cyst. Finally, the risk of severe OHSS associated with use of antagonists also appears lower than with agonists.<sup>437,438,439,440</sup> The risk of OHSS can be further diminished with the use of a GnRH agonist trigger in GnRH antagonist stimulated cycles, an option that is not available when GnRH agonists are used for pituitary suppression.

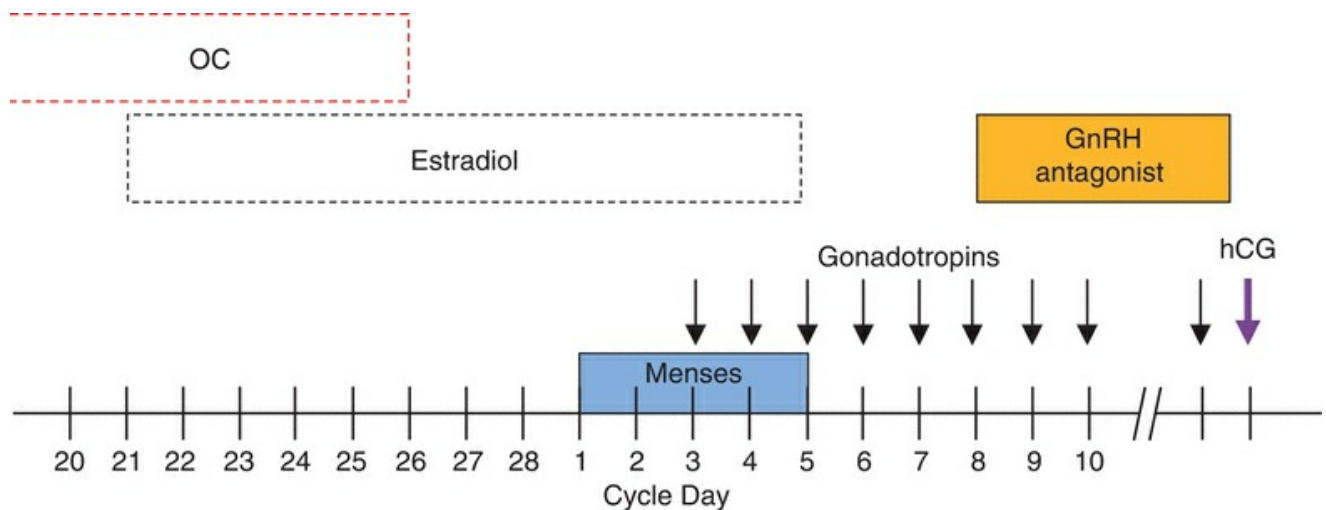
GnRH antagonists have some potential disadvantages. When administered in small daily doses, strict compliance with the prescribed treatment regimen is essential.<sup>434</sup> Antagonists suppress endogenous gonadotropin secretion more completely than agonists. While initial studies suggested modestly lower pregnancy rates in antagonist treatment cycles than in cycles using agonists in the long protocol, this could have been due to patient selection or lack of experience with the use of antagonists, and recent evidence suggests similar live birth and pregnancy rates in GnRH antagonist cycles.<sup>441,442,443</sup> **Overall, due to their ease of use and comparable outcomes, antagonist protocols are used more commonly than long GnRH agonist protocols worldwide.**

The two GnRH antagonists available for clinical use, ganirelix and cetrorelix, are



equally potent and effective. For both, the minimum effective dose to prevent a premature LH surge is 0.25 mg daily, administered subcutaneously.<sup>347,444</sup> The treatment protocol may be fixed and begin after 5–6 days of gonadotropin stimulation<sup>347,444,445</sup> or tailored to the response of the individual, starting treatment when the lead follicle reaches approximately 13–14 mm in diameter.<sup>446,447</sup> The individualized treatment regimen generally requires fewer total doses and may yield better overall results.<sup>446</sup> Alternatively, a single larger dose of cetrorelix (3.0 mg) will effectively prevent an LH surge for 96 hours. If given on day 6–7 of stimulation, the interval of effective suppression will encompass the day of hCG administration in most women (75–90%); the remainder may receive additional daily doses (0.25 mg) as needed, ending on the day of hCG treatment.<sup>448,449,450</sup> The single-dose antagonist treatment regimen also can be withheld until the lead follicle reaches 13–14 mm in diameter.<sup>451</sup>

A common variation of the antagonist stimulation regimen uses preliminary treatment with an OC to control the onset of menses, typically ending at least 5 days before the scheduled start, which also may help to synchronize the follicular cohort before stimulation begins. However, OC priming is associated with longer duration of stimulation and higher gonadotropin consumption without an increase in cumulus oocyte complexes and a significant decrease in ongoing pregnancy and live birth rates.<sup>452,453</sup> Based on a single retrospective study, micronized estradiol (2 mg three times daily, administered orally) starting from the 2nd or 3rd day of menstrual cycle can be used to schedule the start of gonadotropins in GnRH antagonist cycles. Estradiol suppresses endogenous FSH halting follicular growth and is stopped on the day of scheduled gonadotropin start.<sup>454</sup> Follicular phase estradiol scheduling does not seem to increase gonadotropin consumption or hamper clinical outcome. Another variation advocated for poor responders uses micronized estradiol (2 mg twice daily, administered orally, beginning on day 21 of the preceding cycle) to suppress FSH during the late luteal phase for the same purpose, ending on the day before gonadotropin stimulation begins<sup>451,455</sup> or continuing through the first 3 days of gonadotropin stimulation.<sup>418</sup> The improved follicular dynamics observed are similar to those achieved by down-regulation with a GnRH agonist in the long protocol. The rebound increase in endogenous FSH levels that follows the discontinuation of estradiol treatment also may synergize with exogenous gonadotropins to promote multifollicular development (**Figure 28.6**).<sup>456,457</sup>



**FIGURE 28.6**

Women with PCOS characteristically exhibit high tonic LH secretion and are predisposed to premature LH surges when treated with standard ovulation induction regimens. Women with PCOS also are at increased risk for developing OHSS when aggressively stimulated with exogenous gonadotropins. Whereas both GnRH agonists and antagonists can suppress elevated circulating LH concentrations, the smaller follicular cohorts observed in antagonist cycles may help to reduce the risk of OHSS in women with PCOS who tend to be high responders. **The use of antagonists, rather than agonists, provides the opportunity to use an agonist instead of hCG to induce final oocyte maturation, thereby possibly further decreasing the risk of OHSS.**<sup>458</sup> Whereas a single bolus injection of an agonist (leuprolide 0.5 mg, triptorelin 0.2 mg) triggers a physiologic LH surge that lasts less than 24 hours, hCG levels remain elevated for several days and stimulate markedly higher estradiol and progesterone concentrations.<sup>459</sup>

The antagonist treatment regimens currently in use have potential disadvantages for women with PCOS. Their tonically elevated LH levels will remain high until antagonist treatment begins. Consequently, LH levels may rise prematurely, particularly if antagonist treatment is withheld until the lead follicle reaches 14 mm or more. Moreover, evidence indicates that increased LH exposure during early follicular development may be detrimental and predispose to lower pregnancy rates.<sup>460,461,462,463</sup> In theory, pretreatment with an OC might prove quite useful by suppressing LH and androgen levels before stimulation begins, decreasing exposure during early follicular development and the risk of rising LH levels before antagonist treatment starts. Preliminary OC suppression and later antagonist treatment may help to limit the follicular response to gonadotropin stimulation while preserving the option to use an agonist to trigger final oocyte maturation. However, OC pretreatment can be associated

with lower pregnancy rates if a fresh transfer is attempted.<sup>452,453</sup>

Antagonist stimulation protocols are advocated for poor responders, primarily because they avoid the suppressive effects that agonists can have on follicular response and can prevent the premature LH surges observed commonly in women stimulated with gonadotropins alone.<sup>413</sup> However, evidence is insufficient to indicate they yield results consistently better than other stimulation regimens.<sup>351,464</sup>

# GnRH Agonist Triggering of Oocyte Maturation

The first to report of GnRHa trigger in human IVF was in 1990 and involved 18 women, who underwent ovarian stimulation without pituitary suppression and received GnRHa or hCG as the trigger to induce final follicular maturation. Similar numbers of oocytes were collected; fertilization rate, embryo development rates, and pregnancy rates were also similar with GnRHa as compared to hCG triggers.<sup>465</sup> However, soon after this report, pituitary suppression with GnRHa to prevent the LH rise prior to egg retrieval became the norm in ART and the use of GnRHa trigger was abandoned until the introduction of GnRH antagonists into IVF practice.

When reintroduced, GnRHa trigger was initially used to prevent OHSS in GnRH antagonist cycles.<sup>466</sup> The luteinizing hormone (LH) surge following GnRHa trigger lasts even shorter than natural LH surge. In addition, the half-life of LH is much shorter than that of hCG.<sup>389,459</sup> These two characteristics serve to decrease the luteinizing stimulus on the granulosa cells, limiting the production of vascular endothelial growth factor, which is responsible for increased vascular permeability, the hallmark of OHSS.<sup>467,468,469</sup>

GnRHa trigger is associated with decreased size and number of corpora lutea, decreased expression of steroidogenic enzymes, and consequently lower estradiol and progesterone production during the luteal phase.<sup>470,471</sup> Initial clinical trials confirmed findings of similar oocyte yield and embryo quality following GnRHa trigger. However, significantly lower pregnancy rates accompanied by higher rate of pregnancy loss compared to conventional hCG trigger were alarming.<sup>459,472,473</sup> A randomized trial demonstrated similar implantation and pregnancy rates in oocyte recipients from donors triggered with hCG or GnRHa, suggesting the adverse effect being on the endometrium rather than the oocytes.<sup>474</sup> Two uncontrolled case series of oocyte and embryo freezing following GnRHa trigger reported cryosurvival, implantation, and pregnancy rates within expected range of hCG trigger. Altogether, these data provided convincing evidence for a suboptimal luteal phase impacting on birth rates following GnRHa trigger.<sup>475,476</sup>

Initial studies of rescuing luteal phase by “intensive luteal support” through administration of high doses of exogenous progesterone and estrogen yielded contradictory results.<sup>477,478</sup> High endogenous LH level is an important factor contributing to the observed success of intensive luteal support in some studies.<sup>479</sup> The magnitude of the LH peak induced with GnRHa bolus, which is related with early follicular phase serum LH levels, is a determinant of pregnancy rates following GnRHa trigger and intensive luteal support.<sup>480</sup> Overall, intensive luteal support can be a viable

option for women with PCOS, the very same patients who comprise the highest risk group for OHSS following hCG injection.

Rescuing the luteal phase with a small dose of hCG after GnRHa trigger is another option. A series of randomized controlled trials suggested equivalent ongoing pregnancy rates with GnRHa trigger followed by 1,500 IU hCG injection 35 hours later and luteal phase support with vaginal progesterone and oral estradiol.<sup>472,481,482,483</sup> Not only luteal phase serum estradiol and progesterone levels but also ongoing pregnancy rates were statistically similar to hCG trigger, despite a trend toward lower rates with GnRHa + 1,500 hCG. The success of hCG rescue in maintaining pregnancy rates were confirmed in several uncontrolled case series, and it was suggested that severe early OHSS could be successfully prevented with this method.<sup>484,485</sup> However, several reports of severe early OHSS following GnRHa trigger with or even without any hCG rescue proved it an elusive goal to completely prevent OHSS.<sup>486,487,488</sup> Therefore, it seems prudent to completely avoid hCG support in women with predicted high ovarian response, although precise markers of ovarian reserve and threshold levels remain to be determined.

Another setting where GnRHa triggering could prove useful is oocyte collection cycles for the purpose of fertility preservation in patients with hormone sensitive tumors, such as breast cancer. The rapid decline in serum estradiol and progesterone levels following GnRHa trigger limits tumor exposure to these hormones.<sup>489</sup> Clearly, GnRHa trigger should be the norm in fertility preservation cycles, as it does not affect oocyte yield or quality.

Overall, GnRHa trigger enables collection of similar number of oocytes as with the conventional hCG trigger. It is the ovulation trigger of choice for women at risk of OHSS and in fertility preservation cycles. The decision to proceed with a fresh or frozen transfer should be individualized, as well as the method of luteal phase rescue in fresh transfers.

# UNCONVENTIONAL STIMULATION

# OVARIAN

Traditionally, ovarian stimulation is started in the early follicular phase. The rationale for this timing includes stimulation of a synchronous cohort of antral follicles recruited during the luteofollicular transition and inducing timely endometrial development to synchronize blastocyst development with the implantation window. However, synchronizing endometrial and follicular development is not required if the aim of the cycle is oocyte or embryo cryopreservation without a fresh embryo transfer. This is particularly relevant when time is a constraint, such as in women with malignancy awaiting gonadotoxic chemotherapy. Increasing evidence suggests that multiple waves of antral follicles develop during one menstrual cycle, challenging the concept of a single recruitment episode during the follicular phase.<sup>490</sup> Among different theories of follicular recruitment, the wave theory forms the basis of ovarian stimulation during the luteal phase. While the dominant follicle formed in the final wave of the interovulatory interval reaches ovulation, the preceding waves are anovulatory.<sup>490</sup> However, follicles that are in the anovulatory waves that precede and follow the ovulatory wave can reach ovulatory stage if exposed to FSH stimulation. Based on this concept, ovarian stimulation may be started at any time during the menstrual cycle; the so-called random start ovarian stimulation.<sup>491</sup>

Initially, the random start stimulation was used for fertility preservation in women with cancer.<sup>492,493</sup> More recently, encouraging results have been reported with luteal phase start ovarian stimulation in women with normal or poor ovarian reserve.<sup>494,495</sup> Stimulating the ovaries twice during a single menstrual cycle has been done as an alternative strategy that aims rapid accumulation of embryos in poor responders. The initial stimulation is commenced in the follicular phase with a GnRH antagonist protocol, usually followed by a GnRH agonist trigger, and another cycle of stimulation is initiated after egg collection.<sup>494</sup> Already elevated progesterone levels from the corpora lutea prevent the endogenous LH surge, and the luteal phase stimulation can be completed even without using GnRH antagonist in many cases. A 2016 meta-analysis reports that the luteal phase stimulation takes significantly longer (on average 1.5 days), despite consumption of more gonadotropins (on average 817 IU), but may yield a higher number of mature oocytes.<sup>496,497</sup> Based on limited data, oocytes collected in the luteal phase develop into blastocyst at a similar rate with oocytes from follicular phase, euploidy rates of these blastocysts are similar, and, when transferred in an artificial cycle, they yield similar pregnancy rates.<sup>497,498</sup> Limited data on obstetric outcome of and congenital anomalies in pregnancies derived from frozen-thawed transfer of embryos derived from luteal phase stimulation ovaries suggest similar results with follicular

phase oocyte retrievals.<sup>499</sup>

# OOCYTE RETRIEVAL

---

Oocyte retrieval is generally performed approximately 34–36 hours after hCG administration. Slightly longer intervals do not substantially increase the risk of ovulation or adversely affect oocyte quality, fertilization rates, or overall results in GnRH agonist down-regulated stimulation cycles,<sup>500,501,502,503</sup> but earlier retrievals yield fewer mature oocytes.<sup>504</sup>

Whereas oocyte retrieval once was performed via laparoscopy, transvaginal aspiration guided by ultrasonography under intravenous sedation is now the standard technique. Deep sedation (propofol) is most common, but most women tolerate the procedure very well with “conscious sedation” using short-acting narcotics (fentanyl) and benzodiazepines (midazolam), administered in small doses, as needed. There is no compelling evidence to indicate any difference in patient satisfaction or outcomes.<sup>505</sup> Continuous monitoring by automated blood pressure recordings and pulse oximetry is essential to ensure that the proper plane of sedation is maintained and not exceeded. Specific reversal agents for narcotics (naloxone) and benzodiazepines (flumazenil) should be readily available.

Prophylactic antibiotic treatment (doxycycline 100 mg or cefoxitin 2 g), administered intravenously 30–60 minutes before retrieval is common but controversial because of the low incidence of infectious complications following retrieval (0.3–0.6%).<sup>506,507</sup> Alternatively, oral antibiotics may be started immediately following the procedure (tetracycline, doxycycline), reserving prophylactic intravenous antibiotics for women at increased risk for infection (history of pelvic inflammatory disease, endometrioma).

Antiseptics (povidone-iodine) are toxic to oocytes, and limited evidence suggests their use may be associated with lower pregnancy rates.<sup>508</sup> When used to prepare the vagina before retrieval, thorough irrigation with sterile saline should follow, but repeated irrigation with saline alone is generally sufficient to cleanse the vagina. The bladder can become distended as a result of intravenous fluid administration but can be drained immediately before retrieval; an indwelling catheter is unnecessary.

A vaginal probe (5–7 MHz) in a sterile plastic sheath with an attached needle guide is used to image the ovaries and to align the guide with the follicles in their largest diameter. A specially designed disposable 16- to 17-gauge needle is used to enter each follicle, in turn, and to aspirate the follicular fluid and oocytes. At the proper vacuum pressure (approximately 100 mm Hg), the follicle walls collapse but do not obstruct the needle lumen. Whereas some have observed that flushing and reaspiration of follicles using a double-lumen needle can increase oocyte yield,<sup>509</sup> the majority of evidence



shows similar oocyte yield, fertilization, and pregnancy rates while increasing operating time and analgesic requirements.<sup>510,511,512</sup> This holds true for even in women with few follicles.<sup>513</sup> As such follicular flushing seems unnecessary and has been largely abandoned. Efforts to minimize the arc swept by the needle within the ovary help to limit discomfort and ovarian trauma. In general, all follicles within the ovaries greater than 10 mm in diameter can be aspirated with no more than one to three separate entries on each side. Flushing the needle and attached tubing with media after each withdrawal helps to maximize oocyte yield. Abdominal pressure can sometimes stabilize a mobile ovary or move an ovary into a more convenient location for aspiration. Ovaries adherent to the posterior uterus often are more easily approached from the contralateral side but may be difficult to enter without traversing a portion of the uterus.<sup>514</sup> It may be more prudent to simply abandon some follicles, particularly when the number of oocytes already retrieved is sufficient.

The “empty follicle syndrome,” characterized by a failure to retrieve oocytes despite apparently normal multifollicular development, occurs in up to 0.5–1% of cycles.<sup>515,516,517</sup> The phenomenon can be observed when hCG is administered later than scheduled<sup>518</sup> or forgotten altogether<sup>516</sup> and might rarely result from reduced biologic activity in some lots of commercially prepared hCG.<sup>519,520,521</sup> The serum hCG concentration 36 hours after injection generally ranges between 100 and 300 IU/L.<sup>520</sup> Despite increasing use of recombinant hCG and agonist trigger, empty follicle syndrome occurs at similar rate.<sup>480,522</sup> In one series of women who received agonist trigger, all cases of empty follicle syndrome occurred in women with serum LH levels lesser than 15 IU/L measured 8–12 hours after agonist administration.<sup>480</sup>

Serious complications of oocyte retrieval are uncommon. Limited vaginal hemorrhage from a puncture site is relatively common (8%) and usually can be controlled with a brief interval of direct pressure but may require a suture.<sup>507</sup> Acute hemorrhage from the ovary and hemorrhage or hematomas resulting from injury to the uterine, ovarian, or iliac vessels are rare (0.04–0.07%).<sup>507</sup> The incidence of postoperative pelvic infections is quite low even without prophylactic antibiotic treatment (0.3–0.6%), and, of those, almost half present as tuboovarian abscesses, 1–6 weeks after retrieval.<sup>77,506,507</sup> Women with ovarian endometriomas and those with past history of salpingitis are at highest risk.<sup>73,74,75,77,523,524,525</sup> Higher number of oocytes retrieved, longer duration of the procedure and the mean time per oocyte retrieved, inexperience of the surgeon, and younger age with lesser BMI are other risk factors.<sup>526</sup> Other rare reported complications include the rupture of a dermoid cyst,<sup>527</sup> laceration of a sacral vein,<sup>528</sup> and lumbosacral osteomyelitis.<sup>529,530</sup>

# Oocyte Maturation

Up to 20–30% of retrieved oocytes may be immature at the time of retrieval, reflecting the varying size and maturity of follicles in the cohort at the time hCG is administered. An accurate assessment of oocyte maturity is important to the timing of fertilization, even more so when ICSI is to be performed.

Like the LH surge in natural cycles, hCG triggers the resumption of meiosis in primary oocytes previously arrested at prophase I of the first meiotic division. Oocyte maturity generally can be judged by the expansion of the cumulus mass, radiance of the corona cells, the size and cohesiveness of granulosa cells, and the shape and color of the oocyte. When the cumulus mass is removed, as it is in preparation for ICSI, the oocyte can be further evaluated according to the presence or absence of the first polar body and germinal vesicle (nuclear membrane).

A mature (metaphase II) oocyte has extruded the first polar body and is in the resting phase of meiosis II. The cumulus cells are typically expanded and luteinized and the corona radiata exhibits a sunburst pattern. A metaphase I oocyte of intermediate maturity has no polar body and denser cumulus cells, but the germinal vesicle and nucleolus have faded. Metaphase I oocytes require additional time in culture before fertilization and must be examined periodically to document extrusion of the first polar body. A prophase I oocyte is grossly immature and exhibits a compact corona containing relatively few cumulus cells and a prominent germinal vesicle (GV) and nucleolus; dissolution of the germinal vesicle signals the resumption of meiosis I.

## In Vitro Maturation

Human oocytes reach full size (100–200  $\mu\text{m}$ ) during the early antral stage of follicular development. The ability of an oocyte to resume and complete meiosis relates to follicular diameter.<sup>531,532,533</sup> Although immature oocytes collected from small antral follicles can mature with time in culture (the majority within 46–48 hours), even those that reach meiosis II do not necessarily acquire developmental competence, which requires synchronous maturation of both the nucleus and cytoplasm. Consequently, although they frequently fertilize, immature oocytes yield embryos that often develop poorly and exhibit low implantation potential.<sup>534,535</sup> Nuclear maturation involves germinal vesicle breakdown, normally induced by the LH surge, followed by resumption of meiosis and, finally, extrusion of the first polar body. Cytoplasmic maturation is more difficult to define but involves a number of factors that prepare the cytoplasm for fertilization and subsequent embryonic development.<sup>536</sup> Epigenetic processes are involved in both nuclear and cytoplasmic maturation and influence development after fertilization.<sup>537,538</sup>

Despite the existence of different opinions among clinicians regarding what constitutes an in vitro maturation (IVM) cycle, technically, the term IVM describes the maturation of immature oocytes in culture after their retrieval.<sup>539</sup> The conventional definition implies collection of GV oocytes from small follicles **not** exposed to exogenous LH or hCG in vivo. In efforts to improve the relatively low efficiency of classical IVM, “follicular priming” has been developed.<sup>540,541,542</sup> One method involves FSH treatment for 3–6 days, followed by retrieval on cycle day 9–10. Another involves a single injection of hCG (10,000 IU), administered when the largest follicle reaches 10–12 mm in size and 36 hours before retrieval. A third method combines the two techniques, involving sequential treatment with FSH and hCG before oocyte retrieval.

Numerous studies have explored methods for IVM using oocytes obtained from normal women<sup>543,544,545,546,547,548</sup> and from women with PCOS.<sup>543,544,548,549,550,551,552,553,554,555</sup> Studies examining the effects of follicular priming in vivo have yielded inconsistent results, but embryos derived from primed oocytes generally have yielded higher implantation and pregnancy rates than those derived from oocytes collected from unstimulated antral follicles.<sup>551,553,555</sup> In one large trial examining the efficiency of IVM in women with normal ovaries, 400 women were randomly allocated to receive no priming or priming with hCG, FSH, or FSH followed by hCG.<sup>556</sup> The overall maturation rate and total number of available metaphase II oocytes were significantly higher in the groups receiving hCG than in those not receiving hCG. The overall clinical pregnancy rate per transfer was 18.3% and the implantation rate was 10.6%. Among the groups, the clinical pregnancy rate was higher in the group receiving both FSH and hCG priming (30%) than in all others.<sup>556</sup> However, a 2016 meta-analysis shows that hCG priming alone does not seem to improve live birth rates in IVM cycles.<sup>557</sup>

The best timing and method for efficient retrieval of immature oocytes from small follicles (<10 mm in diameter) have not been established.<sup>553,558,559</sup> Aspiration of follicles greater than 13 mm in size generally has yielded fewer oocytes, possibly because such follicles are already atretic.<sup>560</sup> A variety of aspiration vacuum pressures (80–300 mm Hg) and needles (16–20 gauge) have been described.<sup>558,561</sup> Whereas evidence is insufficient to warrant recommendation of any one method, extremely high vacuum pressures appear to adversely affect oocyte development in vitro.<sup>562</sup> The culture media composition that best supports IVM and the best method for fertilization of oocytes subjected to IVM also remain to be established; ICSI has achieved similar or higher fertilization rates, and embryos derived from oocytes fertilized by conventional methods have exhibited similar or higher implantation rates and yielded higher clinical pregnancy rates,<sup>544,563</sup> suggesting that ICSI is not required.

Although the clinical pregnancy rates achieved in IVM trials have been reasonably good, they do not approach those of standard IVF and have been achieved by transfer of a larger number of embryos. Implantation rates for embryos derived from IVM oocytes (5–22%) also are lower than those expected in similar women (age <35 years) receiving treatment with conventional IVF (34%).<sup>564</sup> Limited number of studies report similar aneuploidy rates of embryos derived from in vivo matured and in vitro matured oocytes; therefore, factors other than aneuploidy seem to be responsible for lower efficiency of IVM.<sup>565,566</sup> A retrospective study including 178 cycles in 121 women compared live birth rates following fresh and frozen embryo transfers (FETs) in IVM and IVF cycles. While live birth rate was significantly lower following fresh blastocyst transfers in IVM cycles, live birth rate was similar between the two groups following frozen blastocyst transfers.<sup>567</sup> This suggests that embryo-endometrium asynchrony can be a factor limiting effectiveness of IVM. Although the number of children derived from oocytes subjected to IVM is still quite small, preventing confident conclusions, the incidence of malformations and developmental abnormalities has thus far not differed from those in children resulting from traditional IVF or ICSI.<sup>568</sup>

**In summary, the results achieved thus far with IVM after follicular priming in vivo suggest the methods have clinical promise. However, numerous questions must be answered before IVM can be recommended for wider clinical application.**<sup>569</sup> Women with PCOS having large numbers of antral follicles and greatest risk for developing OHSS represent a population that could benefit from IVM, because purposeful retrieval of immature oocytes would require fewer days of gonadotropin stimulation. However, the widespread introduction of agonist trigger has limited the risks and hence the indication for IVM. Women with cancer represent another group that can benefit from such treatment; many require immediate treatment that does afford them the time to pursue established methods of fertility preservation, which require ovarian stimulation, oocyte retrieval, and oocyte or embryo cryopreservation.

# FERTILIZATION

---

Fertilization can be achieved by conventional microinsemination or by ICSI when there is a known or suspected male factor and concern for poor or failed fertilization. In fact, male factor infertility is the one most common diagnosis among couples who undergo IVF. In the U.S. national ART summary for 2015, 35% of all cycles were performed for male factor indications, and a male factor was one of multiple infertility factors in another 18% of cycles.<sup>5</sup>

A semen sample should be obtained by masturbation immediately before or after retrieval. The two methods most commonly used for sperm preparation before fertilization, the “swim-up” procedure and density gradient centrifugation, are described in detail in [Chapter 26](#). Whereas both methods can successfully isolate a population of highly motile sperm for insemination, density gradient centrifugation also appears to select sperm with normal morphology and is widely regarded as the better choice when semen parameters are abnormal.<sup>570,571,572,573</sup> The isolated sperm are then incubated in media supplemented with a high concentration of protein for 0.5–4.0 hours to achieve capacitation. A combination of both methods, density gradient centrifugation followed by swim up, is reported to decrease the number of sperm with ultrastructural abnormalities in the head and tail.<sup>574</sup> Recently, microfluidic chips have been introduced for sorting motile sperm from unprocessed semen sample. While some studies show decreased DNA fragmentation in sperm selected by microfluidic chips, convincing evidence demonstrating improved live birth rates with their use is lacking.<sup>575,576,577</sup>

In general, each oocyte is incubated with 50–100 thousand motile sperm for an interval of 12–18 hours at 37°C in 5–20% oxygen and 4–7% carbon dioxide in air at 94–98% relative humidity. The acrosome reaction, which enables sperm to penetrate the zona pellucida, is initiated by contact between the sperm and the zona. In turn, sperm penetration triggers the cortical reaction, which involves exocytosis of cortical granules from the ooplasm and renders the zona pellucida relatively refractory to penetration by more than a single sperm (block to polyspermy). Conventional IVF typically achieves fertilization rates ranging between 50% and 70%.

Sperm penetration also activates the oocyte and stimulates the second meiotic division, resulting in segregation of chromatids between the fertilized oocyte and the second polar body. Oocytes are evaluated for evidence of fertilization at approximately 18 hours after insemination. A normally fertilized oocyte exhibits two distinct pronuclei, one derived from the oocyte and the other from the sperm, and two polar bodies in the perivitelline space. The zygotes must be carefully inspected for the presence of extra pronuclei because polyploid embryos may cleave normally and go unrecognized at later stages of development. Polyploidy can be observed in up to 5–10% of embryos overall

but is far more prevalent in immature oocytes (up to 30%) than in mature oocytes (1–2%).<sup>578,579</sup> Besides polyspermy, polyploidy may result from digyny (fertilization of a diploid oocyte), due to meiotic spindle errors or failure to extrude a polar body, which are more commonly associated with immature, aging, or postmature oocytes.<sup>580,581</sup> The fertilization process requires approximately 24 hours and ends with the first mitotic division (cleavage).

Past failure of fertilization or severe male factor infertility requires ICSI, which yields pregnancy rates in couples with male factor infertility that compare favorably with those in couples without a male factor.<sup>582</sup> In the absence of a male factor, ICSI offers no clinical advantage over conventional IVF<sup>583,584</sup>; in fact, evidence suggests that standard IVF yields higher implantation and clinical pregnancy rates.<sup>5,583</sup>

When there is no ejaculate (aspermia) or only rare or no sperm (azoospermia) in the ejaculate, a variety of methods can be used to retrieve sperm for fertilization. Donor sperm also can be used, by design or as a contingency should efforts to retrieve sperm on the day of oocyte retrieval fail. Men with ejaculatory failure have either no ejaculate or retrograde ejaculation. Ejaculatory failure may result from neurologic dysfunction or injury to the sympathetic outflow tracts that control emission and ejaculation (spinal cord injury, diabetes mellitus, multiple sclerosis, retroperitoneal surgery) or can be psychogenic in origin. Azoospermia may relate to ductal obstruction (obstructive azoospermia) or result from Sertoli cell-only syndrome, maturation arrest, or hypospermatogenesis (nonobstructive azoospermia). The diagnostic evaluation for aspermic and azoospermic men is described in detail in [Chapter 26](#).

## Sperm Retrieval Techniques

In the past, men with nonobstructive azoospermia were considered sterile and untreatable by any means other than the use of donor sperm. However, testis biopsy specimens in such men often demonstrate sperm,<sup>585</sup> suggesting low-level production of sperm that do not survive epididymal transit to reach the ejaculate.<sup>586</sup> **Whereas conventional wisdom was that sperm must traverse the male reproductive tract to acquire the ability to fertilize an oocyte, success with ICSI using epididymal or testicular sperm has demonstrated otherwise.** Even grossly immature sperm (round spermatid nuclear injection; ROSNI) have been used to achieve fertilization, albeit with limited success.<sup>587</sup>

**It is important to emphasize again that genetic evaluation and counseling are indicated for men with severe seminal abnormalities before their sperm are used for ICSI.** Men with congenital bilateral absence of the vas deferens (CBAVD) or less severe forms of vasal aplasia, and their female partners, should be screened for cystic fibrosis gene mutations before any attempts at pregnancy via ART to determine the risk for transmitting cystic fibrosis or CBAVD to offspring.<sup>588,589,590</sup> Men with nonobstructive azoospermia or severe oligospermia (<5 million/mL) should be offered karyotyping and screening for Y chromosome microdeletions.<sup>590</sup>

## Sperm Recovery in Men with Retrograde Ejaculation

Men with documented retrograde ejaculation may be treated with sympathomimetics directed at control of the internal sphincter (imipramine 25 mg twice daily or 50 mg at bedtime, pseudoephedrine 60 mg, ephedrine 25–50 mg four times daily, phenylpropanolamine 50–75 mg twice daily). When medical treatment proves unsuccessful, sperm can be recovered directly from the bladder after masturbation; best results are achieved when urine pH and osmolality (300–380 mOsm/L) are carefully controlled by alkalinizing the urine (sodium bicarbonate 650 mg four times daily, beginning 1–2 days before collection) and controlling fluid intake.<sup>591,592</sup> Alternatively, the bladder can be filled with buffered medium immediately before ejaculation.

## Vibratory Stimulation and Electroejaculation

In men with psychogenic ejaculatory failure or spinal cord injuries below the T6 level, vibratory stimulation often can succeed in producing an ejaculate. Rectal probe electrical stimulation (electroejaculation) is recommended for men who fail vibratory stimulation and those with previous retroperitoneal surgery.<sup>593,594</sup> Induced ejaculations may be retrograde and further require the procedures described above. Because

electroejaculates frequently exhibit asthenospermia and teratospermia, ICSI is often necessary.

## **Epididymal Sperm Aspiration**

Sperm can be obtained by MESA at the time of vasoepididymostomy or as an isolated procedure in men with CBAVD or uncorrectable obstructions. The technique involves incision of an isolated dilated tubule, gradually moving more proximally, if necessary, until sperm are obtained.<sup>595,596</sup> Sperm are collected into a micropipette by capillary action with gentle compression of the testis and epididymis and flushed into a container with a small volume of IVF culture medium. Recovered sperm are cryopreserved in multiple aliquots for use in IVF cycles, if required.<sup>597</sup>

Percutaneous epididymal sperm aspiration (PESA) using a fine needle also has been used successfully to obtain sperm and achieve pregnancy,<sup>598,599</sup> but the technique is less reliable, the small quantities of sperm obtained are sometimes inadequate to allow cryopreservation, and the pregnancy rates achieved generally have been lower than with the open technique.

## **Testicular Sperm Extraction and Aspiration**

In men with nonobstructive azoospermia and those in whom epididymal sperm aspiration techniques fail or do not apply, sperm can be retrieved using any of three other techniques. Open microsurgical TESE yields the greatest number of sperm with potential for cryopreservation. Percutaneous core biopsy or aspiration of the testis has also been described but is most applicable in men with normal spermatogenesis and obstructive azoospermia.<sup>600,601</sup>

Using the preferred open microsurgical technique, sperm can be retrieved from the majority of men, even those with nonobstructive azoospermia. Magnification minimizes the risk of injury to the testicular blood supply, increases the probability of retrieving a blood-free biopsy specimen, and allows identification of larger caliber tubules that are more likely to yield sperm.<sup>602,603</sup> Normal pregnancies have been achieved even in those with congenital or acquired testicular failure,<sup>604</sup> postchemotherapy azoospermia,<sup>605</sup> and Klinefelter syndrome.<sup>606</sup>

In men with nonobstructive azoospermia, TESE is best performed on the day of or day before oocyte retrieval, when possible, and no earlier than approximately 6 months after any previous biopsy or TESE procedure, for several reasons. First, up to one-third of men with apparent nonobstructive azoospermia may exhibit sperm in their ejaculate on the day of planned retrieval and will not require TESE.<sup>607</sup> Second, sperm retrieved from men with nonobstructive azoospermia may not be motile or viable after



cryopreservation and thawing; ICSI using immotile sperm may yield worse results than when performed with fresh motile sperm.<sup>608</sup> Finally, the likelihood of successful retrieval of viable sperm for ICSI is significantly reduced when TESE is performed soon after a testis biopsy or previous TESE.<sup>608</sup> Matched donor sperm should be offered and available as backup, because TESE yields viable sperm in only about half of men with nonobstructive azoospermia.<sup>602,609,610</sup> When TESE cannot be performed near the time of oocyte retrieval, elective TESE can be performed and the recovered sperm cryopreserved; the risk of having no viable sperm after thaw is real but relatively low, and donor sperm can be used if needed.<sup>611,612,613</sup>

# Intracytoplasmic Sperm Injection

Assisted fertilization techniques were developed to circumvent the need for sperm to penetrate the zona pellucida. A variety of methods have been described, but the success of ICSI has rendered all others obsolete.<sup>614,615</sup> Earlier methods, including zona “drilling” (using a micropipette and acidified Tyrode solution or laser),<sup>616,617</sup> partial zona dissection (opening the zona with a microneedle),<sup>618</sup> and subzonal insertion or insemination (injection of sperm beneath the zona in the perivitelline space),<sup>619</sup> still required sperm to interact with the oolemma and did not prevent polyspermic fertilization, but ICSI solved those problems.<sup>620</sup>

In the ICSI procedure, a single selected sperm is first immobilized by compressing the sperm tail with an injection pipette (inner diameter 5–7  $\mu\text{m}$ ), then drawn into the pipette. The oocyte is stabilized with a holding pipette at the 9 o’clock position, usually with the polar body at the 6 or 12 o’clock position, and entered at the 3 o’clock position. The injection pipette pierces the zona and oolemma and the sperm is injected directly into the ooplasm. ICSI does not require sperm to undergo the acrosome reaction or to fuse with the oocyte membrane as occurs with natural fertilization. Instead, the mechanical disruption of the ooplasm and sperm membranes, facilitated by the sperm immobilization procedure and the gentle aspiration and reinjection of oocyte cytoplasm, triggers oocyte activation.<sup>621,622,623,624,625</sup> **In most cases, ICSI achieves fertilization rates comparable to those observed with conventional IVF in the absence of male factors (50–70%).**

ICSI can damage the meiotic spindle even if the area adjacent to the first polar body is avoided, because the second meiotic spindle varies in position and is not always located immediately beneath the first polar body.<sup>626,627</sup> A polarizing optical system that images the meiotic spindle can help to reduce the risk of spindle damage.<sup>628</sup>

The principal indication for ICSI is male factor infertility. Threshold semen parameters vary among centers but typically include severe oligospermia (<5 million sperm/mL), asthenospermia (<5% progressive motility), or teratospermia (<4% normal forms by strict criteria). ICSI also is indicated when using surgically retrieved sperm (because the number of mature sperm is relatively limited) or treatment includes PGD (because conventional insemination may result in extra sperm attached to the zona, which may contaminate the sample for diagnosis by polymerase chain reaction) and for couples with previous failed or poor fertilization with conventional IVF. Other circumstances where low fertilization efficiency or fertilization failure is anticipated may be viewed as an indication for ICSI. To guard against the potential consequences of an undiagnosed sperm function abnormality, some centers perform ICSI on at least a portion of the oocytes retrieved from women with unexplained infertility.<sup>119,629,630</sup> ICSI

also may yield higher fertilization rates for oocytes matured in vitro<sup>631,632,633</sup> and in cryopreserved oocytes,<sup>634,635</sup> which often exhibit a hardened zona (resistance to digestion by proteases).<sup>636,637,638,639</sup>

# EMBRYO CULTURE

---

Much attention has focused on culture media formulations. However, other components of the culture system are equally important, including the carbon dioxide (4–7%) and oxygen(5–20%) concentration, incubation volume (10–50  $\mu$ L), embryo group size (1–4), and the type of protein supplement (human serum albumin, recombinant albumin, synthetic serum substitute).<sup>640,641,642</sup>

Although the first human birth after IVF resulted from transfer of a blastocyst,<sup>2</sup> most transfers in the following years have involved earlier cleavage-stage embryos (day 2 or 3 after fertilization), primarily due to the lack of culture media that could reliably sustain embryos during the compaction (morula) and blastocyst stages of development. However, the identification of key regulators and a greater understanding of the changing physiologic requirements of growing embryos have fostered the development of “sequential” media, which vary in composition with the stage of embryo development.<sup>643</sup> **Whereas precompaction embryos prefer pyruvate as a nutrient and nonessential amino acids (found in higher concentrations in the oviduct), postcompaction embryos favor glucose and essential amino acids (found in higher concentrations in the uterus).**<sup>644,645</sup> Later on, “single-step” culture media containing nutrients, which embryos will need at different stages of development until post fertilization day 5/6, were introduced and provided similar clinical outcome with sequential media.<sup>646,647,648,649,650</sup> Single-step media without the need to replenish the medium on the 3rd day of culture allowed uninterrupted blastocyst culture in time-lapse monitoring systems. Commercially available media now provide the opportunity for any program to incorporate extended culture into its practice. In 2015, 59% of all embryo transfers in the United States were blastocyst transfers.<sup>5</sup>

Extended culture and blastocyst transfer offer several potential advantages over the transfer of cleavage-stage embryos:

- Better assessment of true viability, after activation of the embryonic genome, which occurs at 4- to 8-cell stage in human embryos
- Better synchronization between the stage of embryonic development and the endometrial environment
- The opportunity to perform PGT, when it is indicated
- Higher implantation rates, allowing transfer of fewer embryos, decreasing the risk for multiple pregnancy

**Extended culture is a more reliable test of viability and developmental potential because few embryonic genes are transcribed before the 8-cell stage and early**

measures of quality relate almost exclusively to the quality of the oocyte.<sup>651,652,653,654</sup> Postcompaction embryos also possess a transporting epithelium and can therefore better regulate their intracellular physiology and adapt to their environment.<sup>655,656,657</sup> Although pronuclear and cleavage-stage embryos can adapt to relatively hostile environments, survive, and successfully implant, those demands generate stresses that may compromise viability.<sup>645,658</sup> Extended culture may also help minimize adverse effects of an abnormal hormonal milieu on uterine receptivity and contractility, in the aftermath of ovarian stimulation.<sup>659,660,661,662</sup>

The strongest argument in favor of extended culture is that the implantation rate for blastocysts (30–60%) is significantly higher than for cleavage-stage embryos (12–20%).<sup>663,664,665,666,667,668,669</sup> Almost certainly, the higher implantation rate of blastocysts merely reflects better selection of the most viable embryos, as there is no evidence that extended culture improves the intrinsic quality of embryos.<sup>668</sup>

Not all have embraced the trend to wider use of extended culture, which also has at least two potential disadvantages:

- Embryos of lesser quality that may implant if transferred on day 3 may fail to reach the blastocyst stage in vitro, increasing the risk that there may be no embryos for transfer.
- Whereas higher blastocyst implantation rates permit transfer of fewer embryos, multiple pregnancy rates after transfer of two blastocysts are the same or higher than those observed after transfer of larger numbers of cleavage-stage embryos.

The results of a 2016 systematic review of 27 randomized trials comparing blastocyst and cleavage-stage embryo transfers illustrate both the principal advantage and disadvantage of extended culture, with a higher live birth rate per couple after blastocysts transfer (39% vs. 30.2%; OR = 1.48, CI = 1.20–1.82) and a higher rate of failure to transfer any embryos (OR = 2.50, 95% CI = 1.76–3.55).<sup>668</sup> The difference was independent of number of embryos transferred, prognosis, or day of randomization.

Indeed, the principal disadvantage of extended culture and blastocyst transfer is the higher risk for cancelled transfer. Although “omic” technologies (genomic, transcriptomic, proteomic, or metabolomic profiling) hold promise for helping to identify developmentally competent embryos, none has proven ready for application in clinical practice.<sup>670,671</sup> Evidence suggests that clinical measures (age, parity, AFC)<sup>672,673</sup> and laboratory parameters (fertilization method, number of blastomeres, and the degree of fragmentation observed on day 3)<sup>666,674,675,676</sup> can predict potential for blast formation, but the ability to generate blastocysts in vitro varies widely among individuals<sup>677</sup> and prediction models are not accurate enough to replace extended

culture for identification of embryos that will develop into blastocysts. More recently, time-lapse imaging systems (TLS), which capture images of embryos at predetermined intervals, for example, every 5–15 minutes, while the embryos are still in the culture environment, have been introduced.<sup>678</sup> In these systems, the images are digitally compiled to create a time-lapse sequence of embryo development. This allows assessment of the dynamic morphology of embryos without removing them from the incubator. Morphokinetic parameters, including the timing of cell divisions, intervals between cell cycles, and other development factors, for example, dynamic pronuclei patterns, presence of multinucleation and fragmentation, and blastomere symmetry, which may not be always observed or calculated with standard morphologic assessment at wider time intervals, are used to identify the embryo(s) that will develop to a blastocyst or will have the highest implantation potential. Several commercial or individualized algorithms, utilizing a variety of developmental milestones have been developed and provide a degree of accuracy in predicting blastocyst development as early as 48–72 hours of culture.<sup>679,680,681,682</sup> However, TLS algorithms are not yet precise replacements for extended culture. It is unclear if the monitoring or simply the undisturbed extended culture is helpful. Moreover, TLS algorithms do not reliably predict embryo euploidy or live birth.<sup>678,683,684</sup> Therefore, despite the availability of TLS, risk of cancelled transfer associated with extended culture is quite real (OR = 2.50, CI = 1.76–3.55).

**It is widely accepted that, in good prognosis elective single blastocyst transfer significantly reduces the incidence of twins without reducing the overall pregnancy rate.**<sup>685,686</sup> A study in donor oocyte recipients found that single blastocyst transfer yields a somewhat lower overall pregnancy rate, compared to transfer of two blastocysts, but reduces the twin rate dramatically.<sup>686</sup> Likewise, the U.S. National ART Data for 2015 show that women with good prognosis, that is, younger than age 35 with surplus embryos to cryopreserve, had live birth rates of 50% and 58.3% with single and double blastocyst transfers,<sup>5</sup> while multiple pregnancy rates were 2.2% versus 46%, respectively. It is disappointing that blastocyst transfer has not yet delivered on its promise to reduce the incidence of multiple pregnancy, primarily because few are willing to transfer only a single blastocyst.<sup>687,688,689</sup> In 2015, even though a lower percentage of blastocyst transfers involved three or more embryos (7% vs. 29%), the percentage of multiple-infant live births were higher with blastocyst transfer (24% vs. 21%).<sup>5</sup>

Most,<sup>690,691</sup> but not all studies,<sup>692</sup> have observed a two- to fivefold increase in the incidence of monozygotic twinning after blastocyst transfer. The cause is unknown, but culture-induced changes in the zona pellucida or embryo hatching have been implicated.<sup>693,694,695</sup> Most, but not all,<sup>696</sup> also have observed that blastocyst transfer

shifts the sex ratio, favoring males, compared to that observed in children conceived naturally,<sup>697</sup> or resulting from cleavage-stage embryo transfer.<sup>664,691,698,699,700</sup> The phenomenon may reflect the more rapid development of male embryos,<sup>701,702</sup> and the tendency to select the most advanced embryos for transfer.

A 2018 meta-analysis found the risk of preterm birth after fresh blastocyst transfer to be higher than after cleavage-stage transfer (RR = 1.15, CI = 1.05–1.25).<sup>703</sup> Women who received fresh blastocyst embryo transfers also have a higher risk of very preterm birth (RR = 1.16, CI = 1.02–1.31). However, there was no difference between the groups following FETs. Likewise, while blastocyst transfer resulted in fewer small for gestational age deliveries than cleavage-stage transfer in fresh cycles, rates were similar between the groups in frozen cycles. More large for gestational age (LGA) deliveries were observed after blastocyst compared with cleavage-stage transfer in frozen cycles (RR = 1.18, CI = 1.09–1.27), and there was no difference between the two groups in fresh cycles.<sup>703</sup> A number of reports have raised concern that longer duration of embryo culture may predispose to a higher risk of epigenetic (imprinting) alterations,<sup>704,705,706,707,708</sup> although subsequent studies examining the question have been reassuring.<sup>709,710</sup> Evidence from animal studies showing that developmental programming during the preimplantation interval can be influenced by manipulations in vitro<sup>711,712</sup> suggests that efforts to define and standardize culture conditions are justified and that careful long-term studies of children resulting from blastocyst transfer are warranted.

# Assisted Hatching

“Hatching” of the blastocyst from the zona pellucida is a natural process in which the embryo expands and emerges before implantation. Under culture conditions, the embryo erupts, leaving behind an empty zona, but in vivo, the mammalian zona normally dissolves. Evidence suggests that hatching in vivo results from embryo-uterine interactions with the embryo secreting an activator of zona lysins in the uterine fluid.<sup>713</sup> Zona thickness and relative resistance to enzyme digestion correlate with embryo quality and implantation potential.<sup>714,715,716,717</sup>

“Assisted hatching” describes a variety of techniques for artificially thinning or opening the zona. The procedure is intended primarily to improve implantation potential. Assisted hatching also offers the opportunity to remove cytoplasmic fragments from the perivitelline space,<sup>664</sup> but evidence indicates that removing fragments has no impact on implantation, clinical pregnancy, or live birth rates.<sup>718</sup> A wide assortment of methods has been used for assisted hatching, including zona drilling with acidified Tyrode solution,<sup>719,720,721,722</sup> partial zona dissection with a glass microneedle,<sup>723,724</sup> laser photoablation,<sup>725,726,727</sup> enzymatic thinning,<sup>728,729</sup> and the use of a piezo-micromanipulator.<sup>730</sup>

The idea that assisted hatching might improve implantation and pregnancy rates arose from observations that embryos subjected to zona drilling during early experience with assisted fertilization exhibited increased implantation efficiency.<sup>731</sup> Results of subsequent clinical trials varied widely with some suggesting that assisted hatching improved results in selected individuals having a relatively poor prognosis (advanced maternal age, previous failed IVF cycle, poor embryo morphology, thickened zona),<sup>719,722,724,725,726,727,730</sup> and others observing no demonstrable benefits, particularly when hatching was more broadly applied.<sup>720,721,723,732</sup> A 2012 systematic review and meta-analysis of combined data from 31 randomized trials involving 5,728 women found that assisted hatching increased clinical pregnancy rates (OR = 1.13, 95% CI = 1.01–1.27); however, the difference barely reached statistical significance.<sup>733,734</sup> The data on live birth is limited and does not suggest an improvement with assisted hatching (nine trials, OR = 1.03, CI = 0.85–1.26). While assisted hatching was associated with increased multiple pregnancy rates (14 trials, OR = 1.38, CI = 1.11–1.70), it had no impact on miscarriage rates (14 trials, OR = 1.03, CI = 0.69–1.54).<sup>733</sup> More recent studies and reviews yield conflicting results, even in subgroups of patients.

The varying results of clinical trials employing different techniques do not allow confident conclusions regarding the value of assisted hatching. **On balance, the weight of available evidence suggests that assisted hatching may have benefit for selected**



**individuals, especially those undergoing transfer with thawed blastocysts. However, routine or universal hatching is not warranted, particularly because the procedure also has potential risks. Hatching may cause damage to embryos and may increase the risk of multiple pregnancy and monozygotic twinning.**<sup>735,736,737,738,739,740,741,742</sup>

**Regarding the techniques utilized, thinning of the zona pellucida seems to have limited benefit and a higher degree of manipulation such as zona removal can provide better results.**<sup>735,738</sup> **Laser-assisted hatching is consistently reported to perform better than other methods.**

# Preimplantation Genetic Testing

Preimplantation genetic testing broadly describes procedures involving the removal of one or more nuclei of polar bodies from oocytes or cells (blastomeres, trophectoderm) from embryos to test for mutations or evaluate their chromosomal complement.<sup>131</sup> PGT for monogenic disorders (PGT-M, also called preimplantation genetic diagnosis [PGD]) describes testing for a known genetic abnormality carried by one or both parents to determine whether it has been transmitted to the oocyte or embryo. PGT for aneuploidy (PGT-A, also called PGS) describes testing for oocyte or embryo aneuploidy when the parents are known or presumed to be normal.<sup>131</sup>

## Techniques Used for Preimplantation Genetic Testing

The primary challenge in PGT is the small sample size, which varies between 1 and 10 cells depending on the type of biopsy. The past four decades witnessed extensive research that resulted in rapid introduction of technologies to improve diagnostic efficiency of PGT. Below is an introduction of the currently most relevant approaches. It is very likely that alternative technologies will be developed and have similar or better diagnostic accuracy in the near future.

### Fluorescence In Situ Hybridization

Fluorescence in situ hybridization (FISH) was introduced in ART in 1990. FISH utilizes probes labeled with colored fluorochromes that bind to specific DNA sequences unique to each chromosome. FISH can detect a large excess or missing piece of chromosomal material. After polar body or embryo biopsy, the cells are fixed on glass, the cytoplasm is dispersed, and the fluorescent probes are applied and allowed to hybridize with complimentary DNA sequences on targeted chromosomes. The different colored fluorescent signals can be observed with microscopy using filters of the appropriate wavelength. The copy number for each chromosomal segment of interest is determined by the number of fluorescent signals detected. When FISH is utilized for a monogenic disease or translocation, only the chromosomal region carrying the affected gene or chromosomal segments are targeted with the fluorescent-labeled complimentary DNA probe. When the purpose is aneuploidy screening, FISH allows assessment of a maximum of 12 chromosomes. In addition to testing for a limited number of chromosomes, and only small sections of those chromosomes, hybridization failure, signal overlap, and splitting are other technical limitations of FISH for aneuploidy testing. Introduction of novel techniques that allow simultaneous assessment of all chromosomes almost in their entirety, having potential to assess monogenic disease/translocations together with aneuploidy, and failure to demonstrate a clinical benefit of PGT-M with FISH has led to abandoning the technology in favor of newer

methods described below.

## **Array Comparative Genomic Hybridization**

In array comparative genomic hybridization (aCGH), DNA from the biopsied cells is amplified, labeled, and hybridized on a DNA microarray together with a differently labeled control DNA. The array is then scanned, and intensity of both hybridization signals are measured and plotted. Differences between the signals from the test and control DNA allow identification of quantitative deviations, that is, extra or missing DNA sequences, in the test DNA. While aCGH can detect aneuploidy and unbalanced translocations, balanced translocations, and inversions go undetected since there is no extra or missing chromosomal content, despite being mislocated. Likewise, aCGH cannot detect polyploidy since test DNA segments all still contribute proportionately equally to hybridization process.

## **Single Nucleotide Polymorphism Array**

Humans are diploid organisms as they have two **alleles** at each genetic locus, with one **allele** inherited from each parent. Single nucleotide polymorphisms (SNPs) are defined as loci with alleles that differ at a single base, with the rarer allele having a frequency of at least 1% in a random set of individuals in a population.

Following the amplification of test DNA sample, analysis of the ratio of the intensity of both alleles at heterozygous loci allows detection of duplications in, and deletions from whole chromosomes in small regions. SNP arrays also allow determination of parental origin of abnormalities, and detection of uniparental disomy. However, these require genotyping the parents. Allowing detection of parental origin and high resolution renders SNP array useful for PGT for monogenic disease and unbalanced translocation. SNP array also allows PGT for aneuploidy by assessing copy number of all 24 chromosomes.

## **Quantitative PCR**

Quantitative PCR (qPCR) can be used for diagnosis of monogenic disorders using primers targeting the mutation of interest. When applied for aneuploidy, qPCR involves amplification of at least two sequences from each arm of each chromosome by using high-order multiplex PCR. Then each product is rapidly quantified by qPCR, and the amounts of products are compared to each other to calculate total genomic content. An advantage of qPCR is running multiplex PCR directly on the test DNA, avoiding whole genome amplification.

## **Next-Generation Sequencing**

Next-generation sequencing (NGS) is high-throughput sequencing and is the term used to describe a number of different sequencing technologies. Briefly, the test DNA is amplified and cleaved into short fragments, which are ligated to generic adaptors and annealed to a slide. The slide is flooded with fluorescent-labeled nucleotides and DNA polymerase, and depending on the particular technology, snapshots are taken (Illumina and Roche 454) or pH changes are monitored (Ion Torrent Proton/PGM sequencing) after addition of each base. The process is rapidly repeated many times and bioinformatics is utilized to construct the sequences with the optical information collected. Hundreds of thousands of fragments are sequenced simultaneously, until the desired sequencing depth, that is, the number of sequence reads for each given position in the genome, is reached. The generated sequence data from all chromosomes are compared with the reference genome and counted. Since the number of sequences from a particular chromosome should be proportional to the copy number of that chromosome, aneuploidy will result in greater or lower numbers of reads. NGS allows detection of whole chromosome aneuploidy, segmental chromosome imbalances, and single-gene disease.

## **Timing of Biopsy for Preimplantation Genetic Testing**

Preimplantation genetic testing can be performed on polar bodies removed from oocytes before and after fertilization (also called preconception diagnosis)<sup>743</sup> or on blastomeres (obtained from cleavage-stage embryos) or on trophoctoderm biopsies (removed from blastocysts). The equipment and techniques required for embryo biopsy are the same as for ICSI and related procedures (assisted hatching). After creating an opening in the zona pellucida using a laser or acid Tyrode solution, the polar body, blastomere(s), or trophoctoderm biopsy is extracted for genetic analysis.

Preconception diagnosis is cumbersome and often requires sequential removal of both the first and second polar bodies to decrease misdiagnoses.<sup>744</sup> Indeed, a recent study involving the biopsy of the first and second polar bodies for aneuploidy analysis in women of advanced maternal age (mean age 40.0) revealed an approximately equal proportion of errors in both meiotic divisions. Interestingly, in about half of cases where there had been an error in meiosis I, this error was balanced in meiosis II.<sup>745</sup> Therefore, in the zygote, there were more aneuploidies resulting from errors in meiosis II than meiosis I. Even if both polar bodies are analyzed, mitotic errors in the embryo and any resulting from paternal inheritance cannot be detected. Moreover, when polar body analysis is inconclusive, embryo biopsy must be performed. The cumulative trauma likely exceeds that of a single cleavage-stage embryo or trophoctoderm biopsy.

To detect abnormalities in cleavage-stage embryos, one or two nucleated cells are removed, typically on the 3rd day after fertilization (the 6–8 cell stage), before

compaction when the blastomeres become more tightly adherent.<sup>746</sup> After biopsy, the embryo can be placed in extended culture to develop to the blastocyst stage, or cryopreserved until the results of genetic analysis can be completed. A potential advantage of blastomere biopsy is its compatibility with fresh embryo transfer on day 5 to day 6 of embryo development, if the test results become available within 2 days of biopsy.<sup>747</sup> Extracting two blastomeres is more traumatic for embryo development and should be avoided, if possible.<sup>748</sup> A randomized controlled study showed that even single blastomere biopsy by an experienced operator in a high-volume laboratory harms implantation potential of embryos, leading to a decrease in sustained implantation rates (50% implantation rate in unbiopsied vs. 30% in biopsied sibling embryos in the same cycle).<sup>749</sup>

The risk of mosaicism, that is, the existence of different blastomeres with a different genetic constitution, is another drawback of blastomere biopsy. Mosaicism can lead to false-positive or false-negative results, when the biopsied blastomere is not representative of the embryo.<sup>747,750</sup>

A human blastocyst is 0.1–0.2 mm in size and has approximately 200 cells; typically, 5–10 trophoctoderm cells are removed during the biopsy. The above mentioned randomized trial demonstrated that the developmental potential of embryos undergoing trophoctoderm biopsy at the blastocyst stage was equivalent to the nonbiopsied control siblings.<sup>749,751,752,753</sup> Later sampling leaves little time for analysis before the embryo must be transferred or frozen. Yet, currently trophoctoderm biopsy is preferred over blastocyst biopsy. Although biopsied embryos might be more sensitive to the rigors of freezing and thawing, technical modifications in cryopreservation techniques have largely overcome the limitation.<sup>750,754,755</sup> A 2017 RCT compared clinical outcome following fresh or vitrified warmed transfer of euploid blastocysts and reported similar implantation (67% vs. 75%, respectively) and live birth rates (59% vs. 77%, respectively).<sup>756</sup> **Overall trophoctoderm biopsy is currently the most reliable and least traumatic option for preimplantation genetic testing.**

## Preimplantation Genetic Testing for Monogenic Disorders

Preimplantation genetic testing for monogenic disorders (PGT-M) also called PGD is indicated for couples at risk for transmitting a specific genetic abnormality to their offspring. The risk of transmission is 50% for carriers of autosomal dominant disorders (e.g., Marfan syndrome), 25% for carriers of autosomal recessive disorders (e.g., cystic fibrosis), and 25% (half of male embryos) for female carriers of X-linked disorders (e.g., hemophilia A). PGT-M also can be used to detect genetic mutations that predispose to a disease (early-onset Alzheimer disease,<sup>757</sup> familial adenomatous

polyposis coli,<sup>758</sup> p53 tumor suppressor gene mutations<sup>759</sup>), to detect an unbalanced chromosomal translocation in the embryos of a couple harboring a balanced translocation, and for human leukocyte antigen (HLA) matching of embryos to an existing child of the same parents (bone marrow transplantation).<sup>760</sup>

PCR is the method of choice for PGT-M, since customized PCR can detect particular mutations or changes in the DNA sequence. Yet, new technologies can be utilized for diagnosis of some diseases. Parental SNP genotypes and Mendelian genetic analysis can be used to generate a karyomap for each chromosome or chromosome segment inherited by each embryo.<sup>761</sup> Although karyomapping is commercially available and theoretically applicable to all monogenic disease without the need for prior optimization of the assay for the disease concerned, relatively higher cost and the requirement for genetic information from an affected individual or embryos as reference limits the use of SNP for PGT-M.<sup>762</sup> Array CGH is incapable of detecting single-gene mutations and can only be used to detect copy number variations. Recently, targeted NGS was shown to reliably detect cystic fibrosis, Walker-Warburg syndrome, familial dysautonomia, X-linked hypophosphatemic rickets, and neurofibromatosis 1.<sup>763</sup> The potential for simultaneously screening for both monogenic disease and aneuploidy is noteworthy. In one study, approximately 50% of PGT-M unaffected embryos were aneuploid.<sup>764</sup> Accordingly, when the clinical outcomes of PGT-M/PGT-A versus PGT-M alone were compared, implantation rates were 75% versus 53%, live birth rates were 59.4% versus 37.5%, and miscarriage rates were 20% versus 40%, respectively. Therefore, although patients performing PGT-M/PGT-A may ultimately have fewer embryos for transfer, these embryos will potentially have a higher reproductive potential.<sup>132</sup>

Currently, aCGH, SNP microarray, or NGS with trophoctoderm biopsy are used for PGT in balanced reciprocal and Robertsonian translocations. For couples harboring a balanced chromosomal translocation, whether PGT decreases the risk of miscarriage is debated. A 2018 systematic review of studies reporting reproductive outcomes in couples with recurrent pregnancy loss due to structural chromosomal rearrangements, live birth rates after natural conception ranged between 25% and 71% among couples with a history of RPL and translocations as opposed to 26.7% and 87% after IVF-PGT.<sup>765</sup> The miscarriage rate ranged between 25% and 55.6% after natural conception as opposed to 5.3% and 39% after IVF-PGT.<sup>765</sup> In two comparative studies including a total of 50 couples, the live birth rates were 66.6% and 67.6% in the IVF-PGD groups compared with 55.8% and 65.4% in the natural conception groups. Time to live birth varied greatly being 12.4 and 23.3 months in the IVF-PGT groups compared with 11.4 and 17.5 months in the natural conception groups.<sup>766,767</sup> It should be noted that studies included in this review utilized suboptimal techniques of cleavage-stage biopsy and

FISH for PGT, and whether trophectoderm biopsy and comprehensive chromosomal screening (CCS) yields the same result should be seen. Regardless, most couples with balanced translocations ultimately will achieve a successful pregnancy without IVF and PGT.<sup>765,768,769,770</sup>

**PGT-M offers couples who carry serious genetic disorders the opportunity to have a healthy child without the practical and ethical problems associated with terminating an affected pregnancy after traditional prenatal diagnosis (chorionic villus sampling, amniocentesis). However, careful counseling is required and must include the following:**

- The possibility of diagnostic error or inconclusive results
- The possibility that the chance for success may be reduced, compared to that expected when PGT-M is not performed, due to embryo trauma and the smaller number of embryos available after abnormal embryos are excluded
- The need for conventional prenatal diagnosis to confirm the accuracy of PGT-M

## **Preimplantation Genetic Testing for Aneuploidy**

Aneuploidy is common in human embryos, most resulting from meiotic errors in the oocyte, which increase in prevalence with advancing age. Although aneuploidy is more common in morphologically abnormal embryos, even embryos with normal morphology and developmental progress may be aneuploid.<sup>771,767</sup> As a diagnostic test, PGT-A is not expected to improve total reproductive potential of an egg retrieval cycle, that is, cumulative pregnancy rate after exhaustion of all available embryos, fresh and frozen from a single cycle. However, embryo biopsy, aneuploidy screening, and transfer of proven euploid embryos would be expected to improve implantation efficiency and to reduce the incidence of futile embryo transfers and possibly miscarriage in pregnancies resulting from IVF. Older women with relatively higher rate of embryo aneuploidy and good prognosis patients with several embryos available to choose from for embryo transfer are the most obvious potential candidates for PGT-A. Others include women with a history of recurrent pregnancy loss, those with repeated IVF failure despite transfer of morphologically normal embryos, and couples with severe male factor infertility.

Initial PGT-A utilized blastomere biopsy and FISH allowing the examination of a limited number of chromosomes. As such, all but one RCT of this initial approach failed to demonstrate a benefit.<sup>773,774,775,776</sup> Furthermore, two of these RCTs reported decreased live birth rates with PGT-A with blastomere biopsy and FISH.<sup>775,776</sup> As a result of these well-designed studies, the American Society for Reproductive Medicine (ASRM) and the European Society for Human Reproduction and Embryology released a

statement advising against the use of PGT-A with FISH.

Since then, alternative techniques have become available (discussed above) for CCS, and new RCTs provided high-quality evidence regarding IVF pregnancy outcomes in select populations with PGT-A.<sup>132</sup> A RCT assessing the effectiveness of PGT-A utilized first and second polar body biopsy with aCGH in 396 women aged 36–40 years.<sup>777</sup> Fifty of the 205 (24%) participants in the chromosome screening group had a live birth with intervention within 1 year, compared to 45 of the 191 in the group without intervention (24%) (difference = 0.83%, 95% CI = –7.60 to 9.18%). In the CCS group, significantly fewer participants underwent an embryo transfer (relative risk [RR] = 0.81, 95% CI = 0.74–0.89) and fewer had a miscarriage (RR = 0.48, 95% CI = 0.26–0.90).<sup>777</sup> The rate of embryo development was similar between the two groups (53% vs. 50% morphologically transferable) suggesting that the polar body biopsy procedure did not have a detrimental effect; however, the analysis was inconclusive for 8% of oocytes assessed by aCGH.<sup>777</sup> Due to the diagnostic limitations previously discussed, as well as the findings of this study, a polar body-based CCS approach is not likely to be widely utilized in the near future.

Another multinational study randomized women with advanced maternal age (38–41 years old), prior to cycle start to routine blastocyst transfer versus a PGT-A group that had a biopsy of a single blastomere on day 3 with fresh blastocyst transfer on day 5 after the retrieval.<sup>774</sup> The live birth rates were significantly higher in the PGT-A group when analyzed per embryo transfer (52.9% vs. 24.2%,  $p < 0.0002$ ) and per started cycle (36% vs. 21.9%,  $p < 0.031$ ). Moreover, the miscarriage rate was significantly lower in the PGT-A group (2.7% vs. 39%,  $p = 0.0007$ ). When the outcomes for FET cycles performed during the 6 months after the completion of the study were added, cumulative live birth rates were similar (37% vs. 33.3% in PGT-A and controls, respectively). However, the mean number of ETs needed per live birth was lower in the PGT-A group compared with the control group (1.8 vs. 3.7), as was the time to pregnancy (7.7 vs. 14.9 weeks).<sup>774</sup> The use of blastomere biopsy could be regarded as a factor limiting the generalizability of the results of this study.

Three other RCTs involved women with better prognosis, that is, younger than 35 years or having at least two blastocysts amenable to biopsy. The RCT including 112 women younger than 35 years, with tubal or male factor infertility, and without any prior failed cycles utilized trophoctoderm biopsy on day 5, aCGH, and fresh transfer on day 6.<sup>778</sup> Blastocyst for transfer in the control group were selected by traditional morphologic assessment, and also transferred on day 6. Array CGH group achieved significantly higher ongoing pregnancy rates (69.1% vs. 41.7%,  $p = 0.009$ ), while miscarriage rate was similar between PGT-A and control groups (2.6% vs. 9.1%, in PGT-A and controls, respectively,  $p > 0.05$ ). Another RCT included 175 women



younger than 42 years old who had at least two expanded blastocyst on day 5 or 6, compared clinical outcome of elective single euploid blastocyst transfer with transfer of two morphologically selected blastocysts.<sup>779</sup> Trophectoderm biopsy and qPCR were used for PGT-A. Ongoing pregnancy rate beyond 20 weeks were similar in the two groups (60.7% vs. 65.1%), with significantly lower multiple pregnancy rate in the PGT-A group (0% vs. 53.4%,  $p < 0.05$ ). The risks of preterm delivery, low birth weight, and neonatal intensive care admission were also lower with PGT-A.<sup>780</sup> Another RCT randomized 155 women with two or more blastocysts on day 5 to trophectoderm biopsy with qPCR-based CCS on day 5 and transfer on day 6 or morphologic grading and embryo transfer on day 5.<sup>781</sup> Patients in the control group had significantly more embryos transferred than the PGT-A group (2.0 vs. 1.86,  $p < 0.001$ ), which was due to 10 patients in the study group having only one euploid embryo for transfer while all patients in the control group underwent double embryo transfer. Clinical implantation rates were significantly higher in the PGT-A group (79.8% vs. 63.2%, in PGT-A and controls, respectively,  $p = 0.002$ ). Delivery rate per cycle was also significantly higher in the PGT-A group (84.7% vs. 67.5%,  $p = 0.01$ ). Based on the reported data, the calculated spontaneous abortion rates were 8.9% and 21.1%, in PGT-A and control groups, respectively. These three RCTs suggest elective single euploid blastocyst transfer selected by PGT-A with trophectoderm biopsy, and comprehensive chromosome screening with 24 chromosomes results in higher implantation, pregnancy, and delivery rates following the first embryo transfer of an egg retrieval cycle in women with good ovarian reserve.

A 2017 trial randomized 323 women aged 25–34 years, 170 women aged 35–37 years, and 95 women aged 38–40 years to PGT-A or morphologic blastocyst assessment at 34 clinics in 4 countries. Women between 25 and 40 years of age, with less than 3 prior ART failures and less than 2 prior miscarriages, and who are not a known carrier of a single-gene disorder or chromosomal abnormality were recruited. Decreased ovarian reserve, oligospermia, azoospermia, use of donor oocytes or gestational carrier, and undergoing PGT outside the study context were exclusion criteria. Trophectoderm biopsy and NGS were utilized for PGT-A. In both arms, blastocyst-stage embryos underwent vitrification for single-embryo transfer in a later cycle. In women younger than 35, 20-week ongoing pregnancy rates were not different between PGT-A and control groups (53% vs. 49%), while there was a significant improvement in women 35–40 years old (51% vs. 37%,  $p = 0.035$ ). Miscarriage rates ranged between 8% and 11% in age brackets and were not significantly different between the PGT-A and control groups.<sup>782</sup> Overall, this RCT failed to replicate the favorable results achieved with the above mentioned RCTs in women with good prognosis while it showed a benefit in women over 35 years old.

A recurring theme in PGT-A is mosaicism and the complexity of determining the

reproductive potential of human embryos diagnosed as mosaic. In one study, chromosomal mosaicism was diagnosed by aCGH in 181 of 3,802 blastocysts (4.8%).<sup>783</sup> Eighteen women who did not have any euploid embryos underwent single-embryo transfer of mosaic embryos, eight pregnancies ensued, of which six resulted in the birth of a singleton infant at term. All pregnancies that went to term were confirmed, by means of sampling of the chorionic villi, to have a normal karyotype. The findings of this study suggest that embryos diagnosed as mosaic can develop into healthy euploid newborns.<sup>783</sup> These findings should be kept in mind when counseling women who undergo IVF resulting in mosaic embryos but no euploid embryos.

**Techniques applied for PGT-A are rapidly evolving and many of the key techniques used in published RCTs are no longer in use; qPCR and aCGH have been replaced by NGS-based analysis for comprehensive chromosome screening, fresh transfers have been replaced by thaw transfers of cryopreserved embryos. NGS is also being reassessed regarding the best way to amplify the genome and how to achieve the necessary depth of sequencing in a most cost-efficient way. The next decade will uncover whether these developments will further improve diagnostic accuracy of PGT-A and help determine the appropriate applications. While some express concern about the diagnostic accuracy, many view this approach for embryonic selection as an avenue to reduced time to live birth and increased live birth rate per transfer, at least in selected populations.**

# EMBRYO TRANSFER

---

Although embryos have been transferred successfully at any stage of early development, from zygote to blastocyst, transfer is most commonly performed 5 days after oocyte retrieval, while some programs continue performing day 3 transfers, at least for certain subsets of patients. The relative advantages and disadvantages of extended culture to the blastocyst stage are discussed above. Systems for grading the quality of embryos vary among programs, but the morphologic features on which grading is based are similar and depend on morphology and cleavage rate.

The essential features of embryo transfer have not changed significantly since the procedure was first described in 1984.<sup>784</sup> Although the impact of transfer technique on results is difficult to study, most clinicians believe it is as important as embryo quality.<sup>785</sup> The success of the procedure is clinician dependent.<sup>786,787,788,789</sup> Yet, a 2017 survey showed that all clinicians were allowed to perform embryo transfer, regardless of their skill level, without a standardized technique.<sup>790</sup> This has led the Practice Committee of the American Society of Reproductive Medicine (ASRM) to prepare a guideline and a standard embryo transfer protocol template.<sup>786,791</sup> Further, the ASRM has developed embryo transfer simulators that can be used for training and standardization.

Embryo transfer is typically a pain-free procedure. Thus, neither anesthesia nor analgesics are required routinely. Despite some theoretical advantages, evidence for an effect of massage, relaxation techniques, acupuncture, transcutaneous electrical acupoint stimulation, and Chinese medicine is limited and does not suggest an unequivocal benefit from these adjuvant interventions. Likewise, routine use of broad-spectrum antibiotics seems unnecessary.

A trial transfer before the cycle begins can identify women with cervical stenosis or an acutely angled cervicouterine junction that can make transfer technically difficult to perform.<sup>792</sup> Several studies have suggested that, when required, cervical dilation is best performed before the cycle begins;<sup>793,794,795,796</sup> shorter intervals of time between dilation and transfer may be insufficient to allow the endometrium to recover from the trauma or bacterial contamination and are associated with significantly lower pregnancy rates. Dilation with laminaria in advance of the treatment cycle also can be effective.<sup>797</sup> The notes from a prior mock or real embryo transfer, when available, should be reviewed before embryo transfer to prepare for an anticipated difficult transfer and to facilitate the procedure.

Embryo transfer under transabdominal ultrasonography offers a number of advantages over a blind technique. **Ultrasonography facilitates the insertion of soft**

**catheters, confirms correct positioning, and avoids inadvertent trauma to the fundal endometrium.**<sup>798,799</sup> Urine in the bladder also may help to straighten the plane of the cervicouterine junction.<sup>800,801</sup> Uterine position and orientation often change in the interval between the mock transfer and the actual transfer, primarily due to the ovarian enlargement.<sup>269</sup> Two recent systematic reviews, both including 21 RCTs, reported significantly higher live birth rate after guided transfers<sup>802,803</sup>; the probability of a live birth was increased almost 1.5-folds with ultrasound guidance.

The use of sterile latex-free gloves is preferred as per common practice and standard expected occupational safety and health administration requirements. Two-thirds of physicians report using surgical masks during embryo transfer.<sup>791</sup>

An embryo transfer has a number of potential pitfalls. An appropriate size speculum should be used to expose the cervix easily, and any remnants of vaginal progesterone and secretions are gently cleaned with sterile saline or embryo transfer media. Mucus within the cervical canal may plug the catheter tip, resulting in retained embryos or improper placement.<sup>793,804,805</sup> Cervical mucus also can be a source of bacterial contamination of the endometrial cavity, adversely affecting results.<sup>805,806</sup> Any obvious or excess cervical mucus is best removed before transfer.<sup>807,808,809</sup> However, cervical trauma should be avoided and excessive lavage is not shown to be helpful.<sup>798</sup>

Transfer catheters vary widely in design. Current catheters are comprised of an outer sheath and an inner catheter, the latter carrying the embryos. Definitions of “soft” and “firm” catheters vary in the literature. It is reasonable to categorize all catheters with a soft inner catheter as a soft catheter, since the aim is to dislodge the embryos without endometrial trauma.<sup>786</sup> Stiff catheters and those with a rigid outer sheath are easier to insert but more traumatic than soft catheters, which can better follow the contours of the endocervix and endometrium.<sup>810</sup> Controlled trials consistently show better clinical outcome with soft catheters, with 1.4-fold (CI = 1.2–1.6) higher pregnancy rates.<sup>786</sup> However, no soft catheter performs significantly better than another soft catheter, and commercially available soft catheters are regarded to perform similarly.<sup>786,811</sup> If a soft catheter with a firm outer sheath is used, pushing the tip of the outer sheath beyond internal ostium can cause endometrial trauma and lower pregnancy rates.<sup>812</sup> When transfer proves difficult, a malleable stylet can be used to introduce the outer sheath of a soft catheter just beyond the internal cervical os, then replaced by the soft inner catheter containing the embryos (“afterloading”). Transmyometrial embryo transfer under ultrasound guidance has been described<sup>813,814</sup> but yields lower pregnancy rates,<sup>815</sup> probably relating to uterine contractions,<sup>816</sup> and rarely should be necessary.

The tip of the embryo transfer catheter is placed at the upper or middle area of the

endometrial cavity before dislodging the embryos.<sup>817,818,819,820,821,822</sup> Transfers higher in the fundus may increase the risk of ectopic pregnancy,<sup>823,824</sup> and low transfers may result in cervical implantations.<sup>825</sup>

Larger volumes of transfer media (>20–50 µL) or air above the column of media may increase the risk that embryos may be expelled from the uterus or propelled into the fallopian tube.<sup>826,827</sup> The concentration of protein and the viscosity of transfer medium do not appear to affect results.<sup>828,829</sup> Whether adherence compounds containing hyaluronic acid in embryo transfer media improve clinical pregnancy rates is controversial.<sup>830,831,832,833,834,835</sup> Syringes that may be used with a transfer catheter also vary in design and performance characteristics. Even though quantitative analysis of injection speed is difficult, fast injection close to the fundus has been associated with increased ectopic pregnancy rates.<sup>786,836,837,838,839</sup> While the presence of mucus on the catheter tip is not associated with decreased pregnancy and live birth rates, results are mixed regarding the effect of the presence of blood.<sup>786,793,804,840,841,842,843,844,845,846,847,848,849</sup> Yet, it is prudent to avoid cervical and/or endometrial trauma during embryo transfer.

Embryos adhering to the outside of the catheter after transfer can be relocated or removed inadvertently when the catheter is withdrawn.<sup>798,826</sup> Microscopic examination of the catheter immediately after transfer identifies retained embryos requiring a second transfer procedure; immediate retransfer of retained embryos does not seem to affect implantation, pregnancy, or abortion rates.<sup>786,793,826,840,845,846,847,848,849,850,851,852,853,854,855,856</sup>

There is good quality evidence to recommend against bed rest after embryo transfer.<sup>786,857,858</sup> Indeed, a 2016 meta-analysis suggests possible harm.<sup>859</sup> Thus, patients can resume normal daily activities; physical activity and diet have no demonstrable effect on outcomes. Mild intermittent cramping and bloating are normal symptoms, but moderate or severe pain requires evaluation to exclude infection, ovarian torsion, OHSS, and other causes of abdominal pain.

In summary, the goal of embryo transfer is to deliver embryos to the uterus in an accurate and atraumatic fashion. **A preliminary trial transfer can identify women who may benefit from cervical dilation before treatment begins, and transfers in small volumes using soft catheters guided by ultrasonography produce the best results.**<sup>786</sup>

# Embryo Transfer Guidelines

The goal of IVF is to maximize pregnancy rates while, at the same time, minimizing multiple gestations, high-order multiple gestations in particular. The likelihood of success increases with the number of embryos transferred, to a point, beyond which only the risk of multiple pregnancy increases.<sup>860,861,862</sup> Multiple pregnancy does not only increase the risk of preterm birth and associated neonatal and infant morbidity and mortality but is also associated with maternal morbidity.<sup>863</sup> Moreover, preterm deliveries that result from ART-associated multiple pregnancies add a substantial burden to overall U.S. health care expenditure annually.<sup>864</sup> Financial concerns affect couples' preferences for number of embryos to be transferred, and public reimbursement plans accompanied by strict regulations for number of embryos to be transferred seem to increase not only ART utilization rates but also the uptake of single-embryo transfers.<sup>865,866,867,868</sup> Strict regulations on the number of embryos transferred, as defined by law in some countries, reduce the number of multiple pregnancies and all but eliminate high-order multiple gestations<sup>860</sup>; however, they do not allow treatment to be individualized, considering unique patient characteristics and circumstances (age, the number and quality of embryos, the opportunity for cryopreservation, and the outcome of any previous cycles), or to be adjusted according to new clinical data.<sup>869,870,871</sup> Registry data from the United States strongly suggest that regulations ignoring the unique circumstances of individual women inevitably reduce the chance of pregnancy.<sup>861</sup>

In essence, elective single-embryo transfer could be considered for almost all women, since cumulative live birth rate per egg retrieval cycle would be maintained following consecutive FETs with current success achieved in embryo cryopreservation. Indeed, clinics that perform higher rates of elective single-embryo transfer in women aged less than 38 years have decreased rates of multiple gestation, with no significant impact on cumulative live birth rates.<sup>872</sup> The data generated by individual programs can guide the decision regarding the optimal number of embryos to transfer in women of varying age and clinical characteristics. In their absence, the Society for Assisted Reproductive Technology (SART) and the ASRM have offered guidelines. First published in 1998,<sup>873</sup> the guidelines have been revised several times, based on new clinical data reflecting steady advances in ART indicating that fewer embryos can be transferred without adversely affecting the likelihood for success.<sup>874,875</sup> The guidelines issued in 2017 categorize patients as those with a favorable prognosis and those without.<sup>876</sup> The following characteristics have been associated with a favorable prognosis: (1) expectation of one or more high-quality embryos available for cryopreservation, (2) euploid embryos, and (3) previous live birth after an IVF cycle. Additional favorable criteria for FET cycles include the availability of vitrified, high-

quality, day 5, or day 6 blastocysts for transfer.<sup>876</sup> Recommended number of embryos to be transferred is based on the age of the woman, presence or absence of favorable characteristics, and stage of embryos, that is, cleavage or blastocyst. The recommendations are noted in the section that follows.

## Recommendations

### Patients with a favorable prognosis:

- In patients of any age, transfer of a known euploid embryo has the most favorable prognosis and should be limited to one.
- Patients under the age of 35 should be encouraged to receive a single-embryo transfer, regardless of the embryo stage.
- For patients between 35 and 37 years of age, strong consideration should be made for a single-embryo transfer.
- For patients between 38 and 40 years of age, no more than three cleavage-stage embryos or two blastocysts should be transferred. In cases where euploid embryos are available, a single blastocyst embryo transfer should be the norm.
- Patients 41–42 years of age should plan to receive no more than four cleavage-stage embryos or three blastocysts. In cases where euploid embryos are available, a single blastocyst transfer should be the norm.

### Other scenarios:

- In all age groups, patients who do not meet the criteria for a favorable prognosis may have an additional embryo transferred according to individual circumstances (Table 28.2). The patient must be counseled regarding the additional risk of twin or higher-order multiple pregnancy.
- If otherwise favorable patients fail to conceive after multiple cycles with high-quality embryo(s) transferred, physicians and patients may consider proceeding with an additional embryo to be transferred.
- Patients with a coexisting medical condition for which a multiple pregnancy may increase the risk of significant morbidity should not have more than one embryo transferred.
- In the rare cases where the number of embryos or blastocysts transferred exceeds recommended limits, both the counseling and the justification must be documented in the patient's permanent medical record.
- In women  $\geq 43$  years of age, there are insufficient data to recommend a limit on the number of embryos to transfer when the patient uses her own oocytes. Caution should be exercised as the risk associated with multiple pregnancy increases

dramatically with advancing maternal age.

**TABLE 28.2 Recommendations for the Limit to the Number of Embryos to Transfer**



Prognosis	Age in years			
	<35	35–37	38–40	41–42
Cleavage-stage embryos <sup>a</sup>				
Euploid	1	1	1	1
Other favorable <sup>b</sup>	1	1	≤3	≤4
All others	≤2	≤3	≤4	≤5
Blastocysts <sup>a</sup>				
Euploid	1	1	1	1
Other favorable <sup>b</sup>	1	1	≤2	≤3
All others	≤2	≤2	≤3	≤3

<sup>a</sup>See text for more complete explanations.

<sup>b</sup>Other favorable = Any ONE of these criteria: fresh cycle, expectation of 1 or more high-quality embryos available for cryopreservation or previous live birth after an IVF cycle; FET cycle, availability of vitrified day 5 or day 6 blastocysts, euploid embryos, first FET cycle, or previous live birth after an IVF cycle.

Please note: Justification for transferring additional embryos beyond recommended limits should be clearly documented in the patient's medical record.

In donor oocyte cycles, the age of the donor should be used to determine the appropriate number of embryos to transfer. For example, when the donor is less than 35 years of age and other favorable criteria exist, single-embryo transfer should be planned.

In frozen embryo transfer cycles, favorable characteristics should be based on the age of the woman when the embryos were frozen and include the presence of high-quality vitrified embryos, euploid embryos, first FET cycle, or previous live birth after an IVF cycle. Embryo transfer numbers should not exceed the recommended limit on the number of fresh embryos transferred for each age group.

Overall, the weight of available evidence indicates that an optimal balance between pregnancy rates and the risk of multiple pregnancy can be achieved with a flexible embryo transfer policy based on maternal age, embryo quality, and the availability of surplus high-quality embryos (see [Table 28.3](#)).

**TABLE 28.3 Live Births per Transfer and Percentages of Multiple-Infant Births for Women Under Age 35 with Surplus Embryos Suitable for Cryopreservation, by Number of Embryos Transferred<sup>5</sup>**

Embryos Transferred	Live Births per Transfer	Singletons	Twins	Triplets +
1	49.5%	97.9%	2.1%	<0.1%
2	56.2%	56.3%	42.7%	1%
3	50.9%	62.4%	28.2%	9.4%
4+	44.4%	100%	0%	0%

# LUTEAL PHASE SUPPORT

---

Controlled ovarian hyperstimulation with exogenous gonadotropins generally yields multiple corpora lutea that might well be expected to sustain supraphysiologic serum concentrations of estradiol and progesterone during the luteal phase of IVF cycles. Cotreatment with GnRH analogs for prevention of premature LH surge and luteinization effectively suppresses endogenous LH secretion, as intended. Unfortunately, even though agonist and antagonist treatment end abruptly on the day of hCG administration, residual suppression of endogenous LH does not. **Abnormally low levels of LH during the luteal phase may be insufficient to stimulate and maintain the level of luteal function required to promote timely endometrial maturation in preparation for implantation or to support an early pregnancy once established.** Endogenous LH secretion can remain suppressed for as long as 10 days after treatment with a GnRH agonist ends and luteal function is frequently inadequate in amount or duration.<sup>877</sup> Although antagonists have a much shorter duration of action, they often have the same consequence. Integrated estradiol and progesterone levels are abnormally low, and luteal phase duration is grossly short in GnRH antagonist treatment cycles, particularly when a GnRH agonist rather than hCG is used to stimulate the final stages of oocyte maturation.<sup>878</sup> Because there is no way to predict who may or may not require luteal support in any given cycle, some form of treatment must be provided for all.

Progesterone supplementation generally begins on the day of oocyte retrieval or at the time of embryo transfer.<sup>879,880,881</sup> Numerous clinical trials have compared clinical, ongoing, or delivered pregnancy rates or spontaneous abortion rates between groups receiving treatment with different luteal phase support regimens, with varying results. Progesterone has been administered orally (300–800 mg daily); vaginally as a bioadhesive 8% gel (90 mg daily), cream, or tablet (100–600 mg daily); and by intramuscular (25–50 mg daily) or subcutaneous (25 mg daily) injection; supplemental doses of hCG generally have been administered every 3 days (1,500–2,500 IU). There is no evidence that any one treatment regimen is superior, although results achieved with oral progesterone have been inconsistent. However, dydrogesteron (30 mg daily), a retroprogesteron, which has higher oral bioavailability than micronized progesterone, has been shown to be as effective as vaginal progesterone gel in a 2016 meta-analysis and a 2017 RCT.<sup>882,883</sup> Even though stopping luteal phase support after a positive pregnancy test does not seem to be associated with lower live birth rates,<sup>884,885,886</sup> 72% of ART clinics continue luteal support until 8–10 gestational weeks worldwide.<sup>887</sup> Supplemental natural progesterone is not associated with any increased risks of birth defects.<sup>880</sup> Although supplemental estradiol also is commonly administered, there is no evidence that it improves outcomes, compared to those achieved with progesterone

supplementation alone. [884,888,889](#)

# EMBRYO CRYOPRESERVATION

---

The first pregnancy resulting from transfer of a cryopreserved human embryo was reported in 1983.<sup>890</sup> In the years since, advances in cryobiology have made embryo cryopreservation an integral part of modern ART. Success with FET cycles significantly increases the overall cumulative pregnancy rate per retrieval. In addition, elective cryopreservation of all embryos may be an effective management strategy, to prevent OHSS in women with an excessive ovarian response to stimulation and to avoid decreased live birth rates with fresh transfer in this scenario.<sup>406,410,411,412,891,892</sup>

The cryopreservation process has two distinct stages, freezing and thawing. The objective of freezing is to avoid ice crystallization of intracellular water, which can result in cellular damage. Freezing protocols vary with the stage of embryo development, which affects cellular permeability. There are two basic methods for embryo cryopreservation, the “slow-freeze” technique and “vitrification.” In both, cellular water is gradually replaced by cryoprotectants (dimethyl sulfoxide, propanediol glycerol) via osmosis by passage through increasing concentrations of the cryopreservative. In the slow-freeze method, embryos are sealed in ampules or vials, cooled to temperatures between  $-30^{\circ}\text{C}$  and  $-110^{\circ}\text{C}$  in a programmed two-step process, and then stored in liquid nitrogen. The first phase of the freezing process is rapid to prevent ice crystal formation (more likely to occur with gradual cooling), and the second phase more gradual. In the vitrification method, embryos are flash frozen by immersion into liquid nitrogen, creating a solid glass-like state.<sup>893,894</sup> After thawing, the process is reversed, gradually passing the embryo through decreasing concentrations of the cryoprotectant, followed by an interval of culture before transfer.

Embryos can be frozen at any stage, from zygote to blastocyst, and remain viable for at least several years, perhaps indefinitely.<sup>895</sup> Numerous studies have compared embryo thaw survival, implantation, and pregnancy rates among embryos frozen at different stages of development. In general, postthaw survival rates after slow freezing range between 50% and 90% and are higher for zygotes than for cleavage-stage embryos and blastocysts.<sup>896,897,898,899,900,901</sup> Implantation rates (5–15%) and pregnancy rates (10–30%) after transfer of slow-frozen-thawed zygotes, cleavage-stage embryos, and blastocysts have varied among studies, but not dramatically. In contrast to slow freezing, vitrification allows rapid cooling of the cells and the extracellular milieu into a glass-like state without ice crystal formation. This is achieved by high initial concentrations of cryoprotectants, low volumes and ultrarapid cooling-warming rates. Vitrification is associated with consistently high survival rates (90–100%) and yields higher implantation and pregnancy rates.<sup>893,894,902,903</sup>

**Despite of the fact that the highest quality embryos are generally selected for**

**fresh transfer, the overall success rates for vitrified embryo transfer cycles are approximately still the same as those observed in fresh transfer cycles.** Results achieved with embryos derived from conventional IVF and ICSI are comparable. Embryos that resume cleavage and survive longer in culture are more likely to result in pregnancy, and cryopreserved sibling embryos derived from successful cycles yield higher success rates than those derived from unsuccessful cycles, probably reflecting overall better embryo quality.

Frozen-thawed embryos can be transferred in a monitored natural cycle in women with normal ovulatory function. Alternatively, transfer can occur in an artificial cycle in which endometrial development is carefully controlled by programmed sequential treatment with exogenous estrogen (oral micronized estradiol 4–6 mg daily or transdermal estradiol 0.2–0.4 mg) beginning with or shortly before the onset of menses, followed by progesterone (50–100 mg daily intramuscularly or 8% vaginal gel administered twice daily).<sup>904,905</sup> Preliminary down-regulation with a GnRH agonist also can be used, as is typical in donor oocyte recipients.<sup>303,906,907,908</sup> A 2017 systematic review including 18 randomized trials comparing different endometrial preparation regimens found no evidence that one method of endometrial preparation was superior to others.<sup>909</sup> In both natural (days after ovulation) and artificial cycles (days of progesterone treatment), the time of transfer is synchronized with the stage of embryo development, as in donor oocyte recipients (discussed below). Based on two retrospective studies, the interval between egg retrieval and FET does not seem to affect clinical outcome, and it is not required to wait for at least one menstrual cycle for the transfer of cryopreserved embryos.<sup>910,911</sup>

# OUTCOMES OF IVF

---

IVF outcomes have improved steadily throughout the years since its introduction into clinical practice. Early on, IVF offered only a modest chance for success and was reserved appropriately for couples who had no option or had failed all other available forms of treatment. As technology and outcomes improved, IVF became a realistic and attractive option for an increasing number of couples. The advent of ICSI revolutionized the treatment of severe male factor infertility and greatly contributed to the growth of ART. Now, ART often is the first and best option for a large proportion of infertile couples.

IVF success rates may be expressed in several ways, using different numerators and denominators. The two most common numerators are pregnancy and live birth, the latter being the most relevant measure. **Approximately 16% of pregnancies result in miscarriage, induced abortion (1.0%), stillbirth (0.7%), or an ectopic pregnancy (0.5%).**<sup>5</sup> Pregnancy or live birth rates may be calculated as a percentage of cycle starts, retrievals, or transfers. Overall, approximately 11% of cycles are discontinued before retrieval, due to an inadequate (82.3%) or excessive response (4.2%) to stimulation, a concurrent medical illness (0.9%), or a patient's own personal reasons (12.5%).<sup>5</sup>

For the year 2015, the U.S. registry recorded a total of 231,936 cycles of ART nationwide. Among these, 91,090 (39.3%) were IVF cycles involving fresh, nondonor oocytes (69% with ICSI), with 29.3% resulting in a pregnancy. The live birth rates were 23.9% per cycle, 26.9% per retrieval, and 36.7% per transfer. Another 69,882 (30.1%) were frozen nondonor embryo transfer cycles, yielding a live birth rate of 44.3% per transfer. Results vary considerably by age. In almost all age groups, success rates were higher for women with a previous live birth and those in their first ART cycle than for nulliparous women and those with a previous failed ART cycle.<sup>5</sup>

# Multiple Gestation

Following the introduction of ART into medical practice, there has been a substantial increase in multiple gestations. In 1998, 2 per 1,000 live births were triplet and higher-order multiple births, representing a more than 6.7-fold increase since 1971. Fertility treatments were responsible for more than 80% of these triplet and higher-order births, and half of these were the result of IVF treatment.<sup>912</sup> While the proportion of high-order multiple deliveries has significantly declined since 1998 due to a trend toward reduction in embryo transfer order, twin rates remain high. In 2015, 22.7% and 16.8% of all births in the United States resulting from fresh and FETs, respectively, were multiples, a rate 5–7 times higher than the 3% multiple-infant birth rate in the general population; 22.1% of live births after fresh nondonor embryo transfers were twins and 0.6% were triplets or more.<sup>5</sup> The higher maternal and neonatal risks associated with multiple pregnancies, their greater financial and social costs, and the many different factors that contribute to the high incidence of multiple births are reviewed in detail in [Chapter 27](#). Consequently, discussion here is limited to issues specifically relating to multiple gestations that result from ART.

**Success rates increase with the number of embryos transferred, to a point, beyond which only the multiple pregnancy rate further increases.**<sup>860,861</sup> The number of embryos corresponding to that threshold generally defines the maximum number of embryos that should be transferred. As reflected in the 2017 revised SART/ASRM embryo transfer guidelines outlined above, that number increases as age increases. Based on data from the 2015 national summary of ART results,<sup>5</sup> when one embryo is transferred, 97.9% of resulting births are singletons. When two embryos are transferred, 65.7% are singletons, 33.6% are twins, and 0.6% are high-order multiple births (triplets or more). When three embryos are transferred, 75% of births are singletons, 22% are twins, and 3% are triplets or more; the distribution of singleton, twin, and high-order multiple births does not change further with transfer of four or more embryos. Importantly, the percentage of transfers resulting in the live birth of a term singleton baby at normal weight decreases linearly with the number of embryos transferred; it is 30.3% after the transfer of a single embryo, 22.4% after two, 15.3% after three, and 10.7% after four embryos based on the 2015 records.<sup>5</sup>

Female age and the number of embryos generated and available for transfer are almost, if not just as important for predicting success as the number of embryos transferred.<sup>885,886,913</sup> Younger women tend to have both higher success rates and higher multiple-infant birth rates. Data from the 2015 U.S. national ART summary illustrate the point ([Table 28.3](#)).

Some have argued that extended culture to the blastocyst stage facilitates selection



of the highest quality embryos having the greatest implantation and developmental potential and thereby reduces both the number of embryos needed to maximize success rates and the risk for multiple birth. In 2015, 58.9% of all transfers occurred on day 5 or 6 after fertilization (blastocysts). For all age groups, the live birth per transfer rate for blastocysts was higher than for cleavage-stage embryos; the absolute differences ranged from 2.7% to 15.4% and were greatest for women under age 35 (50.3% vs. 34.9%) and smallest for those over age 44 (3.2% vs. 0.5%).<sup>5</sup> However, despite a higher percentage of single-embryo transfers (38.6% vs. 20.1%), and a lower percentage of  $\geq 3$  embryo transfers (6.9% vs. 28.7%) on day 5 versus day 3, the proportion of double (2) embryo transfers was quite similar (54.6% vs. 51.2%) between day 5 and day 3. Consequently, 23.7% of live births resulting from day 5 transfers were multiples (23.1% twins, 0.6% triplets and more), compared to 20.8% of day 3 transfers (20.0% twins, 0.8% triplets and more).<sup>5</sup> When two blastocysts are transferred, the incidence of high-order multiple gestation is markedly reduced but not altogether eliminated, because the incidence of monozygotic twinning may be increased after blastocyst transfer,<sup>914</sup> and the incidence of twins is no lower than that associated with transfer of greater numbers of cleavage-stage embryos.<sup>687,689</sup>

As previously discussed, the SART/ASRM guidelines on the number of embryos transferred have been revised several times since first issued in 1998, in efforts to reduce the incidence of multiple pregnancy, high-order multiple pregnancy in particular. The average numbers of embryos transferred in the United States began decreasing in 1997, with the steepest decline observed between 1998 and 1999 after the first guidelines were issued. Whereas the number of pregnancies and live births per cycle has increased steadily, the percentage of high-order multiple pregnancies has decreased, with the steepest decline (20.8%) again occurring between 1998 and 1999.<sup>915</sup> Unfortunately, the percentage of twin pregnancies has remained at a relatively high level.

# Offspring of IVF

Studies of the offspring resulting from IVF have raised concerns that the children may be at increased risk for prematurity, low birth weight, birth defects, genetic and epigenetic abnormalities, vascular and metabolic abnormalities, delayed neurologic development, and cancer.

## Preterm Birth and Low Birth Weight

As previously discussed, ART is associated with increased incidence of multiple pregnancy, which, in turn, is associated with increased incidence of preterm birth and low birth weight. Therefore, to better assess the impact of ART itself on these parameters, one should compare the outcomes of singleton pregnancies. In a 2012 systematic review including 28,000 ART compared with non-ART singletons, the relative risks for preterm delivery less than 37 weeks and less than 32 weeks were 1.54 (95% CI = 1.47–1.62) and 1.68 (95% CI = 1.48–1.91), respectively. The findings for low birth weight (LBW, <2,500 g) and very low birth weight (VLBW, <1,500 g) were also increased with odds ratios of 1.65 (95% CI = 1.56–1.75) and 1.93 (95% CI = 1.72–2.17), respectively. The risk for small for gestational age (SGA) was also increased by 40% in ART babies (OR = 1.39, 95% CI = 1.27–1.52).<sup>916</sup> The risks of preterm delivery and low birth weight are declining over time.<sup>916,917,918,919,920,921</sup> An analysis of data from more than 92,000 ART infants born in Denmark, Finland, Norway, and Sweden confirmed both the increased risk and the improvement in the perinatal outcomes of singleton ART children.<sup>922</sup> The adjusted odds ratios in singletons for preterm birth (PB) less than 37 weeks, PB less than 32 weeks, LBW less than 2,500 g, VLBW less than 1,500 g, and finally SGA were found to be 2.47, 3.80, 2.94, 4.77, and 1.83, respectively, in the analysis for 1988–1992, whereas the odds ratios for the 2003–2007 period were considerably lower at 1.50, 2.06, 1.49, 2.11, and 1.13, respectively. The preterm birth and LBW risks were similar in ART and spontaneously conceived twins, and the risks did not change significantly over time.<sup>922</sup>

ART singleton pregnancies were also associated with a higher risk of antepartum hemorrhage (OR = 2.49, 95% CI = 2.30–2.69), hypertensive disorders of pregnancy (OR = 1.49, 95% CI = 1.39–1.59), gestational diabetes (OR = 1.48, 95% CI = 1.33–1.66), preterm rupture of membranes (OR = 1.16, 95% CI = 1.07–1.26), caesarean section (OR = 1.56, 95% CI = 1.51–1.60), and induction of labor (OR = 1.18, 95% CI = 1.10–1.28) compared to spontaneously conceived singletons.<sup>909</sup> Increased rate of pregnancy complications such as antepartum hemorrhage, placenta previa, and hypertensive disorders of pregnancy, along with more precautionous antenatal care of ART pregnancies, may be at least partly responsible for the higher rate of preterm birth.

The risk of stillbirth between 22nd and 28th gestational weeks is increased by twofolds (95% CI = 1.55–2.78) for ART singletons compared to those spontaneously conceived.<sup>923</sup> However, the risk of stillbirth seems similar after the 28th gestational week. The ART twins have a lower risk of stillbirth compared to spontaneously conceived twins; however, when only dizygotic twins are considered, the risk seems similar in the two groups. The risk of early neonatal and infant deaths for ART singletons and twins seems similar with spontaneously conceived singletons and twins.<sup>923</sup>

Parental characteristics in couples with infertility may contribute to the poorer perinatal outcome. In a 2013 meta-analysis of 14 studies comparing the perinatal outcomes of pregnancies conceived without treatment after a long time to pregnancy interval with pregnancies conceived within 12 months of attempting pregnancy, they found that the risks of preterm delivery (adjusted OR = 1.31, 95% CI = 1.21–1.42), LBW (adjusted OR = 1.34, 95% CI = 1.21–1.48), and SGA (adjusted OR = 1.17, 95% CI = 1.03–1.33) were increased in women with a long time to pregnancy interval.<sup>924</sup> A study comparing the perinatal outcomes of women treated with ART, women with subfertility but spontaneous pregnancies, and fertile women in a total of 334,628 births and fetal deaths in Massachusetts revealed that the risks for both preterm birth and low birth weight were significantly higher for the ART group (adjusted ORs and CIs: OR = 1.23, 95% CI = 1.08–1.41, and OR = 1.26, 95% CI = 1.08–1.47, respectively) compared with the subfertile group and risks in both the ART and the subfertile groups were higher than those among the fertile group (adjusted ORs and CIs: OR = 1.53, 95% CI = 1.40–1.67 and OR = 1.51, 95% CI = 1.37–1.67 for the ART group, and OR = 1.24, 95% CI = 1.12–1.38 and OR = 1.20, 95% CI = 1.06–1.36 for the subfertile group, respectively).<sup>925</sup> There were no significant differences between the three groups for SGA in this study. These results indicate that subfertility itself may be partly responsible for the poorer perinatal outcome.

Some of the increased risk may be attributable to the endometrial environment. The stimulation associated with ART may impair implantation. The risk of preterm birth was found to be similar between singletons from FET and spontaneous conceptions, whereas the risk was lower compared to ART singletons from fresh embryo transfers (adjusted OR = 0.85, 95% CI = 0.76–0.94; frozen vs. fresh embryo transfer).<sup>926</sup> Furthermore, the risk of preterm birth in singletons with a ‘vanishing co-twin’ was significantly increased compared to a single gestation (adjusted OR = 1.73, 95% CI 1.54–1.94).<sup>919</sup> Concerning number of embryos transferred, meta-analysis of three studies revealed that the risk of preterm birth was similar for singletons from single embryo transfer and those from double embryo transfer (adjusted OR = 0.83, 95% CI 0.64–1.06,  $p = 0.21$ ),<sup>926</sup> while another study utilizing publicly available data from 5 states found that singletons born

following single embryo transfer had equivalent obstetric outcomes to non-ART singletons; however, the singletons following double embryo transfer were more likely to be preterm <37 weeks and <32 weeks, and have LBW or VLBW.<sup>929</sup>

In a population-based retrospective registry study comparing neonatal and maternal outcome after 4,819 blastocyst transfers with 25,747 cleavage-stage transfers and 1,196,394 spontaneous conceptions, perinatal mortality and the risk of placental complications were significantly higher in the blastocyst transfer compared to the cleavage-stage transfer group (adjusted OR = 1.61, 95% CI = 1.14–2.29, for perinatal mortality, and adjusted OR = 2.08, 95% CI = 1.70–2.55 and adjusted OR = 1.62, 95% CI = 1.15–2.29 for placenta previa and placental abruption, respectively).<sup>927</sup> The risks for placenta previa and placental abruption were also significantly increased in the blastocyst transfer group compared to spontaneous conceptions (adjusted OR = 6.38, 95% CI = 5.31–7.66 and adjusted OR = 2.31, 95% CI = 1.70–3.13, respectively).

## Large-for-Gestational Age Babies

Singletons conceived after FET have an increased risk of being LGA, and having macrosomia, defined as a birth weight greater than 4,500 g.<sup>928,929,930</sup> A Nordic study compared the perinatal outcomes of 6,647 singletons conceived after FET with 42,242 singletons conceived after fresh embryo transfer and 288,542 spontaneously conceived singletons found significantly increased risks of both LGA and macrosomia in the FET group. The adjusted ORs for LGA and macrosomia were 1.45 (95% CI = 1.27–1.64) and 1.58 (95% CI = 1.39–1.80), respectively, compared to the fresh embryo transfer group and 1.29 (95% CI = 1.15–1.45) and 1.29 (95% CI = 1.15–1.45), respectively, compared to spontaneously conceived children.<sup>930</sup> Similarly, a meta-analysis of three national registry-based cohort studies revealed significantly higher risk of LGA and macrosomia in both FET versus fresh singletons and FET versus natural conceptions.<sup>929</sup> In another analysis that aimed to distinguish the intrinsic maternal factors from those related to the freezing and thawing processes, the prevalence of LGA was compared in consecutive sibling pairs, where one sibling was born after FET and the other after fresh embryo transfer. The first sibling group consisted of 550 singletons with the first sibling born after fresh embryo transfer and the second one after FET, whereas the second sibling group consisted of 116 singletons with the first sibling born after FET and the second sibling after fresh embryo transfer. In the cohort with the first child born after fresh embryo transfer, the risk of LGA in the FET sibling was significantly higher with an adjusted OR of 3.45 (95% CI = 1.33–8.33). In the latter cohort with the first sibling born after FET, the risk of LGA was also increased albeit lower than the first cohort. The risk remained increased after adjustment for parity and birth order in the complete sibling cohort, indicating the contribution of the freezing and thawing

procedures per se.<sup>929</sup> With increasing reliance on cryopreserved embryo transfers and improving laboratory conditions, large prospective studies are awaited to determine the impact of embryo cryopreservation on birth weight.

## Congenital Anomalies

The risk of birth defects in ART babies has been the subject of many studies albeit with several shortcomings. These limitations include different definitions of major malformations, time and extent of evaluation for birth defects and the duration of follow-up, inclusion of pregnancies terminated for fetal malformations and stillbirths, use of inappropriate control groups (e.g., spontaneous conceptions in normal vs. subfertile couples), and diversity of ART techniques (IVF vs. ICSI, fresh vs. FET, cleavage vs. blastocyst transfer, hatching, etc.) used.<sup>931,932</sup>

Several meta-analyses revealed a 30–40% increase in relative risk of birth defects in singleton and multiple ART pregnancies combined, compared to spontaneous conceptions.<sup>916,920,931,933,934,935,936</sup> A 2012 systematic review including 46 studies with 124,468 children conceived by ART compared to spontaneously conceived children showed a significantly increased risk of birth defects (RR = 1.37, 95% CI = 1.26–1.48) in the former. When IVF and ICSI pregnancies were compared separately to spontaneous conceptions, the RR of birth defects was higher for ICSI children than IVF children (1.58 vs. 1.30, respectively); however, the difference between the two groups was not statistically significant ( $p = 0.11$ ). Furthermore, analysis of 24 studies that compared 46,890 IVF babies with 27,754 ICSI babies revealed no significant difference in risk of birth defects (RR = 1.05, 95% CI = 0.91–1.20).<sup>936</sup> A 2013 meta-analysis confirmed the former and the risk ratio for birth defects was found to be 1.32 (95% CI = 1.24–1.42) in 92,671 ART children. The risk was further increased (RR = 1.42, 95% CI = 1.29–1.56) when studies evaluating only major malformations were analyzed. Additionally, the RR for singleton ART pregnancies was 1.36 (95% CI = 1.30–1.43) whereas analysis of studies in ART twin pregnancies adjusted for distribution of zygosity revealed a pooled risk of 1.26 (95% CI = 0.99–1.60) compared to non-ART twins.<sup>934</sup> Similar to the results of the 2012 study, there was no significant difference in the pooled risk estimates in ICSI versus non-ART children (RR = 1.37) compared to IVF versus non-ART children (RR = 1.36).<sup>934</sup>

In a recent and large registry-based study comparing the prevalence of birth defects among 64,861 live born infants conceived using ART with 4,553,215 non-ART infants including singleton and multiple pregnancies, the adjusted RR for nonchromosomal birth defects was 1.28 (95% CI = 1.15–1.42).<sup>937</sup> Furthermore, tracheoesophageal fistula/esophageal atresia (aRR = 1.93, 95% CI = 1.40–2.67), rectal and large intestinal atresia/stenosis (aRR = 2.03, 95% CI = 1.51–2.74), and reduction deformity of the

lower limbs (aRR = 2.18, 95% CI = 1.39–3.43) were significantly increased with ART use. Similarly, regarding singleton live born infants only, the adjusted RR for nonchromosomal birth defects was found to be 1.39 (95% CI = 1.21–1.59), and the risks for tracheoesophageal fistula/esophageal atresia (aRR = 1.90, 95% CI = 1.23–2.94) and rectal and large intestinal atresia/stenosis (aRR = 1.88, 95% CI = 1.26–2.82) were significantly higher for ART versus non-ART infants. **Both earlier and more recent meta-analyses suggest a 30–40% relative increased risk of birth defects in ART children, from a baseline of 2–3% to 2.7–4%.**<sup>934,938,939</sup>

However, similar to the data on obstetric risk, it is unclear if it is the actual exposure to ovarian hyperstimulation/embryo culture or the underlying infertility that is the primary driver of this effect. A large registry-based observational Australian study of approximately 310,000 deliveries compared the risk of birth defects in spontaneous conceptions, ART infants, spontaneous pregnancies in women who had a previous birth with ART, and spontaneous pregnancies in women with infertility. Mothers in the assisted conception group were older and were more likely to be nulliparous, white, and of higher socioeconomic status. After multivariate adjustment, the increased risk for birth defects in the IVF/ICSI combined group (adjusted OR = 1.24, 95% CI = 1.09–1.41) and the ICSI group (adjusted OR = 1.57, 95% CI = 1.30–1.90) remained significant, whereas the increased risk for the IVF group (adjusted OR = 1.07, 95% CI = 0.90–1.26) was no longer significant. Regarding risks of other types of assisted conception compared to spontaneous conceptions, gamete intrafallopian transfer, intrauterine insemination, and the use of clomiphene citrate at home were associated with significantly increased risk of birth defects, whereas clinically supervised ovulation induction, low-dose hormonal stimulation, timed intercourse, and donor insemination were not. Furthermore, adjusted risk of birth defects showed a 25% relative increase in spontaneously conceived children of women who have had a previous ART pregnancy (adjusted OR = 1.25, 95% CI = 1.01–1.56). Borderline increased risk of birth defects was also observed in spontaneously conceived children of women with a history of infertility (OR = 1.29, 95% CI = 0.99–1.68).<sup>940</sup> Another study comparing the prevalence of birth defects in the Danish national birth registry between fertile couples (time to pregnancy  $\leq$ 12 months) and those who conceived spontaneously after 12 months addressed the effect of subfertility per se.<sup>941</sup> The risk for malformations was increased in the latter group (OR = 1.20, 95% CI = 1.07–1.35), and the overall prevalence of congenital malformations increased with increasing time to pregnancy. A meta-analysis calculated that subfertility was responsible for about 40% of the increased risk of birth defects associated with ART and reported an adjusted overall odds ratio of 1.01 (95% CI = 0.82–1.23), indicating no significant increased risk associated with ART.<sup>942</sup>

## Chromosomal, Genetic, and Epigenetic Abnormalities

Limited evidence suggests that the prevalence of chromosomal abnormalities in children conceived with ART is not different from that in children conceived naturally. Nonetheless, concerns persist that the use of sperm from infertile men, and ICSI itself, might increase the risk for conceiving a child with a chromosomal or genetic defect, because infertile men (and women) are more likely than fertile men (and women) to have a genetic abnormality that may contribute to their infertility and that their children may inherit.

Genomic imprinting describes the process that limits expression of the imprinted gene from one parental allele (maternal or paternal). For a number of genes involved in early embryonic growth and placental and neurologic development, transcription is normally restricted to one allele. Usually, the maternal allele is active in imprinted genes involved in fetal development, and the paternal allele is active in genes involved in placental growth. Imprinting disorders can arise via several mechanisms, including mutations in an imprinted gene, uniparental disomy (both copies of a gene coming from one parent), and changes in DNA methylation. There is reason for concern that elements of ART might predispose to imprinting disorders; imprints are established during meiosis and at the time of each meiotic division in the oocyte (the first occurring at ovulation and the second at fertilization), and they are exposed to treatments and manipulations during ART. Any excess risk for imprinting disorders that might relate to ART is difficult to detect because the disorders are quite rare (1 in 12,000 births). Nonetheless, three of the nine known disorders have been linked to ART, including Beckwith-Wiedemann syndrome,<sup>705,706,707,943,944,945</sup> Angelman syndrome,<sup>704,946,947</sup> and maternal hypomethylation syndrome.<sup>712</sup> Although earlier studies suggested an increased incidence of Beckwith-Wiedemann syndrome in ART children, later cohort studies did not confirm an increased risk of imprinting disorders.<sup>709,948,949</sup> In addition, the relative risks of these syndromes were the same in subfertile women with or without ART, and thus, the increased prevalence of imprinting disorders, if any, has been attributed to subfertility rather than ART procedures themselves.<sup>950</sup> It is very challenging to estimate the impact of ART on these rare imprinting disorders, and large prospective cohort studies are needed.

## Vascular and Metabolic Abnormalities

There are a number of cohort studies suggesting that cardiovascular and general metabolic health may be mildly compromised in children conceived via ART. A comparison of 233 ART singletons with 233 spontaneously conceived children from subfertile parents, after matching for age and gender, showed that ART children had significantly more peripheral adipose tissue.<sup>951</sup> Height, weight, body mass index (BMI),

bone mineral content, bone mineral density, central fat measures, and pubertal stage were similar in both groups. Another study on the same cohort showed that ART children had significantly higher systolic and diastolic blood pressures than controls (systolic  $109 \pm 11$  vs.  $105 \pm 10$  mm Hg,  $p < 0.001$ ; diastolic  $61 \pm 7$  vs.  $59 \pm 7$  mm Hg,  $p < 0.001$ , respectively).<sup>952</sup> While fasting insulin concentrations and BMI were comparable, fasting glucose levels were significantly higher in the IVF group ( $5.0 \pm 0.4$  vs.  $4.8 \pm 0.4$  mmol/L  $p = 0.005$ ).

Another study compared 106 ART with 68 spontaneously conceived children and found that the former had significantly higher blood pressures.<sup>953</sup> BMI, fasting glucose-to-insulin ratio, high-density lipoprotein (HDL), low-density lipoprotein (LDL), uric acid, apolipoprotein-A1, apolipoprotein-B, lipoprotein(a), leptin, adiponectin, high-sensitivity C-reactive protein (hsCRP), and high-sensitivity interleukin-6 (hs IL-6) were similar in both groups; only triglyceride levels were significantly increased in the IVF group compared to controls ( $59.5 \pm 25.1$  vs.  $52.4 \pm 23.3$  mg/dL, respectively  $p = 0.031$ ). When SGA and LGA born children were analyzed separately, IVF children still had significantly higher blood pressures; however, the difference in triglyceride levels was no longer significant. A previous study of 69 ART and 71 spontaneously conceived children reported an improved lipid profile including higher HDL levels ( $1.67 \pm 0.04$  mmol/L vs.  $1.53 \pm 0.04$  mmol/L,  $p = 0.02$ ) and lower triglyceride levels ( $0.65 \pm 0.04$  mmol/L vs.  $0.78 \pm 0.04$  mmol/L,  $p = 0.02$ ) in IVF children.<sup>954</sup>

Systemic and pulmonary vascular functions of 65 ART and 57 spontaneously conceived children were compared, and BMI, systolic and diastolic blood pressures, glucose and insulin levels, HOMA, LDL, HDL, and triglyceride levels were similar.<sup>955</sup> However, there were concerns raised over endothelial cell function and risk for atherosclerosis; flow-mediated dilation of the brachial artery was approximately 25% less ( $p < 0.0001$ ), pulse wave velocity was significantly faster ( $p < 0.001$ ), and carotid intima-media thickness was significantly greater in ART children ( $p < 0.0001$ ). Similarly, when the subjects were taken to a higher altitude and pulmonary artery pressure was measured by Doppler echocardiography, ART children had 30% higher systolic pulmonary artery pressure ( $p < 0.0001$ ).

While metabolic effects of ART are not well established, some studies indicate that ART may have an unfavorable effect on the vascular system. However, the differences observed are inconsistent between studies, quite small for each parameter, and of unknown biologic significance. The long-term consequences, if there are any, of these initial findings are to be determined in subsequent studies.

## **Behavioral and Cognitive Aspects**

Multiple studies have examined whether children conceived via IVF were at greater



risk of psychomotor delay, altered socialization, or emotional problems. A 2009 study compared behavioral and socioemotional functions of 139 children born after IVF with 143 children conceived spontaneously by subfertile couples.<sup>956,957</sup> The results were corrected for parity, birth weight, prematurity, gestational age, and mother's educational level. ART children had significantly fewer externalization problems, thought and attention problems, and aggressive behavior. A 2011 study using the same cohort showed that ART children scored comparably in total problem scale, internalizing, anxious/depressed behavior, somatic complaints, social problems, thought problems, attention problems, aggressive behavior, and rule-breaking behavior with spontaneously conceived children.<sup>957</sup> Moreover, there were no differences in externalization and withdrawn/depressed behavior between the two groups. These findings suggest that ART does not seem to cause any behavioral effects in adolescents. A 2001 study compared socioemotional functions of 38 spontaneously conceived children, 49 adopted children, and 34 ART children with a mean age of 11, using interviews and a number of standardized questionnaires that were filled by children, their parents, and teachers.<sup>958</sup> Likewise, ART children were found to have similar social and emotional functions when compared with the other groups. **Overall, ART children seem to have normal social and emotional functions, at least in early life.**

A study comparing information processing, attention, and visual-motor function in children conceived spontaneously and by ART reported similar general cognitive ability, information processing, and attention (speed, accuracy and sustainability of attention, capacity of mental shifting, memory) in both groups.<sup>959</sup> While ART group scored significantly lower in motor speed and motor coordination, the results were still within the normal range. Similar intelligence quotient (IQ), visual-motor coordination, visual memory, and verbal comprehension abilities are reported in 51 IVF children and 51 control children.<sup>960</sup> Cognitive development of 86 ICSI, 83 IVF, and 85 natural conceptions reported a crude difference in IQ was 3.9 (95% CI = -0.7 and 8.4) between ICSI and IVF children and 6.8 (95% CI = 2.0 and 11.6) between ICSI and natural conception children. The above notwithstanding, mean IQ was within the normal range in all groups.<sup>961</sup>

**Assessing neurocognitive outcomes for ART has methodologic challenges such as lack of blinding, being underpowered, using nonstandardized assessment tools, low participation rates, and selection bias.<sup>962</sup> Still, available evidence suggests cognitive and motor functions are not affected by method of conception.**

## Cancer

Another concern about ART is its possible association with childhood cancers. Many

studies have been conducted to determine whether offspring born following ART treatment have an increased risk of developing various cancers.

A 2013 meta-analysis of 25 studies showed an increased risk (RR 1.42, 95% CI = 0.96–1.8).<sup>963</sup> Only 2 of the 25 studies in the meta-analysis included untreated subfertile controls; neither of these studies identified a link between ART and cancer risk. In the same year, a large British study included 106,103 ART children born from 83,967 pregnancies between 1992 and 2008 and identified 108 children diagnosed with cancer. Expected number of cancer cases was 109.7 for the same cohort, resulting in a standardized incidence ratio of 0.98 (95% CI = 0.81 and 1.19) for the study group.<sup>964</sup> A more recent large population study in 2014 included ART babies born between 1982 and 2007 in Sweden, Denmark, Finland, and Norway.<sup>965</sup> A total of 91,796 ART children were compared with 358,419 spontaneously conceived children. After adjusting for country, maternal age, parity, gender, gestational age, birth defects, and chromosomal defects, hazard ratio for cancer in ART children was not significant: 1.08 (95% CI = 0.91–1.27). While 2 in 1,000 children were diagnosed with cancer in the ART group, this rate was 1.8 in 1,000 spontaneously conceived children. Risks for two cancer types were significantly increased in ART children, central nervous system tumors (adjusted HR = 1.44, 95% CI = 1.01–2.05), and malignant epithelial neoplasms (adjusted HR = 2.03, 95% CI = 1.06–3.89). However, the authors underline that this contributes very little to the absolute risk for these cancers, and overall patients can be reassured about safety of ART procedures. **In conclusion, although some studies inconsistently show increased risk for certain cancer types, ART children do not seem to be at significant risk for childhood cancers.**

## Key Points

- Concerns about the health and welfare of children born after ART are reasonable and understandable.
- The available data indicate that ART is associated with an increased risk of multiple gestation, congenital anomalies, preterm delivery, low birth weight, and the complications associated with these outcomes.
- The concerns are justified but are not cause for undue alarm. Children born from ART are generally healthy.

# OOCYTE DONATION

---

Until approximately 25 years ago, women with ovarian failure were understandably considered irreversibly sterile, but advances in ART have changed that view. Oocyte donation now offers women with premature ovarian insufficiency, premature reproductive aging, and surgical removal of the ovaries and even women beyond their normal reproductive years a very realistic chance for pregnancy.

A successful pregnancy established in one woman (the recipient) using oocytes from another (the donor) was first reported in 1983. The original technique involved intracervical artificial insemination of a normal volunteer with sperm from the male partner of an infertile woman, uterine lavage during the preimplantation interval, and transfer of the recovered embryo to the uterus of the infertile female partner who received a programmed regimen of hormone replacement designed to synchronize endometrial and embryo development.<sup>966</sup> Numerous ethical and technical problems prevented wide application. That same year saw the first report of a pregnancy established by ovum donation, IVF, and transfer to a cycling recipient.<sup>967</sup> Within another year, the first successful pregnancy resulting from oocyte donation and IVF in a woman with ovarian failure was reported.<sup>968</sup> The U.S. national ART registry recorded 21,182 oocyte donation cycles in 2015.<sup>5</sup>

Oocyte donation is now commonly achieved by IVF using oocytes retrieved from healthy young donors after controlled ovarian hyperstimulation and the sperm of the recipient's partner, with the resulting embryos then transferred to the uterus of the recipient.<sup>969</sup> Success with donor oocytes also has been achieved using tubal transfer techniques. Although straightforward in concept, the requirements for successful ovum donation IVF are many and complicated. The unique and key features of a donor oocyte IVF cycle relate to the need for embryo/endometrial synchronization and exogenous hormonal support of early pregnancy until the luteal-placental shift. Other important issues relate to donor recruitment, selection, and screening.

# Indications

There are a number of accepted indications for ovum donation IVF—ovarian failure, genetically transmitted disease, declining or absent ovarian function, advanced reproductive age, and persistent poor oocyte quality in IVF cycles.<sup>970</sup> Women with ovarian failure from any cause (X chromosome abnormalities; idiopathic gonadal dysgenesis or premature oocyte depletion; previous surgery, irradiation, or chemotherapy; autoimmune disease) are candidates. Also included are women who carry specific heritable disorders not amenable to PGD or who reject PGD and women with a DOR due to age or other causes who have a poor prognosis for successful IVF using their own oocytes. Oocyte donation is also an option for male same-sex couples who choose parenthood through assisted reproduction.

# Donor Oocyte Recipients

With a few exceptions, the pretreatment evaluation and screening of couples seeking oocyte donation are virtually identical to that recommended before conventional IVF. Psychological counseling is an important element of the evaluation and helps to identify couples with unresolved concerns or fears and to ensure that both partners are fully committed to the effort.

Women with Turner syndrome may be considered candidates for ovum donation and deserve specific mention. **Evidence indicates that pregnancy may pose unique and serious risks for women with Turner syndrome, who often have cardiovascular malformations involving the aortic root.** Like women with Marfan syndrome, women with Turner syndrome are at increased risk for aortic dissection during pregnancy, presumably relating to the increased cardiovascular demands. **The maternal risk of death from rupture or dissection of the aorta in pregnancy may be 2% or higher.**<sup>971</sup> Women with Turner syndrome expressing interest in oocyte donation should be carefully evaluated, to include echocardiography or magnetic resonance imaging, with any significant abnormality best regarded as a contraindication to oocyte donation. In general, even women with normal evaluations should be discouraged, because aortic dissection still may occur. Those who choose to proceed require careful observation and frequent reevaluation during pregnancy.<sup>972</sup>

## Controlled Endometrial Development

In spontaneous cycles, endometrial proliferation and secretory maturation are driven by sex steroid production associated with follicular growth, ovulation, and luteal function; development of the endometrium and the embryo is naturally synchronized. In ovum donation cycles, that same careful synchronization must be orchestrated. The “window of endometrial receptivity,” the interval during which implantation normally occurs, is relatively narrow and spans approximately 3 days, perhaps as much as 5 days.<sup>973,974</sup> The opening and duration of the implantation window are controlled primarily by the duration of progesterone exposure. The length of the preceding proliferative phase is extremely flexible and can vary widely,<sup>973</sup> as occurs naturally in oligo-ovulatory women.

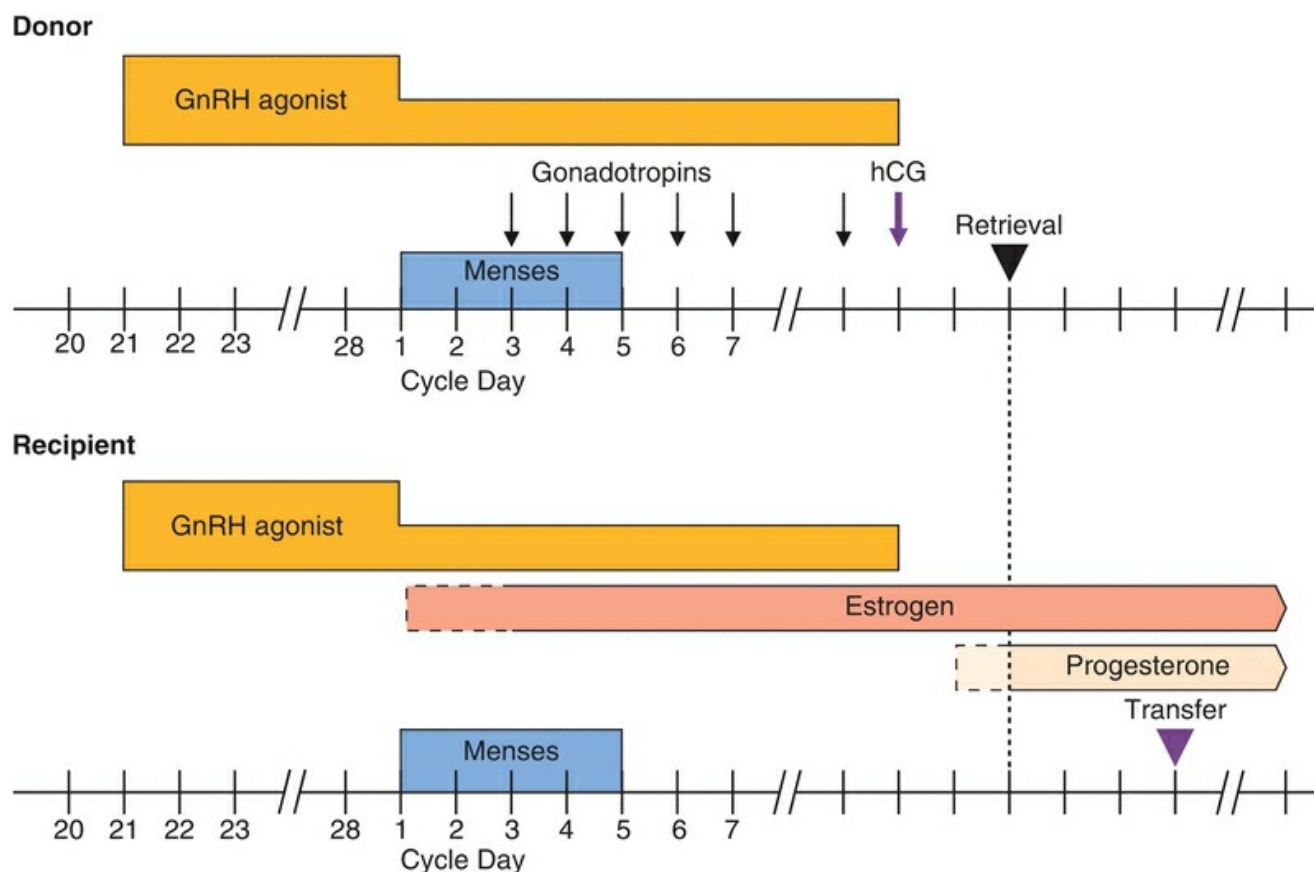
To synchronize endometrial development with the embryos to be transferred, recipients with functioning ovaries are first down-regulated with a long-acting GnRH agonist, treatment that women with ovarian failure obviously do not require. In either case, a programmed regimen of sequential estrogen and progesterone replacement is used to simulate the natural cycle and to promote normal endometrial growth and maturation, the same way as in FET cycles (discussed above). A wide variety of

treatment regimens have been used successfully to achieve controlled endometrial development and maturation.

Estrogen can be administered orally (micronized estradiol 4–6 mg daily) or transdermally (estradiol 0.2–0.4 mg daily). Both routes of administration are effective and neither has proven superior, despite the widely varying serum estradiol levels that can result.<sup>124,975,976,977,978</sup> Oral and transdermal estrogen treatment regimens are designed to achieve serum levels that approximate those observed in the late follicular phase in natural cycles (200–400 pg/mL); equivalent doses of vaginal estrogen achieve markedly higher serum and tissue concentrations.<sup>979</sup> The duration of estrogen therapy is quite flexible and can range from as short as 7 days to as long as 3 weeks or more.<sup>976</sup> Progesterone can be administered intramuscularly, in doses designed to achieve serum concentrations approximating 20 ng/mL (50–100 mg daily),<sup>980,981</sup> and/or vaginally, in the form of suppositories, tablets, or gel (180–600 mg daily). Intramuscular administration yields substantially higher serum concentrations, but endometrial tissue levels are highest after vaginal treatment.<sup>975</sup>

The methods and extent of monitoring vary widely among programs. Many use transvaginal ultrasonographic measurements of endometrial thickness, aiming to achieve a thickness greater than a minimum of 6–7 mm.<sup>362,386,982,983</sup>

To maximize the probability for successful implantation, embryo transfer must be carefully timed. To achieve the same coordination of embryo and endometrial development that occurs in natural conception cycles, progesterone treatment in the recipient should begin on the day the donor undergoes retrieval.<sup>881</sup> Day 2 embryos (2 days after retrieval and fertilization) are transferred on the 3rd day of progesterone therapy, day 3 embryos on the 4th day, and day 5 embryos on the 6th day.<sup>124</sup> Although the effective “transfer window” is wider than a single day, synchronous transfer provides a margin of safety and compensates for any minor variations in the speed of endometrial maturation. Flexibility in the duration of preliminary estrogen treatment in the recipient facilitates convenient scheduling. In general, estrogen therapy begins at 2 days before the time that stimulation begins in the donor, allowing ample time to achieve the desired degree of endometrial proliferation before the donor’s retrieval (**Figure 28.7**).



**FIGURE 28.7**

## Luteal Phase and Early Pregnancy Support

In naturally conceived early pregnancies, the rapidly rising levels of hCG first “rescue” and then stimulate the corpus luteum to maintain the high levels of estrogen and progesterone secretion necessary to ensure endometrial stability in support of early embryonic growth and development until the emerging placenta achieves the capacity to assume that responsibility. The donor oocyte recipient has no corpus luteum. Consequently, exogenous luteal support must be provided for the requisite interval. Normally, the luteal-placental transition is completed between 7 and 9 weeks of gestation (menstrual dates) or between 4 and 6 weeks after a blastocyst transfer.<sup>984</sup>

**Exogenous estrogen and progesterone treatment therefore must continue until at least 7 weeks, and many recommend treatment until approximately 10 weeks of gestation, for added safety.** Some prefer to monitor serum estradiol and progesterone concentrations during the early weeks of pregnancy, decreasing the dose of exogenous hormone treatment by half after observing a sharp rise in levels and discontinuing treatment after an additional week if concentrations continue to rise normally.

# Oocyte Donors

The limited availability of suitable oocyte donors is the greatest obstacle in maintaining an active donor oocyte program. Donors may be a known relative or acquaintance of the recipient,<sup>985</sup> but most are anonymous, young healthy volunteers recruited from the local population. In most metropolitan areas in the United States, oocyte donors are compensated for their time, inconvenience, and assumption of risk. Outside of the United States, such compensation is discouraged and, in some countries, is illegal.

The ASRM has provided detailed guidelines for the appropriate screening of candidate oocyte donors.<sup>970</sup> In brief summary, all donors should be between 21 and 34 years of age, have a thorough medical history and physical examination to exclude those at high risk for sexually transmitted infections or genetically transmissible disease, and undergo standard preconception testing. In accordance with U.S. federal law, candidate donors also must be thoroughly screened for sexually transmitted infections, including syphilis, hepatitis B (surface antigen and core antibody), hepatitis C (antibody), and HIV-1/HIV-2, using tests performed in a laboratory approved by the U.S. Food and Drug Administration (FDA) for donor screening. Screening also includes tests for gonorrhea and chlamydia, and all tests must be performed within the 30 days immediately preceding oocyte retrieval. False-positive results exclude anonymous donors and repeated testing is not permitted. Other exclusion criteria can be found in the ASRM Practice Committee Recommendations for gamete and embryo donation.<sup>970</sup> Written documentation of donor eligibility is also required. The donor should undergo appropriate genetic evaluation based on history, in accordance with ethnic background and current guidelines. Cystic fibrosis testing should be performed on all donors. Consideration should be given to fragile X and spinal muscular atrophy testing on donors, but is not required. Similarly, some programs test egg donors using expanded carrier screening for a large number of recessive disorders, although it is not required. Psychological evaluation by a qualified mental health professional is strongly recommended.<sup>970</sup>

Vitrification has greatly improved the efficiency of oocyte cryopreservation, and since 2013, the use of vitrified/warmed oocytes for fertility preservation is no longer considered experimental.<sup>127</sup> Fertilization and pregnancy rates are similar to IVF/ICSI with fresh oocytes when vitrified/warmed oocytes are used for young women. No increase in chromosomal abnormalities, birth defects, and developmental deficits has been reported in offspring born from cryopreserved oocytes when compared to pregnancies from conventional IVF/ICSI and the general population.<sup>127</sup> Egg banking simplified oocyte donation dramatically, by eliminating the need to synchronize donors and recipients, and has the added benefit of serving to decrease the number of unused



frozen embryos resulting from conventional oocyte donation cycles.

# Outcomes of Oocyte Donation

Experience with ovum donation has provided important insights into the mechanisms involved in the age-related decline in female fertility. The oocyte donation model effectively dissociates oocyte and uterine age. Success rates with conventional IVF decline steadily as age increases, most noticeably after age 35, and viable pregnancies are infrequent beyond age 42. **In contrast, the live birth rate in oocyte donation cycles varies little across all age groups.** These data demonstrate that the declining developmental potential of aging oocytes is the limiting factor.

Data from the 2015 U.S. national ART summary indicate that among 7,331 fresh donor oocyte cycles across all age groups, 55.6% of transfers resulted in a live birth, with an average of 1.6 embryos transferred. Among 12,151 transfers of frozen embryos derived from donor oocytes, 35.4% resulted in a live birth, with an average of 1.5 embryos transferred.<sup>5</sup>

Because most recipients are over age 35, their pregnancies may be considered high-risk pregnancies. Multiple pregnancies are common and are associated with well-known and specific risks. In 2015, 28.3% of pregnancies and 27.7% of live births resulting from oocyte donation were multiples.<sup>5</sup>

A 2017 systematic review and meta-analysis showed an increased risk of preterm delivery in oocyte donation pregnancies compared to nondonor oocyte pregnancies (OR = 1.45, 95% CI = 1.20–1.77). Similarly, the risk of low birth weight was higher after transfer of fresh embryos derived from donated oocytes compared to nondonor oocyte pregnancies (OR = 1.34, 95% CI = 1.12–1.60).<sup>986</sup>

Two 2016 systematic reviews showed approximately threefold increased risk of preeclampsia in oocyte donation pregnancies compared with other methods of ART or natural conception. The risk of gestational hypertension was also increased significantly in oocyte donation pregnancies in comparison with other methods of ART or natural conception. The risks for preeclampsia and gestational hypertension were similarly increased in singleton and multiple gestations from donor oocytes.<sup>987,988</sup>

# Gestational Surrogacy

Gestational surrogacy offers women without a functional uterus the opportunity to have genetic offspring. The techniques involved are no different than those applied in other forms of ART, but the ethical, legal, and psychosocial issues involved are complex.

Gestational surrogacy involves transfer of embryos to the uterus of a woman willing to carry a pregnancy on behalf of an infertile couple. **Surrogacy is an option for couples wherein the female partner has no uterus (congenital, hysterectomy), an irreparably damaged uterus (congenital malformation, severe intrauterine adhesions), or a medical condition for which pregnancy may pose a life-threatening risk. Surrogacy is also an option for male same-sex couples who choose parenthood through assisted reproduction.** The host carrier may be a relative, a friend, or someone with no attachment to the couple who may or may not be compensated for her service. Regardless what the circumstances are, candidates for surrogacy should have previously given birth and undergo thorough psychological evaluation. The legal status of gestational surrogacy varies widely among different states, and even where it has recognition, a formal legal contract is required to formalize agreements between the infertile couple and the surrogate.

# GAMETE AND ZYGOTE INTRAFALLOPIAN TRANSFER

---

Gamete intrafallopian transfer and ZIFT are alternatives to IVF in which oocytes and sperm (GIFT) or zygotes (ZIFT) are transferred to the fallopian tubes via laparoscopy instead of into the uterus. Once commonly performed because they offered significantly higher success rates than IVF to women with normal tubal anatomy, both procedures are now extremely rare.

Combined data from the United States and Canada indicate that as of 1995, the delivery rates per retrieval for GIFT (27.0%) and ZIFT cycles (27.9%) were still higher than for IVF (22.5%).<sup>856</sup> Over subsequent years, IVF success rates steadily improved and surpassed those achieved with GIFT and ZIFT. Accordingly, the procedures now have few indications that can justify the greater costs and risks associated with surgical transfers. In 2015, the U.S. national ART registry reported that ZIFT and GIFT accounted for less than 1% of all ART procedures.<sup>5</sup>

In the GIFT procedure, stimulation and oocyte retrieval proceed as in a conventional IVF cycle. Very soon thereafter, laparoscopy is performed, and oocytes and sperm are drawn into a specially designed catheter (separated by air) and deposited into the fallopian tubes at a level approximately 4 cm proximal to the fimbria. The techniques involved in ZIFT are the same as for GIFT, except that conventional IVF is first performed in the laboratory and zygotes are transferred on the following day. Today, GIFT and ZIFT are reserved entirely for women in whom a uterine transfer cannot be accomplished for technical reasons. Whereas fertilization is documented in ZIFT, in GIFT, it is not. With GIFT, fertilization occurs in vivo rather than in vitro. For that reason, GIFT may be the only option for couples with personal, moral, ethical, or religious objections to conventional IVF. Predictably, the risk of ectopic pregnancy is higher for GIFT and ZIFT than for conventional IVF; the risk of multiple pregnancies is comparable.

# REFERENCES

1. **Step toe PC, Edwards RG**, Reimplantation of a human embryo with subsequent tubal pregnancy, *Lancet* 1:880, 1976.
2. **Step toe PC, Edwards RG**, Birth after the reimplantation of a human embryo, *Lancet* 2:366, 1978.
3. **Sunderam S, Kissin DM, Crawford SB, Folger SG, Boulet SL, Warner L, Barfield WD**, Assisted reproductive technology surveillance—United States, 2015, *MMWR Surveill Summ* 67:1, 2018.
4. **Pinter B, da Silva MO, Bloemenkamp K, Fronteira I, Karro H**, Assisted Reproductive Technologies in European Union: Findings of the Reproductive Health Report, 2018. [https://webgate.ec.europa.eu/chafea\\_pdb/assets/files/pdb/2007110/2007110\\_d12-01\\_en\\_ps.pdf](https://webgate.ec.europa.eu/chafea_pdb/assets/files/pdb/2007110/2007110_d12-01_en_ps.pdf)
5. **Centers for Disease Control and Prevention, American Society for Reproductive Medicine, Society for Assisted Reproductive Technology**, 2015 Assisted Reproductive Technology National Summary Report, 2017.
6. **Diamond E**, Lysis of postoperative pelvic adhesions in infertility, *Fertil Steril* 31(3):287, 1979.
7. **Gomel V**, Salpingo-ovariolysis by laparoscopy in infertility, *Fertil Steril* 40(5): 607, 1983.
8. **Donnez J, Casanas-Roux F**, Prognostic factors of fimbrial microsurgery, *Fertil Steril* 46:200, 1986.
9. **Dubuisson JB, Bouquet de Joliniere J, Aubriot FX, Darai E, Foulot H, Mandelbrot L**, Terminal tuboplasties by laparoscopy: 65 consecutive cases, *Fertil Steril* 54:401, 1990.
10. **Canis M, Mage G, Pouly JL, Manhes H, Wattiez A, Bruhat MA**, Laparoscopic distal tuboplasty: report of 87 cases and a 4-year experience, *Fertil Steril* 56:616, 1991.
11. **Dlugi AM, Reddy S, Saleh WA, Mersol-Barg MS, Jacobsen G**, Pregnancy rates after operative endoscopic treatment of total (neosalpingostomy), *Fertil Steril* 62:913, 1994.
12. **Taylor RC, Berkowitz J, McComb PF**, Role of laparoscopic salpingostomy in the treatment of hydrosalpinx, *Fertil Steril* 75:594, 2001.
13. **Beyler SA, James KP, Fritz MA, Meyer WR**, Hydrosalpingeal fluid inhibits in-vitro embryonic development in a murine model, *Hum Reprod* 12:2724, 1997.
14. **Meyer WR, Castelbaum AJ, Somkuti S, Sagoskin AW, Doyle M, Harris JE, Lessey BA**, Hydrosalpinges adversely affect markers of endometrial receptivity, *Hum Reprod* 12:1393, 1997.
15. **Cohen MA, Lindheim SR, Sauer MV**, Hydrosalpinges adversely affect implantation in donor oocyte cycles, *Hum Reprod* 14:1087, 1999.
16. **Strandell A, Lindhard A**, Why does hydrosalpinx reduce fertility? The importance of hydrosalpinx fluid, *Hum Reprod* 17:1141, 2002.
17. **Daftary GS, Taylor HS**, Hydrosalpinx fluid diminishes endometrial cell HOXA10 expression, *Fertil Steril* 78(3):577, 2002.
18. **Daftary GS, Kayisli U, Seli E, Bukulmez O, Arici A, Taylor HS**, Salpingectomy increases peri-implantation endometrial HOXA10 expression in women with hydrosalpinx, *Fertil Steril* 87(2):367, 2007.
19. **Johnson N, van Voorst S, Sowter MC, Strandell A, Mol BW**, Surgical treatment for tubal disease in women due to undergo in vitro, *Cochrane Database Syst Rev* (1):CD002125, 2010.
20. **Aboulghar MA, Mansour RT, Serour GI**, Spontaneous intrauterine pregnancy following salpingectomy for a unilateral hydrosalpinx, *Hum Reprod* 17:1099, 2002.
21. **Choe J, Check JH**, Salpingectomy for unilateral hydrosalpinx may improve in vivo fecundity, *Gynecol Obstet Invest* 48:285, 1999.
22. **Al-Jaroudi D, Herba MJ, Tulandi T**, Reproductive performance after selective tubal catheterization, *J Minim Invasive Gynecol* 12:150, 2005.
23. **Flood JT, Grow DR**, Transcervical tubal cannulation: a review, *Obstet Gynecol Surv* 48:768, 1993.
24. **Confino E, Tur-Kaspa I, DeCherney A, Corfman R, Coulam C, Robinson E, Haas G, Katz E, Vermesh M, Gleicher N**, Transcervical balloon tuboplasty. A multicenter study, *JAMA* 264:2079, 1990.
25. **Woolcott R, Fisher S, Thomas J, Kable W**, A randomized, prospective, controlled study of laparoscopic dye studies and selective salpingography as diagnostic tests of fallopian tube patency, *Fertil Steril* 72:879, 1999.

26. **Valle RF**, Tubal cannulation, *Obstet Gynecol Clin North Am* 22:519, 1995.
27. **Thurmond AS**, Selective salpingography and fallopian tube recanalization, *Am J Roentgenol* 156:33, 1991.
28. **Sankpal RS, Confino E, Matzel A, Cohen LS**, Investigation of the uterine cavity and fallopian tubes using three-dimensional saline sonohysterosalpingography, *Int J Gynaecol Obstet* 73:125, 2001.
29. **Papaioannou S, Afnan M, Girling AJ, Coomarasamy A, Ola B, Olufowobi O, McHugo JM, Hammadieh N, Sharif K**, Long-term fertility prognosis following selective salpingography and tubal catheterization in women with proximal tubal blockage, *Hum Reprod* 17:2325, 2002.
30. **Papaioannou S, Afnan M, Girling AJ, Coomarasamy A, Ola B, Olufowobi O, McHugo JM, Hammadieh N, Sharif K**, The effect on pregnancy rates of tubal perfusion pressure reductions achieved by guide-wire tubal catheterization, *Hum Reprod* 17:2174, 2002.
31. **Patton PE, Williams TJ, Coulam CB**, Microsurgical reconstruction of the proximal oviduct, *Fertil Steril* 47:35, 1987.
32. **Patton PE, Williams TJ, Coulam CB**, Results of microsurgical reconstruction in patients with combined proximal and distal tubal occlusion: double obstruction, *Fertil Steril* 48:670, 1987.
33. **Marana R, Quagliarello J**, Proximal tubal occlusion: microsurgery versus IVF—a review, *Int J Fertil* 33:338, 1988.
34. **Honore GM, Holden AE, Schenken RS**, Pathophysiology and management of proximal tubal blockage, *Fertil Steril* 71:785, 1999.
35. **Stephen EH, Chandra A**, Use of infertility services in the United States: 1995, *Fam Plann Perspect* 32:132, 2000.
36. **Borrero SB, Reeves MF, Schwarz EB, Bost JE, Creinin MD, Ibrahim SA**, Race, insurance status, and desire for tubal sterilization reversal, *Fertil Steril* 90:272, 2008.
37. **Schmidt JE, Hillis SD, Marchbanks PA, Jeng G, Peterson HB**, Requesting information about and obtaining reversal after tubal sterilization: findings from the U.S. Collaborative Review of Sterilization, *Fertil Steril* 74:892, 2000.
38. **Chi IC, Jones DB**, Incidence, risk factors, and prevention of poststerilization regret in women: an updated international review from an epidemiological perspective, *Obstet Gynecol Surv* 49:722, 1994.
39. **Neuhaus W, Bolte A**, Prognostic factors for preoperative consultation of women desiring sterilization: findings of a retrospective analysis, *J Psychosom Obstet Gynaecol* 16:45, 1995.
40. **Hardy E, Bahamondes L, Osis MJ, Costa RG, Faundes A**, Risk factors for tubal sterilization regret, detectable before surgery, *Contraception* 54:159, 1996.
41. **Curtis KM, Mohllajee AP, Peterson HB**, Regret following female sterilization at a young age: a systematic review, *Contraception* 73:205, 2006.
42. **Henderson SR**, The reversibility of female sterilization with the use of microsurgery: a report on 102 patients with more than one year of follow-up, *Am J Obstet Gynecol* 149:57, 1984.
43. **Rock JA, Chang YS, Limpaphayom K, Koetswang S, Moeloek FA, Guzick DS, Burkman RT, King TM**, Microsurgical tubal anastomosis: a controlled trial in four Asian centers, *Microsurgery* 5:95, 1984.
44. **Boeckx W, Gordts S, Buysse K, Brosens I**, Reversibility after female sterilization, *Br J Obstet Gynaecol* 93:839, 1986.
45. **te Velde ER, Boer ME, Looman CW, Habbema JD**, Factors influencing success or failure after reversal of sterilization: a multivariate approach, *Fertil Steril* 54:270, 1990.
46. **Winston RM**, Tubal surgery or in vitro fertilization (IVF)? *J Assist Reprod Genet* 9:309, 1992.
47. **Dubuisson JB, Chapron C, Nos C, Morice P, Aubriot FX, Garnier P**, Sterilization reversal: fertility results, *Hum Reprod* 10:1145, 1995.
48. **Rouzi AA, Mackinnon M, McComb PF**, Predictors of success of reversal of sterilization, *Fertil Steril* 64:29, 1995.
49. **Glock JL, Kim AH, Hulka JF, Hunt RB, Trad FS, Brumsted JR**, Reproductive outcome after tubal reversal in women 40 years of age or older, *Fertil Steril* 65:863, 1996.
50. **Schenken RS, Asch RH, Williams RF, Hodgen GD**, Etiology of infertility in monkeys with endometriosis: luteinized unruptured follicles, luteal phase defects, pelvic adhesions, and spontaneous abortions, *Fertil Steril* 41:

122, 1984.

51. **Toya M, Saito H, Ohta N, Saito T, Kaneko T, Hiroi M**, Moderate and severe endometriosis is associated with alterations in the cell cycle of granulosa cells in patients undergoing in vitro fertilization and embryo transfer, *Fertil Steril* 73:344, 2000.
52. **Oral E, Arici A, Olive DL, Huszar G**, Peritoneal fluid from women with moderate or severe endometriosis inhibits sperm motility: the role of seminal fluid components, *Fertil Steril* 66:787, 1996.
53. **Lyons RA, Djahanbakhch O, Saridogan E, Naftalin AA, Mahmood T, Weekes A, Chenoy R**, Peritoneal fluid, endometriosis, and ciliary beat frequency in the human fallopian tube, *Lancet* 360:1221, 2002.
54. **Lessey BA, Castelbaum AJ, Sawin SW, Buck CA, Schinnar R, Bilker W, Strom BL**, Aberrant integrin expression in the endometrium of women with endometriosis, *J Clin Endocrinol Metab* 79:643, 1994.
55. **Illera MJ, Juan L, Stewart CL, Cullinan E, Ruman J, Lessey BA**, Effect of peritoneal fluid from women with endometriosis on implantation in the mouse model, *Fertil Steril* 74:41, 2000.
56. **Macer ML, Taylor HS**, Endometriosis and infertility: a review of the pathogenesis and treatment of endometriosis-associated infertility, *Obstet Gynecol Clin North Am* 39(4):535, 2012.
57. **Bromer JG, Aldad TS, Taylor HS**, Defining the proliferative phase endometrial defect, *Fertil Steril* 91(3):698, 2009.
58. **Taylor HS, Bagot C, Kardana A, Olive D, Arici A**, HOX gene expression is altered in the endometrium of women with endometriosis, *Hum Reprod* 14(5):1328, 1999.
59. **Vercellini P, Vigano P, Frattaruolo MP, Borghi A, Somigliana E**, Bowel surgery as a fertility-enhancing procedure in patients with colorectal endometriosis: methodological, pathogenic and ethical issues, *Hum Reprod* 33:1205, 2018.
60. **Centini G, Afors K, Murtada R, Argay IM, Lazzeri L, Akladios CY, Zupi E, Petraglia F, Wattiez A**, Impact of laparoscopic surgical management of deep endometriosis on pregnancy rate, *J Minim Invasive Gynecol* 23:113, 2016.
61. **Adamson GD, Pasta DJ**, Surgical treatment of endometriosis-associated infertility: meta-analysis compared with survival analysis, *Am J Obstet Gynecol* 171:1488; discussion 1504–1505, 1994.
62. **Olive DL, Lee KL**, Analysis of sequential treatment protocols for endometriosis-associated infertility, *Am J Obstet Gynecol* 154:613, 1986.
63. **Ata B, Turkgeldi E, Seyhan A, Urman B**, Effect of hemostatic method on ovarian reserve following laparoscopic endometrioma excision; comparison of suture, hemostatic sealant, and bipolar desiccation. A systematic review and meta-analysis, *J Minim Invasive Gynecol* 22:363, 2015.
64. **Muzii L, Bellati F, Palaia I, Plotti F, Mancini N, Zullo MA, Angioli R, Panici PB**, Laparoscopic stripping of endometriomas: a randomized trial on different surgical techniques. Part I: clinical results, *Hum Reprod* 20:1981, 2005.
65. **Reich H, Abrao MS**, Post-surgical ovarian failure after laparoscopic excision of bilateral endometriomas: is this rare problem preventable? *Am J Obstet Gynecol* 195:339, 2006.
66. **Adamson GD, Pasta DJ**, Endometriosis fertility index: the new, validated endometriosis staging system, *Fertil Steril* 94:1609, 2010.
67. **Tomassetti C, Geysenbergh B, Meuleman C, Timmerman D, Fieuws S, D'Hooghe T**, External validation of the endometriosis fertility index (EFI) staging system for predicting non-ART pregnancy after endometriosis surgery, *Hum Reprod* 28:1280, 2013.
68. **Hobo R, Nakagawa K, Usui C, Sugiyama R, Ino N, Motoyama H, Kuribayashi Y, Inoue M, Sugiyama R**, The endometriosis fertility index is useful for predicting the ability to conceive without assisted reproductive technology treatment after laparoscopic surgery, regardless of endometriosis, *Gynecol Obstet Invest* 83:493, 2018.
69. **Maheux-Lacroix S, Nesbitt-Hawes E, Deans R, Won H, Budden A, Adamson D, Abbott JA**, Endometriosis fertility index predicts live births following surgical resection of moderate and severe endometriosis, *Hum Reprod* 32:2243, 2017.
70. **Zhang X, Liu D, Huang W, Wang Q, Feng X, Tan J**, Prediction of Endometriosis Fertility Index in patients with endometriosis-associated infertility after laparoscopic treatment, *Reprod Biomed Online* 37:53, 2018.

71. **Hamdan M, Dunselman G, Li TC, Cheong Y**, The impact of endometrioma on IVF/ICSI outcomes: a systematic review and meta-analysis, *Hum Reprod Update* 21:809, 2015.
72. **Seyhan A, Urman B, Turkogldi E, Ata B**, Do endometriomas grow during ovarian stimulation for assisted reproduction? A three-dimensional volume analysis before and after ovarian stimulation, *Reprod Biomed Online* 36:239, 2018.
73. **Benaglia L, Busnelli A, Biancardi R, Vegetti W, Reschini M, Vercellini P, Somigliana E**, Oocyte retrieval difficulties in women with ovarian endometriomas, *Reprod Biomed Online* 37:77, 2018.
74. **Padilla SL**, Ovarian abscess following puncture of an endometrioma during ultrasound-guided oocyte retrieval, *Hum Reprod* 8:1282, 1993.
75. **Younis JS, Ezra Y, Laufer N, Ohel G**, Late manifestation of pelvic abscess following oocyte retrieval, for in vitro fertilization, in patients with severe endometriosis and ovarian endometriomata, *J Assist Reprod Genet* 14:343, 1997.
76. **Moini A, Riazi K, Amid V, Ashrafi M, Tehraninejad E, Madani T, Owj M**, Endometriosis may contribute to oocyte retrieval-induced pelvic inflammatory disease: report of eight cases, *J Assist Reprod Genet* 22:307, 2005.
77. **Seyhan A, Ata B, Son WY, Dahan MH, Tan SL**, Comparison of complication rates and pain scores after transvaginal ultrasound-guided oocyte pickup procedures for in vitro maturation and in vitro fertilization cycles, *Fertil Steril* 101:705, 2014.
78. **Benaglia L, Somigliana E, Iemello R, Colpi E, Nicolosi AE, Ragni G**, Endometrioma and oocyte retrieval-induced pelvic abscess: a clinical concern or an exceptional complication? *Fertil Steril* 89:1263, 2008.
79. **Sallam HN, Garcia-Velasco JA, Dias S, Arici A**, Long-term pituitary down-regulation before in vitro fertilization (IVF) for women with endometriosis, *Cochrane Database Syst Rev* (1):CD004635, 2006.
80. **Drakopoulos P, Rosetti J, Pluchino N, Blockeel C, Santos-Ribeiro S, de Brucker M, Drakakis P, Camus M, Tournaye H, Polyzos NP**, Does the type of GnRH analogue used, affect live birth rates in women with endometriosis undergoing IVF/ICSI treatment, according to the rAFS stage? *Gynecol Endocrinol* 34:884, 2018.
81. **Rodriguez-Purata J, Coroleu B, Tur R, Carrasco B, Rodriguez I, Barri PN**, Endometriosis and IVF: are agonists really better? Analysis of 1180 cycles with the propensity score matching, *Gynecol Endocrinol* 29:859, 2013.
82. **Thonneau P, Marchand S, Tallec A, Ferial ML, Ducot B, Lansac J, Lopes P, Tabaste JM, Spira A**, Incidence and main causes of infertility in a resident population (1,850,000) of three French regions (1988-1989), *Hum Reprod* 6:811, 1991.
83. **Schlegel PN, Girardi SK**, Clinical review 87: in vitro fertilization for male factor infertility, *J Clin Endocrinol Metab* 82:709, 1997.
84. **Cooper TG, Noonan E, von Eckardstein S, Auger J, Baker HW, Behre HM, Haugen TB, Kruger T, Wang C, Mbizvo MT, Vogelsohn KM**, World Health Organization reference values for human semen characteristics, *Hum Reprod Update* 16:231, 2010.
85. **Guzick DS, Overstreet JW, Factor-Litvak P, Brazil CK, Nakajima ST, Coutifaris C, Carson SA, Cisneros P, Steinkampf MP, Hill JA, Xu D, Vogel DL; National Cooperative Reproductive Medicine Network**, Sperm morphology, motility, and concentration in fertile and infertile men, *N Engl J Med* 345:1388, 2001.
86. **van der Westerlaken LA, Naaktgeboren N, Helmerhorst FM**, Evaluation of pregnancy rates after intrauterine insemination according to indication, age, and sperm parameters, *J Assist Reprod Genet* 15:359, 1998.
87. **Miller DC, Hollenbeck BK, Smith GD, Randolph JF, Christman GM, Smith YR, Lebovic DI, Ohl DA**, Processed total motile sperm count correlates with pregnancy outcome after intrauterine insemination, *Urology* 60:497, 2002.
88. **Van Voorhis BJ, Barnett M, Sparks AE, Syrop CH, Rosenthal G, Dawson J**, Effect of the total motile sperm count on the efficacy and cost-effectiveness of intrauterine insemination and in vitro fertilization, *Fertil Steril* 75: 661, 2001.



89. **Campana A, Sakkas D, Stalberg A, Bianchi PG, Comte I, Pache T, Walker D**, Intrauterine insemination: evaluation of the results according to the woman's age, sperm quality, total sperm count per insemination and life table analysis, *Hum Reprod* 11:732, 1996.
90. **Nulsen JC, Walsh S, Dumez S, Metzger DA**, A randomized and longitudinal study of human menopausal gonadotropin with intrauterine insemination in the treatment of infertility, *Obstet Gynecol* 82:780, 1993.
91. **Erdem M, Erdem A, Mutlu MF, Ozisik S, Yildiz S, Guler I, Karakaya C**, The impact of sperm morphology on the outcome of intrauterine insemination cycles with gonadotropins in unexplained and male subfertility, *Eur J Obstet Gynecol Reprod Biol* 197:120, 2016.
92. **Ombelet W, Dhont N, Thijsen A, Bosmans E, Kruger T**, Semen quality and prediction of IUI success in male subfertility: a systematic review, *Reprod Biomed Online* 28:300, 2014.
93. **Deveneau NE, Sinno O, Krause M, Eastwood D, Sandlow JI, Robb P, Granlund A, Strawn EY Jr**, Impact of sperm morphology on the likelihood of pregnancy after intrauterine insemination, *Fertil Steril* 102:1584.e2, 2014.
94. **Kashanian JA, Brannigan RE**, Sperm morphology and reproductive outcomes: a perplexing relationship, *Fertil Steril* 102:1561, 2014.
95. **Lee J, Hwang S, Lee J, Yoo J, Jang D, Hwang K, Kim M**, Effect of insemination timing on pregnancy outcome in association with female age, sperm motility, sperm morphology and sperm concentration in intrauterine insemination, *J Obstet Gynaecol Res* 44:1100, 2018.
96. **Lemmens L, Kos S, Beijer C, Brinkman JW, van der Horst FA, van den Hoven L, Kieslinger DC, van Trooyen-van Vrouwerff NJ, Wolhuis A, Hendriks JC, Wetzels AM; Semen Section of the Dutch Foundation for Quality Assessment in Medical Laboratories**, Predictive value of sperm morphology and progressively motile sperm count for pregnancy outcomes in intrauterine insemination, *Fertil Steril* 105:1462, 2016.
97. **Kruger TF, Acosta AA, Simmons KF, Swanson RJ, Matta JF, Oehninger S**, Predictive value of abnormal sperm morphology in in vitro fertilization, *Fertil Steril* 49:112, 1988.
98. **Van Uem JF, Acosta AA, Swanson RJ, Mayer J, Ackerman S, Burkman LJ, Veeck L, McDowell JS, Bernardus RE, Jones HW Jr**, Male factor evaluation in in vitro fertilization: norfolk experience, *Fertil Steril* 44:375, 1985.
99. **Hernandez M, Molina R, Olmedo J, Olmedo SB, Coetzee K, Estofan D**, Prognostic value of the strict criteria: an Argentinian experience, *Arch Androl* 37:87, 1996.
100. **Vawda AI, Gunby J, Younglai EV**, Semen parameters as predictors of in-vitro fertilization: the importance of strict criteria sperm morphology, *Hum Reprod* 11:1445, 1996.
101. **Ombelet W, Fourie FL, Vandeput H, Bosmans E, Cox A, Janssen M, Kruger T**, Teratozoospermia and in-vitro fertilization: a randomized prospective study, *Hum Reprod* 9:1479, 1994.
102. **Menkveld R, Kruger TF**, Advantages of strict (Tygerberg) criteria for evaluation of sperm morphology, *Int J Androl* 18(Suppl 2):36, 1995.
103. **Hall J, Fishel S, Green S, Fleming S, Hunter A, Stoddart N, Dowell K, Thornton S**, Intracytoplasmic sperm injection versus high insemination concentration in-vitro fertilization in cases of very severe teratozoospermia, *Hum Reprod* 10:493, 1995.
104. **Mansour RT, Aboulghar MA, Serour GI, Amin YM, Ramzi AM**, The effect of sperm parameters on the outcome of intracytoplasmic sperm injection, *Fertil Steril* 64:982, 1995.
105. **Robinson JN, Lockwood GM, Dokras A, Egan DM, Nicholson SC, Ross C, Barlow DH**, Does isolated teratozoospermia affect performance in in-vitro fertilization and embryo transfer? *Hum Reprod* 9:870, 1994.
106. **Keegan BR, Barton S, Sanchez X, Berkeley AS, Krey LC, Grifo J**, Isolated teratozoospermia does not affect in vitro fertilization outcome and is not an indication for intracytoplasmic sperm injection, *Fertil Steril* 88:1583, 2007.
107. **Dodson WC, Whitesides DB, Hughes CLJ, Easley HA III, Haney AF**, Superovulation with intrauterine insemination in the treatment of infertility: a possible alternative to gamete intrafallopian transfer and in vitro fertilization, *Fertil Steril* 48:441, 1987.
108. **Crosignani PG, Collins J, Cooke ID, Diczfalusy E, Rubin B**, Unexplained infertility, *Hum Reprod* 8:977,

1993.

109. **Crosignani PG, Collins J, Cooke ID, Diczfalusy E, Rubin B**, Recommendations of the ESHRE workshop on “Unexplained Infertility”. Anacapri, August 28-9, 1992, Hum Reprod 8:977, 1993.
110. **Guzick DS, Sullivan MW, Adamson GD, Cedars MI, Falk RJ, Peterson EP, Steinkampf MP**, Efficacy of treatment for unexplained infertility, Fertil Steril 70:207, 1998.
111. **Reindollar RH, Regan MM, Neumann PJ, Levine BS, Thornton KL, Alper MM, Goldman MB**, A randomized clinical trial to evaluate optimal treatment for unexplained infertility: the fast track and standard treatment (FASTT) trial, Fertil Steril 94:888, 2010.
112. **Custers IM, Steures P, Hompes P, Flierman P, van Kasteren Y, van Dop PA, van der Veen F, Mol BW**, Intrauterine insemination: how many cycles should we perform? Hum Reprod 23:885, 2008.
113. **Dovey S, Sneeringer RM, Penzias AS**, Clomiphene citrate and intrauterine insemination: analysis of more than 4100 cycles, Fertil Steril 90:2281, 2008.
114. **Guzick DS, Carson SA, Coutifaris C, Overstreet JW, Factor-Litvak P, Steinkampf MP, Hill JA, Mastroianni L, Buster JE, Nakajima ST, Vogel DL, Canfield RE**, Efficacy of superovulation and intrauterine insemination in the treatment of infertility. National Cooperative Reproductive Medicine Network, N Engl J Med 340:177, 1999.
115. **Steures P, van der Steeg JW, Hompes PG, Habbema JD, Eijkemans MJ, Broekmans FJ, Verhoeve HR, Bossuyt PM, van der Veen F, Mol BW, Collaborative Effort on the Clinical Evaluation in Reproductive Medicine**, Intrauterine insemination with controlled ovarian hyperstimulation versus expectant management for couples with unexplained subfertility and an intermediate prognosis: a randomised clinical trial, Lancet 368:216, 2006.
116. **Hughes EG, Beecroft ML, Wilkie V, Burville L, Claman P, Tummon I, Greenblatt E, Fluker M, Thorpe K**, A multicentre randomized controlled trial of expectant management versus IVF in women with Fallopian tube patency, Hum Reprod 19:1105, 2004.
117. **Gurgan T, Urman B, Yarali H, Kisanisci HA**, The results of in vitro fertilization-embryo transfer in couples with unexplained infertility failing to conceive with superovulation and intrauterine insemination, Fertil Steril 64:93, 1995.
118. **Ruiz A, Remohi J, Minguez Y, Guanes PP, Simon C, Pellicer A**, The role of in vitro fertilization and intracytoplasmic sperm injection in couples with unexplained infertility after failed intrauterine insemination, Fertil Steril 68:171, 1997.
119. **Takeuchi S, Minoura H, Shibahara T, Shen X, Futamura N, Toyoda N**, In vitro fertilization and intracytoplasmic sperm injection for couples with unexplained infertility after failed direct intraperitoneal insemination, J Assist Reprod Genet 17:515, 2000.
120. **Martin JS, Nisker JA, Parker JI, Kaplan B, Tummon IS, Yuzpe AA**, The pregnancy rates of cohorts of idiopathic infertility couples gives insights into the underlying mechanism of infertility, Fertil Steril 64:98, 1995.
121. **Boulet SL, Mehta A, Kissin DM, Warner L, Kawwass JF, Jamieson DJ**, Trends in use of and reproductive outcomes associated with intracytoplasmic sperm injection, JAMA 313:255, 2015.
122. **Kushnir VA, Barad DH, Gleicher N**, Intracytoplasmic sperm injection and reproductive outcomes, JAMA 313:1672, 2015.
123. **Li Z, Wang AY, Bowman M, Hammarberg K, Farquhar C, Johnson L, Safi N, Sullivan EA**, ICSI does not increase the cumulative live birth rate in non-male factor infertility, Hum Reprod 33:1322, 2018.
124. **Navot D, Laufer N, Kopolovic J, Rabinowitz R, Birkenfeld A, Lewin A, Granat M, Margalioth EJ, Schenker JG**, Artificially induced endometrial cycles and establishment of pregnancies in the absence of ovaries, N Engl J Med 314:806, 1986.
125. **Oktay K, Rodriguez-Wallberg K, Schover L**, Preservation of fertility in patients with cancer, N Engl J Med 360:2681; author reply 2682, 2009.
126. **Grifo JA, Noyes N**, Delivery rate using cryopreserved oocytes is comparable to conventional in vitro fertilization using fresh oocytes: potential fertility preservation for female cancer patients, Fertil Steril 93:391, 2010.
127. **Practice Committees of American Society for Reproductive Medicine; Society for Assisted**

- Reproductive Technology**, Mature oocyte cryopreservation: a guideline, *Fertil Steril* 99:37, 2013.
128. **Cobo A, Kuwayama M, Perez S, Ruiz A, Pellicer A, Remohi J**, Comparison of concomitant outcome achieved with fresh and cryopreserved donor oocytes vitrified by the Cryotop method, *Fertil Steril* 89:1657, 2008.
  129. **Brinsden PR**, Gestational surrogacy, *Hum Reprod Update* 9:483, 2003.
  130. **Utian WH, Sheean L, Goldfarb JM, Kiwi R**, Successful pregnancy after in vitro fertilization and embryo transfer from an infertile woman to a surrogate, *N Engl J Med* 313:1351, 1985.
  131. **Practice Committee of Society for Assisted Reproductive Technology; Practice Committee of American Society for Reproductive Medicine**, Preimplantation genetic testing: a Practice Committee opinion, *Fertil Steril* 90:S136, 2008.
  132. **Practice Committees of the American Society for Reproductive Medicine and the Society for Assisted Reproductive Technology**, The use of preimplantation genetic testing for aneuploidy (PGT-A): a committee opinion, *Fertil Steril* 109:429, 2018.
  133. **Malizia BA, Hacker MR, Penzias AS**, Cumulative live-birth rates after in vitro fertilization, *N Engl J Med* 360:236, 2009.
  134. **Ata B, Kaplan B, Danzer H, Glassner M, Opsahl M, Tan SL, Munne S**, Array CGH analysis shows that aneuploidy is not related to the number of embryos generated, *Reprod Biomed Online* 24:614, 2012.
  135. **Sauer MV, Paulson RJ, Lobo RA**, Reversing the natural decline in human fertility. An extended clinical trial of oocyte donation to women of advanced reproductive age, *JAMA* 268:1275, 1992.
  136. **Hull MG, Fleming CF, Hughes AO, McDermott A**, The age-related decline in female fecundity: a quantitative controlled study of implanting capacity and survival of individual embryos after in vitro fertilization, *Fertil Steril* 65:783, 1996.
  137. **Ziebe S, Loft A, Petersen JH, Andersen AG, Lindenberg S, Petersen K, Andersen AN**, Embryo quality and developmental potential is compromised by age, *Acta Obstet Gynecol Scand* 80:169, 2001.
  138. **van Rooij IA, Bancsi LF, Broekmans FJ, Looman CW, Habbema JD, te Velde ER**, Women older than 40 years of age and those with elevated follicle-stimulating hormone levels differ in poor response rate and embryo quality in in vitro fertilization, *Fertil Steril* 79:482, 2003.
  139. **Hull MG**, Effectiveness of infertility treatments: choice and comparative analysis, *Int J Gynaecol Obstet* 47:99, 1994.
  140. **Munne S, Held KR, Magli CM, Ata B, Wells D, Fragouli E, Baukloh V, Fischer R, Gianaroli L**, Intra-age, intercenter, and intercycle differences in chromosome abnormalities in oocytes, *Fertil Steril* 97:935, 2012.
  141. **Pellestor F, Andreo B, Arnal F, Humeau C, Demaille J**, Maternal aging and chromosomal abnormalities: new data drawn from in vitro unfertilized human oocytes, *Hum Genet* 112:195, 2003.
  142. **Nasmyth K**, Disseminating the genome: joining, resolving, and separating sister chromatids during mitosis and meiosis, *Annu Rev Genet* 35:673, 2001.
  143. **Battaglia DE, Goodwin P, Klein NA, Soules MR**, Influence of maternal age on meiotic spindle assembly in oocytes from naturally cycling women, *Hum Reprod* 11:2217, 1996.
  144. **Spandorfer SD, Bendikson K, Dragisic K, Schattman G, Davis OK, Rosenwaks Z**, Outcome of in vitro fertilization in women 45 years and older who use autologous oocytes, *Fertil Steril* 87:74, 2007.
  145. **Sunkara SK, Rittenberg V, Raine-Fenning N, Bhattacharya S, Zamora J, Coomarasamy A**, Association between the number of eggs and live birth in IVF treatment: an analysis of 400 135 treatment cycles, *Hum Reprod* 26:1768, 2011.
  146. **Richardson SJ, Senikas V, Nelson JF**, Follicular depletion during the menopausal transition: evidence for accelerated loss and ultimate exhaustion, *J Clin Endocrinol Metab* 65:1231, 1987.
  147. **Faddy MJ, Gosden RG**, A model conforming the decline in follicle numbers to the age of menopause in women, *Hum Reprod* 11:1484, 1996.
  148. **Gougeon A, Ecochard R, Thalabard JC**, Age-related changes of the population of human ovarian follicles: increase in the disappearance rate of non-growing and early-growing follicles in aging women, *Biol Reprod* 50:653, 1994.
  149. **Nilsson E, Rogers N, Skinner MK**, Actions of anti-Mullerian hormone on the ovarian transcriptome to

inhibit primordial to primary follicle transition, *Reproduction* 134:209, 2007.

150. **Adhikari D, Liu K**, Molecular mechanisms underlying the activation of mammalian primordial follicles, *Endocr Rev* 30:438, 2009.
151. **Da Silva-Buttkus P, Marcelli G, Franks S, Stark J, Hardy K**, Inferring biological mechanisms from spatial analysis: prediction of a local inhibitor in the ovary, *Proc Natl Acad Sci U S A* 106:456, 2009.
152. **Coxworth JE, Hawkes K**, Ovarian follicle loss in humans and mice: lessons from statistical model comparison, *Hum Reprod* 25:1796, 2010.
153. **Klein NA, Battaglia DE, Fujimoto VY, Davis GS, Bremner WJ, Soules MR**, Reproductive aging: accelerated ovarian follicular development associated with a monotropic follicle-stimulating hormone rise in normal older women, *J Clin Endocrinol Metab* 81:1038, 1996.
154. **Klein NA, Battaglia DE, Miller PB, Branigan EF, Giudice LC, Soules MR**, Ovarian follicular development and the follicular fluid hormones and growth factors in normal women of advanced reproductive age, *J Clin Endocrinol Metab* 81:1946, 1996.
155. **Hofmann GE, Danforth DR, Seifer DB**, Inhibin-B: the physiologic basis of the clomiphene citrate challenge test for ovarian reserve screening, *Fertil Steril* 69:474, 1998.
156. **Welt CK, McNicholl DJ, Taylor AE, Hall JE**, Female reproductive aging is marked by decreased secretion of dimeric inhibin, *J Clin Endocrinol Metab* 84:105, 1999.
157. **Seifer DB, Scott RT Jr, Bergh PA, Abrogast LK, Friedman CI, Mack CK, Danforth DR**, Women with declining ovarian reserve may demonstrate a decrease in day 3 serum inhibin B before a rise in day 3 follicle-stimulating hormone, *Fertil Steril* 72:63, 1999.
158. **Klein NA, Houmard BS, Hansen KR, Woodruff TK, Sluss PM, Bremner WJ, Soules MR**, Age-related analysis of inhibin A, inhibin B, and activin a relative to the intercycle monotropic follicle-stimulating hormone rise in normal ovulatory women, *J Clin Endocrinol Metab* 89:2977, 2004.
159. **Hale GE, Zhao X, Hughes CL, Burger HG, Robertson DM, Fraser IS**, Endocrine features of menstrual cycles in middle and late reproductive age and the menopausal transition classified according to the Staging of Reproductive Aging Workshop (STRAW) staging system, *J Clin Endocrinol Metab* 92:3060, 2007.
160. **Knauff EA, Eijkemans MJ, Lambalk CB, ten Kate-Booij MJ, Hoek A, Beerendonk CC, Laven JS, Goverde AJ, Broekmans FJ, Themmen AP, de Jong FH, Fauser BC; Dutch Premature Ovarian Failure Consortium**, Anti-Mullerian hormone, inhibin B, and antral follicle count in young women with ovarian failure, *J Clin Endocrinol Metab* 94:786, 2009.
161. **Burger HG, Hale GE, Dennerstein L, Robertson DM**, Cycle and hormone changes during perimenopause: the key role of ovarian function, *Menopause* 15:603, 2008.
162. **Klein NA, Harper AJ, Houmard BS, Sluss PM, Soules MR**, Is the short follicular phase in older women secondary to advanced or accelerated dominant follicle development? *J Clin Endocrinol Metab* 87:5746, 2002.
163. **van Zonneveld P, Scheffer GJ, Broekmans FJ, Blankenstein MA, de Jong FH, Looman CW, Habbema JD, te Velde ER**, Do cycle disturbances explain the age-related decline of female fertility? Cycle characteristics of women aged over 40 years compared with a reference population of young women, *Hum Reprod* 18:495, 2003.
164. **de Koning CH, McDonnell J, Themmen AP, de Jong FH, Homburg R, Lambalk CB**, The endocrine and follicular growth dynamics throughout the menstrual cycle in women with consistently or variably elevated early follicular phase FSH compared with controls, *Hum Reprod* 23:1416, 2008.
165. **Muasher SJ, Oehninger S, Simonetti S, Matta J, Ellis LM, Liu HC, Jones GS, Rosenwaks Z**, The value of basal and/or stimulated serum gonadotropin levels in prediction of stimulation response and in vitro fertilization outcome, *Fertil Steril* 50:298, 1988.
166. **Scott RT, Toner JP, Muasher SJ, Oehninger S, Robinson S, Rosenwaks Z**, Follicle-stimulating hormone levels on cycle day 3 are predictive of in vitro fertilization outcome, *Fertil Steril* 51:651, 1989.
167. **Toner JP, Philput CB, Jones GS, Muasher SJ**, Basal follicle-stimulating hormone level is a better predictor of in vitro fertilization performance than age, *Fertil Steril* 55:784, 1991.
168. **Pearlstone AC, Fournet N, Gambone JC, Pang SC, Buyalos RP**, Ovulation induction in women age 40 and older: the importance of basal follicle-stimulating hormone level and chronological age, *Fertil Steril* 58:674,

1992.

169. **Scott RT Jr, Hofmann GE**, Prognostic assessment of ovarian reserve, *Fertil Steril* 63:1, 1995.
170. **Broekmans FJ, Kwee J, Hendriks DJ, Mol BW, Lambalk CB**, A systematic review of tests predicting ovarian reserve and IVF outcome, *Hum Reprod Update* 12:685, 2006.
171. **Barroso G, Oehninger S, Monzo A, Kolm P, Gibbons WE, Muasher SJ**, High FSH:LH ratio and low LH levels in basal cycle day 3: impact on follicular development and IVF outcome, *J Assist Reprod Genet* 18:499, 2001.
172. **Hazout A, Bouchard P, Seifer DB, Aussage P, Junca AM, Cohen-Bacrie P**, Serum antimullerian hormone/mullerian-inhibiting substance appears to be a more discriminatory marker of assisted reproductive technology outcome than follicle-stimulating hormone, inhibin B, or estradiol, *Fertil Steril* 82:1323, 2004.
173. **Eldar-Geva T, Ben-Chetrit A, Spitz IM, Rabinowitz R, Markowitz E, Mimoni T, Gal M, Zylber-Haran E, Margalioth EJ**, Dynamic assays of inhibin B, anti-Mullerian hormone and estradiol following FSH stimulation and ovarian ultrasonography as predictors of IVF outcome, *Hum Reprod* 20:3178, 2005.
174. **McIlveen M, Skull JD, Ledger WL**, Evaluation of the utility of multiple endocrine and ultrasound measures of ovarian reserve in the prediction of cycle cancellation in a high-risk IVF population, *Hum Reprod* 22:778, 2007.
175. **Phophong P, Ranieri DM, Khadum I, Meo F, Serhal P**, Basal 17beta-estradiol did not correlate with ovarian response and in vitro fertilization treatment outcome, *Fertil Steril* 74:1133, 2000.
176. **Evers JL, Slaats P, Land JA, Dumoulin JC, Dunselman GA**, Elevated levels of basal estradiol-17beta predict poor response in patients with normal basal levels of follicle-stimulating hormone undergoing in vitro fertilization, *Fertil Steril* 69:1010, 1998.
177. **Smotrich DB, Widra EA, Gindoff PR, Levy MJ, Hall JL, Stillman RJ**, Prognostic value of day 3 estradiol on in vitro fertilization outcome, *Fertil Steril* 64:1136, 1995.
178. **Licciardi FL, Liu HC, Rosenwaks Z**, Day 3 estradiol serum concentrations as prognosticators of ovarian stimulation response and pregnancy outcome in patients undergoing in vitro fertilization, *Fertil Steril* 64:991, 1995.
179. **Buyalos RP, Daneshmand S, Brzechffa PR**, Basal estradiol and follicle-stimulating hormone predict fecundity in women of advanced reproductive age undergoing ovulation induction therapy, *Fertil Steril* 68:272, 1997.
180. **Sowers MR, Eyvazzadeh AD, McConnell D, Yosef M, Jannausch ML, Zhang D, Harlow S, Randolph JF Jr**, Anti-mullerian hormone and inhibin B in the definition of ovarian aging and the menopause transition, *J Clin Endocrinol Metab* 93:3478, 2008.
181. **van Rooij IA, Tonkelaar I, Broekmans FJ, Looman CW, Scheffer GJ, de Jong FH, Themmen AP, te Velde ER**, Anti-mullerian hormone is a promising predictor for the occurrence of the menopausal transition, *Menopause* 11:601, 2004.
182. **van Rooij IA, Broekmans FJ, Scheffer GJ, Looman CW, Habbema JD, de Jong FH, Fauser BJ, Themmen AP, te Velde ER**, Serum antimullerian hormone levels best reflect the reproductive decline with age in normal women with proven fertility: a longitudinal study, *Fertil Steril* 83:979, 2005.
183. **de Vet A, Laven JS, de Jong FH, Themmen AP, Fauser BC**, Antimullerian hormone serum levels: a putative marker for ovarian aging, *Fertil Steril* 77:357, 2002.
184. **Muttukrishna S, McGarrigle H, Wakim R, Khadum I, Ranieri DM, Serhal P**, Antral follicle count, anti-mullerian hormone and inhibin B: predictors of ovarian response in assisted reproductive technology? *BJOG* 112:1384, 2005.
185. **Muttukrishna S, Suharjono H, McGarrigle H, Sathanandan M**, Inhibin B and anti-Mullerian hormone: markers of ovarian response in IVF/ICSI patients? *BJOG* 111:1248, 2004.
186. **van Rooij IA, Broekmans FJ, te Velde ER, Fauser BC, Bancsi LF, de Jong FH, Themmen AP**, Serum anti-Mullerian hormone levels: a novel measure of ovarian reserve, *Hum Reprod* 17:3065, 2002.
187. **Silberstein T, MacLaughlin DT, Shai I, Trimarchi JR, Lambert-Messerlian G, Seifer DB, Keefe DL, Blazar AS**, Mullerian inhibiting substance levels at the time of HCG administration in IVF cycles predict both ovarian reserve and embryo morphology, *Hum Reprod* 21:159, 2006.

188. **Ebner T, Sommergruber M, Moser M, Shebl O, Schreier-Lechner E, Tews G**, Basal level of anti-Mullerian hormone is associated with oocyte quality in stimulated cycles, *Hum Reprod* 21:2022, 2006.
189. **Kedem A, Haas J, Geva LL, Yerushalmi G, Gilboa Y, Kanety H, Hanochi M, Maman E, Hourvitz A**, Ongoing pregnancy rates in women with low and extremely low AMH levels. A multivariate analysis of 769 cycles, *PLoS One* 8:e81629, 2013.
190. **Lin WQ, Yao LN, Zhang DX, Zhang W, Yang XJ, Yu R**, The predictive value of anti-Mullerian hormone on embryo quality, blastocyst development, and pregnancy rate following in vitro fertilization-embryo transfer (IVF-ET), *J Assist Reprod Genet* 30:649, 2013.
191. **Mutlu MF, Erdem M, Erdem A, Yildiz S, Mutlu I, Arisoy O, Oktem M**, Antral follicle count determines poor ovarian response better than anti-Mullerian hormone but age is the only predictor for live birth in in vitro fertilization cycles, *J Assist Reprod Genet* 30:657, 2013.
192. **Reichman DE, Goldschlag D, Rosenwaks Z**, Value of antimullerian hormone as a prognostic indicator of in vitro fertilization outcome, *Fertil Steril* 101:1012.e1, 2014.
193. **Broer SL, van Disseldorp J, Broeze KA, Dolleman M, Opmeer BC, Bossuyt P, Eijkemans MJ, Mol BW, Broekmans FJ; IMPORT study group**, Added value of ovarian reserve testing on patient characteristics in the prediction of ovarian response and ongoing pregnancy: an individual patient data approach, *Hum Reprod Update* 19:26, 2013.
194. **Iliodromiti S, Kelsey TW, Wu O, Anderson RA, Nelson SM**, The predictive accuracy of anti-Mullerian hormone for live birth after assisted conception: a systematic review and meta-analysis of the literature, *Hum Reprod Update* 20:560, 2014.
195. **Tal R, Tal O, Seifer BJ, Seifer DB**, Antimullerian hormone as predictor of implantation and clinical pregnancy after assisted conception: a systematic review and meta-analysis, *Fertil Steril* 103:119.e3, 2015.
196. **Broer SL, Dolleman M, van Disseldorp J, Broeze KA, Opmeer BC, Bossuyt PM, Eijkemans MJ, Mol BW, Broekmans FJ, Group I-ES**, Prediction of an excessive response in in vitro fertilization from patient characteristics and ovarian reserve tests and comparison in subgroups: an individual patient data meta-analysis, *Fertil Steril* 100:420.e7, 2013.
197. **Seifer DB, MacLaughlin DT, Christian BP, Feng B, Sheldon RM**, Early follicular serum mullerian-inhibiting substance levels are associated with ovarian response during assisted reproductive technology cycles, *Fertil Steril* 77:468, 2002.
198. **Morin SJ, Patounakis G, Juneau CR, Neal SA, Scott RT Jr, Seli E**, Diminished ovarian reserve and poor response to stimulation in patients <38 years old: a quantitative but not qualitative reduction in performance, *Hum Reprod*, 2018 Jul 11. doi: 10.1093/humrep/dey238.
199. **Ficicioglu C, Kutlu T, Baglam E, Bakacak Z**, Early follicular antimullerian hormone as an indicator of ovarian reserve, *Fertil Steril* 85:592, 2006.
200. **Gnoth C, Schuring AN, Friol K, Tigges J, Mallmann P, Godehardt E**, Relevance of anti-Mullerian hormone measurement in a routine IVF program, *Hum Reprod* 23:1359, 2008.
201. **Penarrubia J, Fabregues F, Manau D, Creus M, Casals G, Casamitjana R, Carmona F, Vanrell JA, Balasch J**, Basal and stimulation day 5 anti-Mullerian hormone serum concentrations as predictors of ovarian response and pregnancy in assisted reproductive technology cycles stimulated with gonadotropin-releasing hormone agonist—gonadotropin treatment, *Hum Reprod* 20:915, 2005.
202. **Elgindy EA, El-Haieg DO, El-Sebaey A**, Anti-Mullerian hormone: correlation of early follicular, ovulatory and midluteal levels with ovarian response and cycle outcome in intracytoplasmic sperm injection patients, *Fertil Steril* 89:1670, 2008.
203. **Pache TD, Wladimiroff JW, de Jong FH, Hop WC, Fauser BC**, Growth patterns of nondominant ovarian follicles during the normal menstrual cycle, *Fertil Steril* 54:638, 1990.
204. **Meldrum DR, Chetkowski RJ, Steingold KA, Randle D**, Transvaginal ultrasound scanning of ovarian follicles, *Fertil Steril* 42:803, 1984.
205. **Bancsi LF, Broekmans FJ, Looman CW, Habbema JD, te Velde ER**, Impact of repeated antral follicle counts on the prediction of poor ovarian response in women undergoing in vitro fertilization, *Fertil Steril* 81:35, 2004.

206. **Hansen KR, Morris JL, Thyer AC, Soules MR**, Reproductive aging and variability in the ovarian antral follicle count: application in the clinical setting, *Fertil Steril* 80:577, 2003.
207. **Scheffer GJ, Broekmans FJ, Bancsi LF, Habbema JD, Looman CW, Te Velde ER**, Quantitative transvaginal two- and three-dimensional sonography of the ovaries: reproducibility of antral follicle counts, *Ultrasound Obstet Gynecol* 20:270, 2002.
208. **Bancsi LF, Broekmans FJ, Eijkemans MJ, de Jong FH, Habbema JD, te Velde ER**, Predictors of poor ovarian response in in vitro fertilization: a prospective study comparing basal markers of ovarian reserve, *Fertil Steril* 77:328, 2002.
209. **Frattarelli JL, Lauria-Costab DF, Miller BT, Bergh PA, Scott RT**, Basal antral follicle number and mean ovarian diameter predict cycle cancellation and ovarian responsiveness in assisted reproductive technology cycles, *Fertil Steril* 74:512, 2000.
210. **Frattarelli JL, Levi AJ, Miller BT, Segars JH**, A prospective assessment of the predictive value of basal antral follicles in in vitro fertilization cycles, *Fertil Steril* 80:350, 2003.
211. **Hendriks DJ, Mol BW, Bancsi LF, Te Velde ER, Broekmans FJ**, Antral follicle count in the prediction of poor ovarian response and pregnancy after in vitro fertilization: a meta-analysis and comparison with basal follicle-stimulating hormone level, *Fertil Steril* 83:291, 2005.
212. **Chang MY, Chiang CH, Hsieh TT, Soong YK, Hsu KH**, Use of the antral follicle count to predict the outcome of assisted reproductive technologies, *Fertil Steril* 69:505, 1998.
213. **Ng EH, Tang OS, Ho PC**, The significance of the number of antral follicles prior to stimulation in predicting ovarian responses in an IVF programme, *Hum Reprod* 15:1937, 2000.
214. **Kupesic S, Kurjak A, Bjelos D, Vujisic S**, Three-dimensional ultrasonographic ovarian measurements and in vitro fertilization outcome are related to age, *Fertil Steril* 79:190, 2003.
215. **La Marca A, Sighinolfi G, Radi D, Argento C, Baraldi E, Artenisio AC, Stabile G, Volpe A**, Anti-Mullerian hormone (AMH) as a predictive marker in assisted reproductive technology (ART), *Hum Reprod Update* 16:113, 2010.
216. **Lukaszuk K, Kunicki M, Liss J, Lukaszuk M, Jakiel G**, Use of ovarian reserve parameters for predicting live births in women undergoing in vitro fertilization, *Eur J Obstet Gynecol Reprod Biol* 168:173, 2013.
217. **Polyzos NP, Nelson SM, Stoop D, Nwoye M, Humaidan P, Anckaert E, Devroey P, Tournaye H**, Does the time interval between antimullerian hormone serum sampling and initiation of ovarian stimulation affect its predictive ability in in vitro fertilization-intracytoplasmic sperm injection cycles with a gonadotropin-releasing hormone antagonist? A retrospective single-center study, *Fertil Steril* 100:438, 2013.
218. **Scott RT Jr, Elkind-Hirsch KE, Styne-Gross A, Miller KA, Frattarelli JL**, The predictive value for in vitro fertility delivery rates is greatly impacted by the method used to select the threshold between normal and elevated basal follicle-stimulating hormone, *Fertil Steril* 89:868, 2008.
219. **van Rooij IA, de Jong E, Broekmans FJ, Looman CW, Habbema JD, te Velde ER**, High follicle-stimulating hormone levels should not necessarily lead to the exclusion of subfertile patients from treatment, *Fertil Steril* 81:1478, 2004.
220. **Lashen H, Ledger W, Lopez-Bernal A, Barlow D**, Poor responders to ovulation induction: is proceeding to in-vitro fertilization worthwhile? *Hum Reprod* 14:964, 1999.
221. **Zhen XM, Qiao J, Li R, Wang LN, Liu P**, The clinical analysis of poor ovarian response in in-vitro-fertilization embryo-transfer among Chinese couples, *J Assist Reprod Genet* 25:17, 2008.
222. **Broekmans FJ, Soules MR, Fauser BC**, Ovarian aging: mechanisms and clinical consequences, *Endocr Rev* 30:465, 2009.
223. **Strandell A, Lindhard A, Eckerlund I**, Cost-effectiveness analysis of salpingectomy prior to IVF, based on a randomized controlled trial, *Hum Reprod* 20:3284, 2005.
224. **Kotlyar A, Gingold J, Shue S, Falcone T**, The effect of salpingectomy on ovarian function, *J Minim Invasive Gynecol* 24:563, 2017.
225. **Mohamed AA, Yosef AH, James C, Al-Hussaini TK, Bedaiwy MA, Amer S**, Ovarian reserve after salpingectomy: a systematic review and meta-analysis, *Acta Obstet Gynecol Scand* 96:795, 2017.
226. **Zhang Y, Sun Y, Guo Y, Li TC, Duan H**, Salpingectomy and proximal tubal occlusion for hydrosalpinx prior

to in vitro fertilization: a meta-analysis of randomized controlled trials, *Obstet Gynecol Surv* 70:33, 2015.

227. **Van Voorhis BJ, Sparks AE, Syrop CH, Stovall DW**, Ultrasound-guided aspiration of hydrosalpinges is associated with improved pregnancy and implantation rates after in-vitro fertilization cycles, *Hum Reprod* 13:736, 1998.
228. **Tsiami A, Chaimani A, Mavridis D, Siskou M, Assimakopoulos E, Sotiriadis A**, Surgical treatment for hydrosalpinx prior to in-vitro fertilization embryo transfer: a network meta-analysis, *Ultrasound Obstet Gynecol* 48:434, 2016.
229. **Bloechle M, Schreiner T, Lisse K**, Recurrence of hydrosalpinges after transvaginal aspiration of tubal fluid in an IVF cycle with development of a serometra, *Hum Reprod* 12:703, 1997.
230. **Xu B, Zhang Q, Zhao J, Wang Y, Xu D, Li Y**, Pregnancy outcome of in vitro fertilization after Essure and laparoscopic management of hydrosalpinx: a systematic review and meta-analysis, *Fertil Steril* 108:84.e5, 2017.
231. **Barbosa MW, Sotiriadis A, Papatheodorou SI, Mijatovic V, Nastri CO, Martins WP**, High miscarriage rate in women treated with Essure(R) for hydrosalpinx before embryo transfer: a systematic review and meta-analysis, *Ultrasound Obstet Gynecol* 48:556, 2016.
232. **Rackow BW, Taylor HS**, Submucosal uterine leiomyomas have a global effect on molecular determinants of endometrial receptivity, *Fertil Steril* 93(6):2027, 2010.
233. **Sinclair DC, Mastroyannis A, Taylor HS**, Leiomyoma simultaneously impair endometrial BMP-2-mediated decidualization and anticoagulant expression through secretion of TGF- $\beta$ 3, *J Clin Endocrinol Metab* 96(2):412, 2011.
234. **Doherty LF, Taylor HS**, Leiomyoma-derived transforming growth factor- $\beta$  impairs bone morphogenetic protein-2-mediated endometrial receptivity, *Fertil Steril* 103(3):845, 2015.
235. **Olive DL, Pritts EA**, Fibroids and reproduction, *Semin Reprod Med* 28:218, 2010.
236. **Ezzati M, Norian JM, Segars JH**, Management of uterine fibroids in the patient pursuing assisted reproductive technologies, *Womens Health (Lond)* 5:413, 2009.
237. **Benecke C, Kruger TF, Siebert TI, Van der Merwe JP, Steyn DW**, Effect of fibroids on fertility in patients undergoing assisted reproduction. A structured literature review, *Gynecol Obstet Invest* 59:225, 2005.
238. **Somigliana E, Vercellini P, Daguati R, Pasin R, De Giorgi O, Crosignani PG**, Fibroids and female reproduction: a critical analysis of the evidence, *Hum Reprod Update* 13:465, 2007.
239. **Klatsky PC, Tran ND, Caughey AB, Fujimoto VY**, Fibroids and reproductive outcomes: a systematic literature review from conception to delivery, *Am J Obstet Gynecol* 198:357, 2008.
240. **Pritts EA, Parker WH, Olive DL**, Fibroids and infertility: an updated systematic review of the evidence, *Fertil Steril* 91:1215, 2009.
241. **Hartmann KE, Velez Edwards DR, Savitz DA, Jonsson-Funk ML, Wu P, Sundermann AC, Baird DD**, Prospective cohort study of uterine fibroids and miscarriage risk, *Am J Epidemiol* 186:1140, 2017.
242. **Eldar-Geva T, Meagher S, Healy DL, MacLachlan V, Breheny S, Wood C**, Effect of intramural, subserosal, and submucosal uterine fibroids on the outcome, *Fertil Steril* 70:687, 1998.
243. **Stovall DW, Parrish SB, Van Voorhis BJ, Hahn SJ, Sparks AE, Syrop CH**, Uterine leiomyomas reduce the efficacy of assisted reproduction cycles: results, *Hum Reprod* 13:192, 1998.
244. **Healy DL**, Impact of uterine fibroids on ART outcome, *Environ Health Perspect* 108(Suppl 5):845, 2000.
245. **Hart R, Khalaf Y, Yeong CT, Seed P, Taylor A, Braude P**, A prospective controlled study of the effect of intramural uterine fibroids on the outcome of assisted conception, *Hum Reprod* 16:2411, 2001.
246. **Khalaf Y, Ross C, El-Toukhy T, Hart R, Seed P, Braude P**, The effect of small intramural uterine fibroids on the cumulative outcome of assisted conception, *Hum Reprod* 21:2640, 2006.
247. **Farhi J, Ashkenazi J, Feldberg D, Dicker D, Orvieto R, Ben Rafael Z**, Effect of uterine leiomyomata on the results of in-vitro fertilization treatment, *Hum Reprod* 10:2576, 1995.
248. **Dietterich C, Check JH, Choe JK, Nazari A, Fox F**, The presence of small uterine fibroids not distorting the endometrial cavity does not adversely affect conception outcome following embryo transfer in older recipients, *Clin Exp Obstet Gynecol* 27:168, 2000.
249. **Jun SH, Ginsburg ES, Racowsky C, Wise LA, Hornstein MD**, Uterine leiomyomas and their effect on in vitro fertilization outcome: a retrospective study, *J Assist Reprod Genet* 18:139, 2001.



250. **Surrey ES, Lietz AK, Schoolcraft WB**, Impact of intramural leiomyomata in patients with a normal endometrial cavity on in vitro fertilization-embryo transfer cycle outcome, *Fertil Steril* 75:405, 2001.
251. **Check JH, Choe JK, Lee G, Dietterich C**, The effect on IVF outcome of small intramural fibroids not compressing the uterine cavity as determined by a prospective matched control study, *Hum Reprod* 17:1244, 2002.
252. **Oliveira FG, Abdelmassih VG, Diamond MP, Dozortsev D, Melo NR, Abdelmassih R**, Impact of subserosal and intramural uterine fibroids that do not distort the endometrial cavity on the outcome of in vitro fertilization-intracytoplasmic sperm injection, *Fertil Steril* 81:582, 2004.
253. **Sunkara SK, Khairy M, El-Toukhy T, Khalaf Y, Coomarasamy A**, The effect of intramural fibroids without uterine cavity involvement on the outcome of IVF treatment: a systematic review and meta-analysis, *Hum Reprod* 25:418, 2010.
254. **Taylor HS**, Fibroids: when should they be removed to improve in vitro fertilization success? *Fertil Steril* 109(5):784, 2018.
255. **Hornstein MD**, Lifestyle and IVF outcomes, *Reprod Sci* 23:1626, 2016.
256. **Firns S, Cruzat VF, Keane KN, Joesbury KA, Lee AH, Newsholme P, Yovich JL**, The effect of cigarette smoking, alcohol consumption and fruit and vegetable consumption on IVF outcomes: a review and presentation of original data, *Reprod Biol Endocrinol* 13:134, 2015.
257. **Waylen AL, Metwally M, Jones GL, Wilkinson AJ, Ledger WL**, Effects of cigarette smoking upon clinical outcomes of assisted reproduction: a meta-analysis, *Hum Reprod Update* 15:31, 2009.
258. **Schachter-Safrai N, Karavani G, Levitas E, Friger M, Zeadna A, Lunenfeld E, Har-Vardi I**, Does cryopreservation of sperm affect fertilization in nonobstructive azoospermia or cryptozoospermia? *Fertil Steril* 107:1148, 2017.
259. **Morshedi M, Oehninger S, Veeck LL, Ertunc H, Bocca S, Acosta AA**, Cryopreserved/thawed semen for in vitro fertilization: results from fertile donors and infertile patients, *Fertil Steril* 54:1093, 1990.
260. **Yavetz H, Lessing JB, Niv Y, Amit A, Barak Y, Yovel I, David MP, Peyser MR, Yogevev L, Homonnai Z**, et al., The efficiency of cryopreserved semen versus fresh semen for in vitro fertilization/embryo transfer, *J In Vitro Fert Embryo Transf* 8:145, 1991.
261. **Karayalcin R, Ozcan S, Moraloglu O, Ozyer S, Mollamahmutoglu L, Batioglu S**, Results of 2500 office-based diagnostic hysteroscopies before IVF, *Reprod Biomed Online* 20:689, 2010.
262. **El-Mazny A, Abou-Salem N, El-Sherbiny W, Saber W**, Outpatient hysteroscopy: a routine investigation before assisted reproductive techniques? *Fertil Steril* 95:272, 2011.
263. **Fatemi HM, Kasius JC, Timmermans A, van Disseldorp J, Fauser BC, Devroey P, Broekmans FJ**, Prevalence of unsuspected uterine cavity abnormalities diagnosed by office hysteroscopy prior to in vitro fertilization, *Hum Reprod* 25:1959, 2010.
264. **Smit JG, Kasius JC, Eijkemans MJC, Koks CAM, van Golde R, Nap AW, Scheffer GJ, Manger PAP, Hoek A, Schoot BC, van Heusden AM, Kuchenbecker WKH, Perquin DAM, Fleischer K, Kaaijk EM, Sluijmer A, Friederich J, Dykgraaf RHM, van Hooff M, Louwe LA, Kwee J, de Koning CH, Janssen I, Mol F, Mol BWJ, Broekmans FJM, Torrance HL**, Hysteroscopy before in-vitro fertilisation (inSIGHT): a multicentre, randomised controlled trial, *Lancet* 387:2622, 2016.
265. **El-Toukhy T, Campo R, Khalaf Y, Tabanelli C, Gianaroli L, Gordts SS, Gordts S, Mestdagh G, Mardesic T, Voboril J, Marchino GL, Benedetto C, Al-Shawaf T, Sabatini L, Seed PT, Gergolet M, Grimbizis G, Harb H, Coomarasamy A**, Hysteroscopy in recurrent in-vitro fertilisation failure (TROPHY): a multicentre, randomised controlled trial, *Lancet* 387:2614, 2016.
266. **Becker E Jr, Lev-Toaff AS, Kaufman EP, Halpern EJ, Edelweiss MI, Kurtz AB**, The added value of transvaginal sonohysterography over transvaginal sonography alone in women with known or suspected leiomyoma, *J Ultrasound Med* 21:237, 2002.
267. **Leone FP, Lanzani C, Ferrazzi E**, Use of strict sonohysterographic methods for preoperative assessment of submucous myomas, *Fertil Steril* 79:998, 2003.
268. **Sylvestre C, Child TJ, Tulandi T, Tan SL**, A prospective study to evaluate the efficacy of two- and three-dimensional sonohysterography in women with intrauterine lesions, *Fertil Steril* 79:1222, 2003.

269. **Henne MB, Milki AA**, Uterine position at real embryo transfer compared with mock embryo transfer, *Hum Reprod* 19:570, 2004.
270. **Miller KL, Frattarelli JL**, The pre-cycle blind mock embryo transfer is an inaccurate predictor of anticipated embryo transfer depth, *J Assist Reprod Genet* 24:77, 2007.
271. **Sallam HN**, Embryo transfer: factors involved in optimizing the success, *Curr Opin Obstet Gynecol* 17:289, 2005.
272. **Mansour RT, Aboulghar MA**, Optimizing the embryo transfer technique, *Hum Reprod* 17:1149, 2002.
273. **Aboulghar MA, Mansour RT, Serour GA, Amin YM, Sattar MA, Ramzy AM**, In vitro fertilization in a spontaneous cycle: a successful simple protocol, *J Obstet Gynaecol (Tokyo)* 1995) 21:337, 1995.
274. **Nargund G, Waterstone J, Bland J, Philips Z, Parsons J, Campbell S**, Cumulative conception and live birth rates in natural (unstimulated) IVF cycles, *Hum Reprod* 16:259, 2001.
275. **Pelinc M, Hoek A, Simons AH, Heineman MJ**, Efficacy of natural cycle IVF: a review of the literature, *Hum Reprod Update* 8:129, 2002.
276. **Castelo-Branco A, Frydman N, Kadoch J, Le Du A, Fernandez H, Fanchin R, Frydman R**, [The role of the semi natural cycle as option of treatment of patients with a poor prognosis for successful in vitro fertilization], *J Gynecol Obstet Biol Reprod (Paris)* 33:518, 2004.
277. **Kolibianakis E, Zikopoulos K, Camus M, Tournaye H, Van Steirteghem A, Devroey P**, Modified natural cycle for IVF does not offer a realistic chance of parenthood in poor responders with high day 3 FSH levels, as a last resort prior to oocyte donation, *Hum Reprod* 19:2545, 2004.
278. **Weghofer A, Margreiter M, Bassim S, Sevela U, Beilhack E, Feichtinger W**, Minimal stimulation using recombinant follicle-stimulating hormone and a gonadotropin-releasing hormone antagonist in women of advanced age, *Fertil Steril* 81:1002, 2004.
279. **Elizur SE, Aslan D, Shulman A, Weisz B, Bider D, Dor J**, Modified natural cycle using GnRH antagonist can be an optional treatment in poor responders undergoing IVF, *J Assist Reprod Genet* 22:75, 2005.
280. **Pelinc M, Vogel NE, Hoek A, Simons AH, Arts EG, Mochtar MH, Beemsterboer S, Hondelink MN, Heineman MJ**, Cumulative pregnancy rates after three cycles of minimal stimulation IVF and results according to subfertility diagnosis: a multicentre cohort study, *Hum Reprod* 21:2375, 2006.
281. **Verberg MF, Macklon NS, Nargund G, Frydman R, Devroey P, Broekmans FJ, Fauser BC**, Mild ovarian stimulation for IVF, *Hum Reprod Update* 15:13, 2009.
282. **Trounson AO, Leeton JF, Wood C, Webb J, Wood J**, Pregnancies in humans by fertilization in vitro and embryo transfer in the controlled ovulatory cycle, *Science* 212:681, 1981.
283. **Quigley MM, Schmidt CL, Beauchamp PJ, Pace-Owens S, Berkowitz AS, Wolf DP**, Enhanced follicular recruitment in an in vitro fertilization program: clomiphene alone versus a clomiphene/human menopausal gonadotropin combination, *Fertil Steril* 42:25, 1984.
284. **Macklon NS, Stouffer RL, Giudice LC, Fauser BC**, The science behind 25 years of ovarian stimulation for in vitro fertilization, *Endocr Rev* 27:170, 2006.
285. **Dickey RP, Taylor SN, Rye PH, Lu PY**, Future use of clomiphene in ovarian stimulation. A role for clomiphene in the 21st century? *Hum Reprod* 13:2361, 1998.
286. **Messinis IE, Milingos SD**, Future use of clomiphene in ovarian stimulation. Clomiphene in the 21st century, *Hum Reprod* 13:2362, 1998.
287. **Ingerslev HJ, Hojgaard A, Hindkjaer J, Kesmodel U**, A randomized study comparing IVF in the unstimulated cycle with IVF following clomiphene citrate, *Hum Reprod* 16:696, 2001.
288. **Branigan EF, Estes MA**, Minimal stimulation IVF using clomiphene citrate and oral contraceptive pill pretreatment for LH suppression, *Fertil Steril* 73:587, 2000.
289. **MacDougall MJ, Tan SL, Hall V, Balen A, Mason BA, Jacobs HS**, Comparison of natural with clomiphene citrate-stimulated cycles in in vitro fertilization: a prospective, randomized trial, *Fertil Steril* 61:1052, 1994.
290. **Diamond MP, Hill GA, Webster BW, Herbert CM, Rogers BJ, Osteen KG, Maxson WS, Vaughn WK, Wentz AC**, Comparison of human menopausal gonadotropin, clomiphene citrate, and combined human menopausal gonadotropin-clomiphene citrate stimulation protocols for in vitro fertilization, *Fertil Steril* 46:1108,

1986.

291. **Corfman RS, Milad MP, Bellavance TL, Ory SJ, Erickson LD, Ball GD**, A novel ovarian stimulation protocol for use with the assisted reproductive technologies, *Fertil Steril* 60:864, 1993.
292. **Dor J, Ben-Shlomo I, Levran D, Rudak E, Yunish M, Mashiach S**, The relative success of gonadotropin-releasing hormone analogue, clomiphene citrate, and gonadotropin in 1,099 cycles of in vitro fertilization, *Fertil Steril* 58:986, 1992.
293. **Weigert M, Krischker U, Pohl M, Poschalko G, Kindermann C, Feichtinger W**, Comparison of stimulation with clomiphene citrate in combination with recombinant follicle-stimulating hormone and recombinant luteinizing hormone to stimulation with a gonadotropin-releasing hormone agonist protocol: a prospective, randomized study, *Fertil Steril* 78:34, 2002.
294. **Dhont M, Onghena A, Coetsier T, De Sutter P**, Prospective randomized study of clomiphene citrate and gonadotrophins versus goserelin and gonadotrophins for follicular stimulation in assisted reproduction, *Hum Reprod* 10:791, 1995.
295. **Lin YH, Hwang JL, Seow KM, Huang LW, Hsieh BC, Tzeng CR**, Comparison of outcome of clomiphene citrate/human menopausal gonadotropin/cetrorelix protocol and buserelin long protocol—a randomized study, *Gynecol Endocrinol* 22:297, 2006.
296. **Fiedler K, Ludwig M**, Use of clomiphene citrate in in vitro fertilization (IVF) and IVF/intracytoplasmic sperm injection cycles, *Fertil Steril* 80:1521, 2003.
297. **Williams SC, Gibbons WE, Muasher SJ, Oehninger S**, Minimal ovarian hyperstimulation for in vitro fertilization using sequential clomiphene citrate and gonadotropin with or without the addition of a gonadotropin-releasing hormone antagonist, *Fertil Steril* 78:1068, 2002.
298. **Mansour R, Aboulghar M, Serour GI, Al-Inany HG, Fahmy I, Amin Y**, The use of clomiphene citrate/human menopausal gonadotrophins in conjunction with GnRH antagonist in an IVF/ICSI program is not a cost effective protocol, *Acta Obstet Gynecol Scand* 82:48, 2003.
299. **Kawachiya SST, Kato K, Takehara Y, Teramoto S, Kato O**, The effectiveness of clomiphene citrate in suppressing the LH surge in the minimal stimulation IVF protocol, *Fertil Steril* 86:S412, 2006.
300. **Kato K, Takehara Y, Segawa T, Kawachiya S, Okuno T, Kobayashi T, Bodri D, Kato O**, Minimal ovarian stimulation combined with elective single embryo transfer policy; age-specific results of a large, single-centre, Japanese cohort, *Reprod Biol Endocrinol* 27:35, 2012.
301. **Bodri D, Kawachiya S, De Brucker M, Tournaye H, Kondo M, Kato R, Matsumoto T**, Cumulative success rates following mild IVF in unselected infertile patients: a 3-year, single-centre cohort study, *Reprod Biomed Online* 28: 572, 2014.
302. **Zhang J, Chang L, Sone Y, Silber S**, Minimal ovarian stimulation (mini-IVF) for IVF utilizing vitrification and cryopreserved embryo transfer, *Reprod Biomed Online* 21:485, 2010.
303. **Meldrum D**, GnRH agonists as adjuncts for in vitro fertilization, *Obstet Gynecol Surv* 44:314, 1989.
304. **Edwards RG, Lobo R, Bouchard P**, Time to revolutionize ovarian stimulation, *Hum Reprod* 11:917, 1996.
305. **Janssens RM, Lambalk CB, Vermeiden JP, Schats R, Bernards JM, Rekers-Mombarg LT, Schoemaker J**, Dose-finding study of triptorelin acetate for prevention of a premature LH surge in IVF: a prospective, randomized, double-blind, placebo-controlled study, *Hum Reprod* 15:2333, 2000.
306. **Hughes EG, Fedorkow DM, Daya S, Sagle MA, Van de Koppel P, Collins JA**, The routine use of gonadotropin-releasing hormone agonists prior to in vitro fertilization and gamete intrafallopian transfer: a meta-analysis of randomized controlled trials, *Fertil Steril* 58:888, 1992.
307. **Daya S**, Gonadotropin releasing hormone agonist protocols for pituitary desensitization in in vitro fertilization and gamete intrafallopian transfer cycles, *Cochrane Database Syst Rev* (2):CD001299, 2000.
308. **Meldrum DR, Wisot A, Hamilton F, Gutlay AL, Huynh D, Kempton W**, Timing of initiation and dose schedule of leuprolide influence the time course of ovarian suppression, *Fertil Steril* 50:400, 1988.
309. **Urbancsek J, Witthaus E**, Midluteal buserelin is superior to early follicular phase buserelin in combined gonadotropin-releasing hormone analog and gonadotropin stimulation in in vitro fertilization, *Fertil Steril* 65:966, 1996.
310. **El-Nemr A, Bhide M, Khalifa Y, Al-Mizyen E, Gillott C, Lower AM, Al-Shawaf T, Grudzinskas JG**,

Clinical evaluation of three different gonadotrophin-releasing hormone analogues in an IVF programme: a prospective study, *Eur J Obstet Gynecol Reprod Biol* 103:140, 2002.

311. **Albuquerque LE, Saconato H, Maciel MC**, Depot versus daily administration of gonadotrophin releasing hormone agonist protocols for pituitary desensitization in assisted reproduction cycles, *Cochrane Database Syst Rev* (3):CD002808, 2002.
312. **Thatcher SS, Jones E, DeCherney AH**, Ovarian cysts decrease the success of controlled ovarian stimulation and in vitro fertilization, *Fertil Steril* 52:812, 1989.
313. **Keltz MD, Jones EE, Duleba AJ, Polcz T, Kennedy K, Olive DL**, Baseline cyst formation after luteal phase gonadotropin-releasing hormone agonist administration is linked to poor in vitro fertilization outcome, *Fertil Steril* 64:568, 1995.
314. **Segal S, Shifren JL, Isaacson KB, Leykin L, Chang Y, Pal L, Toth TL**, Effect of a baseline ovarian cyst on the outcome of in vitro fertilization-embryo transfer, *Fertil Steril* 71:274, 1999.
315. **Zeyneloglu HB, Isik AZ, Kara S, Senoz S, Ozcan U, Gokmen O**, Impact of baseline cysts at the time of administration of gonadotropin-releasing hormone analog for in vitro fertilization, *Int J Fertil Womens Med* 43:300, 1998.
316. **Penzias AS, Jones EE, Seifer DB, Grifo JA, Thatcher SS, DeCherney AH**, Baseline ovarian cysts do not affect clinical response to controlled ovarian hyperstimulation for in vitro fertilization, *Fertil Steril* 57:1017, 1992.
317. **Goldberg JM, Miller FA, Friedman CI, Dodds WG, Kim MH**, Effect of baseline ovarian cysts on in vitro fertilization and gamete intrafallopian transfer cycles, *Fertil Steril* 55:319, 1991.
318. **Hornstein MD, Barbieri RL, Ravnikar VA, McShane PM**, The effects of baseline ovarian cysts on the clinical response to controlled ovarian hyperstimulation in an in vitro fertilization program, *Fertil Steril* 52:437, 1989.
319. **Karande VC, Scott RT, Jones GS, Muasher SJ**, Non-functional ovarian cysts do not affect ipsilateral or contralateral ovarian performance during in-vitro fertilization, *Hum Reprod* 5:431, 1990.
320. **McDonnell R, Marjoribanks J, Hart RJ**, Ovarian cyst aspiration prior to in vitro fertilization treatment for subfertility, *Cochrane Database Syst Rev* (12):CD005999, 2014.
321. **Oudshoorn SC, van Tilborg TC, Eijkemans MJC, Oosterhuis GJE, Friederich J, van Hooff MHA, van Santbrink EJP, Brinkhuis EA, Smeenk JMJ, Kwee J, de Koning CH, Groen H, Lambalk CB, Mol BWJ, Broekmans FJM, Torrance HL; OPTIMIST study group**, Individualized versus standard FSH dosing in women starting IVF/ICSI: an RCT. Part 2: the predicted hyper responder, *Hum Reprod* 32:2506, 2017.
322. **van Tilborg TC, Oudshoorn SC, Eijkemans MJC, Mochtar MH, van Golde RJT, Hoek A, Kuchenbecker WKH, Fleischer K, de Bruin JP, Groen H, van Wely M, Lambalk CB, Laven JSE, Mol BWJ, Broekmans FJM, Torrance HL; OPTIMIST study group**, Individualized FSH dosing based on ovarian reserve testing in women starting IVF/ICSI: a multicentre trial and cost-effectiveness analysis, *Hum Reprod* 32:2485, 2017.
323. **van Tilborg TC, Torrance HL, Oudshoorn SC, Eijkemans MJC, Koks CAM, Verhoeve HR, Nap AW, Scheffer GJ, Manger AP, Schoot BC, Sluijmer AV, Verhoeff A, Groen H, Laven JSE, Mol BWJ, Broekmans FJM; OPTIMIST study group**, Individualized versus standard FSH dosing in women starting IVF/ICSI: an RCT. Part 1: the predicted poor responder, *Hum Reprod* 32:2496, 2017.
324. **van Tilborg TC, Torrance HL, Oudshoorn SC, Eijkemans MJC, Mol BW, Broekmans FJM; OPTIMIST study group**, The end for individualized dosing in IVF ovarian stimulation? Reply to letters-to-the-editor regarding the OPTIMIST papers, *Hum Reprod* 33:984, 2018.
325. **La Marca A, Blockeel C, Bosch E, Fanchin R, Fatemi HM, Fauser BC, Garcia-Velasco JA, Humaidan P, Tarlatzis BC, Nelson SM**, Individualized FSH dosing improves safety and reduces iatrogenic poor response while maintaining live-birth rates, *Hum Reprod* 33:982, 2018.
326. **Nelson SM, Anderson RA**, Derailing individualized ovarian stimulation, *Hum Reprod* 33:980, 2018.
327. **Sunkara SK, Polyzos NP, OPTIMIST trial**: optimistic evidence? *Hum Reprod* 33:983, 2018.
328. **Daya S**, Methodologic pitfalls in assessing the efficacy of recombinant follicle-stimulating hormone versus human menopausal gonadotropin in assisted reproduction, *Fertil Steril* 80:1100, 2003.

329. **van Wely M, Westergaard LG, Bossuyt PM, van der Veen F**, Human menopausal gonadotropin and recombinant follicle-stimulating hormone for controlled ovarian hyperstimulation in assisted reproductive cycles, *Fertil Steril* 80:1121, 2003.
330. **Filicori M, Cognigni GE, Pocognoli P, Ciampaglia W**, Choice of ovarian stimulation regimens in assisted reproduction: finding the thread in the gonadotropin maze, *Fertil Steril* 80:1114, 2003.
331. **Collins J**, A turbulent arena, *Fertil Steril* 80:1117, 2003.
332. **van Wely M, Kwan I, Burt AL, Thomas J, Vail A, Van der Veen F, Al-Inany HG**, Recombinant versus urinary gonadotrophin for ovarian stimulation in assisted reproductive technology cycles, *Cochrane Database Syst Rev* (2):CD005354, 2011.
333. **Mannaerts B, Shoham Z, Schoot D, Bouchard P, Harlin J, Fauser B, Jacobs H, Rombout F, Coelingh Bennink H**, Single-dose pharmacokinetics and pharmacodynamics of recombinant human follicle-stimulating hormone (Org 32489\*) in gonadotropin-deficient volunteers, *Fertil Steril* 59:108, 1993.
334. **Duijkers IJ, Klipping C, Boerrigter PJ, Machielsen CS, De Bie JJ, Voortman G**, Single dose pharmacokinetics and effects on follicular growth and serum hormones of a long-acting recombinant FSH preparation (FSH-CTP) in healthy pituitary-suppressed females, *Hum Reprod* 17:1987, 2002.
335. **Seyhan A, Ata B**, The role of corifollitropin alfa in controlled ovarian stimulation for IVF in combination with GnRH antagonist, *Int J Womens Health* 3:243, 2011.
336. **Pouwer AW, Farquhar C, Kremer JA**, Long-acting FSH versus daily FSH for women undergoing assisted reproduction, *Cochrane Database Syst Rev* (7): CD009577, 2015.
337. **Balash J, Vidal E, Penarrubia J, Casamitjana R, Carmona F, Creus M, Fabregues F, Vanrell JA**, Suppression of LH during ovarian stimulation: analysing threshold values and effects on ovarian response and the outcome of assisted reproduction in down-regulated women stimulated with recombinant FSH, *Hum Reprod* 16:1636, 2001.
338. **Chappel SC, Howles C**, Reevaluation of the roles of luteinizing hormone and follicle-stimulating hormone in the ovulatory process, *Hum Reprod* 6:1206, 1991.
339. **Laml T, Obruca A, Fischl F, Huber JC**, Recombinant luteinizing hormone in ovarian hyperstimulation after stimulation failure in normogonadotropic women, *Gynecol Endocrinol* 13:98, 1999.
340. **Filicori M, Cognigni GE, Taraborrelli S, Spettoli D, Ciampaglia W, de Fatis CT, Pocognoli P**, Luteinizing hormone activity supplementation enhances follicle-stimulating hormone efficacy and improves ovulation induction outcome, *J Clin Endocrinol Metab* 84:2659, 1999.
341. **Fleming R, Chung CC, Yates RW, Coutts JR**, Purified urinary follicle stimulating hormone induces different hormone profiles compared with menotrophins, dependent upon the route of administration and endogenous luteinizing hormone activity, *Hum Reprod* 11:1854, 1996.
342. **Fleming R, Rehka P, Deshpande N, Jamieson ME, Yates RW, Lyall H**, Suppression of LH during ovarian stimulation: effects differ in cycles stimulated with purified urinary FSH and recombinant FSH, *Hum Reprod* 15:1440, 2000.
343. **Westergaard LG, Erb K, Laursen S, Rasmussen PE, Rex S**, The effect of human menopausal gonadotrophin and highly purified, urine-derived follicle stimulating hormone on the outcome of in-vitro fertilization in down-regulated normogonadotropic women, *Hum Reprod* 11:1209, 1996.
344. **Westergaard LG, Erb K, Laursen SB, Rex S, Rasmussen PE**, Human menopausal gonadotropin versus recombinant follicle-stimulating hormone in normogonadotropic women down-regulated with a gonadotropin-releasing hormone agonist who were undergoing in vitro fertilization and intracytoplasmic sperm injection: a prospective randomized study, *Fertil Steril* 76:543, 2001.
345. **Gordon UD, Harrison RF, Fawzy M, Hennelly B, Gordon AC**, A randomized prospective assessor-blind evaluation of luteinizing hormone dosage and in vitro fertilization outcome, *Fertil Steril* 75:324, 2001.
346. **Sills ES, Levy DP, Moomjy M, McGee M, Rosenwaks Z**, A prospective, randomized comparison of ovulation induction using highly purified follicle-stimulating hormone alone and with recombinant human luteinizing hormone in in-vitro fertilization, *Hum Reprod* 14:2230, 1999.
347. A double-blind, randomized, dose-finding study to assess the efficacy of the gonadotrophin-releasing hormone antagonist ganirelix (Org 37462) to prevent premature luteinizing hormone surges in women undergoing ovarian

- stimulation with recombinant follicle stimulating hormone (Puregon). The ganirelix dose-finding study group, *Hum Reprod* 13:3023, 1998.
348. **Westergaard LG, Laursen SB, Andersen CY**, Increased risk of early pregnancy loss by profound suppression of luteinizing hormone during ovarian stimulation in normogonadotrophic women undergoing assisted reproduction, *Hum Reprod* 15:1003, 2000.
  349. **Esposito MA, Barnhart KT, Coutifaris C, Patrizio P**, Role of periovulatory luteinizing hormone concentrations during assisted reproductive technology cycles stimulated exclusively with recombinant follicle-stimulating hormone, *Fertil Steril* 75:519, 2001.
  350. **Lehert P, Kolibianakis EM, Venetis CA, Schertz J, Saunders H, Arriagada P, Copt S, Tarlatzis B**, Recombinant human follicle-stimulating hormone (r-hFSH) plus recombinant luteinizing hormone versus r-hFSH alone for ovarian stimulation during assisted reproductive technology: systematic review and meta-analysis, *Reprod Biol Endocrinol* 12:17, 2014.
  351. **Pandian Z, McTavish AR, Aucott L, Hamilton MP, Bhattacharya S**, Interventions for “poor responders” to controlled ovarian hyper stimulation (COH) in in-vitro fertilisation (IVF), *Cochrane Database Syst Rev* (1):CD004379, 2010.
  352. **Konig TE, van der Houwen LE, Overbeek A, Hendriks ML, Beutler-Beemsterboer SN, Kuchenbecker WK, Renckens CN, Bernardus RE, Schats R, Homburg R, Hompes PG, Lambalk CB**, Recombinant LH supplementation to a standard GnRH antagonist protocol in women of 35 years or older undergoing IVF/ICSI: a randomized controlled multicentre study, *Hum Reprod* 28:2804, 2013.
  353. **Vuong TN, Phung HT, Ho MT**, Recombinant follicle-stimulating hormone and recombinant luteinizing hormone versus recombinant follicle-stimulating hormone alone during GnRH antagonist ovarian stimulation in patients aged  $\geq 35$  years: a randomized controlled trial, *Hum Reprod* 30:1188, 2015.
  354. **Bosch E, Labarta E, Crespo J, Simon C, Remohi J, Pellicer A**, Impact of luteinizing hormone administration on gonadotropin-releasing hormone antagonist cycles: an age-adjusted analysis, *Fertil Steril* 95:1031, 2011.
  355. **Humaidan P, Chin W, Rogoff D, D’Hooghe T, Longobardi S, Hubbard J, Schertz J; ESPART Study Investigators**, Efficacy and safety of follitropin alfa/lutropin alfa in ART: a randomized controlled trial in poor ovarian responders, *Hum Reprod* 32:544, 2017.
  356. **Ata B, Seli E**, Strategies for controlled ovarian stimulation in the setting of ovarian aging, *Semin Reprod Med* 33:436, 2015.
  357. **Coomarasamy A, Afnan M, Cheema D, van der Veen F, Bossuyt PM, van Wely M**, Urinary hMG versus recombinant FSH for controlled ovarian hyperstimulation following an agonist long down-regulation protocol in IVF or ICSI treatment: a systematic review and meta-analysis, *Hum Reprod* 23:310, 2008.
  358. **Ata B, Tulandi T**, Ultrasound automated volume calculation in reproduction and in pregnancy, *Fertil Steril* 95:2163, 2011.
  359. **Chen SL, Wu FR, Luo C, Chen X, Shi XY, Zheng HY, Ni YP**, Combined analysis of endometrial thickness and pattern in predicting outcome of in vitro fertilization and embryo transfer: a retrospective cohort study, *Reprod Biol Endocrinol* 8:30, 2010.
  360. **Kuc P, Kuczynska A, Topczewska M, Tadejko P, Kuczynski W**, The dynamics of endometrial growth and the triple layer appearance in three different controlled ovarian hyperstimulation protocols and their influence on IVF outcomes, *Gynecol Endocrinol* 27:867, 2011.
  361. **Zhao J, Zhang Q, Li Y**, The effect of endometrial thickness and pattern measured by ultrasonography on pregnancy outcomes during IVF-ET cycles, *Reprod Biol Endocrinol* 10:100, 2012.
  362. **Gonen Y, Casper RF**, Prediction of implantation by the sonographic appearance of the endometrium during controlled ovarian stimulation for in vitro fertilization (IVF), *J In Vitro Fert Embryo Transf* 7:146, 1990.
  363. **Noyes N, Liu HC, Sultan K, Schattman G, Rosenwaks Z**, Endometrial thickness appears to be a significant factor in embryo implantation in in-vitro fertilization, *Hum Reprod* 10:919, 1995.
  364. **Fanchin R, Righini C, Ayoubi JM, Olivennes F, de Ziegler D, Frydman R**, New look at endometrial echogenicity: objective computer-assisted measurements predict endometrial receptivity in in vitro fertilization-embryo transfer, *Fertil Steril* 74:274, 2000.

365. **Check JH, Lurie D, Dietterich C, Callan C, Baker A**, Adverse effect of a homogeneous hyperechogenic endometrial sonographic pattern, despite adequate endometrial thickness on pregnancy rates following in-vitro fertilization, *Hum Reprod* 8:1293, 1993.
366. **Check JH, Nowroozi K, Choe J, Lurie D, Dietterich C**, The effect of endometrial thickness and echo pattern on in vitro fertilization outcome in donor oocyte-embryo transfer cycle, *Fertil Steril* 59:72, 1993.
367. **Dechaud H, Bessueille E, Bousquet PJ, Reyftmann L, Hamamah S, Hedon B**, Optimal timing of ultrasonographic and Doppler evaluation of uterine receptivity to implantation, *Reprod Biomed Online* 16:368, 2008.
368. **Kinay T, Tasci Y, Dilbaz S, Cinar O, Demir B, Haberal A**, The relationship between endometrial thickness and pregnancy rates in GnRH antagonist down-regulated ICSI cycles, *Gynecol Endocrinol* 26:833, 2010.
369. **Basir GS, O WS, So WW, Ng EH, Ho PC**, Evaluation of cycle-to-cycle variation of endometrial responsiveness using transvaginal sonography in women undergoing assisted reproduction, *Ultrasound Obstet Gynecol* 19:484, 2002.
370. **Al-Ghamdi A, Coskun S, Al-Hassan S, Al-Rejjal R, Awartani K**, The correlation between endometrial thickness and outcome of in vitro fertilization and embryo transfer (IVF-ET) outcome, *Reprod Biol Endocrinol* 6:37, 2008.
371. **Bozdog G, Esinler I, Yarali H**, The impact of endometrial thickness and texture on intracytoplasmic sperm injection outcome, *J Reprod Med* 54:303, 2009.
372. **Richter KS, Bugge KR, Bromer JG, Levy MJ**, Relationship between endometrial thickness and embryo implantation, based on 1,294 cycles of in vitro fertilization with transfer of two blastocyst-stage embryos, *Fertil Steril* 87:53, 2007.
373. **Yang W, Zhang T, Li Z, Ren X, Huang B, Zhu G, Jin L**, Combined analysis of endometrial thickness and pattern in predicting clinical outcomes of frozen embryo transfer cycles with morphological good-quality blastocyst: A retrospective cohort study, *Medicine (Baltimore)* 97:e9577, 2018.
374. **Bergh C, Hillensjo T, Nilsson L**, Sonographic evaluation of the endometrium in in vitro fertilization IVF cycles. A way to predict pregnancy? *Acta Obstet Gynecol Scand* 71:624, 1992.
375. **Oliveira JB, Baruffi RL, Mauri AL, Petersen CG, Borges MC, Franco JG Jr**, Endometrial ultrasonography as a predictor of pregnancy in an in-vitro fertilization programme after ovarian stimulation and gonadotrophin-releasing hormone and gonadotrophins, *Hum Reprod* 12:2515, 1997.
376. **Ueno J, Oehninger S, Brzyski RG, Acosta AA, Philput CB, Muasher SJ**, Ultrasonographic appearance of the endometrium in natural and stimulated in-vitro fertilization cycles and its correlation with outcome, *Hum Reprod* 6:901, 1991.
377. **Zaidi J, Campbell S, Pittrof R, Tan SL**, Endometrial thickness, morphology, vascular penetration and velocimetry in predicting implantation in an in vitro fertilization program, *Ultrasound Obstet Gynecol* 6:191, 1995.
378. **Khalifa E, Brzyski RG, Oehninger S, Acosta AA, Muasher SJ**, Sonographic appearance of the endometrium: the predictive value for the outcome of in-vitro fertilization in stimulated cycles, *Hum Reprod* 7:677, 1992.
379. **Bassil S**, Changes in endometrial thickness, width, length and pattern in predicting pregnancy outcome during ovarian stimulation in in vitro fertilization, *Ultrasound Obstet Gynecol* 18:258, 2001.
380. **Dickey RP, Olar TT, Curole DN, Taylor SN, Rye PH**, Endometrial pattern and thickness associated with pregnancy outcome after assisted reproduction technologies, *Hum Reprod* 7:418, 1992.
381. **Weissman A, Gotlieb L, Casper RF**, The detrimental effect of increased endometrial thickness on implantation and pregnancy rates and outcome in an in vitro fertilization program, *Fertil Steril* 71:147, 1999.
382. **Dietterich C, Check JH, Choe JK, Nazari A, Lurie D**, Increased endometrial thickness on the day of human chorionic gonadotropin injection does not adversely affect pregnancy or implantation rates following in vitro fertilization-embryo transfer, *Fertil Steril* 77:781, 2002.
383. **Yakin K, Akarsu C, Kahraman S**, Cycle lumping or—sampling a witches' brew? *Fertil Steril* 73:175, 2000.
384. **Sundstrom P**, Establishment of a successful pregnancy following in-vitro fertilization with an endometrial thickness of no more than 4 mm, *Hum Reprod* 13:1550, 1998.

385. **Amin B, Cho M, Shamonki M**, Establishment of a successful pregnancy and term delivery following ovulation induction with a maximum endometrial thickness of 3 mm, *J Fertil In Vitro IVF Worldw Reprod Med Genet Stem Cell Biol* 2:114, 2012.
386. **Kasius A, Smit JG, Torrance HL, Eijkemans MJ, Mol BW, Opmeer BC, Broekmans FJ**, Endometrial thickness and pregnancy rates after IVF: a systematic review and meta-analysis, *Hum Reprod Update* 20:530, 2014.
387. **De Geyter C, Schmitter M, De Geyter M, Nieschlag E, Holzgreve W, Schneider HP**, Prospective evaluation of the ultrasound appearance of the endometrium in a cohort of 1,186 infertile women, *Fertil Steril* 73:106, 2000.
388. **Youssef MA, Abou-Setta AM, Lam WS**, Recombinant versus urinary human chorionic gonadotrophin for final oocyte maturation triggering in IVF and ICSI cycles, *Cochrane Database Syst Rev* (4):CD003719, 2016.
389. **Humaidan P, Kol S, Papanikolaou EG; Copenhagen GnRH Agonist Triggering Workshop Group**, GnRH agonist for triggering of final oocyte maturation: time for a change of practice? *Hum Reprod Update* 17:510, 2011.
390. **Turkgeldi E, Turkgeldi L, Seyhan A, Ata B**, Gonadotropin-releasing hormone agonist triggering of oocyte maturation in assisted reproductive technology cycles, *Turk J Obstet Gynecol* 12:96, 2015.
391. **Lamb JD, Shen S, McCulloch C, Jalalian L, Cedars MI, Rosen MP**, Follicle-stimulating hormone administered at the time of human chorionic gonadotropin trigger improves oocyte developmental competence in in vitro fertilization cycles: a randomized, double-blind, placebo-controlled trial, *Fertil Steril* 95:1655, 2011.
392. **Vermeiden JP, Roseboom TJ, Goverde AJ, Suchartwatnachai C, Schoute E, Braat DD, Schats R**, An artificially induced follicle stimulating hormone surge at the time of human chorionic gonadotrophin administration in controlled ovarian stimulation cycles has no effect on cumulus expansion, fertilization rate, embryo quality and implantation rate, *Hum Reprod* 12:1399, 1997.
393. **Zhou X, Guo P, Chen X, Ye D, Liu Y, Chen S**, Comparison of dual trigger with combination GnRH agonist and hCG versus hCG alone trigger of oocyte maturation for normal ovarian responders, *Int J Gynaecol Obstet* 141:327, 2018.
394. **Lin MH, Wu FS, Lee RK, Li SH, Lin SY, Hwu YM**, Dual trigger with combination of gonadotropin-releasing hormone agonist and human chorionic gonadotropin significantly improves the live-birth rate for normal responders in GnRH-antagonist cycles, *Fertil Steril* 100:1296, 2013.
395. **Li S, Zhou D, Yin T, Xu W, Xie Q, Cheng D, Yang J**, Dual trigger of triptorelin and HCG optimizes clinical outcome for high ovarian responder in GnRH-antagonist protocols, *Oncotarget* 9:5337, 2018.
396. **Lu X, Hong Q, Sun L, Chen Q, Fu Y, Ai A, Lyu Q, Kuang Y**, Dual trigger for final oocyte maturation improves the oocyte retrieval rate of suboptimal responders to gonadotropin-releasing hormone agonist, *Fertil Steril* 106:1356, 2016.
397. **Zhang J, Wang Y, Mao X, Chen Q, Hong Q, Cai R, Zhang S, Kuang Y**, Dual trigger of final oocyte maturation in poor ovarian responders undergoing IVF/ICSI cycles, *Reprod Biomed Online* 35:701, 2017.
398. **Oliveira SA, Calsavara VF, Cortes GC**, Final oocyte maturation in assisted reproduction with human chorionic gonadotropin and gonadotropin-releasing hormone agonist (Dual Trigger), *JBRA Assist Reprod* 20:246, 2016.
399. **Seval MM, Ozmen B, Atabekoglu C, Sukur YE, Simsir C, Kan O, Sonmezer M**, Dual trigger with gonadotropin-releasing hormone agonist and recombinant human chorionic gonadotropin improves in vitro fertilization outcome in gonadotropin-releasing hormone antagonist cycles, *J Obstet Gynaecol Res* 42:1146, 2016.
400. **Youssef MA, Van der Veen F, Al-Inany HG, Mochtar MH, Griesinger G, Nagi Mohesen M, Aboufoutouh I, van Wely M**, Gonadotropin-releasing hormone agonist versus HCG for oocyte triggering in antagonist-assisted reproductive technology, *Cochrane Database Syst Rev* (10):CD008046, 2014.
401. **Venetis CA, Kolibianakis EM, Bosdou JK, Lainas GT, Sfountouris IA, Tarlatzis BC, Lainas TG**, Estimating the net effect of progesterone elevation on the day of hCG on live birth rates after IVF: a cohort analysis of 3296 IVF cycles, *Hum Reprod* 30:684, 2015.
402. **Venetis CA, Kolibianakis EM, Bosdou JK, Tarlatzis BC**, Progesterone elevation and probability of



- pregnancy after IVF: a systematic review and meta-analysis of over 60 000 cycles, *Hum Reprod Update* 19:433, 2013.
403. **Esteves SC, Khastgir G, Shah J, Murdia K, Gupta SM, Rao DG, Dash S, Ingale K, Patil M, Moideen K, Thakor P, Dewda P**, Association between progesterone elevation on the day of human chorionic gonadotropin trigger and pregnancy outcomes after fresh embryo transfer in in vitro fertilization/intracytoplasmic sperm injection cycles, *Front Endocrinol (Lausanne)* 9:201, 2018.
  404. **Xu B, Li Z, Zhang H, Jin L, Li Y, Ai J, Zhu G**, Serum progesterone level effects on the outcome of in vitro fertilization in patients with different ovarian response: an analysis of more than 10,000 cycles, *Fertil Steril* 97:1321.e1, 2012.
  405. **Racca A, Santos-Ribeiro S, De Munck N, Mackens S, Drakopoulos P, Camus M, Verheyen G, Tournaye H, Blockeel C**, Impact of late-follicular phase elevated serum progesterone on cumulative live birth rates: is there a deleterious effect on embryo quality? *Hum Reprod* 33:860, 2018.
  406. **Ata B, Seli E**, A universal freeze all strategy: why it is not warranted, *Curr Opin Obstet Gynecol* 29:136, 2017.
  407. **Smitz J, Camus M, Devroey P, Erard P, Wisanto A, Van Steirteghem AC**, Incidence of severe ovarian hyperstimulation syndrome after GnRH agonist/HMG superovulation for in-vitro fertilization, *Hum Reprod* 5:933, 1990.
  408. **MacDougall MJ, Tan SL, Jacobs HS**, In-vitro fertilization and the ovarian hyperstimulation syndrome, *Hum Reprod* 7:597, 1992.
  409. **Rizk B, Smitz J**, Ovarian hyperstimulation syndrome after superovulation using GnRH agonists for IVF and related procedures, *Hum Reprod* 7:320, 1992.
  410. **Chen ZJ, Shi Y, Sun Y, Zhang B, Liang X, Cao Y, Yang J, Liu J, Wei D, Weng N, Tian L, Hao C, Yang D, Zhou F, Shi J, Xu Y, Li J, Yan J, Qin Y, Zhao H, Zhang H, Legro RS**, Fresh versus frozen embryos for infertility in the polycystic ovary syndrome, *N Engl J Med* 375:523, 2016.
  411. **Shapiro BS, Daneshmand ST, Garner FC, Aguirre M, Hudson C, Thomas S**, Evidence of impaired endometrial receptivity after ovarian stimulation for in vitro fertilization: a prospective randomized trial comparing fresh and frozen-thawed embryo transfers in high responders, *Fertil Steril* 96:516, 2011.
  412. **Dahan MH, Tannus S, Seyhan A, Tan SL, Ata B**, Combined modalities for the prevention of ovarian hyperstimulation syndrome following an excessive response to stimulation, *Gynecol Endocrinol* 34:252, 2018.
  413. **Ferraretti AP, La Marca A, Fauser BC, Tarlatzis B, Nargund G, Gianaroli L; ESHRE working group on Poor Ovarian Response Definition**, ESHRE consensus on the definition of “poor response” to ovarian stimulation for in vitro fertilization: the Bologna criteria, *Hum Reprod* 26:1616, 2011.
  414. **Ferraretti AP, Gianaroli L**, The Bologna criteria for the definition of poor ovarian responders: is there a need for revision? *Hum Reprod* 29:1842, 2014.
  415. **Venetis CA**, The Bologna criteria for poor ovarian response: the good, the bad and the way forward, *Hum Reprod* 29:1839, 2014.
  416. **Boza A, Oguz SY, Misirlioglu S, Yakin K, Urman B**, Utilization of the Bologna criteria: a promise unfulfilled? A review of published and unpublished/ongoing trials, *Fertil Steril* 109:104.e2, 2018.
  417. **Kyrou D, Kolibianakis EM, Venetis CA, Papanikolaou EG, Bontis J, Tarlatzis BC**, How to improve the probability of pregnancy in poor responders undergoing in vitro fertilization: a systematic review and meta-analysis, *Fertil Steril* 91:749, 2009.
  418. **Hill MJ, McWilliams GD, Miller KA, Scott RT, Jr., Frattarelli JL**, A luteal estradiol protocol for anticipated poor-responder patients may improve delivery rates, *Fertil Steril* 91:739, 2009.
  419. **Arslan M, Bocca S, Mirkin S, Barroso G, Stadtmauer L, Oehninger S**, Controlled ovarian hyperstimulation protocols for in vitro fertilization: two decades of experience after the birth of Elizabeth Carr, *Fertil Steril* 84:555, 2005.
  420. **Padilla SL, Dugan K, Maruschak V, Shalika S, Smith RD**, Use of the flare-up protocol with high dose human follicle stimulating hormone and human menopausal gonadotropins for in vitro fertilization in poor responders, *Fertil Steril* 65:796, 1996.
  421. **Garcia JE, Padilla SL, Bayati J, Baramki TA**, Follicular phase gonadotropin-releasing hormone agonist and human gonadotropins: a better alternative for ovulation induction in in vitro fertilization, *Fertil Steril* 53:302,

1990.

422. **San Roman GA, Surrey ES, Judd HL, Kerin JF**, A prospective randomized comparison of luteal phase versus concurrent follicular phase initiation of gonadotropin-releasing hormone agonist for in vitro fertilization, *Fertil Steril* 58:744, 1992.
423. **Gelety TJ, Pearlstone AC, Surrey ES**, Short-term endocrine response to gonadotropin-releasing hormone agonist initiated in the early follicular, midluteal, or late luteal phase in normally cycling women, *Fertil Steril* 64:1074, 1995.
424. **Blockeel C, Baumgarten M, De Vos M, Verheyen G, Devroey P**, Administration of GnRH antagonists in case of elevated progesterone at initiation of the cycle: a prospective cohort study, *Curr Pharm Biotechnol* 12:423, 2011.
425. **Kolibianakis EM, Zikopoulos K, Smitz J, Camus M, Tournaye H, Van Steirteghem AC, Devroey P**, Elevated progesterone at initiation of stimulation is associated with a lower ongoing pregnancy rate after IVF using GnRH antagonists, *Hum Reprod* 19:1525, 2004.
426. **Loumaye E, Vankrieken L, Depreester S, Psalti I, de Cooman S, Thomas K**, Hormonal changes induced by short-term administration of gonadotropin-releasing hormone agonist during ovarian hyperstimulation for in vitro fertilization and their consequences for embryo development, *Fertil Steril* 51:105, 1989.
427. **Surrey ES, Bower J, Hill DM, Ramsey J, Surrey MW**, Clinical and endocrine effects of a microdose GnRH agonist flare regimen administered to poor responders who are undergoing in vitro fertilization, *Fertil Steril* 69:419, 1998.
428. **Gonen Y, Jacobson W, Casper RF**, Gonadotropin suppression with oral contraceptives before in vitro fertilization, *Fertil Steril* 53:282, 1990.
429. **Cedrin-Durnerin I, Bulwa S, Herve F, Martin-Pont B, Uzan M, Hugues JN**, The hormonal flare-up following gonadotrophin-releasing hormone agonist administration is influenced by a progestogen pretreatment, *Hum Reprod* 11:1859, 1996.
430. **Xiao J, Chang S, Chen S**, The effectiveness of gonadotropin-releasing hormone antagonist in poor ovarian responders undergoing in vitro fertilization: a systematic review and meta-analysis, *Fertil Steril* 100:1594.e1, 2013.
431. **Pu D, Wu J, Liu J**, Comparisons of GnRH antagonist versus GnRH agonist protocol in poor ovarian responders undergoing IVF, *Hum Reprod* 26:2742, 2011.
432. **Matikainen T, Ding YQ, Vergara M, Huhtaniemi I, Couzinet B, Schaison G**, Differing responses of plasma bioactive and immunoreactive follicle-stimulating hormone and luteinizing hormone to gonadotropin-releasing hormone antagonist and agonist treatments in postmenopausal women, *J Clin Endocrinol Metab* 75:820, 1992.
433. **Reissmann T, Felberbaum R, Diedrich K, Engel J, Comaru-Schally AM, Schally AV**, Development and applications of luteinizing hormone-releasing hormone antagonists in the treatment of infertility: an overview, *Hum Reprod* 10:1974, 1995.
434. **Olivennes F, Cunha-Filho JS, Fanchin R, Bouchard P, Frydman R**, The use of GnRH antagonists in ovarian stimulation, *Hum Reprod Update* 8:279, 2002.
435. **Albano C, Felberbaum RE, Smitz J, Riethmuller-Winzen H, Engel J, Diedrich K, Devroey P**, Ovarian stimulation with HMG: results of a prospective randomized phase III European study comparing the luteinizing hormone-releasing hormone (LHRH)-antagonist cetrorelix and the LHRH-agonist buserelin. European Cetrorelix Study Group, *Hum Reprod* 15:526, 2000.
436. **Akman MA, Erden HF, Tosun SB, Bayazit N, Aksoy E, Bahceci M**, Comparison of agonistic flare-up-protocol and antagonistic multiple dose protocol in ovarian stimulation of poor responders: results of a prospective randomized trial, *Hum Reprod* 16:868, 2001.
437. **Felberbaum RE, Albano C, Ludwig M, Riethmuller-Winzen H, Grigat M, Devroey P, Diedrich K**, Ovarian stimulation for assisted reproduction with HMG and concomitant midcycle administration of the GnRH antagonist cetrorelix according to the multiple dose protocol: a prospective uncontrolled phase III study, *Hum Reprod* 15:1015, 2000.
438. **Ludwig M, Felberbaum RE, Devroey P, Albano C, Riethmuller-Winzen H, Schuler A, Engel W**,

- Diedrich K**, Significant reduction of the incidence of ovarian hyperstimulation syndrome (OHSS) by using the LHRH antagonist Cetrorelix (Cetrotide) in controlled ovarian stimulation for assisted reproduction, *Arch Gynecol Obstet* 264:29, 2000.
439. **de Jong D, Macklon NS, Eijkemans MJ, Mannaerts BM, Coelingh Bennink HJ, Fauser BC; Ganirelix Dose-Finding Study Group**, Dynamics of the development of multiple follicles during ovarian stimulation for in vitro fertilization using recombinant follicle-stimulating hormone (Puregon) and various doses of the gonadotropin-releasing hormone antagonist ganirelix (Orgalutran/Antagon), *Fertil Steril* 75:688, 2001.
440. **Toftager M, Bogstad J, Bryndorf T, Lossl K, Roskaer J, Holland T, Praetorius L, Zedeler A, Nilas L, Pinborg A**, Risk of severe ovarian hyperstimulation syndrome in GnRH antagonist versus GnRH agonist protocol: RCT including 1050 first IVF/ICSI cycles, *Hum Reprod* 31:1253, 2016.
441. **Al-Inany HG, Youssef MA, Aboulghar M, Broekmans F, Sterrenburg M, Smit J, Abou-Setta AM**, Gonadotrophin-releasing hormone antagonists for assisted reproductive technology, *Cochrane Database Syst Rev* (5):CD001750, 2011.
442. **Toftager M, Bogstad J, Lossl K, Praetorius L, Zedeler A, Bryndorf T, Nilas L, Pinborg A**, Cumulative live birth rates after one ART cycle including all subsequent frozen-thaw cycles in 1050 women: secondary outcome of an RCT comparing GnRH-antagonist and GnRH-agonist protocols, *Hum Reprod* 32: 556, 2017.
443. **Al-Inany HG, Abou-Setta AM, Aboulghar M**, Gonadotrophin-releasing hormone antagonists for assisted conception, *Cochrane Database Syst Rev* (3):CD001750, 2006.
444. **Albano C, Smitz J, Camus M, Riethmuller-Winzen H, Van Steirteghem A, Devroey P**, Comparison of different doses of gonadotropin-releasing hormone antagonist Cetrorelix during controlled ovarian hyperstimulation, *Fertil Steril* 67:917, 1997.
445. **Diedrich K, Diedrich C, Santos E, Zoll C, al-Hasani S, Reissmann T, Krebs D, Klingmuller D**, Suppression of the endogenous luteinizing hormone surge by the gonadotrophin-releasing hormone antagonist Cetrorelix during ovarian stimulation, *Hum Reprod* 9:788, 1994.
446. **Ludwig M, Katalinic A, Banz C, Schroder AK, Loning M, Weiss JM, Diedrich K**, Tailoring the GnRH antagonist cetrorelix acetate to individual patients' needs in ovarian stimulation for IVF: results of a prospective, randomized study, *Hum Reprod* 17:2842, 2002.
447. **Klipstein S, Reindollar RH, Regan MM, Alper MM**, Initiation of the gonadotropin-releasing hormone antagonist ganirelix for in vitro fertilization cycles in which the lead follicle is >14 mm, *Fertil Steril* 81:714, 2004.
448. **Olivennes F, Belaisch-Allart J, Empeaire JC, Dechaud H, Alvarez S, Moreau L, Nicollet B, Zorn JR, Bouchard P, Frydman R**, Prospective, randomized, controlled study of in vitro fertilization-embryo transfer with a single dose of a luteinizing hormone-releasing hormone (LH-RH) antagonist (cetrorelix) or a depot formula of an LH-RH agonist (triptorelin), *Fertil Steril* 73:314, 2000.
449. **Olivennes F, Diedrich K, Frydman R, Felberbaum RE, Howles CM; Cerotide Multiple Dose International Study Group; Cetrotide Single Dose International Study Group**, Safety and efficacy of a 3 mg dose of the GnRH antagonist cetrorelix in preventing premature LH surges: report of two large multicentre, multinational, phase IIIb clinical experiences, *Reprod Biomed Online* 6:432, 2003.
450. **Olivennes F, Alvarez S, Bouchard P, Fanchin R, Salat-Baroux J, Frydman R**, The use of a GnRH antagonist (Cetrorelix) in a single dose protocol in IVF-embryo transfer: a dose finding study of 3 versus 2 mg, *Hum Reprod* 13:2411, 1998.
451. **Fanchin R, Cunha-Filho JS, Schonauer LM, Kadoch IJ, Cohen-Bacri P, Frydman R**, Coordination of early antral follicles by luteal estradiol administration provides a basis for alternative controlled ovarian hyperstimulation regimens, *Fertil Steril* 79:316, 2003.
452. **Griesinger G, Kolibianakis EM, Venetis C, Diedrich K, Tarlatzis B**, Oral contraceptive pretreatment significantly reduces ongoing pregnancy likelihood in gonadotropin-releasing hormone antagonist cycles: an updated meta-analysis, *Fertil Steril* 94:2382, 2010.
453. **Farquhar C, Rombauts L, Kremer JA, Lethaby A, Ayeleke RO**, Oral contraceptive pill, progestogen or oestrogen pretreatment for ovarian stimulation protocols for women undergoing assisted reproductive techniques, *Cochrane Database Syst Rev* (5):CD006109, 2017.
454. **Aslan K, Avci B, Uncu G, Saribal S, Ata B**, Scheduling GnRH antagonist cycles by a short course of oral

- estradiol administration during early follicular phase: a comparative study with non-scheduled cycles, *Gynecol Endocrinol* 31:465, 2015.
455. **Fanchin R, Salomon L, Castelo-Branco A, Olivennes F, Frydman N, Frydman R**, Luteal estradiol pre-treatment coordinates follicular growth during controlled ovarian hyperstimulation with GnRH antagonists, *Hum Reprod* 18:2698, 2003.
456. **de Ziegler D, Jaaskelainen AS, Brioschi PA, Fanchin R, Bulletti C**, Synchronization of endogenous and exogenous FSH stimuli in controlled ovarian hyperstimulation (COH), *Hum Reprod* 13:561, 1998.
457. **Fanchin R, Cunha-Filho JS, Schonauer LM, Righini C, de Ziegler D, Frydman R**, Luteal estradiol administration strengthens the relationship between day 3 follicle-stimulating hormone and inhibin B levels and ovarian follicular status, *Fertil Steril* 79:585, 2003.
458. **Itskovitz-Eldor J, Kol S, Mannaerts B**, Use of a single bolus of GnRH agonist triptorelin to trigger ovulation after GnRH antagonist ganirelix treatment in women undergoing ovarian stimulation for assisted reproduction, with special reference to the prevention of ovarian hyperstimulation syndrome: preliminary report: short communication, *Hum Reprod* 15:1965, 2000.
459. **Fausser BC, de Jong D, Olivennes F, Wramsby H, Tay C, Itskovitz-Eldor J, van Hooren HG**, Endocrine profiles after triggering of final oocyte maturation with GnRH agonist after cotreatment with the GnRH antagonist ganirelix during ovarian hyperstimulation for in vitro fertilization, *J Clin Endocrinol Metab* 87:709, 2002.
460. **Kolibianakis E, Bourgain C, Albano C, Osmanagaoglu K, Smitz J, Van Steirteghem A, Devroey P**, Effect of ovarian stimulation with recombinant follicle-stimulating hormone, gonadotropin releasing hormone antagonists, and human chorionic gonadotropin on endometrial maturation on the day of oocyte pick-up, *Fertil Steril* 78:1025, 2002.
461. **Kolibianakis EM, Albano C, Kahn J, Camus M, Tournaye H, Van Steirteghem AC, Devroey P**, Exposure to high levels of luteinizing hormone and estradiol in the early follicular phase of gonadotropin-releasing hormone antagonist cycles is associated with a reduced chance of pregnancy, *Fertil Steril* 79:873, 2003.
462. **Kolibianakis EM, Albano C, Camus M, Tournaye H, Van Steirteghem AC, Devroey P**, Relationship between LH and oestradiol in IVF cycles before GnRH antagonist initiation, *Reprod Biomed Online* 7:190, 2003.
463. **Kolibianakis E, Zikopoulos K, Albano C, Camus M, Tournaye H, Van Steirteghem A, Devroey P**, Reproductive outcome of polycystic ovarian syndrome patients treated with GnRH antagonists and recombinant FSH for IVF/ICSI, *Reprod Biomed Online* 7:313, 2003.
464. **Sunkara SK, Tuthill J, Khairy M, El-Toukhy T, Coomarasamy A, Khalaf Y, Braude P**, Pituitary suppression regimens in poor responders undergoing IVF treatment: a systematic review and meta-analysis, *Reprod Biomed Online* 15:539, 2007.
465. **Gonen Y, Balakier H, Powell W, Casper RF**, Use of gonadotropin-releasing hormone agonist to trigger follicular maturation for in vitro fertilization, *J Clin Endocrinol Metab* 71:918, 1990.
466. **Imoedemhe DA, Chan RC, Sigue AB, Pacpaco EL, Olazo AB**, A new approach to the management of patients at risk of ovarian hyperstimulation in an in-vitro fertilization programme, *Hum Reprod* 6:1088, 1991.
467. **Pellicer A, Albert C, Mercader A, Bonilla-Musoles F, Remohi J, Simon C**, The pathogenesis of ovarian hyperstimulation syndrome: in vivo studies investigating the role of interleukin-1beta, interleukin-6, and vascular endothelial growth factor, *Fertil Steril* 71:482, 1999.
468. **Wang TH, Horng SG, Chang CL, Wu HM, Tsai YJ, Wang HS, Soong YK**, Human chorionic gonadotropin-induced ovarian hyperstimulation syndrome is associated with up-regulation of vascular endothelial growth factor, *J Clin Endocrinol Metab* 87:3300, 2002.
469. **Yamamoto S, Konishi I, Tsuruta Y, Nanbu K, Mandai M, Kuroda H, Matsushita K, Hamid AA, Yura Y, Mori T**, Expression of vascular endothelial growth factor (VEGF) during folliculogenesis and corpus luteum formation in the human ovary, *Gynecol Endocrinol* 11:371, 1997.
470. **Scotti L, Irusta G, Abramovich D, Tesone M, Parborell F**, Administration of a gonadotropin-releasing hormone agonist affects corpus luteum vascular stability and development and induces luteal apoptosis in a rat

model of ovarian hyperstimulation syndrome, *Mol Cell Endocrinol* 335:116, 2011.

471. **Borgbo T, Povlsen BB, Andersen CY, Borup R, Humaidan P, Grondahl ML**, Comparison of gene expression profiles in granulosa and cumulus cells after ovulation induction with either human chorionic gonadotropin or a gonadotropin-releasing hormone agonist trigger, *Fertil Steril* 100:994, 2013.
472. **Humaidan P, Breckjaer HE, Bungum L, Bungum M, Grondahl ML, Westergaard L, Andersen CY**, GnRH agonist (buserelin) or hCG for ovulation induction in GnRH antagonist IVF/ICSI cycles: a prospective randomized study, *Hum Reprod* 20:1213, 2005.
473. **Kolibianakis EM, Schultze-Mosgau A, Schroer A, van Steirteghem A, Devroey P, Diedrich K, Griesinger G**, A lower ongoing pregnancy rate can be expected when GnRH agonist is used for triggering final oocyte maturation instead of HCG in patients undergoing IVF with GnRH antagonists, *Hum Reprod* 20:2887, 2005.
474. **Acevedo B, Gomez-Palomares JL, Ricciarelli E, Hernandez ER**, Triggering ovulation with gonadotropin-releasing hormone agonists does not compromise embryo implantation rates, *Fertil Steril* 86:1682, 2006.
475. **Griesinger G, Berndt H, Schultz L, Depenbusch M, Schultze-Mosgau A**, Cumulative live birth rates after GnRH-agonist triggering of final oocyte maturation in patients at risk of OHSS: a prospective, clinical cohort study, *Eur J Obstet Gynecol Reprod Biol* 149:190, 2010.
476. **Herrero L, Pareja S, Losada C, Cobo AC, Pellicer A, Garcia-Velasco JA**, Avoiding the use of human chorionic gonadotropin combined with oocyte vitrification and GnRH agonist triggering versus coasting: a new strategy to avoid ovarian hyperstimulation syndrome, *Fertil Steril* 95:1137, 2011.
477. **Babayof R, Margalioth EJ, Huleihel M, Amash A, Zylber-Haran E, Gal M, Brooks B, Mimoni T, Eldar-Geva T**, Serum inhibin A, VEGF and TNFalpha levels after triggering oocyte maturation with GnRH agonist compared with HCG in women with polycystic ovaries undergoing IVF treatment: a prospective randomized trial, *Hum Reprod* 21:1260, 2006.
478. **Engmann L, Siano L, Schmidt D, Nulsen J, Maier D, Benadiva C**, GnRH agonist to induce oocyte maturation during IVF in patients at high risk of OHSS, *Reprod Biomed Online* 13:639, 2006.
479. **Chen SL, Ye DS, Chen X, Yang XH, Zheng HY, Tang Y, He YX, Guo W**, Circulating luteinizing hormone level after triggering oocyte maturation with GnRH agonist may predict oocyte yield in flexible GnRH antagonist protocol, *Hum Reprod* 27:1351, 2012.
480. **Kummer NE, Feinn RS, Griffin DW, Nulsen JC, Benadiva CA, Engmann LL**, Predicting successful induction of oocyte maturation after gonadotropin-releasing hormone agonist (GnRHa) trigger, *Hum Reprod* 28:152, 2013.
481. **Humaidan P, Bungum L, Bungum M, Yding Andersen C**, Rescue of corpus luteum function with peri-ovulatory HCG supplementation in IVF/ICSI GnRH antagonist cycles in which ovulation was triggered with a GnRH agonist: a pilot study, *Reprod Biomed Online* 13:173, 2006.
482. **Humaidan P, Ejdrup Breckjaer H, Westergaard LG, Yding Andersen C**, 1,500 IU human chorionic gonadotropin administered at oocyte retrieval rescues the luteal phase when gonadotropin-releasing hormone agonist is used for ovulation induction: a prospective, randomized, controlled study, *Fertil Steril* 93:847, 2010.
483. **Humaidan P, Polyzos NP, Alsbjerg B, Erb K, Mikkelsen AL, Elbaek HO, Papanikolaou EG, Andersen CY**, GnRHa trigger and individualized luteal phase hCG support according to ovarian response to stimulation: two prospective randomized controlled multi-centre studies in IVF patients, *Hum Reprod* 28:2511, 2013.
484. **Humaidan P**, Luteal phase rescue in high-risk OHSS patients by GnRHa triggering in combination with low-dose HCG: a pilot study, *Reprod Biomed Online* 18:630, 2009.
485. **Radesic B, Tremellen K**, Oocyte maturation employing a GnRH agonist in combination with low-dose hCG luteal rescue minimizes the severity of ovarian hyperstimulation syndrome while maintaining excellent pregnancy rates, *Hum Reprod* 26:3437, 2011.
486. **Fatemi HM, Popovic-Todorovic B, Humaidan P, Kol S, Banker M, Devroey P, Garcia-Velasco JA**, Severe ovarian hyperstimulation syndrome after gonadotropin-releasing hormone (GnRH) agonist trigger and "freeze-all" approach in GnRH antagonist protocol, *Fertil Steril* 101:1008, 2014.
487. **Gurbuz AS, Gode F, Ozcimen N, Isik AZ**, Gonadotropin-releasing hormone agonist trigger and freeze-all

strategy does not prevent severe ovarian hyperstimulation syndrome: a report of three cases, *Reprod Biomed Online* 29:541, 2014.

488. **Seyhan A, Ata B, Polat M, Son WY, Yarali H, Dahan MH**, Severe early ovarian hyperstimulation syndrome following GnRH agonist trigger with the addition of 1500 IU hCG, *Hum Reprod* 28:2522, 2013.
489. **Oktay K, Turkcuoglu I, Rodriguez-Wallberg KA**, GnRH agonist trigger for women with breast cancer undergoing fertility preservation by aromatase inhibitor/FSH stimulation, *Reprod Biomed Online* 20:783, 2010.
490. **Baerwald AR, Adams GP, Pierson RA**, Ovarian antral folliculogenesis during the human menstrual cycle: a review, *Hum Reprod Update* 18:73, 2012.
491. **Sonmezer M, Turkcuoglu I, Coskun U, Oktay K**, Random-start controlled ovarian hyperstimulation for emergency fertility preservation in letrozole cycles, *Fertil Steril* 95:2125.e9, 2011.
492. **Cakmak H, Rosen MP**, Random-start ovarian stimulation in patients with cancer, *Curr Opin Obstet Gynecol* 27:215, 2015.
493. **Kim JH, Kim SK, Lee HJ, Lee JR, Jee BC, Suh CS, Kim SH**, Efficacy of random-start controlled ovarian stimulation in cancer patients, *J Korean Med Sci* 30:290, 2015.
494. **Kuang Y, Chen Q, Hong Q, Lyu Q, Ai A, Fu Y, Shoham Z**, Double stimulations during the follicular and luteal phases of poor responders in IVF/ICSI programmes (Shanghai protocol), *Reprod Biomed Online* 29:684, 2014.
495. **Kuang Y, Hong Q, Chen Q, Lyu Q, Ai A, Fu Y, Shoham Z**, Luteal-phase ovarian stimulation is feasible for producing competent oocytes in women undergoing in vitro fertilization/intracytoplasmic sperm injection treatment, with optimal pregnancy outcomes in frozen-thawed embryo transfer cycles, *Fertil Steril* 101:105, 2014.
496. **Boots CE, Meister M, Cooper AR, Hardi A, Jungheim ES**, Ovarian stimulation in the luteal phase: systematic review and meta-analysis, *J Assist Reprod Genet* 33:971, 2016.
497. **Liu C, Jiang H, Zhang W, Yin H**, Double ovarian stimulation during the follicular and luteal phase in women  $\geq 38$  years: a retrospective case-control study, *Reprod Biomed Online* 35:678, 2017.
498. **Ubaldi FM, Capalbo A, Vaiarelli A, Cimadomo D, Colamaria S, Alviggi C, Trabucco E, Venturella R, Vajta G, Rienzi L**, Follicular versus luteal phase ovarian stimulation during the same menstrual cycle (DuoStim) in a reduced ovarian reserve population results in a similar euploid blastocyst formation rate: new insight in ovarian reserve exploitation, *Fertil Steril* 105:1488.e1, 2016.
499. **Chen H, Wang Y, Lyu Q, Ai A, Fu Y, Tian H, Cai R, Hong Q, Chen Q, Shoham Z, Kuang Y**, Comparison of live-birth defects after luteal-phase ovarian stimulation vs. conventional ovarian stimulation for in vitro fertilization and vitrified embryo transfer cycles, *Fertil Steril* 103:1194.e2, 2015.
500. **Dimitry ES, Oskarsson T, Conaghan J, Margara R, Winston RM**, Beneficial effects of a 24 h delay in human chorionic gonadotrophin administration during in-vitro fertilization treatment cycles, *Hum Reprod* 6:944, 1991.
501. **Tan SL, Balen A, el Hussein E, Mills C, Campbell S, Yovich J, Jacobs HS**, A prospective randomized study of the optimum timing of human chorionic gonadotropin administration after pituitary desensitization in in vitro fertilization, *Fertil Steril* 57:1259, 1992.
502. **Jamieson ME, Fleming R, Kader S, Ross KS, Yates RW, Coutts JR**, In vivo and in vitro maturation of human oocytes: effects on embryo development and polyspermic fertilization, *Fertil Steril* 56:93, 1991.
503. **Tarlatzis BC**, Oocyte collection and quality, *Assist Reprod Rev* 2:16, 1992.
504. **Mansour RT, Aboulghar MA, Serour GI**, Study of the optimum time for human chorionic gonadotropin-ovum pickup interval in in vitro fertilization, *J Assist Reprod Genet* 11:478, 1994.
505. **Kwan I, Bhattacharya S, Knox F, McNeil A**, Conscious sedation and analgesia for oocyte retrieval during in vitro fertilisation procedures, *Cochrane Database Syst Rev* (3):CD004829, 2005.
506. **Dicker D, Ashkenazi J, Feldberg D, Levy T, Dekel A, Ben-Rafael Z**, Severe abdominal complications after transvaginal ultrasonographically guided retrieval of oocytes for in vitro fertilization and embryo transfer, *Fertil Steril* 59:1313, 1993.
507. **Bennett SJ, Waterstone JJ, Cheng WC, Parsons J**, Complications of transvaginal ultrasound-directed follicle aspiration: a review of 2670 consecutive procedures, *J Assist Reprod Genet* 10:72, 1993.

508. **van Os HC, Roozenburg BJ, Janssen-Caspers HA, Leerentveld RA, Scholtes MC, Zeilmaker GH, Alberda AT**, Vaginal disinfection with povidon iodine and the outcome of in-vitro fertilization, *Hum Reprod* 7:349, 1992.
509. **Waterstone JJ, Parsons JH**, A prospective study to investigate the value of flushing follicles during transvaginal ultrasound-directed follicle aspiration, *Fertil Steril* 57:221, 1992.
510. **Levy G, Hill MJ, Ramirez CI, Correa L, Ryan ME, DeCherney AH, Levens ED, Whitcomb BW**, The use of follicle flushing during oocyte retrieval in assisted reproductive technologies: a systematic review and meta-analysis, *Hum Reprod* 27:2373, 2012.
511. **Georgiou EX, Melo P, Brown J, Granne IE**, Follicular flushing during oocyte retrieval in assisted reproductive techniques, *Cochrane Database Syst Rev* (4):CD004634, 2018.
512. **Tan SL, Waterstone J, Wren M, Parsons J**, A prospective randomized study comparing aspiration only with aspiration and flushing for transvaginal ultrasound-directed oocyte recovery, *Fertil Steril* 58:356, 1992.
513. **Haydardedeoglu B, Gjemalaj F, Aytac PC, Kilicdag EB**, Direct aspiration versus follicular flushing in poor responders undergoing intracytoplasmic sperm injection: a randomised controlled trial, *BJOG* 124:1190, 2017.
514. **Wisanto A, Bollen N, Camus M, De Grauwe E, Devroey P, Van Steirteghem AC**, Effect of transuterine puncture during transvaginal oocyte retrieval on the results of human in-vitro fertilization, *Hum Reprod* 4:790, 1989.
515. **Ben-Shlomo I, Schiff E, Levrant D, Ben-Rafael Z, Mashiach S, Dor J**, Failure of oocyte retrieval during in vitro fertilization: a sporadic event rather than a syndrome, *Fertil Steril* 55:324, 1991.
516. **Quintans CJ, Donaldson MJ, Blanco LA, Pasqualini RS**, Empty follicle syndrome due to human errors: its occurrence in an in-vitro fertilization programme, *Hum Reprod* 13:2703, 1998.
517. **Aktas M, Beckers NG, van Inzen WG, Verhoeff A, de Jong D**, Oocytes in the empty follicle: a controversial syndrome, *Fertil Steril* 84:1643, 2005.
518. **Khalaf Y, Braude P**, "Curing" empty follicle syndrome, *Hum Reprod* 12:1601, 1997.
519. **Zegers-Hochschild F, Fernandez E, Mackenna A, Fabres C, Altieri E, Lopez T**, The empty follicle syndrome: a pharmaceutical industry syndrome, *Hum Reprod* 10:2262, 1995.
520. **Ndukwe G, Thornton S, Fishel S, Dowell K, al-Hassan S, Hunter A**, Predicting empty follicle syndrome, *Fertil Steril* 66:845, 1996.
521. **Uygur D, Alkan RN, Batuoglu S**, Recurrent empty follicle syndrome, *J Assist Reprod Genet* 20:390, 2003.
522. **Castillo JC, Garcia-Velasco J, Humaidan P**, Empty follicle syndrome after GnRHa triggering versus hCG triggering in COS, *J Assist Reprod Genet* 29:249, 2012.
523. **Kasapoglu I, Turk P, Dayan A, Uncu G**, Does the presence of endometriosis cause a challenge for transvaginal oocyte retrieval procedure? A comparison between patients with endometriosis and without endometriosis, *J Turk Ger Gynecol Assoc* 19:151, 2018.
524. **Tureck RW, Garcia CR, Blasco L, Mastroianni L Jr**, Perioperative complications arising after transvaginal oocyte retrieval, *Obstet Gynecol* 81:590, 1993.
525. **Yaron Y, Peyser MR, Samuel D, Amit A, Lessing JB**, Infected endometriotic cysts secondary to oocyte aspiration for in-vitro fertilization, *Hum Reprod* 9:1759, 1994.
526. **Levi-Setti PE, Cirillo F, Scolaro V, Morengi E, Heilbron F, Girardello D, Zannoni E, Patrizio P**, Appraisal of clinical complications after 23,827 oocyte retrievals in a large assisted reproductive technology program, *Fertil Steril* 109:1038.e1, 2018.
527. **Coccia ME, Becattini C, Bracco GL, Scarselli G**, Acute abdomen following dermoid cyst rupture during transvaginal ultrasonographically guided retrieval of oocytes, *Hum Reprod* 11:1897, 1996.
528. **Azem F, Wolf Y, Botchan A, Amit A, Lessing JB, Kluger Y**, Massive retroperitoneal bleeding: a complication of transvaginal ultrasonography-guided oocyte retrieval for in vitro fertilization-embryo transfer, *Fertil Steril* 74:405, 2000.
529. **Almog B, Rimon E, Yovel I, Bar-Am A, Amit A, Azem F**, Vertebral osteomyelitis: a rare complication of transvaginal ultrasound-guided oocyte retrieval, *Fertil Steril* 73:1250, 2000.
530. **El-Shawarby S, Margara R, Trew G, Lavery S**, A review of complications following transvaginal oocyte retrieval for in-vitro fertilization, *Hum Fertil (Camb)* 7:127, 2004.

531. **Mehri S, Levi Setti PE, Greco K, Sakkas D, Martinez G, Patrizio P**, Correlation between follicular diameters and flushing versus no flushing on oocyte maturity, fertilization rate and embryo quality, *J Assist Reprod Genet* 31:73, 2014.
532. **Rosen MP, Shen S, Dobson AT, Rinaudo PF, McCulloch CE, Cedars MI**, A quantitative assessment of follicle size on oocyte developmental competence, *Fertil Steril* 90:684, 2008.
533. **Gilchrist RB, Nayudu PL, Nowshari MA, Hodges JK**, Meiotic competence of marmoset monkey oocytes is related to follicle size and oocyte-somatic cell associations, *Biol Reprod* 52:1234, 1995.
534. **Veeck LL**, Oocyte assessment and biological performance, *Ann N Y Acad Sci* 541:259, 1988.
535. **Lin YC, Chang SY, Lan KC, Huang HW, Chang CY, Tsai MY, Kung FT, Huang FJ**, Human oocyte maturity in vivo determines the outcome of blastocyst development in vitro, *J Assist Reprod Genet* 20:506, 2003.
536. **Moor RM, Dai Y, Lee C, Fulka J Jr**, Oocyte maturation and embryonic failure, *Hum Reprod Update* 4:223, 1998.
537. **Borghol N, Lornage J, Blachere T, Sophie Garret A, Lefevre A**, Epigenetic status of the H19 locus in human oocytes following in vitro maturation, *Genomics* 87:417, 2006.
538. **Bromfield J, Messamore W, Albertini DF**, Epigenetic regulation during mammalian oogenesis, *Reprod Fertil Dev* 20:74, 2008.
539. **Dahan MH, Tan SL, Chung J, Son WY**, Clinical definition paper on in vitro maturation of human oocytes, *Hum Reprod* 31:1383, 2016.
540. **Cha KY, Koo JJ, Ko JJ, Choi DH, Han SY, Yoon TK**, Pregnancy after in vitro fertilization of human follicular oocytes collected from nonstimulated cycles, their culture in vitro and their transfer in a donor oocyte program, *Fertil Steril* 55:109, 1991.
541. **Baker SJ, Spears N**, The role of intra-ovarian interactions in the regulation of follicle dominance, *Hum Reprod Update* 5:153, 1999.
542. **Trounson A, Anderiesz C, Jones G**, Maturation of human oocytes in vitro and their developmental competence, *Reproduction* 121:51, 2001.
543. **Child TJ, Abdul-Jalil AK, Gulekli B, Tan SL**, In vitro maturation and fertilization of oocytes from unstimulated normal ovaries, polycystic ovaries, and women with polycystic ovary syndrome, *Fertil Steril* 76:936, 2001.
544. **Soderstrom-Anttila V, Makinen S, Tuuri T, Suikkari AM**, Favourable pregnancy results with insemination of in vitro matured oocytes from unstimulated patients, *Hum Reprod* 20:1534, 2005.
545. **Mikkelsen AL, Andersson AM, Skakkebaek NE, Lindenberg S**, Basal concentrations of oestradiol may predict the outcome of in-vitro maturation in regularly menstruating women, *Hum Reprod* 16:862, 2001.
546. **Mikkelsen AL, Smith S, Lindenberg S**, Impact of oestradiol and inhibin A concentrations on pregnancy rate in in-vitro oocyte maturation, *Hum Reprod* 15:1685, 2000.
547. **Mikkelsen AL, Smith SD, Lindenberg S**, In-vitro maturation of human oocytes from regularly menstruating women may be successful without follicle stimulating hormone priming, *Hum Reprod* 14:1847, 1999.
548. **Cha KY, Han SY, Chung HM, Choi DH, Lim JM, Lee WS, Ko JJ, Yoon TK**, Pregnancies and deliveries after in vitro maturation culture followed by in vitro fertilization and embryo transfer without stimulation in women with polycystic ovary syndrome, *Fertil Steril* 73:978, 2000.
549. **Siristatidis C, Sergeantanis TN, Vogiatzi P, Kanavidis P, Chrelias C, Papantoniou N, Psaltopoulou T**, In vitro maturation in women with vs. without polycystic ovarian syndrome: a systematic review and meta-analysis, *PLoS One* 10:e0134696, 2015.
550. **Cha KY, Chung HM, Lee DR, Kwon H, Chung MK, Park LS, Choi DH, Yoon TK**, Obstetric outcome of patients with polycystic ovary syndrome treated by in vitro maturation and in vitro fertilization-embryo transfer, *Fertil Steril* 83: 1461, 2005.
551. **Chian RC, Buckett WM, Tulandi T, Tan SL**, Prospective randomized study of human chorionic gonadotrophin priming before immature oocyte retrieval from unstimulated women with polycystic ovarian syndrome, *Hum Reprod* 15:165, 2000.
552. **Child TJ, Phillips SJ, Abdul-Jalil AK, Gulekli B, Tan SL**, A comparison of in vitro maturation and in vitro



fertilization for women with polycystic ovaries, *Obstet Gynecol* 100:665, 2002.

553. **Le Du A, Kadoch IJ, Bourcigaux N, Doumerc S, Bourrier MC, Chevalier N, Fanchin R, Chian RC, Tachdjian G, Frydman R, Frydman N**, In vitro oocyte maturation for the treatment of infertility associated with polycystic ovarian syndrome: the French experience, *Hum Reprod* 20:420, 2005.
554. **Lin YH, Hwang JL, Huang LW, Mu SC, Seow KM, Chung J, Hsieh BC, Huang SC, Chen CY, Chen PH**, Combination of FSH priming and hCG priming for in-vitro maturation of human oocytes, *Hum Reprod* 18:1632, 2003.
555. **Mikkelsen AL, Lindenberg S**, Benefit of FSH priming of women with PCOS to the in vitro maturation procedure and the outcome: a randomized prospective study, *Reproduction* 122:587, 2001.
556. **Fadini R, Dal Canto MB, Mignini Renzini M, Brambillasca F, Comi R, Fumagalli D, Lain M, Merola M, Milani R, De Ponti E**, Effect of different gonadotrophin priming on IVM of oocytes from women with normal ovaries: a prospective randomized study, *Reprod Biomed Online* 19:343, 2009.
557. **Reavey J, Vincent K, Child T, Granne IE**, Human chorionic gonadotrophin priming for fertility treatment with in vitro maturation, *Cochrane Database Syst Rev* (11):CD008720, 2016.
558. **Yoon HG, Yoon SH, Son WY, Lee SW, Park SP, Im KS, Lim JH**, Pregnancies resulting from in vitro matured oocytes collected from women with regular menstrual cycle, *J Assist Reprod Genet* 18:325, 2001.
559. **Cobo AC, Requena A, Neuspiller F, Aragon s M, Mercader A, Navarro J, Simon C, Remohi J, Pellicer A**, Maturation in vitro of human oocytes from unstimulated cycles: selection of the optimal day for ovum retrieval based on follicular size, *Hum Reprod* 14:1864, 1999.
560. **Jurema MW, Nogueira D**, In vitro maturation of human oocytes for assisted reproduction, *Fertil Steril* 86:1277, 2006.
561. **Wynn P, Picton HM, Krapez JA, Rutherford AJ, Balen AH, Gosden RG**, Pretreatment with follicle stimulating hormone promotes the numbers of human oocytes reaching metaphase II by in-vitro maturation, *Hum Reprod* 13:3132, 1998.
562. **Hashimoto S, Fukuda A, Murata Y, Kikkawa M, Oku H, Kanaya H, Sonoda M, Sugihara K, Murata T, Nagata F, Nakaoaka Y, Morimoto Y**, Effect of aspiration vacuum on the developmental competence of immature human oocytes retrieved using a 20-gauge needle, *Reprod Biomed Online* 14:444, 2007.
563. **Walls M, Junk S, Ryan JP, Hart R**, IVF versus ICSI for the fertilization of in-vitro matured human oocytes, *Reprod Biomed Online* 25:603, 2012.
564. **Centers for Disease Control and Prevention**, 2015 Assisted Reproductive Technology Success Rates. National Summary and Fertility Clinic Reports, Centers for Disease Control and Prevention, Atlanta, 2017.
565. **Zhang XY, Ata B, Son WY, Buckett WM, Tan SL, Ao A**, Chromosome abnormality rates in human embryos obtained from in-vitro maturation and IVF treatment cycles, *Reprod Biomed Online* 21:552, 2010.
566. **Spits C, Guzman L, Mertzaniidou A, Jacobs K, Ortega-Hrepich C, Gilchrist RB, Thompson JG, De Vos M, Smitz J, Sermon K**, Chromosome constitution of human embryos generated after in vitro maturation including 3-isobutyl-1-methylxanthine in the oocyte collection medium, *Hum Reprod* 30:653, 2015.
567. **Walls ML, Hunter T, Ryan JP, Keelan JA, Nathan E, Hart RJ**, In vitro maturation as an alternative to standard in vitro fertilization for patients diagnosed with polycystic ovaries: a comparative analysis of fresh, frozen and cumulative cycle outcomes, *Hum Reprod* 30:88, 2015.
568. **Chian RC, Xu CL, Huang JY, Ata B**, Obstetric outcomes and congenital abnormalities in infants conceived with oocytes matured in vitro, *Facts Views Vis Obgyn* 6:15, 2014.
569. **Son WY, Tan SL**, Laboratory and embryological aspects of hCG-primed in vitro maturation cycles for patients with polycystic ovaries, *Hum Reprod Update* 16:675, 2010.
570. **Prakash P, Leykin L, Chen Z, Toth T, Sayegh R, Schiff I, Isaacson K**, Preparation by differential gradient centrifugation is better than swim-up in selecting sperm with normal morphology (strict criteria), *Fertil Steril* 69:722, 1998.
571. **Lim CC, Lewis SE, Kennedy M, Donnelly ET, Thompson W**, Human sperm morphology and in vitro fertilization: sperm tail defects are prognostic for fertilization failure, *Andrologia* 30:43, 1998.
572. **Sapienza F, Verheyen G, Tournaye H, Janssens R, Pletinckx I, Derde M, Van Steirteghem A**, An auto-controlled study in in-vitro fertilization reveals the benefit of Percoll centrifugation to swim-up in the preparation

of poor-quality semen, *Hum Reprod* 8:1856, 1993.

573. **Van der Zwahlen P, Bertin-Segal G, Geerts L, Debauche C, Schoysman R**, Sperm morphology and IVF pregnancy rate: comparison between Percoll gradient centrifugation and swim-up procedures, *Hum Reprod* 6:581, 1991.
574. **Yamanaka M, Tomita K, Hashimoto S, Matsumoto H, Satoh M, Kato H, Hosoi Y, Inoue M, Nakaoka Y, Morimoto Y**, Combination of density gradient centrifugation and swim-up methods effectively decreases morphologically abnormal sperms, *J Reprod Dev* 62:599, 2016.
575. **Quinn MM, Jalalian L, Ribeiro S, Ona K, Demirci U, Cedars MI, Rosen MP**, Microfluidic sorting selects sperm for clinical use with reduced DNA damage compared to density gradient centrifugation with swim-up in split semen samples, *Hum Reprod*, 2018 Jul 10. doi: 10.1093/humrep/dey239.
576. **Shirota K, Yotsumoto F, Itoh H, Obama H, Hidaka N, Nakajima K, Miyamoto S**, Separation efficiency of a microfluidic sperm sorter to minimize sperm DNA damage, *Fertil Steril* 105:315.e1, 2016.
577. **Rappa KL, Rodriguez HF, Hakkarainen GC, Anchan RM, Mutter GL, Asghar W**, Sperm processing for advanced reproductive technologies: where are we today? *Biotechnol Adv* 34:578, 2016.
578. **Van Blerkom J, Henry G, Porreco R**, Preimplantation human embryonic development from polypronuclear eggs after in vitro fertilization, *Fertil Steril* 41:686, 1984.
579. **van der Ven HH, Al-Hasani S, Diedrich K, Hamerich U, Lehmann F, Krebs D**, Polyspermy in in vitro fertilization of human oocytes: frequency and possible causes, *Ann N Y Acad Sci* 442:88, 1985.
580. **McFadden DE, Langlois S**, Parental and meiotic origin of triploidy in the embryonic and fetal periods, *Clin Genet* 58:192, 2000.
581. **McFadden DE, Pantzar JT**, Placental pathology of triploidy, *Hum Pathol* 27:1018, 1996.
582. **Society for Assisted Reproductive Technology; American Society for Reproductive Medicine**, Assisted reproductive technology in the United States: 2001 results generated from the American Society for Reproductive Medicine/Society for Assisted Reproductive Technology registry, *Fertil Steril* 87: 1253, 2007.
583. **Bhattacharya S, Hamilton MP, Shaaban M, Khalaf Y, Seddler M, Ghobara T, Braude P, Kennedy R, Rutherford A, Hartshorne G, Templeton A**, Conventional in-vitro fertilisation versus intracytoplasmic sperm injection for the treatment of non-male-factor infertility: a randomised controlled trial, *Lancet* 357:2075, 2001.
584. **van Rumste MM, Evers JL, Farquhar CM**, Intra-cytoplasmic sperm injection versus conventional techniques for oocyte insemination during in vitro fertilisation in patients with non-male subfertility, *Cochrane Database Syst Rev* (2):CD001301, 2003.
585. **Jow WW, Steckel J, Schlegel PN, Magid MS, Goldstein M**, Motile sperm in human testis biopsy specimens, *J Androl* 14:194, 1993.
586. **Silber SJ, Nagy Z, Devroey P, Tournaye H, Van Steirteghem AC**, Distribution of spermatogenesis in the testicles of azoospermic men: the presence or absence of spermatids in the testes of men with germinal failure, *Hum Reprod* 12:2422, 1997.
587. **Practice Committee of American Society for Reproductive Medicine; Practice Committee of Society for Assisted Reproductive Technology**, Round spermatid nucleus injection (ROSNI), *Fertil Steril* 90:S199, 2008.
588. **Anguiano A, Oates RD, Amos JA, Dean M, Gerrard B, Stewart C, Maher TA, White MB, Milunsky A**, Congenital bilateral absence of the vas deferens. A primarily genital form of cystic fibrosis, *JAMA* 267:1794, 1992.
589. **Oates RD, Amos JA**, The genetic basis of congenital bilateral absence of the vas deferens and cystic fibrosis, *J Androl* 15:1, 1994.
590. **Male Infertility Best Practice Policy Committee of the American Urological Association; Practice Committee of the American Society for Reproductive Medicine**, Report on optimal evaluation of the infertile male, *Fertil Steril* 86:S202, 2006.
591. **Hershlag A, Schiff SF, DeCherney AH**, Retrograde ejaculation, *Hum Reprod* 6:255, 1991.
592. **Yavetz H, Yogev L, Hauser R, Lessing JB, Paz G, Homonnai ZT**, Retrograde ejaculation, *Hum Reprod* 9:381, 1994.

593. **Gerig NE, Meacham RB, Ohl DA**, Use of electroejaculation in the treatment of ejaculatory failure secondary to diabetes mellitus, *Urology* 49:239, 1997.
594. **Ohl DA, Sonksen J, Menge AC, McCabe M, Keller LM**, Electroejaculation versus vibratory stimulation in spinal cord injured men: sperm quality and patient preference, *J Urol* 157:2147, 1997.
595. **Matthews GJ, Goldstein M**, A simplified method of epididymal sperm aspiration, *Urology* 47:123, 1996.
596. **Nudell DM, Conaghan J, Pedersen RA, Givens CR, Schriock ED, Turek PJ**, The mini-micro-epididymal sperm aspiration for sperm retrieval: a study of urological outcomes, *Hum Reprod* 13:1260, 1998.
597. **Janzen N, Goldstein M, Schlegel PN, Palermo GD, Rosenwaks Z, Hariprashad J**, Use of electively cryopreserved microsurgically aspirated epididymal sperm with IVF and intracytoplasmic sperm injection for obstructive azoospermia, *Fertil Steril* 74:696, 2000.
598. **Shrivastav P, Nadkarni P, Wensvoort S, Craft I**, Percutaneous epididymal sperm aspiration for obstructive azoospermia, *Hum Reprod* 9:2058, 1994.
599. **Craft IL, Khalifa Y, Boulos A, Pelekanos M, Foster C, Tsirigotis M**, Factors influencing the outcome of in-vitro fertilization with percutaneous aspirated epididymal spermatozoa and intracytoplasmic sperm injection in azoospermic men, *Hum Reprod* 10:1791, 1995.
600. **Craft I, Tsirigotis M**, Simplified recovery, preparation and cryopreservation of testicular spermatozoa, *Hum Reprod* 10:1623, 1995.
601. **Friedler S, Raziell A, Strassburger D, Soffer Y, Komarovsky D, Ron-El R**, Testicular sperm retrieval by percutaneous fine needle sperm aspiration compared with testicular sperm extraction by open biopsy in men with non-obstructive azoospermia, *Hum Reprod* 12:1488, 1997.
602. **Schlegel PN**, Testicular sperm extraction: microdissection improves sperm yield with minimal tissue excision, *Hum Reprod* 14:131, 1999.
603. **Dardashti K, Williams RH, Goldstein M**, Microsurgical testis biopsy: a novel technique for retrieval of testicular tissue, *J Urol* 163:1206, 2000.
604. **Su LM, Palermo GD, Goldstein M, Veeck LL, Rosenwaks Z, Schlegel PN**, Testicular sperm extraction with intracytoplasmic sperm injection for nonobstructive azoospermia: testicular histology can predict success of sperm retrieval, *J Urol* 161:112, 1999.
605. **Chan PT, Palermo GD, Veeck LL, Rosenwaks Z, Schlegel PN**, Testicular sperm extraction combined with intracytoplasmic sperm injection in the treatment of men with persistent azoospermia postchemotherapy, *Cancer* 92:1632, 2001.
606. **Palermo GD, Schlegel PN, Sills ES, Veeck LL, Zaninovic N, Menendez S, Rosenwaks Z**, Births after intracytoplasmic injection of sperm obtained by testicular extraction from men with nonmosaic Klinefelter's syndrome, *N Engl J Med* 338:588, 1998.
607. **Ron-El R, Strassburger D, Friedler S, Komarovski D, Bern O, Soffer Y, Raziell A**, Extended sperm preparation: an alternative to testicular sperm extraction in non-obstructive azoospermia, *Hum Reprod* 12:1222, 1997.
608. **Schlegel PN, Su LM**, Physiological consequences of testicular sperm extraction, *Hum Reprod* 12:1688, 1997.
609. **Ostad M, Liotta D, Ye Z, Schlegel PN**, Testicular sperm extraction for nonobstructive azoospermia: results of a multibiopsy approach with optimized tissue dispersion, *Urology* 52:692, 1998.
610. **Friedler S, Raziell A, Schachter M, Strassburger D, Bern O, Ron-El R**, Outcome of first and repeated testicular sperm extraction and ICSI in patients with non-obstructive azoospermia, *Hum Reprod* 17:2356, 2002.
611. **Podsiadly BT, Woolcott RJ, Stanger JD, Stevenson K**, Pregnancy resulting from intracytoplasmic injection of cryopreserved spermatozoa recovered from testicular biopsy, *Hum Reprod* 11:1306, 1996.
612. **Gil-Salom M, Romero J, Minguez Y, Rubio C, De los Santos MJ, Remohi J, Pellicer A**, Pregnancies after intracytoplasmic sperm injection with cryopreserved testicular spermatozoa, *Hum Reprod* 11:1309, 1996.
613. **Friedler S, Raziell A, Strassburger D, Schachter M, Soffer Y, Ron-El R**, Factors influencing the outcome of ICSI in patients with obstructive and non-obstructive azoospermia: a comparative study, *Hum Reprod* 17:3114, 2002.
614. **Levrant D, Bider D, Yonesh M, Yemini Z, Seidman DS, Mashiach S, Dor J**, A randomized study of intracytoplasmic sperm injection (ICSI) versus subzonal insemination (SUZI) for the management of severe

male-factor infertility, *J Assist Reprod Genet* 12:319, 1995.

615. **Tarlatzis BC, Bili H**, Intracytoplasmic sperm injection. Survey of world results, *Ann N Y Acad Sci* 900:336, 2000.
616. **Gordon JW, Grunfeld L, Garrisi GJ, Talansky BE, Richards C, Laufer N**, Fertilization of human oocytes by sperm from infertile males after zona pellucida drilling, *Fertil Steril* 50:68, 1988.
617. **Strohmer H, Feichtinger W**, Successful clinical application of laser for micromanipulation in an in vitro fertilization program, *Fertil Steril* 58:212, 1992.
618. **Malter HE, Cohen J**, Partial zona dissection of the human oocyte: a nontraumatic method using micromanipulation to assist zona pellucida penetration, *Fertil Steril* 51:139, 1989.
619. **Fishel S, Antinori S, Jackson P, Johnson J, Rinaldi L**, Presentation of six pregnancies established by sub-zonal insemination (SUZI), *Hum Reprod* 6:124, 1991.
620. **Palermo G, Joris H, Devroey P, Van Steirteghem AC**, Pregnancies after intracytoplasmic injection of single spermatozoon into an oocyte, *Lancet* 340:17, 1992.
621. **Tesarik J, Sousa M, Testart J**, Human oocyte activation after intracytoplasmic sperm injection, *Hum Reprod* 9:511, 1994.
622. **Tesarik J, Sousa M**, Key elements of a highly efficient intracytoplasmic sperm injection technique: Ca<sup>2+</sup> fluxes and oocyte cytoplasmic dislocation, *Fertil Steril* 64:770, 1995.
623. **Gearon CM, Taylor AS, Forman RG**, Factors affecting activation and fertilization of human oocytes following intracytoplasmic injection, *Hum Reprod* 10:896, 1995.
624. **Gerris J, Mangelschots K, Van Royen E, Joostens M, Eestermans W, Ryckaert G**, ICSI and severe male-factor infertility: breaking the sperm tail prior to injection, *Hum Reprod* 10:484, 1995.
625. **Dozortsev D, Rybouchkin A, De Sutter P, Dhont M**, Sperm plasma membrane damage prior to intracytoplasmic sperm injection: a necessary condition for sperm nucleus decondensation, *Hum Reprod* 10:2960, 1995.
626. **Hewitson L, Dominko T, Takahashi D, Martinovich C, Ramalho-Santos J, Sutovsky P, Fanton J, Jacob D, Monteith D, Neuringer M, Battaglia D, Simerly C, Schatten G**, Unique checkpoints during the first cell cycle of fertilization after intracytoplasmic sperm injection in rhesus monkeys, *Nat Med* 5:431, 1999.
627. **Hardarson T, Lundin K, Hamberger L**, The position of the metaphase II spindle cannot be predicted by the location of the first polar body in the human oocyte, *Hum Reprod* 15:1372, 2000.
628. **Wang WH, Meng L, Hackett RJ, Odenbourg R, Keefe DL**, The spindle observation and its relationship with fertilization after intracytoplasmic sperm injection in living human oocytes, *Fertil Steril* 75:348, 2001.
629. **Hershlag A, Paine T, Kvapil G, Feng H, Napolitano B**, In vitro fertilization-intracytoplasmic sperm injection split: an insemination method to prevent fertilization failure, *Fertil Steril* 77:229, 2002.
630. **Jaroudi K, Al-Hassan S, Al-Sufayan H, Al-Mayman H, Qeba M, Coskun S**, Intracytoplasmic sperm injection and conventional in vitro fertilization are complementary techniques in management of unexplained infertility, *J Assist Reprod Genet* 20:377, 2003.
631. **Barnes FL, Crombie A, Gardner DK, Kausche A, Lacham-Kaplan O, Suikkari AM, Tiglias J, Wood C, Trounson AO**, Blastocyst development and birth after in-vitro maturation of human primary oocytes, intracytoplasmic sperm injection and assisted hatching, *Hum Reprod* 10:3243, 1995.
632. **Nagy ZP, Cecile J, Liu J, Loccufer A, Devroey P, Van Steirteghem A**, Pregnancy and birth after intracytoplasmic sperm injection of in vitro matured germinal-vesicle stage oocytes: case report, *Fertil Steril* 65:1047, 1996.
633. **Chian RC, Gulekli B, Buckett WM, Tan SL**, Priming with human chorionic gonadotropin before retrieval of immature oocytes in women with infertility due to the polycystic ovary syndrome, *N Engl J Med* 341:1624, 1626, 1999.
634. **Tucker MJ, Wright G, Morton PC, Massey JB**, Birth after cryopreservation of immature oocytes with subsequent in vitro maturation, *Fertil Steril* 70:578, 1998.
635. **Kuleshova L, Gianaroli L, Magli C, Ferraretti A, Trounson A**, Birth following vitrification of a small number of human oocytes: case report, *Hum Reprod* 14:3077, 1999.
636. **Schroeder AC, Schultz RM, Kopf GS, Taylor FR, Becker RB, Eppig JJ**, Fetuin inhibits zona pellucida

- hardening and conversion of ZP2 to ZP2f during spontaneous mouse oocyte maturation in vitro in the absence of serum, *Biol Reprod* 43:891, 1990.
637. **Zhang X, Rutledge J, Armstrong DT**, Studies on zona hardening in rat oocytes that are matured in vitro in a serum-free medium, *Mol Reprod Dev* 28:292, 1991.
638. **Vincent C, Pickering SJ, Johnson MH**, The hardening effect of dimethylsulphoxide on the mouse zona pellucida requires the presence of an oocyte and is associated with a reduction in the number of cortical granules present, *J Reprod Fertil* 89:253, 1990.
639. **Manna C, Rienzi L, Greco E, Sbracia M, Rahman A, Poverini R, Siracusa G, De Felici M**, Zona pellucida solubility and cortical granule complements in human oocytes following assisted reproductive techniques, *Zygote* 9:201, 2001.
640. **Mahadevan MM**, Optimization of culture conditions for human in vitro fertilization and embryo transfer, *Semin Reprod Endocrinol* 16:197, 1998.
641. **Gardner DK, Lane M**, Embryo culture, In: Gardner DK, Weissman A, Howles CM, Shoham Z, eds. *Textbook of Assisted Reproductive Techniques: Laboratory and Clinical Perspectives*, Martin Dunitz, London, 2001.
642. **Boiso I, Veiga A, Edwards RG**, Fundamentals of human embryonic growth in vitro and the selection of high-quality embryos for transfer, *Reprod Biomed Online* 5:328, 2002.
643. **Gardner DK, Pool TB, Lane M**, Embryo nutrition and energy metabolism and its relationship to embryo growth, differentiation, and viability, *Semin Reprod Med* 18:205, 2000.
644. **Gardner DK, Lane M, Calderon I, Leeton J**, Environment of the preimplantation human embryo in vivo: metabolite analysis of oviduct and uterine fluids and metabolism of cumulus cells, *Fertil Steril* 65:349, 1996.
645. **Gardner DK**, Changes in requirements and utilization of nutrients during mammalian preimplantation embryo development and their significance in embryo culture, *Theriogenology* 49:83, 1998.
646. **Sfountouris IA, Martins WP, Nastri CO, Viana IG, Navarro PA, Raine-Fenning N, van der Poel S, Rienzi L, Racowsky C**, Blastocyst culture using single versus sequential media in clinical IVF: a systematic review and meta-analysis of randomized controlled trials, *J Assist Reprod Genet* 33:1261, 2016.
647. **Hardarson T, Bungum M, Conaghan J, Meintjes M, Chantilis SJ, Molnar L, Gunnarsson K, Wikland M**, Noninferiority, randomized, controlled trial comparing embryo development using media developed for sequential or undisturbed culture in a time-lapse setup, *Fertil Steril* 104:1452.e1, 2015.
648. **Costa-Borges N, Belles M, Meseguer M, Galliano D, Ballesteros A, Calderon G**, Blastocyst development in single medium with or without renewal on day 3: a prospective cohort study on sibling donor oocytes in a time-lapse incubator, *Fertil Steril* 105:707, 2016.
649. **Cimadomo D, Scarica C, Maggiulli R, Orlando G, Soscia D, Albricci L, Romano S, Sanges F, Ubaldi FM, Rienzi L**, Continuous embryo culture elicits higher blastulation but similar cumulative delivery rates than sequential: a large prospective study, *J Assist Reprod Genet* 35:1329, 2018.
650. **Werner MD, Hong KH, Franasiak JM, Forman EJ, Reda CV, Molinaro TA, Upham KM, Scott RT Jr**, Sequential versus Monophasic Media Impact Trial (SuMMIT): a paired randomized controlled trial comparing a sequential media system to a monophasic medium, *Fertil Steril* 105:1215, 2016.
651. **Braude P, Bolton V, Moore S**, Human gene expression first occurs between the four- and eight-cell stages of preimplantation development, *Nature* 332:459, 1988.
652. **Taylor DM, Ray PF, Ao A, Winston RM, Handyside AH**, Paternal transcripts for glucose-6-phosphate dehydrogenase and adenosine deaminase are first detectable in the human preimplantation embryo at the three- to four-cell stage, *Mol Reprod Dev* 48:442, 1997.
653. **Janny L, Menezo YJ**, Evidence for a strong paternal effect on human preimplantation embryo development and blastocyst formation, *Mol Reprod Dev* 38:36, 1994.
654. **Miller JE, Smith TT**, The effect of intracytoplasmic sperm injection and semen parameters on blastocyst development in vitro, *Hum Reprod* 16:918, 2001.
655. **Edwards LJ, Williams DA, Gardner DK**, Intracellular pH of the mouse preimplantation embryo: amino acids act as buffers of intracellular pH, *Hum Reprod* 13:3441, 1998.
656. **Lane M**, Mechanisms for managing cellular and homeostatic stress in vitro, *Theriogenology* 55:225, 2001.

657. **Hammer MA, Kolajova M, Leveille M, Claman P, Baltz JM**, Glycine transport by single human and mouse embryos, *Hum Reprod* 15:419, 2000.
658. **Lane M, Gardner DK**, Amino acids and vitamins prevent culture-induced metabolic perturbations and associated loss of viability of mouse blastocysts, *Hum Reprod* 13:991, 1998.
659. **Pellicer A, Valbuena D, Cano F, Remohi J, Simon C**, Lower implantation rates in high responders: evidence for an altered endocrine milieu during the preimplantation period, *Fertil Steril* 65:1190, 1996.
660. **Simon C, Garcia Velasco JJ, Valbuena D, Peinado JA, Moreno C, Remohi J, Pellicer A**, Increasing uterine receptivity by decreasing estradiol levels during the preimplantation period in high responders with the use of a follicle-stimulating hormone step-down regimen, *Fertil Steril* 70:234, 1998.
661. **Fanchin R, Righini C, Olivennes F, Taylor S, de Ziegler D, Frydman R**, Uterine contractions at the time of embryo transfer alter pregnancy rates after in-vitro fertilization, *Hum Reprod* 13:1968, 1998.
662. **Fanchin R, Ayoubi JM, Righini C, Olivennes F, Schonauer LM, Frydman R**, Uterine contractility decreases at the time of blastocyst transfers, *Hum Reprod* 16:1115, 2001.
663. **Gardner DK, Lane M**, Culture of viable human blastocysts in defined sequential serum-free media, *Hum Reprod* 13(Suppl 3):148; discussion 160, 1998.
664. **Wilson M, Hartke K, Kiehl M, Rodgers J, Brabec C, Lyles R**, Integration of blastocyst transfer for all patients, *Fertil Steril* 77:693, 2002.
665. **Patton PE, Sadler-Fredd K, Burry KA, Gorrill MJ, Johnson A, Larson JM, Wolf DP**, Development and integration of an extended embryo culture program, *Fertil Steril* 72:418, 1999.
666. **Langley MT, Marek DM, Gardner DK, Doody KM, Doody KJ**, Extended embryo culture in human assisted reproduction treatments, *Hum Reprod* 16:902, 2001.
667. **Schoolcraft WB, Gardner DK**, Blastocyst culture and transfer increases the efficiency of oocyte donation, *Fertil Steril* 74:482, 2000.
668. **Glujovsky D, Farquhar C, Quinteiro Retamar AM, Alvarez Sedo CR, Blake D**, Cleavage stage versus blastocyst stage embryo transfer in assisted reproductive technology, *Cochrane Database Syst Rev* (6):CD002118, 2016.
669. **Yang L, Cai S, Zhang S, Kong X, Gu Y, Lu C, Dai J, Gong F, Lu G, Lin G**, Single embryo transfer by Day 3 time-lapse selection versus Day 5 conventional morphological selection: a randomized, open-label, non-inferiority trial, *Hum Reprod* 33:869, 2018.
670. **Seli E, Robert C, Sirard MA**, OMICS in assisted reproduction: possibilities and pitfalls, *Mol Hum Reprod* 16:513, 2010.
671. **Schoolcraft WB, Fragouli E, Stevens J, Munne S, Katz-Jaffe MG, Wells D**, Clinical application of comprehensive chromosomal screening at the blastocyst stage, *Fertil Steril* 94:1700, 2010.
672. **Thomas MR, Sparks AE, Ryan GL, Van Voorhis BJ**, Clinical predictors of human blastocyst formation and pregnancy after extended embryo culture and transfer, *Fertil Steril* 94:543, 2010.
673. **Dessolle L, Freour T, Barriere P, Darai E, Ravel C, Jean M, Coutant C**, A cycle-based model to predict blastocyst transfer cancellation, *Hum Reprod* 25:598, 2010.
674. **Racowsky C, Jackson KV, Cekleniak NA, Fox JH, Hornstein MD, Ginsburg ES**, The number of eight-cell embryos is a key determinant for selecting day 3 or day 5 transfer, *Fertil Steril* 73:558, 2000.
675. **Neuber E, Rinaudo P, Trimarchi JR, Sakkas D**, Sequential assessment of individually cultured human embryos as an indicator of subsequent good quality blastocyst development, *Hum Reprod* 18:1307, 2003.
676. **Shoukir Y, Chardonnes D, Campana A, Bischof P, Sakkas D**, The rate of development and time of transfer play different roles in influencing the viability of human blastocysts, *Hum Reprod* 13:676, 1998.
677. **Gardner DK, Schoolcraft WB, Wagley L, Schlenker T, Stevens J, Hesla J**, A prospective randomized trial of blastocyst culture and transfer in in-vitro fertilization, *Hum Reprod* 13:3434, 1998.
678. **Armstrong S, Bhide P, Jordan V, Pacey A, Farquhar C**, Time-lapse systems for embryo incubation and assessment in assisted reproduction, *Cochrane Database Syst Rev* (5):CD011320, 2018.
679. **Goto K, Kumasako Y, Koike M, Kanda A, Kido K, Nagaki M, Otsu E, Kawabe F, Kai Y, Utsunomiya T**, Prediction of the in vitro developmental competence of early-cleavage-stage human embryos with time-lapse imaging and oxygen consumption rate measurement, *Reprod Med Biol* 17:289, 2018.

680. **Kirkegaard K, Kesmodel US, Hindkjaer JJ, Ingerslev HJ**, Time-lapse parameters as predictors of blastocyst development and pregnancy outcome in embryos from good prognosis patients: a prospective cohort study, *Hum Reprod* 28:2643, 2013.
681. **Milewski R, Kuc P, Kuczynska A, Stankiewicz B, Lukaszuk K, Kuczynski W**, A predictive model for blastocyst formation based on morphokinetic parameters in time-lapse monitoring of embryo development, *J Assist Reprod Genet* 32:571, 2015.
682. **Motato Y, de los Santos MJ, Escriba MJ, Ruiz BA, Remohi J, Meseguer M**, Morphokinetic analysis and embryonic prediction for blastocyst formation through an integrated time-lapse system, *Fertil Steril* 105:376.e9, 2016.
683. **Desai N, Goldberg JM, Austin C, Falcone T**, Are cleavage anomalies, multinucleation, or specific cell cycle kinetics observed with time-lapse imaging predictive of embryo developmental capacity or ploidy? *Fertil Steril* 109: 665, 2018.
684. **Reignier A, Lammers J, Barriere P, Freour T**, Can time-lapse parameters predict embryo ploidy? A systematic review, *Reprod Biomed Online* 36:380, 2018.
685. **Stillman RJ, Richter KS, Banks NK, Graham JR**, Elective single embryo transfer: a 6-year progressive implementation of 784 single blastocyst transfers and the influence of payment method on patient choice, *Fertil Steril* 92:1895, 2009.
686. **Mullin CM, Fino ME, Talebian S, Krey LC, Licciardi F, Grifo JA**, Comparison of pregnancy outcomes in elective single blastocyst transfer versus double blastocyst transfer stratified by age, *Fertil Steril* 93:1837, 2010.
687. **Gardner DK, Lane M, Stevens J, Schlenker T, Schoolcraft WB**, Blastocyst score affects implantation and pregnancy outcome: towards a single blastocyst transfer, *Fertil Steril* 73:1155, 2000.
688. **Damario MA, Phy JL, Tummon IS**, Successful elective single blastocyst transfer in a patient with prior repetitive high-order multiple gestations, *J Assist Reprod Genet* 19:205, 2002.
689. **Gardner DK, Surrey E, Minjarez D, Leitz A, Stevens J, Schoolcraft WB**, Single blastocyst transfer: a prospective randomized trial, *Fertil Steril* 81:551, 2004.
690. **Vitthala S, Gelbaya TA, Brison DR, Fitzgerald CT, Nardo LG**, The risk of monozygotic twins after assisted reproductive technology: a systematic review and meta-analysis, *Hum Reprod Update* 15:45, 2009.
691. **Chang HJ, Lee JR, Jee BC, Suh CS, Kim SH**, Impact of blastocyst transfer on offspring sex ratio and the monozygotic twinning rate: a systematic review and meta-analysis, *Fertil Steril* 91:2381, 2009.
692. **Papanikolaou EG, Fatemi H, Venetis C, Donoso P, Kolibianakis E, Tournaye H, Tarlatzis B, Devroey P**, Monozygotic twinning is not increased after single blastocyst transfer compared with single cleavage-stage embryo transfer, *Fertil Steril* 93:592, 2010.
693. **Behr B, Fisch JD, Racowsky C, Miller K, Pool TB, Milki AA**, Blastocyst-ET and monozygotic twinning, *J Assist Reprod Genet* 17:349, 2000.
694. **da Costa AA, Abdelmassih S, de Oliveira FG, Abdelmassih V, Abdelmassih R, Nagy ZP, Balmaceda JP**, Monozygotic twins and transfer at the blastocyst stage after ICSI, *Hum Reprod* 16:333, 2001.
695. **Tarlatzis BC, Qublan HS, Sanopoulou T, Zepiridis L, Grimbizis G, Bontis J**, Increase in the monozygotic twinning rate after intracytoplasmic sperm injection and blastocyst stage embryo transfer, *Fertil Steril* 77:196, 2002.
696. **Weston G, Osianlis T, Catt J, Vollenhoven B**, Blastocyst transfer does not cause a sex-ratio imbalance, *Fertil Steril* 92:1302, 2009.
697. **Menezo YJ, Chouteau J, Torello J, Girard A, Veiga A**, Birth weight and sex ratio after transfer at the blastocyst stage in humans, *Fertil Steril* 72:221, 1999.
698. **Milki AA, Jun SH, Hinckley MD, Behr B, Giudice LC, Westphal LM**, Incidence of monozygotic twinning with blastocyst transfer compared to cleavage-stage transfer, *Fertil Steril* 79:503, 2003.
699. **Luna M, Duke M, Copperman A, Grunfeld L, Sandler B, Barritt J**, Blastocyst embryo transfer is associated with a sex-ratio imbalance in favor of male offspring, *Fertil Steril* 87:519, 2007.
700. **Kausche A, Jones GM, Trounson AO, Figueiredo F, MacLachlan V, Lolatgis N**, Sex ratio and birth weights of infants born as a result of blastocyst transfers compared with early cleavage stage embryo transfers, *Fertil Steril* 76:688, 2001.

701. **Alfarawati S, Fragouli E, Colls P, Stevens J, Gutierrez-Mateo C, Schoolcraft WB, Katz-Jaffe MG, Wells D**, The relationship between blastocyst morphology, chromosomal abnormality, and embryo gender, *Fertil Steril* 95:520, 2011.
702. **Mittwoch U**, Blastocysts prepare for the race to be male, *Hum Reprod* 8:1550, 1993.
703. **Alvigi C, Conforti A, Carbone IF, Borrelli R, de Placido G, Guerriero S**, Influence of cryopreservation on perinatal outcome after blastocyst- vs cleavage-stage embryo transfer: systematic review and meta-analysis, *Ultrasound Obstet Gynecol* 51:54, 2018.
704. **Cox GF, Burger J, Lip V, Mau UA, Sperling K, Wu BL, Horsthemke B**, Intracytoplasmic sperm injection may increase the risk of imprinting defects, *Am J Hum Genet* 71:162, 2002.
705. **DeBaun MR, Niemitz EL, Feinberg AP**, Association of in vitro fertilization with Beckwith-Wiedemann syndrome and epigenetic alterations of LIT1 and H19, *Am J Hum Genet* 72:156, 2003.
706. **Gicquel C, Gaston V, Mandelbaum J, Siffroi JP, Flahault A, Le Bouc Y**, In vitro fertilization may increase the risk of Beckwith-Wiedemann syndrome related to the abnormal imprinting of the KCN1OT gene, *Am J Hum Genet* 72:1338, 2003.
707. **Maher ER, Brueton LA, Bowdin SC, Luharia A, Cooper W, Cole TR, Macdonald F, Sampson JR, Barratt CL, Reik W, Hawkins MM**, Beckwith-Wiedemann syndrome and assisted reproduction technology (ART), *J Med Genet* 40:62, 2003.
708. **Moll AC, Imhof SM, Cruysberg JR, Schouten-van Meeteren AY, Boers M, van Leeuwen FE**, Incidence of retinoblastoma in children born after in-vitro fertilisation, *Lancet* 361:309, 2003.
709. **Lidegaard O, Pinborg A, Andersen AN**, Imprinting diseases and IVF: Danish National IVF cohort study, *Hum Reprod* 20:950, 2005.
710. **Santos F, Hyslop L, Stojkovic P, Leary C, Murdoch A, Reik W, Stojkovic M, Herbert M, Dean W**, Evaluation of epigenetic marks in human embryos derived from IVF and ICSI, *Hum Reprod* 25:2387, 2010.
711. **Watkins AJ, Fleming TP**, Blastocyst environment and its influence on offspring cardiovascular health: the heart of the matter, *J Anat* 215:52, 2009.
712. **Amor DJ, Halliday J**, A review of known imprinting syndromes and their association with assisted reproduction technologies, *Hum Reprod* 23:2826, 2008.
713. **Confino E, Rawlins R, Binor Z, Radwanska E**, The effect of the oviduct, uterine, and in vitro environments on zona thinning in the mouse embryo, *Fertil Steril* 68:164, 1997.
714. **Garside WT, Loret de Mola JR, Bucci JA, Tureck RW, Heyner S**, Sequential analysis of zona thickness during in vitro culture of human zygotes: correlation with embryo quality, age, and implantation, *Mol Reprod Dev* 47:99, 1997.
715. **Loret De Mola JR, Garside WT, Bucci J, Tureck RW, Heyner S**, Analysis of the human zona pellucida during culture: correlation with diagnosis and the preovulatory hormonal environment, *J Assist Reprod Genet* 14:332, 1997.
716. **Palmstierna M, Murkes D, Csemiczky G, Andersson O, Wramsby H**, Zona pellucida thickness variation and occurrence of visible mononucleated blastomers in preembryos are associated with a high pregnancy rate in IVF treatment, *J Assist Reprod Genet* 15:70, 1998.
717. **Gabrielsen A, Lindenberg S, Petersen K**, The impact of the zona pellucida thickness variation of human embryos on pregnancy outcome in relation to suboptimal embryo development. A prospective randomized controlled study, *Hum Reprod* 16:2166, 2001.
718. **Keltz MD, Skorupski JC, Bradley K, Stein D**, Predictors of embryo fragmentation and outcome after fragment removal in in vitro fertilization, *Fertil Steril* 86:321, 2006.
719. **Cohen J, Alikani M, Trowbridge J, Rosenwaks Z**, Implantation enhancement by selective assisted hatching using zona drilling of human embryos with poor prognosis, *Hum Reprod* 7:685, 1992.
720. **Lanzendorf SE, Nehchiri F, Mayer JF, Oehninger S, Muasher SJ**, A prospective, randomized, double-blind study for the evaluation of assisted hatching in patients with advanced maternal age, *Hum Reprod* 13:409, 1998.
721. **Hurst BS, Tucker KE, Awoniyi CA, Schlaff WD**, Assisted hatching does not enhance IVF success in good-prognosis patients, *J Assist Reprod Genet* 15:62, 1998.



722. **Magli MC, Gianaroli L, Ferraretti AP, Fortini D, Aicardi G, Montanaro N**, Rescue of implantation potential in embryos with poor prognosis by assisted zona hatching, *Hum Reprod* 13:1331, 1998.
723. **Hellebaut S, De Sutter P, Dozortsev D, Onghena A, Qian C, Dhont M**, Does assisted hatching improve implantation rates after in vitro fertilization or intracytoplasmic sperm injection in all patients? A prospective randomized study, *J Assist Reprod Genet* 13:19, 1996.
724. **Chao KH, Chen SU, Chen HF, Wu MY, Yang YS, Ho HN**, Assisted hatching increases the implantation and pregnancy rate of in vitro fertilization (IVF)-embryo transfer (ET), but not that of IVF-tubal ET in patients with repeated IVF failures, *Fertil Steril* 67:904, 1997.
725. **Obruca A, Strohmer H, Sakkas D, Menezo Y, Kogosowski A, Barak Y, Feichtinger W**, Use of lasers in assisted fertilization and hatching, *Hum Reprod* 9:1723, 1994.
726. **Mantoudis E, Podsiadly BT, Gorgy A, Venkat G, Craft IL**, A comparison between quarter, partial and total laser assisted hatching in selected infertility patients, *Hum Reprod* 16:2182, 2001.
727. **Hsieh YY, Huang CC, Cheng TC, Chang CC, Tsai HD, Lee MS**, Laser-assisted hatching of embryos is better than the chemical method for enhancing the pregnancy rate in women with advanced age, *Fertil Steril* 78:179, 2002.
728. **Fong CY, Bongso A, Ng SC, Kumar J, Trounson A, Ratnam S**, Blastocyst transfer after enzymatic treatment of the zona pellucida: improving in-vitro fertilization and understanding implantation, *Hum Reprod* 13:2926, 1998.
729. **Balaban B, Urman B, Alatas C, Mercan R, Mumcu A, Isiklar A**, A comparison of four different techniques of assisted hatching, *Hum Reprod* 17:1239, 2002.
730. **Nakayama T, Fujiwara H, Yamada S, Tastumi K, Honda T, Fujii S**, Clinical application of a new assisted hatching method using a piezo-micromanipulator for morphologically low-quality embryos in poor-prognosis infertile patients, *Fertil Steril* 71:1014, 1999.
731. **Cohen J, Inge KL, Suzman M, Wiker SR, Wright G**, Videocinematography of fresh and cryopreserved embryos: a retrospective analysis of embryonic morphology and implantation, *Fertil Steril* 51:820, 1989.
732. **Edirisinghe WR, Ahnonkitpanit V, Promviengchai S, Suwajanakorn S, Pruksananonda K, Chinpilas V, Virutamasen P**, A study failing to determine significant benefits from assisted hatching: patients selected for advanced age, zonal thickness of embryos, and previous failed attempts, *J Assist Reprod Genet* 16:294, 1999.
733. **Carney SK, Das S, Blake D, Farquhar C, Seif MM, Nelson L**, Assisted hatching on assisted conception (in vitro fertilisation (IVF) and intracytoplasmic sperm injection (ICSI), *Cochrane Database Syst Rev* (12):CD001894, 2012.
734. **Das S, Blake D, Farquhar C, Seif MM**, Assisted hatching on assisted conception (IVF and ICSI), *Cochrane Database Syst Rev* (2):CD001894, 2009.
735. **Alteri A, Vigano P, Maizar AA, Jovine L, Giacomini E, Rubino P**, Revisiting embryo assisted hatching approaches: a systematic review of the current protocols, *J Assist Reprod Genet* 35:367, 2018.
736. **He F, Zhang CY, Wang LS, Li SL, Hu LN**, Assisted hatching in couples with advanced maternal age: a systematic review and meta-analysis, *Curr Med Sci* 38:552, 2018.
737. **Zeng M, Su S, Li L**, The effect of laser-assisted hatching on pregnancy outcomes of cryopreserved-thawed embryo transfer: a meta-analysis of randomized controlled trials, *Lasers Med Sci* 33:655, 2018.
738. **Li D, Yang DL, An J, Jiao J, Zhou YM, Wu QJ, Wang XX**, Effect of assisted hatching on pregnancy outcomes: a systematic review and meta-analysis of randomized controlled trials, *Sci Rep* 6:31228, 2016.
739. **Hershlag A, Paine T, Cooper GW, Scholl GM, Rawlinson K, Kvapil G**, Monozygotic twinning associated with mechanical assisted hatching, *Fertil Steril* 71:144, 1999.
740. **Schieve LA, Meikle SF, Peterson HB, Jeng G, Burnett NM, Wilcox LS**, Does assisted hatching pose a risk for monozygotic twinning in pregnancies conceived through in vitro fertilization? *Fertil Steril* 74:288, 2000.
741. **Sheen TC, Chen SR, Au HK, Chien YY, Wu KY, Tzeng CR**, Herniated blastomere following chemically assisted hatching may result in monozygotic twins, *Fertil Steril* 75:442, 2001.
742. **Skiadas CC, Missmer SA, Benson CB, Gee RE, Racowsky C**, Risk factors associated with pregnancies containing a monochorionic pair following assisted reproductive technologies, *Hum Reprod* 23:1366, 2008.
743. **Verlinsky Y, Ginsberg N, Lifchez A, Valle J, Moise J, Strom CM**, Analysis of the first polar body:

preconception genetic diagnosis, *Hum Reprod* 5:826, 1990.

744. **Angell RR**, Possible pitfalls in preimplantation diagnosis of chromosomal disorders based on polar body analysis, *Hum Reprod* 9:181, 1994.
745. **Geraedts J, Montag M, Magli MC, Repping S, Handyside A, Staessen C, Harper J, Schmutzler A, Collins J, Goossens V, van der Ven H, Vesela K, Gianaroli L**, Polar body array CGH for prediction of the status of the corresponding oocyte. Part I: clinical results, *Hum Reprod* 26:3173, 2011.
746. **Nikas G, Ao A, Winston RM, Handyside AH**, Compaction and surface polarity in the human embryo in vitro, *Biol Reprod* 55:32, 1996.
747. **Scott KL, Hong KH, Scott RT Jr**, Selecting the optimal time to perform biopsy for preimplantation genetic testing, *Fertil Steril* 100:608, 2013.
748. **Goossens V, De Rycke M, De Vos A, Staessen C, Michiels A, Verpoest W, Van Steirteghem A, Bertrand C, Liebaers I, Devroey P, Sermon K**, Diagnostic efficiency, embryonic development and clinical outcome after the biopsy of one or two blastomeres for preimplantation genetic diagnosis, *Hum Reprod* 23:481, 2008.
749. **Scott RT Jr, Upham KM, Forman EJ, Zhao T, Treff NR**, Cleavage-stage biopsy significantly impairs human embryonic implantation potential while blastocyst biopsy does not: a randomized and paired clinical trial, *Fertil Steril* 100:624, 2013.
750. **Damario MA, Barmat L, Liu HC, Davis OK, Rosenwaks Z**, Dual suppression with oral contraceptives and gonadotrophin releasing-hormone agonists improves in-vitro fertilization outcome in high responder patients, *Hum Reprod* 12:2359, 1997.
751. **De Vos A, Staessen C, De Rycke M, Verpoest W, Haentjens P, Devroey P, Liebaers I, Van de Velde H**, Impact of cleavage-stage embryo biopsy in view of PGD on human blastocyst implantation: a prospective cohort of single embryo transfers, *Hum Reprod* 24:2988, 2009.
752. **Dokras A, Sargent IL, Gardner RL, Barlow DH**, Human trophectoderm biopsy and secretion of chorionic gonadotrophin, *Hum Reprod* 6:1453, 1991.
753. **Carson SA, Gentry WL, Smith AL, Buster JE**, Trophectoderm micro biopsy in murine blastocysts: comparison of four methods, *J Assist Reprod Genet* 10:427, 1993.
754. **Wilton L, Voullaire L, Sargeant P, Williamson R, McBain J**, Preimplantation aneuploidy screening using comparative genomic hybridization or fluorescence in situ hybridization of embryos from patients with recurrent implantation failure, *Fertil Steril* 80:860, 2003.
755. **Jericho H, Wilton L, Gook DA, Edgar DH**, A modified cryopreservation method increases the survival of human biopsied cleavage stage embryos, *Hum Reprod* 18:568, 2003.
756. **Coates A, Kung A, Mounts E, Hesla J, Bankowski B, Barbieri E, Ata B, Cohen J, Munne S**, Optimal euploid embryo transfer strategy, fresh versus frozen, after preimplantation genetic screening with next generation sequencing: a randomized controlled trial, *Fertil Steril* 107:723.e3, 2017.
757. **Verlinsky Y, Rechitsky S, Verlinsky O, Masciangelo C, Lederer K, Kuliev A**, Preimplantation diagnosis for early-onset Alzheimer disease caused by V717L mutation, *JAMA* 287:1018, 2002.
758. **Ao A, Wells D, Handyside AH, Winston RM, Delhanty JD**, Preimplantation genetic diagnosis of inherited cancer: familial adenomatous polyposis coli, *J Assist Reprod Genet* 15:140, 1998.
759. **Verlinsky Y, Rechitsky S, Verlinsky O, Xu K, Schattman G, Masciangelo C, Ginberg N, Strom C, Rosenwaks Z, Kuliev A**, Preimplantation diagnosis for p53 tumour suppressor gene mutations, *Reprod Biomed Online* 2:102, 2001.
760. **Verlinsky Y, Rechitsky S, Schoolcraft W, Strom C, Kuliev A**, Preimplantation diagnosis for Fanconi anemia combined with HLA matching, *JAMA* 285:3130, 2001.
761. **Handyside AH, Harton GL, Mariani B, Thornhill AR, Affara N, Shaw MA, Griffin DK**, Karyomapping: a universal method for genome wide analysis of genetic disease based on mapping crossovers between parental haplotypes, *J Med Genet* 47:651, 2010.
762. **Lee VCY, Chow JFC, Yeung WSB, Ho PC**, Preimplantation genetic diagnosis for monogenic diseases, *Best Pract Res Clin Obstet Gynaecol* 44:68, 2017.
763. **Treff NR, Fedick A, Tao X, Devkota B, Taylor D, Scott RT Jr**, Evaluation of targeted next-generation

sequencing-based preimplantation genetic diagnosis of monogenic disease, *Fertil Steril* 99:1377.e6, 2013.

764. **Goldman KN, Nazem T, Berkeley A, Palter S, Grifo JA**, Preimplantation Genetic Diagnosis (PGD) for monogenic disorders: the value of concurrent aneuploidy screening, *J Genet Couns* 25:1327, 2016.
765. **Iews M, Tan J, Taskin O, Alfaraj S, AbdelHafez FF, Abdallah AH, Bedaiwy MA**, Does preimplantation genetic diagnosis improve reproductive outcome in couples with recurrent pregnancy loss owing to structural chromosomal rearrangement? A systematic review, *Reprod Biomed Online* 36:677, 2018.
766. **Ikuma S, Sato T, Sugiura-Ogasawara M, Nagayoshi M, Tanaka A, Takeda S**, Preimplantation genetic diagnosis and natural conception: a comparison of live birth rates in patients with recurrent pregnancy loss associated with translocation, *PLoS One* 10:e0129958, 2015.
767. **Bedaiwy MA, Maithripala SI, Durland US, Havelock J, Kashyap S, Hitkari J, Lisonkova S**, Reproductive outcomes of couples with recurrent pregnancy loss due to parental chromosome rearrangement, *Fertil Steril* 106:e343, 2016.
768. **Goddijn M, Joosten JH, Knegt AC, van der Veen F, Franssen MT, Bonsel GJ, Leschot NJ**, Clinical relevance of diagnosing structural chromosome abnormalities in couples with repeated miscarriage, *Hum Reprod* 19:1013, 2004.
769. **Stephenson MD, Sierra S**, Reproductive outcomes in recurrent pregnancy loss associated with a parental carrier of a structural chromosome rearrangement, *Hum Reprod* 21:1076, 2006.
770. **Sugiura-Ogasawara M, Ozaki Y, Sato T, Suzumori N, Suzumori K**, Poor prognosis of recurrent aborters with either maternal or paternal reciprocal translocations, *Fertil Steril* 81:367, 2004.
771. **Menezo YJ, Bellec V, Zaroukian A, Benkhalifa M**, Embryo selection by IVF, co-culture and transfer at the blastocyst stage in case of translocation, *Hum Reprod* 12:2802, 1997.
772. **Magli MC, Gianaroli L, Ferraretti AP**, Chromosomal abnormalities in embryos, *Mol Cell Endocrinol* 183(Suppl 1):S29, 2001.
773. **Mastenbroek S, Twisk M, van der Veen F, Repping S**, Preimplantation genetic screening: a systematic review and meta-analysis of RCTs, *Hum Reprod Update* 17:454, 2011.
774. **Rubio C, Bellver J, Rodrigo L, Castillon G, Guillen A, Vidal C, Giles J, Ferrando M, Cabanillas S, Remohi J, Pellicer A, Simon C**, In vitro fertilization with preimplantation genetic diagnosis for aneuploidies in advanced maternal age: a randomized, controlled study, *Fertil Steril* 107:1122, 2017.
775. **Hardarson T, Hanson C, Lundin K, Hillensjo T, Nilsson L, Stevic J, Reisner E, Borg K, Wikland M, Bergh C**, Preimplantation genetic screening in women of advanced maternal age caused a decrease in clinical pregnancy rate: a randomized controlled trial, *Hum Reprod* 23:2806, 2008.
776. **Mastenbroek S, Twisk M, van Echten-Arends J, Sikkema-Raddatz B, Korevaar JC, Verhoeve HR, Vogel NE, Arts EG, de Vries JW, Bossuyt PM, Buys CH, Heineman MJ, Repping S, van der Veen F**, In vitro fertilization with preimplantation genetic screening, *N Engl J Med* 357:9, 2007.
777. **Verpoest W, Staessen C, Bossuyt PM, Goossens V, Altarescu G, Bonduelle M, Devesa M, Eldar-Geva T, Gianaroli L, Griesinger G, Kakourou G, Kokkali G, Liebenthron J, Magli MC, Parriego M, Schmutzler AG, Tobler M, van der Ven K, Geraedts J, Sermon K**, Preimplantation genetic testing for aneuploidy by microarray analysis of polar bodies in advanced maternal age: a randomized clinical trial, *Hum Reprod* 33:1767, 2018.
778. **Yang Z, Liu J, Collins GS, Salem SA, Liu X, Lyle SS, Peck AC, Sills ES, Salem RD**, Selection of single blastocysts for fresh transfer via standard morphology assessment alone and with array CGH for good prognosis IVF patients: results from a randomized pilot study, *Mol Cytogenet* 5:24, 2012.
779. **Forman EJ, Hong KH, Ferry KM, Tao X, Taylor D, Levy B, Treff NR, Scott RT Jr**, In vitro fertilization with single euploid blastocyst transfer: a randomized controlled trial, *Fertil Steril* 100:100.e1, 2013.
780. **Forman EJ, Hong KH, Fransiak JM, Scott RT Jr**, Obstetrical and neonatal outcomes from the BEST Trial: single embryo transfer with aneuploidy screening improves outcomes after in vitro fertilization without compromising delivery rates, *Am J Obstet Gynecol* 210:157.e1, 2014.
781. **Scott RT Jr, Upham KM, Forman EJ, Hong KH, Scott KL, Taylor D, Tao X, Treff NR**, Blastocyst biopsy with comprehensive chromosome screening and fresh embryo transfer significantly increases in vitro fertilization implantation and delivery rates: a randomized controlled trial, *Fertil Steril* 100:697, 2013.

782. **Munne S, Kaplan B, Frattarelli JL, Gysler M, Child TJ, Nakhuda G, Shamma FN, Silverberg K, Kalista T, Oliver K, Katz-Jaffe MG, Wells D, Gordon T, Willman S**, Global multicenter randomized controlled trial comparing single embryo transfer with embryo selected by preimplantation genetic screening using next-generation sequencing versus morphologic assessment, *Fertil Steril* 108:e19, 2017.
783. **Greco E, Minasi MG, Fiorentino F**, Healthy babies after intrauterine transfer of mosaic aneuploid blastocysts, *N Engl J Med* 373:2089, 2015.
784. **Edwards RG, Fishel SB, Cohen J, Fehilly CB, Purdy JM, Slater JM, Steptoe PC, Webster JM**, Factors influencing the success of in vitro fertilization for alleviating human infertility, *J In Vitro Fert Embryo Transf* 1:3, 1984.
785. **Kovacs GT**, Which factors are important for successful embryo transfer after in-vitro fertilization? *Hum Reprod* 14:2679, 1999.
786. **Practice Committee of the American Society for Reproductive Medicine. Electronic address: ASRM@asrm.org; Practice Committee of the American Society for Reproductive Medicine**, Performing the embryo transfer: a guideline, *Fertil Steril* 107:882, 2017.
787. **Karande VC, Morris R, Chapman C, Rinehart J, Gleicher N**, Impact of the “physician factor” on pregnancy rates in a large assisted reproductive technology program: do too many cooks spoil the broth? *Fertil Steril* 71:1001, 1999.
788. **Hearns-Stokes RM, Miller BT, Scott L, Creuss D, Chakraborty PK, Segars JH**, Pregnancy rates after embryo transfer depend on the provider at embryo transfer, *Fertil Steril* 74:80, 2000.
789. **Angelini A, Brusco GF, Barnocchi N, El-Danasouri I, Pacchiarotti A, Selman HA**, Impact of physician performing embryo transfer on pregnancy rates in an assisted reproductive program, *J Assist Reprod Genet* 23:329, 2006.
790. **Toth TL, Lee MS, Bendikson KA, Reindollar RH; American Society for Reproductive Medicine Embryo Transfer Advisory Panel**, Embryo transfer techniques: an American Society for Reproductive Medicine survey of current Society for Assisted Reproductive Technology practices, *Fertil Steril* 107:1003, 2017.
791. **Practice Committee of the American Society for Reproductive Medicine. Electronic address: ASRM@asrm.org, Penzias A, Bendikson K, Butts S, Coutifaris C, Falcone T, Fossom G, Gitlin S, Gracia C, Hansen K, Mersereau J, Odem R, Rebar R, Reindollar R, Rosen M, Sandlow J, Vernon M**, ASRM standard embryo transfer protocol template: a committee opinion, *Fertil Steril* 107:897, 2017.
792. **Mansour R, Aboulghar M, Serour G**, Dummy embryo transfer: a technique that minimizes the problems of embryo transfer and improves the pregnancy rate in human in vitro fertilization, *Fertil Steril* 54:678, 1990.
793. **Visser DS, Fourie FL, Kruger HF**, Multiple attempts at embryo transfer: effect on pregnancy outcome in an in vitro fertilization and embryo transfer program, *J Assist Reprod Genet* 10:37, 1993.
794. **Abusheikha N, Lass A, Akagbosu F, Brinsden P**, How useful is cervical dilatation in patients with cervical stenosis who are participating in an in vitro fertilization-embryo transfer program? The Bourn Hall experience, *Fertil Steril* 72:610, 1999.
795. **Yanushpolsky EH, Ginsburg ES, Fox JH, Stewart EA**, Transcervical placement of a Malecot catheter after hysteroscopic evaluation provides for easier entry into the endometrial cavity for women with histories of difficult intrauterine inseminations and/or embryo transfers: a prospective case series, *Fertil Steril* 73:402, 2000.
796. **Groutz A, Lessing JB, Wolf Y, Yovel I, Azem F, Amit A**, Cervical dilatation during ovum pick-up in patients with cervical stenosis: effect on pregnancy outcome in an in vitro fertilization-embryo transfer program, *Fertil Steril* 67: 909, 1997.
797. **Glatstein IZ, Pang SC, McShane PM**, Successful pregnancies with the use of laminaria tents before embryo transfer for refractory cervical stenosis, *Fertil Steril* 67:1172, 1997.
798. **Schoolcraft WB, Surrey ES, Gardner DK**, Embryo transfer: techniques and variables affecting success, *Fertil Steril* 76:863, 2001.
799. **Woolcott R, Stanger J**, Potentially important variables identified by transvaginal ultrasound-guided embryo transfer, *Hum Reprod* 12:963, 1997.
800. **Sundstrom P, Wramby H, Persson PH, Liedholm P**, Filled bladder simplifies human embryo transfer, *Br J*

Obstet Gynaecol 91:506, 1984.

801. **Lewin A, Schenker JG, Avrech O, Shapira S, Safran A, Friedler S**, The role of uterine straightening by passive bladder distension before embryo transfer in IVF cycles, *J Assist Reprod Genet* 14:32, 1997.
802. **Teixeira DM, Dasso LA, Vieira CV, Barbosa MA, Coelho Neto MA, Natri CO, Martins WP**, Ultrasound guidance during embryo transfer: a systematic review and meta-analysis of randomized controlled trials, *Ultrasound Obstet Gynecol* 45:139, 2015.
803. **Brown J, Buckingham K, Buckett W, Abou-Setta AM**, Ultrasound versus “clinical touch” for catheter guidance during embryo transfer in women, *Cochrane Database Syst Rev* (3):CD006107, 2016.
804. **Goudas VT, Hammitt DG, Damario MA, Session DR, Singh AP, Dumesic DA**, Blood on the embryo transfer catheter is associated with decreased rates of embryo implantation and clinical pregnancy with the use of in vitro fertilization-embryo transfer, *Fertil Steril* 70:878, 1998.
805. **Mansour RT, Aboulghar MA, Serour GI, Amin YM**, Dummy embryo transfer using methylene blue dye, *Hum Reprod* 9:1257, 1994.
806. **Fanchin R, Harmas A, Benaoudia F, Lundkvist U, Olivennes F, Frydman R**, Microbial flora of the cervix assessed at the time of embryo transfer adversely affects in vitro fertilization outcome, *Fertil Steril* 70:866, 1998.
807. **Moini A, Kiani K, Bahmanabadi A, Akhoond M, Akhlaghi A**, Improvement in pregnancy rate by removal of cervical discharge prior to embryo transfer in ICSI cycles: a randomised clinical trial, *Aust N Z J Obstet Gynaecol* 51:315, 2011.
808. **Eskandar MA, Abou-Setta AM, El-Amin M, Almushait MA, Sobande AA**, Removal of cervical mucus prior to embryo transfer improves pregnancy rates in women undergoing assisted reproduction, *Reprod Biomed Online* 14: 308, 2007.
809. **Visschers BA, Bots RS, Peeters MF, Mol BW, van Dessel HJ**, Removal of cervical mucus: effect on pregnancy rates in IVF/ICSI, *Reprod Biomed Online* 15: 310, 2007.
810. **Lavie O, Margalioth EJ, Geva-Eldar T, Ben-Chetrit A**, Ultrasonographic endometrial changes after intrauterine insemination: a comparison of two catheters, *Fertil Steril* 68:731, 1997.
811. **Ata B, Isiklar A, Balaban B, Urman B**, Prospective randomized comparison of Wallace and Labotect embryo transfer catheters, *Reprod Biomed Online* 14: 471, 2007.
812. **Abdelmassih VG, Neme RM, Dozortsev D, Abdelmassih S, Diamond MP, Abdelmassih R**, Location of the embryo-transfer catheter guide before the internal uterine os improves the outcome of in vitro fertilization, *Fertil Steril* 88:499, 2007.
813. **Kato O, Takatsuka R, Asch RH**, Transvaginal-transmyometrial embryo transfer: the Towako method; experiences of 104 cases, *Fertil Steril* 59:51, 1993.
814. **Sharif K, Afnan M, Lenton W, Bilalis D, Hunjan M, Khalaf Y**, Transmyometrial embryo transfer after difficult immediate mock transcervical transfer, *Fertil Steril* 65:1071, 1996.
815. **Groutz A, Lessing JB, Wolf Y, Azem F, Yovel I, Amit A**, Comparison of transmyometrial and transcervical embryo transfer in patients with previously failed in vitro fertilization-embryo transfer cycles and/or cervical stenosis, *Fertil Steril* 67:1073, 1997.
816. **Biervliet FP, Lesny P, Maguiness SD, Robinson J, Killick SR**, Transmyometrial embryo transfer and junctional zone contractions, *Hum Reprod* 17:347, 2002.
817. **Coroleu B, Barri PN, Carreras O, Martinez F, Parriego M, Hereter L, Parera N, Veiga A, Balasch J**, The influence of the depth of embryo replacement into the uterine cavity on implantation rates after IVF: a controlled, ultrasound-guided study, *Hum Reprod* 17:341, 2002.
818. **Kwon H, Choi DH, Kim EK**, Absolute position versus relative position in embryo transfer: a randomized controlled trial, *Reprod Biol Endocrinol* 13: 78, 2015.
819. **Pacchiarotti A, Mohamed MA, Micara G, Tranquilli D, Linari A, Espinola SM, Aragona C**, The impact of the depth of embryo replacement on IVF outcome, *J Assist Reprod Genet* 24:189, 2007.
820. **Oliveira JB, Martins AM, Baruffi RL, Mauri AL, Petersen CG, Felipe V, Contart P, Pontes A, Franco Junior JG**, Increased implantation and pregnancy rates obtained by placing the tip of the transfer catheter in the central area of the endometrial cavity, *Reprod Biomed Online* 9:435, 2004.

821. **Tiras B, Polat M, Korucuoglu U, Zeyneloglu HB, Yarali H**, Impact of embryo replacement depth on in vitro fertilization and embryo transfer outcomes, *Fertil Steril* 94:1341, 2010.
822. **Cenksoy PO, Ficicioglu C, Yesiladali M, Akcin OA, Kaspar C**, The importance of the length of uterine cavity, the position of the tip of the inner catheter and the distance between the fundal endometrial surface and the air bubbles as determinants of the pregnancy rate in IVF cycles, *Eur J Obstet Gynecol Reprod Biol* 172:46, 2014.
823. **Yovich JL, Turner SR, Murphy AJ**, Embryo transfer technique as a cause of ectopic pregnancies in in vitro fertilization, *Fertil Steril* 44:318, 1985.
824. **Nazari A, Askari HA, Check JH, O'Shaughnessy A**, Embryo transfer technique as a cause of ectopic pregnancy in in vitro fertilization, *Fertil Steril* 60:919, 1993.
825. **Bennett S, Waterstone J, Parsons J, Creighton S**, Two cases of cervical pregnancy following in vitro fertilization and embryo transfer to the lower uterine cavity, *J Assist Reprod Genet* 10:100, 1993.
826. **Poindexter AN, III, Thompson DJ, Gibbons WE, Findley WE, Dodson MG, Young RL**, Residual embryos in failed embryo transfer, *Fertil Steril* 46:262, 1986.
827. **Meldrum DR, Chetkowski R, Steingold KA, de Ziegler D, Cedars MI, Hamilton M**, Evolution of a highly successful in vitro fertilization-embryo transfer program, *Fertil Steril* 48:86, 1987.
828. **Khan I, Staessen C, Devroey P, Van Steirteghem AC**, Human serum albumin versus serum: a comparative study on embryo transfer medium, *Fertil Steril* 56:98, 1991.
829. **Menezo Y, Arnal F, Humeau C, Ducret L, Nicollet B**, Increased viscosity in transfer medium does not improve the pregnancy rates after embryo replacement, *Fertil Steril* 52:680, 1989.
830. **Bontekoe S, Heineman MJ, Johnson N, Blake D**, Adherence compounds in embryo transfer media for assisted reproductive technologies, *Cochrane Database Syst Rev* (2):CD007421, 2014.
831. **Urman B, Yakin K, Ata B, Isiklar A, Balaban B**, Effect of hyaluronan-enriched transfer medium on implantation and pregnancy rates after day 3 and day 5 embryo transfers: a prospective randomized study, *Fertil Steril* 90:604, 2008.
832. **Fancsovits P, Lehner A, Murber A, Kaszas Z, Rigo J, Urbancsek J**, Effect of hyaluronan-enriched embryo transfer medium on IVF outcome: a prospective randomized clinical trial, *Arch Gynecol Obstet* 291:1173, 2015.
833. **Safari S, Razi MH, Safari S, Razi Y**, Routine use of EmbryoGlue(®) as embryo transfer medium does not improve the ART outcomes, *Arch Gynecol Obstet* 291:433, 2015.
834. **Nishihara T, Morimoto Y**, Evaluation of transfer media containing different concentrations of hyaluronan for human in vitro fertilization, *Reprod Med Biol* 16:349, 2017.
835. **Fu W, Yu M, Zhang XJ**, Effect of hyaluronic acid-enriched transfer medium on frozen-thawed embryo transfer outcomes, *J Obstet Gynaecol Res* 44:747, 2018.
836. **Eytan O, Elad D, Jaffa AJ**, Evaluation of the embryo transfer protocol by a laboratory model of the uterus, *Fertil Steril* 88:485, 2007.
837. **Eytan O, Elad D, Jaffa AJ**, Bioengineering studies of the embryo transfer procedure, *Ann N Y Acad Sci* 1101:21, 2007.
838. **Eytan O, Zaretsky U, Jaffa AJ, Elad D**, In vitro simulations of embryo transfer in a laboratory model of the uterus, *J Biomech* 40:1073, 2007.
839. **Yaniv S, Jaffa AJ, Elad D**, Modeling embryo transfer into a closed uterine cavity, *J Biomech Eng* 134:111003, 2012.
840. **Alvero R, Hearn-Stokes RM, Catherino WH, Leondires MP, Segars JH**, The presence of blood in the transfer catheter negatively influences outcome at embryo transfer, *Hum Reprod* 18:1848, 2003.
841. **Awonuga A, Nabi A, Govindbhai J, Birch H, Stewart B**, Contamination of embryo transfer catheter and treatment outcome in in vitro fertilization, *J Assist Reprod Genet* 15:198, 1998.
842. **Ebner T, Yaman C, Moser M, Sommergruber M, Polz W, Tews G**, The ineffective loading process of the embryo transfer catheter alters implantation and pregnancy rates, *Fertil Steril* 76:630, 2001.
843. **Listijono DR, Boylan T, Cooke S, Kilani S, Chapman MG**, An analysis of the impact of embryo transfer difficulty on live birth rates, using a standardised grading system, *Hum Fertil (Camb)* 16:211, 2013.

844. **Moragianni VA, Cohen JD, Smith SE, Schinfeld JS, Somkuti SG, Lee A, Barmat LI**, Effect of macroscopic or microscopic blood and mucus on the success rates of embryo transfers, *Fertil Steril* 93:570, 2010.
845. **Nabi A, Awonuga A, Birch H, Barlow S, Stewart B**, Multiple attempts at embryo transfer: does this affect in-vitro fertilization treatment outcome? *Hum Reprod* 12:1188, 1997.
846. **Phillips JA, Martins WP, Nastri CO, Raine-Fenning NJ**, Difficult embryo transfers or blood on catheter and assisted reproductive outcomes: a systematic review and meta-analysis, *Eur J Obstet Gynecol Reprod Biol* 168:121, 2013.
847. **Munoz M, Meseguer M, Lizan C, Ayllon Y, Perez-Cano I, Garrido N**, Bleeding during transfer is the only parameter of patient anatomy and embryo quality that affects reproductive outcome: a prospective study, *Fertil Steril* 92:953, 2009.
848. **Rhodes TL, McCoy TP, Higdon HL III, Boone WR**, Factors affecting assisted reproductive technology (ART) pregnancy rates: a multivariate analysis, *J Assist Reprod Genet* 22:335, 2005.
849. **Sallam HN, Agameya AF, Rahman AF, Ezzeldin F, Sallam AN**, Ultrasound measurement of the uterocervical angle before embryo transfer: a prospective controlled study, *Hum Reprod* 17:1767, 2002.
850. **El-Shawarby SA, Ravhon A, Skull J, Ellenbogen A, Trew G, Lavery S**, A prospective randomized controlled trial of Wallace and Rocket embryo transfer catheters, *Reprod Biomed Online* 17:549, 2008.
851. **Oraif A, Hollet-Caines J, Feyles V, Rebel M, Abduljabar H**, Do multiple attempts at embryo transfer affect clinical pregnancy rates? *J Obstet Gynaecol Can* 36:406, 2014.
852. **Lee HC, Seifer DB, Shelden RM**, Impact of retained embryos on the outcome of assisted reproductive technologies, *Fertil Steril* 82:334, 2004.
853. **Tur-Kaspa I, Yuval Y, Bider D, Levron J, Shulman A, Dor J**, Difficult or repeated sequential embryo transfers do not adversely affect in-vitro fertilization pregnancy rates or outcome, *Hum Reprod* 13:2452, 1998.
854. **Vicdan K, Isik AZ, Akarsu C, Sozen E, Caglar G, Dingiloglu B, Tuncay G**, The effect of retained embryos on pregnancy outcome in an in vitro fertilization and embryo transfer program, *Eur J Obstet Gynecol Reprod Biol* 134: 79, 2007.
855. **Yi HJ, Koo HS, Cha SH, Kim HO, Park CW, Song IO**, Reproductive outcomes of retransferring retained embryos in blastocyst transfer cycles, *Clin Exp Reprod Med* 43:133, 2016.
856. **Silberstein T, Trimarchi JR, Shackelton R, Weitzen S, Frankfurter D, Plosker S**, Ultrasound-guided miduterine cavity embryo transfer is associated with a decreased incidence of retained embryos in the transfer catheter, *Fertil Steril* 84:1510, 2005.
857. **Gaikwad S, Garrido N, Cobo A, Pellicer A, Remohi J**, Bed rest after embryo transfer negatively affects in vitro fertilization: a randomized controlled clinical trial, *Fertil Steril* 100:729, 2013.
858. **Li B, Zhou H, Li W**, Bed rest after embryo transfer, *Eur J Obstet Gynecol Reprod Biol* 155:125, 2011.
859. **Craciunas L, Tsampras N**, Bed rest following embryo transfer might negatively affect the outcome of IVF/ICSI: a systematic review and meta-analysis, *Hum Fertil (Camb)* 19:16, 2016.
860. **Templeton A, Morris JK**, Reducing the risk of multiple births by transfer of two embryos after in vitro fertilization, *N Engl J Med* 339:573, 1998.
861. **Schieve LA, Peterson HB, Meikle SF, Jeng G, Danel I, Burnett NM, Wilcox LS**, Live-birth rates and multiple-birth risk using in vitro fertilization, *JAMA* 282:1832, 1999.
862. **Engmann L, Maconochie N, Tan SL, Bekir J**, Trends in the incidence of births and multiple births and the factors that determine the probability of multiple birth after IVF treatment, *Hum Reprod* 16:2598, 2001.
863. **Santana DS, Cecatti JG, Surita FG, Silveira C, Costa ML, Souza JP, Mazhar SB, Jayaratne K, Qureshi Z, Sousa MH, Vogel JP; WHO Multicountry Survey on Maternal and Newborn Health Research Network**, Twin pregnancy and severe maternal outcomes: the World Health Organization multicountry survey on maternal and newborn health, *Obstet Gynecol* 127:631, 2016.
864. **Bromer JG, Ata B, Seli M, Lockwood CJ, Seli E**, Preterm deliveries that result from multiple pregnancies associated with assisted reproductive technologies in the USA: a cost analysis, *Curr Opin Obstet Gynecol* 23:168, 2011.
865. **Ata B, Seli E**, Economics of assisted reproductive technologies, *Curr Opin Obstet Gynecol* 22:183, 2010.

866. **Jain T, Harlow BL, Hornstein MD**, Insurance coverage and outcomes of in vitro fertilization, *N Engl J Med* 347:661, 2002.
867. **Provost MP, Thomas SM, Yeh JS, Hurd WW, Eaton JL**, State insurance mandates and multiple birth rates after in vitro fertilization, *Obstet Gynecol* 128:1205, 2016.
868. **Styer AK, Luke B, Vitek W, Christianson MS, Baker VL, Christy AY, Polotsky AJ**, Factors associated with the use of elective single-embryo transfer and pregnancy outcomes in the United States, 2004-2012, *Fertil Steril* 106:80, 2016.
869. **Cabello Y, Gomez-Palomares JL, Castilla JA, Hernandez J, Marqueta J, Pareja A, Luceno F, Hernandez E, Coroleu B**, Impact of the Spanish Fertility Society guidelines on the number of embryos to transfer, *Reprod Biomed Online* 21:667, 2010.
870. **Bissonnette F, Phillips SJ, Gunby J, Holzer H, Mahutte N, St-Michel P, Kadoch IJ**, Working to eliminate multiple pregnancies: a success story in Quebec, *Reprod Biomed Online* 23:500, 2011.
871. **Urman B, Yakin K**, New Turkish legislation on assisted reproductive techniques and centres: a step in the right direction? *Reprod Biomed Online* 21:729, 2010.
872. **Mancuso AC, Boulet SL, Duran E, Munch E, Kissin DM, Van Voorhis BJ**, Elective single embryo transfer in women less than age 38 years reduces multiple birth rates, but not live birth rates, in United States fertility clinics, *Fertil Steril* 106:1107, 2016.
873. **American Society for Reproductive Medicine**, Guidelines on Number of Embryos Transferred, American Society for Reproductive Medicine, Birmingham, 1998.
874. **Combelles CM, Orasanu B, Ginsburg ES, Racowsky C**, Optimum number of embryos to transfer in women more than 40 years of age undergoing treatment with assisted reproductive technologies, *Fertil Steril* 84:1637, 2005.
875. **Stern JE, Goldman MB, Hatasaka H, MacKenzie TA, Surrey ES, Racowsky C; Society for Assisted Reproductive Technology Writing Group**, Optimizing the number of cleavage stage embryos to transfer on day 3 in women 38 years of age and older: a Society for Assisted Reproductive Technology database study, *Fertil Steril* 91:767, 2009.
876. **Practice Committee of the American Society for Reproductive Medicine. Electronic address: ASRM@asrm.org; Practice Committee of the Society for Assisted Reproductive Technology**, Guidance on the limits to the number of embryos to transfer: a committee opinion, *Fertil Steril* 107:901, 2017.
877. **Pritts EA, Atwood AK**, Luteal phase support in infertility treatment: a meta-analysis of the randomized trials, *Hum Reprod* 17:2287, 2002.
878. **Beckers NG, Macklon NS, Eijkemans MJ, Ludwig M, Felberbaum RE, Diedrich K, Bustion S, Loumaye E, Fauser BC**, Nonsupplemented luteal phase characteristics after the administration of recombinant human chorionic gonadotropin, recombinant luteinizing hormone, or gonadotropin-releasing hormone (GnRH) agonist to induce final oocyte maturation in in vitro fertilization patients after ovarian stimulation with recombinant follicle-stimulating hormone and GnRH antagonist cotreatment, *J Clin Endocrinol Metab* 88:4186, 2003.
879. **Practice Committee of the American Society for Reproductive Medicine**, Progesterone supplementation during the luteal phase and in early pregnancy in the treatment of infertility: an educational bulletin, *Fertil Steril* 89:789, 2008.
880. **Hubayter ZR, Muasher SJ**, Luteal supplementation in in vitro fertilization: more questions than answers, *Fertil Steril* 89:749, 2008.
881. **Glujovsky D, Pesce R, Fiszbajn G, Sueldo C, Hart RJ, Ciapponi A**, Endometrial preparation for women undergoing embryo transfer with frozen embryos or embryos derived from donor oocytes, *Cochrane Database Syst Rev* (1):CD006359, 2010.
882. **Barbosa MW, Silva LR, Navarro PA, Ferriani RA, Nastri CO, Martins WP**, Dydrogesterone vs progesterone for luteal-phase support: systematic review and meta-analysis of randomized controlled trials, *Ultrasound Obstet Gynecol* 48:161, 2016.
883. **Tournaye H, Sukhikh GT, Kahler E, Griesinger G**, A Phase III randomized controlled trial comparing the efficacy, safety and tolerability of oral dydrogesterone versus micronized vaginal progesterone for luteal



support in in vitro fertilization, *Hum Reprod* 32:1019, 2017.

884. **van der Linden M, Buckingham K, Farquhar C, Kremer JA, Metwally M**, Luteal phase support for assisted reproduction cycles, *Cochrane Database Syst Rev* (7):CD009154, 2015.
885. **Kohls G, Ruiz F, Martinez M, Hauzman E, de la Fuente G, Pellicer A, Garcia-Velasco JA**, Early progesterone cessation after in vitro fertilization/intracytoplasmic sperm injection: a randomized, controlled trial, *Fertil Steril* 98:858, 2012.
886. **Pan SP, Chao KH, Huang CC, Wu MY, Chen MJ, Chang CH, Yang JH, Yang YS, Chen SU**, Early stop of progesterone supplementation after confirmation of pregnancy in IVF/ICSI fresh embryo transfer cycles of poor responders does not affect pregnancy outcome, *PLoS One* 13:e0201824, 2018.
887. **Vaisbuch E, de Ziegler D, Leong M, Weissman A, Shoham Z**, Luteal-phase support in assisted reproduction treatment: real-life practices reported worldwide by an updated website-based survey, *Reprod Biomed Online* 28:330, 2014.
888. **Jee BC, Suh CS, Kim SH, Kim YB, Moon SY**, Effects of estradiol supplementation during the luteal phase of in vitro fertilization cycles: a meta-analysis, *Fertil Steril* 93:428, 2010.
889. **Ata B, Kucuk M, Seyhan A, Urman B**, Effect of high-dose estrogen in luteal phase support on live birth rates after assisted reproduction treatment cycles, *J Reprod Med* 55:485, 2010.
890. **Trounson A, Mohr L**, Human pregnancy following cryopreservation, thawing and transfer of an eight-cell embryo, *Nature* 305:707, 1983.
891. **Practice Committee of American Society for Reproductive Medicine**, Ovarian hyperstimulation syndrome, *Fertil Steril* 90:S188, 2008.
892. **D'Angelo A, Amso N**, Embryo freezing for preventing ovarian hyperstimulation syndrome, *Cochrane Database Syst Rev*:CD002806, 2007.
893. **Kuwayama M**, Highly efficient vitrification for cryopreservation of human oocytes and embryos: the Cryotop method, *Theriogenology* 67:73, 2007.
894. **Vajta G, Nagy ZP, Cobo A, Conceicao J, Yovich J**, Vitrification in assisted reproduction: myths, mistakes, disbeliefs and confusion, *Reprod Biomed Online* 19(Suppl 3):1, 2009.
895. **Lin YP, Cassidenti DL, Chacon RR, Soubra SS, Rosen GF, Yee B**, Successful implantation of frozen sibling embryos is influenced by the outcome of the cycle from which they were derived, *Fertil Steril* 63:262, 1995.
896. **Pantos K, Stefanidis K, Pappas K, Kokkinopoulos P, Petroutsou K, Kokkali G, Stavrou D, Tzigounis V**, Cryopreservation of embryos, blastocysts, and pregnancy rates of blastocysts derived from frozen-thawed embryos and frozen-thawed blastocysts, *J Assist Reprod Genet* 18:579, 2001.
897. **Behr B, Gebhardt J, Lyon J, Milki AA**, Factors relating to a successful cryopreserved blastocyst transfer program, *Fertil Steril* 77:697, 2002.
898. **Senn A, Vozzi C, Chanson A, De Grandi P, Germond M**, Prospective randomized study of two cryopreservation policies avoiding embryo selection: the pronucleate stage leads to a higher cumulative delivery rate than the early cleavage stage, *Fertil Steril* 74:946, 2000.
899. **Oehninger S, Mayer J, Muasher S**, Impact of different clinical variables on pregnancy outcome following embryo cryopreservation, *Mol Cell Endocrinol* 169:73, 2000.
900. **Salumets A, Tuuri T, Makinen S, Vilska S, Husu L, Tainio R, Suikkari AM**, Effect of developmental stage of embryo at freezing on pregnancy outcome of frozen-thawed embryo transfer, *Hum Reprod* 18:1890, 2003.
901. **Kattera S, Shrivastav P, Craft I**, Comparison of pregnancy outcome of pronuclear- and multicellular-stage frozen-thawed embryo transfers, *J Assist Reprod Genet* 16:358, 1999.
902. **Rienzi L, Gracia C, Maggiulli R, LaBarbera AR, Kaser DJ, Ubaldi FM, Vanderpoel S, Racowsky C**, Oocyte, embryo and blastocyst cryopreservation in ART: systematic review and meta-analysis comparing slow-freezing versus vitrification to produce evidence for the development of global guidance, *Hum Reprod Update* 23:139, 2017.
903. **Li Z, Wang YA, Ledger W, Edgar DH, Sullivan EA**, Clinical outcomes following cryopreservation of blastocysts by vitrification or slow freezing: a population-based cohort study, *Hum Reprod* 29:2794, 2014.

904. **Mackens S, Santos-Ribeiro S, van de Vijver A, Racca A, Van Landuyt L, Tournaye H, Blockeel C**, Frozen embryo transfer: a review on the optimal endometrial preparation and timing, *Hum Reprod* 32:2234, 2017.
905. **Groenewoud ER, Cohlen BJ, Macklon NS**, Programming the endometrium for deferred transfer of cryopreserved embryos: hormone replacement versus modified natural cycles, *Fertil Steril* 109:768, 2018.
906. **Muasher SJ, Kruthoff C, Simonetti S, Oehninger S, Acosta AA, Jones GS**, Controlled preparation of the endometrium with exogenous steroids for the transfer of frozen-thawed pre-embryos in patients with anovulatory or irregular cycles, *Hum Reprod* 6:443, 1991.
907. **Simon A, Hurwitz A, Zentner BS, Bdolah Y, Laufer N**, Transfer of frozen-thawed embryos in artificially prepared cycles with and without prior gonadotrophin-releasing hormone agonist suppression: a prospective randomized study, *Hum Reprod* 13:2712, 1998.
908. **Remohi J, Gutierrez A, Cano F, Ruiz A, Simon C, Pellicer A**, Long oestradiol replacement in an oocyte donation programme, *Hum Reprod* 10:1387, 1995.
909. **Ghobara T, Gelbaya TA, Ayeleke RO**, Cycle regimens for frozen-thawed embryo transfer, *Cochrane Database Syst Rev* (7):CD003414, 2017.
910. **Santos-Ribeiro S, Polyzos NP, Lan VT, Siffain J, Mackens S, Van Landuyt L, Tournaye H, Blockeel C**, The effect of an immediate frozen embryo transfer following a freeze-all protocol: a retrospective analysis from two centres, *Hum Reprod* 31:2541, 2016.
911. **Lattes K, Checa MA, Vassena R, Brassesco M, Vermaeve V**, There is no evidence that the time from egg retrieval to embryo transfer affects live birth rates in a freeze-all strategy, *Hum Reprod* 32:368, 2017.
912. **Kulkarni AD, Jamieson DJ, Jones HW Jr, Kissin DM, Gallo MF, Macaluso M, Adashi EY**, Fertility treatments and multiple births in the United States, *N Engl J Med* 369:2218, 2013.
913. **Vahratian A, Schieve LA, Reynolds MA, Jeng G**, Live-birth rates and multiple-birth risk of assisted reproductive technology pregnancies conceived using thawed embryos, USA 1999-2000, *Hum Reprod* 18:1442, 2003.
914. **Wright V, Schieve LA, Vahratian A, Reynolds MA**, Monozygotic twinning associated with day 5 embryo transfer in pregnancies conceived after IVF, *Hum Reprod* 19:1831, 2004.
915. **Jain T, Missmer SA, Hornstein MD**, Trends in embryo-transfer practice and in outcomes of the use of assisted reproductive technology in the United States, *N Engl J Med* 350:1639, 2004.
916. **Pandey S, Shetty A, Hamilton M, Bhattacharya S, Maheshwari A**, Obstetric and perinatal outcomes in singleton pregnancies resulting from IVF/ICSI: a systematic review and meta-analysis, *Hum Reprod Update* 18:485, 2012.
917. **Helmerhorst FM, Perquin DA, Donker D, Keirse MJ**, Perinatal outcome of singletons and twins after assisted conception: a systematic review of controlled studies, *BMJ* 328:261, 2004.
918. **Jackson RA, Gibson KA, Wu YW, Croughan MS**, Perinatal outcomes in singletons following in vitro fertilization: a meta-analysis, *Obstet Gynecol* 103:551, 2004.
919. **McDonald SD, Han Z, Mulla S, Murphy KE, Beyene J, Ohlsson A**, Preterm birth and low birth weight among in vitro fertilization singletons: a systematic review and meta-analyses, *Eur J Obstet Gynecol Reprod Biol* 146:138, 2009.
920. **McDonald SD, Murphy K, Beyene J, Ohlsson A**, Perinatal outcomes of singleton pregnancies achieved by in vitro fertilization: a systematic review and meta-analysis, *J Obstet Gynaecol Can* 27:449, 2005.
921. **McGovern PG, Llorens AJ, Skurnick JH, Weiss G, Goldsmith LT**, Increased risk of preterm birth in singleton pregnancies resulting from in vitro fertilization-embryo transfer or gamete intrafallopian transfer: a meta-analysis, *Fertil Steril* 82:1514, 2004.
922. **Henningsen AA, Gissler M, Skjaerven R, Bergh C, Tiitinen A, Romundstad LB, Wennerholm UB, Lidegaard O, Nyboe Andersen A, Forman JL, Pinborg A**, Trends in perinatal health after assisted reproduction: a Nordic study from the CoNARTaS group, *Hum Reprod* 30:710, 2015.
923. **Henningsen AA, Wennerholm UB, Gissler M, Romundstad LB, Nygren KG, Tiitinen A, Skjaerven R, Nyboe Andersen A, Lidegaard O, Forman JL, Pinborg A**, Risk of stillbirth and infant deaths after assisted reproductive technology: a Nordic study from the CoNARTaS group, *Hum Reprod* 29: 1090, 2014.

924. **Messerlian C, Maclagan L, Basso O**, Infertility and the risk of adverse pregnancy outcomes: a systematic review and meta-analysis, *Hum Reprod* 28:125, 2013.
925. **Declercq E, Luke B, Belanoff C, Cabral H, Diop H, Gopal D, Hoang L, Kotelchuck M, Stern JE, Hornstein MD**, Perinatal outcomes associated with assisted reproductive technology: the Massachusetts Outcomes Study of Assisted Reproductive Technologies (MOSART), *Fertil Steril* 103:888, 2015.
926. **Pinborg A, Wennerholm UB, Romundstad LB, Loft A, Aittomaki K, Soderstrom-Anttila V, Nygren KG, Hazekamp J, Bergh C**, Why do singletons conceived after assisted reproduction technology have adverse perinatal outcome? Systematic review and meta-analysis, *Hum Reprod Update* 19:87, 2013.
927. **Ginstrom Ernstad E, Bergh C, Khatibi A, Kallen KB, Westlander G, Nilsson S, Wennerholm UB**, Neonatal and maternal outcome after blastocyst transfer: a population-based registry study, *Am J Obstet Gynecol* 214:378.e1, 2016.
928. **Pinborg A, Henningsen AA, Loft A, Malchau SS, Forman J, Andersen AN**, Large baby syndrome in singletons born after frozen embryo transfer (FET): is it due to maternal factors or the cryotechnique? *Hum Reprod* 29:618, 2014.
929. **Martin AS, Chang J, Zhang Y, Kawwass JF, Boulet SL, McKane P, Bernson D, Kissin DM, Jamieson DJ; States Monitoring Assisted Reproductive Technology Collaborative**, Perinatal outcomes among singletons after assisted reproductive technology with single-embryo or double-embryo transfer versus no assisted reproductive technology, *Fertil Steril* 107:954, 2017.
930. **Wennerholm UB, Henningsen AK, Romundstad LB, Bergh C, Pinborg A, Skjaerven R, Forman J, Gissler M, Nygren KG, Tiitinen A**, Perinatal outcomes of children born after frozen-thawed embryo transfer: a Nordic cohort study from the CoNARTaS group, *Hum Reprod* 28:2545, 2013.
931. **Hansen M, Bower C**, The impact of assisted reproductive technologies on intra-uterine growth and birth defects in singletons, *Semin Fetal Neonatal Med* 19:228, 2014.
932. **Sutcliffe AG, Ludwig M**, Outcome of assisted reproduction, *Lancet* 370:351, 2007.
933. **Hansen M, Bower C, Milne E, de Klerk N, Kurinczuk JJ**, Assisted reproductive technologies and the risk of birth defects—a systematic review, *Hum Reprod* 20:328, 2005.
934. **Hansen M, Kurinczuk JJ, Milne E, de Klerk N, Bower C**, Assisted reproductive technology and birth defects: a systematic review and meta-analysis, *Hum Reprod Update* 19:330, 2013.
935. **Rimm AA, Katayama AC, Diaz M, Katayama KP**, A meta-analysis of controlled studies comparing major malformation rates in IVF and ICSI infants with naturally conceived children, *J Assist Reprod Genet* 21:437, 2004.
936. **Wen J, Jiang J, Ding C, Dai J, Liu Y, Xia Y, Liu J, Hu Z**, Birth defects in children conceived by in vitro fertilization and intracytoplasmic sperm injection: a meta-analysis, *Fertil Steril* 97:1331.e1, 2012.
937. **Boulet SL, Kirby RS, Reefhuis J, Zhang Y, Sunderam S, Cohen B, Bernson D, Copeland G, Bailey MA, Jamieson DJ, Kissin DM**, Assisted reproductive technology and birth defects among liveborn infants in Florida, Massachusetts, and Michigan, 2000-2010, *JAMA Pediatr* 170:e154934, 2016.
938. **Heisey AS, Bell EM, Herdt-Losavio ML, Druschel C**, Surveillance of congenital malformations in infants conceived through assisted reproductive technology or other fertility treatments, *Birth Defects Res A Clin Mol Teratol* 103:119, 2015.
939. **Hwang SS, Dukhovny D, Gopal D, Cabral H, Missmer S, Diop H, Declercq E, Stern JE**, Health of infants after art-treated, subfertile, and fertile deliveries, *Pediatrics* 142, 2018.
940. **Davies MJ, Moore VM, Willson KJ, Van Essen P, Priest K, Scott H, Haan EA, Chan A**, Reproductive technologies and the risk of birth defects, *N Engl J Med* 366:1803, 2012.
941. **Zhu JL, Basso O, Obel C, Bille C, Olsen J**, Infertility, infertility treatment, and congenital malformations: Danish national birth cohort, *BMJ* 333:679, 2006.
942. **Rimm AA, Katayama AC, Katayama KP**, A meta-analysis of the impact of IVF and ICSI on major malformations after adjusting for the effect of subfertility, *J Assist Reprod Genet* 28:699, 2011.
943. **Chang AS, Moley KH, Wangler M, Feinberg AP, Debaun MR**, Association between Beckwith-Wiedemann syndrome and assisted reproductive technology: a case series of 19 patients, *Fertil Steril* 83:349, 2005.

944. **Halliday J, Oke K, Breheny S, Algar E, Amor DJ**, Beckwith-Wiedemann syndrome and IVF: a case-control study, *Am J Hum Genet* 75:526, 2004.
945. **Lim D, Bowdin SC, Tee L, Kirby GA, Blair E, Fryer A, Lam W, Oley C, Cole T, Brueton LA, Reik W, Macdonald F, Maher ER**, Clinical and molecular genetic features of Beckwith-Wiedemann syndrome associated with assisted reproductive technologies, *Hum Reprod* 24:741, 2009.
946. **Orstavik KH, Eiklid K, van der Hagen CB, Spetalen S, Kierulf K, Skjeldal O, Buiting K**, Another case of imprinting defect in a girl with Angelman syndrome who was conceived by intracytoplasmic semen injection, *Am J Hum Genet* 72:218, 2003.
947. **Ludwig M, Katalinic A, Gross S, Sutcliffe A, Varon R, Horsthemke B**, Increased prevalence of imprinting defects in patients with Angelman syndrome born to subfertile couples, *J Med Genet* 42:289, 2005.
948. **Bowdin S, Allen C, Kirby G, Brueton L, Afnan M, Barratt C, Kirkman-Brown J, Harrison R, Maher ER, Reardon W**, A survey of assisted reproductive technology births and imprinting disorders, *Hum Reprod* 22:3237, 2007.
949. **Doornbos ME, Maas SM, McDonnell J, Vermeiden JP, Hennekam RC**, Infertility, assisted reproduction technologies and imprinting disturbances: a Dutch study, *Hum Reprod* 22:2476, 2007.
950. **Strawn EY, Jr., Bick D, Swanson A**, Is it the patient or the IVF? Beckwith-Wiedemann syndrome in both spontaneous and assisted reproductive conceptions, *Fertil Steril* 94:754.e1, 2010.
951. **Ceelen M, van Weissenbruch MM, Roos JC, Vermeiden JP, van Leeuwen FE, Delemarre-van de Waal HA**, Body composition in children and adolescents born after in vitro fertilization or spontaneous conception, *J Clin Endocrinol Metab* 92:3417, 2007.
952. **Ceelen M, van Weissenbruch MM, Vermeiden JP, van Leeuwen FE, Delemarre-van de Waal HA**, Cardiometabolic differences in children born after in vitro fertilization: follow-up study, *J Clin Endocrinol Metab* 93:1682, 2008.
953. **Sakka SD, Loutradis D, Kanaka-Gantenbein C, Margeli A, Papastamataki M, Papassotiriou I, Chrousos GP**, Absence of insulin resistance and low-grade inflammation despite early metabolic syndrome manifestations in children born after in vitro fertilization, *Fertil Steril* 94:1693, 2010.
954. **Miles HL, Hofman PL, Peek J, Harris M, Wilson D, Robinson EM, Gluckman PD, Cutfield WS**, In vitro fertilization improves childhood growth and metabolism, *J Clin Endocrinol Metab* 92:3441, 2007.
955. **Scherrer U, Rimoldi SF, Rexhaj E, Stuber T, Duplain H, Garcin S, de Marchi SF, Nicod P, Germond M, Allemann Y, Sartori C**, Systemic and pulmonary vascular dysfunction in children conceived by assisted reproductive technologies, *Circulation* 125:1890, 2012.
956. **Wagenaar K, van Weissenbruch MM, Knol DL, Cohen-Kettenis PT, Delemarre-van de Waal HA, Huisman J**, Behavior and socioemotional functioning in 9-18-year-old children born after in vitro fertilization, *Fertil Steril* 92:1907, 2009.
957. **Wagenaar K, van Weissenbruch MM, van Leeuwen FE, Cohen-Kettenis PT, Delemarre-van de Waal HA, Schats R, Huisman J**, Self-reported behavioral and socioemotional functioning of 11- to 18-year-old adolescents conceived by in vitro fertilization, *Fertil Steril* 95:611, 2011.
958. **Golombok S, MacCallum F, Goodman E**, The "test-tube" generation: parent-child relationships and the psychological well-being of in vitro fertilization children at adolescence, *Child Dev* 72:599, 2001.
959. **Wagenaar K, van Weissenbruch MM, Knol DL, Cohen-Kettenis PT, Delemarre-van de Waal HA, Huisman J**, Information processing, attention and visual-motor function of adolescents born after in vitro fertilization compared with spontaneous conception, *Hum Reprod* 24:913, 2009.
960. **Levy-Shiff R, Vakil E, Dimitrovsky L, Abramovitz M, Shahar N, Har-Even D, Gross S, Lerman M, Levy I, Sirota L, Fish B**, Medical, cognitive, emotional, and behavioral outcomes in school-age children conceived by in-vitro fertilization, *J Clin Child Psychol* 27:320, 1998.
961. **Knoester M, Helmerhorst FM, Vandenbroucke JP, van der Westerlaken LA, Walther FJ, Veen S**, Cognitive development of singletons born after intracytoplasmic sperm injection compared with in vitro fertilization and natural conception, *Fertil Steril* 90:289, 2008.
962. **Abdel-Mannan O, Sutcliffe A**, I was born following ART: how will I get on at school? *Semin Fetal Neonatal Med* 19:245, 2014.

963. **Hargreave M, Jensen A, Toender A, Andersen KK, Kjaer SK**, Fertility treatment and childhood cancer risk: a systematic meta-analysis, *Fertil Steril* 100:150, 2013.
964. **Williams CL, Bunch KJ, Stiller CA, Murphy MF, Botting BJ, Wallace WH, Davies M, Sutcliffe AG**, Cancer risk among children born after assisted conception, *N Engl J Med* 369:1819, 2013.
965. **Sundh KJ, Henningsen AK, Kallen K, Bergh C, Romundstad LB, Gissler M, Pinborg A, Skjaerven R, Tiitinen A, Vassard D, Lannering B, Wennerholm UB**, Cancer in children and young adults born after assisted reproductive technology: a Nordic cohort study from the Committee of Nordic ART and Safety (CoNARTaS), *Hum Reprod* 29:2050, 2014.
966. **Buster JE, Bustillo M, Thorneycroft IH, Simon JA, Boyers SP, Marshall JR, Louw JA, Seed RW, Seed RG**, Non-surgical transfer of in vivo fertilised donated ova to five infertile women: report of two pregnancies, *Lancet* 2:223, 1983.
967. **Trounson A, Leeton J, Besanko M, Wood C, Conti A**, Pregnancy established in an infertile patient after transfer of a donated embryo fertilised in vitro, *Br Med J (Clin Res Ed)* 286:835, 1983.
968. **Lutjen P, Trounson A, Leeton J, Findlay J, Wood C, Renou P**, The establishment and maintenance of pregnancy using in vitro fertilization and embryo donation in a patient with primary ovarian failure, *Nature* 307:174, 1984.
969. **Sauer MV, Kavic SM**, Oocyte and embryo donation 2006: reviewing two decades of innovation and controversy, *Reprod Biomed Online* 12:153, 2006.
970. **Practice Committee of American Society for Reproductive Medicine; Practice Committee of Society for Assisted Reproductive Technology**, Recommendations for gamete and embryo donation: a committee opinion, *Fertil Steril* 99:47, 2013.
971. **Karnis MF, Zimon AE, Lalwani SI, Timmreck LS, Klipstein S, Reindollar RH**, Risk of death in pregnancy achieved through oocyte donation in patients with Turner syndrome: a national survey, *Fertil Steril* 80:498, 2003.
972. **Practice Committee of American Society for Reproductive Medicine**, Increased maternal cardiovascular mortality associated with pregnancy in women with Turner syndrome, *Fertil Steril* 90:S185, 2008.
973. **Navot D, Scott RT, Droesch K, Veeck LL, Liu HC, Rosenwaks Z**, The window of embryo transfer and the efficiency of human conception in vitro, *Fertil Steril* 55:114, 1991.
974. **Navot D, Bergh PA, Williams M, Garrisi GJ, Guzman I, Sandler B, Fox J, Schreiner-Engel P, Hofmann GE, Grunfeld L**, An insight into early reproductive processes through the in vivo model of ovum donation, *J Clin Endocrinol Metab* 72:408, 1991.
975. **Miles RA, Paulson RJ, Lobo RA, Press MF, Dahmouh L, Sauer MV**, Pharmacokinetics and endometrial tissue levels of progesterone after administration by intramuscular and vaginal routes: a comparative study, *Fertil Steril* 62:485, 1994.
976. **Navot D, Anderson TL, Droesch K, Scott RT, Kreiner D, Rosenwaks Z**, Hormonal manipulation of endometrial maturation, *J Clin Endocrinol Metab* 68:801, 1989.
977. **Li TC, Cooke ID, Warren MA, Goolamallee M, Graham RA, Aplin JD**, Endometrial responses in artificial cycles: a prospective study comparing four different oestrogen dosages, *Br J Obstet Gynaecol* 99:751, 1992.
978. **Krasnow JS, Lessey BA, Naus G, Hall LL, Guzick DS, Berga SL**, Comparison of transdermal versus oral estradiol on endometrial receptivity, *Fertil Steril* 65:332, 1996.
979. **Tourgeman DE, Gentzchein E, Stanczyk FZ, Paulson RJ**, Serum and tissue hormone levels of vaginally and orally administered estradiol, *Am J Obstet Gynecol* 180:1480, 1999.
980. **Rosenwaks Z**, Donor eggs: their application in modern reproductive technologies, *Fertil Steril* 47:895, 1987.
981. **Bourgain C, Devroey P, Van Waesberghe L, Smits J, Van Steirteghem AC**, Effects of natural progesterone on the morphology of the endometrium in patients with primary ovarian failure, *Hum Reprod* 5:537, 1990.
982. **Gonen Y, Casper RF, Jacobson W, Blankier J**, Endometrial thickness and growth during ovarian stimulation: a possible predictor of implantation in in vitro fertilization, *Fertil Steril* 52:446, 1989.

983. **Shapiro H, Cowell C, Casper RF**, The use of vaginal ultrasound for monitoring endometrial preparation in a donor oocyte program, *Fertil Steril* 59: 1055, 1993.
984. **Csapo AI, Pulkkinen MO, Wiest WG**, Effects of luteectomy and progesterone replacement therapy in early pregnant patients, *Am J Obstet Gynecol* 115:759, 1973.
985. **Sauer MV, Paulson RJ**, Oocyte donors: a demographic analysis of women at the University of Southern California, *Hum Reprod* 7:726, 1992.
986. **Mascarenhas M, Sunkara SK, Antonisamy B, Kamath MS**, Higher risk of preterm birth and low birth weight following oocyte donation: a systematic review and meta-analysis, *Eur J Obstet Gynecol Reprod Biol* 218:60, 2017.
987. **Blazquez A, Garcia D, Rodriguez A, Vassena R, Figueras F, Vernaeve V**, Is oocyte donation a risk factor for preeclampsia? A systematic review and meta-analysis, *J Assist Reprod Genet* 33:855, 2016.
988. **Masoudian P, Nasr A, de Nanassy J, Fung-Kee-Fung K, Bainbridge SA, El Demellawy D**, Oocyte donation pregnancies and the risk of preeclampsia or gestational hypertension: a systematic review and metaanalysis, *Am J Obstet Gynecol* 214:328, 2016.

---

# Fertility Preservation

Women requiring gonadotoxic treatment can now choose from one or more fertility preservation options. Similar options are available for women who desire to postpone childbearing due to personal reasons. Egg and embryo freezing are no longer considered experimental and are routinely employed worldwide with good outcomes. The evolving field of ovarian tissue cryopreservation is still considered experimental but appears to be promising with more than 100 babies born using this approach.<sup>1,2,3,4,5</sup> In males, fertility preservation is largely limited to sperm cryopreservation in adults as there are currently no established methods to generate mature sperm from cryopreserved testicular tissues obtained from prepubertal boys. We will therefore focus on fertility preservation in females.





# Malignant Diseases

Annual worldwide new cancer cases are projected to increase by more than 50% in the next two decades (14–21 million from 2012 through 2030), while the overall cancer death rates continue to decline, with a 13% drop in the United States from 2004 through 2013 ([www.cancer.gov](http://www.cancer.gov)). Not surprisingly, the number of cancer survivors continues to increase and has reached nearly 14.5 million in 2014 in the United States, where it is expected to rise to 19 million by 2024. About 9% of new cancer cases are diagnosed during the reproductive age, and, as of January 2016, there are 8 million female cancer survivors in the United States, of which 5% are 15–40 years of age.

Approximately 82,000 prepubertal girls are diagnosed with cancer each year worldwide, of which 5,000 are in the United States.<sup>6</sup> This group's overall 5-year survival that was 82% in 2014 is steadily increasing due to early diagnosis and treatment.<sup>6</sup> The most common cancers in children (0–14 years old) in the United States are leukemia (31%), central nervous system malignancies (21%), and lymphoma (10%).<sup>7</sup> Nowadays, lymphoma and leukemia (in young women) as well as breast cancer (in relatively older women but who are still in their reproductive age) can be cured or enter long remission following an aggressive chemotherapy with or without radiotherapy. These cancers in particular and others (such as sarcomas and pelvic cancers) make up the majority of cancer-related indications for fertility preservation interventions, preferably prior to the administration of the gonadotoxic chemo-radiotherapy. Gonadotoxicity is an adverse effect of chemotherapy (especially alkylating agents) and pelvic radiotherapy. These directly affect the oocytes and granulosa cells and therefore may lead to a complete irreversible ovarian failure (i.e., iatrogenic menopause). Although chemo- or radiotoxicity is type and dose dependent, the extent of ovarian damage and whether it is reversible or not can only be estimated rather than accurately calculated. To date, there is a lack of consensus on what specific doses of chemotherapy or radiotherapy lead to premature ovarian insufficiency (POI).<sup>1</sup>

# Nonmalignant Conditions

There are multiple benign conditions that may lead to decreased ovarian reserve and POI (e.g., Turner syndrome, fragile X permutation, family history of POI).<sup>8,9</sup> Alternatively, there are benign conditions that necessitate systemic chemotherapy treatment with its gonadotoxic adverse effects potentially leading to POI<sup>10</sup> (e.g., high-grade systemic lupus erythematosus or bone marrow ablation followed by allogeneic transplantation for benign bone marrow disorders such as aplastic anemia, sickle cell disease, and thalassemia). Additionally, nonmalignant conditions such as severe endometriosis have a profound effect on fertility potential owing to disease's natural progression and spread and the surgical interventions for the removal of endometriomas.<sup>11</sup> The resection of bilateral benign ovarian tumors such as teratomas is another example of a surgical intervention that may decrease ovarian reserve. Recurrent ovarian torsion may also be an independent risk factor for POI.

# Fertility Decline Associated with Advanced Age

Age is the most significant threat to female fertility, as oocyte quality declines with age. Today, more and more women are postponing childbearing due to personal reasons such as graduate education, career choices, lack of a partner, or financial considerations.<sup>12</sup> Consequently, the age at which women attempt their first pregnancy is steadily increasing.<sup>10</sup> In the United States, the average age at first pregnancy has increased from 22.5 in 1970 to 25.0 in 2006 and 26.3 in 2014.<sup>13</sup> Furthermore, in many instances, the first pregnancy attempt takes place after the age of 35 when fertility potential may have decreased significantly. In the United States, in 2014, 21.1% of mothers had their first birth at the age of 30–34 years. More strikingly, the same year, 9.1% had their first birth at the age of 35 or later; this was an almost 10-fold increase from 1970 when only 1 out of 100 women would delay their first birth to age 35 or later.<sup>13</sup>

# CRYOPRESERVATION OF EMBRYOS AND OOCYTES

---

Embryo and mature oocyte cryopreservation are the only established effective fertility preservation approaches currently available.

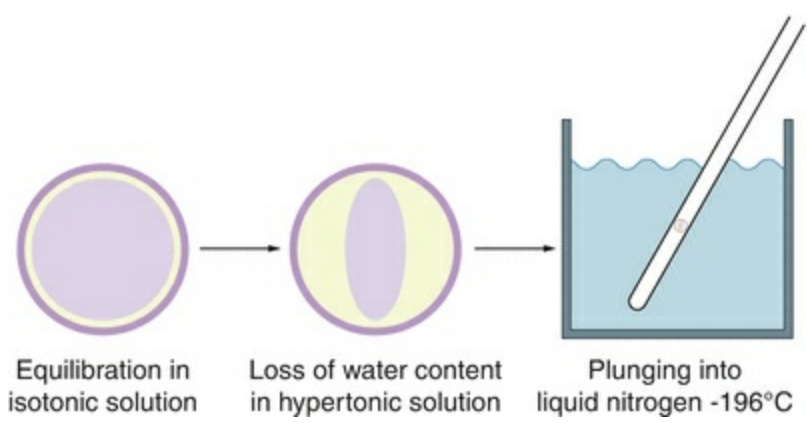
The first report of human pregnancy following embryo cryopreservation<sup>14</sup> occurred only 5 years after the first in vitro fertilization (IVF) live birth,<sup>15</sup> and embryo cryopreservation has now been successfully employed for over than 30 years. Today, the transfer of vitrified (superior to slow freezing) thawed embryos is as effective as the transfer of fresh ones, without a decline in live birth rates.<sup>12</sup>

The making of embryos requires sperm from a male partner or a donor. This approach is therefore not ideal for women who would like to preserve their fertility but currently do not have a male partner and do not wish to use donor sperm. Oocyte cryopreservation, on the other hand, provides reproductive autonomy to women who wish to preserve their fertility.

Following the first report of a pregnancy achieved with cryopreserved oocytes by Chen in 1986,<sup>16</sup> progress in the field of oocyte cryopreservation has been challenging. Mature (MII) oocytes are among the largest cells in the human body and contain the delicate meiotic spindle. As oocyte cytoplasm contains a high proportion of water in comparison to other cells, damage due to ice crystal formation was an initial hurdle to oocyte viability after frozen storage. Protocols that include dehydration of oocytes before and/or during the cooling procedure reduced ice crystal formation and led to improved clinical outcomes. Cryopreservation of mature oocytes has also been shown to cause hardening of the zona pellucida, resulting in adverse effects upon fertilization.<sup>17</sup> Significant improvement in the fertilization of cryopreserved oocytes was achieved with the use of intracytoplasmic sperm injection (ICSI),<sup>18,19</sup> possibly due to the circumvention of the effects of zona hardening.

Research in the field of oocyte cryopreservation has been in part fueled by legal limitations imposed on embryo cryopreservation in a number of countries. As an example, Italian law had restrictions regarding the cryopreservation of excess embryos but allowed egg freezing.<sup>20</sup> The vitrification technique (already described in the 1990s) of oocytes as an alternative to slow freezing reduced damage to internal structures and led to improved success rates (**Figure 29.1**).<sup>21,22,23,24</sup> Embryo<sup>12</sup> and oocyte<sup>25</sup> cryopreservation (preferably by vitrification) have now become efficient treatment modalities for women with infertility.<sup>26</sup> Additionally, in a similar fashion to embryo cryopreservation, the live birth rate from cryopreserved versus fresh oocytes is now

considered comparable.<sup>27</sup> Indeed, oocyte vitrification yields remarkable cumulative live birth rates of 60.5% among healthy women who are 35 years old or younger.<sup>28</sup> Women with cancer, however, are expected to have a lower live birth rate likely due to lower oocyte quality caused by the disease.<sup>29</sup> It is also important to note that prepubertal ovaries may not respond to medical stimulation and therefore will not yield mature oocytes available for freezing or fertilization. Therefore, in prepubertal girls, the only available fertility preservation option is ovarian tissue freezing, which is described in detail below (Table 29.1).<sup>30,31</sup>



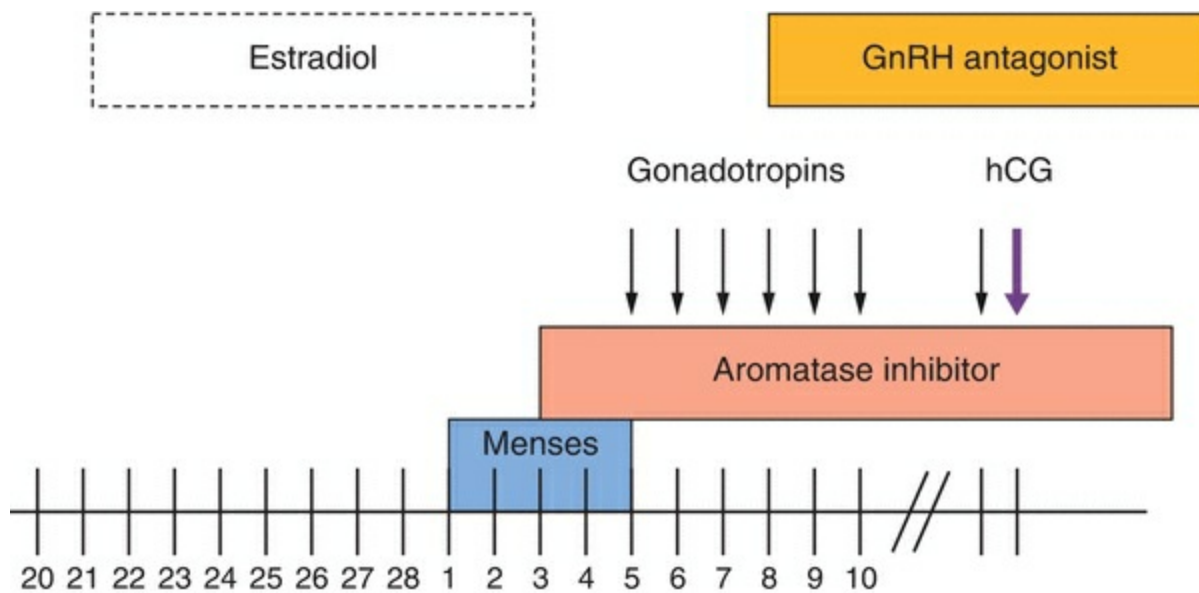
**FIGURE 29.1**

**TABLE 29.1 Advantages and Disadvantages of Embryo, Oocyte, and Ovarian Tissue Cryopreservation**

	Embryo Cryopreservation	Oocyte Cryopreservation	Ovarian Tissue Cryopreservation
Sperm is required	+	-	-
Shared ownership	+	-	-
Delays chemotherapy	+	+	-
Can be used in prepuberty	-	-	+
Effect on endocrine function (at the time of procedure)	-	-	-
Requires ovarian stimulation	+	+	-
Considered experimental	-	-	+
Live births reported	+	+	+
Resumption of endocrine function potential	-	-	+ <sup>a</sup>
Requires surgery	-	-	+
Risk of reseeding cancer	-	-	+

<sup>a</sup>Ovarian tissue harvesting, cryopreservation, and autotransplantation are the only way allowing regaining of endocrine function following gonado-ablative chemo- and/or radiotherapy.

When planning embryo or egg cryopreservation, several factors should be taken into consideration: (1) Age. The younger the woman is at the time of oocyte retrieval and egg/embryo freezing, the higher the live birth rate.<sup>12,28,32</sup> Therefore, women should be encouraged to engage in fertility preservation at a young age, if possible, especially for cases of elective fertility postponement. Another consideration related to age is that prepubertal ovaries are not responsive to gonadotropins due to the absence of ovarian receptors to gonadotropins. Prepubertal cancer patients therefore cannot benefit from fertility preservation techniques that require ovarian stimulation. (2) Delay in cancer treatment. Oocyte and embryo cryopreservation require controlled ovarian hyperstimulation, delaying the administration of chemotherapy by a minimum of 10–12 days. This delay should be acceptable to the oncology team and not jeopardize cancer treatment outcome. Importantly, the delay might be much longer, depending on where the patient is in her menstrual cycle, if a new cycle is awaited for stimulation. However, random-start approaches to ovarian hyperstimulation are equally effective, and such delays are not necessary.<sup>33</sup> (3) Hormone sensitivity of malignancies. Low estradiol levels during ovarian stimulation are considered safer in the setting of malignancies sensitive to estrogens. The ovarian stimulation protocol should therefore be tailored to the steroid hormone sensitivity of the cancer. For example, in the case of estrogen receptor–positive breast cancer, controlled ovarian hyperstimulation with agents that block estrogen production given in conjugation with gonadotropins result in low peak estradiol levels.<sup>34</sup> One option is to start stimulation with an aromatase inhibitor on the second or third day of the menstrual cycle followed by addition of daily follicle-stimulating hormone (FSH) (**Figure 29.2**). The aromatase inhibitor is continued until the day of ovulation trigger and even later if serum estrogen levels are more than 250 pg/mL. using a combination of aromatase inhibitor and FSH for ovarian stimulation seems to yield a comparable number of mature oocytes with only a modest increase in serum estradiol.<sup>35</sup>



**FIGURE 29.2**

# OVARIAN TISSUE CRYOPRESERVATION

---

Ovarian tissue cryopreservation is a unique approach to fertility preservation as it is the only option that is suitable for prepubertal girls. In addition, ovarian tissue extraction does not require prior ovarian stimulation, allowing cancer treatments to begin immediately.

Ovarian tissue cryopreservation and transplantation have been studied in animals for more than 60 years.<sup>36</sup> The first human ovarian transplantation with cryopreserved ovarian tissue was performed in 1999 by Kutluk Oktay.<sup>37</sup> In 2004, the first live human birth from frozen ovarian tissue was reported.<sup>38</sup> Studies in pre- and postpubertal women indicate that autotransplantation of frozen-thawed ovarian tissue is useful for the restoration of endocrine function before and after puberty.<sup>39,40,41</sup> Furthermore, ovarian endocrine activity can be restored in more than 95% of cases.<sup>1</sup>

Although promising, at the time of writing this chapter, this approach was still considered experimental. Given the experimental state of frozen-thawed ovarian tissue transplantation, a significant portion of the literature reporting live births has been provided via case reports.<sup>37,42,43,44</sup> To date, at least 130 live births have been reported globally following the transplantation of cryopreserved ovarian tissue with pregnancies achieved in 1/4 to 1/3 of cases.<sup>45,46,47,48,49</sup>

Live births following cryopreservation of prepubertal ovarian tissue have not yet been described. However, in 2015, Demeestere et al.<sup>44</sup> reported the first live birth following autotransplantation of ovarian tissue extracted before the onset of menarche (during puberty).



# Whole Ovary Cryopreservation

The ovarian cortex harbors the eggs. In most centers worldwide, ovarian cortical tissue is extracted rather than the whole ovary. However, tissue ischemia with loss of follicles remains a common problem after ovarian tissue autotransplantation. Whole ovary autotransplantation may overcome this problem by the reanastomosis of the transplanted vascular pedicle.<sup>5</sup> The disadvantages include possible reseeding of malignancy, technical difficulties with vascular reanastomosis, and greater risk for cryoinjury during the freezing process of a relatively large tissue volume. Additionally, whole ovary freezing may be challenging in humans given the difficulty with adequate diffusion of cryoprotective agents.<sup>5</sup>

Martinez-Madrid et al.<sup>50</sup> succeeded in slow freezing a whole ovary with its vascular pedicle and demonstrated 75% survival of follicles after thawing. In 2008, Silber et al.<sup>51</sup> demonstrated a successful pregnancy in monozygotic twins after fresh whole ovary transplantation. Although healthy offspring have been demonstrated after frozen-thawed whole ovary transplantation in sheep, to date, no human live births have been reported.

# Ovarian Tissue Freezing Techniques and Transplantation Locations

Independent of the freezing technique, cryoinjury may occur during cooling and warming, thereby compromising cell or tissue viability.<sup>52,53</sup> Cryopreservation of ovarian tissue can be performed using one of two established techniques: slow freezing or rapid freezing (vitrification). The slow-freezing method has already resulted in dozens of live births worldwide, whereas vitrified tissue has only led to a few reported live births to date.<sup>2,54,55,56</sup> However, the clinical outcomes of tissue vitrification are not inferior to those of the conventional slow-freezing technique.<sup>57</sup> Therefore, owing to its overall simplicity, the vitrification method might become more popular in clinical practice, as happened for vitrification of oocytes.

The “physiologic” transplantation of frozen-thawed ovarian cortical fragments is orthotopic transplantation, into the remaining ovary, the ovarian fossa, or the broad ligament. Orthotopic transplantation provides the ability to achieve a natural pregnancy without the requirement for IVF. In 2000, Oktay and colleagues<sup>58</sup> reported the first laparoscopic orthotopic transplantation with ovarian tissue placed into the pelvic peritoneum. Subsequently, the first pregnancies resulting in live births after frozen-thawed orthotopic transplantation of ovarian tissue were reported by Donnez et al.<sup>38</sup> and Meirow et al.<sup>59</sup> in 2004 and 2005, respectively. Donnez and colleagues grafted ovarian tissue fragments onto preexisting ovarian tissue.<sup>38</sup> The findings by Donnez and colleagues were promising; however, questions later arose regarding whether the fertilized oocyte had ovulated from the grafted tissue versus the preexisting ovarian tissue.<sup>60</sup> Nonetheless, there are several case reports of live births after transplantation preceded by bilateral oophorectomy, confirming that following orthotopic transplantation, frozen-thawed ovarian cortical ovarian tissue may regain its endocrine function as well as its fertility potential.

Heterotopic transplantation (into the subcutaneous space of the forearm, subcutaneous tissue of the abdomen, anterior wall of the abdomen, just beneath the peritoneum, or in the rectus muscle) is advantageous in cases of severe pelvic adhesions, distorted pelvic anatomy, and poor pelvic vasculature due to previous irradiation. Heterotopic transplantation can be done by a less invasive surgical approach, which does not require general anesthesia thereby creating a more patient-friendly and cost-effective option.<sup>61</sup> However, heterotopic transplantation may produce lower quality oocytes and embryos when compared to the orthotopic approach.<sup>61</sup> These results are likely linked to the less favorable conditions of heterotopic sites in regard to temperature, pressure, reduced paracrine factors, and suboptimal blood supply. To date,

a small number of spontaneous live births after heterotopic transplantation of frozen-thawed ovarian tissue have been reported.<sup>62,63</sup> Importantly, while restoration of ovarian function has been reported for both approaches, live births in women with prior bilateral oophorectomy has only been documented from orthotopic transplantations<sup>64,65</sup> until the report by Stern et al. in 2013, where frozen-thawed ovarian tissue was transplanted to the anterior abdominal wall. Subsequent ovarian stimulation and transabdominal ultrasound-guided oocyte retrieval from the grafts resulted in two oocytes that were fertilized by ICSI. Two embryos were transferred and resulted in a twin pregnancy.<sup>66,67</sup> This report provides evidence that cryopreservation preserves follicular development, and that standard ovarian function and pregnancy can occur from a “heterotopic” transplantation site.

## **In Vitro Follicle Maturation**

An alternative to orthotopic or heterotopic transplantation of frozen-thawed ovarian cortical fragments would be to mature follicles in vitro, especially primordial follicles, which constitute the largest pool of follicles stored in the ovary. This approach would also allow the patient avoid potential reseeding of cancer cells that might have metastasized to the ovarian tissue. However, in vitro maturation (IVM) of immature follicles has proven to be extremely challenging.

More than two decades ago, John Eppig reported a two-step culture protocol that allowed the production of oocytes competent enough to undergo maturation, fertilization, and development to live offspring from primordial follicles of newborn mice.<sup>68</sup> The first step was organ culture of intact newborn ovaries, and the second step was isolation and culture of oocyte-granulosa cell complexes isolated from preantral follicles that developed in the organ-cultured ovaries. Unfortunately, the frequency of successful preimplantation development was very low, and only one live offspring (0.5% of embryos transferred) was produced. Thus, the conditions for oocyte development were not optimal, and the significance of the single birth was questioned. Eppig then conducted studies on factors affecting the development of mouse oocytes in vitro<sup>69,70</sup> and developed a revised two-step protocol that achieved improved developmental competence of oocytes grown in vitro from primordial follicles producing 59 living offspring from in vitro grown oocytes,<sup>71</sup> although the efficiency remained low. Importantly, to address the low efficiency, Eppig used newborn mice, taking advantage of the large wave of folliculogenesis that occurs in mice soon after birth (and prior to sexual maturation). The physiology of this first cohort of follicles is less well defined, and the extent of the findings’ applicability to mature animals remains to be determined.

Most recently, Evelyn Telfer in Edinburgh reported that she was able to develop

mature oocytes from human ovarian cortical strips using a four-step approach.<sup>72</sup> It is noteworthy that it is difficult to establish whether the mature human oocytes generated by Telfer were from primordial follicles or later stages. Moreover, the developmental potential of these eggs remains to be tested. In sum, patients should be informed that an efficient method of generating mature oocytes in vitro from cryopreserved ovarian cortical tissue does not yet exist.

# Combination of Ovarian Tissue Cryopreservation with Other Assisted Reproductive Technologies

Preservation of fertility has proven to be very successful using the established techniques of oocyte and embryo vitrification. This begs the question: would combination of ovarian tissue freezing with assisted reproductive technologies further improve fertility? Is it possible to achieve better fertility preservation outcomes following ovarian tissue cryopreservation by harnessing the efficiency of assisted reproductive technologies?

With the integration of the yet experimental *in vitro* activation (IVA) following ovarian tissue freezing, Kawamura et al.<sup>54,55</sup> have recently shown that women with primary ovarian insufficiency (POI) can have live births following the activation of immature follicles from ovarian tissue formerly considered menopausal. The IVA protocol includes mechanical fragmentation of ovarian tissue to disrupt Hippo signaling and the incubation of ovarian tissue with AKT-stimulating drugs, both of which stimulate the growth of resting follicles.<sup>73,74,75</sup> This approach could potentially be combined with ovarian tissue cryopreservation to activate the resting follicles from vitrified menopausal ovarian tissue *in vitro*, to reach maturity *in vivo*, resulting in sufficient endocrine function, and to produce live births. However, while the idea is promising, uncertainty remains regarding potential negative effects of the drugs involved on oocyte quality. In addition, in interpreting successful live births following IVA in patients with POI, one must also consider the 5% spontaneous pregnancy rate in women with confirmed POI.<sup>76</sup>

The IVM of human oocytes can accompany procedures that involve ovarian tissue cryopreservation. In 2014, Prasath and colleagues<sup>77</sup> reported the first live birth from an immature oocyte that was aspirated *ex vivo* from an extracted ovarian tissue, matured and fertilized *in vitro*. This patient had undergone bilateral oophorectomy for ovarian cancer. Both of her ovaries were found to have cancer cells, and, therefore, ovarian tissue autotransplantation would not be an acceptable option using current technology.

In order to maximize their fertility potential, cancer patients with malignancies insensitive to gonadotropins or estrogen may undergo short ovarian stimulation and egg retrieval before the extraction of ovarian tissue for cryopreservation and the initiation of chemotherapy. Hourvitz and colleagues<sup>78</sup> reviewed the records in their institution and concluded that oocyte aspiration just prior to ovarian tissue cryobanking yielded more oocytes, with a better maturation rate than oocytes retrieved from *ex vivo* ovarian tissue. The combination of ovarian tissue stimulation, egg retrieval, and tissue

cryopreservation has the ability to optimize the endocrine function and fertility potential.

The recent advancements in the field of reproductive technology raise the question: what combination of procedures/techniques might offer the best chance of success for our patients? Certainly, there are a number of promising ideas and more research is needed.

# Menopause and Premature Ovarian Failure in the Era of Tissue Cryopreservation

Even a “radical procedure,” such as unilateral oophorectomy, only marginally affects fertility and the onset of menopause. In a large study, Lass et al.<sup>79</sup> compared IVF treatment outcomes between women who had unilateral oophorectomy and women who had both of their ovaries. Although the oophorectomy group required more ampoules of human menopausal gonadotropin, a longer induction period, and produced fewer oocytes, there was no difference between the pregnancy rates (per oocyte retrieved) between the groups. More recent studies found that women with one ovary entered menopause about a year earlier than women with two ovaries.<sup>80,81</sup> Anderson et al.<sup>82</sup> summarized the current data on menopause and concluded that “...normal women will experience little if any effect on fertility and age of menopause by having ovarian tissue removed when young.”

What if menopause and its related complications could be physiologically delayed? Although the primary goal of ovarian cryopreservation is fertility preservation, transplantation of frozen-thawed ovarian tissue could serve as a physiologic solution to prevent osteoporosis and other menopause-related disorders. Andersen and Kristensen<sup>82</sup> have presented a thought-provoking commentary addressing this question. As noted before, the authors propose that excision of ovarian tissue will advance menopause marginally, but it will not reduce natural fertility. If the tissue is autotransplanted at perimenopausal period, sufficient circulating concentrations of sex steroids may be maintained for years and may potentially delay postmenopausal symptoms for even decades.

Ovarian tissue, with its enormous resting follicle pool, can be cryopreserved in youth and used for multiple purposes in the future. Assuming that natural ovarian hormone production is not harmful regarding breast cancer risk (a theory that has yet to be tested),<sup>83,84</sup> a potential physiologic approach to postpone menopause is readily available: during the perimenopausal period, in cases where a patient wishes to simply delay menopause but is not interested in conception, a minimally invasive subcutaneous transplantation of ovarian cortical strips could be performed. In order to preserve the endocrine function, once the transplant is depleted of functioning follicles, another cryopreserved ovarian cortical strip (or strips) could be transplanted. This approach could be implemented with today’s technology and theoretically has the potential to obviate menopausal symptoms.

# Potential Complications Resulting from Tissue Transplantation

Posttransplantation ischemia is likely responsible for follicular loss. Revascularization after transplantation may take up to 5 days in humans.<sup>85</sup> Research identifying methods to promote angiogenesis will aid in increasing reproductive potential by decreasing ischemia and follicular loss in the transplanted tissue. A live birth following ovarian tissue transplantation utilizing a human decellularized extracellular tissue matrix as a scaffold has been reported.<sup>86</sup> This kind of scaffold is thought to aid in the grafted tissue revascularization and, therefore, improve its function and survival; however, such an effect remains to be experimentally established.

Reimplantation of malignant cells together with the grafted ovarian tissue remains a serious concern. The concept of an artificial ovary may be useful in cases in which malignant cells are suspected to be in the harvested ovarian tissue. Selective transplantation and maturation of healthy follicles in an artificial ovary or grafting material could reduce or eliminate the possibility of reintroducing malignant cells to a patient who has been cured and wishes to conceive. Such approaches have been successfully applied in the mouse using designer biomaterial grafts and retrievable hydrogels.<sup>87,88</sup>



# MEDICAL MANAGEMENT OF OVARIAN PROTECTION

---

Gonadotropin-releasing hormone (GnRH) agonists have a potential benefit in decreasing ovarian tissue damage while exposed to gonadotoxic chemotherapy agents.<sup>89</sup> While the mechanism of protective action remains unclear, several theories have been proposed: (1) Inhibition of FSH-dependent accelerated follicular demise. In the adult ovary, ovarian reserve is primarily made up of primordial follicles that constitute about 90% of the total follicular pool.<sup>90</sup> These follicles are at resting stage and contain oocytes arrested at the prophase of first meiotic division. Primordial follicles initiate follicle growth through an unknown mechanism, which is FSH independent.<sup>91,92</sup> FSH receptors are not expressed in primordial or primary follicles, but the expression is uniformly present in as early as secondary (preantral) follicles with three to four granulosa layers. It has been hypothesized that the gonadotoxic chemotherapy induces an accelerated rate of follicular demise due to low estrogen and inhibin levels resulting in supraphysiologic FSH secretion.<sup>93</sup> According to this theory, high FSH levels accelerate the rate of preantral follicle recruitment to enter the unidirectional process of maturation, resulting in their further exposure to gonadotoxic effects of chemotherapy, and in an accelerated follicular demise. The administration of GnRH agonists could interrupt this vicious cycle by inducing pituitary desensitization, preventing the increase in FSH concentrations despite low inhibin and estrogen levels.<sup>93</sup> However, as discussed above, primordial follicles constitute the great majority of follicular reserve in adult ovary and do not express FSH receptors. Therefore, the molecular basis for this theory is weak. (2) Decrease in utero-ovarian perfusion. Continuous exposure to a GnRH agonist leads to decreased levels of FSH and LH that result in hypoestrogenic state. Hypoestrogenic state decreases utero-ovarian perfusion,<sup>94,95</sup> which in turn brings to lower total cumulative exposure of the ovaries to the circulating chemotherapeutic agents.<sup>93</sup> (3) GnRH agonist's direct action in the ovary. In addition to its classical releasing action at the pituitary level, GnRH seems to act on extrapituitary sites to regulate various reproductive functions. In the rat ovary, specific high affinity GnRH receptors have been identified in granulosa and theca cells. These binding sites mediate the inhibitory effects of GnRH and its agonists on gonadotropin-stimulated estrogen, progesterin, and androgen biosynthesis. At the granulosa cell level, GnRH treatment decreases aromatase activity as well as the biosynthesis of pregnenolone and progesterone via inhibition of cholesterol side-chain cleavage and 3-beta-hydroxysteroid dehydrogenase enzymes.<sup>96</sup> In addition, in vitro studies suggested that GnRH agonists may decrease chemotherapy-induced granulosa cell damage by interacting directly with GnRH receptors expressed on the granulosa cells' membrane,<sup>97</sup>

while others failed to show an increase in cAMP or activation of ERK or p38 signaling in cultured granulosa cells in response to GnRH or its agonists.<sup>98</sup>

Regardless of these theories, evidence supporting a strong benefit from GnRH agonist use is still lacking, although a mild effect seems to be likely. Recent meta-analyses suggest that GnRH agonists may be effective in protecting ovarian function during chemotherapy in lymphoma<sup>99</sup> and breast cancer<sup>100</sup> patients. Additionally, another meta-analysis shows that GnRH agonists are effective in reducing amenorrhea rates following chemotherapy, and that pregnancy rate was higher in the GnRH agonist arms.<sup>101</sup> On the other hand, a recent randomized trial shows no benefit in preserving endocrine function nor fertility potential<sup>102</sup> as well as other studies providing conflicting data regarding the benefit of GnRH agonists in regard to recovering endocrine function.<sup>103,104</sup> Despite unclear mechanism of protective action and low effectiveness, given the low cost and risk associated with a GnRH agonist cotreatment, its use remains at individual physician's discretion. However, it is important to note that GnRH agonist administration should not be used as a substitute for proven fertility preservation techniques.

# FUTURE PROSPECTS

---

The general field of tissue cryopreservation is evolving and is likely to provide additional achievements in the near future; research in this field is fueled in part by advances in angiogenesis and biomechanics of tissue engineering.

The concept of an artificial ovary may be useful in cases in which malignant cells are suspected to be in the harvested ovarian tissue. Animal studies have shown that isolated follicles and ovarian cells in a biodegradable scaffold can be successfully grafted.<sup>105,106</sup> Selective implantation and maturation of “healthy” follicles in an artificial ovary could reduce or eliminate the possibility of reintroducing malignant cells to a patient who has been cured from cancer and wishes to conceive. An additional approach could be the cryopreservation of follicles. Cryopreservation and in vitro culturing of isolated human primordial follicles is now available.<sup>107</sup> Using a follicular isolation technique, a predetermined number of follicles, sufficient for a desired endocrine function, could be transplanted at a given time. When the levels of sex hormones drop below a desired threshold, the transplantation of additional follicles could be performed. Further development in follicle isolation techniques and artificial ovary substrates may result in a cancer-free source of follicles that could last longer and be safer than pieces of ovarian cortex.

Another important area of interest is the minimization of follicular loss due to posttransplantation ischemia. One approach is the promotion of neovascularization at ovarian transplantation sites, using proangiogenic growth factors.<sup>108,109</sup> Additional approaches could be the inhibition of apoptosis, proliferation of ovarian stromal cells with the administration of Sphingosine-1-Phosphate,<sup>41,110</sup> or even introducing bone marrow stem cells to help stimulate follicle development.<sup>111</sup> While oocyte and embryo cryopreservation are established techniques in fertility preservation, this is still a rapidly evolving field with many new options on the horizon.

# REFERENCES

1. **Donnez J, Dolmans MM**, Fertility preservation in women, *N Engl J Med* 377:1657, 2017.
2. **Salama M, Woodruff TK**, New advances in ovarian autotransplantation to restore fertility in cancer patients, *Cancer Metastasis Rev* 34:807, 2015.
3. **Donnez J, Dolmans MM, Pellicer A**, et al., Restoration of ovarian activity and pregnancy after transplantation of cryopreserved ovarian tissue: a review of 60 cases of reimplantation, *Fertil Steril* 99:1503, 2013.
4. **Imbert R, Moffa F, Tsepelidis S**, et al., Safety and usefulness of cryopreservation of ovarian tissue to preserve fertility: a 12-year retrospective analysis, *Hum Reprod* 29:1931, 2014.
5. **Donnez J, Jadoul P, Squifflet J**, et al., Ovarian tissue cryopreservation and transplantation in cancer patients, *Best Pract Res Clin Obstet Gynaecol* 24:87, 2010.
6. **Salama M, Isachenko V, Isachenko E, Rahimi G, Mallmann P**, Updates in preserving reproductive potential of prepubertal girls with cancer: systematic review, *Crit Rev Oncol Hematol* 103:10, 2016.
7. **Ward E, DeSantis C, Robbins A, Kohler B, Jemal A**, Childhood and adolescent cancer statistics, 2014, *CA Cancer J Clin* 64:83, 2014.
8. **Caburet S, Zavadakova P, Ben-Neriah Z**, et al., Genome-wide linkage in a highly consanguineous pedigree reveals two novel loci on chromosome 7 for non-syndromic familial Premature Ovarian Failure, *PLoS One* 7:e33412, 2012.
9. **Nelson LM**, Clinical practice. Primary ovarian insufficiency, *N Engl J Med* 360:606, 2009.
10. **Murk W, Seli E**, Fertility preservation as a public health issue: an epidemiological perspective, *Curr Opin Obstet Gynecol* 23:143, 2011.
11. **Raffi F, Metwally M, Amer S**, The impact of excision of ovarian endometrioma on ovarian reserve: a systematic review and meta-analysis, *J Clin Endocrinol Metab* 97:3146, 2012.
12. **Rienzi L, Gracia C, Maggiulli R**, et al., Oocyte, embryo and blastocyst cryopreservation in ART: systematic review and meta-analysis comparing slow-freezing versus vitrification to produce evidence for the development of global guidance, *Hum Reprod Update* 23:139, 2017.
13. **Mathews TJ, Hamilton BE**, Mean age of mothers is on the rise: United States, 2000-2014, *NCHS Data Brief* (232):1, 2016.
14. **Trounson A, Mohr L**, Human pregnancy following cryopreservation, thawing and transfer of an eight-cell embryo, *Nature* 305:707, 1983.
15. **Stephoe PC, Edwards RG**, Birth after the reimplantation of a human embryo, *Lancet* 2:366, 1978.
16. **Chen C**, Pregnancy after human oocyte cryopreservation, *Lancet* 1:884, 1986.
17. **Matson PL, Graefling J, Junk SM, Yovich JL, Edirisinghe WR**, Cryopreservation of oocytes and embryos: use of a mouse model to investigate effects upon zona hardness and formulate treatment strategies in an in-vitro fertilization programme, *Hum Reprod* 12:1550, 1997.
18. **Porcu E, Fabbri R, Seracchioli R, Ciotti PM, Magrini O, Flamigni C**, Birth of a healthy female after intracytoplasmic sperm injection of cryopreserved human oocytes, *Fertil Steril* 68:724, 1997.
19. **Polak de Fried E, Notrica J, Rubinstein M, Marazzi A, Gomez Gonzalez M**, Pregnancy after human donor oocyte cryopreservation and thawing in association with intracytoplasmic sperm injection in a patient with ovarian failure, *Fertil Steril* 69:555, 1998.
20. **Ragni G, Allegra A, Anserini P**, et al., The 2004 Italian legislation regulating assisted reproduction technology: a multicentre survey on the results of IVF cycles, *Hum Reprod* 20:2224, 2005.
21. **Antinori M, Licata E, Dani G, Cerusico F, Versaci C, Antinori S**, Cryotop vitrification of human oocytes results in high survival rate and healthy deliveries, *Reprod Biomed Online* 14:72, 2007.
22. **Cao YX, Xing Q, Li L**, et al., Comparison of survival and embryonic development in human oocytes cryopreserved by slow-freezing and vitrification, *Fertil Steril* 92:1306, 2009.
23. **Fadini R, Brambillasca F, Renzini MM**, et al., Human oocyte cryopreservation: comparison between slow and ultrarapid methods, *Reprod Biomed Online* 19:171, 2009.

24. **Smith GD, Serafini PC, Fioravanti J**, et al., Prospective randomized comparison of human oocyte cryopreservation with slow-rate freezing or vitrification, *Fertil Steril* 94:2088, 2010.
25. **Cil AP, Seli E**, Current trends and progress in clinical applications of oocyte cryopreservation, *Curr Opin Obstet Gynecol* 25:247, 2013.
26. **Loren AW, Mangu PB, Beck LN**, et al., Fertility preservation for patients with cancer: American Society of Clinical Oncology clinical practice guideline update, *J Clin Oncol* 31:2500, 2013.
27. **Grifo JA, Noyes N**, Delivery rate using cryopreserved oocytes is comparable to conventional in vitro fertilization using fresh oocytes: potential fertility preservation for female cancer patients, *Fertil Steril* 93:391, 2010.
28. **Cobo A, Garcia-Velasco JA, Coello A, Domingo J, Pellicer A, Remohi J**, Oocyte vitrification as an efficient option for elective fertility preservation, *Fertil Steril* 105:755.e8, 2016.
29. **Pellicer A**, Fertility preservation: what is best—oocyte vitrification or tissue freezing? 24th World Congress on Controversies in Obstetrics, Gynecology & Infertility, Amsterdam, Netherlands, 2016.
30. **Wallace WH, Anderson RA, Irvine DS**, Fertility preservation for young patients with cancer: who is at risk and what can be offered? *Lancet Oncol* 6:209, 2005.
31. **Levine JM, Kelvin JF, Quinn GP, Gracia CR**, Infertility in reproductive-age female cancer survivors, *Cancer* 121:1532, 2015.
32. **Cil AP, Bang H, Oktay K**, Age-specific probability of live birth with oocyte cryopreservation: an individual patient data meta-analysis, *Fertil Steril* 100:492.e3, 2013.
33. **Cakmak H, Katz A, Cedars MI, Rosen MP**, Effective method for emergency fertility preservation: random-start controlled ovarian stimulation, *Fertil Steril* 100:1673, 2013.
34. **Reddy J, Oktay K**, Ovarian stimulation and fertility preservation with the use of aromatase inhibitors in women with breast cancer, *Fertil Steril* 98: 1363, 2012.
35. **Oktay K, Buyuk EL, Libertella N, Akar M, Rosenwaks Z**, Fertility preservation in breast cancer patients: a prospective controlled comparison of ovarian stimulation with tamoxifen and letrozole for embryo cryopreservation, *J Clin Oncol* 23:4347, 2005.
36. **Parrott DM**, The fertility of mice with orthotopic ovarian grafts derived from frozen tissue, *J Reprod Fertil* 1:230, 1960.
37. **Oktay K, Karlikaya GG, Aydin BA**, Ovarian cryopreservation and transplantation: basic aspects, *Mol Cell Endocrinol* 169:105, 2000.
38. **Donnez J, Dolmans MM, Demylle D**, et al., Live birth after orthotopic transplantation of cryopreserved ovarian tissue, *Lancet* 364:1405, 2004.
39. **Silber SJ**, Ovary cryopreservation and transplantation for fertility preservation, *Mol Hum Reprod* 18:59, 2012.
40. **Kolp LA, Hubayter Z**, Autotransplantation of cryopreserved ovarian tissue: a procedure with promise, risks, and a need for a registry, *Fertil Steril* 95:1879, 2011.
41. **Resetkova N, Hayashi M, Kolp LA, Christianson MS**, Fertility preservation for prepubertal girls: update and current challenges, *Curr Obstet Gynecol Rep* 2:218, 2013.
42. **Ernst E, Bergholdt S, Jorgensen JS, Andersen CY**, The first woman to give birth to two children following transplantation of frozen/thawed ovarian tissue, *Hum Reprod* 25:1280, 2010.
43. **Demeestere I, Simon P, Moffa F, Delbaere A, Englert Y**, Birth of a second healthy girl more than 3 years after cryopreserved ovarian graft, *Hum Reprod* 25:1590, 2010.
44. **Demeestere I, Simon P, Dedeken L**, et al., Live birth after autograft of ovarian tissue cryopreserved during childhood, *Hum Reprod* 30:2107, 2015.
45. **Silber S**, Ovarian tissue cryopreservation and transplantation: scientific implications, *J Assist Reprod Genet* 33:1595, 2016.
46. **Oliver D**, David Oliver: Why shouldn't hospitals challenge inspections? *BMJ* 351:h5320, 2015.
47. **Van der Ven H, Liebenthron J, Beckmann M**, et al., Ninety-five orthotopic transplantations in 74 women of ovarian tissue after cytotoxic treatment in a fertility preservation network: tissue activity, pregnancy and delivery rates, *Hum Reprod* 31:2031, 2016.
48. **Bedaiwy MA, El-Nashar SA, El Saman AM**, et al., Reproductive outcome after transplantation of ovarian

tissue: a systematic review, *Hum Reprod* 23:2709, 2008.

49. **Jensen AK, Macklon KT, Fedder J, Ernst E, Humaidan P, Andersen CY**, 86 successful births and 9 ongoing pregnancies worldwide in women transplanted with frozen-thawed ovarian tissue: focus on birth and perinatal outcome in 40 of these children, *J Assist Reprod Genet* 34:325, 2017.
50. **Martinez-Madrid B, Dolmans MM, Van Langendonck A, Defrere S, Donnez J**, Freeze-thawing intact human ovary with its vascular pedicle with a passive cooling device, *Fertil Steril* 82:1390, 2004.
51. **Silber SJ, Grudzinskas G, Gosden RG**, Successful pregnancy after microsurgical transplantation of an intact ovary, *N Engl J Med* 359:2617, 2008.
52. **Mullen SF, Critser JK**, The science of cryobiology, *Cancer Treat Res* 138:83, 2007.
53. **Karlsson JO, Toner M**, Long-term storage of tissues by cryopreservation: critical issues, *Biomaterials* 17:243, 1996.
54. **Kawamura K, Cheng Y, Suzuki N**, et al., Hippo signaling disruption and Akt stimulation of ovarian follicles for infertility treatment, *Proc Natl Acad Sci U S A* 110:17474, 2013.
55. **Suzuki N, Yoshioka N, Takae S**, et al., Successful fertility preservation following ovarian tissue vitrification in patients with primary ovarian insufficiency, *Hum Reprod* 30:608, 2015.
56. **Kuleshova L, Gianaroli L, Magli C, Ferraretti A, Trounson A**, Birth following vitrification of a small number of human oocytes: case report, *Hum Reprod* 14:3077, 1999.
57. **Amorim CA, Curaba M, Van Langendonck A, Dolmans MM, Donnez J**, Vitrification as an alternative means of cryopreserving ovarian tissue, *Reprod Biomed Online* 23:160, 2011.
58. **Oktay K, Karlikaya G**, Ovarian function after transplantation of frozen, banked autologous ovarian tissue, *N Engl J Med* 342:1919, 2000.
59. **Meirow D, Levron J, Eldar-Geva T**, et al., Pregnancy after transplantation of cryopreserved ovarian tissue in a patient with ovarian failure after chemotherapy, *N Engl J Med* 353:318, 2005.
60. **Sonmezer M, Oktay K**, Orthotopic and heterotopic ovarian tissue transplantation, *Best Pract Res Clin Obstet Gynaecol* 24:113, 2010.
61. Suzuki N, Donnez J, editors. *Gonadal tissue cryopreservation in fertility preservation*. Tokyo: Springer; 2016 Jun 21.
62. **Oktay K**, Spontaneous conceptions and live birth after heterotopic ovarian transplantation: is there a germline stem cell connection? *Hum Reprod* 21:1345, 2006.
63. **Oktay K, Turkuoglu I, Rodriguez-Wallberg KA**, Four spontaneous pregnancies and three live births following subcutaneous transplantation of frozen banked ovarian tissue: what is the explanation? *Fertil Steril* 95:804.e7, 2011.
64. **Demeestere I, Simon P, Emiliani S, Delbaere A, Englert Y**, Orthotopic and heterotopic ovarian tissue transplantation, *Hum Reprod Update* 15:649, 2009.
65. **Donnez J, Dolmans MM**, Transplantation of ovarian tissue, *Best Pract Res Clin Obstet Gynaecol* 28:1188, 2014.
66. **Stern CJ, Gook D, Hale LG**, et al., First reported clinical pregnancy following heterotopic grafting of cryopreserved ovarian tissue in a woman after a bilateral oophorectomy, *Hum Reprod* 28:2996, 2013.
67. **Stern CJ, Gook D, Hale LG**, et al., Delivery of twins following heterotopic grafting of frozen-thawed ovarian tissue, *Hum Reprod* 29:1828, 2014.
68. **Eppig JJ, O'Brien MJ**, Development in vitro of mouse oocytes from primordial follicles, *Biol Reprod* 54:197, 1996.
69. **Eppig JJ, O'Brien MJ, Pendola FL, Watanabe S**, Factors affecting the developmental competence of mouse oocytes grown in vitro: follicle-stimulating hormone and insulin, *Biol Reprod* 59:1445, 1998.
70. **Eppig JJ, Hosoe M, O'Brien MJ, Pendola FM, Requena A, Watanabe S**, Conditions that affect acquisition of developmental competence by mouse oocytes in vitro: FSH, insulin, glucose and ascorbic acid, *Mol Cell Endocrinol* 163:109, 2000.
71. **O'Brien MJ, Pendola JK, Eppig JJ**, A revised protocol for in vitro development of mouse oocytes from primordial follicles dramatically improves their developmental competence, *Biol Reprod* 68:1682, 2003.
72. **McLaughlin M, Albertini DF, Wallace WHB, Anderson RA, Telfer EE**, Metaphase II oocytes from

- human unilaminar follicles grown in a multi-step culture system, *Mol Hum Reprod* 24:135, 2018.
73. **Hsueh AJ, Kawamura K, Cheng Y, Fauser BC**, Intraovarian control of early folliculogenesis, *Endocr Rev* 36:1, 2015.
  74. **Li J, Kawamura K, Cheng Y**, et al., Activation of dormant ovarian follicles to generate mature eggs. *Proc Natl Acad Sci U S A* 107:10280, 2010.
  75. **Cordeiro CN, Christianson MS, Selter JH, Segars JH Jr**, In vitro activation: a possible new frontier for treatment of primary ovarian insufficiency, *Reprod Sci* 23:429, 2016.
  76. **van Kasteren YM, Schoemaker J**, Premature ovarian failure: a systematic review on therapeutic interventions to restore ovarian function and achieve pregnancy, *Hum Reprod Update* 5:483, 1999.
  77. **Prasath EB, Chan ML, Wong WH**, et al., First pregnancy and live birth resulting from cryopreserved embryos obtained from in vitro matured oocytes after oophorectomy in an ovarian cancer patient, *Hum Reprod* 29:276, 2014.
  78. **Hourvitz A, Yerushalmi GM, Maman E**, et al., Combination of ovarian tissue harvesting and immature oocyte collection for fertility preservation increases preservation yield, *Reprod Biomed Online* 31:497, 2015.
  79. **Lass A, Paul M, Margara R, Winston RM**, Women with one ovary have decreased response to GnRHa/HMG ovulation protocol in IVF but the same pregnancy rate as women with two ovaries, *Hum Reprod* 12:298, 1997.
  80. **Bjelland EK, Wilkosz P, Tanbo TG, Eskild A**, Is unilateral oophorectomy associated with age at menopause? A population study (the HUNT2 Survey), *Hum Reprod* 29:835, 2014.
  81. **Yasui T, Hayashi K, Mizunuma H**, et al., Factors associated with premature ovarian failure, early menopause and earlier onset of menopause in Japanese women, *Maturitas* 72:249, 2012.
  82. **Andersen CY, Kristensen SG**, Novel use of the ovarian follicular pool to postpone menopause and delay osteoporosis, *Reprod Biomed Online* 31:128, 2015.
  83. **Lobo RA**, What the future holds for women after menopause: where we have been, where we are, and where we want to go, *Climacteric* 17(Suppl 2):12, 2014.
  84. **Lobo RA, Davis SR, De Villiers TJ**, et al., Prevention of diseases after menopause, *Climacteric* 17:540, 2014.
  85. **Shikanov A, Zhang Z, Xu M**, et al., Fibrin encapsulation and vascular endothelial growth factor delivery promotes ovarian graft survival in mice, *Tissue Eng Part A* 17:3095, 2011.
  86. **Oktay K, Bedoschi G, Pacheco F, Turan V, Emirdar V**, First pregnancies, live birth, and in vitro fertilization outcomes after transplantation of frozen-banked ovarian tissue with a human extracellular matrix scaffold using robot-assisted minimally invasive surgery, *Am J Obstet Gynecol* 214:94.e1, 2016.
  87. **Kniazeva E, Hardy AN, Boukaidi SA, Woodruff TK, Jeruss JS, Shea LD**, Primordial follicle transplantation within designer biomaterial grafts produce live births in a mouse infertility model, *Sci Rep* 5:17709, 2015.
  88. **Rios PD, Kniazeva E, Lee HC**, et al., Retrievable hydrogels for ovarian follicle transplantation and oocyte collection, *Biotechnol Bioeng* 115:2075, 2018.
  89. **Cakmak H, Seli E**, Gonadotropin-releasing hormone agonists, In: Seli E, Agarwal A, eds. *Fertility Preservation*, Springer, New York, 2012, p. 145.
  90. **Oktay K, Nugent D, Newton H, Salha O, Chatterjee P, Gosden RG**, Isolation and characterization of primordial follicles from fresh and cryopreserved human ovarian tissue, *Fertil Steril* 67:481, 1997.
  91. **McNatty KP, Heath DA, Lundy T**, et al., Control of early ovarian follicular development, *J Reprod Fertil Suppl* 54:3, 1999.
  92. **Oktay K, Briggs D, Gosden RG**, Ontogeny of follicle-stimulating hormone receptor gene expression in isolated human ovarian follicles, *J Clin Endocrinol Metab* 82:3748, 1997.
  93. **Blumenfeld Z, von Wolff M**, GnRH-analogues and oral contraceptives for fertility preservation in women during chemotherapy, *Hum Reprod Update* 14:543, 2008.
  94. **Kitajima Y, Endo T, Nagasawa K**, et al., Hyperstimulation and a gonadotropin-releasing hormone agonist modulate ovarian vascular permeability by altering expression of the tight junction protein claudin-5, *Endocrinology* 147:694, 2006.

95. **Saitta A, Altavilla D, Cucinotta D**, et al., Randomized, double-blind, placebo-controlled study on effects of raloxifene and hormone replacement therapy on plasma no concentrations, endothelin-1 levels, and endothelium-dependent vasodilation in postmenopausal women, *Arterioscler Thromb Vasc Biol* 21:1512, 2001.
96. **Hsueh AJ, Schaeffer JM**, Gonadotropin-releasing hormone as a paracrine hormone and neurotransmitter in extra-pituitary sites, *J Steroid Biochem* 23:757, 1985.
97. **Imai A, Sugiyama M, Furui T, Tamaya T, Ohno T**, Direct protection by a gonadotropin-releasing hormone analog from doxorubicin-induced granulosa cell damage, *Gynecol Obstet Invest* 63:102, 2007.
98. **Torrealday S, Lalioti MD, Guzeloglu-Kayisli O, Seli E**, Characterization of the gonadotropin releasing hormone receptor (GnRHR) expression and activity in the female mouse ovary, *Endocrinology* 154:3877, 2013.
99. **Zhang Y, Xiao Z, Wang Y, Luo S, Li X, Li S**, Gonadotropin-releasing hormone for preservation of ovarian function during chemotherapy in lymphoma patients of reproductive age: a summary based on 434 patients, *PLoS One* 8:e80444, 2013.
100. **Lambertini M, Moore HCF, Leonard RCF**, et al., Gonadotropin-releasing hormone agonists during chemotherapy for preservation of ovarian function and fertility in premenopausal patients with early breast cancer: a systematic review and meta-analysis of individual patient-level data, *J Clin Oncol* 36:1981, 2018.
101. **Ben-Aharon I, Gafer-Gvili A, Leibovici L, Stemmer SM**, Pharmacological interventions for fertility preservation during chemotherapy: a systematic review and meta-analysis, *Breast Cancer Res Treat* 122:803, 2010.
102. **Demeestere I, Brice P, Peccatori FA**, et al., No evidence for the benefit of gonadotropin-releasing hormone agonist in preserving ovarian function and fertility in lymphoma survivors treated with chemotherapy: final long-term report of a prospective randomized trial, *J Clin Oncol* 34:2568, 2016.
103. **Bedaiwy MA, Abou-Setta AM, Desai N**, et al., Gonadotropin-releasing hormone analog cotreatment for preservation of ovarian function during gonadotoxic chemotherapy: a systematic review and meta-analysis, *Fertil Steril* 95:906.e1, 2011.
104. **Roness H, Kashi O, Meirou D**, Prevention of chemotherapy-induced ovarian damage, *Fertil Steril* 105:20, 2016.
105. **Vanacker J, Luyckx V, Dolmans MM**, et al., Transplantation of an alginate-matrigel matrix containing isolated ovarian cells: first step in developing a biodegradable scaffold to transplant isolated preantral follicles and ovarian cells, *Biomaterials* 33:6079, 2012.
106. **Luyckx V, Dolmans MM, Vanacker J**, et al., A new step toward the artificial ovary: survival and proliferation of isolated murine follicles after autologous transplantation in a fibrin scaffold, *Fertil Steril* 101:1149, 2014.
107. **Camboni A, Van Langendonck A, Donnez J, Vanacker J, Dolmans MM, Amorim CA**, Alginate beads as a tool to handle, cryopreserve and culture isolated human primordial/primary follicles, *Cryobiology* 67:64, 2013.
108. **Callejo J, Salvador C, Gonzalez-Nunez S**, et al., Live birth in a woman without ovaries after autograft of frozen-thawed ovarian tissue combined with growth factors, *J Ovarian Res* 6:33, 2013.
109. **Abir R, Fisch B, Jessel S, Felz C, Ben-Haroush A, Orvieto R**, Improving posttransplantation survival of human ovarian tissue by treating the host and graft, *Fertil Steril* 95:1205, 2011.
110. **Soleimani R, Heytens E, Oktay K**, Enhancement of neoangiogenesis and follicle survival by sphingosine-1-phosphate in human ovarian tissue xenotransplants, *PLoS One* 6:e19475, 2011.
111. **Herraiz S, Buigues A, Diaz-Garcia C**, et al., Fertility rescue and ovarian follicle growth promotion by bone marrow stem cell infusion, *Fertil Steril* 109:908.e2, 2018.



## Recurrent Early Pregnancy Loss

Spontaneous abortion or miscarriage is defined as the involuntary termination of pregnancy before 20 weeks of gestation (dated from the last menstrual period) or below a fetal weight of 500 g. Losses after 20 weeks are considered stillbirths or premature births and generally have different causes than losses that occur earlier in gestation.

Historically, recurrent pregnancy loss (RPL) or “habitual abortion” was defined as three or more consecutive spontaneous miscarriages. Popular theory during the 1930s and 1940s held that risk for spontaneous miscarriage increased progressively with each successive loss. Calculations based on that assumption by Malpas and later by Eastman suggested that three consecutive miscarriages demonstrated a predisposition to pregnancy loss that raised the risk for spontaneous miscarriage in the next pregnancy to as high as 73–84%.<sup>1,2</sup> In that era, the “control” for numerous studies evaluating the effectiveness of various treatments for recurrent pregnancy loss (hormones, vitamins, psychotherapy) was theoretical rather than real; the observed incidence of miscarriage in treated women was compared to the predicted or expected incidence rather than to the actual incidence observed in untreated or placebo-treated women. Unfortunately, one of the consequences of such flawed study design was the erroneous conclusion that treatments, including diethylstilbestrol (DES), were effective when in fact they were not. Years later, clinical studies based on empiric observations demonstrated that the risk of miscarriage after three previous losses is actually much lower than predicted (30–45%) and varies with the number of previous live births (none, 40–45%; one or more, about 30%).<sup>3,4,5,6</sup>

There is no specific number of miscarriages or firmly established criterion that justifies evaluation for recurrent pregnancy loss or defines the scope of investigation. Decisions must be individualized and consider the female partner’s age, the timing and circumstances surrounding earlier pregnancy losses, elements of the personal and family medical history, and the couple’s level of anxiety. It is estimated that fewer than 5% of women will experience two consecutive pregnancy losses, and only 1% experience three losses or more.<sup>7</sup> Today, recurrent pregnancy loss is usually defined as three or more pregnancy losses (not necessarily consecutive).<sup>8</sup> Most also consider clinical investigation and treatment appropriate in couples with two consecutive spontaneous miscarriages. It is important to remember that self-reported losses by patients may not be accurate. In one study, only 71% of self-reported clinical pregnancy losses were

consistent with hospital records.<sup>9</sup> Therefore, for purpose of determining whether evaluation for RPL is appropriate, clinical pregnancy should be defined by ultrasound documentation or histopathologic examination. Evaluation is especially indicated when any of the following are also present:

- Embryonic heart activity observed before any earlier pregnancy loss.
- Normal karyotype on products of conception from an earlier loss.
- Female partner age over 35 years.
- Infertility.

The vast majority of all early pregnancy losses result from chromosomal abnormalities arising in the egg, the sperm, or during early embryonic development and are random events. Even repeated miscarriages can occur by chance alone, but at least some affected couples have a predisposing factor. Among all the factors that have been implicated, the only undisputed causes of recurrent pregnancy loss are genetic (balanced chromosomal translocation in either partner, maternal age-related increase in prevalence of aneuploid oocytes), anatomic (congenital and acquired uterine abnormalities), or immunologic (the thrombotic complications of antiphospholipid syndrome). **Alloimmunopathology, inherited thrombophilias (factor V Leiden and others), endocrinopathies (thyroid disorders, diabetes, luteal phase deficiency), infections (genital mycoplasmas), and environmental exposures (smoking, heavy alcohol, or caffeine consumption) have been implicated but are not established causes of recurrent pregnancy loss.** Even after a comprehensive evaluation, recurrent pregnancy loss remains unexplained in well more than half of affected couples ([Table 30.1](#)).

### **TABLE 30.1 The Risk of Recurrent Early Pregnancy Loss in Young Women<sup>4,5,6</sup>**

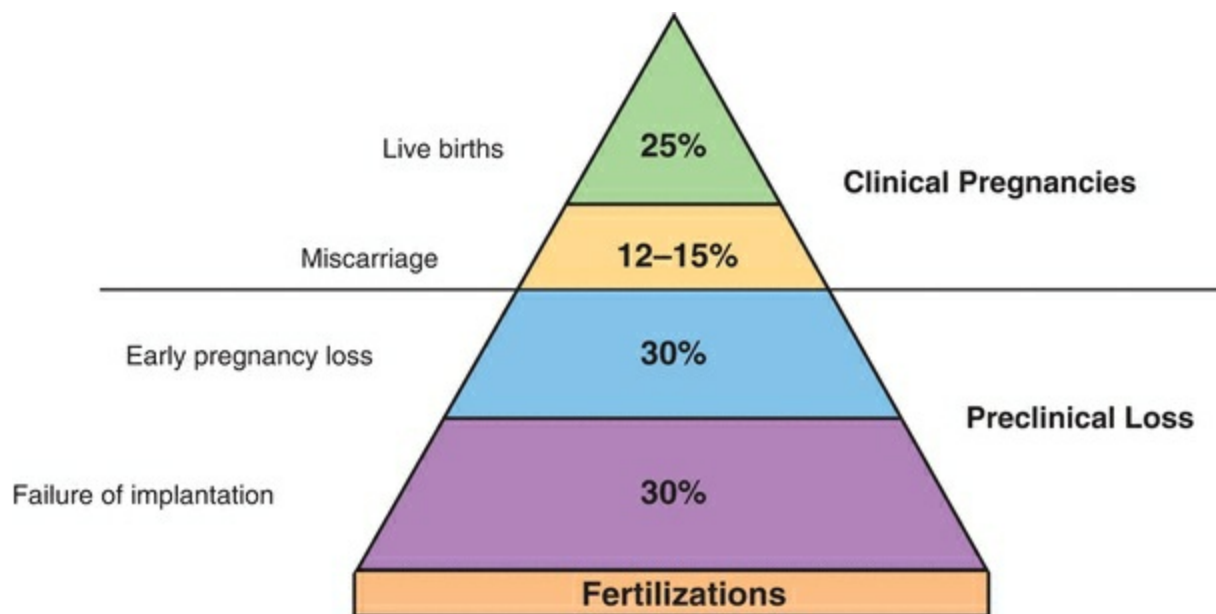
	Number of Prior Miscarriages	% Risk of Miscarriage in Next Pregnancy
Women who have had at least one live-born infant	0	12%
	1	24%
	2	26%
	3	32%
	4	26%
	6	53%
Women who have not had at least one live-born infant	2 or more	40–45%

**For all couples who have suffered recurrent pregnancy loss, education can provide important perspective; most couples welcome the offer of evaluation to identify any predisposing factor. When a likely cause can be defined, specific counseling and treatment can improve the prognosis for a successful pregnancy. When no specific cause can be found, reassurance and encouragement are no less valuable.**

# EPIDEMIOLOGY OF PREGNANCY LOSS

Early pregnancy loss is a very common event, even more so than most couples realize. Almost all chromosomally abnormal conceptions spontaneously abort, most before 10 weeks' gestation, and over 90% of conceptions having a normal karyotype continue.<sup>10,11</sup> Miscarriage may thus be viewed as a natural selection process for quality control. Learning that miscarriage is common, normal, and inevitable in most cases does not heal the emotional wounds left by earlier losses or eliminate the anxiety that affected couples have when contemplating another attempt at pregnancy,<sup>12,13</sup> but an accurate perspective is nonetheless important and often very helpful.

Overall, approximately 12–15% of clinically recognized pregnancies end in spontaneous miscarriage between 4 and 20 weeks of gestation. However, the true early pregnancy loss rate, including both clinically recognized and unrecognized occult early miscarriages, is 2–4 times greater, depending on age. Careful studies in normally cycling healthy young women attempting pregnancy have shown that human chorionic gonadotropin (hCG) can often be detected transiently in the urine of women who are otherwise quite unaware that they had conceived and miscarried.<sup>14,15,16</sup> No less than 30% of all conceptions abort within the first 12 weeks of gestation, and at least half of all losses go unnoticed. The reproductive loss that occurs even before a first missed menses is substantial.<sup>17</sup> Most recognized pregnancy losses occur before 8 weeks of gestation, and relatively few occur after 12 weeks (**Figure 30.1**).<sup>18</sup>



**FIGURE 30.1**

Numerous studies have documented that the risk of spontaneous miscarriage varies with past obstetrical history.<sup>3,18,19,20</sup> In general, women in their first pregnancy, those whose only other pregnancy was electively terminated, and women whose only or last pregnancy was successful have a relatively low risk of spontaneous miscarriage (4–6%). Conversely, women whose only or last pregnancy ended in loss have a higher risk of miscarriage in their next pregnancy (19–24%).<sup>18</sup> Unless there has been a subsequent successful pregnancy, even a single loss increases risk for another spontaneous miscarriage in the next pregnancy. Taken together, available evidence also suggests that miscarriage risk increases with the number of pregnancy losses, but very gradually.<sup>4,5,6</sup> Overall, the risk is still less than 40% after four previous losses and no higher than about 50% even with six or more; risk may be modestly higher for women with recurrent pregnancy loss and no previous live-born children.

Independent of past obstetrical history, the risk of clinically recognized spontaneous miscarriage increases with age. Risk is relatively low before age 30 (7–15%) and only slightly higher for women aged 30–34 (8–21%) but then rises more sharply for ages 35–39 (17–28%) and women age 40 and older (34–52%).<sup>21,22,23,24,25</sup> Among women with a past history of pregnancy losses, advancing age adds to the risk related to previous losses; the miscarriage risk for women over age 40 (52%) is more than twice that for women under age 30 (25%).<sup>6</sup> If both recognized and occult pregnancy losses are considered, total pregnancy wastage in women over age 40 may reach or exceed 75%.<sup>15,25,26</sup>

**In summary, approximately 12–15% of all clinically recognized pregnancies end in miscarriage, but the true incidence of miscarriage, including unrecognized early pregnancy losses, is 2–4 times higher (30–60%). Miscarriage risk increases with the number of previous pregnancy losses but rarely exceeds 40–50%. Risk for pregnancy loss also rises with increasing maternal age, moderately after age 35 and more rapidly after age 40.**

# Prognostic Value of Transvaginal Ultrasound Observations

Careful serial observations during early pregnancy have indicated that the risk for miscarriage decreases as the duration of pregnancy increases. The risk of pregnancy loss falls progressively after observation of a gestational sac (12%) and a yolk sac (8%) and as embryonic crown-rump length increases (>5 mm, 7%; 6–10 mm, 3%; >10 mm, <1%).<sup>27</sup> The observation of embryonic heart activity (by approximately 6 weeks' gestation) is another important developmental milestone and good prognostic indicator because most ill-fated pregnancies fail before then, but its predictive value varies with the past obstetrical history, clinical context, and age. In both normal and infertile asymptomatic young women, the timely appearance of embryonic heart activity decreases the risk of pregnancy loss from the global risk of 12–15% to between 3% and 5%.<sup>28,29</sup> In women with past histories of recurrent pregnancy loss, the miscarriage rate after detection of embryonic heart activity is still 3–5 times higher (15–25%).<sup>30,31</sup> In women with threatened abortions, demonstrable embryonic heart activity is again a good prognostic indicator overall (15% loss rate), but the incidence of subsequent loss is higher when there are other abnormal sonographic findings (slow- or late-appearing heart activity, size/date discrepancies, subchorionic hematoma).<sup>32,33,34,35</sup> Finally, the prognostic value of embryonic heart activity declines with increasing maternal age; whereas the risk for subsequent loss is low (<5%) in women age 35 and under, it is 2–3 times higher (approximately 10%) in women ages 36–39 and increased another threefold (29%) in women age 40 and over.<sup>36</sup>

# GENETIC FACTORS

---

Most spontaneous miscarriages result from chromosomal abnormalities in the embryo or fetus. Numerous studies in which large numbers of abortuses have been cultured and karyotyped have suggested that approximately 50% of all first-trimester pregnancy losses, 30% of second-trimester abortuses, and 3% of stillbirths are chromosomally abnormal.<sup>23,24,37,38,39</sup> However, these studies have very likely underestimated the prevalence of chromosomal abnormalities among abortuses because the data are biased by unrecognized maternal cell contamination and because normal euploid cells (from the mother or abortus) are less likely to fail culture than abnormal cell lines.<sup>40,41,42</sup> **Analyses using newer techniques not dependent on cell culture (comparative genomic hybridization or microarray) and more recent careful cytogenetic studies of early missed abortions suggest that the true incidence of chromosomal abnormalities in miscarried early pregnancies is closer to 75%.<sup>43,44</sup>**

Over 90% of the chromosomal abnormalities observed among abortuses are numerical (aneuploidy, polyploidy); the remainder are split between structural abnormalities (translocations, inversions) and mosaicism.<sup>44,45</sup> Overall, autosomal trisomies are the most common abnormality (usually involving chromosomes 13–16, 21, or 22), followed by monosomy X (45,X) and polyploidies.<sup>23,44,46,47</sup> Among women with history of recurrent pregnancy loss, chromosomally normal (euploid) abortuses are more common, particularly in those age 35 and under.<sup>47,48,49,50</sup> The distribution of chromosomal abnormalities observed among the abortuses of women with recurrent pregnancy loss is otherwise no different from that seen in the general population when stratified by maternal or gestational age.<sup>47</sup> The high incidence of sporadic miscarriage and random chromosomal abnormalities means that some of the pregnancy losses in women with recurrent miscarriages result from chance. The likelihood of a euploid abortus increases with the number of previous miscarriages and after a previous abortion having a normal karyotype.<sup>26,49</sup>

# Parental Chromosomal Abnormalities

There is a very high frequency of sporadic karyotypic abnormalities in products of conception, while the actual incidence of karyotypic abnormalities in the parents is low. Indeed, the overwhelming majority of chromosomally abnormal conceptions result from the chance union of one normal and one aneuploid gamete or from nondisjunction during early embryonic development. However, in 4–8% of couples with recurrent pregnancy loss, one or the other partner harbors a chromosomal abnormality that markedly increases the probability of a chromosomally unbalanced conceptus.<sup>51,52,53,54,55,56</sup> Balanced translocations (reciprocal, Robertsonian) are the most common abnormalities; sex chromosome mosaicism, chromosome inversions, and other structural abnormalities can also be observed.<sup>57,58</sup>

In a balanced reciprocal translocation, pieces of two different autosomes (one from each of two different pairs) are translocated (exchanged). In a balanced Robertsonian translocation, the centromeres of two acrocentric chromosomes (numbers 13, 14, 15, 21, 22) fuse to form a single chromosome consisting of the long arms of the two affected chromosomes; the short arms (containing little or no essential genetic material) are lost. In both cases, the translocation carrier is genetically balanced and phenotypically normal. Unfortunately, when their oogonia or spermatogonia undergo meiosis to yield haploid oocytes or sperm, a large proportion of the gametes end up genetically unbalanced and abnormal, having either a deficiency or an excess of genetic material. Depending on how the chromosomes segregate during meiosis, the gametes may be chromosomally normal (containing only the normal copy of each of the two affected chromosome pairs), abnormal but balanced (containing the translocated member of each of the two affected chromosome pairs), or abnormal and unbalanced (containing two copies or no copies of an affected chromosome or chromosome segment). When such chromosomally unbalanced gametes combine with a normal gamete from an unaffected partner, the conceptus will have a trisomy and/or a monosomy and will almost always abort; an unbalanced conceptus may occasionally survive, but those that do are at high risk for malformations and mental retardation.<sup>59</sup>

Genetic counseling is very important when a structural genetic factor is identified. The probability of a subsequent genetically normal conceptus and live birth depends on the chromosome(s) involved and the type of rearrangement. In theory, one-fourth of the gametes produced by reciprocal translocation carriers should be normal, one-fourth should be abnormal but balanced, and one-half should be abnormal and unbalanced, yielding a 50% probability of a normal pregnancy (normal or balanced conceptus) and a 50% probability of an abnormal pregnancy (abortion or a viable but anomalous fetus), assuming union with a chromosomally normal gamete from the unaffected partner. Similarly, given the three different ways in which a Robertsonian translocation



chromosome and the normal members of the affected chromosome pairs may align and segregate during meiosis, one-sixth of the gametes produced by carriers should be normal, one-sixth should be abnormal but balanced, and the remaining two-thirds should be abnormal and unbalanced, yielding a 33% probability of a normal pregnancy (normal or balanced conceptus) and a 67% probability of an abnormal pregnancy (abortion or a viable but anomalous fetus), again assuming a union with a chromosomally normal gamete from the unaffected partner. However, when a Robertsonian translocation involves both members of a single pair of chromosomes, the carrier will produce no normal gametes because all will have either two copies or no copy of the affected chromosome.

Some reciprocal translocations are predisposed to specific rather than random segregation patterns and may yield a skewed distribution of normal, balanced, and unbalanced gametes.<sup>60,61,62</sup> The probability of a successful pregnancy and the risk of a chromosomally abnormal but viable fetus vary with the specific chromosomes involved and the size and location of the translocated segments.<sup>45,59</sup> Abnormalities of some chromosomes (chromosome 21) are better tolerated than others and risk of an unbalanced but viable conceptus is higher when the exchanged chromosomal segments are small. By their very nature, reciprocal translocations tend to be rather unique, so there is usually no easy way to accurately predict the probability of specific pregnancy outcomes for an individual affected couple. At best, the karyotype of the affected partner can allow one to predict the most likely segregation patterns for a specific translocation and to estimate the risk of unbalanced offspring. When the male partner is the translocation carrier, the distribution of normal, balanced, and unbalanced sperm and the prognosis for successful conception can be more accurately defined.<sup>62</sup> When the female partner is the carrier or the distribution of gametes is otherwise unknown, the couple's own reproductive history (and that of any other similarly affected family member) is the best gauge. One exception is a specific recurring translocation involving chromosomes 11 and 22, t(11;22)(q23;q11), the most common reciprocal translocation in humans; over 100 unrelated affected families have been reported, and the reproductive performance of carriers has been well defined.<sup>63,64,65</sup>

Chromosomal inversions occur less frequently than translocations and may or may not have reproductive implications, depending on their size and location. Pericentric inversions (those that involve the centromere) often have no clinical consequences; a pericentric inversion of chromosome 9, inv(9)(p11q13), is so common (1–1.5% in the general population) that some consider it a normal variant with no importance.<sup>66,67</sup> However, the crossovers and recombinations that can occur with paracentric inversions (those not located at the centromere) frequently result in an excess of genetic material resulting in abortion or an anomalous fetus.<sup>45</sup>

As might be anticipated, the most common reproductive history in translocation carrier couples includes both a normal child and early pregnancy losses (6–7%); other histories involving only spontaneous miscarriages or combinations of malformed children, stillbirths, and abortions are slightly less common (4–5%).<sup>54</sup> The probability of identifying a balanced chromosomal translocation in a couple with three or more previous pregnancy losses is not significantly higher than in those having had only two. In some couples, family history (recurrent pregnancy loss, stillbirths, or birth defects) suggests the possibility of an occult chromosomal abnormality after only one spontaneous miscarriage. Couples with miscarriages interspersed with normal pregnancies and outcomes should be evaluated in the same fashion as couples with consecutive miscarriages.<sup>68</sup>

Balanced chromosomal translocations can be found in either partner, and both must be karyotyped to exclude the possibility.<sup>54</sup> Any balanced translocation so identified may have arisen *de novo* or have been inherited from one of the carrier's own parents. If the translocation was inherited, any of the carrier's siblings and, in turn, their offspring might also be affected.<sup>69</sup> Any pregnancy in an affected couple becomes a candidate for prenatal diagnostic studies, regardless of the mother's age or previous reproductive history.<sup>68</sup> Consequently, counseling of translocation carrier couples with recurrent pregnancy loss should consider karyotyping the carrier's parents and, where appropriate, other potentially affected individuals in the kindred. For minor children who may be carriers, karyotyping is best postponed until they reach an age where they are able to grant informed consent.

It is likely that some couples with recurrent pregnancy loss may harbor a genetic abnormality that predisposes to a higher risk of miscarriage but cannot be detected using standard cytogenetic techniques. Possibilities include isolated gonadal or germ-line mosaicism (including a trisomic cell line) and single-gene defects.<sup>45</sup> The recent advent of genome-wide high-resolution technologies, such as chromosome microarray analysis and next-generation sequencing (NGS), including whole exome sequencing (WES), has opened new possibilities for discovery of genetic changes that are too small to be detected by traditional chromosome analysis.

# Aging and Gamete Aneuploidy

The mechanisms responsible for the age-related increase in the incidence of miscarriage and the use of ovarian reserve tests in the evaluation of reproductive age and prognosis are discussed in detail in [Chapter 25](#). The genetic factors that contribute to the increase in pregnancy wastage associated with reproductive aging and the utility of ovarian reserve testing in women with recurrent pregnancy loss are only summarized briefly here.

Several lines of evidence suggest that age-related instability or degradation of the cellular mechanisms that govern meiotic spindle formation and function results in an increasing incidence of meiotic segregation errors and a rapid rise in the numbers of aneuploid oocytes during the later reproductive years.<sup>70,71,72,73,74,75,76</sup> Prevalence studies indicate the aneuploidy in oocytes is relatively low before age 35 (<10%) but increases abruptly thereafter, reaching nearly 100% after age 45.<sup>70</sup> These observations offer a logical explanation for the overall age-related increase in the incidence of miscarriage and the higher prevalence of aneuploidy among the abortuses of aging women.<sup>21,22,23,24</sup> Indeed, most trisomies observed among abortuses can be traced to maternal meiotic errors and oocyte aneuploidy.<sup>77</sup>

Some women with otherwise unexplained recurrent pregnancy loss have a diminished ovarian reserve (DOR) that may help to explain their poor reproductive performance.<sup>78,79</sup> The prevalence of abnormal ovarian reserve tests in women with unexplained recurrent pregnancy loss is higher than in women with other defined causes of recurrent pregnancy loss<sup>78</sup> and comparable to that observed in the general population of infertile women.<sup>79</sup> Moreover, there is evidence that infertile women with DOR and also unexplained RPL patients with DOR have a higher percentage of aneuploid blastocysts as compared to infertile women with normal ovarian reserve and unexplained RPL patients with normal ovarian reserve, respectively, although ovarian reserve is generally not considered a marker of oocyte quality.<sup>80,81,82</sup> These observations suggest that women at advanced stages of ovarian follicular depletion are at higher risk for miscarriage. While it is still controversial whether this association between DOR and miscarriage is true regardless of age,<sup>82</sup> it appears to be stronger in patients 35 years of age or older and to increase with maternal age.<sup>83</sup> Some women will suffer premature ovarian follicular depletion because they are born with a smaller than normal ovarian follicular pool and are genetically destined to be among the 10% of women who experience an early menopause.<sup>84,85,86,87,88</sup> Women who have had a trisomic abortus reach menopause at an earlier average age.<sup>89</sup> Other women may have their ovarian follicular pool depleted by disease that destroys ovarian tissue or requires its removal. Either way, the end result is the same—accelerated follicular depletion,

declining fertility, and increasing risk for miscarriage begin at an earlier than normal age. Besides offering information that may help to explain recurrent pregnancy loss, ovarian reserve testing may identify young women at increased risk for fetal aneuploidy in subsequent pregnancies who would otherwise not be considered candidates for prenatal diagnostic studies.<sup>90,91,92,93,94</sup> The incidence of Down syndrome is increased in women with elevated serum levels of follicle-stimulating hormone (FSH), regardless of age and regardless of whether the low ovarian reserve the high FSH reveals came about naturally or resulted from ovarian surgery.<sup>90,92,93,94</sup>

The prevalence of skewed X chromosome inactivation, defined as preferential inactivation (more than 90%) of one of the two X chromosomes in female cells, is increased in women with recurrent pregnancy loss,<sup>95,96,97,98,99</sup> although this finding was not confirmed in two studies.<sup>100,101</sup> This observation has prompted speculation that X-linked mutations lethal to the male cause skewed X chromosome inactivation in female carriers and predispose to abortion of male conceptuses and an increased prevalence of female live births.<sup>97,102</sup> However, investigation of this issue has not confirmed the predicted excess of chromosomally normal male abortuses.<sup>98</sup> Observations of an increased prevalence of trisomic abortuses among women with recurrent pregnancy loss and skewed X chromosome inactivation have suggested the alternative hypothesis that X chromosome mutations or X-autosome translocations result in skewed X chromosome inactivation and a smaller than normal ovarian follicular pool or accelerated follicular depletion that predisposes to oocyte aneuploidy and recurrent pregnancy loss.<sup>98,103</sup>

Ill-fated chromosomally abnormal conceptuses can also result from fertilization of a normal euploid oocyte by an aneuploid sperm. The sperm of men whose partners have a history of unexplained recurrent pregnancy loss exhibit a higher prevalence of abnormal morphology, chromosome aneuploidy, DNA fragmentation, and abnormal tests of sperm function such as hypo-osmotic swelling.<sup>104,105,106,107,108,109,110,111</sup> The incidence of sperm aneuploidy rises with paternal age, if only slightly,<sup>60,112</sup> and the incidence of miscarriage in young women with older male partners is higher than in those whose partners are young.<sup>113</sup> Taken together, these observations suggest that poor semen quality, like a low ovarian reserve in women, can predispose to both infertility and early pregnancy loss, two different points on a continuum of reproductive failure having some causes in common. However, sperm aneuploidy rarely rises above approximately 1–2%. Compared to the influence of oocyte aneuploidy on miscarriage risk, chromosomally abnormal sperm have relatively little importance as a predisposing factor in recurrent pregnancy loss.

# Karyotyping the Abortus

Many view karyotyping the products of conception following miscarriage as an unnecessary and expensive luxury. Others consider it crucially important for differentiating couples who are candidates for thorough evaluation from those who are not. Without karyotyping, women who repeatedly miscarry generally are assumed to be losing normal pregnancies when, in fact, most are not. Some have even advocated karyotyping the first or second abortus, reasoning that women who abort chromosomally normal pregnancies should be screened for treatable causes of pregnancy loss sooner rather than later. Conversely, those who miscarry a chromosomally abnormal pregnancy might be spared unnecessary and costly evaluation and empiric treatments.<sup>11</sup>

Unfortunately, the karyotype of an abortus cannot provide information so definitive; a karyotype may be useful but has limitations and pitfalls that must be carefully considered. Most early failed pregnancies lose viability well before onset of clinical symptoms of miscarriage or other recognition of the inevitable loss; products of such conceptions may therefore fail to grow in culture. Tissue specimens passed spontaneously are more likely to fail culture than those obtained by curettage.<sup>47</sup> Newer array-based assessment or NGS can yield more complete information as these techniques are applied directly without the need for viable tissues and cell culture.

A normal abortus karyotype might be interpreted as suggesting that genetic factors are not likely responsible, focusing attention on evaluation for other possible causes of recurrent pregnancy loss.<sup>11</sup> Unfortunately, a normal 46,XX karyotype can also represent maternal cell contamination of the tissue specimen and preferential growth of the normal maternal cell line in culture, particularly when no specific care has been taken to dissect, isolate, and submit only chorionic villi for cell culture.<sup>40,41,42</sup> Results from an embryoscopic and cytogenetic study of early missed abortions challenge directly the notion that a normal karyotype effectively excludes genetic causes for a failed pregnancy. Whereas 75% of the abortuses were chromosomally abnormal, fully two-thirds of the remaining 25% having a normal karyotype (17% of the total) exhibited gross developmental abnormalities as severe as those observed in aneuploid abortuses.<sup>44</sup> These observations strongly suggest that over 90% of all early missed abortions involving a recognizable embryo result from genetic errors and imply that a substantial proportion of failed early pregnancies result from gross genetic flaws in organizational and morphogenic processes not detectable with conventional cytogenetic techniques or even more modern methods (FISH, comparative genomic hybridization). Arguably, pregnancies that fail before any recognizable embryogenesis (empty sacs or “blighted ova”) are even more likely to result from chromosomal abnormalities, the inference being that well more than 90% of all early pregnancy losses can result from genetic causes.

Genome-wide high-resolution technologies, such as chromosome microarray analysis and NGS, including WES are being increasingly used and are bound to uncover more subtle changes underlying some of the currently unexplained losses. The clinical relevance of such higher-resolution platform was demonstrated in an analysis of 755 samples determined to be normal by conventional karyotyping that were reevaluated by NGS. In this series, clinically relevant copy number variants (CNVs) (described as corresponding to postnatal microdeletion and microduplication syndromes, clinically significant phenotypes with reduced penetrance or >5 Mb) were identified in 1.6% of euploid losses,<sup>114</sup> while rare variants of uncertain clinical significance (VUS) were seen in approximately 1–40% of sporadic and recurrent euploid miscarriages.<sup>115</sup> Although the relevance of such identified genetic changes to RPL etiology remains to be determined by functional studies, it is likely that genetic variants are underlying the etiology of at least some of the cases currently categorized as unexplained RPL.

An abnormal abortus karyotype revealing trisomy, monosomy, or polyploidy explains that specific pregnancy loss and suggests it is likely resulted from chance alone and generally has been considered as evidence that the risk for recurrence is not significantly increased.<sup>26,50</sup> Whereas such findings may suggest that no formal evaluation is therefore needed, one must assume that couples with other specific causes for recurrent pregnancy loss have at least the same random chance for conceiving an aneuploid pregnancy as anyone else; they might be overlooked if evaluation is offered only to those having a chromosomally normal abortus. Moreover, an aneuploid abortus might also reflect the influence of advanced maternal age or an otherwise unsuspected DOR, in which case the risk for recurrence in a subsequent pregnancy clearly is increased.<sup>116</sup>

A karyotype of an abortus that demonstrates an unbalanced chromosomal translocation obviously suggests that a parent may be a balanced carrier of the same translocation, a suspicion easily confirmed by performing karyotypes on both partners in affected couples.

The more expensive methods for genetic screening to detect variants associated with miscarriages, FISH and comparative genomic hybridization discussed below, can be applied to couples having recurrent miscarriages. However, these are expensive tests, and although variants and polymorphisms can be detected, the chances of having a healthy child, despite a higher risk of miscarriage, are still high, perhaps as high as non-carrier couples.<sup>117</sup>

# Preimplantation Genetic Diagnosis and Aneuploidy Screening

Preimplantation genetic testing (PGT) describes a number of techniques for preconceptional genetic evaluation of embryos resulting from in vitro fertilization (IVF). PGT can be used to detect numerical chromosomal abnormalities (aneuploidy). In this case, it is called preimplantation genetic testing for aneuploidy (PGT-A, previously called preimplantation genetic screening [PGS]). The terms PGT for monogenic disorders (PGT-M, previously called preimplantation genetic diagnosis [PGD]), and PGT for structural rearrangements (PGT-SR), are used when PGT is used to detect inherited monogenic disorders (such as cystic fibrosis, hemophilia, Duchenne muscular dystrophy), or translocations and inversions, respectively.<sup>118,119,120,121</sup> The technique uses one or more cells that may be obtained at different stages of development. The chromosomal composition of the oocyte may be inferred from that of the extruded polar bodies.<sup>118</sup> One or two blastomeres may be removed from cleavage stage embryos. Biopsy of the trophectoderm can be performed at the blastocyst stage and has become the most commonly used technique. When performing a blastocyst stage embryo biopsy, a laser or a dilute solution of acid Tyrode solution is used to create a small hole in the zonapellucida after oocyte retrieval and fertilization. This allows the developing trophectoderm (TE) to protrude after blastulation, facilitating the biopsy. On day 5 post fertilization, approximately five-to-ten cells are excised from the TE using a glass needle or laser energy, leaving the embryo largely intact and without loss of inner cell mass. After genetic diagnosis, the embryos can be replaced during the same cycle or (most commonly) cryopreserved and transferred in a subsequent cycle.

Comparative genomic hybridization is a technique in which test DNA (extracted from blastomeres) and normal male reference DNA (extracted from lymphocytes) are first amplified, then labeled with different colored fluorochromes (green/red), and simultaneously hybridized to template metaphase chromosomes from normal male lymphocytes; the green/red fluorescence ratio reflects the relative copy number for each chromosome in test DNA compared to the normal reference DNA.<sup>122</sup> Comparative genomic hybridization allows analysis of all 24 chromosomes (X, Y, 22 autosomes) and detection of abnormalities not recognized by more limited analysis with FISH.<sup>123,124</sup> This technique has been applied to the genetic evaluation of fetal losses; the diagnostic yield is improved compared with conventional karyotyping, which is often handicapped by culture failures or maternal contamination.<sup>125,126</sup>

Next-generation sequencing (NGS) and massively parallel or deep sequencing are related terms that describe a DNA sequencing technology that has revolutionized genomic research. Using NGS, an entire human genome can be sequenced within a

single day. In contrast, the previous Sanger sequencing technology, used to decipher the human genome, required over a decade to deliver the final draft. There are a number of different NGS platforms using different sequencing technologies, a detailed discussion of which is beyond the scope of this book. However, all NGS platforms perform high-throughput and high-resolution sequencing of millions of small fragments of DNA in parallel. Bioinformatics analyses are used to piece together these fragments by mapping the individual reads to the human reference genome. When whole genome amplification is used, each of the three billion bases in the human genome is sequenced, which makes it challenging to provide high depth to deliver accurate data and an insight into unexpected DNA variation. Alternatively, targeted genome amplification approaches allow higher number of copies to be obtained for each site, and potentially higher diagnostic accuracy. NGS has gained in popularity due to its increased sensitivity in identifying unbalanced translocations, segmental aneuploidies, and some triploidies.<sup>127,128</sup> This increased sensitivity appears to be clinically relevant. One study reexamined embryos that were diagnosed as euploid by aCGH and resulted in miscarriage and found based on NGS that 31.6% of these miscarriages were from mosaic embryos and 5.2% were from triploid embryos.<sup>127</sup> Another study showed that PGT-A using NGS significantly improves pregnancy outcomes versus PGT-A using aCGH in frozen embryo transfers.<sup>129</sup> Regardless of which technique is employed, PGT-A generally involves the analysis of 5–10 TE cells at blastocyst stage, assuming that those selected accurately represent the entire embryo. Unfortunately, a number of studies have now demonstrated that mosaicism (presence of two or more cell lines with a different chromosome content) is common in early human embryos cultured in vitro.<sup>130,131,132,133,134</sup> Mosaicism arises from mitotic segregation errors occurring after fertilization via a variety of mechanisms, including anaphase lag, mitotic nondisjunction, inadvertent chromosome demolition, and premature cell division before DNA duplication.<sup>135,136,137,138,139,140,141,142,143</sup> Interestingly, unlike aneuploidy of meiotic origin, the incidence of mosaic chromosomal abnormality does not change with advancing years, with approximately 30% of blastocyst-stage embryos affected across all maternal ages.<sup>134</sup> However, as the embryos of older reproductive age women are more likely to have meiotic errors, the percentage of TE biopsies containing only euploid cells declines as a woman ages, falling from 50% for women younger than 35 to 10% of blastocysts for women over 42.<sup>134</sup> The mitotic errors, leading to mosaicism, coupled with the advancing risk of meiotic aneuploidy has clinical implications for in vitro fertilization (IVF) treatments, especially those using PGT-A, because it effects the likelihood of detecting an entirely euploid embryo for transfer.<sup>134</sup> Although its impact on implantation and the developmental potential of embryos is not fully known, evidence from several studies suggests that mosaicism influences the implantation rate, with mosaic embryos resulting in lower clinical pregnancy and live birth compared to



euploid embryos.<sup>144,145</sup> Further basic and clinical research will help to better understand the biology of mosaicism and which mosaicism thresholds are clinically relevant.

Overall, the results of PGT-A studies indicate that even in women younger than 35 years, only 50% of embryos are normal for all of the chromosomes examined (biopsy specimens revealing only euploid cells).<sup>146,147,148,149</sup> Data derived from numerous studies reveal that older women and women with a history of recurrent pregnancy loss produce more aneuploid embryos than younger women and those with normal reproductive histories.<sup>150,151,152,153,154</sup> Transfer of PGT-A-selected embryos has been suggested as a strategy to improve implantation rates and decrease abortion rates in women at higher risk for pregnancy loss.<sup>134,138,146,155,156</sup> The ultimate impact of PGT-A on the live birth rate in older women and in women with history of recurrent pregnancy loss is still controversial, and high quality evidence is lacking. A cost-effectiveness analysis in patients with unexplained recurrent pregnancy loss concluded that IVF with PGT-A was not a cost-effective strategy for increasing live birth compared to expectant management, with IVF/PGT-A strategy having a live birth rate of 53% and a clinical miscarriage rate of 7% versus expectant management having a live birth rate of 67% and clinical miscarriage rate of 24%.<sup>157</sup> A cost/benefit analysis in older women concluded that IVF alone is the most cost-effective option under the age of 40, but over age 40, IVF alone and IVF with PGT are equal in cost.<sup>158</sup> Whereas it may be reasonable to consider PGT-A for indications of advanced maternal age or recurrent pregnancy loss in couples with other specific indications for IVF, the results achieved with PGT-A so far do not justify IVF with PGT-A for all couples with advanced maternal age or history of recurrent pregnancy loss. For couples with recurrent pregnancy loss in whom one partner carries a balanced chromosomal translocation, IVF with PGT-SR and transfer of only normal and balanced embryos can achieve pregnancy rates comparable to those observed in unselected infertile couples with substantially decreased risk of spontaneous miscarriage, although pregnancy rates are inversely proportional to the proportion of abnormal gametes.<sup>159,160,161,162,163,164</sup> When the male partner carries the balanced translocation, sperm FISH analysis can be used to determine the proportion of chromosomally unbalanced sperm and to predict the probability of conceiving a successful pregnancy.<sup>62</sup> Data suggest that when there are numerous good-quality embryos and less than approximately 65% unbalanced sperm, translocation carrier couples have a reasonable probability of success with IVF and PGT, but otherwise not.<sup>62</sup> Sperm FISH analysis could prove valuable to affected couples weighing the options of IVF with PGT and therapeutic insemination with donor sperm. Unfortunately, there is no way to obtain similar information for female balanced translocation carriers; depending on the nature of the translocation and on the reproductive history, some

women who carry a balanced translocation may prefer to apply their available resources to IVF with donor oocytes rather than attempt IVF with PGT.

## **Summary of Key Facts Relating to Genetic Factors**

Overall, 50–75% of spontaneous miscarriages result from numerical chromosomal abnormalities in the embryo or fetus and occur by chance; trisomies are the most common. In approximately 5% of couples with recurrent pregnancy loss, karyotypes will reveal a balanced chromosomal translocation that markedly increases the risk of miscarriage due to the high prevalence of aneuploidy in the gametes of the affected parent. Reproductive aging in women is associated with an increasing risk of miscarriage, which reflects a rising prevalence of oocyte aneuploidy. Ovarian reserve testing in women with unexplained recurrent pregnancy loss can reveal evidence of premature reproductive aging. Karyotype of an abortus can explain the loss (aneuploidy), provide evidence for a chromosomal translocation in a parent (when an unbalanced translocation is observed), or suggest a nongenetic cause (when normal). However, a normal karyotype does not entirely exclude genetic causes for the miscarriage, and a normal female karyotype (46,XX) can result from maternal cell contamination of cultured tissue specimens. IVF with preimplantation genetic testing and selected transfer of euploid embryos is an established treatment for couples with recurrent pregnancy loss when one partner carries a balanced chromosomal translocation. IVF with preimplantation genetic testing for aneuploidy screening for reasons of advanced maternal age or in couples with unexplained recurrent pregnancy loss can increase implantation rates and decrease miscarriage risk, but have not increased live birth rates. Consequently, the associated costs in couples without other specific indications for IVF cannot be justified. The limitations of preimplantation genetic testing are still being characterized, and the full biologic significance of mosaicism on embryo implantation and pregnancy potential remains to be defined.

# ANATOMIC FACTORS

---

The anatomic uterine abnormalities that can predispose to a higher risk of pregnancy loss include congenital malformations, uterine leiomyomas, and intrauterine adhesions. Each has been considered in detail elsewhere as factors that may also adversely affect fertility ([Chapters 3 and 25](#)); discussion here is limited to their importance and management in women with a history of recurrent pregnancy loss.

The principal methods for evaluation of the uterus include traditional hysterosalpingography (HSG), transvaginal ultrasonography, and sonohysterography. Magnetic resonance imaging (MRI) and endoscopy (hysteroscopy and laparoscopy) are generally reserved when necessary for better defining the nature of anomalies identified or suggested by simpler methods. Each method and its limitations, pitfalls, and relative accuracy have been described at length in the context of the infertility evaluation ([Chapter 25](#)). However, their relative value for the evaluation of infertility and recurrent pregnancy loss are somewhat different. HSG has some advantages over ultrasonographic techniques for the evaluation of uterine factors in infertile women because it also provides information about tubal patency that transvaginal ultrasonography and sonohysterography cannot. However, for the evaluation of recurrent pregnancy loss, transvaginal ultrasonography and sonohysterography offer distinct advantages over HSG; both image the external uterine fundal contour and, therefore, better distinguish septate and bicornuate uteri,<sup>165,166,167</sup> and both are generally easier to perform and better tolerated than HSG. Compared to HSG, sonohysterography has greater sensitivity and specificity for detection of intracavitary mass lesions (submucous myomas, endometrial polyps) and similar efficacy for diagnosis of intrauterine adhesions.<sup>168,169,170,171,172,173</sup> Three-dimensional transvaginal ultrasonography, with and without saline contrast, can provide high-definition images comparable to those generated with MRI.<sup>174,175</sup> As in women with infertility, endoscopic methods can usually be reserved for excision of cavitary mass lesions or intrauterine septa identified by simpler methods.

# Congenital Uterine Malformations

Developmental uterine anomalies have long been associated with pregnancy loss and obstetric complications. The reported prevalence of uterine malformations in women with recurrent pregnancy loss has varied widely with differences in diagnostic methods and criteria.<sup>176,177,178</sup> The best available data suggest that the prevalence of major uterine anomalies (excluding arcuate uteri) in the general population is approximately 2% and about 3 times greater (6–7%) in women with history of recurrent pregnancy loss, supporting the notion that uterine malformations may indeed be the proximate cause for miscarriages in a small proportion of women with recurrent pregnancy loss.<sup>176,179,180,181,182</sup> Pregnancy losses with uterine congenital abnormalities usually occur later in pregnancy in the second trimester; however, the presence of an uterine anomaly after repeated early losses deserves consideration of surgical repair.<sup>183,184</sup> The pathogenesis of pregnancy wastage in women with congenital uterine malformations is uncertain but generally has been attributed to a reduced intrauterine volume, endometrial dysfunction or poor vascular supply.<sup>185</sup>

A unicornuate uterus results from failure of development of one müllerian duct. Pregnancy outcomes in women with unicornuate uteri are generally poor; approximately half of all recognized pregnancies fail.<sup>186</sup> Most unicornuate uteri are associated with a noncommunicating contralateral uterine horn, some of which have a functional cavity and should be removed to reduce risk for ectopic pregnancy, even if not otherwise necessary (pain, mass, endometriosis).<sup>187</sup> Since approximately 40% of unicornuate uteri are associated with an ipsilateral renal agenesis, further evaluation with an intravenous pyelogram or renal sonogram is also indicated.<sup>187</sup> No surgical procedure can enlarge the unicornuate uterus. Anecdotal reports of successful pregnancies after cervical cerclage are numerous, but the efficacy of cerclage in women with unicornuate uteri has not been carefully studied. **Available evidence suggests that most pregnancies in women with unicornuate uteri are best managed expectantly with cervical cerclage reserved for those with previous second-trimester pregnancy losses or evidence of progressive cervical shortening.**<sup>186</sup>

Uterine didelphys results from complete failure of fusion of the müllerian ducts and normal differentiation of each to form a cervix and hemiuterus. The reproductive outcomes of women with uterine didelphys are slightly better than those of women with unicornuate uteri, possibly because of improved collateral blood supply between the two horns. Nevertheless, approximately 40% of pregnancies in women with uterine didelphys end in spontaneous miscarriage.<sup>186</sup> Failure of the entire müllerian duct to fuse can create two distinct cervixes and two upper hemivaginas; the lower portion of the vagina comes from the urogenital sinus and results in a single lower vagina. Failure of

one hemivagina to fuse with the urogenital sinus results in a transverse vaginal septum that may accumulate menstrual blood as a unilateral hematocolpos. In general, the only surgery indicated in women with uterine didelphys is the removal of an obstructing vaginal septum (75% prevalence).<sup>188</sup> **Unification procedures are usually unnecessary and complicated but can rarely benefit some women with numerous miscarriages or preivable births. When surgery is performed, the recommended technique unifies the two fundi and leaves the two cervixes intact.**<sup>189</sup>

A bicornuate uterus results from incomplete fusion of the müllerian ducts at the level of the fundus, creating two separate uterine cavities with a common lower segment and a single cervix; externally, the uterus has a midline cleft with a depth that varies with the severity of the fusion anomaly. Data from collected series of women with bicornuate uteri reveal miscarriage and overall fetal loss rates of approximately 30% and 40%, respectively.<sup>186</sup> Preterm delivery risks decrease as the size of the common lower uterine cavity increases.<sup>190</sup> **Although the benefits of unification procedures have not been systematically evaluated, surgery generally is considered unnecessary and best reserved for those with a well-established history of otherwise unexplained recurrent pregnancy loss or preivable births.**<sup>186</sup> The Strassman abdominal metroplasty is the surgical procedure of choice, and comparisons between pregnancy outcomes before and after unification suggest that surgery can benefit carefully selected women.<sup>191,192</sup> The incidence of cervical incompetence associated with congenital uterine anomalies is reportedly highest for those having a bicornuate uterus, and there is evidence from case series that cervical cerclage can improve fetal survival rates.<sup>193,194</sup>

A septate uterus results from incomplete resorption of the medial septum separating the two otherwise normally fused hemiuteri. Septum resorption normally occurs only after urologic development is completed; the prevalence of urinary tract anomalies, therefore, is not increased in women with septate uteri. The septate uterus is by far the most common uterine developmental anomaly, accounting for 80–90% of all major malformations in both women with recurrent pregnancy loss (3.5% prevalence) and in the general population.<sup>165,180,182,195</sup> It is also the malformation most highly associated with poor pregnancy outcomes.<sup>165,196</sup> Data from numerous case series indicate that the miscarriage rate associated with septate uteri is approximately 65%.<sup>186</sup> Uterine septa associated with recurrent pregnancy loss are not broader or longer than those observed in women with normal reproductive histories. However, the size of the unaffected cavity (bounded by the leading edge of the septum above and the internal cervical os below) is smaller in women with recurrent pregnancy loss,<sup>176</sup> an observation lending credence to the hypothesis that implantation on a poorly vascularized septum predisposes to pregnancy loss.<sup>197,198,199</sup> Although uterine septa are not always associated with a poor

pregnancy outcome, their discovery in women with recurrent pregnancy loss provides an indication for surgical correction. **Hysteroscopic septoplasty is a relatively brief and straightforward outpatient endoscopic procedure associated with low morbidity and dramatically improved postoperative pregnancy outcomes (80% term delivery, 5% preterm delivery, 15% pregnancy loss).**<sup>165,186</sup> Hysteroscopic septoplasty can be performed using microscissors, any of a variety of electrosurgical instruments, or laser, and excellent results can be achieved with all methods.<sup>165</sup> With few exceptions, only incision rather than excision is required because the septum typically retracts, leaving little if any residual. The procedure usually is complete when both tubal ostia can be viewed at the same time. It is useful to remember that an arcuate uterus is generally regarded as a normal variant and that residual septa measuring less than 1 cm in size have no adverse effect on pregnancy outcome.<sup>200</sup>

Nearly 70% of women exposed to DES in utero have a developmental uterine abnormality.<sup>201</sup> The T-shaped uterine cavity is the single most common malformation; others include a hypoplastic uterus, constriction rings, and irregular intrauterine filling defects. Although the use of DES in pregnancy was banned in 1971 because of an observed association with vaginal clear cell adenocarcinoma and most exposed women are now beyond their reproductive years,<sup>202</sup> affected women are still occasionally encountered. In utero DES-exposed women are at increased risk of adverse pregnancy outcomes, including a twofold higher risk of spontaneous miscarriage (approximately 24%) and a dramatic ninefold higher risk of ectopic pregnancy.<sup>203</sup> Structural changes in cervical collagen content may predispose affected women to cervical incompetence, and data from nonrandomized clinical trials suggest cerclage warrants serious consideration in women with history of second-trimester loss or preterm delivery.<sup>204,205</sup>

# Uterine Leiomyomas

There is no substantial evidence implicating uterine myomas as a cause of recurrent pregnancy loss. What evidence does exist derives from case series comparing reproductive outcomes before and after myomectomy.<sup>206,207,208</sup> All of the mechanisms proposed to explain how myomas might predispose to recurrent pregnancy loss relate to the consequences of poor regional blood flow, abnormal vasculature, and inadequate decidual cell response.<sup>209,210,211,212</sup> Numerous studies have examined the effect of uterine fibroids on fertility (Chapters 3 and 25), but none has specifically examined the effect of myomas on pregnancy outcome in **fertile** women. The best available data come from a series of studies designed to examine the effect of uterine myomas on outcomes achieved with IVF in infertile women.<sup>213</sup> On balance, these data suggest that miscarriage and pregnancy outcomes, like pregnancy and implantation rates, are adversely affected by submucous myomas, but not by subserosal myomas under 5–7 cm in size.<sup>214,215,216,217,218</sup> Evidence regarding the impact of intramural myomas on fertility and miscarriage is less substantial but nevertheless points to lower clinical pregnancy rates, implantation rates, and ongoing pregnancy/live birth rates and significantly higher miscarriage rates.<sup>218</sup> Even if intramural fibroids do indeed decrease fertility, evidence is scarce whether their removal will reverse the process and normalize fertility or miscarriage rates or even be beneficial to the patient. Consequently, management recommendations for women with recurrent pregnancy loss and uterine myomas are comparable to those for infertile women with uterine myomas.

In general, when submucous myomas are single and small, the likely benefits of hysteroscopic myomectomy outweigh the few associated risks.<sup>219,220,221,222,223</sup> When submucous myomas are multiple or large, hysteroscopic myomectomy is more technically challenging and has greater risks, including sterility resulting from severe postoperative intrauterine adhesions; however, this may be the best option for the patient; GnRH therapies may reduce fibroids to a manageable size prior to surgical intervention. When submucous myomas extend deeply into the myometrium, treatment options include subtotal hysteroscopic myomectomy and abdominal myomectomy. When myomas have definite but limited impact on the uterine cavity, the decision to delay or to proceed with surgical treatment may vary, depending on age, reproductive history, size and location of myomas, and the complexity of any other treatments required. **When myomas do not encroach on or distort the uterine cavity, surgery is not indicated in the absence of other specific symptoms attributable to myomas that demand treatment in and of themselves.**

# Intrauterine Adhesions (Asherman Syndrome)

Recurrent pregnancy loss is one possible result of intrauterine adhesions, but menstrual disorders (hypomenorrhea, amenorrhea, dysmenorrhea) and infertility are the more common clinical presentations.<sup>224,225</sup> Any insult severe enough to remove or destroy endometrium can cause intrauterine adhesions, and the gravid uterus seems particularly susceptible to injury.<sup>226,227</sup> Considering that pregnancy loss is among the most common indications for uterine curettage, intrauterine adhesions can first result from and then become a contributing cause of recurrent pregnancy loss. Mechanisms by which intrauterine adhesions can cause recurrent pregnancy loss include a decreased functional intrauterine volume and endometrial fibrosis and inflammation that can predispose to placental insufficiency.<sup>192</sup> The pregnancy outcomes of women with intrauterine adhesions are generally poor (40–80% ending in spontaneous miscarriage and approximately 25% in preterm delivery) and much improved after adhesiolysis (50–90% ending in term delivery, 7–23% ending in miscarriage); the prognosis generally correlates with the severity of disease.<sup>225,226,228,229,230,231</sup>

Hysteroscopy provides the means to confirm a diagnosis of intrauterine adhesions suggested by sonohysterography or HSG and is also the method of choice for treatment, being both safer and more effective than blind curettage. The hysteroscopic appearance of adhesions of varying severity, techniques for lysis, operative risks, and adjuvant therapies are described in detail in [Chapter 25](#).



# **Summary of Key Facts Relating to Anatomic Factors**

**Congenital and acquired uterine abnormalities predispose to an increased risk of pregnancy loss and can be identified by sonohysterography or traditional HSG; magnetic resonance imaging or three-dimensional ultrasound may be required to accurately differentiate septate and bicornuate uteri. The septate uterus is the most common müllerian anomaly, the one most closely correlated with pregnancy loss, and the malformation most easily and successfully corrected; hysteroscopic septoplasty is indicated in women with recurrent pregnancy loss and having a septate uterus. Abdominal metroplasty procedures are rarely indicated for women with a uterus didelphys or a bicornuate uterus. Cervical cerclage may help to improve pregnancy outcomes in women with bicornuate uteri and in those with a unicornuate uterus or a uterus didelphys who have a history of previable delivery or exhibit progressive cervical shortening during early pregnancy. The prevalence of urinary tract abnormalities is increased in women having a unicornuate or bicornuate uterus or a uterus didelphys, but not in those having a septate uterus. Uterine leiomyomas are often identified in women with recurrent pregnancy loss, but only submucous myomas and intramural fibroids that clearly encroach upon or displace the uterine cavity are relevant. Intrauterine adhesions are an uncommon but established cause of recurrent miscarriage; pregnancy outcomes are much improved after hysteroscopic lysis.**

# IMMUNOLOGIC FACTORS

---

Both autoimmune and alloimmune mechanisms have been implicated as causes of recurrent pregnancy loss. Autoimmune disorders involve an immune response directed against a specific part of the host or self; those that have been linked to recurrent pregnancy loss include certain classic autoimmune diseases like systemic lupus erythematosus and the antiphospholipid syndrome. Alloimmune disorders involve an abnormal maternal immune response to fetal or placental antigens; possibilities include maternal cytotoxic antibodies, absent maternal blocking antibodies, and disturbances in natural killer (NK) cell function and distribution.

# Autoimmune Disorders

Systemic lupus erythematosus has long been associated with pregnancy loss. Data from a number of case series suggest that the risk for loss is approximately 20%, all excess risk being attributable to losses occurring during the second and third trimester of pregnancy.<sup>232</sup> Early spontaneous miscarriages are no more common in women with systemic lupus than in the general population, but the incidence of later losses (6%) is 2–4 times higher.<sup>233</sup> Almost all fetal deaths that occur in women with systemic lupus are associated with antiphospholipid antibodies; they are the most sensitive indicator of fetal distress or death.<sup>234,235,236</sup> Active disease at conception, onset of systemic lupus erythematosus during pregnancy, and renal disease also increase the risk for pregnancy loss.<sup>233</sup> Careful monitoring and timely interventions can improve pregnancy outcomes.<sup>237,238</sup> Treatment aimed at preventing pregnancy loss in women with systemic lupus and antiphospholipid antibodies is similar to that for women with antiphospholipid syndrome, which is discussed later. In general, women with active systemic lupus erythematosus should be advised to delay conception until remission can be established, those with moderate renal insufficiency must be advised of the increased risk for pregnancy loss, and women with severe renal insufficiency should be encouraged to avoid pregnancy; even successful pregnancies are at increased risk for preeclampsia and preterm delivery.<sup>233</sup>

**Antiphospholipid syndrome** is an autoimmune disorder having specific clinical and laboratory features; diagnosis requires at least one of each.<sup>239,240</sup> The clinical diagnostic criteria include thromboembolic events (arterial, venous, small vessel) and pregnancy loss (three or more consecutive losses at less than 10 weeks' gestation, a fetal death after 10 weeks, premature birth at less than 34 weeks associated with severe preeclampsia or placental insufficiency). There are also three laboratory diagnostic criteria. One is the lupus anticoagulant, revealed by delayed clotting in phospholipid-dependent coagulation tests (activated partial thromboplastin time, kaolin clotting time, dilute Russell's viper venom time), corrected by addition of excess phospholipid but not by platelet-poor plasma.<sup>241</sup> The second is the demonstration of moderate to high levels of anticardiolipin antibodies (IgG or IgM); low levels may be observed in 3–5% of normal individuals and are of uncertain significance.<sup>242</sup> More recently, a high titer of antibodies to  $\beta$ 2-glycoprotein 1 is also considered sufficient to establish the diagnosis.<sup>243</sup> Abnormal laboratory test results must be observed on at least two separate occasions at least 12 weeks apart.

**The international consensus definition for the diagnosis of antiphospholipid syndrome is noted in Table 30.2.<sup>244</sup> The diagnosis requires one of the clinical criteria and one of the laboratory findings.**

## TABLE 30.2 Diagnosis of Antiphospholipid Syndrome

<b>Clinical criteria</b>	<ul style="list-style-type: none"><li>• Vascular thrombosis</li><li>• Pregnancy morbidity:<ul style="list-style-type: none"><li>○ One or more losses after the 10th week of a morphologically normal fetus</li><li>○ One or more premature births of a normal neonate before the 34th week because of preeclampsia or eclampsia or placental insufficiency</li><li>○ Three or more unexplained consecutive early miscarriages</li></ul></li></ul>
<b>Laboratory tests</b>	<ul style="list-style-type: none"><li>• Lupus anticoagulant present on two or more occasions at least 12 weeks apart</li><li>• Anticardiolipin antibody of IgG or IgM isotype in medium to high titer on two or more occasions at least 12 weeks apart</li><li>• Anti-<math>\beta</math>2-glycoprotein 1 antibody of IgG or IgM isotype in 99th percentile titer on two or more occasions at least 12 weeks apart</li></ul>

Derived from Miyakis S, Lockshin MD, Atsumi T, Branch DW, Brey RL, Cervera R, Derksen RH, De Groot PG, Koike T, Meroni PL, Rebar G, Schoenfeld Y, Tincani A, Vlachoyiannopoulos PG, Krilis SA, International consensus statement on an update of the classification criteria for definite antiphospholipid syndrome (APS), *J Thromb Haemost* 4:295, 2006.244

Although the prevalence of antiphospholipid syndrome among all women with recurrent pregnancy loss is quite low (3–5%),<sup>245</sup> the disorder is nonetheless a potentially treatable cause of recurrent pregnancy loss. **Tests for the detection of a lupus anticoagulant and antiphospholipid antibodies specified above are minimally invasive, relatively inexpensive, and, therefore, justified in the evaluation of most if not all women with recurrent pregnancy loss.**<sup>233</sup> Tests to detect other antibodies associated with this syndrome (antiannexin, antiphosphatidylserine, antiphosphatidylethanolamine, antibodies to plasminogen and plasminogen activator, and others) have been advocated in the evaluation of women with recurrent pregnancy loss but provide no important additional information.<sup>233</sup> Assays for antiphospholipid antibodies other than lupus anticoagulant, anticardiolipin, and anti- $\beta$ 2-glycoprotein 1 have not been standardized or extensively studied, their clinical relevance (independent of lupus anticoagulant, anticardiolipin, and anti- $\beta$ 2-glycoprotein 1) has not been established, and many apparently healthy women have low levels of circulating antiphospholipid antibodies.<sup>233,241,242,246</sup>

The evidence implicating antiphospholipid antibodies as a predisposing factor in recurrent pregnancy loss is largely circumstantial but nonetheless fairly compelling. A small but still important number of women with recurrent pregnancy loss have circulating antiphospholipid antibodies.<sup>233</sup> Women with antiphospholipid antibodies identified by screening in early gestation have an increased rate of pregnancy loss.<sup>247,248</sup> They also exhibit an unusually high rate of loss in subsequent pregnancies, even when treated.<sup>249,250,251,252</sup> Additional evidence comes from animal models; passive

immunization with IgG antiphospholipid antibodies from women with antiphospholipid syndrome induces abortion in mice. Antiphospholipid syndrome can be found in association with systemic lupus erythematosus or in women with no other evidence of autoimmune disease.<sup>253,254,255</sup>

In contrast to observations in most series of women with recurrent pregnancy loss, between one-third and three-fourths of pregnancy losses related to antiphospholipid syndrome are fetal deaths (after 10 weeks' gestation).<sup>249,256,257</sup> Frequently, fetal death is preceded by observations of poor fetal growth, oligohydramnios, heart rate abnormalities and preeclampsia or eclampsia, all of which might reflect hypoxemia resulting from placental insufficiency.

Several mechanisms have been proposed to explain the clinical manifestations associated with aPL. Evidence indicates that antiphospholipid antibodies are directed against platelets (promoting adhesion) and the vascular endothelium (where alterations in prostacyclin/thromboxane metabolism cause vasoconstriction),<sup>258,259</sup> both mechanisms predisposing to thrombosis. Circulating antiphospholipid antibodies have also been linked to reduced levels of an antithrombotic phospholipid-binding protein on the surface of trophoblasts and endothelial cells (annexin V).<sup>260,261</sup> Clustering of annexin A5 on phospholipid surface results in displacement of clotting factor Va, creating an anticoagulant shield. Not surprisingly, spiral arteriolar vasculopathy can often be demonstrated or, in severe cases, placental infarctions.<sup>262</sup> The binding of antiphospholipid antibodies to trophoblast cells reduces proliferation and invasion, as well as the release of hCG. In decidual tissue, antiphospholipid antibodies reduce the production of vascular endothelial growth factor (VEGF) and matrix metalloproteinases and the formation of new blood vessels.<sup>263</sup>

Thrombosis in the placental circulation is a plausible mechanism for late pregnancy loss in women with antiphospholipid syndrome, but does not explain losses that occur before 10 weeks' gestation when maternal arterial connections with the intervillous space become established. Recent evidence suggests that another mechanism relating to abnormalities of early trophoblast invasion may be involved, in both early and late pregnancy losses.<sup>264</sup> In normal early pregnancy, extravillous trophoblast invades the decidual vessels, first forming plugs that later dissociate as the trophoblast migrates along the maternal arterial circulation converting the uteroplacental vessels into a low-resistance circuit.<sup>265</sup> Defective trophoblast invasion of the uteroplacental arteries has been well described in association with later pregnancy complications, including preeclampsia and fetal growth restriction. Antiphospholipid antibodies on the surface of the trophoblast or maternal vessel walls may inhibit endovascular trophoblast invasion, preventing formation of plugs that normally serve to limit intervillous blood flow and prevent pressure-induced or oxidative damage to the trophoblast during early placental

development. Alternatively, antiphospholipid antibodies may damage the trophoblast directly. Either way, abnormal endovascular trophoblast invasion could explain early miscarriages in women with antiphospholipid syndrome and, in less severe cases, the development of later pregnancy complications relating to uteroplacental vascular insufficiency.<sup>264</sup> The pathophysiology involves inflammation at the maternal-fetal interface, preventing normal trophoblast development and function.<sup>266</sup> Activation of the complement cascade has attracted much attention in recent years in the context of inflammation and obstetrical antiphospholipid syndrome. Inflammation is now believed to be at the core of the pathogenesis of this syndrome, and tissue injury is speculated to be the result of complement-mediated inflammatory reaction in addition to thrombosis. Findings from animal models of aPL-induced pregnancy loss and increased injury-induced thrombosis argue that complement factor C3 and C5 are essential proximal mediators of tissue injury to the developing fetal-placental unit.<sup>267</sup>

Treatments for antiphospholipid syndrome have included antiplatelet agents (aspirin), anticoagulants (heparin), and immunosuppressive therapies (prednisone, intravenous immunoglobulins). Whereas most studies have found heparin therapy more effective than aspirin and combined treatment with aspirin and heparin superior to treatment with either alone,<sup>248,251,268,270,270</sup> two trials found that heparin did not further improve the outcomes achieved with aspirin.<sup>271,272</sup> A typical combined treatment regimen includes aspirin (75–85 mg/day), beginning with attempts at conception, and unfractionated heparin (UFH) (5,000–10,000 subcutaneous twice daily), beginning at first indication of pregnancy. Live birth rates for women with antiphospholipid syndrome who receive combined treatment with aspirin and UFH during pregnancy (70–80%) are much improved over those observed in women who receive aspirin treatment or no treatment (20–40%).<sup>268,269,273,274,275</sup> However, treatment does not eliminate the high risk for pregnancy complications (preterm labor, premature rupture of membranes, intrauterine growth restriction and fetal demise, preeclampsia, and placental abruption) and poses additional risks for the mother (gastric bleeding, osteopenia).<sup>269,273</sup> Randomized clinical trials have demonstrated that aspirin and heparin treatment of women with two or more consecutive pregnancy losses in the **absence** of evidence for the antiphospholipid syndrome (unexplained recurrent miscarriages) yields no benefit.<sup>276,277</sup>

Low molecular weight heparin (LMWH) offers a number of advantages over UFH. It has an increased antithrombotic ratio (preventing abnormal clotting with fewer bleeding side effects) and is associated with a lower incidence of both thrombocytopenia and osteopenia; the relatively longer half-life of LMWH also permits less frequent dosing and requires less frequent monitoring, both improving compliance.<sup>278</sup> Although experience with LMWH in pregnancy is relatively limited,

interventional trials among women with recurrent pregnancy loss and antiphospholipid syndrome and other acquired thrombophilias suggest it is both safe and effective.<sup>251,279,280,281</sup> When LMWH and aspirin treatment was directly compared with UFH and aspirin treatment, there were no differences in pregnancy outcome.<sup>282,283</sup> Therefore, both UFH with aspirin and LMWH with aspirin treatment can be utilized for women with aPL and RPL. Prednisone may have some efficacy in the treatment of women with recurrent pregnancy loss and antiphospholipid syndrome, but its risks (diabetes, hypertension, preterm delivery) outweigh its benefits.<sup>284,285</sup> Combined treatment with aspirin and heparin is effective and also safer. Intravenous immunoglobulins have also been used to treat women with recurrent pregnancy loss and antiphospholipid syndrome. Overall, there is evidence from randomized clinical trials for a significant increase in live births following intravenous immunoglobulin G (IVIg) in women with secondary recurrent miscarriage, but there is insufficient evidence to support its use in primary recurrent pregnancy loss.<sup>286</sup> The efficacy of IVIg has not been compared directly to heparin/aspirin or LMWH/aspirin.<sup>287,288</sup>

Although an increased prevalence of antithyroid antibodies and antinuclear antibodies has been observed in women with recurrent pregnancy loss, their relevance is uncertain because neither predicts subsequent pregnancy outcome, and there is no logical and proven effective treatment to offer.<sup>233,289,290</sup> Treatment with levothyroxine in thyroid antibody-positive women undergoing assisted reproduction technologies had no impact on outcomes.<sup>291</sup> Of course, if TSH levels are elevated, even in the range of subclinical hypothyroidism, as discussed later in this chapter, treatment is indicated. Tests to detect antinuclear and antithyroid antibodies have no clinical utility in euthyroid women with recurrent pregnancy loss. However, women with thyroid antibodies have a significant risk of becoming hypothyroid as pregnancy progresses and also an increased risk of postpartum thyroiditis.<sup>292</sup>

An uncommon autoimmune condition, celiac disease, may be linked with recurrent miscarriages and may require appropriate antibody testing in its subclinical form.<sup>293</sup> Another unusual cause of recurrent miscarriages is antibody formation related to a rare blood group, P type. Patients with this condition treated with plasmapheresis have achieved successful pregnancies.<sup>294</sup>

## **Summary of Key Facts Relating to Autoimmune Factors**

**Autoimmune diseases like systemic lupus erythematosus and the antiphospholipid syndrome are identifiable and treatable immunologic disorders associated with recurrent pregnancy loss. A variety of mechanisms can explain how antiphospholipid antibodies predispose to placental thrombosis or interfere with**

**normal development of the uteroplacental circulation to cause both early and late pregnancy losses. At the present time, assays for the lupus anticoagulant, anticardiolipin antibodies, and anti- $\beta$ 2-glycoprotein 1 antibodies are the only validated immunologic tests having clinical utility in the evaluation of women with recurrent pregnancy loss. As yet, assays for other antiphospholipid antibodies have no proven value. Combined aspirin and heparin therapy has proven effectiveness and is the preferred treatment for women with recurrent pregnancy loss associated with antiphospholipid syndrome. Aspirin in combination with either UFH or LMWH has similar efficacy in treatment of women with recurrent pregnancy loss associated with antiphospholipid syndrome.**



# Alloimmune Disorders

In theory, normal pregnancy requires maternal immunologic recognition and response to paternally derived antigens on embryonic tissues, and abnormalities in the maternal alloimmune response may predispose to or cause recurrent pregnancy loss. Suggested mechanisms have included maternal production of cytotoxic antibodies, maternal failure to produce blocking antibodies to prevent a maternal cell-mediated immune attack (possibly because mother and father are too antigenically similar), and cytokine dysregulation of immune mechanisms operating at the maternal-fetal interface.

Antipaternal lymphocytotoxic antibodies have been proposed as a cause of recurrent pregnancy loss.<sup>295</sup> However, they are also present in many women with normal pregnancies and are more prevalent in fertile couples than in those with recurrent pregnancy loss.<sup>296,297</sup> These observations have led most to conclude that lymphocytotoxic antibodies reflect the number and duration of pregnancies and have no effect on subsequent pregnancy outcome.<sup>297,298</sup>

In contrast to the cytotoxic antibody theory, the maternal blocking antibody theory of recurrent pregnancy loss holds that maternal failure to recognize and respond to fetal antigens by production of blocking factors (presumably antibodies) leaves the embryo exposed to a lethal cell-mediated immune rejection.<sup>299</sup> A poor maternal response to paternal cells in mixed lymphocyte culture was regarded as evidence for the putative immune deficiency in women with recurrent pregnancy loss.<sup>300</sup> However, blocking antibodies were not always detectable in women with normal pregnancies<sup>300</sup> but frequently were detected in women with recurrent pregnancy loss,<sup>301</sup> and their presence does not accurately predict subsequent pregnancy outcome.<sup>298</sup> Again, these effects are more likely to reflect the results of previous pregnancies than to explain their outcomes.<sup>297,302</sup>

Increased sharing of major histocompatibility complex human leukocyte antigens (HLA) between mother and father was seen as one factor that might hamper maternal recognition of paternally derived fetal antigens and production of presumed essential blocking antibodies.<sup>299</sup> Numerous studies have examined HLA sharing in couples with recurrent pregnancy loss, but results have varied widely.<sup>302</sup> The best evidence that increased HLA sharing might predispose to recurrent pregnancy loss came from a study in the Hutterites, a highly inbred religious sect wherein HLA sharing was associated with increased risk for pregnancy loss, but in outbred populations at low risk for HLA homogeneity, HLA sharing does not predict pregnancy outcome and testing has no clinical utility.<sup>303,304</sup> Indeed, in a subsequent study of the Hutterites, genotyping for HLA loci (the previous study was with serologic measurements) could not detect any

influence of HLA haplotypes on fetal loss.<sup>305</sup>

Human leukocyte antigen-G (HLA-G) blocks killer cell activity by binding to killer cell receptors. Sequencing of the HLA-G gene indicated a variety of differences in women with recurrent pregnancy losses, polymorphisms that could account for lowered levels of HLA-G and an increased risk of miscarriage.<sup>306,307</sup> In time, this type of genetic profiling could delineate specific molecular mechanisms for fetal rejection.

The idea that successful pregnancy requires some type of maternal immune suppression remains attractive. The most recent concept to emerge has implicated dysregulation of local immune functions at the maternal-fetal interface as a cause of recurrent pregnancy loss. Investigations have focused on a unique population of large granular lymphocytes related to NK cells that predominate in the decidua and on the patterns of cytokine secretion by maternal immune cells in response to trophoblast antigens.

The large granular lymphocytes present in the early pregnancy decidua appear to be regulated by both hormone changes and trophoblast invasion.<sup>308,309</sup> Increased numbers of these decidual NK cells have been observed in mouse models of recurrent pregnancy loss, and the abortion rate in mice increases when NK cells are activated and decreases when they are depleted.<sup>310,311</sup> Later studies in mice lacking all lymphocytes, including NK cells, showed distinct histologic changes and lack of spiral arterial modification in implantation sites, suggesting that NK cells are involved in decidual angiogenesis.<sup>312,313</sup> However, despite these features, litters of normal size are born apparently due to a series of maternal and cardiovascular growth adjustments.<sup>314</sup> Thus, NK cell functions in pregnancy are still poorly defined. In women with recurrent pregnancy loss, increased decidual NK cell activity has been observed,<sup>315,316</sup> and increased numbers of peripheral NK cells have been associated with subsequent pregnancy failure.<sup>317,318</sup> However, whether changes in peripheral NK cells mirror those occurring in the decidua and whether changes observed in the decidua are the result or the cause of pregnancy loss remain unclear.<sup>319,320</sup>

Antigen-stimulated immune responses involving T-helper lymphocytes are of two basic varieties that reflect the environment in which the cells mature and differentiate; those exposed to interferon (INF)- $\gamma$  become T-helper lymphocyte-1 cells, and those exposed to interleukin (IL)-4 become T-helper lymphocyte-2 cells.<sup>321,322</sup> T-helper lymphocyte-1 cell responses are associated with inflammation and typically characterized by the release of INF- $\gamma$  and IL-12, IL-2, and tumor necrosis factor (TNF)- $\alpha$ . T-helper lymphocyte-2 cell responses are associated with antibody production and the cytokines IL-10, IL-4, IL-5, and IL-6.<sup>323,324</sup> TNF- $\alpha$  can be secreted by both T-helper lymphocyte-1 and T-helper lymphocyte-2 cells but is usually associated with a T-helper

lymphocyte-1 response.<sup>324</sup> TNF- $\alpha$  variant polymorphisms have been identified in women with recurrent miscarriages.<sup>324,325</sup> Whereas most women with normal pregnancies appear to have a predominant T-helper lymphocyte-2 immune response to undefined trophoblast antigens, some women with recurrent pregnancy loss exhibit a T-helper lymphocyte-1 inflammatory response that may be harmful to an implanting embryo.<sup>327,328,329,330,331</sup>

Approximately 15–20% of women with unexplained recurrent pregnancy loss exhibit an abnormal T-helper lymphocyte-1 cellular immune response to trophoblast antigens in vitro, compared to less than 3% of women with normal reproductive histories.<sup>327,328,329,332,333,334</sup> CD4(+)CD25(+) T cells play a role in preventing fetal rejection; the proportion of these cells is lower in decidua and blood obtained from women with recurrent miscarriages.<sup>335,336</sup> Once again, whether the cytokine secretory patterns of peripheral lymphocytes accurately reflect what is occurring at the maternal-fetal interface and whether T-helper lymphocyte-1 response patterns are the cause or the effect of pregnancy loss remain uncertain and controversial.

Studies have assessed cytokine expression in trophoblast tissue, assuming that altered expression would be a marker for fetal rejection. Indeed, IL expression is increased in placental tissue obtained from patients with recurrent miscarriages,<sup>337</sup> but again, it is difficult to know whether this is a primary or secondary event. Researches for cytokine polymorphisms in women with recurrent miscarriages have not been fruitful.<sup>338,339,340,341</sup>

The idea that abnormal maternal cellular or humoral immune responses to trophoblast antigens may be a cause of recurrent pregnancy loss has stimulated development of two distinctly different immunotherapies for women with unexplained and presumed alloimmune-mediated recurrent pregnancy loss, one immunostimulatory (paternal leukocyte immunization) and the other immunosuppressive (intravenous immunoglobulins).

Paternal leukocyte immunization is based on the beneficial effects that donor or third-party leukocytes have on allograft rejection in transplant patients and evidence that it may decrease the number of circulating NK cells in women with recurrent pregnancy loss.<sup>342</sup> Numerous small randomized and nonrandomized trials and meta-analyses yielded widely varying and conflicting results. Altogether, they suggested that, at best, a relatively small treatment effect (8–10% improvement in live birth rate) had to be weighed against the costs and risks of treatment (injection site reactions, fever, myalgias, platelet and erythrocyte alloimmunization).<sup>302</sup> **A large randomized controlled multicenter trial found no evidence that paternal leukocyte immunization was effective in the treatment of unexplained recurrent pregnancy**

loss, regardless of maternal age, number of previous miscarriages, and whether the couple had a previous live birth, and concluded that paternal leukocyte immunization should not be offered as treatment for recurrent pregnancy loss.<sup>343</sup> A comprehensive meta-analysis of treatment trials drew the same conclusion.<sup>344</sup>

Intravenous immunoglobulins are prepared by isolating and pooling immunoglobulin proteins from the serum of a large number of volunteer blood donors (up to 150 donors per vial) and generally may be regarded as immunosuppressive, acting through a number of different mechanisms.<sup>345</sup> Intravenous immunoglobulins treatment is costly, requires a number of intravenous infusions over the course of pregnancy, and carries risks including transmission of infections (viruses, prions) and anaphylaxis.<sup>346</sup> **A substantial number of randomized trials of intravenous immunoglobulins therapy in women with unexplained recurrent pregnancy loss have now been conducted. Taken together, the results failed to demonstrate that intravenous immunoglobulins are effective in improving pregnancy outcomes for women with unexplained recurrent pregnancy loss.**<sup>302,344,347</sup>

A Cochrane review of randomized trials (12 trials, 641 women) concluded that immunotherapy (including paternal leukocyte immunization, intravenous immune globulin, third-party donor leukocytes, and trophoblast membranes) did not improve the live birth rate compared with placebo treatment.<sup>348</sup>

New treatment options include TNF-inhibiting factor and granulocyte colony-stimulating factor (GCSF). The administration of the cytokine GCSF in a small clinical trial improved the live birth rate in women with recurrent miscarriages, while no beneficial effect on live birth was observed in another study.<sup>349,350</sup>

## **Summary of Key Facts Relating to Alloimmune Factors**

**Maternal immune recognition and response doubtless play an important role in normal pregnancy, and alloimmune disorders may be a cause of otherwise unexplained recurrent pregnancy loss. At present, cytokine dysregulation of immune mechanisms operating at the maternal-fetal interface is the most likely pathophysiologic mechanism involved. However, all current methods for the evaluation of suspected alloimmunopathology, including HLA testing, immune cell evaluation (mixed lymphocyte culture, natural killer cell assays), and cytokine testing (to differentiate those with T-helper lymphocyte-1 and T-helper lymphocyte-2 patterns of immune responses to trophoblast antigens in vitro), must be considered investigational. Furthermore, neither of the two principal immunotherapies advocated for the treatment of presumed alloimmune disorders in**

**women with unexplained recurrent pregnancy loss (paternal leukocyte immunization, intravenous immunoglobulins) has proven effective.**

# INHERITED THROMBOPHILIAS

---

Interest in inherited thrombophilias as a potential cause of recurrent pregnancy loss emerged quite naturally after antiphospholipid syndrome (an acquired thrombophilia) was established as a significant and treatable cause of recurrent pregnancy loss. The pathophysiologic concept is the same: in some women with recurrent pregnancy loss, the thrombogenic changes of pregnancy exaggerate an inherent predisposition to thrombosis, resulting in reduced uteroplacental blood flow, placental thrombosis, and pregnancy loss. Although **there is little argument that pregnancy is a thrombogenic state and** an association between hereditary thrombophilias and fetal loss has been suggested, recent prospective cohort studies have failed to confirm such an association, raising doubt on **the importance of inherited thrombophilias as a cause of recurrent pregnancy loss.**

Viewed simply, pathologic thrombosis results from an imbalance between coagulation and fibrinolysis, reflecting an imbalance between clotting factors, anticoagulant proteins (protein C, protein S, antithrombin III), and fibrinolytic mechanisms. Normal pregnancy is a hypercoagulable state characterized by increased levels of factors V, VII, VIII, and X and fibrinogen, decreased levels of protein S, increased resistance to activated protein C, higher concentrations of plasminogen activator inhibitors (PAI), and an increased tendency to platelet aggregation, all promoting thrombosis ([Table 30.3](#)).

## TABLE 30.3 Coagulation and Fibrinolysis Factors

## Coagulation factors

---

*Factors that favor clotting  
when increased*

Fibrinogen  
Factors VII, VIII, X

---

*Factors that favor clotting  
when decreased*

Antithrombin III  
Protein C  
Protein S

---

## Fibrinolysis factors

---

*Factors that favor clotting  
when increased*

Plasminogen activator inhibitor-1  
(PAI-1)

---

*Factors that favor clotting  
when decreased*

Antiplasmin

---

A variety of genetic mutations may result in an inherited predisposition to thrombosis. Among these, the factor V Leiden mutation (G → A at nucleotide 1691)<sup>351,352</sup> and another involving the prothrombin gene (G → A at nucleotide 20210)<sup>353</sup> are the most common. A third relatively common mutation involves the gene encoding the enzyme methylene tetrahydrofolate reductase (C → T at nucleotide 677); homozygotes are predisposed to hyperhomocysteinemia, a known risk factor for thrombosis.<sup>354</sup> Other established inherited thrombophilias include deficiencies of antithrombin III, protein S, and protein C. A deficiency of factor XII (involved in both coagulation and fibrinolysis) is yet another abnormality implicated as predisposing to thrombosis and pregnancy loss.<sup>355</sup>

Protein C is a key component in the anticoagulant pathway and, when activated, inhibits the actions of clotting factors V and VIII; protein S serves as a cofactor to facilitate the actions of activated protein C. Resistance to the anticoagulant properties of activated protein C can be inherited or acquired and, in either case, results in increased

thrombin generation and a hypercoagulable state. Approximately 95% of activated protein C resistance is related to the factor V Leiden mutation, which yields an altered form of factor V that is resistant to the action of activated protein C.<sup>264,356</sup> The prevalence of the factor V Leiden mutation varies between 2% and 10% in Western populations. The risk of systemic thrombosis is increased fivefold in heterozygotes and is 80 times higher in those who are homozygous for the mutation.<sup>264</sup> In some individuals, resistance to activated protein C is acquired rather than inherited.

All risk factors for thrombosis increase risk for pregnancy complications related to thrombosis, including miscarriage, preeclampsia, placental abruption, intrauterine growth restriction, and stillbirth. The association between thrombophilias and pregnancy loss varies with the type of pregnancy loss (early, late) and the thrombophilia. A meta-analysis including data from 31 studies found that although thrombophilias are associated with both early and late pregnancy loss, the association is stronger for second-trimester and later losses than for early miscarriage.<sup>357</sup> The observation is not surprising when one considers that maternal intervillous blood flow does not develop to any appreciable degree before approximately 8 weeks' gestation (at the earliest); thrombosis related to thrombophilia, therefore, is less likely to explain earlier pregnancy losses.<sup>358</sup> The association between thrombophilias and pregnancy loss is also stronger for factor V Leiden, the prothrombin gene mutation, and protein S deficiency than for other thrombophilic defects.<sup>357,359</sup>

Numerous studies have compared the prevalence of various thrombophilias in women with recurrent pregnancy loss to those in parous controls, with conflicting results. Some have observed an increased prevalence of thrombophilias among women with recurrent pregnancy loss and others have not.<sup>359,360,361,362,363,364,365</sup> In one study of 1,000 consecutive Caucasian women with recurrent pregnancy loss, the prevalence of the factor V Leiden mutation in women with early (3.3%) and late pregnancy loss (3.9%) was similar to that observed in a parous control group (4.0%), but the prevalence of acquired activated protein C resistance was significantly greater among women with both early (8.8%) and late miscarriages (8.7%) than in normal parous controls (3.3%).<sup>367</sup> These observations suggest that acquired thrombophilias may be as or even more important than inherited defects as a cause of recurrent pregnancy loss.

Another group of studies has taken the opposite approach and examined the past reproductive performance of women known to carry thrombophilias and, in general, found a relatively strong relationship between maternal thrombophilic defects and adverse late pregnancy outcomes.<sup>368,369</sup> In a prospective study, the live birth rate observed among untreated women with a history of recurrent pregnancy loss or late pregnancy loss and heterozygous for the factor V Leiden allele (38%) was substantially lower than among women with similar reproductive histories having a normal factor V



genotype (69%).<sup>358</sup> Whereas pregnancy losses among women with recurrent pregnancy loss and factor V Leiden occurred both early and late, all losses observed among women without the thrombophilia occurred before 12 weeks' gestation. **The available evidence suggests that thrombophilias predispose to a higher risk of both early and late pregnancy losses.**<sup>370,371</sup> **However, they also demonstrate that reproductive performance is entirely normal for many women who carry thrombophilia. At the present time, it cannot be established who among women with recurrent pregnancy loss that carry thrombophilia is truly at increased risk for pregnancy loss.**

The risk of systemic thrombosis rises when more than one inherited thrombophilia is present, and evidence indicates that the same may be true for the risk of adverse pregnancy outcomes relating to maternal thrombophilias.<sup>368,369,371</sup> The genotype of the embryo or fetus may also have important influence on the risk of pregnancy loss in women with thrombophilias; placental infarction has been observed more often when the fetus also carries the factor V Leiden allele than when it has a normal factor V genotype.<sup>372</sup>

**Routine testing of women with recurrent pregnancy loss for inherited thrombophilias is not currently recommended (ASRM 2012). Screening for inherited thrombophilias (specifically, factor V Leiden and the prothrombin gene mutations, protein C, protein S, and antithrombin deficiencies) seems reasonable when a patient has a personal history of venous thromboembolism in the setting of a nonrecurrent risk factor (such as surgery) or a first-degree relative with a known or suspected high-risk thrombophilia.** In addition to a lupus anticoagulant, anticardiolipin, and anti- $\beta$ 2-glycoprotein 1 for diagnosis of antiphospholipid syndrome (an acquired thrombophilia), screening includes tests for the factor V Leiden and G20210A prothrombin gene mutations. They are the two most common inherited causes of venous thromboembolism and thrombophilias most highly associated with adverse pregnancy outcomes, but race must also be considered. Their prevalence is relatively high among those of European descent, but very low in Asians, Africans, and Native Americans.<sup>373</sup> Measurement of activated protein C resistance is a more global test for detection of both inherited and acquired forms of activated protein C resistance. Screening for the methylene tetrahydrofolate reductase mutation (serum homocysteine) and antithrombin III, protein S, and protein C deficiencies also warrants consideration, based on past and family medical history.

Indications for treatment in women with recurrent pregnancy loss associated with thrombophilia are even less well established. In uncontrolled treatment trials, improved live birth rates have been observed in women with recurrent pregnancy loss and one or more thrombophilic defects after treatment with heparin, alone or combined with aspirin.<sup>280,281,374,375</sup> Although it seems likely that not all such women truly require

treatment, any criteria for more selective or targeted thromboprophylaxis must derive from randomized controlled trials not yet available. Routine empiric aspirin treatment in untested women with recurrent early pregnancy loss has no proven benefit.<sup>361</sup>

# **Summary of Key Facts Relating to Inherited Thrombophilias**

**Inherited thrombophilias resulting from genetic mutations in clotting factors have emerged as a potentially important cause of recurrent pregnancy loss, but a great many women with these mutations have completely normal reproductive performance. Why some with thrombophilias miscarry and others do not is unknown; women with more than one type of mutation or whose fetus inherits the mutation may be at greater risk. At present, which women with recurrent pregnancy loss should be screened for thrombophilias and how they should be evaluated remain unanswered questions. Selected screening for the most common abnormalities in women with otherwise unexplained recurrent pregnancy loss with a suspicious loss after 8 weeks' gestation or after detection of fetal heart activity is reasonable, but routine screening of all women with recurrent pregnancy loss cannot be justified. Whereas preliminary data suggest that treatment with heparin may improve pregnancy outcomes in women with recurrent pregnancy loss who carry thrombophilia, empiric aspirin treatment in untested women has no proven benefit.**

# ENDOCRINE FACTORS

---

Endocrine factors that may predispose to an increased risk of pregnancy loss include thyroid disease, diabetes mellitus, polycystic ovary syndrome (PCOS), and luteal phase deficiency.

# Hypothyroidism

Risk of pregnancy loss may be increased for women with uncorrected overt or even subclinical hypothyroidism.<sup>376</sup> Mild or subclinical disease generally was not considered in the past as having important clinical consequences.<sup>377,378</sup> However, the results of a study of pregnancy outcomes in women with hypothyroidism challenge that notion. The incidence of pregnancy loss was very low in treated hypothyroid women having normal thyroid indices, but markedly increased in women with elevated thyroid-stimulating hormone (TSH) levels, including both women with untreated subclinical disease and those with overt disease who received inadequate exogenous thyroid hormone replacement.<sup>376</sup> The classic TSH threshold definition of hypothyroidism is TSH greater than 5 mIU/L. However, there is conflicting data that TSH levels of less than 5 mIU/L are also associated with increased risk of miscarriage. Several studies have found that elevated TSH levels in pregnancy are associated with an increased risk of miscarriage in patients without a diagnosis of hypothyroidism.<sup>379,380,381</sup> Other studies have shown no increased risk of miscarriage with subtle thyroid abnormalities. In a subset of patients from the first- and second-trimester evaluation of risk (FASTER) trial, 2.2% of patients were found to have TSH  $\geq$  2.5 mIU/L, and the miscarriage risk in this group was no different than the group with TSH less than 2.5 mIU/L.<sup>382</sup> Another study that reviewed 1,200 cycles in infertile women found that there was no difference in miscarriage rate between those with TSH between 2.5 and 4.0 and those with TSH less than 2.5.<sup>383</sup> **These observations suggest that subclinical hypothyroidism is not entirely benign and further justify earlier recommendations to include TSH screening in the evaluation of women with recurrent pregnancy loss.** Available evidence suggests that subclinical hypothyroidism defined as TSH greater than 4 mIU/L is associated with miscarriage and that treatment is associated with improved pregnancy rates. Diagnosis and treatment of even subtle thyroid disease can have important benefits for women with recurrent pregnancy loss.

Remember (see [Chapter 20](#)) that once pregnant, women being treated for hypothyroidism require an increase (20–50%) in thyroxine during pregnancy, beginning as early as the 5th week of pregnancy.<sup>384,385,386</sup> When previously diagnosed hypothyroid women become pregnant, it is best to empirically increase the levothyroxine dose by about 30% as soon as pregnancy is diagnosed, with further adjustments according to the TSH levels.<sup>386,387</sup> **TSH should be monitored monthly and again in the postpartum period, and dosage should be adjusted to keep the TSH level in the lower half of the normal range, less than 2.5 mU/mL in the first trimester and less than 3.0 mU/mL in the rest of pregnancy.** Postpartum, the dose should be immediately decreased to the prepregnancy level. The need for proper monitoring and adequate

treatment cannot be overemphasized. Women with thyroid autoimmunity (presence of thyroid antibodies) must be monitored with TSH levels for at least 6 months after delivery because of their increased risk for postpartum thyroiditis.

# Diabetes Mellitus

Diabetic women with good metabolic control are no more likely than nondiabetic women to suffer pregnancy loss, but diabetic women with elevated blood glucose and glycosylated hemoglobin (A1c) levels in the first trimester are at significantly increased risk for spontaneous miscarriage. Among women with poor diabetic control, miscarriage risk rises with the level of hemoglobin A1c.<sup>388,389,390,391</sup> **In women with recurrent pregnancy loss, evaluation with blood glucose and hemoglobin A1c levels is indicated for those with known or suspected diabetes but is otherwise unwarranted.** Diabetic women with recurrent pregnancy loss and elevated hemoglobin A1c concentrations are best advised to postpone new attempts to conceive until levels return to the normal range.

# Polycystic Ovary Syndrome

A number of studies have shown a correlation between elevated luteinizing hormone (LH) levels and recurrent pregnancy loss.<sup>392,393</sup> In the past, the observation was attributed to the adverse effects of LH itself or the hyperandrogenism induced by LH hypersecretion in women with PCOS.<sup>394,395</sup> However, suppression of LH secretion with a gonadotropin-releasing hormone (GnRH) agonist before ovulation induction with low-dose exogenous gonadotropins had no effect on pregnancy outcome in women with PCOS.<sup>396</sup> Hyperinsulinemia and high levels of PAI activity have been implicated as the proximate cause for the increased incidence of miscarriage (30–50%) observed among women with PCOS.<sup>392,395,397</sup> Metformin is an insulin-sensitizing drug with proven clinical utility for ovulation induction in anovulatory women with PCOS<sup>398,399,400,401</sup> and has also been demonstrated to decrease PAI activity.<sup>402,403,404,405</sup> Accordingly, metformin treatment before conception and throughout pregnancy has been evaluated as one means by which risk of pregnancy loss might be reduced in women with PCOS.

Results of retrospective studies suggested that metformin treatment can reduce or eliminate the increased risk of miscarriage in women with PCOS.<sup>406,407,408,409</sup> However, randomized trials comparing metformin and clomiphene, alone and in combination, have found that clomiphene is clearly superior to metformin and that combined treatment is no better than treatment with clomiphene alone.<sup>410,411,412</sup> In the largest single trial, the live birth rate achieved with clomiphene treatment was significantly higher than that of metformin (22.5% vs. 7.2%), and the results of combined treatment were not significantly different (26.8%).<sup>411</sup> More recently, in a follow-up trial, letrozole was shown to be associated with higher live births than clomiphene in infertile women with PCOS.<sup>413</sup> Although some have advocated metformin treatment to reduce the increased risk for miscarriage in women with PCOS, which might relate to an underlying metabolic disorder,<sup>414</sup> **no differences in the miscarriage rates of women who did or did not receive metformin treatment have been observed in the large randomized trials.**<sup>410,411,412</sup> **A meta-analysis of 17 randomized trials concluded that metformin treatment had no effect on the risk of miscarriage.**<sup>415</sup>

Metformin may be added to the treatment regimen when clomiphene alone fails to restore normal ovulatory function. Metformin treatment can be discontinued after conception or after the end of the first trimester or continued throughout pregnancy in hopes of also reducing the risk for developing gestational diabetes.<sup>416,417,418</sup> Metformin is classified as a category B drug (no teratogenic effects demonstrated in animal studies and no teratogenic or other serious adverse effects have been observed in limited studies in women thus far).<sup>417,419,420</sup> However, treatment with metformin during



pregnancy has been associated with an increased prevalence of preeclampsia and increased perinatal mortality in some studies,<sup>421</sup> although not in others.<sup>422</sup> Currently, **routine** metformin treatment during pregnancy is not recommended for women with PCOS.<sup>422</sup>

# Luteal Phase Deficiency

The many different causes of poor luteal function and methods for the clinical diagnosis of luteal phase deficiency are discussed at length in the context of the evaluation of female infertility in [Chapter 25](#). Discussion here is limited to a summary of the pathophysiology, diagnosis, and treatment of luteal phase deficiency in women with recurrent pregnancy loss.

Several lines of evidence indicate that the success of early pregnancy is dependent on progesterational support from the corpus luteum until approximately 7 weeks' gestation (menstrual dates). Serial measurements of 17-hydroxyprogesterone (produced by the corpus luteum but not by the trophoblast), progesterone, estradiol, and hCG during early spontaneous pregnancies and pregnancies achieved via IVF using donor oocytes in women with ovarian failure indicate that the luteal-placental shift does not occur suddenly but takes place gradually over the interval spanning the 5th through the 9th week of pregnancy.<sup>424,425</sup> Classic studies of pregnancy outcomes in women seeking pregnancy termination who underwent surgical luteectomy at various times during early gestation strongly suggest that pregnancy usually becomes independent of the corpus luteum at approximately 7 weeks' gestation; luteectomies performed earlier in pregnancy uniformly induced spontaneous miscarriage.<sup>426,427</sup>

Progesterone concentrations in both normal and abnormal early pregnancies reflect the combined contributions of the corpus luteum and the developing trophoblast, range widely, and overlap to a large extent.<sup>424,428,429,430,431</sup> **Measurements of serum progesterone levels to determine the quality of luteal function in early pregnancy and to identify pregnancies at risk that might be salvaged by support with exogenous progesterone therapy are futile.** A low progesterone concentration during early pregnancy can reflect a defective corpus luteum, an intrinsically abnormal conceptus, or both. The alternative approach, diagnosis in a nonconception cycle and treatment to correct luteal phase deficiency before the next conception, is possible but subject to all of the limitations and pitfalls of the various diagnostic methods. Serum progesterone concentrations fluctuate widely and cannot be confidently interpreted because corpus luteum progesterone secretion is pulsatile.<sup>432</sup> Endometrial biopsy is invasive, painful, and costly, even if traditional histologic dating were still considered a valid diagnostic tool.<sup>433</sup> Consequently, an abnormally short luteal phase duration (<13 days), best defined by the interval from detection of the midcycle LH surge to the onset of menses, is the most objective and reliable diagnostic criterion. When that criterion is met, a serum prolactin determination is indicated to exclude hyperprolactinemia and to define the best treatment option. Estimates of the prevalence of luteal phase deficiency among women with recurrent pregnancy loss have varied greatly with the method of

diagnosis<sup>51,52,53,55,56,434</sup>; its true prevalence and importance as a cause of recurrent pregnancy loss is unknown, but probably quite low (<10%).

We view luteal phase deficiency as a subtle form of ovulation dysfunction best corrected with the same treatments used for ovulation induction in anovulatory infertile women (Chapter 27). Considering that women with luteal phase deficiency already ovulate, albeit poorly, they generally do not require aggressive treatment. Prolactin and TSH determinations are indicated, and clomiphene citrate is a logical choice in euprolactinemic euthyroid women. There is a large volume of experimental and clinical evidence to indicate that follicular phase FSH levels are low in cycles with a short luteal phase<sup>435,436,437,438,439</sup> and that clomiphene can effectively correct the abnormality.<sup>440,441</sup> Some prefer to treat luteal phase deficiency with exogenous progesterone supplementation beginning 2–3 days after ovulation,<sup>442</sup> but this approach often delays menses, creating false expectations of pregnancy, increasing stress, and inviting disappointment.

# **Summary of Key Facts Relating to Endocrine Factors**

**Endocrine factors are a relatively uncommon cause of recurrent pregnancy loss. Thyroid disorders are easy to identify and treat and should be excluded by measurement of TSH; even subtle abnormalities may adversely affect pregnancy outcome. Evaluation of blood glucose and hemoglobin A1c levels is indicated for women with known or suspected diabetes mellitus, but is otherwise not warranted. The risk of miscarriage is increased in women with polycystic ovary syndrome, but there is no evidence that treatment with metformin reduces that risk; for women with polycystic ovary syndrome and hyperinsulinemia who require ovulation induction, letrozole is the best initial treatment, which may be combined with metformin. Luteal phase deficiency cannot be diagnosed during pregnancy; a consistently short luteal phase duration is the most reliable diagnostic criterion. Clomiphene citrate is an effective treatment for luteal phase deficiency and avoids the confusion, anxiety, and disappointment associated with delayed menses often resulting from exogenous progesterone therapy.**

# INFECTIOUS CAUSES

---

Overall, data regarding the possibility that cervicovaginal infections might be a cause of early pregnancy loss are relatively scarce. Despite periodic reports that have implicated specific infectious agents as risk factors for miscarriages, there remains no compelling evidence that bacterial or viral infections are a cause of recurrent pregnancy loss. Chlamydia trachomatis infection was implicated in one study that found a high prevalence of anti-Chlamydia antibodies among women with recurrent pregnancy loss, possibly reflecting an excessive maternal immunologic reaction to the organism,<sup>443</sup> but a later prospective study found no association between anti-Chlamydia antibodies and spontaneous miscarriage.<sup>444</sup> Others have reported associations between spontaneous miscarriage and genital Ureaplasma (*U. urealyticum*) or Mycoplasma (*M. hominis*) infection.<sup>445</sup> Toxoplasma gondii, Listeria monocytogenes, Campylobacter species, herpes virus, and cytomegalovirus have also been implicated.

There is an association between miscarriage risk and bacterial vaginosis. In one large study, diagnosis of bacterial vaginosis at the first prenatal visit before 14 weeks' gestation was associated with a fivefold increased risk of pregnancy loss before 20 weeks' gestation.<sup>446</sup> Another study involving infertile women attempting pregnancy via IVF observed no difference between conception rates in women with and without bacterial vaginosis, but those with bacterial vaginosis who conceived were twice as likely to miscarry as those without bacterial vaginosis who conceived.<sup>447</sup> A third large study found that bacterial vaginosis did not predict early miscarriage but was associated with a modest increase in risk of pregnancy loss after 13 weeks' gestation.<sup>448</sup> Other evidence that chronic subclinical endometritis is relatively common in women with symptomatic lower genital tract infections, including cervicitis and bacterial vaginosis, suggests a mechanism that might explain the association between bacterial vaginosis and pregnancy loss.<sup>449,450,451</sup>

The available data cannot justify routine serologic testing for past Chlamydia exposure, cervical cultures, or endometrial biopsy in the evaluation of women with recurrent pregnancy loss. However, as in infertile women, further evaluation and treatment are appropriate and prudent in women with recurrent pregnancy loss having clinical cervicitis, chronic or recurrent bacterial vaginosis, or other symptoms that suggest pelvic infection. Uncontrolled studies have suggested that empiric antibiotic treatment may decrease the risk of miscarriage in women with genital mycoplasma infections<sup>452</sup> and in unselected women with recurrent pregnancy loss.<sup>453,454</sup> **Considering the relatively low cost and negligible risks involved, a 2-week course of empiric antibiotic treatment (azithromycin, erythromycin, or doxycycline) is more reasonable than numerous and repeated cultures.**

An analysis of the two large clinical trials that established the efficacy of the bivalent vaccine against human papillomavirus (HPV) types 16 and 18 could detect no increase in the miscarriage rate comparing the vaccinated women with the control group.<sup>455</sup>

# **Summary of Key Facts Relating to Infectious Causes**

**Routine serologic testing, cervical cultures, and endometrial biopsy to detect genital infections in women with recurrent pregnancy loss cannot be justified. Evaluation should be limited to women with clinical cervicitis, chronic or recurrent bacterial vaginosis, or other symptoms of pelvic infection. Empiric antibiotic treatment in women suspected of harboring a genital mycoplasma infection is less costly and less complicated than serial cultures.**

# ENVIRONMENTAL FACTORS

---

Smoking, alcohol, and heavy coffee consumption have been implicated as environmental factors predisposing to pregnancy loss.

Numerous studies have examined the relationship between cigarette smoking and miscarriage risk.<sup>456,457</sup> In sum, they support the conclusion that cigarette smoking increases the risk of spontaneous miscarriage in a dose-dependent manner<sup>458,459,460,461,462,463,464</sup>; the adverse effects of smoking become apparent in smokers who consume as few as 10 cigarettes per day.<sup>457</sup> The mechanisms responsible are uncertain but the vasoconstrictive and antimetabolic actions of some components of cigarette smoke, including nicotine, carbon dioxide, and cyanide, may predispose to placental insufficiency.

Alcohol is a known teratogen with dose-dependent adverse effects.<sup>456,464,465,466</sup> Alcohol consumption exceeding two drinks per day has been estimated to double the risk of spontaneous miscarriage.<sup>456</sup> Although low-level consumption has no measurable impact on the risk of pregnancy loss,<sup>467</sup> there is no clearly established safe threshold. The adverse effects of alcohol may be additive with those of cigarette smoking.

Most, but not all, studies that have examined the relationship between maternal caffeine consumption and miscarriage risk have found that heavy caffeine consumption (>300 mg/day, equivalent to about three cups of coffee) is associated with a modest increase (less than twofold) in risk for spontaneous miscarriage.<sup>468,469,470,471,472,473,474,475</sup>

Couples experiencing recurrent pregnancy loss are sometimes concerned that environmental toxins may have contributed to their reproductive difficulty. Their questions are difficult to answer because information regarding the effects of potential toxins on pregnancy is not readily available. Anesthetic gases, perchlorethylene (a dry-cleaning solvent), other organic solvents,<sup>476</sup> and exposure to heavy metals (mercury, lead) have been implicated as causative agents of miscarriage.<sup>464</sup> Exposure to video terminals is not a factor.<sup>477</sup> Exercise programs do not increase risk, and bed rest will not decrease the risk of recurrent pregnancy loss. Isotretinoin (Accutane) is definitely associated with an increased incidence of spontaneous miscarriage.<sup>478</sup> An increased miscarriage risk has been observed among painters and factory workers, but not among dental assistants and laboratory or gardening workers.<sup>479,480</sup> The use of electric blankets and heated water beds is also not associated with an increased risk of spontaneous miscarriage.<sup>481</sup>

It seems appropriate to list obesity under environmental factors because excess weight is largely a consequence of lifestyle. A body mass index (BMI) equal to or



greater than 25 is associated with a greater risk of miscarriage, and Chinese and British studies have linked obesity with recurrent miscarriages. [482,483,484](#)

# Summary of Key Facts Relating to Environmental Factors

Smoking increases the risk of miscarriage and should be discouraged. Alcohol consumption exceeding two drinks per day and caffeine consumption exceeding 300 mg/day may increase risk for pregnancy loss and are best avoided. Women who have experienced a miscarriage should be cautioned regarding known environmental toxins. An increased risk of miscarriage is one more reason to vigorously confront obesity ([Chapter 19](#)).

# UNEXPLAINED RECURRENT PREGNANCY LOSS

---

Even after a thorough and systematic evaluation, well more than half of all women with recurrent pregnancy loss have no identified predisposing factors that can explain their poor reproductive history, and the large majority does well in the next pregnancy. Those with a previous second-trimester loss have a poorer prognosis and are at increased risk for preterm delivery, stillbirth, and neonatal death.<sup>53,54,55,56,485,486</sup> Frequent communication, cautious optimism, and emotional support during the first trimester of the next pregnancy have their own distinct therapeutic value.<sup>53</sup> With determined efforts, 70–75% of women with unexplained recurrent pregnancy loss ultimately achieve a successful pregnancy.<sup>6</sup> Careful monitoring is warranted because women with recurrent pregnancy loss are also at increased risk for ectopic pregnancy.<sup>487</sup>

Many clinicians offer or recommend empiric exogenous progesterone supplementation during early pregnancy to women with unexplained recurrent pregnancy loss. Any concerned clinician wants to do all that can be done to improve the chances for a successful pregnancy. Considering that two-thirds or more of next pregnancies among women with unexplained recurrent pregnancy loss are likely to succeed, with or without treatment, it is also easy to understand why so many are also convinced that treatment has value when there is no compelling evidence for its effectiveness.<sup>488,489,490</sup> Low-dose aspirin treatment is another commonly recommended treatment for women with unexplained recurrent early pregnancy loss, even though randomized trials have demonstrated that it has no benefit.<sup>270,361</sup> In the doses commonly administered, exogenous progesterone supplementation and low-dose aspirin pose few risks and are difficult to condemn, but without clear evidence for their effectiveness, neither can be recommended.

# **Summary of Key Facts Relating to Unexplained Recurrent Pregnancy Loss**

**Even thorough evaluation will reveal no evidence for a predisposing factor in more than half of all women with recurrent pregnancy loss. Under such circumstances, the longer term prognosis for achieving a successful pregnancy is very good. Emotional support and careful monitoring during early pregnancy help to improve pregnancy outcomes. Empiric treatments with exogenous progesterone or aspirin in women with unexplained recurrent pregnancy loss have no proven value.**

# Evaluation and Treatment for Recurrent Pregnancy Loss

As a quick reference, the [Table 30.4](#) summarizes our recommended evaluation and treatments for factors known to predispose to recurrent pregnancy loss. **Established tests and treatments are shown in bold type. Tests and treatments that must be applied selectively and those not yet firmly established are shown in standard type.**

## **TABLE 30.4 Recommended Evaluation and Treatment for Recurrent Pregnancy Loss**

<b>Category</b>	<b>Evaluation</b>	<b>Treatments</b>
<b>Genetic</b>	<b>Karyotype, both partners</b> Ovarian reserve test Comparative genomic hybridization	<b>Counseling</b> <b>Donor gametes where appropriate</b> Preimplantation genetic diagnosis
<b>Anatomic</b>	<b>Sonohysterography or HSG</b> Magnetic resonance imaging IVP or renal ultrasound	<b>Hysteroscopic septoplasty</b> <b>Hysteroscopic myomectomy</b> <b>Hysteroscopic adhesiolysis</b> Abdominal metroplasty Abdominal myomectomy Cervical cerclage
<b>Immunologic</b>	<b>Lupus anticoagulant</b> <b>Anticardiolipin antibody</b> <b>Anti-β2-glycoprotein I antibody</b>	<b>Aspirin and heparin</b>
<b>Thrombophilias</b>	Factor V Leiden Prothrombin gene mutation Activated protein C resistance Homocysteine Protein C Protein S Antithrombin III	Heparin
<b>Endocrine</b>	<b>TSH</b> <b>Luteal phase duration</b> Blood glucose, Hgb A1c Prolactin	<b>Thyroxine</b> <b>Clomiphene citrate</b> <b>Metformin</b> <b>Dopamine agonists</b>
<b>Infectious</b>	<b>As indicated by symptoms</b>	Empiric antibiotics
<b>Environmental</b>	<b>History</b>	Behavior modification

# REFERENCES

1. **Malpas P**, A study of abortion sequence, *J Obstet Gynaecol Br Emp* 45:932, 1938.
2. **Eastman NJ**, Habitual abortion, In: Meigs JV, Sturgis S, eds. *Progress in Gynecology*, Vol. 1, Grune & Stratton, New York, 1946.
3. **Warburton D, Fraser FS**, Spontaneous abortion risks in man: data from reproductive histories collected in a medical genetics unit, *Am J Hum Genet* 16:1, 1964.
4. **Poland BJ, Miller JR, Jones DC, Trimble BK**, Reproductive counseling in patients who have had a spontaneous abortion, *Am J Obstet Gynecol* 127:685, 1977.
5. **Roman E**, Fetal loss rates and their relation to pregnancy order, *J Epidemiol Community Health* 38:29, 1984.
6. **Clifford K, Rai R, Regan L**, Future pregnancy outcome in unexplained recurrent first trimester miscarriage, *Hum Reprod* 12:387, 1997.
7. **Stirrat GM**, Recurrent miscarriage, *Lancet* 336:673, 1990.
8. **Lee RM, Silver RM**, Recurrent pregnancy loss: summary and clinical implications, *Semin Reprod Med* 18:433, 2000.
9. **Christiansen OB, Nybo Andersen AM, Bosch E, Daya S, Delves PJ, Hviid TV, Kutteh WH, Laird SM, Li TC, van der Ven K**, Evidence-based investigations and treatments of recurrent pregnancy loss, *Fertil Steril* 83:821, 2005.
10. **Jacobs PA, Hassold TJ**, Chromosomal abnormalities: origin and etiology in abortions and live births, In: Vogel F, Sperling K, eds. *Human Genetics*, Springer-Verlag, Berlin, 1987, p. 233.
11. **Quenby S, Vince G, Farquharson R, Aplin J**, Recurrent miscarriage: a defect in nature's quality control? *Hum Reprod* 17:1959, 2002.
12. **Geller PA, Klier CM, Neugebauer R**, Anxiety disorders following miscarriage, *J Clin Psychiatry* 62:432, 2001.
13. **Neugebauer R, Kline J, Shrout P, Skodol A, O'Connor P, Geller PA, Stein Z, Susser M**, Major depressive disorder in the 6 months after miscarriage, *JAMA* 277:383, 1997.
14. **Gosden RG**, Maternal age: a major factor affecting the prospects and outcome of pregnancy, *Ann N Y Acad Sci* 442:45, 1985.
15. **Wilcox AJ, Weiberg CR, O'Connor JF, Baird DD, Schlatterer JP, Canfield RE, Armstrong EG, Nisula BC**, Incidence of early loss of pregnancy, *N Engl J Med* 319:189, 1988.
16. **Zinaman MJ, Clegg ED, Brown CC, O'Connor J, Selevan SG**, Estimates of human fertility and pregnancy loss, *Fertil Steril* 65:503, 1996.
17. **Edmonds DK, Lindsay KS, Miller JF, Williamson E, Wood PJ**, Early embryonic mortality in women, *Fertil Steril* 38:447, 1982.
18. **Regan L, Braude PR, Trembath PL**, Influence of past reproductive performance on risk of spontaneous abortion, *Br Med J* 299:541, 1989.
19. **Stirrat GM**, Recurrent miscarriage. II: Clinical associations, causes, and management, *Lancet* 336:728, 1990.
20. **Bulletti C, Flamigni C, Giacomucci E**, Reproductive failure due to spontaneous abortion and recurrent miscarriage, *Hum Reprod Update* 2:118, 1996.
21. **Maroulis GB**, Effect of aging on fertility and pregnancy, *Semin Reprod Endocrinol* 9:165, 1991.
22. **Stein ZA**, A woman's age: childbearing and childrearing, *Am J Epidemiol* 121:327, 1985.
23. **Hassold T, Chiu D**, Maternal age-specific rates of numerical chromosome abnormalities with special reference to trisomy, *Hum Genet* 70:11, 1985.
24. **Warburton D, Kline J, Stein Z, Strobino B**, Cytogenetic abnormalities in spontaneous abortions of recognized conceptions, In: Porter IH, ed. *Perinatal Genetics: Diagnosis and Treatment*, Academic Press, New York, 1986, p. 133.
25. **Nybo Andersen AM, Wohlfahrt J, Christens P, Olsen J, Melbye M**, Maternal age and fetal loss: population based register linkage study, *Br Med J* 320:1708, 2000.
26. **Warburton D**, Reproductive loss: how much is preventable? *N Engl J Med* 316:158, 1987.

27. **Goldstein SR**, Embryonic death in early pregnancy: a new look at the first trimester, *Obstet Gynecol* 84:294, 1994.
28. **Simpson JL, Mills JL, Holmes LB, Ober CL, Aarons J, Jovanovic L, Knopp RH**, Low fetal loss rates after ultrasound-proved viability in early pregnancy, *JAMA* 258:2555, 1987.
29. **Rosen GF, Silva PD, Patrizio P, Asch RH, Yee B**, Predicting pregnancy outcome by the observation of a gestational sac or of early fetal cardiac motion with transvaginal ultrasonography, *Fertil Steril* 54:260, 1990.
30. **van Leeuwen I, Branch DW, Scott JR**, First trimester ultrasonography findings in women with a history of recurrent pregnancy loss, *Am J Obstet Gynecol* 168:111, 1993.
31. **Laufer MR, Ecker JL, Hill JA**, Pregnancy outcome following ultrasound-detected fetal cardiac activity in women with a history of multiple spontaneous abortions, *J Soc Gynecol Invest* 1:138, 1994.
32. **Falco P, Milano V, Pilu G, David C, Grisolia G, Rizzo N, Bovicelli L**, Sonography of pregnancies with first-trimester bleeding and a viable embryo: a study of prognostic indicators by logistic regression analysis, *Ultrasound Obstet Gynecol* 7:165, 1996.
33. **Tannirandorn Y, Sangsawang S, Manotaya S, Uerpairojkit B, Samritpradit P, Charoenvidhya D**, Fetal loss in threatened abortion after embryonic/fetal heart activity, *Int J Gynaecol Obstet* 81:263, 2003.
34. **Nagy S, Bush M, Stone J, Lapinski RH, Gardo S**, Clinical significance of subchorionic and retroplacental hematomas detected in the first trimester of pregnancy, *Obstet Gynecol* 102:94, 2003.
35. **Laboda LA, Estroff JA, Benacerraf BR**, First trimester bradycardia. A sign of impending fetal loss, *J Ultrasound Med* 8:561, 1989.
36. **Deaton JL, Honoré GM, Huffman CS, Bauguess P**, Early transvaginal ultrasound following an accurately dated pregnancy: the importance of finding a yolk sac or fetal heart motion, *Hum Reprod* 12:2820, 1997.
37. **Boue J, Boue A, Lazar P**, Retrospective and prospective epidemiological studies of 1500 karyotyped spontaneous human abortions, *Teratology* 12:11, 1975.
38. **Gueneri S, Bettio D, Simoni G, Brambat B, Lanzani A, Fraccaro M**, Prevalence and distribution of chromosome abnormalities in a sample of first-trimester internal abortions, *Hum Reprod* 2:735, 1987.
39. **Simpson JL**, Genes, chromosomes, and reproductive failure, *Fertil Steril* 33:107, 1980.
40. **Goddijn M, Leschot NJ**, Genetic aspects of miscarriage, *Baillieres Best Pract Res Clin Obstet Gynaecol* 14:855, 2000.
41. **Yusuf RZ, Naeem R**, Cytogenetic studies of spontaneous miscarriages: a seven year study to compare significance of primary vs. secondary culture methods for assessment of fetal karyotype yield and maternal cell contamination, *Early Pregnancy* 5:121, 2001.
42. **Lomax B, Tang S, Separovic E, Phillips D, Hillard E, Thomson T, Kalousek DK**, Comparative genomic hybridization in combination with flow cytometry improves results of cytogenetic analysis of spontaneous abortions, *Am J Hum Genet* 66:1516, 2000.
43. **Fritz B, Hallermann C, Olert J, Fuchs B, Bruns M, Aslan M, Schmidt S, Coerdts W, Muntefering H, Rehder H**, Cytogenetic analyses of culture failures by comparative genomic hybridisation (CGH)—re-evaluation of chromosome aberration rates in early spontaneous abortions, *Eur J Hum Genet* 9:539, 2001.
44. **Philipp T, Philipp K, Reiner A, Beer F, Kalousek DK**, Embryoscopic and cytogenetic analysis of 233 missed abortions: factors involved in the pathogenesis of developmental defects of early failed pregnancies, *Hum Reprod* 18:1724, 2003.
45. **Ward KJ**, Genetic factors in recurrent pregnancy loss, *Semin Reprod Med* 18:425, 2000.
46. **Carr DH**, Chromosome studies in selected spontaneous abortions and early pregnancy loss, *Obstet Gynecol* 37:570, 1971.
47. **Stephenson MD, Awartani KA, Robinson WP**, Cytogenetic analysis of miscarriages from couples with recurrent miscarriage: a case-control study, *Hum Reprod* 17:446, 2002.
48. **Stern JJ, Dorfmann AD, Gutierrez-Najar AJ, Cerrillo M, Coulam CB**, Frequency of abnormal karyotypes among abortuses from women with and without a history of recurrent spontaneous abortion, *Fertil Steril* 65:250, 1996.
49. **Ogasawara M, Aoki K, Okada S, Suzumori K**, Embryonic karyotype of abortuses in relation to the number of previous miscarriages, *Fertil Steril* 73:300, 2000.



50. **Carp H, Toder V, Aviram A, Daniely M, Mashlach S, Barkai G**, Karyotype of the abortus in recurrent miscarriage, *Fertil Steril* 75:678, 2001.
51. **Tho PT, Byrd JR, McDonough PG**, Etiologies and subsequent reproductive performance of 100 couples with recurrent abortion, *Fertil Steril* 32:389, 1979.
52. **Harger JH, Archer DF, Marchese SG, Muracca-Clemens M, Garver KL**, Etiology of recurrent pregnancy losses and outcome of subsequent pregnancies, *Obstet Gynecol* 62:574, 1983.
53. **Stray-Pedersen B, Stray-Pedersen S**, Etiologic factors and subsequent reproductive performance in 195 couples with a prior history of habitual abortion, *Am J Obstet Gynecol* 148:140, 1984.
54. **Portnoi M-F, Joye N, van den Akker J, Morlier G, Taillemite JL**, Karyotypes of 1142 couples with recurrent abortion, *Obstet Gynecol* 72:310, 1988.
55. **Plouffe L Jr, White EW, Tho ST, Sweet CS, Layman LC, Whitman GF, McDonough PG**, Etiologic factors of recurrent abortion and subsequent reproductive performance of couples: have we made any progress in the past 10 years? *Am J Obstet Gynecol* 167:313, 1992.
56. **Tulppala M, Palosuo T, Ramsay T, Miettinen A, Salonen R, Ylikorkala O**, A prospective study of 63 couples with a history of recurrent spontaneous abortions: contributing factors and outcome of subsequent pregnancies, *Hum Reprod* 8:7640, 1993.
57. **Fryns JP, Van Buggenhout G**, Structural chromosome rearrangements in couples with recurrent fetal wastage, *Eur J Obstet Gynecol Reprod Biol* 81:171, 1998.
58. **De Braekeleer M, Dao TN**, Cytogenetic studies in couples experiencing repeated pregnancy losses, *Hum Reprod* 5:519, 1990.
59. **Gardner RJM, Sutherland GR**, Autosomal reciprocal translocations. *Chromosome Abnormalities and Genetic Counseling*, Oxford University Press, New York, 1996, p. 59.
60. **Egozcue J, Blanco J, Anton E, Egozcue S, Sarrate Z, Vidal F**, Genetic analysis of sperm and implications of severe male infertility—a review, *Placenta* 24(Suppl 2): S62, 2003.
61. **Shi Q, Ko E, Barclay L, Hoang T, Rademaker A, Martin R**, Cigarette smoking and aneuploidy in human sperm, *Mol Reprod Dev* 59:417, 2001.
62. **Escudero T, Abdelhadi I, Sandalinas M, Munne S**, Predictive value of sperm fluorescence in situ hybridization analysis on the outcome of preimplantation genetic diagnosis for translocations, *Fertil Steril* 79 (Suppl 3):1528, 2003.
63. **Fraccaro M, Lindsten J, Ford CE, Iselius L**, The 11q;22q translocation: a European collaborative analysis of 43 cases, *Hum Genet* 56:21, 1980.
64. **Iselius L, Lindsten J, Aurias A, Fraccaro M, Bastard C, Bottelli AM, Bui TH, Caufin D, Dalpra L, Delendi N, et al.**, The 11q;22q translocation: a collaborative study of 20 new cases and analysis of 110 families, *Hum Genet* 64:343, 1983.
65. **Zackai EH, Emanuel BS**, Site-specific reciprocal translocation, t(11;22) (q23;q11), in several unrelated families with 3:1 meiotic disjunction, *Am J Med Genet* 7:507, 1980.
66. **Teo SH, Tan M, Knight L, Yeo SH, Ng I**, Pericentric inversion 9—incidence and clinical significance, *Ann Acad Med Singapore* 24:302, 1995.
67. **Ferfour F, Clement P, Gomes DM, Minz M, Amar E, Selva J, Vialard F**, Is classic pericentric inversion of chromosome 2 inv(2)(p11q13) associated with an increased risk of unbalanced chromosomes? *Fertil Steril* 92:1497, 2009.
68. **van den Boogaard E, Kaandorp SP, Franssen MT, Mol BW, Leschot NJ, Wouters CH, Van der Veen F, Korevaar JC, Goddijn M**, Consecutive or non-consecutive recurrent miscarriage: is there any difference in carrier status? *Hum Reprod* 25:1411, 2010.
69. **Barratt PJ, Juberg RC, Fritz MA, Holliday DJ**, Fetal death associated with a t(1;14) in three generations, *Am J Med Genet Suppl* 3:157, 1987.
70. **Pellestor F, Andreo B, Arnal F, Humeau C, Demaille J**, Maternal aging and chromosomal abnormalities: new data drawn from in vitro unfertilized human oocytes, *Hum Genet* 112:195, 2003.
71. **Angell R**, Mechanism of chromosome nondisjunction in human oocytes, *Prog Clin Biol Res* 393:13, 1995.
72. **Angell R**, First-meiotic-division nondisjunction in human oocytes, *Am J Hum Genet* 61:23, 1997.

73. **Kuliev A, Cieslak J, Ilkevitch Y, Verlinsky Y**, Chromosomal abnormalities in a series of 6,733 human oocytes in preimplantation diagnosis for age-related aneuploidies, *Reprod Biomed Online* 6:54, 2003.
74. **Nasmyth K**, Disseminating the genome: joining, resolving, and separating sister chromatids during mitosis and meiosis, *Annu Rev Genet* 35:673, 2001.
75. **Battaglia DE, Goodwin P, Klein NA, Soules MR**, Influence of maternal age on meiotic spindle assembly in oocytes from naturally cycling women, *Hum Reprod* 11:2217, 1996.
76. **Volarcik K, Sheean L, Goldfarb J, Woods L, Abdul-Karim FW, Hunt P**, The meiotic competence of in vitro matured human oocytes is influenced by donor age: evidence that folliculogenesis is compromised in the reproductively aged ovary, *Hum Reprod* 13:154, 1998.
77. **Hassold T, Hunt P**, To err (meiotically) is human: the genesis of human aneuploidy, *Nat Rev Genet* 2:280, 2001.
78. **Trout SW, Seifer DB**, Do women with unexplained recurrent pregnancy loss have higher day 3 serum FSH and estradiol values? *Fertil Steril* 74:335, 2000.
79. **Hofmann GE, Khoury J, Thie J**, Recurrent pregnancy loss and diminished ovarian reserve, *Fertil Steril* 74:1192, 2000.
80. **Katz-Jaffe MG, Surrey ES, Minjarez DA, Gustofson RL, Stevens JM, Schoolcraft WB**, Association of abnormal ovarian reserve parameters with a higher incidence of aneuploid blastocysts, *Obstet Gynecol* 121(1):71, 2013. doi:<http://10.1097/AOG.0b013e318278eeda>.
81. **Shahine LK, Marshall L, Lamb JD, Hickok LR**, Higher rates of aneuploidy in blastocysts and higher risk of no embryo transfer in recurrent pregnancy loss patients with diminished ovarian reserve undergoing in vitro fertilization, *Fertil Steril* 106(5):1124, 2016. doi:10.1016/j.fertnstert.2016.06.016.
82. **Morin SJ, Patounakis G, Juneau CR, Neal SA, Scott RT Jr, Seli E**, Diminished ovarian reserve and poor response to stimulation in patients <38 years old: a quantitative but not qualitative reduction in performance, *Hum Reprod*, 2018.
83. **Bishop LA, Richter KS, Patounakis G, Andriani L, Moon K, Devine K**, Diminished ovarian reserve as measured by means of baseline follicle-stimulating hormone and antral follicle count is not associated with pregnancy loss in younger in vitro fertilization patients, *Fertil Steril* 108(6):980, 2017. doi:10.1016/j.fertnstert.2017.09.011.
84. **Treloar AE**, Menstrual cyclicity and the pre-menopause, *Maturitas* 3:249, 1981.
85. **van Noord PAH, Dubas JS, Dorland M, Boersma H, te Velde E**, Age at natural menopause in a population-based screening cohort: the role of menarche, fecundity, and lifestyle factors, *Fertil Steril* 68:95, 1997.
86. **Tibiletti MG, Testa G, Vegetti W, Alagna F, Taborelli M, Dalpra L, Bolis PF, Crosignani PG**, The idiopathic forms of premature menopause and early menopause show the same genetic pattern, *Hum Reprod* 14:2731, 1999.
87. **Vegetti W, Marozzi A, Manfredini E, Testa G, Alagna F, Nicolosi A, Caliari I, Taborelli M, Tibiletti MG, Dalpra L, Crosignani PG**, Premature ovarian failure, *Mol Cell Endocrinol* 161:53, 2000.
88. **Nikolaou D, Templeton A**, Early ovarian ageing: a hypothesis: detection and clinical relevance, *Hum Reprod* 18:1137, 2003.
89. **Kline J, Kinney A, Levin B, Warburton D**, Trisomic pregnancy and earlier age at menopause, *Am J Hum Genet* 67:395, 2000.
90. **Nasser A, Mukherjee T, Grifo JA, Noyes N, Krey L, Copperman AB**, Elevated day 3 serum follicle stimulating hormone and/or estradiol may predict fetal aneuploidy, *Fertil Steril* 71:715, 1999.
91. **van Beresteijn ECH, Korevaar JC, Huijbregts PCW, Schouten EG, Burema J, Kok FJ**, Perimenopausal increase in serum cholesterol: a 10-year longitudinal study, *Am J Epidemiol* 137:383, 1993.
92. **van Montfrans JM, Dorland M, Oosterhuis GJ, van Vugt JM, Rekers-Mombarg LT, Lambalk CB**, Increased concentrations of follicle-stimulating hormone in mothers of children with Down's syndrome, *Lancet* 353:1853, 1999.
93. **van Montfrans JM, van Hooff MH, Martens F, Lambalk CB**, Basal FSH, estradiol and inhibin B concentrations in women with a previous Down's syndrome affected pregnancy, *Hum Reprod* 17:44, 2002.

94. **Freeman SB, Yang Q, Allran K, Taft LF, Sherman SL**, Women with a reduced ovarian complement may have an increased risk for a child with Down syndrome, *Am J Hum Genet* 66:1680, 2000.
95. **Sangha KK, Stephenson MD, Brown CJ, Robinson WP**, Extremely skewed X-chromosome inactivation is increased in women with recurrent spontaneous abortion, *Am J Hum Genet* 65:913, 1999.
96. **Lanasa MC, Hogge WA**, X chromosome defects as an etiology of recurrent spontaneous abortion, *Semin Reprod Med* 18:97, 2000.
97. **Uehara S, Hashiyada M, Sato K, Sato Y, Fujimori K, Okamura K**, Preferential X-chromosome inactivation in women with idiopathic recurrent pregnancy loss, *Fertil Steril* 76:908, 2001.
98. **Beever CL, Stephenson MD, Penaherrera MS, Jiang RH, Kalousek DK, Hayden M, Field L, Brown CJ, Robinson WP**, Skewed X-chromosome inactivation is associated with trisomy in women ascertained on the basis of recurrent spontaneous abortion or chromosomally abnormal pregnancies, *Am J Hum Genet* 72:399, 2003.
99. **Bagislar S, Ustuner I, Cengiz B, Soylemiez F, Akyerli CB, Ceylaner S, Ceylaner G, Acar A, Ozelik T**, Extremely skewed X-chromosome inactivation patterns in women with recurrent spontaneous abortion, *Aust N Z J Obstet Gynaecol* 46:384, 2006.
100. **Hogge WA, Prosen TL, Lanasa MC, Huber HA, Reeves MF**, Recurrent spontaneous abortion and skewed X-inactivation: is there an association? *Am J Obstet Gynecol* 384:e1, 2007.
101. **Warburton D, Kline J, Kinney A, Yu CY, Levin B, Brown S**, Skewed X chromosome inactivation and trisomic spontaneous abortion: no association, *Am J Hum Genet* 85:179, 2009.
102. **Lanasa MC, Hogge WA, Kubik CJ, Ness RB, Harger J, Nagel T, Prosen T, Markovic N, Hoffman EP**, A novel X chromosome-linked genetic cause of recurrent spontaneous abortion, *Am J Obstet Gynecol* 185:563, 2001.
103. **Simpson JL, Rajkovic A**, Ovarian differentiation and gonadal failure, *Am J Med Genet* 89:186, 1999.
104. **Carrell DT, Wilcox AL, Lowy L, Peterson CM, Jones KP, Erickson L, Campbell B, Branch DW, Hatasaka HH**, Elevated sperm chromosome aneuploidy and apoptosis in patients with unexplained recurrent pregnancy loss, *Obstet Gynecol* 101:1229, 2003.
105. **Rubio C, Simon C, Blanco J, Vidal F, Minguez Y, Egozcue J, Crespo J, Remohi J, Pellicer A**, Implications of sperm chromosome abnormalities in recurrent miscarriage, *J Assist Reprod Genet* 16:253, 1999.
106. **Egozcue S, Blanco J, Vendrell JM, Garcia F, Veiga A, Aran B, Barri PN, Vidal F, Egozcue J**, Human male infertility: chromosome anomalies, meiotic disorders, abnormal spermatozoa and recurrent abortion, *Hum Reprod Update* 6:93, 2000.
107. **Shi Q, Martin RH**, Aneuploidy in human spermatozoa: FISH analysis in men with constitutional chromosomal abnormalities, and in infertile men, *Reproduction* 121:655, 2001.
108. **Pfeffer J, Pang MG, Hoegerman SF, Osgood CJ, Stacey MW, Mayer J, Oehninger S, Kearns WG**, Aneuploidy frequencies in semen fractions from ten oligoasthenoteratozoospermic patients donating sperm for intracytoplasmic sperm injection, *Fertil Steril* 72:472, 1999.
109. **Saxena P, Misro MM, Chaki SP, Chopra K, Roy S, Nandan D**, Is abnormal sperm function an indicator among couples with recurrent pregnancy loss? *Fertil Steril* 90:1854, 2008.
110. **Collodel G, Giannerini V, Antonio Pascarelli N, Federico MG, Comodo F, Moretti E**, TEM and FISH studies in sperm from men of couples with recurrent pregnant loss, *Andrologia* 41:352, 2009.
111. **Bhattacharya SM**, Hypo-osmotic swelling test and unexplained repeat early pregnancy loss, *J Obstet Gynaecol Res* 36:119, 2010.
112. **Shi Q, Martin RH**, Aneuploidy in human sperm: a review of the frequency and distribution of aneuploidy, effects of donor age and lifestyle factors, *Cytogenet Cell Genet* 90:219, 2000.
113. **Slama R, Werwatz A, Boutou O, Ducot B, Spira A, Hardle W**, Does male age affect the risk of spontaneous abortion? An approach using semiparametric regression, *Am J Epidemiol* 157:815, 2003.
114. **Levy B, Sigurjonsson S, Pettersen B, Maisenbacher MK, Hall MP, Demko Z, Lathi RB, Tao R, Aggarwal V, Rabinowitz M**, Genomic imbalance in products of conception: single-nucleotide polymorphism chromosomal microarray analysis, *Obstet Gynecol* 124(2 Pt 1):202, 2014.
115. **Bagheri H, Mercier E, Qiao Y, Stephenson MD, Rajcan-Separovic E**, Genomic characteristics of

miscarriage copy number variants, *Mol Hum Reprod* 21(8):655, 2015.

116. **Levi AJ, Raynault MF, Bergh PA, Drews MR, Miller BT, Scott RT Jr**, Reproductive outcome in patients with diminished ovarian reserve, *Fertil Steril* 76:666, 2001.
117. **Franssen MT, Korevaar JC, van der Veen F, Leschot NJ, Bossuyt PM, Goddijn M**, Reproductive outcome after chromosome analysis in couples with two or more miscarriages: index (corrected)-control study, *Br Med J* 332:759, 2006.
118. **Verlinsky Y, Ginsberg N, Lifchez A, Valle J, Moise J, Strom CM**, Analysis of the first polar body: preconception genetic diagnosis, *Hum Reprod* 5:826, 1990.
119. **Handyside AH, Lesko JG, Tarin JJ, Winston RML, Hughes MR**, Birth of a normal girl after in vitro fertilization and preimplantation diagnostic testing for cystic fibrosis, *N Engl J Med* 327:905, 1992.
120. **Handyside AH, Kontogianni EH, Hardy K, Winston RM**, Pregnancies from biopsied human preimplantation embryos sexed by Y-specific DNA amplification, *Nature* 344:768, 1990.
121. **Gianaroli L, Magli MC, Fiorentino F, Baldi M, Ferraretti AP**, Clinical value of preimplantation genetic diagnosis, *Placenta* 24(Suppl 2):S77, 2003.
122. **Voullaire L, Slater H, Williamson R, Wilton L**, Chromosome analysis of blastomeres from human embryos by using comparative genomic hybridization, *Hum Genet* 106:210, 2000.
123. **Wilton L, Voullaire L, Sargeant P, Williamson R, McBain J**, Preimplantation aneuploidy screening using comparative genomic hybridization or fluorescence in situ hybridization of embryos from patients with recurrent implantation failure, *Fertil Steril* 80:860, 2003.
124. **Wilton L, Williamson R, McBain J, Edgar D, Voullaire L**, Birth of a healthy infant after preimplantation confirmation of euploidy by comparative genomic hybridization, *N Engl J Med* 345:1537, 2001.
125. **Menten B, Swerts K, Delle Chiaie B, Janssens S, Buysse K, Phillippe J, Speleman F**, Array comparative genomic hybridization and flow cytometry analysis of spontaneous abortions and mors in utero samples, *BMC Med Genet* 10:89, 2009.
126. **Warren JE, Turok DK, Maxwell TM, Brothman AR, Silver RM**, Array comparative genomic hybridization for genetic evaluation of fetal loss between 10 and 20 weeks of gestation, *Obstet Gynecol* 114:1093, 2009.
127. **Maxwell SM, Colls P, Hodes-Wertz B, McCulloh DH, McCaffrey C, Wells D, et al.**, Why do euploid embryos miscarry? A case-control study comparing the rate of aneuploidy within presumed euploid embryos that resulted in miscarriage or live birth using next-generation sequencing, *Fertil Steril* 106:1414, 2016.
128. **Munné S, Blazek J, Large M, Martinez-Ortiz PA, Nisson H, Liu E, et al.**, Detailed investigation into the cytogenetic constitution and pregnancy outcome of replacing mosaic blastocysts detected with the use of high-resolution next-generation sequencing, *Fertil Steril* 108:62, 2017.
129. **Friedenthal J, Nybo Andersen AM, Bosch E, Daya S, Delves PJ, Hviid TV, Kutteh WH, Laird SM, Li TC, van der Ven K**, Next generation sequencing for preimplantation genetic screening improves pregnancy outcomes compared with array comparative genomic hybridization in single thawed euploid embryo transfer cycles, *Fertil Steril* 109:627, 2018. doi:10.1016/j.fertnstert.2017.12.017.
130. **Bielanska M, Tan SL, Ao A**, Chromosomal mosaicism throughout human preimplantation development in vitro: incidence, type, and relevance to embryo outcome, *Hum Reprod* 17:413, 2002.
131. **Ruangvutilert P, Delhanty JD, Serhal P, Simopoulou M, Rodeck CH, Harper JC**, FISH analysis on day 5 post-insemination of human arrested and blastocyst stage embryos, *Prenat Diagn* 20:552, 2000.
132. **Gonzalez-Merino E, Emiliani S, Vassart G, Van den Bergh M, Vannin AS, Abramowicz M, Delneste D, Englert Y**, Incidence of chromosomal mosaicism in human embryos at different developmental stages analyzed by fluorescence in situ hybridization, *Genet Test* 7:85, 2003.
133. **Magli MC, Jones GM, Gras L, Gianaroli L, Korman I, Trounson AO**, Chromosome mosaicism in day 3 aneuploid embryos that develop to morphologically normal blastocysts in vitro, *Hum Reprod* 15:1781, 2000.
134. **Munné S, Wells D**, Detection of mosaicism at blastocyst stage with the use of high-resolution next-generation sequencing, *Fertil Steril* 107:1085, 2017.
135. **Taylor TH, Gitlin SA, Patrick JL, Crain JL, Wilson JM, Griffin DK**, The origin, mechanisms, incidence and clinical consequences of chromosomal mosaicism in humans, *Hum Reprod Update* 20:571, 2014.

136. **Munné S, Velilla E, Colls P, Garcia Bermudez M, Vemuri MC, Steuerwald N, et al.**, Self-correction of chromosomally abnormal embryos in culture and implications for stem cell production, *Fertil Steril* 84:1328, 2005.
137. **Besser AG, Mounts EL**, Counselling considerations for chromosomal mosaicism detected by preimplantation genetic screening, *Reprod Biomed Online* 34:369, 2017.
138. **Munne S**, Preimplantation genetic diagnosis and human implantation—a review, *Placenta* 24(Suppl 2):S70, 2003.
139. **Fragouli E, Alfarawati S, Daphnis DD, Goodall NN, Mania A, Griffiths T, et al.**, Cytogenetic analysis of human blastocysts with the use of FISH, CGH and array-CGH: scientific data and technical evaluation, *Hum Reprod* 26:480, 2011.
140. **Greco E, Minasi MG, Fiorentino F**, Healthy babies born after intrauterine transfer of mosaic aneuploid blastocyst, *N Engl J Med* 373:2089, 2015.
141. **Mamas T, Gordon A, Brown A, Harper J, Sengupta S**, Detection of aneuploidy by array comparative genomic hybridization using cell lines to mimic a mosaic trophoctoderm biopsy, *Fertil Steril* 97:943, 2012.
142. **Vera-Rodriguez M, Michel CE, Mercader A, Bladon AJ, Rodrigo L, Kokocinski F, et al.**, Distribution patterns of segmental aneuploidies in human blastocysts identified by next-generation sequencing, *Fertil Steril* 105: 1047, 2016.
143. **Gleicher N, Vidali A, Braverman J, Kushnir VA, Barad DH, Hudson C, Wu YG, Wang Q, Zhang L, Albertini DF; International PGS Consortium Study Group**, Accuracy of preimplantation genetic screening (PGS) is compromised by degree of mosaicism of human embryos, *Reprod Biol Endocrinol* 14(1): 54, 2016.
144. **Spinella F, Fiorentino F, Biricik A, Bono S, Ruberti A, Cotroneo E, Baldi M, Cursio E, Minasi MG, Greco E**, Extent of chromosomal mosaicism influences the clinical outcome of in vitro fertilization treatments, *Fertil Steril* 109(1):77, 2018.
145. **Kushnir VA, Darmon SK, Barad DH, Gleicher N**, Degree of mosaicism in trophoctoderm does not predict pregnancy potential: a corrected analysis of pregnancy outcomes following transfer of mosaic embryos, *Reprod Biol Endocrinol* 16(1):6, 2018. doi:10.1186/s12958-018-0322-5.
146. **Gianaroli L, Magli MC, Ferraretti AP**, The in vivo and in vitro efficiency and efficacy of PGD for aneuploidy, *Mol Cell Endocrinol* 183(Suppl 1):S13, 2001.
147. **Magli MC, Gianaroli L, Ferraretti AP**, Chromosomal abnormalities in embryos, *Mol Cell Endocrinol* 183(Suppl 1):S29, 2001.
148. **Magli MC, Gianaroli L, Munne S, Ferraretti AP**, Incidence of chromosomal abnormalities from a morphologically normal cohort of embryos in poor-prognosis patients, *J Assist Reprod Genet* 15:297, 1998.
149. **Delhanty JD, Harper JC, Ao A, Handyside AH, Winston RM**, Multicolour FISH detects frequent chromosomal mosaicism and chaotic division in normal preimplantation embryos from fertile patients, *Hum Genet* 99:755, 1997.
150. **Simon C, Rubio C, Vidal F, Gimenez C, Moreno C, Parrilla JJ, Pellicer A**, Increased chromosome abnormalities in human preimplantation embryos after in-vitro fertilization in patients with recurrent miscarriage, *Reprod Fertil Dev* 10:87, 1998.
151. **Vidal F, Gimenez C, Rubio C, Simon C, Pellicer A, Santalo J, Egozcue J**, FISH preimplantation diagnosis of chromosome aneuploidy in recurrent pregnancy wastage, *J Assist Reprod Genet* 15:310, 1998.
152. **Pellicer A, Rubio C, Vidal F, Minguez Y, Gimenez C, Egozcue J, Remohi J, Simon C**, In vitro fertilization plus preimplantation genetic diagnosis in patients with recurrent miscarriage: an analysis of chromosome abnormalities in human preimplantation embryos, *Fertil Steril* 71:1033, 1999.
153. **Pehlivan T, Rubio C, Rodrigo L, Remohi J, Pellicer A, Simon C**, Preimplantation genetic diagnosis by fluorescence in situ hybridization: clinical possibilities and pitfalls, *J Soc Gynecol Investig* 10:315, 2003.
154. **Rubio C, Simon C, Vidal F, Rodrigo L, Pehlivan T, Remohi J, Pellicer A**, Chromosomal abnormalities and embryo development in recurrent miscarriage couples, *Hum Reprod* 18:182, 2003.
155. **Gianaroli L, Magli MC, Ferraretti AP, Tabanelli C, Trombetta C, Boudjema E**, The role of preimplantation diagnosis for aneuploidies, *Reprod Biomed Online* 4(Suppl 3):31, 2002.

156. **Gianaroli L, Magli MC, Ferraretti AP, Munne S**, Preimplantation diagnosis for aneuploidies in patients undergoing in vitro fertilization with a poor prognosis: identification of the categories for which it should be proposed, *Fertil Steril* 72:837, 1999.
157. **Murugappan G, Ohno MS, Lathi RB**, Cost-effectiveness analysis of preimplantation genetic screening and in vitro fertilization versus expectant management in patients with unexplained recurrent pregnancy loss, *Fertil Steril* 103(5):1215, 2015. doi:org/10.1016/j.fertnstert.2015.02.012.
158. **Mersereau JE, Plunkett BA, Cedars MI**, Preimplantation genetic screening in older women: a cost-effectiveness analysis, *Fertil Steril* 90:592, 2008.
159. **Munne S, Fung J, Cassel MJ, Marquez C, Weier HU**, Preimplantation genetic analysis of translocations: case-specific probes for interphase cell analysis, *Hum Genet* 102:663, 1998.
160. **Munne S, Magli C, Bahce M, Fung J, Legator M, Morrison L, Cohert J, Gianaroli L**, Preimplantation diagnosis of the aneuploidies most commonly found in spontaneous abortions and live births: XY, 13, 14, 15, 16, 18, 21, 22, *Prenat Diagn* 18:1459, 1998.
161. **Munne S, Sandalinas M, Escudero T, Fung J, Gianaroli L, Cohen J**, Outcome of preimplantation genetic diagnosis of translocations, *Fertil Steril* 73: 1209, 2000.
162. **Otani T, Roche M, Mizuike M, Colls P, Escudero T, Munné S**, Preimplantation genetic diagnosis significantly improves the pregnancy outcome of translocation carriers with a history of recurrent miscarriage and unsuccessful pregnancies, *Reprod Biomed Online* 13:869, 2006.
163. **Garrisi JG, Colls P, Ferry KM, Zheng X, Garrisi MG, Munné S**, Effect of infertility, maternal age, and number of previous miscarriages on the outcome of preimplantation genetic diagnosis for idiopathic recurrent pregnancy loss, *Fertil Steril* 92:288, 2009.
164. **Fischer J, Colls P, Escudero T, Munné S**, Preimplantation genetic diagnosis (PGD) improves pregnancy outcome for translocation carriers with a history of recurrent losses, *Fertil Steril* 94:283, 2010.
165. **Homer HA, Li TC, Cooke ID**, The septate uterus: a review of management and reproductive outcome, *Fertil Steril* 73:1, 2000.
166. **Pellerito JS, McCarthy SM, Doyle MB, Glickman MG, DeCherney AH**, Diagnosis of uterine anomalies: relative accuracy of MR imaging, endovaginal sonography, and hysterosalpingography, *Genitourin Radiol* 183:795, 1992.
167. **Kelly SM, Sladkevicius P, Campbell S, Nargund G**, Investigation of the infertile couple: a one-stop ultrasound-based approach, *Hum Reprod* 16:2481, 2001.
168. **Becker E Jr, Lev-Toaff AS, Kaufman EP, Halpern EJ, Edelweiss MI, Kurtz AB**, The added value of transvaginal sonohysterography over transvaginal sonography alone in women with known or suspected leiomyoma, *J Ultrasound Med* 21:237, 2002.
169. **Leone FP, Lanzani C, Ferrazzi E**, Use of strict sonohysterographic methods for preoperative assessment of submucous myomas, *Fertil Steril* 79:998, 2003.
170. **Sylvestre C, Child TJ, Tulandi T, Tan SL**, A prospective study to evaluate the efficacy of two- and three-dimensional sonohysterography in women with intrauterine lesions, *Fertil Steril* 79:1222, 2003.
171. **Soares SR, Barbosa dos Reis MM, Camargos AF**, Diagnostic accuracy of sonohysterography, transvaginal sonography, and hysterosalpingography in patients with uterine cavity diseases, *Fertil Steril* 73:406, 2000.
172. **Fedele L, Bianchi S, Dorta M, Vignali M**, Intrauterine adhesions: detection with transvaginal US, *Radiology* 199:757, 1996.
173. **Salle B, Gaucherand P, de Saint Hilaire P, Rudigoz RC**, Transvaginal sonohysterographic evaluation of intrauterine adhesions, *J Clin Ultrasound* 27:131, 1999.
174. **Saleem SN**, MR imaging diagnosis of uterovaginal anomalies: current state of the art, *Radiographics* 23:13, 2003.
175. **Ghi T, Casadio P, Kuleva M, Perrone AM, Savelli L, Giunchi S, Meriggiola MC, Gubbini G, Pilu G, Pelusi C, Pelusi G**, Accuracy of three-dimensional ultrasound in diagnosis and classification of congenital uterine anomalies, *Fertil Steril* 92:808, 2009.
176. **Salim R, Regan L, Woelfer B, Backos M, Jurkovic D**, A comparative study of the morphology of

congenital uterine anomalies in women with and without a history of recurrent first trimester miscarriage, *Hum Reprod* 18:162, 2003.

177. **Clifford K, Rai R, Watson H, Regan L**, An informative protocol for the investigation of recurrent miscarriage: preliminary experience of 500 consecutive cases, *Hum Reprod* 9:1328, 1994.
178. **Makino T, Umeuchi M, Nakada K, Nozawa S, Iizuka R**, Incidence of congenital uterine anomalies in repeated reproductive wastage and prognosis for pregnancy after metroplasty, *Int J Fertil* 37:167, 1992.
179. **Makino T, Hara T, Oka C, Toyoshima K, Sugi T, Iwasaki K, Umeuchi M, Iizuka R**, Survey of 1120 Japanese women with a history of recurrent spontaneous abortions, *Eur J Obstet Gynecol Reprod Biol* 44:123, 1992.
180. **Jurkovic D, Gruboeck K, Tailor A, Nicolaides KH**, Ultrasound screening for congenital uterine anomalies, *Br J Obstet Gynaecol* 104:1320, 1997.
181. **Ashton D, Amin HK, Richart RM, Neuwirth RS**, The incidence of asymptomatic uterine anomalies in women undergoing transcervical tubal sterilization, *Obstet Gynecol* 72:28, 1988.
182. **Simon C, Martinez L, Pardo F, Tortajada M, Pellicer A**, Mullerian defects in women with normal reproductive outcome, *Fertil Steril* 56:1192, 1991.
183. **Saravelos SH, Cocksedge KA, Li TC**, The pattern of pregnancy loss in women with congenital uterine anomalies and recurrent miscarriage, *Reprod Biomed Online* 20:416, 2010.
184. **Bohlmann MK, von Wolff M, Luedders DW, Beuter-Winkler P, Diedrich K, Hornemann A, Strowitzki T**, Hysteroscopic findings in women with two and with more than two first-trimester miscarriages are not significantly different, *Reprod Biomed Online* 21:230, 2010.
185. **Leible S, Munoz H, Walton R, Sabaj V, Cumsille F, Sepulveda W**, Uterine artery blood flow velocity waveforms in pregnant women with mullerian duct anomaly: a biologic model for uteroplacental insufficiency, *Am J Obstet Gynecol* 178:1048, 1998.
186. **Propst AM, Hill JA III**, Anatomic factors associated with recurrent pregnancy loss, *Semin Reprod Med* 18:341, 2000.
187. **Heinonen PK**, Unicornuate uterus and rudimentary horn, *Fertil Steril* 68:224, 1997.
188. **Sarto GE, Simpson JL**, Abnormalities of the Mullerian and Wolffian duct systems, *Birth Defects Orig Artic Ser* 14:37, 1978.
189. **Steinberg W**, Strassmann's metroplasty in the management of bipartite uterus causing sterility or habitual abortion, *Obstet Gynecol Surv* 10:400, 1955.
190. **Heinonen PK, Saarikoski S, Pystynen P**, Reproductive performance of women with uterine anomalies. An evaluation of 182 cases, *Acta Obstet Gynecol Scand* 61:157, 1982.
191. **Strassman EO**, Fertility and unification of the pregnant uterus, *Fertil Steril* 17:165, 1966.
192. **Patton PE, Novy MJ**, Reproductive potential of the anomalous uterus, *Semin Reprod Endocrinol* 6:217, 1988.
193. **Golan A, Langer R, Wexler S, Segev E, Niv D, David MP**, Cervical cerclage—its role in the pregnant anomalous uterus, *Int J Fertil* 35:164, 1990.
194. **Blum M**, Prevention of spontaneous abortion by cervical suture of the malformed uterus, *Int Surg* 62:213, 1977.
195. **Raga F, Bauset C, Remohi J, Bonilla-Musoles F, Simón C, Pellicer A**, Reproductive impact of congenital Müllerian anomalies, *Hum Reprod* 12:2277, 1997.
196. **Grimbizis GF, Camus M, Tarlatzis BC, Bontis JN, Devroey P**, Clinical implications of uterine malformations and hysteroscopic treatment results, *Hum Reprod Update* 7:161, 2001.
197. **Burchell RC, Creed F, Rasoulpour M, Whitcomb M**, Vascular anatomy of the human uterus and pregnancy wastage, *Br J Obstet Gynaecol* 85:698, 1978.
198. **Dabirashrafi H, Bahadori M, Mohammad K, Alavi M, Moghadami-Tabrizi N, Zandinejad K, Ghafari V**, Septate uterus: new idea on the histologic features of the septum in this abnormal uterus, *Am J Obstet Gynecol* 172:105, 1995.
199. **Candiani GB, Fedele L, Zamberletti D, De Virgiliis D, Carinelli S**, Endometrial patterns in malformed uteri, *Acta Eur Fertil* 14:311, 1983.
200. **Fedele L, Bianchi S, Marchini M, Mezzopane R, Di Nola G, Tozzi L**, Residual uterine septum of less than

1 cm after hysteroscopic metroplasty does not impair reproductive outcome, *Hum Reprod* 11:727, 1996.

201. **Kaufman RH, Adan E, Binder GL, Gerthoffer E**, Upper genital tract changes and pregnancy outcome in offspring exposed in utero to diethylstilbestrol, *Am J Obstet Gynecol* 137:299, 1980.
202. **Herbst AL, Ulfelder H, Poskanzer DC**, Adenocarcinoma of the vagina. Association of maternal stilbestrol therapy with tumor appearance in young women, *N Engl J Med* 284:878, 1971.
203. **Goldberg JM, Falcone T**, Effect of diethylstilbestrol on reproductive function, *Fertil Steril* 72:1, 1999.
204. **Ludmir J, Landon MB, Gabbe SG, Samuels P, Mennuti MT**, Management of the diethylstilbestrol-exposed pregnant patient: a prospective study, *Am J Obstet Gynecol* 157:665, 1987.
205. **Levine RU, Berkowitz KM**, Conservative management and pregnancy outcome in diethylstilbestrol-exposed women with and without gross genital tract abnormalities, *Am J Obstet Gynecol* 169:1125, 1993.
206. **Buttram VC, Reiter RC**, Uterine leiomyomata: etiology, symptomatology and management, *Fertil Steril* 36:433, 1981.
207. **Li TC, Mortimer R, Cooke ID**, Myomectomy: a retrospective study to examine reproductive performance before and after surgery, *Hum Reprod* 14:1735, 1999.
208. **Bosteels J, Kasius J, Weyers S, Broekmans FJ, Mol BW, D'Hooghe TM**, Hysteroscopy for treating subfertility associated with suspected major uterine cavity abnormalities, *Cochrane Database Syst Rev* (2):CD009461, 2015. doi:10.1002/14651858.CD009461.pub3. Review.
209. **Vollenhoven BJ, Lawrence AS, Healy DL**, Uterine fibroids: a clinical review, *Br J Obstet Gynaecol* 97:285, 1990.
210. **Tal R, Segars JH**, The role of angiogenic factors in fibroid pathogenesis: potential implications for future therapy, *Hum Reprod Update* 20(2):194, 2014. doi:10.1093/humupd/dmt042. Review.
211. **Doherty LF, Taylor HS**, Leiomyoma-derived transforming growth factor- $\beta$  impairs bone morphogenetic protein-2-mediated endometrial receptivity, *Fertil Steril* 103(3):845, 2015.
212. **Sinclair DC, Mastroyannis A, Taylor HS**, Leiomyoma simultaneously impair endometrial BMP-2-mediated decidualization and anticoagulant expression through secretion of TGF- $\beta$ 3, *J Clin Endocrinol Metab* 96(2):412, 2011.
213. **Styer AK, Jin S, Liu D, Wang B, Polotsky AJ, Christianson MS, Vitek W, Engmann L, Hansen K, Wild R, Legro RS, Coutifaris C, Alvero R, Robinson RD, Casson P, Christman GM, Christy A, Diamond MP, Eisenberg E, Zhang H, Santoro N; National Institute of Child Health and Human Development Reproductive Medicine Network**, Association of uterine fibroids and pregnancy outcomes after ovarian stimulation-intrauterine insemination for unexplained infertility, *Fertil Steril* 107(3):756, 2017.
214. **Farhi J, Ashkenazi J, Feldberg D, Dicker D, Orvieto R, Ben Rafael Z**, Effect of uterine leiomyomata on the results of in-vitro fertilization treatment, *Hum Reprod* 10:2576, 1995.
215. **Ramzy AM, Sattar M, Amin Y, Mansour RT, Serour GI, Aboulghar MA**, Uterine myomata and outcome of assisted reproduction, *Hum Reprod* 13:198, 1998.
216. **Jun SH, Ginsburg ES, Racowsky C, Wise LA, Hornstein MD**, Uterine leiomyomas and their effect on in vitro fertilization outcome: a retrospective study, *J Assist Reprod Genet* 18:139, 2001.
217. **Surrey ES, Lietz AK, Schoolcraft WB**, Impact of intramural leiomyomata in patients with a normal endometrial cavity on in vitro fertilization-embryo transfer cycle outcome, *Fertil Steril* 75:405, 2001.
218. **Pritts EA, Parker WH, Olive DL**, Fibroids and infertility: an updated systematic review of the evidence, *Fertil Steril* 91(4):1215, 2009. doi:10.1016/j.fertnstert.2008.01.051. Epub 2008 Mar 12. Review.
219. **Goldenberg M, Sivan E, Sharabi Z, Bider D, Rabinovici J, Seidman DS**, Outcome of hysteroscopic resection of submucous myomas for infertility, *Fertil Steril* 64:714, 1995.
220. **Giatras K, Berkeley AS, Noyes N, Licciardi F, Lolis D, Grifo JA**, Fertility after hysteroscopic resection of submucous myomas, *J Am Assoc Gynecol Laparosc* 6:155, 1999.
221. **Varasteh NN, Neuwirth RS, Levin B, Keltz MD**, Pregnancy rates after hysteroscopic polypectomy and myomectomy in infertile women, *Obstet Gynecol* 94:168, 1999.
222. **Vercellini P, Maddalena S, De Giorgi O, Pesole A, Ferrari L, Crosignani PG**, Determinants of reproductive outcome after abdominal myomectomy for infertility, *Fertil Steril* 72:109, 1999.
223. **Fernandez H, Sefrioui O, Virelizier C, Gervaise A, Gomel V, Frydman R**, Hysteroscopic resection of



- submucosal myomas in patients with infertility, *Hum Reprod* 16:1489, 2001.
224. **March CM**, Intrauterine adhesions, *Obstet Gynecol Clin North Am* 22:491, 1995.
  225. **Al-Inany H**, Intrauterine adhesions. An update, *Acta Obstet Gynecol Scand* 80:986, 2001.
  226. **Schenker JG, Margalioth EJ**, Intrauterine adhesions: an updated appraisal, *Fertil Steril* 37:593, 1982.
  227. **Jensen PA, Stromme WB**, Amenorrhea secondary to puerperal curettage (Asherman's syndrome), *Am J Obstet Gynecol* 113:150, 1972.
  228. **Feng ZC, Yang B, Shao J, Liu S**, Diagnostic and therapeutic hysteroscopy for traumatic intrauterine adhesions after induced abortions: clinical analysis of 365 cases, *Gynaecol Endosc* 8:95, 1999.
  229. **Pistofidis GA, Dimitropoulos K, Mastrominas M**, Comparison of operative and fertility outcome between groups of women with intrauterine adhesions after adhesiolysis, *J Am Assoc Gynecol Laparosc* 3(Suppl):S40, 1996.
  230. **Shaffer W**, Role of uterine adhesions in the cause of multiple pregnancy losses, *Clin Obstet Gynecol* 29:912, 1986.
  231. **Goldenberg M, Sivan E, Sharabi Z, Mashiach S, Lipitz S, Seidman DS**, Reproductive outcome following hysteroscopic management of intrauterine septum and adhesions, *Hum Reprod* 10:2663, 1995.
  232. **Petri M, Allbritton J**, Fetal outcome of lupus pregnancy: a retrospective case-control study of the Hopkins Lupus Cohort, *J Rheumatol* 20:650, 1993.
  233. **Fausett MB, Branch DW**, Autoimmunity and pregnancy loss, *Semin Reprod Endocrinol* 18:379, 2000.
  234. **Ginsberg JS, Brill-Edwards P, Johnston M, Denburg JA, Andrew M, Burrows RF, Bensen W, Cividino A, Long AA**, Relationship of antiphospholipid antibodies to pregnancy loss in patients with systemic lupus erythematosus: a cross-sectional study, *Blood* 80:975, 1992.
  235. **Lockshin MD, Druzin ML, Goei S, Qamar T, Magid MS, Jovanovic L, Ferenc M**, Antibody to cardiolipin as a predictor of fetal distress or death in pregnant patients with systemic lupus erythematosus, *N Engl J Med* 313:152, 1985.
  236. **Ogasawara M, Aoki K, Hayashi Y**, A prospective study on pregnancy risk of antiphospholipid antibodies in association with systemic lupus erythematosus, *J Reprod Immunol* 28:159, 1995.
  237. **Kleinman D, Katz VL, Kuller JA**, Perinatal outcomes in women with systemic lupus erythematosus, *J Perinatol* 18:178, 1998.
  238. **Buchanan NM, Khamashta MA, Morton KE, Kerslake S, Baguley EA, Hughes GR**, A study of 100 high risk lupus pregnancies, *Am J Reprod Immunol* 28:192, 1992.
  239. **Wilson WA, Gharavi AE, Koike T, Lockshin MD, Branch DW, Piette JC, Brey R, Derksen R, Harris EN, Hughes GR, Triplett DA, Khamashta MA**, International consensus statement on preliminary classification criteria for definite antiphospholipid syndrome: report of an international workshop, *Arthritis Rheum* 42:1309, 1999.
  240. **Lockshin MD, Sammaritano LR, Schwartzman S**, Validation of the Sapporo criteria for antiphospholipid syndrome, *Arthritis Rheum* 43:440, 2000.
  241. **Triplett DA**, Antiphospholipid antibodies, *Arch Pathol Lab Med* 126:1424, 2002.
  242. **Silver RM, Porter TF, van Leeuwen I, Jeng G, Scott JR, Branch DW**, Anticardiolipin antibodies: clinical consequences of "low titers", *Obstet Gynecol* 87:494, 1996.
  243. **Solano C, Lamuño M, Vargas A, Amezcua-Guerra LM**, Comparison of the 1999 Sapporo and 2006 revised criteria for the classification of the antiphospholipid syndrome, *Clin Exp Rheumatol* 27:914, 2009.
  244. **Miyakis S, Lockshin MD, Atsumi T, Branch DW, Brey RL, Cervera R, Derksen RH, De Groot PG, Koike T, Meroni PL, Rebar G, Schoenfeld Y, Tincani A, Vlachoyiannopoulos PG, Krilis SA**, International consensus statement on an update of the classification criteria for definite antiphospholipid syndrome (APS), *J Thromb Haemost* 4:295, 2006.
  245. **Hill JA**, Sporadic and recurrent spontaneous abortion, *Curr Probl Obstet Gynecol Fertil* 17:114, 1994.
  246. **Branch DW, Silver R, Pierangeli S, van Leeuwen I, Harris EN**, Antiphospholipid antibodies other than lupus anticoagulant and anticardiolipin antibodies in women with recurrent pregnancy loss, fertile controls, and antiphospholipid syndrome, *Obstet Gynecol* 89:549, 1997.
  247. **Lockwood CJ, Romero R, Feinberg RF, Clyne LP, Coster B, Hobbins JC**, The prevalence and biologic

significance of lupus anticoagulant and anticardiolipin antibodies in a general obstetric population, *Am J Obstet Gynecol* 161:369, 1989.

248. **Pattison NS, Chamley LW, McKay EJ, Liggins GC, Butler WS**, Antiphospholipid antibodies in pregnancy: prevalence and clinical associations, *Br J Obstet Gynaecol* 100:909, 1993.
249. **Branch DW, Silver RM, Blackwell JL, Reading JC, Scott JR**, Outcome of treated pregnancies in women with antiphospholipid syndrome: an update of the Utah experience, *Obstet Gynecol* 80:614, 1992.
250. **Cowchock FS, Reece EA, Balaban D, Branch DW, Plouffe L**, Repeated fetal losses associated with antiphospholipid antibodies: a collaborative randomized trial comparing prednisone with low-dose heparin treatment, *Am J Obstet Gynecol* 166:1318, 1992.
251. **Lima F, Khamashta MA, Buchanan NM, Kerslake S, Hunt BJ, Hughes GR**, A study of sixty pregnancies in patients with the antiphospholipid syndrome, *Clin Exp Rheumatol* 14:131, 1996.
252. **Out HJ, Bruinse HW, Christiaens GC, van Vliet M, de Groot PG, Nieuwenhuis HK, Derksen RH**, A prospective, controlled multicenter study on the obstetric risks of pregnant women with antiphospholipid antibodies, *Am J Obstet Gynecol* 167:26, 1992.
253. **Branch DW, Dudley DJ, Mitchell MD, Creighton KA, Abbott TM, Hammond EH, Daynes RA**, Immunoglobulin G fractions from patients with antiphospholipid antibodies cause fetal death in BALB/c mice: a model for autoimmune fetal loss, *Am J Obstet Gynecol* 163:210, 1990.
254. **Blank M, Cohen J, Toder V, Shoenfeld Y**, Induction of anti-phospholipid syndrome in naive mice with mouse lupus monoclonal and human polyclonal anti-cardiolipin antibodies, *Proc Natl Acad Sci U S A* 88:3069, 1991.
255. **Chamley LW, Pattison NS, McKay EJ**, The effect of human anticardiolipin antibodies on murine pregnancy, *J Reprod Immunol* 27:123, 1994.
256. **Branch DW**, Immunologic disease and fetal death, *Clin Obstet Gynecol* 30:295, 1987.
257. **Oshiro BT, Silver RM, Scott JR, Yu H, Branch DW**, Antiphospholipid antibodies and fetal death, *Obstet Gynecol* 87:489, 1996.
258. **Harris EN, Asherson RA, Gharavi AE, Morgan SH, Derue G, Hughes GR**, Thrombocytopenia in SLE and related autoimmune disorders: association with anticardiolipin antibody, *Br J Haematol* 59:227, 1985.
259. **Tulppala M, Viinikka L, Ylikorkala O**, Thromboxane dominance and prostacyclin deficiency in habitual abortion, *Lancet* 337:879, 1991.
260. **Rand JH, Wu XX, Andree HA, Lockwood CJ, Guller S, Scher J, Harpel PC**, Pregnancy loss in the antiphospholipid-antibody syndrome—a possible thrombogenic mechanism, *N Engl J Med* 337:154, 1997.
261. **Rand JH**, Antiphospholipid antibody-mediated disruption of the annexin-V antithrombotic shield: a thrombogenic mechanism for the antiphospholipid syndrome, *J Autoimmun* 15:107, 2000.
262. **Erlendsson K, Steinsson K, Johannsson JH, Geirsson RT**, Relation of antiphospholipid antibody and placental bed inflammatory vascular changes to the outcome of pregnancy in successive pregnancies of 2 women with systemic lupus erythematosus, *J Rheumatol* 20:1779, 1993.
263. **Di Simone N, Di Nicuolo F, D'Ippolito S, Castellani R, Tersigni C, Caruso A, Meroni P, Marana R**, Antiphospholipid antibodies affect human endometrial angiogenesis, *Biol Reprod* 83(2):212, 2010.
264. **Regan L, Rai R**, Thrombophilia and pregnancy loss, *J Reprod Immunol* 55:163, 2002.
265. **Pijnenborg R, Bland JM, Robertson WB, Brosens I**, Uteroplacental arterial changes related to interstitial trophoblast migration in early human pregnancy, *Placenta* 4:397, 1983.
266. **Abrahams VM**, Mechanisms of antiphospholipid antibody-associated pregnancy complications, *Thromb Res* 124:521, 2009.
267. **Kwak-Kim J, Agcaoili MS, Aleta L, Liao A, Ota K, Dambaeva S, Beaman K, Kim JW, Gilman-Sachs A**, Management of women with recurrent pregnancy losses and antiphospholipid antibody syndrome, *Am J Reprod Immunol* 69(6):596, 2013. doi:10.1111/aji.12114.
268. **Kutteh WH**, Antiphospholipid antibody-associated recurrent pregnancy loss: treatment with heparin and low-dose aspirin is superior to low-dose aspirin alone, *Am J Obstet Gynecol* 174:1584, 1996.
269. **Rai R, Cohen H, Dave M, Regan L**, Randomised controlled trial of aspirin and aspirin plus heparin in pregnant women with recurrent miscarriage associated with phospholipid antibodies (or antiphospholipid

antibodies), *Br Med J* 314:253, 1997.

270. **Tulppala M, Marttunen M, Söderström-Anttila V, Foudila T, Ailus K, Palosuo T, Ylikorkala O**, Low-dose aspirin in prevention of miscarriage in women with unexplained or autoimmune related recurrent miscarriage: effect on prostacyclin and thromboxane A2 production, *Hum Reprod* 12:1567, 1997.
271. **Farquharson RG, Quenby S, Greaves M**, Antiphospholipid syndrome in pregnancy: a randomized, controlled trial of treatment, *Obstet Gynecol* 100:408, 2002.
272. **Laskin CA, Spitzer KA, Clark CA, Crowther MR, Ginsberg JSH, G A, Kingdom GA, Kingdom JC, Barrett J, Gent M**, Low molecular weight heparin and aspirin for recurrent pregnancy loss: results from the randomized, controlled HepASA trial, *J Rheumatol* 36:279, 2009.
273. **Backos M, Rai R, Baxter N, Chilcott IT, Cohen H, Regan L**, Pregnancy complications in women with recurrent miscarriage associated with antiphospholipid antibodies treated with low dose aspirin and heparin, *Br J Obstet Gynaecol* 106:102, 1999.
274. **Empson M, Lassere M, Craig J, Scott J**, Prevention of recurrent miscarriage for women with antiphospholipid antibody or lupus anticoagulant, *Cochrane Database Syst Rev* (2):CD002859, 2005.
275. **Ziakas PD, Pavlou M, Voulgarelis M**, Heparin treatment in antiphospholipid syndrome with recurrent pregnancy loss: a systematic review and meta-analysis, *Obstet Gynecol* 115:1256, 2010.
276. **Clark P, Walker ID, Langhorne P, Crichton L, Thomson A, Greaves M, Whyte S, Greer IA, Scottish Pregnancy Intervention Study (SPIN) collaborators**, SPIN (Scottish Pregnancy Intervention) study: a multicenter, randomized controlled trial of low-molecular-weight heparin and low-dose aspirin in women with recurrent miscarriage, *Blood* 115:4162, 2010.
277. **Kaandorp SP, Goddijn M, van der Post JA, Hutten BA, Verhoeve HR, Hamulyá K, Mol BW, Folkeringa N, Nahuis M, Papatsonis DN, Büller HR, Van der Veen F, Middeldorp S**, Aspirin plus heparin or aspirin alone in women with recurrent miscarriage, *N Engl J Med* 362:1586, 2010.
278. **Laurent P, Dussarat GV, Bonal J, Jegou C, Talard P, Bouchiat C, Cellarier G**, Low molecular weight heparins: a guide to their optimum use in pregnancy, *Drugs* 62:463, 2002.
279. **Bar J, Cohen-Sacher B, Hod M, Blickstein D, Lahav J, Merlob P**, Low-molecular-weight heparin for thrombophilia in pregnant women, *Int J Gynaecol Obstet* 69:209, 2000.
280. **Younis JS, Ohel G, Brenner B, Haddad S, Lanir N, Ben-Ami M**, The effect of thromboprophylaxis on pregnancy outcome in patients with recurrent pregnancy loss associated with factor V Leiden mutation, *Br J Obstet Gynaecol* 107:415, 2000.
281. **Brenner B, Hoffman R, Blumenfeld Z, Weiner Z, Younis JS**, Gestational outcome in thrombophilic women with recurrent pregnancy loss treated by enoxaparin, *Thromb Haemost* 83:693, 2000.
282. **Noble LS, Kutteh WH, Lashey N, Franklin RD, Herrada J**, Antiphospholipid antibodies associated with recurrent pregnancy loss: prospective, multicenter, controlled pilot study comparing treatment with low-molecular-weight heparin versus unfractionated heparin, *Fertil Steril* 83:684, 2005.
283. **Stephenson MD, Ballem PJ, Tsang P, Purkiss S, Ensworth S, Houlihan E, Ensom MH**, Treatment of antiphospholipid antibody syndrome (APS) in pregnancy: a randomized pilot trial comparing low molecular weight heparin to unfractionated heparin, *J Obstet Gynaecol Can* 26:729, 2004.
284. **Laskin CA, Bombardier C, Hannah ME, Mandel FP, Ritchie JW, Farewell V, Farine D, Spitzer K, Fielding L, Soloninka CA, Yeung M**, Prednisone and aspirin in women with autoantibodies and unexplained recurrent fetal loss, *N Engl J Med* 337:148, 1997.
285. **Fawzy M, Shokeir T, El-Tatongy M, Warda O, El-Refaiey AA, Mosbah A**, Treatment options and pregnancy outcome in women with idiopathic recurrent miscarriage: a randomized placebo-controlled study, *Arch Gynecol Obstet* 278:33, 2008.
286. **Hutton B, Sharma R, Fergusson D, Tinmouth A, Hebert P, Jamieson J, Walker M**, Use of intravenous immunoglobulin for treatment of recurrent miscarriage: a systematic review, *BJOG* 114(2):134, 2007.
287. **Vaquero E, Lazzarin N, Valensise H, Menghini S, Di Pierro G, Cesa F, Romanini C**, Pregnancy outcome in recurrent spontaneous abortion associated with antiphospholipid antibodies: a comparative study of intravenous immunoglobulin versus prednisone plus low-dose aspirin, *Am J Reprod Immunol* 45:174, 2001.
288. **Harris EN, Pierangeli SS**, Utilization of intravenous immunoglobulin therapy to treat recurrent pregnancy loss

in the antiphospholipid syndrome: a review, *Scand J Rheumatol Suppl* 107:97, 1998.

289. **Esplin MS, Branch DW, Silver R, Stagnaro-Green A**, Thyroid autoantibodies are not associated with recurrent pregnancy loss, *Am J Obstet Gynecol* 179:1583, 1998.
290. **Rushworth FH, Backos M, Rai R, Chilcott IT, Baxter N, Regan L**, Prospective pregnancy outcome in untreated recurrent miscarriers with thyroid autoantibodies, *Hum Reprod* 15:1637, 2000.
291. **Negro R, Mangieri T, Coppola L, Presicce G, Casavola EC, Gismondi R, Locorotondo G, Caroli P, Pezzarossa A, Dazzi D, Hassan H**, Levothyroxine treatment in thyroid peroxidase antibody-positive women undergoing assisted reproduction technologies: a prospective study, *Hum Reprod* 20:1529, 2005.
292. **Glinoeer D, Riahi M, Grun JP, Kinthaert J**, Risk of subclinical hypothyroidism in pregnant women with asymptomatic autoimmune thyroid disorders, *J Clin Endocrinol Metab* 79:197, 1994.
293. **Bustos D, Moret A, Tembutti M, Gorgorza S, Testa R, Ascione A, Prigoshin N**, Autoantibodies in Argentine women with recurrent pregnancy loss, *Am J Reprod Immunol* 55:201, 2006.
294. **Hanafusa N, Noiri E, Yamashita T, Kondo Y, Suzuki M, Watanabe Y, Kanai T, Miyashita E, Tsuno NH, Fujii T, Kozuma S, Takahashi K, Taketani Y, Nakao A, Fujita T**, Successful treatment by double filtrate plasmapheresis in a pregnant woman with the rare P blood group and a history of multiple early miscarriages, *Ther Apher Dial* 10:498, 2006.
295. **McIntyre JA, Faulk WP, Nichols-Johnson VR, Taylor CG**, Immunologic testing and immunotherapy in recurrent spontaneous abortion, *Obstet Gynecol* 67:169, 1986.
296. **Berke J, Johansen K**, The formation of HLA antibodies in pregnancy: the antigenicity of aborted and term fetuses, *J Obstet Gynecol Br Commonw* 81:222, 1974.
297. **Coulam CB**, Immunologic tests in the evaluation of reproductive disorders: a critical review, *Am J Obstet Gynecol* 167:1844, 1992.
298. **Cowchock FS, Smith JB**, Predictors for live birth after unexplained spontaneous abortions: correlations between immunologic test results, obstetric histories, and outcome of next pregnancy without treatment, *Am J Obstet Gynecol* 167:1208, 1992.
299. **Beer AE, Quebbeman JF, Ayers JW, Haines RF**, Major histocompatibility complex antigens, maternal and paternal immune responses, and chronic habitual abortions in humans, *Am J Obstet Gynecol* 141:987, 1981.
300. **Rocklin RE, Kitzmiller JL, Garvoy MR**, Maternal-fetal relation. II. Further characterization of an immunologic blocking factor that develops during pregnancy, *Clin Immunol Immunopathol* 22:305, 1982.
301. **Sargent IL, Wilkins T, Redman CW**, Maternal immune responses to the fetus in early pregnancy and recurrent miscarriage, *Lancet* 2:1099, 1988.
302. **Porter TF, Scott JR**, Alloimmune causes of recurrent pregnancy loss, *Semin Reprod Med* 18:393, 2000.
303. **Ober C, Hyslop T, Elias S, Weitkamp LR, Hauck WW**, Human leukocyte antigen matching and fetal loss: results of a 10 year prospective study, *Hum Reprod* 13:33, 1998.
304. **Sbracia M, Mastrone M, Scarpellini F, Grasso JA**, Influence of histocompatibility antigens in recurrent spontaneous abortion couples and on their reproductive performances, *Am J Reprod Immunol* 35:85, 1996.
305. **Weitkamp LR, Ober C**, Ancestral and recombinant 16-locus HLA haplotypes in the Hutterites, *Immunogenetics* 49:491, 1999.
306. **Berger DS, Hogge WA, Barmada MM, Farrell RE**, Comprehensive analysis of HLA-G: implications for recurrent spontaneous abortions, *Reprod Sci* 17:331, 2010.
307. **Kolte AM, Steffensen R, Nielsen HS, Hvid TV, Christiansen OB**, Study of the structure and impact of human leukocyte antigen (HLA)-G-A, HLA-G-B, and HLA-G-DRB1 haplotypes in families with recurrent miscarriage, *Hum Immunol* 71:482, 2010.
308. **Clark DA, Vince G, Flanders KC, Hirte H, Starkey P**, CD56+ lymphoid cells in human first trimester pregnancy decidua as a source of novel transforming growth factor-beta 2-related immunosuppressive factors, *Hum Reprod* 9:2270, 1994.
309. **Kodama T, Hara T, Okamoto E, Kusunoki Y, Ohama K**, Characteristic changes of large granular lymphocytes that strongly express CD56 in endometrium during the menstrual cycle and early pregnancy, *Hum Reprod* 13:1036, 1998.
310. **Gendron RL, Baines MG**, Infiltrating decidual natural killer cells are associated with spontaneous abortion in

mice, *Cell Immunol* 113:261, 1988.

311. **de Fougerolles AR, Baines MG**, Modulation of the natural killer cell activity in pregnant mice alters the spontaneous abortion rate, *J Reprod Immunol* 11:147, 1987.
312. **Guimond MJ, Wang B, Croy BA**, Engraftment of bone marrow from severe combined immunodeficient (SCID) mice reverses the reproductive deficits in natural killer cell-deficient tg epsilon 26 mice, *J Exp Med* 187:217, 1998. <https://doi.org/10.1084/jem.187.2.217>
313. **Burke SD, Barrette VF, Bianco J, Thorne JG, Yamada AT, Pang SC, Adams MA, Croy BA**, Spiral arterial remodeling is not essential for normal blood pressure regulation in pregnant mice, *Hypertension* 55:729, 2010.
314. **Lima PD, Zhang J, Dunk C, Lye SJ, Croy BA**, Leukocyte driven-decidual angiogenesis in early pregnancy, *Cell Mol Immunol* 11(6):522, 2014.
315. **Starkey PM, Sargent IL, Redman CW**, Cell populations in human early pregnancy decidua: characterization and isolation of large granular lymphocytes by flow cytometry, *Immunology* 65:129, 1988.
316. **Lachapelle MH, Miron P, Hemmings R, Roy DC**, Endometrial T, B, and NK cells in patients with recurrent spontaneous abortion. Altered profile and pregnancy outcome, *J Immunol* 156:4027, 1996.
317. **Coulam CB, Goodman C, Roussev RG, Thomason EJ, Beaman KD**, Systemic CD56+ cells can predict pregnancy outcome, *Am J Reprod Immunol* 33:40, 1995.
318. **Beer AE, Kwak JY, Ruiz JE**, Immunophenotypic profiles of peripheral blood lymphocytes in women with recurrent pregnancy losses and in infertile women with multiple failed in vitro fertilization cycles, *Am J Reprod Immunol* 35:376, 1996.
319. **Yamamoto T, Takahashi Y, Kase N, Mori H**, Role of decidual natural killer (NK) cells in patients with missed abortion: differences between cases with normal and abnormal chromosome, *Clin Exp Immunol* 116:449, 1999.
320. **Gilman-Sachs A, DuChateau BK, Aslakson CJ, Wohlgemuth GP, Kwak JY, Beer AE, Beaman KD**, Natural killer (NK) cell subsets and NK cell cytotoxicity in women with histories of recurrent spontaneous abortions, *Am J Reprod Immunol* 41:99, 1999.
321. **Palmer EM, van Seventer GA**, Human T helper cell differentiation is regulated by the combined action of cytokines and accessory cell-dependent costimulatory signals, *J Immunol* 158:2654, 1997.
322. **Asnagli H, Murphy KM**, Stability and commitment in T helper cell development, *Curr Opin Immunol* 13:242, 2001.
323. **O'Garra A, Arai N**, The molecular basis of T helper 1 and T helper 2 cell differentiation, *Trends Cell Biol* 10:542, 2000.
324. **Romagnani S**, Human TH1 and TH2 subsets: doubt no more, *Immunol Today* 12:256, 1991.
325. **Zammiti W, Mtiraoui N, Finan RR, Almawi WY, Mahjoub T**, Tumor necrosis factor alpha and lymphotoxin alpha haplotypes in idiopathic recurrent pregnancy loss, *Fertil Steril* 91:1903, 2009.
326. **Finan RR, Al-Irhayim Z, Mustafa FE, Al-Zaman I, Mohammed FA, Al-Khateeb GM, Madan S, Issa AA, Almawi WY**, Tumor necrosis factor-alpha polymorphisms in women with idiopathic recurrent miscarriage, *J Reprod Immunol* 84:186, 2010.
327. **Hill JA, Polgar K, Anderson DJ**, T-helper 1-type immunity to trophoblast in women with recurrent spontaneous abortion, *JAMA* 273:1933, 1995.
328. **Hill JA, Polgar K, Harlow BL, Anderson DJ**, Evidence of embryo- and trophoblast-toxic cellular immune response(s) in women with recurrent spontaneous abortion, *Am J Obstet Gynecol* 166:1044, 1992.
329. **Yamada H, Polgar K, Hill JA**, Cell-mediated immunity to trophoblast antigens in women with recurrent spontaneous abortion, *Am J Obstet Gynecol* 170:1339, 1994.
330. **Yang H, Qiu L, Chen GP, Ye Z, Lü C, Lin Q**, Proportional change of CD4+ CD25+ regulatory T cells in decidua and peripheral blood in unexplained recurrent spontaneous abortion patients, *Fertil Steril* 89:656, 2008.
331. **Wang WJ, Hao CF, Wang WJ, Lin Y, Yin GJ, Bao SH, Qiu LH, Lin QD**, Increased prevalence of T helper 17 (Th17) cells in peripheral blood and decidua in unexplained recurrent spontaneous abortion patients, *J Reprod Immunol* 84:164, 2010.
332. **Hill JA**, T-helper 1-type immunity to trophoblast: evidence for a new immunological mechanism for recurrent

abortion in women, *Hum Reprod* 10(Suppl 2):114, 1995.

333. **Ecker JL, Laufer MR, Hill JA**, Measurement of embryotoxic factors is predictive of pregnancy outcome in women with a history of recurrent abortions, *Obstet Gynecol* 81:84, 1993.
334. **Jenkins C, Roberts J, Wilson R, MacLean MA, Shilito J, Walker JJ**, Evidence of a T(H) 1 type response associated with recurrent miscarriage, *Fertil Steril* 73:1206, 2000.
335. **Yang KM, Ntrivalas E, Cho HJ, Kim NY, Beaman K, Gilman-Sachs A, Kwak-Kim J**, Women with multiple implantation failures and recurrent pregnancy losses have increased peripheral blood T cell activation, *Am J Reprod Immunol* 63:370, 2010.
336. **Mei S, Tan JY, Chen HW, Chen Y, Zhang J**, Changes of CD4(+)CD25(high) regulatory T cells and FOXP3 expression in unexplained recurrent spontaneous abortion patients, *Fertil Steril* 94(6):2244, 2010.
337. **Toth B, Haufe T, Scholz C, Kuhn C, Friese K, Karamouti M, Makrigiannakis A, Jeschke U**, Placental interleukin-15 expression in recurrent miscarriage, *Am J Reprod Immunol* 64:402, 2010.
338. **Bombell S, McGuire W**, Cytokine polymorphisms in women with recurrent pregnancy loss: meta-analysis, *Aust N Z J Obstet Gynaecol* 48:147, 2008.
339. **Choi YK, Kwak-Kim J**, Cytokine gene polymorphisms in recurrent spontaneous abortions: a comprehensive review, *Am J Reprod Immunol* 60:91, 2008.
340. **Levrant S, Coulam CB, Jeyendran RS**, Interleukin 1 receptor antagonist gene polymorphisms are not risk factors for recurrent pregnancy loss: evaluation of couples, *Am J Reprod Immunol* 60:224, 2008.
341. **Dai MZ, Pan YQ, Chen XJ, Qian RJ, Chen DH, Cui TW, Lin A, Yan WH**, IL-1 receptor antagonist gene polymorphism in idiopathic recurrent spontaneous abortion in a Chinese Han population, *Int J Immunogenet* 35(5):393, 2010.
342. **Kwak JY, Gilman-Sachs A, Moretti M, Beaman KD, Beer AE**, Natural killer cell cytotoxicity and paternal lymphocyte immunization in women with recurrent spontaneous abortions, *Am J Reprod Immunol* 40:352, 1998.
343. **Ober C, Karrison T, Odem RR, Barnes RB, Branch DW, Stephenson MD, Baron B, Walker MA, Scott JR, Schreiber JR**, Mononuclear-cell immunisation in prevention of recurrent miscarriages: a randomised trial, *Lancet* 354:365, 1999.
344. **Scott JR**, Immunotherapy for recurrent miscarriage, *Cochrane Database Syst Rev* (1):CD000112, 2003.
345. **Dwyer JM**, Intravenous therapy with gamma globulin, *Adv Intern Med* 32:111, 1987.
346. **Thornton CA, Ballow M**, Safety of intravenous immunoglobulin, *Arch Neurol* 50:135, 1993.
347. **Recurrent Miscarriage Immunotherapy Trialists Group**, Worldwide collaborative observational study and meta-analysis on allogenic leukocyte immunotherapy for recurrent spontaneous abortion, *Am J Reprod Immunol* 32:55, 1994.
348. **Porter TF, LaCoursiere Y, Scott JR**, Immunotherapy for recurrent miscarriage, *Cochrane Database Syst Rev* 19:CD000112, 2006.
349. **Scarpellini F, Sbracia M**, Use of granulocyte colony-stimulating factor for the treatment of unexplained recurrent miscarriage: a randomised controlled trial, *Hum Reprod* 24:2702, 2009.
350. **Zafardoust S, Akhondi MM, Sadeghi MR, Mohammadzadeh A, Karimi A, Jouhari S, Ansaripour S**, Efficacy of intrauterine injection of granulocyte colony stimulating factor (G-CSF) on treatment of unexplained recurrent miscarriage: a pilot RCT study, *J Reprod Infertil* 18(4):379, 2017.
351. **Dahlback B**, Inherited thrombophilia: resistance to activated protein C as a pathogenic factor of venous thromboembolism, *Blood* 85:607, 1995.
352. **Svensson PJ, Dahlbäck B**, Resistance to activated protein C as a basis for venous thrombosis, *N Engl J Med* 330:517, 1994.
353. **Poort SR, Rosendaal FR, Reitsma PH, Bertina RM**, A common genetic variation in the 3'-untranslated region of the prothrombin gene is associated with elevated plasma prothrombin levels and an increase in venous thrombosis, *Blood* 88:3698, 1996.
354. **Frosst P, Blom HJ, Milos R, Goyette P, Sheppard CA, Matthews RG, Boers GJ, den Heijer M, Kluijtmans LA, van den Heuvel LP, et al.**, A candidate genetic risk factor for vascular disease: a common mutation in methylenetetrahydrofolate reductase, *Nat Genet* 10:111, 1995.

355. **Pauer HU, Burfeind P, Kostering H, Emons G, Hinney B**, Factor XII deficiency is strongly associated with primary recurrent abortions, *Fertil Steril* 80:590, 2003.
356. **Bertina RM, Koeleman BP, Koster T, Rosendaal FR, Dirven RJ, de Ronde H, van den Velden PA, Reitsma PH**, Mutation in blood coagulation factor V associated with resistance to activated protein C, *Nature* 369:64, 1994.
357. **Rey E, Kahn SR, David M, Shrier I**, Thrombophilic disorders and fetal loss: a meta-analysis, *Lancet* 361:901, 2003.
358. **Rai R, Backos M, Elgaddal S, Shlebak A, Regan L**, Factor V Leiden and recurrent miscarriage—prospective outcome of untreated pregnancies, *Hum Reprod* 17:442, 2002.
359. **Yenicesu GI, Cetin M, Ozdemir O, Cetin A, Ozen F, Yenicesu C, Yildiz C, Kocak N**, A prospective case-control study analyzes 12 thrombophilic gene mutations in Turkish couples with recurrent pregnancy loss, *Am J Reprod Immunol* 63:126, 2010.
360. **Gris JC, Ripart-Neveu S, Maugard C, Tailland ML, Brun S, Courtieu C, Biron C, Hoffet M, Hedon B, Mares P**, Retrospective evaluation of the prevalence of haemostasis abnormalities in unexplained primary early recurrent miscarriages. The Nimes Obstetricians and Haematologists (NOHA) Study. *Thromb Haemost* 77:1096, 1997.
361. **Rai R, Backos M, Baxter N, Chilcott I, Regan L**, Recurrent miscarriage—an aspirin a day? *Hum Reprod* 15:2220, 2000.
362. **Brenner B, Sarig G, Weiner Z, Younis J, Blumenfeld Z, Lanir N**, Thrombophilic polymorphisms are common in women with fetal loss without apparent cause, *Thromb Haemost* 82:6, 1999.
363. **Brenner B, Mandel H, Lanir N, Younis J, Rothbart H, Ohel G, Blumenfeld Z**, Activated protein C resistance can be associated with recurrent fetal loss, *Br J Haematol* 97:551, 1997.
364. **Kutteh WH, Park VM, Deitcher SR**, Hypercoagulable state mutation analysis in white patients with early first-trimester recurrent pregnancy loss, *Fertil Steril* 71:1048, 1999.
365. **Souza SS, Ferriani RA, Pontes AG, Zago MA, Franco RF**, Factor V Leiden and factor II G20210A mutations in patients with recurrent abortion, *Hum Reprod* 14:2448, 1999.
366. **Holmes ZR, Regan L, Chilcott I, Cohen H**, The C677T MTHFR gene mutation is not predictive of risk for recurrent fetal loss, *Br J Haematol* 105:98, 1999.
367. **Rai R, Shlebak A, Cohen H, Backos M, Holmes Z, Marriott K, Regan L**, Factor V Leiden and acquired activated protein C resistance among 1000 women with recurrent miscarriage, *Hum Reprod* 16:961, 2001.
368. **Preston FE, Rosendaal FR, Walker ID, Briet E, Berntorp E, Conard J, Fontcuberta J, Makris M, Mariani G, Noteboom W, Pabinger I, Legnani C, Scharrer I, Schulman S, van der Meer FJ**, Increased fetal loss in women with heritable thrombophilia, *Lancet* 348:913, 1996.
369. **Kupferminc MJ, Eldor A, Steinman N, Many A, Bar-Am A, Jaffa A, Fait G, Lessing JB**, Increased frequency of genetic thrombophilia in women with complications of pregnancy, *N Engl J Med* 340:9, 1999.
370. **Younis JS, Brenner B, Ohel G, Tal J, Lanir N, Ben-Ami M**, Activated protein C resistance and factor V Leiden mutation can be associated with first- as well as second-trimester recurrent pregnancy loss, *Am J Reprod Immunol* 43:31, 2000.
371. **Rai R, Regan L**, Thrombophilia and adverse pregnancy outcome, *Semin Reprod Med* 18:369, 2000.
372. **Dizon-Townson DS, Meline L, Nelson LM, Varner M, Ward K**, Fetal carriers of the factor V Leiden mutation are prone to miscarriage and placental infarction, *Am J Obstet Gynecol* 177:402, 1997.
373. **Rees DC, Cox M, Clegg JB**, World distribution of factor V Leiden, *Lancet* 346:1133, 1995.
374. **Carp H, Dolitzky M, Inbal A**, Thromboprophylaxis improves the live birth rate in women with consecutive recurrent miscarriages and hereditary thrombophilia, *J Thromb Haemost* 1:433, 2003.
375. **Monien S, Ladecki O, Baumgarten S, Salama A, Dörner T, Kiese-wetter H**, Use of heparin in women with early and late miscarriages with and without thrombophilia, *Clin Appl Thromb Hemost* 15:636, 2009.
376. **Abalovich M, Gutierrez S, Alcaraz G, Maccallini G, Garcia A, Levalle O**, Overt and subclinical hypothyroidism complicating pregnancy, *Thyroid* 12:63, 2002.
377. **Montoro M, Collea JV, Frasier D, Mestman J**, Successful outcome of pregnancy in women with hypothyroidism, *Ann Intern Med* 94:31, 1981.

378. **Roti E, Minelli R, Salvi M**, Clinical review 80: management of hyperthyroidism and hypothyroidism in the pregnant woman, *J Clin Endocrinol Metab* 81:1679, 1996.
379. **Wang S, Teng WP, Li JX, Wang WW, Shan ZY**, Effects of maternal subclinical hypothyroidism on obstetrical outcomes during early pregnancy, *J Endocrinol Invest* 35(3):322, 2012.
380. **Ashoor G, Maiz N, Rotas M, Jawdat F, Nicolaides KH**, Maternal thyroid function at 11 to 13 weeks of gestation and subsequent fetal death, *Thyroid* 20(9):989, 2010. doi:10.1089/thy.2010.0058.
381. **De Vivo A, Mancuso A, Giacobbe A, Moleti M, Maggio Savasta L, De Dominicis R, Priolo AM, Vermiglio F**, Thyroid function in women found to have early pregnancy loss, *Thyroid* 20(6):633, 2010. doi:10.1089/thy.2009.0323.
382. **Cleary-Goldman J, Malone FD, Lambert-Messerlian G, Sullivan L, Canick J, Porter TF, Luthy D, Gross S, Bianchi DW, D'Alton ME**, Maternal thyroid hypofunction and pregnancy outcome, *Obstet Gynecol* 112(1):85, 2008. doi:10.1097/AOG.0b013e3181788dd7.
383. **Michalakakis KG, Mesen TB, Brayboy LM, Yu B, Richter KS, Levy M, Widra E, Segars JH**, Subclinical elevations of thyroid-stimulating hormone and assisted reproductive technology outcomes, *Fertil Steril* 95(8):2634, 2011.
384. **Mandel SJ, Larsen PR, Seely EW, Brent GA**, Increased need for thyroxine during pregnancy in women with primary hypothyroidism, *N Engl J Med* 323:91, 1990.
385. **Kaplan MM**, Monitoring thyroxine treatment during pregnancy, *Thyroid* 2:147, 1992.
386. **Alexander EK, Marqusee E, Lawrence J, Jarolim P, Fischer GA, Larsen PR**, Timing and magnitude of increases in levothyroxine requirements during pregnancy in women with hypothyroidism, *N Engl J Med* 351:241, 2004.
387. **Mandel SJ, Spencer CA, Hollowell JG**, Are detection and treatment of thyroid insufficiency in pregnancy feasible? *Thyroid* 15:44, 2005.
388. **Mills JE, Simpson JL, Driscoll SG**, Incidence of spontaneous abortion among normal women and insulin-dependent diabetic women whose pregnancies were identified within 21 days of conception, *N Engl J Med* 319:1617, 1988.
389. **Miodovnik M, Mimouni F, Siddiqi TA, Khoury J, Berk MA**, Spontaneous abortions in repeat diabetic pregnancies: a relationship with glycemic control, *Obstet Gynecol* 75:75, 1990.
390. **Greene MF**, Spontaneous abortions and major malformations in women with diabetes mellitus, *Semin Reprod Endocrinol* 17:127, 1999.
391. **Sutherland HW, Pritchard CW**, Increased incidence of spontaneous abortion in pregnancies complicated by maternal diabetes mellitus, *Am J Obstet Gynecol* 155:135, 1986.
392. **Regan L, Owen EJ, Jacobs HS**, Hypersecretion of luteinising hormone, infertility, and miscarriage, *Lancet* 336:1141, 1990.
393. **Tulppala M, Stenman U-H, Cacciato B, Ylikorkala O**, Polycystic ovaries and levels of gonadotrophins and androgens in recurrent miscarriage: prospective study in 50 women, *Br J Obstet Gynaecol* 100:348, 1993.
394. **Sagle M, Bishop K, Ridley N, Alexander FM, Michel M, Bonney RC, Beard RW, Franks S**, Recurrent early miscarriage and polycystic ovaries, *Br Med J* 297:1027, 1988.
395. **Homburg R, Armar NA, Eshel A, Adams J, Jacobs HS**, Influence of serum luteinising hormone concentrations on ovulation, conception, and early pregnancy loss in polycystic ovary syndrome, *Br Med J* 297:1024, 1988.
396. **Clifford K, Rai R, Watson H, Franks S, Regan L**, Does suppressing luteinising hormone secretion reduce the miscarriage rate? Results of a randomised controlled trial, *Br Med J* 312:1508, 1996.
397. **Watson H, Kiddy DS, Hamilton-Fairley D, Scanlon MJ, Barnard C, Collins WP, Bonney RC, Franks S**, Hypersecretion of luteinizing hormone and ovarian steroids in women with recurrent early miscarriage, *Hum Reprod* 8:829, 1993.
398. **Moggetti P, Castello R, Negri C, Tosi F, Perrone F, Caputo M, Zanolin E, Muggeo M**, Metformin effects on clinical features, endocrine and metabolic profiles, and insulin sensitivity in polycystic ovary syndrome: a randomized, double-blind, placebo-controlled 6-month trial, followed by open, long-term clinical evaluation, *J Clin Endocrinol Metab* 85:139, 2000.



399. **Nestler JE, Jakubowicz DJ, Evans WS, Pasquali R**, Effects of metformin on spontaneous and clomiphene-induced ovulation in the polycystic ovary syndrome, *N Engl J Med* 338:1876, 1998.
400. **Velázquez E, Acosta A, Mendoza SG**, Menstrual cyclicality after metformin therapy in polycystic ovary syndrome, *Obstet Gynecol* 90:392, 1997.
401. **Glueck CJ, Wang P, Fontaine R, Tracy T, Sieve-Smith L**, Metformin-induced resumption of normal menses in 39 of 43 (91%) previously amenorrheic women with the polycystic ovary syndrome, *Metabolism* 48:511, 1999.
402. **Glueck CJ, Wang P, Fontaine RN, Sieve-Smith L, Tracy T, Moore SK**, Plasminogen activator inhibitor activity: an independent risk factor for the high miscarriage rate during pregnancy in women with polycystic ovary syndrome, *Metabolism* 48:1589, 1999.
403. **Velazquez EM, Mendoza SG, Wang P, Glueck CJ**, Metformin therapy is associated with a decrease in plasma plasminogen activator inhibitor-1, lipoprotein(a), and immunoreactive insulin levels in patients with the polycystic ovary syndrome, *Metabolism* 46:454, 1997.
404. **Atiomo WU, Bates SA, Condon JE, Shaw S, West JH, Prentice AG**, The plasminogen activator system in women with polycystic ovary syndrome, *Fertil Steril* 69:236, 1998.
405. **Sampson M, Kong C, Patel A, Unwin R, Jacobs HS**, Ambulatory blood pressure profiles and plasminogen activator inhibitor (PAI-1) activity in lean women with and without the polycystic ovary syndrome, *Clin Endocrinol (Oxf)* 45:623, 1996.
406. **Glueck CJ, Phillips H, Cameron D, Sieve-Smith L, Wang P**, Continuing metformin throughout pregnancy in women with polycystic ovary syndrome appears to safely reduce first-trimester spontaneous abortion: a pilot study, *Fertil Steril* 75:46, 2001.
407. **Glueck CJ, Wang P, Goldenberg N, Sieve-Smith L**, Pregnancy outcomes among women with polycystic ovary syndrome treated with metformin, *Hum Reprod* 17:2858, 2002.
408. **Jakubowicz DJ, Iuorno MJ, Jakubowicz S, Roberts KA, Nestler JE**, Effects of metformin on early pregnancy loss in the polycystic ovary syndrome, *J Clin Endocrinol Metab* 87:524, 2002.
409. **Nawaz FH, Rizvi J**, Continuation of metformin reduces early pregnancy loss in obese Pakistani women with polycystic ovary syndrome, *Gynecol Obstet Invest* 69:184, 2010.
410. **Moll E, Bossuyt PM, Korevaar JC, Lambalk CB, van der Veen F**, Effect of clomifene citrate plus metformin and clomifene citrate plus placebo on induction of ovulation in women with newly diagnosed polycystic ovary syndrome: randomised double blind clinical trial, *Br Med J* 332:1461, 2006.
411. **Legro RS, Barnhart HX, Schlaff WD, Carr BR, Diamond MP, Carson SA, Steinkampf MP, Coutifaris C, McGovern PG, Cataldo NA, Gosman GG, Nestler JE, Giudice LC, Leppert PC, Myers ER; for the Cooperative Multicenter Reproductive Medicine Network**, Clomiphene, metformin, or both for infertility in the polycystic ovary syndrome, *N Engl J Med* 356:551, 2007.
412. **Zain MM, Jamaluddin R, Ibrahim A, Norman RJ**, Comparison of clomiphene citrate, metformin, or the combination of both for first-line ovulation induction, achievement of pregnancy, and live birth in Asian women with polycystic ovary syndrome: a randomized controlled trial, *Fertil Steril* 91:514, 2009.
413. **Legro RS, Brzyski RG, Diamond MP, Coutifaris C, Schlaff WD, Casson P, Christman GM, Huang H, Yan Q, Alvero R, Haisenleder DJ, Barnhart KT, Bates GW, Usadi R, Lucidi S, Baker V, Trussell JC, Krawetz SA, Snyder P, Ohl D, Santoro N, Eisenberg E, Zhang H; NICHD Reproductive Medicine Network**, Letrozole versus clomiphene for infertility in the polycystic ovary syndrome, *N Engl J Med* 371(2):119, 2014. doi:10.1056/NEJMoa1313517.
414. **Homburg R**, Pregnancy complications in PCOS, *Best Pract Res Clin Endocrinol Metab* 20:281, 2006.
415. **Palomba S, Falbo A, Orio F Jr, Zullo F**, Effect of preconceptional metformin on abortion risk in polycystic ovary syndrome: a systematic review and meta-analysis of randomized controlled trials, *Fertil Steril* 92:1646, 2009.
416. **Glueck CJ, Wang P, Kobayashi S, Phillips H, Sieve-Smith L**, Metformin therapy throughout pregnancy reduces the development of gestational diabetes in women with polycystic ovary syndrome, *Fertil Steril* 77:520, 2002.
417. **Glueck CJ, Goldenberg N, Streicher P, Wang P**, Metformin and gestational diabetes, *Curr Diab Rep* 3:303,

2003.

418. **Glueck CJ, Goldenberg N, Wang P, Loftspring M, Sherman A**, Metformin during pregnancy reduces insulin, insulin resistance, insulin secretion, weight, testosterone and development of gestational diabetes: prospective longitudinal assessment of women with polycystic ovary syndrome from preconception throughout pregnancy, *Hum Reprod* 19:510, 2004.
419. **Coetzee EJ, Jackson WP**, The management of non-insulin-dependent diabetes during pregnancy, *Diabetes Res Clin Pract* 1:281, 1985.
420. **Coetzee EJ, Jackson WP**, Metformin in management of pregnant insulin-independent diabetes, *Diabetologia* 16:241, 1979.
421. **Hellmuth E, Damm P, Molsted-Pedersen L**, Oral hypoglycaemic agents in 118 diabetic pregnancies, *Diabet Med* 17:507, 2000.
422. **Hughes RC, Rowan JA**, Pregnancy in women with Type 2 diabetes: who takes metformin and what is the outcome? *Diabet Med* 23:318, 2006.
423. **Mathur R, Alexander CJ, Yano J, Trivax B, Azziz R**, Use of metformin in polycystic ovary syndrome, *Am J Obstet Gynecol* 199:596, 2008.
424. **Tulchinsky D, Hobel CJ**, Plasma human and chorionic gonadotropin, estrogen, estradiol, estriol, progesterone and  $17\alpha$ -hydroxyprogesterone in human pregnancy, *Am J Obstet Gynecol* 117:884, 1973.
425. **Scott R, Navot D, Liu HC, Rosenwaks Z**, A human in vivo model for the luteoplacental shift, *Fertil Steril* 56:481, 1991.
426. **Csapo AI, Pulkkinen M**, Indispensability of the human corpus luteum in the maintenance of early pregnancy. Luteectomy evidence, *Obstet Gynecol Surv* 33:69, 1978.
427. **Csapo AL, Pulkkinen MO, Wiest WG**, Effects of luteectomy and progesterone replacement in early pregnant patients, *Am J Obstet Gynecol* 115:759, 1973.
428. **Schneider MA, Davies MC, Honour JW**, The timing of placental competence in pregnancy after oocyte donation, *Fertil Steril* 59:1059, 1993.
429. **Azuma K, Calderon I, Besanko M, Maclachlan V, Healy D**, Is the luteo-placental shift a myth? Analysis of low progesterone levels in successful ART pregnancies, *J Clin Endocrinol Metab* 77:195, 1993.
430. **Sultan KM, Davis OK, Liu H-C, Rosenwaks Z**, Viable term pregnancy despite "subluteal" serum progesterone levels in the first trimester, *Fertil Steril* 60:363, 1993.
431. **Mishell Jr DR, Thorneycroft IH, Nagata Y, Murata T, Nakamura RM**, Serum gonadotropin and steroid patterns in early human gestation, *Am J Obstet Gynecol* 117:631, 1973.
432. **Filicori M, Butler JP, Crowley WF**, Neuroendocrine regulation of the corpus luteum in the human: evidence for pulsatile progesterone secretion, *J Clin Invest* 73:1638, 1984.
433. **Murray MJ, Meyer WR, Zaino RJ, Lessey BA, Novotny DB, Ireland I, Fritz MA**, A critical reanalysis of the accuracy, reproducibility, and clinical utility of histologic endometrial dating: a systematic study of the secretory phase in normally cycling, fertile women, *Fertil Steril* 81:1333, 2004.
434. **Jones GES, Delfs E**, Endocrine patterns in term pregnancies following abortion, *JAMA* 146:1212, 1951.
435. **Stouffer RL, Hodgen GD, Ottobre AC, Christian CD**, Follicular fluid treatment during the follicular versus luteal phase of the menstrual cycle: effects on corpus luteum function, *J Clin Endocrinol Metab* 58:1027, 1984.
436. **DiZerega GS, Hodgen GD**, Luteal phase dysfunction infertility: a sequel to aberrant folliculogenesis, *Fertil Steril* 35:489, 1981.
437. **Strott CA, Cargille CM, Ross GT, Lipsett MB**, The short luteal phase, *J Clin Endocrinol Metab* 30:246, 1970.
438. **Sherman BM, Korenman SG**, Measurement of plasma LH, FSH, estradiol and progesterone in disorders of the human menstrual cycle: the short luteal phase, *J Clin Endocrinol Metab* 38:89, 1974.
439. **Sheehan KL, Casper RF, Yen SS**, Luteal phase defects induced by an agonist of luteinizing hormone-releasing factor: a model for fertility control, *Science* 215:170, 1982.
440. **Quagliarello J, Weiss G**, Clomiphene citrate in the management of infertility associated with shortened luteal phases, *Fertil Steril* 31:373, 1979.
441. **Guzick DS, Zeleznik A**, Efficacy of clomiphene citrate in the treatment of luteal phase deficiency: quantity

versus quality of preovulatory follicles, *Fertil Steril* 54:206, 1990.

442. **Haas DM, Ramsey PS**, Progestogen for preventing miscarriage, *Cochrane Database Syst Rev* 16:CD003511, 2008.
443. **Witkin SS, Ledger WJ**, Antibodies to *Chlamydia trachomatis* in sera of women with recurrent spontaneous abortions, *Am J Obstet Gynecol* 167:135, 1992.
444. **Osser S, Persson K**, Chlamydial antibodies in women who suffer miscarriage, *Br J Obstet Gynaecol* 103:137, 1996.
445. **Quinn PA, Shewchuk AB, Shuber J, Lie KI, Ryan E, Sheu M, Chipman ML**, Serologic evidence of ureaplasma urealyticum infection in women with spontaneous pregnancy loss, *Am J Obstet Gynecol* 145:245, 1983.
446. **Donders GG, Van Bulck B, Caudron J, Londers L, Vereecken A, Spitz B**, Relationship of bacterial vaginosis and mycoplasmas to the risk of spontaneous abortion, *Am J Obstet Gynecol* 183:431, 2000.
447. **Ralph SG, Rutherford AJ, Wilson JD**, Influence of bacterial vaginosis on conception and miscarriage in the first trimester: cohort study, *Br Med J* 319:220, 1999.
448. **Oakeshott P, Hay P, Hay S, Steinke F, Rink E, Kerry S**, Association between bacterial vaginosis or chlamydial infection and miscarriage before 16 weeks' gestation: prospective community based cohort study, *Br Med J* 325:1334, 2002.
449. **Paavonen J, Kiviat N, Brunham RC, Stevens CE, Kuo CC, Stamm WE, Miettinen A, Soules M, Eschenbach DA, Holmes KK**, Prevalence and manifestations of endometritis among women with cervicitis, *Am J Obstet Gynecol* 152:280, 1985.
450. **Korn AP, Bolan G, Padian N, Ohm-Smith M, Schachter J, Landers DV**, Plasma cell endometritis in women with symptomatic bacterial vaginosis, *Obstet Gynecol* 85:387, 1995.
451. **Wiesenfeld HC, Hillier SL, Krohn MA, Amortegui AJ, Heine RP, Landers DV, Sweet RL**, Lower genital tract infection and endometritis: insight into subclinical pelvic inflammatory disease, *Obstet Gynecol* 100:456, 2002.
452. **Quinn PA, Shewchuk AB, Shuber J, Lie KI, Ryan E, Chipman ML, Nocilla DM**, Efficacy of antibiotic therapy in preventing spontaneous pregnancy loss among couples colonized with genital mycoplasmas, *Am J Obstet Gynecol* 145:239, 1983.
453. **Munday PE, Porter R, Falder PF, Carder JM, Holliman R, Lewis BV, Taylor-Robinson D**, Spontaneous abortion—an infectious aetiology? *Br J Obstet Gynaecol* 91:1177, 1984.
454. **Toth A, Lesser ML, Brooks-Toth CW, Feiner C**, Outcome of subsequent pregnancies following antibiotic therapy after primary or multiple spontaneous abortions, *Surg Gynecol Obstet* 163:243, 1986.
455. **Wacholder S, Chen BE, Wilcox A, Macones G, Gonzalez P, Befano B, Hildesheim A, Rodriguez AC, Solomon D, Herrero R, Schiffman M; CVT Group**, Risk of miscarriage with bivalent vaccine against human papillomavirus (HPV) types 16 and 18: pooled analysis of two randomised controlled trials, *Br Med J* 340:c712, 2010. doi:10.1136/bmj.c712.
456. **Harlap S, Shiono PH**, Alcohol, smoking, and incidence of spontaneous abortions in the first and second trimester, *Lancet* 2:173, 1980.
457. **Armstrong BG, McDonald AD, Sloan M**, Cigarette, alcohol, and coffee consumption and spontaneous abortion, *Am J Public Health* 82:85, 1992.
458. **Hughes EG, Brennan BG**, Does cigarette smoking impair natural or assisted fecundity, *Fertil Steril* 66:679, 1996.
459. **Himmelberger DU, Brown BW Jr, Cohen EN**, Cigarette smoking during pregnancy and the occurrence of spontaneous abortion and congenital abnormality, *Am J Epidemiol* 108:470, 1978.
460. **Hemminki K, Mutanen P, Saloniemä I**, Smoking and the occurrence of congenital malformations and spontaneous abortions: multivariate analysis, *Am J Obstet Gynecol* 145:61, 1983.
461. **Windham GC, Swan SH, Fenster L**, Parental cigarette smoking and the risk of spontaneous abortion, *Am J Epidemiol* 135:1394, 1992.
462. **Kline J, Stein ZA, Susser M, Warburton D**, Smoking: a risk factor for spontaneous abortion, *N Engl J Med* 297:793, 1977.

463. **Coste J, Job-Spira N, Fernandez H**, Risk factors for spontaneous abortion: a case-control study in France, *Hum Reprod* 6:1332, 1991.
464. **Gardella JR, Hill JA III**, Environmental toxins associated with recurrent pregnancy loss, *Semin Reprod Med* 18:407, 2000.
465. **Streissguth AP, Martin DC, Martin JC, Barr HM**, The Seattle longitudinal prospective study on alcohol and pregnancy, *Neurobehav Toxicol Teratol* 3: 223, 1981.
466. **Kline J, ShROUT P, Stein Z, Susser M, Warburton D**, Drinking during pregnancy and spontaneous abortion, *Lancet* 2:176, 1980.
467. **Cavallo F, Russo R, Zotti C, Camerlengo A, Ruggenini AM**, Moderate alcohol consumption and spontaneous abortion, *Alcohol* 30:195, 1995.
468. **Srisuphan W, Bracken MB**, Caffeine consumption during pregnancy and association with late spontaneous abortion, *Am J Obstet Gynecol* 154:14, 1986.
469. **Kline J, Levin B, Silverman J, Kinney A, Stein Z, Susser M, Warburton D**, Caffeine and spontaneous abortion of known karyotype, *Epidemiology* 2:409, 1991.
470. **Infante-Rivard C, Fernandez A, Gauthier R, David M, Rivard GE**, Fetal loss associated with caffeine intake before and during pregnancy, *JAMA* 270:2940, 1993.
471. **Fenster L, Hubbard AE, Swan SH, Windham GC, Waller K, Hiatt RA, Benowitz N**, Caffeinated beverages, decaffeinated coffee, and spontaneous abortion, *Epidemiology* 8:515, 1997.
472. **Dlugosz L, Belanger K, Hellenbrand K, Holford TR, Leaderer B, Bracken MB**, Maternal caffeine consumption and spontaneous abortion: a prospective cohort study, *Epidemiology* 7:250, 1996.
473. **Rasch V**, Cigarette, alcohol, and caffeine consumption: risk factors for spontaneous abortion, *Acta Obstet Gynecol Scand* 82:182, 2003.
474. **Parazzini F, Chatenoud L, Di Cintio E, Mezzopane R, Surace M, Zanconato G, Fedele L, Benzi G**, Coffee consumption and risk of hospitalized miscarriage before 12 weeks of gestation, *Hum Reprod* 13:2286, 1998.
475. **Wen W, Shu XO, Jacobs DR Jr, Brown JE**, The associations of maternal caffeine consumption and nausea with spontaneous abortion, *Epidemiology* 12:38, 2001.
476. **McMartin KI, Chu M, Kopecky E, Einarson TR, Koren G**, Pregnancy outcome following maternal organic solvent exposure: a meta-analysis of epidemiologic studies, *Am J Ind Med* 34:288, 1998.
477. **Schnorr TM, Grajewski BA, Hornung RW, Thun MJ, Egeland GM, Murray WE, Conover DL, Halperin WE**, Video display terminals and the risk of spontaneous abortion, *N Engl J Med* 324:727, 1991.
478. **Lammer EJ, Chen DT, Hoar RM, Agnish ND, Benke PJ, Braun JT, Curry CJ, Fernhoff PM, Grix AW Jr, et al.**, Retinoic acid embryopathy, *N Engl J Med* 313:837, 1985.
479. **Heidam LZ**, Spontaneous abortions among laboratory workers, *J Epidemiol Community Health* 38:36, 1984.
480. **Taskinen H, Lindbohm ML, Hemminki K**, Spontaneous abortions among women working in the pharmaceutical industry, *Br J Ind Med* 43:199, 1984.
481. **Belanger K, Leaderer B, Hellenbrand K, Holford TR, McSharry J, Power M-E, Bracken MB**, Spontaneous abortion and exposure to electric blankets and heated water beds, *Epidemiology* 9:36, 1998.
482. **Metwally M, Ong MKJ, Ledger WL, Li TC**, Does high body mass index increase the risk of miscarriage after spontaneous and assisted conception? A meta-analysis of the evidence, *Fertil Steril* 90:714, 2008.
483. **Zhang BY, Wei YS, Niu JM, Li Y, Miao ZL, Wang ZN**, Risk factors for unexplained recurrent spontaneous abortion in a population from southern China, *Int J Gynaecol Obstet* 108:135, 2010.
484. **Metwally M, Saravelos SH, Ledger WL, Li TC**, Body mass index and risk of miscarriage in women with recurrent miscarriage, *Fertil Steril* 94:290, 2010.
485. **Goldenberg RL, Mayberry SK, Copper RL, Dubard MB, Hauth JC**, Pregnancy outcome following a second-trimester loss, *Obstet Gynecol* 81:444, 1993.
486. **Perino A, Vassiliadis A, Vucetich A, Colacurci N, Menato G, Cignitti M, Semprini AE**, Short-term therapy for recurrent abortion using intravenous immunoglobulins: results of a double-blind placebo-controlled Italian study, *Hum Reprod* 12:2388, 1997.
487. **Fedele L, Acala B, Parazzini F, Ricciardiello O, Cantiani GB**, Ectopic pregnancy and recurrent

spontaneous abortion: two associated reproductive failures, *Obstet Gynecol* 73:206, 1989.

488. **Goldstein P, Berrier J, Rosen S, Sacks HS, Chalmers TC**, A meta-analysis of randomized control trials of progestational agents in pregnancy, *Br J Obstet Gynaecol* 96:265, 1989.
489. **Daya S**, Efficacy of progesterone support for pregnancy in women with recurrent miscarriage. A meta-analysis of controlled trials, *Br J Obstet Gynaecol* 96:275, 1989.
490. **Marzetti L, Boni T, Fazio M, Giobbe M**, Current role of progesterone therapy in the prevention of spontaneous abortion and in the treatment of threatened abortion, *Minerva Ginecol* 52:515, 2000.

# Genetics

The above DNA sequence is obviously a mutant. But the fact that we can recognize this cryptogram as a nucleotide sequence and diagnose a mutant change illustrates the incredible progress made in the understanding of human biology. Molecular genetics is the subspecialty of science devoted to understanding the structure and function of the genome, the full complement of DNA (deoxyribonucleic acid), the macromolecule that contains all the hereditary information.

The Austrian monk Gregor Mendel studied his garden of peas for much of his life at his monastery and was the first to express the principles of heredity in the 1860s. He described dominant and recessive traits and the “laws” of transmission governing the homozygous and heterozygous inheritance of these traits. Mendel’s theories remained unknown until 1900, when they were discovered 16 years after his death. But how far we have come in only 150 years, mostly in the last 50 years!

The pairing and splitting of chromosomes at cell division was proposed in 1903, but it was not until 1946 that Edward Tatum and Joshua Lederberg at Yale University demonstrated in bacteria that DNA carried hereditary information. James Watson and Francis Crick, working at the Cavendish Laboratories in Cambridge, proposed in 1953 the structure of DNA by creating a model based on the parameters provided by Maurice Wilkins and Rosalind Franklin obtained with x-ray crystallography. Crick, Watson, and Wilkins received the Nobel Prize in 1962 (Franklin had died in 1958, and the Nobel Prize is not awarded posthumously).

DNA replication involves many enzyme systems. DNA polymerase was isolated in 1958, and ribonucleic acid (RNA) polymerase in 1960. In 1978, Werner Arber, Hamilton Smith, and Daniel Nathans received the Nobel Prize for their discovery, in the 1960s, of the enzymes for joining or cutting DNA. The use of ligase and restriction endonuclease enzymes permitted the production of recombinant DNA molecules, first accomplished by Paul Berg at Stanford University in 1972.

E.M. Southern of Edinburgh University developed in 1975 the technique to transfer (to blot) DNA from agarose gels onto nitrocellulose filters, enabling DNA fragments to be joined with radiolabeled RNA probes and thus isolated. The cloning of genes or DNA fragments followed the breakthrough discovery that plasmids carrying foreign DNA molecules could be inserted into bacteria, leading to the replication of the foreign DNA.

Through the subsequent development of techniques such as rapid DNA sequencing by Frederick Sanger in 1973 and the polymerase chain reaction (PCR) (attributed to Kary Mullis in 1983), gene discovery and characterization became easier. Soon, full genomes (the complete sets of DNA for entire organisms) were able to be sequenced. The first eukaryotic species to have a fully sequenced genome was the yeast *Saccharomyces cerevisiae*, completed in 1996, followed by many other model organisms and culminating with the Human Genome Project (completed in 2003).

Advances in molecular genetics have revolutionized much of modern medicine, but few specialties have been impacted as much as reproductive endocrinology. From the identification of gene variants that increase the risk of reproductive abnormalities to the broad utilization of preimplantation genetic testing for recurrent and sporadic genetic abnormalities in cultured embryos, a fundamental knowledge of molecular genetics is essential to the modern reproductive endocrinologist. We offer this chapter as a guide to molecular genetics. The purpose of this chapter, therefore, is not to present an intensive course in the basic sciences but rather to review the most important principles and information necessary for clinical practice today.

# AN OVERVIEW OF THE HUMAN GENOME

---

The genome for each species consists of the complete set of DNA sequences on all the chromosomes. There are nearly 3 billion base-pairs in each haploid human genome, and an estimated 20,000–25,000 genes. Representing the smallest functional unit of inherited information, a gene is a contiguous region of DNA that can encode a protein product and contains within its area regulatory sequences that govern its expression. Genes account for only about 2% of human DNA. Although enormously complex at first glance, the entire genetic language is written with only four letters: A, C, G, and T (U in RNA). Furthermore, the language is limited to only three-letter words, known as codons. With four nucleotides, reading groups of three, there are 64 possible combinations. Essentially all living organisms use this code. The genome changes only by new combinations derived from parents or by mutation ([Table 31.1](#)). Finally, the linear arrangement of the entire genome is fragmented into the 23 pairs of chromosomes.

## TABLE 31.1 The mRNA Genetic Code



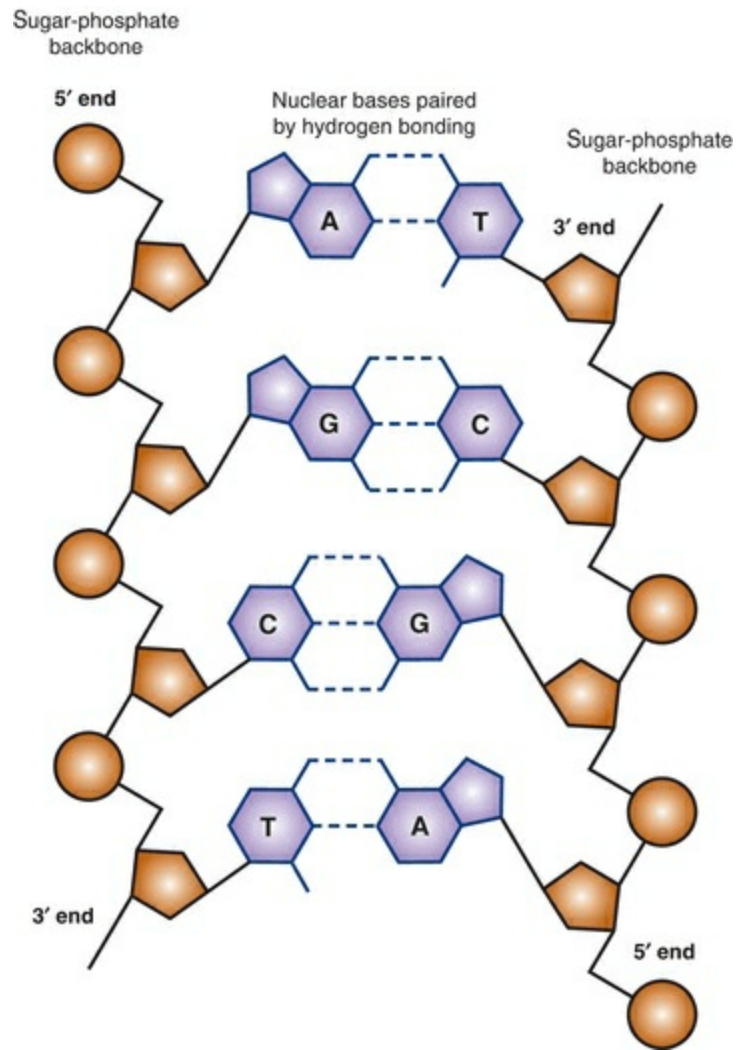
First Position (5' End)	Second Position				Third Position (3' End)
	U	C	A	G	
U	Phe	Ser	Tyr	Cys	U
	Phe	Ser	Tyr	Cys	C
	Leu	Ser	Stop	Stop	A
	Leu	Ser	Stop	Trp	G
C	Leu	Pro	His	Arg	U
	Leu	Pro	His	Arg	C
	Leu	Pro	Gln	Arg	A
	Leu	Pro	Gln	Arg	G
A	Ile	Thr	Asn	Ser	U
	Ile	Thr	Asn	Ser	C
	Ile	Thr	Lys	Arg	A
	Met	Thr	Lys	Arg	G
G	Val	Ala	Asp	Gly	U
	Val	Ala	Asp	Gly	C
	Val	Ala	Glu	Gly	A
	Val	Ala	glu	Gly	G

# The Structure and Function of DNA

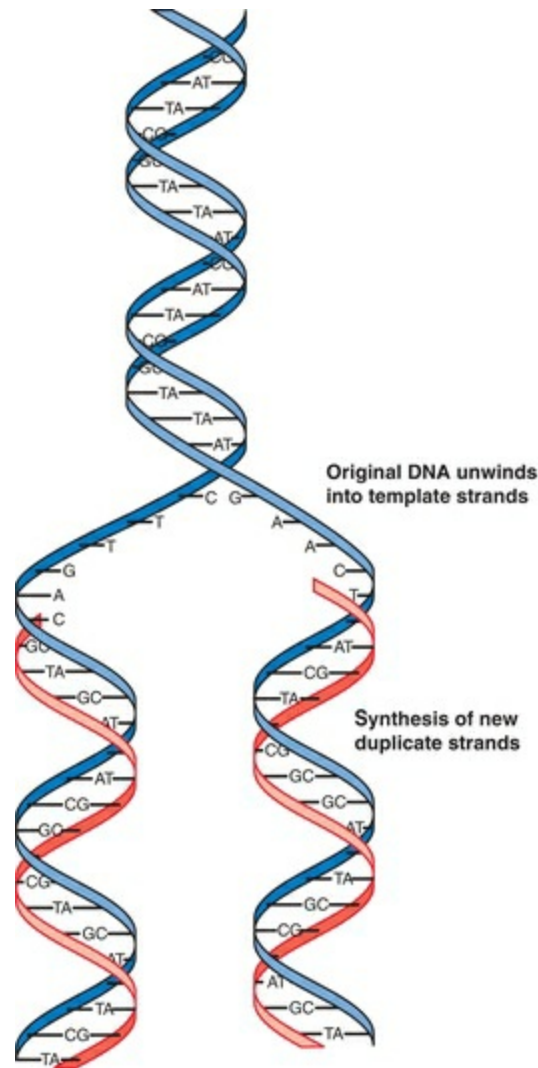
DNA is the material of the gene responsible for coding the genetic message as transmitted through specific proteins. Thus, it is the most important molecule of life and the fundamental mechanism for evolution. Genes are segments of DNA that code for specific proteins, together with flanking and intervening sequences that serve controlling and regulating functions. Each molecule of DNA has a deoxyribose backbone, identical repeating groups of deoxyribose sugar linked through phosphodiester bonds. Each deoxyribose is attached in order (giving individuality and specificity) to one of four nucleic acids, the nuclear bases:

- A purine—adenine or guanine
- A pyrimidine—thymine or cytosine

A nucleotide is the basic building block of DNA. It consists of three major components: the deoxyribose sugar, a phosphate group, and a nucleic acid base. The phosphate-sugar (**Figures 31.1** and **31.2**) linkages are asymmetric; the phosphorus is linked to the 5-carbon of one sugar and to the 3-carbon of the following sugar. Thus, one end is the 5' (5 prime) end and the other the 3' (3 prime) end. By convention, DNA and its nuclear acid sequences are written from left to right, from the 5' end to the 3' end, which is the direction of the transcription process. The 5' end leads to the formation of the amino end of the protein, while the 3' end forms the carboxy end of the protein.



**FIGURE 31.1**



**FIGURE 31.2**

DNA consists of two deoxyribose strands twisted around each other clockwise in a double helix, with the nucleic acids on the inside and the nuclear bases paired by hydrogen bonding; adenine pairs with thymine, and cytosine pairs with guanine. RNA differs from DNA in that it is single stranded, its sugar moiety is ribose, and it substitutes uracil for thymine. Phoebus Levene, a Russian immigrant to the United States working at the Rockefeller Institute of Medical Research from 1905 until he died in 1940, identified the components of DNA (discovering and naming the ribose and deoxyribose sugars) and was the first to suggest the nucleotide structure, research that provided the foundation for the later delineation of the DNA's significance.

How can a cell's DNA, which stretched out measures nearly 2 m long, fit into a cell? Watson and Crick figured this out when they proposed a tightly coiled two-stranded helix, the double helix. Like the centimeter is a measure of length, the base pair (bp) is the unit of measure for DNA. The base pair is either adenine-guanine or

cytosine-thymine, the nucleic acid of one chain paired with the facing nucleic acid of the other chain. A fragment of DNA, therefore, is measured by the number of base pairs, for example, a 4,800-bp fragment (a 4.8 kb fragment). It is estimated that we have nearly 3 billion bp of DNA, only a small portion of which actually encodes proteins.

DNA does not exist within the cell as a naked molecule. The nucleotide chains wind about a core of proteins (histones) to form a nucleosome. The nucleosomes become condensed into many bands, which can be seen in karyotype preparations. This condensation is another important mechanism for packing the long DNA structure into a cell. Many other proteins are associated with DNA, important for both structure and function.

The process of DNA replication begins with a separation of the double-stranded DNA helix, initiated at multiple steps by enzyme action. As the original DNA unwinds into template strands, DNA polymerase catalyzes the synthesis of new duplicate strands, which re-form a double helix with each of the original strands (this is called replication). Each daughter molecule, therefore, contains one of the parental strands. It is estimated that the original DNA molecule present in the fertilized zygote must be copied approximately  $10^{15}$  times during the course of a human lifetime. Rapidity and accuracy are essential. By combining precision with error correction systems, errors that affect the function of the gene's protein are surprisingly rare ([Table 31.2](#)).

## **TABLE 31.2 The 20 Amino Acids in Proteins**

<b>Amino Acid</b>	<b>Three-letter Abbreviation</b>	<b>Single-letter Code</b>
Glycine	Gly	G
Alanine	Ala	A
Valine	Val	V
Isoleucine	Ile	I
Leucine	Leu	L
Serine	Ser	S
Threonine	Thr	T
Proline	Pro	P
Aspartic acid	Asp	D
Glutamic acid	Glu	E
Lysine	Lys	K
Arginine	Arg	R
Asparagine	Asn	N
Glutamine	Gln	Q
Cysteine	Cys	C
Methionine	Met	M
Tryptophan	Trp	W
Phenylalanine	Phe	F
Tyrosine	Tyr	Y
Histidine	His	H



# The Structure of Genes

A gene is composed of a segment of DNA containing exons separated by introns, which are coding and noncoding portions, respectively. Intron-exon patterns tend to be conserved during evolution. For instance, the alpha- and beta-globin genes are believed to have arisen 500 million years ago, with the introns in the same location as they are today.

## Exon

The segment of a gene that yields a messenger RNA (mRNA) product, which codes for a specific protein

## Intron

The segment of a gene not represented in mature RNA and, therefore, noncoding for protein, but capable of regulatory functions

## Codon

A triplet codon is a sequence of three bases in RNA or DNA that codes for a specific amino acid or translational end-point.

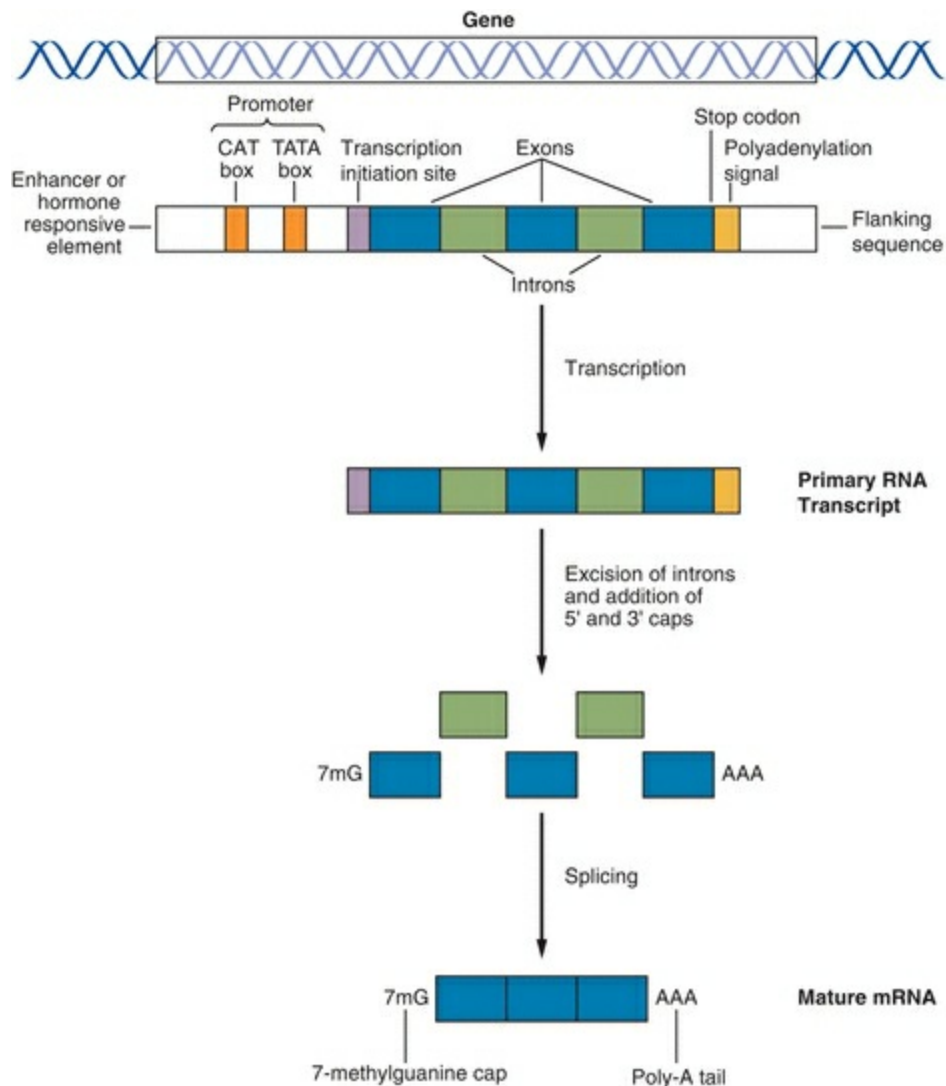
With some exceptions, it was believed that one gene yields only one protein. The one gene–one protein concept was first proposed in 1909 by Archibald Garrod and experimentally supported in the 1940s by George Beadle and Edward Tatum, American geneticists, by linking single-gene mutations to single-enzyme deficiencies. However, through a mechanism known as alternative splicing, the 20,000–25,000 human genes can produce more than 100,000 proteins. As noted above, the introns are not translated into protein products. Only the DNA sequences in the exons are transcribed into mRNA and then translated into proteins. However, variations (alternative splicing) can lead to selective inclusions of exons from a gene and produce related proteins.

Genes also include flanking sequences important for gene transcription. The area that will initiate DNA action (e.g., DNA binding to the hormone-receptor complex) is called an **enhancer** region. The actual area where transcription begins is the **promoter** region. Only a few relatively short nucleotide sequences are promoters, such as the T-A-T-A-A sequence, or TATA box, and the C-C-A-A-T sequence, or CAT box. The promoter sites (the binding sites for RNA polymerase and numerous cofactors) are usually near the start of the coding region of the gene. Enhancer sites are larger than promoter sites and can be located anywhere, even far from the gene, but usually are in the 5' flanking end. At the 3' end, a coding sequence is usually present for the



polyadenosine (poly-A) tail common for most mRNA molecules.

The enhancer sites bind regulatory proteins that serve as signals to regulate gene expression by either increasing or repressing the binding of RNA polymerase in the promoter region (**Figure 31.3**). This is one method of creating unique cellular functions. For example, a hormone target tissue can respond to the hormone because it contains a specific receptor protein that, on binding to the hormone, will bind to a DNA enhancer site. Specific proteins (called transcription factors) bind to enhancer sites and activate transcription. The regulation of gene transcription usually involves DNA sequences in the 5' flanking upstream region of a gene.



**FIGURE 31.3**

Genes that encode proteins contain a **start codon** (AUG), which begins the **open reading frame**, a segment of the gene that encodes the amino acid sequence of the gene

product. The open reading frame ends at a **stop codon** (UGA, UAA, or UAG), which specifies a stop to translation of RNA into protein (like a period at the end of a sentence). Finding and identifying an open reading frame is an important step in analyzing DNA sequences because such a long sequence is usually encountered only in an active gene.

# THE CHROMOSOMES

---

The linear arrangement of many genes forms a chromosome. Chromosomes are packages of genetic material, consisting of a DNA molecule to which are attached large numbers of proteins that maintain chromosome structure and play a role in gene expression. Human somatic cells contain 46 chromosomes (22 homologous pairs of autosomes and 2 sex chromosomes). All somatic cells are diploid, containing 23 pairs of chromosomes. Only gametes are haploid, with 22 autosomes and one sex chromosome. The chromosomes vary in size, ranging from 50 million to 250 million base pairs. Chromosome 1 contains the most protein-coding genes (2,044), and the Y chromosome has the smallest number (63). All contain a pinched portion called a centromere, which divides the chromosome into two arms, the shorter p arm and the longer q arm (in acrocentric chromosomes, the p arm is so small that it can hardly be seen on a karyotype, but it is still present). The two members of any pair of autosomes are homologous, one homologue derived from each parent. The number of chromosomes does not indicate the level of evolutionary sophistication and complexity; the dog has 78 chromosomes and the carp has 104!

A karyotype is an arrangement of the chromosomes into pairs, usually after proteolytic treatment and Giemsa staining to produce characteristic banding patterns, allowing a blueprint useful for location. The staining characteristics divide each arm into regions and each region into bands that are numbered from the centromere outward. A given point on a chromosome is designated by the following order: chromosome number, arm symbol (p for short arm, q for long arm), region number, and band number. For example, 7q31.1 (read as “seven-q-three-one-point-one,” **not** as “seven-q-thirty-one-point-one”) is the location for the cystic fibrosis gene, or its **gene locus**. Because there are 22 pairs of autosomes, most genes exist in pairs. The pairs are homozygous when similar and heterozygous when dissimilar.

# Mitosis

Bacteria are **prokaryotes**, organisms without a true nucleus, with reproduction by cell division. In contrast, humans are **eukaryotes**, organisms with cells having a true nucleus bounded by a nuclear membrane. All eukaryotes, from yeasts to humans, undergo similar cell division and multiplication. The process of nuclear division in all somatic cells is called mitosis, during which each chromosome divides into two. For normal growth and development, the entire genomic information must be faithfully reproduced in every cell.

Mitosis consists of the following stages:

## Interphase

During this phase, all normal cell activity occurs except active division. It is during this stage that the inactive X chromosome (the Barr body or the sex chromatin) can be seen in female cells. DNA replication happens during interphase, in preparation for cell division.

## Prophase

Before replication, one chromosome is composed of one DNA molecule. Following replication, the two of a replicated chromosome are called chromatids. During the later stages of cell division, these chromatids separate longitudinally to become individual chromosomes. Chromatids may be sister or nonsister chromatids. A sister chromatid is either one of the two chromatids of the same chromosome joined together by a common centromere. As division begins, the chromosomes condense, and the two chromatids become visible. The nuclear membrane disappears. The centriole is an organelle outside the nucleus that forms the spindles for cell division; the centriole duplicates itself, and the two centrioles migrate to opposite poles of the cell.

## Metaphase

The chromosomes migrate to the center of the cell, forming a line designated the equatorial plate. The chromosomes are now maximally condensed. The spindle, microtubules of protein that radiate from the centrioles and attach to the centromeres, is formed.

## Anaphase

Division occurs in the longitudinal plane of the centromeres. The two new chromatids move to opposite sides of the cell drawn by contraction of the spindles.

## **Telophase**

Division of the cytoplasm begins in the equatorial plane, ending with the formation of two complete cell membranes. The two groups of chromosomes are surrounded by nuclear membranes forming new nuclei.

# Meiosis

Meiosis is the cell division that forms the gametes, each with a haploid number of chromosomes. Meiosis has two purposes: **reduction** of the chromosome number and **recombination** to transmit genetic information and to promote genetic diversity. Before **meiosis** begins, during S phase of the cell cycle, the DNA of each chromosome is **replicated** so that it consists of two sister chromatids. The two **meiotic** divisions are known as **meiosis I** and **meiosis II**. In meiosis I, homologous chromosomes pair and split apart, each consisting of two sister chromatids. Meiosis II is similar to mitosis, where sister chromatids split and segregate into new cells.

## The First Meiotic Division (Meiosis I)

### Prophase

- **Leptotene: Condensation of the chromosomes.**
- **Zygotene: Pairing of homologous chromosomes (synapsis).**
- **Pachytene: Each pair of chromosomes thickens to form four strands.**

This is the stage in which **crossing over** or **recombination** can occur (DNA exchange of homologous segments between two of the four strands). Chiasmata are the places of contact where crossovers occur (and can be visualized). This movement of blocks of DNA is a method for creating genetic diversity. On the other hand, genetic diseases can result from the insertion of sequences during gametogenesis.

- **Diplotene: Longitudinal separation of each chromosome.**

This is the stage of meiosis where oocytes become arrested in the gonads of a female fetus and remain arrested until the time of ovulation in a postpubertal female. In the male, meiosis starts only after puberty and occurs without an arrest.

### Metaphase, Anaphase, and Telophase of Meiosis I

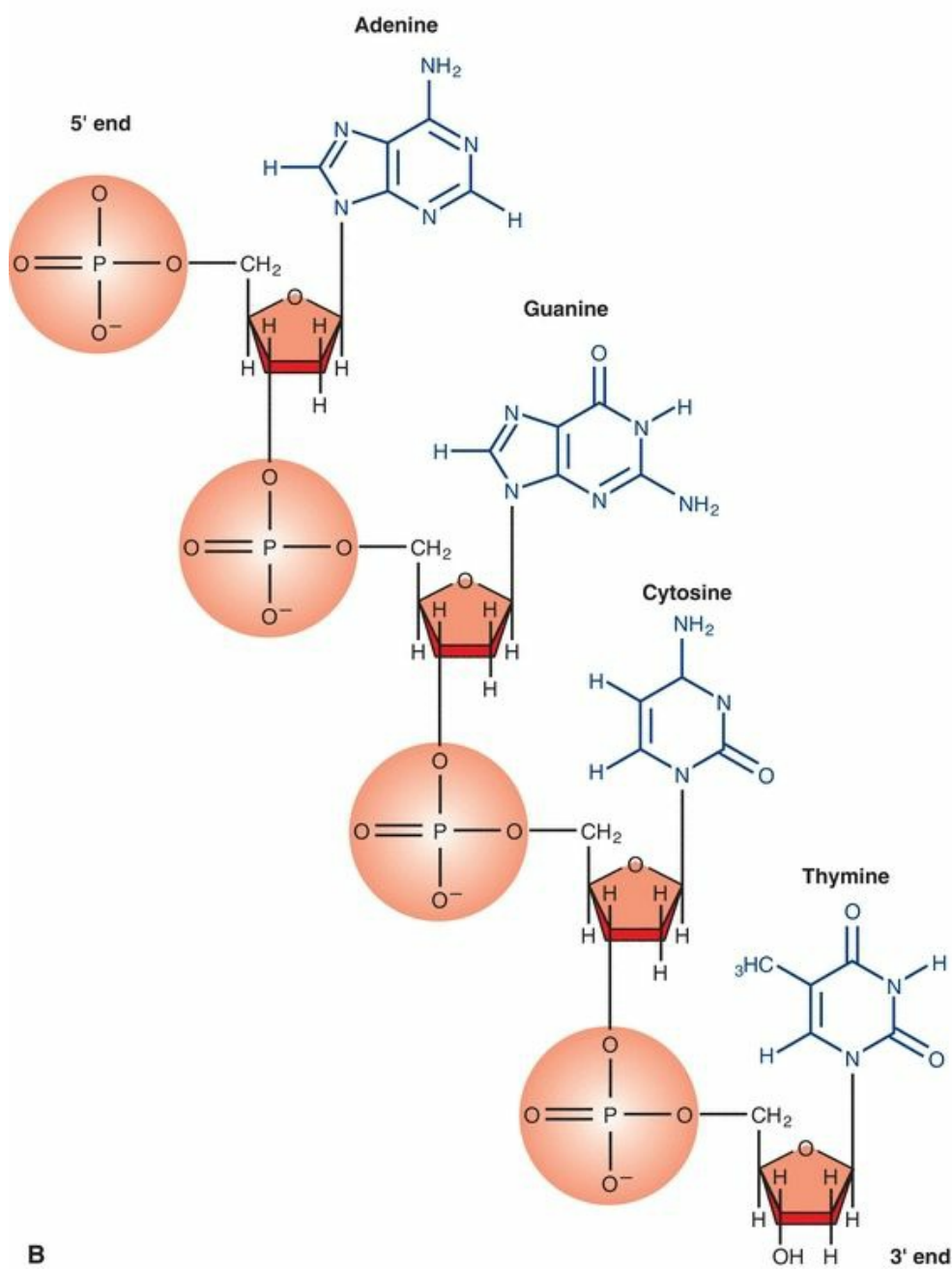
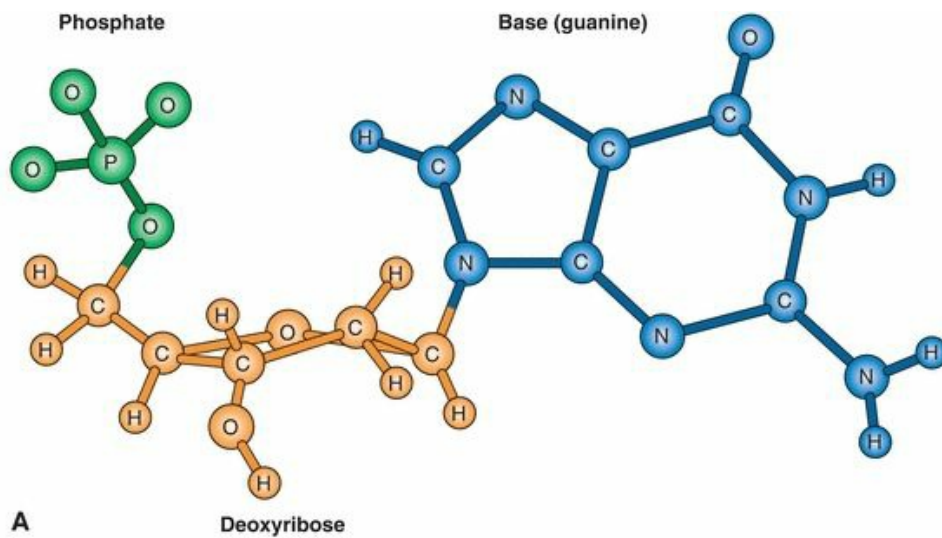
Humans are diploid meaning that most of their chromosomes come in matched sets known as homologous pairs. The 46 chromosomes of a human cell are organized into 23 pairs, and the two members of each pair are said to be homologues of one another.

The nuclear membrane disappears, and the chromosomes move to the center of the cell. One member of each homologous pair goes to each pole, and the cells divide. In oogenesis, the cell division results in one secondary oocyte and the first polar body, a haploid cell that is smaller than the oocyte and is unable to be fertilized.

Meiosis I is often referred to as reduction division because each new product now has the haploid chromosome number (containing only one of each homologous pair). It is during the first meiotic division that Mendelian inheritance occurs. Crossovers that occur prior to metaphase result in new combinations of genetic material, both favorable and unfavorable.

## **The Second Meiotic Division (Meiosis II)**

The second division follows the first without DNA replication. The end result is the production of four haploid cells. In the developing oocyte, meiosis II arrests at metaphase II and then continues after fertilization. After fertilization, the second polar body is extruded and the fertilized mature oocyte remains ([Figure 31.4](#)).





## FIGURE 31.4

# Gene Function

While the structure of DNA, genes, and chromosomes help us to understand their composition and replication, the power of these structures comes from the functions they encode. Gene expression is composed of the following steps: transcription of DNA to RNA, RNA processing to produce functional mRNA, translation of mRNA on a ribosome to a peptide chain, and protein structural processing to the functional form.

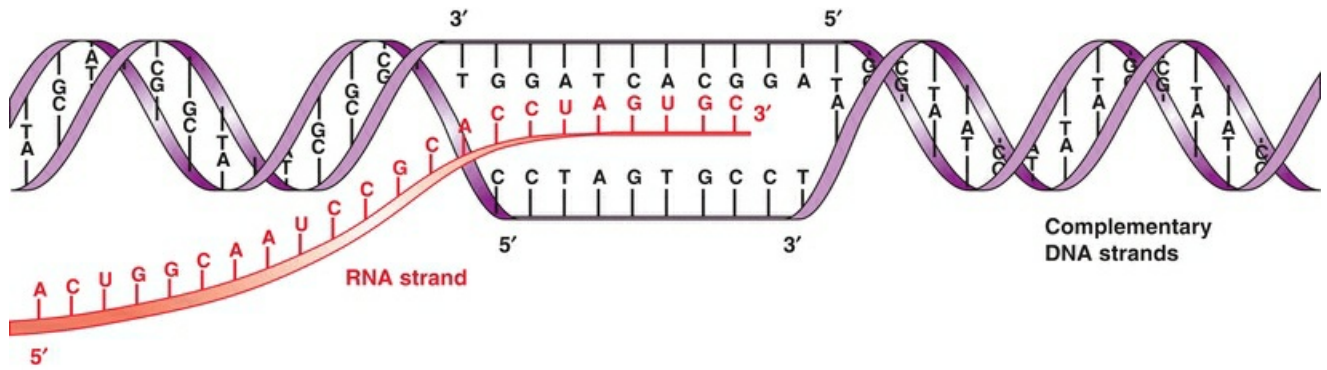
## Transcription

Transcription is the synthesis of single-stranded mRNA from a gene (double-stranded DNA). The amino acid sequence of the protein is coded in the DNA, where a single amino acid is encoded by each triplet codon. RNA polymerase constructs the mRNA by reading the DNA strand (the “antisense” strand) that is complementary to the RNA; thus, the RNA is an exact copy of the other DNA strand (the “sense” strand), which is also called the complementary strand of the DNA molecule (remember, two important differences are that thymine in DNA is replaced by uracil and ribose replaces deoxyribose in RNA).

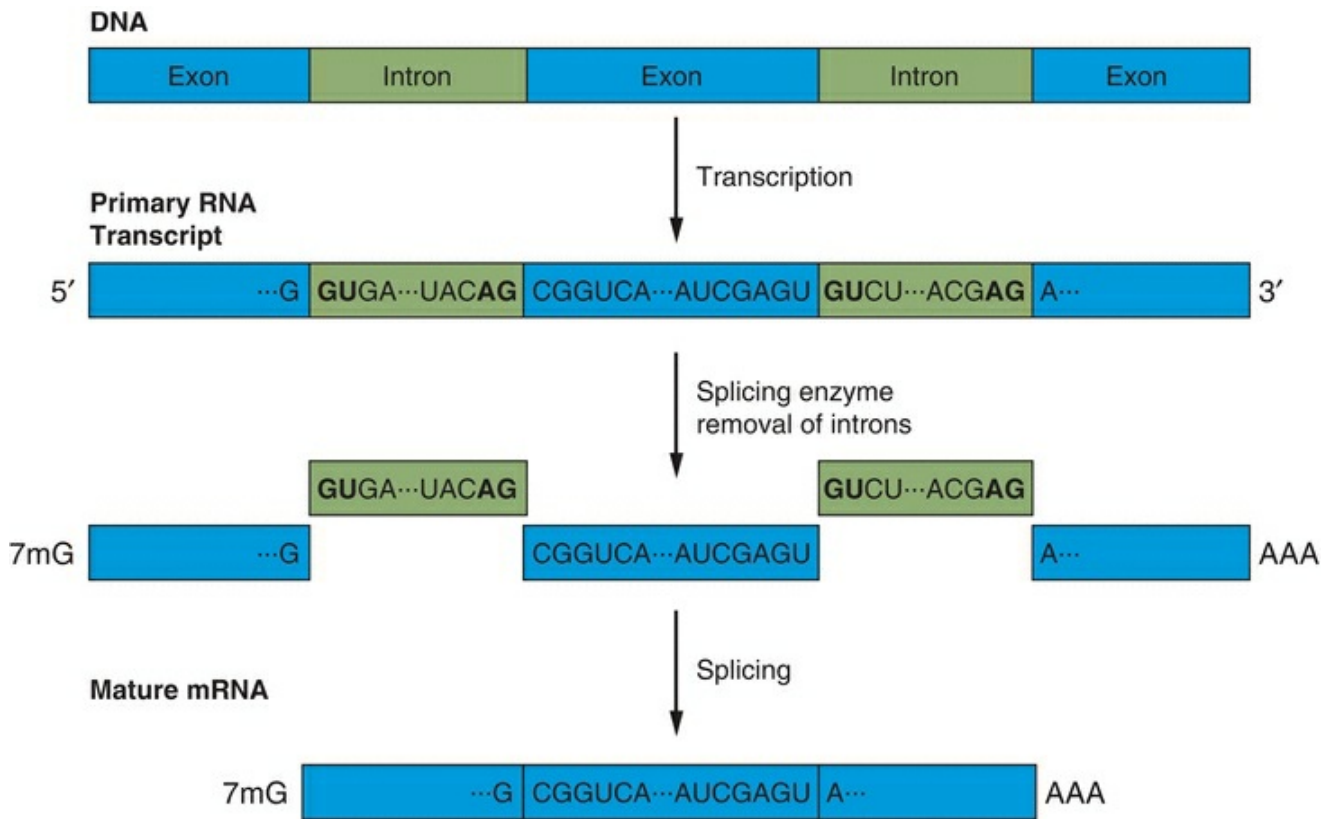
Molecular complementarity is both a difficult and a simple concept to grasp. The simple aspect is the concept of one thing being like another. The difficult part is the necessity to understand and visualize that the complementary molecule is not identical to its template. Thus, the strands of the double helix are not identical. Each DNA strand has a complementary structure, in a sense, one positive template and one negative template, each specifying the other. Each strand, therefore, serves as a template for its complementary DNA (in the process of replication) or complementary RNA (in the process of transcription). Thus, mRNA is synthesized from the negative template, the “antisense” strand, so that it will have the same structure as the positive template, the “sense” strand. Molecular biologists have to think in three dimensions!

Transcription is initiated at the upstream start site, the 5' untranslated flanking region where the two strands of the double helix come apart. The process continues downstream, copying one of the strands until a terminator signal is reached. Once the mRNA is synthesized, it undergoes further processing in the nucleus, with the addition of a 5' cap (a modified nucleotide, 7-methyl guanosine) and a 3' the poly-A tail (long chain of adenines), which stabilize the mRNA by protecting against degradation and facilitate translation. In addition, the intronic regions are excised and the exons are joined together in a process called **RNA splicing**. The start and end of each exon and intron have sequences that, when copied onto the RNA, signal an enzyme to remove the intervening parts. Almost all introns begin with GU and end with AG (GT and AG in the DNA intron). Introns are of varying lengths; a single intron can be longer than the final RNA product. Following capping, tailing, and splicing, the mRNA is ready to be

transported to the cytoplasm (**Figures 31.5** and **31.6**).



**FIGURE 31.5**



**FIGURE 31.6**

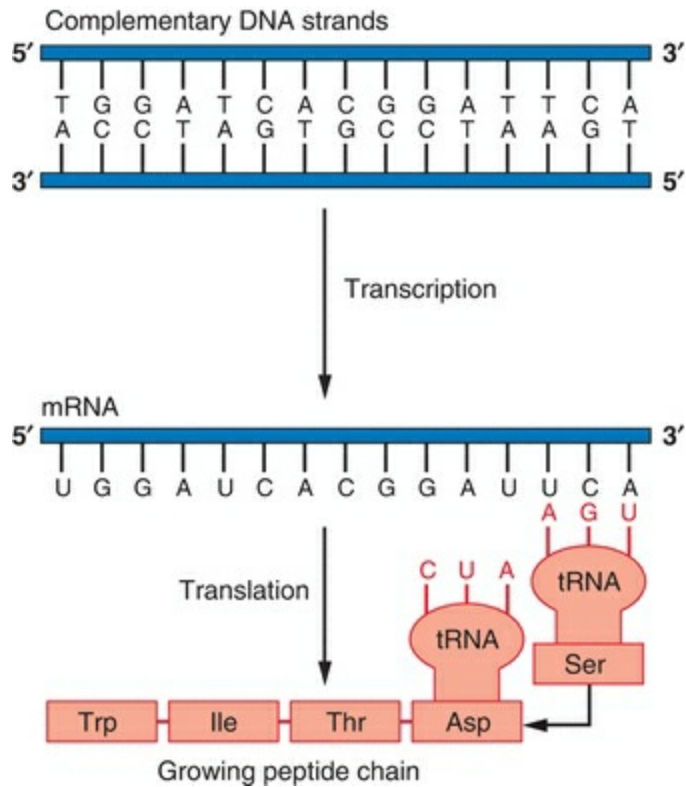
## Transcription Factors

Transcription factors are proteins that bind to regulatory elements in DNA (enhancers and promoters) and thus influence gene expression. For instance, the steroid hormone receptors are transcription factors. Gene transcription and the formation of mRNA can

be either stimulated or inhibited through direct interactions with DNA. Transcription factors can further interact with other factors (coactivators and corepressors, also called adapter proteins) to produce cooperative effects. The activity of these proteins can also be affected by phosphorylation triggered by signals from cell-surface receptors (often growth factors). An important concept is to view the final result of hormonal activity and gene expression as a reflection of **cellular context**, the nature and activity of transcription factors as influenced by specific intracellular adapter proteins. This explains how similar agents (and similar transcription factors, e.g., the estrogen receptor) can have different actions in different tissues.

## Translation

The mRNA travels from the nucleus to the cytoplasm, where it directs the assembly of amino acids into proteins (translation) on ribosomes. Each cell has a characteristic but dynamic and always changing **proteome**, the collection of proteins unique for that cell. Amino acids are brought into the process by specific transfer RNA molecules. The specific sequence of three bases at one end of the transfer RNA is complementary to the codon that encodes the specific amino acid. Binding of this area to the mRNA codon places the specific amino acid at the other end into the proper sequence for the protein. The amino acids are placed one at a time as the transfer RNA molecules read the RNA template, beginning at the amino end and finishing at the carboxy end. The process begins at the first AUG triplet and continues until a stop codon (UAA, UAG, or UGA) is reached, whereupon the mRNA falls off the ribosome and degenerates (**Figure 31.7**). The specific linear sequence of amino acids is specified by the genetic coding; in turn, this sequence determines the 3-dimensional form of the protein, the folded structure necessary for function. There are only 20,000–25,000 protein-encoding human genes, but there are more than 100,000 proteins. Obviously a single gene can produce more than one protein, primarily through the process of alternative splicing.



**FIGURE 31.7**

The final expression of a gene may not end with the translation process. Further posttranslational processing of proteins occurs, such as glycosylation (such as for the gonadotropins) or proteolytic cleavage (as happens in the conversion of proopiomelanocortin to ACTH).

In the discussion of regulation of gene expression and translation, micro RNAs (miRNAs) are worth mentioning. miRNAs are 21–22 nucleotide long noncoding mRNAs that repress expression of targeted genes through sequence complementarity, resulting in the degradation of target mRNAs or (more commonly) inhibition of their translation. More than 1,500 evolutionarily conserved miRNAs have been identified and play key roles in physiologic processes as well as pathogenesis of reproductive disorders.

**The mechanisms that produce proteins from genes are similar throughout the biologic world. This means that important knowledge regarding human function can be gained by studying simple organisms, and microbes can be engineered to produce human proteins.**

## Epigenetics

Epigenetics is the study of heritable changes in gene expression that do not involve

changes in DNA sequence. Epigenetic regulation may occur through DNA methylation or by alterations to the histone proteins that are responsible for the overall structure of chromatin. The best characterized DNA methylation process is the covalent addition of the methyl group at the 5-carbon of the cytosine ring resulting in 5-methylcytosine (5-mC). These methyl groups project into the major groove of DNA and inhibit transcription. Although epigenetic modifications do not result in changes to the DNA sequence or the content of genes and chromosomes, they have significant effects on gene function and the resulting phenotype.

# GENETIC AND EPIGENETIC VARIATION

---

The content of an organism's genetic and epigenetic information determines the subsequent functions that they encode. Therefore, genetic and epigenetic variation are both causes of diversity among members of the same species, as well as mechanisms of genetic risk and disease. Variation can arise anew (de novo) via mutation or can be inherited from a parent. Historically, the term "mutation" suggested a pathogenic change, but mutations can also have a phenotypic benefit to an individual. Some suggest the use of the term mutation for rare variants in the population, while using the term polymorphism for those variants with a population frequency greater than 1%. However, some rare variants have no apparent functional consequence and are better characterized simply as rare or private variants. Although there is some dispute over when the term mutation is appropriate, for the purposes of this text, we will reflect the most common usage of the term as a genetic lesion responsible for heritable human disease.

Genetic variation and mutation can occur at the level of a single nucleotide, a portion of a gene, a segment of a chromosome, or an entire chromosome or set of chromosomes. Understanding genetic and epigenetic variation is essential for today's reproductive endocrinologist.

# Single-Gene Sequence Variation

Many genes exist in various forms, called alleles. A change in DNA sequence that results in a change in protein structure or function that is harmful constitutes a pathogenic variant or mutation. Substitution refers to a change in a single nucleotide. Due to redundancy in the genetic code (i.e., there are multiple codons that encode a single amino acid), synonymous single-nucleotide variants do not manifest in changes to the gene product. However, a nonsynonymous substitution in a codon results in the incorporation of the wrong amino acid into a protein, leading to a change or loss in function. A clinical example of such a change is the sickle-cell mutation, in which thymine is substituted for adenine in the beta-globin gene, resulting in the well-known phenotype. Single-base substitutions can also occur within a gene's promoter (thus altering gene expression) or at a splice site (thereby preventing appropriate mRNA splicing and resulting in an altered downstream amino acid sequence), or can even introduce a premature stop codon (causing a truncated protein to be expressed).

If homologous regions of DNA are misaligned, unequal crossover can occur, resulting in deletions and insertions. Deletions and insertions can be as small as single nucleotides or as large as genes or several genes. Single-gene deletions and insertions are commonly referred to as indels. The content and location of such indels dictates their functional impact; for instance, a three-base-pair "in-frame" (i.e., falling between one codon and the next in a sequence) insertion may not have a large impact, but a single base-pair deletion would cause a "frameshift" (i.e., changing the reading frame for every subsequent codon in the gene) and would be very likely to be pathogenic.

Single-gene mutations are generally transmitted according to mendelian inheritance patterns: autosomal dominant, autosomal recessive, X-linked recessive, and rarely X-linked dominant. In autosomal dominant conditions, one abnormal allele for a given gene is all that is needed to yield the disordered phenotype. With two heterozygous parents, each child has a 75% risk of being affected. With one heterozygous parent, each child has a 50% risk of being affected. Examples of autosomal-dominant conditions include Huntington disease, neurofibromatosis, and Marfan syndrome. The effect of an abnormal dominant gene is influenced by **penetrance**, the degree the dominant gene is expressed. Complete penetrance, as opposed to incomplete penetrance, means that the gene is always expressed and always produces a recognizable phenotype.

In contrast, autosomal recessive conditions are phenotypically expressed only in homozygotes where both alleles are abnormal. A child of heterozygote parents has a 25% risk of being affected and a 50% chance of being a heterozygote ("carrier"). Examples of autosomal recessive conditions are cystic fibrosis, sickle cell disease, and congenital adrenal hyperplasia due to a deficiency in 21-hydroxylase. Similarly, X-linked recessive conditions are only seen when there is no normal allele present. In



females, this would require homozygosity for the variant allele. However, in males, the lack of a second X chromosome ensures that all who have the variant allele will manifest the phenotype. Thus, each son of a female carrier has a 50% chance of being affected and each daughter a 50% chance of being a carrier. Red-green color blindness and hemophilia A are examples.

A final type of single-gene mutations worth discussing is mitochondrial DNA mutations. Mitochondria are believed to be descendants of primitive bacteria engulfed by our ancestors, and they still contain some important genes. Each mitochondrion is estimated to contain 2–10 mtDNA copies and with the exception of oocytes and spermatozoa, 100–10,000 copies of mtDNA are estimated to be present in human cells. In mammals, each double-stranded circular mtDNA molecule consists of 15,000–17,000 base pairs, encoding a total of 37 genes. Of these, 13 encode proteins involved in electron transport chain, while the remainders are for ribosomal RNAs (2) or transfer RNAs (22). The mitochondria in sperm are eliminated during fertilization, so there is no paternal transmission of mitochondrial DNA mutations and diseases due to mitochondrial genes (e.g., Leber optic neuropathy) are solely transmitted by the mother.

# Polygenic Traits and Disorders

While single-gene variation can manifest in disease or individual diversity, many genetic traits and disorders are the result of a combination of genetic effects. Polygenic traits, such as height or eye color, are determined by the combined effect of different alleles at multiple genetic loci. Multifactorial genetic disorders result from a number of genetic variants, which, often in combination with environmental effects, can increase the risk of pathology. Most common diseases with a genetic component, such as coronary artery disease and polycystic ovary syndrome, are multifactorial. Additionally, there are some genetic diseases that derive from a specific subset of genetic mutations. Best described are cancers that arise in the setting of coexisting mutations in two genes, popularly known as the “two-hit hypothesis” of carcinogenesis.

# Chromosomal Abnormalities

## Numerical Abnormalities

Numerical abnormalities usually are due to nondisjunction, a failure of separation at anaphase, either during mitotic division or during meiosis. **Aneuploidy** is a chromosome number that is not an exact multiple of the haploid number, for example, monosomy (45,X Turner syndrome) or trisomy (trisomy 13 Patau syndrome, trisomy 18 Edwards syndrome, trisomy 21 Down syndrome, or 47,XXY Klinefelter syndrome). **Mosaicism** indicates one or more cell lines with a different karyotype, usually arising from mitotic nondisjunction (failure of two paired chromosomes to separate) or anaphase lag (omission of a chromatid due to its delayed separation in anaphase) in the postfertilization embryo. **Polyploidy**, multiples of the haploid number of chromosomes, is a significant cause of spontaneous miscarriage.

## Structural Abnormalities

Structural abnormalities can result from DNA replication errors, from meiotic errors during crossover, or from chromosomal breaks induced by radiation, drugs, or viruses. In a **translocation**, there is interchange of material between two or more nonhomologous chromosomes. A balanced translocation is associated with neither gain nor loss of genetic material, and such an individual is a translocation carrier. If the balanced translocation involves the q arms of two acrocentric chromosomes, the translocation is referred to as a Robertsonian translocation. Although carriers of balanced translocations generally have no overt phenotype themselves (as their genetic content is complete, albeit chromosomally rearranged), they are likely to have gametes with unbalanced genetic content, due to the segregation of translocated chromosomes during meiosis. This increases the likelihood of chromosomally unbalanced offspring, which most frequently manifests in pregnancy loss.

Another class of structural abnormalities is insertions, duplications, and deletions. In these abnormalities, a chromosomal segment is moved from one locus to another, duplicated in a neighboring location, or omitted entirely. Large deletions that result in the loss of several essential genes can cause severe pathology (e.g., cri-du-chat syndrome) or pregnancy loss. Smaller deletions and duplications, however, can range from being pathogenic to simply another source of genetic variation found throughout the population. Such deletions and duplications, often referred to as “del dups” or copy number variation (CNV), cover nearly 10% of the human genome.

Other structural abnormalities include chromosomal inversions and ring chromosomes, which can cause pathology by disrupting essential genes or creating an

unbalanced genetic state (i.e., with concomitant deletion or duplication of genetic material).

# Epigenetic Variation and Genomic Imprinting

Variation can also be generated at the epigenetic level. For instance, the DNA methylation pattern varies from one individual to the next, based upon both heritable and environmental factors. In some situations, this variation leads to subtle or unrecognized phenotypic effects. However, when the methylation involves certain genetic loci, it can lead to specific disorders. For instance, aberrant methylation of the H19 gene can result in the Silver-Russell syndrome or Beckwith-Wiedemann syndrome.

Genomic imprinting is a specific epigenetic process that confers persisting influence on genome function based upon the parent of origin for a given allele. For instance, in certain autosomal recessive conditions, the expression, severity, and age of onset are influenced by the gender of the parent providing the mutant gene or chromosome. Because genomic imprinting can silence the expression of an allele from one parent, this can also lead to more severe phenotypes in the setting of a concomitant deletion. This is seen in the Angelman and Prader-Willi syndromes, where a deletion of chromosome 15q11-13 leads to hemizyosity (i.e., only one copy is present) of three notable genes, SNRPN, NDN, and UBE3A. Because these three genes are imprinted, with only the paternal alleles of SNRPN and NDN expressed and the maternal allele of UBE3A expressed, the same 15q11-13 deletion leads to different nonfunctional genes if it is inherited maternally versus paternally. With different genes functionally absent in each scenario, two distinct phenotypes emerge, representing the Angelman and Prader-Willi syndromes.

# TECHNIQUES OF MOLECULAR BIOLOGY

---

An enzyme that breaks the phosphodiester bonds and cuts the DNA molecule into fragments is an endonuclease; a **restriction enzyme** (restriction endonuclease) cuts only at sites with specific nucleic acid sequences. Restriction enzymes were discovered in bacteria in which they form a defense mechanism to cut (and thus inactivate) any foreign DNA (from invading viruses) introduced into the bacterial cell. As part of this protection mechanism, bacteria also contain methylases that methylate recognition sites in native DNA, directing the action of the restriction enzyme to the nonmethylated foreign DNA. Different bacteria have different restriction enzymes with specific action sites. Restriction enzymes are available that cut DNA into pieces (restriction fragments), ranging from many small fragments to a few large pieces, depending on the number of nucleotides in the recognition sequence. The enzymes are named for the organism and strain from which they are derived. The combination of restriction fragments, the merger of two cut pieces of DNA, yields **recombinant DNA**.

**DNA polymerase** is an enzyme that brings single nucleotides into a DNA molecule. A DNA polymerase can form DNA only in the presence of a DNA template; the synthesized DNA will be complementary to the template. RNA polymerase can make RNA, also only in the presence of a DNA template.

A deoxyribonuclease (**DNAase**) can remove nucleotides. By combining DNAase treatment with DNA polymerase action, radiolabeled nucleotides can be introduced into a DNA molecule, producing a **DNA probe**. A DNA probe can be compared with the antibody used in immunoassays. The antibody is specific and recognizes the epitope against which it is formed. The DNA probe specifically detects a sequence of DNA.

**Reverse transcriptase** is DNA polymerase that is RNA dependent. It is called reverse transcriptase because the flow of information is from RNA to DNA, the reverse of the usual direction of flow. This enzyme permits the copying of essentially any RNA molecule into single-stranded DNA; such DNA is called **complementary DNA (cDNA)** because it is a mirror image of the mRNA. Complementary DNA probes are limited by their reading only the exons (remember that introns are excised from RNA via splicing).

DNA and RNA are charged molecules and, therefore, will migrate in an electrical field. Fragments can be analyzed by gel (agarose or polyacrylamide) electrophoresis, the largest fragments migrating the slowest. By convention, the gels are read from top to bottom, with the smallest fragments at the bottom.

# Southern Blot Analysis

DNA is first denatured to separate the two strands and digested by restriction enzymes to produce fragments that are loaded into an electrophoresis gel. The Southern blot method, named after its inventor E.M. Southern, separates the fragments by electrophoresis based on size; the smaller the fragment, the faster the migration. The electrophoresis gel is placed over a thick piece of filter paper with its ends dipped in a high-salt solution. A special membrane (nitrocellulose or nylon) is placed over the gel, and over this is placed a stack of paper towels compressed by a weight. The salt solution rises by wick action into the filter paper; it moves by capillary action through the gel, carrying the DNA with it. The DNA is carried to the membrane to which it binds. The salt solution keeps moving and is absorbed by the paper towels. The nitrocellulose or nylon membrane thus creates a replica of the original electrophoresis pattern. The DNA is fixed to the membrane either by high-temperature baking or by ultraviolet light. Specific labeled DNA or RNA probes then can be introduced for hybridization. **Hybridization** means that a specific probe anneals to its complementary sequence. The fragments with this sequence are then identified by autoradiography. Fluorescent probes can be utilized that can be detected after activation by a laser beam, allowing qualitative and quantitative assessment by a computer. Southern blotting is still a necessary procedure, but it is often replaced by the faster and more sensitive technique of PCR.

**Northern blotting** detects RNA sequences; it is called “Northern” because RNA is the opposite image of DNA. Extracted RNA is separated by electrophoresis and transferred to a membrane (as in Southern blotting) for hybridization with probes of complementary DNA. Northern blotting could be used, for example, to determine whether hormone stimulation of a specific protein in a tissue is mediated by an increase in mRNA, that is, gene expression. Northern blotting can also be replaced by PCR using a reverse transcriptase enzyme.

Electrophoresis to separate and quantitate proteins is called **Western blotting**, and antibodies are used for the hybridization identification process. Like Northern blotting, Western blotting tests gene expression, not just the presence of a gene. The terms **Northern and Western** represent intentional witticisms (a rare event in science) in response to Southern blotting. Hybridization without electrophoresis by placing a drop of the cell extract directly on filter paper is called **dot or slot blotting**.

# Hybridization

When two complementary strands of DNA reassociate, the process is called hybridization. Hybridization allows a specific area of the DNA to be studied using a radiolabeled DNA probe that is specific (via a complementary sequence). The membrane produced after Southern blotting is first treated to block nonspecific binding sites. The membrane is then treated (hybridized) with the labeled probe. The location of bound probe is then identified by autoradiography (for radiolabeled probes) or by colorimetric methods. The sequence of the probe, therefore, determines the sequence at the site of binding. Whenever two products are complementary, hybridization occurs. Thus, complementary DNA can be hybridized to its template mRNA.

In situ hybridization is the technique in which labeled DNA or RNA probes are placed directly on a slide of tissue or cells. A piece of cloned DNA labeled with a fluorescent marker can be utilized; the method is referred to as **FISH** (fluorescence in situ hybridization). The region corresponding to the cloned DNA lights up under fluorescent illumination unless the region has been deleted from one of the chromosomes. Several microdeletion syndromes have been discovered with the FISH technique, for example, the Prader-Willi syndrome.



# DNA Microarrays

DNA microarrays (or simply “arrays”) use the hybridization approaches described above in a multiplex format sometimes referred to as a “lab-on-a-chip.” Thousands of DNA probes are attached to the surface of a glass slide or similar material in a known arrangement. Hybridization of sample DNA causes a detectable reaction, such as chemiluminescence or fluorescence, which denotes the relative amount of hybridization that occurred (these techniques are semiquantitative, comparing the amount of hybridization to that of a reference control). Microarray technology can be used for a variety of experiments and clinical tests, such as the detection of gene expression, single-gene sequence variation, and chromosomal content. Expression arrays hybridize cDNA generated from RNA from a tissue of interest to complementary DNA probes. If the tissue of interest expresses a gene, the labeled signal is easily observed. Single-nucleotide polymorphisms (SNPs) arrays are one type of microarray used for the assessment of sequence variation. Such arrays contain probes representing the known alleles at a given nucleotide position. Homozygosity, heterozygosity, and even aneuploidy can be detected with this approach.

Chromosomal content can also be assessed using array comparative genomic hybridization (array CGH or aCGH), which measures the hybridization between a DNA sample of interest (for instance, from a trophoblast biopsy) and control DNA probes that cover the entire human genome. Aneuploidy and CNV can both be detected with this approach by comparing the sample’s hybridization to that of a known reference control. While array CGH is a powerful tool for detecting numerical and unbalanced chromosomal abnormalities, it is not currently effective for detecting balanced structural chromosomal abnormalities. Because the processing of the sample DNA involves fragmentation of its genome-level structure, balanced structural rearrangements are typically undetectable by array CGH (an analogy would be if someone dropped a stack of papers meant to constitute a book; while one could subsequently ensure that all the pages are accounted for, they could not be sure that the papers were in the proper order before the stack was dropped). Karyotype remains the most effective way to detect balanced structural abnormalities.

# Polymerase Chain Reaction

The PCR is a technique to amplify (relatively quickly) small fragments or areas of DNA into quantities large enough to be analyzed with electrophoresis and blotting methods. This technique produces enormous numbers of copies of a specific DNA sequence without resorting to cloning. The sequence to be amplified must be known. Specific markers (synthesized short sequences of DNA corresponding to each end of the sequence to be studied) are selected that will delineate the region of DNA to be amplified. These flanking sequences are called primers. The DNA sample, the primers, and an excess of free single nucleotides are incubated with a DNA polymerase.

The first step involves separating DNA into its single strands by denaturation with heat (approximately 92°C); then the temperature is lowered (approximately 60°C), causing the primers to stick (anneal) to their complementary regions on the DNA. The temperature is raised to 72°C, and DNA polymerase then synthesizes a new strand beginning and ending at the primers, forming a new double-stranded DNA. Repeating the cycle many times (by fluctuating the reaction temperature) exponentially amplifies the amount of DNA available for study, allowing DNA from small specimens (such as embryonic biopsies) to be adequate for assessment. Because the process requires alternate heating and cooling, a DNA polymerase resistant to heat is an advantage in that periodic replenishment is not necessary. This problem was solved with the discovery of a DNA polymerase (Taq polymerase) from a thermophilic microorganism (*Thermophilus aquaticus*) found in an out-of-the-way Yellowstone National Park hot spring called Mushroom Pool. This high-temperature polymerase allows automation of the process.

Reverse transcription PCR is used to amplify the sequence of small amounts of a specific RNA. The starting template is an RNA molecule, which is converted to its complementary DNA by reverse transcriptase, an enzyme originally discovered in retroviruses. The newly synthesized cDNA is then processed by the standard PCR procedure to yield larger quantities of DNA corresponding to the RNA of interest.

Real-time PCR (also known as quantitative PCR) is now routinely used in clinical laboratories. The method uses fluorescent probes to measure the amount of DNA produced in a PCR while it is occurring. This approach can be used to detect small amounts of specific DNA in rapid fashion, such as in the diagnosis of infectious disease, or combined with reverse transcription to measure the expression of a gene of interest. Unlike the conventional PCR (also called end-point PCR), real-time PCR is capable of providing a reliable quantitative comparison between samples by limiting the analysis to the stage of amplification where the reaction shows linear amplification (cDNA content doubles with each reaction).

# DNA Sequencing

DNA sequencing is the name for the set of approaches that allow the nucleotides in a particular portion of the genome to be identified in order. Sanger sequencing (also known as chain-termination sequencing) was the most common approach to sequencing for most of the past 40 years. An *in vitro* DNA replication reaction is carried out, with a DNA polymerase directing the incorporation of nucleotides beginning at a site directed by a DNA primer. The set of nucleotides for each reaction includes a subset that is modified in such a way that terminates DNA strand elongation. These modified nucleotides (called dideoxynucleotides, or ddNTPs) are typically fluorescently labeled to allow automated detection for more rapid machine-based sequencing. The base-specific fluorescent wavelength is matched to the length of the fragment (as determined by capillary electrophoresis) to determine the DNA sequence.

More recently, advances in DNA sequencing have been made to allow high throughput at decreased costs. Collectively referred to as next-generation sequencing (NGS) or massively parallel sequencing, these approaches are based upon the concept of conducting millions to billions of sequencing reactions at the same time in distinct spatial arrangements. While there are many different methods currently employed for NGS, the majority of these use sequencing by synthesis. In this approach, clonally amplified DNA is kept in distinct spatial compartments, where it acts as the template for a DNA replication reaction. The distinct spatial compartments can be achieved through methods such as emulsion PCR, which uses water-oil emulsion droplets to keep DNA molecules separated, and DNA colony formation, which uses DNA adapters and bridge amplification to produce small clusters of replicated DNA fragments at distinct locations on the surface of a flow cell. Unlike in Sanger sequencing, the NGS replication reactions use a variety of approaches that allow the base-by-base extension of the DNA molecule to be visualized as it occurs.

# Chromatin Immunoprecipitation

Chromatin immunoprecipitation (ChIP) localizes a protein to its binding site on DNA. The technique uses an antibody that is specific to the protein of interest. The DNA that is isolated by the antibody-protein-DNA complex can then be studied by PCR. The specific regions of the genome, bound by the protein of interest can be also determined by using a DNA microarray, a method known as ChIP-on-chip.

# Cloning DNA

Cloning means isolating a gene and making copies of it. A DNA library is a collection of DNA molecules derived from cloning methods. A complementary DNA library is the DNA counterpart of all of the mRNA isolated from a particular cell or tissue. By starting with mRNA, the search for the gene of interest can be focused (instead of searching the entire genome). Such a library is made using reverse transcriptase. The DNA molecules then can be inserted into an appropriate vector (described below), and replicate molecules can be produced. Using probes, the complementary DNA can be selected that matches the gene of interest (keeping in mind that complementary DNA only includes the exons of a gene). Cloning the DNA simply means the production of many identical copies of a specified fragment of DNA. Cloning can also be performed using the PCR. As indicated above, complementary DNA cloning focuses on the DNA counterpart of mRNA; genomic DNA cloning, using a restriction endonuclease, copies the DNA in genes. Cloning also can be used to make multiple copies of probes or unknown DNA fragments.

If the amino acid sequence is unknown, one can work backward. Knowing the specific protein product, antibodies can be produced against the protein. When complementary DNA is inserted into certain vectors, production of the protein can be identified with the antibodies; thus, the DNA fragment will be isolated.

A vector is an entity in which foreign DNA can be inserted. The vector plus the foreign DNA are inserted into a host cell; the host cell produces both the vector and the foreign DNA. The first vectors were bacterial plasmids, circular DNA molecules (minichromosomes) that coexist in the cytoplasm with the bacterial chromosomal DNA. Most noteworthy, they carry genes that code for antibiotic resistance. This enables the bacterial cells that contain the plasmid to be selected by appropriate antibiotic treatment. Plasmid vectors have also been developed that allow selection by color. A variety of bacterial strains have been developed, each for a specific use.

Disruption of the plasmid DNA with restriction enzymes, followed by incorporation of foreign DNA with DNA ligase, produces plasmid DNA molecules (recombinant DNA containing the foreign DNA) that can be replicated. Plasmid vectors can incorporate foreign DNA fragments up to 10 kb in size. Digestion of recovered plasmids with restriction enzymes releases the desired DNA fragment, which can then be recovered by electrophoresis.

Other vectors exist. Bacteriophages (or phages) are viruses that infect and replicate within bacteria. Phage vectors can incorporate larger DNA inserts, up to 20 kb. Cloning DNA with phage vectors follows the same basic design as with plasmids. Larger fragments of foreign DNA are cloned with cosmid vectors, artificially produced combinations of phage and plasmid vectors. Very large fragments, up to 1,000 kb, can

be cloned using yeast artificial chromosomes. This method can work with whole genes.

**Basic Steps for Cloning:**

1. Choose a DNA source: either genomic DNA or complementary DNA.
2. Fragment the DNA by restriction endonucleases.
3. Insert the fragments into vectors.
4. Introduce the vectors into bacteria.
5. Collect the cloned DNA propagated in the bacteria to form a library.
6. Screen the library for the desired sequence. Possible methods include the use of complementary nucleotide probes for fragments that hybridize or the detection of a specific protein produced with antibodies to the protein or by assaying the function of the protein.

# Transgenic Animals

Transgenic animals are produced by inserting cloned genes or complementary DNA into such organisms as bacteria, yeast, worms, or mice. In mammals, the cloned gene or cDNA can be injected into a pronucleus of a fertilized egg where it will be integrated into the chromosomes. The modified embryos are transferred to the uterus of a recipient mother who will deliver progeny with the foreign DNA. Altered biologic behaviors and functions are then attributed to the foreign DNA. Transgenic animals provide animal models for human disease and are an avenue to study the *in vivo* functional effects of genetic variation.

Animal models for the function of a gene often employ the method of “knocking out” a specific gene. Knock-outs are generally created by *in vitro* homologous recombination between a nonfunctional transgene and the native gene of interest in embryonic stem cells. In a straightforward demonstration, it can be determined whether a specific gene and its protein are essential for a specific process (such as normal folliculogenesis) or for life altogether.

Compared to constitutive gene knock-out models, which have gene knock-out in all tissues from the earliest stages of development, conditional knock-out models give greater flexibility and precision. In this type of knock-out, the functional gene is only inactivated at a specific time in development or in a specific cell type.

An alternative to homologous recombination-based transgenesis is the CRISPR/Cas9 method of gene editing. In this system, a targeted guide RNA directs the Cas9 endonuclease to create double-stranded breaks in DNA at a specific site. A repair template DNA specifies the modified DNA sequence, which is incorporated at that site by the intrinsic cellular mechanism of homology-directed repair (HDR). Alternatively, some of the double-strand breaks will be repaired by nonhomologous end joining (NHEJ), which causes random insertions or deletions that lead to gene knock-out. Methods are being developed to optimize the HDR:NHEJ ratio for the intended applications of CRISPR/Cas9.

# Genomics, Proteomics, and the Omics Revolution

With technologic and bioinformatic advances allowing high-throughput assessment of large amounts of data, molecular biology has gone through a period referred to as the “omics revolution.” While genetic research historically has focused on single genes, the complete sequencing and study of entire genomes is referred to as genomics. Beyond just the compilation of massive amounts of sequence data, genomics research allows for a system-level study of gene interactions and expression. The study of genetic variation among members of a species is often called “variomics”; such extensive cataloging of human variation is ongoing, building upon the progress of such publicized efforts as the HapMap Project and the 1000 Genomes Project. Characterization of the range of epigenetic variation in a species is referred to as “epigenomics.”

Genomics and its relatives, however, will not tell the whole story. The protein products of gene expression are altered in the translation process and also by posttranslational modifications such as glycosylation, methylation, and phosphorylation. Thus, a more complete picture can emerge with proteomics, the study of the biologically functional end products, the proteins of a cell or a tissue. Both genomics and proteomics are keys to understanding physiology and diagnosing diseases, and for the design of new drugs.

**Metabolomics** is the study of small molecules within cells, the metabolic products that characterize cells. Crude cellular extracts are subjected to chromatography, spectrometry, or nuclear magnetic resonance measurements to create characteristic chemical fingerprints associated with normal or abnormal cellular function.

The amount of data generated in omics research is enormous, impossible to manage without computer databases. Bioinformatics is the science dedicated to the development of computer algorithms to best organize and analyze this growing wealth of information, and for creating efficient search and retrieval systems. This allows the data to be available to laboratories scattered throughout the world and the study of the information with sophisticated mathematical analysis.



# THE IDENTIFICATION OF GENES

---

To clone an entire gene whose protein product is known, a complementary DNA library is produced. The specific DNA fragment is identified by linking it to the protein. Once identified, the total gene can be screened using the identified complementary DNA, indicating the introns and exons. Another strategy is to synthesize an oligonucleotide probe, basing the sequence on the known amino acid sequence in the protein product (from the peptide sequence, the DNA sequence that codes for that protein can be predicted). This method can be used with just a relatively small piece of the peptide. Complementary DNA can be cloned without producing a library by using the PCR to amplify complementary DNA made from mRNA by reverse transcriptase. Overlapping sequences of the genome can be cloned, using a piece of DNA from each succeeding product, to work across a chromosome in a systematic manner to search for a gene; this is called **chromosome walking**.

The entire sequencing process can be performed by a computer, even searching for open reading frames. Once the sequence of a DNA fragment has been identified, the computer can utilize DNA and protein databases to predict sequence, recognition site, protein translation, and homology with known sequences. The scientist can then select restriction fragment sizes for cloning. Once a gene has been analyzed, it has to be compared with the gene in the disease state. If a variant is of large size, this can be detected by Southern blotting. Minor alterations require comparisons in DNA sequences, which is possible by using polymerase chain amplification to produce specific gene sequences in amounts readily studied.

A gene can be localized to a specific chromosome when its protein product is unknown by studies involving chromosome rearrangements and linkage analysis. Specific diseases are associated with karyotypic changes. Thus, the specific chromosome can be targeted for gene localization. Linkage analysis utilizes restriction fragment length polymorphisms.

# DNA Polymorphism

Southern blotting reveals specific patterns of bands that reflect the varying lengths of the DNA fragments produced by restriction enzyme action. A specific site can exhibit a mutation by having a different pattern (a different length of the DNA fragment on Southern blotting due to sequence difference). These differences in DNA sequences are called **restriction fragment length polymorphisms**. Single-nucleotide polymorphisms, referred to as SNPs, or simply polymorphisms, are usually benign and common variations. The human genome contains about 4.5 million polymorphisms, and more than 3 million have been identified. Although 99.9% of DNA sequences in humans are the same, SNPs can serve as genetic markers for a medically important gene. A polymorphism is governed by the mendelian regulations of inheritance, and if by chance a polymorphism is identified in a patient with a specific disease, the transmission of the disease can be studied. The polymorphism, which is linked to the disease by chance, can be used to study the inheritance of a disease when the genes are unknown. The polymorphism is like a flag that marks specific areas of chromosomes. This method of study requires DNA from at least one affected individual and a sufficient number of family members to trace the polymorphism, either by Southern blotting (for long sequences) or with the PCR (best for short sequences). Correlation of genetic markers (polymorphisms) and phenotype also employs **haplotypes** (similar to a polymorphism but a longer sequence of nucleotides, even a set of several polymorphisms). Efforts using genetic technologies to link SNPs and haplotypes to clinical problems and inherited traits are known as **genome-wide association studies**.

Minisatellites are a form of polymorphisms. Genes concentrate in random areas along chromosomes separated by long sequences of noncoding DNA. Minisatellites are noncoding areas of DNA that repeat in variable numbers, so-called variable number **tandem repeat sequences**, distributed throughout the length of every human chromosome. These areas can be followed by DNA probes, providing a “fingerprint” for specific individuals. This uniqueness is applied in forensic medicine. Microsatellites, as the name implies, are smaller than minisatellites. Usually, microsatellites consist of repetitions of only two nucleotides. DNA polymorphisms now number in the thousands and allow genetic mapping with great precision.

# The Human Genome Project

All of the human genes are collectively known as the genome. Begun in 1990, the goal of the international Human Genome Project was to sequence the human genome, a goal that was reached in draft form in 2001 and 99% of the actual sequence in 2003, more than 2 years ahead of schedule, 50 years after Watson and Crick's publication. The number of protein-encoding genes (20,000–25,000) is smaller than previous estimates. Less than 2% of the human genome with nearly 3 billion nucleotides codes for proteins; therefore, the remainder is a rich resource for evolutionary historians and a target for inducing genetic changes. The number of genes in specific chromosomes varies; the chromosomes that are affected by trisomy, chromosomes 13, 18, and 21, have the fewest genes. (Information on the human genome project is available at [http://www.ornl.gov/sci/techresources/Human\\_Genome/home.shtml](http://www.ornl.gov/sci/techresources/Human_Genome/home.shtml))

Fortunately, the Internet emerged in time to accommodate the enormous data generated by studying the human genome. The National Center for Biotechnology Information (NCBI) maintains a Web site that provides databases as well as the Online Mendelian Inheritance in Man (OMIM) site developed by Victor A. McKusick at the Johns Hopkins University as a guide to human genes and inherited disorders (<https://www.ncbi.nlm.nih.gov/omim>).

The next wave of information will come from projects like the ENCODE project and the 1000 Genomes project. ENCODE is a research consortium organized by the National Human Genome Research Institute of NIH to develop an encyclopedia of the functional elements in the human genome (<http://www.genome.gov/ENCODE>). The 1000 Genomes project provides the genome sequence of 1,000 people from around the world to map DNA variations with a fine resolution (<http://www.internationalgenome.org/data/>).

The human genome map can serve as a foundation for locating sites for heritable factors that predispose for diseases and mutations that cause disease and for integrating the genetic sequencing with biologic functions. Soon, we will be able to have in our possession a personal record of our individual complete genetic blueprint.

The chromosomal locations of genes responsible for hormone production have been mapped. From the cloned DNA sequences, the amino acid sequences can be predicted. Every protein product of a gene represents a potential diagnostic or therapeutic target. And of course, inherited disorders will be subject to characterization and, eventually, gene therapy. However, even after a gene has been identified and genetically mapped, its full characterization remains a difficult and time-consuming task. Full understanding of disorders that involve the interactions of multiple genes will be even more complicated.

# CLINICAL APPLICATIONS

---

The challenge for modern medicine is to make clinical sense of the massive collection of data generated by genomics and proteomics. Understanding the function of genes and proteins will undoubtedly be an accelerating feature of human progress. Knowing an individual's genetic susceptibilities would allow medical diagnosis and treatment to be personalized to a higher degree. Nevertheless, this is a complicated new era and not always straightforward. For example, a genetic susceptibility may carry with it only a small percentage increase in risk for a disease; at what point is intervention merited in terms of benefit and cost, not only for an individual but for society? In addition, gene activity can be turned on and off in response to environmental factors. From the bench to the bedside may be slower than anticipated, but there is no doubt that we are on the verge of translating genomic theory into clinical practice.

# Diagnosing Genetic Disorders

The molecular diagnosis of genetic disorders requires only a small sample of DNA, obtainable from any cells that are nucleated, such as white blood cells or epithelial cells. PCR amplifies the small sample of DNA, allowing a variety of assays to be performed to identify clinically relevant genetic variants. These diagnostic assays can employ a variety of techniques; many utilize the DNA sequencing or hybridization approaches outlined earlier in this chapter. Sequencing approaches can be based upon either Sanger sequencing or NGS, and can even entail whole exome sequencing (WES) if the locus of genetic variation is not clinically apparent. Hybridization approaches can be as simple as single DNA probes that hybridize to allele-specific DNA sequences during real-time PCR or as complex as custom-designed microarrays with probes for a variety of genetic variants related to a certain condition.

Molecular diagnosis is limited by the prevalence of genetic heterogeneity. In other words, many disorders result from different mutations in different people. In contrast, some (like sickle cell disease) always involve the same change. With cystic fibrosis, 70% of patients (of northern European ancestry) have the same 3-base deletion, whereas the remaining 30% have an extremely heterogeneous collection of mutations. The benefit to using a sequencing-based approach for molecular diagnosis is that it can provide a more comprehensive view that does not ignore such novel or rare variants. The inherent downside to this approach, however, is that it can identify variants of unknown significance (VUS), which may be simply benign variants. Understanding the significance of detected rare or novel variants requires close evaluation of their likelihood of pathogenesis, such as by examination of cross-species conservation or segregation of the mutation with an identified disease in a family.

# Preimplantation Genetic Testing

One of the most important clinical applications of genetic techniques in modern reproductive medicine is preimplantation genetic testing. Such testing includes the assessment of embryos for known mutations (classically known as preimplantation genetic diagnosis, or PGD, now called preimplantation genetic testing for monogenic disorders, PGT-M) as well as for aneuploidy, whether due to the parental karyotype or due to age-related factors (classically known as preimplantation genetic screening, or PGS, now called preimplantation genetic testing for aneuploidy, PGT-A). In each of these applications, the in vitro fertilized embryo is biopsied, with some of its cells serving as the source of the DNA template for the assay. This biopsy can be done at several developmental stages, sampling the polar biopsy of the fertilized oocyte, blastomeres at the cleavage stage, or trophectoderm cells in the blastocyst. While polar body biopsy offers the advantage of leaving the embryo undisturbed during sampling, it is only capable of sampling the maternal genetic contribution, and thus is of more limited utility. Cleavage-stage biopsy was the preferred method of biopsy for a number of years but has fallen out of favor due to higher rates of chromosomal mosaicism and concern for detriment to subsequent development of the biopsied embryo. Blastocyst biopsy has become the favored method for many IVF centers, due to the larger DNA yield and improved diagnostic accuracy of this approach.

When the intent of the preimplantation genetic testing is for identification of a known mutation (for instance, in the embryonic offspring of a couple who both carry a harmful recessive mutation), the extracted DNA from the biopsied cells is amplified and genotyped. Genotyping can be done through a variety of sequencing- and hybridization-based approaches, much like genotyping in an affected adult. To reduce the chance of diagnostic error, a selection of informative linked polymorphisms are often genotyped concurrently with the mutation of interest. Consistency of genotype data for all linked polymorphisms strengthens the confidence that the mutation of concern has been accurately diagnosed.

In the case of aneuploidy assessment, the extracted DNA from the biopsy specimen can be assessed using one of many different techniques. Historically, FISH was the preferred method for detection of aneuploidy in embryonic biopsies. Using a limited number of hybridization probes, a subset of chromosomes can be analyzed for numerical abnormalities. Recognition of the incomplete assessment that this provides, along with the availability of high-throughput technologies that allow comprehensive assessment of the chromosomes, has shifted attention away from FISH. Modern approaches to preimplantation genetic testing for aneuploidy include array CGH, SNP arrays, and NGS. While some have expressed continued concern about the diagnostic accuracy of even these more advanced approaches (citing examples of false positives), many view

this approach for embryonic selection as an avenue to reduced time to live birth and increased per-transfer live birth rate, at least in selected populations.

# Personal Genomics

One exciting avenue of ongoing investigation is precision medicine and personal genomics. With decreasing costs for DNA sequencing and genotyping, it is easy to envision a near-future where many people will have their genome sequenced. As we approach that time, the identification of genetic risk factors for a range of disorders has led to the establishment of genetic risk panels for many disease processes, from breast cancer to infertility. The clinical utility of such panels will hinge upon continued research into the absolute risk that they confer, especially when combined with relevant environmental factors. Such knowledge will allow a greater utility for personal genomes when they truly become a common clinical information source.

Related to the concept of personal genomics is pharmacogenomics, the study of genetic variations in pharmacodynamics that can explain different responses to the same dose of a drug. For example, different polymorphisms involved in enzyme synthesis can affect metabolism and clearance. Genetic testing offers the potential to predict drug pharmacokinetics in an individual, which would allow the selection of an appropriate dose to minimize side effects and maximize efficacy.



# A FINAL THOUGHT

---

Molecular progress is inexorable. The future will see preventive medicine by prediction. By knowing an individual's genetic constitution, appropriate and intensive screening can be directed to predisposed conditions. This kind of knowledge will also require social and political considerations. It is not far-fetched to envision lifestyle decisions made based on the information regarding genetic predispositions. Society is developing guidelines regarding the use of this information: by individuals, by employers, by health organizations, and by the government. Scientific progress must be matched by public and professional education to appropriately manage this knowledge.

# KEY READINGS

1. **Collins FS, Green ED, Guttmacher AE, Guyer MS; on behalf of the U.S. National Human Genome Research Institute**, A vision for the future of genomics research. A blueprint for the genomic era, *Nature* 422:835, 2003.
2. **Croce CM**, Oncogenes and cancer, *N Engl J Med* 358:502, 2008.
3. **Espy MG**, Real-time PCR in clinical microbiology: applications for routine laboratory testing, *Clin Microbiol Rev* 19:165, 2006.
4. **Hardy B-J, Séguin B, Goodsaid F, Jimenez-Sanchez G, Singer PA, Daar A**, The next steps for genomic medicine: challenges and opportunities for the developing world, *Nat Rev Genet (Suppl 1)*:S23, 2008.
5. **International HapMap Consortium**, A haplotype map of the human genome, *Nature* 437:1299, 2005.
6. **International Human Genome Sequencing Consortium**, Finishing the euchromatic sequence of the human genome, *Nature* 431:931, 2004.
7. **Pearson TA, Manolio TA**, How to interpret a genome-wide association study, *JAMA* 299:1335, 2008.

# Endometriosis

Dr. Karl von Rokitansky was one of the first to describe endometriosis in 1860.<sup>1</sup> While he is credited with the microscopic discovery of the disease, reports dating back to 1690 by the German physician Daniel Shroen describe the characteristic peritoneal appearance of endometriosis. To an extent, he accurately described their location, content, and cause of pain: “ulcers distributed throughout the [peritoneum]... located predominantly in the bladder, intestines, broad ligament, and outside the uterus and cervix... [these sores are] inflammations that had a tendency to form adhesions that linked visceral areas together”.<sup>1</sup> A similar description was made by many other physicians of the 17th, 18th, and 19th centuries, with the additional discovery of the link to monthly menstruation and the presence of ovarian cysts with “blackish vesicles.”<sup>2</sup> However, it was not until the 20th century that Dr. John Sampson—now known as the “father of endometriosis”—described a series of perforating hemorrhagic ovarian cysts he called “chocolate cysts,” coining the term “endometriosis” to describe the peritoneal implants he first envisioned as seedlings derived from disease in the ovary.<sup>3</sup> In addition to naming the gynecologic disorder (endometriosis), he also proposed the theory of retrograde menstruation as the pathogenesis of this disorder.<sup>2</sup> His 1927 publication was one of the most influential and remains the prevailing teaching regarding the theory of endometriosis. Despite its recognition for centuries, the pathogenesis of endometriosis is still poorly understood, but investigations employing modern molecular methods are yielding new insights into the mechanisms of the disease and suggesting new approaches to its diagnosis and treatment.

# DEFINITION OF ENDOMETRIOSIS

---

Endometriosis is a chronic gynecologic disease characterized by endometrial-like tissue outside of the uterus and is associated with pelvic pain and infertility. The ectopic endometrial tissue usually is located in the pelvis but can appear anywhere in the body—the most common sites are the ovaries, anteroposterior cul-de-sac, uterosacral and broad ligaments, fallopian tubes, sigmoid colon, and the appendix.<sup>4</sup> The three main types of endometriosis are peritoneal, deep infiltrating, and ovarian.<sup>5</sup> As an estrogen-dependent disorder, ectopic lesions undergo cycles of growth and bleeding in synchrony with the menstrual cycle. The disease exhibits a broad spectrum of clinical signs and symptoms and is prone to progression and recurrence. Furthermore, it has adverse effects on quality of life and significant economic burden.<sup>6,7</sup>

# EPIDEMIOLOGY OF ENDOMETRIOSIS

---

As there is currently no noninvasive, reliable method for diagnosing endometriosis, the true prevalence of endometriosis is not known. Currently, surgery is considered the definitive method for diagnosis, yet is generally not performed on women without symptoms or physical findings that strongly suggest the disease; accordingly, estimates vary with the indication for surgical treatment. The prevalence of asymptomatic endometriosis is 1–7% in women seeking elective sterilization, up to 60% among women of reproductive age with pelvic pain, and 50–60% of women and adolescents with pelvic pain and/or unexplained infertility.<sup>8,9,10,11,12,13,14</sup> The overall prevalence of endometriosis in reproductive-aged women is approximately 10%.<sup>14,15,16,17,18</sup>

The mean age at time of diagnosis of endometriosis ranges between 25 and 35 years.<sup>19,20</sup> Endometriosis is rare in premenarchal girls but may be identified in 50–70% of adolescents and young women under age 20 with complaints of chronic pelvic pain or dyspareunia.<sup>10,11,21,22</sup> Most cases in young women under age 17 are associated with müllerian anomalies that include cervical or vaginal obstruction.<sup>14,23</sup> Fewer than 5% of women who require surgery for endometriosis are postmenopausal, and most have received estrogen therapy.<sup>24,25,26</sup> The prevalence of asymptomatic endometriosis may be somewhat lower in Blacks and higher in Asians than in White women, although the biologic basis for these differences is not clear.<sup>13,27</sup> Interestingly, the prevalence of endometriosis is inversely related to body mass index.<sup>20,27,28,29,30,31</sup>

Early menarche, short menstrual cycle length, and obstruction of menstrual flow have been associated with increased risk for endometriosis.<sup>14,15,27,32</sup> The correlation between the risk of disease and the volume or duration of menses is less consistent.<sup>15,32,33,34</sup> Pregnancy has a protective effect that decreases with time (the risk of endometriosis increases with the number of years since last childbirth).<sup>35,36</sup> Multiple full-term births and prolonged periods of lactation decrease the risk of endometriosis.<sup>35,36</sup> Assorted epidemiologic studies have suggested that heavy consumption of alcohol and caffeine also may increase risk and that regular exercise and smoking may decrease risk for endometriosis.<sup>15,27,32,37</sup> Primate data have suggested that exposure to the environmental toxins polychlorinated biphenyl (PCB) or dioxin may be linked with endometriosis, but studies in women have yielded inconsistent results.<sup>38,39</sup> Other data suggest that exposures in utero can play a role in development of the disease; the incidence of endometriosis is increased in women having prenatal exposure to diethylstilbestrol.<sup>40</sup> Women with endometriosis also appear to be at increased risk of ovarian cancer.<sup>41</sup> The association is modest, and specific to endometrioid and clear cell types of ovarian cancer.<sup>41</sup> While a relationship exists, the

effect sizes are small, and further research is needed to determine whether or not a direct cause and effect relationship exists.<sup>42</sup>

# PATHOGENESIS OF ENDOMETRIOSIS

---

There is no generally accepted thesis regarding the origin of endometriosis; however, Sampson's theory of retrograde menstruation is the most well-accepted theory.

**The retrograde menstruation and implantation theory holds that endometrial tissue shed during menstruation is transported via the fallopian tubes into the peritoneal cavity where it implants on the surfaces of pelvic organs.** Sampson's classic paper proposing that endometriosis is "due to menstrual dissemination of endometrial tissue into the peritoneal cavity" was published in 1927.<sup>43</sup> Several lines of evidence support the implantation theory as one of the primary mechanisms involved in the pathogenesis of endometriosis.

- Endometriosis is more prevalent in women with obstructing müllerian anomalies than in women with malformations that do not obstruct menstrual outflow.<sup>44</sup> In 80% of women with congenital cervical stenosis and functional endometrium, endometriosis develops.<sup>45</sup>
- Viable endometrial cells recovered from the peritoneal fluid during menses can be grown in cell culture<sup>46,47</sup> and can attach to and penetrate the mesothelial surface of the peritoneum.<sup>48,49</sup>
- The incidence of endometriosis is increased in women with an early menarche and/or short menstrual cycles.<sup>15,27,33,50</sup>
- Endometriosis is observed most commonly in the dependent portions of the pelvis, on the ovaries, in the anterior and posterior cul-de-sacs, and on the uterosacral ligaments, the posterior uterus, and the posterior surface of the broad ligaments.<sup>51,52,53</sup>
- Experimental endometriosis can be induced in mice and nonhuman primates after surgically induced peritoneal menstruation<sup>54,55,56,57</sup> or retroperitoneal injection of menstrual endometrium<sup>58</sup> and in women who receive peritoneal injections of their menstrual tissue.<sup>59</sup>

As the incidence of retrograde menstruation is similar in women with and without endometriosis, several other mechanisms have been proposed: coelomic metaplasia, vascular dissemination, direct transplantation, and altered immunity. More recently, stem cells and genetic origins of the disease are being investigated. No one mechanism explains all cases of endometriosis and each probably contributes, at least to some extent.

The coelomic metaplasia theory, proposed by Fergusson and colleagues in the 1960s,<sup>60</sup> offers an alternative explanation for the same observations. **The coelomic**

**metaplasia theory holds that endometriosis results from spontaneous metaplastic change in mesothelial cells derived from the coelomic epithelium (located in the peritoneum and the pleura). The induction theory is a variation on the same theme and envisions that coelomic metaplasia is induced by exposure to menstrual effluent or other stimuli.** In his original paper, Sampson himself allowed that foci of peritoneal endometriosis also might be “due to some specific irritant present in the cyst contents which stimulates the peritoneal endothelium to a metaplasia with the development of endometrial tissue typical both in structure and function.”<sup>3</sup> A number of observations suggest that endometriosis results from spontaneous or induced coelomic metaplasia, at least in some cases.<sup>61</sup>

- Endometriosis has been described in a premenarchal girl<sup>62</sup> and in women who never have menstruated<sup>63,64</sup> and also occurs in adolescent girls having had relatively few menstrual cycles.<sup>65</sup>
- Because intact endometrial cells have no access to the thorax in the absence of an anatomical defect, the retrograde menstruation/implantation theory cannot explain cases of pleural and pulmonary endometriosis (almost all of which occur on the right side).<sup>66</sup> Metaplasia in the pleura (derived from the coelomic epithelium, like the peritoneum and the müllerian ducts), induced by steroid hormones or chemical stimuli released by degenerating endometrial cells into the peritoneal fluid (which communicates with the thoracic cavity via the right hemidiaphragm), is the more plausible explanation.
- Metaplasia in misintegrated coelomic epithelium (adjacent to the mesenchymal limb buds during early embryogenesis)<sup>67,68</sup> can explain endometriosis in unusual peripheral sites like the extremities (thumb, thigh, knee).<sup>69,70,71</sup>
- Rare cases of endometriosis have been observed in men treated with high doses of estrogen (urinary bladder, abdominal wall).<sup>72,73,74</sup>
- Ovarian surface epithelium and stromal cells, cocultured with estradiol in a three-dimensional collagen gel lattice, form endometrial glands and stroma.<sup>75</sup>
- Eutopic (inside the uterus) and ectopic (outside the uterus) endometria are distinctly different, both morphologically and functionally, which is difficult to reconcile with the notion that endometriotic implants represent autotransplants of normal endometrial tissue.<sup>76</sup>

Although coelomic metaplasia might explain endometriosis in the pelvis, the thoracic cavity,<sup>66</sup> the urinary and digestive tracts,<sup>77,78</sup> the inguinal canal,<sup>79</sup> and the umbilicus,<sup>80</sup> other mechanisms are also invoked to explain cases of extrapelvic endometriosis.<sup>81,82</sup> Evidence indicates that **vascular or lymphatic dissemination of endometrial cells** also



may be involved; menstrual tissue may travel from the endometrial cavity to distant sites through lymphatic channels and veins.<sup>83,84,85,86</sup> Inadvertent **direct transplantation of endometrial tissue** at the time of cesarean section, other pelvic surgery, or episiotomy repair seems the most plausible explanation for endometriosis found in abdominal scars<sup>87,88</sup> and in the perineum.<sup>89</sup>

Alternatively, circulating stem cells originating from the bone marrow might differentiate into endometriotic tissue in various locations.<sup>90</sup> This may explain how ectopic endometrium can occur in locations outside of the pelvis, such as the lung and central nervous system. Initially, it was presumed that de novo development of endometrial tissue occurred from endogenous progenitor stem cells in the endometrium.<sup>91,92</sup> However, more recent clinical and experimental evidence have demonstrated that bone marrow–derived stem cells (BMDSCs) migrate to eutopic and ectopic endometria and differentiate into endometrial cells.<sup>92,93,94,95</sup> In a study of female allogenic bone marrow transplant recipients from a single-antigen mismatched related donor (allowing cells to be identified by HLA type), donor-derived endometrial cells were found in the endometrial biopsies of recipients.<sup>93</sup> In a murine model of transplanted male donor–derived bone marrow cells (identified by the Y chromosome) into female bone marrow, the male-derived cells were found in the endometrium, having differentiated into epidermal and stromal cells.<sup>92</sup> Furthermore, this study demonstrated engraftment of BMDSCs in the ectopic endometrial implants of previously hysterectomized mice, indicating that the endometrial tissue is capable of attracting BMDSCs despite its ectopic location.<sup>92</sup> Insights into the mechanism by which eutopic and ectopic endometrial tissues attract BMDSCs have emerged, with the CXCR4/CXCL12-axis playing a key role. CXCL12, also known as stromal cell–derived factor 1 (SDF1), is a chemokine involved in regulating cell migration.<sup>96</sup> Increased expression of CXCL12 in endometriotic implants attracts stem cells preferentially to endometriotic lesions, preventing their normal migration to the endometrium.<sup>96,97</sup> CXCR4, a chemokine receptor, and its ligand CXCL12 not only are important in stem cell recruitment but can also induce angiogenesis and tissue growth.<sup>96</sup> CXCR7, another receptor for CXCL12, is increased in inflammation and tumor growth.<sup>97</sup> Recently, CXCR7 was found to have increased expression in endometriotic lesions, where it enhances BMDSC recruitment to lesions and perpetuates their growth.<sup>97</sup> Lastly, estrogens enhance recruitment of BMDSCs, through increasing CXCL12; as endometriotic lesions have an increased local estrogenic environment, this provides yet another mechanism by which lesions can further ensure their growth and survival.<sup>98</sup>

Regardless whether pelvic endometriosis results from implantation of viable

endometrial tissue regurgitated into the peritoneal cavity at time of menses or from coelomic metaplasia induced by hormones or from stem cells, several key questions remain. Why does endometriosis develop only in some women when retrograde menstruation occurs in most women? What explains the widely varying presentations of the disease? Why is there such a poor correlation between the extent of disease and the severity of associated symptoms? Studies of the immune function and genetics of women with endometriosis are suggesting answers.

# Immunobiology of Endometriosis

Endometriosis has been associated with headaches, arthralgias and myalgias, allergies, eczema, hypothyroidism, fibromyalgia, chronic fatigue syndrome, and susceptibility to vaginal candidiasis.<sup>99</sup> Although nonspecific, given their presence in patients with known autoimmune disease, a possible link between endometriosis and autoimmune disease has been suggested.<sup>99</sup> A cross-sectional survey of members of the Endometriosis Association found that members with endometriosis had a higher prevalence of hypothyroidism, chronic fatigue syndrome, rheumatoid arthritis, systemic lupus erythematosus, Sjogren syndrome, and multiple sclerosis, compared with the published rates in the general US female population; allergies and asthma also were more common.<sup>100</sup> Although provocative, the results of the study were highly susceptible to recall and ascertainment bias. Others have found no association between endometriosis and autoimmune disease.<sup>32,101</sup>

A higher prevalence of antinuclear antibodies has been reported for women with endometriosis.<sup>102,103</sup> The most common autoantibodies identified have been directed against endometrial antigens,<sup>104,105,106,107,108,109</sup> including transferrin and laminin-1, which also is found in embryonic tissues.<sup>104,110</sup> Such immunologic autoreactivity probably results from inflammation and develops as a consequence of chronic local tissue destruction.<sup>99</sup> As endometriosis is associated with an inflammatory response/environment (as discussed below), it is perhaps not surprising that women with endometriosis can exhibit a hypersensitivity to inflammation at sites distant from pelvic implants.<sup>111</sup>

**Endometriosis is associated with changes in both cellular and humoral immunities, suggesting that impaired immune function may contribute to the development of the disease.** Altered immune function may predispose some women to develop endometriosis or influence the severity of disease in affected women. Although the peritoneal fluid of women with endometriosis contains increased numbers of immune cells, evidence suggests that their actions do more to promote the disease than to prevent it. This may explain why some women with retrograde menstruation develop endometriosis, whereas others do not. Following deposition of endometrial tissue into the peritoneal cavity, the ectopic endometrium must bypass immune defenses, attach to a surface, and ultimately invade and establish a blood supply in order to grow. Numerous immune-mediated mechanisms have been implicated.

Macrophages are a key element of the innate immune response, the part of the immune system that is not antigen specific and does not involve immunologic memory. Macrophages defend the host by recognition, phagocytosis, and destruction of offending microorganisms and also serve as scavengers, helping to clear apoptotic cells and

cellular debris. Macrophages secrete a variety of cytokines, growth factors, enzymes, and prostaglandins that help to mediate their own functions while stimulating the growth and proliferation of other cell types. Macrophages are a normal inhabitant of the peritoneal fluid, and their numbers and activity are much increased in the ectopic implants and peritoneal fluid of women with endometriosis.<sup>112,113,114,115</sup> **Instead of acting as scavengers to eliminate ectopic endometrial cells, activated macrophages and circulating monocytes in women with endometriosis appear to promote the disease by secreting growth factors and cytokines (interleukin [IL]-1, IL-6, and IL-8, tumor necrosis factor [TNF], RANTES, vascular endothelial growth factor [VEGF]) that stimulate proliferation of ectopic endometrium and inhibit their scavenger functions.**<sup>116,117,118</sup>

Natural killer (NK) cells are another important component of the innate immune system and function in two ways. NK cells have receptors for immunoglobulin G (IgG) and kill IgG-bound cells in a process known as antibody-dependent cellular cytotoxicity. NK cells also have killer-activating and killer-inhibiting receptors that, when occupied, direct or inhibit cytotoxic activity. Whereas studies of the numbers of peritoneal NK cells in women with endometriosis have yielded conflicting results,<sup>115,119,120</sup> those investigating NK cell function have consistently observed decreased cytotoxic activity, which is most pronounced in women with advanced stages of the disease.<sup>120,121,122</sup> One of the mechanisms responsible involves overexpression of killer-inhibiting receptors in both peripheral and peritoneal cells in women with endometriosis and overexpression of HLA class I molecules on ectopic endometrial cells, reducing NK cell cytotoxicity.<sup>118,123,124</sup>

Lymphocytes mediate the acquired immune response. B lymphocytes mature in the bone marrow and secrete immunoglobulins, which are antigen-specific antibodies directed against extracellular microorganisms. T lymphocytes help B cells to make antibodies and also eliminate intracellular pathogens by activating macrophages and by killing virus-infected or malignant cells. T cells are of two types, cytotoxic/suppressor T cells (involved in the cellular immune response) and helper T cells (involved in the humoral immune response). The numbers of both T-cell types are increased in the peritoneal fluid of women with endometriosis and in the stroma of ectopic endometrium.<sup>115,125,126</sup> Despite their increased number, the cytotoxicity of these cells is reduced, due to induced apoptosis via the Fas-FasL pathway by the ectopic endometrium.<sup>118</sup>

Cytokines and growth factors are a large family of soluble proteins and glycoproteins secreted by leukocytes and other cells into the extracellular environment where they act on the same (autocrine) or nearby cells (paracrine), serving as messengers both within and outside the immune system in regulation of chemotaxis,

mitosis, angiogenesis, and differentiation. As mentioned above, while an impaired cellular immune response may result in ineffective clearance of refluxed endometrial cells from the peritoneal cavity, cytokines and growth factors appear to promote implantation and growth of ectopic endometrium by facilitating its attachment to the peritoneal surface and by stimulating proliferation and angiogenesis.

IL-1 is a cytokine involved in inflammatory and immune responses and is secreted by activated monocytes and macrophages, T and B lymphocytes, and NK cells. IL-1 has been identified in the peritoneal fluid of women with endometriosis and IL-1 receptor expression is increased in endometriosis-derived stromal cells.<sup>120,121,127,128</sup> IL-1 may promote the development of endometriosis by stimulating the release of angiogenic factors (VEGF, IL-6, IL-8)<sup>129,130</sup> and by helping endometrial cells that enter the peritoneal cavity to escape immunosurveillance by inducing the release of a soluble form of intercellular adhesion molecule-1 (ICAM-1) from endometriotic cells that compete for immune recognition sites on NK and other immune cells.<sup>131,132</sup>

IL-8 is a potent angiogenic cytokine produced by mesothelial cells, macrophages, and endometrial and other cells. Peritoneal fluid levels of IL-8 are elevated in women with endometriosis and correlate with the severity of disease.<sup>133</sup> IL-8 is expressed in endometriotic implants and is up-regulated by IL-1.<sup>130,134</sup> IL-8 stimulates adhesion of endometrial stromal cells to extracellular matrix proteins, matrix metalloproteinase activity, and endometrial stromal cell proliferation in a dose-dependent manner, all of which may help to promote the implantation and growth of ectopic endometrium.<sup>135,136,137</sup>

Monocyte chemoattractant protein-1 and RANTES (regulated on activation, normal T cell expressed and secreted) are two chemoattractant cytokines that recruit macrophages into the peritoneal cavity. Both are secreted by a variety of leukocytes and by mesothelial and endometrial cells, and production of both is increased in ectopic endometrium.<sup>138,139,140</sup> In women with endometriosis, peritoneal fluid concentrations are increased and can correlate with the severity of disease.<sup>141,142</sup> IL-1 up-regulates monocyte chemoattractant protein-1 expression in ectopic endometrial epithelial cells in women with endometriosis and in cultured ectopic endometrial cells,<sup>143,144</sup> an action further stimulated by estrogen.<sup>145</sup> RANTES production by endometriotic implants is stimulated by other peritoneal fluid cytokines.<sup>127</sup>

TNF- $\alpha$  is a cytokine produced by activated lymphocytes, macrophages, and NK cells, among others. TNF- $\alpha$  is expressed in ectopic endometrial epithelial cells and is up-regulated by IL-1. IL-1 and TNF- $\alpha$  can also initiate an inflammatory response, and TNF- $\alpha$  peritoneal fluid concentrations are increased in women with endometriosis. The observations that TNF- $\alpha$  increases adherence of cultured stromal cells to mesothelial

cells suggests it may facilitate attachment of ectopic endometrium to the peritoneum in women with endometriosis; however, caution is warranted prior to making definitive conclusions as a separate research group noted the opposite effect.<sup>146,147</sup>

To implant and grow, ectopic endometrium must establish a blood supply. VEGF is an important mediator of local angiogenesis produced by monocytes and macrophages.<sup>148</sup> The growth factor stimulates proliferation of vascular endothelial cells and also acts as a chemoattractant for monocytes; it plays an important role in vascularization of endometriotic lesions.<sup>148,149</sup> VEGF is produced primarily in endometrial glands and is up-regulated by a variety of factors including estrogen and IL-1.<sup>148</sup> Peritoneal fluid VEGF concentrations are increased in women with endometriosis and are usually highest in advanced stages of the disease.<sup>150,151</sup> VEGF also is expressed in endometriotic lesions, more so in active red lesions than in inactive “powder-burn” implants.<sup>152</sup>

## Key Points: The Immunobiology of Endometriosis

- A wide variety of immunologic abnormalities have been described in women with endometriosis. The peritoneal fluid of affected women contains increased numbers of immune cells, but instead of acting to efficiently remove refluxed endometrial debris from the peritoneal cavity, they promote the disease via two basic mechanisms. Defects in cellular immune mechanisms (mediated by macrophages and NK cells) impair normal recognition and clearance of refluxed endometrial debris via the immune/inflammatory response, thereby affording endometrial cells and tissue fragments the opportunity to attach to peritoneal mesothelial cells and to invade into the extracellular matrix where they can persist and proliferate. Immune cells in the peritoneal fluid of women with endometriosis also secrete a wide variety of humoral factors (cytokines and growth factors) that stimulate attachment and proliferation of ectopic endometrium and local angiogenesis. Altered immune function may thus predispose to the development of endometriosis or to more severe disease. While it is clear that immunologic abnormalities are a consequence of endometriosis, they certainly also play an important role in its pathogenesis.

# Genetics of Endometriosis

In both humans<sup>153,154,155</sup> and nonhuman primates,<sup>156</sup> endometriosis tends to cluster within families, suggesting that genetic factors probably influence susceptibility to developing endometriosis. The disease frequently is observed in monozygotic and dizygotic twin pairs<sup>157,158,159</sup> and exhibits a similar age of onset in affected nontwin sisters.<sup>160</sup> **Endometriosis is 6 to 7 times more prevalent among the first-degree relatives of affected women than in the general population.**<sup>161,162,163,164</sup> All of these observations suggest that endometriosis has a genetic foundation and that a predisposition to the disease is inherited as a complex genetic trait for which the phenotype reflects interactions between allelic variants of susceptibility genes and environmental factors.<sup>165,166</sup> Gene expression profiling has identified candidate susceptibility genes relating to implantation failure, infertility, and progesterone resistance.<sup>167,168</sup> Family linkage studies and genome-wide association (GWA) studies have identified several risk loci for endometriosis.<sup>169,170,171,172,173,174,175,176</sup> However, the precise genes and their role in endometriosis have not been fully elucidated. In total, the contribution of individual loci identified in the GWA studies explains only a very small percentage of endometriosis cases. Endometriosis is likely a complex polygenic disease involving multiple loci, each with a small effect size.

Recently, a polymorphism in the K-ras gene was reported in a subset of women with resistant endometriosis.<sup>177</sup> K-ras is a signal transduction molecule mutated in several cancers, leading to increased cell proliferation, survival, and migration. In mice expressing an oncogenic variant, spontaneous endometriosis develops, and increased expression of KRAS was found in the eutopic endometrium of women with endometriosis.<sup>178</sup> It is important to note that this polymorphism is likely associated with a more aggressive form of endometriosis in women, rather than the spontaneous development of endometriosis. Overall, it appears more likely that altered gene expression in endometriotic lesions is acquired, as can be seen in animal models of the disease where normal endometrium (i.e., no genetic predisposition to disease) is transplanted into the peritoneal cavity.<sup>56,179</sup>

# Molecular Mechanisms

While the exact molecular mechanism of endometriosis remains elusive, given the phenotype of endometriosis, it seems plausible that genes predisposing to the development of endometriosis might include any that direct processes controlling the survival of detached endometrial cells, their attachment to and invasion of peritoneal surfaces, proliferation, neovascularization, or the inflammatory response. The ectopic endometrium of women with endometriosis exhibits abnormal expression of numerous gene products that are relevant to the pathogenesis of the disease. Compared to normal endometrium, ectopic endometrial implants produce excessive amounts of estrogen, prostaglandins, and cytokines.<sup>180,181,182</sup> Similar but subtler abnormalities are observed in the eutopic endometrium of women with endometriosis. **These observations suggest that abnormalities, either intrinsic or acquired, to the endometrium of women who develop endometriosis may predispose to cell survival, ectopic implantation, proliferation, and chronic inflammation.**

Retrograde menstruation occurs in most women, but endometriosis develops in only a few. The survival of refluxed endometrial debris might result from immune dysfunction, as discussed above, or may reflect a molecular abnormality in the eutopic endometrium of women with endometriosis,<sup>183</sup> as discussed below. In any case, eutopic endometrial cells from women with endometriosis are resistant to apoptosis, which is the normal but complex gene-regulated physiologic process of programmed cell death that contributes to endometrial breakdown and turnover during the late secretory and menstrual phases of the cycle.<sup>184,185</sup> Ectopic endometrium appears even more resistant to apoptosis.<sup>186</sup> **Resistance to apoptosis may improve the survival of endometrial cells entering the peritoneal cavity and also help to explain why ectopic endometrium is resistant to macrophage-mediated immune surveillance and clearance.**

In normal women, levels of endometrial estrogen and prostaglandin E<sub>2</sub> (PGE<sub>2</sub>) production are low because activity of the enzymes aromatase (mediating estrogen synthesis) and cyclooxygenase-2 (COX-2, mediating prostaglandin synthesis) is low. Moreover, during the secretory phase of the cycle, progesterone stimulates 17 $\beta$ -hydroxysteroid dehydrogenase (17 $\beta$ HSD) activity, which converts estradiol to the less potent estrogen, estrone.<sup>18</sup> In women with endometriosis, aromatase and COX-2 activity are increased in eutopic endometrium and greatly elevated in ectopic endometrial tissue implants. Tissue levels of estradiol are high, due to increased aromatase and decreased 17 $\beta$ HSD activity, and tissue levels of PGE<sub>2</sub> are increased because COX-2 activity is elevated.<sup>18</sup> **The eutopic endometrium and ectopic endometrium of women with endometriosis thus differ from normal endometrium in at least three distinct and**



important ways (as discussed in the section that follows), exhibiting (1) high local estrogen production, (2) high local prostaglandin production, and (3) resistance to the actions of progesterone.

## Estrogen Production

There is little question that estrogen plays an important role in the pathogenesis of endometriosis. With rare exception, the disease arises only after menarche and regresses after menopause.<sup>187</sup> **Substantial evidence indicates that both estrogen production and metabolism are altered in endometriosis in ways that promote the disease.**<sup>18,188,189</sup>

Estrogen in women with endometriosis derives from three major sources. As in normal women, estrogen is secreted by the ovary into the circulation and released directly into the peritoneal cavity at ovulation and is produced in adipose and skin via conversion of circulating androgens. However, in women with endometriosis, substantial amounts of estrogen also are synthesized locally, in endometriotic tissue, which expresses a complete set of steroidogenic enzymes, including aromatase.<sup>190</sup>

The overproduction of estrogen in endometriotic stromal cells is linked with another of the functional abnormalities observed in the tissue, high local production of prostaglandins. PGE<sub>2</sub> stimulates the expression of all of the genes encoding the steroidogenic enzymes required for synthesis of estradiol from cholesterol in endometriotic stromal cells, including, in particular, STAR (encoding the steroidogenic acute regulatory protein, STAR) and CYP19A1 (encoding aromatase).<sup>190</sup> Stromal cells in both normal and ectopic endometria express all of the PGE<sub>2</sub> receptor subtypes (EP<sub>1</sub>, EP<sub>2</sub>, EP<sub>3</sub>, and EP<sub>4</sub>).<sup>188</sup> In endometriotic stromal cells, activation of the EP<sub>2</sub> receptor (by PGE<sub>2</sub>) increases intracellular levels of cyclic adenosine monophosphate (cAMP), which induces STAR and CYP19A1 expression.<sup>188,190,191</sup> PGE<sub>2</sub> or a cAMP analog increases STAR and aromatase levels and activity in endometriotic stromal cells, but not in normal endometrial stromal cells.<sup>182,190,191</sup> These observations indicate that PGE<sub>2</sub>- and cAMP-dependent steroidogenesis in endometriotic stromal cells requires downstream effectors that are absent or opposed by other inhibitory mechanisms in normal endometrial stromal cells, which exhibit no steroidogenic activity.

The key downstream effector molecule in endometriotic tissue is steroidogenic factor-1 (SF-1), which is absent in normal endometrium. In endometriotic stromal cells exposed to PGE<sub>2</sub>, SF-1 binds to and assembles an enhancer transcriptional complex, which interacts with the promoters of STAR and CYP19A1 and induces their expression.<sup>190</sup> In normal endometrial stromal cells, the absence of any steroidogenic

response to PGE<sub>2</sub> can be attributed to the absence of SF-1 and to the presence of transcriptional inhibitors of the STAR and CYP19A1 gene promoters. These repressors include the Wilms tumor 1 transcription factor (WT1)<sup>192</sup> and CCAAT/enhancer binding protein β (C/EBPβ), levels of which are much higher in normal endometrium than in endometriotic tissue. In the absence of SF-1, a transcriptional complex of inhibitors binds to and suppresses steroidogenic promoters in endometrial cells.<sup>190</sup>

## Prostaglandin Production

Prostaglandins are locally produced hormones involved in inflammation and pain. Both PGE<sub>2</sub> and prostaglandin F<sub>2α</sub> (PGF<sub>2α</sub>) are overproduced in the uterine and endometriotic tissues of women with endometriosis.<sup>193</sup> PGF<sub>2α</sub> stimulates both vasoconstriction and myometrial contractions, resulting in pain and dysmenorrhea. As in most cells, production of prostaglandin H<sub>2</sub> (PGH<sub>2</sub>) in the myometrium, endometrium, and endometriotic tissue is catalyzed by COX, which has two isoforms.<sup>194</sup> COX-1 primarily drives basal prostaglandin synthesis and COX-2 is involved in inflammation. PGH<sub>2</sub> is metabolized to other prostaglandins by cell-specific enzymes; in the uterus, PGH<sub>2</sub> is converted to PGF<sub>2α</sub> (by prostaglandin F synthase) and PGE<sub>2</sub> (by prostaglandin E synthase).<sup>193</sup>

In both ectopic and eutopic endometria in women with endometriosis, COX-2 is up-regulated to a greater extent than in endometrial stromal cells from disease-free women,<sup>195,196</sup> resulting in increased PGE<sub>2</sub> production that induces local estrogen synthesis (as discussed above) and causes inflammation, resulting in pain<sup>182,191,197,198</sup>; prostaglandin E synthase activity also may be increased.<sup>18</sup> COX-2 expression and PGE<sub>2</sub> production in uterine and endometriotic tissues are stimulated by IL-1b, PGE<sub>2</sub> (an autocrine action), VEGF, and estradiol (via estrogen receptor β).<sup>18,199,200,201</sup> Altogether, these complementary and redundant mechanisms maintain high levels of PGE<sub>2</sub> production in endometriotic tissue.

The high levels of PGE<sub>2</sub> in endometriotic tissue induce a classical inflammatory response, characterized by increased production of cytokines, metalloproteinases, and chemokines. Increased levels of inflammatory cytokines (IL-1β, IL-6, and TNF-α) promote adhesion of shed endometrial tissue to peritoneal surfaces, and proteolytic membrane metalloproteinases promote their implantation.<sup>140,167,180,202,203,204,205</sup> Increased levels of chemokines (monocyte chemoattractant protein 1, IL-8, and RANTES) attract increased numbers of granulocytes, NK cells, and macrophages,<sup>139,140,167,180,202,203,206</sup> and autoregulatory positive feedback loops

perpetuate the process.

## Progesterone Resistance

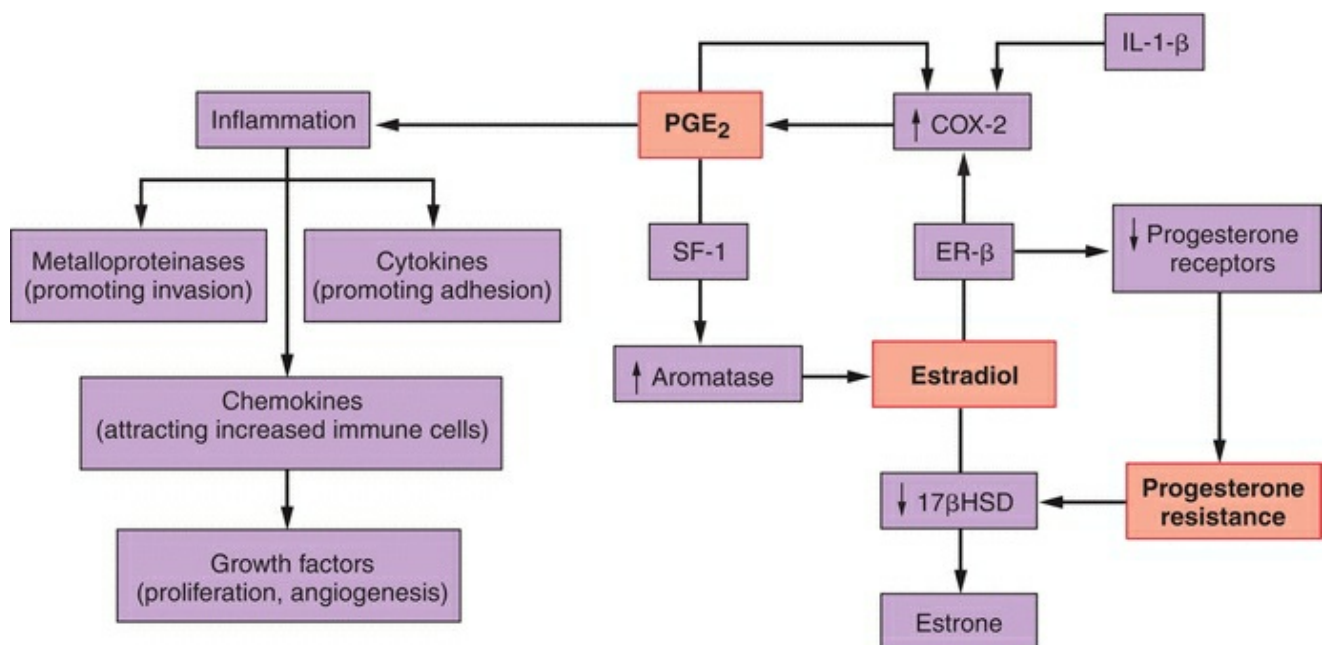
As discussed in [Chapter 3](#), the endometrium consists of two layers—the functionalis and basalis. The functionalis layer undergoes cycles of shedding and regrowth with each menstrual cycle, while the basalis layer remains and serves as a reservoir of cell for the functionalis layer. Estrogens and progesterone control the cellular composition and function throughout the menstrual cycle. Estrogen normally stimulates proliferation and endometrial thickening, while progesterone normally triggers inhibition of estrogen-dependent proliferation and induces decidualization of stromal cells, counteracting estrogens effects.<sup>18</sup> In the normal menstrual cycle, progesterone induces differentiation of both endometrial epithelial and stromal cells.<sup>207,208,209</sup> In the epithelium, progesterone stimulates secretion, and in the stroma, progesterone induces decidualization. Progesterone acts as an antiestrogen in a paracrine fashion, by stimulating retinoic acid production in the stroma,<sup>210,211,212</sup> which then induces 17 $\beta$ HSD activity in the epithelium,<sup>213,214,215,216</sup> resulting in the conversion of estradiol to the less potent estrogen, estrone. Although circulating progesterone levels in women with endometriosis are similar to those of women without endometriosis, ectopic lesions do not respond appropriately to progesterone.<sup>217</sup> Progesterone resistance was first suggested following studies demonstrating that progesterone treatment did not cause conversion of estradiol to the less potent estrone.<sup>218</sup> Similarly in endometriotic stromal cells, progesterone does not induce retinoic acid production,<sup>219,220</sup> resulting in reduced epithelial 17 $\beta$ HSD activity. As a result, tissue estradiol levels are elevated because high local aromatase activity drives production, and low 17 $\beta$ HSD activity impairs its metabolism.<sup>221</sup> In addition, progesterone-induced prolactin production is reduced in ectopic endometrium, offering further support of progesterone resistance.<sup>221</sup>

Progesterone mediates its effects through progesterone receptors (PR) A and B, which function as ligand-activated transcription factors. Aberrant expression of the two PR isoforms may explain the altered response to progesterone (i.e., progesterone resistance), and Attia and colleagues were the first to demonstrate decreased PR-B compared to PR-A expression in endometriotic lesions.<sup>222</sup> PR-A is a dominant repressor of PR-B, whereas PR-B has strong ligand-induced transcriptional activity.<sup>223</sup> During the normal menstrual cycle, levels of both PR-A and PR-B increase progressively during the proliferative phase and decrease after ovulation, indicating that estradiol stimulates PR production, yet in endometriotic tissues, this trend is not followed.<sup>18</sup> Moreover, endometriotic tissue contains lower levels of PR than does normal endometrium, thus suggesting that progesterone resistance is mediated in part by

decreased PR.<sup>191,222,224,225</sup>

Additional research has identified several other potential mechanisms of progesterone resistance.

As noted earlier, endometriosis is a chronic inflammatory state. Progesterone normally acts as an anti-inflammatory agent in uterine cells. In endometriosis, there is an influx of proinflammatory cytokines, activating nuclear factor kappa-light-chain-enhancer of activated B (NF- $\kappa$ B) cells. NF- $\kappa$ B proteins are transcription factors controlling genes involved in cell proliferation, adhesion, apoptosis, and inflammation. NF- $\kappa$ B accentuates the inflammatory response seen in endometriosis and antagonizes the effects of progesterone.<sup>226</sup> NF- $\kappa$ B is hypothesized to be chronically activated in endometriosis.<sup>227</sup> The ultimate effect is decreased responsiveness to progesterone, leading to a chronic cycle of increased NF- $\kappa$ B expression with decreased PR expression and decreased progesterone action. The proinflammatory environment may also adversely affect PR function through alterations in its chaperone proteins, as well as receptor coregulators.<sup>228,229,230</sup> Gene expression profiling of the endometrium of women with and without endometriosis has identified a number of genes linked to the actions of progesterone that are down-regulated (in those with endometriosis) during implantation when progesterone levels normally peak suggesting that the eutopic endometrium of women with endometriosis also is progesterone resistant (**Figure 32.1**).<sup>167,168</sup>



**FIGURE 32.1**

# Epigenetic Changes

Epigenetic changes involving DNA methylation, histone methylation/acetylation, as well as changes in coregulators (activators, repressors, enhancers, microRNAs [miRNAs]) may contribute to progesterone resistance through regulation of genes involved in endometrial differentiation. Homeobox A10 (HOXA10) is hypermethylated (and thus silenced) in eutopic endometrium of women with endometriosis.<sup>56</sup> HOXA10 is a target gene of progesterone and is necessary for implantation. In women with endometriosis, HOXA10 does not exhibit the normal peak in expression following ovulation.<sup>179</sup> The PR-B promoter site is also hypermethylated in ectopic endometrium of women with endometriosis, explaining another mechanism by which PR expression is lower in women with endometriosis, resulting in progesterone resistance.<sup>231</sup> In knockout studies, absence of PR-B results in unchecked proliferation of immortalized endometrial stromal cells, which in endometriosis may explain to some extent the ability of lesions to implant and grow (**Figures 32.1**).<sup>232</sup>

Additional support for a role of altered methylation/epigenetic changes comes from work by Wu et al.,<sup>233</sup> demonstrating overexpression of DNA methyltransferases (which catalyze DNA methylation) in human ectopic endometrium, suggesting that aberrant methylation patterns contribute to the endometriosis phenotype. Furthermore, the very high levels of SF-1 observed in endometriotic tissue (>12,000 times greater than in normal endometrium) appear related to a cytosine-phosphate-guanine (CpG) island at its promoter, which is heavily methylated in normal endometrial stromal cells and unmethylated in endometriotic stromal cells.<sup>234</sup> Whereas an inhibiting transcription factor binds to the methylated SF-1 promoter, preventing its interaction with transcriptional activators, a stimulating transcription factor binds to the unmethylated SF-1 promoter in endometriotic cells and activates it.<sup>235</sup>

The more than 100-fold higher levels of ER- $\beta$  in endometriotic tissue, compared to normal endometrium, are also associated with hypomethylation of a CpG island at the promoter region of the ER- $\beta$  gene, causing high levels of expression. In endometriotic stromal cells, ER- $\beta$  occupies the ER- $\alpha$  promoter and suppresses its activity. ER- $\beta$  also binds to the PR promoter, which down-regulates PR expression, leading to progesterone resistance.<sup>236</sup>

Alterations in microRNA (miRNA) expression represent another mechanism of epigenetic regulation. miRNAs are small, noncoding RNA molecules that bind to mRNA where they block translation or degrade mRNA, thereby inhibiting protein expression. Several miRNAs are aberrantly expressed in endometriosis. These miRNAs increase inflammation by stimulating cytokine production in macrophages. miRNA-9,<sup>128</sup> predicted to target a gene coding an antiapoptotic protein, is overexpressed in the

eutopic endometrium of women with endometriosis. Similarly, miRNA-135 is differentially expressed in endometriosis and endometrium of women with endometriosis leading to impaired endometrial receptivity. miRNA-196a<sup>237</sup> was also overexpressed in the eutopic endometrium of women with endometriosis, with PR-B (its target) significantly decreased. Similarly, miRNA-29c was found to be increased in ectopic endometrium—its target is FK506-binding protein (a progesterone-regulated protein responsible for decidualization), further implicating a role for epigenetic modifications in mediating progesterone resistance. miRNA let7 is decreased in endometriosis leading to enhanced expression of KRAS and other genes that increase invasion and proliferation.<sup>177,238</sup> miRNAs are emerging as key regulators of endometriosis pathogenesis.

## Key Points

The working molecular model for the pathogenesis of endometriosis centers on the following:

- Increased survival of refluxed endometrial cells (resistance to apoptosis), inducing inflammatory and immunologic changes.
- Functional abnormalities in eutopic and ectopic endometrial cells (high local production of estrogen and prostaglandins, progesterone resistance).
- Epigenetic modifications (hypomethylation of the promoters for SF-1 and ER- $\beta$ , hypermethylation of PR-B, HOXA10, and aberrant miRNA expression). Ultimately, inflammatory and immune responses, angiogenesis, apoptosis, and progesterone response are altered in ways that promote the survival, attachment, and proliferation of ectopic endometrial tissue.

# Mechanisms of Pain

Pain is one of the most common symptoms associated with endometriosis. The mechanisms involved are difficult to determine, for a number of reasons. Pain itself is subjective and difficult to measure, especially when it is chronic. Chronic pelvic pain, defined as the presence of pain below the umbilicus for more than 6 months, is a common gynecologic problem, accounting for up to 10% of gynecologic office visits.<sup>14</sup> In endometriosis, pelvic pain is most often chronic and associated with dysmenorrhea in 50–90% of cases; dyspareunia, deep pelvic pain, and lower abdominal pain (with or without back/groin pain) are also common.<sup>14</sup> The pain usually worsens over time and can change in pattern.<sup>14</sup> When bladder and bowel symptoms are present, they are usually cyclic.<sup>239</sup> In addition, those having disease adjacent to or within the rectal wall also may have dyschesia.<sup>240</sup>

The pain associated with endometriosis has been attributed to three primary mechanisms:

- The direct and indirect effects of focal bleeding from endometriotic implants
- The actions of inflammatory cytokines in the peritoneal cavity
- Irritation or direct infiltration of nerves in the pelvis

Among these, neural irritation or invasion has received the majority of recent attention. **The intensity of pain associated with deep infiltrating endometriosis relates to the depth of penetration and to the proximity or direct invasion of nerves.**<sup>241,242,243,244</sup>

Whereas neural inflammation or invasion might explain the pain of women with deep infiltrating endometriosis, it cannot be the mechanism that produces pain in women who have superficial peritoneal/ovarian disease.<sup>239</sup> **The pain associated with mild disease more likely relates to inflammation resulting from cyclic focal bleeding in and around peritoneal implants or from the actions of inflammatory cytokines released by the larger numbers of macrophages and other immune cells in the peritoneal fluid of women with endometriosis.** However, there is no correlation between stage, site, or the morphologic characteristics of pelvic endometriosis and pain.<sup>245,246</sup> The explanation for why many women with advanced endometriosis have little or no pain and those with mild disease may have incapacitating pain remains unclear. The cause may relate to the fact that severe disease is generally chronic and may be less metabolically active. There also is evidence to suggest that persistent neural input from endometriotic tissues may cause central sensitization of the nociceptive system (neurons that receive painful stimuli), manifested by somatic hyperalgesia (increased sensitivity to pain) and areas of referred pain in some women

with endometriosis.<sup>247</sup> What is not known, however, is if endometriosis directly causes central sensitization or if some women with endometriosis are already sensitized, offering an explanation for experiencing pain from minimal disease. In a murine model of endometriosis, it was found that endometriosis induced pain sensitization by modulating gene expression in regions of the brain controlling pain response.<sup>248</sup>

One additional mechanism that may be involved in the pain associated with endometriosis relates to evidence that the hormonal milieu influences pain perception. Numerous studies have examined measures of pain perception across the menstrual cycle. A meta-analysis including 16 such studies concluded that somatic sensory pain thresholds and tolerance are near their lowest levels just prior to and during menses.<sup>249</sup> Interestingly, although perhaps not surprisingly, estradiol itself increases endometriosis-associated pain, likely through lesion growth. Aromatase expression in endometriotic lesions may explain recurrent disease/pain even when ovarian-produced estradiol levels are low.<sup>250</sup> Conversely, progesterone modulates pain by decreasing neuronal activity (as seen with high doses of progestins).<sup>251</sup>



# Mechanisms of Infertility

Endometriosis is strongly associated with infertility; the prevalence of endometriosis increases dramatically to as high as 50% in women with infertility, and 30–50% of women with endometriosis have infertility.<sup>4</sup> The fecundity rate in young women with untreated endometriosis is estimated to be anywhere from 2% to 10%, compared with 20% of normal reproductive-age couples without infertility.<sup>4</sup> Numerous observations support a relationship between endometriosis and infertility:

- The overall prevalence of endometriosis is greater in infertile than in fertile women.<sup>15,16</sup>
- Infertile women are more likely than fertile women to have moderate to severe disease<sup>16</sup>; the prevalence of minimal endometriosis in infertile women with normal and azoospermic male partners is comparable.<sup>252</sup>
- Although reduced to a similar extent in untreated women with minimal and mild endometriosis and women with unexplained infertility, monthly fecundity decreases further with increasing severity of disease.<sup>253,254,255,256,257</sup>
- Monthly fecundity of women with minimal and mild endometriosis receiving treatment with exogenous gonadotropin stimulation and intrauterine insemination (partner sperm) is lower when compared to women without disease.<sup>258,259</sup>
- Women with minimal and mild endometriosis are significantly more likely to conceive after surgical treatment than untreated women.<sup>260,261</sup>
- IVF pregnancy rates are negatively correlated with endometriosis severity.<sup>262</sup>

**Taken together, these observations support the conclusion that endometriosis decreases fertility to an extent that correlates roughly with the severity of disease.**

Infertility associated with endometriosis has been attributed to several mechanisms, including distorted anatomy, inflammation, and aberrant endometrial gene expression. The distorted anatomy can inhibit or prevent ovum release and capture after ovulation, and there is reasonably good experimental evidence that endometriosis decreases fertility when it results in grossly distorted pelvic anatomy. In monkeys with peritoneal autografts of endometrium, cumulative pregnancy rates were significantly lower in animals that developed moderate or severe endometriosis (12%) than in others with minimal or mild disease or in controls (40%), and none of the animals with ovarian adhesions conceived.<sup>263</sup> Similarly in a mouse endometriosis model, fertility was inversely correlated with the amount of induced disease. Furthermore, decreased fertility in women with advanced endometriosis also could result from premature depletion of the ovarian follicular pool (due to ovarian surgery or destruction).<sup>264,265,266</sup>

Excess production of prostaglandins, metalloproteinases, cytokines, and chemokines results in chronic inflammation that impairs ovarian, tubal, or endometrial function, leading to disorders of folliculogenesis, fertilization, or implantation. The presence of endometriomas (and resultant inflammation) affects oocyte production and ovulation, while the peritoneal inflammatory milieu itself can also damage oocytes and sperm, decrease tubal motility, and have toxic effects on an embryo.<sup>267,268</sup> In the endometrium, the abnormal presence of aromatase and progesterone resistance can cause an increased and unopposed estrogenic state, which adversely affects endometrial development and receptivity for implantation.<sup>188,269</sup> Progesterone resistance also results in constitutively active matrix metalloproteinases.<sup>270</sup> Matrix metalloproteinases are usually inhibited by progesterone in the secretory phase; however, in endometriosis, their chronically active state can lead to inappropriate matrix breakdown that does not support implantation. In addition, Wnt7a (involved in estrogen-mediated uterine growth in mice likely through epithelial-stromal signaling) is up-regulated in the eutopic endometrium.<sup>167,271</sup> It is postulated that aberrant activation of the Wnt pathway negatively impacts endometrial development during the time of the implantation window, likely by adversely affecting the normal epithelial-stromal polarity.<sup>272,273</sup> There is also increasing evidence that ectopic implants can lead to implantation failure through aberrant endometrial gene expression in the eutopic endometrium. An example of this is the HOXA10 gene, expression of which is necessary for endometrial receptivity.<sup>274</sup> In a murine model of endometriosis, the presence of ectopic lesions resulted in decreased expression of HOXA10 in the eutopic endometrium of these mice.<sup>56</sup> In women without endometriosis, cyclical endometrial expression of this gene peaks during the window of implantation in response to estrogen and progesterone.<sup>275,276,277,278</sup> However, women with endometriosis do not exhibit the midluteal rise as would be expected, which may partially explain their infertility.<sup>273</sup> Another explanation could be that the reprogrammed and ectopic cells can migrate from the ectopic implants back to the eutopic endometrium.<sup>279</sup> Such bidirectional movement between eutopic and ectopic tissue could lead to the aberrant gene expression in the eutopic tissue and subsequent implantation failure. Similarly, stem cells may travel from implants to eutopic endometrium, but with improper incorporation into endometrium.<sup>279,280</sup> Lastly, significant suppression of  $\beta 3$  integrin has been reported in the endometrium of women with early-stage endometriosis.<sup>281</sup> This decrease in  $\beta 3$  integrin expression may be associated with impaired embryonic-endometrial interactions.

**The association between endometriosis is likely multifactorial, involving mechanical, inflammatory, cell signaling, and epigenetic origins.** Results of the many observational studies of IVF outcomes in women with endometriosis have varied but offer some useful insights. A 2002 meta-analysis of observational studies concluded that

infertile women with endometriosis were less likely to achieve success than women with tubal factor infertility (OR = 0.56, CI = 0.44–0.70); outcomes were worse in severe than in mild disease.<sup>282</sup> The ovarian response to gonadotropin stimulation in women with endometriosis was less robust than in women with tubal disease; both the peak estradiol concentration and number of oocytes retrieved were lower. Fertilization and implantation rates also were decreased, compared to those in women with all indications for IVF or to women with isolated tubal factor infertility.<sup>282</sup> The results further suggested that the adverse effects of endometriosis on fertility were not related solely to anatomical factors. Compared directly, women with severe endometriosis had a lower peak estradiol level, oocyte yield, pregnancy rate, and implantation rate than women with mild disease. In contrast, fertilization rates in women with advanced endometriosis were higher than in those with mild disease.<sup>282</sup> In a more recent 2013 meta-analysis of 27 observational studies, it was found that fertilization rates were significantly reduced in stage I/II of endometriosis, as were implantation rates and clinical pregnancy rates in stage III/IV endometriosis.<sup>283</sup> However, results of these analyses remain controversial, as subsequent studies have yielded conflicting data, observing outcomes not significantly different from those in women with unexplained infertility.<sup>284,285</sup> In a population-based retrospective cohort study of cycles from the Society for Assisted Reproductive Technology (SART) Clinical Outcome Reporting database from 2008 to 2010, women with isolated endometriosis (11% of study sample) had comparable live birth rate to women with other infertility diagnoses; the majority of women with endometriosis had a concomitant infertility diagnosis, and these women had lower implantation rates.<sup>286</sup> Data from 2015 SART indicate that the average live birth rate per retrieval of patients undergoing IVF-embryo transfer was 43.9% in women with endometriosis. Live birth rates were comparable to those for women with diagnoses of tubal factor (43%), male factor (45%), and unexplained infertility (49%).<sup>287</sup> It is important to note, however, that there is decreased detection and reporting of endometriosis; laparoscopy is no longer a routine part of the infertility evaluation leading to missed diagnosis, especially of mild to moderate disease. While endometriosis was detected in 40–50% of infertile women undergoing laparoscopy as part of the evaluation, it is now reported in under 5% of IVF patients.

The overall lower implantation and pregnancy rates observed in women with endometriosis after IVF could reflect poor oocyte quality and subsequent embryogenesis or decreased endometrial receptivity. Studies of IVF outcomes in donor oocyte recipients offer a means to distinguish the two possibilities. Donor oocytes from healthy women yield similar results in recipients with and without endometriosis; however, those with ovarian insufficiency or who are at the end of the reproductive age range are likely seeing spontaneous regression of disease; this cannot rule out an implantation defect as most data suggest the existence of an endometrial defect in endometriosis.

Oocytes from women with endometriosis yield poorer results than those from healthy donors in disease-free recipients.<sup>288,289,290,291,292</sup> Embryos derived from oocytes retrieved from women with endometriosis also have fewer blastomeres and exhibit a higher incidence of arrested and abnormal development than those derived from women without the disease.<sup>291,293</sup> Taken together, these observations suggest that the lower implantation and pregnancy rates observed in women with endometriosis may result from both abnormalities of oocyte quality and subsequent embryogenesis and from altered endometrial receptivity.

A wide assortment of studies has been aimed at identifying differences in the follicular environment in women with and without endometriosis that might explain the presumed poor oocyte quality in women with the disease. Studies have compared the numbers and types of resident immune cells; the production of various hormones, growth factors, and cytokines; and the expression of numerous genes in follicular fluid and cultured granulosa cells obtained from women with and without endometriosis, but no consistent differences have been observed.<sup>294</sup>

Gene expression profiling (as discussed earlier) has identified a number of gene products that may be abnormally up- or down-regulated in the endometrium of women with endometriosis during the putative implantation window, including various cell adhesion molecules, matrix metalloproteinases, transcription factors, growth factors, enzymes, and steroid hormone receptors.<sup>167,168,295</sup> If endometriosis does have adverse effects on endometrial receptivity, evidence suggests they can be overcome by IVF treatment regimens in most women.

Retrospective studies have observed an increased risk for early pregnancy loss in women with endometriosis.<sup>296,297,298</sup> However, in appropriately controlled studies, miscarriage rates in untreated women with endometriosis have been in the ranges normally expected and no higher than in treated women.<sup>260,299,300</sup>

# DIAGNOSIS OF ENDOMETRIOSIS

---

Classically, the diagnosis of endometriosis requires surgical visualization of lesions and histologic evidence of ectopic endometrial glands and stroma. Although endometriosis is a common disorder, it remains difficult to diagnose. In a prospective study of over 1,000 women with and without endometriosis, there was a 6.7-year delay between symptom presentation and diagnosis of endometriosis.<sup>6</sup> Unfortunately, despite substantial advances in our understanding of the pathogenesis of endometriosis, there is not yet any reliable noninvasive alternative to laparoscopy for diagnosis of the disease. Current research is aimed at identifying potential biomarkers for the disease.<sup>301</sup>

# Clinical Diagnosis

The clinical symptoms of endometriosis include dysmenorrhea, nonmenstrual pelvic pain (NMPP), dyspareunia, dyschezia, cyclic bowel or bladder symptoms, infertility, and chronic fatigue. A 2008 cross-sectional survey of 1,000 women with endometriosis found that dysmenorrhea (79%) and pelvic pain (69%) were the most common symptoms leading to diagnosis.<sup>302</sup> Comparing women with minimal and mild endometriosis to those with more advanced stages of disease, dyspareunia was significantly more common in women with limited disease (51% vs. 39%), whereas infertility (22% vs. 30%) and an ovarian mass (7% vs. 29%) led to a diagnosis more often in those with advanced endometriosis.<sup>302</sup> A large case-control study conducted in the United Kingdom comparing the prevalence of specific symptoms in women with and without endometriosis observed that a greater proportion of women with endometriosis had abdominal/pelvic pain, dysmenorrhea, or menorrhagia (73% vs. 20%).<sup>303</sup> Compared to controls, women with endometriosis had increased risks of abdominal/pelvic pain (OR = 5.2, CI = 4.7–5.7), dysmenorrhea (OR = 8.1, CI = 7.2–9.3), menorrhagia (OR = 4.0, CI = 3.5–4.5), infertility (OR = 8.2, CI = 6.9–9.9), dyspareunia and/or postcoital bleeding (OR = 6.8, CI = 5.7–8.2), ovarian cysts (OR = 7.3, CI = 5.7–9.4), irritable bowel syndrome (OR = 1.6, CI = 1.3–1.8), and pelvic inflammatory disease (OR = 3.0, CI = 2.5–3.6).<sup>303</sup> These data demonstrate that whereas specific symptoms are associated with endometriosis, the same symptoms are not uncommon in women without the disease. They also reveal that endometriosis can coexist with or be misdiagnosed as irritable bowel syndrome or pelvic inflammatory disease. It is not surprising that diagnosis can be delayed for several years.<sup>304</sup>

Dysmenorrhea and pain that are new in onset, progressive, or severe strongly suggest endometriosis.<sup>305</sup> The dysmenorrhea associated with endometriosis often begins before onset of menstrual flow and usually persists throughout menses, sometimes even beyond. The pain usually is diffuse, located deep in the pelvis, dull, and aching and may radiate to the back and thighs or be associated with rectal pressure, nausea, and episodic diarrhea.<sup>306</sup> Pain may be more common, severe, and associated with dyspareunia and painful defecation in women with deep infiltrating disease involving the cul-de-sac and rectovaginal septum.<sup>240,307,308,309</sup> Dyspareunia associated with endometriosis usually is new in onset and most intense with deep penetration immediately prior to menstruation.<sup>310,311</sup> One-half to two-thirds of women with endometriosis and pain have intermenstrual pain.<sup>245</sup>

**The severity of endometriosis does not correlate with the number and severity of symptoms; women with advanced disease may have few or no symptoms and those with minimal or mild disease may have incapacitating pain.**<sup>245,310,311</sup> However,

in women with deep infiltrating endometriosis, the severity of pain generally correlates with the depth and volume of disease.<sup>240,307,310</sup> Extrapelvic endometriosis may be associated with a wide assortment of cyclic symptoms that reflects the organs involved (abdominal scars,<sup>312,313</sup> the gastrointestinal and urinary tracts,<sup>78,314,315,316</sup> the diaphragm,<sup>317</sup> the pleura,<sup>318</sup> and peripheral nerves<sup>319</sup>).

**There has been a gradual shift toward diagnosing endometriosis on a clinical basis.<sup>320,321</sup> While surgery is currently required for definitive diagnosis, endometriosis should be suspected in any woman reporting symptoms of cyclic, progressively worsening pain. Furthermore, medical treatment of dysmenorrhea/clinically diagnosed endometriosis certainly is appropriate before considering surgical evaluation and treatment for suspected endometriosis.<sup>322</sup> A trial of treatment with a nonsteroidal anti-inflammatory drug (NSAID), ideally with a combined oral contraceptive (COC), progestin only contraceptive, or gonadotropin-releasing hormone (GnRH) antagonist, is reasonable when the symptoms do not suggest an acute process.**

## **Physical Examination**

Physical findings in women with endometriosis vary widely and, when present, can relate to the location and extent of disease.<sup>310</sup> The external genitalia are typically normal. Occasionally, speculum examination may reveal characteristic blue-colored implants or red proliferative lesions that bleed on contact, both usually in the posterior fornix. Whereas deep infiltrating endometriosis involving the rectovaginal septum frequently is palpable, it is not often visible and may have no obvious signs.<sup>308</sup> In addition, in moderate to severe disease, the uterus often is retroverted and can exhibit decreased mobility or fixation, suggesting involvement of the cul-de-sac. Women with ovarian endometriomas can have a tender, fixed, adnexal mass. Focal tenderness, thickening, induration, and nodularity of the uterosacral ligaments (palpable at the 4 o'clock and 8 o'clock positions at the base of the cervix) are the most common, and frequently the only, physical findings.<sup>323,324</sup> Physical examination has its greatest diagnostic sensitivity when performed during menstruation, but even then, a normal examination does not exclude the diagnosis.<sup>325</sup> **Overall, compared to surgical diagnosis of endometriosis, physical examination has relatively poor sensitivity, specificity, and predictive value and should not be used as a means to rule out endometriosis.<sup>326</sup>**

# Noninvasive Diagnostic Testing CA-125

CA-125 is a cell surface antigen expressed by derivatives of the coelomic epithelium (including the endometrium) and is well established as a useful marker for the monitoring of women with epithelial ovarian cancer. Levels of CA-125 often are elevated in women with advanced endometriosis,<sup>327,328,329</sup> but also during early pregnancy and normal menstruation, and in women with acute pelvic inflammatory disease or leiomyomata. Serum CA-125 concentrations vary somewhat across the menstrual cycle; in general, levels are highest during the menstrual phase and lowest during the midfollicular and periovulatory phases of the cycle.<sup>325,330,331</sup> However, studies of cycle-dependent assay sensitivity and reproducibility have yielded conflicting results, so there is no one best time to perform the test.<sup>326</sup>

Serum CA-125 has been inappropriately advocated as a screening test for diagnosis of endometriosis, but a meta-analysis including 22 studies using surgically diagnosed disease as the gold standard concluded that the marker performs rather poorly.<sup>332</sup> Cutoff values that provide 90% overall specificity have no more than 52% sensitivity.<sup>333</sup> As a screening test for advanced stages of endometriosis, stages III and IV have a sensitivity of 63% compared to 24.8% for stages I and II.<sup>333</sup> **Overall, the serum CA-125 concentration does not have the necessary sensitivity to be an effective screening test for the diagnosis of endometriosis.**

Whereas the serum CA-125 generally is not a reliable predictor of the effectiveness of medical therapy,<sup>334,335</sup> a sustained elevation of serum CA-125 after surgical treatment predicts a relatively poor prognosis.<sup>336,337</sup>

## Circulating microRNAs

Several studies have noted aberrant miRNA expression in cancers, cardiovascular disorders, inflammatory diseases, and gynecologic disease.<sup>338,339,340,341,342,343,344</sup> Thousands of miRNAs circulate in the bloodstream and hence offer the possibility to serve as precise biomarkers of disease.<sup>345</sup> While the mechanism by which miRNA levels are altered is not fully understood, their serum/plasma levels correlate with levels in cancer tissues, suggesting that miRNAs are shed from tissue and released into the circulation.<sup>346,347</sup> As mentioned earlier, miRNAs are differentially expressed in eutopic and ectopic endometria. Microarray expression profiling has also demonstrated altered systemic serum miRNA concentrations in women with endometriosis.<sup>301,348,349</sup> Recently, using a prospective case-control study, miRNA microarray and qPCR analysis of serum samples in women with and without endometriosis diagnosed at time of laparoscopy found that many miRNAs were aberrantly regulated in endometriosis.<sup>301</sup>



Measurement of these miRNAs may represent a novel, noninvasive diagnostic test for early detection and intervention of endometriosis, and is currently under development.

# Imaging

Transvaginal ultrasonography can be helpful in identifying women with advanced endometriosis. **Transvaginal ultrasonography can detect ovarian endometriomas, but cannot image pelvic adhesions or superficial peritoneal foci of disease.** Endometriomas can have varying ultrasonographic features but appear typically as cystic structures with diffuse low-level internal echoes surrounded by a crisp echogenic capsule. Some have internal septations or thickened nodular walls.<sup>350,351</sup> When the characteristic features are present, transvaginal ultrasonography has 90% or higher sensitivity and almost 100% specificity for detection of endometriomas.<sup>352,353</sup> Transvaginal or transrectal ultrasonography can be especially helpful when deep infiltrating disease involving the bladder, the uterosacral ligaments, or the rectovaginal septum is suspected.<sup>354,355,356,357,358,359,360,361</sup>

**Like transvaginal ultrasonography, magnetic resonance imaging (MRI) can be helpful in the detection and differentiation of ovarian endometriomas from other cystic ovarian masses, but cannot reliably image small peritoneal lesions.**<sup>356,362,363</sup> For detection of peritoneal implants, MRI is superior to transvaginal ultrasonography but still identifies only 30–40% of the lesions observed at surgery. For detection of disease documented by histopathology, MRI is approximately 70% sensitive and 75% specific.<sup>364</sup> The principal advantage MRI has over ultrasonography is its ability to distinguish more reliably between acute hemorrhage and degenerated blood products. Whereas endometriomas usually exhibit a relatively homogeneous high signal intensity on T1-weighted images and a hypointense signal on T2-weighted images (“shading”), acute hemorrhage generally has low signal intensity on both T1- and T2-weighted images.<sup>326</sup> However, an interval 6-week observation, during which hemorrhagic cysts will typically regress, followed by repeat TVUS accomplishes the same goal. Gadolinium contrast offers no additional diagnostic value.<sup>365</sup> MRI also can be used to aid in the diagnosis of deep infiltrating and rectovaginal disease.<sup>366</sup> **Neither ultrasound nor MRI can be used to rule out endometriosis.**

# Surgical Diagnosis

**Laparoscopy with histologic examination of excised lesions has traditionally been the gold standard for the diagnosis of endometriosis.** The optimal time during the menstrual cycle to perform laparoscopy is not clear, although some may recommend that surgery generally should not be performed during or within 3 months after hormonal medical treatment.<sup>354</sup> Greater awareness of the varied appearance of endometriotic lesions has doubled the frequency with which endometriosis is diagnosed with laparoscopy when a careful and systematic examination is performed.<sup>367,368</sup>

The classic peritoneal implant is a blue-black “powder- burn” lesion (containing hemosiderin deposits from entrapped blood) with varying amounts of surrounding fibrosis, typically observed on the ovaries and on peritoneal surfaces in the cul-de-sac, uterosacral ligaments, and ovarian fossa.<sup>369</sup> **However, the majority of implants are “atypical,” appearing white and opaque, red and flame-like, or vesicular.** Less commonly, disease may be found in ovarian adhesions, peritoneal defects, or involving the appendix.<sup>367,368,369,370,371</sup> Red lesions are highly vascular and proliferative and represent an early stage of disease.<sup>372</sup> Pigmented lesions represent more established or advanced disease. Both are metabolically active and more commonly associated with symptoms. White lesions are less vascular and active and less often symptomatic.<sup>372,373</sup> Studies involving serial laparoscopy have suggested a natural progression in the appearance of endometriotic lesions over time, and revealed that a variety of lesions may be observed at any one time in an individual.<sup>374,375</sup>

Strict histologic criteria will confirm the surgical diagnosis of endometriosis in approximately 50–65% of excised lesions.<sup>369,376</sup> When diagnosis is in doubt, biopsy of suspicious areas should be performed to prevent misdiagnosis; lesions that can be confused with endometriosis include endosalpingiosis, mesothelial hyperplasia, hemangiomas, adrenal rests, inflammatory changes (from infectious causes), and splenosis.<sup>377</sup> **Histologic examination of excised lesions can confirm surgical impressions and is preferred, but not required, to establish the diagnosis with reasonable certainty.** Conversely, a negative laparoscopy is relatively reliable for excluding endometriosis, although it cannot rule out microscopic disease.<sup>378</sup> Occult disease is not uncommon in women with pelvic pain; based on this, even laparoscopy cannot be considered a true gold standard for the diagnosis of endometriosis.

Endometriomas usually appear as smooth, dark cysts, typically associated with adhesions and containing a dense brown chocolate-like fluid (hemosiderin from ovarian/endometriotic hemorrhage).<sup>307,379</sup> Larger endometriomas frequently are multilocular. Careful visual inspection of the ovaries (and imaging) generally are highly

reliable for detection of endometriomas.<sup>380,381</sup> Whereas ovarian endometriomas usually are accompanied by numerous other visible peritoneal lesions,<sup>382</sup> deep infiltrating endometriosis is largely retroperitoneal, often not readily apparent, and frequently isolated; it may even represent a distinct entity, arising from müllerian rests within the rectovaginal septum.<sup>383,384</sup>

## Classification and Staging Systems

A uniform classification system for endometriosis that considers both the distribution and severity of disease is useful, because both treatment and prognosis in women with endometriosis are determined, to some extent, by the disease severity. A valid uniform classification also is crucial for comparing the results of treatment trials performed in different centers.

In 1979, the American Fertility Society (now the American Society for Reproductive Medicine, ASRM) introduced a classification system based on surgical findings at laparoscopy or laparotomy that was modeled after those used for grading malignant disease.<sup>385</sup> The system assigned a point score, based on the size, depth, and location of lesions and associated adhesions. The classification system was revised in 1985,<sup>386</sup> and again in 1996, to acknowledge the varying morphology of endometriosis and to improve consistency in scoring and the prognostic value for women with pain or infertility (**Figure 32.2**).<sup>387</sup> The current version of the revised classification system is the most widely accepted classification tool, but still has serious limitations.<sup>388</sup> Chief among them is the relatively poor correlation with clinical symptoms and pregnancy rates.<sup>389,390</sup> Further revisions of the classification scheme are anticipated as our understanding of the pathogenesis of infertility advances and likely will include empirically derived weights and thresholds to define stages of disease; other factors may be incorporated if they prove to have prognostic value.<sup>391</sup>

REVISED AMERICAN SOCIETY FOR REPRODUCTIVE MEDICINE CLASSIFICATION OF ENDOMETRIOSIS 1985

Patient's Name \_\_\_\_\_ Date: \_\_\_\_\_

Stage I (Minimal) 1-5 Laparoscopy \_\_\_\_\_ Laparotomy \_\_\_\_\_ Photography \_\_\_\_\_  
 Stage II (Mild) 6-15 Recommended Treatment \_\_\_\_\_  
 Stage III (Moderate) 16-40 \_\_\_\_\_  
 Stage IV (Severe) > 40 \_\_\_\_\_  
 Total \_\_\_\_\_ Prognosis \_\_\_\_\_

Peritoneum	ENDOMETRIOSIS	< 1 cm	1-3 cm	> 3 cm
		Superficial	1	2
	Deep	2	4	6
Ovary	R Superficial	1	2	4
	Deep	4	16	20
	L Superficial	1	2	4
	Deep	4	16	20
POSTERIOR CULDESAC OBLITERATION		Partial	Complete	
		4	40	
Ovary	ADHESIONS	< 1/3 Enclosure	1/3-2/3 Enclosure	> 2/3 Enclosure
	R Filmy	1	2	4
	Dense	4	8	16
	L Filmy	1	2	4
	Dense	4	8	16
	Tube	R Filmy	1	2
Dense		4	8	16
L Filmy		1	2	4
Dense		4*	8*	16

\*If the fimbriated end of the fallopian tube is completely enclosed, change the point assignment to 16.

Additional Endometriosis: \_\_\_\_\_  
 \_\_\_\_\_  
 \_\_\_\_\_

Associated Pathology: \_\_\_\_\_  
 \_\_\_\_\_  
 \_\_\_\_\_

To Be Used with Normal Tubes and Ovaries



To Be Used with Abnormal Tubes and/or Ovaries



Reprinted from **American Society for Reproductive Medicine**. Revised American Society for Reproductive Medicine classification of endometriosis: 1996. Fertil Steril 67:817-821, 1997, with permission from Elsevier.<sup>387</sup>

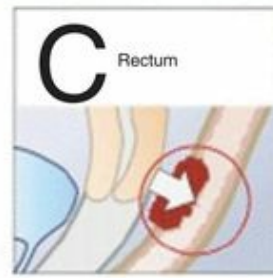
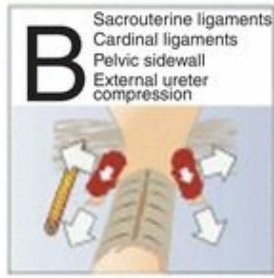
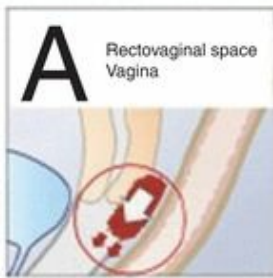
The classification of endometriosis used most commonly in clinical practice is descriptive and relatively simple:

- Stage I: Minimal endometriosis—isolated superficial disease on the peritoneal surface with no significant associated adhesions
- Stage II: Mild endometriosis—scattered superficial disease on the peritoneal surface and ovaries, totaling less than 5 cm in aggregate, with no significant associated adhesions
- Stage III: Moderate endometriosis—multifocal disease, both superficial and invasive (including endometriomas >1 cm), that may be associated with adhesions involving the fallopian tubes and/or the ovaries
- Stage IV: Severe endometriosis—multifocal disease, both superficial and invasive, including large ovarian endometriomas, usually associated with adhesions, both filmy and dense, involving the fallopian tubes, ovaries, and cul-de-sac

In 2005, the Enzian classification system was developed to better describe deep infiltrating lesions. Like the ASRM classification, it consists of four stages, which are further subdivided into three groups (**Figure 32.3**).<sup>392</sup> In 2009, a new staging system was proposed, called the endometriosis fertility index (EFI), by combining the factors that best predicted pregnancy (without IVF) after analysis of clinical and surgical data (275 variables) collected from 579 infertile patients with endometriosis.<sup>390</sup> The EFI score (0–10, with 0 representing the poorest and 10 the best prognosis) was validated by collecting comparable data from an additional 222 patients, calculating the score for each, and observing good correlation between actual and predicted (estimated from life table analysis) pregnancy rates. The key element of the new staging system, absent from its forerunners, is a numerical measure of functional anatomy, based on careful assessment of the tubes (extent of serosal injury, mobility, and patency), fimbriae (extent of injury, architecture), and ovaries (size, extent of surface injury). The EFI score predicts cumulative pregnancy rates over 3 years after surgery, which range from a low of 10% (EFI 0–3) to a high of 75% (EFI 9–10) (**Figure 32.4**).<sup>390</sup> Based on the original report, the method has promise as a clinical tool for developing treatment plans in infertile patients with a surgical diagnosis of endometriosis. Ultimately, the clinical utility of the EFI will hinge on additional independent validation and its general acceptance by clinicians. In 2017, the World Endometriosis Society met and developed consensus statements on the classification of endometriosis and proposed a classification system toolbox that could be used by all surgeons in each endometriosis surgical case.<sup>393</sup> This toolbox includes the revised ASRM criteria and the Enzian and the EFI classification systems.<sup>392</sup> The goal is to use these classification tools to ensure that clear information is obtained from the surgery, as well as enhance patient understanding of their diagnosis.<sup>393</sup>

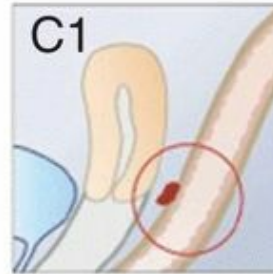
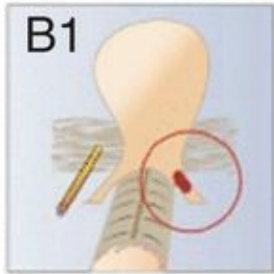
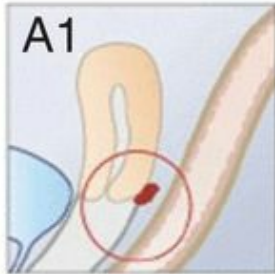
## Compartment

A, B or C

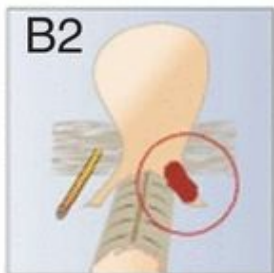
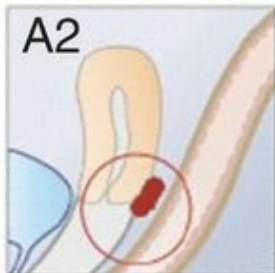


## Level

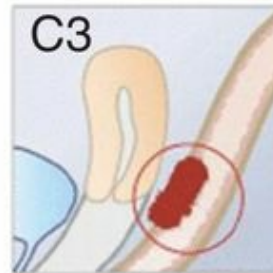
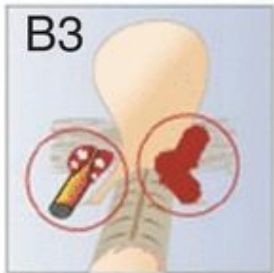
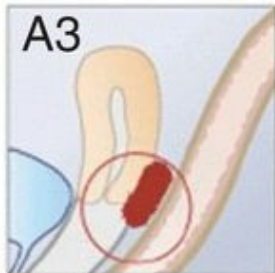
**1**  
< 1 cm



**2**  
1–3 cm

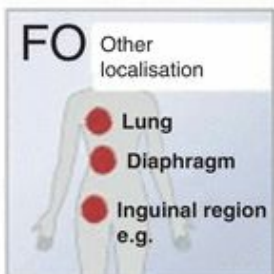
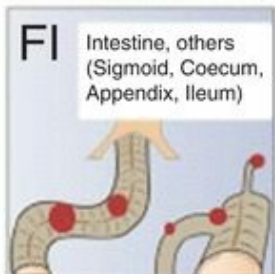
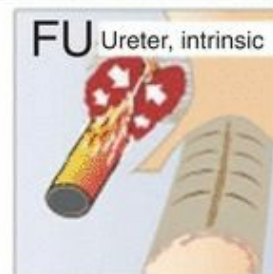
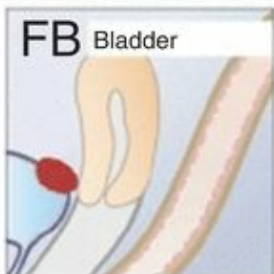
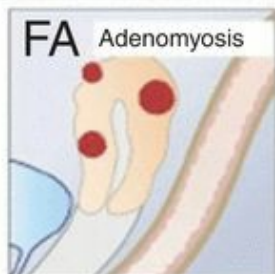


**3**  
> 3 cm



## F

Uterine  
and other  
extragenital  
deep infiltration  
endometriosis



From **Tuttles J, Keckstein U, Ulrich M, Possover KW, Schweppe M, Wustlich O, Buchweitz R, Greb O, Kandolf R, Mangold W, Masetti K, Neis G, Rauter N, Reeka O, Richter AE, Schindler M, Sillem V, Terruhn HR, Tinneberg**. ENZIAN-Score, a classification of deep infiltrating endometriosis. *Zentralbl Gynakol* 127(5):275–281, 2005, with permission. [392](#)



## ENDOMETRIOSIS FERTILITY INDEX (EFI) SURGERY FORM

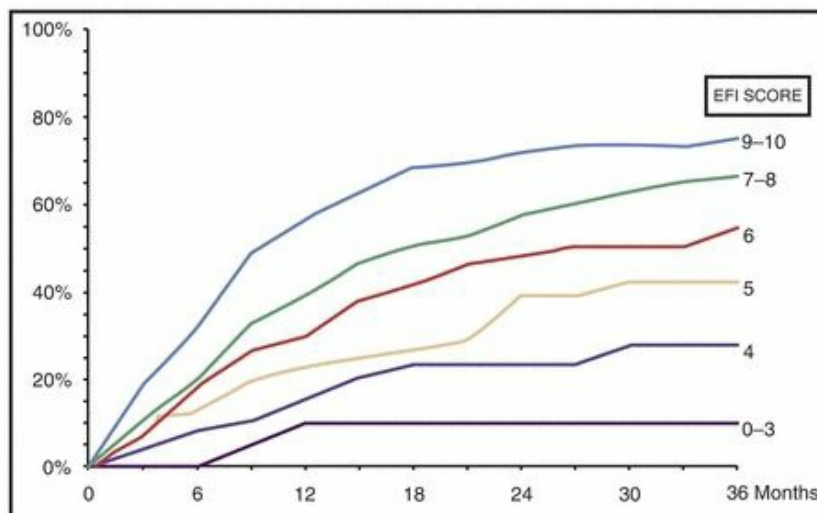
### LEAST FUNCTION (LF) SCORE AT CONCLUSION OF SURGERY

Score	Description		Left	Right	
4	= Normal	Fallopian Tube	<input style="width: 40px; height: 20px;" type="text"/>	<input style="width: 40px; height: 20px;" type="text"/>	
3	= Mild Dysfunction	Fimbria	<input style="width: 40px; height: 20px;" type="text"/>	<input style="width: 40px; height: 20px;" type="text"/>	
2	= Moderate Dysfunction	Ovary	<input style="width: 40px; height: 20px;" type="text"/>	<input style="width: 40px; height: 20px;" type="text"/>	
1	= Severe Dysfunction				
0	= Absent or Nonfunctional				
<p>To calculate the LF score, add together the lowest score for the left side and the lowest score for the right side. If an ovary is absent on one side, the LF score is obtained by doubling the lowest score on the side with the ovary.</p>			Lowest Score <input style="width: 40px; height: 20px;" type="text"/>	+ <input style="width: 40px; height: 20px;" type="text"/>	= <input style="width: 40px; height: 20px; border: 1px dashed black;" type="text"/>
			Left	Right	LF Score

## ENDOMETRIOSIS FERTILITY INDEX (EFI)

Historical Factors			Surgical Factors				
Factor	Description	Points	Factor	Description	Points		
<u>Age</u>			<u>LF Score</u>				
	If age is ≤ 35 years	2		If LF Score = 7 to 8 (high score)	3		
	If age is 36 to 39 years	1		If LF Score = 4 to 6 (moderate score)	2		
	If age is ≥ 40 years	0		If LF Score = 1 to 3 (low score)	0		
<u>Years Infertile</u>			<u>AFS Endometriosis Score</u>				
	If year infertile is ≤ 3	2		If AFS Endometriosis Lesion Score is < 16	1		
	If year infertile is > 3	0		If AFS Endometriosis Lesion Score is ≥ 16	0		
<u>Prior Pregnancy</u>			<u>AFS Total Score</u>				
	If there is a history of a prior pregnancy	1		If AFS total score is < 71	1		
	If there is no history of prior pregnancy	0		If AFS total score is ≥ 71	0		
<b>Total Historical Factors</b>			<b>Total Surgical Factors</b>				
			<input style="width: 60px; height: 25px;" type="text"/>	+	<input style="width: 60px; height: 25px;" type="text"/>	=	<input style="width: 60px; height: 25px;" type="text"/>
EFI = TOTAL HISTORICAL FACTORS + TOTAL SURGICAL FACTORS:			Historical		Surgical		EFI Score

### ESTIMATED PERCENT PREGNANT BY EFI SCORE

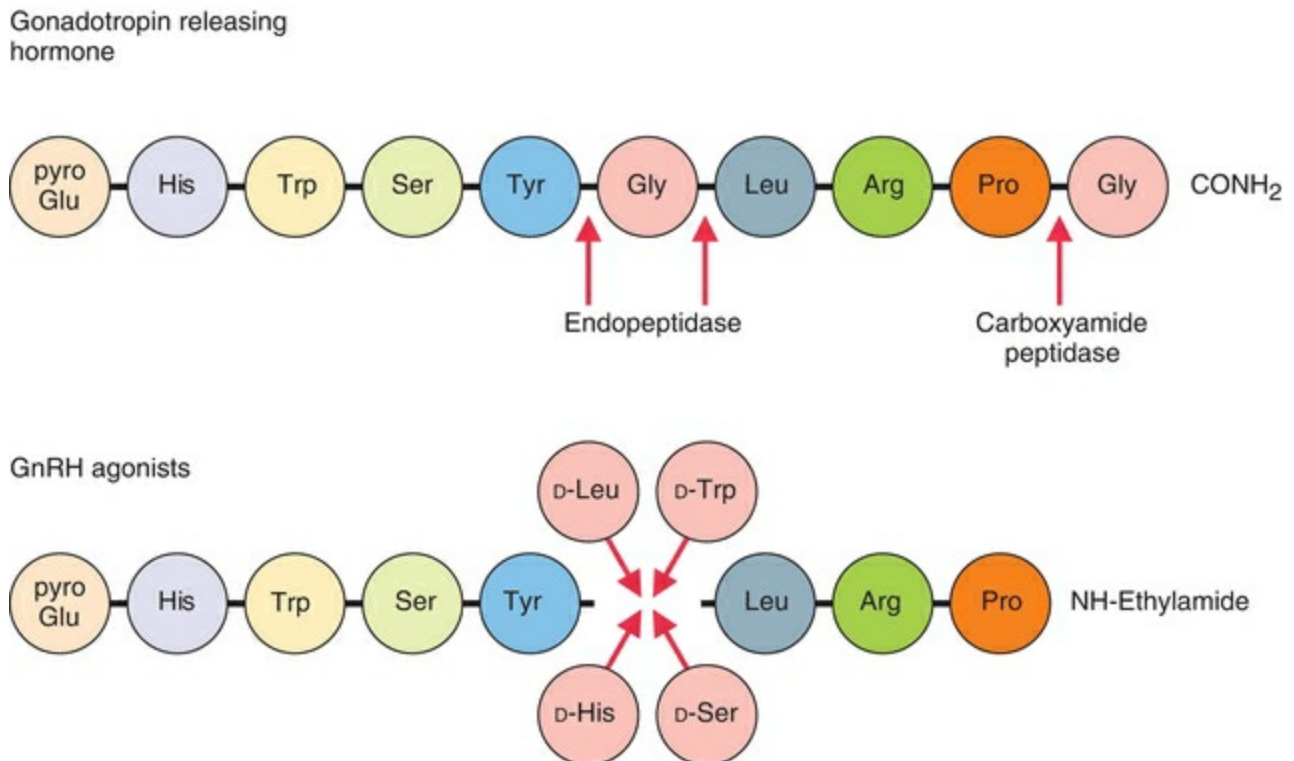


## Key Points

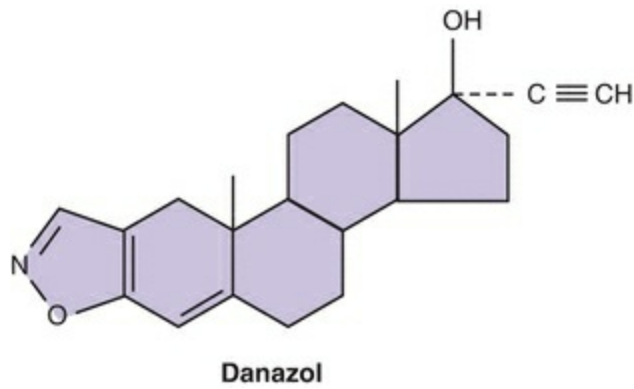
- Careful clinical evaluation can identify women likely to have endometriosis but has not traditionally been used to establish the diagnosis. Treatment may be initiated based on clinical diagnosis.
- Although a serum CA-125 concentration may provide corroborative evidence of disease, the sensitivity of the test is too low to make it an effective screening tool.
- Transvaginal ultrasonography and MRI are both highly sensitive and specific for detection of ovarian endometriomas but cannot reliably image peritoneal implants of disease.
- In the majority of women, the diagnosis of endometriosis ideally can be made after a careful and systematic history and physical examination, with laparoscopic examination infrequently needed for diagnosis alone.
- Laparoscopy should be considered a therapeutic option rather than necessary for diagnosis.

# TREATMENT OF ENDOMETRIOSIS

The treatment of endometriosis depends on its clinical manifestations, which currently fall into two categories: pelvic pain and/or infertility. Because both can be very difficult to assess objectively, the results of treatment trials must be interpreted carefully. To be truly informative, studies of the effects of treatments on pain should use a validated objective measure of pain, follow subjects over a prolonged interval because the recurrence of pain is time dependent, and employ a placebo control because the placebo effect in studies of pain is often quite large (30–50%). Studies of the effects of treatments on the volume of endometriosis are equally difficult to conduct and interpret because disease may regress spontaneously and also may recur or advance after discontinuation of therapy. Studies of the effects of treatments on fertility must consider that most women with endometriosis and infertility are only subfertile, not sterile; they can conceive, but do so less efficiently. Ideally, cycle fecundity over a defined interval of time should be compared to that in a group of similarly affected but untreated women ([Figures 32.5](#) and [32.6](#)).



**FIGURE 32.5**



**FIGURE 32.6**

Treatment for endometriosis can be expectant and can involve one or a combination of medical treatments, conservative or definitive surgery, or a combination of medical and surgical treatments. Expectant management generally is reserved for patients without significant symptoms and for those approaching menopause. However, even those with few symptoms benefit from treatment aimed at preventing progression of the disease.<sup>394</sup> Because endometriosis normally regresses after menopause, due to the marked decrease in ovarian estrogen production, perimenopausal women with mild symptoms may choose expectant management or treatment limited to nonnarcotic analgesics, for the short term. Young women with significant symptoms generally will require more aggressive medical or surgical treatment.

# Medical Treatment

Women with pelvic pain, suspected endometriosis, and no other indication for surgical treatment can be managed effectively with empiric medical treatment without establishing a surgical diagnosis.<sup>395</sup> Initial empiric medical therapy usually involves treatment with NSAIDs and oral contraceptives (OCs; combined or progestin only). If treatment with NSAIDs and OCs does not significantly improve pain, second- and third-line medical therapies or laparoscopic surgery is employed.

Traditional medical therapies for endometriosis have been based on Sampson's theory of retrograde menstruation and implantation and on the simple premise that ectopic endometrium may be expected to respond to treatment in much the same way as normal eutopic endometrium. Consequently, the objectives of treatment have been to reduce or eliminate cyclic menstruation, thereby decreasing peritoneal seeding and the likelihood that new implants will develop, and to suppress the growth and activity of the endometrium, anticipating that the same would occur in the endometriotic tissue derived from it. Interventions that reduce ovarian estradiol production are the most reliable ways to cause atrophy of endometriotic lesions and the most effective treatment for pain. These simple operational concepts have shaped medical treatments for endometriosis for decades, but our growing understanding of the pathogenesis of endometriosis at the molecular level is now beginning to suggest new treatment strategies aimed at the mechanisms of disease.

## Nonsteroidal Anti-Inflammatory Medications

Nonsteroidal anti-inflammatory medications are the most commonly used first-line medication for endometriosis, typically in conjunction with OCs. In a Cochrane review, when NSAIDs were compared to placebo, there was no evidence of a positive effect on pain relief, nor clear evidence that women taking NSAIDs did not require additional (alternative) analgesia.<sup>396</sup> However, a serious limitation of this review was that it included only one trial of 24 women; no additional larger trials have been conducted. As such, NSAIDs continue to be prescribed, but usually in combination with hormonal therapy such as an OC.

## Estrogen-Progestin Contraceptives

Estrogen-progestin contraceptives have been a mainstay of the medical treatment of symptomatic endometriosis almost since their introduction.<sup>397</sup> Even today, they are the most commonly prescribed treatment for the disease. Continuous treatment can eliminate menses and is the preferred method for those with dysmenorrhea. Continuous treatment has been termed "pseudopregnancy" because combined estrogen-progestin therapy

induces amenorrhea and endometrial decidualization and resembles the high progesterone environment of pregnancy widely believed to improve or suppress endometriosis. Although estrogen stimulates the growth of endometriosis, modern OCs are progestin dominant and contain lower doses of estrogen. Limited evidence indicates that estrogen-progestin contraceptives also may enhance apoptosis of eutopic endometrial tissue in women with endometriosis.<sup>398</sup> Overall however, OCs are not considered cytoreductive therapy—once medication is stopped, the ectopic lesions likely resume their cyclic growth and inflammatory activity.<sup>399</sup>

Estrogen-progestin contraceptives are a good initial choice for symptomatic women who also need contraception. They can be expected to provide effective relief from pain associated with endometriosis in up to two-thirds of affected women, particularly when taken continuously.<sup>400,401,402,403,404,405</sup> Through their suppressive actions, they may also help to prevent progression of endometriosis. There is no evidence that any formulation is superior, although one should use only monophasic regimens. One advantage estrogen-progestin contraceptives have over other medical therapies is they can be taken indefinitely. OCs are best used continuously or in a long-cycle regimen, to help minimize pain symptoms related to menses. In long-cycle regimens, active pills are usually taken for at least 90 days continuously, followed by a 7-day pill-free interval, to help prevent breakthrough bleeding and associated pain. Many use these regimens without a pill-free interval for years and stop for 7 days only in response to breakthrough bleeding.

## Progestins

Progestins have long been used to treat symptomatic endometriosis because they inhibit endometrial growth (and presumably the growth of endometriotic tissue), by first inducing decidualization and then atrophy.<sup>406,407</sup> In high doses, they also can inhibit pituitary gonadotropin secretion and ovulation, inducing amenorrhea. A large variety of different progestins are available, including those derived from progesterone-like medroxyprogesterone acetate and others derived from 19-nortestosterone, with norethindrone as the prototype. Suppression of endometrial matrix metalloproteinases (recognized as contributing to the pathogenesis of endometriosis) could be another useful action.<sup>408</sup> Although matrix metalloproteinase activity in eutopic endometrium of women with endometriosis is unusually resistant to progesterone suppression,<sup>409</sup> the higher doses used in the treatment of endometriosis may be sufficient to overcome the effect.

Several different progestins have been used effectively for the treatment of pain (dysmenorrhea, dyspareunia, intermenstrual pain) associated with endometriosis.<sup>410,411,412,413,414</sup> Medroxyprogesterone acetate can be administered orally

(30–100 mg daily) or by injection (150 mg IM every 3 months); however, the breakthrough bleeding associated with the injectable depot form often is accompanied by pain.<sup>415</sup> A single randomized controlled trial demonstrated that high doses of medroxyprogesterone acetate (oral 100 mg daily for 6 months) induced complete remission of all visible endometriosis in 50% of women, compared to 12% of those who received placebo, and incomplete remission in 13%, compared to 6% of placebo-treated controls.<sup>412</sup> Side effects of progestins include nausea, weight gain, fluid retention, breast tenderness, irregular bleeding, and depression. Breakthrough bleeding is common (35–50%) but generally well tolerated and usually can be eliminated by treatment with short courses of supplemental estrogen (conjugated estrogens [CEs] 1.25 mg or estradiol 2.0 mg daily for 7–10 days). Depression is not uncommon (approximately 5%) and can be severe enough to require discontinuation of treatment. Norethindrone acetate (5–15 mg daily) and megestrol acetate (40 mg daily) also have been used in the treatment of endometriosis and have side effects similar to those of medroxyprogesterone acetate.<sup>416,417</sup> The levonorgestrel-releasing intrauterine device is another option that may have particular value for women with deep infiltrating rectovaginal endometriosis,<sup>418,419,420,421,422</sup> with newer studies demonstrating the benefit of reducing pain and dysmenorrhea recurrence following surgical therapy.<sup>423</sup> Limited evidence indicates that the etonogestrel subdermal implant can also be effective for decreased pain associated with endometriosis.<sup>424,425</sup> Dienogest, a fourth-generation progestin, has also been studied as a medical therapy option for endometriosis. Several trials have demonstrated that dienogest is effective in improving endometriosis-associated pain and may even help overcome progesterone resistance by increasing the number of PR.<sup>426,427,428,429</sup> Dienogest is available in Europe, Australia, and Japan, but not in the United States.

Progestins can have adverse effects on serum lipoprotein levels. The 19-nortestosterone–derived progestins decrease HDL significantly; the effects of medroxyprogesterone acetate are less severe.<sup>430,431</sup> However, these effects are unlikely to have any clinical importance over a relatively short interval of months in this low-risk population. At higher doses, the suppressive effects of progestins on the hypothalamic-pituitary-ovarian axis may be sufficient to induce a hypogonadal state, resulting in spinal bone mineral depletion amounting to 2–4% over an interval of 6–12 months; longer-term treatment may result in even greater loss, but recovery usually is rapid after treatment is discontinued and any impact on fracture risk is unlikely.<sup>432</sup>

## **Gonadotropin-Releasing Hormone Analogues**

### **GnRH Agonists**

GnRH agonists are derived from native GnRH by substituting a D-amino acid for the native L-amino acid at position 6 in the decapeptide (**Figure 32.5**). The substitution yields an agonist resistant to degradation, increasing its half-life and time of receptor occupancy. Pituitary follicle-stimulating hormone (FSH) and luteinizing hormone (LH) secretion requires a pulsatile hypothalamic GnRH stimulus, which allows receptor concentrations to be replenished between pulses; a constant intravenous infusion of GnRH generates an initial response (“flare”), followed by down-regulation of receptor concentrations, which desensitizes the pituitary to continued stimulation. Long-acting GnRH agonists (leuprolide, nafarelin, goserelin, buserelin, triptorelin) have the same effect, inducing a hypogonadotropic hypogonadal state that has been dubbed “pseudomenopause” or “medical oophorectomy,” although both terms are misnomers.<sup>433,434</sup> In menopause, the ovaries produce no estrogen because they are depleted of follicles and cannot, and after oophorectomy, the ovaries are altogether absent; in both cases, serum gonadotropin levels are markedly elevated. In contrast, women under treatment with GnRH agonists do not produce estrogen because their ovaries receive no effective gonadotropin stimulation; levels of both FSH and LH are very low. GnRH agonists are effective for the treatment of endometriosis because they induce a hypogonadal state, which deprives existing disease of estrogen support, and amenorrhea, which prevents new peritoneal seeding. Several clinical trials have demonstrated that approximately 85% of women with endometriosis and pelvic pain who are treated with GnRH agonists experience relief of their pain.<sup>435</sup>

GnRH agonists can be administered intramuscularly, subcutaneously, or intranasally, the route varying with the specific drug. Administration of a GnRH agonist 1 week prior to the patient’s menses helps minimize the flare effect. Approximately 75% of women are rendered hypogonadal within 4 weeks of treatment and almost all are by 8 weeks.<sup>436</sup> The side effects of GnRH agonists are those of hypogonadism and include hot flashes, progressive vaginal dryness, decreased libido (both estrogen production and androgen production are suppressed), depression, irritability, fatigue, headache, changes in skin texture, and bone mineral depletion (13% after 6 months of use without add-back).<sup>429</sup> Over 80% report vasomotor symptoms and 30% report vaginal symptoms and headache.<sup>437</sup> GnRH agonist therapy does not have significant adverse effects on serum lipids and lipoprotein concentrations like those associated with danazol or high-dose progestin treatment.<sup>438,439</sup>

In efforts to prevent the bone mineral depletion that accompanies GnRH agonist therapy, a number of different “add-back” treatment strategies have been developed. The “estrogen threshold hypothesis”<sup>440</sup> notes that endometriosis lesions grow when serum estradiol concentration is in the premenopausal range (30–300 pg/mL) and regress when estradiol levels are in the menopausal range (<20 pg/mL). Treatments that



achieve estradiol levels in the range of 20–30 pg/mL are associated with amenorrhea and regression of endometriosis lesions and fewer hypoestrogenic side effects. The add-back regimens are based on the notion that the level of estrogen required to support endometriosis is greater than is required to prevent vasomotor symptoms or bone mineral depletion. Norethindrone can be used alone without additional estrogens as this progestin is unique in having estrogenic metabolites and a well-documented effect on bone density that is distinct from other progestins.<sup>441</sup> Norethindrone acetate 5 mg is the only FDA-approved add-back regimen, although several other estrogen plus progestin combinations exist and can be used in a similar manner to minimize hot flashes and bone loss.<sup>239</sup> Low-dose combined estrogen-progestin add-back regimens (CEs 0.625 mg and medroxyprogesterone acetate 2.5 mg daily or norethindrone 5.0 mg daily)<sup>442,443</sup> Estrogen-only add-back is inadvisable as estradiol promotes lesion growth; a clinical trial (oral estradiol, 1 mg daily) was terminated early due to observations of recurrent pain in treated subjects.<sup>444</sup> **Evidence from randomized trials indicates that hormone add-back regimens protect bone and reduce symptoms of estrogen deficiency without sacrificing control of pain associated with endometriosis.**<sup>436,445,446,447,448,449,450</sup>

Whereas some choose not to begin add-back therapy until pain is under control, this is not recommended as evidence demonstrates that delaying add-back therapy is unnecessary and starting add-back at time of GnRH agonist does not adversely affect pain control.<sup>239,450</sup> Pain of lesser or equal intensity may recur soon after cessation of treatment; the recurrence rate is at least 10–20% per year.<sup>410,451,452,453</sup> The overall cumulative recurrence rate 5 years after treatment with a GnRH agonist is approximately 55%, lower for women with minimal and mild endometriosis (37%) than for those with advanced disease (74%).<sup>454</sup>

In a large uncontrolled trial, leuprolide treatment decreased the volume of endometriosis in almost 90% of women.<sup>455</sup> Numerous other studies comparing a GnRH agonist with danazol have concluded they have equal efficacy<sup>451,456,457,458,459,460</sup> Another comparing a GnRH agonist (leuprolide) to a progestin (lynestrenol) observed a greater decrease in disease in women treated with the GnRH agonist.<sup>461</sup> Treatment with a GnRH agonist can potentially decrease the size of endometriomas, but does not eliminate them.<sup>462</sup> **GnRH agonists are proven effective in relieving pain in women with endometriosis; all agonists appear equally efficacious.**<sup>437,456,463</sup>

## GnRH Antagonist

Elagolix is the first oral nonpeptide GnRH antagonist available for the treatment of endometriosis-associated pain. As opposed to GnRH agonists, antagonists do not

stimulate the receptor, and therefore, there is no flare effect. They directly block the GnRH receptor and therefore can function rapidly, and partial dose-dependent reduction in gonadotropins is readily achieved. Partial reductions of estradiol levels can be used to treat endometriosis without need for add-back, especially at low doses of the GnRH antagonist. In the two completed phase III trials, a low dose (150 mg/day) and high dose (200 mg twice/day) resulted in significant improvement in endometriosis-associated pain, compared to placebo.<sup>464</sup> While both doses were effective, the higher dose had the greatest improvement, especially with respect to dyspareunia. Lastly, the reduction in dysmenorrhea for both doses was greater than the reduction noted for NMPP, which may be due to the fact that dysmenorrhea is typically due to changes in ovarian hormones, while the causes of NMPP are more complex.<sup>464</sup> Elagolix is rapidly bioavailable after initiation of therapy, and suppression of estradiol levels, while dose dependent, occurs within 24 hours.<sup>465</sup> Given the reduction in estradiol levels, hot flushes and other vasomotor symptoms were seen in some subjects; however, these were generally mild and not as severe as typically seen with GnRH agonists. There were more hot flushes (more so in the higher dose group) compared to placebo, but discontinuation due to hot flushes occurred in less than 1% of women using low dose and less than 3% using high dose.<sup>464</sup> Changes in bone mineral density are seen with high-dose therapy requiring limitation to 6 months of therapy or consideration of add-back therapy as with the GnRH agonists.<sup>464</sup> There were also decreases in endometrial thickness and higher amenorrhea rates in women taking elagolix compared to placebo.<sup>464</sup> In the two 6-month extension studies, which followed women in the high- and low-dose groups for an additional 6 months of treatment, vasomotor symptoms and changes in BMD were comparable or less to that seen with GnRH agonists.<sup>466</sup> In addition, after stopping elagolix, BMD returns toward baseline levels.<sup>466</sup> Given their rapid onset, oral administration, absence of flare effect, and the availability of two doses for individual tailoring of therapy, elagolix may be considered the first choice for patients not responding to OCs or those with side effects from progestins. It is important to note that elagolix, at either dose, does not result in complete suppression of ovulation; thus, concomitant contraception is needed in women who are at risk for pregnancy.<sup>465</sup>

## Danazol

Danazol is the first drug ever approved for the treatment of endometriosis in the United States in the 1970s.<sup>467</sup> It is an orally administered isoxazole derivative of 17 $\alpha$ -ethinyltestosterone that acts primarily by inhibiting the midcycle urinary LH surge and inducing a chronic anovulatory state; however, it also inhibits a number of steroidogenic enzymes and increases free testosterone levels (**Figure 32.6**).<sup>468,469,470,471</sup> The many different effects of danazol combine to yield a high-androgen, low-estrogen environment

that inhibits growth of endometriosis. The amenorrhea that commonly results from danazol treatment also likely decreases new peritoneal seeding.<sup>472</sup>

Danazol has proven effective for reducing endometriosis-related pain (dysmenorrhea, deep dyspareunia, intermenstrual pain) in up to 90% of treated women<sup>412,473</sup>; the median time to recurrence of pain after discontinuation of treatment is approximately 6 months.<sup>473</sup> Studies examining the effect of danazol on endometriotic implants (typically assessed after 6 months of treatment) have consistently observed a decrease in the volume of disease ranging between 40% and 90%.<sup>451,456,467,475,476,477</sup> One randomized controlled trial observed regression of disease in 60% of danazol-treated women and in 18% of those who received placebo.<sup>412</sup>

**Although danazol is effective for the treatment of pain associated with endometriosis, the recommended doses (400–800 mg daily) have substantial androgenic and hypoestrogenic side effects that limit its clinical utility.** The most common are weight gain, fluid retention, fatigue, decreased breast size, acne, oily skin, hirsutism, atrophic vaginitis, hot flushes, muscle cramps, and emotional lability. Some can be expected, occurring in up to 80% of women taking danazol, but less than 10% have side effects sufficient to warrant discontinuation of treatment.<sup>478</sup> Danazol crosses the placenta and is a known teratogen; it has been associated with virilization of female fetuses in utero; thus, patients who are taking danazol must use a reliable method of contraception.<sup>479</sup> The androgenic actions of danazol also can deepen the voice irreversibly.<sup>480,481</sup> Adverse changes in the lipid profile reflect the drug's androgenic effects; total cholesterol and low density lipoprotein (LDL) levels are increased and the high density lipoprotein (HDL) concentration is lowered, but these effects pose no significant risk over a relatively short term of treatment. Rarely, danazol treatment may result in liver damage or arterial thrombosis.<sup>478,482</sup> Lower doses of danazol are better tolerated but also possibly less effective.<sup>483,484</sup> Danazol can be administered vaginally, with fewer systemic side effects and up to an 80% improvement in pain symptoms.<sup>485,486,487,488,489,490,491</sup>

## Aromatase Inhibitors

As endometriotic implants produce aromatase, the enzyme required to convert androgens to estrogens, aromatase inhibitors offer another medical approach to management of endometriosis.<sup>18,250,492</sup> Available third-generation aromatase inhibitors include anastrozole and letrozole. While most of the literature on their use comes from breast cancer patients, aromatase inhibitors can block estrogen production in the ovary and endometriotic lesions.<sup>492,493</sup>

Several small studies have used anastrozole (1 mg/day) or letrozole (2.5 mg/day) effectively for the management of endometriosis-associated pain.<sup>250,494,495,496,497,498,499</sup> Given that the reduction in estradiol causes an increase in FSH production and resultant follicular development, **aromatase inhibitors are never a first-line treatment and must be administered with an agent that down-regulates the ovaries in premenopausal women.**<sup>500</sup>

A randomized trial comparing treatment with a GnRH agonist alone to combined treatment with a GnRH agonist and anastrozole in the postoperative management of women receiving surgical treatment for endometriosis found both treatment groups to be effective. However, the addition of anastrozole prolonged the time to symptom recurrence significantly; 14/40 (35%) cases recurred with the GnRH agonist alone, while only 3/40 (7.5%) treated with GnRH agonist plus anastrozole recurred during 24 months of follow-up.<sup>501</sup> Of note, bone loss after 6 months of treatment with GnRH agonist plus anastrozole was significant and persisted even after completion of therapy; none of the women became osteopenic or osteoporotic however. The administration of an aromatase inhibitor plus norethindrone acetate (or norethisterone acetate) has also been found to effectively manage endometriosis-associated pain, including pain related to endometriosis involving the intestines.<sup>495,502,503,504</sup> Aromatase inhibitors with COCs are also effective in relieving pain, with no adverse effects on hematologic, hepatic, renal, lipid, or bone density.<sup>497,503</sup> Aromatase inhibitors have also been used successfully in treating postmenopausal endometriosis, although data are limited to a few case reports.<sup>493,505</sup> The side effects associated with third-generation aromatase inhibitors include headache, joint stiffness, hot flushes (less so compared to GnRH agonists), and leg cramps, but overall aromatase inhibitors seem to be well tolerated.<sup>500</sup>

It is important to note that although studies have demonstrated effectiveness of aromatase inhibitors in treating endometriosis-associated pain, treatment with these agents is still considered investigational, and larger multicenter randomized trials are needed in order to more accurately determine safety/efficacy.<sup>239,493</sup>

## Future Therapeutics

### Hormonal

Recent work has focused on the potential utility of selective progesterone receptor modulators (SPRMs) in the management of endometriosis-associated pain. SPRMs, as their name suggests, can have agonist or antagonist effects on the PR, depending on the tissue target.<sup>506</sup> Mifepristone—the most clinically studied given its use for induction of medical abortions—was found to decrease pain symptoms and induce amenorrhea in

endometriosis patients.<sup>507,508</sup> Additional SPRMs are currently undergoing investigation for treatment of endometriosis-associated pain.

Similarly, selective estrogen receptor modulators (SERMs) may have a role in the treatment of this estrogen-driven disease. Bazedoxifene (BZA; a selective estrogen receptor modulator) alone or paired with a CE in a murine model of endometriosis not only induced regression of endometriotic lesions but also caused degradation of the ER.<sup>509,510</sup> Given that BZA acts as an antiestrogen in the endometrium, these findings are not unexpected. In a case report of BZA-CE use for the management of endometriosis-associated pain, BZA-CE caused complete resolution of pelvic pain, with no adverse effects on the reproductive tract.<sup>511</sup> BZA-CE has also been used successfully as add-back therapy for women using GnRH agonists.<sup>512</sup> While randomized clinical trials are needed to prove efficacy and safety, BZA-CE may represent a novel therapeutic agent for endometriosis-associated pelvic pain, without the unwanted side effects of existing therapies.

Lastly, as endometriosis is a heterogeneous disorder, recent research has focused on an individualized hormonal approach to management of endometriosis-associated pain. In a retrospective study involving women undergoing surgical treatment for endometriosis-associated pain, it was found that PR status (as determined by immunohistochemistry of surgically obtained endometriosis lesions) was strongly associated with response to progestin-based therapy.<sup>513</sup> Women were categorized into three groups based on their PR expression level—high, medium, or low. All women with high PR responded to progestin-based therapy, while only 21% and 6% of women in the medium and low PR group, respectively, responded to progestin-based therapy.<sup>513</sup> While this work requires confirmation in larger prospective trials, it suggests that receptor status in endometriosis could be used in a manner analogous to the use of ER/PR status in breast cancer for tailoring hormonal-based regimens. Such an individualized approach to endometriosis management would negate trialing progestin-based therapy to determine progesterone resistance.

## **Nonhormonal and Investigational**

All of the regimens above use hormonal manipulation to suppress endometrial growth and alter menstrual cyclicality. Future therapies should be more disease specific and target endometriosis without altering reproductive hormone production or fertility. Immune conjugate (ICON) targets tissue factor that is aberrantly expressed in mouse endometriotic lesions, which causes regression of disease, likely through devascularization.<sup>514</sup> Several antiangiogenic agents such as statins, COX-2 inhibitors, dopamine agonists, and peroxisome proliferative-activated receptor agonists are undergoing evaluation in animal models and in vitro; however, clinical evidence is not

yet available.<sup>506,515</sup> There is also research underway aimed at targeting and correcting the altered molecular pathways in patients with endometriosis, such as aberrant miRNA expression and aberrant methylation patterns.<sup>516</sup> Lastly, therapy to block mesenchymal stem cell recruitment to ectopic endometrium is also under investigation.<sup>96,97</sup>

## Key Points

- **Established medical therapies for the treatment of pain associated with endometriosis include estrogen-progestin contraceptives, progestins, GnRH analogues, and danazol.**
- **Typically, OCs are the first line of therapy with GnRH antagonists becoming the optimal second-line therapy in those who fail OC treatment or have troubling progestin-related side effects.**
- **Treatment decisions must be individualized, after carefully considering the severity of symptoms, the extent of disease, the desire for future pregnancy, age, side effects, and costs.**
- **Research is ongoing for the development of new therapeutic agents.**

# Surgical Treatment

**The objectives of surgical treatment for endometriosis are to restore normal anatomical relationships, remove all visible and deep disease to the extent possible, and prevent adhesions.**

Laparoscopy is considered the standard surgical approach. Compared to laparotomy, laparoscopy offers the advantages of better visualization, less tissue trauma and desiccation, smaller incisions, and a speedier postoperative recovery.<sup>517</sup> Postoperative adhesions and complications also may be less than after laparotomy.<sup>517</sup> Most importantly, the results achieved with laparoscopy are equivalent to or better than laparotomy.<sup>519</sup> In cases of severe endometriosis with extensive adhesive disease, however, surgical approach is surgeon dependent.

## Conservative Surgery

Peritoneal implants of endometriosis may be ablated with bipolar electro-surgical instruments or excised by sharp dissection.<sup>520</sup> A Cochrane review including seven randomized controlled trials compared different laparoscopic surgical methods (including excisional vs. ablative techniques) with diagnostic laparoscopy and found that pain improved with operative laparoscopy compared to diagnostic laparoscopy alone—by 100%, 70%, and 40% in women with moderate, mild, and minimal endometriosis, respectively.<sup>521</sup> In comparing excision versus ablation for surgical management of endometriosis, there was no clear superiority of one method over another.<sup>521</sup> However, those favoring excision over ablation emphasize that because the depths of disease and ablation cannot be determined, the risk that treatment may be inadequate is greater when disease is ablated rather than excised. Furthermore, excisional surgery allows for a histologic diagnosis. Strict adherence to the same microsurgical principles that governed reconstructive pelvic surgery before the advent of modern laparoscopic techniques improves operative outcomes—use of magnification, minimum tissue trauma and exposed suture, and meticulous hemostasis.

The optimal surgical approach to managing deep infiltrating endometriosis (DIE) requires careful preoperative planning and discussion with the patient.<sup>521</sup> DIE, defined as endometriosis that penetrates greater than 5 mm under the peritoneal surface, includes rectovaginal lesions, as well lesions involving the bowel (3–37%), urinary tract (52%), and uterosacral ligaments (60–90%).<sup>523,524,525</sup> These infiltrating lesions are a significant cause of pelvic pain. Given that surgery in these locations requires careful surgical technique, patients with DIE should be referred to tertiary care centers not only to help minimize intraoperative complications but also to avoid incomplete surgery and need

for repeat surgery; often, a multidisciplinary surgical team is needed.<sup>522,525</sup> In experienced hands, surgical excision of the disease generally achieves excellent results. Over 3 years, postoperative recurrence rates for dysmenorrhea, deep dyspareunia, and pelvic pain range from 15% to 30% and are lowest when any involved vaginal or rectal lesion is also removed.<sup>526</sup>

Endometriomas should be excised if they cause pain and/or become enlarged and risk torsion; excision is also an option in patients with infertility. Two randomized clinical trials have shown that excision (compared to drainage or ablation) results in overall greater pain relief, lower recurrence of endometriosis-associated pain, and lower recurrence of endometrioma formation.<sup>527</sup> A 2008 systematic review concluded that laparoscopic excision of the cyst wall was associated with a lower rate of recurrence of the endometrioma (OR = 0.41, CI = 0.18–0.93); a decreased requirement for further surgery (OR = 0.21, CI = 0.05–0.79); reduced recurrence of dysmenorrhea (OR = 0.15, CI = 0.06–0.38), dyspareunia (OR = 0.08, CI = 0.01–0.51), and NMPP (OR = 0.10, CI = 0.02–0.56), and an increased pregnancy rate in women who previously were infertile (OR = 5.21, CI = 2.04–13.29).<sup>527,528</sup> Careful surgical technique is important because ovarian function can be compromised by excision of excessive tissue or damage to hilar vessels, as demonstrated by postoperative AMH levels.<sup>529,530</sup> Regardless of surgical procedure (i.e., complete excision vs. combination of excision and ablation), AMH levels can be adversely affected; however, it does not appear to impair ovarian response/fertility.<sup>527</sup> The risk of ovarian failure after excision of bilateral ovarian endometriomas is approximately 2.5%.<sup>531</sup> Lastly, even in the setting of asymptomatic greater than 4 cm endometriomas, removal may be recommended given the association of endometriomas with endometrioid and clear cell cancer of the ovary.<sup>14,522</sup>

Adjuvant presacral neurectomy (PSN) and laparoscopic uterosacral nerve ablation (LUNA) have been advocated for the management of dysmenorrhea and severe central pelvic pain unresponsive to medical or previous surgical treatment for endometriosis. PSN involves interrupting the sympathetic innervation of the uterus at the level of the superior hypogastric plexus, and LUNA involves the destruction of the midportion of the uterosacral ligaments. While PSN may be considered for women with central pelvic pain desiring conservative surgery, LUNA is no longer recommended as it has not resulted in compelling evidence of pain improvement.<sup>532</sup> Operative complications and postoperative bowel or bladder dysfunction, although uncommon, do occur and can be debilitating.<sup>533,534</sup> PSN should be reserved for highly selected individuals, who must be counseled very carefully.

**Unfortunately, as with medical treatment, recurrent disease and pain after local excision or ablation of endometriosis are common; the cumulative probability**



of recurrence is between 40% and 45% at 5-year follow-up, while the probability of requiring repeat surgery is 15–25% by 2 years and 45–55% by 5–7 years.<sup>535,536,537,538</sup> A study involving second-look laparoscopy after surgical treatment of minimal or mild endometriosis found that disease most often recurs in the same or adjacent areas of the pelvis, suggesting either incomplete excision during the initial surgery or favored implantation in certain locations.<sup>539</sup> The incidence of recurrent disease may be higher after surgical treatment in the luteal phase than in the follicular phase because refluxed endometrial cells may be more likely to implant at sites of unhealed peritoneal trauma when the interval from surgery to next menstruation is short.<sup>540</sup> In addition, despite meticulous surgical technique, surgery itself can result in pelvic adhesions, which can become a primary cause of continued pelvic pain.

## Definitive Surgery

In women with advanced, symptomatic endometriosis who have completed childbearing and those in whom medical and conservative surgical treatment fails, definitive surgical treatment deserves consideration. In highly selected women having no significant ovarian disease, hysterectomy alone can be considered, although the risk of recurrent disease requiring additional treatment is approximately sixfolds higher when oophorectomy is not performed, as the estrogen produced by the ovary(ies) stimulates endometriotic lesion growth.<sup>541</sup> In women undergoing hysterectomy and bilateral salpingo-oophorectomy (BSO), 90% of women experience long-term relief.<sup>239</sup> A risk factor for persistent or recurrent endometriosis and pain is incomplete excision of disease in women with extensive or residual disease.<sup>541,542</sup> **While no prospective study has demonstrated that estrogen therapy alone causes recurrence of disease, given that endometriosis is an estrogen-dependent disorder, endometriosis represents a condition where even after hysterectomy estrogen plus progestin therapy should be administered for menopausal hormone therapy.**<sup>542,543</sup> Lastly, in those with persistent pain following hysterectomy with BSO, consideration of possible ovarian remnant syndrome is warranted. Ovarian remnant syndrome involves persistent or recurrent disease and pain associated with residual functional ovarian tissue. The syndrome is not altogether rare and occurs most frequently when the ovaries are enlarged or densely adherent to the pelvic sidewalls and dissection is technically difficult.<sup>544,545,546</sup> Ovarian remnant syndrome is suspected when serum levels of FSH are less than 30 IU/dL and estradiol levels are greater than 20 pg/mL.<sup>547</sup> In postmenopausal women, serum measurements are less helpful, and even in premenopausal women, values may fluctuate. Thus, adjunct tests include transvaginal ultrasound and/or MRI for

visualization of a pelvic mass.<sup>547</sup> Ultimately, surgical evaluation and tissue biopsy are needed for confirmation and treatment.<sup>547</sup>

## Postoperative Medical Therapy

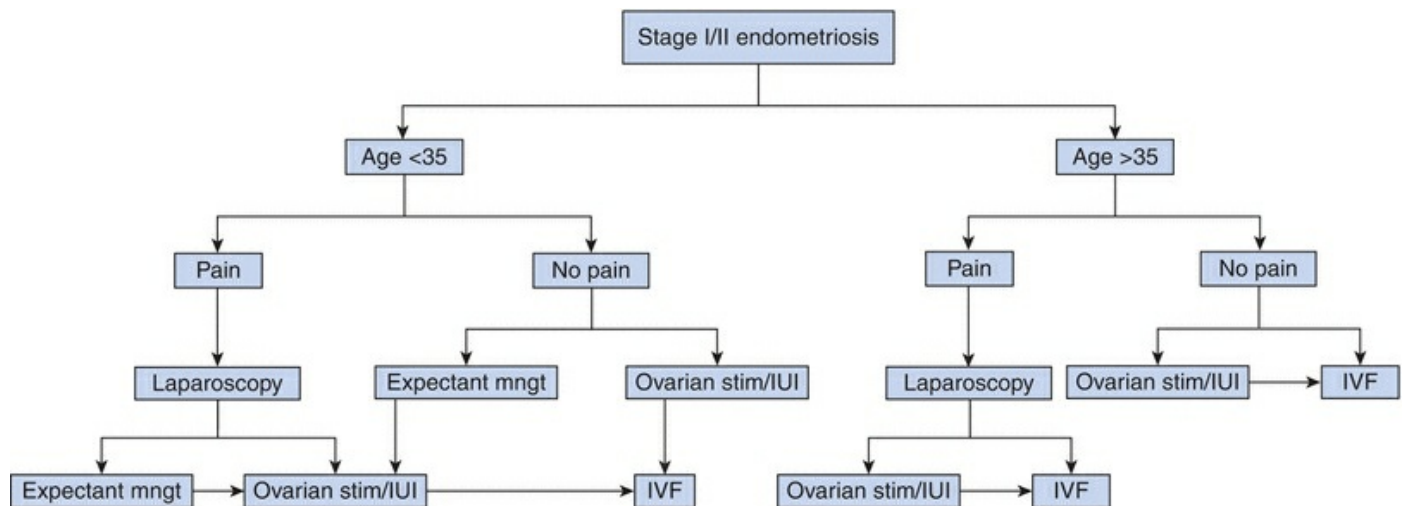
Similar to what can occur in cancer, recurrence of endometriosis can be due to regrowth of residual or microscopic endometriotic lesions. Alternatively, recurrence may be due to de novo lesion formation. Regardless of the cause, given the known risk of recurrence following conservative surgery for endometriosis, studies have addressed the potential benefit of medical treatment following surgery. Initial studies did not appear to demonstrate effectiveness of postsurgical hormonal-suppressive therapy; however, these studies discontinued medication after 3 or 6 months.<sup>548</sup> As previously noted, existing therapies simply suppress endometriosis; they are not cytoreductive. Thus, once treatment stops, lesions can resume growth. As such, recent work has focused on tertiary prevention. In a meta-analysis of 15 studies of long-term hormonal therapy following surgical management, there were lower recurrence rates of dysmenorrhea and endometrioma(s).<sup>548,549</sup> While additional studies are needed in order to determine the most effective postsurgical hormonal therapy for a given patient, this data is promising, and as such, we routinely recommended postsurgical hormonal therapy in an attempt to prevent recurrence of disease/pain. **An exception to postsurgical hormonal therapy however is in women who are attempting to conceive immediately following surgery; but in women who wish to delay conception, suppressive hormonal therapy is still encouraged.**

## Multimodal Approach

In some women, medical therapy and surgery are not sufficient for effectively eliminating endometriosis-related symptoms. For those with complex pelvic pain syndromes, a multidisciplinary approach including psychological counseling, pelvic floor physical therapy, acupuncture, transcutaneous electrical nerve stimulators, implantable nerve stimulators, and/or trigger point injections with anesthetic agents may be beneficial.<sup>548</sup> Lastly, while no large clinical trials have evaluated the use of complimentary therapies to treat endometriosis-associated pelvic pain, women with endometriosis have reported that nutritional and exercise programs help alleviate pain symptoms. Nutritional interventions such as avoiding red meat, as well as transsaturated and saturated fats, have been reported to reduce pain symptoms, as have structured exercise programs. Chinese herbal medication has also been effective in clinical trials.<sup>550</sup>

# TREATMENT OF ENDOMETRIOSIS-ASSOCIATED INFERTILITY

There are several treatment options available to women with endometriosis who are seeking fertility. While not routinely recommended, expectant management is an option for women who are hesitant to pursue ovarian stimulation with or without intrauterine insemination (IUI) or IVF. As mentioned earlier, the fecundity rate of women with endometriosis is lower than in the noninfertile reproductive population; however, women with endometriosis can conceive without intervention. As the overall likelihood of success with expectant management is less, it should only be considered in women who do not have advance-stage disease and who are less than 35 years of age (Figure 32.7).



Reprinted from **Kodaman PH**. Current strategies for endometriosis management. *Obstet Gynecol Clin North Am* 42(1):87, 2015, with permission from Elsevier.<sup>522</sup>

Medications used to treat endometriosis-associated pain are predominantly hormonal and suppress ovulation. In a Cochrane review of 25 trials using ovulation suppressive agents (COCs, progestins, danazol, GnRH agonists) in an effort to improve fertility in women with endometriosis, there was no benefit to use of ovulation suppression.<sup>550</sup> Use of ovulation suppression agents increased time to conceive. The one exception is the use of GnRH agonists or COCs for suppression of endometriosis in patients undergoing IVF. A Cochrane review of three randomized controlled trials using a GnRH agonist for 3–6 months prior to IVF found that both the clinical pregnancy and live birth rates were significantly higher in the GnRH agonist group compared to the control group.<sup>552,553</sup> In a pilot trial assessing effect of 6–8 weeks of COC use prior to IVF in women with

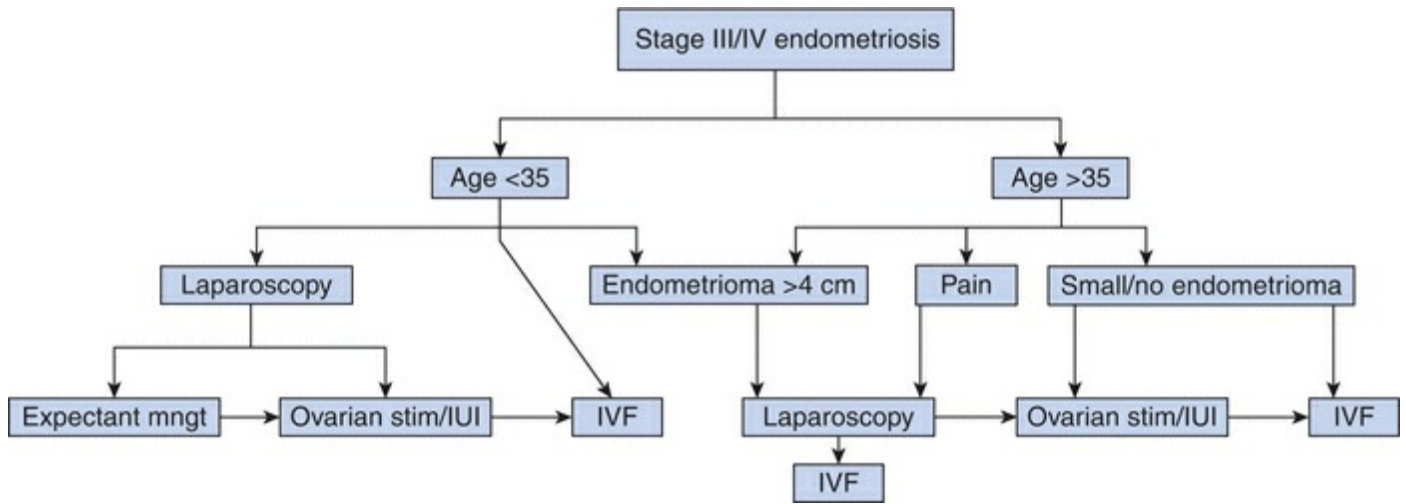
endometriosis, it was found that COC use significantly increased the odds of pregnancy.<sup>554</sup> Furthermore, COC use may be as effective as GnRH agonist, although larger randomized trials are needed to confirm this.<sup>554</sup>

# Surgical Treatment

The effects of surgery on fertility in women with minimal and mild endometriosis have been examined in two randomized controlled trials. In a multicenter Canadian trial, women with unexplained infertility had diagnostic laparoscopy, and those with minimal or mild endometriosis were randomized to treatment (excision or ablation of disease) or expectant management and followed for 36 weeks or until 20 weeks of gestation if pregnancy occurred during follow-up.<sup>260</sup> The chance of pregnancy in treated women was twice that in untreated women (OR = 2.03, CI = 1.28–3.24). Overall, 50/172 (0.29) women randomized to treatment achieved an ongoing pregnancy, compared to 29/169 (0.17) of those managed expectantly, yielding a treatment effect of 0.12 and a number needed to treat (the inverse of the treatment effect) of 8.3, rounded upward to 9. **The results suggest that approximately nine infertile women with minimal or mild endometriosis must undergo surgical treatment to achieve one additional pregnancy.** However, in a second smaller Italian trial of similar design (n = 96), no difference between treatment and no treatment was observed.<sup>555</sup> A meta-analysis combining the data from both studies concluded that surgical treatment of minimal and mild endometriosis may improve fertility (OR = 1.64, CI = 1.05–2.57); the number needed to treat was 12.<sup>261</sup> In women with mild to moderate disease, surgical treatment with removal of endometrial implants has the potential benefit of decreasing inflammation, which may improve fertility (**Figure 32.7**). For women with endometriomas, the literature is clear—the cumulative pregnancy rate 1–3 years after surgical treatment is approximately 50% for women with endometriomas, and response to gonadotropins is also improved.<sup>519,556,557,558,559</sup>

In severe disease, potential benefits of surgery include lysis of adhesions and ideally resultant restoration of normal pelvic anatomy; two randomized controlled trials demonstrated that laparoscopy was beneficial for advance-stage disease.<sup>560,561</sup> In addition, for women who are in pain and attempting to conceive, surgical intervention should be an option prior to proceeding with ovarian stimulation/IUI or IVF, as available regimens can exacerbate pain (**Figure 32.8**). In a prospective cohort study involving 169 infertile women under age 38 with symptomatic deep infiltrating endometriosis, the pregnancy rate achieved with IVF was significantly higher in women who chose to have preliminary surgical treatment.<sup>562</sup> Although the advantages of surgical treatment in infertile women with severe endometriosis seem obvious, there are few randomized controlled trials assessing the potential benefits, and more research is needed. The use of adhesion barriers reduces adhesion formation after surgical treatment in infertile women,<sup>563</sup> but there is no convincing evidence that adhesion barriers or other adhesion prevention strategies improve pregnancy rates after surgical

treatment. <sup>563,564</sup>



Reprinted from **Kodaman PH**. Current strategies for endometriosis management. *Obstet Gynecol Clin North Am* 42(1):87, 2015, with permission from Elsevier. <sup>522</sup>

# Ovarian Stimulation and Assisted Reproductive Technology

In patients with minimal to mild endometriosis with patent tubes, ovarian stimulation (with clomiphene citrate, letrozole, or gonadotropins) with or without intrauterine insemination can be tried, as fertility rates are increased.<sup>14</sup> This method is preferred when the patient does not have distorted anatomy; however, no more than four cycles are recommended, as each can stimulate endometriotic lesions (**Figure 32.7**). As mentioned earlier, IVF success rates in women with endometriosis are similar to those with tubal and male factor and unexplained. It still remains unclear how much endometriosis affects pregnancy rates when compared to other causes of infertility; **however, in vitro fertilization is currently the most effective treatment of endometriosis-associated infertility, especially in women with advanced disease (Figure 32.8).**

# ENDOMETRIOSIS AS A SYSTEMIC DISORDER

---

While emphasis is placed on endometriosis as a gynecologic/pelvic disorder, it is important to recognize that endometriosis is a systemic disorder, with effects on the brain, metabolic and inflammatory processes, and sexual health.<sup>565</sup> In addition to altered pain sensitization, women with endometriosis have an increased incidence of anxiety and depression.<sup>248</sup> This is likely related to endometriosis modulating gene expression in regions of the brain controlling emotional and behavioral changes.<sup>248</sup> Similarly, and as previously mentioned, women with endometriosis have a lower BMI than women without endometriosis. This finding may be related to endometriosis' effect on hepatic gene expression.<sup>566</sup> A low BMI in a murine model of endometriosis was found to be due to altered expression of genes in the liver that regulate metabolic pathways.<sup>566</sup> Endometriosis is also considered a proinflammatory condition. As discussed earlier in the chapter, differential expression of miRNAs can influence cytokine expression of macrophages, thereby further promoting an increase in inflammation.<sup>128</sup> As miRNAs are stable, and can circulate in the bloodstream, this provides further support for the ability of endometriosis to have systemic effects distant from sites of ectopic endometrium in the pelvis. Furthermore, an increased inflammatory response can increase the risk of cardiovascular disease and cancer.<sup>567,568</sup> Lastly, while studies following therapeutic intervention assess pain symptoms, few have assessed their effect on sexual function, which depends not only on the symptom of dyspareunia but also on physical and mental comorbidities.<sup>568</sup> The effects of endometriosis are not isolated to the lesions in the pelvis. Although current medical and surgical methods will effectively treat local disease, it is imperative to identify appropriate therapies that will also target the systemic aspects of this disease, in an effort to improve the overall health and well-being of women suffering from this chronic, debilitating disease.



# REFERENCES

1. **Knapp VJ**, How old is endometriosis? Late 17th- and 18th-century European descriptions of the disease, *Fertil Steril* 72(1):10, 1999.
2. **Nezhat C, Nezhat F**, Endometriosis: ancient disease, ancient treatments, *Fertil Steril* 98(6 Suppl):S1, 2012.
3. **Sampson JA**, Perforating hemorrhagic cysts (chocolate cyst) of the ovary: their importance and especially their relation to pelvic adenomas of the endometrial type, *Arch Surg* 3:245, 1921.
4. **Macer ML, Taylor HS**, Endometriosis and infertility: a review of the pathogenesis and treatment of endometriosis-associated infertility, *Obstet Gynecol Clin North Am* 39(4):535, 2012.
5. **Bulun SE**, Endometriosis, *N Engl J Med* 360(3):268, 2009.
6. **Nnoaham KE, Hummelshoj L, Webster P, d'Hooghe T, de Cicco Nardone F, de Cicco Nardone C**, et al., Impact of endometriosis on quality of life and work productivity: a multicenter study across ten countries, *Fertil Steril* 96(2):366, 2011.
7. **Simoens S, Dunselman G, Dirksen C, Hummelshoj L, Bokor A, Brandes I**, et al., The burden of endometriosis: costs and quality of life of women with endometriosis and treated in referral centres, *Hum Reprod* 27(5):1292, 2012.
8. **Wheeler JM**, Epidemiology of endometriosis-associated infertility, *J Reprod Med* 34:41, 1989.
9. **Strathy JH, Molgaard CA, Coulam CB, Melton LJ III**, Endometriosis and infertility: a laparoscopic study of endometriosis among fertile and infertile women, *Fertil Steril* 38:667, 1982.
10. **Chatman DL, Ward AB**, Endometriosis in adolescents, *J Reprod Med* 27:156, 1982.
11. **Goldstein DP, deCholnoky C, Emans SJ, Leventhal JM**, Laparoscopy in the diagnosis and management of pelvic pain in adolescents, *J Reprod Med* 24:251, 1989.
12. **Mahmood TA, Templeton A**, Prevalence and genesis of endometriosis, *Hum Reprod* 6:544, 1991.
13. **Sangi-Haghpeykar H, Poindexter AN III**, Epidemiology of endometriosis among parous women, *Obstet Gynecol* 85:983, 1995.
14. **Giudice LC**, Clinical practice. Endometriosis, *N Engl J Med* 362(25):2389, 2010.
15. **Cramer DW, Missmer SA**, The epidemiology of endometriosis, *Ann N Y Acad Sci* 955:11, 2002.
16. **D'Hooghe TM, Debrock S, Hill JA, Meuleman C**, Endometriosis and subfertility: is the relationship resolved? *Semin Reprod Med* 21:243, 2003.
17. **Giudice LC, Kao LC**, Endometriosis, *Lancet* 364:1789, 2004.
18. **Bulun SE**, Endometriosis, *New Engl J Med* 360:268, 2009.
19. **Kuohung W, Jones GL, Vitonis AF, Cramer DW, Kennedy SH, Thomas D, Hornstein MD**, Characteristics of patients with endometriosis in the United States and the United Kingdom, *Fertil Steril* 78:767, 2002.
20. **Hediger ML, Hartnett HJ, Louis GM**, Association of endometriosis with body size and figure, *Fertil Steril* 84:1366, 2005.
21. **Reese KA, Reddy S, Rock JA**, Endometriosis in an adolescent population: the emory experience, *J Pediatr Adolesc Gynecol* 9:125, 1996.
22. **Janssen EB, Rijkers AC, Hoppenbrouwers K, Meuleman C, D'Hooghe TM**, Prevalence of endometriosis diagnosed by laparoscopy in adolescents with dysmenorrhea or chronic pelvic pain: a systematic review, *Hum Reprod Update* 19(5):570, 2013.
23. **Huffman JW**, Endometriosis in young teen-age girls, *Pediatr Ann* 10:501, 1981.
24. **Punnonen R, Klemi PJ, Nikkanen V**, Postmenopausal endometriosis, *Eur J Obstet Gynecol Reprod Biol* 11:195, 1980.
25. **Djursing H, Petersen K, Weberg E**, Symptomatic postmenopausal endometriosis, *Acta Obstet Gynecol Scand* 60:529, 1981.
26. **Tan DA, Almaria MJG**, Postmenopausal endometriosis: drawing a clearer clinical picture, *Climacteric* 21(3):249, 2018.
27. **Missmer SA, Hankinson SE, Spiegelman D, Barbieri RL, Marshall LM, Hunter DJ**, Incidence of

- laparoscopically confirmed endometriosis by demographic, anthropometric, and lifestyle factors, *Am J Epidemiol* 160:784, 2004.
28. **Berube S, Marcoux S, Maheux R**, Characteristics related to the prevalence of minimal or mild endometriosis in infertile women. Canadian Collaborative Group on Endometriosis, *Epidemiology* 9:504, 1998.
  29. **Shah DK, Correia KF, Vitonis AF, Missmer SA**, Body size and endometriosis: results from 20 years of follow-up within the Nurses' Health Study II prospective cohort, *Hum Reprod* 28:1783, 2013.
  30. **Vitonis AF, Baer HJ, Hankinson SE, Laufer MR, Missmer SA**, A prospective study of body size during childhood and early adulthood and the incidence of endometriosis, *Hum Reprod* 25:1325, 2010.
  31. **Ferrero S, Anserini P, Remorgida V, Ragni N**, Body mass index in endometriosis, *Eur J Obstet Gynecol Reprod Biol* 121:94, 2005.
  32. **Shafir AL, Farland LV, Shah DK, Harris HR, Kvaskoff M, Zondervan K**, et al., Risk for and consequences of endometriosis: a critical epidemiologic review, *Best Pract Res Clin Obstet Gynaecol* 51:1, 2018.
  33. **Darrow SL, Vena JE, Batt RE, Zielezny MA, Michalek AM, Selman S**, Menstrual cycle characteristics and the risk of endometriosis, *Epidemiology* 4:135, 1993.
  34. **Matorras R, Rodriquez F, Pijoan JI, Ramon O, Gutierrez de Teran G, Rodriguez-Escudero T**, Epidemiology of endometriosis in infertile women, *Fertil Steril* 63:34, 1995.
  35. **Gruppos Italiano per lo Studio Dell'Endometriosi**, Risk factors for pelvic endometriosis in women with pelvic pain or infertility, *Eur J Obstet Gynecol Reprod Biol* 83:195, 1999.
  36. **Moen MH**, Is a long period without childbirth a risk factor for developing endometriosis? *Hum Reprod* 6:1404, 1991.
  37. **Zhou Y, Jorgensen EM, Gan Y, Taylor HS**, Cigarette smoke increases progesterone receptor and homeobox A10 expression in human endometrium and endometrial cells: a potential role in the decreased prevalence of endometrial pathology in smokers, *Biol Reprod* 84(6):1242, 2011.
  38. **Rier S, Foster WG**, Environmental dioxins and endometriosis, *Semin Reprod Med* 21:145, 2003.
  39. **Bruner-Tran KL, Osteen KG**, Dioxin-like PCBs and endometriosis, *Syst Biol Reprod Med* 56(2):132, 2010.
  40. **Missmer SA, Hankinson SE, Spiegelman D, Barbieri RL, Michels KB, Hunter DJ**, In utero exposures and the incidence of endometriosis, *Fertil Steril* 82:1501, 2004.
  41. **Giudice LC, Swiersz LM, Burney RO**, Endometriosis. In: Jameson JL, De Groot LJ, eds. *Endocrinology*, 6th ed, Elsevier, New York, 2010, p. 2356.
  42. **Somigliana E, Viganò P, Parazzini F**, et al., Association between endometriosis and cancer: a comprehensive review and a critical analysis of clinical and epidemiological evidence, *Gynecol Oncol* 101:331, 2006.
  43. **Sampson JA**, Peritoneal endometriosis due to the menstrual dissemination of endometrial tissue into the peritoneal cavity, *Am J Obstet Gynecol* 14:422, 1927.
  44. **Olive DL, Henderson DY**, Endometriosis and müllerian anomalies, *Obstet Gynecol* 69:412, 1987.
  45. **Burney RO, Giudice LC**, Pathogenesis and pathophysiology of endometriosis, *Fertil Steril* 98(3):511, 2012.
  46. **Liu DTY, Hitchcock A**, Endometriosis: its association with retrograde menstruation, dysmenorrhea, and tubal pathology, *Br J Obstet Gynaecol* 93:859, 1986.
  47. **Kruitwagen RFPM, Poels LG, Willemsen WNP, Jap PHK, Thomas CMG, Rolland R**, Endometrial epithelial cells in peritoneal fluid during the early follicular phase, *Fertil Steril* 55:297, 1991.
  48. **Witz CA, Monotoya-Rodriguez IA, Schenken RS**, Whole explants of peritoneum and endometrium: a novel model of the early endometriosis lesion, *Fertil Steril* 71:56, 1999.
  49. **Maas JW, Groothuis PG, Dunselman GA, de Goeij AF, Struijker-Boudier HA, Evers JL**, Development of endometriosis-like lesions after transplantation of human endometrial fragments onto the chick embryo chorioallantoic membrane, *Hum Reprod* 16:627, 2001.
  50. **Cramer DW, Wilson E, Stillman RJ, Berger MJ, Belisle S, Schiff I, Albrecht B, Gibson M, Stadel BV, Schoenbaum SC**, The relation of endometriosis to menstrual characteristics, smoking and exercise, *JAMA* 355:1904, 1986.
  51. **Jenkins S, Olive DL, Haney AF**, Endometriosis: pathogenetic implications of the anatomic distribution, *Obstet Gynecol* 67:335, 1986.

52. **Ishimura T, Masuzaki H**, Peritoneal endometriosis: endometrial tissue implantation as its primary etiologic mechanism, *Am J Obstet Gynecol* 165:210, 1991.
53. **Gruppos Italiano per lo Studio Dell'Endometriosi**, Prevalence and anatomical distribution of endometriosis in women with selected gynaecological conditions: results from a multicentric Italian study, *Hum Reprod* 9:1158, 1994.
54. **TeLinde R, Scott R**, Experimental endometriosis, *Am J Obstet Gynecol* 60:1147, 1950.
55. **Scott RB, TeLinde RW, Wharton LR Jr**, Further studies on experimental endometriosis, *Am J Obstet Gynecol* 66:1082, 1953.
56. **Lee B, Du H, Taylor HS**, Experimental murine endometriosis induces DNA methylation and altered gene expression in eutopic endometrium, *Biol Reprod* 80(1):79, 2009.
57. **Taylor HS, Alderman Iii M, D'Hooghe TM, Fazleabas AT, Duleba AJ**, Effect of simvastatin on baboon endometriosis, *Biol Reprod* 97(1):32, 2017.
58. **D'Hooghe TM, Bambra CS, Raeymaekers BM, De Jonge I, Lauweryns JM, Koninckx PR**, Intrapelvic injection of menstrual endometrium causes endometriosis in baboons (*Papio cynocephalus* and *Papio anubis*), *Am J Obstet Gynecol* 173:125, 1995.
59. **Ridley J, Edwards I**, Experimental endometriosis in the human, *Am J Obstet Gynecol* 76:783, 1958.
60. **Ferguson BR, Bennington JL, Haber SL**, Histochemistry of mucosubstances and histology of mixed mullerian pelvic lymph node glandular inclusions. Evidence for histogenesis by mullerian metaplasia of coelomic epithelium, *Obstet Gynecol* 33(5):617, 1969.
61. **Suginami H**, A reappraisal of the coelomic metaplasia theory by reviewing endometriosis occurring in unusual sites and instances, *Am J Obstet Gynecol* 165:214, 1991.
62. **Clark AH**, Endometriosis in a young girl, *JAMA* 136:690, 1948.
63. **Whitehouse HB**, Endometrioma invading the bladder removed from a patient who never menstruated, *Proc R Soc Med* 19:15, 1925.
64. **El-Mahgoub S, Yaseen S**, A positive proof for the theory of coelomic metaplasia, *Am J Obstet Gynecol* 137:137, 1980.
65. **Schifrin BS, Erez S, Moore JG**, Teen-age endometriosis, *Am J Obstet Gynecol* 116:973, 1973.
66. **Foster DC, Stern JL, Buscema J, Rock JA, Woodruff JD**, Pleural and parenchymal pulmonary endometriosis, *Obstet Gynecol* 58:552, 1981.
67. **Gruenwald P**, Origin of endometriosis from the mesenchyme of the coelomic walls, *Am J Obstet Gynecol* 44:470, 1942.
68. **Fujii S**, Secondary mullerian system and endometriosis, *Am J Obstet Gynecol* 165:219, 1991.
69. **Das Gupta S, Pal SK, Saha PK, Dawn CS**, Endometriosis in the thumb, *J Indian Med Assoc* 83:122, 1985.
70. **Gitelis S, Petasnick JP, Turner DA, Ghiselli RW, Miller AW III**, Endometriosis simulating a soft tissue tumor of the thigh: CT and MR evaluation, *J Comput Assist Tomogr* 9:573, 1985.
71. **Patel VC, Samuels H, Abeles E, Hirjibehedin PF**, Endometriosis at the knee. A case report, *Clin Orthop* 171:140, 1982.
72. **Oliker AJ, Harris AE**, Endometriosis of the bladder in a male patient, *J Urol* 106:858, 1971.
73. **Schrodt GR, Alcorn MO, Ibanez J**, Endometriosis of the male urinary system: a case report, *J Urol* 124:722, 1980.
74. **Martin JD Jr, Hauck AE**, Endometriosis in the male, *Am Surg* 51:426, 1985.
75. **Matsuura K, Ohtake H, Katabuchi H, Okamura H**, Coelomic metaplasia theory of endometriosis: evidence from in vivo studies and an in vitro experimental model, *Gynecol Obstet Invest* 47(Suppl 1):18, 1999.
76. **Redwine DB**, Was Sampson wrong?, *Fertil Steril* 78:686, 2002.
77. **Comiter CV**, Endometriosis of the urinary tract, *Urol Clin North Am* 29:625, 2002.
78. **Shah M, Tager D, Feller E**, Intestinal endometriosis masquerading as common digestive disorders, *Arch Intern Med* 155:977, 1995.
79. **Candiani GB, Vercellini P, Fedele L, Vendola N, Carinelli S, Scaglione V**, Inguinal endometriosis: pathogenetic and clinical implications, *Obstet Gynecol* 78:191, 1991.
80. **Zollner U, Girschick G, Steck T, Dietl J**, Umbilical endometriosis without previous pelvic surgery: a case

report, *Arch Gynecol Obstet* 267:258, 2003.

81. **Markham SM, Carpenter SE, Rock JA**, Extrapelvic endometriosis, *Obstet Gynecol Clin North Am* 16:193, 1989.
82. **Honore GM**, Extrapelvic endometriosis, *Clin Obstet Gynecol* 42:699, 1999.
83. **Javert CT**, Pathogenesis of endometriosis based on endometrial homeoplasia, direct extension, exfoliation and implantation, lymphatic and hematogenous metastasis. Including five case reports of endometrial tissue in pelvic lymph nodes, *Cancer* 2:399, 1949.
84. **Ueki M**, Histologic study of endometriosis and examination of lymphatic drainage in and from the uterus, *Am J Obstet Gynecol* 165:201, 1991.
85. **Ichimiya M, Hirota T, Muto M**, Intralymphatic embolic cells with cutaneous endometriosis in the umbilicus, *J Dermatol* 25:333, 1998.
86. **Moore JG, Binstock MA, Growdon WA**, The clinical implications of retroperitoneal endometriosis, *Am J Obstet Gynecol* 158:1291, 1988.
87. **Scholefield HJ, Sajjad Y, Morgan PR**, Cutaneous endometriosis and its association with caesarean section and gynaecological procedures, *J Obstet Gynaecol* 22:553, 2002.
88. **Taff L, Jones S**, Cesarean scar endometriosis. A report of two cases, *J Reprod Med* 47:50, 2002.
89. **Kanellos I, Kelpis T, Zaraboukas T, Betsis D**, Perineal endometriosis in episiotomy scar with anal sphincter involvement, *Tech Coloproctol* 5:107, 2001.
90. **Sasson IE, Taylor HS**, Stem cells and the pathogenesis of endometriosis, *Ann N Y Acad Sci* 1127:106, 2008.
91. **Chan RW, Schwab KE, Gargett CE**, Clonogenicity of human endometrial epithelial and stromal cells, *Biol Reprod* 70(6):1738, 2004.
92. **Du H, Taylor HS**, Contribution of bone marrow-derived stem cells to endometrium and endometriosis, *Stem Cells* 25(8):2082, 2007.
93. **Taylor HS**, Endometrial cells derived from donor stem cells in bone marrow transplant recipients, *JAMA* 292(1):81, 2004.
94. **Du H, Naqvi H, Taylor HS**, Ischemia/reperfusion injury promotes and granulocyte-colony stimulating factor inhibits migration of bone marrow-derived stem cells to endometrium, *Stem Cells Dev* 21(18):3324, 2012.
95. **Sakr S, Naqvi H, Komm B, Taylor HS**, Endometriosis impairs bone marrow-derived stem cell recruitment to the uterus whereas bazedoxifene treatment leads to endometriosis regression and improved uterine stem cell engraftment, *Endocrinology* 155(4):1489, 2014.
96. **Moridi I, Mamillapalli R, Cosar E, Ersoy GS, Taylor HS**, Bone marrow stem cell chemotactic activity is induced by elevated CXCL12 in endometriosis, *Reprod Sci* 24(4):526, 2017.
97. **Pluchino N, Mamillapalli R, Moridi I, Tal R, Taylor HS**, G-protein-coupled receptor CXCR7 is overexpressed in human and murine endometriosis, *Reprod Sci* 25(8):1168, 2018. doi:10.1177/1933719118766256.
98. **Wang X, Mamillapalli R, Mutlu L, Du H, Taylor HS**, Chemoattraction of bone marrow-derived stem cells towards human endometrial stromal cells is mediated by estradiol regulated CXCL12 and CXCR4 expression, *Stem Cell Res* 15(1):14, 2015.
99. **Barrier BF**, Immunology of endometriosis, *Clin Obstet Gynecol* 53:397, 2010.
100. **Sinaii N, Cleary SD, Ballweg ML, Nieman LK, Stratton P**, High rates of autoimmune and endocrine disorders, fibromyalgia, chronic fatigue syndrome and atopic diseases among women with endometriosis: a survey analysis, *Hum Reprod* 17:2715, 2002.
101. **Matorras R, Ocerin I, Unamuno M, Nieto A, Peiro E, Burgos J, Exposito A**, Prevalence of endometriosis in women with systemic lupus erythematosus and Sjogren's syndrome, *Lupus* 16:736, 2007.
102. **Pasoto SG, Abrao MS, Viana VS, Bueno C, Leon EP, Bonfa E**, Endometriosis and systemic lupus erythematosus: a comparative evaluation of clinical manifestations and serological autoimmune phenomena, *Am J Reprod Immunol* 53:85, 2005.
103. **Taylor PV, Maloney MD, Campbell JM, Skerrow SM, Nip MM, Parmar R, Tate G**, Autoreactivity in women with endometriosis, *Br J Obstet Gynaecol* 98:680, 1991.
104. **Mathur S, Chihal HJ, Homm RJ, Garza DE, Rust PF, Williamson HO**, Endometrial antigens involved in

the autoimmunity of endometriosis, *Fertil Steril* 50:860, 1988.

105. **Kennedy SH, Starkey PM, Sargent IL, Hicks BR, Barlow DH**, Antiendometrial antibodies in endometriosis measured by an enzyme-linked immunosorbent assay before and after treatment with danazol and nafarelin, *Obstet Gynecol* 75:914, 1990.
106. **Wild RA, Hirisave V, Podczaski ES, Coulam C, Shivers CA, Satyaswaroop PG**, Autoantibodies associated with endometriosis: can their detection predict presence of the disease?, *Obstet Gynecol* 77:927, 1991.
107. **Odukoya OA, Wheatcroft N, Weetman AP, Cooke ID**, The prevalence of endometrial immunoglobulin G antibodies in patients with endometriosis, *Hum Reprod* 10:1214, 1995.
108. **Pillai S, Zhou GX, Arnaud P, Jiang H, Butler WJ, Zhang H**, Antibodies to endometrial transferrin and alpha 2-Heremans Schmidt (HS) glycoprotein in patients with endometriosis, *Am J Reprod Immunol* 35:483, 1996.
109. **Randall GW, Gantt PA, Poe-Zeigler RL, Bergmann CA, Noel ME, Strawbridge WR, Richardson-Cox B, Hereford JR, Reiff RH**, Serum antiendometrial antibodies and diagnosis of endometriosis, *Am J Reprod Immunol* 58:374, 2007.
110. **Inagaki J, Sugiura-Ogasawara M, Nomizu M, Nakatsuka M, Ikuta K, Suzuki N, Kaihara K, Kobayashi K, Yasuda T, Shoenfeld Y, Aoki K, Matsuura E**, An association of IgG anti-laminin-1 autoantibodies with endometriosis in infertile patients, *Hum Reprod* 18:544, 2003.
111. **Herington JL, Bruner-Tran KL, Lucas JA, Osteen KG**, Immune interactions in endometriosis, *Expert Rev Clin Immunol* 7(5):611, 2011.
112. **Haney AF, Muscato JJ, Weinberg JB**, Peritoneal fluid cell populations in infertility patients, *Fertil Steril* 35:696, 1981.
113. **Halme J, Becker S, Hammond MG, Raj MH, Raj S**, Increased activation of pelvic macrophages in infertile women with mild endometriosis, *Am J Obstet Gynecol* 145:333, 1983.
114. **Olive DL, Weinberg JB, Haney AF**, Peritoneal macrophages and infertility: the association between cell number and pelvic pathology, *Fertil Steril* 44:772, 1985.
115. **Hill JA, Faris HM, Schiff I, Anderson DJ**, Characterization of leukocyte subpopulations in the peritoneal fluid of women with endometriosis, *Fertil Steril* 50:216, 1988.
116. **Lebovic DI, Mueller MD, Taylor RN**, Immunobiology of endometriosis, *Fertil Steril* 75:1, 2001.
117. **Sidell N, Han SW, Parthasarathy S**, Regulation and modulation of abnormal immune responses in endometriosis, *Ann N Y Acad Sci* 955:159, 2002.
118. **Bruner-Tran KL, Herington JL, Duleba AJ, Taylor HS, Osteen KG**, Medical management of endometriosis: emerging evidence linking inflammation to disease pathophysiology. *Minerva Ginecol* 65(2):199, 2013.
119. **Kikuchi Y, Ishikawa N, Hirata J, Imaizumi E, Sasa H, Nagata I**, Changes of peripheral blood lymphocyte subsets before and after operation of patients with endometriosis, *Acta Obstet Gynecol Scand* 72:157, 1993.
120. **Oosterlynck DJ, Cornillie FJ, Waer M, Vandeputte M, Koninckx PR**, Women with endometriosis show a defect in natural killer activity resulting in a decreased cytotoxicity to autologous endometrium, *Fertil Steril* 56:45, 1991.
121. **Oosterlynck DJ, Meuleman C, Waer M, Vandeputte M, Koninckx PR**, The natural killer activity of peritoneal fluid lymphocytes is decreased in women with endometriosis, *Fertil Steril* 58:292, 1992.
122. **Ho HN, Chao KH, Chen HF, Wu MY, Yang YS, Lee TY**, Peritoneal natural killer cytotoxicity and CD25+ CD3+ lymphocyte subpopulation are decreased in women with stage III-IV endometriosis, *Hum Reprod* 10:2671, 1995.
123. **Wu MY, Yang JH, Chao KH, Hwang JL, Yang YS, Ho HN**, Increase in the expression of killer cell inhibitory receptors on peritoneal natural killer cells in women with endometriosis, *Fertil Steril* 74:1187, 2000.
124. **Maeda N, Izumiya C, Yamamoto Y, Oguri H, Kusume T, Fukaya T**, Increased killer inhibitory receptor KIR2DL1 expression among natural killer cells in women with pelvic endometriosis, *Fertil Steril* 77:297, 2002.
125. **Dmowski WP, Gebel HM, Braun DP**, The role of cell-mediated immunity in pathogenesis of endometriosis, *Acta Obstet Gynecol Scand* 159(Suppl):7, 1994.

126. **Witz CA, Montoya IA, Dey TD, Schenken RS**, Characterization of lymphocyte subpopulations and T cell activation in endometriosis, *Am J Reprod Immunol* 32:173, 1994.
127. **Seli E, Arici A**, Endometriosis: interaction of immune and endocrine systems, *Semin Reprod Med* 21:135, 2003.
128. **Nematian SE, Mamillapalli R, Kadakia TS, Majidi Zolbin M, Moustafa S, Taylor HS**, Systemic inflammation induced by microRNAs: endometriosis-derived alterations in circulating microRNA 635-5p and Let-7b-5p regulate macrophage cytokine production, *J Clin Endocrinol Metab* 103(1):64, 2018.
129. **Lebovic DI, Bentzien F, Chao VA, Garrett EN, Meng YG, Taylor RN**, Induction of an angiogenic phenotype in endometriotic stromal cell cultures by interleukin-1beta, *Mol Hum Reprod* 6:269, 2000.
130. **Arici A, Tazuke SI, Attar E, Kliman HJ, Olive DL**, Interleukin-8 concentration in peritoneal fluid of patients with endometriosis and modulation of interleukin-8 expression in human mesothelial cells, *Mol Hum Reprod* 2:40, 1996.
131. **Vigano P, Gaffuri B, Somigliana E, Busacca M, Di Blasio AM, Vignali M**, Expression of intercellular adhesion molecule (ICAM)-1 mRNA and protein is enhanced in endometriosis versus endometrial stromal cells in culture, *Mol Hum Reprod* 4:1150, 1998.
132. **Witz CA**, Cell adhesion molecules and endometriosis, *Semin Reprod Med* 21:173, 2003.
133. **Ryan IP, Tseng JF, Schriock ED, Khorram O, Landers DV, Taylor RN**, Interleukin-8 concentrations are elevated in peritoneal fluid of women with endometriosis, *Fertil Steril* 63:929, 1995.
134. **Akoum A, Lawson C, McColl S, Villeneuve M**, Ectopic endometrial cells express high concentrations of interleukin (IL)-8 in vivo regardless of the menstrual cycle phase and respond to oestradiol by up-regulating IL-1-induced IL-8 expression in vitro, *Mol Hum Reprod* 7:859, 2001.
135. **Garcia-Velasco JA, Arici A**, Interleukin-8 stimulates the adhesion of endometrial stromal cells to fibronectin, *Fertil Steril* 72:336, 1999.
136. **Arici A, Seli E, Zeyneloglu HB, Senturk LM, Oral E, Olive DL**, Interleukin-8 induces proliferation of endometrial stromal cells: a potential autocrine growth factor, *J Clin Endocrinol Metab* 83:1201, 1998.
137. **Arici A**, Local cytokines in endometrial tissue: the role of interleukin-8 in the pathogenesis of endometriosis, *Ann N Y Acad Sci* 955:101, 2002.
138. **Jolicoeur C, Boutouil M, Drouin R, Paradis I, Lemay A, Akoum A**, Increased expression of monocyte chemotactic protein-1 in the endometrium of women with endometriosis, *Am J Pathol* 152:125, 1998.
139. **Akoum A, Jolicoeur C, Boucher A**, Estradiol amplifies interleukin-1-induced monocyte chemotactic protein-1 expression by ectopic endometrial cells of women with endometriosis, *J Clin Endocrinol Metab* 85:896, 2000.
140. **Hornung D, Ryan IP, Chao VA, Vigne JL, Schriock ED, Taylor RN**, Immunolocalization and regulation of the chemokine RANTES in human endometrial and endometriosis tissues and cells, *J Clin Endocrinol Metab* 82:1621, 1997.
141. **Arici A, Oral E, Attar E, Tazuke SI, Olive DL**, Monocyte chemotactic protein-1 concentration in peritoneal fluid of women with endometriosis and its modulation of expression in mesothelial cells, *Fertil Steril* 67:1065, 1997.
142. **Khorram O, Taylor RN, Ryan IP, Schall TJ, Landers DV**, Peritoneal fluid concentrations of the cytokine RANTES correlate with the severity of endometriosis, *Am J Obstet Gynecol* 169:1545, 1993.
143. **Akoum A, Lemay A, Brunet C, Hebert J**, Secretion of monocyte chemotactic protein-1 by cytokine-stimulated endometrial cells of women with endometriosis. Le groupe d'investigation en gynecologie, *Fertil Steril* 63:322, 1995.
144. **Akoum A, Lemay A, Brunet C, Hebert J**, Cytokine-induced secretion of monocyte chemotactic protein-1 by human endometriotic cells in culture. The Groupe d'Investigation en Gynecologie, *Am J Obstet Gynecol* 172:594, 1995.
145. **Boucher A, Mourad W, Mailloux J, Lemay A, Akoum A**, Ovarian hormones modulate monocyte chemotactic protein-1 expression in endometrial cells of women with endometriosis, *Mol Hum Reprod* 6:618, 2000.
146. **Zhang RJ, Wild RA, Ojago JM**, Effect of tumor necrosis factor-alpha on adhesion of human endometrial stromal cells to peritoneal mesothelial cells: an in vitro system. *Fertil Steril* 59:1196, 1993.

147. **Debrock S, De Strooper B, Vander Perre S, Hill JA, D'Hooghe TM**, Tumour necrosis factor-alpha, interleukin-6 and interleukin-8 do not promote adhesion of human endometrial epithelial cells to mesothelial cells in a quantitative in vitro model, *Hum Reprod* 21:605, 2006.
148. **Groothuis PG, Nap AW, Winterhager E, Grümmer R**, Vascular development in endometriosis, *Angiogenesis* 8(2):147, 2005.
149. **Taylor RN, Lebovic DI, Mueller MD**, Angiogenic factors in endometriosis, *Ann N Y Acad Sci* 955:89, 2002; discussion 118, 396–406.
150. **McLaren J, Prentice A, Charnock-Jones DS, Smith SK**, Vascular endothelial growth factor (VEGF) concentrations are elevated in peritoneal fluid of women with endometriosis, *Hum Reprod* 11:220, 1996.
151. **Shifren JL, Tseng JF, Zaloudek CJ, Ryan IP, Meng YG, Ferrara N, et al.**, Ovarian steroid regulation of vascular endothelial growth factor in the human endometrium: implications for angiogenesis during the menstrual cycle and in the pathogenesis of endometriosis, *J Clin Endocrinol Metab* 81:3112, 1996.
152. **Donnez J, Smoes P, Gillerot S, Casanas-Roux F, Nisolle M**, Vascular endothelial growth factor (VEGF) in endometriosis, *Hum Reprod* 13(6):1686, 1998.
153. **Kennedy S, Mardon H, Barlow D**, Familial endometriosis, *J Assist Reprod Genet* 12:32, 1995.
154. **Stefansson H, Einarsdottir A, Geirsson RT, Jonsdottir K, Sverrisdottir G, Gudnadottir VG, Gunnarsdottir S, Manolescu A, Gulcher J, Stefansson K**, Endometriosis is not associated with or linked to the GALT gene, *Fertil Steril* 76:1019, 2001.
155. **Stefansson H, Geirsson RT, Steinthorsdottir V, Jonsson H, Manolescu A, Kong A, Ingadottir G, Gulcher J, Stefansson K**, Genetic factors contribute to the risk of developing endometriosis, *Hum Reprod* 17:555, 2002.
156. **Hadfield RM, Yudkin PL, Coe CL, Scheffler J, Uno H, Barlow DH, Kemnitz JW, Kennedy SH**, Risk factors for endometriosis in the rhesus monkey (*Macaca mulatta*): a case-control study, *Hum Reprod Update* 3:109, 1997.
157. **Hadfield RM, Mardon JH, Barlow DH, Kennedy SH**, Endometriosis in monozygotic twins, *Fertil Steril* 68:941, 1997.
158. **Moen MH**, Endometriosis in monozygotic twins, *Acta Obstet Gynecol Scand* 73:59, 1994.
159. **Treloar SA, O'Connor DT, O'Connor VM, Martin NG**, Genetic influences on endometriosis in an Australian twin sample, *Fertil Steril* 71:701, 1999.
160. **Kennedy S, Hadfield R, Mardon H, Barlow D**, Age of onset of pain symptoms in non-twin sisters concordant for endometriosis, *Hum Reprod* 11:403, 1996.
161. **Coxhead D, Thomas EJ**, Familial inheritance of endometriosis in a British population: a case control study, *J Obstet Gynaecol* 13:42, 1993.
162. **Kennedy S, Hadfield R, Westbrook C, Weeks DE, Barlow D, Golding S**, Magnetic resonance imaging to assess familial risk in relatives of women with endometriosis, *Lancet* 352:1440, 1998.
163. **Moen MH, Magnus P**, The familial risk of endometriosis, *Acta Obstet Gynecol Scand* 72:560, 1993.
164. **Simpson JL, Elias S, Malinak LR, Buttram VC Jr**, Heritable aspects of endometriosis. I. Genetic studies, *Am J Obstet Gynecol* 137:327, 1980.
165. **Kennedy S**, Is there a genetic basis to endometriosis? *Semin Reprod Endocrinol* 15:309, 1997.
166. **Kennedy S**, Genetics of endometriosis: a review of the positional cloning approaches, *Semin Reprod Med* 21:111, 2003.
167. **Kao LC, Germeyer A, Tulac S, Lobo S, Yang JP, Taylor RN, Osteen K, Lessey BA, Giudice LC**, Expression profiling of endometrium from women with endometriosis reveals candidate genes for disease-based implantation failure and infertility, *Endocrinology* 144:2870, 2003.
168. **Burney RO, Talbi S, Hamilton AE, Vo KC, Nyegaard M, Nezhat CR, Lessey BA, Giudice LC**, Gene expression analysis of endometrium reveals progesterone resistance and candidate susceptibility genes in women with endometriosis, *Endocrinology* 148:3814, 2007.
169. **Albertsen HM, Chettier R, Farrington P, Ward K**, Genome-wide association study link novel loci to endometriosis, *PLoS One* 8(3):e58257, 2013.
170. **Uno S, Zembutsu H, Hirasawa A, Takahashi A, Kubo M, Akahane T, et al.**, A genome-wide association

study identifies genetic variants in the CDKN2BAS locus associated with endometriosis in Japanese. *Nat Genet* 42(8):707, 2010.

171. **Nyholt DR, Low SK, Anderson CA, Painter JN, Uno S, Morris AP, et al.**, Genome-wide association meta-analysis identifies new endometriosis risk loci. *Nat Genet* 44(12):1355, 2012.
172. **Painter JN, Anderson CA, Nyholt DR, Macgregor S, Lin J, Lee SH, et al.**, Genome-wide association study identifies a locus at 7p15.2 associated with endometriosis. *Nat Genet* 43(1):51, 2011.
173. **Pagliardini L, Gentilini D, Sanchez AM, Candiani M, Vigano P, Di Blasio AM**, Replication and meta-analysis of previous genome-wide association studies confirm vezatin as the locus with the strongest evidence for association with endometriosis. *Hum Reprod* 30(4):987, 2015.
174. **Pagliardini L, Gentilini D, Vigano P, Panina-Bordignon P, Busacca M, Candiani M, et al.**, An Italian association study and meta-analysis with previous GWAS confirm WNT4, CDKN2BAS and FN1 as the first identified susceptibility loci for endometriosis. *J Med Genet* 50(1):43, 2013.
175. **Rahmioglu N, Nyholt DR, Morris AP, Missmer SA, Montgomery GW, Zondervan KT**, Genetic variants underlying risk of endometriosis: insights from meta-analysis of eight genome-wide association and replication datasets. *Hum Reprod Update* 20(5):702, 2014.
176. **Zondervan KT, Rahmioglu N, Morris AP, Nyholt DR, Montgomery GW, Becker CM, et al.**, Beyond endometriosis genome-wide association study: from genomics to phenomics to the patient. *Semin Reprod Med* 34(4):242, 2016.
177. **Grechukhina O, Petracco R, Popkhadze S, Massasa E, Paranjape T, Chan E, et al.**, A polymorphism in a let-7 microRNA binding site of KRAS in women with endometriosis. *EMBO Mol Med* 4(3):206, 2012.
178. **Yoo JY, Kim TH, Fazleabas AT, Palomino WA, Ahn SH, Tayade C, et al.**, KRAS Activation and over-expression of SIRT1/BCL6 contributes to the pathogenesis of endometriosis and progesterone resistance. *Sci Rep* 7(1):6765, 2017.
179. **Kim JJ, Taylor HS, Lu Z, Ladhani O, Hastings JM, Jackson KS, et al.**, Altered expression of HOXA10 in endometriosis: potential role in decidualization. *Mol Hum Reprod* 13(5):323, 2007.
180. **Tseng JF, Ryan IP, Milam TD, Murai JT, Schriock ED, Landers DV, Taylor RN**, Interleukin-6 secretion in vitro is up-regulated in ectopic and eutopic endometrial stromal cells from women with endometriosis. *J Clin Endocrinol Metab* 81:1118, 1996.
181. **Noble LS, Simpson ER, Johns A, Bulun SE**, Aromatase expression in endometriosis. *J Clin Endocrinol Metab* 81:174, 1996.
182. **Noble LS, Takayama K, Zeitoun KM, Putman JM, Johns DA, Hinshelwood MM, Agarwal VR, Zhao Y, Carr BR, Bulun SE**, Prostaglandin E2 stimulates aromatase expression in endometriosis-derived stromal cells. *J Clin Endocrinol Metab* 82:600, 1997.
183. **Lucidi RS, Witz CA, Chrisco M, Binkley PA, Shain SA, Schenken RS**, A novel in vitro model of the early endometriotic lesion demonstrates that attachment of endometrial cells to mesothelial cells is dependent on the source of endometrial cells. *Fertil Steril* 84:16, 2005.
184. **Gebel HM, Braun DP, Tambur A, Frame D, Rana N, Dmowski WP**, Spontaneous apoptosis of endometrial tissue is impaired in women with endometriosis. *Fertil Steril* 69:1042, 1998.
185. **Dmowski WP, Ding J, Shen J, Rana N, Fernandez BB, Braun DP**, Apoptosis in endometrial glandular and stromal cells in women with and without endometriosis. *Hum Reprod* 16:1802, 2001.
186. **Garcia-Velasco JA, Arici A**, Apoptosis and the pathogenesis of endometriosis. *Semin Reprod Med* 21:165, 2003.
187. **Missmer SA, Hankinson SE, Spiegelman D, Barbieri RL, Malspeis S, Willett WC, Hunter DJ**, Reproductive history and endometriosis among premenopausal women. *Obstet Gynecol* 104:965, 2004.
188. **Zeitoun KM, Bulun SE**, Aromatase: a key molecule in the pathophysiology of endometriosis and a therapeutic target. *Fertil Steril* 72:961, 1999.
189. **Gurates B, Bulun SE**, Endometriosis: the ultimate hormonal disease. *Semin Reprod Med* 21:125, 2003.
190. **Bulun SE, Lin Z, Imir G, Amin S, Demura M, Yilmaz B, Martin R, Utsunomiya H, Thung S, Gurates B, Tamura M, Langoi D, Deb S**, Regulation of aromatase expression in estrogen-responsive breast and uterine disease: from bench to treatment. *Pharmacol Rev* 57:359, 2005.



191. **Sun HS, Hsiao KY, Hsu CC, Wu MH, Tsai SJ**, Transactivation of steroidogenic acute regulatory protein in human endometriotic stromal cells is mediated by the prostaglandin EP2 receptor, *Endocrinology* 144:3934, 2003.
192. **Gurates B, Sebastian S, Yang S, Zhou J, Tamura M, Fang Z, Suzuki T, Sasano H, Bulun SE**, WT1 and DAX-1 inhibit aromatase P450 expression in human endometrial and endometriotic stromal cells, *J Clin Endocrinol Metab* 87:4369, 2002.
193. **Jabbour HN, Sales KJ, Smith OP, Battersby S, Boddy SC**, Prostaglandin receptors are mediators of vascular function in endometrial pathologies, *Mol Cell Endocrinol* 252:191, 2006.
194. **Funk CD**, Prostaglandins and leukotrienes: advances in eicosanoid biology, *Science* 294:1871, 2001.
195. **Wu MH, Wang CA, Lin CC, Chen LC, Chang WC, Tsai SJ**, Distinct regulation of cyclooxygenase-2 by interleukin-1beta in normal and endometriotic stromal cells, *J Clin Endocrinol Metab* 90:286, 2005.
196. **Ota H, Igarashi S, Sasaki M, Tanaka T**, Distribution of cyclooxygenase-2 in eutopic and ectopic endometrium in endometriosis and adenomyosis, *Hum Reprod* 16:561, 2001.
197. **Tsai SJ, Wu MH, Lin CC, Sun HS, Chen HM**, Regulation of steroidogenic acute regulatory protein expression and progesterone production in endometriotic stromal cells, *J Clin Endocrinol Metab* 86:5765, 2001.
198. **Zeitoun K, Takayama K, Michael MD, Bulun SE**, Stimulation of aromatase P450 promoter (II) activity in endometriosis and its inhibition in endometrium are regulated by competitive binding of steroidogenic factor-1 and chicken ovalbumin upstream promoter transcription factor to the same cis-acting element, *Mol Endocrinol* 13:239, 1999.
199. **Tamura M, Sebastian S, Yang S, Gurates B, Fang Z, Bulun SE**, Interleukin-1beta elevates cyclooxygenase-2 protein level and enzyme activity via increasing its mRNA stability in human endometrial stromal cells: an effect mediated by extracellularly regulated kinases 1 and 2, *J Clin Endocrinol Metab* 87:3263, 2002.
200. **Tamura M, Sebastian S, Yang S, Gurates B, Ferrer K, Sasano H, Okamura K, Bulun SE**, Up-regulation of cyclooxygenase-2 expression and prostaglandin synthesis in endometrial stromal cells by malignant endometrial epithelial cells. A paracrine effect mediated by prostaglandin E2 and nuclear factor-kappa B, *J Biol Chem* 277:26208, 2002.
201. **Tamura M, Sebastian S, Gurates B, Yang S, Fang Z, Bulun SE**, Vascular endothelial growth factor up-regulates cyclooxygenase-2 expression in human endothelial cells, *J Clin Endocrinol Metab* 87:3504, 2002.
202. **Wu Y, Kajdacsy-Balla A, Strawn E, Basir Z, Halverson G, Jailwala P, Wang Y, Wang X, Ghosh S, Guo SW**, Transcriptional characterizations of differences between eutopic and ectopic endometrium, *Endocrinology* 147:232, 2006.
203. **Osteen KG, Bruner KL, Sharpe-Timms KL**, Steroid and growth factor regulation of matrix metalloproteinase expression and endometriosis, *Semin Reprod Endocrinol* 14:247, 1996.
204. **Sharpe-Timms KL, Cox KE**, Paracrine regulation of matrix metalloproteinase expression in endometriosis, *Ann N Y Acad Sci* 955:147, 2002.
205. **Osteen KG, Yeaman GR, Bruner-Tran KL**, Matrix metalloproteinases and endometriosis, *Semin Reprod Med* 21:155, 2003.
206. **Ulukus M, Ulukus EC, Seval Y, Zheng W, Arici A**, Expression of interleukin-8 receptors in endometriosis, *Hum Reprod* 20:794, 2005.
207. **Kao LC, Tulac S, Lobo S, Imani B, Yang JP, Germeyer A, Osteen K, Taylor RN, Lessey BA, Giudice LC**, Global gene profiling in human endometrium during the window of implantation, *Endocrinology* 143:2119, 2002.
208. **Brosens JJ, Hayashi N, White JO**, Progesterone receptor regulates decidual prolactin expression in differentiating human endometrial stromal cells, *Endocrinology* 140:4809, 1999.
209. **Fazolebas AT, Brudney A, Chai D, Langoi D, Bulun SE**, Steroid receptor and aromatase expression in baboon endometriotic lesions, *Fertil Steril* 80(Suppl 2):820, 2003.
210. **Casey ML, MacDonald PC, Andersson S**, 17 beta-Hydroxysteroid dehydrogenase type 2: chromosomal assignment and progestin regulation of gene expression in human endometrium, *J Clin Invest* 94:2135, 1994.
211. **Mustonen MV, Isomaa VV, Vaskivuo T, Tapanainen J, Poutanen MH, Stenback F, Vihko RK, Vihko**

- PT, Human 17beta-hydroxysteroid dehydrogenase type 2 messenger ribonucleic acid expression and localization in term placenta and in endometrium during the menstrual cycle, *J Clin Endocrinol Metab* 83:1319, 1998.
212. **Cheng YH, Yin P, Xue Q, Yilmaz B, Dawson MI, Bulun SE**, Retinoic acid (RA) regulates 17beta-hydroxysteroid dehydrogenase type 2 expression in endometrium: interaction of RA receptors with specificity protein (SP) 1/SP3 for estradiol metabolism, *J Clin Endocrinol Metab* 93:1915, 2008.
213. **Tseng L, Gurbide E**, Estradiol and 20alpha-dihydroprogesterone dehydrogenase activities in human endometrium during the menstrual cycle, *Endocrinology* 94:419, 1974.
214. **Tseng L, Gurbide E**, Induction of human endometrial estradiol dehydrogenase by progestins, *Endocrinology* 97:825, 1975.
215. **Satyaswaroop PG, Wartell DJ, Mortel R**, Distribution of progesterone receptor, estradiol dehydrogenase, and 20 alpha-dihydroprogesterone dehydrogenase activities in human endometrial glands and stroma: progestin induction of steroid dehydrogenase activities in vitro is restricted to the glandular epithelium, *Endocrinology* 111:743, 1982.
216. **Yang S, Fang Z, Gurates B, Tamura M, Miller J, Ferrer K, Bulun SE**, Stromal PRs mediate induction of 17beta-hydroxysteroid dehydrogenase type 2 expression in human endometrial epithelium: a paracrine mechanism for inactivation of E2, *Mol Endocrinol* 15:2093, 2001.
217. **Lessey BA, Metzger DA, Haney AF, McCarty KS Jr**, Immunohistochemical analysis of estrogen and progesterone receptors in endometriosis: comparison with normal endometrium during the menstrual cycle and the effect of medical therapy, *Fertil Steril* 51:409, 1989.
218. **Vierikko P**, et al., Steroidal regulation of endometriosis tissue: lack of induction of 17 beta-hydroxysteroid dehydrogenase activity by progesterone, medroxyprogesterone acetate, or danazol, *Fertil Steril* 43:218, 1985.
219. **Cheng YH, Imir A, Fenkci V, Yilmaz MB, Bulun SE**, Stromal cells of endometriosis fail to produce paracrine factors that induce epithelial 17beta-hydroxysteroid dehydrogenase type 2 gene and its transcriptional regulator Sp1: a mechanism for defective estradiol metabolism, *Am J Obstet Gynecol* 196:391.e1, 2007.
220. **Zeitoun K, Takayama K, Sasano H, Suzuki T, Moghrabi N, Andersson S, Johns A, Meng L, Putman M, Carr B, Bulun SE**, Deficient 17beta-hydroxysteroid dehydrogenase type 2 expression in endometriosis: failure to metabolize 17beta-estradiol, *J Clin Endocrinol Metab* 83:4474, 1998.
221. **Bulun SE, Cheng YH, Yin P, Imir G, Utsunomiya H, Attar E, Innes J, Julie Kim J**, Progesterone resistance in endometriosis: link to failure to metabolize estradiol, *Mol Cell Endocrinol* 248:94, 2006.
222. **Attia GR, Zeitoun K, Edwards D, Johns A, Carr BR, Bulun SE**, Progesterone receptor isoform A but not B is expressed in endometriosis, *J Clin Endocrinol Metab* 85:2897, 2000.
223. **Giangrande PH, Kimbrel EA, Edwards DP, McDonnell DP**, The opposing transcriptional activities of the two isoforms of the human progesterone receptor are due to differential cofactor binding, *Mol Cell Biol* 20(9):3102, 2000.
224. **Patel BG, Rudnicki M, Yu J, Shu Y, Taylor RN**, Progesterone resistance in endometriosis: origins, consequences and interventions, *Acta Obstet Gynecol Scand* 96(6):623, 2017.
225. **Prentice A, Randall BJ, Weddell A, McGill A, Henry L, Horne CH**, et al., Ovarian steroid receptor expression in endometriosis and in two potential parent epithelia: endometrium and peritoneal mesothelium, *Hum Reprod* 7(9):1318, 1992.
226. **Gonzalez-Ramos R, Van Langendonck A, Defrere S, Lousse JC, Colette S, Devoto L**, et al., Involvement of the nuclear factor-kappaB pathway in the pathogenesis of endometriosis, *Fertil Steril* 94(6):1985, 2010.
227. **Guo SW**, Nuclear factor-kappab (NF-kappaB): an unsuspected major culprit in the pathogenesis of endometriosis that is still at large? *Gynecol Obstet Invest* 63(2):71, 2007.
228. **Jackson KS, Brudney A, Hastings JM, Mavrogianis PA, Kim JJ, Fazleabas AT**, The altered distribution of the steroid hormone receptors and the chaperone immunophilin FKBP52 in a baboon model of endometriosis is associated with progesterone resistance during the window of uterine receptivity, *Reprod Sci* 14:137, 2007.
229. **Aghajanova L, Velarde MC, Giudice LC**, The progesterone receptor coactivator Hic-5 is involved in the pathophysiology of endometriosis, *Endocrinology* 150:3863, 2009.

230. **Al-Sabbagh M, Lam EW, Brosens JJ**, Mechanisms of endometrial progesterone resistance, *Mol Cell Endocrinol* 25:208, 2012.
231. **Wu Y, Strawn E, Basir Z, Halverson G, Guo SW**, Promoter hypermethylation of progesterone receptor isoform B (PR-B) in endometriosis, *Epigenetics* 1(2):106, 2006.
232. **Wu Y, Shi X, Guo S**, The knockdown of progesterone receptor isoform B (PR-B) promotes proliferation in immortalized endometrial stromal cells, *Fertil Steril* 90:1320, 2008.
233. **Wu Y, Strawn E, Basir Z, Halverson G, Guo SW**, Aberrant expression of deoxyribonucleic acid methyltransferases DNMT1, DNMT3A, and DNMT3B in women with endometriosis, *Fertil Steril* 87:24, 2007.
234. **Xue Q, Lin Z, Yin P, Milad MP, Cheng YH, Confino E, Reierstad S, Bulun SE**, Transcriptional activation of steroidogenic factor-1 by hypomethylation of the 5¢ CpG island in endometriosis, *J Clin Endocrinol Metab* 92:3261, 2007.
235. **Utsunomiya H, Cheng YH, Lin Z, Reierstad S, Yin P, Attar E, Xue Q, Imir G, Thung S, Trukhacheva E, Suzuki T, Sasano H, Kim JJ, Yaegashi N, Bulun SE**, Upstream stimulatory factor-2 regulates steroidogenic factor-1 expression in endometriosis, *Mol Endocrinol* 22:904, 2008.
236. **Xue Q, Lin Z, Cheng YH, Huang CC, Marsh E, Yin P, Milad MP, Confino E, Reierstad S, Innes J, Bulun SE**, Promoter methylation regulates estrogen receptor 2 in human endometrium and endometriosis, *Biol Reprod* 77:681, 2007.
237. **Petracco R, Grechukhina O, Popkhadze S, Massasa E, Zhou Y, Taylor HS**, MicroRNA 135 regulates HOXA10 expression in endometriosis, *J Clin Endocrinol Metab* 96(12):E1925, 2011.
238. **Ghazal S, McKinnon B, Zhou J, Mueller M, Men Y, Yang L, Mueller M, Flannery C, Huang Y, Taylor HS**, H19 lncRNA alters stromal cell growth via IGF signaling in the endometrium of women with endometriosis, *EMBO Mol Med* 7(8):996, 2015.
239. **Practice Committee of the American Society for Reproductive Medicine**, Treatment of pelvic pain associated with endometriosis: a committee opinion, *Fertil Steril* 101(4):927, 2014.
240. **Porpora MG, Koninckx PR, Piazze J, Natili M, Colagrande S, Cosmi EV**, Correlation between endometriosis and pelvic pain, *J Am Assoc Gynecol Laparosc* 6:429, 1999.
241. **Donnez J, Nisolle M, Smoes P, Gillet N, Beguin S, Casanas-Roux F**, Peritoneal endometriosis and “endometriotic” nodules of the rectovaginal septum are two different entities, *Fertil Steril* 66:362, 1996.
242. **Anaf V, Simon P, El Nakadi I, Fayt I, Buxant F, Simonart T, Peny MO, Noel JC**, Relationship between endometriotic foci and nerves in rectovaginal endometriotic nodules, *Hum Reprod* 15:1744, 2000.
243. **Wang G, Tokushige N, Markham R, Fraser IS**, Rich innervation of deep infiltrating endometriosis, *Hum Reprod* 24:827, 2009.
244. **Tran LV, Tokushige N, Berbic M, Markham R, Fraser IS**, Macrophages and nerve fibres in peritoneal endometriosis, *Hum Reprod* 24:835, 2009.
245. **Gruppos Italiano per lo Studio Dell’Endometriosi**, Relationship between stage, site and morphological characteristics of pelvic endometriosis and pain, *Hum Reprod* 16:2668, 2001.
246. **Vercellini P, Fedele L, Aimi G, Pietropaolo G, Consonni D, Crosignani PG**, Association between endometriosis stage, lesion type, patient characteristics and severity of pelvic pain symptoms: a multivariate analysis of over 1000 patients, *Hum Reprod* 22(1):266, 2007.
247. **Bajaj P, Madsen H, Arendt-Nielsen L**, Endometriosis is associated with central sensitization: a psychophysical controlled study, *J Pain* 4:372, 2003.
248. **Li T, Mamillapalli R, Ding S, Chang H, Liu Z-W, Gao X-B, Taylor HS**, Endometriosis alters brain electrophysiology, gene expression and increases pain sensitization, anxiety, and depression in female mice, *Biol Reprod* 99 (2):349, 2018.
249. **Riley JL III, Robinson ME, Wise EA, Price DD**, A meta-analytic review of pain perception across the menstrual cycle, *Pain* 81:225, 1999.
250. **Takayama K, Zeitoun K, Gunby RT, Sasano H, Carr BR, Bulun SE**, Treatment of severe postmenopausal endometriosis with an aromatase inhibitor, *Fertil Steril* 69:709, 1998.
251. **Kubli-Garfias C**, Modulatory action of 5-reduced androgens and progestogens on the excitability of CNS and smooth muscle, *J Steroid Biochem* 27:631, 1987.

252. **Matorras R, Rodriguez F, Pijoan JI, Etxanojauregui A, Neyro JL, Elorriaga MA, Rodriguez-Escudero FJ**, Women who are not exposed to spermatozoa and infertile women have similar rates of stage I endometriosis, *Fertil Steril* 76:923, 2001.
253. **Olive DL, Stohs GF, Metzger DA, Franklin RR**, Expectant management and hydrotubations in the treatment of endometriosis-associated infertility, *Fertil Steril* 44:35, 1985.
254. **Garcia CF, Davis SS**, Pelvic endometriosis: infertility and pelvic pain, *Am J Obstet Gynecol* 129:740, 1977.
255. **Schenken RS, Malinak LR**, Conservative surgery versus expectant management for the infertile patient with mild endometriosis, *Fertil Steril* 37:183, 1982.
256. **Seibel M, Berger MJ, Weinstein FG, Taymor ML**, The effectiveness of danazol on subsequent fertility in minimal endometriosis, *Fertil Steril* 38:534, 1982.
257. **Portuondo JA, Etxanojauregui AD, Herran C, Alijarte I**, Early conception in patients with untreated mild endometriosis, *Fertil Steril* 39:22, 1983.
258. **Hughes EG**, The effectiveness of ovulation induction and intrauterine insemination in the treatment of persistent infertility: a meta-analysis, *Hum Reprod* 12:1865, 1997.
259. **Tanbo T, Fedorcsak P**, Endometriosis-associated infertility: aspects of pathophysiological mechanisms and treatment options, *Acta Obstet Gynecol Scand* 96(6):659, 2017.
260. **Marcoux S, Maheux R, Berube S**, Laparoscopic surgery in infertile women with minimal or mild endometriosis. Canadian Collaborative Group on Endometriosis, *New Engl J Med* 337:217, 1997.
261. **Jacobson TZ, Barlow DH, Koninckx PR, Olive D, Farquhar C**, Laparoscopic surgery for subfertility associated with endometriosis, *Cochrane Database Syst Rev* CD001398, 2002.
262. **AlKudmani B, Gat I, Buell D, Salman J, Zohni K, Librach C, Sharma P**, In vitro fertilization success rates after surgically treated endometriosis and effect of time interval between surgery and in vitro fertilization, *J Minim Invasive Gynecol* 25(1):99, 2018.
263. **Schenken RS, Asch RH, Williams RF, Hodgen GD**, Etiology of infertility in monkeys with endometriosis: luteinized unruptured follicles, luteal phase defects, pelvic adhesions, and spontaneous abortions, *Fertil Steril* 41:122, 1984.
264. **Hornstein MD, Barbieri RL, McShane PM**, Effects of previous ovarian surgery on the follicular response to ovulation induction in an in vitro fertilization program, *J Reprod Med* 34:277, 1989.
265. **Pal L, Shifren JL, Isaacson KB, Chang Y, Leykin L, Toth TL**, Impact of varying stages of endometriosis on the outcome of in vitro fertilization-embryo transfer, *J Assist Reprod Genet* 15:27, 1998.
266. **Toya M, Saito H, Ohta N, Saito T, Kaneko T, Hiroi M**, Moderate and severe endometriosis is associated with alterations in the cell cycle of granulosa cells in patients undergoing in vitro fertilization and embryo transfer, *Fertil Steril* 73:344, 2000.
267. **Holoch KJ, Lessey BA**, Endometriosis and infertility, *Clin Obstet Gynecol* 53(2):429, 2010.
268. **Morcus RN, Gibbons WE, Findley WE**, Effect of peritoneal fluid on in vitro cleavage of 2-cell mouse embryos: possible role in infertility associated with endometriosis, *Fertil Steril* 44(5):678, 1985.
269. **Lessey BA, Ilesanmi AO, Castelbaum AJ, Yuan L, Somkuti SG, Chwalisz K, Satyaswaroop PG**, Characterization of the functional progesterone receptor in an endometrial adenocarcinoma cell line (Ishikawa): progesterone-induced expression of the alpha1 integrin, *J Steroid Biochem Mol Biol* 59(1):31, 1996.
270. **Osteen KG, Keller NR, Feltus FA, Melner MH**, Paracrine regulation of matrix metalloproteinase expression in the normal human endometrium, *Gynecol Obstet Invest* 48(Suppl 1):2, 1999.
271. **Mohamed OA, Jonnaert M, Labelle-Dumais C, Kuroda K, Clarke HJ, Dufort D**, Uterine Wnt/beta-catenin signaling is required for implantation, *Proc Natl Acad Sci U S A* 102(24):8579, 2005.
272. **Hou X, Tan Y, Li M, Dey SK, Das SK**, Canonical Wnt signaling is critical to estrogen-mediated uterine growth, *Mol Endocrinol* 18(12):3035, 2004.
273. **Zanatta A, Rocha AM, Carvalho FM, Pereira RM, Taylor HS, Motta EL, et al.**, The role of the Hoxa10/HOXA10 gene in the etiology of endometriosis and its related infertility: a review, *J Assist Reprod Genet* 27(12):701, 2010.
274. **Taylor HS, Bagot C, Kardana A, Olive D, Arici A**, HOX gene expression is altered in the endometrium of women with endometriosis, *Hum Reprod* 14(5):1328, 1999.

275. **Taylor HS, Arici A, Olive D, Igarashi P**, HOXA10 is expressed in response to sex steroids at the time of implantation in the human endometrium, *J Clin Invest* 101(7):1379, 1998.
276. **Daftary GS, Troy PJ, Bagot CN, Young SL, Taylor HS**, Direct regulation of beta3-integrin subunit gene expression by HOXA10 in endometrial cells, *Mol Endocrinol* 16(3):571, 2002.
277. **Cakmak H, Taylor HS**, Molecular mechanisms of treatment resistance in endometriosis: the role of progesterone-hox gene interactions, *Semin Reprod Med* 28(1):69, 2010.
278. **Daftary GS, Taylor HS**, Endocrine regulation of HOX genes, *Endocr Rev* 27(4):331, 2006.
279. **Santamaria X, Massasa EE, Taylor HS**, Migration of cells from experimental endometriosis to the uterine endometrium, *Endocrinology* 153:5566, 2012.
280. **Hufnagel D, Li F, Cosar E, Krikun G, Taylor HS**, The role of stem cells in the etiology and pathophysiology of endometriosis, *Semin Reprod Med* 33(5):333, 2015.
281. **Lessey BA, Kim JJ**, Endometrial receptivity in the eutopic endometrium of women with endometriosis: it is affected, and let me show you why, *Fertil Steril* 108(1):19, 2017.
282. **Barnhart K, Dunsmoor-Su R, Coutifaris C**, Effect of endometriosis on in vitro fertilization, *Fertil Steril* 77:1148, 2002.
283. **Harb HM, Gallos ID, Chu J, Harb M, Coomarasamy A**, The effect of endometriosis on in vitro fertilisation outcome: a systematic review and meta-analysis, *BJOG* 120:1308, 2013.
284. **Brosens I**, Endometriosis and the outcome of in vitro fertilization, *Fertil Steril* 81:1198, 2004.
285. **Gibbons WE**, Management of endometriosis in fertility patients, *Fertil Steril* 81:1204, 2004.
286. **Senapati S, Sammel MD, Morse C, Barnhart KT**, Impact of endometriosis on in vitro fertilization outcomes: an evaluation of the Society for Assisted Reproductive Technologies Database, *Fertil Steril* 106(1):164, 2016.
287. **Society for Assisted Reproductive Technology**, <https://www.sart.org>
288. **Garcia-Velasco J, Arici A**, Is the endometrium or the oocyte/embryo affected in endometriosis? *Hum Reprod* 14(Suppl 2):77, 1999.
289. **Simon C, Gutierrez A, Vidal A, de los Santos MJ, Tarin JJ, Remohi J, Pellicer A**, Outcome of patients with endometriosis in assisted reproduction: results from in-vitro fertilization and oocyte donation, *Hum Reprod* 9:725, 1994.
290. **Sung L, Mukherjee T, Takeshige T, Bustillo M, Copperman AB**, Endometriosis is not detrimental to embryo implantation in oocyte recipients, *J Assist Reprod Genet* 14:152, 1997.
291. **Pellicer A, Oliveira N, Ruiz A, Remohi J, Simon C**, Exploring the mechanism(s) of endometriosis-related infertility: an analysis of embryo development and implantation in assisted reproduction, *Hum Reprod* 10(Suppl 2):91, 1995.
292. **Diaz I, Navarro J, Blasco L, Simon C, Pellicer A, Remohi J**, Impact of stage III-IV endometriosis on recipients of sibling oocytes: matched case-control study, *Fertil Steril* 74:31, 2000.
293. **Brizek CL, Schlaff S, Pellegrini VA, Frank JB, Worriolow KC**, Increased incidence of aberrant morphological phenotypes in human embryogenesis—an association with endometriosis, *J Assist Reprod Genet* 12:106, 1995.
294. **Garrido N, Pellicer A, Remohi J, Simon C**, Uterine and ovarian function in endometriosis, *Semin Reprod Med* 21:183, 2003.
295. **Guidice LC**, Genomics' role in understanding the pathogenesis of endometriosis, *Semin Reprod Med* 21:119, 2003.
296. **Groll M**, Endometriosis and spontaneous abortion, *Fertil Steril* 41:933, 1984.
297. **Wheeler JM, Johnston BM, Malinak LR**, The relationship of endometriosis to spontaneous abortion, *Fertil Steril* 39:656, 1983.
298. **Olive DL, Franklin RR, Gratkins LV**, The association between endometriosis and spontaneous abortion. A retrospective clinical study, *J Reprod Med* 27:333, 1982.
299. **Metzger DA, Olive DL, Stohs GF, Franklin RR**, Association of endometriosis and spontaneous abortion: effect of control group selection, *Fertil Steril* 45:18, 1986.
300. **FitzSimmons J, Stahl R, Gocial B, Shapiro SS**, Spontaneous abortion and endometriosis, *Fertil Steril* 47:696,

1987.

301. **Cosar E, Mamillapalli R, Ersoy GS, Cho S, Seifer B, Taylor HS**, Serum microRNAs as diagnostic markers of endometriosis: a comprehensive array-based analysis, *Fertil Steril* 106(02):402, 2016.
302. **Sinaï N, Plumb K, Cotton L, Lambert A, Kennedy S, Zondervan K, Stratton P**, Differences in characteristics among 1,000 women with endometriosis based on extent of disease, *Fertil Steril* 89:538, 2008.
303. **Ballard KD, Seaman HE, de Vries CS, Wright JT**, Can symptomatology help in the diagnosis of endometriosis? Findings from a national case-control study—Part 1, *Br J Obstet Gynaecol* 115:1382, 2008.
304. **Husby GK, Haugen RS, Moen MH**, Diagnostic delay in women with pain and endometriosis, *Acta Obstet Gynecol Scand* 82:649, 2003.
305. **Mahmood TA, Templeton AA, Thomson L, Fraser C**, Menstrual symptoms in women with pelvic endometriosis, *Br J Obstet Gynaecol* 98:558, 1991.
306. **Davis GD, Thillet E, Lindemann J**, Clinical characteristics of adolescent endometriosis, *J Adolesc Health* 14:362, 1993.
307. **Koninckx PR, Meuleman C, Demeyere S, Lesaffre E, Cornillie FJ**, Suggestive evidence that pelvic endometriosis is a progressive disease, whereas deeply infiltrating endometriosis is associated with pelvic pain, *Fertil Steril* 55:759, 1991.
308. **Fauconnier A, Chapron C, Dubuisson JB, Vieira M, Dousset B, Breart G**, Relation between pain symptoms and the anatomic location of deep infiltrating endometriosis, *Fertil Steril* 78:719, 2002.
309. **Chapron C, Barakat H, Fritel X, Dubuisson JB, Breart G, Fauconnier A**, Presurgical diagnosis of posterior deep infiltrating endometriosis based on a standardized questionnaire, *Hum Reprod* 20:507, 2005.
310. **Vercellini P, Trespidi L, De Giorgi O, Cortesi I, Parazzini F, Crosignani PG**, Endometriosis and pelvic pain: relation to disease stage and localization, *Fertil Steril* 65:299, 1996.
311. **Fedele L, Bianchi S, Bocciolone L, Di Nola G, Parazzini F**, Pain symptoms associated with endometriosis, *Obstet Gynecol* 79:767, 1992.
312. **Brenner C, Wohlgemuth S**, Scar endometriosis, *Surg Gynecol Obstet* 170:538, 1990.
313. **Wolf Y, Haddad R, Werbin N, Skornick Y, Kaplan O**, Endometriosis in abdominal scars: a diagnostic pitfall, *Am Surg* 62:1042, 1996.
314. **Azzena A, Litta P, Ferrara A, Perin D, Brotto M, Chiarelli S, Sandei F**, Rectosigmoid endometriosis: diagnosis and surgical management, *Clin Exp Obstet Gynecol* 25:94, 1998.
315. **Yantiss RK, Clement PB, Young RH**, Endometriosis of the intestinal tract: a study of 44 cases of a disease that may cause diverse challenges in clinical and pathologic evaluation, *Am J Surg Pathol* 25:445, 2001.
316. **Donnez J, Spada F, Squifflet J, Nisolle M**, Bladder endometriosis must be considered as bladder adenomyosis, *Fertil Steril* 74:1175, 2000.
317. **Redwine DB**, Diaphragmatic endometriosis: diagnosis, surgical management, and long-term results of treatment, *Fertil Steril* 77:288, 2002.
318. **Rychlik DF, Bieber EJ**, Thoracic endometriosis syndrome resembling pulmonary embolism, *J Am Assoc Gynecol Laparosc* 8:445, 2001.
319. **Fedele L, Bianchi S, Raffaelli R, Zanconato G, Zanette G**, Phantom endometriosis of the sciatic nerve, *Fertil Steril* 72:727, 1999.
320. **Taylor HS, Adamson GD, Diamond MP, Goldstein SR, Horne AW, Missmer SA, Snabes MC, Surrey E, Taylor RN**, An evidence-based approach to assessing surgical versus clinical diagnosis of symptomatic endometriosis, *Int J Gynaecol Obstet* 142(2):131, 2018.
321. **Taylor HS**, Clinical diagnosis of endometriosis and optimal medical therapy, *Fertil Steril* 108(5):759, 2017.
322. **American College of Obstetricians and Gynecologists**, ACOG Committee Opinion Number 310, April 2005. Endometriosis in adolescents, *Obstet Gynecol* 105:921, 2005.
323. **Matorras R, Rodriguez F, Pijoan JI, Soto E, Perez C, Ramon O, Rodriguez-Escudero F**, Are there any clinical signs and symptoms that are related to endometriosis in infertile women? *Am J Obstet Gynecol* 174:620, 1996.
324. **Ripps BA, Martin DC**, Correlation of focal pelvic tenderness with implant dimension and stage of endometriosis, *J Reprod Med* 37:620, 1992.

325. **Koninckx PR, Meuleman C, Oosterlynck D, Cornillie FJ**, Diagnosis of deep endometriosis by clinical examination during menstruation and plasma CA-125 concentration, *Fertil Steril* 65:280, 1996.
326. **Spaczynski RZ, Duleba AJ**, Diagnosis of endometriosis, *Semin Reprod Med* 21:193, 2003.
327. **Barbieri RL, Niloff JM, Bast RC Jr, Schaeztl E, Kistner RW, Knapp RC**, Elevated serum concentrations of CA-125 in patients with advanced endometriosis, *Fertil Steril* 45:630, 1986.
328. **Pittaway DE, Fayez JA**, The use of CA-125 in the diagnosis and management of endometriosis, *Fertil Steril* 46:790, 1986.
329. **Koninckx PR, Riittinen L, Seppala M, Cornillie FJ**, CA-125 and placental protein 14 concentrations in plasma and peritoneal fluid of women with deeply infiltrating pelvic endometriosis, *Fertil Steril* 57:523, 1992.
330. **Pittaway DE, Fayez JA**, Serum CA-125 antigen levels increase during menses, *Am J Obstet Gynecol* 156:75, 1987.
331. **Bon GG, Kenemans P, Dekker JJ, Hompes PG, Verstraeten RA, van Kamp GJ, Schoemaker J**, Fluctuations in CA 125 and CA 15-3 serum concentrations during spontaneous ovulatory cycles, *Hum Reprod* 14:566, 1999.
332. **Mol BW, Bayram N, Lijmer JG, Wiegerinck MA, Bongers MY, van der Veen F, Bossuyt PM**, The performance of CA-125 measurement in the detection of endometriosis: a meta-analysis, *Fertil Steril* 70:1101, 1998.
333. **Hirsch M, Duffy J, Davis CJ, Nieves Plana M, Khan KS**, Diagnostic accuracy of cancer antigen 125 for endometriosis: a systematic review and meta-analysis, *BJOG* 123(11):1761, 2016.
334. **Franssen AMHW, van der Heijden PFM, Thomas CMG, Doesburg WH, Willemsen WNP, Rolland R**, On the origin and significance of serum CA-125 concentrations in 97 patients with endometriosis before, during, and after buserelin acetate, nafarelin, or danazol, *Fertil Steril* 57:974, 1992.
335. **Chen FP, Soong YK, Lee N, Lo SK**, The use of serum CA-125 as a marker for endometriosis in patients with dysmenorrhea for monitoring therapy and for recurrence of endometriosis, *Acta Obstet Gynecol Scand* 77:665, 1998.
336. **Pittaway DE**, The use of serial CA-125 concentrations to monitor endometriosis in infertile women, *Am J Obstet Gynecol* 163:1032, 1990.
337. **Pittaway DE, Rondinone D, Miller KA, Barnes K**, Clinical evaluation of CA-125 concentrations as a prognostic factor for pregnancy in infertile women with surgically treated endometriosis, *Fertil Steril* 64:321, 1995.
338. **Iorio MV, Ferracin M, Liu CG, Veronese A, Spizzo R, Sabbioni S, et al.**, MicroRNA gene expression deregulation in human breast cancer, *Cancer Res* 65:7065, 2005.
339. **Akao Y, Nakagawa Y, Naoe T**, MicroRNA-143 and -145 in colon cancer. *DNA Cell Biol* 26:311, 2007.
340. **Yang H, Kong W, He L, Zhao JJ, O'Donnell JD, Wang J, et al.**, MicroRNA expression profiling in human ovarian cancer: miR-214 induces cell survival and cisplatin resistance by targeting PTEN, *Cancer Res* 68:425, 2008.
341. **Small EM, Olson EN**, Pervasive roles of microRNAs in cardiovascular biology, *Nature* 469:336, 2011.
342. **Brest P, Lapaquette P, Souidi M, Lebrigand K, Cesaro A, Vouret-Craviari V, et al.**, A synonymous variant in IRGM alters a binding site for miR-196 and causes deregulation of IRGM-dependent xenophagy in Crohn's disease, *Nat Genet* 43:242, 2011.
343. **Yang N, Kaur S, Volinia S, Greshock J, Lassus H, Hasegawa K, et al.**, MicroRNA microarray identifies Let-7i as a novel biomarker and therapeutic target in human epithelial ovarian cancer, *Cancer Res* 68:10307, 2008.
344. **Marsh EE, Lin Z, Yin P, Milad M, Chakravarti D, Bulun SE**, Differential expression of microRNA species in human uterine leiomyoma versus normal myometrium, *Fertil Steril* 89:1771, 2008.
345. **Mitchell PS, Parkin RK, Kroh EM, Fritz BR, Wyman SK, Pogosova-Agadjanyan EL, et al.**, Circulating microRNAs as stable blood-based markers for cancer detection, *Proc Natl Acad Sci U S A* 105:10513, 2008.
346. **Resnick KE, Alder H, Hagan JP, Richardson DL, Croce CM, Cohn DE**, The detection of differentially expressed microRNAs from the serum of ovarian cancer patients using a novel real-time PCR platform, *Gynecol Oncol* 112:55, 2009.

347. **Wang F, Zheng Z, Guo J, Ding X**, Correlation and quantitation of microRNA aberrant expression in tissues and sera from patients with breast tumor, *Gynecol Oncol* 119:586, 2010.
348. **Cho S, Mutlu L, Grechukhina O, Taylor HS**, Circulating microRNAs as potential biomarkers for endometriosis, *Fertil Steril* 103(05):1252, 2015.
349. **Seifer BJ, Su D, Taylor HS**, Circulating miRNAs in murine experimental endometriosis, *Reprod Sci* 24(03):376, 2017.
350. **Alcázar JL, Laparte C, Jurado M, López-García G**, The role of transvaginal ultrasonography combined with color velocity imaging and pulsed Doppler in the diagnosis of endometrioma, *Fertil Steril* 67:487, 1997.
351. **Patel MD, Feldstein VA, Chen DC, Lipson SD, Filly RA**, Endometriomas: diagnostic performance of US, *Radiology* 210:739, 1999.
352. **Mais V, Guerriero S, Ajossa S, Angiolucci M, Paoletti AM, Melis GB**, The efficiency of transvaginal ultrasonography in the diagnosis of endometrioma, *Fertil Steril* 60:776, 1993.
353. **Guerriero S, Ajossa S, Paoletti AM, Mais V, Angiolucci M, Melis GB**, Tumor markers and transvaginal ultrasonography in the diagnosis of endometrioma, *Obstet Gynecol* 88:403, 1996.
354. **Kennedy S, Bergqvist A, Chapron C, D'Hooghe T, Dunselman G, Greb R, Hummelshoj L, Prentice A, Saridogan E**, ESHRE guideline for the diagnosis and treatment of endometriosis, *Hum Reprod* 20:2698, 2005.
355. **Abrao MS, Goncalves MO, Dias JA Jr, Podgaec S, Chamie LP, Blasbalg R**, Comparison between clinical examination, transvaginal sonography and magnetic resonance imaging for the diagnosis of deep endometriosis, *Hum Reprod* 22:3092, 2007.
356. **Bazot M, Malzy P, Cortez A, Roseau G, Amouyal P, Darai E**, Accuracy of transvaginal sonography and rectal endoscopic sonography in the diagnosis of deep infiltrating endometriosis, *Ultrasound Obstet Gynecol* 30:994, 2007.
357. **Bazot M, Lafont C, Rouzier R, Roseau G, Thomassin-Naggara I, Darai E**, Diagnostic accuracy of physical examination, transvaginal sonography, rectal endoscopic sonography, and magnetic resonance imaging to diagnose deep infiltrating endometriosis, *Fertil Steril* 92:1825, 2009.
358. **Hudelist G, Oberwinkler KH, Singer CF, Tuttlies F, Rauter G, Ritter O, Keckstein J**, Combination of transvaginal sonography and clinical examination for preoperative diagnosis of pelvic endometriosis, *Hum Reprod* 24:1018, 2009.
359. **Hudelist G, Tuttlies F, Rauter G, Pucher S, Keckstein J**, Can transvaginal sonography predict infiltration depth in patients with deep infiltrating endometriosis of the rectum?, *Hum Reprod* 24:1012, 2009.
360. **Piketty M, Chopin N, Dousset B, Millischer-Bellaische AE, Roseau G, Leconte M, Borghese B, Chapron C**, Preoperative work-up for patients with deeply infiltrating endometriosis: transvaginal ultrasonography must definitely be the first-line imaging examination, *Hum Reprod* 24:602, 2009.
361. **Savelli L, Manuzzi L, Pollastri P, Mabrouk M, Seracchioli R, Venturoli S**, Diagnostic accuracy and potential limitations of transvaginal sonography for bladder endometriosis, *Ultrasound Obstet Gynecol* 34:595, 2009.
362. **Arrive L, Hricak H, Martin MC**, Pelvic endometriosis: MR imaging, *Radiology* 171:687, 1989.
363. **Togashi K, Nishimura K, Kimura I, Tsuda Y, Yamashita K, Shibata T, Nakano Y, Konishi J, Konishi I, Mori T**, Endometrial cysts: diagnosis with MR imaging, *Radiology* 180:73, 1991.
364. **Stratton P, Winkel C, Premkumar A, Chow C, Wilson J, Hearn-Stokes R, Heo S, Merino M, Nieman LK**, Diagnostic accuracy of laparoscopy, magnetic resonance imaging, and histopathologic examination for the detection of endometriosis, *Fertil Steril* 79:1078, 2003.
365. **Ascher SM, Agrawal R, Bis KG, Brown ED, Maximovich A, Markham SM, Patt RH, Semelka RC**, Endometriosis: appearance and detection with conventional and contrast-enhanced fat-suppressed spin-echo techniques, *J Magn Reson Imaging* 5:251, 1995.
366. **Kinkel K, Chapron C, Balleyguier C, Fritel X, Dubuisson JB, Moreau JF**, Magnetic resonance imaging characteristics of deep endometriosis, *Hum Reprod* 14:1080, 1999.
367. **Martin DC, Hubert GD, Vander Zwaag R, el-Zeky FA**, Laparoscopic appearances of peritoneal endometriosis, *Fertil Steril* 51:63, 1989.



368. **Stripling MC, Martin DC, Chatman DL, Zwaag RV, Poston WM**, Subtle appearance of pelvic endometriosis, *Fertil Steril* 49:427, 1988.
369. **Stegmann BJ, Sinaii N, Liu S, Segars J, Merino M, Nieman LK, Stratton P**, Using location, color, size, and depth to characterize and identify endometriosis lesions in a cohort of 133 women, *Fertil Steril* 89:1632, 2008.
370. **Jansen RPS, Russell P**, Nonpigmented endometriosis: clinical, laparoscopic and pathologic definition, *Am J Obstet Gynecol* 155:1154, 1986.
371. **Gustofson RL, Kim N, Liu S, Stratton P**, Endometriosis and the appendix: a case series and comprehensive review of the literature, *Fertil Steril* 86:298, 2006.
372. **Nisolle M, Paindaveine B, Bourdon A, Berlière M, Casanas-Roux F, Donnez J**, Histologic study of peritoneal endometriosis in infertile women, *Fertil Steril* 53:984, 1990.
373. **Moen MH, Halvorsen TB**, Histologic confirmation of endometriosis in different peritoneal lesions, *Acta Obstet Gynecol Scand* 71:337, 1992.
374. **Redwine DB**, Age-related evolution in color appearance of endometriosis, *Fertil Steril* 48:1062, 1987.
375. **Wiegerinck MA, Van Dop PA, Brosens I**, The staging of peritoneal endometriosis by the type of active lesion in addition to the revised American Fertility Society classification, *Fertil Steril* 60:461, 2001.
376. **Walter AJ, Hentz JG, Magtibay PM, Cornella JL, Magrina JF**, Endometriosis: correlation between histologic and visual findings at laparoscopy, *Am J Obstet Gynecol* 184:1407, 2001.
377. **Winkel CA**, Evaluation and management of women with endometriosis, *Obstet Gynecol* 102:397, 2003.
378. **Wykes CB, Clark TJ, Khan KS**, Accuracy of laparoscopy in the diagnosis of endometriosis: a systematic quantitative review, *Br J Obstet Gynaecol* 111:1204, 2004.
379. **Vercellini P, Vendola N, Bocciolone L, Rognoni MT, Carinelli SG, Candiani GB**, Reliability of the visual diagnosis of ovarian endometriosis, *Fertil Steril* 56:1198, 1991.
380. **Nezhat F, Nezhat C, Allan CJ, Metzger DA, Sears DL**, Clinical and histologic classification of endometriomas. Implications for a mechanism of pathogenesis, *J Reprod Med* 37:771, 1992.
381. **Candiani GB, Vercellini P, Fedele L**, Laparoscopic ovarian puncture for correct staging of endometriosis, *Fertil Steril* 53:994, 1990.
382. **Redwine DB**, Ovarian endometriosis: a marker for more extensive pelvic and intestinal disease, *Fertil Steril* 72:310, 1999.
383. **Nisolle M, Donnez J**, Peritoneal endometriosis, ovarian endometriosis, and adenomyotic nodules of the rectovaginal septum are three different entities, *Fertil Steril* 68:585, 1997.
384. **Donnez J, Nisolle M, Gillerot S, Smets M, Bassil S, Casanas-Roux F**, Rectovaginal septum adenomyotic nodules: a series of 500 cases, *Br J Obstet Gynaecol* 104:1014, 1997.
385. **American Fertility Society**, Classification of endometriosis, *Fertil Steril* 32:633, 1979.
386. **Buttram VC Jr**, Evolution of the revised American Fertility Society classification of endometriosis, *Fertil Steril* 43:347, 1985.
387. **American Society for Reproductive Medicine**, Revised American Society for Reproductive Medicine classification of endometriosis: 1996, *Fertil Steril* 67:817, 1997.
388. **Damario MA, Rock JA**, Classification of endometriosis, *Semin Reprod Endocrinol* 15:235, 1997.
389. **Guzick DS, Silliman NP, Adamson GD, Buttram VC Jr, Canis M, Malinak LR, Schenken RS**, Prediction of pregnancy in infertile women based on the American Society for Reproductive Medicine's revised classification of endometriosis, *Fertil Steril* 67:822, 1997.
390. **Adamson GD, Pasta DJ**, Endometriosis fertility index: the new, validated endometriosis staging system, *Fertil Steril* 94(5):1609–1615, 2010.
391. **Roberts CP, Rock JA**, The current staging system for endometriosis: does it help? *Obstet Gynecol Clin North Am* 30:115, 2003.
392. **Tuttles F, Keckstein J, Ulrich U, Possover M, Schweppe KW, Wustlich M**, et al., ENZIAN-score, a classification of deep infiltrating endometriosis. (In German), *Zentralbl Gynakol* 127:275, 2005.
393. **Johnson NP, Hummelshoj L, Adamson GD, Keckstein J, Taylor HS, Abrao MS, Bush D, Kiesel L, Tamimi R, Sharpe-Timms KL, Rombauts L, Giudice LC**, World Endometriosis Society Sao Paulo

- Consortium; World Endometriosis Society consensus on the classification of endometriosis, *Hum Reprod* 32(2):315, 2017.
394. **Mahmood TA, Templeton A**, The impact of treatment on the natural history of endometriosis, *Hum Reprod* 5:965, 1990.
  395. **Gambone JC, Mittman BS, Munro MG, Scialli AR, Winkel CA**, Consensus statement for the management of chronic pelvic pain and endometriosis: proceedings of an expert-panel consensus process, *Fertil Steril* 78:961, 2002.
  396. **Brown J, Crawford TJ, Allen C, Hopewell S, Prentice A**, Nonsteroidal anti-inflammatory drugs for pain in women with endometriosis, *Cochrane Database Syst Rev* (1):CD004753, 2017.
  397. **Kistner RW**, Management of endometriosis in the infertile patient, *Fertil Steril* 26:1151, 1975.
  398. **Meresman GF, Vighi S, Buquet RA, Contreras-Ortiz O, Tesone M, Rumi LS**, Apoptosis and expression of Bcl-2 and Bax in eutopic endometrium from women with endometriosis, *Fertil Steril* 74:760, 2000.
  399. **Vercellini P, Somigliana E, Vigano P**, Endometriosis: current therapies and new pharmacological developments, *Drugs* 69:649, 2009.
  400. **Vercellini P, Frontino G, De Giorgi O, Pietropaolo G, Pasin R, Crosignani PG**, Continuous use of an oral contraceptive for endometriosis-associated recurrent dysmenorrhea that does not respond to a cyclic pill regimen, *Fertil Steril* 80:560, 2003.
  401. **Proctor ML, Roberts H, Farquhar CM**, Combined oral contraceptive pill (OCP) as treatment for primary dysmenorrhoea, *Cochrane Database Syst Rev* CD002120, 2001.
  402. **Harada T, Momoeda M, Taketani Y, Hoshiai H, Terakawa N**, Low-dose oral contraceptive pill for dysmenorrhea associated with endometriosis: a placebo-controlled, double-blind, randomized trial, *Fertil Steril* 90:1583, 2008.
  403. **Davis L, Kennedy SS, Moore J, Prentice A**, Modern combined oral contraceptives for pain associated with endometriosis, *Cochrane Database Syst Rev* CD001019, 2007.
  404. **Olive DL**, Medical therapy of endometriosis, *Semin Reprod Med* 21:209, 2003.
  405. **Moore J, Kennedy S, Prentice A**, Modern combined oral contraceptives for pain associated with endometriosis, *Cochrane Database Syst Rev* CD001019, 2000.
  406. **Vercellini P, Fedele L, Pietropaolo G, Frontino G, Somigliana E, Crosignani PG**, Progestogens for endometriosis: forward to the past, *Hum Reprod Update* 9:387, 2003.
  407. **Song JY, Fraser IS**, Effects of progestogens on human endometrium, *Obstet Gynecol Surv* 50:385, 1995.
  408. **Bruner KL, Eisenberg E, Gorstein F, Osteen KG**, Progesterone and transforming growth factor-beta coordinately regulate suppression of endometrial matrix metalloproteinases in a model of experimental endometriosis, *Steroids* 64:648, 1999.
  409. **Osteen KG, Igarashi TM, Bruner-Tran KL**, Progesterone action in the human endometrium: induction of a unique tissue environment which limits matrix metalloproteinase (MMP) expression, *Front Biosci* 8:d78, 2003.
  410. **Vercellini P, Cortesi I, Crosignani PG**, Progestins for symptomatic endometriosis: a critical analysis of the evidence, *Fertil Steril* 68:393, 1997.
  411. **Luciano AA, Turksoy RN, Carleo J**, Evaluation of oral medroxyprogesterone acetate in the treatment of endometriosis, *Obstet Gynecol* 72:323, 1988.
  412. **Telimaa S, Puolakka J, Ronnberg L, Kauppila A**, Placebo-controlled comparison of danazol and high-dose medroxyprogesterone acetate in the treatment of endometriosis, *Gynecol Endocrinol* 1:13, 1987.
  413. **Prentice A, Deary AJ, Bland E**, Progestagens and anti-progestagens for pain associated with endometriosis, *Cochrane Database Syst Rev* CD002122, 2000.
  414. **Crosignani PG, Luciano A, Ray A, Bergqvist A**, Subcutaneous depot medroxyprogesterone acetate versus leuprolide acetate in the treatment of endometriosis-associated pain, *Hum Reprod* 21:248, 2006.
  415. **Brown J, Kives S, Akhtar M**, Progestagens and anti-progestagens for pain associated with endometriosis. *Cochrane Database Syst Rev* (3):CD002122, 2012.
  416. **Muneyyirci-Delale O, Karacan M**, Effect of norethindrone acetate in the treatment of symptomatic endometriosis, *Int J Fertil Womens Med* 43:24, 1998.
  417. **Schlaff WD, Dugoff L, Damewood MD, Rock JA**, Megestrol acetate for treatment of endometriosis, *Obstet*

Gynecol 75:646, 1990.

418. **Vercellini P, Aimi G, Panazza S, De Giorgi O, Pesole A, Crosignani PG**, A levonorgestrel-releasing intrauterine system for the treatment of dysmenorrhea associated with endometriosis: a pilot study, *Fertil Steril* 72:505, 1999.
419. **Vercellini P, Frontino G, De Giorgi O, Aimi G, Zaina B, Crosignani PG**, Comparison of a levonorgestrel-releasing intrauterine device versus expectant management after conservative surgery for symptomatic endometriosis: a pilot study, *Fertil Steril* 80:305, 2003.
420. **Lockhat FB, Emembolu JO, Konje JC**, The efficacy, side-effects and continuation rates in women with symptomatic endometriosis undergoing treatment with an intra-uterine administered progestogen (levonorgestrel): a 3 year follow-up, *Hum Reprod* 20:789, 2005.
421. **Petta CA, Ferriani RA, Abrao MS, Hassan D, Rosa ESJC, Podgaec S, Bahamondes L**, Randomized clinical trial of a levonorgestrel-releasing intrauterine system and a depot GnRH analogue for the treatment of chronic pelvic pain in women with endometriosis, *Hum Reprod* 20:1993, 2005.
422. **Fedele L, Bianchi S, Zanconato G, Portuese A, Raffaelli R**, Use of a levonorgestrel-releasing intrauterine device in the treatment of rectovaginal endometriosis, *Fertil Steril* 75:485, 2001.
423. **Abou-Setta AM, Houston B, Al-Inany HG, Farquhar C**, Levonorgestrel-releasing intrauterine device (LNG-IUD) for symptomatic endometriosis following surgery. *Cochrane Database Syst Rev* (1):CD005072, 2013.
424. **Yisa SB, Okenwa AA, Husemeyer RP**, Treatment of pelvic endometriosis with etonogestrel subdermal implant (Implanon), *J Fam Plann Reprod Health Care* 31:67, 2005.
425. **Walch K, Unfried G, Huber J, Kurz C, van Trotsenburg M, Pernicka E, Wenzl R**, Implanon versus medroxyprogesterone acetate: effects on pain scores in patients with symptomatic endometriosis—a pilot study, *Contraception* 79:29, 2009.
426. **Strowitzki T, Marr J, Gerlinger C, Faustmann T, Seitz C**, Dienogest is as effective as leuprolide acetate in treating the painful symptoms of endometriosis: a 24-week, randomized, multicentre, open-label trial, *Hum Reprod* 25:633, 2010.
427. **Harada T**, et al., Dienogest is as effective as intranasal buserelin acetate for the relief of pain symptoms associated with endometriosis: a randomized, double-blind, multicenter, controlled trial, *Fertil Steril* 91:675, 2009.
428. **Hayashi A**, et al., Dienogest increases the progesterone receptor isoform B/A ratio in patients with ovarian endometriosis, *J Ovarian Res* 5:31, 2010.
429. **H. Al Kadri, S. Hassan, H.M. Al-Fozan**, et al., Hormone therapy for endometriosis and surgical menopause, *Cochrane Database Syst Rev* (1):CD005997, 2009.
430. **Hirvonen E, Malkonen M, Manninen V**, Effects of different progestogens on lipoproteins during postmenopausal therapy, *New Engl J Med* 304:560, 1981.
431. **Fahraeus L, Sydsjo A, Wallentin L**, Lipoprotein changes during treatment of pelvic endometriosis with medroxyprogesterone acetate, *Fertil Steril* 45:503, 1986.
432. **Cundy T, Farquhar CM, Cornish J, Reid IR**, Short-term effects of high dose oral medroxyprogesterone acetate on bone density in premenopausal women, *J Clin Endocrinol Metab* 81:1014, 1996.
433. **Meldrum DR**, Clinical management of endometriosis with luteinizing hormone-releasing hormone analogues, *Semin Reprod Endocrinol* 3:371, 1985.
434. **Lemay A, Sandow J, Bureau M, Maneux R, Fontaine J-Y, Merat P**, Prevention of follicular maturation in endometriosis by subcutaneous infusion of luteinizing hormone-releasing hormone agonist started in the luteal phase, *Fertil Steril* 49:410, 1988.
435. **Brown J, Pan A, Hart RJ**, Gonadotrophin-releasing hormone analogues for pain associated with endometriosis. *Cochrane Database of Systematic Reviews* 12, 2010. Art. No.: CD008475. doi: 10.1002/14651858.CD008475.pub2.
436. **Hornstein MD, Surrey ES, Weisberg GW, Casino LA**, Leuprolide acetate depot and hormonal add-back in endometriosis: a 12-month study. *Lupron Add-Back Study Group*, *Obstet Gynecol* 91:16, 1998.
437. **Dlugi AM, Miller JD, Knittle J**, Lupron depot (leuprolide acetate for depot suspension) in the treatment of endometriosis: a randomized, placebo-controlled, double-blind study. *Lupron Study Group*, *Fertil Steril* 54:419,

1990.

438. **Valimaki M, Nilsson CG, Roine R, Ylikorkala O**, Comparison between the effects of nafarelin and danazol on serum lipids and lipoproteins in patients with endometriosis, *J Clin Endocrinol Metab* 69:1097, 1989.
439. **Burry KA, Patton PE, Illingworth DR**, Metabolic changes during medical treatment of endometriosis: nafarelin acetate versus danazol, *Am J Obstet Gynecol* 160:1454, 1989.
440. **Barbieri RL**, Hormone treatment of endometriosis: the estrogen threshold hypothesis, *Am J Obstet Gynecol* 166:740, 1992.
441. **Chwalisz K, Surrey E, Stanczyk FZ**, The hormonal profile of norethindrone acetate: rationale for add-back therapy with gonadotropin-releasing hormone agonists in women with endometriosis, *Reprod Sci* 19(6):563, 2012.
442. **Friedman AJ, Hornstein MD**, Gonadotropin-releasing hormone agonist plus estrogen-progestin “add-back” therapy for endometriosis-related pelvic pain, *Fertil Steril* 60:236, 1993.
443. **Surrey ES**, Add-back therapy and gonadotropin-releasing hormone agonists in the treatment of patients with endometriosis: can a consensus be reached? Add-Back Consensus Working Group, *Fertil Steril* 71:420, 1999.
444. **Hurst BS, Gardner SC, Tucker KE, Awoniyi CA, Schlaff WD**, Delayed oral estradiol combined with leuprolide increases endometriosis-related pain, *JSL* 4:97, 2000.
445. **Surrey ES, Hornstein MD**, Prolonged GnRH agonist and add-back therapy for symptomatic endometriosis: long-term follow-up, *Obstet Gynecol* 99:709, 2002.
446. **Surrey ES, Judd HL**, Reduction of vasomotor symptoms and bone mineral density loss with combined norethindrone and long-acting gonadotropin-releasing hormone agonist therapy of symptomatic endometriosis: a prospective randomized trial, *J Clin Endocrinol Metab* 75:558, 1992.
447. **Makarainen L, Ronnberg L, Kauppila A**, Medroxyprogesterone acetate supplementation diminishes the hypoestrogenic side effects of gonadotropin-releasing hormone agonist without changing its efficacy in endometriosis, *Fertil Steril* 65:29, 1996.
448. **Edmonds DK, Howell R**, Can hormone replacement therapy be used during medical therapy of endometriosis? *Br J Obstet Gynaecol* 101(Suppl 10):24, 1994.
449. **Kiilholma P, Tuimala R, Kivinen S, Korhonen M, Hagman E**, Comparison of the gonadotropin-releasing hormone agonist goserelin acetate alone versus goserelin combined with estrogen-progestogen add-back therapy in the treatment of endometriosis, *Fertil Steril* 64:903, 1995.
450. **Moghissi KS, Schlaff WD, Olive DL, Skinner MA, Yin H**, Goserelin acetate (Zoladex) with or without hormone replacement therapy for the treatment of endometriosis, *Fertil Steril* 69:1056, 1998.
451. **The Nafarelin European Endometriosis Trial Group**, Nafarelin for endometriosis: a large-scale, danazol-controlled trial of efficacy and safety, with 1-year follow-up, *Fertil Steril* 57:514, 1992.
452. **Fedele L, Bianchi S, Boccione L, Di Nola G, Franchi D**, Buserelin acetate in the treatment of pelvic pain associated with minimal and mild endometriosis: a controlled study, *Fertil Steril* 59:516, 1993.
453. **Vercellini P, Trespidi L, Colombo A, Vendola N, Marchini M, Crosignani PG**, A gonadotropin-releasing hormone agonist versus a low-dose oral contraceptive for pelvic pain associated with endometriosis, *Fertil Steril* 60:75, 1993.
454. **Waller KG, Shaw RW**, Gonadotropin-releasing hormone analogues for the treatment of endometriosis: long-term follow-up, *Fertil Steril* 59:511, 1993.
455. **Gerhard I, Schindler AE, Buhler K, Winkler U, Meinen K, Mancarella D, Hoffmann G, Schussler B, Kimmig R, Kranzfelder D**, Treatment of endometriosis with leuprorelin acetate depot: a German multicentre study, *Clin Ther* 14(Suppl A):3, 1992.
456. **Henzl MR, Corson SL, Moghissi K, Buttram VC Jr, Berqvist C, Jacobson J**, Administration of nasal nafarelin as compared with oral danazol for endometriosis, *N Engl J Med* 318:485, 1988.
457. **Henzl MR, Kwei L**, Efficacy and safety of nafarelin in the treatment of endometriosis, *Am J Obstet Gynecol* 162:570, 1990.
458. **Rolland R, van der Heijden PF**, Nafarelin versus danazol in the treatment of endometriosis, *Am J Obstet Gynecol* 162:586, 1990.
459. **Kennedy SH, Williams IA, Brodrigg J, Barlow DH, Shaw RW**, A comparison of nafarelin acetate and

- danazol in the treatment of endometriosis, *Fertil Steril* 53:998, 1990.
460. **Shaw RW**, An open randomized comparative study of the effect of goserelin depot and danazol in the treatment of endometriosis. Zoladex Endometriosis Study Team, *Fertil Steril* 58:265, 1992.
  461. **Regidor PA, Regidor M, Schmidt M, Ruwe B, Lubben G, Fortig P, Kienle E, Schindler AE**, Prospective randomized study comparing the GnRH-agonist leuprorelin acetate and the gestagen lynestrenol in the treatment of severe endometriosis, *Gynecol Endocrinol* 15:202, 2001.
  462. **Batioglu S, Celikkanat H, Ugur M, Mollamahmutoglu L, Yesilyurt H, Kundakci M**, The use of GnRH agonists in the treatment of endometriomas with or without drainage, *J Pak Med Assoc* 46:30, 1996.
  463. **Prentice A, Deary AJ, Goldbeck-Wood S, Farquhar C, Smith SK**, Gonadotrophin-releasing hormone analogues for pain associated with endometriosis, *Cochrane Database Syst Rev* CD000346, 2000.
  464. **Taylor HS et al.**, Treatment of endometriosis-associated pain with elagolix, an oral GnRH antagonist, *N Engl J Med* 377(1):28–40, 2017. doi: 10.1056/NEJMoa1700089. Epub 2017 May 19.
  465. **Ng J et al.**, Dose-dependent suppression of gonadotropins and ovarian hormones by elagolix in healthy premenopausal women, *JCEM* 102(5), 2017.
  466. **Surrey et al.**, Long-term outcomes of elagolix in women with endometriosis: results from two extension studies, *Obstetrics and Gynecology*, 2018.
  467. **Barbieri RL, Evans S, Kistner RW**, Danazol in the treatment of endometriosis: analysis of 100 cases with a 4-year follow-up, *Fertil Steril* 37:737, 1982.
  468. **Barbieri RL, Canick JA, Makris A, Todd RB, Davies IJ, Ryan KJ**, Danazol inhibits steroidogenesis, *Fertil Steril* 28:809, 1977.
  469. **Barbieri RL, Osathanondh R, Ryan KJ**, Danazol inhibition of steroidogenesis in the human corpus luteum, *Obstet Gynecol* 57:722, 1981.
  470. **Floyd WS**, Danazol: endocrine and endometrial effects, *Int J Fertil* 25:75, 1980.
  471. **McGinley R, Casey JH**, Analysis of progesterone in unextracted serum: a method using danazol [17 alpha-pregn-4-en-20-yno(2, 3-d) isoxazol-17-ol] a blocker of steroid binding to proteins, *Steroids* 33:127, 1979.
  472. **Barbieri RL, Hornstein MD**, Medical therapy for endometriosis, In: Wilson EA, ed. *Endometriosis*, Alan R. Liss, Inc., New York, 1987, p. 111.
  473. **Selak V, Farquhar C, Prentice A, Singla A**, Danazol for pelvic pain associated with endometriosis, *Cochrane Database Syst Rev* CD000068, 2007.
  474. **Miller JD, Shaw RW, Casper RF, Rock JA, Thomas EJ, Dmowski WP, Surrey E, Malinak LR, Moghissi K**, Historical prospective cohort study of the recurrence of pain after discontinuation of treatment with danazol or a gonadotropin-releasing hormone agonist, *Fertil Steril* 70:293, 1998.
  475. **Dmowski WP, Cohen MR**, Treatment of endometriosis with an antigonadotropin, Danazol. A laparoscopic and histologic evaluation, *Obstet Gynecol* 46:147, 1975.
  476. **Buttram VC Jr, Reiter RC, Ward S**, Treatment of endometriosis with danazol: report of a 6-year prospective study, *Fertil Steril* 43:353, 1985.
  477. **Wheeler JM, Knittle JD, Miller JD**; for the **Lupron Endometriosis Study Group**, Depot leuprolide acetate versus danazol in the treatment of women with symptomatic endometriosis: a multicenter, double-blind randomized clinical trial. II. Assessment of safety, *Am J Obstet Gynecol* 169:26, 1993.
  478. **Buttram VC Jr, Belue JB, Reiter R**, Interim report a study of danazol for the treatment of endometriosis, *Fertil Steril* 37:478, 1982.
  479. **Quagliarello J, Alba Greco M**, Danazol and urogenital sinus formation in pregnancy, *Fertil Steril* 43:939, 1985.
  480. **Wardle PG, Whitehead MI, Mills RP**, Nonreversible and wide ranging vocal changes after treatment with danazol, *Br Med J* 287:946, 1983.
  481. **Mercaitis PA, Peaper RE, Schwartz PA**, Effect of danazol on vocal pitch: a case study, *Obstet Gynecol* 65:131, 1985.
  482. **Alvarado RG, Liu JY, Zwolak RM**, Danazol and limb-threatening arterial thrombosis: two case reports, *J Vasc Surg* 34:1123, 2001.
  483. **Dmowski WP, Kapetanakis E, Scommegna A**, Variable effects of danazol on endometriosis at 4 low-dose

levels, *Obstet Gynecol* 59:408, 1982.

484. **Vercellini P, Trespidi L, Panazza S, Bramante T, Mauro F, Crosignani PG**, Very low dose danazol for relief of endometriosis-associated pelvic pain: a pilot study, *Fertil Steril* 62:1136, 1994.
485. **Igarashi M, Iizuka M, Abe Y, Ibuki Y**, Novel vaginal danazol ring therapy for pelvic endometriosis, in particular deeply infiltrating endometriosis, *Hum Reprod* 13:1952, 1998.
486. **Igarashi M**, A new therapy for pelvic endometriosis and uterine adenomyosis: local effect of vaginal and intrauterine danazol application, *Asia Oceania J Obstet Gynaecol* 16:1, 1990.
487. **Razzi S, Luisi S, Calonaci F, Altomare A, Bocchi C, Petraglia F**, Efficacy of vaginal danazol treatment in women with recurrence deeply infiltrating endometriosis, *Fertil Steril* 88:789, 2007.
488. **Okamura Y, Suzuki J, Honda R, Hoba T, Katabuchi H, Okamura O**, Clinical outcome of vaginal danazol suppository use in women with pelvic endometriosis. *Fertil Steril* 90(Suppl 1):S486, 2008.
489. **Bhattacharya SM, Tolasaria A, Khan B**, Vaginal danazol for the treatment of endometriosis-related pelvic pain, *Int J Gynaecol Obstet* 115:294, 2011.
490. **Ferrero S, Tramalloni D, Venturini PL, Remorgida V**, Vaginal danazol for women with rectovaginal endometriosis and pain symptoms persisting after insertion of a levonorgestrel-releasing uterine device, *Int J Gynaecol Obstet* 113:116, 2011. doi:10.1016/j.ijgo.2010.11.015.
491. **Mizutani T, Nishiyama S, Amakawa I, Watanabe A, Nakamuro K, Terada N**, Danazol concentrations in ovary, uterus, and serum and their effect on the hypothalamic-pituitary-ovarian axis during vaginal administration of a danazol suppository, *Fertil Steril* 63:1184, 1995.
492. **Attar E, Bulun SE**, Aromatase inhibitors: the next generation of therapeutics for endometriosis?, *Fertil Steril* 85:1307, 2006.
493. **Pavone ME, Bulun SE**, Aromatase inhibitors for the treatment of endometriosis. *Fertil Steril* 98(6):1370, 2012.
494. **Razzi S, Fava A, Sartini A, De Simone S, Cobellis L, Petraglia F**, Treatment of severe recurrent endometriosis with an aromatase inhibitor in a young ovariectomised woman, *Br J Obstet Gynaecol* 111:182, 2004.
495. **Ailawadi RK, Jobanputra S, Kataria M, Gurates B, Bulun SE**, Treatment of endometriosis and chronic pelvic pain with letrozole and norethindrone acetate: a pilot study, *Fertil Steril* 81:290, 2004.
496. **Shippen ER, West WJ Jr**, Successful treatment of severe endometriosis in two premenopausal women with an aromatase inhibitor, *Fertil Steril* 81:1395, 2004.
497. **Amsterdam LL, Gentry W, Jobanputra S, Wolf M, Rubin SD, Bulun SE**, Anastrozole and oral contraceptives: a novel treatment for endometriosis, *Fertil Steril* 84:300, 2005.
498. **Hefler LA, Grimm C, van Trotsenburg M, Nagele F**, Role of the vaginally administered aromatase inhibitor anastrozole in women with rectovaginal endometriosis: a pilot study, *Fertil Steril* 84:1033, 2005.
499. **Fatemi HM, Al-Turki HA, Papanikolaou EG, Kosmas L, De Sutter P, Devroey P**, Successful treatment of an aggressive recurrent post-menopausal endometriosis with an aromatase inhibitor, *Reprod Biomed Online* 11:455, 2005.
500. **Ferrero S, Venturini PL, Ragni N, Camerini G, Remorgida V**, Pharmacological treatment of endometriosis: experience with aromatase inhibitors, *Drugs* 69(8):943, 2009.
501. **Soysal S, Soysal ME, Ozer S, Gul N, Gezgin T**, The effects of post-surgical administration of goserelin plus anastrozole compared to goserelin alone in patients with severe endometriosis: a prospective randomized trial, *Hum Reprod* 19:160, 2004.
502. **Ferrero S, Camerini G, Seracchioli R, Ragni N, Venturini PL, Remorgida V**, Letrozole combined with norethisterone acetate compared with norethisterone acetate alone in the treatment of pain symptoms caused by endometriosis, *Hum Reprod* 24:3033, 2009.
503. **Ferrero S, Camerini G, Ragni N, Venturini PL, Biscaldi E, Seracchioli R, et al.**, Letrozole and norethisterone acetate in colorectal endometriosis, *Eur J Obstet Gynecol Reprod Biol* 150:199, 2010.
504. **Remorgida V, Abbamonte HL, Ragni N, Fulcheri E, Ferrero S**, Letrozole and norethisterone acetate in rectovaginal endometriosis, *Fertil Steril* 88:724, 2007.
505. **Sasson IE, Taylor HS**, Aromatase inhibitor for treatment of a recurrent abdominal wall endometrioma in a

postmenopausal woman, *Fertil Steril* 92(3):1170.e1, 2009.

506. **Bedaiwy MA, Alfaraaj S, Yong P, Casper R**, New developments in the medical treatment of endometriosis, *Fertil Steril* 107(3):555, 2017.
507. **Kettel LM, Murphy AA, Morales AJ, Ulmann A, Baulieu EE, Yen SS**, Treatment of endometriosis with the antiprogestosterone mifepristone (RU486), *Fertil Steril* 65:23, 1996.
508. **Kettel LM, Murphy AA, Morales AJ, Yen SS**, Preliminary report on the treatment of endometriosis with low-dose mifepristone (RU 486), *Am J Obstet Gynecol* 178:1151, 1998.
509. **Kulak J Jr, Fischer C, Komm B, Taylor HS**, Treatment with bazedoxifene, a selective estrogen receptor modulator, causes regression of endometriosis in a mouse model. *Endocrinology* 152(8):3226, 2011.
510. **Naqvi H, Sakr S, Presti T, Krikun G, Komm B, Taylor HS**, Treatment with bazedoxifene and conjugated estrogens results in regression of endometriosis in a murine model, *Biol Reprod* 90(6):121, 2014.
511. **Flores VA, Stachenfeld NS, Taylor HS**, Bazedoxifene-conjugated estrogens for treating endometriosis, *Obstet Gynecol* 132(2):475, 2018.
512. **Hill AM, Lessey B, Flores VA, Taylor HS**, Bazedoxifene/conjugated estrogens in combination with leuprolide for the treatment of endometriosis, *Clin Case Rep* 6(6):990, 2018.
513. **Flores VA, Vanhie A, Dang T, Taylor HS**, Precision medicine in endometriosis: progesterone receptor status in endometriosis. *Journal of Clinical Endocrinology and Metabolism* 103(12):4561–4568, 2018. PMID 30357380.
514. **Taylor HS, Osteen KG, Bruner-Tran KL**, Novel therapies targeting endometriosis, *Reprod Sci* 18:814, 2011.
515. **Laschke M, Menger M**, Anti-angiogenic treatment strategies for the therapy of endometriosis, *Hum Reprod Update* 18:682, 2012.
516. **Sahin C, Mamillapalli R, Yi KW, Taylor HS**, microRNA Let-7b: a novel treatment for endometriosis, *J Cell Mol Med* 22(11):5346, 2018.
517. **Crosignani PG, Vercellini P, Biffignandi F, Costantini W, Cortesi I, Imperato E**, Laparoscopy versus laparotomy in conservative surgical treatment for severe endometriosis, *Fertil Steril* 66:706, 1996.
518. **Bruhat MA, Mage G, Chapron C, Pouly JL, Canis M, Wattiez A**, Present day endoscopic surgery in gynecology, *Eur J Obstet Gynecol Reprod Biol* 41:4, 1991.
519. **Adamson GD, Pasta DJ**, Surgical treatment of endometriosis-associated infertility: meta-analysis compared with survival analysis, *Am J Obstet Gynecol* 171:1488, 1994.
520. **Adamson D**, Surgical management of endometriosis, *Semin Reprod Med* 21:223, 2003.
521. **Duffy JM, Arambage K, Correa FJ, Olive D, Farquhar C, Garry R**, et al., Laparoscopic surgery for endometriosis. *Cochrane Database Syst Rev* (4):CD011031, 2014
522. **Kodaman PH**, Current strategies for endometriosis management, *Obstet Gynecol Clin North Am* 42(1):87, 2015.
523. **Koninckx PR, Martin D**, Treatment of deeply infiltrating endometriosis, *Curr Opin Obstet Gynecol* 6:231, 1994.
524. **Vercellini P, Frontino G, Pietropaolo G, Gattei U, Daguati R, Crosignani PG**, Deep endometriosis: definition, pathogenesis, and clinical management, *J Am Assoc Gynecol Laparosc* 11:153, 2004.
525. **Ferrero S, Alessandri F, Racca A, Leone Roberti Maggiore U**, Treatment of pain associated with deep endometriosis: alternatives and evidence, *Fertil Steril* 104(4):771, 2015.
526. **Donnez J, Smets M, Jadoul P, Pirard C, Squifflet J**, Laparoscopic management of peritoneal endometriosis, endometriotic cysts, and rectovaginal adenomyosis, *Ann N Y Acad Sci* 997:274, 2003.
527. **Hart RJ, Hickey M, Maouris P, Buckett W**, Excisional surgery versus ablative surgery for ovarian endometriomata, *Cochrane Database Syst Rev* (2):CD004992, 2008.
528. **Hart RJ, Hickey M, Maouris P, Buckett W, Garry R**, Excisional surgery versus ablative surgery for ovarian endometriomata, *Cochrane Database Syst Rev* CD004992, 2005.
529. **Muzii L, Bellati F, Palaia I, Plotti F, Mancini N, Zullo MA, Angioli R, Panici PB**, Laparoscopic stripping of endometriomas: a randomized trial on different surgical techniques. Part I: clinical results, *Hum Reprod* 20:1981, 2005.
530. **Raffi F, Metwally M, Amer S**, The impact of excision of ovarian endometrioma on ovarian reserve: a

systematic review and meta-analysis, *J Clin Endocrinol Metab* 97(9):3146, 2012.

531. **Reich H, Abrao MS**, Post-surgical ovarian failure after laparoscopic excision of bilateral endometriomas: is this rare problem preventable? *Am J Obstet Gynecol* 195:339, 2006.
532. **Wilson ML, Farquhar CM, Sinclair OJ, Johnson NP**, Surgical interruption of pelvic nerve pathways for primary and secondary dysmenorrhoea, *Cochrane Database Syst Rev* CD001896, 2000.
533. **Candiani GB, Fedele L, Vercellini P, Bianchi S, Di Nola G**, Presacral neurectomy for the treatment of pelvic pain associated with endometriosis: a controlled study, *Am J Obstet Gynecol* 167:100, 1992.
534. **Chen FP, Soong YK**, The efficacy and complications of laparoscopic presacral neurectomy in pelvic pain, *Obstet Gynecol* 90:974, 1997.
535. **Candiani GB, Fedele L, Vercellini P, Bianchi S, Di Nola G**, Repetitive conservative surgery for recurrence of endometriosis, *Obstet Gynecol* 77:421, 1991.
536. **Sutton CJG, Pooley AS, Ewen SP, Haines P**, Follow-up report on a randomized controlled trial of laser laparoscopy in the treatment of pelvic pain associated with minimal to moderate endometriosis, *Fertil Steril* 68:1070, 1997.
537. **Shakiba K, Bena JF, McGill KM, Minger J, Falcone T**, Surgical treatment of endometriosis: a 7-year follow-up on the requirement for further surgery, *Obstet Gynecol* 111:1285, 2008.
538. **Vercellini P, Viganò P, Somigliana E, Fedele L**, Endometriosis: pathogenesis and treatment, *Nat Rev Endocrinol* 10(5):261, 2014.
539. **Taylor E, Williams C**, Surgical treatment of endometriosis: location and patterns of disease at reoperation, *Fertil Steril* 93:57, 2010.
540. **Schweppe KW, Ring D**, Peritoneal defects and the development of endometriosis in relation to the timing of endoscopic surgery during the menstrual cycle, *Fertil Steril* 78:763, 2002.
541. **Namnoum AB, Hickman TN, Goodman SB, Gehlbach DL, Rock JA**, Incidence of symptom recurrence after hysterectomy for endometriosis, *Fertil Steril* 64:898, 1995.
542. **Matorras R, Elorriaga MA, Pijoan JI, Ramon O, Rodriguez-Escudero FJ**, Recurrence of endometriosis in women with bilateral adnexectomy (with or without total hysterectomy) who received hormone replacement therapy, *Fertil Steril* 77:303, 2002.
543. **Hickman TN, Namnoum AB, Hinton EL, Zacur HA, Rock JA**, Timing of estrogen replacement therapy following hysterectomy with oophorectomy for endometriosis, *Obstet Gynecol* 91:673, 1998.
544. **Rana N, Rotman C, Hasson HM, Redwine DB, Dmowski WP**, Ovarian remnant syndrome after laparoscopic hysterectomy and bilateral salpingo-oophorectomy for severe pelvic endometriosis, *J Am Assoc Gynecol Laparosc* 3:423, 1996.
545. **Clayton RD, Hawe JA, Love JC, Wilkinson N, Garry R**, Recurrent pain after hysterectomy and bilateral salpingo-oophorectomy for endometriosis: evaluation of laparoscopic excision of residual endometriosis, *Br J Obstet Gynaecol* 106:740, 1999.
546. **Dmowski WP, Radwanska E, Rana N**, Recurrent endometriosis following hysterectomy and oophorectomy: the role of residual ovarian fragments, *Int J Gynaecol Obstet* 26:93, 1988.
547. **Magtibay PM, Nyholm JL, Hernandez JL, Podratz KC**, Ovarian remnant syndrome, *Am J Obstet Gynecol* 193(6):2062, 2005.
548. **Furness S, Yap C, Farquhar C, Cheong YC**, Pre and post-operative medical therapy for endometriosis surgery, *Cochrane Database Syst Rev* (3):CD003678, 2004.
549. **Somigliana E, Vercellini P, Viganò P, Benaglia L, Busnelli A, Fedele L**, Postoperative medical therapy after surgical treatment of endometriosis: from adjuvant therapy to tertiary prevention. *J Minim Invasive Gynecol*, 21(3):328, 2014.
550. **Flower A, Liu JP, Lewith G, Little P, Li Q**, Chinese herbal medicine for endometriosis, *Cochrane Database Syst Rev* (5):CD006568, 2012.
551. **Hughes E, Brown J, Collins JJ, Farquhar C, Fedorkow DM, Vandekerckhove P**, Ovulation suppression for endometriosis, *Cochrane Database Syst Rev* CD000155, 2007.
552. **Sallam HN, Garcia-Velasco JA, Dias S, Arici A**, Long-term pituitary down-regulation before in vitro fertilization (IVF) for women with endometriosis. *Cochrane Database Syst Rev* (1):CD004635, 2006.



553. **Surrey ES, Silverberg KM, Surrey MW, Schoolcraft WB**, Effect of prolonged gonadotropin-releasing hormone agonist therapy on the outcome of in vitro fertilization-embryo transfer in patients with endometriosis, *Fertil Steril* 78(4):699, 2002.
554. **de Ziegler D, Gayet V, Aubriot FX**, Use of oral contraceptives in women with endometriosis before assisted reproduction treatment improves outcomes, *Fertil Steril* 94(7):2796, 2010.
555. **Gruppo Italiano per lo Studio Dell'Endometriosi**, Ablation of lesions or no treatment in minimal-mild endometriosis in infertile women: a randomized trial, *Hum Reprod* 14:1332, 1999.
556. **Wood C, Maher P, Hill D**, Diagnosis and surgical management of endometriomas, *Aust N Z J Obstet Gynaecol* 32:161, 1992.
557. **Reich H, McGlynn F**, Treatment of ovarian endometriomas using laparoscopic surgical techniques, *J Reprod Med* 31:577, 1986.
558. **Donnez J, Nisolle M, Gillet N, Smets M, Bassil S, Casanas-Roux F**, Large ovarian endometriomas, *Hum Reprod* 11:641, 1996.
559. **Practice Committee of the American Society for Reproductive Medicine; Pfeifer S, Fritz M, Goldberg J, McClure R, Lobo R, Thomas M, Widra E, Schattman G, Licht M, Collins J, Cedars M, Racowsky C, Vernon M, Davis O, Barnhart K, Gracia C, Catherino W, Rebar R, Barbera AL**, Endometriosis and infertility: a committee opinion, *Fertil Steril* 98(3):591, 2012.
560. **Busacca M, Bianchi M, Agnoli B**, et al., Follow-up of laparoscopic treatment of stage IIIIV endometriosis, *J Am Assoc Gynecol Laparosc* 6:55, 1999.
561. **Soong YK, Chang FH, Chou HH**, et al., Life table analysis of pregnancy rates in women with moderate or severe endometriosis comparing danazol therapy after carbon dioxide laser laparoscopy plus electrocoagulation or laparotomy plus electrocoagulation versus danazol therapy only, *J Am Assoc Gynecol Laparosc* 4:225, 1997.
562. **Bianchi PH, Pereira RM, Zanatta A, Alegratti JR, Motta EL, Serafini PC**, Extensive excision of deep infiltrative endometriosis before in vitro fertilization significantly improves pregnancy rates, *J Minim Invasive Gynecol* 16:174, 2009.
563. **Farquhar C, Vandekerckhove P, Watson A, Vail A, Wiseman D**, Barrier agents for preventing adhesions after surgery for subfertility, *Cochrane Database Syst Rev* CD000475, 2000.
564. **Watson A, Vandekerckhove P, Lilford R**, Liquid and fluid agents for preventing adhesions after surgery for subfertility, *Cochrane Database Syst Rev* CD001298, 2003.
565. **Alderman MH III, Yoder N, Taylor HS**, The systemic effects of endometriosis, *Semin Reprod Med* 35(3):263, 2017.
566. **Goetz LG, Mamillapalli R, Taylor HS**, Low body mass index in endometriosis is promoted by hepatic metabolic gene dysregulation in mice, *Biol Reprod* 95(6):115, 2016.
567. **Mu F, Rich-Edwards J, Rimm EB, Spiegelman D, Missmer SA**, Endometriosis and risk of coronary heart disease, *Circ Cardiovasc Qual Outcomes* 9(3):257, 2016.
568. **Pluchino, Wenger, Petignat P, Tal R, Bolmont M, Taylor HS, Bianchi-De micheli F**, Sexual function in endometriosis patients and their partners: effect of the disease and consequences of treatment, *Hum Reprod Update* 22(6):762, 2016.

---

# Ectopic Pregnancy

Ectopic pregnancy remains an important cause of maternal morbidity and mortality. However, because modern diagnostic methods now permit early recognition of most ectopic pregnancies, contemporary treatments are more conservative than in the past. The focus of attention has shifted from emergency surgery for the control of life-threatening hemorrhage to medical treatments aimed at avoiding surgery and preserving reproductive anatomy and retaining potential for future fertility. This chapter will review the history, epidemiology, and pathogenesis of ectopic pregnancy and discuss current methods for diagnosis and treatment.

# HISTORY OF ECTOPIC PREGNANCY

---

The modern management of ectopic pregnancy is arguably one of medicine's greatest success stories. Ectopic pregnancy was first described in the 11th century and, for centuries thereafter, often was a fatal complication of pregnancy. In medieval times, ectopic implantation was viewed as the consequence of violent emotion, usually fright or surprise, experienced during coitus in the cycle of conception.<sup>1</sup> The first documented unruptured ectopic pregnancy was described in the results of an autopsy performed on a female prisoner condemned to death and executed in 1693. Ectopic pregnancy and infertility were first linked in 1752, when an extrauterine pregnancy was reported in an infertile sex worker. By the mid-19th century, autopsy observations had raised suspicion that ectopic pregnancy might be related to pelvic infection.

Early treatments were designed to kill the ectopic conceptus and included starvation, purging, bleeding, and even use of strychnine. Attempts to destroy the abnormally located gestation by passing electrical current into an ectopic gestational sac were made often with ensuing sepsis and death. Isolated reports of abdominal surgical procedures in women with ectopic pregnancies first appeared in the early 17th century, but not again until more than 100 years later. The first known surgical procedure for ectopic pregnancy was performed in France, in 1714. In the United States, John Bard of New York (1759) and William Baynham of Virginia (1791) were the first to perform abdominal surgery for ectopic pregnancy.<sup>1</sup> However, during the first 80 years of the 18th century, only 5 of 30 women who underwent abdominal surgery for ectopic pregnancy survived; those not treated had a greater chance for survival (1 in 3)!

In 1849, W.W. Harbert of Kentucky was the first to suggest early surgical intervention to stop fatal hemorrhage.<sup>2</sup> Unfortunately, the diagnosis of ruptured ectopic pregnancy came too late for most. In 1876, John Parry of Philadelphia aptly described the prognosis for women with ectopic pregnancy in his era<sup>3</sup>:

...when one is called to a case of this kind, it is his duty to look upon his unhappy patient as inevitably doomed to die, unless he can by some active measure wrest her from the grave already yawning before her.

After witnessing the death and autopsy of several women with ectopic pregnancies, Robert Lawson Tait of London discovered the source and means to control hemorrhage in women with ruptured ectopic pregnancies and performed the first deliberate laparotomy to ligate bleeding vessels in 1884.<sup>4</sup> Within little more than a year, Tait accumulated a relatively large and successful experience with the procedure.

Over subsequent years, the advent of aseptic techniques, anesthesia, antibiotics, and blood transfusions combined to save the lives of many women; however, fatalities remained common due to late diagnosis and delayed intervention. Even during the first half of the 20th century, maternal mortality from ectopic pregnancy in the United States was between 2% and 4%. Although immediate salpingectomy and blood transfusion dramatically improved outcomes in women with ectopic pregnancy, the impact of modern methods for diagnosis and treatment developed over the last 30 years has been far greater. Even in the developed world, as recently as the 1970s, almost 15% of women with ectopic pregnancies presented in hypovolemic shock; by the early 1980s, these occurrences were down to fewer than 5%, allowing health care providers to focus on strategies aimed at preserving fertility.

# EPIDEMIOLOGY OF ECTOPIC PREGNANCY

---

The incidence of ectopic pregnancy is approximately 1.5–2% of all pregnancies. The incidence increased dramatically, by about sixfold, between 1970 and 1992. At the same time, the risk of death related to ectopic pregnancy decreased by almost 90% (from 35.5 to 3.8 deaths/10,000 ectopic pregnancies).<sup>5</sup> In 1989, less than 2% of all pregnancies were ectopic, but related complications accounted for 4–10% of all pregnancy-related deaths and were **the** leading cause of maternal death during the first trimester.<sup>5,6</sup> Recognizing the increasing trend toward outpatient surgical and medical management of ectopic pregnancy,<sup>7,8,9</sup> the Centers for Disease Control and Prevention, in 1992, combined data from the National Hospital Discharge Survey and the National Hospital Ambulatory Medical Care Survey and estimated the incidence of ectopic pregnancy at 19.7/1,000 reported pregnancies.<sup>6</sup>

Efforts to determine accurately more recent trends in the incidence of ectopic pregnancy have proven very difficult, because the numbers of ectopic pregnancies managed in the outpatient setting (not captured in hospital discharge surveys) and involving multiple health care visits (confounding data from ambulatory care surveys) have increased dramatically.<sup>10</sup> Moreover, the incidence of ectopic pregnancy is expressed as the number of ectopic pregnancies per 1,000 pregnancies, but pregnancies not resulting in delivery or hospitalization are not counted; furthermore, the vast majority of failed pregnancies now are managed entirely in the outpatient setting. Nonetheless, available evidence suggests that the incidence of ectopic pregnancy is relatively stable.<sup>11,12,13</sup> Whereas the use of ovulation-inducing drugs and assisted reproductive technologies (ARTs) has increased significantly in recent years (both are known risk factors for ectopic pregnancy) and contemporary methods permit more accurate and earlier diagnosis than in the past (resulting in fewer ectopic pregnancies escaping detection in those with access to health care), advances in detection and treatment of sexually transmitted infections have, at the same time, also helped to minimize sequelae of undiagnosed and untreated infection-related damage to the fallopian tubes (a major risk factor for ectopic pregnancy).<sup>12,14,15</sup>

Racial and socioeconomic disparities in the incidence of ectopic pregnancy are recognized. Ectopic pregnancy rates are higher among minorities than in whites and are also higher in socioeconomically disadvantaged populations, in all age groups. For all races, ectopic pregnancy rate increases progressively with age and is 3–4 times higher for women aged 35–44 than for those aged 15–24.<sup>5,16,17</sup>

# Risk Factors

Although many women with ectopic pregnancies have one or more recognized risk factors (Table 33.1), almost half of all diagnosed with an ectopic pregnancy have none.<sup>18,19,20</sup> A comprehensive analysis of case-control and cohort studies, using women with intrauterine pregnancies or nonpregnant women as controls, has helped to define their relative importance.<sup>21,22,23</sup>

## TABLE 33.1

Medical History	Prior ectopic pregnancy STIs: Gonorrhea, chlamydia Genital tuberculosis History of infertility
Developmental	In utero DES exposure Salpingitis isthmica nodosa (SIN)
Environmental	Smoking Alcohol consumption ( $\geq 10$ g daily) Early initiation of oral hormonal contraceptives (age < 16)
Surgical History	Tubal ligation Tubal surgery (salpingostomy, fimbrioplasty, tubal recannulation) Postoperative adhesions from pelvic surgery
Iatrogenic	Intrauterine contraceptive device use

**Risk for ectopic pregnancy is increased as much as 10-fold for women with a previous ectopic pregnancy compared to the general population.** The overall risk for recurrence is approximately 15%, reflecting both the underlying tubal pathology that led to the first ectopic pregnancy and the damage or trauma resulting from its treatment. Data from several studies indicate that the overall risk of recurrence is approximately 10% for women with one previous ectopic pregnancy and at least 25% for women having two or more.<sup>12,24,25,26,27,28</sup> In a study comparing the recurrence risks associated with medical and surgical treatment for previous ectopic pregnancy, the risk of recurrence was approximately 8% after medical treatment with methotrexate (single-dose regimen), 10% after a salpingectomy, and 15% after a linear salpingostomy.<sup>29</sup> Approximately 60% of women who have an ectopic pregnancy will subsequently

achieve a successful intrauterine pregnancy.<sup>28,30,31</sup>

**Risk for ectopic pregnancy is increased at least threefold for women with documented tubal pathology.**<sup>21,22,32</sup> In most cases, the damage results from sexually transmitted infections, gonorrhea and chlamydia being the most common. Salpingitis damages the endosalpingeal mucosa, causing agglutination of mucosal folds and intraluminal adhesions that may entrap a migrating embryo, leading to ectopic implantation. Risk for ectopic pregnancy is increased twofold for women with circulating chlamydia antibodies, and the majority of women with ectopic pregnancies have high levels.<sup>33,34,35,36</sup> In a retrospective cohort study of women with previous documented chlamydia infection, the risk of hospitalization for ectopic pregnancy was increased more than twofold for women with two previous infections and more than fourfold for those having three or more.<sup>37</sup> Overall, women with surgically documented salpingitis have a fourfold increased risk of ectopic pregnancy; the risk is approximately 10% after one episode of pelvic infection and increases progressively with each subsequent infection.<sup>38</sup>

**Risk for ectopic pregnancy is increased at least twofold for women exposed to diethylstilbestrol (DES) in utero.**<sup>21,39,40</sup> Numerous abnormalities of tubal anatomy have been observed in DES-exposed women, including shortened and convoluted tubes, constricted fimbria, and paratubal cysts,<sup>41,42</sup> but whether such abnormalities relate directly to the increased risk for ectopic pregnancy is unknown. DES was banned from future use in 1971 after its association with vaginal clear cell adenocarcinoma was recognized,<sup>43</sup> but the youngest DES-exposed women are still in their late reproductive years and occasionally may be encountered.

**The incidence and absolute risk of ectopic pregnancy are reduced with all methods of contraception.**<sup>44,45,46</sup> For any method, the ectopic pregnancy rate (pregnancy rate multiplied by the proportion of pregnancies with ectopic implantation) is lower than for women using no contraception (2.6 ectopic pregnancies/1,000 women-years). Among the most common methods of contraception, estrogen-progestin contraceptives and vasectomy are associated with the lowest absolute incidence of ectopic pregnancy (0.005 ectopic pregnancies/1,000 women-years). Rates are still very low, but about 60 times higher for tubal sterilization (0.32/1,000 women-years) and 200 times higher for the intrauterine device (IUD; 1.02/1,000 women-years).<sup>45,46,47</sup> The risk for ectopic pregnancy in women who conceive while using barrier methods or oral contraceptives is no different than in pregnant controls.<sup>46</sup>

Most of the available data relating to the risk of ectopic pregnancy associated with the IUD derive from older studies involving IUDs no longer in use.<sup>22,48</sup> Only two IUDs



currently are marketed in the United States, a copper-bearing device and the levonorgestrel intrauterine system (LNG-IUS). Both are highly effective in preventing intrauterine and ectopic pregnancy with cumulative 5-year pregnancy rates that compare favorably with those observed in women after tubal sterilization (0.5–1%).<sup>49,50,51,52,53,54</sup> **However, if pregnancy does occur with an IUD in situ, the risk for ectopic pregnancy is as high as 53%.**<sup>55,56</sup> Logically, the IUD should be expected to protect better against intrauterine than extrauterine implantation. Consequently, a greater proportion of pregnancies that occur will be ectopic. In one study of outcomes in 64 documented pregnancies in women with a LNG-IUS, one-half were ectopic.<sup>55</sup>

The U.S. Collaborative Review of Sterilization, involving more than 10,000 women who had a tubal sterilization, found that the 10-year cumulative probability of pregnancy after sterilization was 18.5/1,000 procedures.<sup>57</sup> **Data from the same cohort and others indicate that approximately one-third of all pregnancies resulting from sterilization failure are ectopic.**<sup>58,59,60</sup> The overall 10-year cumulative risk of ectopic pregnancy after tubal sterilization is approximately 7.3/1,000 procedures, but the risk varies with the surgical method. Bipolar coagulation is associated with the highest risk (17.1/1,000 procedures) and postpartum partial salpingectomy with the lowest (1.5/1,000 procedures). For all methods other than postpartum partial salpingectomy, the probability of ectopic pregnancy is greater for women sterilized under age 30 than for older women. The 10-year cumulative probability of ectopic pregnancy for women sterilized by bipolar coagulation before age 30 (31.9/1,000 procedures) is more than 25 times the rate for postpartum partial salpingectomy at any age, which might be attributed to an increased incidence of tuboperitoneal fistula at the distal end of the proximal tubal segment. For all methods combined, only about 20% of pregnancies occurring within 3 years after tubal sterilization are ectopic, but more than 60% of those occurring after 4 or more years are ectopic pregnancies.<sup>58,59,60,61</sup>

Ectopic pregnancies have been reported following emergency oral contraception. The best available evidence indicates that emergency contraception acts primarily by preventing or delaying ovulation or by preventing fertilization, rather than by inhibiting implantation. In theory, progestational agents may inhibit tubal motility and predispose to ectopic implantation, but none of the emergency oral contraceptive regimens in use appears to increase the risk.<sup>62,63,64,65</sup>

Although the assumption is that women without a uterus cannot conceive, a recent systematic review identified 57 reported cases of tubal ectopic pregnancies in hysterectomized women.<sup>66</sup> Thus, in the setting of a typical presentation concerning for ectopic pregnancy, a pregnancy test should be obtained in all women regardless of hysterectomy status.<sup>66</sup>

**Risk for ectopic pregnancy is increased approximately twofold for infertile women.**<sup>21,67,68,69,70,71</sup> The association between infertility and previous pelvic infection and tubal pathology offers one obvious explanation. Ovulation-inducing drugs also are associated with increased risk, but whether unrecognized coexisting tubal factors or altered tubal function in stimulated cycles may be responsible is unclear.<sup>32,68,72</sup>

**The risk of ectopic pregnancy may be increased as much as twofold in women who conceive with the use of ART.**<sup>73,74</sup> Indeed, it is interesting to remember that the first pregnancy achieved with in vitro fertilization (IVF) and embryo transfer was ectopic.<sup>75</sup> Although the mechanisms responsible have not been defined, spontaneous retrograde migration of the embryo(s) transferred within the uterine cavity into the tube and inadvertent direct tubal embryo transfer are logical considerations to explain occurrence of tubal ectopic pregnancy following intrauterine embryo transfer. Women with tubal factor infertility or those with a history of a previous ectopic pregnancy are at the highest risk for such an event following IVF-embryo transfer. However, risk is increased even among women without obvious tubal damage.<sup>12</sup> It is possible that the nonphysiologic hormone milieu of IVF cycles that is characterized by elevated estradiol and progesterone hormone levels may adversely affect tubal transport function.<sup>72,76</sup> This latter impression is strengthened by recent data identifying that unlike fresh IVF-embryo transfer cycles, the incidence of ectopic pregnancy is no higher in thawed embryo transfer IVF cycles.<sup>77</sup> Higher volumes of transfer media or deep catheter insertion into the uterine cavity may predispose to accidental tubal transfer.<sup>73,78,79</sup> Technically difficult transfers have been identified as another independent risk factor.<sup>80</sup> Heterotopic pregnancies, in which one or more embryos implant both in the uterus and elsewhere, are rare in naturally conceived pregnancies (approximately 1 in 4,000–10,000 pregnancies), but far more common in infertile women who conceive after ovulation induction or IVF.<sup>74,81,82,83</sup> A meta-analysis from 2017 demonstrated that day 5 embryo transfer was associated with lower risk of ectopic pregnancy than day 3 (relative risk 0.67; 95% confidence interval, 0.54–0.85; 143,643 pregnancies in 23 studies).<sup>84</sup> Data from the U.S. ART registry suggest that the risk of ectopic pregnancy associated with ART has decreased in recent years and now is no greater than in naturally conceived pregnancies; in 2007, only 0.7% of pregnancies resulting from ART using fresh nondonor oocytes or embryos were ectopic pregnancies.<sup>85</sup>

Tubal anastomosis surgery has been offered to women with history of tubal sterilization as an alternative to IVF. With a pooled pregnancy rate of 42–69%, tubal reversal procedures are associated with increased risk of ectopic pregnancy (4–8% of all conceptions).<sup>86</sup>

**Overall, the risk for ectopic pregnancy is increased approximately twofold**

**among women who smoke.** Compared to never-smokers, the risk is increased by approximately 50% for past and light smokers (one to nine cigarettes daily) and rises progressively with heavier daily consumption.<sup>22,87</sup> Studies in animals suggest that the mechanism responsible may involve a lower efficiency of oocyte-cumulus complex capture or a decreased tubal ciliary beat frequency induced by chemical components of cigarette smoke.<sup>88,89</sup> Relationship between alcohol consumption and ectopic pregnancy has also been suggested. There is no evidence to indicate any relationship between ectopic pregnancy and exposure to other chemical or physical agents.<sup>90</sup>

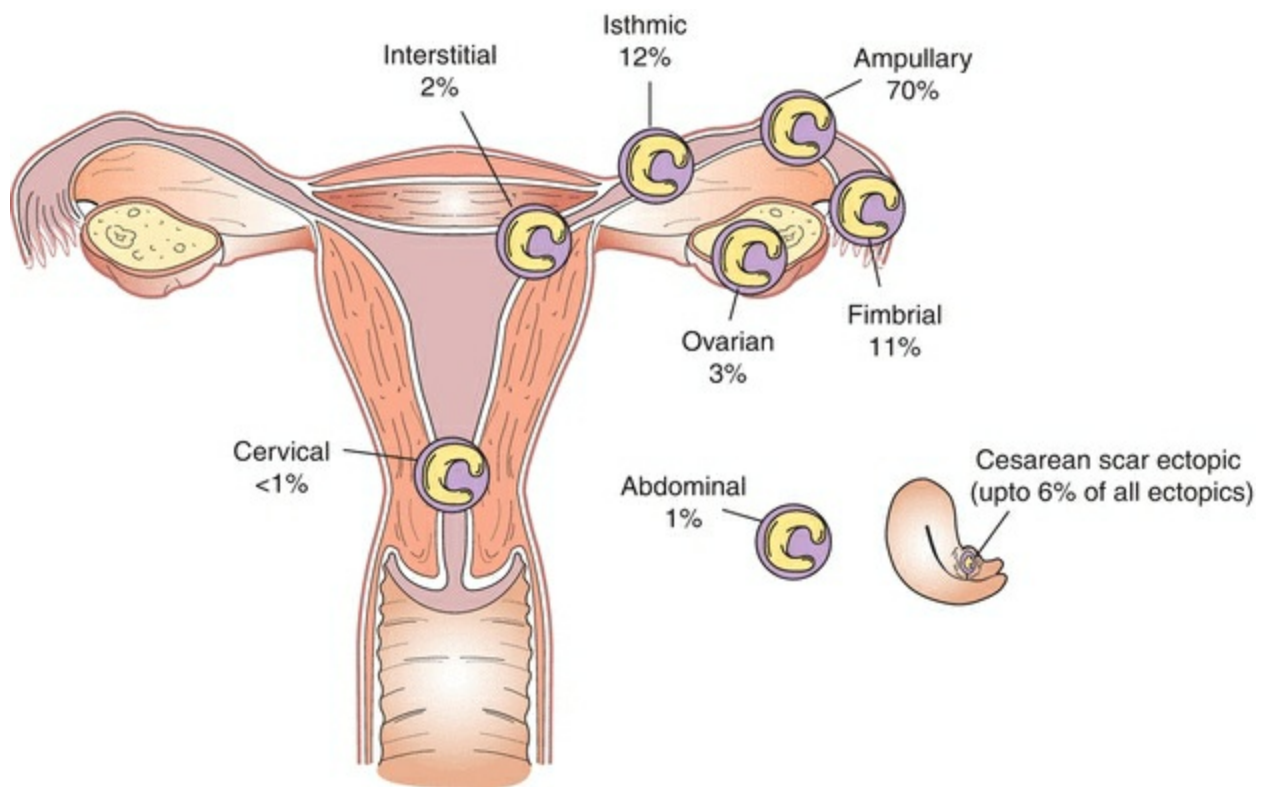
**Early age at first intercourse, number of lifelong sexual partners, and early initiation of hormonal contraceptives are described to associate with a mildly increased risk of ectopic pregnancy, presumably because of the higher probability of exposure to sexually transmitted infections.**<sup>21,22,91</sup> Numerous studies have found an association between vaginal douching and ectopic pregnancy.<sup>92,93,94,95,96,97</sup> Understandably, most have attributed the observation to an associated increased risk of ascending infection, but others have suggested that women with symptoms of genital infection are simply more likely to douche<sup>98</sup>; a causal relationship between douching and ectopic pregnancy has not been established.

An increased risk of ectopic pregnancy is described in patients with female genital tuberculosis, and this relationship merits consideration in at-risk populations.<sup>99</sup> Crohn disease (but not ulcerative colitis) has also been associated with increased risk of ectopic pregnancy.<sup>100</sup>

Salpingitis isthmica nodosa (SIN), first described by an Austrian pathologist Hans Chiari in 1887, is a recognized risk factor for recurrent ectopic pregnancy.<sup>101</sup> Gross appearance of the involved specimen is classic with one or more areas of nodular thickening involving the isthmic portion of the tube. Etiology for SIN remains unclear.

# PATHOGENESIS OF ECTOPIC IMPLANTATION

The fallopian tube is by far the most common site of ectopic implantation, accounting for more than 98% of all ectopic pregnancies. Overall, 70% of ectopic pregnancies are located in the tubal ampulla, 12% in the isthmus, 11% in the fimbria, and 2% in the interstitial (cornual) segment (Figure 33.1).<sup>102,103</sup> Ectopic pregnancies in sites other than the fallopian tubes are relatively rare and can involve the ovary, cervix, and cesarean scar and abdominal sites.<sup>102,103</sup>



**FIGURE 33.1**

Anything that interferes with normal tubal transport mechanisms may predispose to ectopic pregnancy. It is possible, but unproven, that endocrine factors predisposing to premature implantation also may contribute to the pathogenesis of ectopic pregnancy.<sup>104</sup> In histopathologic studies, postinflammatory changes (chronic salpingitis and SIN) have been observed in up to 90% of fallopian tubes excised for ectopic pregnancy.<sup>105,106,107</sup> Other abnormalities have included diverticula and foci of persistent decidual transformation. Any such underlying tubal pathology remains after conservative

treatments, medical or surgical, and may predispose to recurrence. The ectopic implantation itself may further damage the tube, depending on the extent of trophoblastic invasion. The endometrium in women with ectopic pregnancies usually exhibits decidual change, but also can have secretory or even proliferative histologic characteristics.<sup>108</sup>

The histopathology of ectopic pregnancies varies with the site of implantation. In approximately half of ampullary ectopic pregnancies, trophoblastic proliferation occurs entirely within the tubal lumen and the muscularis remains intact.<sup>109</sup> In the remainder, the trophoblast penetrates the tubal wall and proliferates in the loose connective tissue between the muscularis and the serosa.<sup>109,110,111</sup> In most cases, the characteristic segmental dilation of the tubal ampulla is composed mostly of coagulated blood rather than trophoblastic tissue. In contrast, ectopic implantations in the tubal isthmus typically penetrate the tubal wall relatively early,<sup>109</sup> probably because the more muscular segment is less distensible. All ectopic pregnancies are not destined to rupture. In fact, many will resolve without intervention, presumably by spontaneous regression in situ or tubal abortion (expulsion via the fimbria).<sup>112</sup>

A number of studies have suggested that the prevalence of chromosomal abnormalities is increased in ectopic pregnancies and that intrinsic genetic abnormalities might in some way predispose to extrauterine implantation. However, more careful studies have failed to corroborate this phenomenon.<sup>113</sup> In fact, the prevalence of chromosomal aberrations among ectopic pregnancies appears almost identical to that expected (approximately 5%) when maternal and gestational age are considered.<sup>103,113,114,115</sup>

# DIAGNOSIS OF ECTOPIC PREGNANCY

---

Ectopic pregnancy is associated with a classic triad of symptoms—delayed menses, vaginal bleeding, and lower abdominal pain—observed in women with both ruptured and unruptured ectopic pregnancies. In a series of 147 patients with ectopic pregnancy, the clinical presentation included abdominal pain in 99%, amenorrhea in 74%, and vaginal bleeding in 56%.<sup>116</sup> Unfortunately, there are no physical findings unique to ectopic pregnancy; similar symptoms are observed commonly in women with failing intrauterine pregnancies.<sup>117,118</sup> Symptoms that should alert clinicians to the possibility of a ruptured ectopic pregnancy include shoulder pain (from irritation of the diaphragm by blood in the peritoneal cavity), light-headedness, and features of shock (from severe intra-abdominal hemorrhage). Thankfully, the symptoms associated with advanced or ruptured ectopic pregnancy now are seldom seen, because most women present with mild pain or vaginal spotting well before tubal rupture and are identified promptly using methods that are more sensitive and specific than in the past.

Clinical suspicion, based on an awareness of risk factors and the early symptoms of ectopic pregnancy, is the key to identifying women who merit prompt and careful evaluation. **The ready availability of highly sensitive and specific assays for the  $\beta$ -subunit of human chorionic gonadotropin (hCG) has narrowed the differential diagnosis of ectopic pregnancy to include only pregnancy-related problems, including threatened, missed, complete, and incomplete abortions.** In almost all women, one or more serum  $\beta$ -hCG determinations and transvaginal ultrasonography can establish or exclude the diagnosis of ectopic pregnancy within a short time, if not immediately. Serum progesterone measurements and uterine curettage (only when an early viable intrauterine pregnancy can be confidently excluded) also can be informative. Laparoscopy remains an important management option but rarely is any longer necessary for diagnosis alone in clinically stable patients.

Numerous diagnostic algorithms have been proposed for women suspected of having an ectopic pregnancy. All are based on the same basic concepts. Outpatient evaluation has been shown to be safe and effective for establishing a diagnosis of viable or nonviable intrauterine pregnancy or ectopic pregnancy. Accurate diagnosis is important because management of the three conditions is distinctly different.

# The Serum $\beta$ -hCG Concentration

hCG is secreted by the syncytiotrophoblast and becomes detectable in maternal serum as early as 8–10 days after ovulation in normal conception cycles. At or near the time of the first missed menses, serum levels between 50 and 100 IU/L are typical. Modern assays for the  $\beta$ -subunit of hCG are highly specific and sensitive, with detection limits below 5 IU/L. Consequently, virtually all women with suspected ectopic pregnancy who are not truly pregnant will have a negative test (no detectable hormone). False-negative tests are quite rare but, in the past, have been described in women with documented ectopic pregnancies.<sup>119,120,121</sup> False-positive tests are equally rare and most often result from endogenous heterophilic antibodies, which bind to the animal antibodies (mouse, rabbit, goat) used in commercial immunometric assay systems and thereby mimic hCG immunoreactivity.<sup>122,123,124,125</sup>

**Although rare, heterophilic antibodies are important to understand and to recognize because persistent false-positive tests may be misinterpreted as evidence of ectopic pregnancy or gestational trophoblastic disease and lead to inappropriate evaluation and treatments having potential for serious consequences.**<sup>122</sup> A false-positive serum hCG usually remains at the same level over time, neither increasing or decreasing. When the clinical presentation is uncertain or inconsistent with the test result, a true-positive hCG can be confirmed by (1) obtaining a similar result with a different assay method, (2) demonstrating hCG in the urine, and (3) obtaining parallel results with serial dilutions of the hCG standard and the patient's serum.

**Serum  $\beta$ -hCG concentrations rise predictably, at an exponential pace, during the early weeks of normal intrauterine pregnancy. In general, levels double every 1.4–2.1 days in early pregnancy and peak between 50,000 and 100,000 IU/L at 8–10 weeks of gestation.**<sup>126,127,128</sup> The rate of rise slows gradually as gestational age advances and  $\beta$ -hCG concentrations increase,<sup>128</sup> but during the brief interval when diagnosis of ectopic pregnancy is most important (from 2 to 5 weeks after ovulation), the pattern is close to linear. Evidence from studies performed before 1990 indicated that  $\beta$ -hCG levels should increase at least 66% every 2 days at concentrations below 10,000 IU/L in viable early intrauterine pregnancies, that few normal pregnancies (3–10%) ever exhibit an abnormal pattern, and that most of those do so only transiently.<sup>126,127,129,130</sup> However, in a more recent and careful analysis of data derived from evaluation of 287 women presenting with pain or bleeding and nondiagnostic ultrasonography who ultimately proved to have viable intrauterine pregnancies, the slowest or minimal rise observed was 24% after 1 day and 53% after 2 days.<sup>131</sup> The median rise in  $\beta$ -hCG levels was 50% after 1 day, 124% after 2 days, and 400% after 4

days. A recent retrospective cohort study demonstrated that hCG rise was faster when initial hCG level was lower and slower when presenting hCG was high. The study included 285 women initially diagnosed with pregnancy of unknown location who subsequently had a confirmed viable intrauterine pregnancy. For initial hCG values of less than 1,500, 1,500–3,000 and greater than 3,000 mIU/mL, the predicted 2-day minimal rise was found to be 49%, 40%, and 33%, respectively. Notably, African American women had a faster hCG rise compared to non–African American women.<sup>132</sup>

**Overall, existing data indicate that compared to the pattern observed in viable intrauterine pregnancies,  $\beta$ -hCG levels increase at a slower rate in most, but not all, ectopic and nonviable intrauterine pregnancies.<sup>126,133</sup> Thus, when encountering a suboptimal rise in serum hCG levels, high level of suspicion for an ectopic pregnancy must be maintained. Also notable is that the minimal normal increase in  $\beta$ -hCG concentrations for women with a viable intrauterine pregnancy (50% over 2 days) is “slower” than previously reported. Therefore, when following suspected ectopic pregnancy, a level of vigilance regarding possibility of a normal intrauterine gestation is needed and should be considered in decision-making to diagnose and treat abnormal pregnancies.<sup>131</sup>**

In an analysis of data derived from evaluation of 200 women presenting to an emergency department who ultimately proved to have ectopic pregnancies, the median rise in serum  $\beta$ -hCG levels was 25% over 2 days, with 60% of patients having an increase and 40% exhibiting a decrease in  $\beta$ -hCG concentrations over that interval.<sup>133</sup> Among those with rising levels, the mean increase (75% over 2 days) was smaller than the average for women with viable intrauterine pregnancies, and among those with declining concentrations, the decrease (27% over 2 days) was smaller than the average for women with completed spontaneous abortions. However, in 21% of women with ectopic pregnancies, the rise in  $\beta$ -hCG levels was greater than or equal to the minimal rise defined for women with viable intrauterine pregnancies, and in 8% of women with declining levels, the decrease was similar to that in women with completed spontaneous abortions.<sup>133</sup> When levels do not rise normally, or fall, the pregnancy is almost certainly not viable, but may be ectopic or intrauterine. Serum hCG concentrations generally fall more rapidly in spontaneous abortions than in ectopic pregnancies, but the rate of decrease varies with the initial  $\beta$ -hCG concentration and is slower when levels are lower<sup>134</sup>; overall, a decrease of less than 21% after 2 days or 60% after 7 days suggests retained products of conception or an ectopic pregnancy. **Normally rising (>50% over 2 days) or rapidly falling (>20% over 2 days)  $\beta$ -hCG concentrations generally are reassuring, but do not exclude the possibility of ectopic pregnancy.**<sup>133,135,136</sup>

In a woman with a pregnancy of unknown location whose hCG level is more than 2,000 mIU/mL, the most likely diagnosis is a nonviable intrauterine pregnancy,



occurring approximately twice as often as ectopic pregnancy. Ectopic pregnancy, in turn, occurs approximately 19 times as often as a viable intrauterine pregnancy when the hCG level is 2,000–3,000 mIU/mL in the absence of evidence of an intrauterine gestation on transvaginal ultrasound and 70 times as often as a viable intrauterine pregnancy when the hCG level is more than 3,000 mIU/mL in the absence of sonographic evidence of an intrauterine gestation.<sup>137</sup>

**When the risk of multiple gestation is relatively high, as in pregnancies resulting from ovarian stimulation or IVF, serial serum  $\beta$ -hCG determinations are more difficult to interpret confidently because the usual standards established for naturally conceived singleton pregnancies may not apply.**<sup>138</sup> In most multiple pregnancies,  $\beta$ -hCG levels are higher than in singleton gestations of the same age, reflecting the combined contributions of all gestations; the rate of hCG rise, however, should remain within the described norms.<sup>139</sup> However, spontaneous pregnancy reductions are common in multiple gestations,<sup>140</sup> and heterotopic pregnancies are not altogether rare in women conceiving following ART.<sup>74,82</sup> One or more normally progressing intrauterine gestations may produce normal or increased levels of hCG, but a coexisting failing intrauterine or ectopic gestation likely will not. The  $\beta$ -hCG level at any one point in time will reflect the sum contributions from all gestations, normal and abnormal, intrauterine and ectopic. The normal hCG production from a viable intrauterine pregnancy easily can obscure the abnormally small contribution from another abnormal gestation. Alternatively, falling levels of hCG production from an ill-fated intrauterine or ectopic gestation may yield a slower than expected increase in serum concentrations even though a coexisting viable intrauterine gestation is progressing normally.

It also is important to note that interassay variation in  $\beta$ -hCG measurements ranges between 10% and 15% in most laboratories. Consequently, for most confident interpretation, serial concentrations should be performed in the same laboratory whenever possible. Alert to all possible scenarios, serum  $\beta$ -hCG concentrations must be interpreted cautiously. **In sum, paired serum hCG concentrations alone cannot reliably distinguish ectopic pregnancies from abnormal or even normal intrauterine pregnancies. Consequently, the diagnostic evaluation of women with suspected ectopic pregnancy also must include transvaginal ultrasonography.**

# Transvaginal Ultrasonography

Numerous studies have helped to define the ultrasonographic characteristics of normal and abnormal early pregnancies.<sup>141,142,143,144,145,146,147,148,149,150</sup> An intrauterine gestational sac is the first ultrasonographic landmark in an early intrauterine pregnancy. The sac consists of a sonolucent center with a thick echogenic ring, formed by the surrounding decidual reaction. Modern high-frequency transducers (>5 MHz) can detect a gestational sac earlier than older, lower-frequency probes.<sup>151,152</sup> **Today, in pregnancies at gestation of 5.5 weeks or greater, transvaginal ultrasonography should identify a viable intrauterine pregnancy with almost 100% accuracy.**<sup>153,154,155</sup> The absence of an intrauterine gestational sac 38 days or more after onset of menses or 24 days after conception is strong presumptive evidence for a nonviable pregnancy (ectopic or intrauterine).<sup>156</sup> The criterion is useful when the menstrual history is well documented or conception occurs under close observation, but has little practical value when broadly applied, because irregular bleeding so often confounds attempts to define gestational age.<sup>157</sup>

When ultrasonography reveals no obvious intrauterine pregnancy, careful examination of the adnexal regions and cul-de-sac can provide additional useful information. **Observation of a gestational sac with a yolk sac, embryo, or cardiac activity outside of the uterus establishes the diagnosis of ectopic pregnancy and justifies immediate treatment.** Evidence of an extrauterine gestation can be identified in up to 80–90% of ectopic pregnancies.<sup>150,154,158,159,160</sup> A complex adnexal mass (not a simple cyst) or fluid in the cul-de-sac increases the probability of ectopic pregnancy but does not, by itself, make the diagnosis or justify immediate treatment.<sup>161,162</sup> Any other result is simply inconclusive. Some have suggested that measurements of endometrial thickness have predictive value because the endometrium is thinner in women with ectopic pregnancy than in those with viable or nonviable intrauterine pregnancies.<sup>163</sup> However, others have observed wide variations in endometrial thickness among women with suspected ectopic pregnancy or differences are too small to have clinical utility.<sup>157,164</sup> In a study involving 576 women presenting to an emergency department with complaints of pain and/or bleeding, the mean endometrial thickness was  $9.56 \pm 4.87$  mm for women with ectopic pregnancies,  $12.12 \pm 6.0$  mm for those with intrauterine pregnancies, and  $10.19 \pm 6.10$  mm for women with spontaneous abortions.<sup>165</sup> Although the extent of overlap among groups makes endometrial thickness a poor diagnostic test, a thickness greater than 21 mm with no evidence of an intrauterine gestational sac excludes ectopic pregnancy with 96% specificity.<sup>165</sup>

In many cases, transvaginal ultrasonography alone can establish the diagnosis in women with suspected ectopic pregnancies by revealing either an intrauterine or an

extrauterine gestational sac. In the emergency room or other acute setting, ultrasonography is diagnostic in 70–90% of women with suspected ectopic pregnancy.<sup>15,148,149,153,155,166,167</sup> While transvaginal sonography is an excellent method for diagnosis of ectopic pregnancy, tubal rupture, a well-known life-threatening complication of tubal pregnancy, cannot be reliably predicted with ultrasound. In a retrospective cohort study, the researchers reviewed 231 sonograms of women with sonographic diagnosis of ectopic pregnancies. Surgery was performed in 143 cases, and tubal rupture was diagnosed in 36 patients. They concluded that neither sonographic findings nor hCG levels correlated with tubal rupture.<sup>168</sup>

The diagnosis of ectopic pregnancy can be challenging. **When neither an intrauterine nor an extrauterine gestational sac is observed, defining a “pregnancy of unknown location,” the possibilities include an early intrauterine pregnancy in which the gestational sac has not yet developed or is collapsed, an intrauterine pregnancy that has completely aborted, or an ectopic pregnancy that is too small to be detected or one that has aborted.** In some cases, uterine anomalies, fibroids, or a hydrosalpinx can obscure an intrauterine or extrauterine pregnancy; obesity also can prevent confident sonographic interpretation. **Overall, at least 25% of women with an ectopic pregnancy present first with a pregnancy of unknown location,<sup>15,149,167</sup> and in 7–20% of women with that initial diagnosis, the location of pregnancy is eventually proven to be ectopic.<sup>149</sup>**

When available, color and pulsed Doppler ultrasonography can improve diagnostic accuracy. A small intrauterine gestational sac sometimes can be difficult to distinguish from the “pseudosac” (blood in the uterine cavity) observed in approximately 10% of women with ectopic pregnancy.<sup>169</sup> The local vascular changes associated with a true gestational sac can help to differentiate the two.<sup>170,171</sup> Vascular pulses and arterial flow velocity increase in early intrauterine pregnancy. The extent of peritrophoblastic arterial flow correlates with gestational sac size and serum  $\beta$ -hCG concentrations. Blood flow in the arteries of the fallopian tube containing an ectopic pregnancy is 20–40% greater than that in the contralateral tube.<sup>171,172</sup> Similarly, adnexal masses may be distinguished by the characteristics of blood flow surrounding them. For example, the resistive index of ectopic pregnancies also is higher than for corpus luteum cysts.<sup>173</sup> However, the method has numerous diagnostic pitfalls and requires substantial technical expertise, and use of standard transvaginal ultrasonography and serum  $\beta$ -hCG concentrations usually is sufficient.<sup>174</sup>

When ultrasonography is inconclusive, serum  $\beta$ -hCG concentrations can serve as a surrogate marker for gestational age and help determine whether an intrauterine gestational sac should or should not be present. The concept of a “discriminatory zone,”

the minimum serum  $\beta$ -hCG concentration above which a gestational sac always should be detected in a viable intrauterine pregnancy, revolutionized the diagnostic approach to suspected ectopic pregnancy. When the concept was first introduced in 1981, transabdominal ultrasonography was the standard and the discriminatory zone for  $\beta$ -hCG was at 6,000–6,500 IU/L.<sup>175</sup> **With the development of endovaginal transducers of higher frequency, the discriminatory zone decreased progressively and now generally ranges between 1,500 and 3,000 IU/L but may be as high as 3,500 IU/L in some institutions.**<sup>28,162,176,177,178</sup> In one study, 185 of 188 intrauterine pregnancies (98%) among women with a  $\beta$ -hCG concentration greater than 1,500 IU/L were imaged.<sup>15</sup> **In any given center, the discriminatory zone or value will depend on the experience of the examiner and on the type of equipment in use.**<sup>162,176,177</sup> **Using a higher, more conservative threshold value (e.g., 2,500 or even 3,500 IU/L) helps to minimize the risk of diagnostic error but also may delay diagnosis of an ectopic pregnancy.** A threshold value of 2,000 IU/L is suggested in the algorithm appearing in this chapter. Identification of an intrauterine gestational sac excludes the diagnosis of ectopic pregnancy, except in circumstances wherein a heterotopic pregnancy or a pregnancy in a rudimentary uterine horn must be considered.

When the  $\beta$ -hCG concentration is clearly above the discriminatory value in the absence of ultrasound evidence of an intrauterine gestation, attention should focus on establishing the location of the pregnancy that is now deemed as nonviable.<sup>28,148,179</sup> **The absence of an intrauterine gestational sac is a strong, but not conclusive, evidence for an ectopic pregnancy.**<sup>15</sup> Other possibilities must be considered before treatment begins. In incomplete abortions, an intrauterine gestational sac may be absent or difficult to recognize. In very recent complete abortions, serum  $\beta$ -hCG levels may be declining rapidly, but still elevated above the threshold. Even a viable intrauterine pregnancy cannot be excluded entirely when there is good reason to suspect a multiple gestation. **Consequently, even when the  $\beta$ -hCG concentration is above the discriminatory value, a repeated  $\beta$ -hCG measurement in 1–2 days merits consideration in women at low risk for ectopic pregnancy with few or no symptoms, to identify those who might otherwise receive unnecessary treatment, or worse, harmful treatment.** A rapidly falling  $\beta$ -hCG level indicates a resolving nonviable pregnancy and can be followed until undetectable. A normally rising  $\beta$ -hCG concentration indicates the need for repeated ultrasonography to exclude the possibility of a viable intrauterine pregnancy not detected previously and that otherwise might result in inadvertent termination of a desired pregnancy or in severe embryopathy due to exposure to methotrexate (intrauterine growth restriction, microcephaly, and facial, cranial, and skeletal abnormalities).<sup>180,181,182,183,184,185</sup>

In patients with initial  $\beta$ -hCG values below the discriminatory zone, the absence of

an intrauterine gestational sac is inconclusive; clinical signs (hemodynamic instability), symptoms (pain), and other sonographic findings (extrauterine gestational sac, complex adnexal mass, cul-de-sac fluid) must guide clinical management.<sup>186</sup> In some women, clinical circumstances will demand an immediate and definitive surgical diagnosis. Women with no or few symptoms require close follow-up and serial evaluations until the possibility of ectopic pregnancy can be excluded.<sup>153,162,187,188</sup> Repeated measurements of serum  $\beta$ -hCG at 2-day intervals help to distinguish nonviable pregnancies from early viable intrauterine gestations not yet large enough to be detected at initial ultrasound evaluation.

**In women with normally increasing  $\beta$ -hCG levels below the discriminatory value, ultrasonography should be performed or repeated when levels have risen above the discriminatory value.** After 2–7 days, ultrasonography can be expected to demonstrate the location of the pregnancy in the large majority of cases.<sup>149</sup> Occasionally, a new adnexal abnormality (complex mass) or increasing clinical symptoms may demand a definitive surgical diagnosis.<sup>162,187,188</sup> **Women with rapidly decreasing  $\beta$ -hCG concentrations and absence of symptoms warrant only continued observation because the likelihood of an underlying ectopic pregnancy progressing to rupture is low.**<sup>189</sup> Nonetheless, serial measurements should be obtained until levels are no longer detectable, which can take up to as much as 6 weeks.<sup>12</sup> Those in whom an intrauterine pregnancy has not been documented remain at risk for rupture of an ectopic pregnancy until  $\beta$ -hCG is no longer detectable.<sup>153</sup> **Slowly declining or abnormally rising  $\beta$ -hCG levels indicate a nonviable pregnancy that still may be ectopic or intrauterine, but virtually exclude the possibility of a viable intrauterine pregnancy. The same is true when  $\beta$ -hCG levels rise to a concentration clearly above the discriminatory value and ultrasonography is again inconclusive (no intrauterine or extrauterine gestational sac). In either case, medical treatment could be offered safely, but a presumed diagnosis of ectopic pregnancy will be inaccurate, and treatment unnecessary, in up to 40% of women.**<sup>190</sup> Therefore, many prefer to perform uterine curettage to distinguish the remaining two possibilities (discussed below).

**A conservative approach to pregnancies of unknown location prevents inappropriate intervention in the setting of a viable intrauterine pregnancy.** Although it risks a modest delay in diagnosis of ectopic pregnancy and a small possibility of rupture, evidence from several studies indicates that a conservative diagnostic approach rarely compromises the care of women with pregnancies of unknown location.<sup>155,167,187,191,192,193,194,195</sup> Consequently, every reasonable effort should be made to establish a definite diagnosis.

# Serum Progesterone Concentration

Serum progesterone concentrations generally are lower in ectopic pregnancies than in viable intrauterine pregnancies.<sup>196,197,198,199</sup> The most logical explanation is that ectopic pregnancies are almost always accompanied by abnormally low levels of  $\beta$ -hCG production. Whereas the  $\beta$ -hCG secreted by ectopic gestations is chemically and biologically indistinct from that in intrauterine pregnancies,<sup>200,201</sup> production rates are lower, primarily because ectopic trophoblast proliferates more slowly and is less biologically active.<sup>202,203</sup> Corpus luteum progesterone production in early pregnancy is regulated primarily by the rate of change in serum hCG concentrations.<sup>201</sup> Under normal circumstances, the exponential increase in hCG levels ensures that LH/hCG receptors are occupied to the extent corresponding with maximal stimulation as the corpus luteum matures and the number of available receptors increases. In contrast, few ectopic pregnancies exhibit normal hCG production rates for very long. Consequently, progesterone secretion may increase normally at first but inevitably slows, resulting in lower serum concentrations.<sup>204,205</sup> There is no evidence to support the alternative hypothesis that poor luteal function in ectopic pregnancy results from reduced or absent production of other trophic fetoplacental factors distinct from hCG.<sup>201</sup>

**Serum progesterone levels associated with early normal and abnormal intrauterine pregnancies and ectopic pregnancies vary widely and overlap to a large extent.** Consequently, whereas a grossly low serum progesterone concentration is unlikely to be associated with a viable intrauterine pregnancy, it cannot distinguish an ectopic pregnancy from a failed intrauterine gestation.<sup>9,14,206,207,208,209,210</sup> **The probability of a viable intrauterine pregnancy increases with higher serum progesterone concentration.** Levels greater than 20 ng/mL almost always indicate a normal intrauterine pregnancy. Conversely, concentrations less than 5 ng/mL almost always indicate a nonviable pregnancy, which may be either ectopic or intrauterine.<sup>9,14</sup> Unfortunately, 50% of ectopic pregnancies, nearly 20% of spontaneous abortions, and almost 70% of viable intrauterine pregnancies are associated with serum progesterone levels **between** 5 and 20 ng/mL.<sup>211,212</sup> Moreover, because exceptions to the norm can and do occur, neither threshold value is entirely reliable in an individual woman. Only about 0.3% of women with viable intrauterine pregnancies have a serum progesterone level under 5 ng/mL, but approximately 3% of those with ectopic pregnancies have progesterone concentrations above 20 ng/mL.<sup>207,212</sup> The utility of serum progesterone measurements in the evaluation of women with suspected ectopic pregnancy is further limited when conception results from treatments involving ovarian stimulation strategies. Higher than usual progesterone levels logically may be expected because treatment often yields more than a single corpus luteum.<sup>213</sup>

Some have suggested that progesterone levels less than 5 ng/mL identify women in whom uterine curettage can be performed safely in search of chorionic villi to distinguish ectopic pregnancies from spontaneous abortions.<sup>9,214</sup> Using that approach, the probability of inappropriate intervention in a viable intrauterine pregnancy is indeed very low, but even that small risk may be unacceptably high. **In sum, serum progesterone measurements generally add very little to the diagnostic evaluation of women suspected of having an ectopic pregnancy.**

# Uterine Curettage

When ultrasonography is inconclusive and  $\beta$ -hCG concentrations are above the discriminatory zone, or below the threshold value, and rise abnormally, plateau, or fall, the possibility of a viable intrauterine pregnancy is all but excluded; an early multiple pregnancy and an error in performing or interpreting ultrasonography are the only exceptions. **Uterine curettage or office vacuum aspiration can help to distinguish ectopic from nonviable intrauterine pregnancies, but still should be applied selectively.** Uterine sampling clearly is inappropriate when there is any possibility of interrupting a viable intrauterine pregnancy and is unnecessary in women with rapidly falling  $\beta$ -hCG levels. **Recovery of chorionic villi from curetted or aspirated tissue excludes ectopic but not heterotopic pregnancy.** The absence of villi makes the diagnosis of ectopic pregnancy likely, although a very recent complete abortion or a technical failure to obtain or to recognize villi is possible; chorionic villi are not detected by histopathology in 20% of elective terminations of pregnancy.<sup>215</sup> **If uterine sampling is not performed and ectopic pregnancy is presumed, misdiagnosis leading to unnecessary treatment will occur in approximately 40% of women.**<sup>190</sup> **Therefore, uterine curettage or vacuum aspiration is recommended for women with nonviable pregnancies of unknown location, to distinguish an ectopic pregnancy that requires additional treatment from a nonviable intrauterine pregnancy that does not.**

If chorionic villi are present in the curetted or aspirated tissue, gross inspection of the sample in saline will reveal obvious villi about half of the time. If chorionic villi are found, the failed intrauterine pregnancy is confirmed and no further evaluation is necessary. Frozen section and histologic examination will demonstrate villi in 80–90% of specimens obtained from women with spontaneous abortion, and is recommended when available, to help avoid delays in establishing a definite diagnosis. Otherwise, a postprocedure serum  $\beta$ -hCG may be obtained. A 20% or greater decrease in the  $\beta$ -hCG level within 12–24 hours suggests strongly that the patient had a nonviable intrauterine gestation that was removed.<sup>215,216</sup> Conversely, a slower rate of decrease, or an increase, strongly suggests an ectopic pregnancy.<sup>12</sup> Women with declining levels can be monitored with serial  $\beta$ -hCG concentrations until no longer detectable or until the pathology report confirms the presence of chorionic villi. In a series of 111 women with nonviable pregnancies of unknown location that had curettage, villi were detected in 37% overall and in 51% of those whose initial  $\beta$ -hCG level was greater than 1,500 IU/L.<sup>190</sup>

Uterine curettage is costly, requires an operating room and anesthesia in some institutions, and is associated with a small risk of a complication. By comparison, uterine aspiration using a pipelle is simple to perform in the outpatient setting and



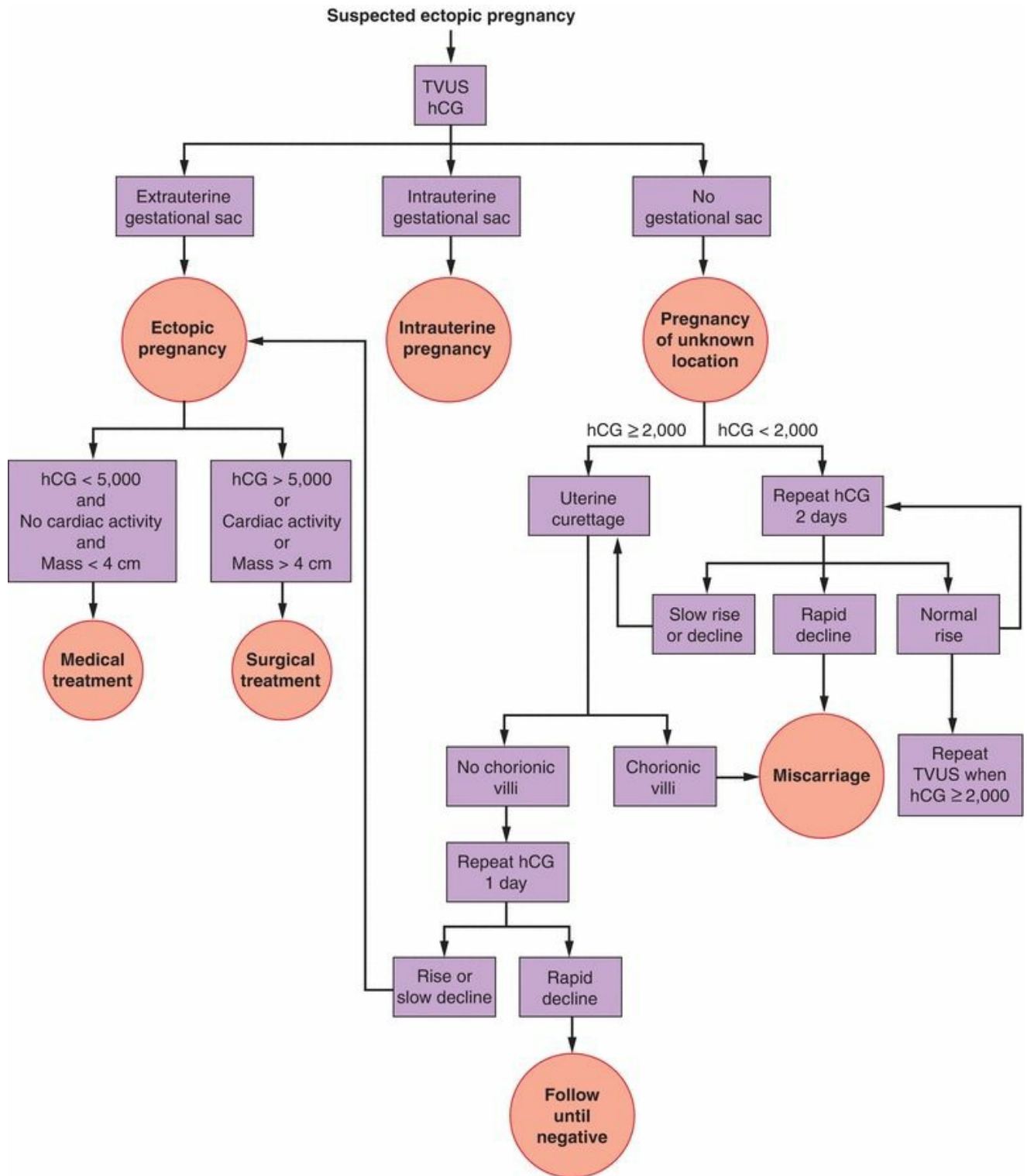
minimally invasive. The results obtained with pipelle aspiration and curettage generally correlate extremely well when they are performed for suspected endometrial pathology (hyperplasia or carcinoma). **Unfortunately, pipelle biopsy is not an effective substitute for curettage in the evaluation of women with suspected ectopic pregnancy. The sensitivity of pipelle biopsy for detecting chorionic villi is unacceptably poor, ranging between 30% and 60%.**<sup>217,218</sup> If treatment is based on results obtained with a pipelle biopsy, up to one in three women with a miscarriage may receive unnecessary and inappropriate medical or surgical treatment. The higher sensitivity of curettage (80–90%) yields a misdiagnosis of ectopic pregnancy in no more than approximately 2 in 10 women with a spontaneous abortion.<sup>218,219,220</sup> Manual vacuum aspiration has emerged as a safe and effective method for surgical abortion in early pregnancy (up to 12–14 weeks),<sup>221,222</sup> and it is now recommended as a preferred method for uterine sampling to diagnose the presence of chorionic villi in cases when abnormal intrauterine pregnancy cannot be distinguished from ectopic pregnancy by sonographic features.<sup>223,224</sup> Although rare, it is useful to remember that chorionic villi sometimes may be found in curettings from women with an ectopic pregnancy.<sup>225</sup>

Some advocate empiric medical treatment for all women with nonviable pregnancies of unknown location, viewing treatment as more practical and less invasive than curettage.<sup>193,226</sup> **A decision analysis found neither approach superior, but also observed that empiric treatment yields little savings, does not reduce complications, and clouds the prognosis for future fertility and the risk of repeat ectopic pregnancy.**<sup>227</sup> We favor uterine aspiration over empiric medical treatment, preferring to avoid unnecessary treatment and the uncertainties that result from a presumptive diagnosis of ectopic pregnancy.

# SCREENING FOR ECTOPIC PREGNANCY

---

Transvaginal ultrasonography and serum  $\beta$ -hCG determinations have proven diagnostic value in the evaluation of symptomatic women with suspected ectopic pregnancy (**Figure 33.2**). Not surprisingly, some have advocated applying the same diagnostic tools to screen asymptomatic women at increased risk for ectopic pregnancy. In practice, women at risk might be instructed to contact their clinician as soon as pregnancy is suspected and, if confirmed, receive careful monitoring with serial  $\beta$ -hCG determinations and timely ultrasonography. The alternative is to evaluate only those in whom clinical symptoms of pain or vaginal bleeding emerge. The rationale for screening at-risk women is that early diagnosis of ectopic pregnancy allows early intervention and noninvasive treatment that may help to minimize tubal damage and to reduce costs.<sup>228,229</sup> However, widespread screening of symptom-free women is costly and increases the likelihood of false-positive diagnoses of ectopic pregnancy that may result in unnecessary or inappropriate medical or surgical treatment.<sup>229,230</sup>



**FIGURE 33.2**

From both a clinical and economic perspective, the cost-effectiveness of screening depends on the prevalence or risk of ectopic pregnancy in the population chosen for screening. If the risk is low, very few ruptured ectopic pregnancies will be prevented, and the costs of screening far exceed the benefits and savings resulting from early

diagnosis and medical instead of surgical treatment. If uterine curettage is performed for all nonviable pregnancies identified through screening, the costs are even greater because the large majority will be spontaneous abortions that otherwise might be managed expectantly.<sup>230,231,232,233</sup> If the risk is high, the benefits and savings realized through prevention of ruptured ectopic pregnancies are proportionately greater and better justify the costs associated with screening.

**Results of a decision analysis suggest that screening probably is justified when the risk of ectopic pregnancy is approximately 8% or higher.** At that risk level, screening may be expected to prevent one to two ruptured ectopic pregnancies and to yield less than one false-positive diagnosis for every 100 women screened.<sup>230</sup> **Accepting a 2% background rate of ectopic pregnancy and considering the increased incidence associated with certain risk factors, screening seems justified for women with previous tubal surgery or prior ectopic pregnancy and those with known tubal pathology or who conceive with an IUD in situ or after a sterilization procedure or in those with a history of pelvic inflammatory disease.**

# EXPECTANT MANAGEMENT OF ECTOPIC PREGNANCY

---

If untreated, an ectopic pregnancy may end in tubal abortion, regress spontaneously, or progress to result in tubal rupture. Unfortunately, the outcome cannot be predicted reliably. Because the risk of tubal rupture and potential associated morbidity and mortality are significant, almost all women with a diagnosis of ectopic pregnancy receive medical or surgical treatment. However, in selected women, expectant management of a presumed ectopic pregnancy is an option with a reasonably high probability for success.<sup>234,235</sup>

Expectant management in the setting of a presumed ectopic pregnancy includes careful surveillance of clinical symptoms, serial monitoring, repeat assessments of serum  $\beta$ -hCG concentrations, and transvaginal ultrasonography. In essence, expectant management is identical to the diagnostic approach recommended for women with suspected ectopic pregnancy in whom ultrasonography is inconclusive and  $\beta$ -hCG levels are below the discriminatory zone.

**In the absence of any significant change in clinical status, women with known or presumed ectopic pregnancies can be observed as long as  $\beta$ -hCG levels are steadily decreasing.** Overall, approximately 25% of ectopic pregnancies are associated with declining  $\beta$ -hCG concentrations, and almost 70% of these (about 18% of all ectopic pregnancies) will resolve spontaneously without medical or surgical treatment.<sup>195,235,236</sup> The likelihood of success with expectant management is high when there is no demonstrable extrauterine gestational sac and  $\beta$ -hCG levels are relatively low.<sup>235,236</sup> When the baseline  $\beta$ -hCG concentration is less than 1,000 IU/L and falling, almost 90% of ectopic pregnancies regress without treatment.<sup>237</sup> Expectant management succeeds in 60% of women with decreasing  $\beta$ -hCG concentrations under 2,000 IU/L, but fails in over 90% with higher baseline  $\beta$ -hCG levels.<sup>236</sup>

A randomized clinical trial involving expectant management of women with known or suspected ectopic pregnancy involved 60 women who received either oral methotrexate (2.5 mg daily for 5 days) or placebo.<sup>238</sup> The mean  $\beta$ -hCG concentrations in the two groups were comparable. In both groups, 77% of patients were managed successfully without surgery, over an interval of less than 4 weeks. Given the absence of evidence that oral methotrexate treatment is effective, it is perhaps not surprising that outcomes in the two groups were similar. Another placebo-controlled randomized trial enrolled 80 women with conclusive diagnosis of tubal pregnancy and  $\beta$ -hCG level less than 1,500 IU/L; 42 received methotrexate and 38 women were assigned to placebo group. The success rates were 83% and 76% in methotrexate and placebo groups,

respectively. There was no statistically significant difference between the groups suggesting that in clinically stable women with confirmed ectopic pregnancy and with  $\beta$ -hCG levels less than 1,500 IU/mL expectant management is a safe and effective method.<sup>239</sup>

**Considering the potentially serious risks of tubal rupture and hemorrhage and the established safety and effectiveness of both medical and surgical treatments of ectopic pregnancy, it seems prudent that expectant management should be reserved only for asymptomatic patients with very low and falling  $\beta$ -hCG levels.** The acceptable upper limit of  $\beta$ -hCG has not been established, but a threshold value of 200 IU/L has been suggested.<sup>19</sup> It is important to remember that tubal rupture has been reported even in women with low and declining  $\beta$ -hCG concentrations.<sup>240</sup> If expectant management is elected, close follow-up is essential and  $\beta$ -hCG levels should be followed until undetectable. Any plateau or rise in the  $\beta$ -hCG concentration should prompt medical or surgical treatment.

Limited evidence indicates that long-term outcomes (subsequent intrauterine and ectopic pregnancies) after successful expectant management are comparable to those achieved with medical and surgical treatment.<sup>241</sup>

# MEDICAL TREATMENT OF ECTOPIC PREGNANCY

---

Methotrexate, potassium chloride, hyperosmolar glucose, actinomycin D, and prostaglandins all have been used successfully as medical treatments for ectopic pregnancy.<sup>242,243,244,245,246,247</sup> Direct local injections into the ectopic gestational sac under ultrasonographic or laparoscopic guidance have been described but generally are reserved for the treatment of ectopic pregnancies in unusual sites (abdominal, cervical, interstitial) or conditions (heterotopic pregnancy), as discussed below. Systemic methotrexate therapy is simpler and less invasive. **Methotrexate has been studied extensively and now is established as a safe and effective alternative to surgical treatment for ectopic pregnancy.**<sup>7,12,248</sup> Medical management avoids the inherent morbidity of anesthesia and surgery and reduces costs.<sup>249</sup> Success rates and future reproductive performance also are comparable to those observed with surgical management.<sup>9,249,250</sup>

**Methotrexate is a folic acid antagonist that inactivates the enzyme dihydrofolate reductase, thereby depleting available stores of tetrahydrofolate, an essential cofactor in DNA and RNA synthesis during cell multiplication. Rapidly proliferating tissues like trophoblasts are particularly vulnerable to its actions.** Considering that methotrexate has long been used successfully for the treatment of gestational trophoblastic disease, the drug was a logical choice for the treatment of ectopic pregnancy. Even in women with undesired viable early intrauterine pregnancies, methotrexate treatment decreases the rate of increase in serum  $\beta$ -hCG levels; as a direct result, progesterone and 17-hydroxyprogesterone concentrations also fall.<sup>251</sup> Methotrexate is cleared rapidly, via the kidneys; 90% of an intravenous bolus dose is excreted unchanged within 24 hours.<sup>252</sup>

# Prognostic Indicators

Numerous studies have sought to define ultrasonographic and biochemical characteristics that might reliably predict success or failure with medical treatment for ectopic pregnancy.<sup>253,254,255,256,257,258</sup> The size of any demonstrable extrauterine gestational mass, the presence or absence of embryonic heart activity or cul-de-sac fluid, and baseline serum  $\beta$ -hCG and progesterone concentrations all have been examined as potential prognostic indicators.

## Ultrasonographic Characteristics

**An ectopic gestational mass greater than 3–4 cm is widely considered as a relative contraindication to medical treatment with methotrexate, and surgical management is deemed as the preferred first-line approach in this setting.**<sup>19,259,260,261,262</sup> There are few data to justify the recommendation, primarily because virtually all studies have limited treatment to women with ectopic pregnancies measuring less than 3.5–4 cm. In one study of 44 women treated with intratubal injection of methotrexate, ectopic pregnancies measuring 2 cm or less regressed more often (76%) than larger masses (52%).<sup>263</sup> However, larger studies involving systemic methotrexate therapy have observed no correlation between size and treatment success,<sup>160,258,264</sup> possibly because the ectopic pregnancy cannot always be distinguished from surrounding blood clot or because size does not accurately predict viability. **In reality, the distinction has limited importance because relatively few ectopic pregnancies imaged with ultrasonography exceed 4 cm in size.**<sup>258,263,264,265</sup>

**Ultrasound evidence of embryonic heart activity and free peritoneal fluid are also considered relative contraindications to medical treatment.**<sup>19,254,260,261,262,263,265</sup> Medical treatment can succeed, but fails significantly more often when heart activity is present (odds ratio [OR] = 9.09; CI = 3.8–22).<sup>264,266</sup> Free peritoneal fluid, presumably blood, has been viewed as evidence suggesting tubal rupture and intra-abdominal hemorrhage. In older studies, 70–80% of ectopic pregnancies were associated with a positive culdocentesis (recovery of nonclotting blood), even though only 40–50% were ruptured.<sup>267,268</sup> Peritoneal blood also can result from tubal abortion. **More contemporary studies involving ultrasonography indicate that free peritoneal fluid may be observed in almost 40% of women with early unruptured ectopic pregnancies and that the presence or absence of cul-de-sac fluid does not accurately predict the success or failure of medical treatment.**<sup>258</sup> Thus, cul-de-sac fluid, by itself, in the absence of symptoms, has relatively little value in guiding choice of treatment or offering prognosis on likelihood of success of medical treatment.



## Serum $\beta$ -hCG Concentrations

Whereas ultrasonographic observations have limited prognostic value, serum  $\beta$ -hCG concentrations are quite useful. **The likelihood of failed medical treatment correlates directly with the initial serum  $\beta$ -hCG concentration; as the level rises, the probability of success decreases.**<sup>258,269</sup> A systematic review and analysis of data derived from five observational studies involving 503 women found a substantial and significant increase in failure rate for patients with initial  $\beta$ -hCG concentrations greater than 5,000 IU/L, compared with that for women with levels less than 5,000 IU/L (OR = 5.45; CI = 3.04–9.78)<sup>269</sup> (Table 33.2).

### TABLE 33.2

Serum $\beta$ -hCG (IU/L)	Women Treated Successfully (%) <sup>269</sup>
<1,000	98.5
1,000–1,999	94.4
2,000–4,999	96.2
5,000–9,999	85.7
10,000–150,000	81.2

The correlation between serum  $\beta$ -hCG concentrations and treatment success is understandable. High or normally increasing serum  $\beta$ -hCG levels suggest an advanced and progressing ectopic pregnancy.<sup>12</sup> Conversely, low serum  $\beta$ -hCG concentrations and absent embryonic heart activity are more likely to be associated with a very early or failing ectopic pregnancy having greater sensitivity to methotrexate therapy. Not surprisingly, the prevalence of embryonic heart activity increases with higher  $\beta$ -hCG concentrations. Heart activity is present in only 5% of ectopic pregnancies associated with a  $\beta$ -hCG level less than 5,000 IU/L, but observed in 27% with  $\beta$ -hCG levels between 5,000 and 10,000 IU/L, in 41% with levels between 10,000 and 15,000 IU/L, and in 50% of ectopic pregnancies associated with a serum  $\beta$ -hCG level over 15,000 IU/L.<sup>258</sup> **The correlation between  $\beta$ -hCG concentrations and embryonic heart activity explains why medical treatment fails more often when heart activity is observed.**

In general, as one might logically expect, serum progesterone concentrations correlate closely with the  $\beta$ -hCG level. The serum progesterone level, however, has no significant added predictive value to that offered by  $\beta$ -hCG alone.

# Indications and Contraindications to Medical Management of Ectopic Pregnancy

Logically, the best candidates for medical treatment of ectopic pregnancy are those in whom treatment is most likely to succeed, although there are other important practical considerations. The ideal candidate has the following characteristics.

## Absolute Requirements

- Hemodynamic stability
- No evidence of tubal rupture or acute intra-abdominal bleeding
- Reliable commitment to comply with required follow-up care
- No contraindications to methotrexate treatment (see below)

## Preferred Characteristics

- Absent or minimal symptoms (pain)
- Serum  $\beta$ -hCG concentration less than 5,000 IU/L
- Absent embryonic heart activity
- Ectopic mass measuring less than 4 cm in diameter
- Willing to accept blood products in case of emergency
- Easy access to health care system

The first four criteria are the most important, for obvious reasons. Among the second four criteria, the first is a practical consideration; it is difficult to justify medical treatment in women with severe or unrelenting pain, which can be signs of impending or ongoing rupture. The next two predict a high probability for success. **Medical treatment is not contraindicated for ectopic pregnancies associated with serum  $\beta$ -hCG concentrations greater than 5,000 IU/L or presence of embryonic heart activity, but the likelihood of treatment failure and the risk of tubal rupture are increased substantially.**<sup>248,253,258</sup> The second to last criterion conforms to convention in the absence of any data to indicate the safety of medical treatment in women with larger ectopic pregnancies.

Women who do not meet the absolute requirements listed above and those having a specific contraindication to methotrexate are not candidates for medical treatment.<sup>19,270</sup>

## Contraindications to Methotrexate Treatment

- Viable and desired intrauterine pregnancy
- Breastfeeding

- Immunodeficiency states
- Hematologic abnormalities (severe anemia, leukopenia, thrombocytopenia)
- Known sensitivity to methotrexate
- Active pulmonary disease
- Active peptic ulcer disease
- Alcoholism
- Clinically important hepatic or renal dysfunction

# Systemic Methotrexate Treatment

Early trials of methotrexate treatment for ectopic pregnancy were modeled after regimens already in wide use for the treatment of gestational trophoblastic disease. Consequently, the first suggested treatment regimen involved multiple alternating daily doses of methotrexate and folinic acid (also known as leucovorin or citrovorum).<sup>259,271</sup> As experience with medical treatment expanded, a single-dose regimen was introduced in efforts to simplify treatment, improve compliance, and reduce side effects and costs.<sup>248,254,261</sup> A two-dose treatment regimen also has been described, aimed at maximizing success rates while minimizing the number of injections and visits required (Table 33.3).<sup>272</sup>

## TABLE 33.3

Treatment Day	Single-Dose Regimen	Two-Dose Regimen	Multidose Regimen
1	$\beta$ -hCG MTX 50 mg/m <sup>2</sup> IM	$\beta$ -hCG MTX 50 mg/m <sup>2</sup> IM	$\beta$ -hCG MTX 1 mg/kg IM
2			LEU 0.1 mg/kg IM
3			$\beta$ -hCG If $\geq 15\%$ decrease (day 1–3), repeat $\beta$ -hCG weekly until undetectable If $< 15\%$ decrease, MTX 1 mg/kg IM
4	$\beta$ -hCG	$\beta$ -hCG MTX 50 mg/m <sup>2</sup> IM	LEU 0.1 mg/kg IM (if MTX on day 3)
5			$\beta$ -hCG If $\geq 15\%$ decrease (day 3–5), repeat $\beta$ -hCG weekly until undetectable If $< 15\%$ decrease, MTX 1 mg/kg IM
6			LEU 0.1 mg/kg IM (if MTX on day 5)
7	$\beta$ -hCG If $\geq 15\%$ decrease (day 4–7), repeat $\beta$ -hCG weekly until undetectable If $< 15\%$ decrease, MTX 50 mg/m <sup>2</sup> IM	$\beta$ -hCG If $\geq 15\%$ decrease (day 4–7), repeat $\beta$ -hCG weekly until undetectable If $< 15\%$ decrease, MTX 50 mg/m <sup>2</sup> IM	$\beta$ -hCG If $\geq 15\%$ decrease (day 5–7), repeat $\beta$ -hCG weekly until undetectable If $< 15\%$ decrease, MTX 1 mg/kg IM
8			LEU 0.1 mg/kg IM (if MTX on day 7)
11	$\beta$ -hCG If $\geq 15\%$ decrease, repeat $\beta$ -hCG weekly until undetectable If $< 15\%$ decrease, MTX 50 mg/m <sup>2</sup> IM	$\beta$ -hCG If $\geq 15\%$ decrease, repeat $\beta$ -hCG weekly until undetectable If $< 15\%$ decrease, MTX 50 mg/m <sup>2</sup> IM	$\beta$ -hCG If $\geq 15\%$ decrease, repeat $\beta$ -hCG weekly until undetectable If $< 15\%$ decrease, surgical treatment
14	$\beta$ -hCG If $\geq 15\%$ decrease, repeat $\beta$ -hCG weekly until undetectable If $< 15\%$ decrease, surgical treatment	$\beta$ -hCG If $\geq 15\%$ decrease, repeat $\beta$ -hCG weekly until undetectable If $< 15\%$ decrease, surgical treatment	

Regardless which treatment regimen is selected, pretreatment evaluation should include the following:

- **Complete blood count**
- **Blood type and Rh(D)**
- **Serum creatinine**
- **Liver function tests**
- **Transvaginal ultrasonography**

In addition, patients should be advised to discontinue any folic acid supplements, including prenatal vitamins, that they may be taking, as well as avoid direct sun exposure (to decrease risk of methotrexate dermatitis), use of nonsteroidal anti-inflammatory drugs (interaction with methotrexate may cause bone marrow suppression or gastrointestinal toxicity), and intercourse or strenuous physical activity (to decrease the risk of tubal rupture).

Although Rh(D) immunoglobulin treatment is recommended commonly for all women with Rh-negative blood type who have an ectopic pregnancy or early spontaneous abortion,<sup>273,274</sup> evidence to support the recommendation is weak. Overall, the likelihood of Rh sensitization after ectopic pregnancy is extremely small because ectopic pregnancies are rarely sufficiently advanced to have a fetal blood volume that is large enough to pose a significant risk of maternal sensitization. It is entirely possible that treatment may be necessary only for ectopic pregnancies that reach at least 8 weeks of gestation.<sup>275</sup> Nevertheless, current recommendations are to administer at least 50  $\mu\text{g}$  of Rh immunoglobulin to all nonsensitized Rh-negative women diagnosed with an ectopic pregnancy or experiencing early spontaneous abortion (protection against a fetomaternal hemorrhage of up to 2.5 mL).<sup>273</sup> Because side effects and complications of treatment are rare, the overall balance of risks and benefits favors treatment.

It is important to note that the single-dose, two-dose, and multidose methotrexate treatment regimens are named for the number of doses **intended**, rather than the number actually administered. Moreover, the first day of treatment has not been consistently defined, designated in some studies as day 0, and in others as day 1. In the absence of evidence that it matters, and for clarity, the different treatment regimens are described here as beginning on day 1.

In the “single-dose” treatment regimen, methotrexate is administered in a single dose (intramuscular 50 mg/m<sup>2</sup>, day 1), and serum  $\beta$ -hCG is measured on days 4 and 7; a decline in serum  $\beta$ -hCG by 15% or more between days 4 and 7 is taken to reflect treatment success, and  $\beta$ -hCG concentrations are monitored weekly thereafter until undetectable. In the majority of women (85%), serum  $\beta$ -hCG concentrations rise somewhat between days 1 and 4.<sup>248,276</sup> This observation is deemed as predictable and does not necessarily indicate failed treatment. However, any subsequent further increase in  $\beta$ -hCG levels, or a decrease in  $\beta$ -hCG of less than 15% between days 4 and 7, is indication for a second dose of methotrexate (to be administered on day 7); thenceforth, the same criteria are followed and adequacy of treatment response is assessed on day 11. If required, a third dose of methotrexate can be administered on day 11 and response evaluated by measuring  $\beta$ -hCG again on day 14. Although a fourth dose of methotrexate can be administered on day 14 if decline in  $\beta$ -hCG is suboptimal, surgical treatment should be given serious consideration after 2 weeks of failed medical treatment.

In the two-dose treatment regimen, methotrexate is administered on days 1 and 4 (intramuscular 50 mg/m<sup>2</sup>). Similar to the single-dose regimen, if the serum  $\beta$ -hCG declines 15% or more between days 4 and 7,  $\beta$ -hCG is monitored weekly until levels become undetectable. If the  $\beta$ -hCG concentrations decrease by less than 15% between days 4 and 7, a third dose of methotrexate is administered (on day 7), and the same criterion is applied in judging the response to treatment on day 11.<sup>272</sup> If necessary, a fourth dose is administered (on day 11) and the serum  $\beta$ -hCG concentration is assessed again on day 14. Similar to the single-dose regimen, surgical treatment should be given serious consideration after 2 weeks of failed medical treatment.

In the multidose treatment regimen, methotrexate (intramuscular 1 mg/kg) and leucovorin (intramuscular 0.1 mg/kg) are administered on alternate days, up to a maximum of four doses, until the serum  $\beta$ -hCG level declines by 15% from the previous value. Thereafter,  $\beta$ -hCG concentrations are monitored on a weekly basis until levels become undetectable.

Routine serial sonography during medical treatment is not useful. After methotrexate treatment, half or more of ectopic masses actually enlarge, probably due to formation of hematomas, but such observations do not predict treatment failure and most patients remain asymptomatic.<sup>160,277</sup> **In women with complaints of increasingly severe abdominal pain, repeat ultrasonography should be performed to detect an obvious increase in peritoneal fluid, suggesting rupture of a tubal pregnancy.** Moderate to severe pain, fluid level extending above the uterine fundus or surrounding the ovary, and a hemoglobin concentration less than 10 g/dL suggest a significant hemoperitoneum; one study found that the probability of a hemoperitoneum amounting to 300 mL or more was 93% when two or more of the criteria were met.<sup>278</sup>

It is important to note that symptoms of pain commonly emerge or increase over the days following methotrexate treatment.<sup>248</sup> The cause is uncertain but most likely reflects tubal abortion (expulsion via the fimbria) or peritoneal tension resulting from a hematoma.<sup>216,279</sup> **A complaint of increasingly severe pain should prompt a thorough reevaluation to determine whether observation and medical treatment can be continued safely, but is not, by itself, an indication for immediate surgery.** Although “separation pain” may be the most likely cause, tubal rupture also is a possibility. Most patients can be reassured and outpatient management can be continued. Some may require hospitalization for more careful observation. Even those with severe or unrelenting pain after methotrexate treatment often can be managed with analgesics and serial hematocrit assessments as long as they remain hemodynamically stable.<sup>279</sup> In a review of 56 women with abdominal pain severe enough to require reevaluation or hospitalization, only 8 ultimately required surgical treatment.<sup>279</sup> However, stubborn adherence to medical management can be difficult to justify in those with severe pain.



**Surgical treatment is indicated when a ruptured ectopic pregnancy is suspected or diagnosed or when the patient elects not to continue medical treatment.**

## **Outcomes of Medical Treatment**

In numerous independent case series, both the single-dose and multidose methotrexate treatment regimens have achieved excellent success rates (75–95%).<sup>216,266</sup> A meta-analysis including 26 nonrandomized studies involving 1,327 cases of ectopic pregnancy treated with systemic methotrexate found that both single-dose treatment (1,067 women; 88% successful) and multidose therapy (260 women; 93% successful) were highly effective.<sup>266</sup> **However, when viewed from the opposite perspective, the failure rate of single-dose treatment (127/1,067; 12%) was significantly higher (OR = 1.7; CI = 1.04–2.82) than for multidose therapy (19/260; 7%). After adjustment for other known prognostic indicators ( $\beta$ -hCG concentration, embryonic heart activity), the higher risk of failure with single-dose treatment was even more striking (OR = 4.8; CI = 1.8–12.6).**<sup>266</sup> The gross difference in success rates between the two treatment regimens (approximately 5%) is comparable to that observed by other investigators<sup>264,280,281</sup> and suggests that for every 20 women treated with multidose rather than single-dose therapy, at least one surgical procedure can be avoided. The results of a small randomized trial are consistent with those of the meta-analysis; treatment was successful in 48/54 women (89%) receiving single-dose therapy and in 50/54 (93%) in those who received multidose therapy.<sup>282</sup>

The meta-analysis observed that single-dose treatment often involves more than one dose of methotrexate (15%) and multidose therapy frequently requires less than four doses (50%).<sup>266</sup> Success rates also were higher in women who received a second “single-dose” (50 mg/m<sup>2</sup>) treatment and lower in those who required more than four doses during multidose (1 mg/kg) therapy. These observations suggested the optimal treatment regimen likely would involve at least two doses of methotrexate.

The efficacy of a planned two-dose regimen was evaluated in a study involving 104 women with a diagnosis of ectopic pregnancy (ultrasonographic imaging of an extrauterine gestational sac containing a yolk sac and/or fetal pole, no products of conception observed in frozen section performed on uterine curettings, or an increase in  $\beta$ -hCG 12–24 hours after curettage).<sup>272</sup> Ultimately, three patients were diagnosed with a failed intrauterine pregnancy after products of conception were identified on final pathologic examination of uterine curettings. Among the remaining 101 women, 88 were treated successfully (87%); 3 required only a single dose of methotrexate, 73 received the planned two doses of treatment, 7 required a third dose, and 5 required four doses. Medical treatment failed in 13/101 patients (13%) and all received surgical treatment;

three were diagnosed with a ruptured ectopic pregnancy, four elected surgical treatment after medical therapy began, four had a plateau in  $\beta$ -hCG levels after an initial decline and chose surgery over additional medical treatment, and two received surgical treatment because of increasing  $\beta$ -hCG or liver transaminase levels.<sup>272</sup> Whereas the results achieved with the two-dose treatment regimen are comparable to those reported for single-dose and multidose treatment regimens, the success rate may be a conservative estimate, primarily because all patients met fairly strict criteria for diagnosis of ectopic pregnancy. **Patients included in previous series and trials often did not receive uterine curettage, making it likely that many did not, in fact, have an ectopic pregnancy, resulting in falsely inflated estimates of the success of medical treatment.**

A recent systematic review and meta-analysis examined six clinical trials comparing single to multidose regimens of methotrexate.<sup>283</sup> Three randomized controlled trials involving a total of 325 clinically stable patients demonstrated similar rates of successful resolution for the two-dose and single-dose protocols (RR = 1.09; 95% CI = 0.98–1.20) and comparable risk of adverse effects (RR = 1.33; 95% CI = 0.92–1.94).<sup>283</sup> However, in two of the three trials included in the review, the two-dose regimen was associated with greater success among women with high initial  $\beta$ -hCG levels. In the first trial, there was a nonstatistically significant trend toward greater success for the two-dose regimen in the subgroup with an initial  $\beta$ -hCG level greater than 5,000 mIU/mL (80.0% vs. 58.8%; P = 0.279; RR = 0.74; 95% CI = 0.47–1.16).<sup>284</sup> The second trial reported a statistically significant higher success rate for the two-dose regimen versus the single-dose regimen in patients with initial serum hCG levels between 3,600 and 5,500 mIU/mL (88.9% vs. 57.9%; P = 0.03; OR = 5.80; 95% CI = 1.29–26.2).<sup>285</sup>

A more recent systematic review and meta-analysis, which included 11 trials and 1,121 patients treated with single-dose and non-single-dose protocols, demonstrated similar success rates (RR = 1.00; 95% CI = 0.96–1.04) with non-single-dose regimens associated with higher adverse effect rates.<sup>286</sup>

**Ipsilateral tubal patency rates after successful medical treatment of ectopic pregnancy are generally comparable to those observed after conservative laparoscopic surgical treatment (linear salpingostomy) and range between 60% and 85%.<sup>30,248,280,287,288,289</sup> Among those who seek another pregnancy, subsequent reproductive performance and pregnancy outcomes also are similar. In general, 50–80% of women treated with methotrexate later achieve an intrauterine pregnancy, whereas 10–20% experience a recurrent ectopic pregnancy.<sup>29,30,290</sup> Women with ectopic pregnancies associated with an IUD typically have a better prognosis, probably**

because their ectopic pregnancy was less likely related to tubal pathology.<sup>290</sup> As might be expected, older women,<sup>22,291,292,293</sup> previously infertile women,<sup>294,295,296</sup> and those with past history of ectopic pregnancy or tubal damage<sup>22,291,294</sup> have a poorer prognosis. **In essence, fertility after ectopic pregnancy depends more on already established patient characteristics than on the method of treatment.**<sup>297,298</sup>

Occasionally, the ectopic gestational mass may persist for weeks after successful medical treatment. Whereas it seems prudent to postpone new attempts to conceive again until the mass resolves completely, whether the delay is necessary or may reduce risk for another ectopic pregnancy is unknown.

Evidence from studies of pregnancy outcomes in women treated with methotrexate for ovarian germ cell tumors,<sup>299</sup> gestational trophoblastic disease,<sup>300</sup> or ectopic pregnancy<sup>301,302</sup> do not suggest that treatment has any adverse effect on the outcomes of future pregnancies or on ovarian reserve.<sup>303</sup>

## Side Effects and Complications

Although medical treatment is a viable option for many women with unruptured ectopic pregnancies and, on average, costs significantly less than surgical treatment,<sup>304</sup> it is not necessarily the best option for all women. Medical treatment avoids anesthesia and invasive surgery, but also has its drawbacks. If thoroughly counseled and given the choice, some women prefer surgical to medical treatment.<sup>305</sup>

Whereas surgery usually is definitive and followed by a prompt return to normal function, medical treatment can become tedious and inconvenient. The results of both medical and conservative surgical treatments must be monitored with serial serum  $\beta$ -hCG determinations to ensure that treatment has been successful, but levels typically fall about twice as fast after surgery.<sup>306</sup> **When medical treatment is successful, the time to resolution (undetectable serum  $\beta$ -hCG) generally correlates with the initial serum  $\beta$ -hCG concentration; the average time to resolution is approximately 5 weeks.**<sup>248,306</sup> Unfortunately, some women may require weekly monitoring for up to 3 months or more before  $\beta$ -hCG is no longer detectable.<sup>248,264</sup>

**Side effects of methotrexate are relatively common, but also usually minor and transient; their prevalence is somewhat higher with multidose therapy than with single-dose treatment.**<sup>266</sup> Elevated hepatic transaminases are the most common. Nausea, vomiting, and diarrhea may result from a drug-induced gastritis or enteritis. Methotrexate-induced stomatitis, reversible alopecia, and pneumonitis are uncommon. Serious side effects are rare and include severe bone marrow suppression and hepatotoxicity. When necessary, treatment with leucovorin can help to reduce their

severity and speed resolution.

Compared to women who receive surgical treatment, medically treated women more often experience prolonged vaginal bleeding and perceive more depression and limitations in physical and social function.<sup>288,307</sup> **Tubal rupture requiring emergent surgery during medical treatment can and does occur, even when serum  $\beta$ -hCG levels are falling; tubal rupture has been observed as long as 6 weeks after initiation of medical treatment.**<sup>216</sup> Evidence from randomized trials comparing systemic methotrexate and conservative surgical treatment indicates that approximately 15% of women first treated medically ultimately require surgery, about half because of tubal rupture.<sup>287,288</sup> Isthmic tubal ectopic pregnancies are at higher risk for rupture, but cannot be accurately differentiated from more common ampullary implantations without laparoscopy. **Fortunately, tubal rupture does not appear to have any independent adverse effect on subsequent fertility or pregnancy outcomes.**<sup>32</sup>

# Local Medical Treatment by Direct Injection

Methotrexate also can be administered by direct local injection (1 mg/kg) into an ectopic gestational sac under laparoscopic or ultrasonographic guidance.<sup>265,306,308</sup> The method delivers a high concentration of the drug to the site of implantation and achieves circulating concentrations comparable to those seen with systemic therapy.<sup>309</sup> A large experience with direct local injection of methotrexate has accumulated, mostly in Europe. Overall, results have been somewhat inconsistent but generally comparable to those achieved with systemic therapy.<sup>30</sup> This approach of medical intervention is more invasive, is more costly, and requires greater technical skill. With those disadvantages, and no clear advantages, systemic methotrexate treatment is the more logical choice.

The efficacy and safety of direct local injection of other medications (potassium chloride, hyperosmolar glucose) and their long-term impact on fertility are not well established because experience is limited.<sup>30</sup> However, intratubal injection of potassium chloride or hyperosmolar glucose does have one important and specific niche application. In heterotopic pregnancies, the method can ablate the ectopic implantation without compromising a coexisting viable intrauterine pregnancy while also avoiding surgery and its attendant potential complications.<sup>310</sup>

# **SURGICAL TREATMENT FOR ECTOPIC PREGNANCY**

---

Traditionally, ectopic pregnancies were treated surgically and salpingectomy was the most common operation performed. However, the contemporary management of ectopic pregnancy in asymptomatic patients has moved away from surgical treatment. Nonetheless, many women still receive surgical treatment, by choice, or because they are poor candidates for medical treatment. As modern methods for early diagnosis of unruptured ectopic pregnancies emerged, conservative procedures like linear salpingostomy and segmental resection are preferred approaches for those electing surgical treatment, as well as needing emergent surgery. At first, most operations still were performed via laparotomy, but soon thereafter, laparoscopic surgery became standard treatment for unruptured ectopic pregnancies. With the instrumentation available today, even most ruptured ectopic pregnancies can be successfully managed laparoscopically.

# Indications for Surgical Management

The following generally are accepted as indications for choosing surgical treatment over medical therapy:

- Hemodynamic instability
- Rupture of an ectopic mass
- Coexisting viable intrauterine pregnancy
- Unwillingness or inability to comply with required follow-up after medical treatment
- Lack of ready access to a hospital for management of tubal rupture
- Desire for permanent sterilization
- Contraindications to medical treatment
- Failed medical treatment

Surgical treatment also merits serious consideration for women having clinical characteristics known to be associated with an increased risk for failed medical therapy, such as a serum  $\beta$ -hCG concentration over 5,000 IU/L or demonstrable embryonic heart activity. In women who are stable hemodynamically, surgical treatment should be reserved for those having a demonstrable extrauterine gestational sac or an adnexal mass consistent with the diagnosis of ectopic pregnancy. Otherwise, there is a high probability that no ectopic pregnancy will be identified at surgery. Such women are best managed expectantly until the diagnosis is more firmly established, by serial  $\beta$ -hCG measurements and timely ultrasonography or by performing curettage (provided a viable intrauterine pregnancy can be confidently excluded). Alternatively, they can be treated empirically with medical therapy, realizing that many will receive unnecessary methotrexate treatment and thereafter carry a presumptive diagnosis that clouds their prognosis and decisions regarding future treatment.

Surgery does have some distinct advantages over medical therapy, primarily including a shorter time to resolution of the ectopic pregnancy, with no need for prolonged monitoring. Surgery also allows for an accurate assessment of the pelvic anatomy, which helps in subsequent counseling and treatment planning.

# Surgical Techniques

For the treatment of ectopic pregnancy, laparoscopy has several advantages over laparotomy—less blood loss, fewer adhesions, less operating time, a shorter hospital stay (usually <24 hours), reduced postoperative analgesic requirements, and a more rapid convalescence—all of which also help to reduce costs.<sup>30,311,312,313,314,315,316,317,318</sup>

There are two operative techniques used for surgical management of tubal pregnancy: salpingectomy and salpingostomy. Salpingostomy technique involved is straightforward. A longitudinal incision is made on the antimesenteric surface of the fallopian tube directly over the bulging mass using an electrosurgical needle or scissors, or a laser, and the products of conception are gently removed with forceps or irrigation. Preliminary injection of a dilute solution of aqueous vasopressin (1 unit/mL)<sup>319</sup> or oxytocin (20 units)<sup>320</sup> into the subjacent mesosalpinx can help to minimize the amount of electrocautery needed to achieve hemostasis. The incision may be sutured closed, but usually is left open to heal by itself; long-term reproductive outcomes are the same with either technique.<sup>321</sup> Because the bulk of the ectopic mass usually resides just beneath the serosa, the endosalpingeal mucosa most often can be left relatively undisturbed. Attempts at linear salpingostomy are successful in approximately 80% of women; in the remainder, persistent bleeding may require salpingectomy. Unsuccessful salpingostomy procedures are associated with higher serum  $\beta$ -hCG concentrations,<sup>322</sup> possibly because the ectopic gestation in these situations is more advanced and possesses a more highly developed neovasculature.

The decision to perform salpingostomy or salpingectomy should be based on the patient's clinical status, on the desire for future fertility, and on the observed extent of damage and potential for salvage of the affected fallopian tube. Two randomized controlled trials did not reveal any statistical difference in the subsequent intrauterine pregnancy rate (RR = 1.04; 95% CI = 0.89–1.21; P = 0.61) or the repeat ectopic pregnancy rate (RR = 1.30; 95% CI = 0.72–2.38; P = 0.39) between salpingostomy and salpingectomy groups. Meta-analysis of cohort studies, however, showed that salpingostomy was associated with both higher intrauterine pregnancy rate compared with salpingectomy rate (RR = 1.24; 95% CI = 1.08–1.42; P = 0.002) and higher tubal ectopic pregnancy recurrence rate (RR = 2.27; 95% CI = 1.12–4.58; P = 0.02).<sup>323</sup>

In general, salpingectomy is preferred when the affected fallopian tube is severely damaged or when significant bleeding is encountered despite attempts at achieving hemostasis. Unilateral salpingectomy may be a method of choice in patients desiring future fertility with a distorted affected tube when the contralateral tube appears normal or when the patient desires permanent sterilization. In the latter case, bilateral salpingectomy is performed. Salpingostomy is preferred when the remainder of the tube



appears normal and particularly so when fertility is desired but contralateral tube is damaged. If salpingostomy is performed, serial  $\beta$ -hCG monitoring is required to confirm resolution of ectopic trophoblastic tissue.

**Attempts at fimbrial evacuation of the ectopic pregnancy, such as by “milking the affected segment,” are likely to cause greater damage to the tube than linear salpingostomy and are best reserved for those where the ectopic products of conception are already protruding through the fimbria.**<sup>324</sup> The typical subserosal propagation of ampullary ectopic pregnancies explains why “milking” a more proximal ectopic is not recommended. **Isthmic ectopic pregnancies probably are best managed by segmental excision, with the option of later microsurgical tubotubal anastomosis.** The lumen of the isthmic segment of the fallopian tube is much narrower than that of the ampulla and is more likely to be damaged by salpingostomy and more prone to postoperative obstruction. The involved segment is simply excised, taking care to ensure that hemostasis is achieved.

In all cases, every effort should be made to preserve the adjacent ovary. The only indication for salpingo-oophorectomy (which rarely arises) is bleeding that cannot be controlled by more conservative measures.

# Outcomes of Surgical Treatment

Observational studies indicate that cumulative intrauterine pregnancy rates are significantly higher after salpingostomy than after salpingectomy (73% vs. 57%), but the incidence of recurrent ectopic pregnancy also is higher (15% vs. 10%).<sup>28,30,31</sup> Parous women are more likely to conceive again than nulliparous women.<sup>296,325</sup> Women with a normal contralateral tube have a higher probability of achieving an intrauterine pregnancy and a lower risk for recurrent ectopic pregnancy than those with contralateral tubal pathology.<sup>318,325,326</sup>

**Conservative surgical treatment is successful (requires no additional treatment) in approximately 90% of women with unruptured ectopic pregnancies.** The combined results of two randomized trials<sup>313,314,316</sup> indicate that salpingostomy is less often successful when performed laparoscopically than via the open surgical approach (OR = 0.28; CI = 0.09–0.86), because the incidence of persistent trophoblast is higher following conservative management (OR = 3.5; CI = 1.1–11).<sup>30</sup> **Among women who desire future fertility, tubal patency rates (80–90%) and intrauterine (55–75%) and recurrent ectopic pregnancy rates (10–15%) after laparoscopy or laparotomy are similar.**<sup>30</sup>

## Persistent Ectopic Pregnancy

**Persistent ectopic pregnancy is the most common and potentially serious complication of conservative surgical treatment for ectopic pregnancy.**<sup>327</sup> The phenomenon was first described in 1979.<sup>328</sup> The reported incidence of persistent ectopic pregnancy has ranged widely from 3% to almost 30%,<sup>329,330,331,332</sup> in part because of differences in definition (postoperative increase in serum  $\beta$ -hCG vs. continued growth requiring additional treatment).<sup>331,333</sup> The risk for persistent ectopic pregnancy may be increased when surgery is performed early (before 6 weeks of gestation) and for small ectopic pregnancies (<2 cm in diameter), which may be more difficult to identify and excise completely,<sup>329,330,334</sup> is more common following laparoscopic procedures compared to when ectopic pregnancy is managed via laparotomy.<sup>335</sup> **Clinicians must remain alert to the possibility because unrecognized persistent ectopic pregnancies frequently rupture during the postoperative period.**<sup>336</sup>

**The most effective way to identify persistent ectopic pregnancies is to monitor serum  $\beta$ -hCG levels during the postoperative period, until resolution.** Recommendations have varied from every 3 days to 2 weeks. The postoperative day 1

serum  $\beta$ -hCG concentration has significant predictive value; the greater the fall from preoperative levels, the lower the incidence of persistent ectopic pregnancy.<sup>337</sup> A 50% decline is the threshold value offering the best blend of sensitivity (42%) and specificity (88%). Women in whom the serum  $\beta$ -hCG concentration falls less than 50% are more than three times as likely to have a persistent ectopic pregnancy (RR = 3.51; CI = 1.25–6.68), but the risk is quite low when levels fall by 80% or more.<sup>337</sup> **In light of these observations, it seems logical to recommend measuring serum  $\beta$ -hCG on postoperative day 1 and every 3–7 days thereafter, depending on the rate of decline, until levels are undetectable.** For those who exhibit evidence of persistent ectopic pregnancy (rising or slowly falling postoperative  $\beta$ -hCG concentrations), the single-dose methotrexate treatment regimen (intramuscular 50 mg/m<sup>2</sup>) is highly effective.<sup>338</sup>

A decision analysis comparing observation and prophylactic postoperative methotrexate, involving 1,000 hypothetical women treated with linear salpingostomy, concluded that prophylactic treatment results in fewer cases of tubal rupture, fewer procedures, and lower costs, but also invites complications relating to medical treatment.<sup>339</sup> Treatment can be offered routinely or reserved for those in whom the postoperative day 1 serum  $\beta$ -hCG does not fall by more than 50%. Regardless whether prophylactic treatment is or is not used, serum  $\beta$ -hCG levels should be monitored until no longer detectable. Intrauterine pregnancy rates after treatment of persistent ectopic pregnancy are similar to those after primary treatment.<sup>340</sup>

## **Recurrence Risk of Ectopic Pregnancy**

The chance of a repeat ectopic pregnancy in a woman with a history of one ectopic pregnancy is approximately 10% (OR = 3.0; 95% CI = 2.1–4.4). In a woman with two or more prior ectopic pregnancies, the risk of recurrence increases to more than 25% (OR = 11.17; 95% CI = 4.0–29.5).<sup>18</sup>

# UNUSUAL TYPES OF ECTOPIC PREGNANCY

---

Heterotopic pregnancies and abdominal, ovarian, interstitial, cervical, and cesarean scar ectopic pregnancies are rare and unusual variants that present unique challenges; management strategies must be individualized, prioritizing patient safety while keeping in perspective each woman's reproductive plans and wishes.

# Heterotopic Pregnancy

A heterotopic pregnancy involves coexisting pregnancies at distinctly different implantation sites. The most common combination is an intrauterine and an extrauterine gestation, most of the latter being in the tube (90%), although implantations in the cervix, ovary, interstitial segment, abdomen, and previous cesarean scar have all been reported.<sup>335,341,342,343,344,345,346</sup> The often quoted approximate incidence of 1/30,000 spontaneously conceived pregnancies was derived from calculations over 50 years ago, based on the observed incidence of ectopic pregnancy (0.37%) and dizygotic twinning (0.8%) at the time.<sup>81</sup> The incidence of heterotopic pregnancy has risen substantially due to increasing use of exogenous gonadotropins and ART. Today, the best overall current estimate is approximately 1/3,900 pregnancies,<sup>28,347,348</sup> but the incidence is about 1.5/1,000 pregnancies resulting from ART.<sup>349</sup>

**Heterotopic pregnancies often escape early recognition because both serum  $\beta$ -hCG concentrations and ultrasonography can be misleading.** Normally rising levels of  $\beta$ -hCG derived from a normally developing intrauterine pregnancy usually obscure the abnormal pattern typically observed in ectopic pregnancies, and when ultrasonography reveals an intrauterine pregnancy, the possibility of a coexisting ectopic pregnancy in an asymptomatic patient is seldom considered. Consequently, diagnosis is delayed and over half of all heterotopic pregnancies are recognized only after tubal rupture occurs.<sup>342</sup> The signs and symptoms of heterotopic pregnancy are similar to those of ectopic pregnancy but, unfortunately, are often dismissed due to the false reassurance offered by the coexisting intrauterine gestation.

**Treatment of a heterotopic pregnancy in the setting of a viable concomitant intrauterine pregnancy gets complicated.** Expectant management is inappropriate because neither serum  $\beta$ -hCG levels nor ultrasonography can accurately determine the fate of the ectopic pregnancy nor quantify the risk of rupture. Systemic methotrexate treatment is contraindicated when the intrauterine pregnancy is viable and desired. Even direct local injection of methotrexate<sup>350</sup> may be unwise because of the potential for systemic absorption and thereby exposure of the intrauterine gestation to a documented teratogen.<sup>309</sup> Surgical treatment by salpingostomy or salpingectomy while leaving the intrauterine gestation undisturbed is effective and generally is considered the treatment of choice.<sup>335,342</sup> Selective embryo reduction by direct local injection of potassium chloride<sup>310,351</sup> or hyperosmolar glucose<sup>352,353</sup> into the ectopic gestational sac is another viable treatment option. However, in a review of 11 cases of heterotopic pregnancy treated with potassium chloride injection, 6 patients failed medical therapy and required surgical treatment.<sup>335</sup>

Bilateral ectopic pregnancies as a form of heterotopic pregnancy have been described.<sup>354,355,356</sup>

# Abdominal Pregnancy

Abdominal ectopic pregnancies, involving implantation in the peritoneal cavity, are rare, with an estimated incidence of approximately 1/10,000 pregnancies and 1/100 ectopic pregnancies.<sup>357,358</sup> Implantation sites include the omentum, pelvic sidewall, broad ligament, cul-de-sac, spleen, bowel, liver, diaphragm, and serosa of the uterus. Whether abdominal pregnancies result from primary peritoneal implantation or secondary implantation following a tubal abortion is unknown. One reported case after IVF in a patient without tubes may have resulted from uterine perforation at the time of embryo transfer.<sup>358</sup>

The symptoms most frequently encountered are abdominal pain, nausea and vomiting, general malaise, and painful fetal movements, and the most frequent physical findings are abdominal tenderness, abnormal fetal lie, and a displaced uterine cervix.<sup>359</sup> In rare cases, diagnosis may follow a failed induction of labor.<sup>360</sup> Ultrasonography is the most accurate method for diagnosis, but fewer than half of all abdominal pregnancies are recognized before intra-abdominal hemorrhage occurs. The classic ultrasonographic sign is the absence of any myometrium between the maternal bladder and the pregnancy.<sup>361</sup>

Immediate surgery is the treatment of choice, except perhaps in rare cases of advanced abdominal pregnancy involving a fetus nearing viability when judicious delay to allow fetal lung maturation may be considered under stringent surveillance. If recognized early, an abdominal pregnancy may be amenable to laparoscopic surgery<sup>341,362,363</sup>; in one reported attempt, medical treatment with methotrexate was unsuccessful.<sup>364</sup> Although delivery of viable infants has been reported,<sup>361,365</sup> the likelihood is very low and the risk of maternal complications is very high. **The maternal mortality associated with abdominal pregnancy (at least 5/1,000 cases) is the highest of all types of ectopic pregnancy.**

Whereas delivery of the fetus is accomplished easily, management of the placenta is complicated. When technically feasible, the placenta should be removed because complications (hemorrhage, abscess, sepsis, intestinal obstruction, amniotic fluid cysts, hypofibrinogenemia) are otherwise common.<sup>366</sup> However, given the absence of cleavage planes, removal of the placenta can be challenging and hemorrhage is common and can be difficult to control.<sup>367</sup> When the placenta is left in situ, arterial embolization and systemic methotrexate treatment may help to speed its involution.<sup>361,368,369</sup>

# Ovarian Pregnancy

Ovarian pregnancy accounts for less than 3% of all ectopic pregnancies. The clinical signs and symptoms are the same as for more common tubal ectopic pregnancies.<sup>370,371</sup> Although ultrasonography may suggest the possibility, diagnosis usually is made only at surgery, or by the pathologist, because an ovarian ectopic pregnancy frequently is confused with a hemorrhagic corpus luteum at the time of surgery.<sup>370,372</sup> Diagnosis of ovarian pregnancy has specific criteria, but they are largely of academic relevance: (1) an intact ipsilateral tube, separate from the ovary, (2) a gestational sac occupying the position of the ovary, (3) a gestational sac connected to the uterus by the ovarian ligament, and (4) ovarian tissue in the wall of the gestational sac.<sup>373</sup> Treatment of almost all known ovarian ectopic pregnancies has been surgical. Case reports have described successful methotrexate therapy,<sup>374,375,376</sup> and it seems likely that many of the innumerable ectopic pregnancies that are treated medically may actually be ovarian implantations.



# Interstitial Pregnancy

No more than approximately 2% of tubal ectopic pregnancies implant in the interstitial tubal segment, which lies within the uterine wall and measures 1–2 cm in length. In the largest single series of 32 interstitial pregnancies collected by the Society for Reproductive Surgeons, 13 were recurrent ectopic pregnancies, 12 were in women with a previous ipsilateral salpingectomy, and 11 were in women who conceived after IVF.<sup>377</sup>

Conventional gynecologic wisdom has held that interstitial pregnancies rarely rupture before approximately 12 weeks of gestation because the myometrium surrounding the interstitial tubal segment is more distensible than the muscularis of the more distal portions of the fallopian tube. However, in the case series alluded to above, 14/32 (44%) interstitial pregnancies ruptured before diagnosis and all before 12 weeks (mean 6.9 weeks; range 5–12 weeks) of gestation.<sup>377</sup>

Most cases of interstitial pregnancy are diagnosed after the typical symptoms of ectopic pregnancies appear. The unusual location of interstitial pregnancies makes diagnosis difficult, but their ultrasonographic characteristics also are somewhat unique. A careful and experienced examiner may observe an eccentric gestational sac or heterogeneous mass, abnormal thinning of the myometrial mantle, or an abnormally prominent interstitial tubal segment (“the interstitial line”), the last criteria having the greatest diagnostic sensitivity (80%) and specificity (98%).<sup>378</sup> Other proposed criteria include the combination of an empty uterine cavity, a gestational sac separate and at least 1 cm from the lateral edge of the cavity, and a thin (<5 mm) myometrial layer surrounding the sac.<sup>379</sup> When doubt persists, laparoscopy can help to accurately differentiate true interstitial pregnancies from normal but eccentric or “angular” intrauterine pregnancies.<sup>380</sup>

Historically, the traditional treatment for interstitial pregnancy has been hysterectomy or cornual resection by laparotomy, primarily because most interstitial pregnancies were not recognized before rupture and often were associated with massive hemorrhage.<sup>343,381,382,383</sup> Now, earlier diagnosis of interstitial pregnancy offers the opportunity for more conservative surgical or medical treatment. Some advocate laparoscopic “cornuostomy” with excision of the interstitial portion of the tube, if necessary.<sup>377,381</sup> Others prefer primary medical therapy, typically using a multidose methotrexate treatment regimen, reserving surgery for those who fail medical management; in one series, 16/17 (94%) were treated successfully, including four cases in which embryonic heart activity was present.<sup>384</sup> Successful hysteroscopic resection of interstitial pregnancies and selective arterial embolization (alone or in combination with medical treatment) have also been described.<sup>385,386,387,388</sup> Direct local injection of

potassium chloride is another option that may have particular value for the treatment of heterotopic interstitial pregnancies.<sup>381,389</sup> A recently proposed “best practice” recommends systemic methotrexate therapy for hemodynamically stable women with interstitial ectopic pregnancies and laparoscopic surgical resection for those who are hemodynamically unstable or prefer surgery over medical treatment.<sup>383</sup>

The risk of uterine rupture in a subsequent pregnancy after successful treatment for an interstitial pregnancy is uncertain, but cases of uterine rupture have been reported.<sup>390,391</sup> Consequently, careful monitoring of any later pregnancy is essential, and cesarean delivery is recommended.

# Cervical Pregnancy

Cervical pregnancy is a rare type of ectopic pregnancy in which implantation occurs in the endocervical canal. The reported incidence ranges between 1/2,500 and 1/10,000 pregnancies.<sup>392,393</sup> Cervical pregnancy is somewhat more common among pregnancies conceived through ART, with an incidence of approximately 1/1,000 pregnancies resulting from IVF.<sup>394</sup> The cause is unknown, but over two-thirds of women with cervical pregnancies have had a previous uterine curettage or cesarean delivery, suggesting some association with prior surgical trauma to the uterus or cervix.<sup>392,393</sup>

Painless vaginal bleeding is the classical symptom of cervical pregnancy. On clinical examination, the cervix is usually distended, appearing hyperemic or cyanotic, soft, and enlarged out of proportion to the uterus (“hourglass” cervix).<sup>392</sup> Most often, the diagnosis has been incidental to routine ultrasonography or curettage for an assumed incomplete abortion. Early diagnosis is based on ultrasonographic observations of an endocervical gestational sac with associated trophoblastic invasion below a closed internal cervical os, with a normal endometrial thickness<sup>392,395,396</sup>; focally increased blood flow detected by color and pulsed Doppler ultrasonography or cardiac activity confirms the diagnosis.<sup>395,397,398</sup>

In hemodynamically stable women with cervical pregnancies, conservative treatment is aimed at preserving the uterus and reducing the substantial risks of catastrophic hemorrhage. A wide variety of management strategies have been employed successfully. Local and/or systemic treatment with methotrexate has been successful in over 80% of treated women with cervical pregnancies,<sup>392,399</sup> but experience is limited to case reports and small series.<sup>400,401,402</sup> Other medical treatment strategies include direct local injection of potassium chloride when embryonic heart activity is present.<sup>403,404,405</sup>

Traditional treatment for cervical pregnancy was curettage and hysterectomy, when necessary for control of hemorrhage. Methods aimed at minimizing that risk have included cervical cerclage, intracervical injection of vasopressin, and transvaginal ligation of the cervical branches of the uterine arteries. Similar measures as well as intracervical balloon tamponade and bilateral uterine or internal iliac artery ligation have been used to control postoperative bleeding. More recently, uterine artery embolization (UAE) has been used both preoperatively and postoperatively to prevent or control hemorrhage,<sup>392,403,404</sup> but experience to date is insufficient to warrant its routine recommendation.

# Cesarean Scar Pregnancy

Ectopic pregnancies in a cesarean scar account for approximately 6% of all ectopic pregnancies among women with a previous cesarean delivery (**Figure 33.1**).<sup>406,407,408</sup> The number of reports has increased dramatically in the last 20 years. In 2002, a review paper on cesarean scar pregnancies reported 19 cases described in the literature.<sup>409</sup> Since then, an increasing number of case reports and case series on this topic have been published, and by 2012, the numbers had escalated to 44, 483, and 107 cases, respectively, reported in the United States, China, and the United Kingdom.<sup>410</sup> This uptrend in the number of reported cases may be related to the true increase in the incidence of cesarean scar pregnancies or reflect increasing awareness of the condition among obstetricians and gynecologists.

The exact mechanism for abnormal implantation is unknown, but is thought to be due to the migration of a blastocyst through either a wedge-shaped myometrial scar defect, a scar dehiscence, or through a microscopic tract within the scar.<sup>411,412</sup>

Since scar and fistula formation can develop following other uterine surgeries, scar pregnancies have also been reported after previous dilation and curettage, myomectomy, metroplasty, hysteroscopy, and manual removal of the placenta.<sup>411,412</sup> In addition to prior uterine surgery, other risk factors include history of placental pathology, ectopic pregnancy, adenomyosis, and IVF.<sup>413,414</sup>

It has been suggested that the risk of CSP increases with the number of previous cesarean sections, possibly due to increased scar surface area or risk of scar defect.<sup>413</sup> However, other studies have found no such correlation. A recent systematic review found that over half (52%) of reported cases occur in women with only one prior cesarean delivery, 36% after two, and 12% after three or more prior cesarean sections.<sup>407</sup> Limited data are available on the association between cesarean scar ectopic and indication for cesarean delivery; however, cesarean section for breech presentation is most frequently identified as a possible risk factor.<sup>407,413</sup> No data are available in the literature regarding surgical technique (i.e., single- vs. double-layered closure) or interpregnancy interval as possible risk factors for cesarean scar pregnancy.

The clinical presentation of women with cesarean scar ectopic pregnancies varies widely, from vaginal bleeding, with or without pain, to uterine rupture and hemorrhagic shock.<sup>415</sup> Diagnosis usually is made by ultrasonography in the first trimester, revealing an enlarged hysterotomy scar with an associated mass that extends beyond the external contour of the uterus.<sup>416,417</sup> Other findings include an empty uterine cavity and cervical canal, without contact with the gestational sac; presence of a trophoblast in the anterior part of the uterine isthmus or between the bladder and the anterior uterine wall; and

absence of, thinning, or visible defect in the myometrium between the bladder and the sac.<sup>411,412</sup>

Due to the risk of life-threatening complications, including uterine rupture and hemorrhage, pregnancy termination is generally recommended in the first trimester. Treatment goals include ending the pregnancy prior to rupture, removing the sac, and preserving future fertility if desired by the patient. **The best management for cesarean scar ectopic pregnancies has not yet been defined.**

A vast variety of treatment modalities have been proposed over the last few years. A systematic review from 2012 mentioned 31 different treatment modalities for managing cesarean scar ectopic pregnancy.<sup>410,418</sup> Identification of treatment of choice should reflect a balance between minimal necessary intervention and maximal efforts to reduce the risk of complications. It should account for clinical presentation and level of suspicion for ongoing or risk of uterine rupture, gestational age, trend of laboratory values, imaging characteristics, patients' preference and plans for future fertility, as well as availability of the appropriate equipment and qualified staff. A more recent systematic review recommended five treatment modalities as being most effective and associated with the least number of complications and need for additional therapy<sup>419</sup>; these approaches were resection through a transvaginal approach, laparoscopy, UAE in combination with dilation and curettage, and hysteroscopy. Notably, use of systemic methotrexate alone or in combination with local injection was associated with severe complications in 13% of the cases and need for additional treatment in 15% (systemic and local) and 25% (systemic only).<sup>419</sup>

Use of UAE has been effectively employed to decrease the risk of hemorrhage.<sup>420,421,422,423</sup> In a randomized trial involving 72 women with cesarean scar pregnancy treated with UAE or methotrexate before dilation and curettage, UAE was associated with significantly less blood loss and a shorter hospital stay.<sup>424</sup> Intrauterine placement of a cervical ripening double-balloon catheter is a novel approach that has been effective in achieving compression of the gestational sac and its blood supply and has shown promising results in managing cesarean scar pregnancies.<sup>425</sup> Expectant management of cesarean scar pregnancies has been reported.<sup>418,426</sup> A recent meta-analysis and systematic review examined outcomes in 69 cases of cesarean scar pregnancy that were managed expectantly across 17 studies; fetal cardiac activity was evident in 75% (52/69) of the cases. This review established that in the presence of fetal cardiac activity, expectant management approach to cesarean scar pregnancy is fraught with a high likelihood of a variety of maternal complications that include severe hemorrhage, abnormally adherent placenta, uterine rupture, and a need for hysterectomy. In contrast, when there is absent fetal cardiac activity, a cesarean scar early pregnancy is likely to result in an uncomplicated miscarriage, as was observed in a majority

(69.1%; 95% CI = 47.4–87.1%) of cases; an intervention (surgical or medical) was required in almost 31% (95% CI = 12.9–52.6%). Uterine rupture was uncommon in the absence of fetal cardiac activity (in only 13.4% of cases, 95% CI = 2.7–30.3%).

High incidence of abnormal placental invasion is described in cesarean scar pregnancies. In two separate studies, each reporting on 10 patients managed expectantly, a diagnosis of morbidly adherent placenta was confirmed at the time of delivery by cesarean section.<sup>427,428</sup> These data identify cesarean scar site as a precursor for abnormal placental invasion.

After successful treatment of a cesarean scar pregnancy, recurrent cesarean scar implantation, successful intrauterine pregnancies, placenta accreta, and uterine rupture (resulting in maternal death) all have been reported.<sup>429,430,431</sup> The exact risk of recurrence of CSP is unknown; however, some studies quote the rate of recurrence 4–15.6%.<sup>413,432,433</sup> Consequently, early ultrasonography to establish the site of implantation is indicated in subsequent pregnancies.<sup>434</sup>

# REFERENCES

1. **Graham H**, *Eternal Eve, The History of Gynaecology & Obstetrics*, Doubleday & Company, Inc., Garden City, 1951.
2. **Harbert WW**, A case of extra-uterine pregnancy, *West J Med Surg* 3:110, 1849.
3. **Parry JS**, *Extra-uterine Pregnancy: Its Causes, Species, Pathological Anatomy, Clinical History, Diagnosis, Prognosis, and Treatment*, H.C. Lea, Philadelphia, PA, 1876.
4. **Tait RL**, Five cases of extra-uterine pregnancy operated upon at the time of rupture, *Br Med J* I:1250, 1884.
5. **Goldner TE, Lawson HW, Xia Z, Atrash HK**, Surveillance for ectopic pregnancy—United States, 1970–1989, *MMWR Surveill Summ* 42:73, 1993.
6. **Centers for Disease Control and Prevention**, Ectopic pregnancy—United States, 1990–1992, *MMWR Morb Mortal Wkly Rep* 44:46, 1995.
7. **Stovall TG, Ling FW, Buster JE**, Outpatient chemotherapy of unruptured ectopic pregnancy, *Fertil Steril* 51:435, 1989.
8. **Ory SJ**, New options for diagnosis and treatment of ectopic pregnancy, *JAMA* 267:534, 1992.
9. **Carson SA, Buster JE**, Ectopic pregnancy, *N Engl J Med* 329:1174, 1993.
10. **Zane SB, Kieke BA Jr, Kendrick JS, Bruce C**, Surveillance in a time of changing health care practices: estimating ectopic pregnancy incidence in the United States, *Matern Child Health J* 6:227, 2002.
11. **Chang J, Elam-Evans LD, Berg CJ, Herndon J, Flowers L, Seed KA, Syverson CJ**, Pregnancy-related mortality surveillance—United States, 1991–1999, *MMWR Surveill Summ* 52:1, 2003.
12. **Barnhart KT**, Clinical practice. Ectopic pregnancy, *N Engl J Med* 361:379, 2009.
13. **Van Den Eeden SK, Shan J, Bruce C, Glasser M**, Ectopic pregnancy rate and treatment utilization in a large managed care organization, *Obstet Gynecol* 105:1052, 2005.
14. **Stovall TG, Ling FW, Andersen RN, Buster JE**, Improved sensitivity and specificity of a single measurement of serum progesterone over serial quantitative beta-human chorionic gonadotrophin in screening for ectopic pregnancy, *Hum Reprod* 7:723, 1992.
15. **Barnhart KT, Simhan H, Kamelle SA**, Diagnostic accuracy of ultrasound above and below the beta-hCG discriminatory zone, *Obstet Gynecol* 94:583, 1999.
16. **Storeide O, Veholmen M, Eide M, Bergsjø P, Sandvei R**, The incidence of ectopic pregnancy in Hordaland County, Norway 1976–1993, *Acta Obstet Gynecol Scand* 76:345, 1997.
17. **Nybo Andersen AM, Wohlfahrt J, Christens P, Olsen J, Melbye M**, Maternal age and fetal loss: population based register linkage study, *Br Med J* 320:1708, 2000.
18. **Barnhart KT, Sammel MD, Gracia CR, Chittams J, Hummel AC, Shaunik A**, Risk factors for ectopic pregnancy in women with symptomatic first-trimester pregnancies, *Fertil Steril* 86:36, 2006.
19. **American College of Obstetricians and Gynecologists**, ACOG Practice Bulletin No. 94: medical management of ectopic pregnancy, *Obstet Gynecol* 111:1479, 2008.
20. **Gaskins AJ, Missmer SA, Rich-Edwards JW, Williams PL, Souter I, Chavarro JE**, Demographic, lifestyle, and reproductive risk factors for ectopic pregnancy, *Fertil Steril* 110(7):1328, 2018. doi:10.1016/j.fertnstert.2018.08.022.
21. **Ankum WM, Mol BWJ, Van der Veen F, Bossuyt PMM**, Risk factors for ectopic pregnancy: a meta-analysis, *Fertil Steril* 65:1093, 1996.
22. **Bouyer J, Coste J, Shojaei T, Pouly JL, Fernandez H, Gerbaud L, Job-Spira N**, Risk factors for ectopic pregnancy: a comprehensive analysis based on a large case-control, population-based study in France, *Am J Epidemiol* 157:185, 2003.
23. **Murray H, Baakdah H, Bardell T, Tulandi T**, Diagnosis and treatment of ectopic pregnancy, *CMAJ* 173:905, 2005.
24. **Skjeldestad FE, Hadgu A, Eriksson N**, Epidemiology of repeat ectopic pregnancy: a population-based prospective cohort study, *Obstet Gynecol* 91:129, 1998.
25. **Schoen JA, Nowak RJ**, Repeat ectopic pregnancy: a 16-year clinical survey, *Obstet Gynecol* 45:542, 1975.

26. **Hallatt JG**, Repeat ectopic pregnancy: a study of 123 consecutive cases, *Am J Obstet Gynecol* 122:520, 1975.
27. **Sandvei R, Bergsjø P, Ulstein M, Steier JA**, Repeat ectopic pregnancy. A twenty-year hospital survey, *Acta Obstet Gynecol Scand* 66:35, 1987.
28. **Seeber BE, Barnhart KT**, Suspected ectopic pregnancy, *Obstet Gynecol* 107:399, 2006.
29. **Yao M, Tulandi T**, Current status of surgical and nonsurgical management of ectopic pregnancy, *Fertil Steril* 67:421, 1997.
30. **Hajenius PJ, Mol F, Mol BW, Bossuyt PM, Ankum WM, van der Veen F**, Interventions for tubal ectopic pregnancy, *Cochrane Database Syst Rev* CD000324, 2007.
31. **Mol F, Mol BW, Ankum WM, van der Veen F, Hajenius PJ**, Current evidence on surgery, systemic methotrexate and expectant management in the treatment of tubal ectopic pregnancy: a systematic review and meta-analysis, *Hum Reprod Update* 14:309, 2008.
32. **Job-Spira N, Fernandez H, Bouyer J, Pouly JL, Germain E, Coste J**, Ruptured tubal ectopic pregnancy: risk factors and reproductive outcome: results of a population-based study in France, *Am J Obstet Gynecol* 180:938, 1999.
33. **Svensson L, Mardh PA, Ahlgren M, Nordenskjold F**, Ectopic pregnancy and antibodies to *Chlamydia trachomatis*, *Fertil Steril* 44:313, 1985.
34. **Kihlstrom E, Lindgren R, Ryden G**, Antibodies to *Chlamydia trachomatis* in women with infertility, pelvic inflammatory disease and ectopic pregnancy, *Eur J Obstet Gynecol Reprod Biol* 35:199, 1990.
35. **Odland JO, Anestad G, Rasmussen S, Lundgren R, Dalaker K**, Ectopic pregnancy and chlamydial serology, *Int J Gynaecol Obstet* 43:271, 1993.
36. **Chow JM, Yonekura L, Richwald GA, Greenland S, Sweet RL, Schachter J**, The association between *Chlamydia trachomatis* and ectopic pregnancy: a matched-pair, case-control study, *JAMA* 263:3164, 1990.
37. **Hillis SD, Owens LM, Marchbanks PA, Amsterdam LF, Mac Kenzie WR**, Recurrent chlamydial infections increase the risks of hospitalization for ectopic pregnancy and pelvic inflammatory disease, *Am J Obstet Gynecol* 176:103, 1997.
38. **Westrom L, Joesoef R, Reynolds G, Hagdu A, Thompson SE**, Pelvic inflammatory disease and fertility. A cohort study of 1,844 women with laparoscopically verified disease and 657 control women with normal laparoscopic results, *Sex Transm Dis* 19:185, 1992.
39. **Goldberg JM, Falcone T**, Effect of diethylstilbestrol on reproductive function, *Fertil Steril* 72:1, 1999.
40. **Kaufman RH, Adam E, Hatch EE, Noller K, Herbst AL, Palmer JR, Hoover RN**, Continued follow-up of pregnancy outcomes in diethylstilbestrol-exposed offspring, *Obstet Gynecol* 96:483, 2000.
41. **DeCherney AH, Cholst I, Naftolin F**, Structure and function of the fallopian tubes following exposure to diethylstilbestrol (DES) during gestation, *Fertil Steril* 36:741, 1981.
42. **Haney AF, Newbold RR, Fetter BF, McLachlan JA**, Paraovarian cysts associated with prenatal diethylstilbestrol exposure. Comparison of the human with a mouse model, *Am J Pathol* 124:405, 1986.
43. **Herbst AL, Ulfelder H, Poskanzer DC**, Adenocarcinoma of the vagina. Association of maternal stilbestrol therapy with tumor appearance in young women, *N Engl J Med* 284:878, 1971.
44. **WHO Special Programme of Research, Development and Research Training in Human Reproduction, Task Force on Intrauterine Devices for Fertility Regulation**, A multinational case-control study of ectopic pregnancy, *Clin Reprod Fertil* 3:131, 1985.
45. **Franks AL, Beral V, Cates W Jr, Hogue CJ**, Contraception and ectopic pregnancy risk, *Am J Obstet Gynecol* 163:1120, 1990.
46. **Mol BW, Ankum WM, Bossuyt PM, Van der Veen F**, Contraception and the risk of ectopic pregnancy: a meta-analysis, *Contraception* 52:337, 1995.
47. **Furlong LA**, Ectopic pregnancy risk when contraception fails. A review, *J Reprod Med* 47:881, 2002.
48. **Edelman DA, Porter CW**, The intrauterine device and ectopic pregnancy, *Contraception* 36:85, 1987.
49. **Sivin I, el Mahgoub S, McCarthy T, Mishell DR Jr, Shoupe D, Alvarez F, Brache V, Jimenez E, Diaz J, Faundes A, Diaz MM, Coutinho E, Mattos CER, Diaz S, Pavez M, Stern J**, Long-term contraception with the levonorgestrel 20 mcg/day (LNg 20) and the copper T 380Ag intrauterine devices: a five-year randomized study, *Contraception* 42:361, 1990.



50. **Sivin I, Stern J, Coutinho E, Mattos CE, el Mahgoub S, Diaz S, Pavez M, Alvarez F, Brache V, Thevenin F, Diaz J, Faundes A, Diaz MM, McCarthy T, Mishell DR, Shoupe D**, Prolonged intrauterine contraception: a seven-year randomized study of the levonorgestrel 20 mcg/day (LNg 20) and the Copper T380 Ag IUDS, *Contraception* 44:473, 1991.
51. **Sivin I, Stern J; International Committee for Contraception Research**, Health during prolonged use of levonorgestrel 20 mg/d and the copper TCu 380 Ag intrauterine contraceptive devices: a multicenter study, *Fertil Steril* 61:70, 1994.
52. **Andersson K, Odland V, Rybo G**, Levonorgestrel-releasing and copper-releasing (Nova T) IUDs during five years of use: a randomized comparative trial, *Contraception* 49:56, 1994.
53. **Cox M, Blacksell SE**, Clinical performance of the Nova-T380 IUD in routine use by the UK Family Planning and Reproductive Health Research Network: 12-month report, *Br J Fam Plann* 26:148, 2000.
54. **Cox M, Blacksell S**, Clinical performance of the levonorgestrel intra-uterine system in routine use by the UK Family Planning and Reproductive Health Research Network: 12-month report, *Br J Fam Plann* 26:143, 2000.
55. **Backman T, Rauramo I, Huhtala S, Koskenvuo M**, Pregnancy during the use of levonorgestrel intrauterine system, *Am J Obstet Gynecol* 190:50, 2004.
56. **Ganacharya S, Bhattoa HP, Batar I**, Ectopic pregnancy among non-medicated and copper-containing intrauterine device users: a 10-year follow-up, *Eur J Obstet Gynecol Reprod Biol* 111:78, 2003.
57. **Peterson HB, Xia Z, Hughes JM, Wilcox LS, Tylor LR, Trussell J; for the U.S. Collaborative Review of Sterilization Working Group**, The risk of pregnancy after tubal sterilization: findings from the U.S. Collaborative Review of Sterilization, *Am J Obstet Gynecol* 174:1161, 1996.
58. **McCausland A**, High rate of ectopic pregnancy following laparoscopic tubal coagulation failure, *Am J Obstet Gynecol* 136:977, 1980.
59. **Chi I-c, Laufe LE, Atwed R**, Ectopic pregnancy following female sterilization procedures, *Adv Plann Parenthood* 16:52, 1981.
60. **Peterson HB, Xia Z, Hughes JM, Wilcox LS, Tylor LR, Trussell J; for the U.S. Collaborative Review of Sterilization Working Group**, The risk of ectopic pregnancy after tubal sterilization, *N Engl J Med* 336:762, 1997.
61. **Holt V, Chu J, Daling JR, Stergachis AS, Weiss NS**, Tubal sterilization and subsequent ectopic pregnancy, *JAMA* 266:242, 1991.
62. **Nielsen CL, Miller L**, Ectopic gestation following emergency contraceptive pill administration, *Contraception* 62:275, 2000.
63. **Jian Z, Linan C**, Ectopic gestation following emergency contraception with levonorgestrel, *Eur J Contracept Reprod Health Care* 8:225, 2003.
64. **Sheffer-Mimouni G, Pazner D, Maslovitch S, Lessing JB, Gamzu R**, Ectopic pregnancies following emergency levonorgestrel contraception, *Contraception* 67:267, 2003.
65. **Grimes DA, Raymond EG**, Emergency contraception, *Ann Intern Med* 137:180, 2002.
66. **Shao EX, Hopper K, McKnoulty M, Kothari A**, A systematic review of ectopic pregnancy after hysterectomy, *Int J Gynaecol Obstet* 141(2):159, 2018. doi:10.1002/ijgo.12385.
67. **Thorburn J, Philipson M, Lindblom B**, Background factors of ectopic pregnancy. II. Risk estimation by means of a logistic model, *Eur J Obstet Gynecol Reprod Biol* 23:333, 1986.
68. **Yang CP, Chow WH, Daling JR, Weiss NS, Moore DE**, Does prior infertility increase the risk of tubal pregnancy?, *Fertil Steril* 48:62, 1987.
69. **Tuomivaara L, Kauppila A**, Ectopic pregnancy: a case-control study of aetiological risk factors, *Arch Gynecol Obstet* 243:5, 1988.
70. **Varma TR, Patel RH, Bhathenia RK**, Outcome of pregnancy after infertility, *Acta Obstet Gynecol Scand* 67:115, 1988.
71. **Nordenskjold F, Ahlgren M**, Risk factors in ectopic pregnancy. Results of a population-based case-control study, *Acta Obstet Gynecol Scand* 70:575, 1991.
72. **Fernandez H, Coste J, Job-Spira N**, Controlled ovarian hyperstimulation as a risk factor for ectopic pregnancy, *Obstet Gynecol* 78:656, 1991.

73. **Marcus SF, Brinsden PR**, Analysis of the incidence and risk factors associated with ectopic pregnancy following in-vitro fertilization and embryo transfer, *Hum Reprod* 10:199, 1995.
74. **Braude P, Rowell P**, Assisted conception. III—problems with assisted conception, *Br Med J* 327:920, 2003.
75. **Steptoe PC, Edwards RG**, Reimplantation of a human embryo with subsequent tubal pregnancy, *Lancet* 1:880, 1976.
76. **Clayton HB, Schieve LA, Peterson HB, Jamieson DJ, Reynolds MA, Wright VC**, Ectopic pregnancy risk with assisted reproductive technology procedures, *Obstet Gynecol* 107:595, 2006.
77. **Xing W, Ou J, Cai L**, Thawed embryo transfer and ectopic pregnancy: a meta-analysis, *Arch Gynecol Obstet* 297(6):1345, 2018. doi:10.1007/s00404-018-4724-6.
78. **Knutzen V, Stratton CJ, Sher G, McNamee PI, Huang TT, Soto-Albors C**, Mock embryo transfer in early luteal phase, the cycle before in vitro fertilization and embryo transfer: a descriptive study, *Fertil Steril* 57:156, 1992.
79. **Nazari A, Askari HA, Check JH, O'Shaughnessy A**, Embryo transfer technique as a cause of ectopic pregnancy in in vitro fertilization, *Fertil Steril* 60:919, 1993.
80. **Lesny P, Killick SR, Robinson J, Maguiness SD**, Transcervical embryo transfer as a risk factor for ectopic pregnancy, *Fertil Steril* 72:305, 1999.
81. **Reece EA, Petrie RH, Sirmans MF, Finster M, Todd WD**, Combined intrauterine and extrauterine gestations: a review, *Am J Obstet Gynecol* 146:323, 1983.
82. **Lemus JF**, Ectopic pregnancy: an update, *Curr Opin Obstet Gynecol* 12:369, 2000.
83. **Maymon R, Shulman A**, Controversies and problems in the current management of tubal pregnancy, *Hum Reprod Update* 2:541, 1996.
84. **Zhang B, Cui L, Tang R, Ding L, Yan L, Chen ZJ**, Reduced ectopic pregnancy rate on day 5 embryo transfer compared with day 3: a meta-analysis, *PLoS One* 12(1):e0169837, 2017. doi:10.1371/journal.pone.0169837.
85. **Centers for Disease Control and Prevention**, 2007 Assisted Reproductive Technology Success Rates. National Summary and Fertility Clinic Reports, Author, Atlanta, GA, 2009.
86. **van Seeters JAH, Chua SJ, Mol BWJ, Koks CAM**, Tubal anastomosis after previous sterilization: a systematic review, *Hum Reprod Update* 23(3):358, 2017. doi:10.1093/humupd/dmx003.
87. **Saraiya M, Berg CJ, Kendrick JS, Strauss LT, Atrash HK, Ahn YW**, Cigarette smoking as a risk factor for ectopic pregnancy, *Am J Obstet Gynecol* 178:493, 1998.
88. **Knoll M, Talbot P**, Cigarette smoke inhibits oocyte cumulus complex pick-up by the oviduct in vitro independent of ciliary beat frequency, *Reprod Toxicol* 12:57, 1998.
89. **Riveles K, Iv M, Arey J, Talbot P**, Pyridines in cigarette smoke inhibit hamster oviductal functioning in picomolar doses, *Reprod Toxicol* 17:191, 2003.
90. **Bouyer J, Saurel-Cubizolles MJ, Grenier C, Aussel L, Job-Spira N**, Ectopic pregnancy and occupational exposure of hospital personnel, *Scand J Work Environ Health* 24:98, 1998.
91. **Pisarska MD, Carson SA, Buster JE**, Ectopic pregnancy, *Lancet* 351:1115, 1998.
92. **Chow WH, Daling JR, Weiss NS, Moore DE, Soderstrom R**, Vaginal douching as a potential risk factor for tubal ectopic pregnancy, *Am J Obstet Gynecol* 153:727, 1985.
93. **Wolner-Hanssen P, Eschenbach DA, Paavonen J, Stevens CE, Kiviat NB, Critchlow C, DeRouen T, Koutsky L, Holmes KK**, Association between vaginal douching and acute pelvic inflammatory disease, *JAMA* 263:1936, 1990.
94. **Daling JR, Weiss NS, Schwartz SM, Stergachis A, Wang SP, Foy H, Chu J, McKnight B, Grayston JT**, Vaginal douching and the risk of tubal pregnancy, *Epidemiology* 2:40, 1991.
95. **Phillips RS, Tuomala RE, Feldblum PJ, Schachter J, Rosenberg MJ, Aronson MD**, The effect of cigarette smoking, Chlamydia trachomatis infection, and vaginal douching on ectopic pregnancy, *Obstet Gynecol* 79:85, 1992.
96. **Kendrick JS, Atrash HK, Strauss LT, Gargiullo PM, Ahn YW**, Vaginal douching and the risk of ectopic pregnancy among black women, *Am J Obstet Gynecol* 176:991, 1997.
97. **Zhang J, Thomas AG, Leybovich E**, Vaginal douching and adverse health effects: a meta-analysis, *Am J*

Public Health 87:1207, 1997.

98. **Monif GR**, The great douching debate: to douche, or not to douche, *Obstet Gynecol* 94:630, 1999.
99. **Banerjee A, Prateek S, Malik S, Dhingra D**, Genital tuberculosis in adolescent girls from low socioeconomic status with acute ectopic pregnancy presenting at a tertiary care hospital in urban Northern India: are we missing an opportunity to treat? *Arch Gynecol Obstet* 286(6):1477, 2012. doi:10.1007/s00404-012-2487-z.
100. **de Silva PS, Hansen HH, Wehberg S, Friedman S, Nørgård BM**, Risk of ectopic pregnancy in women with inflammatory bowel disease: a 22-year nationwide cohort study, *Clin Gastroenterol Hepatol* 16(1):83.e1, 2018. doi:10.1016/j.cgh.2017.06.054.
101. **Bolaji II, Oktaba M, Mohee K, Sze KY**, An odyssey through salpingitis isthmica nodosa, *Eur J Obstet Gynecol Reprod Biol* 184:73, 2015. doi:10.1016/j.ejogrb.2014.11.014.
102. **Breen JL**, A 21 year survey of 654 ectopic pregnancies, *Am J Obstet Gynecol* 106:1004, 1970.
103. **Bouyer J, Coste J, Fernandez H, Pouly JL, Job-Spira N**, Sites of ectopic pregnancy: a 10 year population-based study of 1800 cases, *Hum Reprod* 17:3224, 2002.
104. **Attar E**, Endocrinology of ectopic pregnancy, *Obstet Gynecol Clin North Am* 31:779, 2004.
105. **Green LK, Kott ML**, Histopathologic findings in ectopic tubal pregnancy, *Int J Gynecol Pathol* 8:255, 1989.
106. **Stock RJ**, Tubal pregnancy. Associated histopathology, *Obstet Gynecol Clin North Am* 18:73, 1991.
107. **Kutluay L, Vicdan K, Turan C, Batioglu S, Oguz S, Gokmen O**, Tubal histopathology in ectopic pregnancies, *Eur J Obstet Gynecol Reprod Biol* 57:91, 1994.
108. **Lopez HB, Micheelsen U, Berendtsen H, Kock K**, Ectopic pregnancy and its associated endometrial changes, *Gynecol Obstet Invest* 38:104, 1994.
109. **Senterman M, Jibodh R, Tulandi T**, Histopathologic study of ampullary and isthmic tubal ectopic pregnancy, *Am J Obstet Gynecol* 159:939, 1988.
110. **Budowick M, Johnson TR Jr, Genadry R, Parmley TH, Woodruff JD**, The histopathology of the developing tubal ectopic pregnancy, *Fertil Steril* 34:169, 1980.
111. **Dietl J, Buchholz F, Kindler PA**, Histopathology of tubal pregnancy, *Int J Gynaecol Obstet* 27:385, 1988.
112. **Cohen MA, Sauer MV**, Expectant management of ectopic pregnancy, *Clin Obstet Gynecol* 42:48, 1999.
113. **Coste J, Fernandez H, Joye N, Benifla J, Girard S, Marpeau L, Job-Spira N**, Role of chromosome abnormalities in ectopic pregnancy, *Fertil Steril* 74:1259, 2000.
114. **Burgoyne PS, Holland K, Stephens R**, Incidence of numerical chromosome anomalies in human pregnancy estimation from induced and spontaneous abortion data, *Hum Reprod* 6:555, 1991.
115. **Goddijn M, van der Veen F, Schuring-Blom GH, Ankum WM, Leschot NJ**, Cytogenetic characteristics of ectopic pregnancy, *Hum Reprod* 11:2769, 1996.
116. **Alsuleiman SA, Grimes EM**, Ectopic pregnancy: a review of 147 cases, *J Reprod Med* 27:101, 1982.
117. **Dart RG, Kaplan B, Varaklis K**, Predictive value of history and physical examination in patients with suspected ectopic pregnancy, *Ann Emerg Med* 33:283, 1999.
118. **Buckley RG, King KJ, Disney JD, Gorman JD, Klausen JH**, History and physical examination to estimate the risk of ectopic pregnancy: validation of a clinical prediction model, *Ann Emerg Med* 34:589, 1999.
119. **Taylor RN, Padula C, Goldsmith PC**, Pitfall in the diagnosis of ectopic pregnancy: immunocytochemical evaluation in a patient with false-negative serum beta-hCG levels, *Obstet Gynecol* 71:1035, 1988.
120. **Hochner-Celnikier D, Ron M, Goshen R, Azcut D, Amir G, Yagel S**, Rupture of ectopic pregnancy following disappearance of serum beta subunit of HCG, *Obstet Gynecol* 79:826, 1992.
121. **Maccato ML, Estrada R, Faro S**, Ectopic pregnancy with undetectable serum and urine beta-hCG levels and detection of beta-hCG in the ectopic trophoblast by immunocytochemical evaluation, *Obstet Gynecol* 81:878, 1993.
122. **Rotmensch S, Cole LA**, False diagnosis and needless therapy of presumed malignant disease in women with false-positive human chorionic gonadotropin concentrations, *Lancet* 355:712, 2000.
123. **Butler SA, Cole LA**, Use of heterophilic antibody blocking agent (HBT) in reducing false-positive hCG results, *Clin Chem* 47:1332, 2001.
124. **American College of Obstetricians and Gynecologists**, Avoiding inappropriate clinical decisions based on

- false-positive human chorionic gonadotropin test results, *Int J Gynaecol Obstet* 80:231, 2003.
125. **Esfandiari N, Goldberg JM**, Heterophile antibody blocking agent to confirm false positive serum human chorionic gonadotropin assay, *Obstet Gynecol* 101:1144, 2003.
  126. **Kadar N, Caldwell BV, Romero R**, A method of screening for ectopic pregnancy and its indications, *Obstet Gynecol* 58:162, 1981.
  127. **Kadar N, Romero R**, Observations on the log human chorionic gonadotropin-time relationship in early pregnancy and its practical implications, *Am J Obstet Gynecol* 157:73, 1987.
  128. **Fritz MA, Guo S**, Doubling time of human chorionic gonadotropin (hCG) in early normal pregnancy: relationship to hCG concentration and gestational age, *Fertil Steril* 47:584, 1987.
  129. **Kadar N, Freedman M, Zacher M**, Further observations on the doubling time of human chorionic gonadotropin in early asymptomatic pregnancies, *Fertil Steril* 54:783, 1990.
  130. **Pittaway DE, Reish RL, Wentz AC**, Doubling times of human chorionic gonadotropin increase in early viable intrauterine pregnancies, *Am J Obstet Gynecol* 152:299, 1985.
  131. **Barnhart KT, Sammel MD, Rinaudo PF, Zhou L, Hummel AC, Guo W**, Symptomatic patients with an early viable intrauterine pregnancy: HCG curves redefined, *Obstet Gynecol* 104:50, 2004.
  132. **Barnhart KT, Guo W, Cary MS, Morse CB, Chung K, Takacs P, Senapati S, Sammel MD**, Differences in serum human chorionic gonadotropin rise in early pregnancy by race and value at presentation, *Obstet Gynecol* 128(3):504, 2016.
  133. **Silva C, Sammel MD, Zhou L, Gracia C, Hummel AC, Barnhart K**, Human chorionic gonadotropin profile for women with ectopic pregnancy, *Obstet Gynecol* 107:605, 2006.
  134. **Barnhart K, Sammel MD, Chung K, Zhou L, Hummel AC, Guo W**, Decline of serum human chorionic gonadotropin and spontaneous complete abortion: defining the normal curve, *Obstet Gynecol* 104:975, 2004.
  135. **Shepherd RW, Patton PE, Novy MJ, Burry KA**, Serial beta-hCG measurements in the early detection of ectopic pregnancy, *Obstet Gynecol* 75:417, 1990.
  136. **Letterie GS, Hibbert M**, Serial serum human chorionic gonadotropin (hCG) levels in ectopic pregnancy and first trimester miscarriage, *Arch Gynecol Obstet* 263:168, 2000.
  137. **Doubilet PM, Benson CB, Bourne T, Blaivas M; Society of Radiologists in Ultrasound Multispecialty Panel on Early First Trimester Diagnosis of Miscarriage and Exclusion of a Viable Intrauterine Pregnancy; Barnhart KT, Benacerraf BR, Brown DL, Filly RA, Fox JC, Goldstein SR, Kendall JL, Lyons EA, Porter MB, Pretorius DH, Timor-Tritsch IE**, Diagnostic criteria for nonviable pregnancy early in the first trimester, *N Engl J Med* 369(15):1443, 2013. doi:10.1056/NEJMra1302417.
  138. **Mol BW, van der Veen F, Hajenius PJ, Engelsbel S, Ankum WM, Hogerzeil HV, Hemrika DJ, Bossuyt PM**, Diagnosis of ectopic pregnancy after in vitro fertilization and embryo transfer, *Fertil Steril* 68:1027, 1997.
  139. **Chung K, Sammel MD, Coutifaris C, Chalian R, Lin K, Castelbaum AJ, Freedman MF, Barnhart KT**, Defining the rise of serum HCG in viable pregnancies achieved through use of IVF, *Hum Reprod* 21:823, 2006.
  140. **Dickey RP, Taylor SN, Lu PY, Sartor BM, Storment JM, Rye PH, Pelletier WD, Zender JL, Matulich EM**, Spontaneous reduction of multiple pregnancy: incidence and effect on outcome, *Am J Obstet Gynecol* 186:77, 2002.
  141. **Goldstein SR, Wolfson R**, Endovaginal ultrasonographic measurement of early embryonic size as a means of assessing gestational age, *J Ultrasound Med* 13:27, 1994.
  142. **Bradley WG, Fiske CE, Filly RA**, The double sac sign of early intrauterine pregnancy: use in exclusion of ectopic pregnancy, *Radiology* 143:223, 1982.
  143. **Rossavik IK, Torjusen GO, Gibbons WE**, Conceptual age and ultrasound measurements of gestational sac and crown-rump length in in vitro fertilization pregnancies, *Fertil Steril* 49:1012, 1988.
  144. **Hadlock FP, Shah YP, Kanon DJ, Lindsey JV**, Fetal crown-rump length: reevaluation of relation to menstrual age (5–18 weeks) with high-resolution real-time US, *Radiology* 182:501, 1992.
  145. **Goldstein SR**, Significance of cardiac activity on endovaginal ultrasound in very early embryos, *Obstet Gynecol* 80:670, 1992.
  146. **Levi CS, Lyons EA, Zheng XH, Lindsay DJ, Holt SC**, Endovaginal US: demonstration of cardiac activity in

- embryos of less than 5.0 mm in crown-rump length, *Radiology* 176:71, 1990.
147. **Brown DL, Emerson DS, Felker RE, Cartier MS, Smith WC**, Diagnosis of early embryonic demise by endovaginal sonography, *J Ultrasound Med* 9:631, 1990.
  148. **Condous G, Okaro E, Khalid A, Lu C, Van Huffel S, Timmerman D, Bourne T**, The accuracy of transvaginal ultrasonography for the diagnosis of ectopic pregnancy prior to surgery, *Hum Reprod* 20:1404, 2005.
  149. **Kirk E, Papageorghiou AT, Condous G, Tan L, Bora S, Bourne T**, The diagnostic effectiveness of an initial transvaginal scan in detecting ectopic pregnancy, *Hum Reprod* 22:2824, 2007.
  150. **Brown DL, Doubilet PM**, Transvaginal sonography for diagnosing ectopic pregnancy: positivity criteria and performance characteristics, *J Ultrasound Med* 13:259, 1994.
  151. **Shapiro BS, Escobar M, Makuch R, Lavy G, DeCherney AH**, A model-based prediction for transvaginal ultrasonographic identification of early intrauterine pregnancy, *Am J Obstet Gynecol* 166:1495, 1992.
  152. **Rowling SE, Langer JE, Coleman BG, Nisenbaum HL, Horii SC, Arger PH**, Sonography during early pregnancy: dependence of threshold and discriminatory values on transvaginal transducer frequency, *Am J Roentgenol* 172:983, 1999.
  153. **Barnhart K, Mennuti MT, Benjamin I, Jacobson S, Goodman D, Coutifaris C**, Prompt diagnosis of ectopic pregnancy in an emergency department setting, *Obstet Gynecol* 84:1010, 1994.
  154. **Shalev E, Yarom I, Bustan M, Weiner E, Ben-Shlomo I**, Transvaginal sonography as the ultimate diagnostic tool for the management of ectopic pregnancy: experience with 840 cases, *Fertil Steril* 69:62, 1998.
  155. **Condous G, Lu C, Van Huffel SV, Timmerman D, Bourne T**, Human chorionic gonadotrophin and progesterone levels in pregnancies of unknown location, *Int J Gynaecol Obstet* 86:351, 2004.
  156. **Kadar N, Bohrer M, Kemmann E, Sheldon R**, The discriminatory human chorionic gonadotropin zone for endovaginal sonography: a prospective, randomized study, *Fertil Steril* 61:1016, 1994.
  157. **Mol BW, Hajenius PJ, Engelsbel S, Ankum WM, van der Veen F, Hemrika DJ, Bossuyt PM**, Are gestational age and endometrial thickness alternatives for serum human chorionic gonadotropin as criteria for the diagnosis of ectopic pregnancy?, *Fertil Steril* 72:643, 1999.
  158. **Fleischer AC, Pennell RG, McKee MS, Worrell JA, Keefe B, Herbert CM, Hill GA, Cartwright PS, Kepple DM**, Ectopic pregnancy: features at transvaginal sonography, *Radiology* 174:375, 1990.
  159. **Sadek AL, Schiotz HA**, Transvaginal sonography in the management of ectopic pregnancy, *Acta Obstet Gynecol Scand* 74:293, 1995.
  160. **Gamzu R, Almog B, Levin Y, Pauzner D, Lessing JB, Jaffa A, Bar-Am A**, The ultrasonographic appearance of tubal pregnancy in patients treated with methotrexate, *Hum Reprod* 17:2585, 2002.
  161. **Gabrielli S, Romero R, Pilu G, Pavani A, Capelli M, Milano V, Bevini M, Bovicelli L**, Accuracy of transvaginal ultrasound and serum hCG in the diagnosis of ectopic pregnancy, *Ultrasound Obstet Gynecol* 2:110, 1992.
  162. **Mol BW, Hajenius PJ, Engelsbel S, Ankum WM, Van der Veen F, Hemrika DJ, Bossuyt PM**, Serum human chorionic gonadotropin measurement in the diagnosis of ectopic pregnancy when transvaginal sonography is inconclusive, *Fertil Steril* 70:972, 1998.
  163. **Spandorfer SD, Barnhart KT**, Endometrial stripe thickness as a predictor of ectopic pregnancy, *Fertil Steril* 66:474, 1996.
  164. **Mehta TS, Levine D, McArdle CR**, Lack of sensitivity of endometrial thickness in predicting the presence of an ectopic pregnancy, *J Ultrasound Med* 18:117, 1999.
  165. **Seeber B, Sammel M, Zhou L, Hummel A, Barnhart KT**, Endometrial stripe thickness and pregnancy outcome in first-trimester pregnancies with bleeding, pain or both, *J Reprod Med* 52:757, 2007.
  166. **Gracia CR, Barnhart KT**, Diagnosing ectopic pregnancy: decision analysis comparing six strategies, *Obstet Gynecol* 97:464, 2001.
  167. **Banerjee S, Aslam N, Zosmer N, Woelfer B, Jurkovic D**, The expectant management of women with early pregnancy of unknown location, *Ultrasound Obstet Gynecol* 14:231, 1999.
  168. **Frates MC, Doubilet PM, Peters HE, Benson CB**, Adnexal sonographic findings in ectopic pregnancy and their correlation with tubal rupture and human chorionic gonadotropin levels, *J Ultrasound Med* 33(4):697, 2014.

doi:10.7863/ultra.33.4.697.

169. **Chambers S, Muir B, Haddad N**, Ultrasound evaluation of ectopic pregnancy including correlation with human chorionic gonadotropin levels, *Br J Radiol* 63:246, 1990.
170. **Emerson DS, Cartier MS, Altier LA, Felker RE, Smith WC, Stovall TG, Gray LA**, Diagnostic efficacy of endovaginal color Doppler flow imaging in an ectopic pregnancy screening program, *Radiology* 183:413, 1992.
171. **Pellerito JS, Taylor KJ, Quedens-Case C, Hammers LW, Scoutt LM, Ramos IM, Meyer WR**, Ectopic pregnancy: evaluation with endovaginal color flow imaging, *Radiology* 183:407, 1992.
172. **Kirchler HC, Seebacher S, Alge AA, Muller-Holzner E, Fessler S, Kollé D**, Early diagnosis of tubal pregnancy: changes in tubal blood flow evaluated by endovaginal color Doppler sonography, *Obstet Gynecol* 82:561, 1993.
173. **Atri M**, Ectopic pregnancy versus corpus luteum cyst revisited: best Doppler predictors, *J Ultrasound Med* 22:1181, 2003.
174. **Pellerito JS, Troiano RN, Quedens-Case C, Taylor KJ**, Common pitfalls of endovaginal color Doppler flow imaging, *Radiographics* 15:37, 1995.
175. **Kadar N, DeVore G, Romero R**, Discriminatory hCG zone: its use in the sonographic evaluation for ectopic pregnancy, *Obstet Gynecol* 58:156, 1981.
176. **Nyberg DA, Mack LA, Laing FC, Jeffrey RB**, Early pregnancy complications: endovaginal sonographic findings correlated with human chorionic gonadotropin levels, *Radiology* 167:619, 1988.
177. **Cacciatore B, Stenman UH, Ylostalo P**, Diagnosis of ectopic pregnancy by vaginal ultrasonography in combination with a discriminatory serum hCG level of 1000 IU/l (IRP), *Br J Obstet Gynaecol* 97:904, 1990.
178. **Paul M, Schaff E, Nichols M**, The roles of clinical assessment, human chorionic gonadotropin assays, and ultrasonography in medical abortion practice, *Am J Obstet Gynecol* 183:S34, 2000.
179. **Seeber BE, Sammel MD, Guo W, Zhou L, Hummel A, Barnhart KT**, Application of redefined human chorionic gonadotropin curves for the diagnosis of women at risk for ectopic pregnancy, *Fertil Steril* 86:454, 2006.
180. **Chapa JB, Hibbard JU, Weber EM, Abramowicz JS, Verp MS**, Prenatal diagnosis of methotrexate embryopathy, *Obstet Gynecol* 101:1104, 2003.
181. **Goffman D, Cole DS, Bobby P, Garry DJ**, Failed methotrexate termination of pregnancy: a case report, *J Perinatol* 26:645, 2006.
182. **Seidahmed MZ, Shaheed MM, Abdulbasit OB, Al Dohami H, Babiker M, Abdullah MA, Abomelha AM**, A case of methotrexate embryopathy with holoprosencephaly, expanding the phenotype, *Birth Defects Res A Clin Mol Teratol* 76:138, 2006.
183. **Adam MP, Manning MA, Beck AE, Kwan A, Enns GM, Clericuzio C, Hoyme HE**, Methotrexate/misoprostol embryopathy: report of four cases resulting from failed medical abortion, *Am J Med Genet A* 123A:72, 2003.
184. **Addar MH**, Methotrexate embryopathy in a surviving intrauterine fetus after presumed diagnosis of ectopic pregnancy: case report, *J Obstet Gynaecol Can* 26:1001, 2004.
185. **Usta IM, Nassar AH, Yunis KA, Abu-Musa AA**, Methotrexate embryopathy after therapy for misdiagnosed ectopic pregnancy, *Int J Gynaecol Obstet* 99:253, 2007.
186. **Mol BW, van Der Veen F, Bossuyt PM**, Implementation of probabilistic decision rules improves the predictive values of algorithms in the diagnostic management of ectopic pregnancy, *Hum Reprod* 14:2855, 1999.
187. **Hajenius PJ, Mol BW, Ankum WM, van der Veen F, Bossuyt PM, Lammes FB**, Suspected ectopic pregnancy: expectant management in patients with negative sonographic findings and low serum hCG concentrations, *Early Pregnancy* 1:258, 1995.
188. **Ankum WM, van der Veen F, Hamerlynck JV, Lammes FB**, Suspected ectopic pregnancy. What to do when human chorionic gonadotropin levels are below the discriminatory zone, *J Reprod Med* 40:525, 1995.
189. **Kadar N, Romero R**, Further observations on serial human chorionic gonadotropin patterns in ectopic pregnancies and spontaneous abortions, *Fertil Steril* 50:367, 1988.

190. **Barnhart KT, Katz I, Hummel A, Gracia CR**, Presumed diagnosis of ectopic pregnancy, *Obstet Gynecol* 100:505, 2002.
191. **Cacciatore B, Ylostalo P, Stenman UH, Widholm O**, Suspected ectopic pregnancy: ultrasound findings and hCG levels assessed by an immunofluorometric assay, *Br J Obstet Gynaecol* 95:497, 1988.
192. **Hahlin M, Thorburn J, Bryman I**, The expectant management of early pregnancies of uncertain site, *Hum Reprod* 10:1223, 1995.
193. **Condous G, Kirk E, Lu C, Van Calster B, Van Huffel S, Timmerman D, Bourne T**, There is no role for uterine curettage in the contemporary diagnostic workup of women with a pregnancy of unknown location, *Hum Reprod* 21:2706, 2006.
194. **Banerjee S, Aslam N, Woelfer B, Lawrence A, Elson J, Jurkovic D**, Expectant management of early pregnancies of unknown location: a prospective evaluation of methods to predict spontaneous resolution of pregnancy, *Br J Obstet Gynaecol* 108:158, 2001.
195. **Mol BW, Van der Veen F**, Results of expectant management of women early pregnancy and unknown location, *Ultrasound Obstet Gynecol* 15:265; author reply 266, 2000.
196. **Hubinont CJ, Thomas C, Schwers JF**, Luteal function in ectopic pregnancy, *Am J Obstet Gynecol* 156:669, 1987.
197. **Wang L, Warnes GM, Kirby CA, Matthews CD, Norman RJ**, Luteal function associated with single, multiple and ectopic embryo implantation in natural cycles or after ovarian hyperstimulation for in-vitro fertilization/gamete intra-fallopian transfer, *Hum Reprod* 5: 476, 1990.
198. **Mantzavinos T, Phocas I, Chrelias H, Sarandakou A, Zourlas PA**, Serum levels of steroid and placental protein hormones in ectopic pregnancy, *Eur J Obstet Gynecol Reprod Biol* 39:117, 1991.
199. **Lower AM, Yovich JL, Hancock C, Grudzinskas JG**, Is luteal function maintained by factors other than chorionic gonadotrophin in early pregnancy?, *Hum Reprod* 8:645, 1993.
200. **Sauer MV, Anderson RE, Vermesh M, Stone BA, Paulson RJ**, Spontaneously resorbing ectopic pregnancy: preservation of human chorionic gonadotropin bioactivity despite declining steroid hormone levels, *Am J Obstet Gynecol* 161:1673, 1989.
201. **Kratzer PG, Taylor RN**, Corpus luteum function in early pregnancies is primarily determined by the rate of change of human chorionic gonadotropin levels, *Am J Obstet Gynecol* 163:1497, 1990.
202. **Klein M, Graf AH, Hutter W, Hacker GW, Beck A, Staudach A, Kiss H, Egarter C, Husslein P**, Proliferative activity in ectopic trophoblastic tissue, *Hum Reprod* 10:2441, 1995.
203. **Kiss H, Klein M, Egarter C, Graf AH, Hacker G, Hutter W, Czerwenka K, Husslein P**, Proliferative cell activity in correlation to human chorionic gonadotrophin release of trophoblast tissue of tubal pregnancy, *Hum Reprod* 12:383, 1997.
204. **Johnson MR, Riddle AF, Irvine R, Sharma V, Collins WP, Nicolaidis KH, Grudzinskas JG**, Corpus luteum failure in ectopic pregnancy, *Hum Reprod* 8:1491, 1993.
205. **Alam V, Altieri E, Zegers-Hochschild F**, Preliminary results on the role of embryonic human chorionic gonadotrophin in corpus luteum rescue during early pregnancy and the relationship to abortion and ectopic pregnancy, *Hum Reprod* 14:2375, 1999.
206. **Stovall TG, Ling FW, Cope BJ, Buster JE**, Preventing ruptured ectopic pregnancy with a single serum progesterone, *Am J Obstet Gynecol* 160:1425, 1989.
207. **Mol BW, Lijmer JG, Ankum WM, van der Veen F, Bossuyt PM**, The accuracy of single serum progesterone measurement in the diagnosis of ectopic pregnancy: a meta-analysis, *Hum Reprod* 13:3220, 1998.
208. **Buckley RG, King KJ, Disney JD, Riffenburgh RH, Gorman JD, Klausen JH**, Serum progesterone testing to predict ectopic pregnancy in symptomatic first-trimester patients, *Ann Emerg Med* 36:95, 2000.
209. **Grosskinsky CM, Hage ML, Tyrey L, Christakos AC, Hughes CL**, hCG, progesterone, alpha-fetoprotein, and estradiol in the identification of ectopic pregnancy, *Obstet Gynecol* 81:705, 1993.
210. **Dart R, Dart L, Segal M, Page C, Brancato J**, The ability of a single serum progesterone value to identify abnormal pregnancies in patients with beta-human chorionic gonadotropin values less than 1,000 mIU/mL, *Acad Emerg Med* 5:304, 1998.
211. **Gelder MS, Boots LR, Younger JB**, Use of a single random serum progesterone value as a diagnostic aid

for ectopic pregnancy, *Fertil Steril* 55:497, 1991.

212. **McCord ML, Muram D, Buster JE, Arheart KL, Stovall TG, Carson SA**, Single serum progesterone as a screen for ectopic pregnancy: exchanging specificity and sensitivity to obtain optimal test performance, *Fertil Steril* 66:513, 1996.
213. **Perkins SL, Al-Ramahi M, Claman P**, Comparison of serum progesterone as an indicator of pregnancy nonviability in spontaneously pregnant emergency room and infertility clinic patient populations, *Fertil Steril* 73:499, 2000.
214. **Stovall TG, Ling FW, Carson SA, Buster JE**, Serum progesterone and uterine curettage in differential diagnosis of ectopic pregnancy, *Fertil Steril* 57:456, 1992.
215. **Lindahl B, Ahlgren M**, Identification of chorion villi in abortion specimens, *Obstet Gynecol* 67:79, 1986.
216. **Lipscomb GH, Stovall TG, Ling FW**, Nonsurgical treatment of ectopic pregnancy, *N Engl J Med* 343:1325, 2000.
217. **Ries A, Singson P, Bidus M, Barnes JG**, Use of the endometrial pipelle in the diagnosis of early abnormal gestations, *Fertil Steril* 74:593, 2000.
218. **Barnhart KT, Gracia CR, Reindl B, Wheeler JE**, Usefulness of pipelle endometrial biopsy in the diagnosis of women at risk for ectopic pregnancy, *Am J Obstet Gynecol* 188:906, 2003.
219. **Spandorfer SD, Menzin AW, Barnhart KT, LiVolsi VA, Pfeifer SM**, Efficacy of frozen-section evaluation of uterine curettings in the diagnosis of ectopic pregnancy, *Am J Obstet Gynecol* 175:603, 1996.
220. **Heller DS, Hessami S, Cracchiolo B, Skurnick JH**, Reliability of frozen section of uterine curettings in evaluation of possible ectopic pregnancy, *J Am Assoc Gynecol Laparosc* 7:519, 2000.
221. **Yonke N, Leeman LM**, First-trimester surgical abortion technique, *Obstet Gynecol Clin North Am* 40(4):647, 2013. doi:10.1016/j.ogc.2013.08.006.
222. *Safe Abortion: Technical and Policy Guidance for Health Systems*, World Health Organization, Geneva, 2012.
223. **Insogna IG, Farland LV, Missmer SA, Ginsburg ES, Brady PC**, Outpatient endometrial aspiration: an alternative to methotrexate for pregnancy of unknown location, *Am J Obstet Gynecol* 217(2):185.e1, 2017. doi:10.1016/j.ajog.2017.04.023.
224. ACOG Practice Bulletin No. 193: tubal ectopic pregnancy, *Obstet Gynecol* 131(3):e91, 2018.
225. **Gruber K, Gelven PL, Austin RM**, Chorionic villi or trophoblastic tissue in uterine samples of four women with ectopic pregnancies, *Int J Gynecol Pathol* 16:28, 1997.
226. **Condous G, Timmerman D, Goldstein S, Valentin L, Jurkovic D, Bourne T**, Pregnancies of unknown location: consensus statement, *Ultrasound Obstet Gynecol* 28:121, 2006.
227. **Ailawadi M, Lorch SA, Barnhart KT**, Cost-effectiveness of presumptively medically treating women at risk for ectopic pregnancy compared with first performing a dilatation and curettage, *Fertil Steril* 83:376, 2005.
228. **Cacciatore B, Stenman UH, Ylostalo P**, Early screening for ectopic pregnancy in high-risk symptom-free women, *Lancet* 343:517, 1994.
229. **Mol BW, Hajenius PJ, Ankum WM, Bossuyt PM, van der Veen F**, Screening for ectopic pregnancy in symptom-free women at increased risk, *Obstet Gynecol* 89:704, 1997.
230. **Mol BW, van der Veen F, Bossuyt PM**, Symptom-free women at increased risk of ectopic pregnancy: should we screen?, *Acta Obstet Gynecol Scand* 81:661, 2002.
231. **Nielsen S, Hahlin M**, Expectant management of first-trimester spontaneous abortion, *Lancet* 345:84, 1995.
232. **Chipchase J, James D**, Randomised trial of expectant versus surgical management of spontaneous miscarriage, *Br J Obstet Gynaecol* 104:840, 1997.
233. **Blohm F, Friden B, Platz-Christensen JJ, Milsom I, Nielsen S**, Expectant management of first-trimester miscarriage in clinical practice, *Acta Obstet Gynecol Scand* 82:654, 2003.
234. **Garcia AJ, Aubert JM, Sama J, Josimovich JB**, Expectant management of presumed ectopic pregnancies, *Fertil Steril* 48:395, 1987.
235. **Ylostalo P, Cacciatore B, Sjoberg J, Kaariainen M, Tenhunen A, Stenman U-H**, Expectant management of ectopic pregnancy, *Obstet Gynecol* 80:345, 1992.
236. **Shalev E, Peleg D, Tsabari A, Romano S, Bustan M**, Spontaneous resolution of ectopic tubal pregnancy: natural history, *Fertil Steril* 63:15, 1995.



237. **Trio D, Strobelt N, Picciolo C, Lapinski R, Ghidioni A**, Prognostic factors for successful expectant management of ectopic pregnancy, *Fertil Steril* 63:469, 1995.
238. **Korhonen J, Stenman UH, Ylostalo P**, Low-dose oral methotrexate with expectant management of ectopic pregnancy, *Obstet Gynecol* 88:775, 1996.
239. **Jurkovic D, Memtsa M, Sawyer E, Donaldson AN, Jamil A, Schramm K, Sana Y, Otify M, Farahani L, Nunes N, Ambler G, Ross JA**, Single-dose systemic methotrexate vs expectant management for treatment of tubal ectopic pregnancy: a placebo-controlled randomized trial, *Ultrasound Obstet Gynecol* 49(2):171, 2017. doi:10.1002/uog.17329.
240. **Tulandi T, Hemmings R, Khalifa F**, Rupture of ectopic pregnancy in women with low and declining serum beta-human chorionic gonadotropin concentrations, *Fertil Steril* 56:786, 1991.
241. **Rantala M, Mäkinen J**, Tubal patency and fertility outcome after expectant management of ectopic pregnancy, *Fertil Steril* 68:1043, 1997.
242. **Kenigsberg D, Porte J, Hull M, Spitz IM**, Medical treatment of residual ectopic pregnancy: RU 486 and methotrexate, *Fertil Steril* 47:702, 1987.
243. **Altaras M, Cohen I, Cordoba M, Ben-Nun I, Ben-Aderet N**, Treatment of an interstitial pregnancy with actinomycin D. Case report, *Br J Obstet Gynaecol* 95:1321, 1988.
244. **Aboulghar MA, Mansour RT, Serour GI**, Transvaginal injection of potassium chloride and methotrexate for the treatment of tubal pregnancy with a live fetus, *Hum Reprod* 5:887, 1990.
245. **Lang PF, Weiss PA, Mayer HO, Haas JG, Honigl W**, Conservative treatment of ectopic pregnancy with local injection of hyperosmolar glucose solution or prostaglandin-F2 alpha: a prospective randomised study, *Lancet* 336:78, 1990.
246. **Lindblom B, Hahlin M, Lundorff P, Thorburn J**, Treatment of tubal pregnancy by laparoscope-guided injection of prostaglandin F2 alpha, *Fertil Steril* 54:404, 1990.
247. **Gazvani MR, Emery SJ**, Mifepristone and methotrexate: the combination for medical treatment of ectopic pregnancy, *Am J Obstet Gynecol* 180:1599, 1999.
248. **Stovall TG, Ling FW**, Single-dose methotrexate: an expanded clinical trial, *Am J Obstet Gynecol* 168:1759, 1993.
249. **Alexander JM, Rouse DJ, Varner E, Austin JM Jr**, Treatment of the small unruptured ectopic pregnancy: a cost analysis of methotrexate versus laparoscopy, *Obstet Gynecol* 88:123, 1996.
250. **Barnhart K, Esposito M, Coutifaris C**, An update on the medical treatment of ectopic pregnancy, *Obstet Gynecol Clin North Am* 27:653, 2000.
251. **Creinin MD, Krohn MA**, Methotrexate pharmacokinetics and effects in women receiving methotrexate 50 mg and 60 mg per square meter for early abortion, *Am J Obstet Gynecol* 177:1444, 1997.
252. **Bleyer WA**, The clinical pharmacology of methotrexate: new applications of an old drug, *Cancer* 41:36, 1978.
253. **Kooi S, Kock HC**, A review of the literature on nonsurgical treatment in tubal pregnancies, *Obstet Gynecol Surv* 47:739, 1992.
254. **Glock JL, Johnson JV, Brumsted JR**, Efficacy and safety of single-dose systemic methotrexate in the treatment of ectopic pregnancy, *Fertil Steril* 62:716, 1994.
255. **Corsan GH, Karacan M, Qasim S, Bohrer MK, Ransom MX, Kemmann E**, Identification of hormonal parameters for successful systemic single-dose methotrexate therapy in ectopic pregnancy, *Hum Reprod* 10:2719, 1995.
256. **Ransom MX, Garcia AJ, Bohrer M, Corsan GH, Kemmann E**, Serum progesterone as a predictor of methotrexate success in the treatment of ectopic pregnancy, *Obstet Gynecol* 83:1033, 1994.
257. **Stika CS, Anderson L, Frederiksen MC**, Single-dose methotrexate for the treatment of ectopic pregnancy: Northwestern Memorial Hospital three-year experience, *Am J Obstet Gynecol* 174:1840, 1996.
258. **Lipscomb GH, McCord ML, Stovall TG, Huff G, Portera SG, Ling FW**, Predictors of success of methotrexate treatment in women with tubal ectopic pregnancies, *N Engl J Med* 341:1974, 1999.
259. **Ory SJ, Villanueva AL, Sand PK, Tamura RK**, Conservative treatment of ectopic pregnancy with methotrexate, *Am J Obstet Gynecol* 154:1299, 1986.
260. **American College of Obstetricians and Gynecologists**, ACOG practice bulletin. Medical management of

- tubal pregnancy. Number 3, December 1998. Clinical management guidelines for obstetrician-gynecologists. American College of Obstetricians and Gynecologists, *Int J Gynaecol Obstet* 65:97, 1999.
261. **Stovall TG, Ling FW, Gray LA**, Single-dose methotrexate for treatment of ectopic pregnancy, *Obstet Gynecol* 77:754, 1991.
  262. **Buster JE, Pisarska MD**, Medical management of ectopic pregnancy, *Clin Obstet Gynecol* 42:23, 1999.
  263. **Shalev E, Peleg D, Bustan M, Romano S, Tsabari A**, Limited role for intratubal methotrexate treatment of ectopic pregnancy, *Fertil Steril* 63:20, 1995.
  264. **Lipscomb GH, Bran D, McCord ML, Portera JC, Ling FW**, Analysis of three hundred fifteen ectopic pregnancies treated with single-dose methotrexate, *Am J Obstet Gynecol* 178:1354, 1998.
  265. **Fernandez H, Pauthier S, Doumerc S, Lelaidier C, Olivennes F, Ville Y, Frydman R**, Ultrasound-guided injection of methotrexate versus laparoscopic salpingotomy in ectopic pregnancy, *Fertil Steril* 63:25, 1995.
  266. **Barnhart KT, Gosman G, Ashby R, Sammel M**, The medical management of ectopic pregnancy: a meta-analysis comparing “single dose” and “multidose” regimens, *Obstet Gynecol* 101:778, 2003.
  267. **Romero R, Copel JA, Kadar N, Jeanty P, Decherney A, Hobbins JC**, Value of culdocentesis in the diagnosis of ectopic pregnancy, *Obstet Gynecol* 65:519, 1985.
  268. **Vermesh M, Graczykowski JW, Sauer MV**, Reevaluation of the role of culdocentesis in the management of ectopic pregnancy, *Am J Obstet Gynecol* 162:411, 1990.
  269. **Menon S, Colins J, Barnhart KT**, Establishing a human chorionic gonadotropin cutoff to guide methotrexate treatment of ectopic pregnancy: a systematic review, *Fertil Steril* 87:481, 2007.
  270. **American Society for Reproductive Medicine**, Medical treatment of ectopic pregnancy, *Fertil Steril* 90:S206, 2008.
  271. **Sauer MV, Gorrill MJ, Rodi IA, Yeko TR, Greenberg LH, Bustillo M, Gunning JE, Buster JE**, Nonsurgical management of unruptured ectopic pregnancy: an extended clinical trial, *Fertil Steril* 48:752, 1987.
  272. **Barnhart K, Hummel AC, Sammel MD, Menon S, Jain J, Chakhtoura N**, Use of “2-dose” regimen of methotrexate to treat ectopic pregnancy, *Fertil Steril* 87:250, 2007.
  273. **American College of Obstetricians and Gynecologists**, Prevention of Rh D isoimmunization, In: *Practice Bulletin*, American College of Obstetricians and Gynecologists, Washington, 2017. (Replaces Practice Bulletin Number 4, May 1999). Available at <https://www.acog.org/443/Clinical-Guidance-and-Publications/Practice-Bulletins/Committee-on-Practice-Bulletins-Obstetrics/Prevention-of-Rh-D-Alloimmunization>
  274. **Fung Kee Fung K, Eason E, Crane J, Armson A, De La Ronde S, Farine D, Keenan-Lindsay L, Leduc L, Reid GJ, Aerde JV, Wilson RD, Davies G, Desilets VA, Summers A, Wyatt P, Young DC**, Prevention of Rh alloimmunization, *J Obstet Gynaecol Can* 25:765, 2003.
  275. **Jabara S, Barnhart KT**, Is Rh immune globulin needed in early first-trimester abortion? A review, *Am J Obstet Gynecol* 188:623, 2003.
  276. **Natale A, Candiani M, Barbieri M, Calia C, Odorizzi MP, Busacca M**, Pre- and post-treatment patterns of human chorionic gonadotropin for early detection of persistence after a single dose of methotrexate for ectopic pregnancy, *Eur J Obstet Gynecol Reprod Biol* 117:87, 2004.
  277. **Brown DL, Felker RE, Stovall TG, Emerson DS, Ling FW**, Serial endovaginal sonography of ectopic pregnancies treated with methotrexate, *Obstet Gynecol* 77:406, 1991.
  278. **Fauconnier A, Mabrouk A, Salomon LJ, Bernard JP, Ville Y**, Ultrasound assessment of haemoperitoneum in ectopic pregnancy: derivation of a prediction model, *World J Emerg Surg* 2:23, 2007.
  279. **Lipscomb GH, Puckett KJ, Bran D, Ling FW**, Management of separation pain after single-dose methotrexate therapy for ectopic pregnancy, *Obstet Gynecol* 93:590, 1999.
  280. **Stovall TG, Ling FW, Gray LA, Carson SA, Buster JE**, Methotrexate treatment of unruptured ectopic pregnancy: a report of 100 cases, *Obstet Gynecol* 77:749, 1991.
  281. **Lipscomb GH, Givens VM, Meyer NL, Bran D**, Comparison of multidose and single-dose methotrexate protocols for the treatment of ectopic pregnancy, *Am J Obstet Gynecol* 192:1844, 2005.
  282. **Alleyassin A, Khademi A, Aghahosseini M, Safdarian L, Badenoosh B, Hamed EA**, Comparison of success rates in the medical management of ectopic pregnancy with single-dose and multiple-dose administration of methotrexate: a prospective, randomized clinical trial, *Fertil Steril* 85:1661, 2006.

283. **Yang C, Cai J, Geng Y, Gao Y**, Multiple-dose and double-dose versus single-dose administration of methotrexate for the treatment of ectopic pregnancy: a systematic review and meta-analysis, *Reprod Biomed Online* 34(4):383, 2017. doi:10.1016/j.rbmo.2017.01.004.
284. **Song T, Kim MK, Kim ML, Jung YW, Yun BS, Seong SJ**, Single-dose versus two-dose administration of methotrexate for the treatment of ectopic pregnancy: a randomized controlled trial, *Hum Reprod* 31(2):332, 2016. doi:10.1093/humrep/dev312.
285. **Hamed HO, Ahmed SR, Alghasham AA**, Comparison of double- and single-dose methotrexate protocols for treatment of ectopic pregnancy, *Int J Gynaecol Obstet* 116(1):67, 2012.
286. **Yuk JS, Lee JH, Park WI, Ahn HS, Kim HJ**, Systematic review and meta-analysis of single-dose and non-single-dose methotrexate protocols in the treatment of ectopic pregnancy, *Int J Gynaecol Obstet* 141(3):295, 2018. doi:10.1002/ijgo.12473.
287. **Hajenius PJ, Engelsbel S, Mol BW, Van der Veen F, Ankum WM, Bossuyt PM, Hemrika DJ, Lammes FB**, Randomised trial of systemic methotrexate versus laparoscopic salpingostomy in tubal pregnancy, *Lancet* 350:774, 1997.
288. **Sowter MC, Farquhar CM, Petrie KJ, Gudex G**, A randomised trial comparing single dose systemic methotrexate and laparoscopic surgery for the treatment of unruptured tubal pregnancy, *Br J Obstet Gynaecol* 108:192, 2001.
289. **Elito J Jr, Han KK, Camano L**, Values of beta-human chorionic gonadotropin as a risk factor for tubal obstruction after tubal pregnancy, *Acta Obstet Gynecol Scand* 84:864, 2005.
290. **Bernoux A, Job-Spira N, Germain E, Coste J, Bouyer J**, Fertility outcome after ectopic pregnancy and use of an intrauterine device at the time of the index ectopic pregnancy, *Hum Reprod* 15:1173, 2000.
291. **Job-Spira N, Bouyer J, Pouly JL, Germain E, Coste J, Aublet-Cuvelier B, Fernandez H**, Fertility after ectopic pregnancy: first results of a population-based cohort study in France, *Hum Reprod* 11:99, 1996.
292. **al-Nuaim L, Bangboye EA, Chowdhury N, Adelus B**, Reproductive potential after an ectopic pregnancy, *Fertil Steril* 64:942, 1995.
293. **Gruft L, Bertola E, Luchini L, Azzilonna C, Bigatti G, Parazzini F**, Determinants of reproductive prognosis after ectopic pregnancy, *Hum Reprod* 9:1333, 1994.
294. **Pouly JL, Chapron C, Manhes H, Canis M, Wattiez A, Bruhat MA**, Multifactorial analysis of fertility after conservative laparoscopic treatment of ectopic pregnancy in a series of 223 patients, *Fertil Steril* 56:453, 1991.
295. **Sultana CJ, Easley K, Collins RL**, Outcome of laparoscopic versus traditional surgery for ectopic pregnancies, *Fertil Steril* 57:285, 1992.
296. **Ory SJ, Nnadi E, Herrmann R, O'Brien PS, Melton LJ III**, Fertility after ectopic pregnancy, *Fertil Steril* 60:231, 1993.
297. **Ego A, Subtil D, Cosson M, Legoueff F, Houfflin-Debarge V, Querleu D**, Survival analysis of fertility after ectopic pregnancy, *Fertil Steril* 75:560, 2001.
298. **Gervaise A, Masson L, de Tayrac R, Frydman R, Fernandez H**, Reproductive outcome after methotrexate treatment of tubal pregnancies, *Fertil Steril* 82:304, 2004.
299. **Pektasides D, Rustin GJ, Newlands ES, Begent RH, Bagshawe KD**, Fertility after chemotherapy for ovarian germ cell tumours, *Br J Obstet Gynaecol* 94:477, 1987.
300. **Ayhan A, Ergeneli MH, Yuce K, Yapar EG, Kisanisci AH**, Pregnancy after chemotherapy for gestational trophoblastic disease, *J Reprod Med* 35:522, 1990.
301. **Keefe KA, Wald JS, Goldstein DP, Bernstein M, Berkowitz RS**, Reproductive outcome after methotrexate treatment of tubal pregnancies, *J Reprod Med* 43:28, 1998.
302. **Kung FT, Chang SY, Tsai YC, Hwang FR, Hsu TY, Soong YK**, Subsequent reproduction and obstetric outcome after methotrexate treatment of cervical pregnancy: a review of original literature and international collaborative follow-up, *Hum Reprod* 12:591, 1997.
303. **Oriol B, Barrio A, Pacheco A, Serna J, Zuzuarregui JL, Garcia-Velasco JA**, Systemic methotrexate to treat ectopic pregnancy does not affect ovarian reserve, *Fertil Steril* 90:1579, 2008.
304. **Morlock RJ, Lafata JE, Eisenstein D**, Cost-effectiveness of single-dose methotrexate compared with

laparoscopic treatment of ectopic pregnancy, *Obstet Gynecol* 95:407, 2000.

305. **Nieuwkerk PT, Hajenius PJ, Van der Veen F, Ankum WM, Wijker W, Bossuyt PM**, Systemic methotrexate therapy versus laparoscopic salpingostomy in tubal pregnancy. Part II. Patient preferences for systemic methotrexate, *Fertil Steril* 70:518, 1998.
306. **Fernandez H, Yves Vincent SC, Pauthier S, Audibert F, Frydman R**, Randomized trial of conservative laparoscopic treatment and methotrexate administration in ectopic pregnancy and subsequent fertility, *Hum Reprod* 13:3239, 1998.
307. **Nieuwkerk PT, Hajenius PJ, Ankum WM, Van der Veen F, Wijker W, Bossuyt PM**, Systemic methotrexate therapy versus laparoscopic salpingostomy in patients with tubal pregnancy. Part I. Impact on patients' health-related quality of life, *Fertil Steril* 70:511, 1998.
308. **Cohen DR, Falcone T, Khalife S**, Methotrexate: local versus intramuscular, *Fertil Steril* 65:206, 1996.
309. **Schiff E, Shalev E, Bustan M, Tsafari A, Mashiach S, Winer E**, Pharmacokinetics of methotrexate after local tubal injection for conservative treatment of ectopic pregnancy, *Fertil Steril* 57:688, 1992.
310. **Doubilet PM, Benson CB, Frates MC, Ginsburg E**, Sonographically guided minimally invasive treatment of unusual ectopic pregnancies, *J Ultrasound Med* 23:359, 2004.
311. **Brumsted J, Kessler C, Gibson C, Nakajima S, Riddick DH, Gibson M**, A comparison of laparoscopy and laparotomy for the treatment of ectopic pregnancy, *Obstet Gynecol* 71:889, 1988.
312. **Silva PD**, A laparoscopic approach can be applied to most cases of ectopic pregnancy, *Obstet Gynecol* 72:944, 1988.
313. **Vermesh M, Silva PD, Rosen GF, Stein AL, Fossum GT, Sauer MV**, Management of unruptured ectopic gestation by linear salpingostomy: a prospective, randomized clinical trial of laparoscopy versus laparotomy, *Obstet Gynecol* 73:400, 1989.
314. **Lundorff P, Thorburn J, Hahlin M, Kallfelt B, Lindblom B**, Laparoscopic surgery in ectopic pregnancy. A randomized trial versus laparotomy, *Acta Obstet Gynecol Scand* 70:343, 1991.
315. **Lundorff P, Hahlin M, Kallfelt B, Thorburn J, Lindblom B**, Adhesion formation after laparoscopic surgery in tubal pregnancy: a randomized trial versus laparotomy, *Fertil Steril* 55:911, 1991.
316. **Murphy AA, Nager CW, Wujek JJ, Kettel LM, Torp VA, Chin HG**, Operative laparoscopy versus laparotomy for the management of ectopic pregnancy: a prospective trial, *Fertil Steril* 57:1180, 1992.
317. **Gray DT, Thorburn J, Lundorff P, Strandell A, Lindblom B**, A cost-effectiveness study of a randomised trial of laparoscopy versus laparotomy for ectopic pregnancy, *Lancet* 345:1139, 1995.
318. **Lundorff P, Thorburn J, Lindblom B**, Fertility outcome after conservative surgical treatment of ectopic pregnancy evaluated in a randomized trial, *Fertil Steril* 57:998, 1992.
319. **Ugur M, Yesilyurt H, Soysal S, Gokmen O**, Prophylactic vasopressin during laparoscopic salpingotomy for ectopic pregnancy, *J Am Assoc Gynecol Laparosc* 3:365, 1996.
320. **Fedele L, Bianchi S, Tozzi L, Zanconato G, Silvestre V**, Intramesosalpingeal injection of oxytocin in conservative laparoscopic treatment for tubal pregnancy: preliminary results, *Hum Reprod* 13:3042, 1998.
321. **Tulandi T, Guralnick M**, Treatment of tubal ectopic pregnancy by salpingotomy with or without tubal suturing and salpingectomy, *Fertil Steril* 55:53, 1991.
322. **Milad MP, Klein E, Kazer RR**, Preoperative serum hCG level and intraoperative failure of laparoscopic linear salpingostomy for ectopic pregnancy, *Obstet Gynecol* 92:373, 1998.
323. **Cheng X, Tian X, Yan Z, Jia M, Deng J, Wang Y, Fan D**, Comparison of the fertility outcome of salpingotomy and salpingectomy in women with tubal pregnancy: a systematic review and meta-analysis, *PLoS One* 11(3):e0152343, 2016. doi:10.1371/journal.pone.0152343.
324. **Sherman D, Langer R, Herman A, Bukovsky I, Caspi E**, Reproductive outcome after fimbrial evacuation of tubal pregnancy, *Fertil Steril* 47:420, 1987.
325. **Tuomivaara L, Kauppila A**, Radical or conservative surgery for ectopic pregnancy? A follow-up study of fertility of 323 patients, *Fertil Steril* 50:580, 1988.
326. **Bangsgaard N, Lund CO, Ottesen B, Nilas L**, Improved fertility following conservative surgical treatment of ectopic pregnancy, *BJOG* 110:765, 2003.
327. **Seifer DB**, Persistent ectopic pregnancy: an argument for heightened vigilance and patient compliance, *Fertil*

Steril 68:402, 1997.

328. **Kelly RW, Martin SA, Strickler RC**, Delayed hemorrhage in conservative surgery for ectopic pregnancy, *Am J Obstet Gynecol* 133:225, 1979.
329. **Seifer DB, Gutmann JN, Doyle MB, Jones EE, Diamond MP, DeCherney AH**, Persistent ectopic pregnancy following laparoscopic linear salpingostomy, *Obstet Gynecol* 76:1121, 1990.
330. **Seifer DB, Diamond MP, DeCherney AH**, Persistent ectopic pregnancy, *Obstet Gynecol Clin North Am* 18:153, 1991.
331. **Seifer DB, Gutmann JN, Grant WD, Kamps CA, DeCherney AH**, Comparison of persistent ectopic pregnancy after laparoscopic salpingostomy versus salpingostomy at laparotomy for ectopic pregnancy, *Obstet Gynecol* 81:378, 1993.
332. **Hajenius PJ, Mol BW, Ankum WM, van der Veen F, Bossuyt PM, Lammes FB**, Clearance curves of serum human chorionic gonadotrophin for the diagnosis of persistent trophoblast, *Hum Reprod* 10:683, 1995.
333. **DiMarchi JM, Kosasa TS, Kobara TY, Hale RW**, Persistent ectopic pregnancy, *Obstet Gynecol* 70:555, 1987.
334. **Nathorst-Boos J, Rafik Hamad R**, Risk factors for persistent trophoblastic activity after surgery for ectopic pregnancy, *Acta Obstet Gynecol Scand* 83:471, 2004.
335. **Goldstein JS, Ratts VS, Philpott T, Dahan MH**, Risk of surgery after use of potassium chloride for treatment of tubal heterotopic pregnancy, *Obstet Gynecol* 107:506, 2006.
336. **Graczykowski JW, Mishell DR Jr**, Methotrexate prophylaxis for persistent ectopic pregnancy after conservative treatment by salpingostomy, *Obstet Gynecol* 89:118, 1997.
337. **Spandorfer SD, Sawin SW, Benjamin I, Barnhart KT**, Postoperative day 1 serum human chorionic gonadotropin level as a predictor of persistent ectopic pregnancy after conservative surgical management, *Fertil Steril* 68:430, 1997.
338. **Hoppe DE, Bekkar BE, Nager CW**, Single-dose systemic methotrexate for the treatment of persistent ectopic pregnancy after conservative surgery, *Obstet Gynecol* 83:51, 1994.
339. **Gracia CR, Brown HA, Barnhart KT**, Prophylactic methotrexate after linear salpingostomy: a decision analysis, *Fertil Steril* 76:1191, 2001.
340. **Seifer DB, Silva PD, Grainger DA, Barber SR, Grant WD, Gutmann JN**, Reproductive potential after treatment for persistent ectopic pregnancy, *Fertil Steril* 62:194, 1994.
341. **Pisarska MD, Casson PR, Moise KJ Jr, DiMaio DJ, Buster JE, Carson SA**, Heterotopic abdominal pregnancy treated at laparoscopy, *Fertil Steril* 70:159, 1998.
342. **Barrenetxea G, Barinaga-Rementería L, Lopez de Larruzea A, Agirregoikoa JA, Mandiola M, Carbonero K**, Heterotopic pregnancy: two cases and a comparative review, *Fertil Steril* 87:417 e9, 2007.
343. **Habana A, Dokras A, Giraldo JL, Jones EE**, Cornual heterotopic pregnancy: contemporary management options, *Am J Obstet Gynecol* 182:1264, 2000.
344. **Hsieh BC, Hwang JL, Pan HS, Huang SC, Chen CY, Chen PH**, Heterotopic Cesarean scar pregnancy combined with intrauterine pregnancy successfully treated with embryo aspiration for selective embryo reduction: case report, *Hum Reprod* 19:285, 2004.
345. **Shojai R, Chaumoitre K, Chau C, Panuel M, Boubli L, d'Ercole C**, Advanced combined abdominal and intrauterine pregnancy: a case report, *Fetal Diagn Ther* 22:128, 2007.
346. **Hassiakos D, Bakas P, Pistofidis G, Creatsas G**, Heterotopic pregnancy at 16 weeks of gestation after in-vitro fertilization and embryo transfer, *Arch Gynecol Obstet* 266:124, 2002.
347. **Tal J, Haddad S, Gordon N, Timor-Tritsch I**, Heterotopic pregnancy after ovulation induction and assisted reproductive technologies: a literature review from 1971 to 1993, *Fertil Steril* 66:1, 1996.
348. **Cheng PJ, Chueh HY, Qiu JT**, Heterotopic pregnancy in a natural conception cycle presenting as hematometra, *Obstet Gynecol* 104:1195, 2004.
349. **Clayton HB, Schieve LA, Peterson HB, Jamieson DJ, Reynolds MA, Wright VC**, A comparison of heterotopic and intrauterine-only pregnancy outcomes after assisted reproductive technologies in the United States from 1999 to 2002, *Fertil Steril* 87:303, 2007.
350. **Oyawoye S, Chander B, Pavlovic B, Hunter J, Gadir AA**, Heterotopic pregnancy: successful management

with aspiration of cornual/interstitial gestational sac and instillation of small dose of methotrexate, *Fetal Diagn Ther* 18:1, 2003.

351. **Salomon LJ, Fernandez H, Chauveaud A, Doumerc S, Frydman R**, Successful management of a heterotopic Caesarean scar pregnancy: potassium chloride injection with preservation of the intrauterine gestation: case report, *Hum Reprod* 18:189, 2003.
352. **Strohmer H, Obruca A, Lehner R, Egarter C, Husslein P, Feichtinger W**, Successful treatment of a heterotopic pregnancy by sonographically guided instillation of hyperosmolar glucose, *Fertil Steril* 69:149, 1998.
353. **Goldberg JM, Bedaiwy MA**, Transvaginal local injection of hyperosmolar glucose for the treatment of heterotopic pregnancies, *Obstet Gynecol* 107:509, 2006.
354. **Funamizu A, Fukui A, Fukuhara R, Kobayashi A, Chiba H, Matsumura Y, Ito A, Mizunuma H**, A case of bilateral tubal pregnancy, *Gynecol Minim Invasive Ther* 6(4):191, 2017. doi:10.1016/j.gmit.2017.05.003.
355. **Sugawara N, Sato R, Kato M, Manome T, Kimura Y, Araki Y, Araki Y**, Bilateral tubal pregnancies after a single-embryo transfer, *Reprod Med Biol* 16(4):396, 2017. doi:10.1002/rmb2.12053.
356. **Xu H**, A spontaneous bilateral tubal pregnancy: a case report, *Medicine (Baltimore)* 97(38):e12365, 2018.
357. **Atrash HK, Friede A, Hogue CJ**, Abdominal pregnancy in the United States: frequency and maternal mortality, *Obstet Gynecol* 69:333, 1987.
358. **Fisch B, Peled Y, Kaplan B, Zehavi S, Neri A**, Abdominal pregnancy following in vitro fertilization in a patient with previous bilateral salpingectomy, *Obstet Gynecol* 88:642, 1996.
359. **Rahman MS, Al-Suleiman SA, Rahman J, Al-Sibai MH**, Advanced abdominal pregnancy—observations in 10 cases, *Obstet Gynecol* 59:366, 1982.
360. **Lamina MA, Akinyemi BO, Fakoya TA, Shorunmu TO, Oladapo OT**, Abdominal pregnancy: a cause of failed induction of labour, *Niger J Med* 14:213, 2005.
361. **Varma R, Mascarenhas L, James D**, Successful outcome of advanced abdominal pregnancy with exclusive omental insertion, *Ultrasound Obstet Gynecol* 21:192, 2003.
362. **Morita Y, Tsutsumi O, Kuramochi K, Momoeda M, Yoshikawa H, Taketani Y**, Successful laparoscopic management of primary abdominal pregnancy, *Hum Reprod* 11:2546, 1996.
363. **Gerli S, Rossetti D, Baiocchi G, Clerici G, Unfer V, Di Renzo GC**, Early ultrasonographic diagnosis and laparoscopic treatment of abdominal pregnancy, *Eur J Obstet Gynecol Reprod Biol* 113:103, 2004.
364. **Zinger M, Rosenfeld D**, Failed treatment of abdominal pregnancy with methotrexate. A case report, *J Reprod Med* 46:392, 2001.
365. **Beddock R, Naepels P, Gondry C, Besserve P, Camier B, Boulanger JC, Gondry J**, [Diagnosis and current concepts of management of advanced abdominal pregnancy], *Gynecol Obstet Fertil* 32:55, 2004.
366. **Martin JN Jr, Sessums JK, Martin RW, Pryor JA, Morrison JC**, Abdominal pregnancy: current concepts of management, *Obstet Gynecol* 71:549, 1988.
367. **Oki T, Baba Y, Yoshinaga M, Douchi T**, Super-selective arterial embolization for uncontrolled bleeding in abdominal pregnancy, *Obstet Gynecol* 112:427, 2008.
368. **Rahaman J, Berkowitz R, Mitty H, Gaddipati S, Brown B, Nezhad F**, Minimally invasive management of an advanced abdominal pregnancy, *Obstet Gynecol* 103:1064, 2004.
369. **Cardosi RJ, Nackley AC, Londono J, Hoffman MS**, Embolization for advanced abdominal pregnancy with a retained placenta. A case report, *J Reprod Med* 47:861, 2002.
370. **Hallatt JG**, Primary ovarian pregnancy: a report of twenty-five cases, *Am J Obstet Gynecol* 143:55, 1982.
371. **Grimes HG, Nosal RA, Gallagher JC**, Ovarian pregnancy: a series of 24 cases, *Obstet Gynecol* 61:174, 1983.
372. **Sinha P, Wissa IM**, Ovarian pregnancy simulating a haemorrhagic corpus luteum, *J Obstet Gynaecol* 24:197, 2004.
373. **Adeniran A, Stanek J**, Ovarian pregnancy, *Arch Pathol Lab Med* 127:1635, 2003.
374. **Shamma FN, Schwartz LB**, Primary ovarian pregnancy successfully treated with methotrexate, *Am J Obstet Gynecol* 167:1307, 1992.
375. **Raziel A, Golan A**, Primary ovarian pregnancy successfully treated with methotrexate, *Am J Obstet Gynecol* 169:1362, 1993.

376. **Habbu J, Read MD**, Ovarian pregnancy successfully treated with methotrexate, *J Obstet Gynaecol* 26:587, 2006.
377. **Tulandi T, Al-Jaroudi D**, Interstitial pregnancy: results generated from the Society of Reproductive Surgeons Registry, *Obstet Gynecol* 103:47, 2004.
378. **Ackerman TE, Levi CS, Dashefsky SM, Holt SC, Lindsay DJ**, Interstitial line: sonographic finding in interstitial (cornual) ectopic pregnancy, *Radiology* 189:83, 1993.
379. **Timor-Tritsch IE, Monteagudo A, Matera C, Veit CR**, Sonographic evolution of cornual pregnancies treated without surgery, *Obstet Gynecol* 79:1044, 1992.
380. **Jansen RP, Elliott PM**, Angular intrauterine pregnancy, *Obstet Gynecol* 58:167, 1981.
381. **Lau S, Tulandi T**, Conservative medical and surgical management of interstitial ectopic pregnancy, *Fertil Steril* 72:207, 1999.
382. **Moon HS, Choi YJ, Park YH, Kim SG**, New simple endoscopic operations for interstitial pregnancies, *Am J Obstet Gynecol* 182:114, 2000.
383. **Moawad NS, Mahajan ST, Moniz MH, Taylor SE, Hurd WW**, Current diagnosis and treatment of interstitial pregnancy, *Am J Obstet Gynecol* 202:15, 2010.
384. **Jermy K, Thomas J, Doo A, Bourne T**, The conservative management of interstitial pregnancy, *Br J Obstet Gynaecol* 111:1283, 2004.
385. **Meyer WR, Mitchell DE**, Hysteroscopic removal of an interstitial ectopic gestation. A case report, *J Reprod Med* 34:928, 1989.
386. **Budnick SG, Jacobs SL, Nulsen JC, Metzger DA**, Conservative management of interstitial pregnancy, *Obstet Gynecol Surv* 48:694, 1993.
387. **Deruelle P, Lucot JP, Lions C, Robert Y**, Management of interstitial pregnancy using selective uterine artery embolization, *Obstet Gynecol* 106:1165, 2005.
388. **Ophir E, Singer-Jordan J, Oettinger M, Odeh M, Tendler R, Feldman Y, Fait V, Bornstein J**, Uterine artery embolization for management of interstitial twin ectopic pregnancy: case report, *Hum Reprod* 19:1774, 2004.
389. **Benifla JL, Fernandez H, Sebban E, Darai E, Frydman R, Madelenat P**, Alternative to surgery of treatment of unruptured interstitial pregnancy: 15 cases of medical treatment, *Eur J Obstet Gynecol Reprod Biol* 70:151, 1996.
390. **Weissman A, Fishman A**, Uterine rupture following conservative surgery for interstitial pregnancy, *Eur J Obstet Gynecol Reprod Biol* 44:237, 1992.
391. **Downey GP, Tuck SM**, Spontaneous uterine rupture during subsequent pregnancy following non-excision of an interstitial ectopic gestation, *Br J Obstet Gynaecol* 101:162, 1994.
392. **Ushakov FB, Elchalal U, Aceman PJ, Schenker JG**, Cervical pregnancy: past and future, *Obstet Gynecol Surv* 52:45, 1997.
393. **Vela G, Tulandi T**, Cervical pregnancy: the importance of early diagnosis and treatment, *J Minim Invasive Gynecol* 14:481, 2007.
394. **Karande VC, Flood JT, Heard N, Veeck L, Muasher SJ**, Analysis of ectopic pregnancies resulting from in-vitro fertilization and embryo transfer, *Hum Reprod* 6:446, 1991.
395. **Hofmann HM, Urdl W, Hofler H, Honigl W, Tamussino K**, Cervical pregnancy: case reports and current concepts in diagnosis and treatment, *Arch Gynecol Obstet* 241:63, 1987.
396. **Kung FT, Lin H, Hsu TY, Chang CY, Huang HW, Huang LY, Chou YJ, Huang KH**, Differential diagnosis of suspected cervical pregnancy and conservative treatment with the combination of laparoscopy-assisted uterine artery ligation and hysteroscopic endocervical resection, *Fertil Steril* 81:1642, 2004.
397. **Jurkovic D, Hacket E, Campbell S**, Diagnosis and treatment of early cervical pregnancy: a review and a report of two cases treated conservatively, *Ultrasound Obstet Gynecol* 8:373, 1996.
398. **Monteagudo A, Tarricone NJ, Timor-Tritsch IE, Lerner JP**, Successful transvaginal ultrasound-guided puncture and injection of a cervical pregnancy in a patient with simultaneous intrauterine pregnancy and a history of a previous cervical pregnancy, *Ultrasound Obstet Gynecol* 8:381, 1996.
399. **Cepni I, Ocal P, Erkan S, Erzik B**, Conservative treatment of cervical ectopic pregnancy with transvaginal

- ultrasound-guided aspiration and single-dose methotrexate, *Fertil Steril* 81:1130, 2004.
400. **Mesogitis S, Pilalis A, Daskalakis G, Papantoniou N, Antsaklis A**, Management of early viable cervical pregnancy, *Br J Obstet Gynaecol* 112:409, 2005.
  401. **Kirk E, Condous G, Haider Z, Syed A, Ojha K, Bourne T**, The conservative management of cervical ectopic pregnancies, *Ultrasound Obstet Gynecol* 27:430, 2006.
  402. **Jeng CJ, Ko ML, Shen J**, Transvaginal ultrasound-guided treatment of cervical pregnancy, *Obstet Gynecol* 109:1076, 2007.
  403. **Frates MC, Benson CB, Doubilet PM, Di Salvo DN, Brown DL, Laing FC, Rein MS, Osathanondh R**, Cervical ectopic pregnancy: results of conservative treatment, *Radiology* 191:773, 1994.
  404. **Suzumori N, Katano K, Sato T, Okada J, Nakanishi T, Muto D, Suzuki Y, Ikuta K, Suzumori K**, Conservative treatment by angiographic artery embolization of an 11-week cervical pregnancy after a period of heavy bleeding, *Fertil Steril* 80:617, 2003.
  405. **Hajenius PJ, Roos D, Ankum WM, Van der Veen F**, Are serum human chorionic gonadotropin clearance curves of use in monitoring methotrexate treatment in cervical pregnancy?, *Fertil Steril* 70:362, 1998.
  406. **Lee CL, Wang CJ, Chao A, Yen CF, Soong YK**, Laparoscopic management of an ectopic pregnancy in a previous Caesarean section scar, *Hum Reprod* 14:1234, 1999.
  407. **Rotas MA, Haberman S, Levгур M**, Cesarean scar ectopic pregnancies: etiology, diagnosis, and management, *Obstet Gynecol* 107:1373, 2006.
  408. **Valley MT, Pierce JG, Daniel TB, Kaunitz AM**, Cesarean scar pregnancy: imaging and treatment with conservative surgery, *Obstet Gynecol* 91:838, 1998.
  409. **Fylstra DL**, Ectopic pregnancy within a cesarean scar: a review, *Obstet Gynecol Surv* 57(8):537, 2002.
  410. **Timor-Tritsch IE, Monteagudo A**, Unforeseen consequences of the increasing rate of cesarean deliveries: early placenta accreta and cesarean scar pregnancy. A review, *Am J Obstet Gynecol* 207(1):14, 2012. doi:10.1016/j.ajog.2012.03.007. Erratum in: *Am J Obstet Gynecol* 210(4):371, 2014.
  411. **Ash A, Smith A, Maxwell D**, Cesarean scar pregnancy, *Br J Obstet Gynaecol* 114:253, 2007.
  412. **Osborn DA, Williams TR, Craig BM**, Cesarean scar pregnancy: sonographic and magnetic resonance imaging findings, complications, and treatment, *J Ultrasound Med* 31(9):1449, 2012.
  413. **Maymon R, Svirsky R, Smorgick N, Mendlovic S, Halperin R, Gilad K, Tovbin J**, Fertility performance and obstetric outcomes among women with previous cesarean scar pregnancy, *J Ultrasound Med* 30(9):1179, 2011.
  414. **Ouyang Y, Li X, Yi Y, Gong F, Lin G, Lu G**, First-trimester diagnosis and management of cesarean scar pregnancies after in vitro fertilization-embryo transfer: a retrospective clinical analysis of 12 cases, *Reprod Biol Endocrinol* 13: 126, 2015.
  415. **Graesslin O, Dedecker F Jr, Quereux C, Gabriel R**, Conservative treatment of ectopic pregnancy in a cesarean scar, *Obstet Gynecol* 105:869, 2005.
  416. **Armstrong V, Hansen WF, Van Voorhis BJ, Syrop CH**, Detection of cesarean scars by transvaginal ultrasound, *Obstet Gynecol* 101:61, 2003.
  417. **Oflin-Yebovi D, Ben-Nagi J, Sawyer E, Yazbek J, Lee C, Gonzalez J, Jurkovic D**, Deficient lower-segment Cesarean section scars: prevalence and risk factors, *Ultrasound Obstet Gynecol* 31:72, 2008.
  418. **Calì G, Timor-Tritsch IE, Palacios-Jaraquemada J, Monteagudo A, Buca D, Forlani F, Familiari A, Scambia G, Acharya G, D'Antonio F**, Outcome of cesarean scar pregnancy managed expectantly: systematic review and meta-analysis, *Ultrasound Obstet Gynecol* 51(2):169, 2018. doi:10.1002/uog.17568.
  419. **Birch Petersen K, Hoffmann E, Rifbjerg Larsen C, Svarre Nielsen H**, Cesarean scar pregnancy: a systematic review of treatment studies, *Fertil Steril* 105(4):958, 2016. doi:10.1016/j.fertnstert.2015.12.130.
  420. **Jurkovic D, Hillaby K, Woelfer B, Lawrence A, Salim R, Elson CJ**, First-trimester diagnosis and management of pregnancies implanted into the lower uterine segment Cesarean section scar, *Ultrasound Obstet Gynecol* 21:220, 2003.
  421. **Sugawara J, Senoo M, Chisaka H, Yaegashi N, Okamura K**, Successful conservative treatment of a cesarean scar pregnancy with uterine artery embolization, *Tohoku J Exp Med* 206:261, 2005.
  422. **Yang MJ, Jeng MH**, Combination of transarterial embolization of uterine arteries and conservative surgical



treatment for pregnancy in a cesarean section scar. A report of 3 cases, *J Reprod Med* 48:213, 2003.

423. **Chou MM, Hwang JI, Tseng JJ, Huang YF, Ho ES**, Cesarean scar pregnancy: quantitative assessment of uterine neovascularization with 3-dimensional color power Doppler imaging and successful treatment with uterine artery embolization, *Am J Obstet Gynecol* 190:866, 2004.
424. **Zhuang Y, Huang L**, Uterine artery embolization compared with methotrexate for the management of pregnancy implanted within a cesarean scar, *Am J Obstet Gynecol* 201:152 e1, 2009.
425. **Timor-Tritsch IE, Monteagudo A, Bennett TA, Foley C, Ramos J, Kaelin Agten A**, A new minimally invasive treatment for cesarean scar pregnancy and cervical pregnancy, *Am J Obstet Gynecol* 215(3):351.e1, 2016. doi:10.1016/j.ajog.2016.03.010.
426. **Timor-Tritsch IE, Monteagudo A, Kaelin Agten A**, Recap—minimally invasive treatment for cesarean scar pregnancy using a double-balloon catheter: additional suggestions to the technique, *Am J Obstet Gynecol* 217(4):496, 2017.
427. **Zosmer N, Fuller J, Shaikh H, Johns J, Ross JA**, Natural history of early first-trimester pregnancies implanted in cesarean scars, *Ultrasound Obstet Gynecol* 46(3):367, 2015. doi:10.1002/uog.14775.
428. **Timor-Tritsch IE, Monteagudo A, Cali G, Vintzileos A, Viscarello R, Al-Khan A, Zamudio S, Mayberry P, Cordoba MM, Dar P**, Cesarean scar pregnancy is a precursor of morbidly adherent placenta, *Ultrasound Obstet Gynecol* 44(3):346, 2014. doi:10.1002/uog.13426.
429. **Seow KM, Huang LW, Lin YH, Lin MY, Tsai YL, Hwang JL**, Cesarean scar pregnancy: issues in management, *Ultrasound Obstet Gynecol* 23:247, 2004.
430. **Seow KM, Hwang JL, Tsai YL, Huang LW, Lin YH, Hsieh BC**, Subsequent pregnancy outcome after conservative treatment of a previous cesarean scar pregnancy, *Acta Obstet Gynecol Scand* 83:1167, 2004.
431. **Ben Nagi J, Helmy S, Ofili-Yebovi D, Yazbek J, Sawyer E, Jurkovic D**, Reproductive outcomes of women with a previous history of Caesarean scar ectopic pregnancies, *Hum Reprod* 22:2012, 2007.
432. **Gao L, Huang Z, Zhang X, Zhou N, Huang X, Wang X**, Reproductive outcomes following cesarean scar pregnancy—a case series and review of the literature, *Eur J Obstet Gynecol Reprod Biol* 200:102, 2016. doi:10.1016/j.ejogrb.2016.02.039.
433. **Wang Q, Peng HL, He L, Zhao X**, Reproductive outcomes after previous cesarean scar pregnancy: follow up of 189 women, *Taiwan J Obstet Gynecol* 54(5):551, 2015.
434. **Rosen T**, Placenta accreta and cesarean scar pregnancy: overlooked costs of the rising cesarean section rate, *Clin Perinatol* 35:519, 2008.

# Appendix: Selected Laboratory Values Expressed in Conventional Units and the International System of Units (SI Units)

## Laboratory Values for Selected Measurements in Urine

Substance	Conventional Units	Conversion Factor	SI Units
Cortisol, free	10–90 µg/24 h	2.759	28–250 nmol/24 h
Estrogens, total	5–25 µg/24 h	3.67	18–92 nmol/24 h
17-Hydroxycorticosteroids	2–6 mg/24 h	2.759	5.5–15.5 mmol/24 h
17-Ketosteroids	6.0–15 mEq/24 h	3.467	21–52.5 mmol/24 h

## SI Prefixes and Their Symbols

$10^9$	giga	G
$10^6$	mega	M
$10^3$	kilo	k
$10^2$	hecto	h
$10^1$	deka	da
$10^{-1}$	deci	d
$10^{-2}$	centi	c
$10^{-3}$	milli	m
$10^{-6}$	micro	$\mu$
$10^{-9}$	nano	n
$10^{-12}$	pico	p
$10^{-15}$	femto	f
$10^{-18}$	atto	a

**Laboratory Values for Selected Measurements in Blood, Plasma, and Serum**

Substance	Conventional Units	Conversion Factor	SI Units
ACTH, adrenocorticotropin hormone 6:00 A.M. 6:00 P.M.	10–80 pg/mL <50 pg/mL	0.2202 0.2202	2.2–17.6 pmol/L <11 pmol/L
Alkaline phosphatase, bone specific Premenopausal Postmenopausal	µg/L 5.0–19 5.6–29	1.0	µg/L 5–19 5.6–29
Antimüllerian hormone (AMH) <3 mo 3 mo to 2 y 2–12 y 13–45 y >45 y Postmenopausal	ng/mL Undetectable <5 <10 1–10 <1 Undetectable	7.1429	pmol/L Undetectable <35 <70 7–70 <10 Undetectable
Androstenedione	60–300 ng/dL	0.0349	2.1–10.5 nmol/L
Calcium, total	8.5–10.5 mg/dL	0.25	2.1–2.6 mmol/L
Cholesterol LDL cholesterol HDL cholesterol Total cholesterol	<200 mg/dL 60–130 mg/dL >50 mg/dL	0.0259 0.0259 0.0259	<5.2 mmol/L 1.6–3.4 mmol/L >1.3 mmol/L
Collagen type I C-telopeptide (CTX) Premenarchal 18–29 y 30–39 y 40–49 y ≥50 y	pg/mL Not established 64–640 60–650 40–465 Not established	1.0	ng/L Not established 64–640 60–650 40–465 Not established
Cortisol 8:00 A.M. 4:00 P.M. 10:00 P.M.	5–25 µg/dL 3–12 µg/dL <50% of A.M. value	27.6 27.6 27.6	140–690 nmol/L 80–330 nmol/L <50% of A.M. value
DHEA-S, dehydroepiandrosterone sulfate	80–350 µg/dL	0.0027	2.2–9.5 µmol/L
11-Deoxycortisol	0.05–0.25 µg/dL	28.86	1.5–7.3 nmol/L
11-Deoxycorticosterone	2–10 ng/dL	30.3	60–300 pmol/L
Estradiol	20–400 pg/mL	3.67	70–1,500 pmol/L
Estrone	30–200 pg/mL	3.7	110–740 pmol/L
FSH, reproductive years	5–20 mIU/mL	1.0	5–20 IU/L
Glucose, fasting	70–110 mg/dL	0.0556	4.0–6.0 mmol/L
Growth hormone	<10 ng/mL	1.0	<10 µg/L
17-Hydroxyprogesterone	100–300 ng/dL	0.03	3–9 nmol/L
Inhibin B Premenopausal Follicular Luteal Postmenopausal	pg/mL <139 <92 pg/mL <10	1.0	ng/L <139 <92 pg/mL <10
Insulin, fasting	5–20 µU/mL	7.175	35–145 pmol/L
Insulin-like growth factor-I	0.3–2.2 U/mL	1,000	300–2,200 U/L
LH, reproductive years	5–20 mIU/mL	1.0	5–20 IU/L

Substance	Conventional Units	Conversion Factor	SI Units
Procollagen type I intact N-terminal propeptide Premenopausal Postmenopausal	µg/L 19–83 16–96	0.0286	nmol/L 0.54–2.4 0.45–2.7
Progesterone Follicular phase Secretory phase	<3 ng/mL 5–30 ng/mL	3.18 3.18	<9.5 nmol/L 16–95 nmol/L
Prolactin	1–20 ng/mL	44.4	44.4–888 pmol/L
Testosterone, total	20–80 ng/dL	0.0347	0.7–2.8 nmol/L
Testosterone, free	100–200 pg/dL	0.0347	35–700 pmol/L
TSH, thyroid-stimulating hormone	0.4–4.5 µU/mL	1.0	0.4–4.5 mU/L
Thyroxine, free T <sub>4</sub>	0.8–2.3 ng/dL	1.29	10–30 nmol/L
Triglycerides	<150 mg/dL	0.0113	<1.7 mmol/L
Triiodothyronine, T <sub>3</sub> , total	80–220 ng/dL	0.0154	1.2–3.4 nmol/L
Triiodothyronine, T <sub>3</sub> , free	0.13–0.55 ng/dL	15.4	2.0–8.5 pmol/L
Triiodothyronine, reverse	8–35 ng/dL	15.4	120–540 pmol/L
Vitamin D, 25 hydroxy	ng/mL ≥30 <sup>a</sup> ≥20 <sup>b</sup>	2.496	nmol/L ≥75 ≥50

<sup>a</sup>Endocrine Society threshold for normal.

<sup>b</sup>Institute of Medicine (IOM) threshold for normal.

---

# Index

## A

A/B region

Abdominal pregnancy

Abnormal uterine bleeding (AUB)

- abnormal vessels and

- adenomyosis

- anovulatory bleeding

  - curettage

  - estrogen therapy

  - estrogen-progestin therapy

  - pathophysiology

  - progestin therapy

  - treatment of

- bleeding disorders

- chronic endometritis

- coagulation disorders

- coagulopathy

- danazol and

- diagnostic evaluation of

  - endometrial sampling

  - imaging

  - laboratory evaluation

  - office aspiration biopsy

- differential diagnosis

  - coagulopathy and

  - nonstructural causes

  - structural causes

- endometrial ablation

- endometrial causes

- endometrial hyperplasia

- endometrial polyps

endometrial responses, steroid hormones  
endometrial thickness and  
estrogen breakthrough bleeding  
estrogen withdrawal bleeding  
estrogen-progestin contraceptives  
gonadotropin-releasing hormone agonist, treatment  
gonadotropin-releasing hormone antagonist  
hysteroscopy  
iatrogenic  
levonorgestrel-releasing intrauterine system  
malignancy  
management  
myomas  
neoplasia and  
nonsteroidal anti-inflammatory drugs  
oral contraceptives and  
ovulatory dysfunction  
progestogen breakthrough bleeding  
progestogen withdrawal bleeding  
selective progesterone receptor modulators  
sonohysterography  
summary of clinical principles  
tranexamic acid  
ultrasound  
uterine imaging  
uterine leiomyomas

Abnormalities of semen quality

Abortion

bleeding  
cervical stenosis  
complications of  
counseling  
death from  
dysfunctional uterine bleeding  
ectopic pregnancy and  
first-trimester  
induced

infection  
methotrexate  
mifepristone (RU 486)  
number of  
post abortion contraception  
preoperative care  
prostaglandin  
psychological sequelae of  
safety of  
second-trimester  
sensitization of Rh-negative  
spontaneous. See Early pregnancy loss  
tamoxifen and misoprostol

Acanthosis nigricans

polycystic ovary and

Acetaminophen

17-Acetoxy progesterone

Acne

implant systems of contraception and  
oral contraception

Acromegaly

Acrosin

Acrosome reaction

ACTH-dependent cushing syndrome

ACTH-independent cushing syndrome

Activation function (AF)

Activin(s)

Activin-A

forms of

transforming growth factor- $\beta$  family

Adaptor proteins

Adenomas

nonfunctioning (null)

pituitary prolactin-secreting

bromocriptine, vaginal administration

cabergoline, treatment

dopamine agonist treatment



- pergolide, treatment
- regression with bromocriptine
- results of treatment
- treatment methods
- treatment side-effects

- prolactin adenomas
  - dopamine agonist treatment
  - pregnancy and
    - surveillance during pregnancy
- prolactin-secreting, oral contraception

Adenomyosis

Adenylate cyclase

Adhesion, of blastocyst

Adipose tissue. See also Obesity

- physiology

Adrenal androgen production

Adrenal cortical disorders

Adrenal disorders

- fertility and pregnancy, CAH-affected child
- fetal risks and risk reduction
- history and physical examination
- infertility
- laboratory evaluation
- management of
- women evaluation

Adrenal gland

- anovulation and

- antibodies

- enzyme defects

  - 11 $\beta$ -hydroxylase (P450c11) deficiency

  - 3 $\beta$ -hydroxysteroid dehydrogenase deficiency

  - 21-hydroxylase (P450c21) deficiency

  - nonclassical, hirsutism and

- insufficiency

- oral contraception

Adrenal gland steroidogenesis

Adrenal hyperplasia

congenital (adrenogenital syndrome)

11 $\beta$ -hydroxylase (P450c11) deficiency

3 $\beta$ -hydroxysteroid dehydrogenase deficiency

21-hydroxylase (P450c21) deficiency

treatment

congenital lipoid

nonclassical

Adrenal steroids, breast cancer and

Adrenals

anatomy

androgen-secreting neoplasms

axillary and pubic hair

function

hypothalamo-pituitary-adrenal axis

menstrual abnormalities

physical and sexual maturity

steroidogenic hormone pathway

Adrenarche

mean age of

premature

Adrenocorticotrophic hormone (ACTH)

secretion

Adrenogenital syndrome. See Congenital adrenal hyperplasia

AF-2

Age(ing)

embryo and mature oocyte cryopreservation  
and fertility

adverse effect of

aging follicle and oocyte

endocrinology of reproductive aging

follicular depletion

genetics of

genetics of reproductive aging

inhibin B levels

male

mechanisms of age-related decrease in fertility

number of remaining follicles

physiology of reproductive aging  
rise in circulating FSH concentrations  
uterus

and male fertility

paternal age and pregnancy outcomes

Agouti-related peptide (Agrp)

Alcohol consumption

early pregnancy loss

osteoporosis

Alendronate (Fosamax)

compliance with

effect on fracture risk

Alloimmune disorders

early pregnancy loss

intravenous immunoglobulins

maternal blocking antibody theory

paternal leukocyte immunization

Alopecia

a-fetoprotein (AFP)

Alternative splicing

Alzheimer's disease

ginkgo biloba

Ambiguous genitalia

clinical management, children

family counseling

gender decisions

long-term care

stabilization

diagnostic evaluation

history and physical examination

imaging

initial laboratory evaluation

differential diagnosis

mixed sex chromosome pattern

XX virilization

XY undervirilization

Amenorrhea

acromegaly and  
alkylating agents and  
androgen insensitivity syndrome  
anosmia and  
Asherman's syndrome  
athletes and  
    negative energy balance  
autoimmune disease and  
cervical stenosis  
common causes  
congenital GnRH deficiency  
    GnRH receptor mutations  
    Kallmann's syndrome  
corticotropin-releasing hormone  
critical weight hypothesis  
Cushing's disease  
definition of  
diagnostic considerations  
eating disorders  
effect of radiation and chemotherapy  
    cryopreservation of oocytes  
elevated prolactin levels and  
evaluation of  
    abnormal genital anatomy  
    hypothalamic function  
    imaging  
    medical history  
    normal genital anatomy  
    ovarian function  
    physical examination  
    pituitary function  
exercise and  
family planning decisions and  
functional, genetic and structural causes  
gonadotropins, high levels  
    accompanied by ovaries that contain follicles  
    single gonadotropin deficiency

headaches and  
hypogonadotropic molecular explanations for  
hypothalamic amenorrhea  
hypothyroidism and  
imperforate hymen  
inherited genetic defects  
intrauterine adhesions  
Kallmann's syndrome  
Mayer-Rokitansky-Küster-Hauser syndrome  
microadenomas  
Müllerian agenesis  
oral contraception  
outflow tract problems  
ovary disorders  
pituitary incidentaloma and  
postpill  
progesterin challenge test  
prolactin and  
sella turcica, imaging of  
    elevated prolactin level  
    galactorrhea and  
therapy of anovulatory women  
transverse vaginal septum/cervical atresia  
weight loss, anorexia  
X and Y chromosome deletions

AMH. See Anti-müllerian hormone

Amniotic fluid  
    estriol  
    prolactin in

Anagen

Anaphase

Androgen(s)  
    metabolism  
    polycystic ovary and  
    receptor  
    rise in, peripheral plasma at midcycle  
    synthesis disorders

17 $\alpha$ -hydroxylase deficiency  
3 $\beta$ -hydroxysteroid dehydrogenase deficiency  
17 $\beta$ -hydroxysteroid dehydrogenase deficiency  
P450 oxidoreductase deficiency  
steroid acute regulatory protein deficiency  
steroid 5 $\alpha$ -reductase deficiency

in women

adrenal and ovarian contributions  
androstenedione production  
bioavailability of  
hair and  
testosterone production  
tumor evaluation

Androgen binding protein (ABP)

Androgen excess

fetal origin (congenital adrenal hyperplasia)  
11 $\beta$ -hydroxylase (P450c11) deficiency  
3 $\beta$ -hydroxysteroid dehydrogenase deficiency  
21-hydroxylase (P450c21) deficiency

fetoplacental origin

aromatase (P450arom) deficiency  
P450 oxidoreductase deficiency

maternal origin (gestational hyperandrogenism)

drug ingestion  
pregnancy luteoma  
theca-lutein cysts

polycystic ovary syndrome

Cushing syndrome  
hyperprolactinemia  
idiopathic hirsutism  
insulin resistance syndromes  
ovarian and adrenal tumors  
thyroid disorders

Androgen Excess and PCOS Society (AE-PCOS)

Androgen insensitivity syndromes (AIS)

complete  
delayed puberty

- incomplete syndromes
- Androgen therapy
- Androgenetic alopecia
- Androgen-producing adrenal tumor
  - adrenal CT imaging
  - hormones
- Androgen-secreting neoplasms
  - adrenals
  - of the ovary/adrenal
- Androstane nucleus
- 3 $\alpha$ -Androstanediol glucuronide (AG)
- Androstenedione
  - conversion to estrogen
- Aneuploidy
- Angiogenesis
  - angiopoietins and
  - feature of luteinization
  - in female reproductive tissues
- Angiogenic growth factors
- Angiography
- Angiopoietins
- Anorchia
- Anorexia nervosa, 382. See also Eating disorders
  - clinical symptoms of
  - diagnosis of
  - metabolic abnormalities
  - subtypes
  - treatment of
- Anosmia
- Anovulation
  - abnormal feedback signals
    - estrogen concentrations
    - LH surge failure
  - adrenal gland and
  - aromatase inhibitors See (Aromatase inhibitors)
  - bleeding

- curettage
- estrogen therapy
- estrogen-progestin therapy
- pathophysiology
- progestin therapy
- treatment of

causes

central defects

- abnormal gonadotropin secretory dynamics
- hyperprolactinemia
- pituitary tumors

classification of ovulatory disorders

- World Health Organization, descriptions of

clomiphene citrate

clomiphene-resistant

definition

diagnosis of

hyperprolactinemia and

hypothalamo-pituitary-ovarian axis

laparoscopic ovarian drilling

letrozole

local ovarian conditions

obesity

oral contraceptives and

ovarian autocrine and paracrine mechanisms

pathophysiology

pretreatment evaluation and treatment

Antagonists

- antiestrogens

  - long-acting

  - physiologic

  - short-acting

Antiandrogens

Antiestrogens

- pure

- tamoxifen

Anti-müllerian hormone (AMH)



Antiphospholipid syndrome

aspirin

definition for

heparin

treatments for

Antiprogestins

Antithrombin III

Antral follicle

count

Apoproteins

Apoptosis

inhibition of

Arachidonic acid

Arcuate nucleus

Arcuate uterus

5 $\alpha$ -reductase deficiency

5 $\alpha$ -reductase enzyme

5 $\alpha$ -reductase reactions

Aromatase (P450arom) deficiency

Aromatase inhibitors

anastrozole (Arimidex)

breast cancer

breast cancer treatment and

exemestane (Aromasin)

letrozole (Femara)

results of

treatment regimens

Aromatase transcription

Aromatization

Array comparative genomic hybridization (aCGH)

ART. See Assisted reproductive technologies

Arterial thrombosis

oral contraception

stroke

Artificial insemination. See Intrauterine insemination

Artificial ovary

Asherman's syndrome

amenorrhea and other problems hysteroscopy and

Aspirin

Assisted reproductive technologies (ART), 1248, . See also individual techniques

definition

fertility preservation

gamete intrafallopian transfer

gestational surrogacy

male factor infertility and

oocyte cryopreservation

oocyte donation and

ovarian stimulation regimens

sperm retrieval

tubal surgery in

    distal tubal obstruction

    prognosis for successful pregnancy after microsurgical sterilization

    proximal tubal obstruction

unexplained infertility

in vitro fertilization

zygote intrafallopian transfer

Asthma

    hormone therapy implications for women

    premenstrual

Asymptomatic intramural myomas

Athletes

    critical weight hypothesis

    low leptin levels and

    oral contraception

Atrial natriuretic peptide (ANP)

Autism

Autocrine communication

Autocrine-paracrine system

Autoimmune diseases

Autoimmune disorders

    screening for

Autosomal dominant mutations

Autosomal recessive

## **B**

Backdoor pathway  
Bacterial vaginosis, oral contraception  
Balloon catheters  
Barrier methods, history of  
Basal body temperature (BBT)  
    advantage of BBT charting  
    time of ovulation  
Basal FSH and estradiol concentrations  
Basal serum estradiol concentration  
Bayley-Pinneau table  
    for accelerated girls  
    for average girls  
    for delayed girls  
Bazedoxifene (BZA)  
Bellergal  
Benign breast disease  
    breast cancer  
    oral contraception  
BERKO mice  
Beta-defensin 126  
Beta-hCG  
    ectopic pregnancy and serum concentration  
    multiple pregnancy and serum concentration  
    placenta-specific expression of  
Beta-subunit  
    human chorionic gonadotropin (hCG)  
    IGF-I receptor  
    inhibin  
11 $\beta$ -Hydroxylase (P450c11) deficiency  
11 $\beta$ -Hydroxysteroid dehydrogenase  
17 $\beta$ -Hydroxysteroid dehydrogenase  
3 $\beta$ -Hydroxysteroid dehydrogenase deficiency  
17 $\beta$ -hydroxysteroid dehydrogenase deficiency  
3 $\beta$ -Hydroxysteroid dehydrogenase insufficiency  
Bicornuate uterus

Big prolactin

Bilateral benign ovarian tumors

Bioidentical hormones

Birth defects

Bisphosphonates

and osteoporosis

alendronate (Fosamax)

atrial fibrillation

and esophageal cancer

jaw osteonecrosis

pain

risedronate (Actonel)

zoledronic acid

Black cohosh

Blastocysts

Bleeding. See Abnormal uterine bleeding; Menstrual

Blood, transport of steroids

Body mass index (the Quetelet index)

nomogram for

Bone density. See also Osteoporosis

adolescence

measurement

Bone marrow–derived stem cells (BMDSCs)

Bone mass. See also Osteoporosis

Bone morphogenetic proteins (BMPs)

Bone turnover, biochemical markers

Brain and ovulation

Brain-derived neurotropic factor (BDNF)

BRCA1

DNA screening for

male carriers

BRCA2

Breast

abnormal shapes and sizes

accessory nipples

growth and development

alveolar epithelial cell, final differentiation

- changes with aging
- estrogen's influence
- pubertal response

lactation See also (Lactation)

mastalgia

polythelia

prolactin secretion

## Breast cancer

- abortion

- adjuvant therapy

- adrenal steroids

- aromatase inhibitors

- bone mass

- breast and ovarian tumor suppressor gene (BRCA1)

- dietary factors

  - alcohol

  - amount of animal fat in

  - effect of body weight on

  - soy consumption

- diethylstilbestrol (DES) and

- endogenous estrogens and androgens

- estriol and

- exogenous estrogen and progestin

- exogenous hormone use

- fibrocystic change

- frequency with age

- gonadotropins and

- hormone therapy

- and hormone therapy

  - BRCA mutations

  - breast density

  - on mammographic screening

  - outcomes

  - prevalence of

- lifetime probability of developing

- mammographic breast density

- mortality rates

needle aspiration  
oral contraception  
oral contraception and  
ovarian activity  
postmenopausal hormone therapy  
and postmenopausal hormone therapy  
    biologic plausibility  
    observational studies  
progesterone, endogenous  
prolactin and  
prophylactic mastectomy  
prophylactic oophorectomy  
raloxifene  
receptors and clinical prognosis  
reproductive experience  
reserpine  
risk and duration of hormone use  
risk factors  
    benign breast disease  
    calculate, for an individual patient  
    delayed childbearing  
    familial tendency  
    fewer children  
    high-risk families  
    lactation and  
    number of abortions  
    oophorectomy  
    pregnancy and  
screening mammography  
    digital mammography  
    effectiveness  
    microcalcifications  
    with MRI  
    with ultrasound  
survival rate  
tamoxifen  
    breast cancer prevention trials

gynecologic problems

thyroid and

thyroid, prolactin, and various nonestrogen drugs

vasomotor symptoms

Breast screening

Breast-feeding. See also Lactation

implant systems of contraception

oral contraception

prolactin adenomas and

Bromocriptine

mastalgia and

Bulimia nervosa

## C

C region

CA-125 assay

Cabergoline

Caffeine, early pregnancy loss

Calcitonin, osteoporosis and

Calcium

content of foods

premenstrual syndrome and supplementation

requirements

supplementation and osteoporosis

Calcium influx

Calcium messenger system

Calendar of Premenstrual Experiences (COPE)

Call, Emma

Call-Exner bodies

Calmodulin

Cancer

breast See (Breast cancer)

deaths in US women

endometrial See (Endometrial cancer)

implant systems of contraception and

site of incidence, in US women

thyroid

Candidate metabolic signals

Capacitation

Carbohydrate metabolism

Carbohydrate variations in

Cardiovascular disease

- C-reactive protein (CRP)

- high-density lipoprotein (HDL) levels and  
homocysteine

- lipoprotein

- metabolic syndrome

- optimal cholesterol/lipoprotein profile

- sex steroids

- tibolone, effect on

- triglycerides

Catagen

Catamenial epilepsy

- pathophysiology

- treatment

Catamenial pneumothorax

Catamenial seizures

Catechol estrogens

Caveolae

Cell-free DNA

Cellular context

Cellular mechanism of action

Centers for Disease Control and Prevention (CDC)

Central control mechanisms

- gamma-aminobutyric acid

- glutamate

- kisspeptins

- neuropeptide Y

Central medulla

Central nervous system

Cervical atresia

Cervical cancer

- screening

Cervical cap



- FemCap
- Lea's Shield
- Prentif
- Cervical cerclage
- Cervical dilation
- Cervical factor: abnormalities of sperm-mucus interaction
- Cervical pregnancy
- Cervical ripening
  - endocrinology, of parturition
- Cervical stenosis
- Cervix
  - cancer
    - IUDs and risk of oral contraception
  - mucus, structure of
- Cesarean scar pregnancy
  - ectopic pregnancy
- Cetrorelix
- CFTR gene
- Childhood and early adolescence
- Chlamydia
  - antibody tests
  - oral contraception
- Chloasma, oral contraception
- Cholestatic jaundice, oral contraception
- Cholesterol
  - cholesterol-lipoprotein profile abnormal
  - HDL cholesterol
  - optimal cholesterol/lipoprotein profile
- Cholesterol-lipoprotein profile
- Chorea
- Choriocarcinoma
- Chromatin immunoprecipitation (ChIP)
- Chromosomal abnormalities
- Chromosomal anomalies
- Chromosome walking
- Chromosomes

gene function

meiosis

mitosis

pairing and splitting of

Chromotubation

Chronic cervicitis

Chronic endometritis

Chronic illness

Chronic systemic illness

Chylomicrons

Citalopram (Celexa)

Clathrins

Climacteric

Cloacal exstrophy

Clomiphene

Clomiphene citrate

cervical mucus

challenge test

clinical indications for

endometrial growth and development

glucocorticoids and

hCG

induction of ovulation

mechanism of action

metformin and

ovary and embryo

peripheral actions

pharmacology of

enclomiphene

zuclomiphene

preliminary suppressive therapy

results of treatment

risks of treatment

breast cancer

miscarriage

multiple pregnancy

ovarian cancer

- ovarian hyperstimulation syndrome
- side effects of
  - scotomata
- treatment regimens
- unexplained infertility
- Clomiphene citrate stimulation
- Clonidine
- Cloning DNA
- Clustering
- Coated pit
- Cocaine use
- Codon
- Cognition
  - menopause
- Colony-stimulating factor-1 (CSF-1)
- Colorectal cancer
  - oral contraception
- Complementary DNA (cDNA)
- Complementary DNA library
- Complete androgen insensitivity
- Computer-assisted sperm analysis (CASA)
- Condom
  - breakage
  - female condom
  - instruction for use
  - polyurethane
  - types of condoms available
- Congenital adrenal hyperplasia (CAH)
  - 11 $\beta$ -hydroxylase (P450c11) deficiency
  - 3 $\beta$ -hydroxysteroid dehydrogenase deficiency
  - fertility and pregnancy, CAH-affected child
  - genetic screening
  - 21-hydroxylase (P450c21) deficiency
  - screening
  - treatment
    - adults
    - pregnancy

- preimplantation genetic diagnosis
- prenatal maternal
- Congenital bilateral absence of the vas deferens (CBAVD)
- Congenital diseases
- Congenital lipoid
- Congenital uterine anomalies
- Conjugates
  - glucuroconjugates
  - sulfo conjugates
- Connexin expression
- Connexins
- Contraception
  - barrier methods of
    - cervical cap
    - condom
    - diaphragm
    - history
    - protection against sexually transmitted infections
    - risk of toxic shock syndrome
  - efficacy of
  - failure rates
  - female condom
  - implant systems See (Implant systems)
  - intrauterine device See (Intrauterine device)
  - life-table analysis
  - litigation and, s0014
  - LNG rods (two rod system)
    - Jadelle
    - Norplant-2
  - Pearl index
  - post abortion
  - Protectaid sponge
  - sexually transmitted infections (STIs)
  - spermicides
  - sponge and Today sponge
  - use and nonuse, impact
  - use in the US

## National Survey of Family Growth

withdrawal

worldwide use

Cooperativity

Cornual spasm

Corpus luteum

life span and steroidogenic capacity

Cortex

Cortical granules

Cortical reaction

Corticosteroid-binding globulin

Corticosteroids, prostaglandin inhibition

Corticotroph adenomas

Corticotropin-releasing hormone (CRH)

amenorrhea and

system

Cortisol excess, causes

C-reactive protein (CRP)

cardiovascular disease

estrogen treatment

raloxifene

tibolone

CRH. See Corticotropin-releasing hormone

CRH stimulation test

Critical illness

Critical weight hypothesis and

Cryopreservation

embryo

embryo and mature oocyte

oocyte

ovarian tissue

combination of ovarian tissue with assisted reproductive technologies

freezing techniques

menopause and premature ovarian failure

potential complications

transplantation locations

whole ovary

Cryptorchidism  
Cumulus oophorus  
CuSAFE-300  
Cushing's syndrome  
    ACTH-dependent  
    ACTH-independent  
    dexamethasone-CRH test  
    diagnosis  
    24-hour urinary free cortisol excretion  
    late-night salivary cortisol level  
    midnight serum cortisol concentration  
    overnight dexamethasone suppression test  
Cyclic AMP  
Cyclic AMP mechanism  
Cyclic AMP-responsive element (CRE)  
Cyclofem  
Cyclo-oxygenase enzyme  
Cyclo-oxygenase pathway  
CYP19 gene  
Cyproterone acetate, hirsutism and  
Cystic fibrosis, screen for  
Cytochrome P450  
Cytochrome P-450 aromatase enzyme  
Cytokines  
Cytotrophoblasts

## **D**

D region  
da Vinci, Leonardo  
Dalkon Shield  
Danazol  
    mastalgia and  
Danish Nurse Cohort  
DAX1  
D-Chiro-inositol  
Decidua  
    prolactin synthesis

Decorin

Deep infiltrating endometriosis (DIE)

Dehydroepiandrosterone (DHEA)

Dehydroepiandrosterone sulfate (DHEAS)

hirsutism and

levels after

production

Dehydrogenase reactions

Delayed puberty

laboratory evaluation

relative frequency of abnormalities

treatment of

Dementia

menopause

Density gradient centrifugation

Deoxyribonucleic acid (DNA)

microarrays

polymerase

polymorphism

probe

replication

sequencing

sperm chromatin structure and

structure and function of

Depo-Provera (depot-medroxyprogesterone acetate)

injectable contraception See (Injectable contraception)

sickle cell disease and

Depot-medroxyprogesterone acetate, 523, 525, 916, 930. See also Depo-Provera

Depression

oral contraception

St. John's wort

Desmolase reaction

Desmopressin

Desogestrel

Desvenlafaxine succinate (Pristiq)

Dexamethasone, hirsutism and

Dexamethasone-CRH test

DHA. See Dehydroepiandrosterone  
DHEAS. See Dehydroepiandrosterone sulfate  
DHT. See Dihydrotestosterone  
Diabetes insipidus  
Diabetes mellitus

- early pregnancy loss
- hormone therapy implications for women
- oral contraception
- postmenopausal hormone therapy and

Diaphragm

- benefits
- care of
- choice and use of
- efficacy
- fitting
- reassessment
- side effects
  - prophylactic antibiotic
  - urinary tract infections
  - vaginal abrasion or mucosal irritation
- timing

Dienogest  
Diet, estrogen level variations  
Diethylstilbestrol (DES)

- breast cancer in women exposed to
- risk for ectopic pregnancy

Dihydrotestosterone (DHT)  
Dihydroxyphenylalanine (DOPA)  
Dihydroxyprogesterone  
Dihydroxyprogesterone acetophenide  
Dimerization  
Diminished ovarian reserve (DOR)  
Diplotene  
Discriminatory zone concept  
Discriminatory zone in transvaginal ultrasound  
Disorders of sexual development (DSD)

- chromosome



45,X (Turner syndrome and variants)  
45,XX/46,XY (chimerism)  
45,X/46,XY (mixed gonadal dysgenesis)  
47,XXY (Klinefelter syndrome and variants)

gonadal (ovarian) development

46,XX

androgen excess, fetoplacental origin  
congenital adrenal hyperplasia  
genital development  
gestational hyperandrogenism

46,XY

androgen action  
androgen synthesis  
antimüllerian hormone  
gonadal (testicular) development  
LH receptor defects  
steroid 5 $\alpha$ -reductase deficiency

Distal tubal obstruction

Djerassi, Carl

DNAase

DNA-binding domain

Dominant follicle

Dopamine

agonists

indications for  
induction of ovulation with  
results of  
risk factors of  
side effects of  
treatment regimens

tract

Dot or slot blotting

Double uterus

Down syndrome

Down-regulation of receptors

Drospirenone

Drug ingestion

## Drugs

### Dysfunctional uterine bleeding

- abortion
- anovulation
- differential diagnosis
- terminology

### Dysmenorrhea

- diagnosis
- endometriosis
  - in adolescents
- epidemiology
- inhibitors of prostaglandin synthesis
- nonsteroidal anti-inflammatory agent
- pathophysiology
- prevalence of
- primary
- prostaglandin  $F_{2\alpha}$  ( $PGF_{2\alpha}$ )
- secondary
- treatment

## E

E. nodatum and IUD use

E region

Ear diseases, oral contraception

Early pregnancy factor (EPF)

Early pregnancy loss. See also Miscarriage

- aging and aneuploidy
- screening

- alcohol consumption

- alloimmune disorders

- antiphospholipid antibodies

- antiphospholipid syndrome

- autoimmune disorders

- caffeine and

- congenital uterine malformations

- defined

- diabetic women
- endocrine factors
- environmental factors
- epidemiology of
- factor V Leiden mutation
- genetic factors
- gonadotropins and
- hysteroscopic septoplasty
- immunologic factors
- incidence of
  - increase with age
- infectious causes
- inherited thrombophilias
- intrauterine adhesions (Asherman's syndrome) 104
- karyotyping
  - abnormal
- leiomyomas and
- metformin
- parental chromosomal abnormalities
  - balanced reciprocal translocation
  - chromosomal inversions
- PCOS
- preimplantation genetic diagnosis
- progesterone concentrations
- risk of recurrent in young women
- smoking and
- summary of evaluation and treatment for
- systemic lupus erythematosus
- transvaginal ultrasound
  - embryonic heart activity
  - prognostic value
- unexplained recurrent

Eating disorders. See also Bulimia nervosa

- oral contraception
- pregnancy and

Ectopic ACTH-secreting tumors

Ectopic pregnancy

abdominal pregnancy  
abdominal surgery  
abortion  
cervical pregnancy  
cesarean scar pregnancy  
culdocentesis  
expectant management of  
fimbrial evacuation of  
heterophilic antibodies  
heterotopic pregnancy and  
indications for salpingectomy  
infertility and risk  
interstitial pregnancy  
IUDs and  
linear salpingostomy  
medical treatment of  
methotrexate  
    treatment regimens for ectopic pregnancy  
oral contraception and  
ovarian pregnancy  
progesterone serum concentrations in ectopic pregnancy  
    recovery of chorionic villi  
prognostic indicators  
    biochemical characteristics  
    ultrasonographic characteristics  
risk factors  
screening for  
serum  $\beta$ -hCG concentration  
sites of implantation  
sterilization  
surgical treatment for  
    outcomes of  
    persistent  
symptoms of  
transvaginal ultrasonography  
tubal pathology and risk  
tubal sterilization

- uterine curettage
  - catheter biopsy
  - vaginal douching
- Eflornithine hydrochloride (Vaniqa)
  - hirsutism and
- Egg. See also Oocyte
  - transport
- Eicosanoids
- Elagolix
- Elderly
  - compression of morbidity
  - growth of the older population
  - life expectancy
    - for women
  - percent elderly in US population
- Electroejaculation
- Electrolysis
- Embryo and mature oocyte cryopreservation
  - age
  - delay in cancer treatment
  - genome activity
  - hormone sensitivity of malignancies
  - human pregnancy
- Emergency postcoital contraception
  - danazol
  - insertion of a copper IUD
  - levonorgestrel
  - mechanism and efficacy
  - mifepristone
  - Plan B, NorLevo, Vikela
  - risk of venous thromboembolism
  - treatment method
- Empty sella syndrome
- Enclomiphene
- Endogenous opiates
- Endometrial biopsy
- Endometrial cancer

Depo-Provera and risk of  
oral contraception and  
Endometrial cells  
Endometrial dating  
Endometrial hyperplasia  
    with atypia  
    without atypia  
Endometrial neoplasia  
    progress to frank cancer  
    risk of in women on estrogen therapy  
Endometrial polyps  
Endometrial tissue  
Endometrioid tumors  
Endometriosis  
    "add-back" treatment strategies and regimens  
    in adolescents  
    age at time of diagnosis  
    aromatase inhibitors  
    associated with mild disease  
    CA-125 assay  
    classification and staging systems  
    clinical diagnosis of  
    coelomic metaplasia theory  
    Danazol  
    definition  
    endometriosis-associated infertility, treatment of  
        ovulation induction and assisted reproductive technology  
        surgical treatment  
    epigenetic changes  
    estrogen-progestin contraceptives  
    genetics of  
    GnRH and  
        agonists  
        antagonist  
    hormonal therapeutics  
    hysterectomy  
    imaging and

immunobiology of  
infertility, mechanisms of  
laparoscopic uterosacral nerve ablation  
laparoscopy  
laparotomy  
medical treatment  
molecular mechanisms  
    estrogen production  
    progesterone resistance  
    prostaglandin production  
nonhormonal and investigational  
nonsteroidal anti-inflammatory medications  
pain  
    mechanisms of  
    severity  
pathogenesis of  
preimplantation genetic diagnosis  
    stem cells  
presacral neurectomy  
prevalence of  
progestins  
results of medical treatment  
    fertility  
    volume of disease  
surgical diagnosis  
    laparoscopy  
    peritoneal implant  
surgical treatment  
    conservative surgery  
    definitive surgery  
    multimodal approach  
    postoperative medical therapy  
as systemic disorder  
tamoxifen and  
in vitro fertilization (IVF) and  
Endometriosis Association  
Endometriosis fertility index (EFI)

Endometritis

chronic

IUD use and

Endometrium

ablation

abnormal uterine bleeding and

angiopoietins

breakdown

cancer

ciliated and microvillous cells

decidua

endothelins

fibronectin

histologic changes, ovulatory cycle

hyperplasia

    progestin therapy

implantation phase

insulin-like growth factor-binding proteins

integrins

laminin

lipids

lysosomal membrane

matrix metalloproteinase

menstrual

methods

nucleolar channel system

peptides

products

progesterone withdrawal

proliferative phase

prostaglandin content

results

secretory phase

stratum compactum

stratum spongiosum

teleologic theory

tibolone, effect on



- tumor necrosis factor- $\alpha$
- uteroglobin
- Endorphin
- $\beta$ -Endorphin
- Endothelin-1
- Endothelins
- Enhancer
- Enkephalin
- Environment, gender identity
- Enzymes
  - 5 $\alpha$ -reductase enzyme
  - proteolytic
- Ephrins
- Epidermal growth factor (EGF) receptor
- Epididymal sperm aspiration
- Epididymis
- Epigenetics
- Epigenomics
- Epilepsy
- 17-epitestosterone
- Equol
- ERKO mice
- Estes procedure
- Estradiol
  - perimenopausal transition
  - polycystic ovary and levels
- Estradiol enanthate
- Estrane nucleus
- Estring, systematic absorption of estrogen
- Estriol
  - breast cancer and
  - postmenopausal hormone therapy
- Estrogen. See also Postmenopausal hormone therapy
  - agonists/antagonists
  - conversion of androstenedione to
  - endogenous, breast cancer and
  - exposure to unopposed

negative feedback of  
postmenopausal estrogen deprivation  
in pregnancy

amniotic fluid estrogen measurements  
estetrol

progesterone, positive feedback response  
receptors

expression  
GnRH neurons

steroid hormone, pregnancy  
therapy, as therapy for anovulation  
high-dose oral estrogen treatment  
intravenous estrogen therapy  
thromboembolism risk

verbal memory

Estrogen receptor expression

Estrogen receptor-alpha (ER- $\alpha$ )  
homology

Estrogen receptor-beta (ER- $\beta$ )  
homology

Estrogen replacement and atherosclerosis trial, (ERA)

Estrogen therapy  
and age-related hearing loss  
and autoimmune diseases  
and larynx  
and oral cavity  
and osteoarthritis  
and vision

Estrogen threshold hypothesis

Estrogen–progestin hormonal contraceptives  
hirsutism and

Estrogen-progestin therapy. See Postmenopausal hormone therapy

Estrogens

Ethinyl estradiol

Ethisterone

Ethinodiol diacetate

Eugonadotropic hypogonadism

Eukaryotes

Evening primrose

Exaggerated thelarche

Excretion of steroids

Exercise

- amenorrhea and

- negative energy balance and

- runner's "high,"

Exogenous gonadotropins

Exon

Eye diseases

- oral contraception

## **F**

F region

Factor V Leiden mutation

- carrier frequencies of the Leiden mutation

- early pregnancy loss

- venous thromboembolism, oral contraception and

Fallopian tube

Fallopio, Gabriele, 72. See also Fallopius

Fallopius

False-positive tests

Fecundability

Fecundity

Feedback system

Female condom

Female infertility

- abnormalities of semen quality

- adoption

- alcohol intake

- basal body temperature (BBT) and

- causes of

  - male factors

  - ovulatory dysfunction

  - tubal and peritoneal pathology

- cervical factor: abnormalities of sperm-mucus interaction

chlamydia antibody tests  
chronic endometritis  
cocaine use  
coitus, timed  
congenital uterine anomalies and  
delay childbearing among American women  
endometrial biopsy  
endometrial dating  
endometrial polyps  
epidemiology of  
evaluation and treatment of  
hysterosalpingography and  
hysteroscopy  
indications for evaluation  
infertility and sperm-mucus interaction abnormalities  
infertility evaluation, female  
    history  
    physical examination  
    screen for cystic fibrosis  
    screen for rubella immunity  
    screen for sexually-transmitted infections  
    screen for varicella (chicken pox)  
intrauterine adhesions (Asherman's syndrome)  
intrauterine insemination See (Intrauterine insemination)  
laparoscopy  
lifestyle and environmental factors  
luteal phase deficiency  
    prevalence of  
male factor  
marijuana  
menstrual history and  
normal reproductive efficiency  
ovarian reserve and its assessment  
ovulatory dysfunction  
postcoital test  
preliminary evaluation of infertile couple  
    screening tests

prostaglandin synthase inhibitors (NSAIDs)  
saline sonohysterography  
serum progesterone concentration  
smoking and  
sonohysterography  
time required for conception  
transvaginal ultrasonography  
tubal factor: tubal occlusion and adnexal adhesions  
tubal surgery  
    distal tubal obstruction  
    prognosis for successful pregnancy after microsurgical sterilization  
    proximal tubal obstruction  
unexplained  
    assisted reproductive technology  
    clomiphene citrate and  
    combined treatment, clomiphene citrate stimulation and IUI  
    combined treatment, exogenous gonadotropins and IUI  
    exogenous gonadotropins and  
    incidence of  
    IUI  
    ovarian stimulation  
    treatment of  
urinary LH excretion  
uterine factor: anatomic and functional abnormalities  
uterine myomas  
weight and

Female pseudohermaphrodite

FemCap

Feminizing hormone therapy (estrogen formulations)

Ferning

Ferriman-Gallwey (FG) scoring system

Fertility

aging and

    adverse effect of

    genetics of

    inhibin B levels

    mechanisms of age-related decrease in fertility

- number of remaining follicles
- physiology of reproductive aging
- rise in circulating FSH concentrations

- male

- and sterility

- Fertility preservation

- cryopreservation

- embryo and mature oocyte

- ovarian tissue

- future prospects

- indications

- associated with advanced age

- malignant diseases

- nonmalignant conditions

- ovarian protection, medical management

- Fertilization

- cortical reaction

- Fetal adrenal cortex

- Fetal breathing

- Fetal circulation

- Fetal life and infancy

- Fetal lung maturation

- Fetus

- physiology of thyroid gland

- thyroid hormones

- FGF9

- Fibrinolysis

- Fibroblast growth factor (FGF)

- Fibroids, uterine. See Leiomyomas

- Fibronectin

- Finasteride

- Flagellum

- Flare effect

- FlexiGard

- Fluorescence in situ hybridization (FISH)

- Fluoride

- Fluoxetine (Prozac)

premenstrual syndrome and

Flutamide

Follicle

antral

connexin expression

formation

growth and development

LH's role in development

preantral

preovulatory

primordial

selection of the dominant

theca vascularity

two-cell, two-gonadotropin system

Follicle stimulating hormone (FSH)

biologic activity

hyaluronic acid response to

levels increase during puberty

midcycle surge of

negative feedback of estrogen on

peak of

perimenopausal transition

progesterone, responsible for FSH surge

receptors for

surge

Follicular depletion

Follicular isolation technique

Follicular loss, due to posttransplantation ischemia

Follicular phase

duration of time to achieve preovulatory status

recruitment

Follistatin

forms of

FOXL2

Fragile X syndrome

FRAX, World Health Organization fracture risk assessment tool

Free hormone

Frisch

FSH. See Follicle stimulating hormone

Fumarate hydratase

## G

G protein receptors

Gabapentin (Neurontin)

Galactorrhea

- clinical problem

- differential diagnosis

- implant systems of contraception and

Galactosemia

Gamete intrafallopian transfer (GIFT )

Gamma-aminobutyric acid (GABA)

Gap junctions

Gender ambiguity/feminization of external genitalia

Gender dysphoria in children and adolescents

Gender identity

- biologic determinants

  - environment

  - genetics

  - hormones

  - structural determinants

Gender reassigning surgery

Gender-affirming hormone therapy, TG endocrinology

- in adolescents

- in adults

  - feminizing hormone therapy (estrogen formulations)

  - masculinizing hormone therapy (testosterone formulations)

Gene expression profiling

Gene function

- epigenetics

- transcription

- translation

Gene locus

Genes

- identification of



- DNA polymorphism
- Human Genome Project
- structure of
- Genetic and epigenetic variation
  - chromosomal abnormalities
  - and genomic imprinting
  - polygenic traits and disorders
  - single-gene sequence variation
- Genetic diagnosis, preimplantation. See Preimplantation genetic diagnosis
- Genetics
  - chromosomes
    - gene function
    - meiosis
    - mitosis
    - pairing and splitting of
  - clinical applications
    - diagnosing genetic disorders
    - personal genomics
    - preimplantation genetic testing
  - DNA, structure and function of
  - gender identity
  - gene structure
  - genes
    - DNA polymorphism
    - Human Genome Project
  - genetic and epigenetic variation
    - chromosomal abnormalities
    - and genomic imprinting
    - polygenic traits and disorders
    - single-gene sequence variation
  - human genome
- Genitourinary syndrome
  - of menopause
- Genome-wide association studies (GWAS)
- Genomic imprinting
- Genomics
- Germ cells

- germ cell mass
- loss of
- sex differentiation
- Gestational diabetes
  - oral contraception
- Gestational hyperandrogenism
  - drug ingestion
  - pregnancy luteoma
  - theca-lutein cysts
- Gestodene
- Genetics of reproductive aging
- Ghrelin
- Ginkgo biloba
  - Alzheimer's disease
- Glucocorticoids
  - hirsutism and
- Glucose tolerance test, baseline 2-hour
- Glutamate
- Glycodelin
- GnRH associated peptide (GAP)
- GnRH-II
- GnRH-like peptides
- Gonad
  - differentiation
  - stage of
  - maximum oögonia
- Gonadal (testicular) development disorders
  - partial gonadal dysgenesis
  - Swyer syndrome
  - testicular regression syndrome
- Gonadal (ovarian) developmental disorders
  - gonadal dysgenesis
  - true hermaphroditism
  - 46,XX sex reversal
- Gonadal dysgenesis
  - complete
  - partial

- XX karyotype
- XY karyotype
- Gonadal steroids
- Gonadotoxicity
- Gonadotoxins
- Gonadotroph adenomas
- Gonadotropin
  - action of GnRH on secretion
  - sex difference, fetal levels
  - synthesis
  - through fetal life, childhood, and puberty
- Gonadotropin secretory dynamics, abnormal
- Gonadotropin-dependent precocious puberty
- Gonadotropin-independent precocious puberty
- Gonadotropin-releasing hormone (GnRH)
  - agonist(s)
    - abnormal uterine bleeding, treatment in clinical use
    - decreasing ovarian tissue damage
    - side effects with and steroid add-back
    - treatment for premenstrual syndrome
    - treatment of leiomyomas
  - analogs
  - antagonist(s)
    - in clinical use
  - cells that produce estrogen receptors in neurons
  - feedback effects
  - on gonadotropin elaboration
  - half-life
  - hirsutism treatment with agonist
  - hypothalamus and induction of ovulation with
    - indications for
    - monitoring treatment

results of  
treatment regimens  
pituitary response to  
pulsatile secretion  
control of  
timing of  
secretion  
self-priming action  
treatment of leiomyomas

## Gonadotropins

amenorrhea and  
induction of ovulation with  
breast and ovarian cancer  
indications for  
monitoring therapy  
multifetal pregnancy reduction  
multiple pregnancy  
ovarian hyperstimulation syndrome  
results of treatment  
risks of treatment  
sequential treatment with  
serum estradiol levels  
step-down regimen  
step-up regimen  
treatment regimens  
ultrasonography

## Gonococcal disease

## Graafian follicle

## Gräfenberg ring

## Grandfather effect

## Granulosa

anti-müllerian hormone and  
aromatase activity of  
cells  
LH receptors

## Graves' disease (toxic diffuse goiter)

## Growth

factors  
growth spurt timing, girl's  
hormone  
insulin-like growth factor-I (IGF-I)  
problems in normal adolescents  
    short stature  
    tall stature

Growth differentiation factor-9

Growth hormone–releasing hormone

## H

HABITS trial

Hair. See also Hirsutism

    anagen  
    androgens in women  
    catagen  
    dehydroepiandrosterone sulfate  
    difference between races and ethnic groups  
    embryology  
    follicle  
    growth  
        cycle  
        factors that influence  
    hyperthyroidism and  
    hypertrichosis  
    lanugo hair  
    permanent removal  
    steroidogenic hormone pathway  
    telogen effluvium  
    terminal hair  
    vellus hair

Haplotypes

Harvey, William

hCG. See Human chorionic gonadotropin

hCT. See Human chorionic thyrotropin

HDL. See High-density lipoproteins

Headache, menstrual

Health and wellness, TG endocrinology  
health screening recommendations  
mental health

Heart and estrogen-progestin replacement study (HERS)

Heat shock protein 90

Hemochromatosis

Hemoptysis

Hemothorax

Hereditary hemochromatosis

Hermaphrodite

true

Hermaphroditism

Hernia uterine inguinale syndrome

HERS. See Heart and Estrogen-Progestin Replacement Study (HERS)

Heterotopic pregnancy

Heterotopic transplantation

High-density lipoproteins (HDL)

cardiovascular disease

protective nature of

High-dose dexamethasone suppression test

Hirsutism. See also Hair

3 $\alpha$ -androstanediol glucuronide

acanthosis nigricans

ACTH secretion

17 $\alpha$ -hydroxyprogesterone level

androgen-producing tumor

androgens in women

antiandrogens

3 $\beta$ -hydroxysteroid dehydrogenase insufficiency

causes

congenital adrenal hyperplasia

Cushing's syndrome

definition

dehydroepiandrosterone sulfate

dexamethasone

diagnostic workup for

estrogen-progestin hormonal contraceptives

evaluation of women  
family history  
Ferriman-Gallwey scoring system  
glucocorticoids  
gonadotropin-releasing hormone agonists  
hair-stimulating drugs  
21-hydroxylase defect  
idiopathic  
imaging of the adrenal glands and ovaries  
insulin resistance  
insulin-sensitizing drugs  
laboratory evaluation of  
menstrual history  
nonclassical congenital adrenal hyperplasia  
oral contraception  
ovarian tumors  
PCOS  
physical examination  
serum DHEA-S concentration  
serum testosterone concentration  
SHBG production in liver  
testosterone levels  
treatment  
    combination therapy  
    cyproterone acetate  
    dexamethasone  
    eflornithine hydrochloride (Vaniqa)  
    electrolysis  
    estrogen–progestin hormonal contraceptives  
    finasteride  
    flutamide  
    glucocorticoids  
    gonadotropin-releasing hormone agonists  
    laser and pulsed light therapies  
    minoxidil  
    oral contraceptives  
    spironolactone

Homeobox A10 (HOXA10)

Homeobox (HOX) genes

Homocysteine

- cardiovascular disease

- postmenopausal hormone therapy

Hormonal replacement therapy After Breast cancer—Is it Safe (HABITS)

Hormone regulation

Hormone replacement therapy. See Postmenopausal hormone therapy

Hormone therapy. See also Postmenopausal hormone therapy

- amenorrhea and

- bone density and

- breast cancer, side effects

Hormone-binding domain

Hormone-receptor processing

Hormone-responsive elements

Hormones. See also Specific hormones

- alpha-subunit

- beta-subunit

- biologic activity, determining factors

- blood concentrations during female puberty

- conformational shape

- definition of

- feedback system and

- gender identity

- ghrelin

- levels at menopause

- maternal thyroid hormones

- nomenclature

- perimenopausal transition, levels during

- profile of menopausal transition and postmenopause

- tropic

  - heterogeneity

  - mechanism of action

  - regulation of

Hot flush

- alternative therapies

- physiology of



- placebo response
- premenopausal women experiencing
- prevalence
- randomized clinical trial
- tibolone, effect on
- treatment options
- 24-hour urinary free cortisol excretion
- hPL. See Human placental lactogen
- Hulka-Clemens spring clip
- Human chorionic adrenocorticotropin
- Human chorionic gonadotropin (hCG)
  - clomiphene and
  - fetal
- Human chorionic somatomammotropin. See Human placental lactogen
- Human chorionic thyrotropin
- Human Genome Project
- Human immunodeficiency virus (HIV)
  - IUD use and
  - oral contraception and
- Human menopausal gonadotropin
- Human parturition
  - cortisol
  - metalloproteinases
  - oxytocin and myometrial responses
  - progesterone maintenance
  - prostaglandin regulation
- Human placental lactogen (hPL)
  - clinical uses
  - physiologic function
- Human pregnancy
- Human reproductive process
- Human zona binding assay
- Hutterites and fertility
- Hyaluronic acid response
- Hybridization
- 12-Hydroxyeicosatetraenoic acid (12-HETE)
- Hydroxyindole-O-methyltransferase (HIOMT)

melatonin synthesis

21-Hydroxylase defect

17 $\alpha$ -Hydroxylase deficiency

21-Hydroxylase (P450c21) deficiency

Hydroxylation reaction

17-Hydroxyprogesterone (17-OHP)

17 $\alpha$ -Hydroxyprogesterone

Hyperactivated motility

Hyperandrogenic insulin-resistant acanthosis nigricans (HAIR-AN) syndrome

Hyperandrogenism

adolescent with PCOS

body mass index

diabetes mellitus, increased risk and  
gestational

hyperinsulinemia as the primary factor

insulin receptor

insulin resistance

metformin

polycystic ovary and

therapy for lifestyle modification

Hypergonadotropic hypogonadism

Hyperinsulinemia

body mass index

D-chiro-inositol

gestational diabetes and

greater risk of early miscarriage and gestational diabetes

leptin levels and

pioglitazone

polycystic ovary and

postmenopausal hormone therapy

rosiglitazone

thiazolidinediones

troglitazone

type B syndrome

type C syndrome

waist circumference and

Hyperlipidemia

Hypermenorrhea

Hyperprolactinemia

anovulation and

Hyperreactio luteinalis

Hypertension

Hyperthecosis

Hyperthyroidism

diagnosis

subclinical

Graves' disease (toxic diffuse goiter)

hair and

Plummer's disease (toxic nodular goiter)

in pregnancy

treatment

thyrotoxicosis

treatment

antithyroid drugs

methimazole

Hypertrichosis

Hypogonadism

eugonadotropic

hypergonadotropic

hypogonadotropic

Hypogonadotropic hypogonadism

Hypothalamic amenorrhea

Hypothalamic or pituitary tumors

Hypothalamic-hypophyseal portal circulation

Hypothalamic-like releasing hormones

placental corticotrophin-releasing hormone

placental gonadotropin-releasing hormone

placental growth hormone-releasing hormone

placental thyrotropin-releasing hormone

Hypothalamic-pituitary disorders

Hypothalamic-pituitary-gonadal axis

central control mechanisms

gamma-aminobutyric acid

glutamate

kisspeptins

neuropeptide Y

childhood and early adolescence

fetal life and infancy

peripheral signaling

candidate metabolic signals

leptin

puberty

Hypothalamus

action of progesterone on

arcuate nucleus

and GnRH secretion

hypothalamic amenorrhea

Hypothyroidism

diagnosis

early pregnancy loss

evaluation of therapy

galactorrhea

increases with aging

more common in women

newborn screening for

in pregnancy

subclinical hypothyroidism

treatment

Hysterosalpingo-contrast sonography

Hysterosalpingography (HSG)

Hysteroscopy

abnormal uterine bleeding

septoplasty, early pregnancy loss and

## I

Ibuprofen

ICSI. See Intracytoplasmic sperm injection

Idiopathic hirsutism

Idiopathic male infertility

IDL. See Intermediate-density lipoproteins

IGF. See Insulin-like growth factor

IGF-1

IGFBP-1

IL-1

IL-8

Immune conjugate (ICON)

Imperforate hymen

Implanon, 917, 918. See also Implant systems

Implant systems of contraception

absolute contraindications

advantages of

amenorrhea and

body weight, effect on levonorgestrel

bone density in young women

breast milk, effects on

breast-feeding and

carbohydrate metabolism

common patient questions

counseling women

disadvantages of

bleeding patterns

complicated removals

cost of

protection against sexually transmitted infections (STIs)

efficacy

pregnancy rates by weight

weight restrictions for

fertility effects of

Implanon

contraceptive efficacy of

etonogestrel

inhibits ovulation

menstrual patterns altered

indications

insertion and removal

insertion technique, f0003, f0004

complications

incision and placement

required equipment

Jadelle

lipoprotein profile

LNG rods (two rod system)

mastalgia

mechanism of action

menstrual effects

metabolic effects of

Norplant

ectopic pregnancy

other medical eligibility criteria

plasma concentrations, of levonorgestrel

rate during Norplant

reasons for termination

removal techniques

difficult removals

with instruments

reinsertion

return of fertility, after

side effects of levonorgestrel implant users

treatment for bleeding

Uniplant

user acceptance

weight change

Implantation

adhesion

apposition

integrins

invasion

phase

placentation

preimplantation signaling

preparation

production of hCG before

In vitro activation (IVA)

ovarian tissue freezing

In vitro fertilization (IVF)

- congenital bilateral absence of the vas deferens
- congenital malformations
- cystic fibrosis and
- ectopic pregnancy and
- embryo cryopreservation
  - success rates for transfer cycles
- embryo culture
  - co-culture systems
  - extended (blastocyst) culture
- embryo transfer
  - assisted hatching
  - number of embryos to transfer
  - potential pitfalls
  - SART/ASRM guidelines
  - transfer catheters
  - transfer media
  - transfer technique
  - ultrasound guidance
- endometriosis
  - advanced
  - minimal or mild
- epididymal sperm aspiration
- evaluation before
  - embryo transfer
  - infectious disease screening
  - male factor
  - ovarian reserve
  - semen quality
  - trial transfer
  - uterine cavity
- fertilization
- indications for
  - communicating hydrosalpinges and
  - distal tubal obstruction
  - no functional uterus
  - ovarian failure and diminished ovarian reserve
  - ovulatory disorders

intracytoplasmic sperm injection

luteal phase support

progesterone

supplemental doses of hCG

male factor infertility and

genetic evaluation for men with oligospermia

MESA

multiple pregnancy and

offspring from

cancer

chromosomal, genetic, and epigenetic abnormalities

congenital anomalies

preterm birth and low birth weight

vascular and metabolic abnormalities

offspring of

behavioral and cognitive aspects

cancer

chromosomal, genetic, and epigenetic abnormalities

congenital anomalies

large-for-gestational age babies

low birth weight

prematurity

vascular and metabolic abnormalities

oocyte cryopreservation

oocyte donation

controlled endometrial development

estrogen treatment

evaluation of recipients

gestational surrogacy

implantation window

indications for

luteal support

outcomes of

progesterone and

oocyte maturation

cytoplasm and germinal vesicle transfer

oocyte retrieval



- complications of
  - empty follicle syndrome
  - prophylactic antibiotic treatment
  - standard technique
- ovarian hyperstimulation syndrome
- ovarian stimulation regimens
  - addition of a GnRH antagonists
  - cetrorelix
  - clomiphene citrate and
  - dose of the recombinant form of hCG
  - endometrial thickness or “stripe”
  - exogenous gonadotropin stimulation and GnRH agonist “long” protocols
  - ganirelix
  - high responders, management options for
  - monitored with serum estradiol measurements and transvaginal ultrasound
  - natural cycle
  - polycystic ovary syndrome, disadvantages for
  - poor responders
  - pregnancy rates observed
  - recombinant FSH and
  - short or flare protocol
  - supplemental hMG or rLH
  - treatment with clomiphene citrate and exogenous gonadotropins
  - typical cycle of “long protocol,”
  - ultrashort GnRH agonist protocol urinary FSH and
  - urinary menotropins and
- preimplantation genetic diagnosis
  - chromosomal analysis
  - comparative genome hybridization
  - detection of single gene disorders
  - fluorescence in situ hybridization
  - next-generation sequencing
- preimplantation genetic testing
  - for aneuploidy
  - array comparative genomic hybridization
  - equipment and techniques
  - fluorescence in situ hybridization

- for monogenic disorders
- next-generation sequencing
- quantitative PCR
- single nucleotide polymorphisms
- timing of biopsy

prognostic indications for success

- clomiphene citrate challenge test

- maternal age, success rate declines with increase

retrograde ejaculation

SART/ASRM registry data

sperm retrieval techniques

testicular sperm extraction and aspiration

treatment with clomiphene citrate and exogenous gonadotropins 1309

vibratory stimulation and electroejaculation

In vitro follicle maturation

In vitro maturation (IVM)

- frozen-thawed ovarian cortical fragments

- human oocytes

- of immature follicles

Incomplete androgen insensitivity syndromes

Indomethacin

Induced abortion

Infections

Infectious mononucleosis

Infertility

- empiric ovarian stimulation and

- intrauterine insemination See (Intrauterine insemination)

male

- androgen deficiency in the aging male

- antibiotic treatment for leukocytospermia

- causes of

- chromosomal anomalies and

- chronic illness

- cystic fibrosis gene mutation

- diabetes mellitus

- drugs and

- evaluation, endocrine

evaluation, indications for  
genetic evaluation  
genetic risk associated with ICSI  
gonadotoxins  
history  
idiopathic  
marijuana  
medical treatment  
physical examination  
retrograde ejaculation  
scrotal temperature  
semen analysis  
surgical treatment for  
testicular biopsy  
transrectal ultrasonography  
transscrotal ultrasonography  
urologic evaluation  
vibratory stimulation and electroejaculation  
Y chromosome deletions

mechanisms of  
risk for ectopic pregnancy and

Infiltrative diseases

Infiltrative pituitary lesions

Inflammatory bowel disease

oral contraception

Inhibin

inhibin-A

inhibin-B

secretion

transforming growth factor- $\beta$  family

Inhibin B

Injectable contraception

absolute contraindications

advantages

breast-feeding and

continuation rates

endometrial cancer, risk of

ovarian cancer, risk of  
risk of thrombosis  
seizure  
sickle cell disease and  
breakthrough bleeding and  
correct dose  
determining menopause, in long-term users  
efficacy  
indications  
mechanism of action  
problems with  
    anaphylaxis  
    bone density, effect on  
    breast cancer  
    cancer of the cervix and  
    effect on future fertility  
    galactorrhea  
    metabolic effects of  
    risk of endometrial cancer  
    risk of ovarian cancer  
reasons for discontinuing  
relative contraindications  
weight gain

## Insulin

IGF-1 receptors and  
resistance and  
signaling

## Insulin sensitivity

oral contraception and  
polycystic ovary and

## Insulin-like growth factor binding proteins (IGFBPs)

## Insulin-like growth factors (IGF)

ovarian actions of  
receptors

## Insulin-like growth factors (IGF-I)

puberty and

## Integrins

Interleukin-1 (IL-1) system  
Intermediate-density lipoproteins (IDLs)  
Internalization  
Interphase  
Interstitial pregnancy  
Intracellular receptors  
Intracrine communication  
Intracytoplasmic sperm injection (ICSI)  
    genetic risks associated with  
    sperm retrieval  
Intracytoplasmic sperm microinjection  
Intrapituitary autocrine-paracrine system  
Intrauterine adhesions  
Intrauterine adhesions (Asherman's syndrome)  
Intrauterine device (IUD)  
    abortion, septic  
    for adolescents  
    amenorrhea and progestin containing IUD  
    conditions that can compromise success  
    congenital anomalies, risk of  
    copper IUD  
    CuSAFE-300  
    Dalkon shield  
    E. nodatum and  
    ectopic pregnancy and  
        previous ectopic pregnancies and  
    efficacy of  
    emergency postcoital contraception  
    expulsion  
    failure rate  
    FlexiGard  
    Gräfenberg ring  
    human immunodeficiency virus risk and  
    insertion  
        after a first-trimester abortion  
        breast-feeding  
        inserted at cesarean section

52 mg levonorgestrel, technique for  
patient selection  
prophylactic antibiotics  
TCu-380A  
vaginal delivery  
iron deficiency  
levonorgestrel-containing intrauterine device endometriosis and  
Lippes loop  
long-term use of  
Margulies coil  
mechanism of action  
menorrhagia, treatment of  
menstrual blood loss  
Mirena  
miscarriage, spontaneous  
Multiload-375  
myths  
Nova T  
obstetrical complications  
for older women  
Ota ring  
ParaGard  
PID and  
preterm labor and delivery, incidence of  
rate of removal  
    embedded  
    finding a displaced  
removal  
Saf-T-Coil  
side effects  
    actinomycosis infection  
    bacterial endocarditis and  
    endometritis  
    gonorrhea or chlamydia infection  
    pelvic infection and  
    vaginal bacteriosis  
use of in the U.S. and world

uterine bleeding

Intrauterine growth restriction

Intrauterine insemination (IUI)

density gradient centrifugation

donor sperms

empiric ovarian stimulation and

maternal age and

number of inseminations

ovulatory function

semen parameters and prognosis

sperm preparation for

sperm washing

swim-up

timing and technique

total motile sperm count

uterine and tubal factors

Intron

Invasion

limitation of

of trophoblasts

Ion gate channels

Ipriflavone

Irving method

Isoflavones

IUD. See Intrauterine device

IUI. See Intrauterine insemination

IVF. See In vitro fertilization

## **J**

Jost, Alfred

## **K**

Kallmann syndrome

Kallmann's syndrome

Kartagener syndrome

Kartagener's syndrome

Karyotype

Karyotyping  
KEEPS (Kronos Early Estrogen Prevention Study)  
Ketoconazole  
Kinase receptors  
Kisspeptins  
Klinefelter syndrome  
K-ras gene  
Kronos Early Estrogen Prevention Study (KEEPS)  
Kruger (Tygerberg)

## **L**

Lab-on-a-chip  
Labor. See also Parturition  
    cervical ripening  
    treatment with prostaglandin inhibition  
Laboratory values  
Lactation  
    activation of oxytocin release  
    antibodies in breast milk  
    bone density and  
    breast cancer risk and  
    breastfeeding by adopting mothers  
    calcium, secretion into milk  
    cessation of  
    colostrum  
    contraceptive effect of  
        mechanism of  
    galactorrhea  
    human placental lactogen (hPL)  
    let-down  
    milk biosynthesis  
    oxytocin  
    prolactin levels during pregnancy  
Lactic acidosis  
Lactotroph adenomas  
Laminin  
Lanugo hair



Laparoscopic ovarian drilling (LOD)

Laparoscopy

Laser and pulsed light therapies, hirsutism

Late-night salivary cortisol level

LDL (low-density lipoproteins)

Lea's Shield

Lecithin

Leiomyomas (uterine fibroids)

- with GnRH agonist

- hormone sensitivity

- incidence of leiomyosarcomas

- medical therapy

  - with GnRH agonist

  - levonorgestrel-releasing intrauterine system

  - with mifepristone

  - with ultrasound

  - with uterine artery embolization

- recurrence rate after abdominal myomectomy

- reproductive function and

- risk

- spontaneous miscarriage

Leiomyomatosis peritonealis disseminata

Leptin

- athletes, low levels and

- congenital deficiency

- insulin

- Ob gene

- in obese people

- puberty

- receptor

- reproduction and

Leptotene

Letrozole

- anovulation, treatment

- bone density in women

- PPCOS II trial

Leukemia inhibiting factor (LIF)

- Leukocytospermia
- Levonorgestrel
- Levonorgestrel-releasing intrauterine system
  - abnormal uterine bleeding
  - menorrhagia, control of
- Leydig cells
- LH. See Luteinizing hormone
- LH kits
- LIF (leukemia inhibiting factor)
- Life expectancy
  - for women
- Life rectangularization
- Life-Table Analysis
- Ligand-cell membrane extranuclear receptor activity
- Ligand-dependent, ERE-independent activity
- Ligand-dependent nuclear activity
- Ligand-independent nuclear activity
- Lipids
- Lipocortins
  - lipocortin-1
- Lipoproteins
  - cardiovascular disease
  - cholesterol-lipoprotein profile abnormal
  - oral contraception
- $\beta$ -Lipotropin
- Lippes loop
- Liver
  - oral contraception
    - acute or chronic cholestatic liver disease
    - adenomas
    - gallstones
- Liver cancer, oral contraception
- Liver disease, hormone therapy implications for women
- LNG rods (two rod system)
  - Jadelle
  - Norplant-2
- LOD (laparoscopic ovarian drilling)

Long feedback loop  
Long-acting antagonists  
Low-density lipoproteins (LDL)  
LUNA (laparoscopic uterosacral nerve ablation)  
Lung cancer  
Luteal phase  
    deficiency  
    prevalence of  
Luteal-follicular transition  
Luteinizing hormone (LH)  
    angiogenesis  
    kits  
    levels increase during puberty  
    mechanism that shuts off  
    midcycle surge of  
    receptor defects  
    receptors in granulosa cells  
    role in late stages of follicle development  
    stimulation of release  
    surge, meiosis and  
    surge, onset of  
Luteoma  
Lymphocytes  
Lymphocytic hypophysitis  
Lysosomal membrane, endometrium

## **M**

Macroadenoma  
Macrophages  
Male fertility  
    aging and  
Male infertility  
    aging and male reproductive function  
        and male fertility  
    androgen deficiency in the aging male  
    antibiotic treatment for leukocytospermia  
    causes of

chromosomal anomalies and  
chronic illness  
diabetes mellitus  
diagnosis and specific treatment  
drugs and  
evaluation  
    endocrine  
    genetic  
    indications for  
genetic evaluation  
genetic risk associated with ICSI  
gonadotoxins  
history  
idiopathic  
marijuana  
medical treatment  
physical examination  
retrograde ejaculation  
scrotal temperature  
semen analysis  
surgical treatment for  
testicular biopsy  
testicular function  
    hormone regulation  
    spermatogenesis  
transrectal ultrasonography  
transscrotal ultrasonography  
urologic evaluation  
vibratory stimulation and electroejaculation  
Y chromosome deletions

Male pseudohermaphrodite

Malignant melanoma

Malnutrition

Mammography

    digital mammography

    effectiveness

    elderly women and

false-negative rate  
magnetic resonance imaging  
microcalcifications  
screening, breast cancer  
    problems to be anticipated with  
thermography  
ultrasound

Margulies coil

Marijuana

Marker, Russell

Masculinization

Masculinizing hormone therapy (testosterone formulations)

Mastalgia

    implant systems of contraception and  
    management of  
        Bromocriptine  
        danazol  
        methylxanthines  
        tamoxifen  
        testosterone

Matrix metalloproteinases (MMPs),190

Mayer-Rokitansky-Küster-Hauser syndrome

McCune-Albright syndrome (polyostotic fibrous dysplasia)

Medroxyprogesterone acetate

    hirsutism and  
    premenstrual syndrome

Meiosis

Melanocortin receptor gene

Melanoma

    malignant  
    oral contraception

Melatonin synthesis

Menarche

    age of  
        trend toward lowering  
    critical body weight to achieve  
    mean age of

Menopausal hormone therapy. See also Postmenopausal hormone therapy

bleeding during

indications for endometrial biopsy during treatment

management strategy

unopposed estrogen

cardiovascular effects

ACE and renin level reduction

actions on heart and large blood vessels

adhesion molecules reduction

clinical trials

direct antiatherosclerotic effects

endothelial cell protection

endothelium-dependent vasodilation and antiplatelet aggregation

endothelium-independent vasodilation

fibrinolysis

glucose metabolism

homocysteine reduction

intimal thickening inhibition

lipids and lipoproteins

lipoprotein oxidation inhibition

macrophage foam cell formation inhibition

observational studies

comparable doses of progestogens

dementia and cognition

electron beam tomography

estrogen dose

health implications

and lobular breast cancer

metabolic effects

progestational component

progestational exposure, long sequential regimens

progestin intrauterine device

progestin use

sequential and continuous regimens

vasomotor symptoms

Menopause

abnormal uterine bleeding

adnexal mass  
before age 46  
aging  
androgens  
atrophic changes  
circulating hormone levels, changes in  
cognition  
definition of  
dementia  
domino effect  
dyspareunia  
FSH  
genitourinary atrophy and  
genitourinary syndrome  
growth of older population  
hormone profile  
hot flush  
involutional melancholia  
mental health  
osteoporosis  
percent elderly in US population  
recurrent urinary tract infections  
risk of depression  
sexuality  
skin thickness  
stress incontinence  
Study of Women's Health Across the Nation (SWAN)  
symptomatology  
timing of  
uterine bleeding, abnormal  
vasomotor symptoms  
wrinkles

Menorrhagia

definition

levonorgestrel-releasing intrauterine system

Menstrual cycle

activin

follicular phase  
follistatin  
FSH peak  
inhibin  
length of  
LH midcycle surge  
    life span and steroidogenic capacity  
luteal phase  
luteal-follicular transition  
luteolytic factor  
normal  
ovulation  
progesterone levels  
rise in androgen levels, midcycle  
variations in flow and length

Menstrual endometrium

Menstrual function

Menstrual history

Menstruation

    catamenial seizures and  
    characteristics of  
    duration of flow  
    endometrium  
    historical views  
    initiation of  
    matrix metalloproteinases  
    mechanisms involved, onset and cessation  
    menstrual fluid  
    normal bleeding  
    opioid peptides  
    sterilization  
    synchronization of  
    variations in cycle length  
    volume of blood

Mental health, perimenopausal transition

Mental health provider (MHP)

Mesigyna



Mestranol

Metabolic clearance rate (MCR) of steroids

Metabolic syndrome

Metabolism

- androgen

- effects of implant systems of contraception

- physiologic feedback loop

- progesterone

Metabolomics

Metalloproteinases, human parturition

Metaphase

Metformin

Methimazole

Methotrexate

- indications and contraindications

- treatment regimens for ectopic pregnancy

  - absolute requirements

  - complications of systemic treatment

  - medical treatment by direct injection

  - multidose treatment regimen

  - preferred characteristics

  - results of

  - side effects of

  - single-dose regimen

  - symptoms of pain

  - tubal rupture

Metrorrhagia, definition

MHP (mental health provider)

Microadenomas

Microrna (miRNA) expression

Midnight serum cortisol concentration

Mifepristone (RU 486)

- abortion

- emergency postcoital contraception

Migraine headaches

- evaluation

- management of

- by eliminating the menstrual cycle
- estrogen and
- oral contraception
- pathophysiology
- treatment

Million Women Study

Minilaparotomy

Minoxidil, hirsutism

Mirena

Miscarriage, 979. See also Early pregnancy loss

- clomiphene citrate

- spontaneous miscarriage

  - oral contraception

- spontaneous miscarriage leiomyomas

Misoprostol

Mitosis

Mitral valve prolapse, oral contraception

Mixed gonadal dysgenesis

MMPs (matrix metalloproteinases)

Möbius's syndrome

Molecular biology techniques

- ChIP

- cloning DNA

- DNA microarrays

- DNA sequencing

- genomics, proteomics and omics revolution

- hybridization

- polymerase chain reaction

- Southern blot analysis

- transgenic animals

Monocyte chemotactic protein-1

Morbidity, compression

Morning after treatment. See Emergency postcoital contraception

Mosaicism

- amenorrhea and

- gonadectomy and

mRNA genetic code

Müllerian agenesis  
    amenorrhea and  
    incidence of  
Müllerian anomalies, classification  
Müllerian renal cervicothoracic somite dysplasia (MURCS association)  
Müllerian system  
    classification of anomalies  
    defects of  
    development of  
Müllerian-inhibiting substance, 72. See also Anti-müllerian hormone (AMH)  
Multiload-375  
Multiple sclerosis, oral contraception  
Mumps orchitis  
Mutation  
Myocardial infarction  
    incidence of in reproductive age women  
    oral contraception  
Myomectomy  
Myometrial responses, human parturition

## **N**

Naloxone  
National Center for Biotechnology Information (NCBI)  
National Survey of Family Growth (NSFG)  
Natural killer (NK) cells  
NCBI (National Center for Biotechnology Information)  
Neovascularization, promotion of  
Nerve growth factor (NGF)  
Neurohormone  
Neuropeptide Y (NPY)  
Neurophysins  
Neurotrophins  
Next-generation sequencing (NGS)  
NGF (nerve growth factor)  
NGS (next-generation sequencing)  
NHEJ (nonhomologous end joining)  
Nicotine neurophysin

Nitric oxide  
NK (natural killer) cells  
Nomenclature, hormones  
Nonhomologous end joining (NHEJ)  
Nonsteroidal anti-inflammatory drugs (NSAIDs)  
Noonan syndrome  
Norepinephrine tract  
Norethindrone  
Norethindrone acetate  
Norethindrone enanthate  
Norethindrone family  
Norethynodrel  
Norgestimate  
Norgestrel  
Normal menses  
Normal reproductive efficiency  
Normal sexual differentiation  
    central nervous system  
    external genitalia  
    genetics  
    genital duct development  
        mesonephric (wolffian)  
        paramesonephric (müllerian)  
    germ cell  
    ovary  
    testis  
Norplant, 917. See also Implant systems  
Northern blotting  
NSAIDs (nonsteroidal anti-inflammatory drugs)  
NSFG (National Survey of Family Growth)  
Nuclear receptor superfamily  
Nucleocytoplasmic shuttling  
Nucleolar channel system  
Numerical abnormalities

## **O**

Obesity. See also Weight

anatomic  
android  
best diet  
CNS and cardiovascular side effects  
commercial programs  
definition of  
drugs for weight loss  
endocrine changes with  
fluoxetine  
frequency of, with anovulation  
gynoid  
ideal weight  
inherited aspects of  
insulin resistance  
leptin  
long-term therapy  
management of  
metabolic syndrome  
Nurses' Health Study  
Ob gene  
oral contraception  
orlistat  
prevalence of  
rodent models of  
smoking cessation  
thyroid hormone  
waist circumference  
waist/hip ratio  
weight loss, difficult to maintain  
Obstructive sleep apnea  
Off-label uses of steroid contraception  
OGTT (oral glucose tolerance test)  
OI (ovulation induction)  
Oligomenorrhea  
    in adolescence  
    definition  
    moderate hyperprolactinemia

OMI (oocyte maturation inhibitor)

Omics revolution

Onapristone

Oocyte maturation inhibitor (OMI)

Oocyte retrieval. See also in vitro fertilization

Oocytes

- cryopreservation

- exerts control over granulosa functions

- gap junctions

- increasing prevalence of aneuploidy in aging oocytes

- maturation

- meiosis

- meiotic divisions of

- number of

Oogonia

- fetal life

- maximum content

- primordial germ cells

Open reading frame

Opiates

- clinical implications

- endogenous

  - runners' high

- $\beta$ -endorphin

- peptides and menstrual cycle

Opioid peptides

Oral contraception

- abnormal uterine bleeding and

- absolute contraindications to the use of

- acetaminophen

- acne

- adrenal gland

- alternative route of administration

- amenorrhea

- anovulation

- anovulatory bleeding and

- arterial thrombosis

aspirin  
athletes  
avoiding menstrual bleeding  
bacterial vaginosis  
benign breast disease  
breakthrough bleeding  
breast cancer  
    effect on  
breast discomfort  
breastfeeding  
carbohydrate metabolism  
cardiac anomalies  
cardiovascular disease  
    coagulation system  
cervical cancer  
chickenpox  
chlamydial infections  
chloasma  
chlordiazepoxide  
choice of pill  
cholestatic jaundice  
clinical recommendation  
colorectal cancer  
compliance (continuation)  
congenital heart disease  
congenital malformations  
continuous dosing  
desogestrel  
diabetes mellitus  
diazepam (Valium)  
drospirenone 968  
eating disorders  
efficacy  
    drugs that affect  
elective surgery  
endometrial cancer  
endometriosis, protect against

estrogenic approach (Estronstep)  
ethinyl estradiol  
extended regimens  
    clinical studies  
eye and ear diseases  
factor V Leiden mutation  
    carrier frequencies of the Leiden mutation  
failure of  
former smoker  
gallbladder disease  
generic products  
gestational diabetes  
gestodene  
gonococcal disease  
healthy user effect  
hematologic effects  
hemoglobin A1c  
hemorrhagic disorders  
hepatic disease  
hirsutism  
    treatment and  
history  
hypercoagulability  
hyperlipidemia  
hypertension  
    pregnancy-induced  
inadvertent use during conception pregnancy  
infectious mononucleosis  
inflammatory bowel disease  
initiation of, postpartum period  
insulin resistance  
insulin sensitivity  
laboratory surveillance  
liver  
    acute or chronic cholestatic liver disease  
    gallstones  
liver adenoma



liver cancer  
mechanism of action  
medroxyprogesterone acetate  
melanoma  
mental depression  
mestranol  
migraine headaches  
mitral valve prolapse  
molar pregnancy  
multiphasic preparation  
multiple sclerosis  
myocardial infarction  
    incidence of in reproductive age women  
nausea  
noncontraceptive benefits  
norethindrone family  
norgestimate  
norgestrel  
19-nortestosterones  
obesity  
obstructive jaundice in pregnancy  
off-label uses of steroid contraception  
for older women  
organ transplantation  
ovarian cancer  
ovarian cysts  
pill taking  
    immediate start  
    postpone a menstrual period  
    Sunday start  
polycystic ovaries  
porphyria  
postpill amenorrhea  
potency  
preferential prescription  
premenstrual dysphoric disorder (PMDD)  
premenstrual syndrome

progesterone breakthrough bleeding  
progestin component  
prolactin-secreting adenomas  
prothrombin mutation  
puberty, use during  
relative contraindications requiring clinical judgment and informed consent  
reproduction after  
    delay in achieving pregnancy  
    fertility  
    pregnancy outcome  
    spontaneous miscarriage  
rheumatoid arthritis  
seizure disorders  
sickle cell disease  
smoking  
stroke  
    incidence of in reproductive age women  
systemic lupus erythematosus  
theophylline  
thrombophilia screening  
thyroid gland  
transdermal estrogen-progestin contraception  
for transition years  
Trichomonas  
tricyclic antidepressants  
urinary tract infections  
uterine leiomyoma  
VACTERL complex  
vaginal administration  
vaginal estrogen-progestin contraception  
valvular heart disease  
venous thromboembolism and  
    relative risk and actual incidence of  
    screening for inherited disorders  
voice changes  
weight gain  
what to do when pills are missed

when to change to postmenopausal hormone therapy

Yasmin

Yaz

Oral glucose tolerance test (OGTT)

Orchiopexy

Organ transplantation

gonadotropin-releasing hormone agonist

oral contraception

Orlistat

Orphan receptors

Orthotopic transplantation

Osteoarthritis

estrogen therapy and

incidence

Osteopenia

biochemical markers of bone turnover

bone mineral density

Osteoporosis

acquiring bone mass

alcohol consumption, excessive and

alternative therapies, preventing bone loss

equol

ipriflavone

phytoestrogens

antifracture treatment

bisphosphonates and

alendronate (Fosamax)

atrial fibrillation

and esophageal cancer

jaw osteonecrosis

pain

risedronate (Actonel)

zoledronic acid

bone density

gain in

low, and increase in fracture risk

measuring

reasons to measure  
bone mass, changes with age  
bone metabolism and estrogen  
bone mineral density values  
bone-losing medications  
calcitonin and  
calcium supplementation and  
cigarette smoking  
definition of  
denosumab  
diagnostic tests  
estrogen and  
    agonists-antagonists  
    amount of  
    assessing blood levels of  
    levels in older women and  
excessive thyroxine  
fluoride  
follow-up assessment of hormone-treated women  
fractures and  
growth hormone  
lifestyle modifications  
management of nonresponder  
menopausal hormone treatment for  
    fracture outcomes  
onset of bone loss  
pathophysiology  
physical activity and  
progestational agents and  
proton pump-inhibiting drugs  
racial differences  
risk of fracture from  
selective estrogen agonists/antagonists (selective estrogen receptor modulators)  
signs and symptoms of  
    Colles' fracture  
    head of femur fracture  
    risk factors for fractures

spinal (vertebral) compression fracture

tooth loss

starting treatment later in life

statins

strontium

T Score

teriparatide (Forteo)

thiazides diuretics

thiazolidinediones

tibolone

Vitamin D and

Z score

Osterix (Osx)

Ota rings

Ovarian androgen-secreting tumors

Ovarian antibodies

Ovarian cancer

breast

oral contraception

sterilization

Ovarian conditions, local

Ovarian cysts

implant systems of contraception and

oral contraception

Ovarian follicles

Ovarian function

bioassays of estrogen production

chronic anovulation

general management

hyperprolactinemia

thyroid disorders

ovarian failure and insufficiency

autoimmune screening

fragile X (FMR1) premutations

karyotype

serum AMH concentration

serum estradiol concentration

- serum FSH concentration
- Ovarian hyperstimulation syndrome
  - FSH secreting adenomas
  - gonadotropins
- Ovarian pregnancy
- Ovarian remnant syndrome
- Ovarian reserve and its assessment
  - antimüllerian hormone
  - antral follicle count
  - basal FSH and estradiol concentrations
  - clomiphene citrate challenge test
  - combined tests
  - defined
  - inhibin B
  - number of responsive follicles
  - ovarian volume
- Ovarian reserve tests
  - prognosis for an abnormal ovarian reserve test
- Ovarian stimulation regimen, 1009. See also In vitro fertilization
- Ovarian stromal hyperthecosis
- Ovarian tissue cryopreservation
  - combination of ovarian tissue with assisted reproductive technologies
  - freezing techniques
  - menopause and premature ovarian failure
  - potential complications
  - transplantation locations
  - in vitro follicle maturation
  - whole ovary
- Ovarian tissue freezing techniques
- Ovarian tumors
- Ovarian volume
- Ovary. See also Egg
  - adult
  - 3 $\beta$ -hydroxysteroid dehydrogenase deficiency
  - childhood
  - corpus luteum
  - disorders

fetal  
follicle formation  
follicular development  
follicular growth  
human  
indifferent gonad stage  
modulators of function  
neonatal  
oocyte formation  
oogonial multiplication  
origin of the gonadal somatic cells  
ovarian actions of IGFs  
ovarian failure  
ovulation  
oxytocin and  
primordial germ cells  
stage of differentiation  
steroidogenesis

Overnight dexamethasone suppression test

Overweight

Ovotesticular disorder of sexual development

Ovulation

brain and

induction

clomiphene citrate

inhibition

proteolytic enzymes and

timing

Ovulation induction (OI)

Ovulation prediction kits

Ovulatory dysfunction

assessment of ovulation

basal body temperature

endometrial biopsy

luteal phase deficiency

menstrual history

serum progesterone concentration

transvaginal ultrasonography  
urinary LH excretion

Ovum

for fertilization  
time spent transporting through tube  
transvaginal endoscopic observation  
tubal factor infertility

Oxytocin

human parturition  
in response to suckling

## **P**

P450 oxidoreductase deficiency

Pachytene

PAI-1

Pancreatitis

estrogen therapy and  
severe hypertriglyceridemia  
triglyceride response and

Panhypopituitarism

Paracrine communication

ParaGard

Paramesonephric ducts

Paroxetine (Paxil)

Parturition

endocrinology of  
human parturition  
induced abortion  
labor and cervical ripening, induction of  
prostaglandin inhibition, treatment of  
prostaglandins and postpartum hemorrhage  
prostaglandin role in

P450c17

upregulation

PDGF (platelet-derived growth factor)

Pearl Index

Pelvic inflammatory disease (PID)



IUDs and  
oral contraception

Penetrance

Percutaneous epididymal sperm aspiration (PESA)

Pergolide

Perimenopausal transition

abnormal uterine bleeding

age of onset for 95% of women

atrophic changes

average age of onset

average duration

bone loss during See also (Osteoporosis)

cognition and dementia

definition of

emotional stability during

estradiol levels

FSH levels

hormone levels, circulating

mental health

mood problems

preventive health screening of

quality of life during

sleep patterns during

symptomatology

vasomotor symptoms

Peripheral signaling

candidate metabolic signals

leptin

Permanent hair removal

Perrault syndrome

Persistent mullerian duct syndrome (PMDS)

Persistent surgical treatment

Personal genomics

PESA (percutaneous epididymal sperm aspiration)

Petrosal venous sinus catheterization

PH-20 (SPAM1)

PH-30 (fertilin)

Phantom hCG

Pheromones

Phosphatidylcholine

Physiologic feedback loop

Physiologic transplantation

Phytoestrogens

- bone loss prevention

- breast and

- cardiovascular disease

- cognition and

- effect on lipids

- isoflavone

- summary of clinical effects

PID (pelvic inflammatory disease)

- IUDs and

- oral contraception

Pincus, Gregory

Pineal gland

- hyperplastic pineal tumors

- possible roles in humans

Pinopodes

Pit-1 protein

Pituitary

- action of progesterone on

- activin

- anterior blood supply of

- follicle-stimulating hormone

- gonadotrope

- gonadotropin secretion

- inhibin

- oxytocin

- posterior pathway

- prolactin, secretion of

- response to GnRH

Pituitary adenomas

Pituitary function tests

Pituitary incidentaloma

Pituitary MRI

Pituitary prolactin-secreting adenomas  
oral contraception

Pituitary tumors

Placental corticotrophin-releasing hormone

Placental gonadotropin-releasing hormone

Placental growth hormone-releasing hormone

Placental hormones

Placental sulfatase deficiency

Placental thyrotropin-releasing hormone

Placental villus

Placentation  
implantation and

Plasmin

Plasminogen

Plasminogen activator inhibitor-1 (PAI-1)

Platelet-derived growth factor (PDGF)

Plummer's disease (toxic nodular goiter)

PMDS (persistent Mullerian Duct Syndrome)

Pneumothorax  
catamenial

Polycystic ovary  
estradiol levels and  
estrogen levels and  
free testosterone  
genetic considerations  
hyperandrogenism and  
hyperinsulinemia and  
hyperthecosis  
insulin resistance and  
LH/FSH ratio  
metabolic abnormalities  
obesity  
ovarian drilling  
plasminogen activator inhibitor type-1 (PAI-1)  
use of ultrasonography and  
wedge resection, success of

## Polycystic ovary syndrome (PCOS)

abnormal gonadotropin secretion

adolescent with

cancer risk

clinical management

alopecia

hirsutism

infertility

lifestyle modification

menstrual abnormalities and endometrial cancer

metabolic abnormalities and health risks

metformin

diagnosis

clinical hyperandrogenism

hyperandrogenemia

ovulatory and menstrual dysfunction

polycystic ovaries

disorders, exclusion of

androgen-secreting ovarian and adrenal tumors

congenital adrenal hyperplasia

Cushing syndrome

hyperprolactinemia

idiopathic hirsutism

insulin resistance syndromes

thyroid disorders

dyslipidemia

early pregnancy loss

inflammation

insulin resistance

obesity

pathophysiology

androgen synthesis and action

genetic considerations

gonadotropin secretion and action

insulin secretion and action

obesity

weight and energy regulation

and psychological well-being  
reproductive aging and menopause

Polygenic traits and disorders

Polymenorrhea

definition

Polymerase chain reaction

Polymorphisms

Polyploidy

Pomeroy method

Population

change in female demographics

growth of older population

men per 100 US women

older U.S. female population

percent elderly in US population

world

world population changes

Porphyria

oral contraception

Post abortion contraception

Postcoital test

Postejaculatory urinalysis

Posterior pituitary pathway

Postmenopausal hormone therapy. See also Menopausal hormone therapy

acetylcholine

allopregnanolone

AndroGel

androgens

beneficial effects

unwanted effects

bazedoxifene

breast cancer and

breast discomfort

cardiovascular disease

ACE and renin level reduction

actions on heart and large blood vessels

adhesion molecules reduction

clinical trials  
C-reactive protein (CRP)  
direct antiatherosclerotic effects  
endothelial cell protection  
endothelium-dependent vasodilation and antiplatelet aggregation  
endothelium-independent vasodilation  
fibrinolysis  
glucose metabolism  
high-density lipoprotein (HDL) levels and  
homocysteine  
hypertension  
inhibition of lipoprotein oxidation  
intimal thickening inhibition  
lipids and lipoproteins  
lipoprotein  
macrophage foam cell formation inhibition  
metabolic syndrome  
observational studies  
optimal cholesterol/lipoprotein profile  
reduction of homocysteine  
sex steroids  
tibolone, effect on  
triglycerides

Women's Health Initiative (WHI), evidence from  
cervical cancer  
clinical approach  
composition of conjugated estrogens  
dehydroepiandrosterone  
equol  
estradiol  
estriol  
estrogen  
estradiol implants  
estradiol levels, oral vs. transdermal estrogen  
estring  
FSH levels and monitoring dosage  
monitoring dosage with estradiol blood levels

- oral administration
- transdermal administration
- vagifem
- vaginal administration of, low-dose method
- vaginal administration of, standard dose method
- history of
- hot flushes, treatment options
- hyperinsulinemia and
- hysterectomized women and
- intrauterine device
- ipriflavone
- isoflavones
- levonorgestrel IUS
- medroxyprogesterone acetate
- methyltestosterone
- nitric oxide and
- ospemifene
- pregnanolone
- progestational side effects
- progesterone
  - transdermal
- progestins available worldwide
- raloxifene
- relative estrogen potencies
- selective estrogen receptor modulators
- sequential and continuous regimens
- systemic effects
  - activated protein C resistance
  - carbohydrate metabolism
  - clotting factors
  - inflammatory markers
  - lipids and hepatic enzymes
  - metabolic syndrome
  - myocardial infarction risk
  - skeleton
  - smokers, effects
  - VTE risk

transdermal estrogen-progestin combinations

vaginal gel

vasomotor symptoms

when to change from estrogen-progestin contraception to

Postmenopause, hormone profile

Postpartum hemorrhage

acute infarction and ischemic necrosis, pituitary gland

endocrinology, of parturition

pituitary infarct

Postpartum risk

contraception

pregnancy

venous thromboembolism

Postpartum thyroiditis

Postpartum venous thromboembolism

Potocytosis

Preantral follicle

Precocious puberty

classification

diagnosis of

endocrine evaluation and imaging

GnRH-dependent

GnRH-independent

idiopathic

incomplete precocious puberty

McCune-Albright syndrome

ovarian follicular

premature adrenarche

premature thelarche

treatment of, GnRH agonist

Pregabalin (Lyrica)

Pregnancy

fetal lung maturation

hyperthyroidism

hypothyroidism

inadvertent use during the conception pregnancy

and lactation



molar, oral contraception

of parturition

human parturition

induced abortion

labor and cervical ripening, induction of  
prostaglandin inhibition, treatment of  
prostaglandins and postpartum hemorrhage

postpartum period

postpartum risk

prostaglandins

biosynthesis

inhibition

metabolism

thromboxane and prostacyclin

protein hormones of

$\alpha$ -fetoprotein

atrial natriuretic peptide

cytokines and growth factors

endogenous opiates

false-positive tests /Phantom hCG

growth hormone, growth hormone–releasing hormone and somatostatin

human chorionic adrenocorticotropin

human chorionic gonadotropin

human chorionic thyrotropin

human placental lactogen

hypothalamic-like releasing hormones

inhibin, activin and follistatin

pregnancy-specific  $\gamma$ 1-glycoprotein

prolactin

relaxin

renin-angiotensin system

steroid hormones in

estrogens

fetal adrenal cortex

placental sulfatase deficiency

progesterone

thyroid gland

maternal thyroid hormones

Pregnancy luteoma

Pregnancy-associated plasma protein A

Pregnancy-specific  $\gamma$ 1-glycoprotein (PSG)

Pregnane nucleus

Preimplantation genetic diagnosis (PGD)

comparative genome hybridization

detection of single gene disorders

fluorescence in situ hybridization (FISH)

Preimplantation genetic testing

for aneuploidy

array comparative genomic hybridization (aCGH)

equipment and techniques

fluorescence in situ hybridization (FISH)

for monogenic disorders

next-generation sequencing (NGS)

quantitative PCR (qPCR)

single nucleotide polymorphisms (SNPs)

timing of biopsy

Preimplantation genetic testing for monogenic disorders (PGT-M)

Preimplantation signaling

Premature adrenarche

Premature ovarian failure (POF)

autoimmune disorders

chemotherapy

follicular development

fragile X (FMR1) premutations

galactosemia

management

fertility

hormone therapy

psychological and emotional support

numerical and structural chromosomal abnormalities

radiation therapy

Premature ovarian insufficiency (POI)

Premature thelarche

Premenstrual asthma

Premenstrual dysphoric disorder

Premenstrual syndrome

alprazolam

American Psychiatric Association, guidelines for diagnosis

asthma, premenstrual

calcium supplementation and

choice of treatment

danazol

definition of

diagnostic criteria

drospirenone

etiologies

evening primrose oil

exercise and relaxation techniques

fluoxetine

GnRH agonist treatment

historical myths

medical oophorectomy by GnRH

medroxyprogesterone acetate

migraine headaches

National Institute of Mental Health (NIMH) guidelines for diagnosis

oophorectomy and

oral contraceptives and

pathophysiology

placebo response

prevalence of

progesterone treatment

selective serotonin reuptake inhibitor

social consequences of

spironolactone

thyroid function and

treatment

vitamin B6 and

Premenstrual syndrome/premenstrual dysphoric disorder (PMDD)

Preovulatory follicle

Presacral neurectomy (PSN)

Primary ciliary dyskinesia

Primary follicle

Primary gonadal disorders

causes of

cryptorchidism

Klinefelter syndrome

single gene mutations and polymorphisms

varicoceles

Y chromosome deletions

Primary ovarian insufficiency (POI)

Primordial follicle

growth and atresia of

Primordial germ cells

Prodynorphin

Proenkephalin A and B

Progesterone

action in hypothalamus and pituitary

affects the positive feedback response to estrogen

endogenous, breast cancer and

levels, menstrual cycle

metabolism

premenstrual syndrome treatment for

receptor

receptor expression

receptors

steroid hormone, pregnancy

transdermal

Progesterone receptors (PR)

receptor-A

receptor-B

Progestins

actions on the endometrium

anovulatory bleeding, treatment

effect of, combined regimens

hyperplasia, therapy for

oral contraception component

Prokaryotes

Prolactin

in amniotic fluid  
concentrations  
decidua, synthesis of  
dopaminergic mechanism  
elevated levels and amenorrhea  
function  
gene expression  
heterogeneity of  
homeostasis  
inhibiting dopamine  
Pit-1 protein  
prolactin receptor  
prolactin-releasing factor  
secretion  
transcription of the gene  
Prolactin-inhibiting hormone  
Prolactinomas  
Prolactin-secreting adenomas  
oral contraception  
pituitary  
Proliferative phase  
Promensil  
Promoter  
Proopiomelanocortin (POMC)  
Prophase  
Prorenin  
Prostacyclin  
Prostaglandin E2 (PGE2)  
Prostaglandin F2 $\alpha$  (PGF2 $\alpha$ ), dysmenorrhea  
Prostaglandins  
Prostaglandins (PG)  
abortion  
biosynthesis  
endocrinology, pregnancy  
biosynthesis  
inhibition  
metabolism

thromboxane and prostacyclin  
in endometrium  
and fetal breathing  
and fetal circulation  
inhibition

of parturition  
metabolism  
in parturition  
and postpartum hemorrhage  
thromboxane and prostacyclin

Prostate screening

Protectaid sponge

Protein hormones

of pregnancy

$\alpha$ -fetoprotein

atrial natriuretic peptide

cytokines and growth factors

endogenous opiates

false-positive tests /Phantom hCG

growth hormone, growth hormone–releasing hormone and somatostatin

human chorionic adrenocorticotropin

human chorionic gonadotropin

human chorionic thyrotropin

human placental lactogen

hypothalamic-like releasing hormones

inhibin, activin and follistatin

pregnancy-specific  $\gamma$ 1-glycoprotein

prolactin

relaxin

renin-angiotensin system

Proteins

Proteome

Proteomics

Proximal tubal obstruction

Psychological well-being, PCOS

Puberty

adrenarche

age of menarche  
blood hormone concentrations during, female  
decline in the age of menarche  
delayed  
    relative frequency of abnormalities  
endocrinology of  
growth  
induction and suppression strategies, transgender endocrinology  
leptin  
oral contraception  
precocious  
stages of development  
timing of  
    summary of events

Puberty induction and suppression strategies, in transgender endocrinology

## **Q**

Quantitative PCR (qPCR)

## **R**

Radiation  
Raloxifene  
Real-time PCR  
Receptor-mediated endocytosis  
Receptors  
    androgen  
    breast cancer, clinical prognosis  
    estrogen  
    G protein  
    insulin-like growth factors (IGF)  
    kinase  
    leptin  
    ligand-cell membrane extranuclear activity  
    progesterone  
    receptor superfamily  
    role of in early follicular development  
    thyroid hormone

Recombinant DNA technology  
Rectangularization of life  
Recurrent ovarian torsion  
Red clover  
Regulated on activation, normal T cell expressed and secreted (RANTES)  
Regulatory domain  
Reifenstein syndrome  
Relaxin  
Renal ultrasonography, infertility  
Renin-angiotensin system  
Replication  
Reproductive aging  
    early menopausal transition (STRAW Stage 2)  
    early postmenopause  
    late menopausal transition (STRAW Stage 1)  
    late postmenopause  
    late reproductive stage (STRAW Stage 3)  
    and menopause  
    stages of  
Resistant ovary syndrome  
Restriction enzyme  
Restriction fragment length polymorphisms  
Rete ovarii  
Retrograde ejaculation  
Reverse T3 (RT3)  
Reverse transcriptase  
Reverse transcription PCR  
Rheumatoid arthritis  
    oral contraception  
RNA splicing  
Rotterdam criteria  
Rspo1 expression  
Rubella immunity, screen for  
Runner's "high," 383

## **S**

Saf-T-Coil



Saline sonohysterography

Salpingitis isthmica nodosa (SIN)

Scalp hair thinning

Schizophrenia

Scrotal temperature

Secretory phase

Seizure disorders, oral contraception

Seizures

- catamenial

- oral contraception

Selectins

Selective estrogen receptor modulators (SERMs)

Selective ovarian venous catheterization

Selective progesterone receptor modulators (SPRMs)

Sella turcica

- elevated prolactin level

- galactorrhea and

Semen

- analysis

  - concentration of sperm

  - ejaculate volume and

  - leukocytospermia

  - lower reference limits

  - morphology of sperm

  - motility of sperm

  - pH and

  - round cells and

  - total sperm count

  - viscosity

- normal reference values

- pH of

Septate uterus

Sertoli cells

Sertraline (Zoloft)

Serum 17 $\alpha$ -hydroxyprogesterone concentration

Serum progesterone concentration

Sex hormone-binding globulin (SHBG)

Sex steroids

- androstane nucleus

- cardiovascular disease

- classes of

- estrane nucleus

- pregnane nucleus

- receptors

Sexual hair

Sexuality

- illness

- menopause

- sterilization

Sexually transmitted infections (STIs)

- bacterial and oral contraception

- barrier method of contraception and protection against

- viral and oral contraception

Sheehan syndrome

Short feedback loop

Short stature

- evaluation

- idiopathic

- treatment of

Short-acting antagonists

Sibutramine

Sickle cell disease

- infertility

- oral contraception

Silastic (Falope or Yoon) ring

SIN (salpingitis isthmica nodosa)

Single gene mutations

Single nucleotide polymorphisms (SNPs)

Single-gene sequence variation

SLE (systemic lupus erythematosus)

Sleep apnea

- hormone therapy implications for women

- testosterone treatment

Slow-freezing method

Smokers, physician

Smoking, oral contraception

Soluble endoglin (sENG)

Soluble fms-like tyrosine kinase (sFlt-1)

Somatostatin

Somatotroph adenomas

Sonohysterography

Sonohysterosalpingography

Southern blot analysis

SOX9

Sperm. See also Semen

- acrosin

- acrosomal membrane

- agglutination

- antisperm antibodies

- attrition

  - from vagina to tube

- autoantibodies

- capacitation

- chromatin structure and infertility

- donor

  - guidelines established by the American Society for Reproductive Medicine

  - quality of frozen specimens

- fertilizable lifespan of

- flagellum

- function tests

  - acrosome reaction

  - biochemical tests

  - chromatin structure

  - computer-assisted sperm analysis

  - DNA

  - human zona binding assay

  - penetration assay

- hyperactivated motility

- leukocytospermia

- penetration assay

- pH-20

pH-30

requirements for the maintenance of spermatogenesis

retrieval

round cells

strict criteria

testicular sperm extraction and aspiration

transport

ZP3, primary ligand for

Sperm autoantibodies

Sperm penetration assay

Sperm retrieval

Spermatogenesis

Sperm-egg fusion

Spermicides

efficacy

protection against sexually transmitted infections

side effects

allergy

vaginal postcoital douches

Sperm-mucus interaction abnormalities

Spinnbarkeit

Spirolactone

hirsutism and

premenstrual syndrome

Sponge contraceptive

Protectaid

Today

SPRY2

SRY (sex-determining region on the Y chromosome)

St. John's wort

alternative therapies

depression

Stages of Reproductive Aging Workshop (STRAW)

early menopausal transition (STRAW Stage 2)

early postmenopause

late menopausal transition (STRAW Stage 1)

late postmenopause

late reproductive stage (STRAW Stage 3)

Start codon

Sterilization

bipolar method

ectopic pregnancy

efficacy of

electrosurgical methods

failure rates

female methods, failure rates

and fertility

Filshie clip

history

Hulka-Clemens spring clip

Irving method

male methods

menstruation

minilaparotomy

monopolar electrosurgery

ovarian cancer

Pomeroy method

reversibility

sexuality

silastic (Falope or Yoon) ring

techniques, female

transcervical approach

Uchida method

vaginal approach

vasectomy

prostate cancer

reversal

Steroid acute regulatory (StAR) protein deficiency

Steroid add-back, GnRH

Steroid 5 $\alpha$ -reductase deficiency

Steroid biosynthetic pathway

Steroid contraception

Steroid hormones

in pregnancy

estrogens  
fetal adrenal cortex  
placental sulfatase deficiency  
progesterone

Steroid sulfatase (STS)

Steroidogenesis

of corpus luteum  
dehydrogenase reactions  
dehydrogenases reaction  
desmolase reaction  
hydroxylation reaction  
ovarian  
receptors involved in  
saturation

Steroidogenic acute regulatory (StAR) protein

Steroidogenic factor-1 (SF-1)

Steroids

blood production rates  
blood transport of  
excretion

Sterol carrier protein 2 (SCP2)

Stop codon

Stratum compactum

Stratum spongiosum

Stress related endocrine perturbations

Stroke

incidence of in reproductive age women  
oral contraception

Stromal cell–derived factor 1 (SDF1)

Strontium

Structural abnormalities

Structural determinants, gender identity

Study of Women’s Health Across the Nation (SWAN)

menopause

Subclinical hypothyroidism

Submucous myomas

Sulfo conjugates

Sulindac

SWAN (Study of Women's Health Across the Nation)

menopause

Swim-up method

Swyer's syndrome

Systemic lupus erythematosus (SLE)

## T

Tall stature

treatment of

Tamoxifen

antiestrogen

breast cancer

adjuvant therapy and

prevention trials

breast cancer treatment

endometriosis and

estrogenic activity of

gynecologic problems

hot flushing

levonorgestrel-releasing intrauterine device (IUD) and

mechanism of action

prophylaxis for carcinoma in situ

risks associated with

with saline instillation sonohysterography

Tandem repeat sequences

Tanner staging

Tanycytes

TCu-380A

Teleologic theory, endometrium

Telogen

Telogen effluvium

Telophase

Terminal hair

TESE (testicular sperm extraction and aspiration)

Testes

SRY, the sex-determining region on the Y chromosome

- testosterone synthesis
- Testes-determining factor (TDF)
- Testicular function regulation
  - hormone regulation
  - spermatogenesis
- Testicular regression syndrome
- Testicular sperm extraction and aspiration
- Testis biopsy, infertility
- Testosterone
  - assays
    - free testosterone
  - hirsutism and
  - levels of menopausal transition
  - synthesis in testes, fetal
- Theca lutein cysts (hyperreactio luteinalis)
- Thelarche
  - mean age of
  - premature
- Thermolytic techniques
- Thrombophilias
  - early pregnancy loss
    - indications for screening
  - prevalence of in women with recurrent pregnancy loss
- Thromboxane (TX)
- Thyroid
  - fetal thyroid hormones
  - fine-needle aspiration
  - function tests
  - newborn thyroid hormones
  - nodules
  - physiology in fetus and the neonate
  - physiology of, normal
  - pregnancy
    - maternal thyroid hormones
    - postpartum thyroiditis
  - premenstrual syndrome and
  - receptor



risk factors for thyroid cancer

Thyroid function tests

free thyroxine (FT4)

free thyroxine index (FTI/T7)

laboratory evaluation

radioactive iodine uptake

thyroglobulin (Tg) autoantibodies

thyroid peroxidase (TPO)

thyroid-stimulating hormone (TSH)

total T3 and reverse T3

total thyroxine (TT4)

TSH-receptor

Thyroid gland, oral contraception

Thyrotoxicosis

Thyrotroph adenomas

Thyrotropin-releasing hormone (TRH)

Thyroxine (T4)

excessive, and osteoporosis

free thyroxine (FT4)

free thyroxine index (FTI or T7)

radioactive iodine uptake

thyroid-stimulating hormone (TSH)

total thyroxine (TT4)

Thyroxine-binding globulin (TBG)

Tibolone

androgen metabolism to estrogens

bone, effect on

breast, effect on

cardiovascular system, effect on

chemistry

diabetes, effect on

endometrium, effect on

breakthrough bleeding rates

hot flushing and

increase in libido

menopausal symptoms, effect on

sexuality

- uterus, effect on
- vaginal dryness
- Timing hypothesis
  - primary prevention randomized clinical trials
- Tissue factor (TF)
- Tissue-selective estrogen complex
- TNF- $\alpha$  (tumor necrosis factor- $\alpha$ )
- Tocolytic therapy
- Tranexamic acid
- Transcervical approach, sterilization
- Transcortin
- Transcription
- Transdermal estrogenprogestin contraception
- Transdermal method
- Transdermal progesterone
- Transformation/activation
- Transforming growth factor (TGF)
- Transgender (TG) endocrinology
  - biologic determinants
  - gender-affirming hormone therapy
    - in adolescents
    - in adults
  - health and wellness
  - health insurance programs
  - multidisciplinary team approach
  - nomenclature
  - prevalence
- Transgenic animals
- Translation
- Translocation
- Transrectal ultrasonography
  - infertility, male
  - uterosacral ligaments/rectovaginal septum
- Transscrotal ultrasonography, male infertility
- Transsphenoidal surgery
- Transurethral resection of ejaculatory ducts
- Transvaginal ultrasonography

- ectopic pregnancy
- Transverse vaginal septum
- Trichomonas
  - oral contraception
- Triglycerides
  - cardiovascular disease
  - oral therapy
  - severe hypertriglyceridemia and pancreatitis
- Trophectoderm biopsies
- Trophoblast
- Tropic hormones
  - heterogeneity
  - mechanism of action
  - regulation of
- True hermaphrodite
- Tryptophan
- Tubal occlusion and adnexal adhesions
  - chlamydia antibody tests
  - hysterosalpingo-contrast sonography
  - hysterosalpingography (HSG)
    - advantages and disadvantages of oil and water-soluble contrast media
    - basic technique for performing
  - laparoscopy
  - sonohysterosalpingography
  - tubal surgery
    - distal tubal obstruction
    - prognosis for successful pregnancy after microsurgical sterilization
    - proximal tubal obstruction
- Tumor necrosis factor- $\alpha$  (TNF- $\alpha$ )
- Turner syndrome
  - amenorrhea and
- Two-cell system

## U

- Uchida method
- Ultrashort feedback
- Unicornuate uterus

Unilateral oophorectomy

Uniplant

Up-regulation of receptors

Urinary LH excretion

Urinary tract infections

diaphragm

oral contraception

Urine

pregnanediol glucuronide

pregnant women with indomethacin

Uterine artery embolization (UAE)

ectopic pregnancy

Uterine leiomyomas (fibroids)

hormone treatment

oral contraception

Uterine myomas

Uterine spiral arterioles

Uterodomes

Uteroglobin

Uterus

aging effect on

anatomical abnormalities of

distribution of specific anomalies

müllerian defects, incidence of

arcuate uterus

bicornuate uterus

double uterus

imaging, abnormal uterine bleeding

intrauterine adhesions (Asherman's Syndrome)

isolated agenesis of the cervix

septate uterus

uterus didelphus

vasculature of

Uterus didelphus (double uterus)

## V

Vagifem, systematic absorption of estrogen

Vaginal approach, sterilization  
Vaginal dilation  
    Frank, described  
Vaginal estrogen-progestin contraception  
Vaginal outflow tract obstruction  
Vaginal postcoital douches  
Vaginal ring method  
van Leeuwenhoek, Anton  
Varicella (chicken pox), screen for  
Varicocele  
    repair  
Variomics  
Vascular endothelial growth factor (VEGF)  
Vasectomy  
    ectopic pregnancy  
    prostate cancer  
    reversal  
Vasopididymostomy  
Vasopressin  
Vasovagal syncope (VVS)  
Vasovasostomy  
    pregnancy rates after 1288  
Vellus hair  
Venlafaxine (Effexor)  
Venous thromboembolism and  
    emergency postcoital contraception  
    oral contraception  
        factor V Leiden mutation  
        relative risk and actual incidence of  
Venous thrombosis  
Veralipride  
Very-low-density lipoproteins (VLDL)  
Vesalius, Andreas  
Vibratory stimulation  
Virilization  
Vitamin D  
    deficiency with fertility

osteoporosis

PCOS

supplementation trial

Vitamin E

as hot flush treatment

in women with and without PMS

Vitronectin

VLDL (very-low-density lipoproteins)

Voice changes, oral contraception

von Willebrand disease

## W

Wake-Forest timing hypothesis

Weight. See also Obesity

activities and caloric intake

best diet

body mass index (the Quetelet index)

nomogram for

breast cancer risk, effect on

change and levonorgestrel implants

drugs for weight loss

ideal

metabolic syndrome

oral contraception and weight increase

physical exercise

waist/hip ratio

weight loss, difficult to maintain

WELL-HART (Women's Estrogen-progestin Lipid-Lowering Hormone Atherosclerosis Regression Trial)

WEST trial

Western blotting

Whole ovary cryopreservation

Wolffian system

Women's Health Initiative (WHI)

breast cancer and

evidence from

evidence from clinical trials, postmenopausal hormone therapy

stroke

Women's Health, Osteoporosis, Progestin, Estrogen (HOPE) trial

World Health Organization

general descriptions of ovulatory disorders

World Health Organization fracture risk assessment tool, FRAX

## X

45,X (Turner syndrome and variants)

clinical features

clinical management

diagnosis

X and Y chromosome deletions

X-linked disease

46,XX disorders of sexual development

congenital adrenal hyperplasia

adults

11 $\beta$ -hydroxylase (P450c11) deficiency

3 $\beta$ -hydroxysteroid dehydrogenase deficiency

children

21-hydroxylase (P450c21) deficiency

neonatal treatment

pregnancy

preimplantation genetic diagnosis

fetoplacental origin

aromatase (P450arom) deficiency

P450 oxidoreductase deficiency

genital development

cloacal exstrophy

Mayer-Rokitansky-Küster-Hauser syndrome

MURCS association

gestational hyperandrogenism

drug ingestion

pregnancy luteomas

theca-lutein cysts

gonadal (ovarian) development

gonadal dysgenesis

prenatal maternal treatment

sex reversal

true hermaphroditism

46,XX Gonadal Dysgenesis

45,XX/46,XY (chimerism)

45,X/46,XY (mixed gonadal dysgenesis)

47,XXY (Klinefelter syndrome and variants)

46,XY disorders of sexual development

androgen insensitivity syndrome

complete

incomplete

androgen synthesis disorders

17 $\alpha$ -hydroxylase deficiency

3 $\beta$ -hydroxysteroid dehydrogenase deficiency

17 $\beta$ -hydroxysteroid dehydrogenase deficiency

P450 oxidoreductase deficiency

steroid acute regulatory (StAR) protein deficiency

antimüllerian hormone

gonadal (testicular) development

partial gonadal dysgenesis

Swyer syndrome

testicular regression syndrome

LH receptor defects

46,XY Gonadal Dysgenesis

## Y

Y chromosome deletions

Y chromosome microdeletion

Yasmin

Young syndrome

## Z

ZIFT (zygote intrafallopian transfer)

Zinc fingers

Zoledronic acid

Zona pellucida

Zona reaction

ZP3, primary ligand for sperm



Zuclomiphene

Zygotene